

MAIN POWER POLES

TS OPERATOR CIRCUIT

EMERGENCY

NORMAL

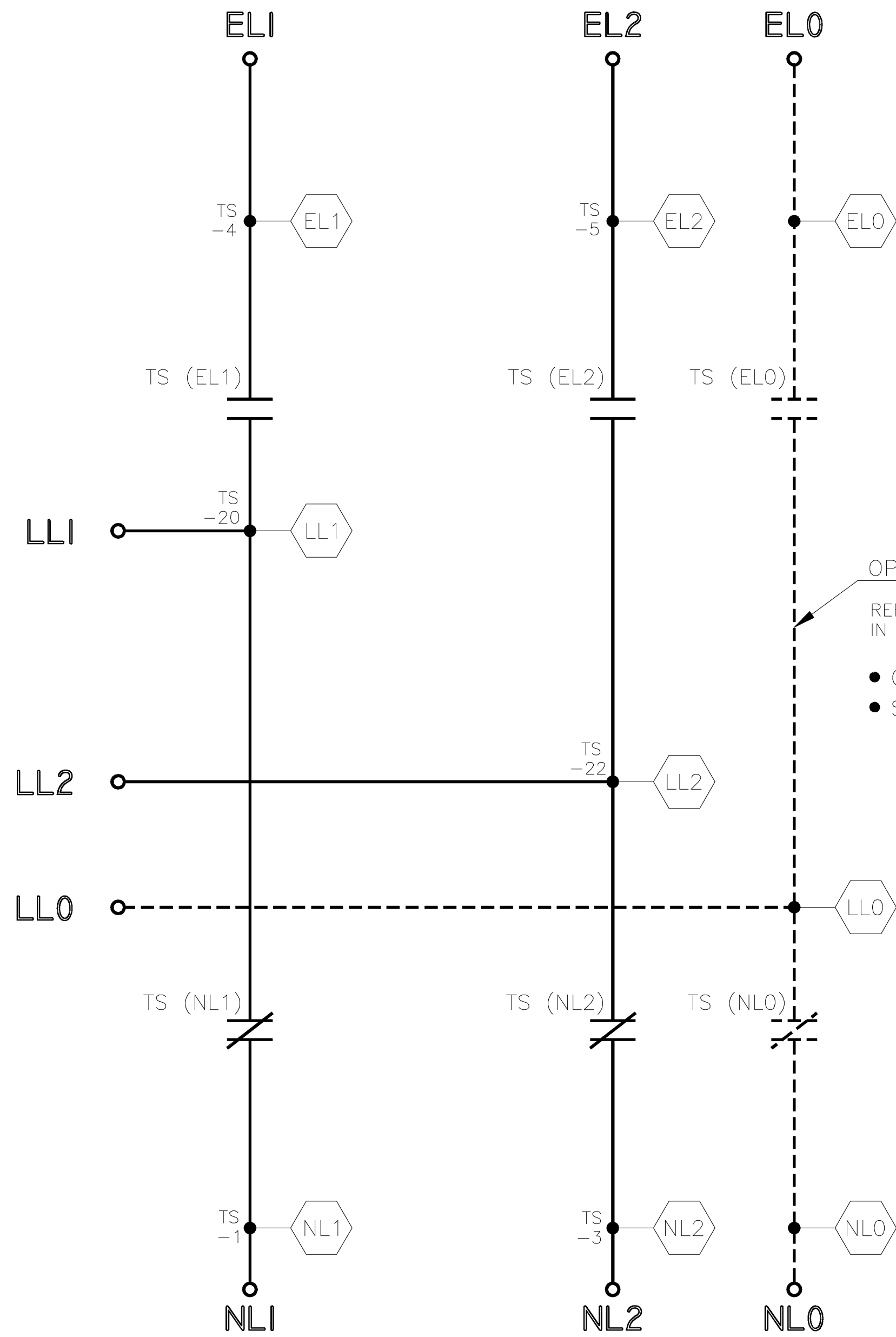

OPTIONAL NEUTRAL TYPES
REFER TO "EXPLANATION OF CATALOG NUMBER CODES"
IN CATALOG NUMBER CHART ON SHEET 1.

- OVERLAPPING CONTACTS
- SOLID BUS PLATE

NORMAL

NOTE:
ATS SHOWN CLOSED ON NORMAL SOURCE.

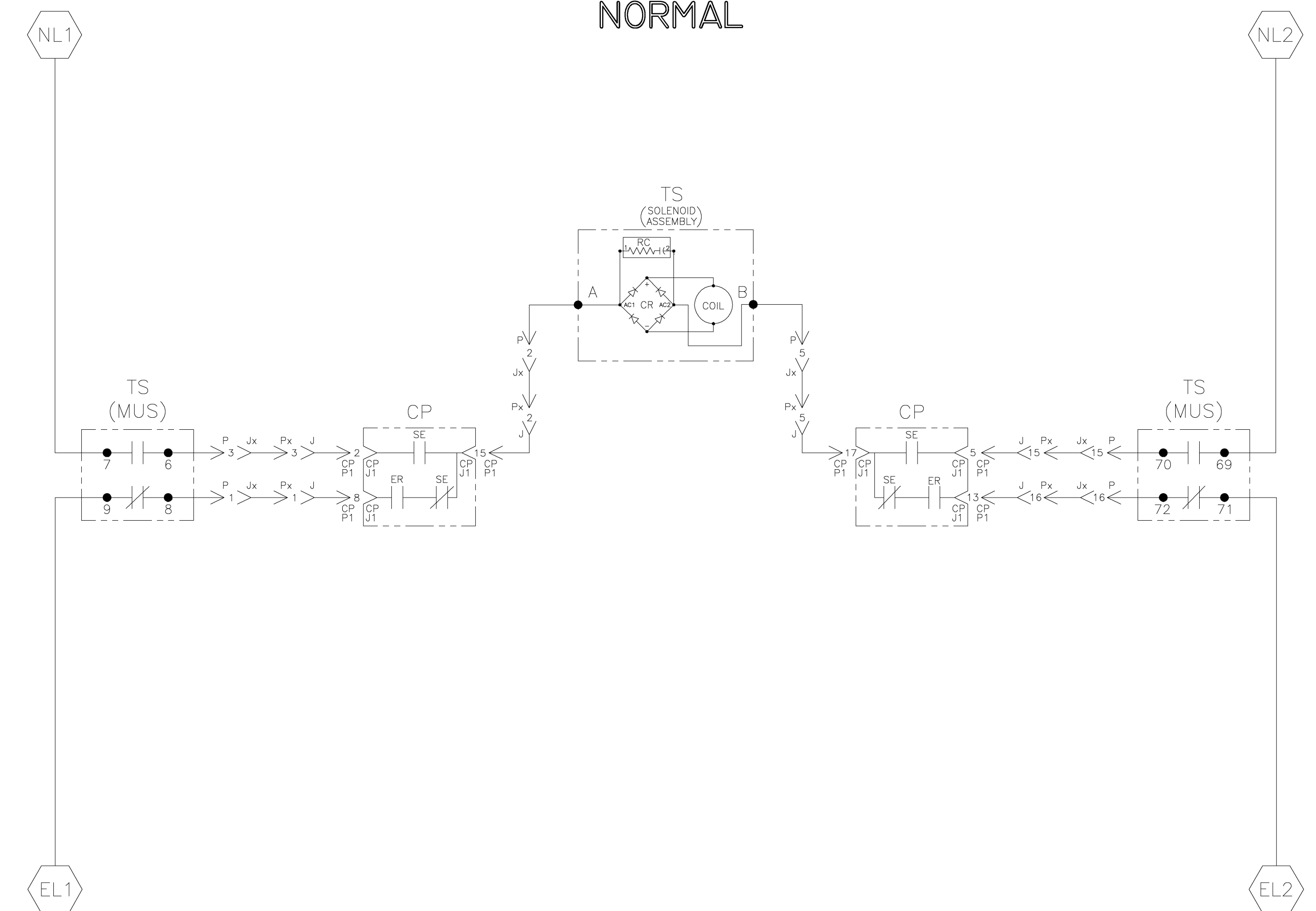

EMERGENCY

TS	SOLENOID POSITION			
	CLOSED BEFORE NORMAL	BEFORE TDC	TDC	BEFORE CLOSED EMERG
6-7				
69-70				
8-9				
71-72				

TDC (TOP DEAD CENTER)
TRANSFER SWITCH TEST & ADJUSTMENT PROCEDURE
SPECIFIES CONTROL CUT-OFF (CONTACT OPENING)
SETTING.

PROJECT NAME:		201114 MM BK 07/22/04				
WIRING DIAGRAM		ISSUE				
SERIES 300 ATS GROUP 1 CONTROLS		SUBSIDIARY DISTRIBUTION				
THIRD ANGLE PROJECTION		<input type="checkbox"/> AN <input type="checkbox"/> AM <input type="checkbox"/> AJ <input type="checkbox"/> AL <input type="checkbox"/> AR <input type="checkbox"/> AS <input type="checkbox"/> AT <input type="checkbox"/> AU <input type="checkbox"/> AV <input type="checkbox"/> AW <input type="checkbox"/> AX <input type="checkbox"/> AY <input type="checkbox"/> AZ <input type="checkbox"/> BA <input type="checkbox"/> BB <input type="checkbox"/> BC <input type="checkbox"/> BD <input type="checkbox"/> BE <input type="checkbox"/> BF <input type="checkbox"/> BG <input type="checkbox"/> BH <input type="checkbox"/> BI <input type="checkbox"/> BJ <input type="checkbox"/> BK <input type="checkbox"/> BL <input type="checkbox"/> BM <input type="checkbox"/> BN <input type="checkbox"/> BO <input type="checkbox"/> BP <input type="checkbox"/> BQ <input type="checkbox"/> BR <input type="checkbox"/> BS <input type="checkbox"/> BT <input type="checkbox"/> BU <input type="checkbox"/> BV <input type="checkbox"/> BW <input type="checkbox"/> BX <input type="checkbox"/> BY <input type="checkbox"/> BZ <input type="checkbox"/> CA <input type="checkbox"/> CB <input type="checkbox"/> CC <input type="checkbox"/> CD <input type="checkbox"/> CE <input type="checkbox"/> CF <input type="checkbox"/> CG <input type="checkbox"/> CH <input type="checkbox"/> CI <input type="checkbox"/> CJ <input type="checkbox"/> CK <input type="checkbox"/> CL <input type="checkbox"/> CM <input type="checkbox"/> CN <input type="checkbox"/> CO <input type="checkbox"/> CP <input type="checkbox"/> CQ <input type="checkbox"/> CR <input type="checkbox"/> CS <input type="checkbox"/> CT <input type="checkbox"/> CU <input type="checkbox"/> CV <input type="checkbox"/> CW <input type="checkbox"/> CX <input type="checkbox"/> CY <input type="checkbox"/> CZ <input type="checkbox"/> DA <input type="checkbox"/> DB <input type="checkbox"/> DC <input type="checkbox"/> DD <input type="checkbox"/> DE <input type="checkbox"/> DF <input type="checkbox"/> DG <input type="checkbox"/> DH <input type="checkbox"/> DI <input type="checkbox"/> DJ <input type="checkbox"/> DK <input type="checkbox"/> DL <input type="checkbox"/> DM <input type="checkbox"/> DN <input type="checkbox"/> DO <input type="checkbox"/> DP <input type="checkbox"/> DQ <input type="checkbox"/> DR <input type="checkbox"/> DS <input type="checkbox"/> DT <input type="checkbox"/> DU <input type="checkbox"/> DV <input type="checkbox"/> DW <input type="checkbox"/> DX <input type="checkbox"/> DY <input type="checkbox"/> DZ <input type="checkbox"/> EA <input type="checkbox"/> EB <input type="checkbox"/> EC <input type="checkbox"/> ED <input type="checkbox"/> EE <input type="checkbox"/> EF <input type="checkbox"/> EG <input type="checkbox"/> EH <input type="checkbox"/> EI <input type="checkbox"/> EJ <input type="checkbox"/> EK <input type="checkbox"/> EL <input type="checkbox"/> EM <input type="checkbox"/> EN <input type="checkbox"/> EO <input type="checkbox"/> EP <input type="checkbox"/> EQ <input type="checkbox"/> ER <input type="checkbox"/> ES <input type="checkbox"/> ET <input type="checkbox"/> EU <input type="checkbox"/> EV <input type="checkbox"/> EW <input type="checkbox"/> EX <input type="checkbox"/> EY <input type="checkbox"/> EZ <input type="checkbox"/> FA <input type="checkbox"/> FB <input type="checkbox"/> FC <input type="checkbox"/> FD <input type="checkbox"/> FE <input type="checkbox"/> FF <input type="checkbox"/> FG <input type="checkbox"/> FH <input type="checkbox"/> FI <input type="checkbox"/> FJ <input type="checkbox"/> FK <input type="checkbox"/> FL <input type="checkbox"/> FM <input type="checkbox"/> FN <input type="checkbox"/> FO <input type="checkbox"/> FP <input type="checkbox"/> FQ <input type="checkbox"/> FR <input type="checkbox"/> FS <input type="checkbox"/> FT <input type="checkbox"/> FU <input type="checkbox"/> FV <input type="checkbox"/> FW <input type="checkbox"/> FX <input type="checkbox"/> FY <input type="checkbox"/> FZ <input type="checkbox"/> GA <input type="checkbox"/> GB <input type="checkbox"/> GC <input type="checkbox"/> GD <input type="checkbox"/> GE <input type="checkbox"/> GF <input type="checkbox"/> GG <input type="checkbox"/> GH <input type="checkbox"/> GI <input type="checkbox"/> GJ <input type="checkbox"/> GK <input type="checkbox"/> GL <input type="checkbox"/> GM <input type="checkbox"/> GN <input type="checkbox"/> GO <input type="checkbox"/> GP <input type="checkbox"/> GQ <input type="checkbox"/> GR <input type="checkbox"/> GS <input type="checkbox"/> GT <input type="checkbox"/> GU <input type="checkbox"/> GV <input type="checkbox"/> GW <input type="checkbox"/> GX <input type="checkbox"/> GY <input type="checkbox"/> GZ <input type="checkbox"/> HA <input type="checkbox"/> HB <input type="checkbox"/> HC <input type="checkbox"/> HD <input type="checkbox"/> HE <input type="checkbox"/> HF <input type="checkbox"/> HG <input type="checkbox"/> HH <input type="checkbox"/> HI <input type="checkbox"/> HJ <input type="checkbox"/> HK <input type="checkbox"/> HL <input type="checkbox"/> HM <input type="checkbox"/> HN <input type="checkbox"/> HO <input type="checkbox"/> HP <input type="checkbox"/> HQ <input type="checkbox"/> HR <input type="checkbox"/> HS <input type="checkbox"/> HT <input type="checkbox"/> HU <input type="checkbox"/> HV <input type="checkbox"/> HW <input type="checkbox"/> HX <input type="checkbox"/> HY <input type="checkbox"/> HZ <input type="checkbox"/> IA <input type="checkbox"/> IB <input type="checkbox"/> IC <input type="checkbox"/> ID <input type="checkbox"/> IE <input type="checkbox"/> IF <input type="checkbox"/> IG <input type="checkbox"/> IH <input type="checkbox"/> II <input type="checkbox"/> IJ <input type="checkbox"/> IK <input type="checkbox"/> IL <input type="checkbox"/> IM <input type="checkbox"/> IN <input type="checkbox"/> IO <input type="checkbox"/> IP <input type="checkbox"/> IQ <input type="checkbox"/> IR <input type="checkbox"/> IS <input type="checkbox"/> IT <input type="checkbox"/> IU <input type="checkbox"/> IV <input type="checkbox"/> IW <input type="checkbox"/> IX <input type="checkbox"/> IY <input type="checkbox"/> IZ <input type="checkbox"/> JA <input type="checkbox"/> JB <input type="checkbox"/> JC <input type="checkbox"/> JD <input type="checkbox"/> JE <input type="checkbox"/> JF <input type="checkbox"/> JG <input type="checkbox"/> JH <input type="checkbox"/> JI <input type="checkbox"/> JJ <input type="checkbox"/> JK <input type="checkbox"/> JL <input type="checkbox"/> JM <input type="checkbox"/> JN <input type="checkbox"/> JO <input type="checkbox"/> JP <input type="checkbox"/> JQ <input type="checkbox"/> JR <input type="checkbox"/> JS <input type="checkbox"/> JT <input type="checkbox"/> JU <input type="checkbox"/> JV <input type="checkbox"/> JW <input type="checkbox"/> JX <input type="checkbox"/> JY <input type="checkbox"/> JZ <input type="checkbox"/> KA <input type="checkbox"/> KB <input type="checkbox"/> KC <input type="checkbox"/> KD <input type="checkbox"/> KE <input type="checkbox"/> KF <input type="checkbox"/> KG <input type="checkbox"/> KH <input type="checkbox"/> KI <input type="checkbox"/> KJ <input type="checkbox"/> KK <input type="checkbox"/> KL <input type="checkbox"/> KM <input type="checkbox"/> KN <input type="checkbox"/> KO <input type="checkbox"/> KP <input type="checkbox"/> KQ <input type="checkbox"/> KR <input type="checkbox"/> KS <input type="checkbox"/> KT <input type="checkbox"/> KU <input type="checkbox"/> KV <input type="checkbox"/> KW <input type="checkbox"/> KX <input type="checkbox"/> KY <input type="checkbox"/> KZ <input type="checkbox"/> LA <input type="checkbox"/> LB <input type="checkbox"/> LC <input type="checkbox"/> LD <input type="checkbox"/> LE <input type="checkbox"/> LF <input type="checkbox"/> LG <input type="checkbox"/> LH <input type="checkbox"/> LI <input type="checkbox"/> LJ <input type="checkbox"/> LK <input type="checkbox"/> LL <input type="checkbox"/> LM <input type="checkbox"/> LN <input type="checkbox"/> LO <input type="checkbox"/> LP <input type="checkbox"/> LQ <input type="checkbox"/> LR <input type="checkbox"/> LS <input type="checkbox"/> LT <input type="checkbox"/> LU <input type="checkbox"/> LV <input type="checkbox"/> LW <input type="checkbox"/> LX <input type="checkbox"/> LY <input type="checkbox"/> LZ <input type="checkbox"/> MA <input type="checkbox"/> MB <input type="checkbox"/> MC <input type="checkbox"/> MD <input type="checkbox"/> ME <input type="checkbox"/> MF <input type="checkbox"/> MG <input type="checkbox"/> MH <input type="checkbox"/> MI <input type="checkbox"/> MJ <input type="checkbox"/> MK <input type="checkbox"/> ML <input type="checkbox"/> MN <input type="checkbox"/> MO <input type="checkbox"/> MP <input type="checkbox"/> MQ <input type="checkbox"/> MR <input type="checkbox"/> MS <input type="checkbox"/> MT <input type="checkbox"/> MU <input type="checkbox"/> MV <input type="checkbox"/> MW <input type="checkbox"/> MX <input type="checkbox"/> MY <input type="checkbox"/> MZ <input type="checkbox"/> NA <input type="checkbox"/> NB <input type="checkbox"/> NC <input type="checkbox"/> ND <input type="checkbox"/> NE <input type="checkbox"/> NF <input type="checkbox"/> NG <input type="checkbox"/> NH <input type="checkbox"/> NI <input type="checkbox"/> NJ <input type="checkbox"/> NK <input type="checkbox"/> NL <input type="checkbox"/> NM <input type="checkbox"/> NO <input type="checkbox"/> NP <input type="checkbox"/> NQ <input type="checkbox"/> NR <input type="checkbox"/> NS <input type="checkbox"/> NT <input type="checkbox"/> NU <input type="checkbox"/> NV <input type="checkbox"/> NW <input type="checkbox"/> NX <input type="checkbox"/> NY <input type="checkbox"/> NZ <input type="checkbox"/> OA <input type="checkbox"/> OB <input type="checkbox"/> OC <input type="checkbox"/> OD <input type="checkbox"/> OE <input type="checkbox"/> OF <input type="checkbox"/> OG <input type="checkbox"/> OH <input type="checkbox"/> OI <input type="checkbox"/> OJ <input type="checkbox"/> OK <input type="checkbox"/> OL <input type="checkbox"/> OM <input type="checkbox"/> ON <input type="checkbox"/> OO <input type="checkbox"/> OP <input type="checkbox"/> OQ <input type="checkbox"/> OR <input type="checkbox"/> OS <input type="checkbox"/> OT <input type="checkbox"/> OU <input type="checkbox"/> OV <input type="checkbox"/> OW <input type="checkbox"/> OX <input type="checkbox"/> OY <input type="checkbox"/> OZ <input type="checkbox"/> PA <input type="checkbox"/> PB <input type="checkbox"/> PC <input type="checkbox"/> PD <input type="checkbox"/> PE <input type="checkbox"/> PF <input type="checkbox"/> PG <input type="checkbox"/> PH <input type="checkbox"/> PI <input type="checkbox"/> PJ <input type="checkbox"/> PK <input type="checkbox"/> PL <input type="checkbox"/> PM <input type="checkbox"/> PN <input type="checkbox"/> PO <input type="checkbox"/> PP <input type="checkbox"/> PQ <input type="checkbox"/> PR <input type="checkbox"/> PS <input type="checkbox"/> PT <input type="checkbox"/> PU <input type="checkbox"/> PV <input type="checkbox"/> PW <input type="checkbox"/> PX <input type="checkbox"/> PY <input type="checkbox"/> PZ <input type="checkbox"/> QA <input type="checkbox"/> QB <input type="checkbox"/> QC <input type="checkbox"/> QD <input type="checkbox"/> QE <input type="checkbox"/> QF <input type="checkbox"/> QG <input type="checkbox"/> QH <input type="checkbox"/> QI <input type="checkbox"/> QJ <input type="checkbox"/> QK <input type="checkbox"/> QL <input type="checkbox"/> QM <input type="checkbox"/> QN <input type="checkbox"/> QO <input type="checkbox"/> QP <input type="checkbox"/> QQ <input type="checkbox"/> QR <input type="checkbox"/> QS <input type="checkbox"/> QT <input type="checkbox"/> QU <input type="checkbox"/> QV <input type="checkbox"/> QW <input type="checkbox"/> QX <input type="checkbox"/> QY <input type="checkbox"/> QZ <input type="checkbox"/> RA <input type="checkbox"/> RB <input type="checkbox"/> RC <input type="checkbox"/> RD <input type="checkbox"/> RE <input type="checkbox"/> RF <input type="checkbox"/> RG <input type="checkbox"/> RH <input type="checkbox"/> RI <input type="checkbox"/> RJ <input type="checkbox"/> RK <input type="checkbox"/> RL <input type="checkbox"/> RM <input type="checkbox"/> RN <input type="checkbox"/> RO <input type="checkbox"/> RP <input type="checkbox"/> RQ <input type="checkbox"/> RR <input type="checkbox"/> RS <input type="checkbox"/> RT <input type="checkbox"/> RU <input type="checkbox"/> RV <input type="checkbox"/> RW <input type="checkbox"/> RX <input type="checkbox"/> RY <input type="checkbox"/> RZ <input type="checkbox"/> SA <input type="checkbox"/> SB <input type="checkbox"/> SC <input type="checkbox"/> SD <input type="checkbox"/> SE <input type="checkbox"/> SF <input type="checkbox"/> SG <input type="checkbox"/> SH <input type="checkbox"/> SI <input type="checkbox"/> SJ <input type="checkbox"/> SK <input type="checkbox"/> SL <input type="checkbox"/> SM <input type="checkbox"/> SN <input type="checkbox"/> SO <input type="checkbox"/> SP <input type="checkbox"/> SQ <input type="checkbox"/> SR <input type="checkbox"/> SS <input type="checkbox"/> ST <input type="checkbox"/> SU <input type="checkbox"/> SV <input type="checkbox"/> SW <input type="checkbox"/> SX <input type="checkbox"/> SY <input type="checkbox"/> SZ <input type="checkbox"/> TA <input type="checkbox"/> TB <input type="checkbox"/> TC <input type="checkbox"/> TD <input type="checkbox"/> TE <input type="checkbox"/> TF <input type="checkbox"/> TG <input type="checkbox"/> TH <input type="checkbox"/> TI <input type="checkbox"/> TJ <input type="checkbox"/> TK <input type="checkbox"/> TL <input type="checkbox"/> TM <input type="checkbox"/> TN <input type="checkbox"/> TO <input type="checkbox"/> TP <input type="checkbox"/> TQ <input type="checkbox"/> TR <input type="checkbox"/> TS <input type="checkbox"/> TT <input type="checkbox"/> TU <input type="checkbox"/> TV <input type="checkbox"/> TW <input type="checkbox"/> TX <input type="checkbox"/> TY <input type="checkbox"/> TZ <input type="checkbox"/> UA <input type="checkbox"/> UB <input type="checkbox"/> UC <input type="checkbox"/> UD <input type="checkbox"/> UE <input type="checkbox"/> UF <input type="checkbox"/> UG <input type="checkbox"/> UH <input type="checkbox"/> UI <input type="checkbox"/> UJ <input type="checkbox"/> UK <input type="checkbox"/> UL <input type="checkbox"/> UM <input type="checkbox"/> UN <input type="checkbox"/> UO <input type="checkbox"/> UP <input type="checkbox"/> UQ <input type="checkbox"/> UR <input type="checkbox"/> US <input type="checkbox"/> UT <input type="checkbox"/> UY <input type="checkbox"/> UZ <input type="checkbox"/> VA <input type="checkbox"/> VB <input type="checkbox"/> VC <input type="checkbox"/> VD <input type="checkbox"/> VE <input type="checkbox"/> VF <input type="checkbox"/> VG <input type="checkbox"/> VH <input type="checkbox"/> VI <input type="checkbox"/> VJ <input type="checkbox"/> VK <input type="checkbox"/> VL <input type="checkbox"/> VM <input type="checkbox"/> VN <input type="checkbox"/> VO <input type="checkbox"/> VP <input type="checkbox"/> VQ <input type="checkbox"/> VR <input type="checkbox"/> VS <input type="checkbox"/> VT <input type="checkbox"/> VU <input type="checkbox"/> VV <input type="checkbox"/> VW <input type="checkbox"/> VX <input type="checkbox"/> VY <input type="checkbox"/> VZ <input type="checkbox"/> WA <input type="checkbox"/> WB <input type="checkbox"/> WC <input type="checkbox"/> WD <input type="checkbox"/> WE <input type="checkbox"/> WF <input type="checkbox"/> WG <input type="checkbox"/> WH <input type="checkbox"/> WI <input type="checkbox"/> WJ <input type="checkbox"/> WK <input type="checkbox"/> WL <input type="checkbox"/> WM <input type="checkbox"/> WN <input type="checkbox"/> WO <input type="checkbox"/> WP <input type="checkbox"/> WQ <input type="checkbox"/> WR <input type="checkbox"/> WS <input type="checkbox"/> WT <input type="checkbox"/> WU <input type="checkbox"/> WV <input type="checkbox"/> WW <input type="checkbox"/> WX <input type="checkbox"/> WY <input type="checkbox"/> WZ <input type="checkbox"/> XA <input type="checkbox"/> XB <input type="checkbox"/> XC <input type="checkbox"/> XD <input type="checkbox"/> XE <input type="checkbox"/> XF <input type="checkbox"/> XG <input type="checkbox"/> XH <input type="checkbox"/> XI <input type="checkbox"/> XJ <input type="checkbox"/> XK <input type="checkbox"/> XL <input type="checkbox"/> XM <input type="checkbox"/> XN <input type="checkbox"/> XO <input type="checkbox"/> XP <input type="checkbox"/> XQ <input type="checkbox"/> XR <input type="checkbox"/> XS <input type="checkbox"/> XT <input type="checkbox"/> XU <input type="checkbox"/> XV <input type="checkbox"/> XW <input type="checkbox"/> XX <input type="checkbox"/> XY <input type="checkbox"/> XZ <input type="checkbox"/> YA <input type="checkbox"/> YB <input type="checkbox"/> YC <input type="checkbox"/> YD <input type="checkbox"/> YE <input type="checkbox"/> YF <input type="checkbox"/> YG <input type="checkbox"/> YH <input type="checkbox"/> YI <input type="checkbox"/> YJ <input type="checkbox"/> YK <input type="checkbox"/> YL <input type="checkbox"/> YM <input type="checkbox"/> YN <input type="checkbox"/> YO <input type="checkbox"/> YP <input type="checkbox"/> YQ <input type="checkbox"/> YR <input type="checkbox"/> YS <input type="checkbox"/> YT <input type="checkbox"/> YU <input type="checkbox"/> YV <input type="checkbox"/> YW <input type="checkbox"/> YX <input type="checkbox"/> YZ <input type="checkbox"/> ZA <input type="checkbox"/> ZB <input type="checkbox"/> ZC <input type="checkbox"/> ZD <input type="checkbox"/> ZE <input type="checkbox"/> ZF <input type="checkbox"/> ZG <input type="checkbox"/> ZH <input type="checkbox"/> ZI <input type="checkbox"/> ZJ <input type="checkbox"/> ZK <input type="checkbox"/> ZL <input type="checkbox"/> ZM <input type="checkbox"/> ZN <input type="checkbox"/> ZO <input type="checkbox"/> ZP <input type="checkbox"/> ZQ <input type="checkbox"/> ZR <input type="checkbox"/> ZS <input type="checkbox"/> ZT <input type="checkbox"/> ZU <input type="checkbox"/> ZV <input type="checkbox"/> ZW <input type="checkbox"/> ZX <input type="checkbox"/> ZY <input type="checkbox"/> ZZ		SCALE: 1:1	ACAD	FILE
ASCO		ASCO POWER TECHNOLOGIES, L.P. FLORHAM PARK, NEW JERSEY 07932 U.S.A.				
DS762485		SHEET 2 OF 4				

WIRE RUN LISTING

CONTROL SIGNALS & INDICATION

NORMAL SOURCE CIRCUITS

WIRE No.	HARNESS 337012 (P) MAIN TS	CLR	AWG
1	TS-8,P-1		16
2	TS-A,P-2		
3	TS-6,P-3		
4	TS-3,P-4		
5	TS-B,P-5		
6	TS-5,P-6		
7	TS-4,P-7		
8	TB/TS-14,P-8		
9	TB/TS-15,P-9		
10	TS-17,P-10		
11	TS-2,P-11		
12	TS-1,P-12		
13	TS-16,P-13		
14	TS-18,P-14		
15	TS-70,P-15		
16	TS-72,P-16		
17	TS-4,TS-9		
18	TS-7,TS-1		
20	TS-3,TS-69		
21	TS-5,TS-71		
8	TS-14,TB/TS-14		
9	TS-15,TB/TS-15		
24	TB/TS-16,P-17		
25	TS-19,P-18		
26	TS-EN,P-19		
27	TS-20,P-20		
28	TS-21,P-21		
29	TS-22,P-22		
30	TS-LN,P-23		
31	TS-NN,P-24		
DEAD END			
25	TS-19,P-18		
28	TS-21,P-21		
11	TS-2,P-11		
REMOVE WIRES			
ADD WIRES			

WIRE No.	HARNESS 309320-001 (Px,Jx) OPTIONAL 3 FT EXTENSION HARNESS	CLR	AWG
1	Px-1,Jx-1		16
2	Px-2,Jx-2		
3	Px-3,Jx-3		
4	Px-4,Jx-4		
5	Px-5,Jx-5		
6	Px-6,Jx-6		
7	Px-7,Jx-7		
8	Px-8,Jx-8		
9	Px-9,Jx-9		
10	Px-10,Jx-10		
11	Px-11,Jx-11		
12	Px-12,Jx-12		
13	Px-13,Jx-13		
14	Px-14,Jx-14		
15	Px-15,Jx-15		
16	Px-16,Jx-16		
24	Px-17,Jx-17		
25	Px-18,Jx-18		
26	Px-19,Jx-19		
27	Px-20,Jx-20		
28	Px-21,Jx-21		
29	Px-22,Jx-22		
30	Px-23,Jx-23		
31	Px-24,Jx-24		
REMOVE WIRES			
ADD WIRES			

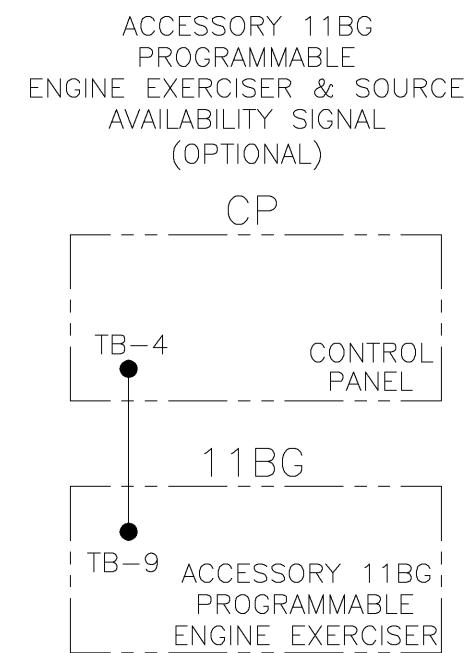

WIRE No.	ACC. 11BG	CLR	AWG
28	CP-TB-4,11BG-TB-9		16

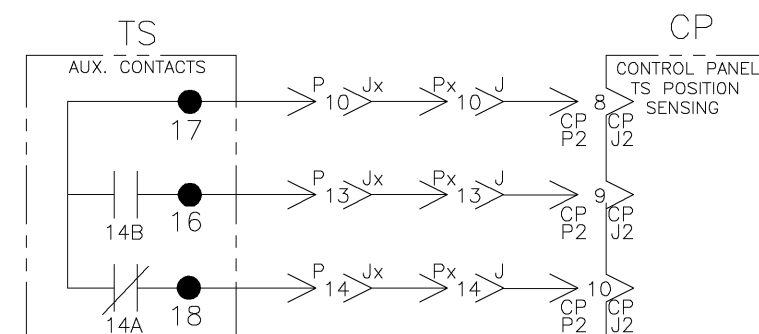

WIRE No.	HARNESS 483763 (J,CP-P1,CP-P2) CONTROL PANEL	CLR	AWG
1	J-1,CP-P1-8		16
2	J-2,CP-P1-15		
3	J-3,CP-P1-2		
4	J-4,CP-P1-4		
5	J-5,CP-P1-17		
6	J-6,CP-P1-12		
7	J-7,CP-P1-7		
8	J-8,CP-P2-2		
9	J-9,CP-P2-3		
10	J-10,CP-P2-8		
11	J-11,CP-P1-10		
12	J-12,CP-P1-1		
13	J-13,CP-P2-9		
14	J-14,CP-P2-10		
15	J-15,CP-P1-5		
16	J-16,CP-P1-13		
24	J-17,CP-P2-1		
25	J-18,CP-P1-14		
REMOVE WIRES			
11	J-11,CP-P1-10		
25	J-18,CP-P1-14		

NORMAL

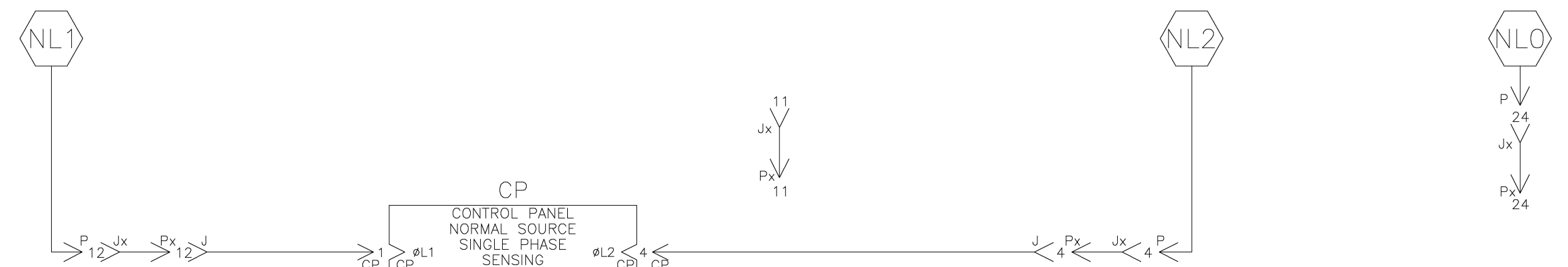

EMERGENCY SOURCE CIRCUITS

EMERGENCY

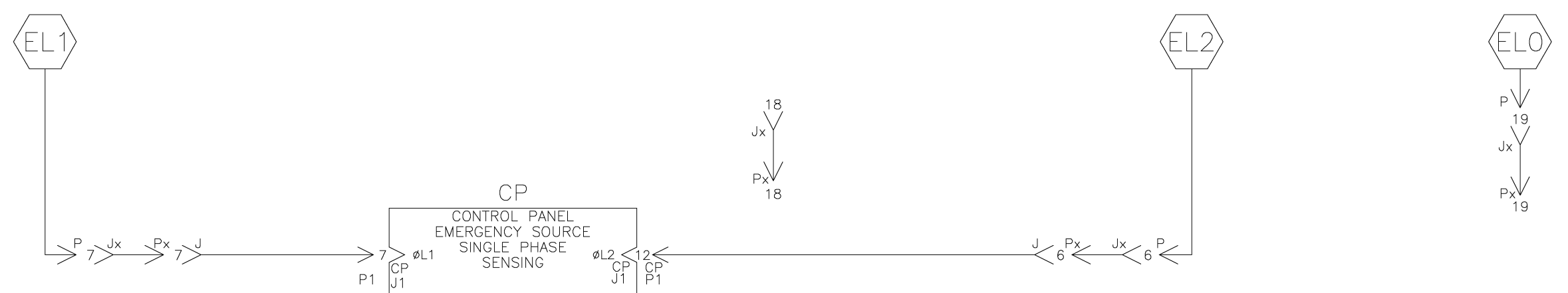

LOAD TERMINAL CIRCUITS

LOAD



PROJECT NAME:		201114 MM BK 07/22/04	
WIRING DIAGRAM		ISSUE	
SERIES 300 ATS		SUBSIDIARY DISTRIBUTION	
GROUP 1 CONTROLS		THIRD ANGLE PROJECTION	
MANUFACTURING TOLERANCES TO BE IN ACCORDANCE WITH ASCO PROCEDURE MP-1-003. FOR PLASTIC PARTS SEE MP-1-055.		ASSEMBLY REF. NO.	
DRAWN BY MM 07/22/04		SCALE 1:1 ACAD FILE	
CHECKED BY BK 07/22/04		SIZE DWG. NO.	
DRAFTING APPROVAL		DS762485	
FINAL APPROVAL		CHANGE LETTER	
ASCO POWER TECHNOLOGIES, L.P. FLOHAM PARK, NEW JERSEY 07932 U.S.A.		ECON NO. 201114 SHEET 3 OF 4	

