

# Operator's Manual

## ASCO® 4000 Series ACTS Automatic Closed-Transition Transfer Switches J-design 150-600A, H-design 800-1200A, G-design 1600-3000A, F-design 4000A

**⚠ DANGER**  
DANGER is used in this manual to warn of high voltages capable of causing shock, burns, or death.

**⚠ WARNING**  
WARNING is used in this manual to warn of possible personal injury.

**⚠ CAUTION**  
CAUTION is used in this manual to warn of possible equipment damage.



Refer to the outline and wiring drawings provided with your 4000 Series ACTS for all installation and connection details and accessories.

Refer to *Group 5 Controller User's Guide* 381333-126 for ATS status display messages, time delays, pickup & dropout settings, and adjustments.

An experienced licensed electrician must install the ACTS.

### Rating Label

Each automatic closed-transition transfer switch contains a rating label to define the loads and fault circuit withstand / closing ratings. Refer to the label on the transfer switch for specific values.

**⚠ WARNING**  
Do not exceed the values on the rating label. Exceeding the rating can cause personal injury or serious equipment damage.

### Nameplate

The Transfer Switch nameplate includes data for each specific 4000 Series ACTS. Use the switch only within the limits shown on this nameplate. A typical Catalog Number is shown on the next page with its elements explained.

TABLE OF CONTENTS	
	section-page
INSTALLATION .....	1-1
Mounting and Line Connections .....	1-1
Auxiliary Circuits and Harness .....	1-2
Engine Starting Contacts .....	1-2
Functional Test .....	1-3 through 1-7
TESTING & SERVICE .....	2-1
Transfer Test .....	2-1
Preventive Maintenance .....	2-1
Disconnecting the Controller .....	2-1
Manual Load Transfer .....	2-2
Trouble-Shooting .....	2-2
INDEX .....	back cover



## Catalog Number Identification

Typical 4000 Series catalog no. for H-design solid neutral, 3 pole, 1200 amp, 480 V, ACTS in Type 1 enclosure:

design prefix letter	H	4ACTS	A	3	1200	N	5	C
	<b>Neutral</b>	<b>Phase Poles</b>	<b>Amperes</b>		<b>Voltage</b>		<b>Controller</b>	<b>Enclosure</b>
	A – solid B – switched blank – none	2 – single Ø 3 – three Ø	150 260 400 600 800 1000	1200 1600 2000 2600 3000 4000	A 115 * B 120 * C 208 D 220 E 230 F 240 G 277 H 380	J 400 K 415 L 440 M 460 N 480 P 550 Q 575 R 600	5 – standard 5X – if accessories ordered	C – type 1 F – type 3R G – type 4 H – type 4X L – type 12 M type 3R secure N type 4 secure Q type 4X secure P type 12 secure blank – open type

\* these voltages are available on 150 through 400 amp. only.

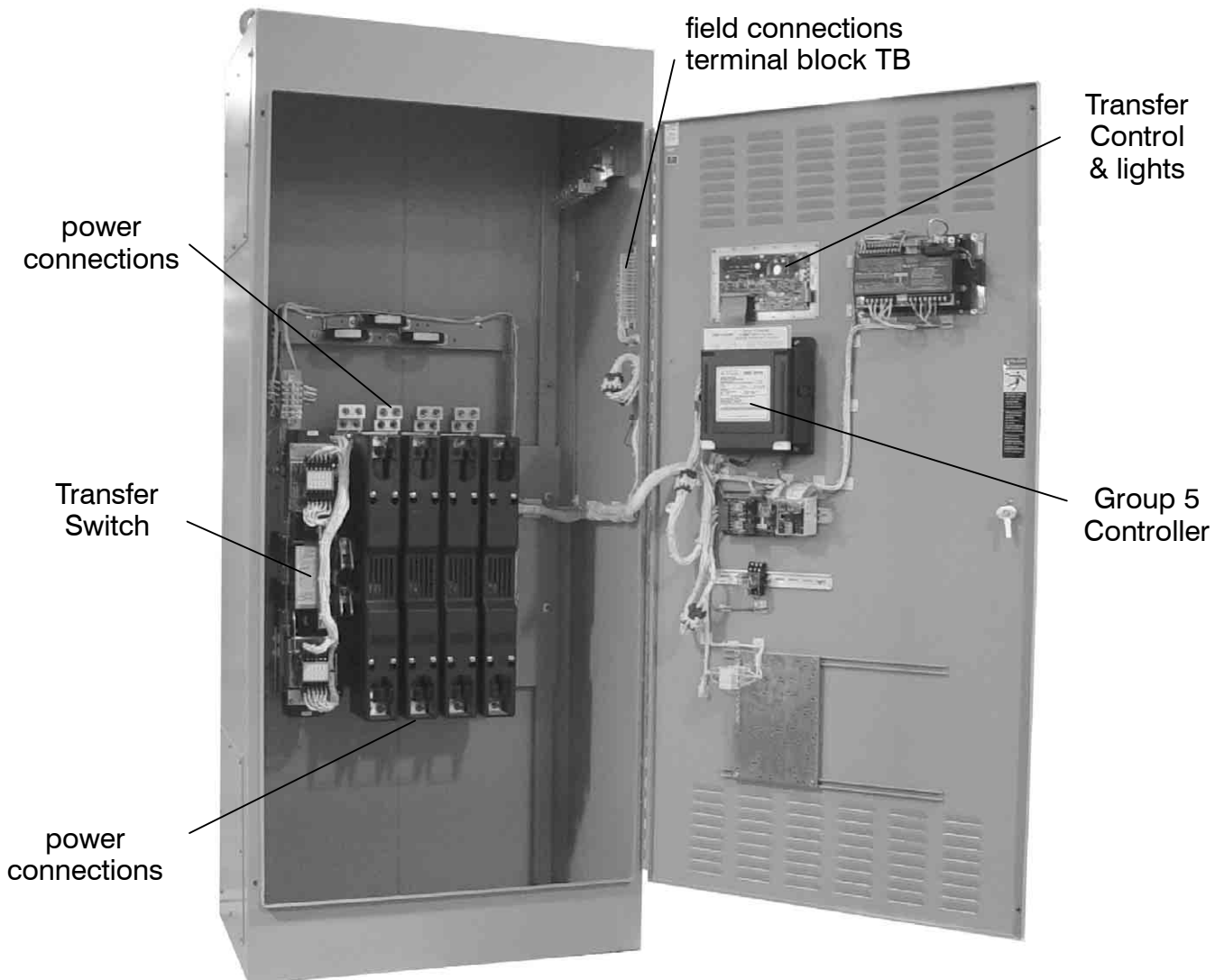

1200 amp. size in typical enclosure with location of customer connections

## SECTION 1 INSTALLATION

ASCO 4000 Series Automatic Closed–Transition Transfer Switches are factory wired and tested. Field installation simply requires mounting and connection of service cables, and auxiliary control circuits (if required).

### Remove the Shipping Skid

For large switches, open the front door and remove the four lag screws (2 in front, 2 in rear) securing enclosure to the wood skid.

### Supporting Foundation

The supporting foundation for the enclosure must level and straight. Refer to the applicable enclosure outline drawing included with the 4ACTS for all mounting details including door opening space.

If bottom cable entry is used, the foundation must be prepared so that the conduit stubs are located correctly. Refer to the enclosure outline drawing for specified area and location. Provide cable bending space and clearance to live metal parts. When a concrete floor is poured, use interlocking conduit spacer caps or a wood or metal template to maintain proper conduit alignment.

### Mounting

Refer to the outline and mounting diagram provided with the ATS; it shows all mounting details and instructions.

#### CAUTION

**Protect the switch from construction grit and metal chips to prevent malfunction or shortened life of the automatic switch switch.**

Mount the ATS vertically to a rigid supporting structure. Level all mounting points by using flat washers behind the holes to avoid distortion of the switch.

The controller is mounted on the cabinet door. An add-on DIN rail is provided for some optional accessories and is mounted below controller on the door.

#### DANGER

**De-energize the conductors before making any line or auxiliary circuitry connections. Be sure that Normal and Emergency line connections are in proper phase rotation. Place engine generator starting control in the OFF position. Make sure engine generator is not in operation.**

### Testing Power Conductors

Do not connect the power conductors to the transfer switch until they are tested. Installing power cables in conduit, cable troughs and ceiling-suspended hangers often requires considerable force. The pulling of cables can damage insulation and stretch or break the conductor's strands. For this reason, after the cables are pulled into position, and before they are connected, they

should be tested to verify that they are not defective or have been damaged during installation.

### Connecting Power Conductors

A *Wiring Diagram* is furnished with the ASCO 4000 Series 4ACTS (separate from this manual). Refer to this drawing. All wiring must be made in accordance with the National Electrical Code and local codes.

After the power cables have been tested, connect them to the appropriate terminal lugs on the transfer switch as shown on the wiring diagram provided with the switch. Make sure the lugs provided are suitable for use with the cables being installed. Standard terminal lugs are solderless screw type and will accept the wire sizes listed on the drawings provided with the switch. Be careful when stripping insulation from the cables; avoid nicking or ringing the conductor. Remove surface oxides from cables by cleaning with a wire brush. When aluminum cable is used, apply joint compound to conductors. Tighten cable lugs to the torque specified on rating label.

Do not run cables in front of or behind the switch. Cables can be bundled on the right side of the switch. Maintain proper electrical clearance between the live metal parts and grounded metal: ½ inch minimum for 150-400 amps, 1 inch minimum over 400 amps.

It is not necessary to remove the barriers from the transfer switches to install the cables. If you do remove them, however, be sure to reinstall the barriers carefully.

### Bus Connections

For large switches use grade 5 hardware to connect bus to appropriate terminal plates. Wipe off the bus surfaces before they are joined. If the bus is very dirty, gently clean the surfaces with a non-flammable solvent. Avoid touching the cleaned surfaces.

Tighten bolted joints to the torque specified in Table A.

#### CAUTION

**The reliability of the connection depends on how clean and how tight the joint is.**

Table A. Tightening torque values for bolted joints (Grade 5 hardware)

Bolt Diameter in inches	Tightening Torque in foot pounds
1/4	7
5/16	12
3/8	20
1/2	50
5/8	95
3/4	155

# INSTALLATION (continued)

## Controller Ground

A grounding wire must be connected to the controller's lower left mounting stud. Because the controller is mounted on the enclosure door, a conductive strap must be used between the enclosure and the door. This connection provides proper grounding which does not rely upon the door hinges.

## Harnesses

The transfer switch is connected to the left side of the control panel by a plug-in harness (two plugs).

## Auxiliary Circuits

Connect auxiliary circuit wires to appropriate terminals on the transfer switch. Note the control features that are furnished on this switch. Make the necessary auxiliary connections by referring to the Wiring Diagram.

## Engine Starting Contacts

The engine control contact connections (if used) are located on the transfer switch. Connect signal wires to appropriate terminals as specified in Table B and shown in Figures 1-1 and 1-2. See the wiring diagram too.

Table B. Engine start connections

When normal source fails	Terminals on transfer switch
contact closes	TB1 and TB2
contact opens	TB1 and TB3

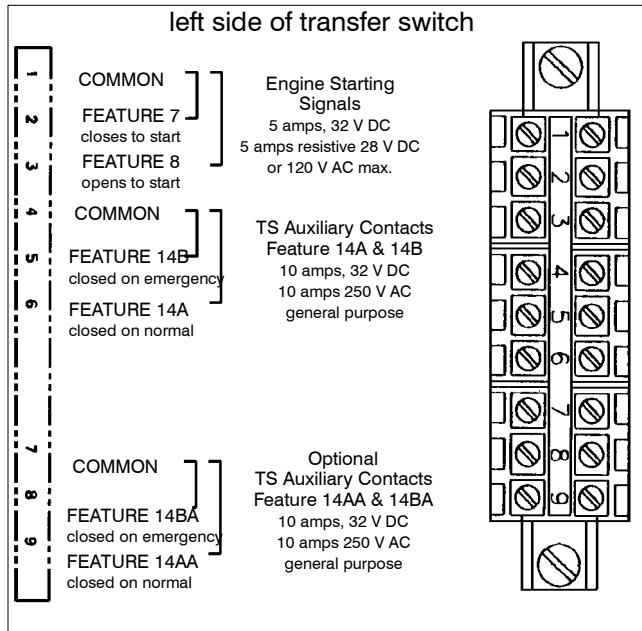

Figure 1-1. Connections to engine starting contact terminal block for 150 through 1200 amp. J & H-design transfer switches.

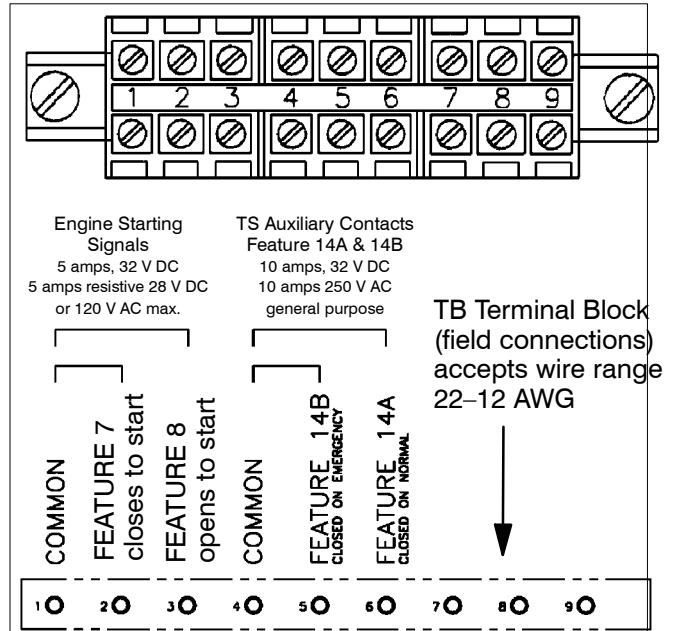

Figure 1-2. Connections to engine starting contact terminal block located on 1600 through 3000 amp. G-design transfer switches.

# INSTALLATION *(continued)*

## Functional Test

The Functional Test consists of three checks:

- 1 — Manual Operation Test, pages 1-3, 1-4, 1-5
- 2 — Voltage Checks, page 1-6
- 3 — Electrical Operation, page 1-7

**⚠ CAUTION**

**Do these checks in the order presented to avoid damaging the ATS.**

Read all instructions on the Wiring Diagram and labels affixed to the ATS. Note the control features that are provided and review their operation before proceeding.

Continue to **1 – Manual Operation Test** starting below.

### 1 – Manual Operation Test

A detachable operator handle is provided on the transfer switch **for maintenance purposes only**. Manual operation of the transfer switch must be checked before it is operated electrically.

**⚠ WARNING**

**Do not manually operate the transfer switch until both power sources are disconnected: open both circuit breakers.**

1. Select the appropriate switch design / amp. size and follow directions for installing and using the handle:

*150–1200 amp J, H–designs* Fig. 1-3, -4, -6 thru -11. Attach the manual handle onto the shaft hub, left side of the operator.

*1600 – 3000 amp. G–design* See Figures 1-5, 1-12. Install the hub (with pin) onto the shaft and insert the manual firmly into the side hole in the hub. Push in or pull out hub to engage opposite source contacts.

*4000 amp. F–design* See Figure 1-13. Insert the manual handle into the hole in the weight.

2. Move the handle as shown to manually operate the Transfer Switch. The switch should operate smoothly without binding. If it does not, check for shipping damage or construction debris. Repeat the manual operation check on the other Transfer Switch.
3. Return the transfer switch to the *N* (closed on normal) position. If removable, remove the maintenance handle and store it on the transfer switch in the place provided.

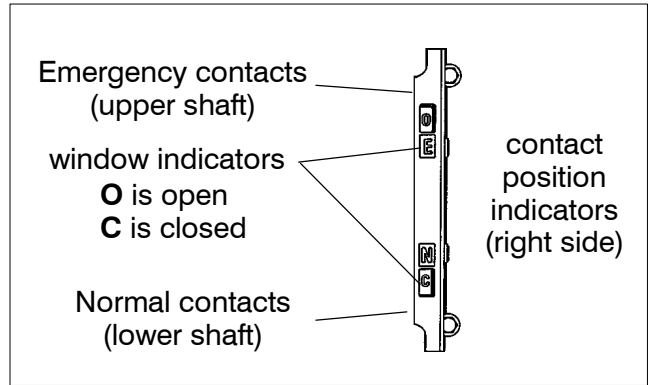

Figure 1-3. Contact position indicators on 150–600 amp. J–design transfer switches . Shown with Emergency open and Normal closed.

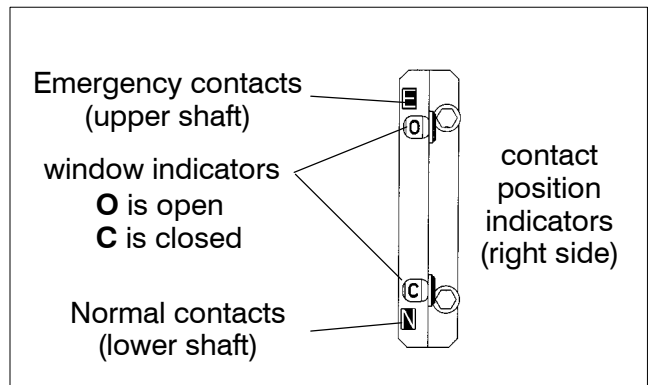

Figure 1-4. Contact position indicators on 800–1200 amp. H–design transfer switches . Shown with Emergency open and Normal closed.

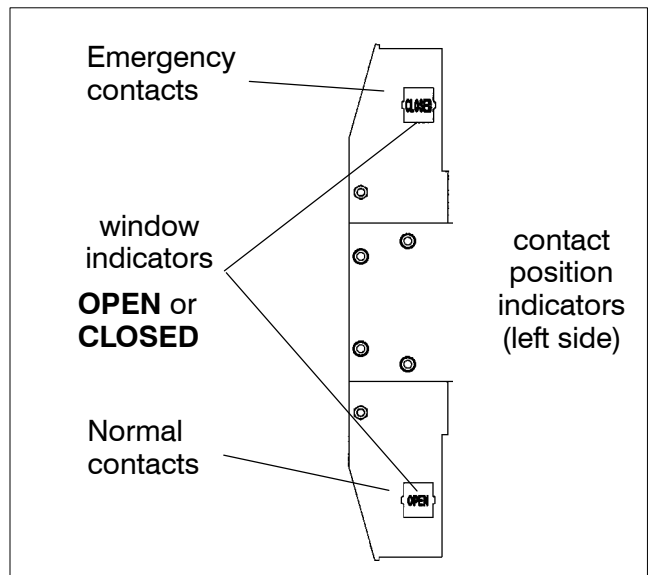

Figure 1-5. Contact position indicators on 1600–3000 amp. G–design transfer switches . Shown with Emergency closed and Normal open.

# INSTALLATION *(continued)*

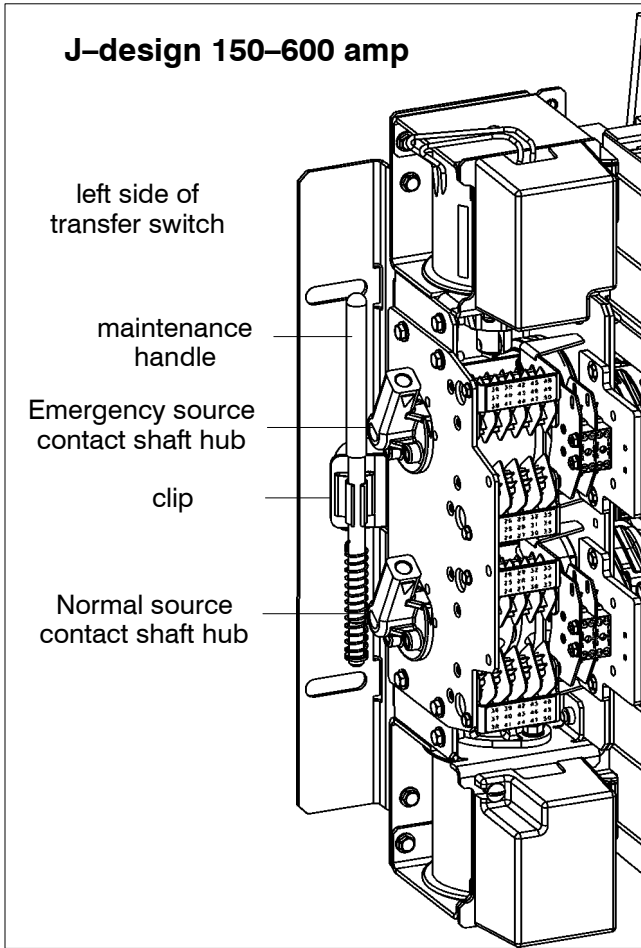

Figure 1-6. Maintenance handle on 150-600 amp. J-design transfer switches. Hubs shown with Normal contacts closed & Emergency open.

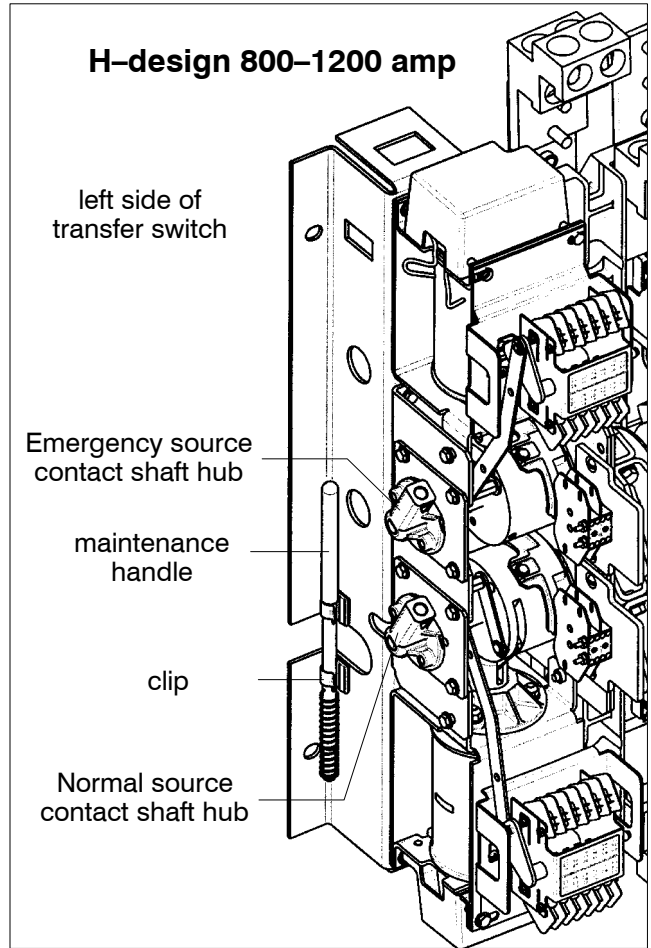

Figure 1-9. Maintenance handle on 800-1200 amp. H-design transfer switches. Hubs shown with Normal contacts closed & Emergency open.

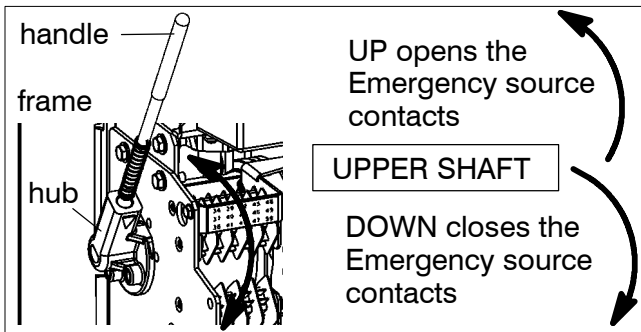

Figure 1-7. Emergency (upper shaft) operation on 150-600 amp. J-design transfer switches.

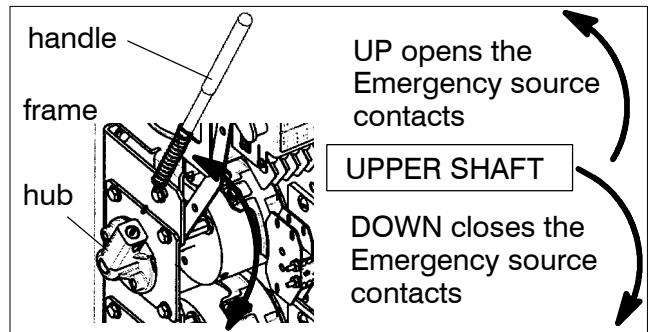

Figure 1-10. Emergency (upper shaft) operation on 800-1200 amp. H-design transfer switches.

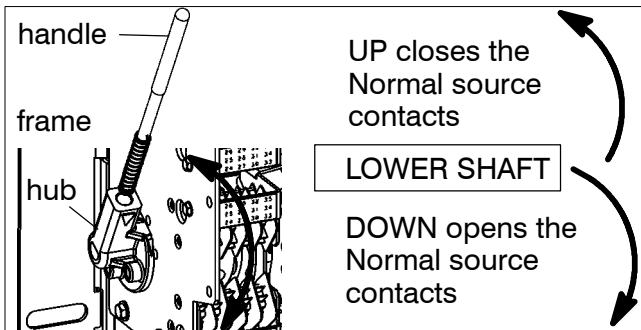

Figure 1-8. Normal (lower shaft) operation on 150-600 amp. J-design transfer switches..

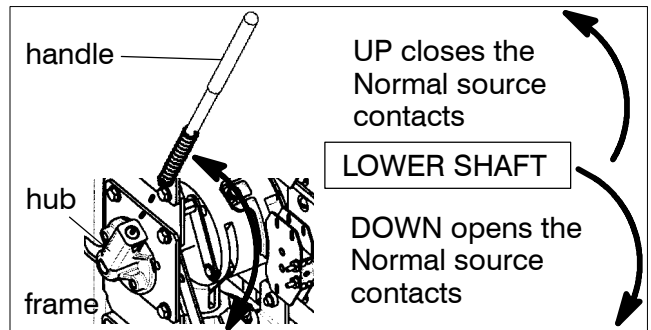

Figure 1-11. Normal (lower shaft) operation on 800-1200 amp. H-design transfer switches..

## INSTALLATION (continued)

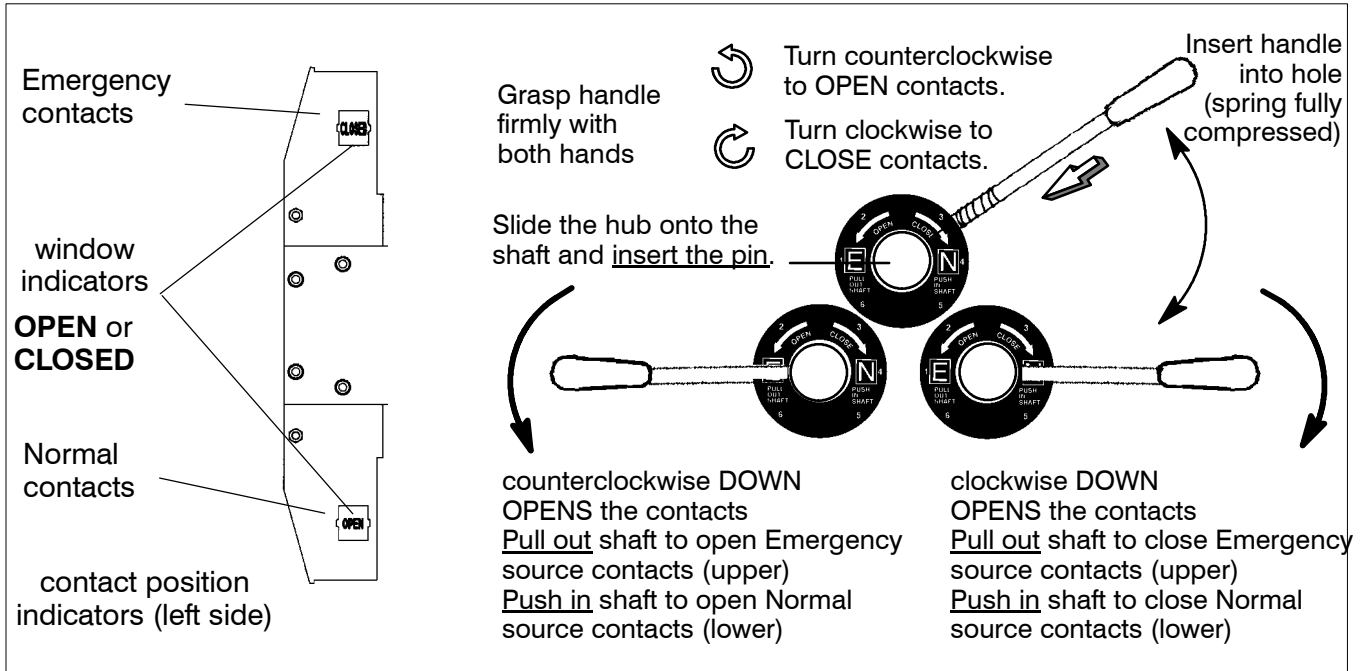

Figure 1-12. Removable maintenance handle and positions on 1600 – 3000 amp. G-design transfer switches.

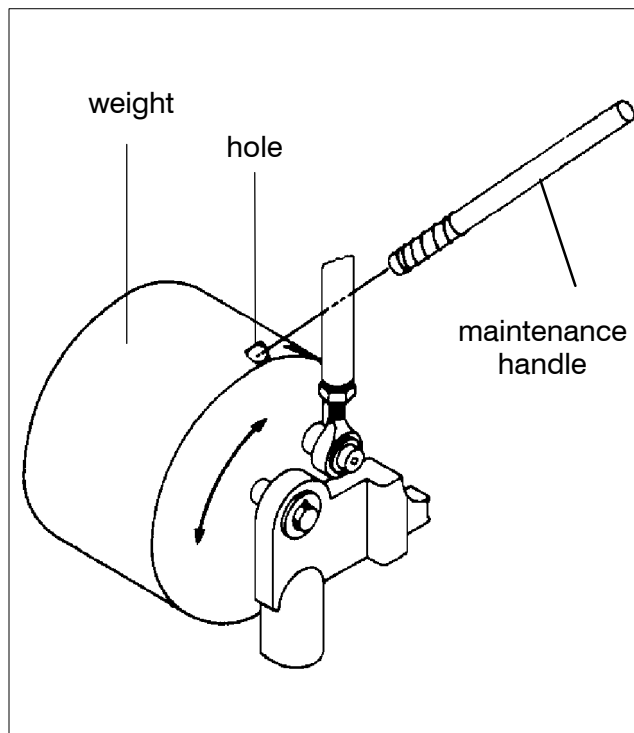

Figure 1-13. Removable maintenance handle on 4000 amp. F-design transfer switch.

### **WARNING**

Verify that the maintenance handle has been removed and stored properly before proceeding!

Now continue to 2 – Voltage Checks on page 1-6.

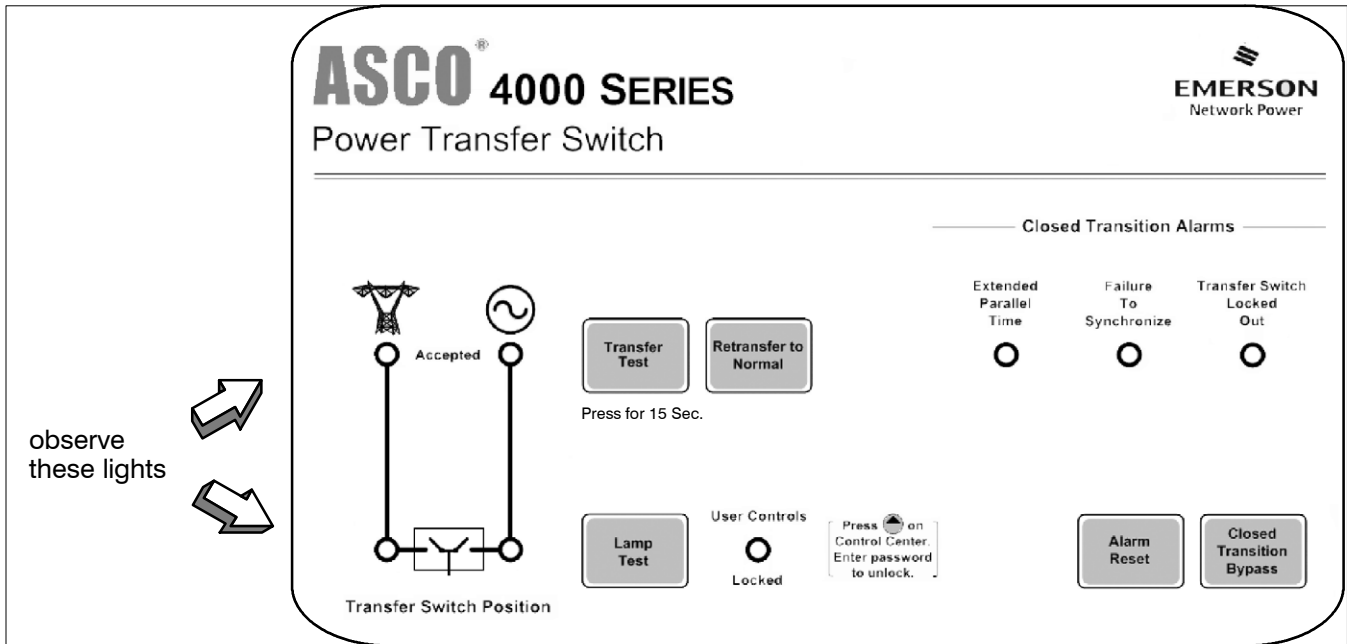

Figure 1-14. Standard controls and indicators.

## 2 – Voltage Checks

First check the nameplate on the transfer switch; the rated voltage must be the same as the normal and emergency line voltages.

**WARNING**  
Verify that the maintenance handle has been removed and stored properly before proceeding!

**CAUTION**  
Verify that the feeders have been connected to the proper terminal lugs.

**DANGER**  
Use extreme caution when using a meter to measure voltages. Do not touch power terminals; shock, burns, or death could result

Perform steps 1 through 6 at the right. Observe the status lights. See Figure 1–14.

- Black circle means light is on.
- White circle means light is off.

\* If necessary, adjust the voltage regulator on the generator according to the manufacturer’s recommendations. The automatic transfer switch will respond only to the rated voltage specified on the transfer switch nameplate.

**Notes:** Refer to Section 3 of the Group 5 Controller *User’s Guide* 381333–126 for how to display the status of the ATS and the voltage and frequency of each source. Press the **Lamp Test** button to verify that all 8 lights work.

Now continue to **3 – Electrical Operation** on next page.

1	Close the normal source (utility) circuit breaker. The two left lights should come on. The normal source <i>Accepted</i> (upper left) and the <i>Transfer Switch Position</i> connected to normal (lower left) lights should be on.	
2	Carefully use an accurate voltmeter to check the phase to phase and phase to neutral voltages present at the transfer switch normal source terminals.	
3	Close the emergency source (generator) circuit breaker. (Start generator, if necessary.) Another light should come on. The emergency source <i>Accepted</i> light (upper right) should be on.	
4	Carefully use an accurate voltmeter to check the phase to phase and phase to neutral voltages present at the transfer switch emergency source terminals.*	
5	Carefully use a phase rotation meter to check the phase rotation of the emergency source; it must be the <u>same</u> as the phase rotation of the normal source (refer to wiring diagram).	
6	Shut down the generator, if applicable. The emergency source <i>Accepted</i> light (upper right) should go off. Then set the generator’s starting control switch to <i>automatic</i> . Remove all meters; close enclosure door.	

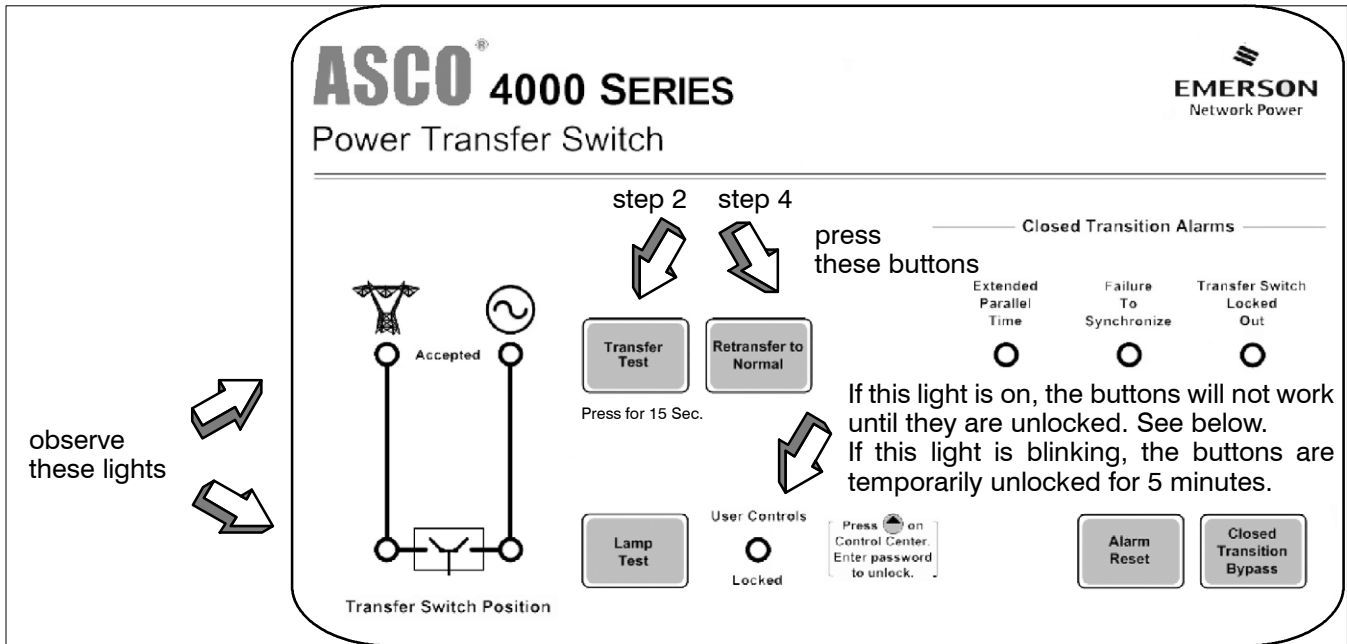

Figure 1-15. User controls and indicators.

### 3 – Electrical Operation

This procedure will check the electrical operation of the automatic closed-transition transfer switch.

**⚠ WARNING**

**Close the enclosure door first.**

#### Transfer Test

Both normal and emergency sources must be available and the emergency source generator (if used) must be capable of being started in this procedure.

Perform steps 1 through 5 at the right. Observe the status lights. See Figure 1-15.

- Black circle means light is on.
- White circle means light is off.

If the *User Controls Locked* light is on, the buttons (user controls) will not work until you unlock them.

**How to temporarily unlock the user controls (if the User Controls Locked light is on)**

Press up or down arrow keys on *Transfer Control Center* (Group 5 Controller), enter the password, and press *Enter* key. The user controls are now unlocked for 5 minutes. During that time the light will blink.

To permanently unlock or lock the user controls refer to *Group 5 Controller User's Guide 381333-126*. Password information and time delay settings are provided there.

**\*\* Note:** If you do not want closed-transition transfer, press the **Closed Transition Bypass** button while the Power Control Center (controller display) shows *Waiting for In-Sync*. This action causes open-transition (momentary load interruption) transfer to the opposite source, if conditions permit.

1	The two left lights should be on; the normal source <i>Accepted</i> (upper left) and the <i>Transfer Switch Position</i> connected to normal (lower left) should be on.	<p style="text-align: center;">Transfer Switch Position</p>
2	Press and <u>hold</u> the <b>Transfer Test</b> button until the generator starts and runs (this should happen within 15 sec.). The emergency source <i>Accepted</i> light (upper right) should come on.	<p style="text-align: center;">Transfer Switch Position</p>
3	Transfer switch should operate to emergency (closed-transition overlap). The <i>Transfer Switch Position</i> connected to emergency light (lower right) should come on and the connected to normal light (lower left) should be off (you might see and hear the brief overlap transfer). If Feature 2B is used, transfer to emergency occurs after the time delay. **	<p style="text-align: center;">Transfer Switch Position</p>
4	The transfer switch should operate back to normal after Feature 3A time delay. For immediate retransfer press the <b>Retransfer to Normal</b> button. The <i>Transfer Switch Position</i> connected to normal light (lower left) should come on and the connected to emergency (lower right) light should be off.	<p style="text-align: center;">Transfer Switch Position</p>
5	The generator will stop after Feature 2E time delay (unloaded running engine cooldown). The emergency source <i>Accepted</i> light (upper right) should go off. This completes the functional test of the ACTS.	<p style="text-align: center;">Transfer Switch Position</p>

## SECTION 2 TESTING & SERVICE

### TRANSFER TEST

Operate the 4000 Series ACTS at least once a month by following the five-step **Electrical Operation Transfer Test** procedure on page 1–6.

### PREVENTIVE MAINTENANCE

Reasonable care in preventive maintenance will insure high reliability and long life for the 4000 Series ACTS. An annual preventive maintenance program is recommended.

In the United States, ASCO Services, Inc. (ASI) is ASCO Power Technologies's national service organization. ASI can be contacted at 1-800-800-2726 (ASCO) for information on preventive maintenance agreements.

In Canada, for service call 1-888-234-2726 (ASCO).

### Checklist for Yearly Inspection

#### **DANGER**

**Hazardous voltage capable of causing shock, burns, or death is used in this switch. Deenergize both Normal – Emergency power sources before performing inspections!**

- Clean the ACTS enclosure.** Brush and vacuum away any excessive dust accumulation. Remove any moisture with a clean cloth.
- Check the transfer switch contacts.** Remove the transfer switch barriers and check contact condition. Replace the contacts if they become pitted or worn excessively. Reinstall the barriers carefully.
- Maintain transfer switch lubrication.** If the transfer switch is subjected to severe dust or abnormal operating conditions, renew factory lubrication on all movements and linkages. Relubricate the solenoid operator if the TS coil is replaced. Do not use oil; order **lubrication 625550-001** (Castrol *Endurex*<sup>®</sup> 4000 lubricant) for 150–400 amp., or order **lubrication kit 75-100** for 600–4000 amp. sizes.
- Check all cable connections & retighten them.**

### REPLACEMENT PARTS

Replacement parts are available in kit form. When ordering parts provide the Serial No., Bill of Material No. (BOM), and Catalog No. from the transfer switch nameplate. Contact your local ASCO Power Technologies Sales Office or ASI:

in United States call 1 800 – 800 – ASCO (2726)  
or in Canada call 1 888 – 234 – ASCO (2726)

### DISCONNECTING THE CONTROLLER

The harness disconnect plugs are furnished for repair purposes only and should not have to be unplugged. If the controller must be isolated, follow these steps:

#### Disconnecting the Plugs

#### **WARNING**

**Do not unplug the controller until steps 1a or 1b is completed.**

1. Observe the position of the transfer switch.
  - a. If the transfer switch is in the *Normal* position, first place standby engine starting control in the *off* position. Second, then open the emergency source circuit breaker. Third, open the normal source circuit breaker.
  - b. If the transfer switch is in the *Emergency* position, first open the normal source circuit breaker. Second, place the engine starting control in the *test* or *run* position. Third, open the emergency source circuit breaker.
2. Separate the two quick disconnect plugs by squeezing the latches. Do not pull on the harness wires.

#### Reconnecting the Plugs

#### **WARNING**

**Do not unplug the controller until steps 1a or 1b is completed.**

1. Observe the position of the transfer switch.
  - a. If the transfer switch is in the *Normal* position, first be sure that both normal and emergency source circuit breakers are open. Second, be sure that the standby engine starting control is still in the *off* position.
  - b. If the transfer switch is in the *Emergency* position, first be sure that both normal and emergency source circuit breakers are open.
2. The two harness plugs and sockets are keyed. Carefully align the plugs with the sockets and press straight in until both latches click. Close the door!
3. Restore the two sources in sequence as follows:
  - a. If the transfer switch is in the *Normal* position, first close the normal source circuit breaker. Second, close the emergency source circuit breaker. Third, place the standby engine starting control in the *automatic* position.
  - b. If the transfer switch is in the *Emergency* position, first close the emergency source circuit breaker. Second close the normal source circuit breaker.

## TESTING & SERVICE (continued)

### MANUAL LOAD TRANSFER

This procedure will manually transfer the load if the controller is disconnected.

**⚠ WARNING**

**Do not manually operate the transfer switch until both power sources are disconnected (all conductors deenergized).**

1. Deenergize both the normal and emergency source conductors (remove fuses or open circuit breakers).

2. Use the maintenance handle to manually operate the transfer switch to the opposite source. First open the closed contacts, then close the other contacts. Do not leave both closed. See *Manual Operation* on page 1-3.
3. Then remove the maintenance handle. See page 1-3.

**⚠ WARNING**

**Verify that the maintenance handle has been removed before proceeding!**

4. If the transfer switch is in the Emergency position manually start the engine generator and then install emergency source fuse or close the circuit breaker.

### TROUBLE-SHOOTING

Note any optional accessories that may be furnished on the ACTS and review their operation. Refer to any separate drawings and/or instructions that may be packed with the ACTS.

**⚠ DANGER**

**Hazardous voltage capable of causing shock, burns, or death is used in this switch. Do not touch the power or load terminals of the transfer switch!**

Table 2-1. Trouble-Shooting Checks.

PROBLEM	CHECK IN NUMERICAL SEQUENCE		
	1 OPERATION	2 GEN-SET	3 VOLTAGE
Engine-generator set does not start when the <b>Transfer Test</b> button is pressed and <u>held</u> or when normal source fails.	Hold <i>Transfer Test</i> button 15 seconds or the outage must be long enough to allow for Feature 1C time delay plus engine cranking and starting.	Starting control must be in the automatic position. Batteries must be charged and connected. Check wiring to engine starting contacts.	-
Transfer switch does not transfer the load to the emergency source after the engine-generator set starts.	Wait for Feature 2B time delay to time out.	Generator output circuit breaker must be closed. Generator frequency must be at least 95% of nominal (57 Hz for a 60 Hz system.) *	Voltmeter should read at least 90% of nominal phase to phase voltage between terminals EA and EC (or EL1 and EL2 for 2 pole switches)*
Transfer switch does not transfer the load to normal source when normal returns or when the <b>Transfer Test</b> button is released.	Wait for Feature 3A time delay to time out.	-	Voltmeter should read at least 90% of nominal phase to phase voltage between terminals NB and NC, NC and NA, and NA and NB (or NL1 and NL2 for 2 pole switches).
Gen. does not stop after load retransfer to normal source.	Wait for Feature 2E time delay to time out.	Starting control must be in the automatic position.	-
<i>Failure to Synchronize</i> light comes on.	Conditions of Normal or Emergency Sources not suitable for closed transition transfer. Recheck voltage and frequency of both sources. Press <b>Alarm Reset</b> pushbutton.		
<i>Extended Parallel Time</i> light comes on.	CN and CE contacts are closed longer than setting in the Controller. Open the disconnected source circuit breaker, then call your nearest ASI for assistance.		
<i>Transfer Switch Locked Out</i> light comes on.	Transfer lockout operation has occurred; transfer switch is disabled from automatic operation. Open the disconnected source circuit breaker, then call your nearest ASI for assistance.		

\* These are factory settings. Refer to **Group 5 Controller User's Guide**.

If the problem is isolated to circuits on the controller or the transfer switch, call your local ASCO Power Technologies sales office or ASI. In the United States, call 1-800-800-2726. In Canada, call 1-888-234-2726. Furnish the Serial No. and Catalog No. from the transfer switch nameplate.

# INDEX

## A

accepted lights, 1-6  
Alarm Reset, 2-2  
auxiliary circuits, 1-2

## B

bus connections, 1-1

## C

cable  
  lugs, 1-2  
  preparation, 1-2  
catalog number, inside cover  
cleaning, 2-1  
closed-transition transfer, 1-7  
connections  
  power, 1-1  
  engine start, 1-2  
controller, 1-1  
  disconnecting, 2-1  
  see *Controller User's Guide*

## E

electrical operation, 1-6  
emergency source accepted light,  
  1-6  
Extended Parallel Time, 1-6, 2-2

## F

Failure to Synchronize, 1-6, 2-2  
frequency, generator, 2-2  
functional test, 1-3, 1-4, 1-5, 1-6

## G

ground, controller, 1-2

## H

harness, 1-2  
  disconnect plugs, 2-1  
HELP  
  800-800-2726 (ASCO)  
  customer@asco.com

## I

inspection, 2-1  
installation, 1-1

## L

labels,  
  engine start contacts, 1-2  
  rating, cover  
lamp test, 1-6  
lights, 1-5, 1-6, 2-2  
lubrication, 2-1

## M

maintenance handle, 1-3, 1-4, 1-5  
maintenance, preventive, 2-1  
manual load transfer, 2-2  
  warning, 2-2  
manual operation, 1-3, 1-4, 1-5  
  illustration of, 1-3, 1-4, 1-5  
  warning, 1-3, 1-5

## N

nameplate, cover  
normal source accepted light, 1-6

## O

operation  
  electrical, 1-7  
  manual, 1-3, 1-4, 1-5  
  illustration of, 1-3, 1-4, 1-5  
  warning, 1-3, 1-5  
optional accessories  
  see *Controller User's Guide*

## P

parts, 2-1  
phase rotation check, 1-6  
problem, 2-2

## R

rating label, cover  
replacement parts, 2-1  
retransfer to normal, 1-7

## S

settings  
  see *Controller User's Guide*

## T

test, functional, 1-3, 1-4, 1-5, 1-6,  
  1-7  
time delays, 2-1  
  see *Controller User's Guide*  
transfer switch connected to  
  emergency light, 1-7, 2-1  
transfer switch connected to normal  
  light, 1-6, 2-1  
Transfer Switch Locked Out, 1-7,  
  2-2  
Transfer Test, 1-7, 2-2  
transfer to emergency, 1-7  
transfer to normal, 1-6, 2-1  
trouble-shooting, 2-2

## U

user controls locked, 1-7

## V

voltage checks, 1-5  
voltage, pickup and dropout settings  
  see *Controller User's Guide*