

# Accessory 18Z Installation

# for ASCO® 4000 Series Automatic Transfer Switches

The Accessory 18Z relay board can be added to 4000 Series Automatic Transfer Switches. This accessory includes three dedicated relays and one programmable relay as follows:

- Relay 1 – Emergency source acceptability contact
- Relay 2 – Normal source acceptability contact
- Relay 3 – Selective load disconnect contact
- Relay 4 – Can be configured via DIP switches (see page 2)

Each relay has form C contacts (1 pole double throw).

Contact ratings:            maximum 2 amps @ 30 V dc  
   minimum 10 uA @ 10 mV dc.

A second relay board can be added to provide a second set of form C contacts, if needed (Accessory 18Z2).

The Accessory 18Z relay board mounts directly behind the operator interface on the inside of the enclosure door. A second relay board (Acc. 18Z2) can be mounted (piggyback offset to the left) onto the first relay board. Internal connections are made through pin headers and sockets in the boards. Customer connections are made via removable terminal blocks on the right side. Refer to the wiring diagram for connections and wire sizes accepted by terminal block.

Kit **K770127** includes one Acc. 18Z relay board with mounting hardware. Two kits can be added to a 4000 Series ATS.

## Relay Board Installation

Tools required: 1/4" nut driver & small blade screwdriver

1. With all power OFF, open the enclosure door. Locate the operator interface (membrane controls) mounted on the inside of the enclosure door.
2. Install (clockwise) four standoffs (from the kit) onto the four studs on the right side of the operator interface board. Tighten the four standoffs with a 1/4" nutdriver.
3. Position the relay board (from the kit) so that the terminal block is on the right side. Carefully install the relay board onto the four standoffs (use the left and center holes) so the the socket at the top connects with the pin header on the operator interface board. If a second relay board will be installed, proceed to step 4. Then install (clockwise) four 6–32 elastic stop nuts (from the kit) to secure the assembly. Tighten the nuts.
4. To install a second relay board, remove the four elastic stop nuts (if installed) from the first relay board. Install four standoffs (from the kit) onto the four studs on the first relay board and tighten the standoffs. Position the second relay board like the first, but offset it to the left. Carefully install the second relay board onto the four standoffs (use the left and center holes) so the the socket at the top connects with the pin header on the first relay board. Then install four 6–32 elastic stop nuts to secure the assembly. Tighten the nuts.

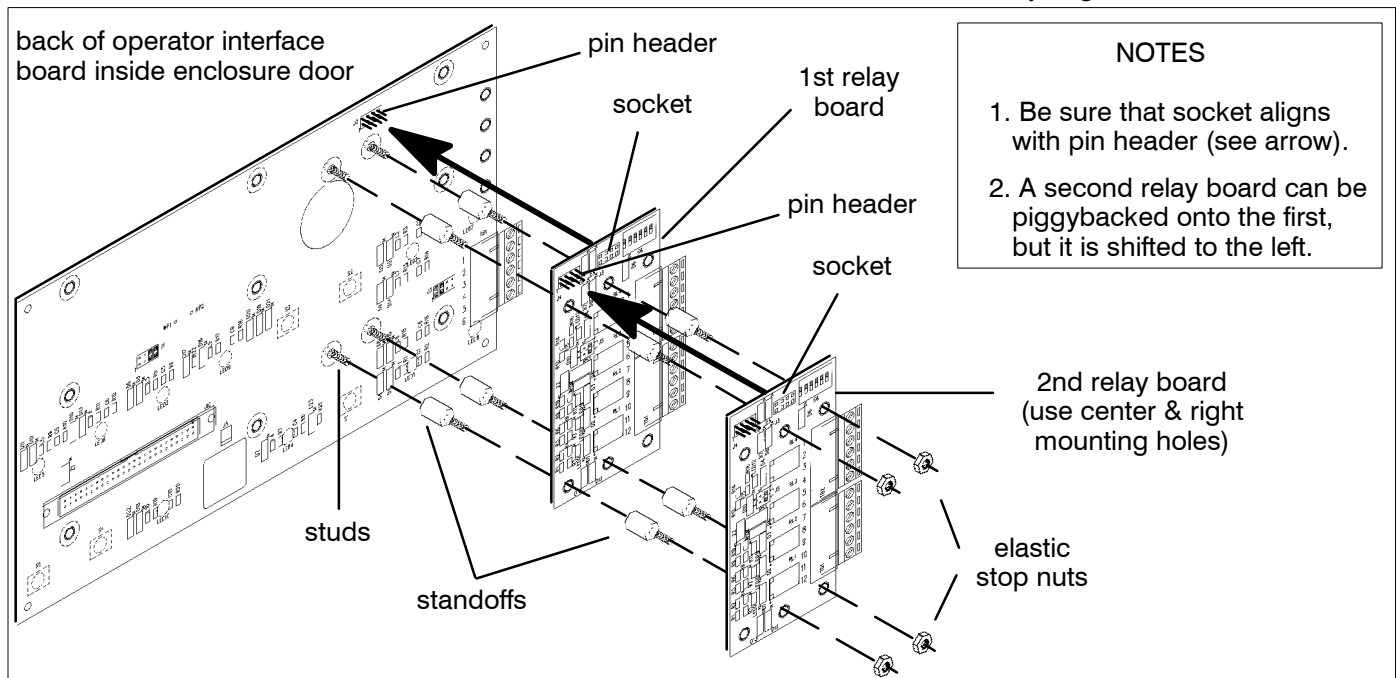
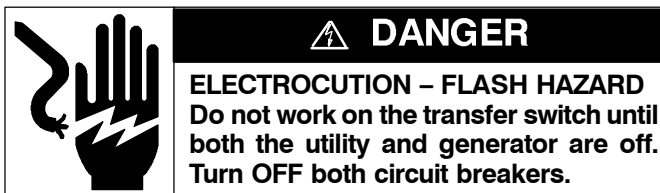

Figure 1. Accessory 18Z relay boards (mounted behind operator interface board).

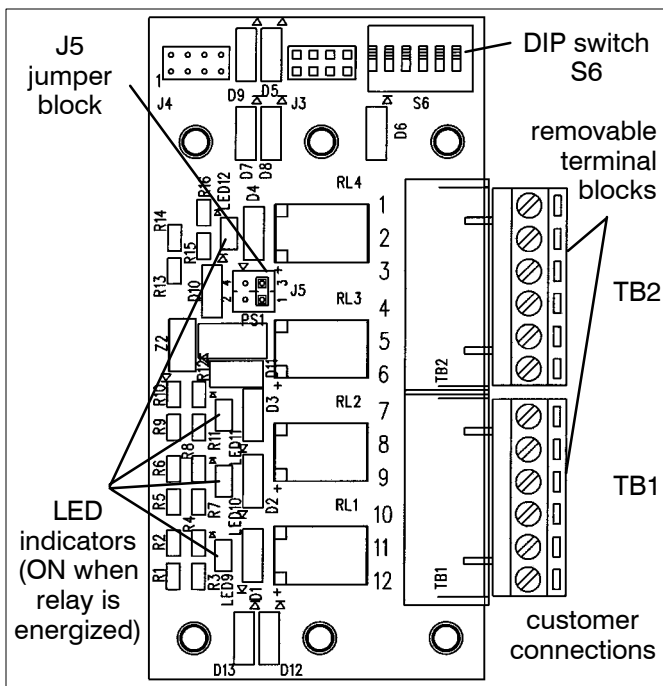

Figure 2. Relay board details.

**⚠ DANGER**

**ELECTROCUTION – FLASH HAZARD**  
Do not work on the transfer switch until both the utility and generator are off. Turn OFF both circuit breakers.

## Relay Board Connections

Make the necessary connections to removable terminal blocks TB1 and TB2. Refer to the wiring diagram and Table A.

Table A. Connections

Terminal	Contact	Relay	Accessory	Function
TB2 – 1	NC	RL4	see Table B	see Table B
TB2 – 2	common			
TB2 – 3	NO			
TB2 – 4	NC	RL3	31Z	selective load disconnect
TB2 – 5	common			
TB2 – 6	NO			
TB1 – 7	NC	RL2	18G	normal source accepted
TB1 – 8	common			
TB1 – 9	NO			
TB1 – 10	NC	RL1	18B	emerg. source accepted
TB1 – 11	common			
TB1 – 12	NO			

## J5 Jumper Blocks

The standard position of the J5 jumper blocks is between pins 1 & 3, and pins 2 & 4 (both jumpers vertical).

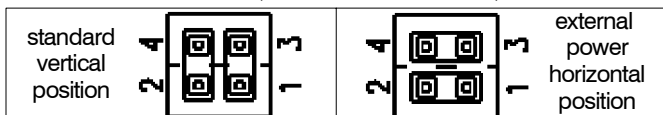

Figure 3. Jumper blocks.

## DIP Switch Settings for Relay 4

The function of Relay 4 (RL4) can be configured via DIP switch S6 on the top right corner of the relay board. Multiple conditions can be required to energize RL4 relay by activating more than one actuator. Refer to Table B and make the appropriate settings. Actuator 6 is not used.

Table B. Relay 4 – DIP Switch S6 Settings

Actuators ON	Actuator Positions	Accessory	Function
none		—	—
S6 – 1		18G	normal source accepted
S6 – 2		18B	emergency source accepted
S6 – 3		4ACTS only	extended parallel time
S6 – 4		4ACTS only	TS locked out
S6 – 5		4ACTS	fail to synch
		4ADTS	load disconnected
S6 – 1 S6 – 2		18G or 18B or external power	normal or emergency source accepted
S6 – 3 S6 – 4 S6 – 5		4ACTS	extended parallel or TS locked out or fail to synch

## External Power for Group 5 Controller

To provide external power to the controller do the following:

1. Move both jumper blocks to the horizontal positions (between pins 4 & 3 and 2 & 1); see Figure 3 (right side).
2. Set DIP switch S6 actuators 1 & 2 to ON (up), and actuators 3, 4, 5, & 6 to OFF (down).
3. Power supply rating must be nominal 24 V dc at 600 mA (min.) and be protected at its source. Connect it to TB2, terminal 1 negative (–) and terminal 2 positive (+);

When the controller is powered from either the normal or emergency sources RL4 relay is energized and the normally-closed relay contact is open, which disconnects the external source from the controller. When both normal and emergency sources are lost, RL4 relay is deenergized and RL4 relay contact closes. Power from the external source now flows through RL4 relay contact and into controller.

With an external power supply energized, the controller's Feature 1C time delay range (override momentary Normal source outages) is extended to 60 seconds. Refer to the Group 5 User's Guide that accompanies the transfer switch.