

# THREE PHASE WIRING FOR ASCO® 4000 SERIES TRANSFER SWITCHES TYPES J4ATS & J4NTS RATED 260, 400 & 600 AMPERES

## FEATURES, SETTINGS, OPERATION, ACCESSORIES & NOTES

THE FOLLOWING FEATURES AND RELATED SETTINGS ARE PART OF THE GROUP 5 CONTROL PANEL'S USER CONFIGURABLE PARAMETERS. FOR DETAILED INFORMATION REGARDING THE CONFIGURATION OF THESE PARAMETERS AND OTHER FEATURES OF THE GROUP 5 CONTROL PANEL, REFER TO THE GROUP 5 CONTROL PANEL FOR ASCO® 4000 SERIES TRANSFER SWITCHES USER'S GUIDE (PART NO. 381333-126) PROVIDED WITH EVERY 4000 SERIES TRANSFER SWITCH.

THE NOMINAL OPERATING VOLTAGE & FREQUENCY IS PRE-PROGRAMMED AT THE FACTORY BASED ON THE NAMEPLATE DATA PRINTED ON THE TRANSFER SWITCH & CONTROL PANEL NAMEPLATES.

### VOLTAGE & FREQUENCY SENSING

THE FOLLOWING SETTINGS ARE EXPRESSED AS A PERCENTAGE OF THE CONTROL PANEL'S NOMINAL VOLTAGE SETTING UNLESS STATED OTHERWISE. ALL SETTINGS ARE ADJUSTABLE IN INCREMENTS OF 1%.

A. RMS VOLTAGE SENSING ON ALL PHASES OF THE NORMAL & EMERGENCY SOURCES.

PARAMETER	RANGE OF SETTINGS	DEFAULT SETTING
NORMAL VOLTAGE DROPOUT	70-98%	85%
NORMAL VOLTAGE PICKUP	85-100%	90%
NORMAL OVER VOLTAGE TRIP	102-115%	OFF
NORMAL VOLTAGE UNBALANCE	YES/NO	NO
NORMAL VOLTAGE UNBALANCE DROPOUT	5-20% OF AVG. NORMAL VOLTAGE	20% (if ON)
NORMAL VOLTAGE UNBALANCE PICKUP	3-18% OF AVG. NORMAL VOLTAGE	10% (if ON)
EMERGENCY VOLTAGE DROPOUT	70-98%	75%
EMERGENCY VOLTAGE PICKUP	85-100%	90%
EMERGENCY OVER VOLTAGE TRIP	102-115%	OFF
EMERGENCY VOLTAGE UNBALANCE	YES/NO	NO
EMERGENCY VOLTAGE UNBALANCE DROPOUT	5-20% OF AVG. EMERGENCY VOLTAGE	20% (if ON)
EMERGENCY VOLTAGE UNBALANCE PICKUP	3-18% OF AVG. EMERGENCY VOLTAGE	10% (if ON)

B. FREQUENCY SENSING OF THE NORMAL & EMERGENCY SOURCES.

PARAMETER	RANGE OF SETTINGS	DEFAULT SETTING
NORMAL FREQUENCY DROPOUT	85-98%	90%
NORMAL FREQUENCY PICKUP	90-100%	95%
NORMAL OVER FREQUENCY TRIP	102-110%	OFF
EMERGENCY FREQUENCY DROPOUT	85-98%	90%
EMERGENCY FREQUENCY PICKUP	90-100%	95%
EMERGENCY OVER FREQUENCY TRIP	102-110%	OFF

### TIME DELAYS

THE FOLLOWING TIME DELAY SETTINGS ALL HAVE AN ADJUSTABLE RANGE OF 0-60 min 59 sec UNLESS STATED OTHERWISE. ADJUSTABLE IN INCREMENTS OF 1 sec.

NOTE: SOME TIME DELAYS MAY BE EFFECTED BY CUSTOMER REQUESTED ACCESSORIES PROVIDED WITH THE UNIT. REFER TO THE DESCRIPTIONS PROVIDED UNDER THE "ACCESSORIES" NOTES ON THIS PAGE.

FEATURE	NAME	DEFAULT SETTING
1C	NORMAL SOURCE FAILURE TO ENGINE START	1 sec
2B	TRANSFER TO EMERGENCY ON AVAILABILITY OF EMERGENCY SOURCE	0 sec
1F	EMERGENCY SOURCE FAILURE RETRANSFER (NORMAL SOURCE AVAILABLE)	0 sec
2E	ENGINE COOLDOWN FOLLOWING RETRANSFER TO NORMAL	5 min
3A	RETRANSFER TO NORMAL (NORMAL FAILURE MODE)	30 min
3A	RETRANSFER TO NORMAL (TEST MODE)	30 sec
-	DELAYED TRANSFER (LOAD "OFF" TIME), [0-5 min 59 sec]	3 sec

DESCRIPTIONS OF TIME DELAYS:

FEAT. 1C - DELAY ON NORMAL SOURCE OUTAGE. STARTS ON FAILURE OF NORMAL SOURCE. RESETS IF NORMAL SOURCE IS ACCEPTED BEFORE EXPIRATION. INHIBITS ENGINE STARTING AND AUTOMATIC TRANSFER UNTIL EXPIRATION.

FEAT. 2B - DELAY PRIOR TO TRANSFER TO THE EMERGENCY SOURCE. DELAY STARTS ON EXPIRATION OF FEAT. 1C AND WHEN THE EMERGENCY SOURCE HAS BEEN ACCEPTED. DELAY RESETS IF THE EMERGENCY SOURCE FAILS PRIOR TO EXPIRATION. UPON EXPIRATION, TRANSFER TO EMERGENCY IS INITIATED ON AUTOMATIC UNITS (4ATS) UNLESS THE NORMAL SOURCE HAS RECOVERED AND THE "COMMIT TO TRANSFER" FEATURE IS SET TO "NO" COMMIT. PROVIDES A PERIOD FOR EMERGENCY SOURCE STABILIZATION OR STAGING OF MULTIPLE TRANSFER SWITCH CONTROLLED LOADS TO THE EMERGENCY SOURCE.

FEAT. 1F - DELAY ON RETRANSFER TO NORMAL IN THE EVENT OF EMERGENCY SOURCE FAILURE. DELAY BEGINS ON FAILURE OF THE EMERGENCY SOURCE. IF THE NORMAL SOURCE IS ACCEPTABLE, UPON EXPIRATION OF THE DELAY, RETRANSFER TO NORMAL WILL BE INITIATED ON AUTOMATIC UNITS (4ATS).

FEAT. 2E - DELAY ON ENGINE SHUTDOWN (ENGINE COOL DOWN PERIOD). DELAY STARTS FOLLOWING RETRANSFER TO THE NORMAL SOURCE. PROVIDES A PERIOD FOR THE ENGINE-GENERATOR SET TO RUN UNLOADED PRIOR TO SHUTDOWN.

FEAT. 3A - RETRANSFER TO NORMAL DELAY (NORMAL FAILURE MODE)  
DELAY STARTS WHEN NORMAL SOURCE IS ACCEPTED (FOLLOWING IT'S FAILURE) AND WHILE THE LOAD IS CONNECTED TO EMERGENCY. RESETS IF NORMAL FAILS PRIOR TO EXPIRATION OR IF THE EMERGENCY SOURCE FAILS BEFORE EXPIRATION AND FEAT. 1F EXPIRES (AUTOMATIC BYPASS ON EMERGENCY SOURCE FAILURE). PROVIDES A PERIOD FOR THE NORMAL SOURCE TO STABILIZE PRIOR TO AUTOMATIC (4ATS) OR MANUAL (4NTS) RETRANSFER.

FEAT. 3A - RETRANSFER TO NORMAL DELAY (TEST MODE)  
DELAY STARTS FOLLOWING A USER INITIATED "TRANSFER TEST" WHEN THE "RETRANSFER TO NORMAL" KEY PAD IS DEPRESSED ON AUTOMATIC UNITS (4ATS) AND WHILE THE LOAD IS CONNECTED TO EMERGENCY. RESETS IF NORMAL FAILS PRIOR TO EXPIRATION OR IF THE EMERGENCY SOURCE FAILS BEFORE EXPIRATION AND FEAT. 1F EXPIRES (AUTOMATIC BYPASS ON EMERGENCY SOURCE FAILURE).

### MOTOR LOAD TRANSFER FEATURE

FEAT. 27 - INPHASE TRANSFER CONTROL LOGIC TO INITIATE AN INPHASE TRANSFER OF LOADS BETWEEN LIVE SOURCES. USED TO PREVENT NUISANCE TRIPPING OF CIRCUIT BREAKERS AND POSSIBLE DAMAGE TO MECHANICAL LOADS CAUSED BY OUT OF PHASE TRANSFER.  
ACTIVATED VIA THE GROUP 5 CONTROL PANEL USER INTERFACE (TRANSFER CONTROL CENTER) BY SELECTING "IN-PHASE MONITOR ENABLE" = YES. AN ADJUSTABLE DELAY (0.0-3.0 sec, FACTORY SET TO 1.5 sec, IN INCREMENTS OF 0.1 sec) DELAYS SENSING TO PERMIT STABILIZATION OF THE SOURCES PRIOR TO SENSING. FACTORY SETTING IS DISABLED UNLESS SPECIFIED TO BE FACTORY ACTIVATED AT THE TIME OF ORDER.

### ENGINE EXERCISER

THE ENGINE EXERCISER FEATURE PROVIDES A MEANS TO PERFORM AUTOMATIC EXERCISING OF THE ENGINE-GENERATOR SET EITHER WITH OR WITHOUT LOAD TRANSFER FOR AUTOMATIC UNITS (4ATS) OR WITHOUT LOAD TRANSFER FOR NON-AUTOMATIC UNITS (4NTS).

THE USER CAN PROGRAM UP TO SEVEN DIFFERENT EXERCISE ROUTINES. EACH ROUTINE INCLUDES:  
1. ENABLE OR DISABLE THE ROUTINE  
2. ENABLE OR DISABLE TRANSFER OF THE LOAD DURING THE ROUTINE  
3. SET START TIME OF ROUTINE -  
- TIME OF DAY  
- DAY OF WEEK  
- WEEK OF MONTH (1st, 2nd, 3rd, 4th, ALTERNATE OR ALL)  
4. SET THE DURATION OF THE ROUTINE

PARAMETER	RANGE OF SETTING	DEFAULT SETTING
MONTH (CLOCK SET)	JAN FEB MAR APR MAY JUN JUL AUG SEP OCT NOV DEC	CURRENT DATE
DAY	1-31	
YEAR	00-99	
HOUR	0-23	Eastern Standard Time
MINUTE	0-59	
ENABLE ROUTINE (ROUTINE 1-7)	YES/NO	NO
TRANSFER LOAD	YES/NO	NO
START HOUR	0-23	0
START MINUTE	0-59	0
RUN WEEK	ALL, ALTERNATE, 1st, 2nd, 3rd, 4th, 5th	ALL
RUN DAY	SUN MON TUE WED THU FRI SAT	SUN
DURATION HOURS	0-23	0
DURATION MINUTES	0-59	0

### OPERATION

IF THE NORMAL SOURCE FAILS, THE TRANSFER SWITCH INITIATES STARTING OF THE ENGINE-GENERATOR SET. WHEN PROPER VOLTAGE AND FREQUENCY HAVE BEEN ATTAINED, THE LOAD WILL BE TRANSFERRED ON AUTOMATIC UNITS (4ATS) OR PERMITTED TO BE MANUALLY TRANSFERRED ON NON-AUTOMATIC UNITS (4NTS) TO THE EMERGENCY SOURCE.

WHEN THE NORMAL SOURCE IS RESTORED FOR THE DURATION OF THE FEATURE 3A (RETRANSFER TO NORMAL TIME DELAY) SETTING AND FOLLOWING OPERATION OF THE "TRANSFER TO NORMAL" KEYPAD ON NON-AUTOMATIC UNITS (4NTS), THE LOAD WILL BE RETRANSFERRED TO THE NORMAL SOURCE.

THE ENGINE WILL CONTINUE TO RUN FOR THE ENGINE COOL DOWN PERIOD, FEATURE 2E.

### SIGNALS & AUXILIARIES

A. FEATURES 7 & 8- ENGINE START SIGNAL

SIGNAL INITIATED BY DROPOUT OF CONTROL PANEL RELAY (NR) FOLLOWING EXPIRATION OF THE FEATURE 1C TIME DELAY (DELAY TO OVERRIDE MOMENTARY NORMAL SOURCE OUTAGES). THE 1C DELAY IS BYPASSED ON NON-AUTOMATIC UNITS (4NTS), WHEN TRANSFER IS INITIATED BY OPERATION OF THE "TRANSFER TO NORMAL" KEYPAD AND THE NORMAL SOURCE IS AVAILABLE. FEATURE 7 CLOSSES TO SIGNAL ENGINE START. FEATURE 8 OPENS TO SIGNAL ENGINE START. ENGINE STARTING SIGNAL RESETS FOLLOWING RETRANSFER TO THE NORMAL SOURCE AND EXPIRATION OF THE FEATURE 2E (ENGINE COOL DOWN) TIME DELAY. FEATURES 7 & 8 ARE PROVIDED AS A SINGLE FORM C CONTACT CONNECTED TO THE FIELD CONNECTIONS TERMINAL BLOCK (TB) LOCATED ON THE TRANSFER SWITCH FRAME. CONTACT RATED 5 AMPS AT 32 VDC/120VAC RESISTIVE.

B. FEATURES 14AA & 14BA - TRANSFER SWITCH AUXILIARY POSITION INDICATING CONTACTS. TWO (2) FORM A CONTACTS EACH TO INDICATE CONNECTION OF THE TRANSFER SWITCH TO NORMAL (14A) OR EMERGENCY (14B). CONTACTS CONNECTED TO THE FIELD CONNECTIONS TERMINAL BLOCK (TB) LOCATED ON THE TRANSFER SWITCH FRAME. CONTACTS RATED 10 AMPS, 32 VDC, 250 VAC.

C. FEATURE 17 - REMOTE TRANSFER TO EMERGENCY.  
REQUIRES A CUSTOMER SUPPLIED NORMALLY OPEN CONTACT. CLOSING OF THE CONTACT CAUSES ENGINE START AND TRANSFER TO THE EMERGENCY SOURCE ON AUTOMATIC UNITS (4ATS). OPENING OF THE CONTACT ACTIVATES THE FEATURE 3A (RETRANSFER TO NORMAL) DELAY PRIOR TO RETRANSFER. IN THE EVENT THE EMERGENCY SOURCE FAILS WHILE THE TRANSFER SWITCH IS CONNECTED TO EMERGENCY AND THE REMOTE CONTACT IS CLOSED, THE TRANSFER SWITCH WILL RETRANSFER TO THE NORMAL SOURCE. LOCATED ON TERMINAL BLOCK (TB1) ON THE REAR OF THE OPERATOR INTERFACE MODULE ON THE FRONT DOOR.

### USER CONTROLS AND INDICATIONS

A. FEATURES 5 & 6B - "TRANSFER TEST" & "RETRANSFER TO NORMAL" KEYPAD CONTROLS. STANDARD ON AUTOMATIC UNITS (4ATS).

"TRANSFER TEST" KEYPAD:  
OPERATION CAUSES A NORMAL SOURCE FAILURE SEQUENCE. ACTIVATE AND HOLD FOR AT LEAST 15 SECONDS TO ALLOW TIME FOR THE ENGINE-GENERATOR TO START.

"RETRANSFER TO NORMAL" KEYPAD:  
OPERATION WILL BYPASS THE FEATURE 3A (RETRANSFER TO NORMAL DELAY) INITIATING RETRANSFER TO THE NORMAL SOURCE.

FEATURE 6Z & 6C - MANUAL TRANSFER CONTROL, "TRANSFER TO EMERGENCY" & "TRANSFER TO NORMAL" KEYPAD CONTROLS. STANDARD ON NON-AUTOMATIC UNITS (4NTS).

"TRANSFER TO EMERGENCY" KEYPAD:  
OPERATION CAUSES IMMEDIATE ENGINE START IF NORMAL IS AVAILABLE AND TRANSFER TO THE EMERGENCY SOURCE WHEN THE EMERGENCY SOURCE IS AVAILABLE. TRANSFER SWITCH WILL REMAIN CONNECTED TO THE EMERGENCY SOURCE UNTIL THE UNIT IS MANUALLY RETRANSFERRED TO THE NORMAL SOURCE.

"RETRANSFER TO NORMAL" KEYPAD:  
OPERATION CAUSES TRANSFER TO THE NORMAL SOURCE IF IT IS AVAILABLE. THE ENGINE START SIGNAL WILL RUN FOR THE ACCESSORY 2E DELAY ON ENGINE SHUTDOWN FOLLOWING TRANSFER. THE TRANSFER SWITCH WILL REMAIN CONNECTED TO THE NORMAL SOURCE UNTIL THE UNIT IS MANUALLY TRANSFERRED TO THE EMERGENCY SOURCE.

B. FEATURES 9A & 9B - TRANSFER SWITCH POSITION INDICATORS.

FEATURE 9A: TRANSFER SWITCH CLOSED ON NORMAL (GREEN LED)  
FEATURE 9B: TRANSFER SWITCH CLOSED ON EMERGENCY (RED LED)

C. FEATURES 9C & 9D - SOURCE ACCEPTANCE INDICATORS.

FEATURE 9C: NORMAL SOURCE ACCEPTED (GREEN LED)  
FEATURE 9D: EMERGENCY SOURCE ACCEPTED (RED LED)

### OPTIONAL ACCESSORIES

A. ACCESSORY 14AC & 14BC - TWO (2) ADDITIONAL TRANSFER SWITCH AUXILIARY POSITION INDICATING CONTACTS EACH TO INDICATE CONNECTION OF THE TRANSFER SWITCH TO NORMAL (14A) OR EMERGENCY (14B). CONTACTS CONNECTED TO THE FIELD CONNECTIONS TERMINAL BLOCK (TB) LOCATED ON THE TRANSFER SWITCH FRAME. CONTACTS RATED 10 AMPS, 32 VDC, 250 VAC.

B. ACCESSORY 18Z & 18Z2 - OPTION RELAY MODULE. PROVIDES A RELAY MODULE ASSEMBLY THAT CONNECTS TO THE REAR OF THE USER INTERFACE MODULE. ACCESSORY 18Z PROVIDES ONE (1) RELAY MODULE & ACCESSORY 18Z2 PROVIDES TWO (2) RELAY MODULES.

EACH RELAY MODULE PROVIDES 4 INDEPENDANT, FORM C RELAY OUTPUTS EACH RATED 2 AMPS, 30 VDC MAX. THE RELAY PROVIDE THE FOLLOWING SIGNALS;

RELAY 1 (RL1) ENERGIZES IF THE EMERGENCY SOURCE HAS BEEN ACCEPTED BY THE CONTROLLER.

RELAY 2 (RL2) ENERGIZES IF THE NORMAL SOURCE HAS BEEN ACCEPTED BY THE CONTROLLER.

RELAY 3 (RL3) ENERGIZES IF THE CONTROLLER'S LOAD DISCONNECT SIGNAL IS ACTIVE. (FEATURE 31, REFER TO THE GROUP 5 CONTROLLER USER'S MANUAL, PN 381333-126).

RELAY 4 (RL4) USER CONFIGURED OUTPUT THAT CAN BE USER DEFINED TO OPERATE AS FOLLOWS;

- \* SAME AS RELAY 1.
- \* SAME AS RELAY 2.
- \* DE-ENERGIZES IF BOTH SOURCES ARE UNACCEPTABLE AND PROVIDES ONBOARD JUMPER TO PERMIT THE RELAY TO BE USED TO ALLOW AN EXTERNAL 24 VDC SOURCE TO POWER THE CONTROLLER FOR EXTENDED ENGINE STARTING TIME DELAY SETTINGS WHEN POWER IS NOT AVAILABLE.

REFER TO INSTRUCTION SHEET PN 381339-260 FOR INSTRUCTIONS.

### GENERAL NOTES

- SWITCH SHOWN DE-ENERGIZED AND CONNECTED TO THE NORMAL SOURCE.
- DEVICE SYMBOLS AND DESIGNATIONS ARE IN ACCORDANCE WITH NEMA PUBLICATION ICS 1-1983, PART 1-101A.
- ALL WIRING IS #16 AWG, TINNED, STRANDED COPPER UNLESS OTHERWISE INDICATED.
- ON TERMINAL BLOCKS INDICATES AVAILABLE FIELD CONNECTION POINT.
- ON TERMINAL BLOCKS INDICATES FACTORY CONNECTION POINT.
- CONTROL AND ACCESSORY WIRING IS ROUTED IN ACCORDANCE WITH ASCO ASSEMBLY PROCEDURE GS451261.
- AN OPERATOR'S MANUAL IS FURNISHED WITH EACH TRANSFER SWITCH. REFER TO THIS PUBLICATION PRIOR TO INSTALLATION AND OPERATION OF THE UNIT.

BASE CATALOG NUMBER				CATALOG NUMBER SUFFIXES				EXPLANATION OF CATALOG NUMBER CODES														
TS FRAME	CATALOG TYPE	NEUTRAL TYPE	PHASE POLES	AMPS	VOLT CODE	CONTROLLER	OPTIONAL ACCESSORY	ENCLOSURE CODE	CATALOG TYPE		NEUTRAL TYPE		VOLTAGE CODES		ENCLOSURE CODES							
									CODE	DESCRIPTION	CODE	DESCRIPTION	CODE	NOMINAL VOLTAGE	CODE	TYPE	DESCRIPTION					
									4ATS	AUTOMATIC	BLANK	NONE			BLANK	C	OPEN TYPE (NO ENCLOSURE)					
									4NTS	MANUAL	A	SOLID				1	GENERAL PURPOSE, INDOOR					
											B	SWITCHING	C	208	E	2	INDOOR, WATER & DUST RESISTANT					
											C	OVERLAPPING	D	220	F	3R	OUTDOOR, RAINPROOF, SLEET & ICE RESISTANT					
											D		E	230	G	4	INDOOR/OUTDOOR, WATERTIGHT & DUSTTIGHT					
											E		F	240	H	4X	TYPE 4 PLUS CORROSION RESISTANCE (STAINLESS STEEL)					
											F		H	380	J	4X	TYPE 4 PLUS CORROSION RESISTANCE (FIBERGLASS)					
											G		I	400	K	7	EXPLOSION PROOF					
											H		J	415	L	12	INDOOR, INDUSTRIAL ENVIRONMENTS, OILTIGHT & DUSTTIGHT					
											I		K	440			(SECURE ENCLOSURES)					
											J		L	460	M	3R	OUTDOOR, RAINPROOF, SLEET & ICE RESISTANT					
											K		M	480	N	4	INDOOR/OUTDOOR, WATERTIGHT & DUSTTIGHT					
											L		N	550	P	4X	TYPE 4 PLUS CORROSION RESISTANCE (STAINLESS STEEL)					
											M		O	575	Q	12	INDOOR, INDUSTRIAL ENVIRONMENTS, OILTIGHT & DUSTTIGHT					
											N		P	600	R							
											O		Q									
											P		R									
											Q											
											R											

CATALOG NUMBER \_\_\_\_\_

ASCO® CERTIFIED TO

S.O. \_\_\_\_\_

BY \_\_\_\_\_

DATE \_\_\_\_\_

FORM REV B

PROJECT NAME: \_\_\_\_\_

WIRING DIAGRAM

4000 SERIES (J4ATS/J4NTS)

GROUP 5 CONTROLS

THIRD ANGLE PROJECTION

BY DATE MANUFACTURING TOLERANCES TO BE IN ACCORDANCE WITH ASCO PROCEDURE MP-1-003. FOR PLASTIC PARTS SEE MP-1-055.

CHECKED JPB 7/26/05 ASSEM. REF. NO.

DRAWING APPROVAL JPB 7/26/05 PROPERTY OF ASCO POWER TECHNOLOGIES. USE PERMITTED FOR OUR WORK ONLY. ALL RIGHTS OF DESIGN OR INVENTION ARE RESERVED.

FINAL APPROVAL JPB 7/26/05

ASCO POWER TECHNOLOGIES, L.P. FLORHAM PARK, NEW JERSEY 07932 U.S.A.

B 205832 JPB JPB 9/8/05

SEE ECN

A 205582 JPB JPB 8/18/05

SEE ECN

205285 JPB JPB 7/26/05

ISSUE

CHANGE LETTER ECN NO. BY APP. DATE

SUBSIDIARY DISTRIBUTION

AE AN AM AU AL

CH AV AA PS AR

AG AP AC AS

COMPUTER GENERATED DRAWING

SCALE 1:1 ACAD FILE

SIZE DWG. NO. DS781123

CHANGE LETTER ECN NO. 205832 SHEET 1 OF 6

# FIELD CONNECTIONS

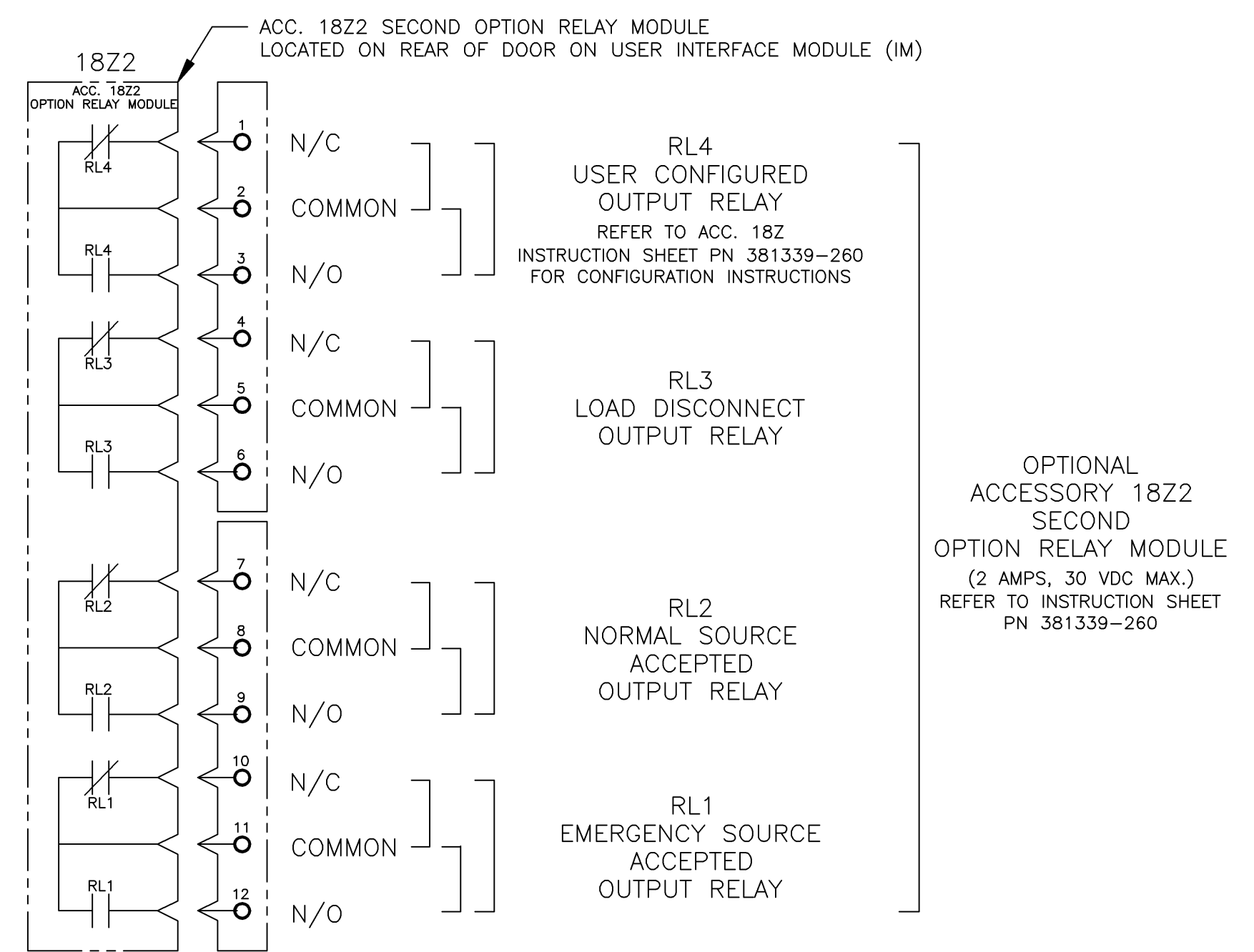
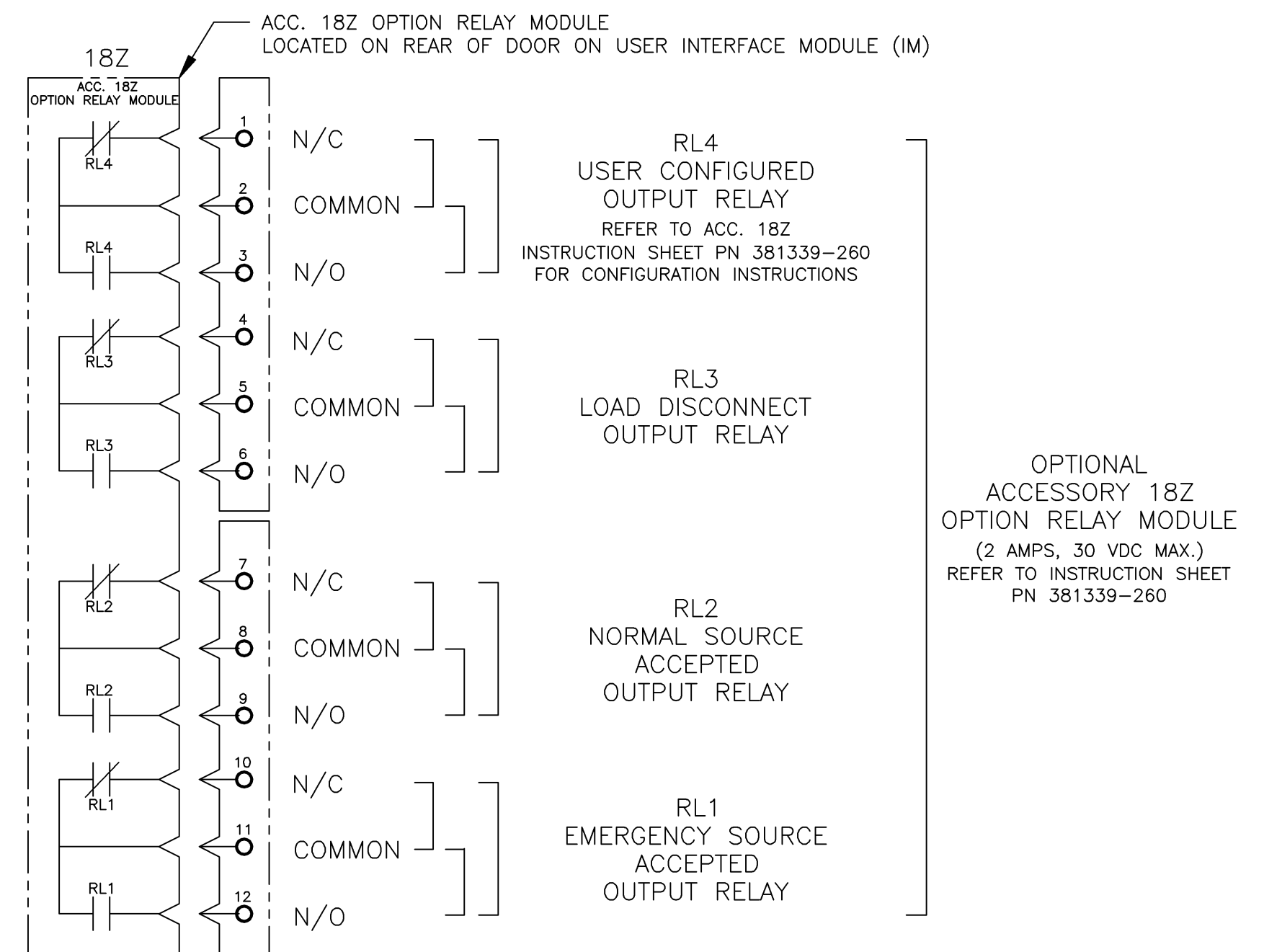
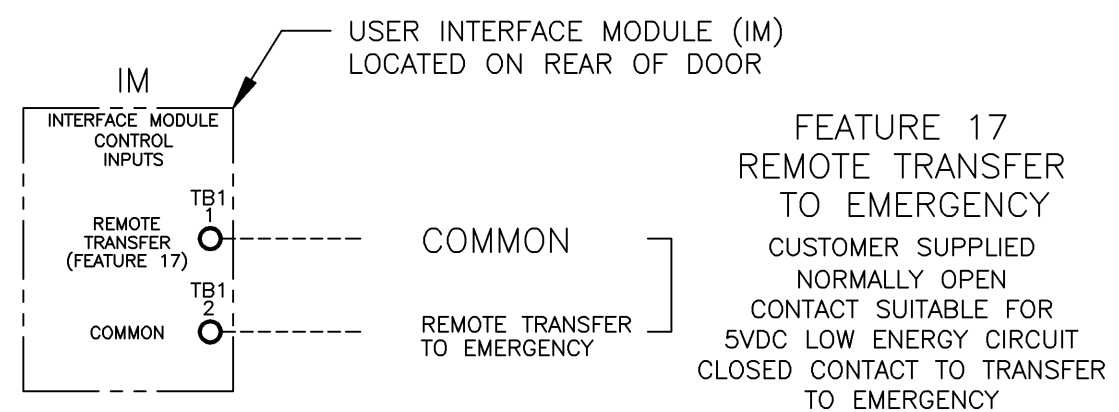
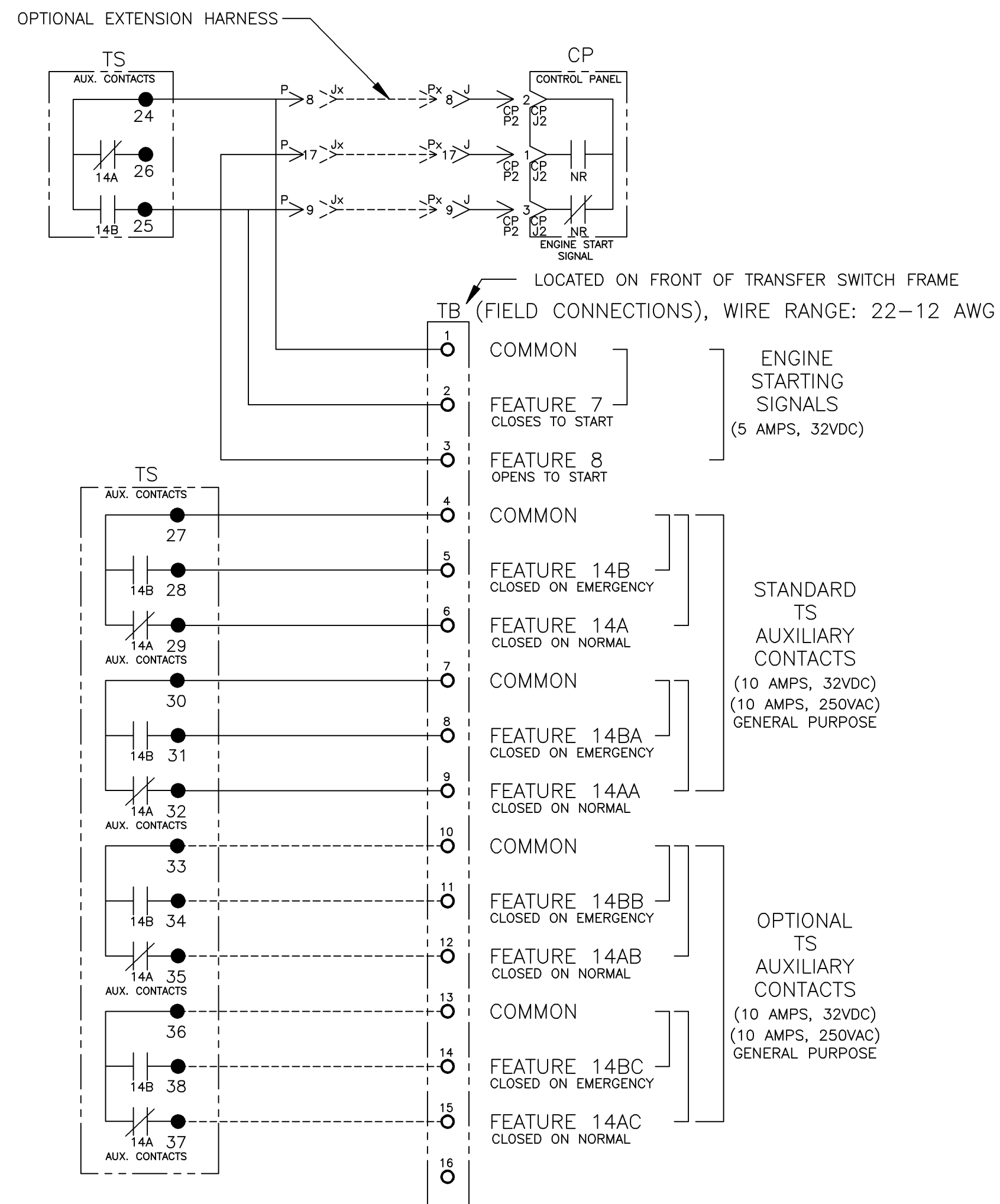

B	205832	JPB	JPB	9/8/05
SEE ECN				
A	205582	JPB	JPB	8/18/05
SEE ECN				
-	205285	JPB	JPB	7/26/05
ISSUE				

PROJECT NAME:		CHANGE LETTER		ECN NO.	BY	APP.	DATE
WIRING DIAGRAM		THIRD ANGLE PROJECTION		SUBSIDIARY DISTRIBUTION			
4000 SERIES (J4ATS/J4NTS)		ASCO POWER TECHNOLOGIES, L.P.		<input type="checkbox"/> AE <input type="checkbox"/> AN <input type="checkbox"/> AM <input type="checkbox"/> AJ <input type="checkbox"/> AL <input type="checkbox"/> <input type="checkbox"/> CH <input type="checkbox"/> AV <input type="checkbox"/> AA <input type="checkbox"/> PS <input type="checkbox"/> AR <input type="checkbox"/> <input type="checkbox"/> AG <input type="checkbox"/> AP <input type="checkbox"/> AC <input type="checkbox"/> AS <input type="checkbox"/>			
DRAWN BY: JPB 7/26/05		MANUFACTURING TOLERANCES TO BE IN ACCORDANCE WITH ASCO PROCEDURE MP-1-003. FOR PLASTIC PARTS SEE MP-1-055		COMPUTER GENERATED DRAWING			
CHECKED BY: JPB 7/26/05		PROPERTY OF ASCO POWER TECHNOLOGIES. USE PERMITTED FOR OUR WORK ONLY. ALL RIGHTS OF DESIGN OR INVENTION ARE RESERVED.		SCALE: 1:1 ACAD FILE			
DRAWING APPROVAL: JPB 7/26/05		ASCO POWER TECHNOLOGIES, L.P. FLORHAM PARK, NEW JERSEY 07932 U.S.A.		SIZE: DWS 781123			
FINAL APPROVAL:		ASCO		CHANGE LETTER: B ECN NO.: 205832 SHEET NO.: 2 OF 6			

MAIN POWER POLES

TS OPERATOR CIRCUIT

EMERGENCY

NORMAL

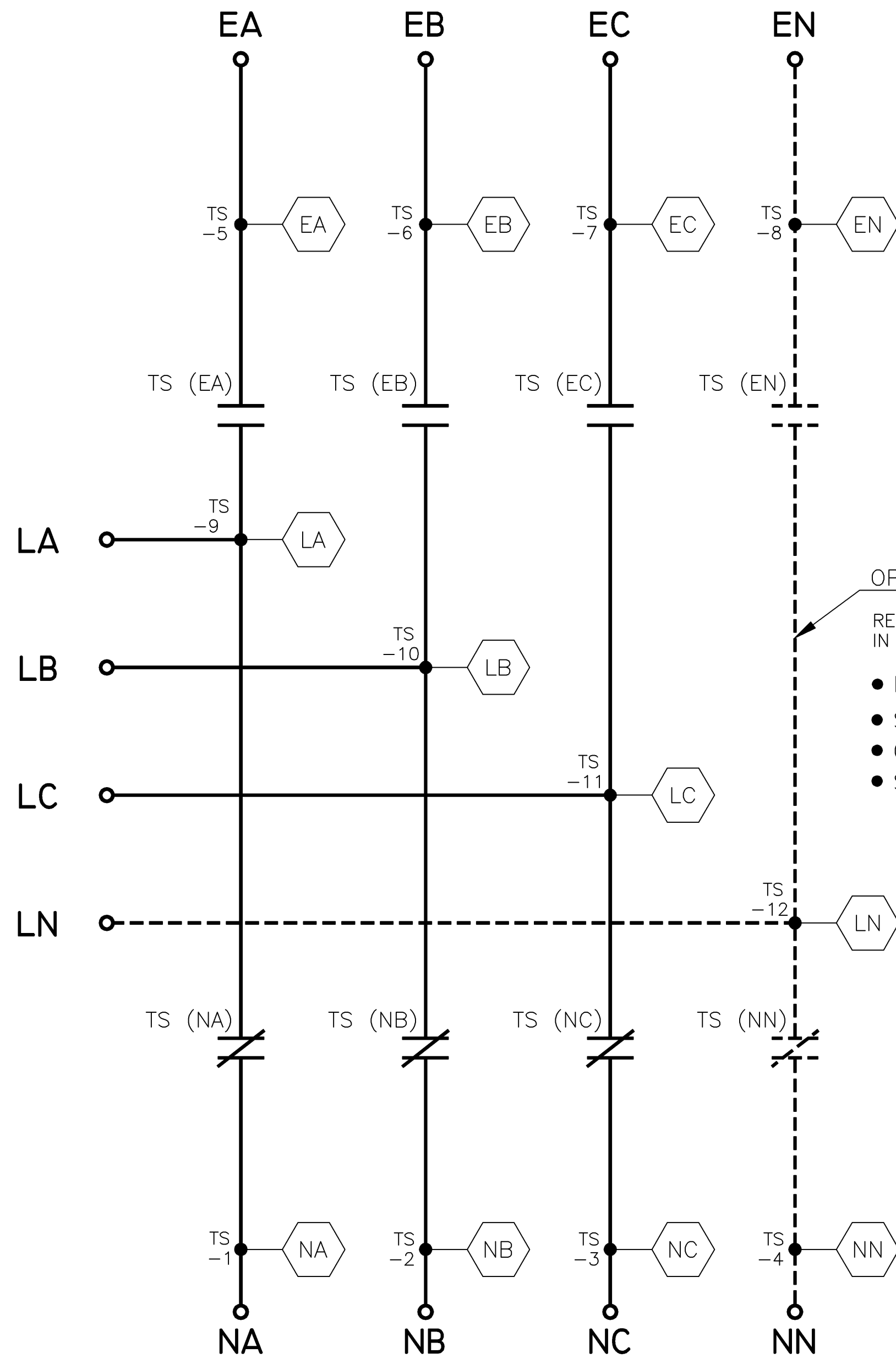

OPTIONAL NEUTRAL TYPES

REFER TO "EXPLANATION OF CATALOG NUMBER CODES" IN CATALOG NUMBER CHART ON SHEET 1.

- NONE
- SWITCHING CONTACTS
- OVERLAPPING CONTACTS
- SOLID BUS PLATE

NORMAL

NOTE: ATS SHOWN CLOSED ON NORMAL SOURCE.

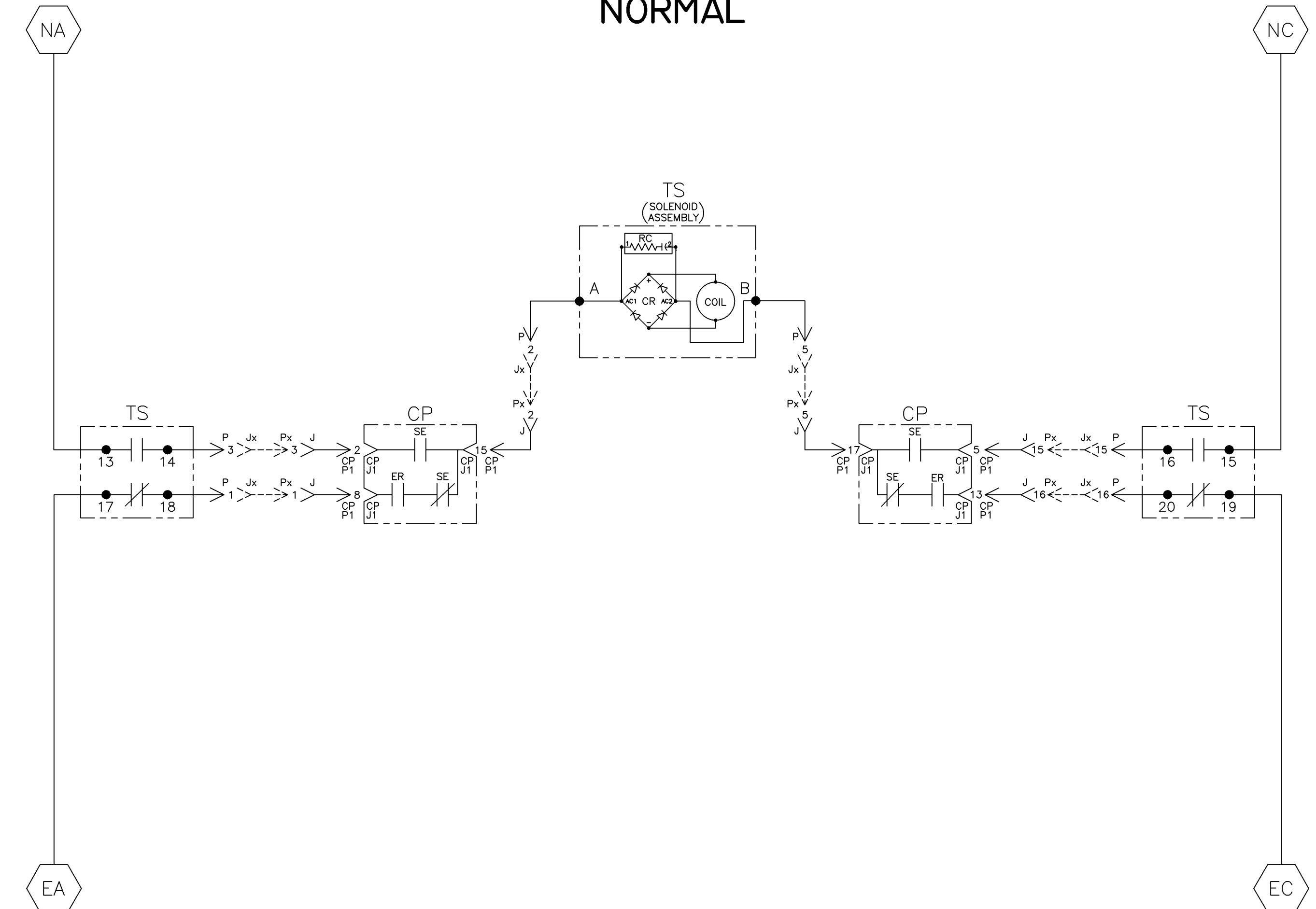

TS	SOLENOID POSITION			
	CLOSED	BEFORE	BEFORE	CLOSED
	NORMAL	TDC	TDC	EMERG
13-14		>	<	
15-16				
17-18				
19-20				

TDC (TOP DEAD CENTER)  
TRANSFER SWITCH TEST & ADJUSTMENT PROCEDURE  
SPECIFIES CONTROL CUT-OFF (CONTACT OPENING)  
SETTING.

PROJECT NAME:		WIRING DIAGRAM		THIRD ANGLE PROJECTION	
4000 SERIES (J4ATS/J4NTS)		GROUP 5 CONTROLS		COMPUTER GENERATED DRAWING	
DRAWN BY	JPB	DATE	7/26/05	SCALE	1:1
CHECKED	JPB	DATE	7/26/05	ACAD	FILE
DRAFTING		DATE		SIZE	DWG. NO.
APPROVAL		DATE		DS	781123
FINAL	JPB	DATE	7/26/05	CHANGE	LETTER
				ECN	NO. 205832
				ASSEMBLY	NO. 3 OF 6

ASCO POWER TECHNOLOGIES, L.P.  
FLORHAM PARK, NEW JERSEY 07932 U.S.A.

EMERGENCY SOURCE CIRCUITS

ADDITIONAL CIRCUITS

EMERGENCY

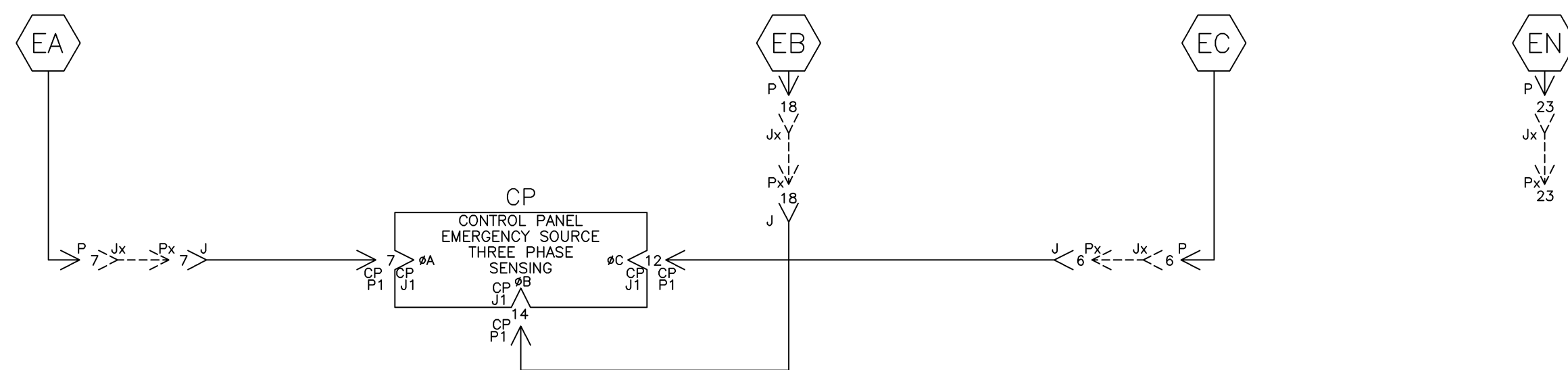

LOAD TERMINAL CIRCUITS

LOAD



NORMAL SOURCE CIRCUITS

NORMAL

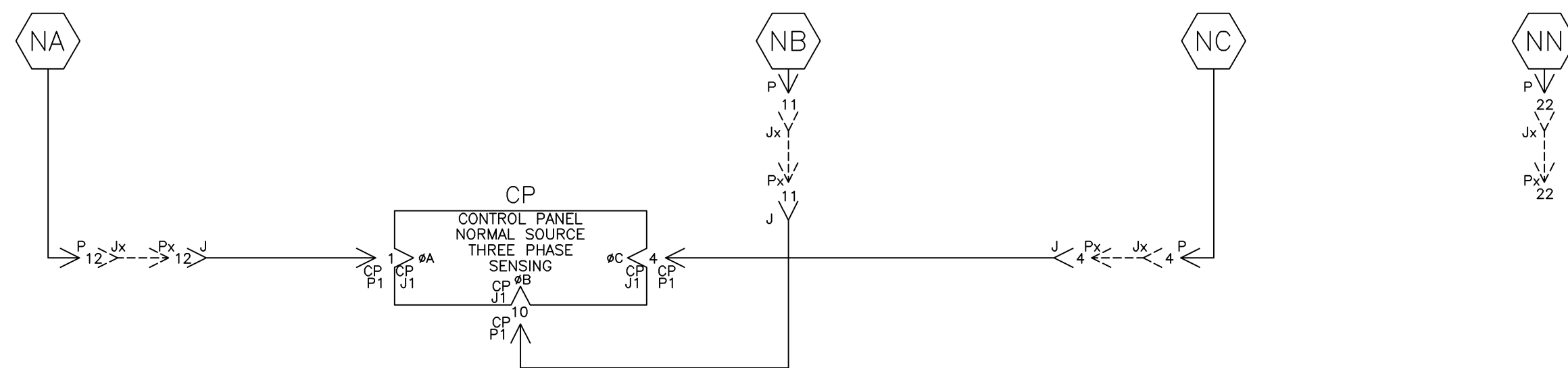

CONTROL CIRCUITS

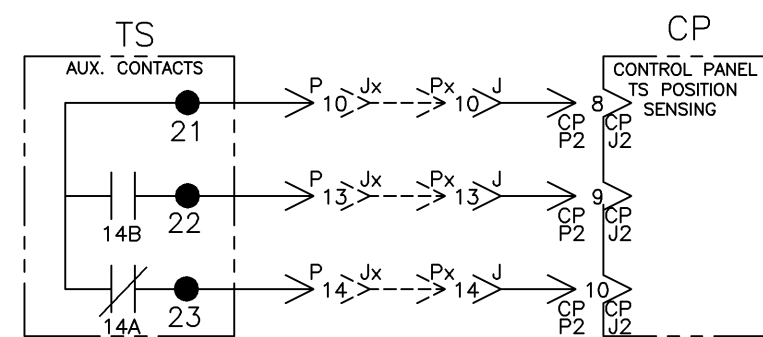

B	205832	JPB	JPB	9/8/05
SEE ECN				
A	205582	JPB	JPB	8/18/05
SEE ECN				
-	205265	JPB	JPB	7/26/05
ISSUE				

PROJECT NAME:		WIRING DIAGRAM		THIRD ANGLE PROJECTION	
4000 SERIES (J4ATS/J4NTS)		GROUP 5 CONTROLS		COMPUTER GENERATED DRAWING	
BY	DATE	MANUFACTURING TOLERANCES TO BE IN ACCORDANCE WITH ASCO PROCEDURE MP-I-003. FOR PLASTIC PARTS SEE MP-I-055		ASSEM. REF. NO.	
JPB	7/26/05	PROPERTY OF ASCO POWER TECHNOLOGIES. USE PERMITTED FOR OUR WORK ONLY. ALL RIGHTS OF DESIGN OR INVENTION ARE RESERVED.		SCALE 1:1 ACAD FILE	
CHECKED	DATE	PROPERTY OF ASCO POWER TECHNOLOGIES. USE PERMITTED FOR OUR WORK ONLY. ALL RIGHTS OF DESIGN OR INVENTION ARE RESERVED.		SIZE DWG. NO.	
JPB	7/26/05	ASCO POWER TECHNOLOGIES, L.P. FLORHAM PARK, NEW JERSEY 07932 U.S.A.		DS781123	
DRAWING APPROVAL		ASCO		CHANGE LETTER ECN NO. 205832 SHEET NO. 4 OF 6	

PHYSICAL DIAGRAM

ENCLOSURE

DOOR (INSIDE)

TS (TRANSFER SWITCH)  
VIEW FROM INSIDE FRONT

OPTIONAL  
POWERMANAGER  
OR ADDITIONAL  
OPERATOR CONTROLS  
ESCUTCHEON MOUNTING

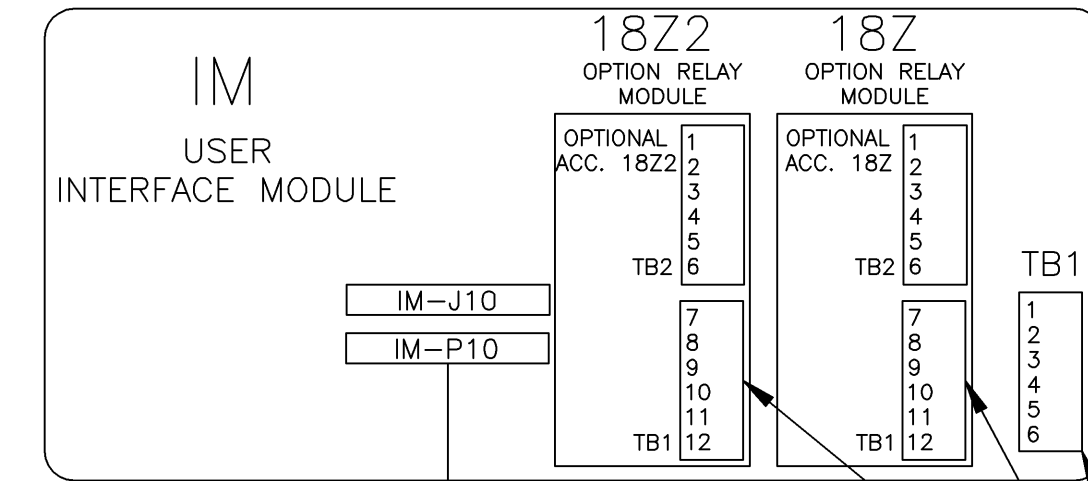

IM/CP  
HARNESS  
BASE PN 766102  
(REFER TO BILL  
OF MATERIAL)

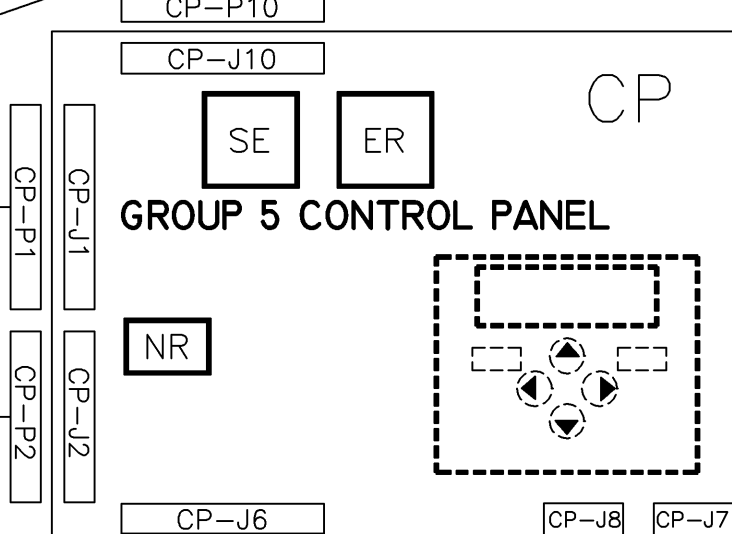

USER INTERFACE  
MODULE FIELD  
TERMINATIONS  
ACC. 18Z & 18Z2  
FIELD  
TERMINATIONS

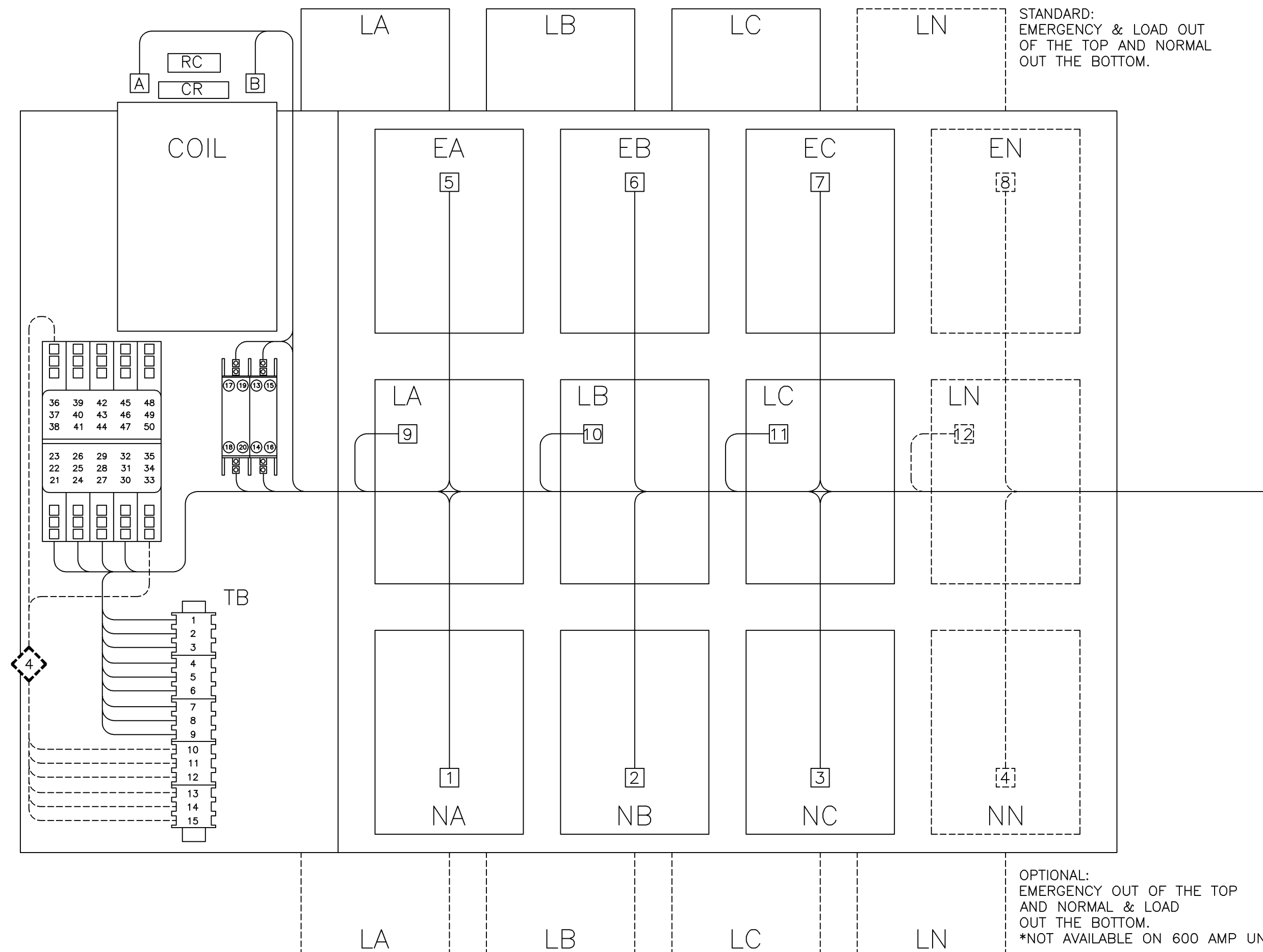
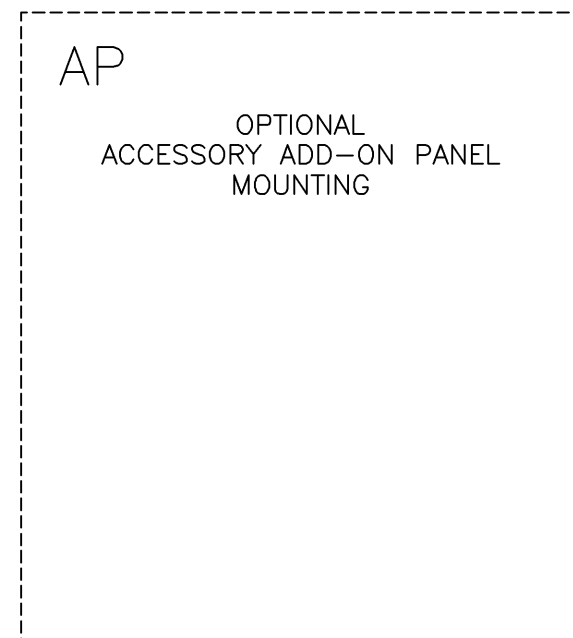

DOOR HINGE

BONDING STRAP  
PN 098323-019

B	205832	JPB	JPB	9/8/05
A	205582	JPB	JPB	8/18/05
-	205265	JPB	JPB	7/26/05
				ISSUE

PROJECT NAME:		WIRING DIAGRAM		THIRD ANGLE PROJECTION	
4000 SERIES (J4ATS/J4NTS)		GROUP 5 CONTROLS		COMPUTER GENERATED DRAWING	
BY	DATE	MANUFACTURING TOLERANCES TO BE IN ACCORDANCE WITH ASCO PROCEDURE MP-1-003. FOR PLASTIC PARTS SEE MP-1-005.		ASSEM. REF. NO.	
CHECKED	7/26/05	PROPERTY OF ASCO POWER TECHNOLOGIES. USE PERMITTED FOR OUR WORK ONLY. ALL RIGHTS OF DESIGN OR INVENTION ARE RESERVED.		SCALE 1:1 ACAD FILE	
DRAFTING APPROVAL		ASCO		SIZE DWG. NO. DS781123	
FINAL APPROVAL	7/26/05	ASC POWER TECHNOLOGIES, L.P. FLORHAM PARK, NEW JERSEY 07932 U.S.A.		CHANGE LETTER ECN NO. 205832 SHEET 5 OF 6	

