

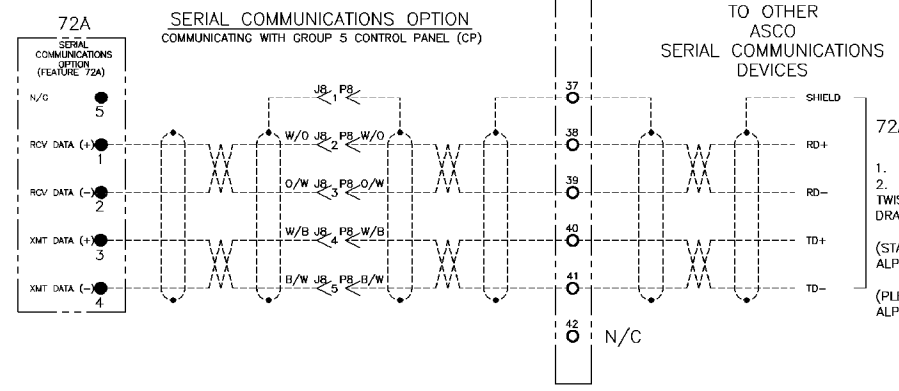

# FIELD CONNECTIONS

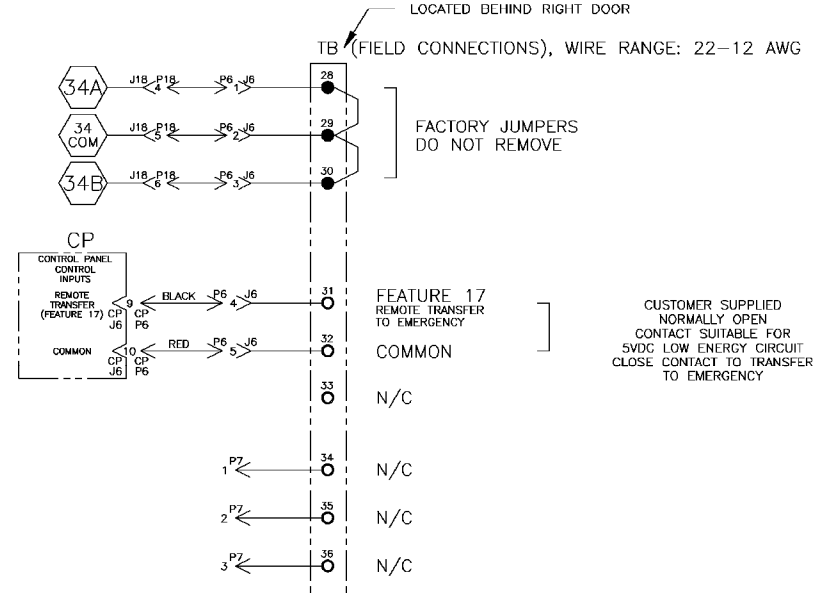

- 72A NOTES:
- GROUND SHIELD AT HOST DEVICE ONLY.
  - FIELD WIRING: USE UL LISTED, STRANDED, TWISTED PAIRS, OVERALL FOIL SHIELD WITH STRANDED DRAIN WIRE SUITABLE FOR RS-422 EQUIVALENT TO: (STANDARD 80°C) BELDEN 9842 OR 9829 OR ALPHA 6202C OR 6222C (PLENUM RATED) BELDEN 89729 OR 82729 OR ALPHA 58902

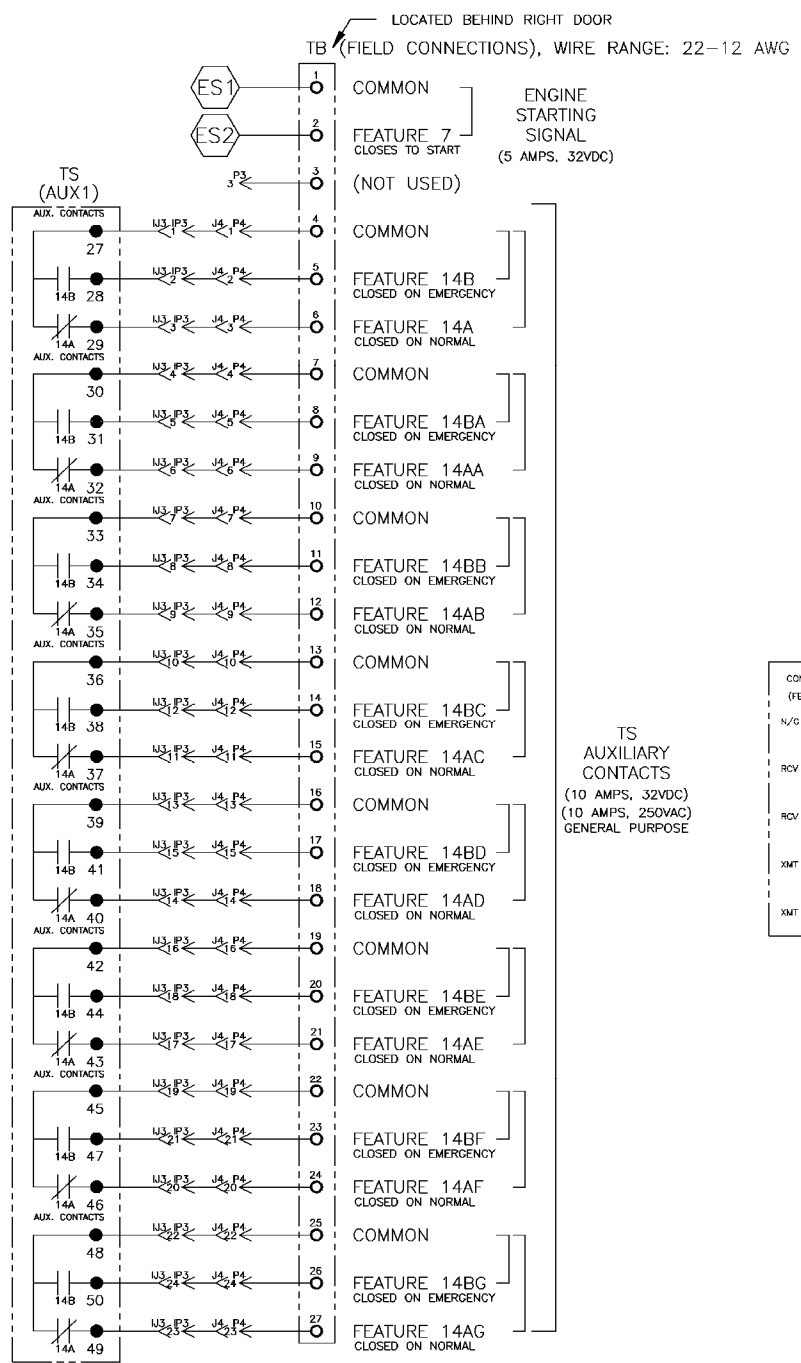
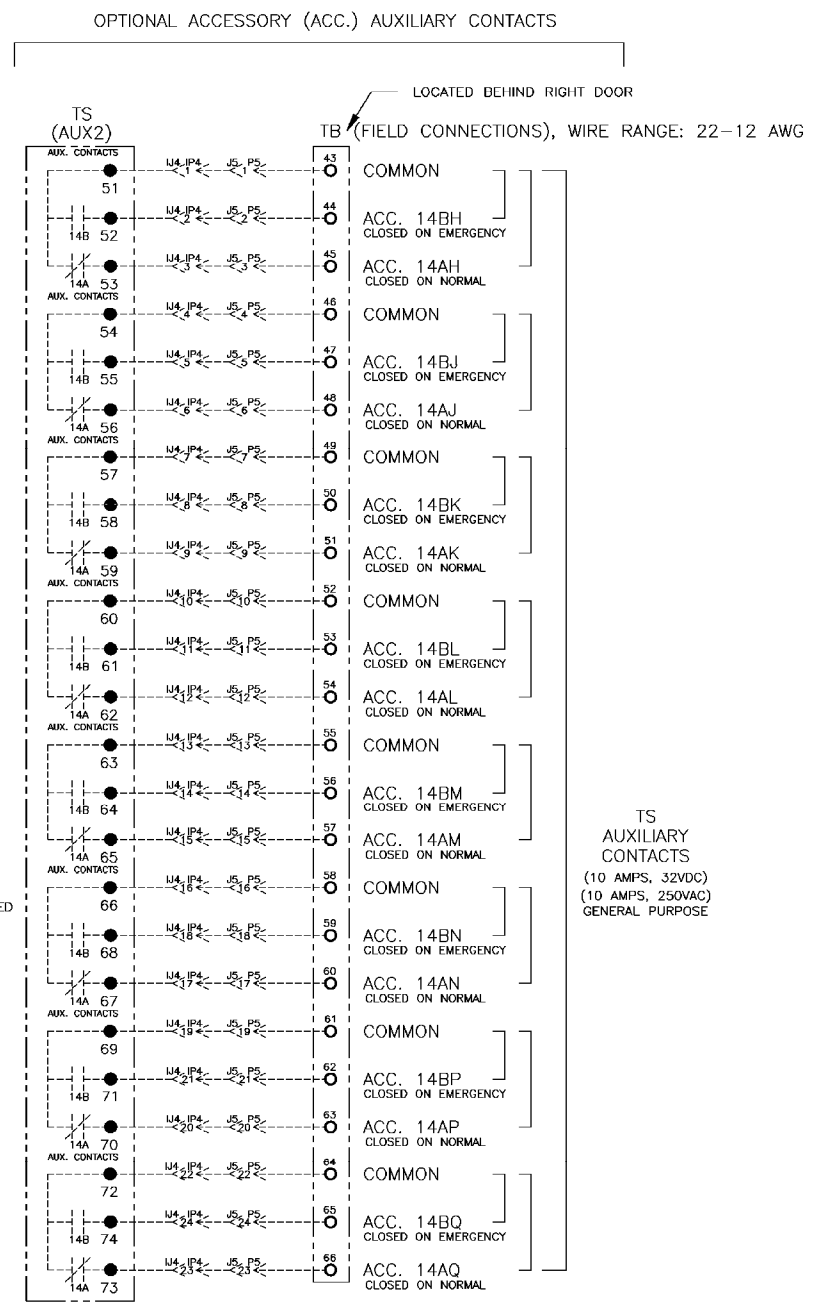

TS AUXILIARY CONTACTS  
(10 AMPS, 32VDC)  
(10 AMPS, 250VAC)  
GENERAL PURPOSE

TS AUXILIARY CONTACTS  
(10 AMPS, 32VDC)  
(10 AMPS, 250VAC)  
GENERAL PURPOSE

PROJECT NAME		157978 WK BK 6/15/01	
WIRING DIAGRAM		SEE ECN	
7000 SERIES (7ATB) GROUP 5 CONTROLS		SUBSIDIARY DISTRIBUTION	
THIRD ANGLE PROJECTION		<input type="checkbox"/> AN <input type="checkbox"/> AW <input type="checkbox"/> AS <input type="checkbox"/> AL <input type="checkbox"/> AR <input type="checkbox"/> AP <input type="checkbox"/> AC <input type="checkbox"/> AS <input type="checkbox"/> AS	
DRAWN BY JPB DATE 2/98		MANUFACTURING TOLERANCES TO BE IN ACCORDANCE WITH ASCO PROCEDURE MP-1-003. FOR PLASTIC PARTS SEE MP-1-055.	
CHECKED		PROPERTY OF ASCO POWER TECHNOLOGIES. USE PERMITTED FOR OUR WORK ONLY. ALL RIGHTS OF DESIGN OR INVENTION ARE RESERVED.	
DRAFTING APPROVAL SDH 2/98		ASCO POWER TECHNOLOGIES, L.P. FLOHAM PARK, NEW JERSEY 07932 U.S.A.	
FINAL APPROVAL		SCALE: DWG. NO. DS1617421	
		CHANGE LETTER E SON NO. 157978 SHEET 2 OF 8	

NORMAL SOURCE CIRCUITS

NORMAL

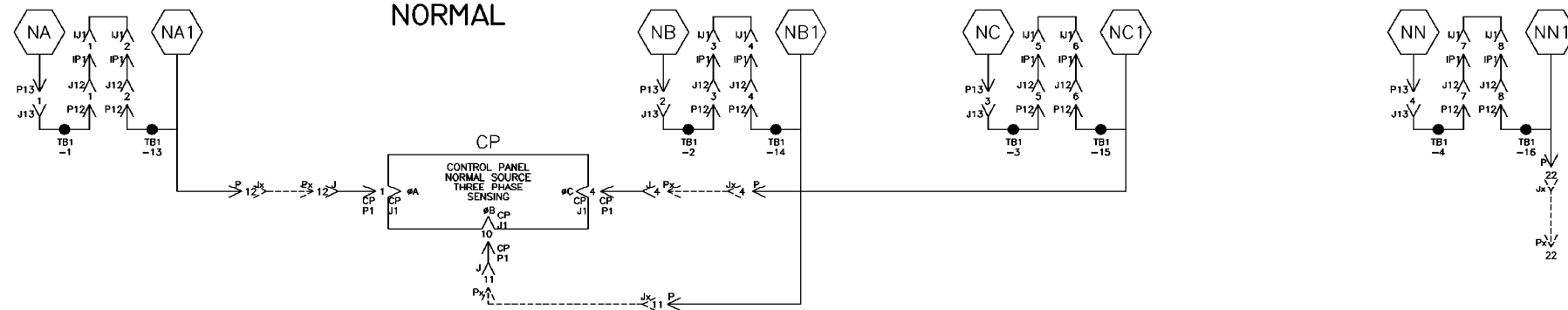

EMERGENCY SOURCE CIRCUITS

EMERGENCY

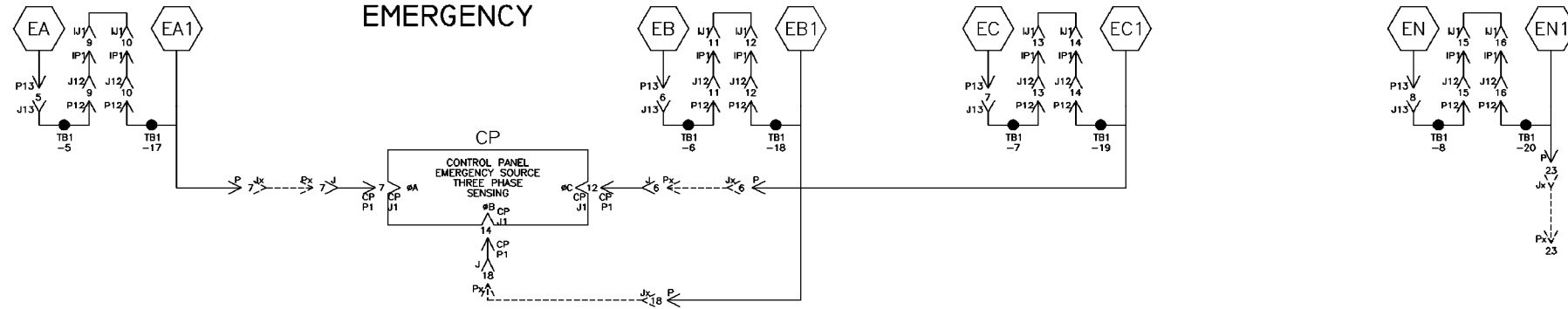

LOAD TERMINAL CIRCUITS

LOAD

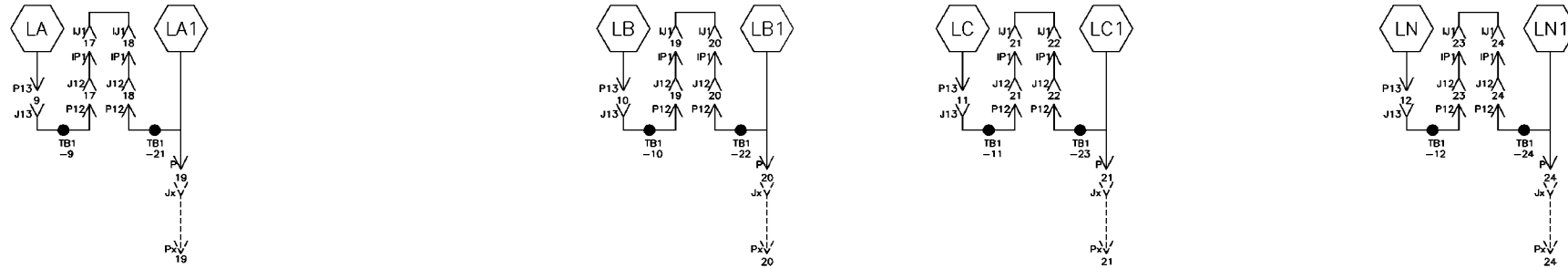

CONTROL SIGNALS & INDICATION

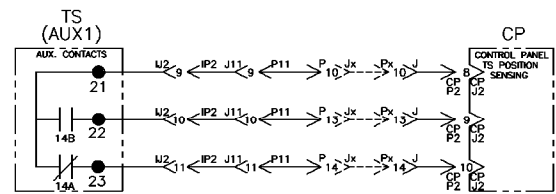

ENGINE START CIRCUIT

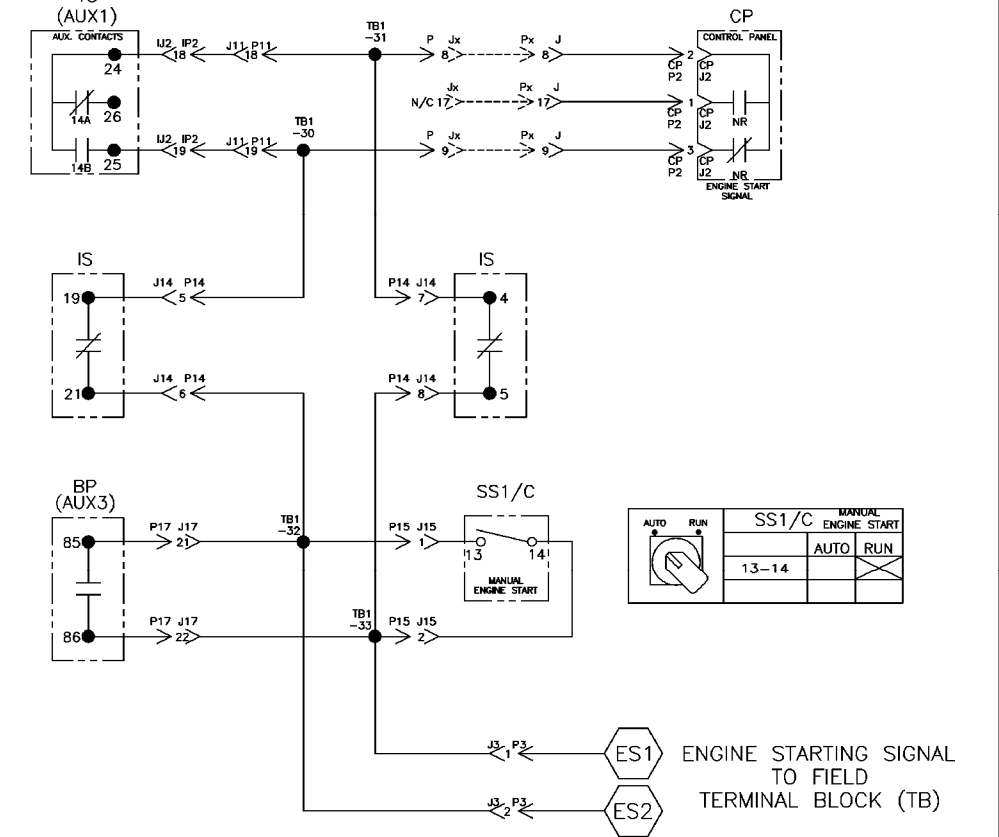

CONTROL PANEL/BYPASS-ISOLATION INTERLOCKS

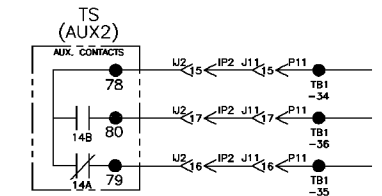
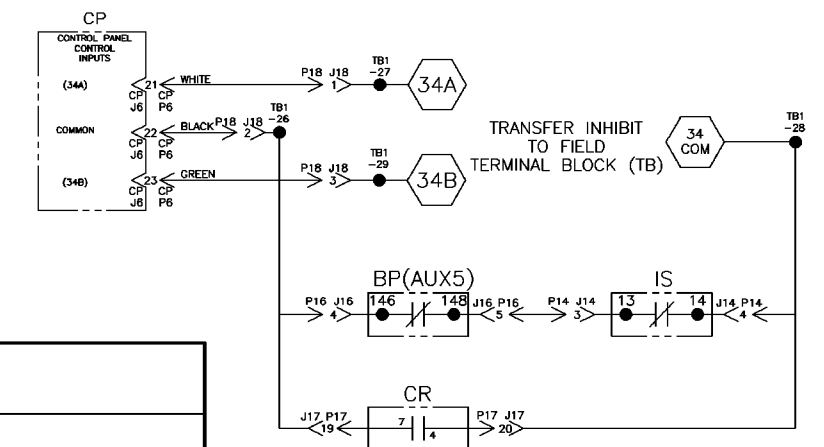

SPARE FOR FACTORY USE

PROJECT NAME:		E 157978 WK BK 6/15/01	
WIRING DIAGRAM		SEE ECN	
7000 SERIES (7ATB)		SUBSIDIARY DISTRIBUTION	
GROUP 5 CONTROLS		<input type="checkbox"/> AN <input type="checkbox"/> AW <input type="checkbox"/> AX <input type="checkbox"/> AL <input type="checkbox"/> AR <input type="checkbox"/> AS <input type="checkbox"/> AT <input type="checkbox"/> AU <input type="checkbox"/> AV <input type="checkbox"/> AW <input type="checkbox"/> AX <input type="checkbox"/> AY <input type="checkbox"/> AZ <input type="checkbox"/> BA <input type="checkbox"/> BB <input type="checkbox"/> BC <input type="checkbox"/> BD <input type="checkbox"/> BE <input type="checkbox"/> BF <input type="checkbox"/> BG <input type="checkbox"/> BH <input type="checkbox"/> BI <input type="checkbox"/> BJ <input type="checkbox"/> BK <input type="checkbox"/> BL <input type="checkbox"/> BM <input type="checkbox"/> BN <input type="checkbox"/> BO <input type="checkbox"/> BP <input type="checkbox"/> BQ <input type="checkbox"/> BR <input type="checkbox"/> BS <input type="checkbox"/> BT <input type="checkbox"/> BU <input type="checkbox"/> BV <input type="checkbox"/> BW <input type="checkbox"/> BX <input type="checkbox"/> BY <input type="checkbox"/> BZ <input type="checkbox"/> CA <input type="checkbox"/> CB <input type="checkbox"/> CC <input type="checkbox"/> CD <input type="checkbox"/> CE <input type="checkbox"/> CF <input type="checkbox"/> CG <input type="checkbox"/> CH <input type="checkbox"/> CI <input type="checkbox"/> CJ <input type="checkbox"/> CK <input type="checkbox"/> CL <input type="checkbox"/> CM <input type="checkbox"/> CN <input type="checkbox"/> CO <input type="checkbox"/> CP <input type="checkbox"/> CQ <input type="checkbox"/> CR <input type="checkbox"/> CS <input type="checkbox"/> CT <input type="checkbox"/> CU <input type="checkbox"/> CV <input type="checkbox"/> CW <input type="checkbox"/> CX <input type="checkbox"/> CY <input type="checkbox"/> CZ <input type="checkbox"/> DA <input type="checkbox"/> DB <input type="checkbox"/> DC <input type="checkbox"/> DD <input type="checkbox"/> DE <input type="checkbox"/> DF <input type="checkbox"/> DG <input type="checkbox"/> DH <input type="checkbox"/> DI <input type="checkbox"/> DJ <input type="checkbox"/> DK <input type="checkbox"/> DL <input type="checkbox"/> DM <input type="checkbox"/> DN <input type="checkbox"/> DO <input type="checkbox"/> DP <input type="checkbox"/> DQ <input type="checkbox"/> DR <input type="checkbox"/> DS <input type="checkbox"/> DT <input type="checkbox"/> DU <input type="checkbox"/> DV <input type="checkbox"/> DW <input type="checkbox"/> DX <input type="checkbox"/> DY <input type="checkbox"/> DZ <input type="checkbox"/> EA <input type="checkbox"/> EB <input type="checkbox"/> EC <input type="checkbox"/> ED <input type="checkbox"/> EE <input type="checkbox"/> EF <input type="checkbox"/> EG <input type="checkbox"/> EH <input type="checkbox"/> EI <input type="checkbox"/> EJ <input type="checkbox"/> EK <input type="checkbox"/> EL <input type="checkbox"/> EM <input type="checkbox"/> EN <input type="checkbox"/> EO <input type="checkbox"/> EP <input type="checkbox"/> EQ <input type="checkbox"/> ER <input type="checkbox"/> ES <input type="checkbox"/> ET <input type="checkbox"/> EU <input type="checkbox"/> EV <input type="checkbox"/> EW <input type="checkbox"/> EX <input type="checkbox"/> EY <input type="checkbox"/> EZ <input type="checkbox"/> FA <input type="checkbox"/> FB <input type="checkbox"/> FC <input type="checkbox"/> FD <input type="checkbox"/> FE <input type="checkbox"/> FF <input type="checkbox"/> FG <input type="checkbox"/> FH <input type="checkbox"/> FI <input type="checkbox"/> FJ <input type="checkbox"/> FK <input type="checkbox"/> FL <input type="checkbox"/> FM <input type="checkbox"/> FN <input type="checkbox"/> FO <input type="checkbox"/> FP <input type="checkbox"/> FQ <input type="checkbox"/> FR <input type="checkbox"/> FS <input type="checkbox"/> FT <input type="checkbox"/> FU <input type="checkbox"/> FV <input type="checkbox"/> FW <input type="checkbox"/> FX <input type="checkbox"/> FY <input type="checkbox"/> FZ <input type="checkbox"/> GA <input type="checkbox"/> GB <input type="checkbox"/> GC <input type="checkbox"/> GD <input type="checkbox"/> GE <input type="checkbox"/> GF <input type="checkbox"/> GG <input type="checkbox"/> GH <input type="checkbox"/> GI <input type="checkbox"/> GJ <input type="checkbox"/> GK <input type="checkbox"/> GL <input type="checkbox"/> GM <input type="checkbox"/> GN <input type="checkbox"/> GO <input type="checkbox"/> GP <input type="checkbox"/> GQ <input type="checkbox"/> GR <input type="checkbox"/> GS <input type="checkbox"/> GT <input type="checkbox"/> GU <input type="checkbox"/> GV <input type="checkbox"/> GW <input type="checkbox"/> GX <input type="checkbox"/> GY <input type="checkbox"/> GZ <input type="checkbox"/> HA <input type="checkbox"/> HB <input type="checkbox"/> HC <input type="checkbox"/> HD <input type="checkbox"/> HE <input type="checkbox"/> HF <input type="checkbox"/> HG <input type="checkbox"/> HH <input type="checkbox"/> HI <input type="checkbox"/> HJ <input type="checkbox"/> HK <input type="checkbox"/> HL <input type="checkbox"/> HM <input type="checkbox"/> HN <input type="checkbox"/> HO <input type="checkbox"/> HP <input type="checkbox"/> HQ <input type="checkbox"/> HR <input type="checkbox"/> HS <input type="checkbox"/> HT <input type="checkbox"/> HU <input type="checkbox"/> HV <input type="checkbox"/> HW <input type="checkbox"/> HX <input type="checkbox"/> HY <input type="checkbox"/> HZ <input type="checkbox"/> IA <input type="checkbox"/> IB <input type="checkbox"/> IC <input type="checkbox"/> ID <input type="checkbox"/> IE <input type="checkbox"/> IF <input type="checkbox"/> IG <input type="checkbox"/> IH <input type="checkbox"/> II <input type="checkbox"/> IJ <input type="checkbox"/> IK <input type="checkbox"/> IL <input type="checkbox"/> IM <input type="checkbox"/> IN <input type="checkbox"/> IO <input type="checkbox"/> IP <input type="checkbox"/> IQ <input type="checkbox"/> IR <input type="checkbox"/> IS <input type="checkbox"/> IT <input type="checkbox"/> IU <input type="checkbox"/> IV <input type="checkbox"/> IW <input type="checkbox"/> IX <input type="checkbox"/> IY <input type="checkbox"/> IZ <input type="checkbox"/> JA <input type="checkbox"/> JB <input type="checkbox"/> JC <input type="checkbox"/> JD <input type="checkbox"/> JE <input type="checkbox"/> JF <input type="checkbox"/> JG <input type="checkbox"/> JH <input type="checkbox"/> JI <input type="checkbox"/> JJ <input type="checkbox"/> JK <input type="checkbox"/> JL <input type="checkbox"/> JM <input type="checkbox"/> JN <input type="checkbox"/> JO <input type="checkbox"/> JP <input type="checkbox"/> JQ <input type="checkbox"/> JR <input type="checkbox"/> JS <input type="checkbox"/> JT <input type="checkbox"/> JU <input type="checkbox"/> JV <input type="checkbox"/> JW <input type="checkbox"/> JX <input type="checkbox"/> JY <input type="checkbox"/> JZ <input type="checkbox"/> KA <input type="checkbox"/> KB <input type="checkbox"/> KC <input type="checkbox"/> KD <input type="checkbox"/> KE <input type="checkbox"/> KF <input type="checkbox"/> KG <input type="checkbox"/> KH <input type="checkbox"/> KI <input type="checkbox"/> KJ <input type="checkbox"/> KK <input type="checkbox"/> KL <input type="checkbox"/> KM <input type="checkbox"/> KN <input type="checkbox"/> KO <input type="checkbox"/> KP <input type="checkbox"/> KQ <input type="checkbox"/> KR <input type="checkbox"/> KS <input type="checkbox"/> KT <input type="checkbox"/> KU <input type="checkbox"/> KV <input type="checkbox"/> KW <input type="checkbox"/> KX <input type="checkbox"/> KY <input type="checkbox"/> KZ <input type="checkbox"/> LA <input type="checkbox"/> LB <input type="checkbox"/> LC <input type="checkbox"/> LD <input type="checkbox"/> LE <input type="checkbox"/> LF <input type="checkbox"/> LG <input type="checkbox"/> LH <input type="checkbox"/> LI <input type="checkbox"/> LJ <input type="checkbox"/> LK <input type="checkbox"/> LL <input type="checkbox"/> LM <input type="checkbox"/> LN <input type="checkbox"/> LO <input type="checkbox"/> LP <input type="checkbox"/> LQ <input type="checkbox"/> LR <input type="checkbox"/> LS <input type="checkbox"/> LT <input type="checkbox"/> LU <input type="checkbox"/> LV <input type="checkbox"/> LW <input type="checkbox"/> LX <input type="checkbox"/> LY <input type="checkbox"/> LZ <input type="checkbox"/> MA <input type="checkbox"/> MB <input type="checkbox"/> MC <input type="checkbox"/> MD <input type="checkbox"/> ME <input type="checkbox"/> MF <input type="checkbox"/> MG <input type="checkbox"/> MH <input type="checkbox"/> MI <input type="checkbox"/> MJ <input type="checkbox"/> MK <input type="checkbox"/> ML <input type="checkbox"/> MN <input type="checkbox"/> MO <input type="checkbox"/> MP <input type="checkbox"/> MQ <input type="checkbox"/> MR <input type="checkbox"/> MS <input type="checkbox"/> MT <input type="checkbox"/> MU <input type="checkbox"/> MV <input type="checkbox"/> MW <input type="checkbox"/> MX <input type="checkbox"/> MY <input type="checkbox"/> MZ <input type="checkbox"/> NA <input type="checkbox"/> NB <input type="checkbox"/> NC <input type="checkbox"/> ND <input type="checkbox"/> NE <input type="checkbox"/> NF <input type="checkbox"/> NG <input type="checkbox"/> NH <input type="checkbox"/> NI <input type="checkbox"/> NJ <input type="checkbox"/> NK <input type="checkbox"/> NL <input type="checkbox"/> NO <input type="checkbox"/> NP <input type="checkbox"/> NQ <input type="checkbox"/> NR <input type="checkbox"/> NS <input type="checkbox"/> NT <input type="checkbox"/> NU <input type="checkbox"/> NV <input type="checkbox"/> NW <input type="checkbox"/> NX <input type="checkbox"/> NY <input type="checkbox"/> NZ <input type="checkbox"/> OA <input type="checkbox"/> OB <input type="checkbox"/> OC <input type="checkbox"/> OD <input type="checkbox"/> OE <input type="checkbox"/> OF <input type="checkbox"/> OG <input type="checkbox"/> OH <input type="checkbox"/> OI <input type="checkbox"/> OJ <input type="checkbox"/> OK <input type="checkbox"/> OL <input type="checkbox"/> OM <input type="checkbox"/> ON <input type="checkbox"/> OO <input type="checkbox"/> OP <input type="checkbox"/> OQ <input type="checkbox"/> OR <input type="checkbox"/> OS <input type="checkbox"/> OT <input type="checkbox"/> OU <input type="checkbox"/> OV <input type="checkbox"/> OW <input type="checkbox"/> OX <input type="checkbox"/> OY <input type="checkbox"/> OZ <input type="checkbox"/> PA <input type="checkbox"/> PB <input type="checkbox"/> PC <input type="checkbox"/> PD <input type="checkbox"/> PE <input type="checkbox"/> PF <input type="checkbox"/> PG <input type="checkbox"/> PH <input type="checkbox"/> PI <input type="checkbox"/> PJ <input type="checkbox"/> PK <input type="checkbox"/> PL <input type="checkbox"/> PM <input type="checkbox"/> PN <input type="checkbox"/> PO <input type="checkbox"/> PP <input type="checkbox"/> PQ <input type="checkbox"/> PR <input type="checkbox"/> PS <input type="checkbox"/> PT <input type="checkbox"/> PU <input type="checkbox"/> PV <input type="checkbox"/> PW <input type="checkbox"/> PX <input type="checkbox"/> PY <input type="checkbox"/> PZ <input type="checkbox"/> QA <input type="checkbox"/> QB <input type="checkbox"/> QC <input type="checkbox"/> QD <input type="checkbox"/> QE <input type="checkbox"/> QF <input type="checkbox"/> QG <input type="checkbox"/> QH <input type="checkbox"/> QI <input type="checkbox"/> QJ <input type="checkbox"/> QK <input type="checkbox"/> QL <input type="checkbox"/> QM <input type="checkbox"/> QN <input type="checkbox"/> QO <input type="checkbox"/> QP <input type="checkbox"/> QQ <input type="checkbox"/> QR <input type="checkbox"/> QS <input type="checkbox"/> QT <input type="checkbox"/> QU <input type="checkbox"/> QV <input type="checkbox"/> QW <input type="checkbox"/> QX <input type="checkbox"/> QY <input type="checkbox"/> QZ <input type="checkbox"/> RA <input type="checkbox"/> RB <input type="checkbox"/> RC <input type="checkbox"/> RD <input type="checkbox"/> RE <input type="checkbox"/> RF <input type="checkbox"/> RG <input type="checkbox"/> RH <input type="checkbox"/> RI <input type="checkbox"/> RJ <input type="checkbox"/> RK <input type="checkbox"/> RL <input type="checkbox"/> RM <input type="checkbox"/> RN <input type="checkbox"/> RO <input type="checkbox"/> RP <input type="checkbox"/> RQ <input type="checkbox"/> RR <input type="checkbox"/> RS <input type="checkbox"/> RT <input type="checkbox"/> RU <input type="checkbox"/> RV <input type="checkbox"/> RW <input type="checkbox"/> RX <input type="checkbox"/> RY <input type="checkbox"/> RZ <input type="checkbox"/> SA <input type="checkbox"/> SB <input type="checkbox"/> SC <input type="checkbox"/> SD <input type="checkbox"/> SE <input type="checkbox"/> SF <input type="checkbox"/> SG <input type="checkbox"/> SH <input type="checkbox"/> SI <input type="checkbox"/> SJ <input type="checkbox"/> SK <input type="checkbox"/> SL <input type="checkbox"/> SM <input type="checkbox"/> SN <input type="checkbox"/> SO <input type="checkbox"/> SP <input type="checkbox"/> SQ <input type="checkbox"/> SR <input type="checkbox"/> SS <input type="checkbox"/> ST <input type="checkbox"/> SU <input type="checkbox"/> SV <input type="checkbox"/> SW <input type="checkbox"/> SX <input type="checkbox"/> SY <input type="checkbox"/> SZ <input type="checkbox"/> TA <input type="checkbox"/> TB <input type="checkbox"/> TC <input type="checkbox"/> TD <input type="checkbox"/> TE <input type="checkbox"/> TF <input type="checkbox"/> TG <input type="checkbox"/> TH <input type="checkbox"/> TI <input type="checkbox"/> TJ <input type="checkbox"/> TK <input type="checkbox"/> TL <input type="checkbox"/> TM <input type="checkbox"/> TN <input type="checkbox"/> TO <input type="checkbox"/> TP <input type="checkbox"/> TQ <input type="checkbox"/> TR <input type="checkbox"/> TS <input type="checkbox"/> TU <input type="checkbox"/> TV <input type="checkbox"/> TW <input type="checkbox"/> TX <input type="checkbox"/> TY <input type="checkbox"/> TZ <input type="checkbox"/> UA <input type="checkbox"/> UB <input type="checkbox"/> UC <input type="checkbox"/> UD <input type="checkbox"/> UE <input type="checkbox"/> UF <input type="checkbox"/> UG <input type="checkbox"/> UH <input type="checkbox"/> UI <input type="checkbox"/> UJ <input type="checkbox"/> UK <input type="checkbox"/> UL <input type="checkbox"/> UM <input type="checkbox"/> UN <input type="checkbox"/> UO <input type="checkbox"/> UP <input type="checkbox"/> UQ <input type="checkbox"/> UR <input type="checkbox"/> US <input type="checkbox"/> UT <input type="checkbox"/> UY <input type="checkbox"/> UV <input type="checkbox"/> UW <input type="checkbox"/> UX <input type="checkbox"/> UZ <input type="checkbox"/> VA <input type="checkbox"/> VB <input type="checkbox"/> VC <input type="checkbox"/> VD <input type="checkbox"/> VE <input type="checkbox"/> VF <input type="checkbox"/> VG <input type="checkbox"/> VH <input type="checkbox"/> VI <input type="checkbox"/> VJ <input type="checkbox"/> VK <input type="checkbox"/> VL <input type="checkbox"/> VM <input type="checkbox"/> VN <input type="checkbox"/> VO <input type="checkbox"/> VP <input type="checkbox"/> VQ <input type="checkbox"/> VR <input type="checkbox"/> VS <input type="checkbox"/> VT <input type="checkbox"/> VU <input type="checkbox"/> VV <input type="checkbox"/> VW <input type="checkbox"/> VX <input type="checkbox"/> VY <input type="checkbox"/> VZ <input type="checkbox"/> WA <input type="checkbox"/> WB <input type="checkbox"/> WC <input type="checkbox"/> WD <input type="checkbox"/> WE <input type="checkbox"/> WF <input type="checkbox"/> WG <input type="checkbox"/> WH <input type="checkbox"/> WI <input type="checkbox"/> WJ <input type="checkbox"/> WK <input type="checkbox"/> WL <input type="checkbox"/> WM <input type="checkbox"/> WN <input type="checkbox"/> WO <input type="checkbox"/> WP <input type="checkbox"/> WQ <input type="checkbox"/> WR <input type="checkbox"/> WS <input type="checkbox"/> WT <input type="checkbox"/> WU <input type="checkbox"/> WV <input type="checkbox"/> WW <input type="checkbox"/> WX <input type="checkbox"/> WY <input type="checkbox"/> WZ <input type="checkbox"/> XA <input type="checkbox"/> XB <input type="checkbox"/> XC <input type="checkbox"/> XD <input type="checkbox"/> XE <input type="checkbox"/> XF <input type="checkbox"/> XG <input type="checkbox"/> XH <input type="checkbox"/> XI <input type="checkbox"/> XJ <input type="checkbox"/> XK <input type="checkbox"/> XL <input type="checkbox"/> XM <input type="checkbox"/> XN <input type="checkbox"/> XO <input type="checkbox"/> XP <input type="checkbox"/> XQ <input type="checkbox"/> XR <input type="checkbox"/> XS <input type="checkbox"/> XT <input type="checkbox"/> XU <input type="checkbox"/> XV <input type="checkbox"/> XW <input type="checkbox"/> XX <input type="checkbox"/> XY <input type="checkbox"/> XZ <input type="checkbox"/> YA <input type="checkbox"/> YB <input type="checkbox"/> YC <input type="checkbox"/> YD <input type="checkbox"/> YE <input type="checkbox"/> YF <input type="checkbox"/> YG <input type="checkbox"/> YH <input type="checkbox"/> YI <input type="checkbox"/> YJ <input type="checkbox"/> YK <input type="checkbox"/> YL <input type="checkbox"/> YM <input type="checkbox"/> YN <input type="checkbox"/> YO <input type="checkbox"/> YP <input type="checkbox"/> YQ <input type="checkbox"/> YR <input type="checkbox"/> YS <input type="checkbox"/> YT <input type="checkbox"/> YU <input type="checkbox"/> YV <input type="checkbox"/> YW <input type="checkbox"/> YX <input type="checkbox"/> YZ <input type="checkbox"/> ZA <input type="checkbox"/> ZB <input type="checkbox"/> ZC <input type="checkbox"/> ZD <input type="checkbox"/> ZE <input type="checkbox"/> ZF <input type="checkbox"/> ZG <input type="checkbox"/> ZH <input type="checkbox"/> ZI <input type="checkbox"/> ZJ <input type="checkbox"/> ZK <input type="checkbox"/> ZL <input type="checkbox"/> ZM <input type="checkbox"/> ZN <input type="checkbox"/> ZO <input type="checkbox"/> ZP <input type="checkbox"/> ZQ <input type="checkbox"/> ZR <input type="checkbox"/> ZS <input type="checkbox"/> ZT <input type="checkbox"/> ZU <input type="checkbox"/> ZV <input type="checkbox"/> ZW <input type="checkbox"/> ZX <input type="checkbox"/> ZY <input type="checkbox"/> ZZ <input type="checkbox"/>	

BY	DATE	MANUFACTURING TOLERANCES TO BE IN ACCORDANCE WITH ASQC PROCEDURE MP-1-003. FOR PLASTIC PARTS SEE MP-1-005.	ASSEM. REF. NO.
DRAWN BY	2/98	PROPERTY OF ASCO POWER TECHNOLOGIES. USE PERMITTED FOR OUR WORK ONLY. ALL RIGHTS OF DESIGN OR INVENTION ARE RESERVED.	SCALE
CHECKED			ACAD FILE
DRAFTING APPROVAL			SIZE
FINAL APPROVAL	SDH 2/98	ASCO POWER TECHNOLOGIES, L.P. FLORHAM PARK, NEW JERSEY 07932 U.S.A.	DS617421
			CHANGE LETTER E ECN NO. 157978 SHEET 4 of 8



LEFT DOOR, INSIDE (PANEL "L")

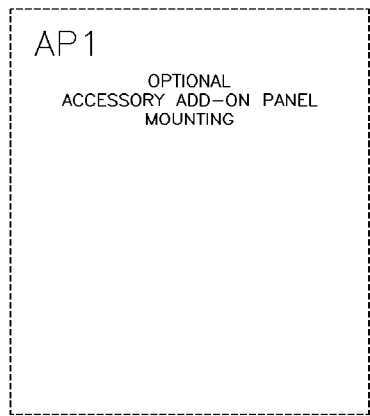
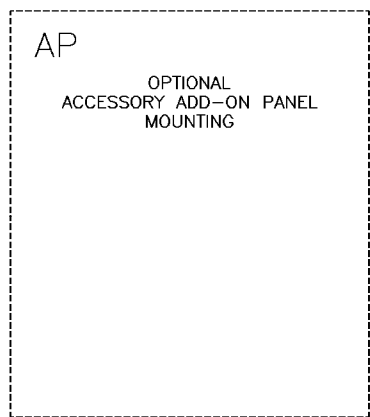
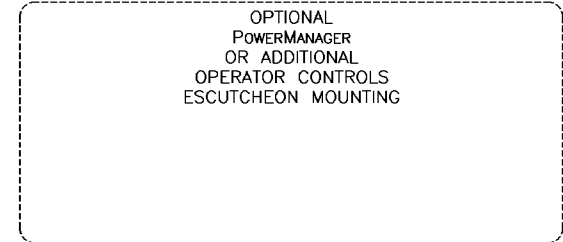

CENTER POST, INSIDE (PANEL "C")

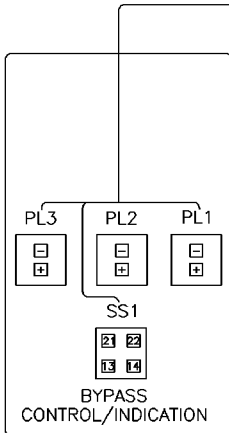

ID	DESCRIPTION
PL1	NORMAL SOURCE AVAILABLE
PL2	EMERGENCY SOURCE AVAILABLE
PL3	CONTROLS NOT IN AUTO
SS1	ENGINE START

PHYSICAL DIAGRAM

MAIN ENCLOSURE

BP (BYPASS SWITCH)

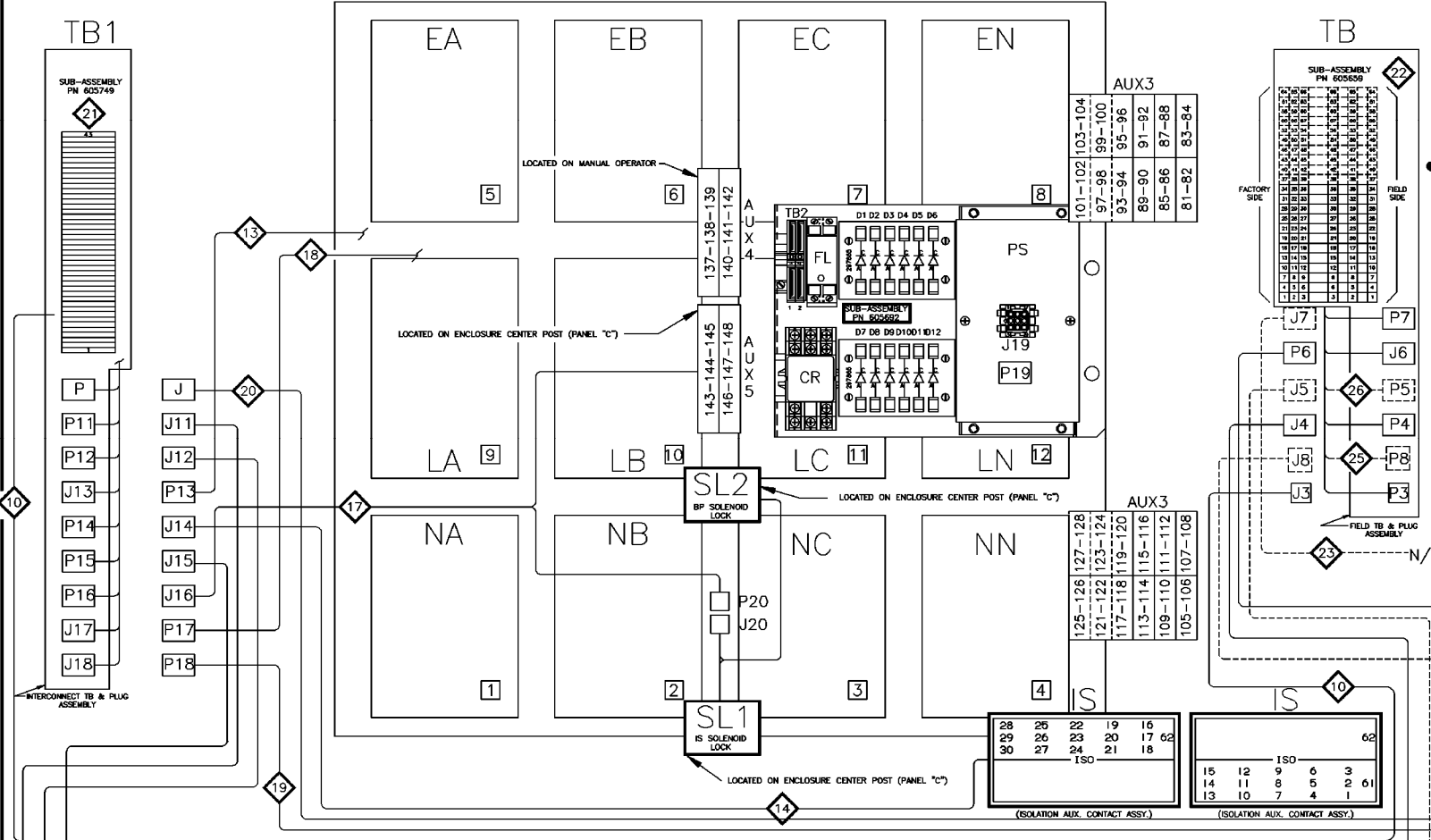

TS (TRANSFER SWITCH)

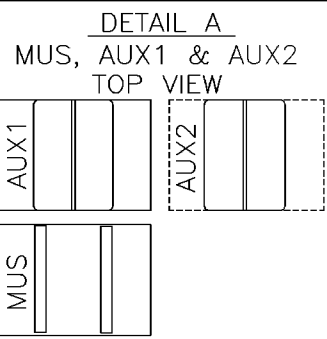
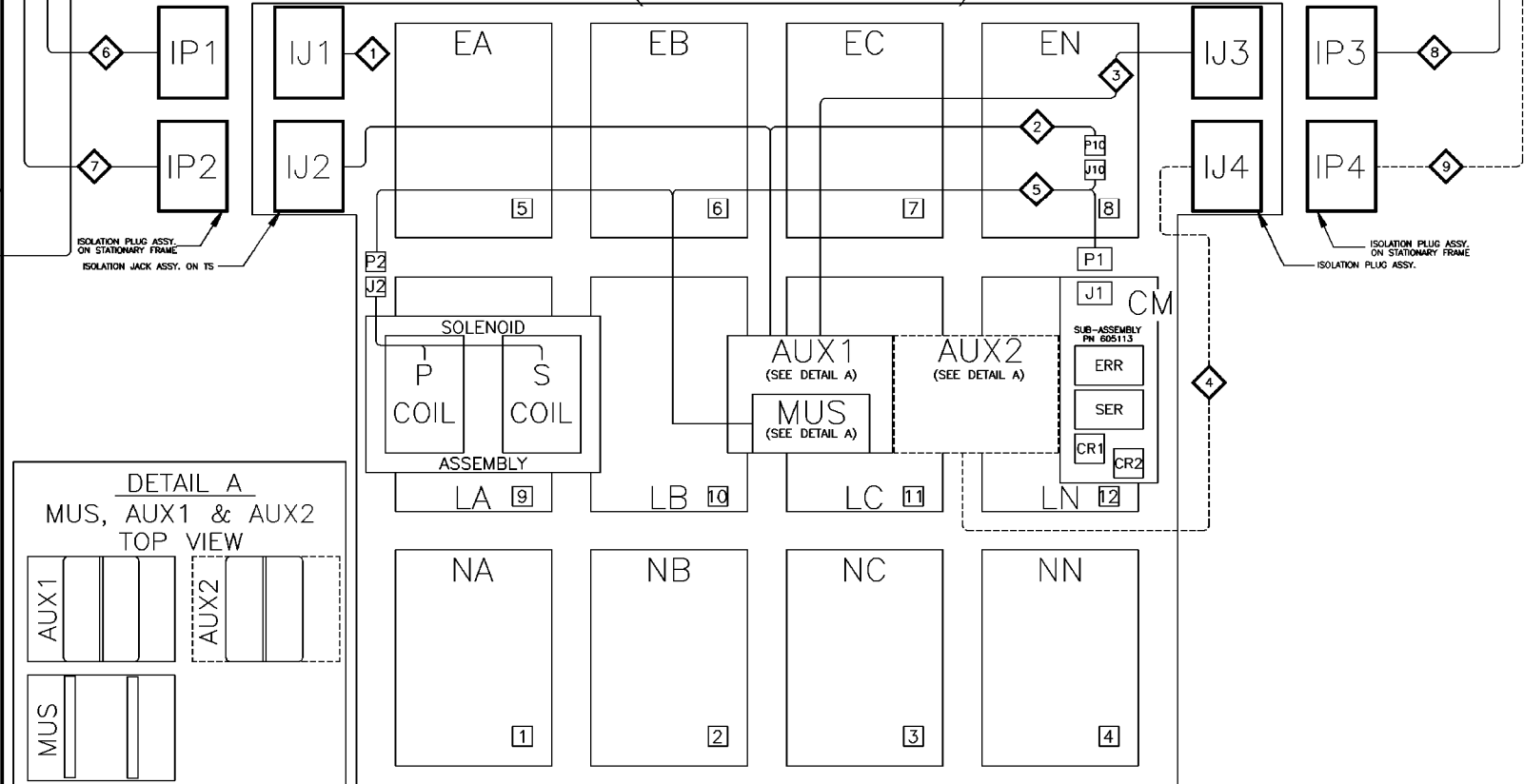

RIGHT DOOR, INSIDE (PANEL "R")

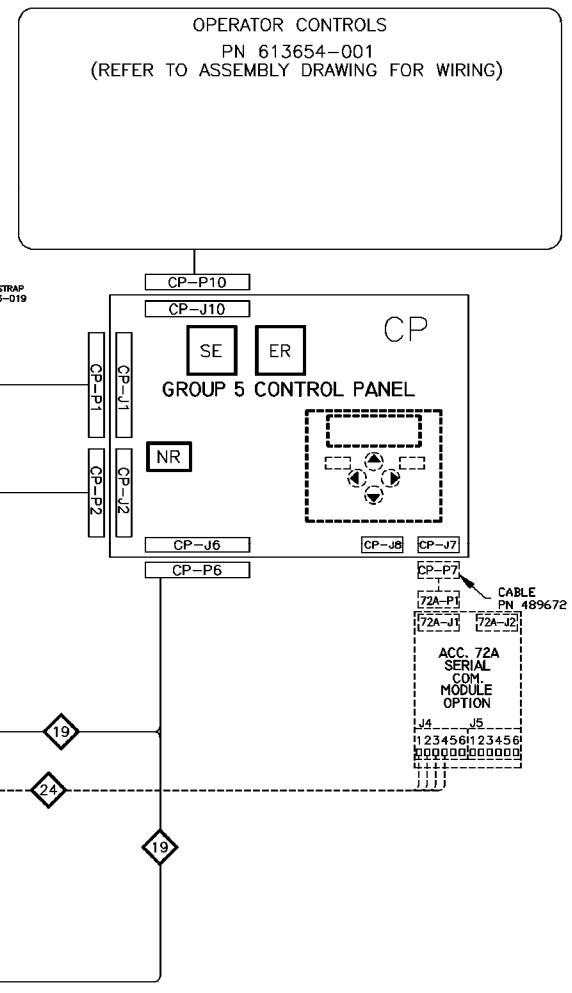

NOTE:  
ADDITIONAL OPTIONAL ACCESSORY ADD-ON PANELS MAY BE MOUNTED  
IN UPPER COMPARTMENT OF ENCLOSED TYPE UNITS. THESE ARE SHOWN  
ON THE NEXT SHEET IF APPLICABLE.

PROJECT NAME:		WIRING DIAGRAM	
DRAWN BY: JPB		DATE: 2/98	
CHECKED:		DATE:	
DRAFTING APPROVAL:		DATE:	
FINAL APPROVAL:		DATE:	
ASCO POWER TECHNOLOGIES, L.P.		FLORHAM PARK, NEW JERSEY 07932 U.S.A.	

CHANGE LETTER	ECN NO.	BY	APP.	DATE
E	157978	WK	BK	6/15/01
SEE ECN				
AC	AN	AW	AV	AL
CH	AV	AK	AS	AR
AG	AP	AC	AS	AS

SCALE	ACAD	FILE
SIZE	DWG. NO.	DS617421
CHANGE LETTER	ECN NO.	157978
SHEET 6 OF 8		

WIRE RUN LISTING

Table 1: HARNESS LOCATOR 605674-001 (J1) TS. WIRE No. 1-12, AWG 16. Includes wire numbers and harness identifiers.

Table 2: HARNESS LOCATOR 605674-002 (J2,P10) TS. WIRE No. 1-38, AWG 16. Includes wire numbers and harness identifiers.

Table 3: HARNESS LOCATOR 605674-003 (J3) TS STD. AUX. CONTACTS. WIRE No. 39-43, AWG 16. Includes wire numbers and harness identifiers.

Table 4: HARNESS LOCATOR 605674-004 (J4) TS OPT. AUX. CONTACTS. WIRE No. 40-103, AWG 16. Includes wire numbers and harness identifiers.

Table 5: HARNESS LOCATOR 605674-005 (P1,P2,J10) TS CONTROL. WIRE No. 1-114, AWG 16. Includes wire numbers and harness identifiers.

Table 6: HARNESS LOCATOR 605674-006 (IP1,J12) STATIONARY FRAME. WIRE No. 1-12, AWG 16. Includes wire numbers and harness identifiers.

Table 7: HARNESS LOCATOR 605674-006 (IP2,J11) STATIONARY FRAME. WIRE No. 1-43, AWG 16. Includes wire numbers and harness identifiers.

Table 8: HARNESS LOCATOR 605674-007 (J3,TB1) ENGINE START. WIRE No. 120-123, AWG 16. Includes wire numbers and harness identifiers.

Table 9: HARNESS LOCATOR 605674-006 (IP3,J4) STATIONARY FRAME. WIRE No. 50-73, AWG 16. Includes wire numbers and harness identifiers.

Table 10: HARNESS LOCATOR 605674-006 (IP4,J5) STATIONARY FRAME(OPT.). WIRE No. 80-103, AWG 16. Includes wire numbers and harness identifiers.

Table 11: HARNESS LOCATOR 605674-007 (J3,TB1) ENGINE START. WIRE No. 120-123, AWG 16. Includes wire numbers and harness identifiers.

Table 12: HARNESS LOCATOR 619510-038 (J15,PL1-PL3,SS1) STD. BP CONTROL/INDICATION. WIRE No. 121-170, AWG 16. Includes wire numbers and harness identifiers.

Table 13: HARNESS LOCATOR 605674-010 (P13,BP) BP HIGH VOLTAGE. WIRE No. 1-141, AWG 16. Includes wire numbers and harness identifiers.

Table 14: HARNESS LOCATOR 605674-011 (J14,IS) ISOLATION AUX. CONTACTS. WIRE No. 140-167, AWG 16. Includes wire numbers and harness identifiers.

Table 15: HARNESS LOCATOR 605674-015 (P17,BP) BP LOW VOLTAGE. WIRE No. 170-202, AWG 16. Includes wire numbers and harness identifiers.

Table 16: HARNESS LOCATOR 619510-038 (J15,PL1-PL3,SS1) STD. BP CONTROL/INDICATION. WIRE No. 121-170, AWG 16. Includes wire numbers and harness identifiers.

Table 17: HARNESS LOCATOR 605674-013 (J15,MX,SS1,PB) OPT. BP CONTROL/INDICATION. WIRE No. 121-180, AWG 16. Includes wire numbers and harness identifiers.

Table 18: HARNESS LOCATOR 605674-014 (J16,SL1,SL2,BP(AUX5)) BP/IS INTERLOCKS. WIRE No. 154-170, AWG 16. Includes wire numbers and harness identifiers.

Table 19: HARNESS LOCATOR 605674-016 (P6,P18) INTERNAL CONTROL & FIELD INPUTS. WIRE No. 210-244, AWG 16. Includes wire numbers and harness identifiers.

Table 20: HARNESS LOCATOR 605674-017 (P,J) CONTROL PANEL EXTENSION. WIRE No. 310-312, AWG 16. Includes wire numbers and harness identifiers.

Table 21: HARNESS LOCATOR 605674-016 (P6,P18) INTERNAL CONTROL & FIELD INPUTS. WIRE No. 210-244, AWG 16. Includes wire numbers and harness identifiers.

Table 22: HARNESS LOCATOR 605674-017 (P,J) CONTROL PANEL EXTENSION. WIRE No. 310-312, AWG 16. Includes wire numbers and harness identifiers.

Table 23: HARNESS LOCATOR 605674-017 (P,J) CONTROL PANEL EXTENSION. WIRE No. 310-312, AWG 16. Includes wire numbers and harness identifiers.

Table 24: HARNESS LOCATOR 605674-017 (P,J) CONTROL PANEL EXTENSION. WIRE No. 310-312, AWG 16. Includes wire numbers and harness identifiers.

Table 25: HARNESS LOCATOR 605674-017 (P,J) CONTROL PANEL EXTENSION. WIRE No. 310-312, AWG 16. Includes wire numbers and harness identifiers.

Table 26: HARNESS LOCATOR 605674-017 (P,J) CONTROL PANEL EXTENSION. WIRE No. 310-312, AWG 16. Includes wire numbers and harness identifiers.

Project information block including PROJECT NAME, WIRING DIAGRAM 7000 SERIES (7ATB) GROUP 5 CONTROLS, DATE 6/15/01, and ASCO logo.

WIRE RUN LISTING

HARNESS LOCATOR 605749 (TB1,P11,P12,J13,P14,P15,P16,J17,J18) MAIN INTERCONNECT ASSEMBLY. WIRE No. 1-191, CLR, AWG 16.

HARNESS LOCATOR 605749 (TB1,P11,P12,J13,P14,P15,P16,J17,J18) MAIN INTERCONNECT ASSEMBLY (CONTINUED). WIRE No. 31-211, CLR, AWG 16. REMOVE WIRES and ADD WIRES sections.

HARNESS LOCATOR 605659 (P3,P4,J6,P7,TB) STD. FIELD TB. WIRE No. 120-272, CLR, AWG 16. JUMPERS and ADD WIRES sections.

HARNESS LOCATOR (J7) OPTIONAL FIELD OUTPUTS. WIRE No. 270-293, CLR, AWG 16. HARNESS LOCATOR 605454-005 (J8) OPTIONAL SERIAL I/O. WIRE No. 300-308, CLR, AWG 22 (4 COND).

HARNESS LOCATOR 483763 (J,CP-P1,CP-P2) CONTROL PANEL. WIRE No. 310-6, CLR, AWG 16. HARNESS LOCATOR 309320-005 OPTIONAL 8 IN. EXTENSION HARNESS. WIRE No. 310-312, CLR, AWG 16.

Table with columns: WIRE No., ADDITIONAL WIRING, CLR, AWG. Empty rows for wire run listing.

Table with columns: WIRE No., ADDITIONAL WIRING, CLR, AWG. Empty rows for wire run listing.

PROJECT NAME: WIRING DIAGRAM 7000 SERIES (7ATB) GROUP 5 CONTROLS. DRAWN BY: JPB, DATE: 2/98. CHECKED BY: SDH, DATE: 2/98. PROJECT NUMBER: 157978. SHEET 8 of 8.

MAIN POWER POLES

TS OPERATOR CIRCUIT

EMERGENCY

NORMAL

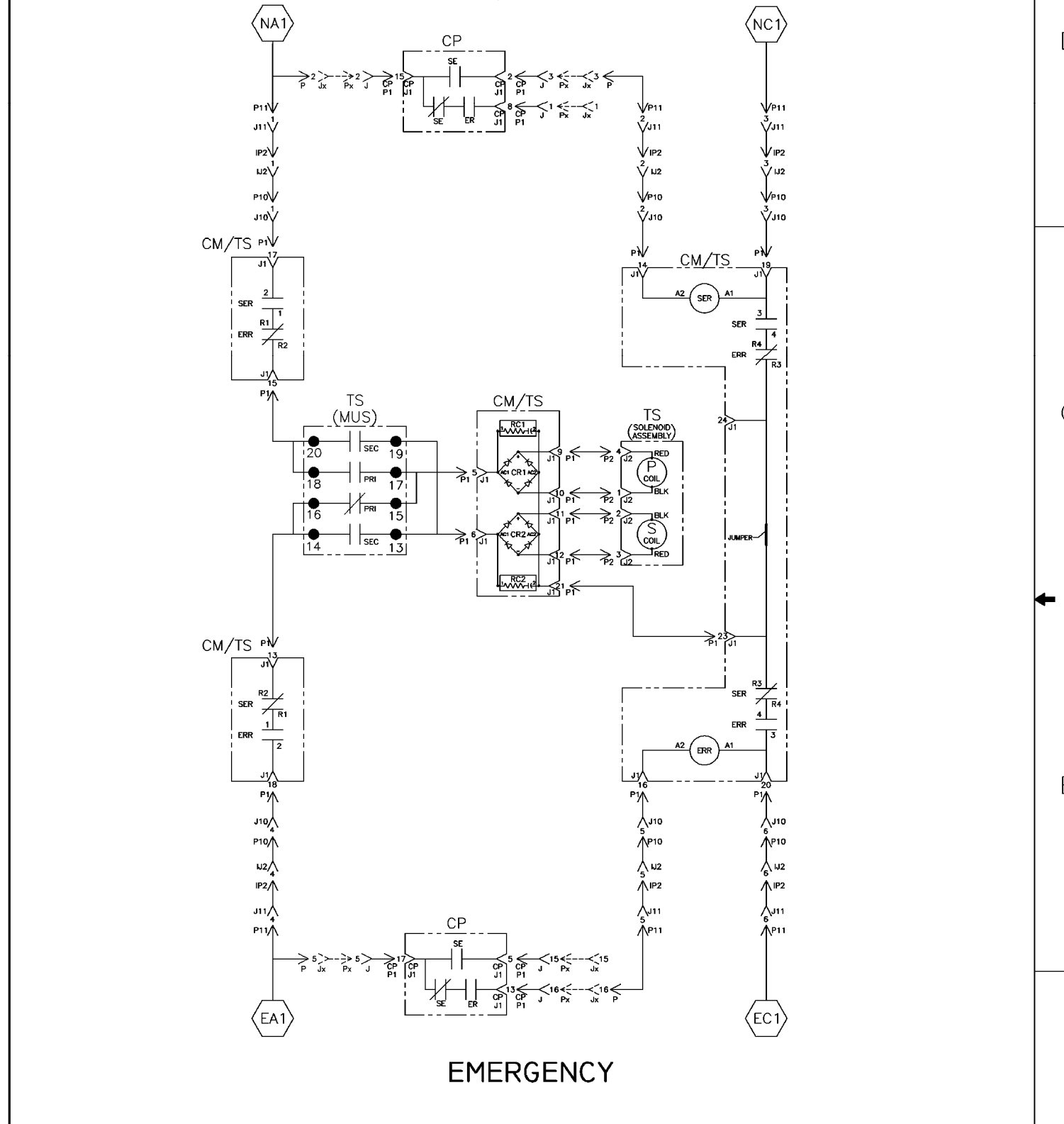
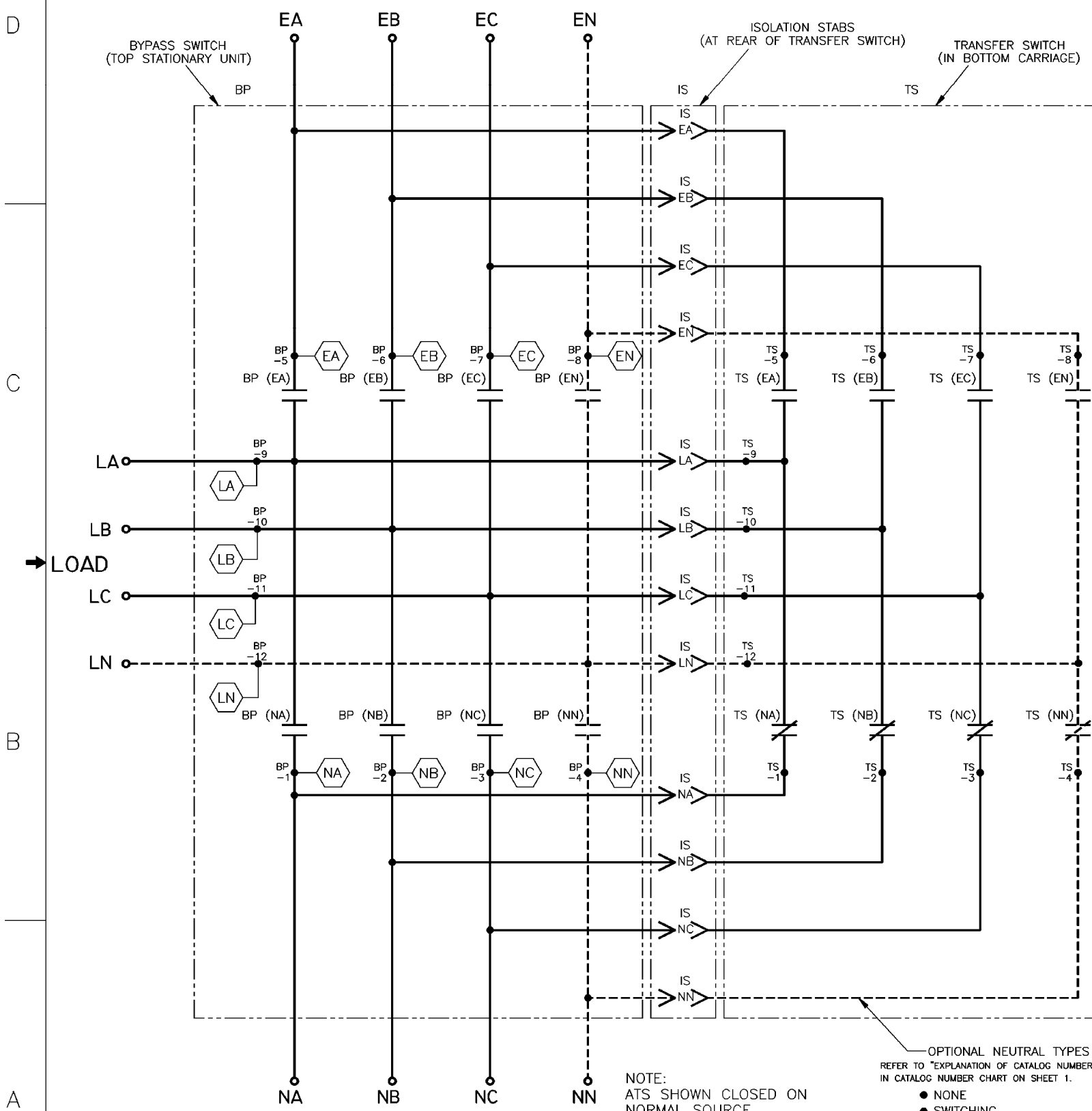

NORMAL

EMERGENCY

NOTE:  
ATS SHOWN CLOSED ON  
NORMAL SOURCE.  
BYPASS SWITCH IN  
(AUTOMATIC) POSITION.

OPTIONAL NEUTRAL TYPES  
REFER TO "EXPLANATION OF CATALOG NUMBER CODES"  
IN CATALOG NUMBER CHART ON SHEET 1.

- NONE
- SWITCHING
- OVERLAPPING CONTACTS
- SOLID BUS PLATE

TS (MUS) CONTACTS					
MUS	SOLENOID POSITION				
	NORM	>	AFTER TDC*	<	EMER
13-14					
15-16					
17-18					
19-20					

\* AFTER SOLENOID PASSES THROUGH TOP DEAD CENTER POSITION.

PROJECT NAME: WIRING DIAGRAM  
7000 SERIES (7ATB)  
GROUP 5 CONTROLS

THIRD ANGLE PROJECTION

MANUFACTURING TOLERANCES TO BE IN ACCORDANCE WITH ASQC PROCEDURE MP-1-003. FOR PLASTIC PARTS SEE MP-1-005.

PROPERTY OF ASCO POWER TECHNOLOGIES. USE PERMITTED FOR OUR WORK ONLY. ALL RIGHTS OF DESIGN OR INVENTION ARE RESERVED.

ASCO POWER TECHNOLOGIES, L.P.  
FLORHAM PARK, NEW JERSEY 07932 U.S.A.

CHANGE LETTER	E	157978	WK	BK	6/15/01
SEE ECN					
BY					
DATE					
SCALE		ACAD		FILE	
SIZE					
DWG. NO.					
DS		617421			
CHANGE LETTER	E	ECN NO.	157978	SHEET	3 OF 6