

# THREE PHASE WIRING FOR ASCO 7000 SERIES AUTOMATIC CLOSED TRANSITION TRANSFER & BYPASS-ISOLATION SWITCHES TYPE 7ACTB RATED 3000 - 4000 AMPERES

## FEATURES, SETTINGS, OPERATION & NOTES

THE FOLLOWING FEATURES AND RELATED SETTINGS ARE PART OF THE GROUP 5 CONTROL PANEL'S USER CONFIGURABLE PARAMETERS. FOR DETAILED INFORMATION REGARDING THE CONFIGURATION OF THESE PARAMETERS AND OTHER FEATURES OF THE GROUP 5 CONTROL PANEL, REFER TO THE **GROUP 5 CONTROL PANEL FOR ASCO 7000 SERIES AUTOMATIC TRANSFER SWITCHES** USER'S GUIDE (PART NO. 381333-126) PROVIDED WITH EVERY 7000 SERIES AUTOMATIC TRANSFER SWITCH.

THE NOMINAL OPERATING VOLTAGE & FREQUENCY IS PRE-PROGRAMMED AT THE FACTORY BASED ON THE NAMEPLATE DATA PRINTED ON THE TRANSFER SWITCH & CONTROL PANEL NAMEPLATES.

### VOLTAGE & FREQUENCY SENSING

THE FOLLOWING SETTINGS ARE EXPRESSED AS A PERCENTAGE OF THE CONTROL PANEL'S NOMINAL VOLTAGE SETTING UNLESS STATED OTHERWISE. ALL SETTINGS ARE ADJUSTABLE IN INCREMENTS OF 1%.

A. RMS VOLTAGE SENSING ON ALL PHASES OF THE NORMAL & EMERGENCY SOURCES.

PARAMETER	RANGE OF SETTINGS	DEFAULT SETTING
NORMAL VOLTAGE DROPOUT	70-98%	85%
NORMAL VOLTAGE PICKUP	85-100%	90%
NORMAL OVER VOLTAGE TRIP	102-115%	OFF
NORMAL VOLTAGE UNBALANCE	YES/NO	NO
NORMAL VOLTAGE UNBALANCE DROPOUT	5-20% OF AVG. NORMAL VOLTAGE	20% (if ON)
NORMAL VOLTAGE UNBALANCE PICKUP	3-18% OF AVG. NORMAL VOLTAGE	10% (if ON)
EMERGENCY VOLTAGE DROPOUT	70-98%	75%
EMERGENCY VOLTAGE PICKUP	85-100%	90%
EMERGENCY OVER VOLTAGE TRIP	102-115%	OFF
EMERGENCY VOLTAGE UNBALANCE	YES/NO	NO
EMERGENCY VOLTAGE UNBALANCE DROPOUT	5-20% OF AVG. EMERGENCY VOLTAGE	20% (if ON)
EMERGENCY VOLTAGE UNBALANCE PICKUP	3-18% OF AVG. EMERGENCY VOLTAGE	10% (if ON)

B. FREQUENCY SENSING OF THE NORMAL & EMERGENCY SOURCES.

PARAMETER	RANGE OF SETTINGS	DEFAULT SETTING
NORMAL FREQUENCY DROPOUT	85-98%	90%
NORMAL FREQUENCY PICKUP	90-100%	95%
NORMAL OVER FREQUENCY TRIP	102-110%	OFF
EMERGENCY FREQUENCY DROPOUT	85-98%	90%
EMERGENCY FREQUENCY PICKUP	90-100%	95%
EMERGENCY OVER FREQUENCY TRIP	102-110%	OFF

### TIME DELAYS

THE FOLLOWING TIME DELAY SETTINGS ALL HAVE AN ADJUSTABLE RANGE OF 0-60 min 59 sec UNLESS STATED OTHERWISE. ADJUSTABLE IN INCREMENTS OF 1 sec.  
**NOTE:** SOME TIME DELAYS MAY BE EFFECTED BY CUSTOMER REQUESTED ACCESSORIES PROVIDED WITH THE UNIT. REFER TO THE DESCRIPTIONS PROVIDED UNDER THE "ACCESSORIES" NOTES ON THIS PAGE.

FEATURE	NAME	DEFAULT SETTING
1C	NORMAL SOURCE FAILURE TO ENGINE START	1 sec
2B	TRANSFER TO EMERGENCY ON AVAILABILITY OF EMERGENCY SOURCE	0 sec
1F	EMERGENCY SOURCE FAILURE RETRANSFER (NORMAL SOURCE AVAILABLE)	0 sec
2E	ENGINE COOLDOWN FOLLOWING RETRANSFER TO NORMAL	5 min
3A	RETRANSFER TO NORMAL (NORMAL FAILURE MODE)	30 min
3A	RETRANSFER TO NORMAL (TEST MODE)	30 sec
-	DELAYED TRANSFER (LOAD "OFF" TIME), [0-5 min 59 sec]	3 sec

DESCRIPTIONS OF TIME DELAYS:

- FEAT. 1C** - DELAY ON NORMAL SOURCE OUTAGE. STARTS ON FAILURE OF NORMAL SOURCE. RESETS IF NORMAL SOURCE IS ACCEPTED BEFORE EXPIRATION. INHIBITS ENGINE STARTING AND AUTOMATIC TRANSFER UNTIL EXPIRATION.
- FEAT. 2B** - DELAY PRIOR TO TRANSFER TO THE EMERGENCY SOURCE. DELAY STARTS ON EXPIRATION OF FEAT. 1C AND WHEN THE EMERGENCY SOURCE HAS BEEN ACCEPTED. DELAY RESETS IF THE EMERGENCY SOURCE FAILS PRIOR TO EXPIRATION. ON EXPIRATION, TRANSFER TO EMERGENCY IS INITIATED UNLESS THE NORMAL SOURCE HAS RECOVERED AND THE "COMMIT TO TRANSFER" FEATURE IS SET TO "NO" COMMIT. PROVIDES A PERIOD FOR EMERGENCY SOURCE STABILIZATION OR STAGING OF MULTIPLE TRANSFER SWITCH CONTROLLED LOADS TO THE EMERGENCY SOURCE.
- FEAT. 1F** - DELAY ON RETRANSFER TO NORMAL IN THE EVENT OF EMERGENCY SOURCE FAILURE. DELAY BEGINS ON FAILURE OF THE EMERGENCY SOURCE IF THE NORMAL SOURCE IS ACCEPTABLE. ON EXPIRATION, RETRANSFER TO NORMAL WILL BE INITIATED.
- FEAT. 2E** - DELAY ON ENGINE SHUTDOWN (ENGINE COOL DOWN PERIOD). DELAY STARTS FOLLOWING RETRANSFER TO THE NORMAL SOURCE. PROVIDES A PERIOD FOR THE ENGINE-GENERATOR SET TO RUN UNLOADED PRIOR TO SHUTDOWN.
- FEAT. 3A** - RETRANSFER TO NORMAL DELAY (NORMAL FAILURE MODE) DELAY STARTS WHEN NORMAL SOURCE IS ACCEPTED (FOLLOWING IT'S FAILURE) AND WHILE THE LOAD IS CONNECTED TO EMERGENCY. RESETS IF NORMAL FAILS PRIOR TO EXPIRATION OR IF THE EMERGENCY SOURCE FAILS BEFORE EXPIRATION AND FEAT. 1F EXPIRES (AUTOMATIC BYPASS ON EMERGENCY SOURCE FAILURE). PROVIDES A PERIOD FOR THE NORMAL SOURCE TO STABILIZE PRIOR TO RETRANSFER.
- FEAT. 3A** - RETRANSFER TO NORMAL DELAY (TEST MODE) DELAY STARTS WHEN THE "TRANSFER TEST" SWITCH IS RESET TO "AUTO" (FOLLOWING A USER INITIATED TRANSFER TEST) AND WHILE THE LOAD IS CONNECTED TO EMERGENCY. RESETS IF NORMAL FAILS PRIOR TO EXPIRATION OR IF THE EMERGENCY SOURCE FAILS BEFORE EXPIRATION AND FEAT. 1F EXPIRES (AUTOMATIC BYPASS ON EMERGENCY SOURCE FAILURE).

**IN SYNC** - IN SYNC TIME DELAY BEGINS BEFORE A CLOSED TRANSITION TRANSFER FOLLOWING ACCEPTANCE OF THE SOURCE TO WHICH TRANSFER IS BEING MADE. ON EXPIRATION OF THE DELAY, THE LOGIC AWAITS AN IN SYNC CONDITION FOR SUBSEQUENT CLOSED TRANSITION TRANSFER.

**EXTENDED PARALLEL** - EXTENDED PARALLEL TIMER BEGINS WHEN THE SOURCES ARE PARALLELED (CN & CE CLOSED). IF THE TWO SOURCES REMAIN IN PARALLEL WHEN THE DELAY EXPIRES, THE CONTROL LOGIC TAKES THE FOLLOWING ACTIONS:

- THE LOGIC WILL ATTEMPT TO OPERATE THE TRANSFER SWITCH TO A "SAFE" STATE WHERE THE SOURCES WILL NO LONGER BE PARALLELED AND THE LOAD WILL BE SERVICED BY AN AVAILABLE SOURCE.
- THE CONTROL PANEL IS LOCKED OUT FROM ANY FURTHER AUTOMATIC OPERATION.
- THE "TS LOCKED OUT" INDICATOR (RED LED) IS LIT.
- THE EXTENDED PARALLEL ALARM TIMER LOCATED ON THE DUAL OPERATOR CONTROL (DOC) IS ENABLED.
- THE UNIT WILL REMAIN LOCKED OUT UNTIL THE "TS LOCKED OUT" PUSH-BUTTON IS DEPRESSED FOR RESET.

**FAIL TO SYNC** - FAILURE TO SYNC TIMER BEGINS WHEN THE LOGIC BEGINS TO CHECK FOR AN IN SYNC CONDITION FOR WHICH TO ALLOW CLOSED TRANSITION TRANSFER. IF THE DELAY EXPIRES PRIOR TO AN IN SYNC CONDITION OCCURRING, THE "FAILURE TO SYNCHRONIZE" SIGNAL IS ACTIVATED (RED LED) AND CLOSURE OF THE TFR RELAY CONTACT AVAILABLE AT THE FIELD CONNECTIONS TERMINAL BLOCK (TB).

**FEAT. 62F** - EXTENDED PARALLEL ALARM TIMER BEGINS TIMING WHEN ENABLED FOLLOWING EXPIRATION OF THE EXTENDED PARALLEL TIMER OF THE CONTROL PANEL. THE ENABLING OF THE EXTENDED PARALLEL ALARM TIMER INDICATES THAT THE UNIT HAS ATTEMPTED TO RECOVER TO A "SAFE STATE" AND THAT IT HAS BEEN LOCKED OUT. ON EXPIRATION OF THE DELAY, OUTPUT RELAY (RL3) (2) FORM C CONTACTS, CONNECTED TO THE FIELD CONNECTIONS TERMINAL BLOCK (TBO, TRANSFER. THE DELAY IS ADJUSTABLE VIA A POTENTIOMETER (P2) LOCATED ON THE DUAL OPERATOR CONTROL (DOC) WHICH IS ADJUSTABLE FROM 0-1 SECOND. FACTORY SET AT 1 SEC.

### ENGINE EXERCISER

THE ENGINE EXERCISER FEATURE PROVIDES A MEANS TO PERFORM AUTOMATIC EXERCISING OF THE ENGINE-GENERATOR SET EITHER WITH OR WITHOUT LOAD TRANSFER. THE USER CAN PROGRAM UP TO SEVEN DIFFERENT EXERCISE ROUTINES. EACH ROUTINE INCLUDES:

1. ENABLE OR DISABLE THE ROUTINE
2. ENABLE OR DISABLE TRANSFER OF THE LOAD DURING THE ROUTINE
3. SET START TIME OF ROUTINE -  
 - TIME OF DAY  
 - DAY OF WEEK  
 - WEEK OF MONTH (1st, 2nd, 3rd, 4th, ALTERNATE OR ALL)
4. SET THE DURATION OF THE ROUTINE

PARAMETER	RANGE OF SETTING	DEFAULT SETTING
MONTH (CLOCK SET)	JAN FEB MAR APR MAY JUN JUL AUG SEP OCT NOV DEC	CURRENT DATE
DAY	1-31	Eastern Standard Time
YEAR	00-99	
HOUR	0-23	
MINUTE	0-59	
ENABLE ROUTINE (ROUTINE 1-7)	YES/NO	NO
TRANSFER LOAD	YES/NO	NO
START HOUR	0-23	0
START MINUTE	0-59	0
RUN WEEK	ALL, ALTERNATE, 1st, 2nd, 3rd, 4th, 5th	ALL
RUN DAY	SUN MON TUE WED THU FRI SAT	SUN
DURATION HOURS	0-23	0
DURATION MINUTES	0-59	0

### OPERATION

IF THE NORMAL SOURCE FAILS, THE TRANSFER SWITCH INITIATES STARTING OF THE ENGINE-GENERATOR SET. WHEN PROPER VOLTAGE AND FREQUENCY HAVE BEEN ATTAINED, THE LOAD WILL BE TRANSFERRED IN AN OPEN TRANSITION (BREAK BEFORE MAKE) OPERATION TO THE EMERGENCY SOURCE.

WHEN THE NORMAL SOURCE IS RESTORED FOR THE DURATION OF THE FEATURE 3A, RETRANSFER TO NORMAL TIME DELAY SETTING, THE CONTROLS WILL BEGIN MONITORING PHASE, FREQUENCY, AND VOLTAGE DIFFERENTIAL BETWEEN NORMAL AND EMERGENCY SOURCES.

WHEN THE TWO SOURCES ARE APPROACHING SYNCHRONISM, A CLOSED TRANSITION (MAKE BEFORE BREAK) TRANSFER TO THE NORMAL SOURCE WILL BE INITIATED. THE NORMAL AND EMERGENCY CONTACTORS (CN & CE) WILL BE IN AN OVERLAP CONDITION FOR LESS THAN 0.1 SECONDS.

CLOSED TRANSITION TRANSFER WILL ALSO BE INITIATED DURING A TRANSFER TEST OPERATION CAUSED BY OPERATION OF THE FEATURE 5 TRANSFER TEST SELECTOR SWITCH. RETRANSFER WILL ALSO OCCUR IN A CLOSED TRANSITION MANNER AT THE END OF THE TEST.

**CLOSED TRANSITION BYPASS OPERATION:** THE "CT BYPASS OPTIONS" DISPLAY OF THE CONTROL PANEL ALLOWS SETTING THE TRANSFER SWITCH'S CLOSED TRANSITION BYPASS BEHAVIOR. CLOSED TRANSITION BYPASS CAUSES THE TRANSFER SWITCH TO INTERRUPT POWER TO THE LOAD DURING TRANSFER. THE AVAILABLE OPTIONS ARE:

- **FAIL TO SYNC AUTO BYPASS ENABLE** - CAUSES A "FAILURE TO SYNCHRONIZE" CONDITION TO RESULT IN AN AUTOMATIC CLOSED TRANSITION BYPASS. DEFAULT SETTING IS **NO** AUTOMATIC BYPASS.
- **CT BYPASS** - ALLOWS SELECTIONS AS TO WHETHER THE CLOSED TRANSITION BYPASS WILL OCCUR WITH OR WITHOUT A DELAYED TRANSITION (LOAD "OFF" TIME). DEFAULT SETTING IS OPEN TRANSITION (NO DELAY).
- **DT BYPASS** - SETS THE LENGTH OF THE DELAYED TRANSFER (LOAD "OFF" TIME) IF THE PREVIOUS PARAMETER HAS BEEN SELECTED TO OPERATE WITH DELAYED TRANSITION. THE DELAY ("OFF" PERIOD) BEGINS FOLLOWING THE OPENING OF THE SOURCE CONTACTOR, (CN OR CE), CONNECTED TO THE SOURCE FROM WHICH TRANSFER IS BEING MADE. UPON EXPIRATION, CLOSURE OF THE OPPOSITE SOURCE CONTACTOR IN INITIATED.

### SIGNALS & AUXILIARIES

- A. FEATURES 7 - ENGINE START SIGNAL  
 SIGNAL INITIATED BY DROPOUT OF CONTROL PANEL RELAY (NR) FOLLOWING EXPIRATION OF THE FEATURE 1C TIME DELAY (DELAY TO OVERRIDE MOMENTARY NORMAL SOURCE OUTAGES). FEATURE 7 CLOSURES TO SIGNAL ENGINE START. ENGINE STARTING SIGNAL RESETS FOLLOWING RETRANSFER TO THE NORMAL SOURCE AND EXPIRATION OF THE FEATURE 2E (ENGINE COOL DOWN) TIME DELAY.  
 FEATURE 7 CONSISTS OF A FORM A CONTACT CONNECTED TO THE FIELD CONNECTIONS TERMINAL BLOCK (TB). CONTACTS RATED 5 AMPS AT 32VDC/120VAC RESISTIVE.

BASE CATALOG NUMBER				CATALOG NUMBER SUFFIXES			EXPLANATION OF CATALOG NUMBER CODES							
CATALOG TYPE	NEUTRAL TYPE	PHASE POLES	AMPS	VOLT CODE	CONTROLLER	OPTIONAL ACCESSORY	ENCLOSURE CODE	NEUTRAL TYPE			ENCLOSURE CODES			
				A B C D E F G H J K L M N P Q R				CODE	DESCRIPTION	CODE	NOMINAL VOLTAGE	CODE	TYPE	DESCRIPTION
7ACTB	A	3	3000		5	X		BLANK	NONE	A	115	BLANK		OPEN TYPE (NO ENCLOSURE)
								A	SOLID OVERLAPPING	B	120	C	1	GENERAL PURPOSE, INDOOR
								C		E	208	E	2	INDOOR, WATER & DUST RESISTANT
								D		F	220	F	3R	OUTDOOR, RAINPROOF, SLEET & ICE RESISTANT
								E		G	230	G	4	INDOOR/OUTDOOR, WATERTIGHT & DUSTTIGHT
								F		H	240	H	4X	TYPE 4 PLUS CORROSION RESISTANCE (STAINLESS STEEL)
								G		J	277	J	4X	TYPE 4 PLUS CORROSION RESISTANCE (FIBERGLASS)
								H		K	380	K	7	EXPLOSION PROOF
								J		L	400	L	12	INDOOR, INDUSTRIAL ENVIRONMENTS, OILTIGHT & DUSTTIGHT
								K			415			
								L			440			
								M			460			
								N			480			
								P			550			
								Q			575			
								R			600			
	BLANK FOR NONE													BLANK FOR OPEN TYPE

B. FEATURES 14AC & 14BB - TRANSFER SWITCH AUXILIARY POSITION INDICATING CONTACTS. FOUR (4) FORM A CONTACTS TO INDICATE CONNECTION OF THE TRANSFER SWITCH TO NORMAL (14A) AND THREE (3) FOR EMERGENCY (14B). CONTACTS CONNECTED TO THE FIELD CONNECTIONS TERMINAL BLOCK (TB). CONTACTS RATED 10 AMPS, 32 VDC, 250 VAC.

C. FEATURE 17 - REMOTE TRANSFER TO EMERGENCY. REQUIRES A CUSTOMER SUPPLIED NORMALLY OPEN CONTACT. CLOSING OF THE CONTACT CAUSES ENGINE START AND TRANSFER TO THE EMERGENCY SOURCE. OPENING OF THE CONTACT ACTIVATES THE FEATURE 3A (RETRANSFER TO NORMAL) DELAY PRIOR TO RETRANSFER. IN THE EVENT THE EMERGENCY SOURCE FAILS WHILE THE TRANSFER SWITCH IS CONNECTED TO EMERGENCY AND THE REMOTE CONTACT IS CLOSED, THE TRANSFER SWITCH WILL RETRANSFER TO THE NORMAL SOURCE. CONNECTED TO THE FIELD CONNECTIONS TERMINAL BLOCK (TB).

### USER CONTROLS AND INDICATIONS

A. FEATURES 5 & 6B - TRANSFER TEST/RETRANSFER TIME DELAY BYPASS CONTROLS.

**TRANSFER TEST:**  
 OPERATION CAUSES A NORMAL SOURCE FAILURE SEQUENCE. ACTIVATE AND HOLD FOR AT LEAST 15 SECONDS TO ALLOW TIME FOR THE ENGINE-GENERATOR TO START.

**RETRANSFER TIME DELAY BYPASS:**  
 OPERATION WILL BYPASS THE FEATURE 3A (RETRANSFER TO NORMAL DELAY).

B. FEATURES 9A & 9B - TRANSFER SWITCH POSITION INDICATORS.  
 FEATURE 9A: TRANSFER SWITCH CLOSED ON NORMAL (GREEN LED)  
 FEATURE 9B: TRANSFER SWITCH CLOSED ON EMERGENCY (RED LED)

C. FEATURES 9C & 9D - SOURCE ACCEPTANCE INDICATORS.  
 FEATURE 9C: NORMAL SOURCE ACCEPTED (GREEN LED)  
 FEATURE 9D: EMERGENCY SOURCE ACCEPTED (RED LED)

D. EXTENDED PARALLEL TIME - INDICATES THAT THE MAIN CONTACTORS (CN & CE) HAVE BEEN SIMULTANEOUSLY CLOSED FOR A PERIOD EXCEEDING THE TIME ALLOTTED. (RED LED)

E. FAILURE TO SYNCHRONIZE - INDICATES THE TWO SOURCES DID NOT MEET THE PARAMETERS REQUIRED FOR A CLOSED TRANSITION TRANSFER. (RED LED)

F. TS LOCKED OUT - INDICATES THAT A FAILURE OF THE TRANSFER SWITCH OPERATOR HAS OCCURRED AND THAT THE TRANSFER SWITCH HAS TAKEN CORRECTIVE ACTION AS REQUIRED. ONCE THIS FAILURE RECOVERY OPERATION TAKES PLACE, THE TRANSFER SWITCH IS PREVENTED FROM FURTHER OPERATION UNTIL THE CONDITION IS CORRECTED. ONCE THE CONDITION IS CORRECTED, THE TS LOCKED OUT SWITCH MAY BE DEPRESSED TO RESET THE CONTROL PANEL (RED LED).

G. ALARM RESET SWITCH - RESETS FAILURE TO SYNCHRONIZE AND EXTENDED PARALLEL ALARMS.

H. CLOSED TRANSITION BYPASS SWITCH - BYPASSES CLOSED TRANSITION TRANSFER WHEN OPERATED DURING THE PERIOD WHILE THE TRANSFER SWITCH CONTROL PANEL IS MONITORING FOR AN INPHASE CONDITION. CAUSES OPEN TRANSITION TRANSFER TO THE OPPOSITE SOURCE IF CONDITIONS PERMIT.

### BYPASS SWITCH USER CONTROLS & INDICATIONS

A. SOURCE AVAILABILITY INDICATORS:  
 NORMAL SOURCE AVAILABLE: (GREEN LED)  
 EMERGENCY SOURCE AVAILABLE: (RED LED)

B. BYPASS SWITCH POSITION INDICATORS:  
 BYPASS SWITCH NORMAL CONTACTS CLOSED: (GREEN, LED)  
 BYPASS SWITCH EMERGENCY CONTACTS CLOSED: (RED, LED)

C. ISOLATION CONTACTS POSITION INDICATORS:  
 ISOLATION CONTACTS IN DISCONNECTED POSITION: (RED, LED)  
 ISOLATION CONTACTS IN TEST POSITION: (AMBER, LED)  
 ISOLATION CONTACTS IN CONNECTED POSITION: (GREEN, LED)

D. TRANSFER SWITCH POSITION INDICATORS:  
 TRANSFER SWITCH CLOSED ON NORMAL: (GREEN, LED)  
 TRANSFER SWITCH CLOSED ON EMERGENCY: (RED, LED)

E. SOLENOID INTERLOCKS -  
 SL1: INTERLOCKS THE TRANSFER SWITCH ISOLATION CRANK WITH THE TRANSFER SWITCH AND BYPASS SWITCH TO INSURE THAT THE TRANSFER SWITCH CAN NEVER BE DISCONNECTED WITHOUT BEING BYPASSED AND THAT IT CAN NEVER BE RECONNECTED UNLESS IT IS IN THE SAME POSITION AS THE BYPASS SWITCH.  
 SL2: INTERLOCKS THE BYPASS SWITCH OPERATOR, WHILE IN THE CONNECTED POSITION, SO THAT THE BYPASS SWITCH CAN NEVER BE OPERATED TO THE SOURCE OPPOSITE OF WHICH THE TRANSFER IS CONNECTED.

### GENERAL NOTES

1. SWITCH SHOWN DE-ENERGIZED AND CONNECTED TO THE NORMAL SOURCE. THE BYPASS SWITCH OPERATOR IS IN THE "AUTOMATIC" POSITION (NORMAL & EMERGENCY BYPASS CONTACTS OPEN). THE ISOLATION HANDLE IS IN THE "CLOSED" POSITION (ATS CONNECTED).
2. DEVICE SYMBOLS AND DESIGNATIONS ARE IN ACCORDANCE WITH NEMA PUBLICATION ICS 1-1983, PART 1-101A.
3. ALL WIRING IS #16 AWG, TINNED, STRANDED COPPER UNLESS OTHERWISE INDICATED.
4. O ON TERMINAL BLOCKS INDICATES AVAILABLE FIELD CONNECTION POINT.
5. ● ON TERMINAL BLOCKS INDICATES FACTORY CONNECTION POINT.
6. CONTROL AND ACCESSORY WIRING IS ROUTED IN ACCORDANCE WITH ASCO ASSEMBLY PROCEDURE GS451261.
7. AN OPERATOR'S MANUAL IS FURNISHED WITH EACH AUTOMATIC TRANSFER SWITCH. REFER TO THIS PUBLICATION PRIOR TO INSTALLATION AND OPERATION OF THE UNIT.

CATALOG NUMBER \_\_\_\_\_  
 CERTIFIED TO  
**ASCO**® S.O. \_\_\_\_\_  
 BY \_\_\_\_\_  
 DATE \_\_\_\_\_

FORM REV E

PROJECT NAME: \_\_\_\_\_

WIRING DIAGRAM

7000 SERIES (7ACTB) GROUP 5 CONTROLS

THIRD ANGLE PROJECTION

MANUFACTURING TOLERANCES TO BE IN ACCORDANCE WITH ASCO PROCEDURE MP-1-003. FOR PLASTIC PARTS SEE MP-1-005.

PROPERTY OF ASCO POWER TECHNOLOGIES. USE PERMITTED FOR OUR WORK ONLY. ALL RIGHTS OF DESIGN OR INVENTION ARE RESERVED.

ASCO POWER TECHNOLOGIES, L.P.  
 FLORHAM PARK, NEW JERSEY 07932 U.S.A.

SCALE: \_\_\_\_\_  
 DWG. NO.: \_\_\_\_\_  
 FILE: \_\_\_\_\_

DS617426

SHEET 1 OF 10

TECHNICAL DATA & ACCESSORIES

TECHNICAL DATA

BYPASS SWITCH AUXILIARY CONTACTS

AUX. CONT.	BYPASS HANDLE POSITION		
	EMERG	AUTO	NORMAL
1-2			
7-8			
9-10			
11-12			
13-14			
15-16			
17-18			
19-20			
21-22			
3-4	THESE CONTACTS CAN BE EITHER OPEN OR CLOSED IN AUTOMATIC POSITION DEPENDING UPON WHETHER HANDLE IS IN OR OUT		
6-5			

ISOLATION AUXILIARY CONTACTS

AUX. CONT.	CARRIAGE IN	MAIN CONT. ENGAGE	TEST POSITION	CARRIAGE OUT
1-2				
3-4				
5-6				
7-8				
13-14				
15-16				
17-18				
17-21				
19-20				
23-24				
26-27				
26-28				

E	158390	BK	BK	8/10/01
	SEE ECN			
D	157178	BWM	BK	5/24/01
	SEE ECN			
C	155444	BK	BK	8/00
	SEE ECN			
B	153491	BK	BK	12/15/99
	SEE ECN			
A	148918	KU	JPB	8/98
	SEE ECN			
-	147911	JPB		4/98
	ISSUE			

PROJECT NAME		WIRING DIAGRAM		THIRD ANGLE PROJECTION	
DRAWN BY JPB		DATE 4/98		MANUFACTURING TOLERANCES TO BE IN ACCORDANCE WITH ASCO PROCEDURE MP-1-003 FOR PLASTIC PARTS SEE MP-1-055	
CHECKED		DRAWING APPROVAL		ASSEMBLY REF. NO.	
FINAL APPROVAL		SDH 4/98		SCALE: ACAD FILE SIZE: DMC. NO. <b>DS1617426</b> CHANGE LETTER E ECN NO. 158390 SHEET 2 OF 10	
PROPERTY OF ASCO POWER TECHNOLOGIES. USE PERMITTED FOR OUR WORK ONLY. ALL RIGHTS OF DESIGN OR INVENTION ARE RESERVED.				ASCO POWER TECHNOLOGIES, L.P. FLORHAM PARK, NEW JERSEY 07932 U.S.A.	

# FIELD CONNECTIONS

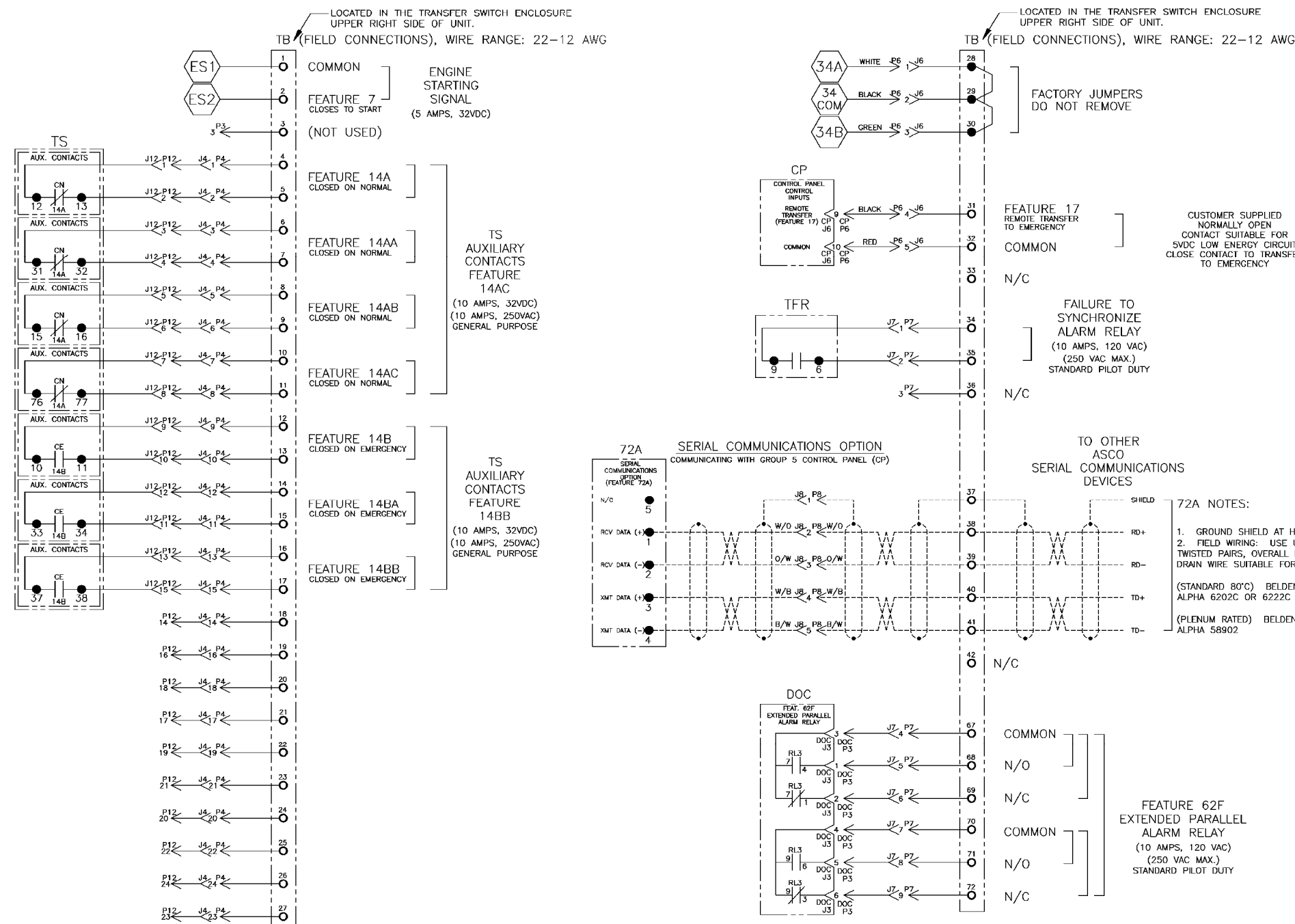

E	158390	BK	BK	8/10/01
D	157178	BWM	BK	5/24/01
C	155444	BK	BK	8/00
B	153491	BK	BK	12/15/99
A	148918	KU	JPB	8/98
-	147911	JPB		4/98
-				ISSUE

PROJECT NAME		WIRING DIAGRAM	
DRAWN BY		DATE	
CHECKED		DATE	
DRAFTING APPROVAL		DATE	
FINAL APPROVAL		DATE	
ASCO		ASCO POWER TECHNOLOGIES, L.P. FLORHAM PARK, NEW JERSEY 07932 U.S.A.	
SUBSIDIARY DISTRIBUTION		COMPUTER GENERATED DRAWING	
SCALE		ACAD FILE	
SIZE (DIM. NO.)		DS1617426	
CHANGE LETTER		E	
ECN NO.		158390	
BY		APP.	
DATE		DATE	

MAIN POWER POLES

TS OPERATOR CIRCUIT

EMERGENCY

NORMAL

NORMAL

EMERGENCY

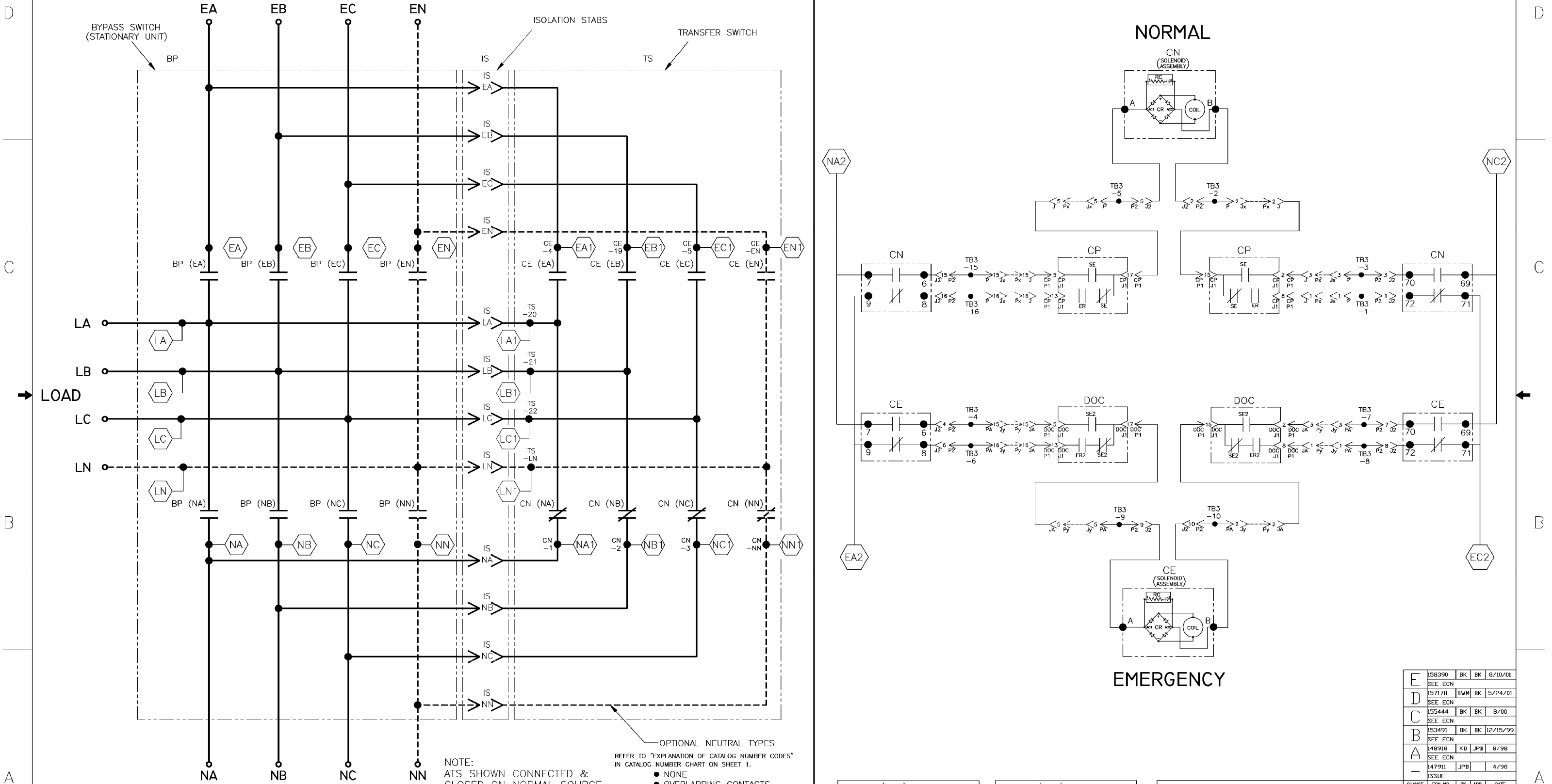

NOTE:  
ATS SHOWN CONNECTED &  
CLOSED ON NORMAL SOURCE.  
BYPASS SWITCH IN  
(AUTOMATIC) POSITION.

OPTIONAL NEUTRAL TYPES  
REFER TO "EXPLANATION OF CATALOG NUMBER CODES"  
IN CATALOG NUMBER CHART ON SHEET 1.

- NONE
- OVERLAPPING CONTACTS
- SOLID BUS PLATE

CN (MUS) CONTACTS		SOLENOID POSITION	
MUS	CLOSED BEFORE NORMAL	BEFORE TDC >	BEFORE <TDC OPEN
7-6			
69-70			
8-9			
71-72			

CE (MUS) CONTACTS		SOLENOID POSITION	
MUS	OPEN BEFORE TDC >	BEFORE <TDC	CLOSED BEFORE EMERG.
7-6			
69-70			
8-9			
71-72			

PROJECT NAME: **WIRING DIAGRAM**

**7000 SERIES (7ACTB) GROUP 5 CONTROLS**

MANUFACTURING TOLERANCES TO BE IN ACCORDANCE WITH ASCO PROCEDURE MP-1-003. FOR PLASTIC PARTS SEE MP-1-055.

PROPERTY OF ASCO POWER TECHNOLOGIES. USE PERMITTED FOR OUR WORK ONLY. ALL RIGHTS OF DESIGN OR INVENTION ARE RESERVED.

ASCO POWER TECHNOLOGIES, L.P.  
FLORHAM PARK, NEW JERSEY 07932 U.S.A.

E	158390	BK	BK	8/10/01
D	157178	BWM	BK	5/24/01
C	155444	BK	BK	8/00
B	153491	BK	BK	12/15/99
A	148918	KU	JPB	8/98
-	147911	JPB		4/98

CHANGE LETTER	EDN NO.	BY	APP.	DATE

SUBSIDIARY DISTRIBUTION	
AE	<input type="checkbox"/> AN <input type="checkbox"/> AW <input type="checkbox"/> AX <input type="checkbox"/> AL <input type="checkbox"/>
CH	<input type="checkbox"/> AV <input type="checkbox"/> AR <input type="checkbox"/> AS <input type="checkbox"/> AP <input type="checkbox"/>
AG	<input type="checkbox"/> AP <input type="checkbox"/> AC <input type="checkbox"/> AS <input type="checkbox"/>

COMPUTER GENERATED DRAWING

SCALE:  ACAD  FILE

SIZE:  DMC  NO.

DS617426

CHANGE LETTER E EDN NO. 158390 SHEET 4 OF 10

NORMAL SOURCE CIRCUITS

NORMAL

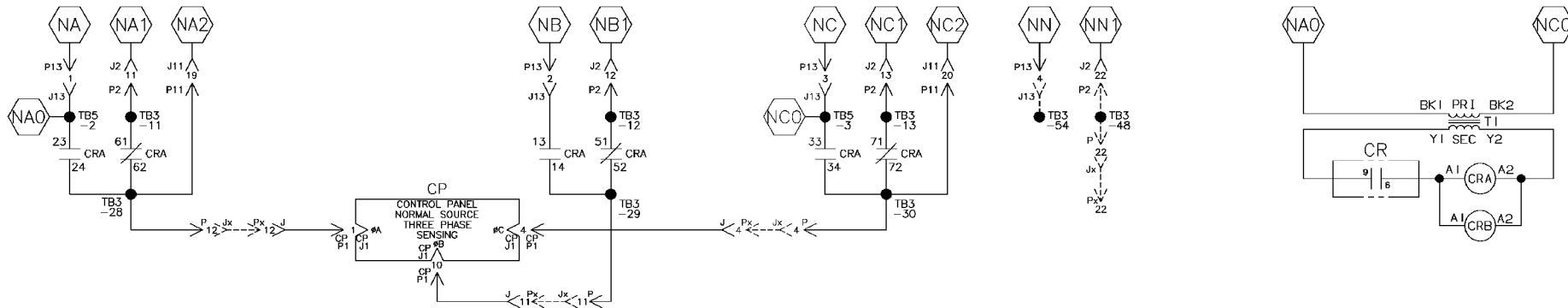

EMERGENCY SOURCE CIRCUITS

EMERGENCY

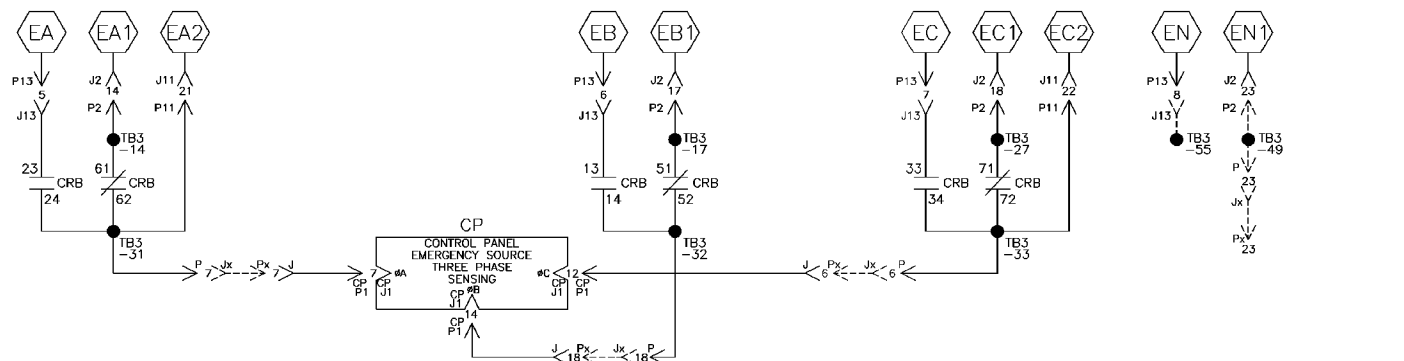

LOAD TERMINAL CIRCUITS

LOAD

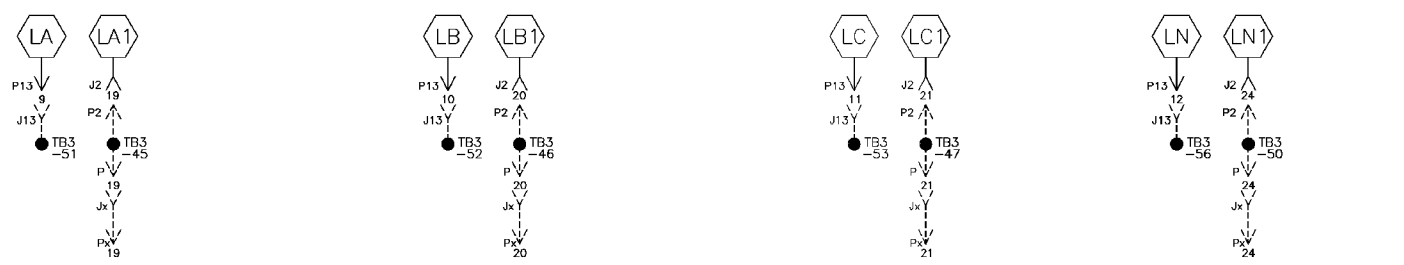

CONTROL SIGNALS & INDICATION

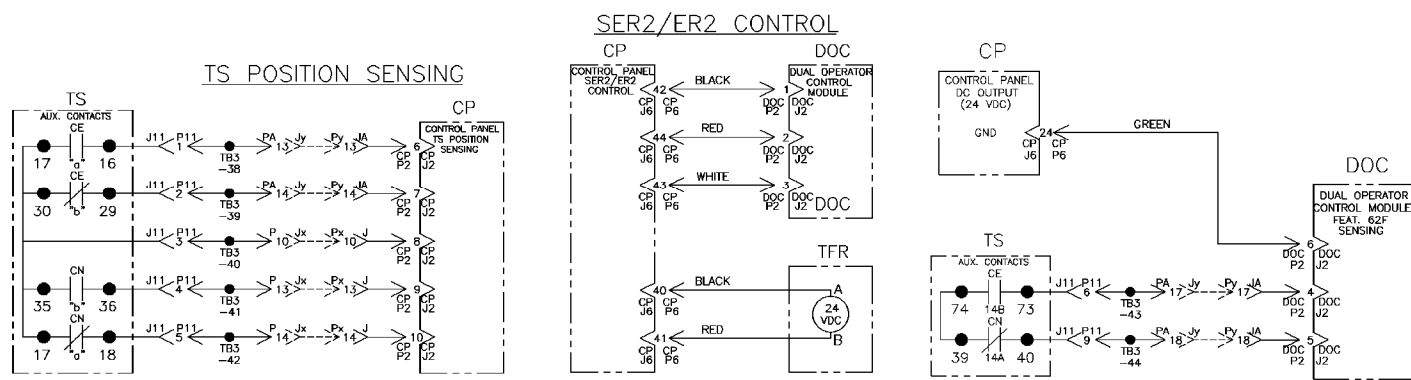

ENGINE START CIRCUIT

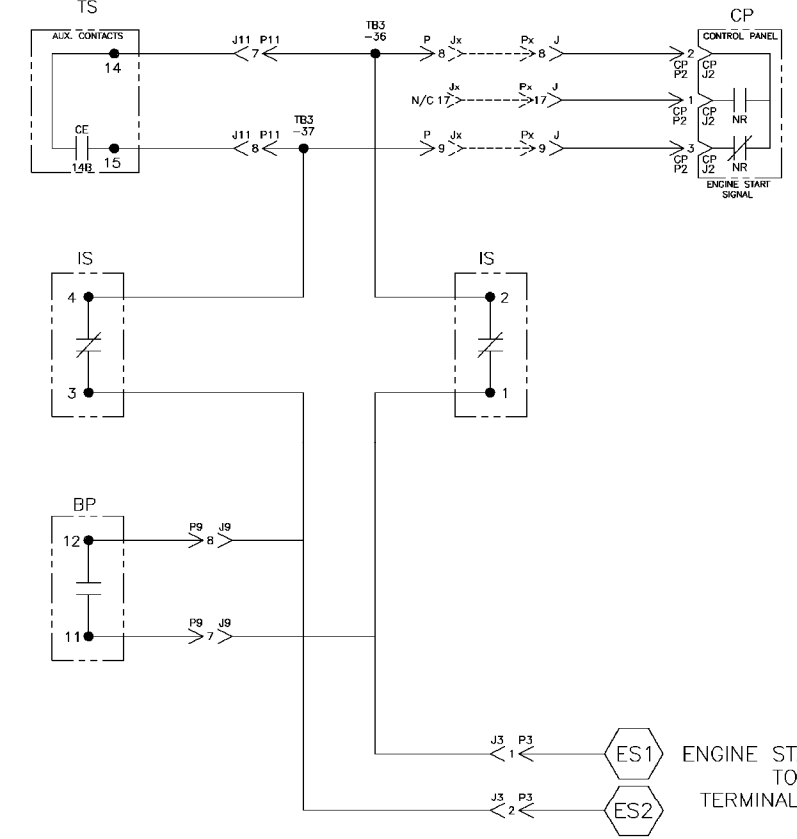

CONTROL PANEL/BYPASS-ISOLATION INTERLOCKS

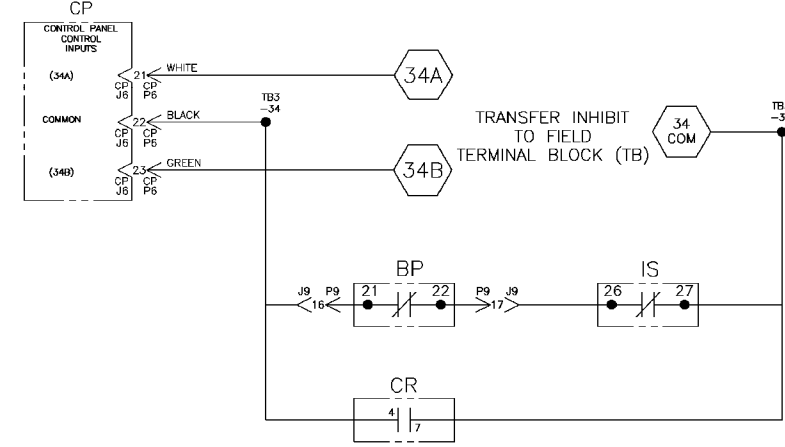

E	158390	BK	BK	8/10/01
D	157178	BWM	BK	5/24/01
C	155444	BK	BK	8/00
B	153491	BK	BK	12/15/99
A	148918	KU	JPB	8/98
-	147911	JPB		4/98
-	ISSUE			
CHANGE LETTER	EDN NO.	BY	APP.	DATE
SUBSIDIARY DISTRIBUTION				
AE	AN	AM	AL	AL
CH	AV	AM	PS	AR
AG	AP	AC	AS	AS
COMPUTER GENERATED DRAWING				
SCALE		ACAD FILE		
SIZE		DWC NO.		
DRAWING APPROVAL		DS617426		
CHANGE LETTER		EDN NO. 158390 SHEET 5 OF 10		

PROJECT NAME		DIAGRAM	
WIRING		7000 SERIES (7ACTB)	
GROUP 5 CONTROLS		ASCO POWER TECHNOLOGIES, L.P.	
BY	DATE	MANUFACTURING TOLERANCES TO BE IN ACCORDANCE WITH ASCO PROCEDURE MP-1-003 FOR PLASTIC PARTS. SEE MP-1-055.	
DRAWN BY	JPB	4/98	ASSEM. REF. NO.
CHECKED			PROPERTY OF ASCO POWER TECHNOLOGIES. USE PERMITTED FOR OUR WORK ONLY. ALL RIGHTS OF DESIGN OR INVENTION ARE RESERVED.
DRAWING APPROVAL	SDH	4/98	ASCO POWER TECHNOLOGIES, L.P. FLOHAM PARK, NEW JERSEY 07932 U.S.A.
FINAL APPROVAL			

8 7 6 5 4 3 2 1  
 ADDITIONAL CIRCUITS

D

D

C

C

B

B

A

A

E	158390	BK	BK	8/10/01
SEE ECN				
D	157178	BWM	BK	5/24/01
SEE ECN				
C	155444	BK	BK	8/00
SEE ECN				
B	153491	BK	BK	12/15/99
SEE ECN				
A	148918	KU	JPB	8/98
SEE ECN				
-	147911	JPB		4/98
ISSUE				

PROJECT NAME		WIRING DIAGRAM		THIRD ANGLE PROJECTION	
DRAWN BY JPB		DATE 4/98		MANUFACTURING TOLERANCES TO BE IN ACCORDANCE WITH ASCO PROCEDURE MP-1-003. FOR PLASTIC PARTS SEE MP-1-055.	
CHECKED		DRAFTING APPROVAL SDH 4/98		PROPERTY OF ASCO POWER TECHNOLOGIES. USE PERMITTED FOR OUR WORK ONLY. ALL RIGHTS OF DESIGN OR INVENTION ARE RESERVED.	
FINAL APPROVAL		ASCO		ASCO POWER TECHNOLOGIES, L.P. FLORHAM PARK, NEW JERSEY 07932 U.S.A.	
CHANGE LETTER E		ECN NO. 158390		SON NO. 158390	
SUBSIDIARY DISTRIBUTION		COMPUTER GENERATED DRAWING		SCALE	
AE	AN	AW	AX	AL	AL
CH	AV	AW	PS	AR	AR
AG	AP	AC	AS		
SIZE		DWC. NO.		DS1617426	
CHANGE LETTER E		ECN NO. 158390		SHEET 6 OF 10	

BYPASS / ISOLATION INTERLOCKING & INDICATION

ADDITIONAL CIRCUITS

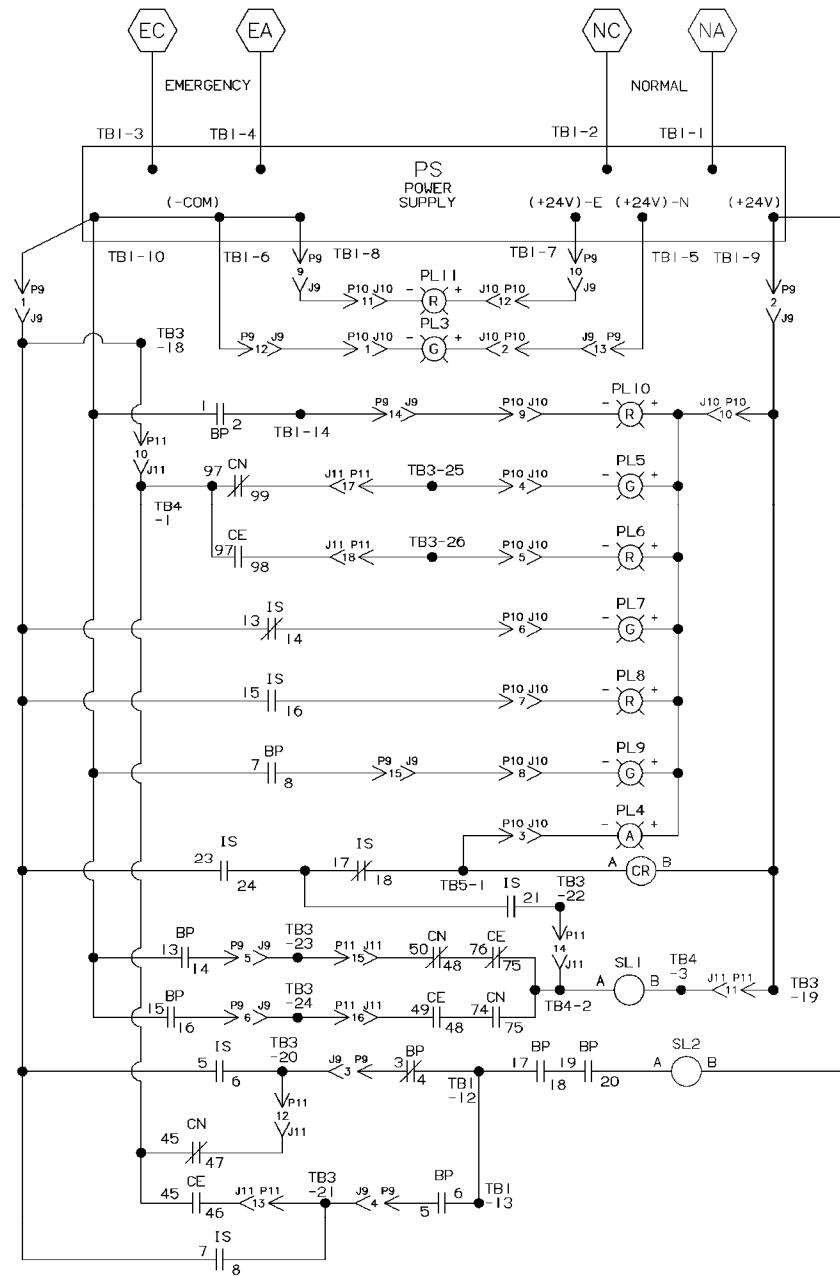

E	158390	BK	BK	8/10/01
D	157178	BWM	BK	5/24/01
C	155444	BK	BK	8/00
B	153491	BK	BK	12/15/99
A	148918	KU	JPB	8/98
-	147911	JPB		4/98
-				ISSUE

PROJECT NAME:		WIRING DIAGRAM	
DRAWN BY: JPB		DATE: 4/98	
CHECKED:		DRAFTING APPROVAL: SDH	
FINAL APPROVAL:		DATE: 4/98	
MANUFACTURING TOLERANCES TO BE IN ACCORDANCE WITH ASCO PROCEDURE MP-1-003. FOR PLASTIC PARTS SEE MP-1-055.		ASSEM. REF. NO.: SCALE: ACAD FILE SIZE: DMC. NO. DS617426 CHANGE LETTER: E CON. NO.: 158390 SHEET 7 OF 10	
PROPERTY OF ASCO POWER TECHNOLOGIES. USE PERMITTED FOR OUR WORK ONLY. ALL RIGHTS OF DESIGN OR INVENTION ARE RESERVED.		ASCO POWER TECHNOLOGIES, L.P. FLORHAM PARK, NEW JERSEY 07932 U.S.A.	



WIRE RUN LISTING

HARNESS LOCATOR 619510-027 (P2,P11,TB3) CLR AWG 16. Table listing wire numbers and harness details.

HARNESS LOCATOR 619510-011 (J2,J11,J12,TB4) IS CLR AWG 16. Table listing wire numbers and harness details.

HARNESS LOCATOR 619510-029 (J9,J13,P10,IS,TB3) CLR AWG 16. Table listing wire numbers and harness details.

HARNESS LOCATOR (IS,CR,CRA,CRB,TB5) INTERCONNECT CLR AWG 16. Table listing wire numbers and harness details.

HARNESS LOCATOR 619510-005 (P6) FIELD INPUTS CLR AWG 16. Table listing wire numbers and harness details.

HARNESS LOCATOR 605454-005 (J8) OPTIONAL SERIAL I/O CLR AWG 16. Table listing wire numbers and harness details.

HARNESS LOCATOR SUB-ASSEMBLY 605659 (P3,P4,J6,P7,TB) STD. FIELD TB CLR AWG 16. Table listing wire numbers and harness details.

HARNESS LOCATOR 619510-028 (P,PA,TB3) CLR AWG 16. Table listing wire numbers and harness details.

HARNESS LOCATOR 619510-030 (J3,IS) ENGINE START CLR AWG 16. Table listing wire numbers and harness details.

HARNESS LOCATOR 619510-010 (P9,P13,TB1,BP) INTERCONNECTION CLR AWG 16. Table listing wire numbers and harness details.

HARNESS LOCATOR 483763 (J,CP-P1,CP-P2) CONTROL PANEL CLR AWG 16. Table listing wire numbers and harness details.

HARNESS LOCATOR 619510-010 (P9,P13,TB1,BP) INTERCONNECTION CLR AWG 16. Table listing wire numbers and harness details.

HARNESS LOCATOR 483763 (J,CP-P1,CP-P2) CONTROL PANEL CLR AWG 16. Table listing wire numbers and harness details.

HARNESS LOCATOR 483763 (J,CP-P1,CP-P2) CONTROL PANEL CLR AWG 16. Table listing wire numbers and harness details.

HARNESS LOCATOR 619510-030 (J3,IS) ENGINE START CLR AWG 16. Table listing wire numbers and harness details.

HARNESS LOCATOR 619510-030 (J3,IS) ENGINE START CLR AWG 16. Table listing wire numbers and harness details.

HARNESS LOCATOR 619510-010 (P9,P13,TB1,BP) INTERCONNECTION CLR AWG 16. Table listing wire numbers and harness details.

HARNESS LOCATOR 483763 (J,CP-P1,CP-P2) CONTROL PANEL CLR AWG 16. Table listing wire numbers and harness details.

HARNESS LOCATOR 619510-010 (P9,P13,TB1,BP) INTERCONNECTION CLR AWG 16. Table listing wire numbers and harness details.

HARNESS LOCATOR 483763 (J,CP-P1,CP-P2) CONTROL PANEL CLR AWG 16. Table listing wire numbers and harness details.

HARNESS LOCATOR 483763 (J,CP-P1,CP-P2) CONTROL PANEL CLR AWG 16. Table listing wire numbers and harness details.

PROJECT NAME: WIRING DIAGRAM 7000 SERIES (7ACTB) GROUP 5 CONTROLS. Includes drawing information, scale, and drawing number DS1617426.

Change letter table with columns for change letter, ECD No., by, app., date, and issue.

Subsidiary distribution table with columns for AE, AN, AP, AS, AR, AT, AU, AV, AW, AX, AY, AZ, BA, BB, BC, BD, BE, BF, BG, BH, BI, BJ, BK, BL, BM, BN, BO, BP, BQ, BR, BS, BT, BU, BV, BW, BX, BY, BZ, CA, CB, CC, CD, CE, CF, CG, CH, CI, CJ, CK, CL, CM, CN, CO, CP, CQ, CR, CS, CT, CU, CV, CW, CX, CY, CZ, DA, DB, DC, DD, DE, DF, DG, DH, DI, DJ, DK, DL, DM, DN, DO, DP, DQ, DR, DS, DT, DU, DV, DW, DX, DY, DZ, EA, EB, EC, ED, EE, EF, EG, EH, EI, EJ, EK, EL, EM, EN, EO, EP, EQ, ER, ES, ET, EU, EV, EW, EX, EY, EZ, FA, FB, FC, FD, FE, FF, FG, FH, FI, FJ, FK, FL, FM, FN, FO, FP, FQ, FR, FS, FT, FU, FV, FW, FX, FY, FZ, GA, GB, GC, GD, GE, GF, GG, GH, GI, GJ, GK, GL, GM, GN, GO, GP, GQ, GR, GS, GT, GU, GV, GW, GX, GY, GZ, HA, HB, HC, HD, HE, HF, HG, HH, HI, HJ, HK, HL, HM, HN, HO, HP, HQ, HR, HS, HT, HU, HV, HW, HX, HY, HZ, IA, IB, IC, ID, IE, IF, IG, IH, II, IJ, IK, IL, IM, IN, IO, IP, IQ, IR, IS, IT, IU, IV, IW, IX, IY, IZ, JA, JB, JC, JD, JE, JF, JG, JH, JI, JJ, JK, JL, JM, JN, JO, JP, JQ, JR, JS, JT, JU, JV, JW, JX, JY, JZ, KA, KB, KC, KD, KE, KF, KG, KH, KI, KJ, KK, KL, KM, KN, KO, KP, KQ, KR, KS, KT, KU, KV, KW, KX, KY, KZ, LA, LB, LC, LD, LE, LF, LG, LH, LI, LJ, LK, LL, LM, LN, LO, LP, LQ, LR, LS, LT, LU, LV, LW, LX, LY, LZ, MA, MB, MC, MD, ME, MF, MG, MH, MI, MJ, MK, ML, MM, MN, MO, MP, MQ, MR, MS, MT, MU, MV, MW, MX, MY, MZ, NA, NB, NC, ND, NE, NF, NG, NH, NI, NJ, NK, NL, NM, NN, NO, NP, NQ, NR, NS, NT, NU, NV, NW, NX, NY, NZ, OA, OB, OC, OD, OE, OF, OG, OH, OI, OJ, OK, OL, OM, ON, OO, OP, OQ, OR, OS, OT, OU, OV, OW, OX, OY, OZ, PA, PB, PC, PD, PE, PF, PG, PH, PI, PJ, PK, PL, PM, PN, PO, PP, PQ, PR, PS, PT, PU, PV, PW, PX, PY, PZ, QA, QB, QC, QD, QE, QF, QG, QH, QI, QJ, QK, QL, QM, QN, QO, QP, QQ, QR, QS, QT, QU, QV, QW, QX, QY, QZ, RA, RB, RC, RD, RE, RF, RG, RH, RI, RJ, RK, RL, RM, RN, RO, RP, RQ, RR, RS, RT, RU, RV, RW, RX, RY, RZ, SA, SB, SC, SD, SE, SF, SG, SH, SI, SJ, SK, SL, SM, SN, SO, SP, SQ, SR, SS, ST, SU, SV, SW, SX, SY, SZ, TA, TB, TC, TD, TE, TF, TG, TH, TI, TJ, TK, TL, TM, TN, TO, TP, TQ, TR, TS, TT, TU, TV, TW, TX, TY, TZ, UA, UB, UC, UD, UE, UF, UG, UH, UI, UJ, UK, UL, UM, UN, UO, UP, UQ, UR, US, UT, UY, UZ, VA, VB, VC, VD, VE, VF, VG, VH, VI, VJ, VK, VL, VM, VN, VO, VP, VQ, VR, VS, VT, VU, VV, VW, VX, VY, VZ, WA, WB, WC, WD, WE, WF, WG, WH, WI, WJ, WK, WL, WM, WN, WO, WP, WQ, WR, WS, WT, WU, WV, WW, WX, WY, WZ, XA, XB, XC, XD, XE, XF, XG, XH, XI, XJ, XK, XL, XM, XN, XO, XP, XQ, XR, XS, XT, XU, XV, XW, XX, XY, XZ, YA, YB, YC, YD, YE, YF, YG, YH, YI, YJ, YK, YL, YM, YN, YO, YP, YQ, YR, YS, YT, YU, YV, YW, YX, YY, YZ, ZA, ZB, ZC, ZD, ZE, ZF, ZG, ZH, ZI, ZJ, ZK, ZL, ZM, ZN, ZO, ZP, ZQ, ZR, ZS, ZT, ZU, ZV, ZW, ZX, ZY, ZZ.

