

FIELD CONNECTIONS

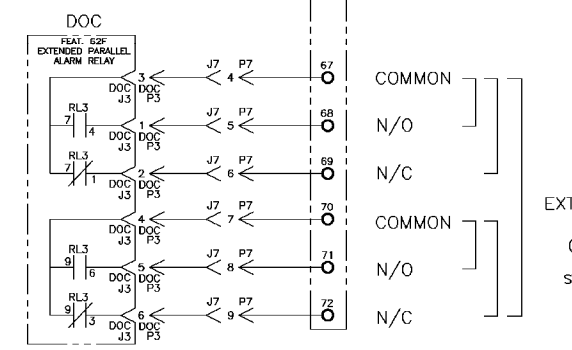

PROJECT NAME		WIRING DIAGRAM	
7000 SERIES (H7ACTS) GROUP 5 CONTROLS		DIAGRAM	
BY	DATE	MANUFACTURING TOLERANCES TO BE IN ACCORDANCE WITH ASCO PROCEDURE MP-1-003 FOR PLASTIC PARTS. SEE MP-1-055	ASSEM. REF. NO.
DRAWN BY	SDH	01/01	
CHECKED			
DRAFTING APPROVAL			
FINAL APPROVAL	SDH	01/01	
SCALE		ACAD FILE	
SIZE		DWS	
DRAWING NO.		DS713503	
CHANGE LETTER	A	EDN NO.	158293
		BY	
		APP.	
		DATE	
SUBSIDIARY DISTRIBUTION		COMPUTER GENERATED DRAWING	
AE	<input type="checkbox"/>	AN	<input type="checkbox"/>
AM	<input type="checkbox"/>	AP	<input type="checkbox"/>
AS	<input type="checkbox"/>	AT	<input type="checkbox"/>
AV	<input type="checkbox"/>	AW	<input type="checkbox"/>
AX	<input type="checkbox"/>	AY	<input type="checkbox"/>
BA	<input type="checkbox"/>	BB	<input type="checkbox"/>
BC	<input type="checkbox"/>	BD	<input type="checkbox"/>
BE	<input type="checkbox"/>	BF	<input type="checkbox"/>
BG	<input type="checkbox"/>	BH	<input type="checkbox"/>
BI	<input type="checkbox"/>	BJ	<input type="checkbox"/>
BK	<input type="checkbox"/>	BL	<input type="checkbox"/>
BM	<input type="checkbox"/>	BN	<input type="checkbox"/>
BO	<input type="checkbox"/>	BP	<input type="checkbox"/>
BQ	<input type="checkbox"/>	BR	<input type="checkbox"/>
BS	<input type="checkbox"/>	BT	<input type="checkbox"/>
BU	<input type="checkbox"/>	BV	<input type="checkbox"/>
BW	<input type="checkbox"/>	BX	<input type="checkbox"/>
BY	<input type="checkbox"/>	BZ	<input type="checkbox"/>
CA	<input type="checkbox"/>	CB	<input type="checkbox"/>
CC	<input type="checkbox"/>	CD	<input type="checkbox"/>
CE	<input type="checkbox"/>	CF	<input type="checkbox"/>
CG	<input type="checkbox"/>	CH	<input type="checkbox"/>
CI	<input type="checkbox"/>	CK	<input type="checkbox"/>
CL	<input type="checkbox"/>	CM	<input type="checkbox"/>
CN	<input type="checkbox"/>	CO	<input type="checkbox"/>
CP	<input type="checkbox"/>	CP	<input type="checkbox"/>
CQ	<input type="checkbox"/>	CR	<input type="checkbox"/>
CS	<input type="checkbox"/>	CT	<input type="checkbox"/>
CU	<input type="checkbox"/>	CV	<input type="checkbox"/>
CV	<input type="checkbox"/>	CW	<input type="checkbox"/>
CX	<input type="checkbox"/>	CX	<input type="checkbox"/>
CY	<input type="checkbox"/>	CY	<input type="checkbox"/>
CZ	<input type="checkbox"/>	CZ	<input type="checkbox"/>
DA	<input type="checkbox"/>	DA	<input type="checkbox"/>
DB	<input type="checkbox"/>	DB	<input type="checkbox"/>
DC	<input type="checkbox"/>	DC	<input type="checkbox"/>
DD	<input type="checkbox"/>	DD	<input type="checkbox"/>
DE	<input type="checkbox"/>	DE	<input type="checkbox"/>
DF	<input type="checkbox"/>	DF	<input type="checkbox"/>
DG	<input type="checkbox"/>	DG	<input type="checkbox"/>
DH	<input type="checkbox"/>	DH	<input type="checkbox"/>
DI	<input type="checkbox"/>	DI	<input type="checkbox"/>
DJ	<input type="checkbox"/>	DJ	<input type="checkbox"/>
DK	<input type="checkbox"/>	DK	<input type="checkbox"/>
DL	<input type="checkbox"/>	DL	<input type="checkbox"/>
DM	<input type="checkbox"/>	DM	<input type="checkbox"/>
DN	<input type="checkbox"/>	DN	<input type="checkbox"/>
DO	<input type="checkbox"/>	DO	<input type="checkbox"/>
DP	<input type="checkbox"/>	DP	<input type="checkbox"/>
DQ	<input type="checkbox"/>	DQ	<input type="checkbox"/>
DR	<input type="checkbox"/>	DR	<input type="checkbox"/>
DS	<input type="checkbox"/>	DS	<input type="checkbox"/>
DT	<input type="checkbox"/>	DT	<input type="checkbox"/>
DU	<input type="checkbox"/>	DU	<input type="checkbox"/>
DV	<input type="checkbox"/>	DV	<input type="checkbox"/>
DW	<input type="checkbox"/>	DW	<input type="checkbox"/>
DX	<input type="checkbox"/>	DX	<input type="checkbox"/>
DY	<input type="checkbox"/>	DY	<input type="checkbox"/>
DZ	<input type="checkbox"/>	DZ	<input type="checkbox"/>
EA	<input type="checkbox"/>	EA	<input type="checkbox"/>
EB	<input type="checkbox"/>	EB	<input type="checkbox"/>
EC	<input type="checkbox"/>	EC	<input type="checkbox"/>
ED	<input type="checkbox"/>	ED	<input type="checkbox"/>
EE	<input type="checkbox"/>	EE	<input type="checkbox"/>
EF	<input type="checkbox"/>	EF	<input type="checkbox"/>
EG	<input type="checkbox"/>	EG	<input type="checkbox"/>
EH	<input type="checkbox"/>	EH	<input type="checkbox"/>
EI	<input type="checkbox"/>	EI	<input type="checkbox"/>
EJ	<input type="checkbox"/>	EJ	<input type="checkbox"/>
EK	<input type="checkbox"/>	EK	<input type="checkbox"/>
EL	<input type="checkbox"/>	EL	<input type="checkbox"/>
EM	<input type="checkbox"/>	EM	<input type="checkbox"/>
EN	<input type="checkbox"/>	EN	<input type="checkbox"/>
EO	<input type="checkbox"/>	EO	<input type="checkbox"/>
EP	<input type="checkbox"/>	EP	<input type="checkbox"/>
EQ	<input type="checkbox"/>	EQ	<input type="checkbox"/>
ER	<input type="checkbox"/>	ER	<input type="checkbox"/>
ES	<input type="checkbox"/>	ES	<input type="checkbox"/>
ET	<input type="checkbox"/>	ET	<input type="checkbox"/>
EU	<input type="checkbox"/>	EU	<input type="checkbox"/>
EV	<input type="checkbox"/>	EV	<input type="checkbox"/>
EW	<input type="checkbox"/>	EW	<input type="checkbox"/>
EX	<input type="checkbox"/>	EX	<input type="checkbox"/>
EY	<input type="checkbox"/>	EY	<input type="checkbox"/>
EZ	<input type="checkbox"/>	EZ	<input type="checkbox"/>
FA	<input type="checkbox"/>	FA	<input type="checkbox"/>
FB	<input type="checkbox"/>	FB	<input type="checkbox"/>
FC	<input type="checkbox"/>	FC	<input type="checkbox"/>
FD	<input type="checkbox"/>	FD	<input type="checkbox"/>
FE	<input type="checkbox"/>	FE	<input type="checkbox"/>
FF	<input type="checkbox"/>	FF	<input type="checkbox"/>
FG	<input type="checkbox"/>	FG	<input type="checkbox"/>
FH	<input type="checkbox"/>	FH	<input type="checkbox"/>
FI	<input type="checkbox"/>	FI	<input type="checkbox"/>
FJ	<input type="checkbox"/>	FJ	<input type="checkbox"/>
FK	<input type="checkbox"/>	FK	<input type="checkbox"/>
FL	<input type="checkbox"/>	FL	<input type="checkbox"/>
FM	<input type="checkbox"/>	FM	<input type="checkbox"/>
FN	<input type="checkbox"/>	FN	<input type="checkbox"/>
FO	<input type="checkbox"/>	FO	<input type="checkbox"/>
FP	<input type="checkbox"/>	FP	<input type="checkbox"/>
FQ	<input type="checkbox"/>	FQ	<input type="checkbox"/>
FR	<input type="checkbox"/>	FR	<input type="checkbox"/>
FS	<input type="checkbox"/>	FS	<input type="checkbox"/>
FT	<input type="checkbox"/>	FT	<input type="checkbox"/>
FU	<input type="checkbox"/>	FU	<input type="checkbox"/>
FV	<input type="checkbox"/>	FV	<input type="checkbox"/>
FW	<input type="checkbox"/>	FW	<input type="checkbox"/>
FX	<input type="checkbox"/>	FX	<input type="checkbox"/>
FY	<input type="checkbox"/>	FY	<input type="checkbox"/>
FZ	<input type="checkbox"/>	FZ	<input type="checkbox"/>
GA	<input type="checkbox"/>	GA	<input type="checkbox"/>
GB	<input type="checkbox"/>	GB	<input type="checkbox"/>
GC	<input type="checkbox"/>	GC	<input type="checkbox"/>
GD	<input type="checkbox"/>	GD	<input type="checkbox"/>
GE	<input type="checkbox"/>	GE	<input type="checkbox"/>
GF	<input type="checkbox"/>	GF	<input type="checkbox"/>
GG	<input type="checkbox"/>	GG	<input type="checkbox"/>
GH	<input type="checkbox"/>	GH	<input type="checkbox"/>
GI	<input type="checkbox"/>	GI	<input type="checkbox"/>
GJ	<input type="checkbox"/>	GJ	<input type="checkbox"/>
GK	<input type="checkbox"/>	GK	<input type="checkbox"/>
GL	<input type="checkbox"/>	GL	<input type="checkbox"/>
GM	<input type="checkbox"/>	GM	<input type="checkbox"/>
GN	<input type="checkbox"/>	GN	<input type="checkbox"/>
GO	<input type="checkbox"/>	GO	<input type="checkbox"/>
GP	<input type="checkbox"/>	GP	<input type="checkbox"/>
GQ	<input type="checkbox"/>	GQ	<input type="checkbox"/>
GR	<input type="checkbox"/>	GR	<input type="checkbox"/>
GS	<input type="checkbox"/>	GS	<input type="checkbox"/>
GT	<input type="checkbox"/>	GT	<input type="checkbox"/>
GU	<input type="checkbox"/>	GU	<input type="checkbox"/>
GV	<input type="checkbox"/>	GV	<input type="checkbox"/>
GW	<input type="checkbox"/>	GW	<input type="checkbox"/>
GX	<input type="checkbox"/>	GX	<input type="checkbox"/>
GY	<input type="checkbox"/>	GY	<input type="checkbox"/>
GA	<input type="checkbox"/>	GA	<input type="checkbox"/>

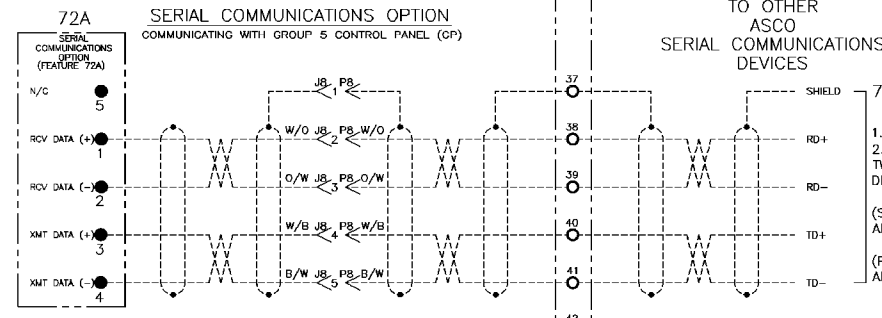
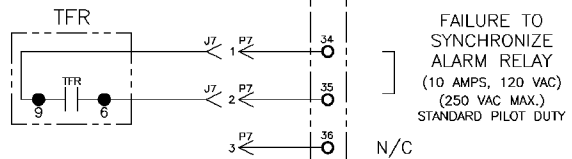
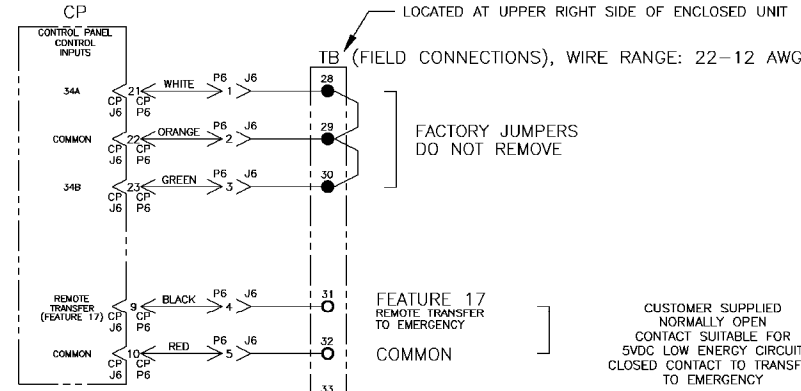
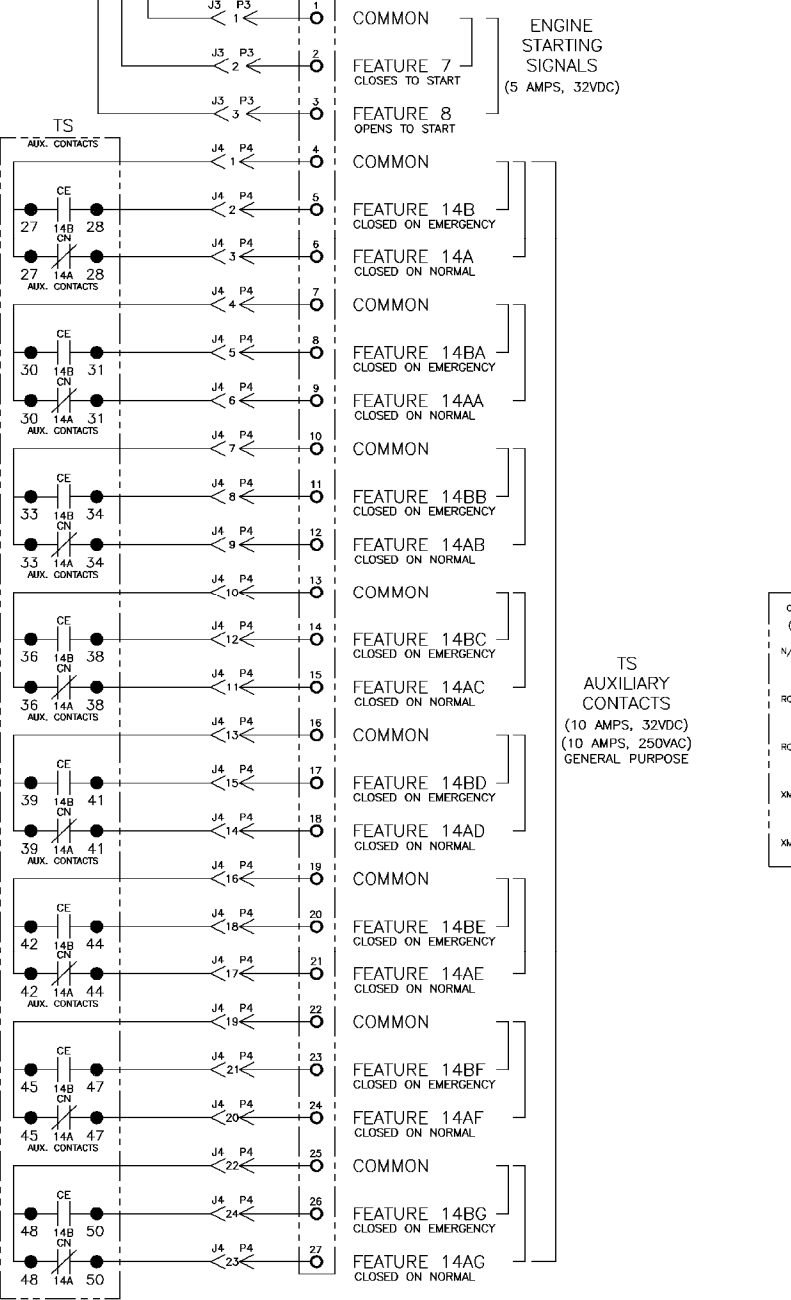
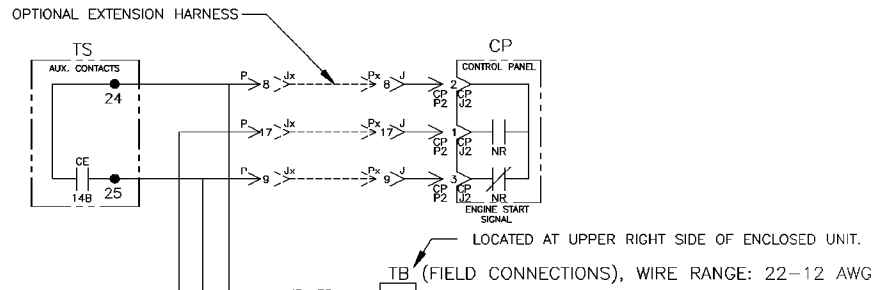

ASCO POWER TECHNOLOGIES, L.P.
FLORHAM PARK, NEW JERSEY 07932 U.S.A.

MAIN POWER POLES

TS OPERATOR CIRCUIT

EMERGENCY

NORMAL

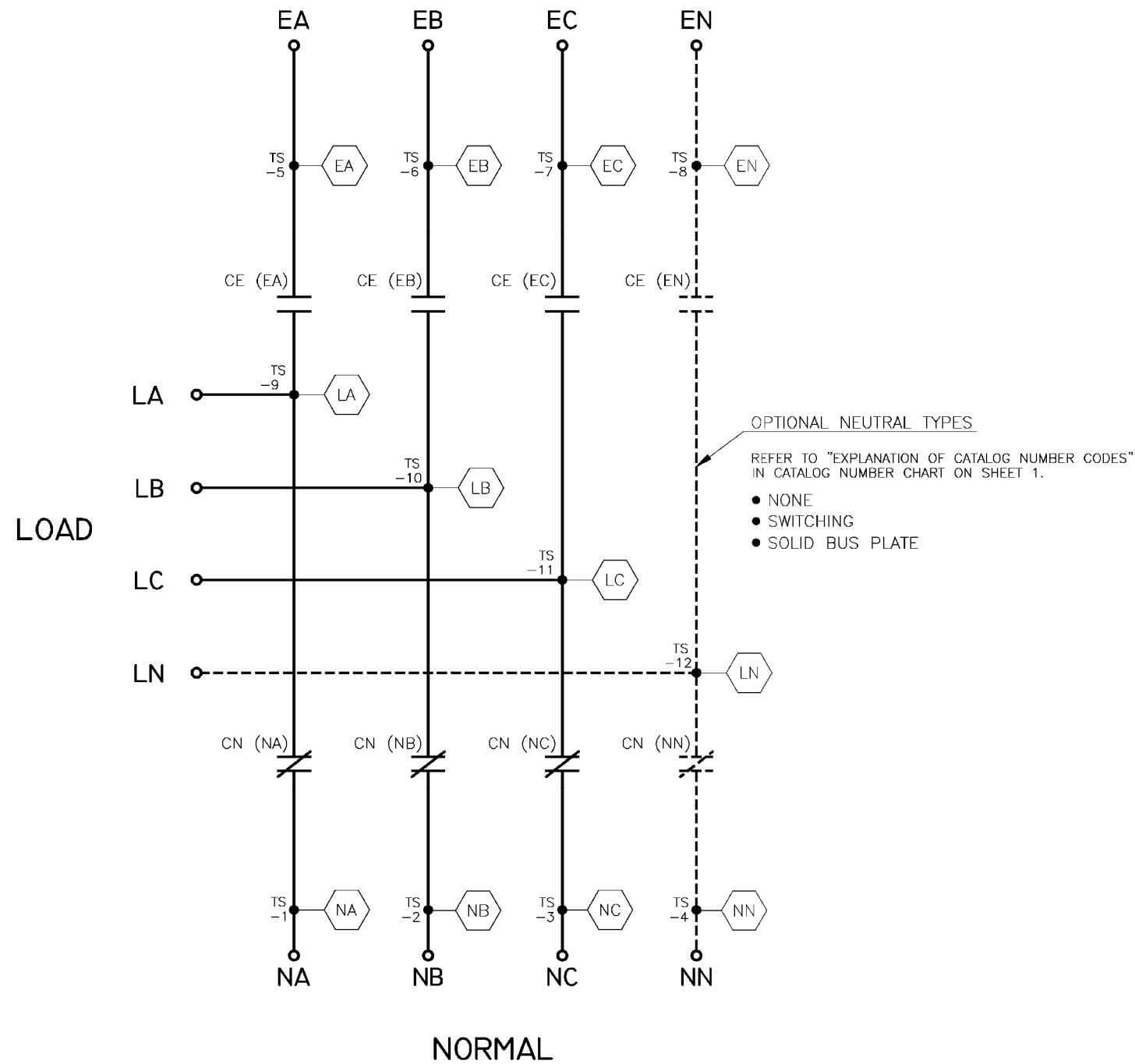

OPTIONAL NEUTRAL TYPES
 REFER TO "EXPLANATION OF CATALOG NUMBER CODES"
 IN CATALOG NUMBER CHART ON SHEET 1.

- NONE
- SWITCHING
- SOLID BUS PLATE

NOTE:
 ATS SHOWN CLOSED ON
 NORMAL SOURCE.

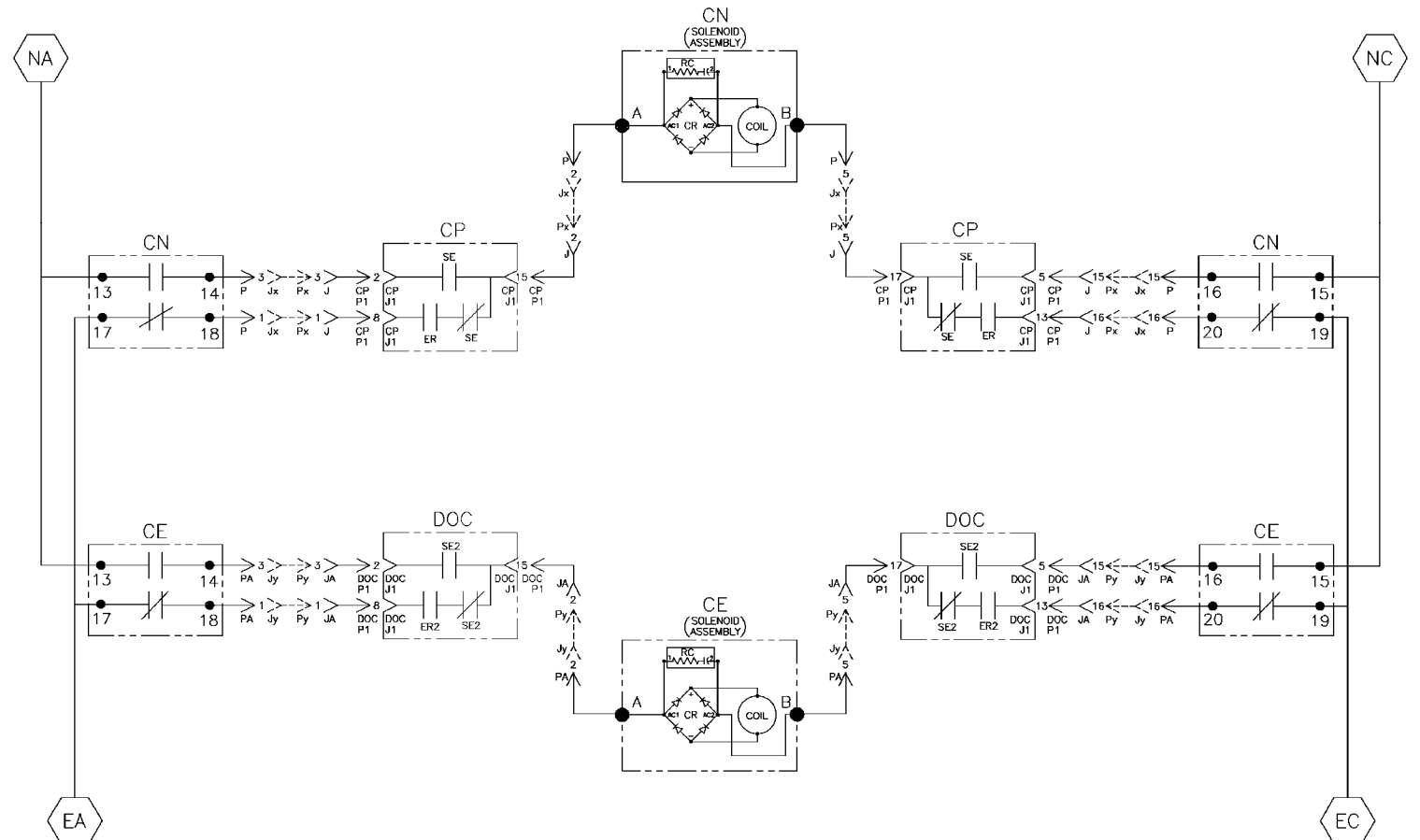

CN	SOLENOID POSITION			
	CLOSED BEFORE NORMAL TDC*	>	<	BEFORE OPEN
13-14				
15-16				
17-18				
19-20				

CE	SOLENOID POSITION			
	OPEN BEFORE TDC*	>	<	BEFORE CLOSED EMERG.
13-14				
15-16				
17-18				
19-20				

TDC (TOP DEAD CENTER)
 TRANSFER SWITCH TEST & ADJUSTMENT PROCEDURE
 SPECIFIES CONTROL CUT-OFF (CONTACT OPENING)
 SETTING.

PROJECT NAME: WIRING DIAGRAM 7000 SERIES (H7ACTS) GROUP 5 CONTROLS

MANUFACTURING TOLERANCES TO BE IN ACCORDANCE WITH ASQC PROCEDURE MP-1-003 FOR PLASTIC PARTS SEE MP-1-005

PROPERTY OF ASCO POWER TECHNOLOGIES. USE PERMITTED FOR OUR WORK ONLY. ALL RIGHTS OF DESIGN OR INVENTION ARE RESERVED.

ASCO POWER TECHNOLOGIES, L.P. FLORHAM PARK, NEW JERSEY 07932 U.S.A.

SCALE	ACAD	FILE
SIZE	DWG. NO.	DS713503
CHANGE LETTER	CON. NO.	158293
		SHEET 3 of 6

158293	BWM	WK	7/24/01
SEE ECN			
156547	SDH	SDH	01/01
ISSUE			
CHANGE LETTER	EDN NO.	BY	APP. DATE
SUBSIDIARY DISTRIBUTION			
AE	AN	AM	AL
CH	AV	AA	PS
AG	AP	AC	AS
COMPUTER GENERATED DRAWING			

EMERGENCY SOURCE CIRCUITS

ADDITIONAL CIRCUITS

EMERGENCY

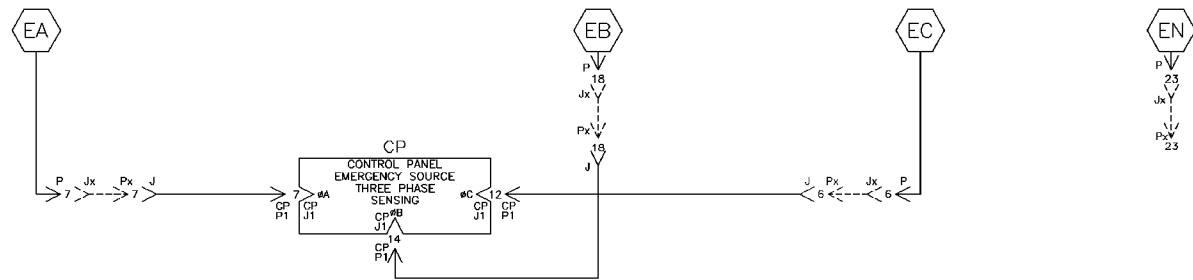

LOAD TERMINAL CIRCUITS

LOAD



NORMAL SOURCE CIRCUITS

NORMAL

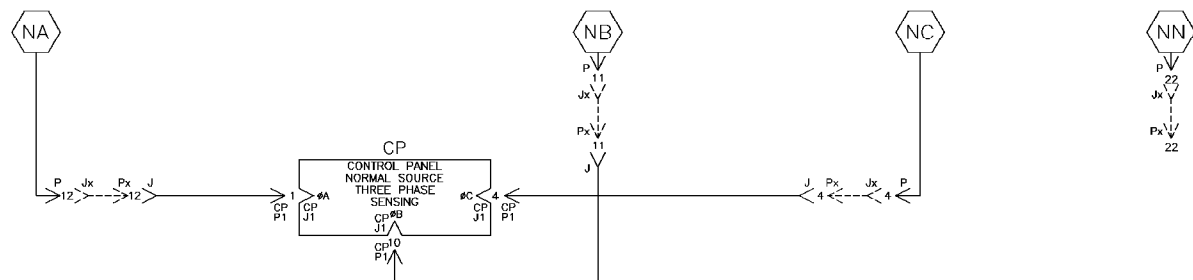

CONTROL CIRCUITS

SER2/ER2 CONTROL

TS POSITION SENSING

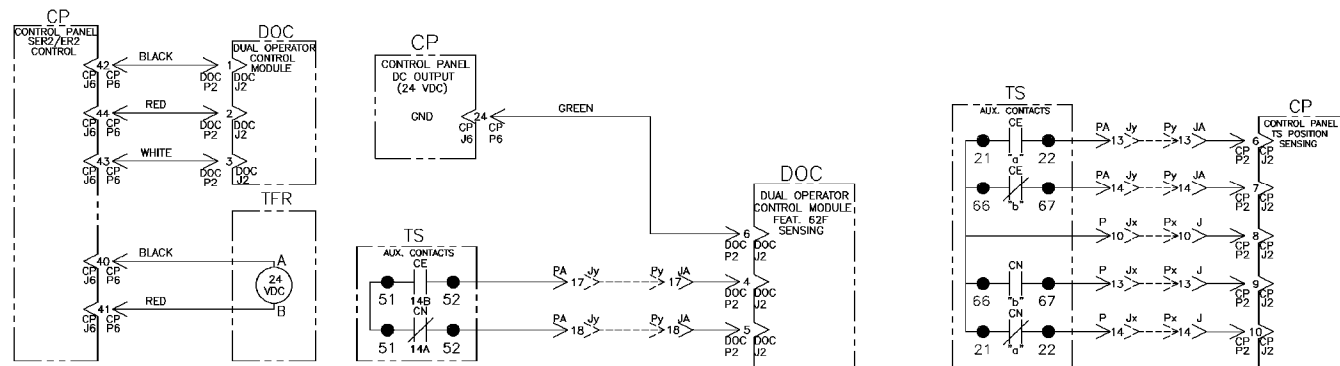

PROJECT NAME:		WIRING DIAGRAM		7000 SERIES (H7ACTS) GROUP 5 CONTROLS	
DRAWN BY	SDH	DATE	01/01	MANUFACTURING TOLERANCES TO BE IN ACCORDANCE WITH ASCO PROCEDURE MP-1-003. FOR PLASTIC PARTS SEE MP-1-355	ASSEM. REF. NO.
CHECKED		APPROVAL		PROPERTY OF ASCO POWER TECHNOLOGIES. USE PERMITTED FOR OUR WORK ONLY. ALL RIGHTS OF DESIGN OR INVENTION ARE RESERVED.	SCALE
DRAFTING APPROVAL		DATE	01/01	ASCO POWER TECHNOLOGIES, L.P. FLOHAM PARK, NEW JERSEY 07932 U.S.A.	ACAD FILE
FINAL APPROVAL		CHANGE LETTER	A	ECN NO.	158293
		BY		APP.	
		DATE			
SUBSIDIARY DISTRIBUTION		COMPUTER GENERATED DRAWING			
AE	<input type="checkbox"/>	AN	<input type="checkbox"/>	AW	<input type="checkbox"/>
AG	<input type="checkbox"/>	AP	<input type="checkbox"/>	AS	<input type="checkbox"/>
AL	<input type="checkbox"/>	AR	<input type="checkbox"/>	AT	<input type="checkbox"/>
AM	<input type="checkbox"/>	AO	<input type="checkbox"/>	AP	<input type="checkbox"/>
AN	<input type="checkbox"/>	AQ	<input type="checkbox"/>	AR	<input type="checkbox"/>
AO	<input type="checkbox"/>	AS	<input type="checkbox"/>	AT	<input type="checkbox"/>
AP	<input type="checkbox"/>	AT	<input type="checkbox"/>	AW	<input type="checkbox"/>
AS	<input type="checkbox"/>	AW	<input type="checkbox"/>	AX	<input type="checkbox"/>
AT	<input type="checkbox"/>	AX	<input type="checkbox"/>	AY	<input type="checkbox"/>
AW	<input type="checkbox"/>	AY	<input type="checkbox"/>	AZ	<input type="checkbox"/>
AX	<input type="checkbox"/>	AZ	<input type="checkbox"/>	BA	<input type="checkbox"/>
AY	<input type="checkbox"/>	BA	<input type="checkbox"/>	BB	<input type="checkbox"/>
AZ	<input type="checkbox"/>	BB	<input type="checkbox"/>	BC	<input type="checkbox"/>
BA	<input type="checkbox"/>	BC	<input type="checkbox"/>	BD	<input type="checkbox"/>
BB	<input type="checkbox"/>	BD	<input type="checkbox"/>	BE	<input type="checkbox"/>
BC	<input type="checkbox"/>	BE	<input type="checkbox"/>	BF	<input type="checkbox"/>
BD	<input type="checkbox"/>	BF	<input type="checkbox"/>	BG	<input type="checkbox"/>
BE	<input type="checkbox"/>	BG	<input type="checkbox"/>	BH	<input type="checkbox"/>
BF	<input type="checkbox"/>	BH	<input type="checkbox"/>	BI	<input type="checkbox"/>
BG	<input type="checkbox"/>	BI	<input type="checkbox"/>	BJ	<input type="checkbox"/>
BH	<input type="checkbox"/>	BJ	<input type="checkbox"/>	BK	<input type="checkbox"/>
BI	<input type="checkbox"/>	BK	<input type="checkbox"/>	BL	<input type="checkbox"/>
BJ	<input type="checkbox"/>	BL	<input type="checkbox"/>	BM	<input type="checkbox"/>
BK	<input type="checkbox"/>	BM	<input type="checkbox"/>	BN	<input type="checkbox"/>
BL	<input type="checkbox"/>	BN	<input type="checkbox"/>	BO	<input type="checkbox"/>
BM	<input type="checkbox"/>	BO	<input type="checkbox"/>	BP	<input type="checkbox"/>
BN	<input type="checkbox"/>	BP	<input type="checkbox"/>	BQ	<input type="checkbox"/>
BO	<input type="checkbox"/>	BQ	<input type="checkbox"/>	BR	<input type="checkbox"/>
BP	<input type="checkbox"/>	BR	<input type="checkbox"/>	BS	<input type="checkbox"/>
BQ	<input type="checkbox"/>	BS	<input type="checkbox"/>	BT	<input type="checkbox"/>
BR	<input type="checkbox"/>	BT	<input type="checkbox"/>	BU	<input type="checkbox"/>
BS	<input type="checkbox"/>	BU	<input type="checkbox"/>	BV	<input type="checkbox"/>
BT	<input type="checkbox"/>	BV	<input type="checkbox"/>	BW	<input type="checkbox"/>
BU	<input type="checkbox"/>	BW	<input type="checkbox"/>	BX	<input type="checkbox"/>
BV	<input type="checkbox"/>	BX	<input type="checkbox"/>	BY	<input type="checkbox"/>
BW	<input type="checkbox"/>	BY	<input type="checkbox"/>	BZ	<input type="checkbox"/>
BX	<input type="checkbox"/>	BZ	<input type="checkbox"/>	CA	<input type="checkbox"/>
BY	<input type="checkbox"/>	CA	<input type="checkbox"/>	CB	<input type="checkbox"/>
BZ	<input type="checkbox"/>	CB	<input type="checkbox"/>	CC	<input type="checkbox"/>
CA	<input type="checkbox"/>	CC	<input type="checkbox"/>	CD	<input type="checkbox"/>
CB	<input type="checkbox"/>	CD	<input type="checkbox"/>	CE	<input type="checkbox"/>
CC	<input type="checkbox"/>	CE	<input type="checkbox"/>	CF	<input type="checkbox"/>
CD	<input type="checkbox"/>	CF	<input type="checkbox"/>	CG	<input type="checkbox"/>
CE	<input type="checkbox"/>	CG	<input type="checkbox"/>	CH	<input type="checkbox"/>
CF	<input type="checkbox"/>	CH	<input type="checkbox"/>	CI	<input type="checkbox"/>
CG	<input type="checkbox"/>	CI	<input type="checkbox"/>	CJ	<input type="checkbox"/>
CH	<input type="checkbox"/>	CJ	<input type="checkbox"/>	CK	<input type="checkbox"/>
CI	<input type="checkbox"/>	CK	<input type="checkbox"/>	CL	<input type="checkbox"/>
CJ	<input type="checkbox"/>	CL	<input type="checkbox"/>	CM	<input type="checkbox"/>
CK	<input type="checkbox"/>	CM	<input type="checkbox"/>	CN	<input type="checkbox"/>
CL	<input type="checkbox"/>	CN	<input type="checkbox"/>	CO	<input type="checkbox"/>
CM	<input type="checkbox"/>	CO	<input type="checkbox"/>	CP	<input type="checkbox"/>
CN	<input type="checkbox"/>	CP	<input type="checkbox"/>	CQ	<input type="checkbox"/>
CO	<input type="checkbox"/>	CQ	<input type="checkbox"/>	CR	<input type="checkbox"/>
CP	<input type="checkbox"/>	CR	<input type="checkbox"/>	CS	<input type="checkbox"/>
CQ	<input type="checkbox"/>	CS	<input type="checkbox"/>	CT	<input type="checkbox"/>
CR	<input type="checkbox"/>	CT	<input type="checkbox"/>	CU	<input type="checkbox"/>
CS	<input type="checkbox"/>	CU	<input type="checkbox"/>	CV	<input type="checkbox"/>
CT	<input type="checkbox"/>	CV	<input type="checkbox"/>	CW	<input type="checkbox"/>
CU	<input type="checkbox"/>	CW	<input type="checkbox"/>	CX	<input type="checkbox"/>
CV	<input type="checkbox"/>	CX	<input type="checkbox"/>	CY	<input type="checkbox"/>
CW	<input type="checkbox"/>	CY	<input type="checkbox"/>	CZ	<input type="checkbox"/>
CX	<input type="checkbox"/>	CZ	<input type="checkbox"/>	DA	<input type="checkbox"/>
CY	<input type="checkbox"/>	DA	<input type="checkbox"/>	DB	<input type="checkbox"/>
CZ	<input type="checkbox"/>	DB	<input type="checkbox"/>	DC	<input type="checkbox"/>
DA	<input type="checkbox"/>	DC	<input type="checkbox"/>	DD	<input type="checkbox"/>
DB	<input type="checkbox"/>	DD	<input type="checkbox"/>	DE	<input type="checkbox"/>
DC	<input type="checkbox"/>	DE	<input type="checkbox"/>	DF	<input type="checkbox"/>
DD	<input type="checkbox"/>	DF	<input type="checkbox"/>	DG	<input type="checkbox"/>
DE	<input type="checkbox"/>	DG	<input type="checkbox"/>	DH	<input type="checkbox"/>
DF	<input type="checkbox"/>	DH	<input type="checkbox"/>	DI	<input type="checkbox"/>
DG	<input type="checkbox"/>	DI	<input type="checkbox"/>	DJ	<input type="checkbox"/>
DH	<input type="checkbox"/>	DJ	<input type="checkbox"/>	DK	<input type="checkbox"/>
DI	<input type="checkbox"/>	DK	<input type="checkbox"/>	DL	<input type="checkbox"/>
DJ	<input type="checkbox"/>	DL	<input type="checkbox"/>	DM	<input type="checkbox"/>
DK	<input type="checkbox"/>	DM	<input type="checkbox"/>	DN	<input type="checkbox"/>
DL	<input type="checkbox"/>	DN	<input type="checkbox"/>	DO	<input type="checkbox"/>
DM	<input type="checkbox"/>	DO	<input type="checkbox"/>	DP	<input type="checkbox"/>
DN	<input type="checkbox"/>	DP	<input type="checkbox"/>	DQ	<input type="checkbox"/>
DO	<input type="checkbox"/>	DQ	<input type="checkbox"/>	DR	<input type="checkbox"/>
DP	<input type="checkbox"/>	DR	<input type="checkbox"/>	DS	<input type="checkbox"/>
DQ	<input type="checkbox"/>	DS	<input type="checkbox"/>	DT	<input type="checkbox"/>
DR	<input type="checkbox"/>	DT	<input type="checkbox"/>	DU	<input type="checkbox"/>
DS	<input type="checkbox"/>	DU	<input type="checkbox"/>	DV	<input type="checkbox"/>
DT	<input type="checkbox"/>	DV	<input type="checkbox"/>	DW	<input type="checkbox"/>
DU	<input type="checkbox"/>	DW	<input type="checkbox"/>	DX	<input type="checkbox"/>
DV	<input type="checkbox"/>	DX	<input type="checkbox"/>	DY	<input type="checkbox"/>
DW	<input type="checkbox"/>	DY	<input type="checkbox"/>	DZ	<input type="checkbox"/>
DX	<input type="checkbox"/>	DZ	<input type="checkbox"/>	EA	<input type="checkbox"/>
DY	<input type="checkbox"/>	EA	<input type="checkbox"/>	EB	<input type="checkbox"/>
DZ	<input type="checkbox"/>	EB	<input type="checkbox"/>	EC	<input type="checkbox"/>
EA	<input type="checkbox"/>	EC	<input type="checkbox"/>	ED	<input type="checkbox"/>
EB	<input type="checkbox"/>	ED	<input type="checkbox"/>	EE	<input type="checkbox"/>
EC	<input type="checkbox"/>	EE	<input type="checkbox"/>	EF	<input type="checkbox"/>
ED	<input type="checkbox"/>	EF	<input type="checkbox"/>	EG	<input type="checkbox"/>
EE	<input type="checkbox"/>	EG	<input type="checkbox"/>	EH	<input type="checkbox"/>
EF	<input type="checkbox"/>	EH	<input type="checkbox"/>	EI	<input type="checkbox"/>
EG	<input type="checkbox"/>	EI	<input type="checkbox"/>	EJ	<input type="checkbox"/>
EH	<input type="checkbox"/>	EJ	<input type="checkbox"/>	EK	<input type="checkbox"/>
EI	<input type="checkbox"/>	EK	<input type="checkbox"/>	EL	<input type="checkbox"/>
EJ	<input type="checkbox"/>	EL	<input type="checkbox"/>	EM	<input type="checkbox"/>
EK	<input type="checkbox"/>	EM	<input type="checkbox"/>	EN	<input type="checkbox"/>
EL	<input type="checkbox"/>	EN	<input type="checkbox"/>	EO	<input type="checkbox"/>
EM	<input type="checkbox"/>	EO	<input type="checkbox"/>	EP	<input type="checkbox"/>
EN	<input type="checkbox"/>	EP	<input type="checkbox"/>	EQ	<input type="checkbox"/>
EO	<input type="checkbox"/>	EQ	<input type="checkbox"/>	ER	<input type="checkbox"/>
EP	<input type="checkbox"/>	ER	<input type="checkbox"/>	ES	<input type="checkbox"/>
EQ	<input type="checkbox"/>	ES	<input type="checkbox"/>	ET	<input type="checkbox"/>
ER	<input type="checkbox"/>	ET	<input type="checkbox"/>	EU	<input type="checkbox"/>
ES	<input type="checkbox"/>	EU	<input type="checkbox"/>	EV	<input type="checkbox"/>
ET	<input type="checkbox"/>	EV	<input type="checkbox"/>	EW	<input type="checkbox"/>
EU	<input type="checkbox"/>	EW	<input type="checkbox"/>	EX	<input type="checkbox"/>
EV	<input type="checkbox"/>	EX	<input type="checkbox"/>	EY	<input type="checkbox"/>
EW	<input type="checkbox"/>	EY	<input type="checkbox"/>	EZ	<input type="checkbox"/>
EX	<input type="checkbox"/>	EZ	<input type="checkbox"/>	FA	<input type="checkbox"/>
EY	<input type="checkbox"/>	FA	<input type="checkbox"/>	FB	<input type="checkbox"/>
EZ	<input type="checkbox"/>	FB	<input type="checkbox"/>	FC	<input type="checkbox"/>
FA	<input type="checkbox"/>	FC	<input type="checkbox"/>	FD	<input type="checkbox"/>
FB	<input type="checkbox"/>	FD	<input type="checkbox"/>	FE	<input type="checkbox"/>
FC	<input type="checkbox"/>	FE	<input type="checkbox"/>	FF	<input type="checkbox"/>
FD	<input type="checkbox"/>	FF	<input type="checkbox"/>	FG	<input type="checkbox"/>
FE	<input type="checkbox"/>	FG	<input type="checkbox"/>	FH	<input type="checkbox"/>
FF	<input type="checkbox"/>	FH	<input type="checkbox"/>	FI	<input type="checkbox"/>
FG	<input type="checkbox"/>	FI	<input type="checkbox"/>	FJ	<input type="checkbox"/>
FH	<input type="checkbox"/>	FJ	<input type="checkbox"/>	FK	<input type="checkbox"/>
FI	<input type="checkbox"/>	FK	<input type="checkbox"/>	FL	<input type="checkbox"/>
FJ	<input type="checkbox"/>	FL	<input type="checkbox"/>	FM	<input type="checkbox"/>
FK	<input type="checkbox"/>	FM	<input type="checkbox"/>	FN	<input type="checkbox"/>
FL	<input type="checkbox"/>	FN	<input type="checkbox"/>	FO	<input type="checkbox"/>
FM	<input type="checkbox"/>	FO	<input type="checkbox"/>	FP	<input type="checkbox"/>
FN	<input type="checkbox"/>	FP	<input type="checkbox"/>	FQ	<input type="checkbox"/>
FO	<input type="checkbox"/>	FQ	<input type="checkbox"/>	FR	<input type="checkbox"/>
FP	<input type="checkbox"/>	FR	<input type="checkbox"/>	FS	<input type="checkbox"/>
FQ	<input type="checkbox"/>	FS	<input type="checkbox"/>	FT	<input type="checkbox"/>
FR	<input type="checkbox"/>	FT	<input type="checkbox"/>	FU	<input type="checkbox"/>
FS	<input type="checkbox"/>	FU	<input type="checkbox"/>	FV	<input type="checkbox"/>
FT	<input type="checkbox"/>	FV	<input type="checkbox"/>	FW	<input type="checkbox"/>
FU	<input type="checkbox"/>	FW	<input type="checkbox"/>	FX	<input type="checkbox"/>
FV	<input type="checkbox"/>	FX	<input type="checkbox"/>	FY	<input type="checkbox"/>
FW	<input type="checkbox"/>	FY	<input type="checkbox"/>	FZ	<input type="checkbox"/>
FX	<input type="checkbox"/>	FZ	<input type="checkbox"/>	GA	<input type="checkbox"/>
FY	<input type="checkbox"/>	GA	<input type="checkbox"/>	GB	<input type="checkbox"/>
FZ	<input type="checkbox"/>	GB	<input type="checkbox"/>	GC	<input type="checkbox"/>
GA	<input type="checkbox"/>	GC	<input type="checkbox"/>	GD	<input type="checkbox"/>
GB	<input type="checkbox"/>	GD	<input type="checkbox"/>	GE	<input type="checkbox"/>
GC	<input type="checkbox"/>	GE	<input type="checkbox"/>	GF	<input type="checkbox"/>
GD	<input type="checkbox"/>	GF	<input type="checkbox"/>	GG	<input type="checkbox"/>
GE	<input type="checkbox"/>	GG	<input type="checkbox"/>	GH	<input type="checkbox"/>
GF	<input type="checkbox"/>	GH	<input type="checkbox"/>	GI	<input type="checkbox"/>
GG	<input type="checkbox"/>	GI	<input type="checkbox"/>	GJ	<input type="checkbox"/>
GH	<input type="checkbox"/>	GJ	<input type="checkbox"/>	GK	<input type="checkbox"/>
GI	<input type="checkbox"/>	GK	<input type="checkbox"/>	GL	<input type="checkbox"/>
GJ	<input type="checkbox"/>	GL	<input type="checkbox"/>	GM	<input type="checkbox"/>
GK	<input type="checkbox"/>	GM	<input type="checkbox"/>	GN	<input type="checkbox"/>
GL	<input type="checkbox"/>	GN	<input type="checkbox"/>	GO	<input type="checkbox"/>
GM	<input type="checkbox"/>	GO	<input type="checkbox"/>	GP	<input type="checkbox"/>
GN	<input type="checkbox"/>	GP	<input type="checkbox"/>	GQ	<input type="checkbox"/>
GO	<input type="checkbox"/>	GQ	<input type="checkbox"/>	GR	<input type="checkbox"/>
GP	<input type="checkbox"/>	GR	<input type="checkbox"/>	GS	<input type="checkbox"/>
GQ	<input type="checkbox"/>	GS	<input type="checkbox"/>	GT	<input type="checkbox"/>
GR	<input type="checkbox"/>	GT	<input type="checkbox"/>	GU	<input type="checkbox"/>
GS	<input type="checkbox"/>	GU	<input type="checkbox"/>	GV	<input type="checkbox"/>
GT	<input type="checkbox"/>	GV	<input type="checkbox"/>	GW	<input type="checkbox"/>
GU	<input type="checkbox"/>	GW	<input type="checkbox"/>	GX	<input type="checkbox"/>
GV	<input type="checkbox"/>	GX	<input type="checkbox"/>	GY	<input type="checkbox"/>
GW	<input type="checkbox"/>	GY	<input type="checkbox"/>	GA	<input type="checkbox"/>
GX	<input type="checkbox"/>	GA	<input type="checkbox"/>	GB	<input type="checkbox"/>
GY	<input type="checkbox"/>	GB	<input type="checkbox"/>	GC	<input type="checkbox"/>
GA	<input type="checkbox"/>	GC	<input type="checkbox"/>	GD	<input type="checkbox"/>
GB	<input type="checkbox"/>	GD	<input type="checkbox"/>	GE	<input type="checkbox"/>
GC	<input type="checkbox"/>	GE	<input type="checkbox"/>	GF	<input type="checkbox"/>
GD	<input type="checkbox"/>	GF	<input type="checkbox"/>	GG	<input type="checkbox"/>
GE	<input type="checkbox"/>	GG	<input type="checkbox"/>	GH	<input type="checkbox"/>
GF	<input type="checkbox"/>	GH	<input type="checkbox"/>	GI	<input type="checkbox"/>
GG	<input type="checkbox"/>	GI	<input type="checkbox"/>	GJ	<input type="checkbox"/>
GH	<input type="checkbox"/>	GJ	<input type="checkbox"/>	GK	<input type="checkbox"/>
GI	<input type="checkbox"/>	GK	<input type="checkbox"/>	GL	<input type="checkbox"/>
GJ	<input type="checkbox"/>	GL	<input type="checkbox"/>	GM	<input type="checkbox"/>
GK	<input type="checkbox"/>	GM	<input type="checkbox"/>	GN	<input type="checkbox"/>
GL	<input type="checkbox"/>	GN	<input type="checkbox"/>	GO	<input type="checkbox"/>
GM	<input type="checkbox"/>	GO	<input type="checkbox"/>	GP	<input type="checkbox"/>
GN	<input type="checkbox"/>	GP	<input type="checkbox"/>	GQ	<input type="checkbox"/>
GO	<input type="checkbox"/>	GQ	<input type="checkbox"/>	GR	<input type="checkbox"/>
GP</					

PHYSICAL DIAGRAM

ENCLOSURE

DOOR (INSIDE)

TS (TRANSFER SWITCH)
VIEW FROM INSIDE FRONT

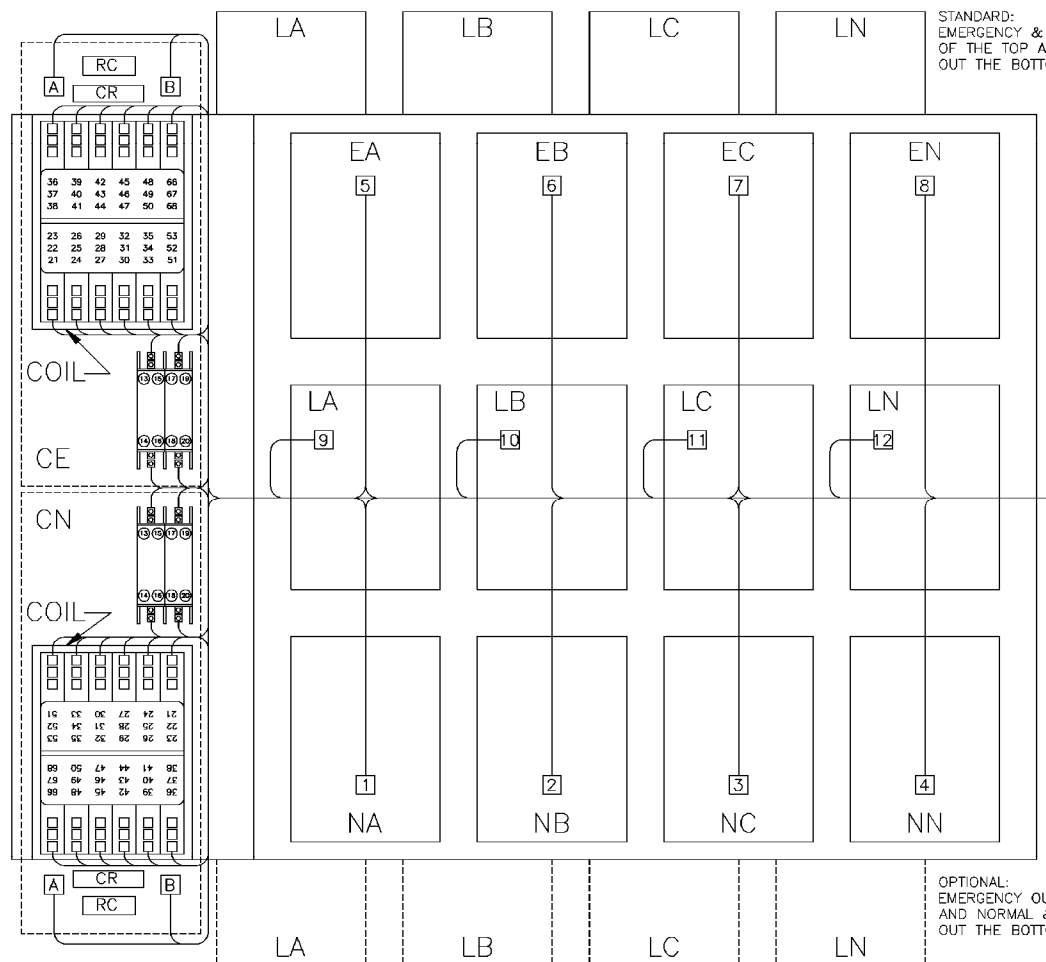

STANDARD:
EMERGENCY & LOAD OUT
OF THE TOP AND NORMAL
OUT THE BOTTOM.

OPTIONAL:
EMERGENCY OUT OF THE TOP
AND NORMAL & LOAD
OUT THE BOTTOM.

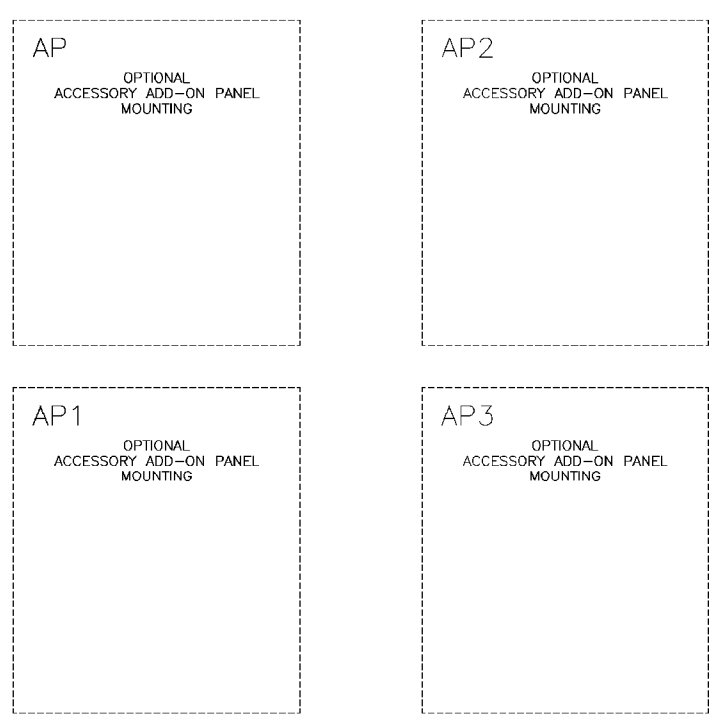
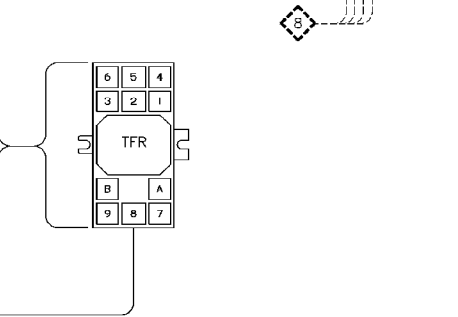
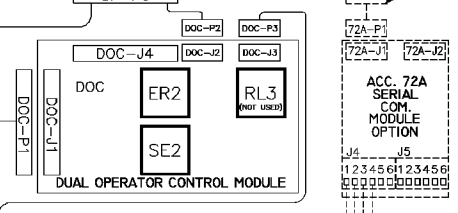
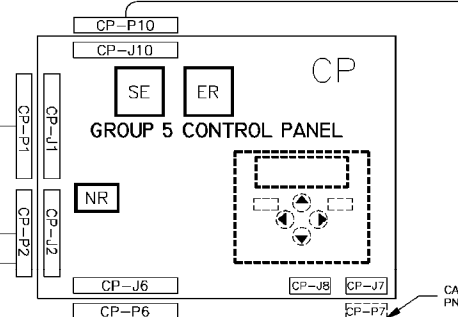
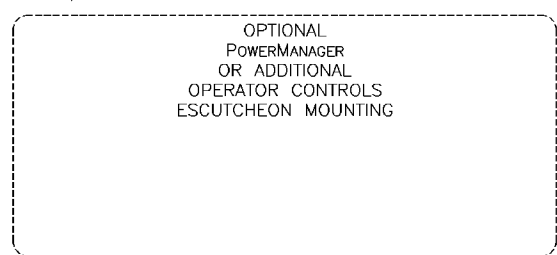
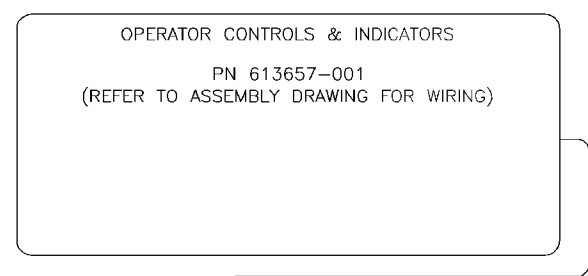
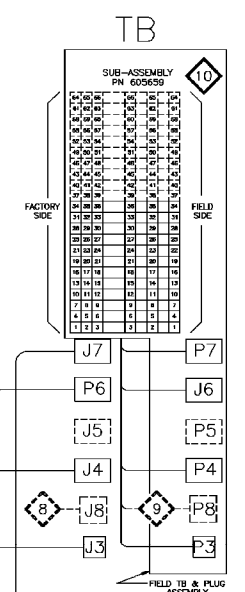

PROJECT NAME		WIRING DIAGRAM		7000 SERIES (H7ACTS) GROUP 5 CONTROLS	
BY	DATE	MANUFACTURING TOLERANCES TO BE IN ACCORDANCE WITH ASCO PROCEDURE MP-1-003 FOR PLASTIC PARTS. SEE MP-1-055	ASSEM. REF. NO.	SCALE	FILE
DRAWN BY	SDH	01/01		ACAD	
CHECKED					
DRAFTING APPROVAL					
FINAL APPROVAL					
PROPERTY OF ASCO POWER TECHNOLOGIES. USE PERMITTED FOR OUR WORK ONLY. ALL RIGHTS OF DESIGN OR INVENTION ARE RESERVED.		ASCO POWER TECHNOLOGIES, L.P. FLORHAM PARK, NEW JERSEY 07932 U.S.A.		COMPUTER GENERATED DRAWING	
SIZE		DWC. NO.		DS713503	
CHANGE LETTER	A	ISS. NO.	158293	SHEET	5 OF 6

158293	BWM	WK	7/24/01
SEE ECN			
156547	SDH	SDH	01/01
ISSUE			
CHANGE LETTER	EDN NO.	BY	APP.
SUBSIDIARY DISTRIBUTION			
AE	AN	AM	AL
CH	AV	AA	PS
AG	AP	AC	AS
THIRD ANGLE PROJECTION			

WIRE RUN LISTING

HARNESS LOCATOR 1 HARNESS 713081 (P,PA,J3,J4) MAIN TS CLR AWC 16. Table listing wire numbers and descriptions for harness 713081, including items like P-1,CN-18, P-2,CN-A, etc.

HARNESS LOCATOR 2 HARNESS 483763 (J,CP-P1,CP-P2) CONTROL PANEL CLR AWC 16. Table listing wire numbers and descriptions for harness 483763, including items like J-1,CP-P1-8, J-2,CP-P1-15, etc.

HARNESS LOCATOR 5 HARNESS 309320-005 OPTIONAL 8 IN. EXTENSION HARNESS CLR AWC 16. Table listing wire numbers and descriptions for harness 309320-005, including items like Jy-1,Py-1, Jy-2,Py-2, etc.

HARNESS LOCATOR 8 HARNESS 605454-005 (J8) OPTIONAL SERIAL I/O CLR AWC 22 (2 COND). Table listing wire numbers and descriptions for harness 605454-005, including items like J8-1,SHLD, J8-2,72A-1, etc.

WIRE No. ADDITIONAL WIRING CLR AWC. Table listing additional wiring details, including items like CP-P6-40,IFR-A, CP-P6-41,IFR-B, etc.

HARNESS LOCATOR 3 HARNESS 309320-005 OPTIONAL 8" EXTENSION HARNESS CLR AWC 16. Table listing wire numbers and descriptions for harness 309320-005, including items like Jx-1,Px-1, Jx-2,Px-2, etc.

HARNESS LOCATOR 6 HARNESS 619510-005 (P6) FIELD INPUTS CLR AWC 22 (12 COND). Table listing wire numbers and descriptions for harness 619510-005, including items like P6-1,CP-P6-21, P6-2,CP-P6-22, etc.

HARNESS LOCATOR 9 HARNESS 605454-007 (P8,TB) OPTIONAL SERIAL I/O CLR AWC 22 (4 COND). Table listing wire numbers and descriptions for harness 605454-007, including items like P8-1,TB-37, P8-2,TB-38, etc.

HARNESS LOCATOR 4 HARNESS 619385 (JA,CP-P2,DOC-P1) CONTROL MODULE CLR AWC 16. Table listing wire numbers and descriptions for harness 619385, including items like JA-1,DOC-P1-8, JA-2,DOC-P1-15, etc.

HARNESS LOCATOR 7 HARNESS (J7) OPTIONAL FIELD OUTPUTS CLR AWC 16. Table listing wire numbers and descriptions for harness (J7) OPTIONAL FIELD OUTPUTS, including items like J7-1,IFR-9, J7-2,IFR-6, etc.

PROJECT NAME: WIRING DIAGRAM 7000 SERIES (H7ACTS) GROUP 5 CONTROLS. Includes drawing information, scale, date, and manufacturer details (ASCO POWER TECHNOLOGIES, L.P.).