

THREE PHASE WIRING FOR ASCO 7000 SERIES MANUALLY OPERATED TRANSFER SWITCH TYPE E7MTS RATED 260-400 AMPERES

FEATURES, OPERATION, & NOTES

SIGNALS & AUXILIARIES

A. FEATURE 14A & 14B – TRANSFER SWITCH AUXILIARY POSITION INDICATING CONTACTS. ONE (1) FORM A CONTACTS TO INDICATE CONNECTION OF THE TRANSFER SWITCH TO NORMAL (14A) AND ONE (1) FORM A CONTACTS TO INDICATE CONNECTION OF THE TRANSFER SWITCH TO EMERGENCY (14B). CONTACTS CONNECTED TO THE FIELD CONNECTIONS TERMINAL BLOCK (TB). CONTACTS RATED 10 AMPS, 32 VDC, 250 VAC.

INDICATORS

B. FEATURES 9A & 9B – TRANSFER SWITCH POSITION INDICATORS.
 FEATURE 9A: TRANSFER SWITCH CLOSED ON NORMAL (GREEN LED)
 FEATURE 9B: TRANSFER SWITCH CLOSED ON EMERGENCY (RED LED)

C. FEATURES 9C & 9D – SOURCE ACCEPTANCE INDICATORS.
 FEATURE 9C: NORMAL SOURCE AVAILABLE (GREEN LED)
 FEATURE 9D: EMERGENCY SOURCE AVAILABLE (RED LED)

OPERATION

260-400 AMPS:
 PULL HANDLE UP FOR TRANSFER TO NORMAL.
 PUSH HANDLE DOWN FOR TRANSFER TO EMERGENCY.
 HANDLE WILL RETURN TO INTERMEDIATE POSITION WHEN RELEASED.
 HANDLE DOES NOT INDICATE SWITCH POSITION.

CAUTION:

OPERATE SWITCH ONLY WITH THE ENCLOSURE DOOR CLOSED.

GENERAL NOTES

1. SWITCH SHOWN DE-ENERGIZED AND CONNECTED TO THE NORMAL SOURCE.
2. DEVICE SYMBOLS AND DESIGNATIONS ARE IN ACCORDANCE WITH NEMA PUBLICATION ICS 1-1983, PART 1-101A.
3. ALL WIRING IS #16 AWG, TINNED, STRANDED COPPER UNLESS OTHERWISE INDICATED.
4. ○ ON TERMINAL BLOCKS INDICATES AVAILABLE FIELD CONNECTION POINT.
5. ● ON TERMINAL BLOCKS INDICATES FACTORY CONNECTION POINT.
6. CONTROL AND ACCESSORY WIRING IS ROUTED IN ACCORDANCE WITH ASCO ASSEMBLY PROCEDURE GS451261.
7. AN OPERATOR'S MANUAL IS FURNISHED WITH EACH TRANSFER SWITCH. REFER TO THIS PUBLICATION PRIOR TO INSTALLATION AND OPERATION OF THE UNIT.

BASE CATALOG NUMBER				CATALOG NUMBER SUFFIXES				EXPLANATION OF CATALOG NUMBER CODES						
CATALOG TYPE	NEUTRAL TYPE	PHASE POLES	AMPS	VOLT CODE	CONTROLLER	OPTIONAL ACCESSORY	ENCLOSURE CODE	NEUTRAL TYPE		VOLTAGE CODES		ENCLOSURE CODES		
								CODE	DESCRIPTION	CODE	NOMINAL VOLTAGE	CODE	TYPE	DESCRIPTION
E7MTS	A	3	260 400	BLANK		X	C E F G H J K L M N P Q	BLANK	NONE	BLANK	BLANK	BLANK	1	OPEN TYPE (NO ENCLOSURE)
	C							C	SOLID			E	2	GENERAL PURPOSE, INDOOR
								F	OVERLAPPING			G	3R	INDOOR, WATER & DUST RESISTANT
								H				J	4	INDOOR, RAINPROOF, SLEET & ICE RESISTANT
								K				L	4X	INDOOR/OUTDOOR, WATERTIGHT & DUSTTIGHT
								M				N	4X	TYPE 4 PLUS CORROSION RESISTANCE (STAINLESS STEEL)
								P				O	7	TYPE 4 PLUS CORROSION RESISTANCE (FIBERGLASS)
								Q					12	EXPLOSION PROOF
														INDOOR, INDUSTRIAL ENVIRONMENTS, OILTIGHT & DUSTTIGHT
														(SECURE ENCLOSURES)
														OUTDOOR, RAINPROOF, SLEET & ICE RESISTANT
														INDOOR/OUTDOOR, WATERTIGHT & DUSTTIGHT
														TYPE 4 PLUS CORROSION RESISTANCE (STAINLESS STEEL)
														INDOOR, INDUSTRIAL ENVIRONMENTS, OILTIGHT & DUSTTIGHT

CATALOG NUMBER _____
 CERTIFIED TO
ASCO® S.O. _____
 BY _____
 DATE _____

FORM REV E

PROJECT NAME: _____

WIRING _____ DIAGRAM _____

7000 SERIES (7MTS)
 MANUALLY OPERATED TS

THIRD ANGLE PROJECTION

DRAWN BY	CT	DATE	03/01/01	MANUFACTURING TOLERANCES TO BE IN ACCORDANCE WITH ASCO PROCEDURE MP-I-003. FOR PLASTIC PARTS SEE MP-I-055	ASSEM. REF. NO.
CHECKED	BK	DATE	3/20/01	PROPERTY OF ASCO POWER TECHNOLOGIES. USE PERMITTED FOR OUR WORK ONLY. ALL RIGHTS OF DESIGN OR INVENTION ARE RESERVED.	
DRAWING APPROVAL	WK	DATE	3/21/01		
FINAL APPROVAL					

ASCO ASCO POWER TECHNOLOGIES, L.P.
 FLORHAM PARK, NEW JERSEY 07932 U.S.A.

E	203565	AE	BK	02/26/05
SEE ECN				
D	160786	BK	BK	5/30/02
SEE ECN				
C	158022	DRS	DRS	6/21/01
SEE ECN				
B	157827	DRS	DRS	5/30/01
SEE ECN				
A	157219	BK	BK	4/01
SEE ECN				
—	156950	CT	WK	03/01/01
ISSUE				

CHANGE LETTER	ECN NO.	BY	APP.	DATE

SUBSIDIARY DISTRIBUTION			
AE	<input type="checkbox"/>	AN	<input type="checkbox"/>
AM	<input type="checkbox"/>	AO	<input type="checkbox"/>
AP	<input type="checkbox"/>	AS	<input type="checkbox"/>
AR	<input type="checkbox"/>	AT	<input type="checkbox"/>
AV	<input type="checkbox"/>	AW	<input type="checkbox"/>
AX	<input type="checkbox"/>	AY	<input type="checkbox"/>
BA	<input type="checkbox"/>	BB	<input type="checkbox"/>
BC	<input type="checkbox"/>	BD	<input type="checkbox"/>
BE	<input type="checkbox"/>	BF	<input type="checkbox"/>
BG	<input type="checkbox"/>	BH	<input type="checkbox"/>
BI	<input type="checkbox"/>	BJ	<input type="checkbox"/>
BK	<input type="checkbox"/>	BL	<input type="checkbox"/>
BM	<input type="checkbox"/>	BN	<input type="checkbox"/>
BO	<input type="checkbox"/>	BP	<input type="checkbox"/>
BQ	<input type="checkbox"/>	BR	<input type="checkbox"/>
BS	<input type="checkbox"/>	BT	<input type="checkbox"/>
BU	<input type="checkbox"/>	BV	<input type="checkbox"/>
BW	<input type="checkbox"/>	BX	<input type="checkbox"/>
BY	<input type="checkbox"/>	BZ	<input type="checkbox"/>
CA	<input type="checkbox"/>	CB	<input type="checkbox"/>
CC	<input type="checkbox"/>	CD	<input type="checkbox"/>
CE	<input type="checkbox"/>	CF	<input type="checkbox"/>
CG	<input type="checkbox"/>	CH	<input type="checkbox"/>
CI	<input type="checkbox"/>	CL	<input type="checkbox"/>
CM	<input type="checkbox"/>	CN	<input type="checkbox"/>
CO	<input type="checkbox"/>	CP	<input type="checkbox"/>
CQ	<input type="checkbox"/>	CR	<input type="checkbox"/>
CS	<input type="checkbox"/>	CT	<input type="checkbox"/>
CU	<input type="checkbox"/>	CV	<input type="checkbox"/>
CV	<input type="checkbox"/>	CW	<input type="checkbox"/>
CX	<input type="checkbox"/>	CY	<input type="checkbox"/>
CA	<input type="checkbox"/>	CB	<input type="checkbox"/>
CC	<input type="checkbox"/>	CD	<input type="checkbox"/>
CE	<input type="checkbox"/>	CF	<input type="checkbox"/>
CG	<input type="checkbox"/>	CH	<input type="checkbox"/>
CI	<input type="checkbox"/>	CL	<input type="checkbox"/>
CM	<input type="checkbox"/>	CN	<input type="checkbox"/>
CO	<input type="checkbox"/>	CP	<input type="checkbox"/>
CQ	<input type="checkbox"/>	CR	<input type="checkbox"/>
CS	<input type="checkbox"/>	CT	<input type="checkbox"/>
CU	<input type="checkbox"/>	CV	<input type="checkbox"/>
CV	<input type="checkbox"/>	CW	<input type="checkbox"/>
CX	<input type="checkbox"/>	CY	<input type="checkbox"/>
CA	<input type="checkbox"/>	CB	<input type="checkbox"/>
CC	<input type="checkbox"/>	CD	<input type="checkbox"/>
CE	<input type="checkbox"/>	CF	<input type="checkbox"/>
CG	<input type="checkbox"/>	CH	<input type="checkbox"/>
CI	<input type="checkbox"/>	CL	<input type="checkbox"/>
CM	<input type="checkbox"/>	CN	<input type="checkbox"/>
CO	<input type="checkbox"/>	CP	<input type="checkbox"/>
CQ	<input type="checkbox"/>	CR	<input type="checkbox"/>
CS	<input type="checkbox"/>	CT	<input type="checkbox"/>
CU	<input type="checkbox"/>	CV	<input type="checkbox"/>
CV	<input type="checkbox"/>	CW	<input type="checkbox"/>
CX	<input type="checkbox"/>	CY	<input type="checkbox"/>
CA	<input type="checkbox"/>	CB	<input type="checkbox"/>
CC	<input type="checkbox"/>	CD	<input type="checkbox"/>
CE	<input type="checkbox"/>	CF	<input type="checkbox"/>
CG	<input type="checkbox"/>	CH	<input type="checkbox"/>
CI	<input type="checkbox"/>	CL	<input type="checkbox"/>
CM	<input type="checkbox"/>	CN	<input type="checkbox"/>
CO	<input type="checkbox"/>	CP	<input type="checkbox"/>
CQ	<input type="checkbox"/>	CR	<input type="checkbox"/>
CS	<input type="checkbox"/>	CT	<input type="checkbox"/>
CU	<input type="checkbox"/>	CV	<input type="checkbox"/>
CV	<input type="checkbox"/>	CW	<input type="checkbox"/>
CX	<input type="checkbox"/>	CY	<input type="checkbox"/>
CA	<input type="checkbox"/>	CB	<input type="checkbox"/>
CC	<input type="checkbox"/>	CD	<input type="checkbox"/>
CE	<input type="checkbox"/>	CF	<input type="checkbox"/>
CG	<input type="checkbox"/>	CH	<input type="checkbox"/>
CI	<input type="checkbox"/>	CL	<input type="checkbox"/>
CM	<input type="checkbox"/>	CN	<input type="checkbox"/>
CO	<input type="checkbox"/>	CP	<input type="checkbox"/>
CQ	<input type="checkbox"/>	CR	<input type="checkbox"/>
CS	<input type="checkbox"/>	CT	<input type="checkbox"/>
CU	<input type="checkbox"/>	CV	<input type="checkbox"/>
CV	<input type="checkbox"/>	CW	<input type="checkbox"/>
CX	<input type="checkbox"/>	CY	<input type="checkbox"/>
CA	<input type="checkbox"/>	CB	<input type="checkbox"/>
CC	<input type="checkbox"/>	CD	<input type="checkbox"/>
CE	<input type="checkbox"/>	CF	<input type="checkbox"/>
CG	<input type="checkbox"/>	CH	<input type="checkbox"/>
CI	<input type="checkbox"/>	CL	<input type="checkbox"/>
CM	<input type="checkbox"/>	CN	<input type="checkbox"/>
CO	<input type="checkbox"/>	CP	<input type="checkbox"/>
CQ	<input type="checkbox"/>	CR	<input type="checkbox"/>
CS	<input type="checkbox"/>	CT	<input type="checkbox"/>
CU	<input type="checkbox"/>	CV	<input type="checkbox"/>
CV	<input type="checkbox"/>	CW	<input type="checkbox"/>
CX	<input type="checkbox"/>	CY	<input type="checkbox"/>
CA	<input type="checkbox"/>	CB	<input type="checkbox"/>
CC	<input type="checkbox"/>	CD	<input type="checkbox"/>
CE	<input type="checkbox"/>	CF	<input type="checkbox"/>
CG	<input type="checkbox"/>	CH	<input type="checkbox"/>
CI	<input type="checkbox"/>	CL	<input type="checkbox"/>
CM	<input type="checkbox"/>	CN	<input type="checkbox"/>
CO	<input type="checkbox"/>	CP	<input type="checkbox"/>
CQ	<input type="checkbox"/>	CR	<input type="checkbox"/>
CS	<input type="checkbox"/>	CT	<input type="checkbox"/>
CU	<input type="checkbox"/>	CV	<input type="checkbox"/>
CV	<input type="checkbox"/>	CW	<input type="checkbox"/>
CX	<input type="checkbox"/>	CY	<input type="checkbox"/>
CA	<input type="checkbox"/>	CB	<input type="checkbox"/>
CC	<input type="checkbox"/>	CD	<input type="checkbox"/>
CE	<input type="checkbox"/>	CF	<input type="checkbox"/>
CG	<input type="checkbox"/>	CH	<input type="checkbox"/>
CI	<input type="checkbox"/>	CL	<input type="checkbox"/>
CM	<input type="checkbox"/>	CN	<input type="checkbox"/>
CO	<input type="checkbox"/>	CP	<input type="checkbox"/>
CQ	<input type="checkbox"/>	CR	<input type="checkbox"/>
CS	<input type="checkbox"/>	CT	<input type="checkbox"/>
CU	<input type="checkbox"/>	CV	<input type="checkbox"/>
CV	<input type="checkbox"/>	CW	<input type="checkbox"/>
CX	<input type="checkbox"/>	CY	<input type="checkbox"/>
CA	<input type="checkbox"/>	CB	<input type="checkbox"/>
CC	<input type="checkbox"/>	CD	<input type="checkbox"/>
CE	<input type="checkbox"/>	CF	<input type="checkbox"/>
CG	<input type="checkbox"/>	CH	<input type="checkbox"/>
CI	<input type="checkbox"/>	CL	<input type="checkbox"/>
CM	<input type="checkbox"/>	CN	<input type="checkbox"/>
CO	<input type="checkbox"/>	CP	<input type="checkbox"/>
CQ	<input type="checkbox"/>	CR	<input type="checkbox"/>
CS	<input type="checkbox"/>	CT	<input type="checkbox"/>
CU	<input type="checkbox"/>	CV	<input type="checkbox"/>
CV	<input type="checkbox"/>	CW	<input type="checkbox"/>
CX	<input type="checkbox"/>	CY	<input type="checkbox"/>
CA	<input type="checkbox"/>	CB	<input type="checkbox"/>
CC	<input type="checkbox"/>	CD	<input type="checkbox"/>
CE	<input type="checkbox"/>	CF	<input type="checkbox"/>
CG	<input type="checkbox"/>	CH	<input type="checkbox"/>
CI	<input type="checkbox"/>	CL	<input type="checkbox"/>
CM	<input type="checkbox"/>	CN	<input type="checkbox"/>
CO	<input type="checkbox"/>	CP	<input type="checkbox"/>
CQ	<input type="checkbox"/>	CR	<input type="checkbox"/>
CS	<input type="checkbox"/>	CT	<input type="checkbox"/>
CU	<input type="checkbox"/>	CV	<input type="checkbox"/>
CV	<input type="checkbox"/>	CW	<input type="checkbox"/>
CX	<input type="checkbox"/>	CY	<input type="checkbox"/>
CA	<input type="checkbox"/>	CB	<input type="checkbox"/>
CC	<input type="checkbox"/>	CD	<input type="checkbox"/>
CE	<input type="checkbox"/>	CF	<input type="checkbox"/>
CG	<input type="checkbox"/>	CH	<input type="checkbox"/>
CI	<input type="checkbox"/>	CL	<input type="checkbox"/>
CM	<input type="checkbox"/>	CN	<input type="checkbox"/>
CO	<input type="checkbox"/>	CP	<input type="checkbox"/>
CQ	<input type="checkbox"/>	CR	<input type="checkbox"/>
CS	<input type="checkbox"/>	CT	<input type="checkbox"/>
CU	<input type="checkbox"/>	CV	<input type="checkbox"/>
CV	<input type="checkbox"/>	CW	<input type="checkbox"/>
CX	<input type="checkbox"/>	CY	<input type="checkbox"/>
CA	<input type="checkbox"/>	CB	<input type="checkbox"/>
CC	<input type="checkbox"/>	CD	<input type="checkbox"/>
CE	<input type="checkbox"/>	CF	<input type="checkbox"/>
CG	<input type="checkbox"/>	CH	<input type="checkbox"/>
CI	<input type="checkbox"/>	CL	<input type="checkbox"/>
CM	<input type="checkbox"/>	CN	<input type="checkbox"/>
CO	<input type="checkbox"/>	CP	<input type="checkbox"/>
CQ	<input type="checkbox"/>	CR	<input type="checkbox"/>
CS	<input type="checkbox"/>	CT	<input type="checkbox"/>
CU	<input type="checkbox"/>	CV	<input type="checkbox"/>
CV	<input type="checkbox"/>	CW	<input type="checkbox"/>
CX	<input type="checkbox"/>	CY	<input type="checkbox"/>
CA	<input type="checkbox"/>	CB	<input type="checkbox"/>
CC	<input type="checkbox"/>	CD	<input type="checkbox"/>
CE	<input type="checkbox"/>	CF	<input type="checkbox"/>
CG	<input type="checkbox"/>	CH	<input type="checkbox"/>
CI	<input type="checkbox"/>	CL	<input type="checkbox"/>
CM	<input type="checkbox"/>	CN	<input type="checkbox"/>
CO	<input type="checkbox"/>	CP	<input type="checkbox"/>
CQ	<input type="checkbox"/>	CR	<input type="checkbox"/>
CS	<input type="checkbox"/>	CT	<input type="checkbox"/>
CU	<input type="checkbox"/>	CV	<input type="checkbox"/>
CV	<input type="checkbox"/>	CW	<input type="checkbox"/>
CX	<input type="checkbox"/>	CY	<input type="checkbox"/>
CA	<input type="checkbox"/>	CB	<input type="checkbox"/>
CC	<input type="checkbox"/>	CD	<input type="checkbox"/>
CE	<input type="checkbox"/>	CF	<input type="checkbox"/>
CG	<input type="checkbox"/>	CH	<input type="checkbox"/>
CI	<input type="checkbox"/>	CL	<input type="checkbox"/>
CM	<input type="checkbox"/>	CN	<input type="checkbox"/>
CO	<input type="checkbox"/>	CP	<input type="checkbox"/>
CQ	<input type="checkbox"/>	CR	<input type="checkbox"/>
CS	<input type="checkbox"/>	CT	<input type="checkbox"/>
CU	<input type="checkbox"/>	CV	<input type="checkbox"/>
CV	<input type="checkbox"/>	CW	<input type="checkbox"/>
CX	<input type="checkbox"/>	CY	<input type="checkbox"/>
CA	<input type="checkbox"/>	CB	<input type="checkbox"/>
CC	<input type="checkbox"/>	CD	<input type="checkbox"/>
CE	<input type="checkbox"/>	CF	<input type="checkbox"/>
CG	<input type="checkbox"/>	CH	<input type="checkbox"/>
CI	<input type="checkbox"/>	CL	<input type="checkbox"/>
CM	<input type="checkbox"/>	CN	<input type="checkbox"/>
CO	<input type="checkbox"/>	CP	<input type="checkbox"/>
CQ	<input type="checkbox"/>	CR	<input type="checkbox"/>
CS	<input type="checkbox"/>	CT	<input type="checkbox"/>
CU	<input type="checkbox"/>	CV	<input type="checkbox"/>
CV	<input type="checkbox"/>	CW	<input type="checkbox"/>
CX	<input type="checkbox"/>	CY	<input type="checkbox"/>
CA			

FIELD CONNECTIONS

MAIN POWER POLES

CIRCUIT

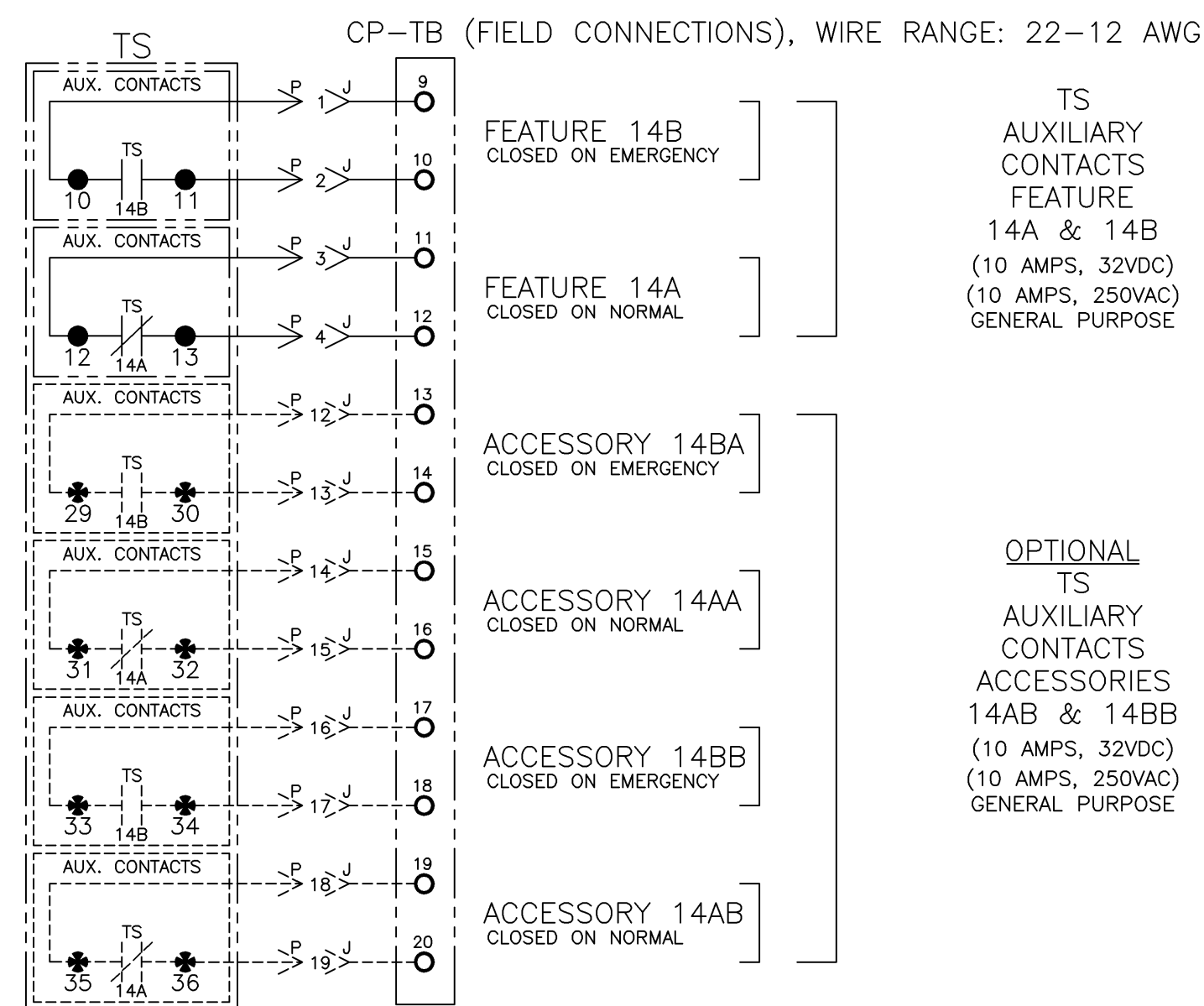

TS
AUXILIARY
CONTACTS
FEATURE
14A & 14B
(10 AMPS, 32VDC)
(10 AMPS, 250VAC)
GENERAL PURPOSE

OPTIONAL
TS
AUXILIARY
CONTACTS
ACCESSORIES
14AB & 14BB
(10 AMPS, 32VDC)
(10 AMPS, 250VAC)
GENERAL PURPOSE

EMERGENCY

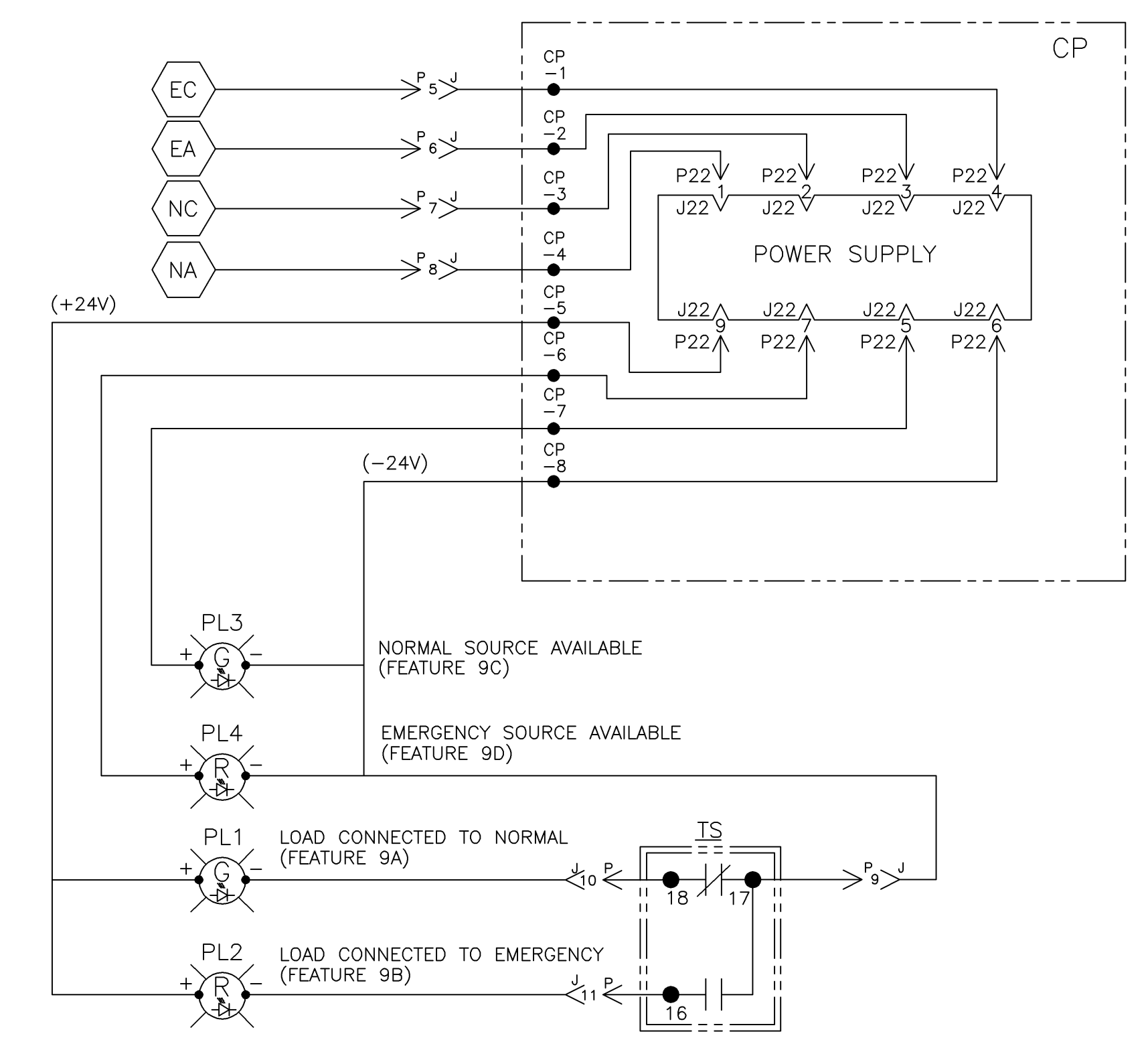
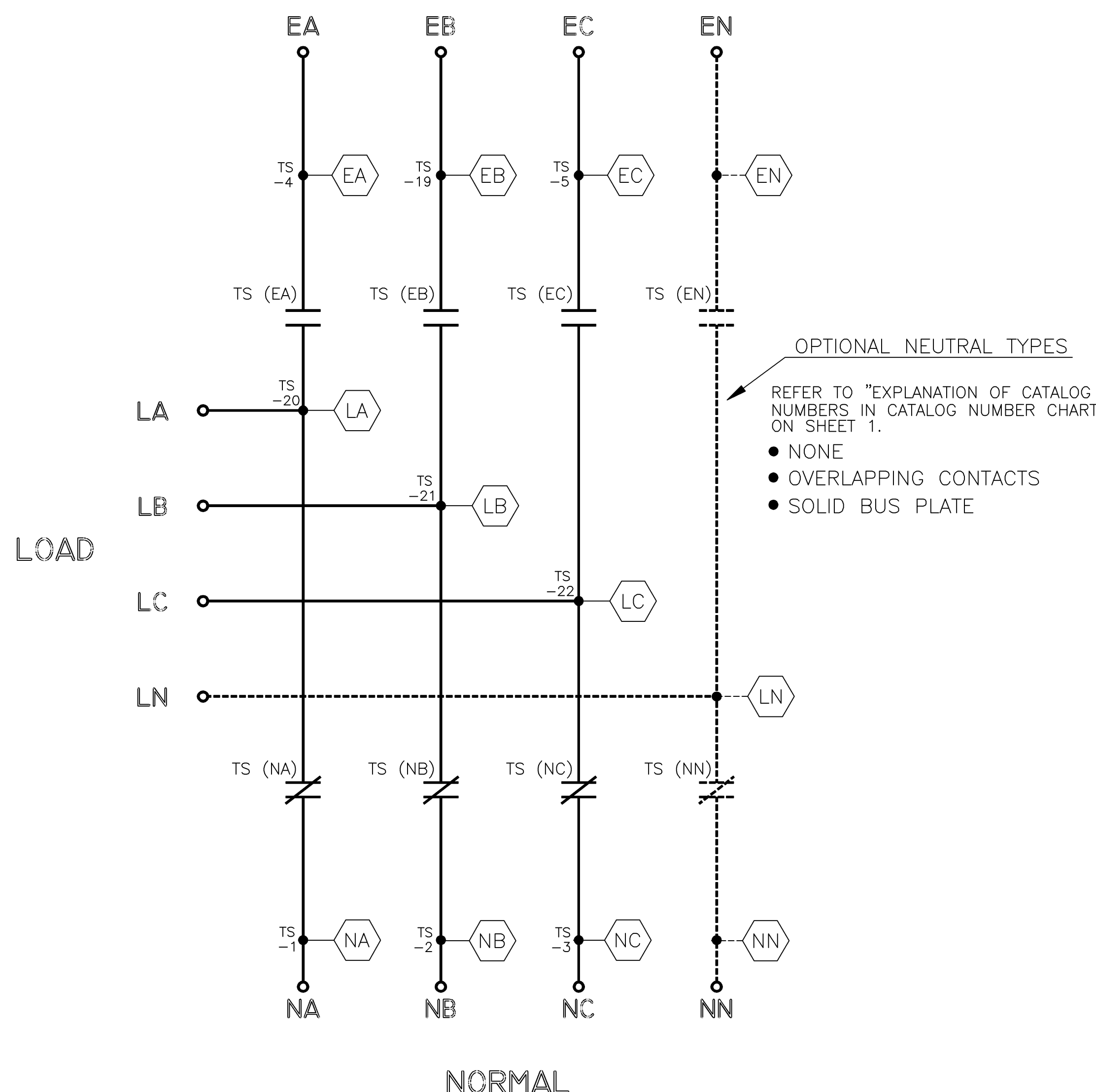

PROJECT NAME:		E 203565 AE BK 02/26/05	
WIRING DIAGRAM		SEE ECN	
7000 SERIES (7MTS)		SUBSIDIARY DISTRIBUTION	
MANUALLY OPERATED TS		THIRD ANGLE PROJECTION	
BY	DATE	MANUFACTURING TOLERANCES TO BE IN ACCORDANCE WITH ASCO PROCEDURE MP-1-003. FOR PLASTIC PARTS SEE MP-1-005	ASSEM. REF. NO.
CT	03/01/01		
CHECKED	BK	3/20/01	PROPERTY OF ASCO POWER TECHNOLOGIES. USE PERMITTED FOR OUR WORK ONLY. ALL RIGHTS OF DESIGN OR INVENTION ARE RESERVED.
DRAFTING	WK	3/21/01	
APPROVAL			
SCALE 1:1		ACAD FILE	
SIZE DWG. NO. DS717619		COMPUTER GENERATED DRAWING	
ASCO		ASCO POWER TECHNOLOGIES, L.P. FLORHAM PARK, NEW JERSEY 07932 U.S.A.	
CHANGE LETTER	ECN NO.	BY	DATE
E	203565		
SHEET 2 OF 3			

