

THREE PHASE WIRING FOR ASCO 7000 SERIES NON-AUTOMATIC TRANSFER SWITCHES TYPE 7NTS RATED 30, 70, 100, 150, 200, & 230 AMPERES

FEATURES, SETTINGS, OPERATION, ACCESSORIES & NOTES

THE FOLLOWING FEATURES AND RELATED SETTINGS ARE PART OF THE GROUP 5 CONTROL PANEL'S USER CONFIGURABLE PARAMETERS. FOR DETAILED INFORMATION REGARDING THE CONFIGURATION OF THESE PARAMETERS AND OTHER FEATURES OF THE GROUP 5 CONTROL PANEL, REFER TO THE GROUP 5 CONTROL PANEL FOR ASCO 7000 SERIES TRANSFER SWITCHES USER'S GUIDE (PART NO. 381333-126) PROVIDED WITH EVERY 7000 SERIES TRANSFER SWITCH.

THE NOMINAL OPERATING VOLTAGE & FREQUENCY IS PRE-PROGRAMMED AT THE FACTORY BASED ON THE NAMEPLATE DATA PRINTED ON THE TRANSFER SWITCH & CONTROL PANEL NAMEPLATES.

VOLTAGE & FREQUENCY SENSING

THE FOLLOWING SETTINGS ARE EXPRESSED AS A PERCENTAGE OF THE CONTROL PANEL'S NOMINAL VOLTAGE SETTING UNLESS STATED OTHERWISE. ALL SETTINGS ARE ADJUSTABLE IN INCREMENTS OF 1%.

A. RMS VOLTAGE SENSING ON ALL PHASES OF THE NORMAL & EMERGENCY SOURCES.

PARAMETER	RANGE OF SETTINGS	DEFAULT SETTING
NORMAL VOLTAGE DROPOUT	70-98%	85%
NORMAL VOLTAGE PICKUP	85-100%	90%
NORMAL OVER VOLTAGE TRIP	102-115%	OFF
NORMAL VOLTAGE UNBALANCE	YES/NO	NO
NORMAL VOLTAGE UNBALANCE DROPOUT	5-20% OF AVG. NORMAL VOLTAGE	20% (if ON)
NORMAL VOLTAGE UNBALANCE PICKUP	3-18% OF AVG. NORMAL VOLTAGE	10% (if ON)
EMERGENCY VOLTAGE DROPOUT	70-98%	75%
EMERGENCY VOLTAGE PICKUP	85-100%	90%
EMERGENCY OVER VOLTAGE TRIP	102-115%	OFF
EMERGENCY VOLTAGE UNBALANCE	YES/NO	NO
EMERGENCY VOLTAGE UNBALANCE DROPOUT	5-20% OF AVG. EMERGENCY VOLTAGE	20% (if ON)
EMERGENCY VOLTAGE UNBALANCE PICKUP	3-18% OF AVG. EMERGENCY VOLTAGE	10% (if ON)

B. FREQUENCY SENSING OF THE NORMAL & EMERGENCY SOURCES.

PARAMETER	RANGE OF SETTINGS	DEFAULT SETTING
NORMAL FREQUENCY DROPOUT	85-98%	90%
NORMAL FREQUENCY PICKUP	90-100%	95%
NORMAL OVER FREQUENCY TRIP	102-110%	OFF
EMERGENCY FREQUENCY DROPOUT	85-98%	90%
EMERGENCY FREQUENCY PICKUP	90-100%	95%
EMERGENCY OVER FREQUENCY TRIP	102-110%	OFF

TIME DELAYS

THE FOLLOWING TIME DELAY SETTINGS ALL HAVE AN ADJUSTABLE RANGE OF 0-60 min 59 sec UNLESS STATED OTHERWISE. ADJUSTABLE IN INCREMENTS OF 1 sec.

NOTE: SOME TIME DELAYS MAY BE EFFECTED BY CUSTOMER REQUESTED ACCESSORIES PROVIDED WITH THE UNIT. REFER TO THE DESCRIPTIONS PROVIDED UNDER THE "ACCESSORIES" NOTES ON THIS PAGE.

FEATURE	NAME	DEFAULT SETTING
1C	NORMAL SOURCE FAILURE TO ENGINE START	1 sec
2B	TRANSFER TO EMERGENCY ON AVAILABILITY OF EMERGENCY SOURCE	0 sec
1F	EMERGENCY SOURCE FAILURE RETRANSFER (NORMAL SOURCE AVAILABLE)	0 sec
2E	ENGINE COOLDOWN FOLLOWING RETRANSFER TO NORMAL	5 min
3A	RETRANSFER TO NORMAL (NORMAL FAILURE MODE)	30 min
-	DELAYED TRANSFER (LOAD "OFF" TIME), [0-5 min 59 sec]	3 sec

DESCRIPTIONS OF TIME DELAYS:

- FEAT. 1C - DELAY ON NORMAL SOURCE OUTAGE. STARTS ON FAILURE OF NORMAL SOURCE. RESETS IF NORMAL SOURCE IS ACCEPTED BEFORE EXPIRATION. INHIBITS ENGINE STARTING AND TRANSFER UNTIL EXPIRATION.
- FEAT. 2B - DELAY PRIOR TO TRANSFER TO THE EMERGENCY SOURCE. DELAY STARTS ON EXPIRATION OF FEAT. 1C AND WHEN THE EMERGENCY SOURCE HAS BEEN ACCEPTED. DELAY RESETS IF THE EMERGENCY SOURCE FAILS PRIOR TO EXPIRATION. ON EXPIRATION, TRANSFER TO EMERGENCY IS INITIATED UNLESS THE NORMAL SOURCE HAS RECOVERED AND THE "COMMIT TO TRANSFER" FEATURE IS SET TO "NO" COMMIT. PROVIDES A PERIOD FOR EMERGENCY SOURCE STABILIZATION OR STAGING OF MULTIPLE TRANSFER SWITCH CONTROLLED LOADS TO THE EMERGENCY SOURCE.
- FEAT. 1F - DELAY ON RETRANSFER TO NORMAL IN THE EVENT OF EMERGENCY SOURCE FAILURE. DELAY BEGINS ON FAILURE OF THE EMERGENCY SOURCE IF THE NORMAL SOURCE IS ACCEPTABLE. ON EXPIRATION, RETRANSFER TO NORMAL WILL BE INITIATED.
- FEAT. 2E - DELAY ON ENGINE SHUTDOWN (ENGINE COOL DOWN PERIOD). DELAY STARTS FOLLOWING RETRANSFER TO THE NORMAL SOURCE. PROVIDES A PERIOD FOR THE ENGINE-GENERATOR SET TO RUN UNLOADED PRIOR TO SHUTDOWN.
- FEAT. 3A - RETRANSFER TO NORMAL DELAY (NORMAL FAILURE MODE) DELAY STARTS WHEN NORMAL SOURCE IS ACCEPTED (FOLLOWING IT'S FAILURE) AND WHILE THE LOAD IS CONNECTED TO EMERGENCY. RESETS IF NORMAL FAILS PRIOR TO EXPIRATION OR IF THE EMERGENCY SOURCE FAILS BEFORE EXPIRATION AND FEAT. 1F EXPIRES (AUTOMATIC BYPASS ON EMERGENCY SOURCE FAILURE). PROVIDES A PERIOD FOR THE NORMAL SOURCE TO STABILIZE PRIOR TO RETRANSFER.

MOTOR LOAD TRANSFER FEATURE

FEAT. 27 - INPHASE TRANSFER CONTROL LOGIC TO INITIATE AN INPHASE TRANSFER OF LOADS BETWEEN LIVE SOURCES. USED TO PREVENT NUISANCE TRIPPING OF CIRCUIT BREAKERS AND POSSIBLE DAMAGE TO MECHANICAL LOADS CAUSED BY OUT OF PHASE TRANSFER. ACTIVATED VIA THE GROUP 5 CONTROL PANEL USER INTERFACE (TRANSFER CONTROL CENTER) BY SELECTING "IN-PHASE MONITOR ENABLE" = YES. AN ADJUSTABLE DELAY (0.0-3.0 sec, FACTORY SET TO 1.5 sec, IN INCREMENTS OF 0.1 sec) DELAYS SENSING TO PERMIT STABILIZATION OF THE SOURCES PRIOR TO SENSING. FACTORY SETTING IS DISABLED UNLESS SPECIFIED TO BE FACTORY ACTIVATED AT THE TIME OF ORDER.

* 200 & 230 AMP SIZES ARE 480V MAX.

ENGINE EXERCISER

THE ENGINE EXERCISER FEATURE PROVIDES A MEANS TO PERFORM AN EXERCISING OF THE ENGINE-GENERATOR SET EITHER WITH OR WITHOUT LOAD TRANSFER.

THE USER CAN PROGRAM UP TO SEVEN DIFFERENT EXERCISE ROUTINES. EACH ROUTINE INCLUDES:

1. ENABLE OR DISABLE THE ROUTINE
2. ENABLE OR DISABLE TRANSFER OF THE LOAD DURING THE ROUTINE
3. SET START TIME OF ROUTINE -
 - TIME OF DAY
 - DAY OF WEEK
 - WEEK OF MONTH (1st, 2nd, 3rd, 4th, ALTERNATE OR ALL)
4. SET THE DURATION OF THE ROUTINE

PARAMETER	RANGE OF SETTING	DEFAULT SETTING
MONTH (CLOCK SET)	JAN FEB MAR APR MAY JUN JUL AUG SEP	CURRENT DATE
DAY	OCT NOV DEC	1-31
YEAR	1-99	00-99
HOUR	0-23	0-23
MINUTE	0-59	0-59
ENABLE ROUTINE (ROUTINE 1-7)	YES/NO	NO
TRANSFER LOAD	YES/NO	NO
START HOUR	0-23	0
START MINUTE	0-59	0
RUN WEEK	ALL, ALTERNATE, 1st, 2nd, 3rd, 4th, 5th	ALL
RUN DAY	SUN MON TUE WED THU FRI SAT	SUN
DURATION HOURS	0-23	0
DURATION MINUTES	0-59	0

SIGNALS & AUXILIARIES

A. FEATURES 7 & 8- ENGINE START SIGNAL. SIGNAL INITIATED BY DROPOUT OF CONTROL PANEL RELAY (NR) FOLLOWING EXPIRATION OF THE FEATURE 1C TIME DELAY (DELAY TO OVERRIDE MOMENTARY NORMAL SOURCE OUTAGES). FEATURE 7 CLOSSES TO SIGNAL ENGINE START. FEATURE 8 OPENS TO SIGNAL ENGINE START. ENGINE STARTING SIGNAL RESETS FOLLOWING RETRANSFER TO THE NORMAL SOURCE AND EXPIRATION OF THE FEATURE 2E (ENGINE COOL DOWN) TIME DELAY. FEATURES 7 & 8 ARE PROVIDED AS A SINGLE FORM C CONTACT CONNECTED TO THE FIELD CONNECTIONS TERMINAL BLOCK (TB/TS). CONTACT RATED 10 AMPS AT 32 VDC/120VAC RESISTIVE.

B. FEATURES 14AA & 14BA - TRANSFER SWITCH AUXILIARY POSITION INDICATING CONTACTS. TWO (2) FORM A CONTACTS TO INDICATE CONNECTION OF THE TRANSFER SWITCH TO NORMAL (14A) AND TWO (2) FOR EMERGENCY (14B). CONTACTS RATED 10 AMPS, 32 VDC, 480 VAC.

OPERATION

ALL TRANSFERS TO AND FROM EMERGENCY ARE PERFORMED MANUALLY WITH THE USE OF A MANUALLY OPERATED SELECTOR SWITCH.

TRANSFER TO EMERGENCY:

IF THE NORMAL SOURCE FAILS, THE TRANSFER SWITCH INITIATES STARTING OF THE ENGINE-GENERATOR SET. WHEN PROPER VOLTAGE AND FREQUENCY HAVE BEEN ATTAINED, AND AFTER THE MANUALLY OPERATED SELECTOR SWITCH HAS BEEN SET TO EMERGENCY, THE LOAD WILL BE TRANSFERRED TO THE EMERGENCY SOURCE.

RETRANSFER TO NORMAL:

1. IF THE MANUAL SELECTOR SWITCH IS SET TO NORMAL PRIOR TO THE NORMAL SOURCE BEING RESTORED, TRANSFER TO NORMAL WILL OCCUR ONLY AFTER THE NORMAL SOURCE IS RESTORED FOR THE DURATION OF THE FEATURE 3A (RETRANSFER TO NORMAL) TIME DELAY SETTING.
2. IF THE NORMAL SOURCE IS RESTORED AND THE MANUAL SELECTOR SWITCH IS THEN SET TO NORMAL, THE LOAD WILL BE TRANSFERRED TO THE NORMAL SOURCE IMMEDIATELY.

THE ENGINE WILL CONTINUE TO RUN FOR THE ENGINE COOLDOWN PERIOD, FEATURE 2E.

USER CONTROLS AND INDICATIONS

- A. MANUALLY OPERATED SELECTOR SWITCH TO AFFECT TRANSFER TO THE NORMAL OR EMERGENCY SOURCE.
- B. FEATURES 9A & 9B - TRANSFER SWITCH POSITION INDICATORS.
 - FEATURE 9A: TRANSFER SWITCH CLOSED ON NORMAL (GREEN LED)
 - FEATURE 9B: TRANSFER SWITCH CLOSED ON EMERGENCY (RED LED)
- C. FEATURES 9C & 9D - SOURCE ACCEPTANCE INDICATORS.
 - FEATURE 9C: NORMAL SOURCE ACCEPTED (GREEN LED)
 - FEATURE 9D: EMERGENCY SOURCE ACCEPTED (RED LED)

GENERAL NOTES

1. SWITCH SHOWN DE-ENERGIZED AND CONNECTED TO THE NORMAL SOURCE.
2. DEVICE SYMBOLS AND DESIGNATIONS ARE IN ACCORDANCE WITH NEMA PUBLICATION ICS 1-1983, PART 1-101A.
3. ALL WIRING IS #16 AWG, TINNED, STRANDED COPPER UNLESS OTHERWISE INDICATED.
4. ○ ON TERMINAL BLOCKS INDICATES AVAILABLE FIELD CONNECTION POINT.
5. ● ON TERMINAL BLOCKS INDICATES FACTORY CONNECTION POINT.
6. CONTROL AND ACCESSORY WIRING IS ROUTED IN ACCORDANCE WITH ASCO ASSEMBLY PROCEDURE GS451261.
7. AN OPERATOR'S MANUAL IS FURNISHED WITH EACH TRANSFER SWITCH. REFER TO THIS PUBLICATION PRIOR TO INSTALLATION AND OPERATION OF THE UNIT.
8. THE FOLLOWING GROUP 5 CP PARAMETERS ARE TO BE FACTORY SET AS FOLLOWS:

PARAMETER	FACTORY SETTING
FEATURE 34A ENABLE	NO
FEATURE 34B ENABLE	NO

FACTORY CP SETTINGS

PARAMETER	SETTING	
	DEFAULT	FACTORY
<TEST OR MANUAL MODE INPUT>	"YES"	"NO"
TEST OPERATION	"NO"	"YES"
MANUAL OPERATION	"NO"	"YES"
TD E>N (TEST MODE)	"30 sec"	"0 sec"

BASE CATALOG NUMBER				CATALOG NUMBER SUFFIXES				EXPLANATION OF CATALOG NUMBER CODES						
TS FRAME	CATALOG TYPE	NEUTRAL TYPE	PHASE POLES	AMPS	VOLT CODE	CONTROLLER	OPTIONAL ACCESSORY	ENCLOSURE CODE	NEUTRAL TYPE CODE	VOLTAGE CODES 3 PHASE (3 OR 4 WIRE) 50 OR 60 HZ	ENCLOSURE CODES	CODE	TYPE	DESCRIPTION
D	7NTS	A	3	30	A	5	X	C	BLANK	NONE	A	115	BLANK	OPEN TYPE (NO ENCLOSURE)
		B		70	B			E	A	SOLID	B	120	C	GENERAL PURPOSE, INDOOR
		C		100	C			F	B	SWITCHING	C	208	E	INDOOR, WATER & DUST RESISTANT
				150	D			G	C	OVERLAPPING	D	220	F	3R OUTDOOR, RAINPROOF, SLEET & ICE RESISTANT
				200*	E			H	D		E	230	G	4 INDOOR/OUTDOOR, WATERTIGHT & DUSTTIGHT
				230*	F			I	E		F	240	H	4X TYPE 4 PLUS CORROSION RESISTANCE (STAINLESS STEEL)
					G			J	F		G	277	J	4X TYPE 4 PLUS CORROSION RESISTANCE (FIBERGLASS)
					H			K	G		H	380	K	7 EXPLOSION PROOF
					I			L	H		I	400	L	12 INDOOR, INDUSTRIAL ENVIRONMENTS, OILTIGHT & DUSTTIGHT
					J			M	J		J	415	M	3R (SECURE ENCLOSURES)
					K			N	K		K	440	N	4 INDOOR/OUTDOOR, RAINPROOF, SLEET & ICE RESISTANT
					L			P	L		L	460	P	4X INDOOR/OUTDOOR, WATERTIGHT & DUSTTIGHT
					M			Q	M		M	480	Q	12 TYPE 4 PLUS CORROSION RESISTANCE (STAINLESS STEEL)
					N				N		N	550*	P	4X INDOOR, INDUSTRIAL ENVIRONMENTS, OILTIGHT & DUSTTIGHT
					P				P		P	575*	Q	
					Q				Q		Q	600*		

CATALOG NUMBER _____ CERTIFIED TO _____

ASCO S.O. _____

DATE _____

FORM REV C _____

PROJECT NAME: _____

WIRING DIAGRAM

7000 SERIES (7NTS) GROUP 5 CONTROLS

THIRD ANGLE PROJECTION

MANUFACTURING TOLERANCES TO BE IN ACCORDANCE WITH ASCO PROCEDURE MP-1-003. FOR PLASTIC PARTS SEE MP-1-055.

ASSEM. REF. NO. _____

PROPERTY OF ASCO POWER TECHNOLOGIES. USE PERMITTED FOR OUR WORK ONLY. ALL RIGHTS OF DESIGN OR INVENTION ARE RESERVED.

ASCO ASCO POWER TECHNOLOGIES, L.P. FLORHAM PARK, NEW JERSEY 07932 U.S.A.

SCALE 1:1 ACAD FILE

SIZE DWG. NO. DS18511

CHANGE C EON NO. 204563 SHEET 1 OF 6

MAIN POWER POLES

TS OPERATOR CIRCUIT

EMERGENCY

NORMAL

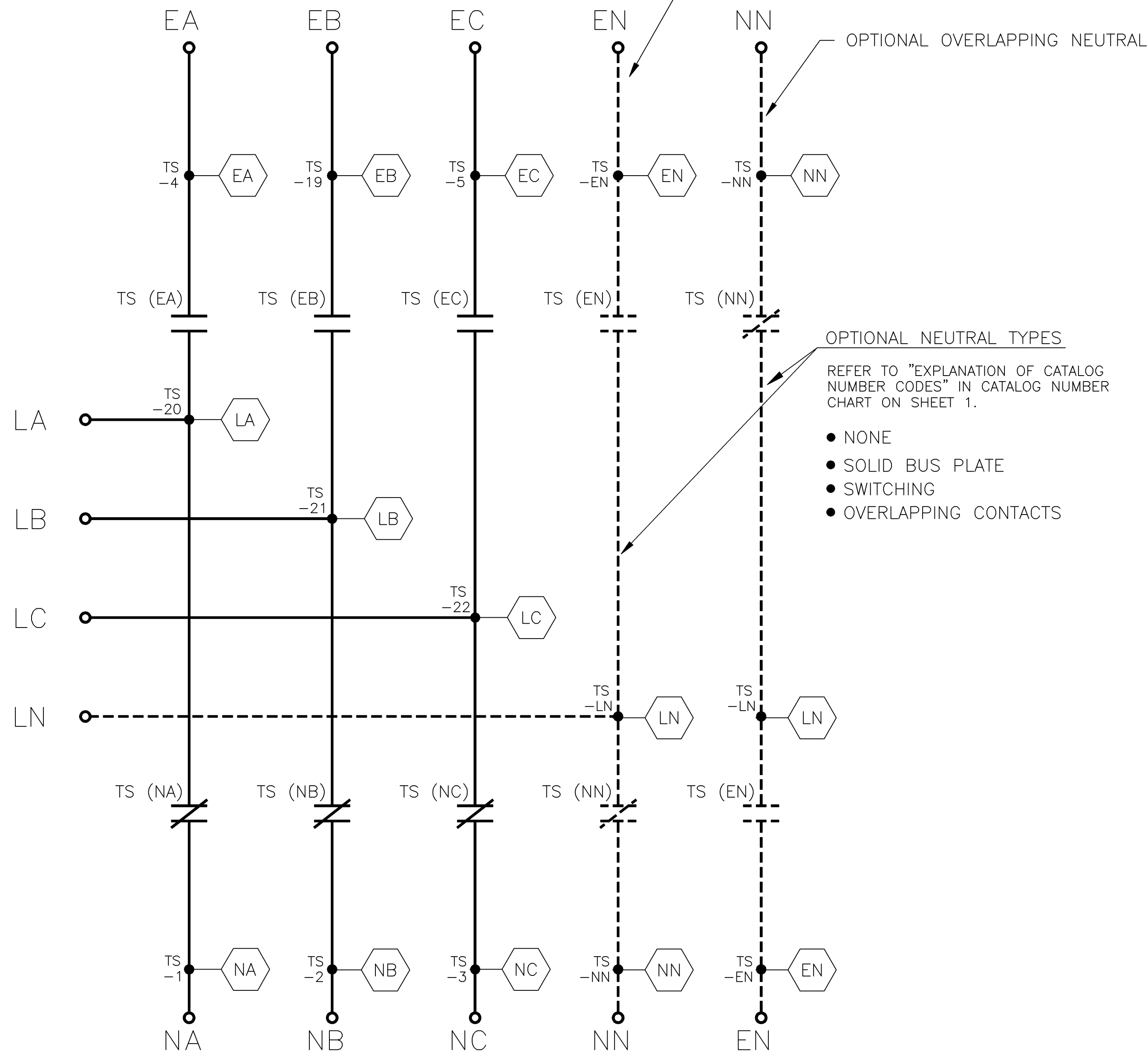

- OPTIONAL NEUTRAL TYPES
REFER TO "EXPLANATION OF CATALOG NUMBER CODES" IN CATALOG NUMBER CHART ON SHEET 1.
- NONE
 - SOLID BUS PLATE
 - SWITCHING
 - OVERLAPPING CONTACTS

NOTE:
TS SHOWN CLOSED ON NORMAL SOURCE.

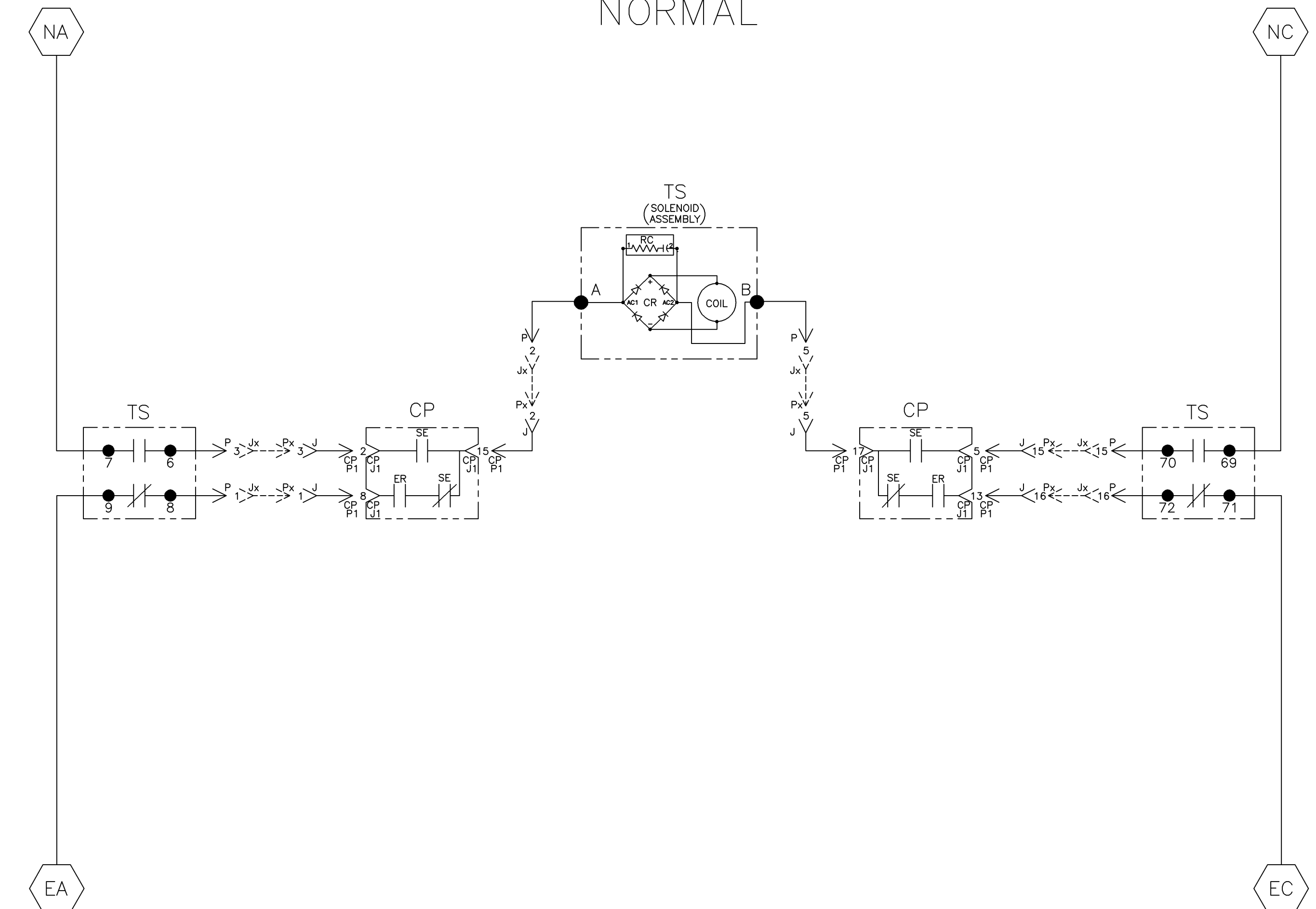

EMERGENCY

TS	SOLENOID POSITION			
	NORM	BEFORE TDC >	BEFORE TDC <	EMER
7-6				
69-70				
8-9				
71-72				

PROJECT NAME:		WIRING DIAGRAM		THIRD ANGLE PROJECTION	
7000 SERIES (7NTS) GROUP 5 CONTROLS		ASCO POWER TECHNOLOGIES, L.P.		FLORHAM PARK, NEW JERSEY 07932 U.S.A.	
DRAWN BY	DJB	DATE	6/02	ASSEMBLY NO.	
CHECKED	BK	DATE	6/02	PROPERTY OF ASCO POWER TECHNOLOGIES. USE PERMITTED FOR OUR WORK ONLY. ALL RIGHTS OF DESIGN OR INVENTION ARE RESERVED.	
DRAFTING APPROVAL	WK	DATE	6/02	SCALE	1:1
FINAL APPROVAL				SIZE	DWG. NO. DS718511
				CHANGE LETTER	C
				ECN NO.	204563
				BY	
				APP.	
				DATE	05/25/05

C	204563	BK	BK	05/25/05
SEE ECN				
B	166966	SDH	SDH	05/04/04
SEE ECN				
A	164537	BWM	WK	08/08/03
SEE ECN				
-	161841	BK	WJ	09/27/02
ISSUE				



NORMAL SOURCE CIRCUITS

ADDITIONAL CIRCUITS

NORMAL

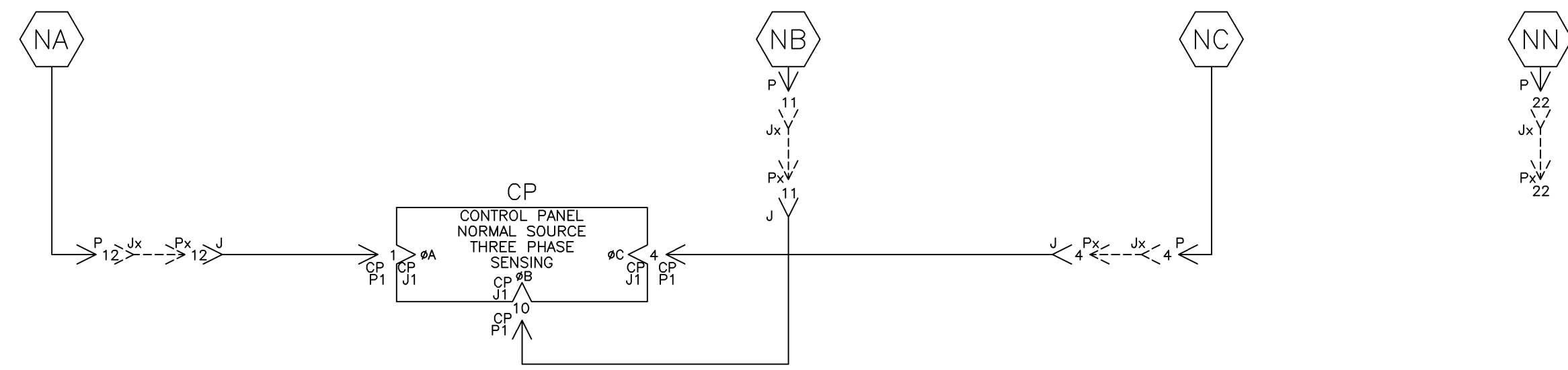

EMERGENCY SOURCE CIRCUITS

EMERGENCY

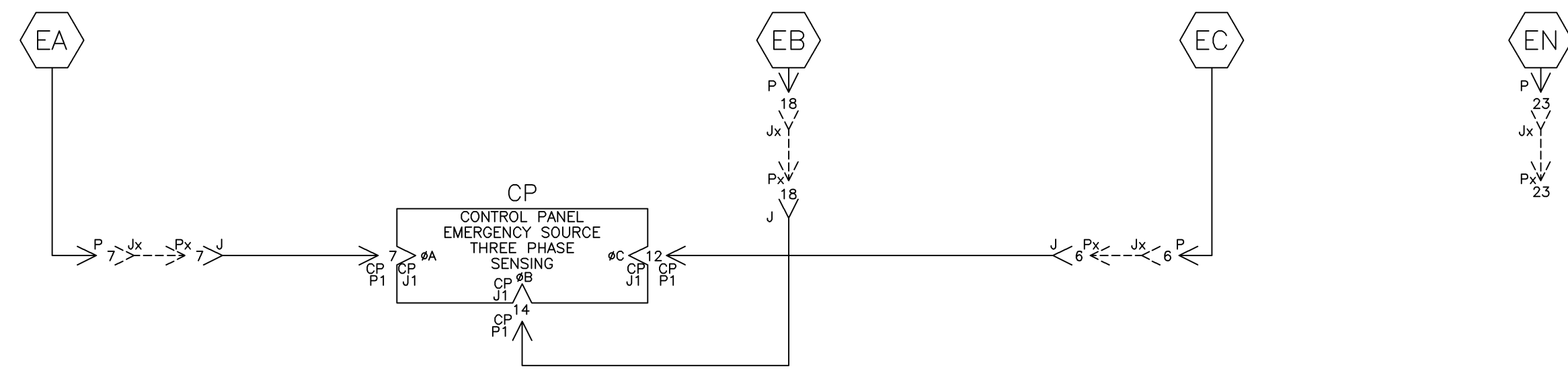

LOAD TERMINAL CIRCUITS

LOAD



CONTROL SIGNALS & INDICATION

USER CONTROLS

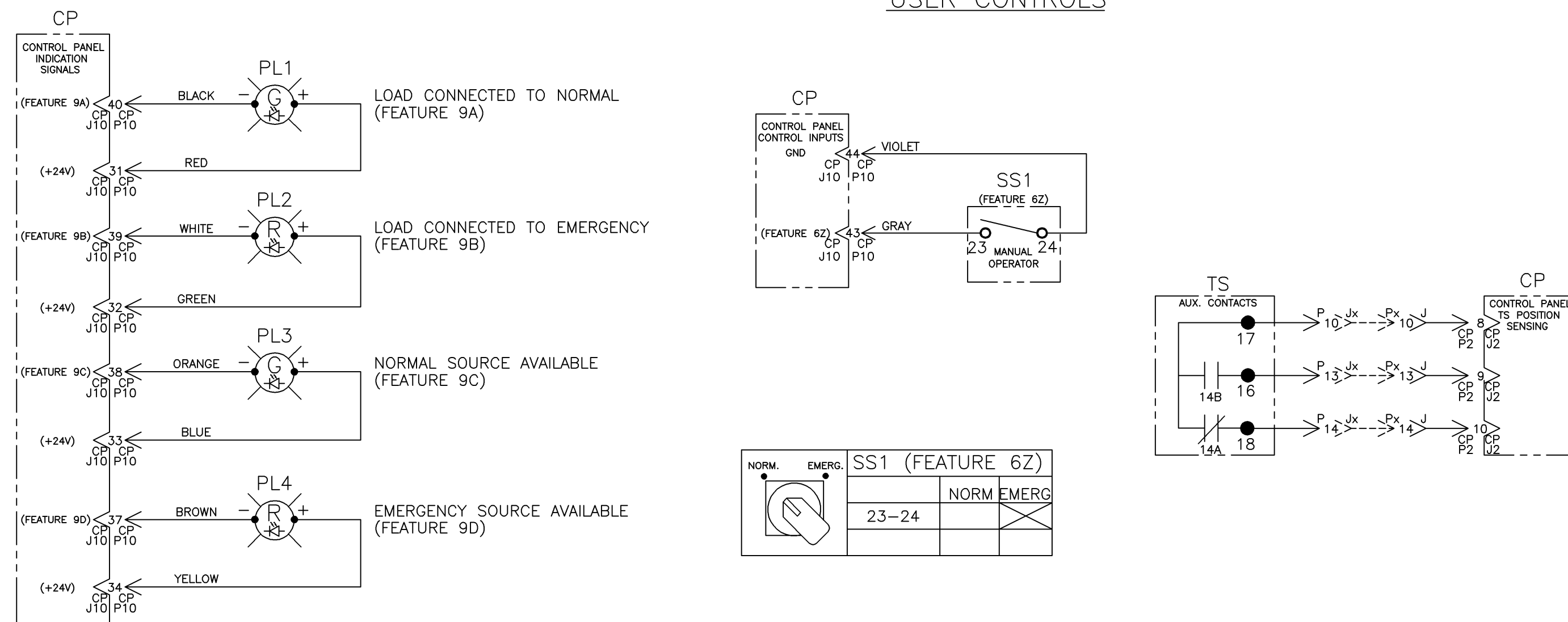

C	204563	BK	BK	05/25/05
B	166966	SDH	SDH	05/04/04
A	164537	BWM	WK	08/08/03
-	161841	BK	WJ	09/27/02
-	ISSUE			

PROJECT NAME: **WIRING DIAGRAM**

7000 SERIES (7NTS) GROUP 5 CONTROLS

THIRD ANGLE PROJECTION

DRAWN BY	DJB	DATE	6/02	MANUFACTURING TOLERANCES TO BE IN ACCORDANCE WITH ASCO PROCEDURE MP-1-003. FOR PLASTIC PARTS SEE MP-1-055	ASSEM. REF. NO.
CHECKED	BK	DATE	6/02	PROPERTY OF ASCO POWER TECHNOLOGIES. USE PERMITTED FOR OUR WORK ONLY. ALL RIGHTS OF DESIGN OR INVENTION ARE RESERVED.	
DRAFTING APPROVAL	WK	DATE	6/02		
FINAL APPROVAL					

SCALE: 1:1 ACAD FILE

SIZE: 11x17 DWG. NO. **DS718511**

CHANGE LETTER: C ECN NO. 204563 SHEET NO. 4 OF 6

ASCO ASCO POWER TECHNOLOGIES, L.P. FLORHAM PARK, NEW JERSEY 07932 U.S.A.

