

# THREE PHASE WIRING FOR ASCO 7000 SERIES AUTOMATIC TRANSFER SWITCHES TYPE J7ATS RATED 260, 400, & 600 AMPERES

## FEATURES, SETTINGS, OPERATION, ACCESSORIES & NOTES

THE FOLLOWING FEATURES AND RELATED SETTINGS ARE PART OF THE GROUP 5 CONTROL PANEL'S USER CONFIGURABLE PARAMETERS. FOR DETAILED INFORMATION REGARDING THE CONFIGURATION OF THESE PARAMETERS AND OTHER FEATURES OF THE GROUP 5 CONTROL PANEL, REFER TO THE GROUP 5 CONTROL PANEL FOR ASCO 7000 SERIES AUTOMATIC TRANSFER SWITCHES USER'S GUIDE (PART NO. 381333-126) PROVIDED WITH EVERY 7000 SERIES AUTOMATIC TRANSFER SWITCH.

THE NOMINAL OPERATING VOLTAGE & FREQUENCY IS PRE-PROGRAMMED AT THE FACTORY BASED ON THE NAMEPLATE DATA PRINTED ON THE TRANSFER SWITCH & CONTROL PANEL NAMEPLATES.

### VOLTAGE & FREQUENCY SENSING

THE FOLLOWING SETTINGS ARE EXPRESSED AS A PERCENTAGE OF THE CONTROL PANEL'S NOMINAL VOLTAGE SETTING UNLESS STATED OTHERWISE. ALL SETTINGS ARE ADJUSTABLE IN INCREMENTS OF 1%.

A. RMS VOLTAGE SENSING ON ALL PHASES OF THE NORMAL & EMERGENCY SOURCES.

PARAMETER	RANGE OF SETTINGS	DEFAULT SETTING
NORMAL VOLTAGE DROPOUT	70-98%	85%
NORMAL VOLTAGE PICKUP	85-100%	90%
NORMAL OVER VOLTAGE TRIP	102-115%	OFF
NORMAL VOLTAGE UNBALANCE	YES/NO	NO
NORMAL VOLTAGE UNBALANCE DROPOUT	5-20% OF AVG. NORMAL VOLTAGE	20% (if ON)
NORMAL VOLTAGE UNBALANCE PICKUP	3-18% OF AVG. NORMAL VOLTAGE	10% (if ON)
EMERGENCY VOLTAGE DROPOUT	70-98%	75%
EMERGENCY VOLTAGE PICKUP	85-100%	90%
EMERGENCY OVER VOLTAGE TRIP	102-115%	OFF
EMERGENCY VOLTAGE UNBALANCE	YES/NO	NO
EMERGENCY VOLTAGE UNBALANCE DROPOUT	5-20% OF AVG. EMERGENCY VOLTAGE	20% (if ON)
EMERGENCY VOLTAGE UNBALANCE PICKUP	3-18% OF AVG. EMERGENCY VOLTAGE	10% (if ON)

B. FREQUENCY SENSING OF THE NORMAL & EMERGENCY SOURCES.

PARAMETER	RANGE OF SETTINGS	DEFAULT SETTING
NORMAL FREQUENCY DROPOUT	85-98%	90%
NORMAL FREQUENCY PICKUP	90-100%	95%
NORMAL OVER FREQUENCY TRIP	102-110%	OFF
EMERGENCY FREQUENCY DROPOUT	85-98%	90%
EMERGENCY FREQUENCY PICKUP	90-100%	95%
EMERGENCY OVER FREQUENCY TRIP	102-110%	OFF

### TIME DELAYS

THE FOLLOWING TIME DELAY SETTINGS ALL HAVE AN ADJUSTABLE RANGE OF 0-60 min 59 sec UNLESS STATED OTHERWISE. ADJUSTABLE IN INCREMENTS OF 1 sec.

NOTE: SOME TIME DELAYS MAY BE EFFECTED BY CUSTOMER REQUESTED ACCESSORIES PROVIDED WITH THE UNIT. REFER TO THE DESCRIPTIONS PROVIDED UNDER THE "ACCESSORIES" NOTES ON THIS PAGE.

FEATURE	NAME	DEFAULT SETTING
1C	NORMAL SOURCE FAILURE TO ENGINE START	1 sec
2B	TRANSFER TO EMERGENCY ON AVAILABILITY OF EMERGENCY SOURCE	0 sec
1F	EMERGENCY SOURCE FAILURE RETRANSFER (NORMAL SOURCE AVAILABLE)	0 sec
2E	ENGINE COOLDOWN FOLLOWING RETRANSFER TO NORMAL	5 min
3A	RETRANSFER TO NORMAL (NORMAL FAILURE MODE)	30 min
3A	RETRANSFER TO NORMAL (TEST MODE)	30 sec
-	DELAYED TRANSFER (LOAD "OFF" TIME), [0-5 min 59 sec]	3 sec

DESCRIPTIONS OF TIME DELAYS:

- FEAT. 1C - DELAY ON NORMAL SOURCE OUTAGE. STARTS ON FAILURE OF NORMAL SOURCE. RESETS IF NORMAL SOURCE IS ACCEPTED BEFORE EXPIRATION. INHIBITS ENGINE STARTING AND AUTOMATIC TRANSFER UNTIL EXPIRATION.
- FEAT. 2B - DELAY PRIOR TO TRANSFER TO THE EMERGENCY SOURCE. DELAY STARTS ON EXPIRATION OF FEAT. 1C AND WHEN THE EMERGENCY SOURCE HAS BEEN ACCEPTED. DELAY RESETS IF THE EMERGENCY SOURCE FAILS PRIOR TO EXPIRATION. ON EXPIRATION, TRANSFER TO EMERGENCY IS INITIATED UNLESS THE NORMAL SOURCE HAS RECOVERED AND THE "COMMIT TO TRANSFER" FEATURE IS SET TO "NO" COMMIT. PROVIDES A PERIOD FOR EMERGENCY SOURCE STABILIZATION OR STAGING OF MULTIPLE TRANSFER SWITCH CONTROLLED LOADS TO THE EMERGENCY SOURCE.
- FEAT. 1F - DELAY ON RETRANSFER TO NORMAL IN THE EVENT OF EMERGENCY SOURCE FAILURE. DELAY BEGINS ON FAILURE OF THE EMERGENCY SOURCE IF THE NORMAL SOURCE IS ACCEPTABLE. ON EXPIRATION, RETRANSFER TO NORMAL WILL BE INITIATED.
- FEAT. 2E - DELAY ON ENGINE SHUTDOWN (ENGINE COOL DOWN PERIOD). DELAY STARTS FOLLOWING RETRANSFER TO THE NORMAL SOURCE. PROVIDES A PERIOD FOR THE ENGINE-GENERATOR SET TO RUN UNLOADED PRIOR TO SHUTDOWN.
- FEAT. 3A - RETRANSFER TO NORMAL DELAY (NORMAL FAILURE MODE)  
DELAY STARTS WHEN NORMAL SOURCE IS ACCEPTED (FOLLOWING IT'S FAILURE) AND WHILE THE LOAD IS CONNECTED TO EMERGENCY. RESETS IF NORMAL FAILS PRIOR TO EXPIRATION OR IF THE EMERGENCY SOURCE FAILS BEFORE EXPIRATION AND FEAT. 1F EXPIRES (AUTOMATIC BYPASS ON EMERGENCY SOURCE FAILURE). PROVIDES A PERIOD FOR THE NORMAL SOURCE TO STABILIZE PRIOR TO RETRANSFER.
- FEAT. 3A - RETRANSFER TO NORMAL DELAY (TEST MODE)  
DELAY STARTS WHEN THE "TRANSFER TEST" SWITCH IS RESET TO "AUTO" (FOLLOWING A USER INITIATED TRANSFER TEST) AND WHILE THE LOAD IS CONNECTED TO EMERGENCY. RESETS IF NORMAL FAILS PRIOR TO EXPIRATION OR IF THE EMERGENCY SOURCE FAILS BEFORE EXPIRATION AND FEAT. 1F EXPIRES (AUTOMATIC BYPASS ON EMERGENCY SOURCE FAILURE).

### MOTOR LOAD TRANSFER FEATURE

- FEAT. 27 - INPHASE TRANSFER CONTROL LOGIC TO INITIATE AN INPHASE TRANSFER OF LOADS BETWEEN LIVE SOURCES. USED TO PREVENT NUISANCE TRIPPING OF CIRCUIT BREAKERS AND POSSIBLE DAMAGE TO MECHANICAL LOADS CAUSED BY OUT OF PHASE TRANSFER.
- ACTIVATED VIA THE GROUP 5 CONTROL PANEL USER INTERFACE (TRANSFER CONTROL CENTER) BY SELECTING "IN-PHASE MONITOR ENABLE" = YES. AN ADJUSTABLE DELAY (0.0-3.0 sec, FACTORY SET TO 1.5 sec, IN INCREMENTS OF 0.1 sec) DELAYS SENSING TO PERMIT STABILIZATION OF THE SOURCES PRIOR TO SENSING. FACTORY SETTING IS DISABLED UNLESS SPECIFIED TO BE FACTORY ACTIVATED AT THE TIME OF ORDER.

### ENGINE EXERCISER

THE ENGINE EXERCISER FEATURE PROVIDES A MEANS TO PERFORM AUTOMATIC EXERCISING OF THE ENGINE-GENERATOR SET EITHER WITH OR WITHOUT LOAD TRANSFER. THE USER CAN PROGRAM UP TO SEVEN DIFFERENT EXERCISE ROUTINES. EACH ROUTINE INCLUDES:

1. ENABLE OR DISABLE THE ROUTINE
2. ENABLE OR DISABLE TRANSFER OF THE LOAD DURING THE ROUTINE
3. SET START TIME OF ROUTINE -  
- TIME OF DAY  
- DAY OF WEEK  
- WEEK OF MONTH (1st, 2nd, 3rd, 4th, ALTERNATE OR ALL)
4. SET THE DURATION OF THE ROUTINE

PARAMETER	RANGE OF SETTING	DEFAULT SETTING
MONTH (CLOCK SET)	JAN FEB MAR APR MAY JUN JUL AUG SEP OCT NOV DEC	CURRENT DATE
DAY	1-31	↓
YEAR	00-99	↓
HOUR	0-23	Eastern Standard Time
MINUTE	0-59	↓
ENABLE ROUTINE (ROUTINE 1-7)	YES/NO	NO
TRANSFER LOAD	YES/NO	NO
START HOUR	0-23	0
START MINUTE	0-59	0
RUN WEEK	ALL, ALTERNATE, 1st, 2nd, 3rd, 4th, 5th	ALL
RUN DAY	SUN MON TUE WED THU FRI SAT	SUN
DURATION HOURS	0-23	0
DURATION MINUTES	0-59	0

### SIGNALS & AUXILIARIES

- A. FEATURES 7 & 8- ENGINE START SIGNAL  
SIGNAL INITIATED BY DROPOUT OF CONTROL PANEL RELAY (NR) FOLLOWING EXPIRATION OF THE FEATURE 1C TIME DELAY (DELAY TO OVERRIDE MOMENTARY NORMAL SOURCE OUTAGES). FEATURE 7 CLOSING TO SIGNAL ENGINE START. FEATURE 8 OPENS TO SIGNAL ENGINE START. ENGINE STARTING SIGNAL RESETS FOLLOWING RETRANSFER TO THE NORMAL SOURCE AND EXPIRATION OF THE FEATURE 2E (ENGINE COOL DOWN) TIME DELAY. FEATURES 7 & 8 ARE PROVIDED AS A SINGLE FORM C CONTACT CONNECTED TO THE FIELD CONNECTIONS TERMINAL BLOCK (TB). CONTACT RATED 5 AMPS AT 32 VDC/120VAC RESISTIVE.

- B. FEATURES 14AG & 14BG - TRANSFER SWITCH AUXILIARY POSITION INDICATING CONTACTS. EIGHT (8) FORM C CONTACTS TO INDICATE CONNECTION OF THE TRANSFER SWITCH TO NORMAL (14A) OR EMERGENCY (14B). CONTACTS CONNECTED TO THE FIELD CONNECTIONS TERMINAL BLOCK (TB). CONTACTS RATED 10 AMPS, 32 VDC, 250 VAC.

- C. FEATURE 17 - REMOTE TRANSFER TO EMERGENCY.  
REQUIRES A CUSTOMER SUPPLIED NORMALLY OPEN CONTACT. CLOSING OF THE CONTACT CAUSES ENGINE START AND TRANSFER TO THE EMERGENCY SOURCE. OPENING OF THE CONTACT ACTIVATES THE FEATURE 3A (RETRANSFER TO NORMAL) DELAY PRIOR TO RETRANSFER. IN THE EVENT THE EMERGENCY SOURCE FAILS WHILE THE TRANSFER SWITCH IS CONNECTED TO EMERGENCY AND THE REMOTE CONTACT IS CLOSED, THE TRANSFER SWITCH WILL RETRANSFER TO THE NORMAL SOURCE. CONNECTED TO THE FIELD CONNECTIONS TERMINAL BLOCK (TB).

### OPERATION

IF THE NORMAL SOURCE FAILS, THE TRANSFER SWITCH INITIATES STARTING OF THE ENGINE-GENERATOR SET. WHEN PROPER VOLTAGE AND FREQUENCY HAVE BEEN ATTAINED, THE LOAD WILL BE TRANSFERRED TO THE EMERGENCY SOURCE.

WHEN THE NORMAL SOURCE IS RESTORED FOR THE DURATION OF THE FEATURE 3A (RETRANSFER TO NORMAL) TIME DELAY SETTING, THE LOAD WILL BE RETRANSFERRED TO THE NORMAL SOURCE.

THE ENGINE WILL CONTINUE TO RUN FOR THE ENGINE COOL DOWN PERIOD, FEATURE 2E.

### USER CONTROLS AND INDICATIONS

- A. FEATURES 5 & 6B - TRANSFER TEST/RETRANSFER TIME DELAY BYPASS CONTROLS.

**TRANSFER TEST:**  
OPERATION CAUSES A NORMAL SOURCE FAILURE SEQUENCE. ACTIVATE AND HOLD FOR AT LEAST 15 SECONDS TO ALLOW TIME FOR THE ENGINE-GENERATOR TO START.

**RETRANSFER TIME DELAY BYPASS:**  
OPERATION WILL BYPASS THE FEATURE 3A (RETRANSFER TO NORMAL DELAY).

- B. FEATURES 9A & 9B - TRANSFER SWITCH POSITION INDICATORS.  
FEATURE 9A: TRANSFER SWITCH CLOSED ON NORMAL (GREEN LED)  
FEATURE 9B: TRANSFER SWITCH CLOSED ON EMERGENCY (RED LED)

- C. FEATURES 9C & 9D - SOURCE ACCEPTANCE INDICATORS.  
FEATURE 9C: NORMAL SOURCE ACCEPTED (GREEN LED)  
FEATURE 9D: EMERGENCY SOURCE ACCEPTED (RED LED)

### GENERAL NOTES

1. SWITCH SHOWN DE-ENERGIZED AND CONNECTED TO THE NORMAL SOURCE.
2. DEVICE SYMBOLS AND DESIGNATIONS ARE IN ACCORDANCE WITH NEMA PUBLICATION ICS 1-1983, PART 1-101A.
3. ALL WIRING IS #16 AWG, TINNED, STRANDED COPPER UNLESS OTHERWISE INDICATED.
4. ○ ON TERMINAL BLOCKS INDICATES AVAILABLE FIELD CONNECTION POINT.
5. ● ON TERMINAL BLOCKS INDICATES FACTORY CONNECTION POINT.
6. CONTROL AND ACCESSORY WIRING IS ROUTED IN ACCORDANCE WITH ASCO ASSEMBLY PROCEDURE GS451261.
7. AN OPERATOR'S MANUAL IS FURNISHED WITH EACH AUTOMATIC TRANSFER SWITCH. REFER TO THIS PUBLICATION PRIOR TO INSTALLATION AND OPERATION OF THE UNIT.

BASE CATALOG NUMBER				CATALOG NUMBER SUFFIXES				EXPLANATION OF CATALOG NUMBER CODES												
TS FRAME	CATALOG TYPE	NEUTRAL TYPE	PHASE POLES	AMPS	VOLT CODE	CONTROLLER	OPTIONAL ACCESSORY	ENCLOSURE CODE	NEUTRAL TYPE			VOLTAGE CODES 3 PHASE (3 OR 4 WIRE) 50 OR 60 Hz			ENCLOSURE CODES					
									CODE	DESCRIPTION	CODE	NOMINAL VOLTAGE	CODE	TYPE	DESCRIPTION					
									BLANK	NONE			BLANK		OPEN TYPE (NO ENCLOSURE) GENERAL PURPOSE, INDOOR					
									A	SOLID			C	1	INDOOR, WATER & DUST RESISTANT					
									B	SWITCHING	C	208	E	2	OUTDOOR, RAINPROOF, SLEET & ICE RESISTANT					
									C	OVERLAPPING	D	220	F	3R	INDOOR/OUTDOOR, WATERTIGHT & DUSTTIGHT					
											E	230	G	4	TYPE 4 PLUS CORROSION RESISTANCE (STAINLESS STEEL)					
											F	240	H	4X	TYPE 4 PLUS CORROSION RESISTANCE (FIBERGLASS)					
													J	4X	EXPLOSION PROOF					
											H	380	K	7	INDOOR, INDUSTRIAL ENVIRONMENTS, OILTIGHT & DUSTTIGHT					
											J	400	L	12						
											K	415								
											L	440								
											M	460	M	3R	(SECURE ENCLOSURES)					
											N	480	N	4	OUTDOOR, RAINPROOF, SLEET & ICE RESISTANT					
											P	550	P	4X	INDOOR/OUTDOOR, WATERTIGHT & DUSTTIGHT					
											Q	575	Q	12	TYPE 4 PLUS CORROSION RESISTANCE (STAINLESS STEEL)					
											R	600	Q		INDOOR, INDUSTRIAL ENVIRONMENTS, OILTIGHT & DUSTTIGHT					
															INDOOR, INDUSTRIAL ENVIRONMENTS, OILTIGHT & DUSTTIGHT					

CATALOG NUMBER \_\_\_\_\_

CERTIFIED TO

**ASCO**® S.O. \_\_\_\_\_

BY \_\_\_\_\_

DATE \_\_\_\_\_

FORM REV A

PROJECT NAME: \_\_\_\_\_

WIRING \_\_\_\_\_ DIAGRAM \_\_\_\_\_

7000 SERIES (J7ATS)

GROUP 5 CONTROLS

THIRD ANGLE PROJECTION

MANUFACTURING TOLERANCES TO BE IN ACCORDANCE WITH ASCO PROCEDURE MP-1-003. FOR PLASTIC PARTS SEE MP-1-055.

PROPERTY OF ASCO POWER TECHNOLOGIES. USE PERMITTED FOR OUR WORK ONLY. ALL RIGHTS OF DESIGN OR INVENTION ARE RESERVED.

ASCO POWER TECHNOLOGIES, L.P.  
FLORHAM PARK, NEW JERSEY 07932 U.S.A.

CHANGE LETTER \_\_\_\_\_

ECN NO. 204462

SHEET 1 OF 6

A	204462	BWM	SDH	5/05
	SEE ECN			

-	204020	BWM	SDH	4/05
	ISSUE			

CHANGE LETTER	ECN NO.	BY	APP.	DATE

SUBSIDIARY DISTRIBUTION							
AE	<input type="checkbox"/>	AN	<input type="checkbox"/>	AM	<input type="checkbox"/>	AJ	<input type="checkbox"/>
AL	<input type="checkbox"/>	AR	<input type="checkbox"/>	AS	<input type="checkbox"/>	AT	<input type="checkbox"/>
AV	<input type="checkbox"/>	AA	<input type="checkbox"/>	PS	<input type="checkbox"/>	AR	<input type="checkbox"/>
AG	<input type="checkbox"/>	AP	<input type="checkbox"/>	AC	<input type="checkbox"/>	AS	<input type="checkbox"/>

COMPUTER GENERATED DRAWING			
SCALE	1:1	ACAD	FILE

SIZE	DWG. NO.	FILE
DS	775443	

CHANGE LETTER	ECN NO.	SHEET
	204462	1 OF 6

# FIELD CONNECTIONS

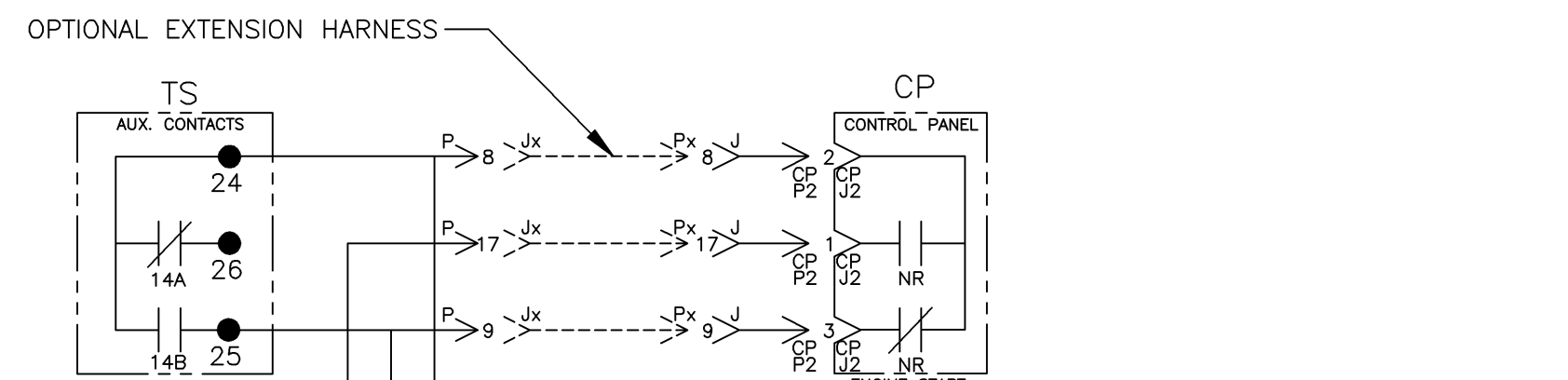

LOCATED AT UPPER RIGHT SIDE OF ENCLOSED UNITS  
 TB (FIELD CONNECTIONS), WIRE RANGE: 22-12 AWG

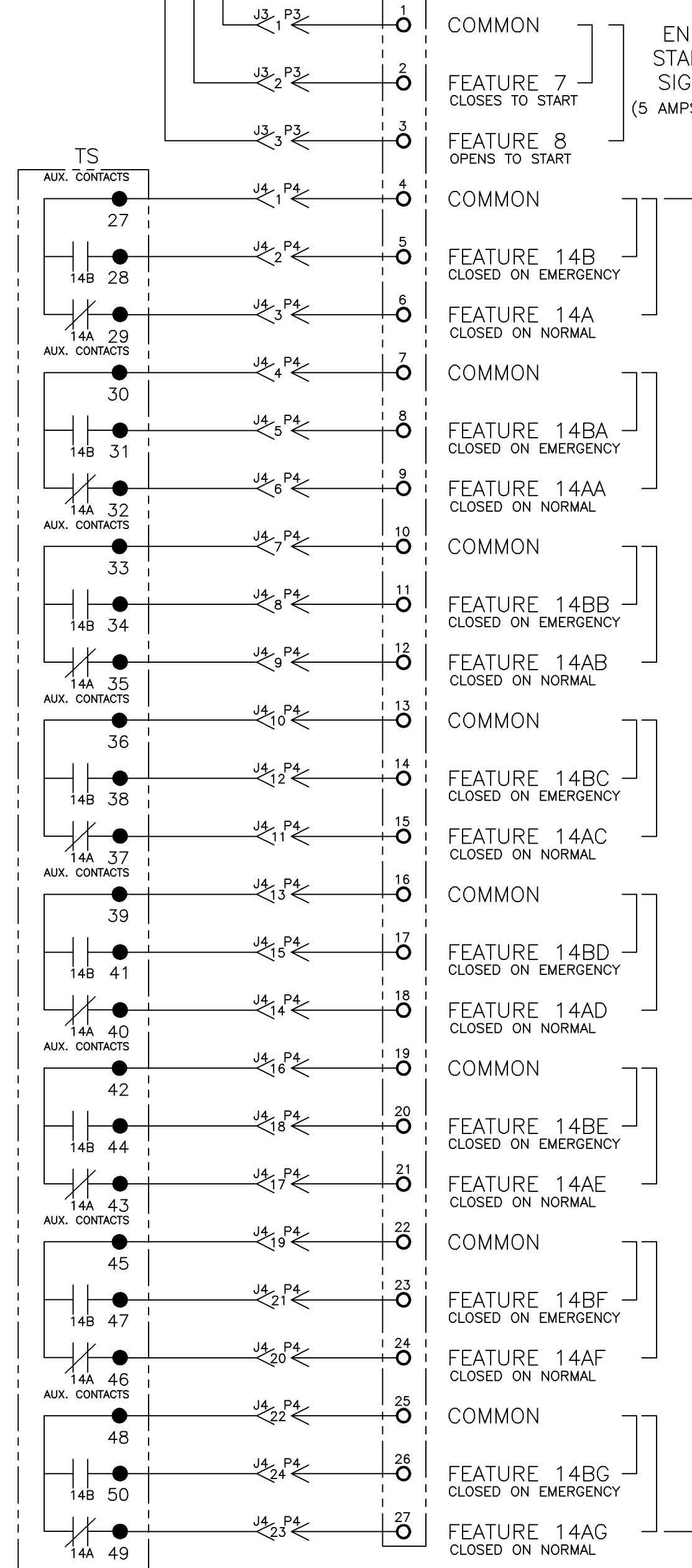

ENGINE STARTING SIGNALS  
 (5 AMPS, 32VDC)

TS AUXILIARY CONTACTS  
 (10 AMPS, 32VDC)  
 (10 AMPS, 250VAC)  
 GENERAL PURPOSE

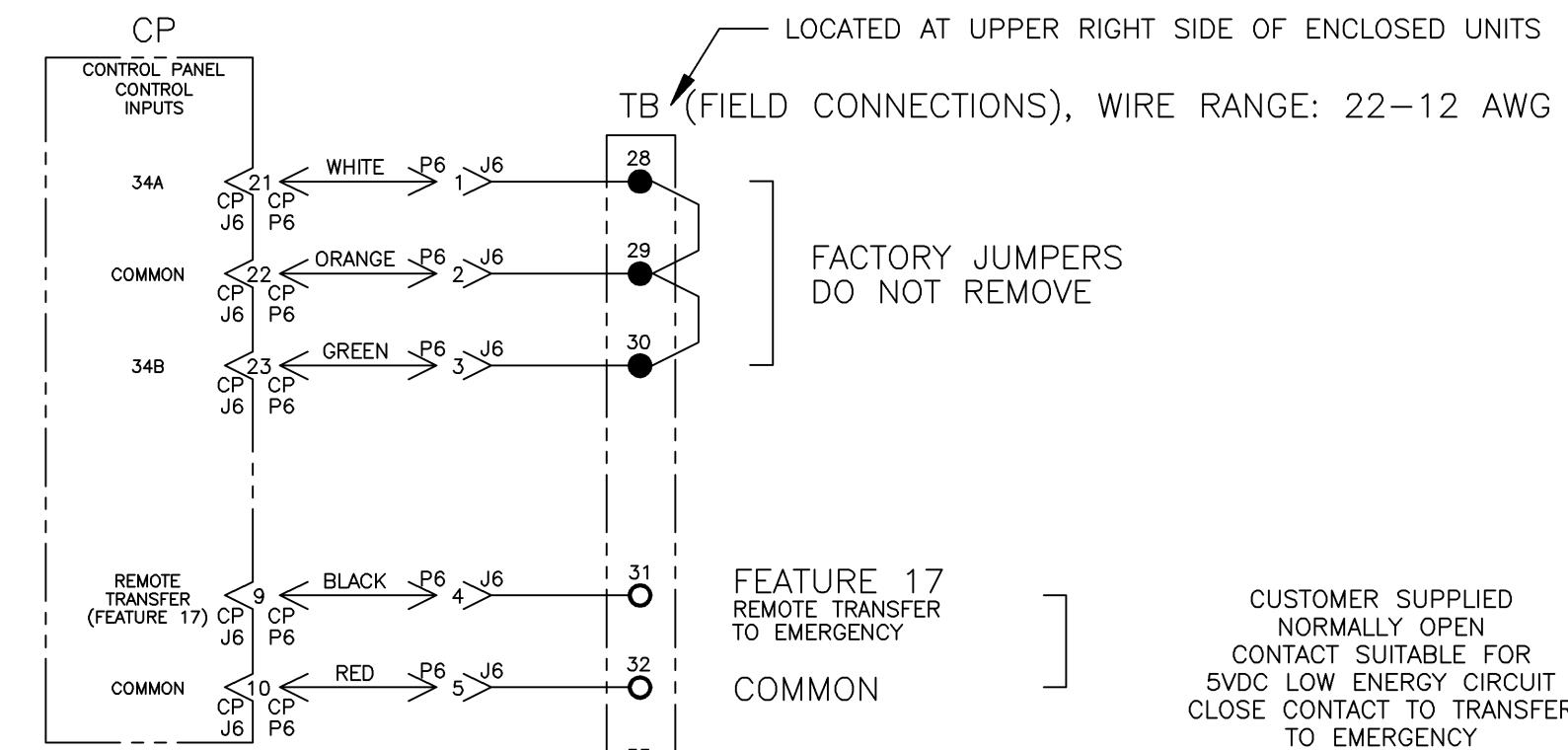

LOCATED AT UPPER RIGHT SIDE OF ENCLOSED UNITS  
 TB (FIELD CONNECTIONS), WIRE RANGE: 22-12 AWG

FACTORY JUMPERS DO NOT REMOVE

CUSTOMER SUPPLIED NORMALLY OPEN CONTACT SUITABLE FOR 5VDC LOW ENERGY CIRCUIT CLOSE CONTACT TO TRANSFER TO EMERGENCY

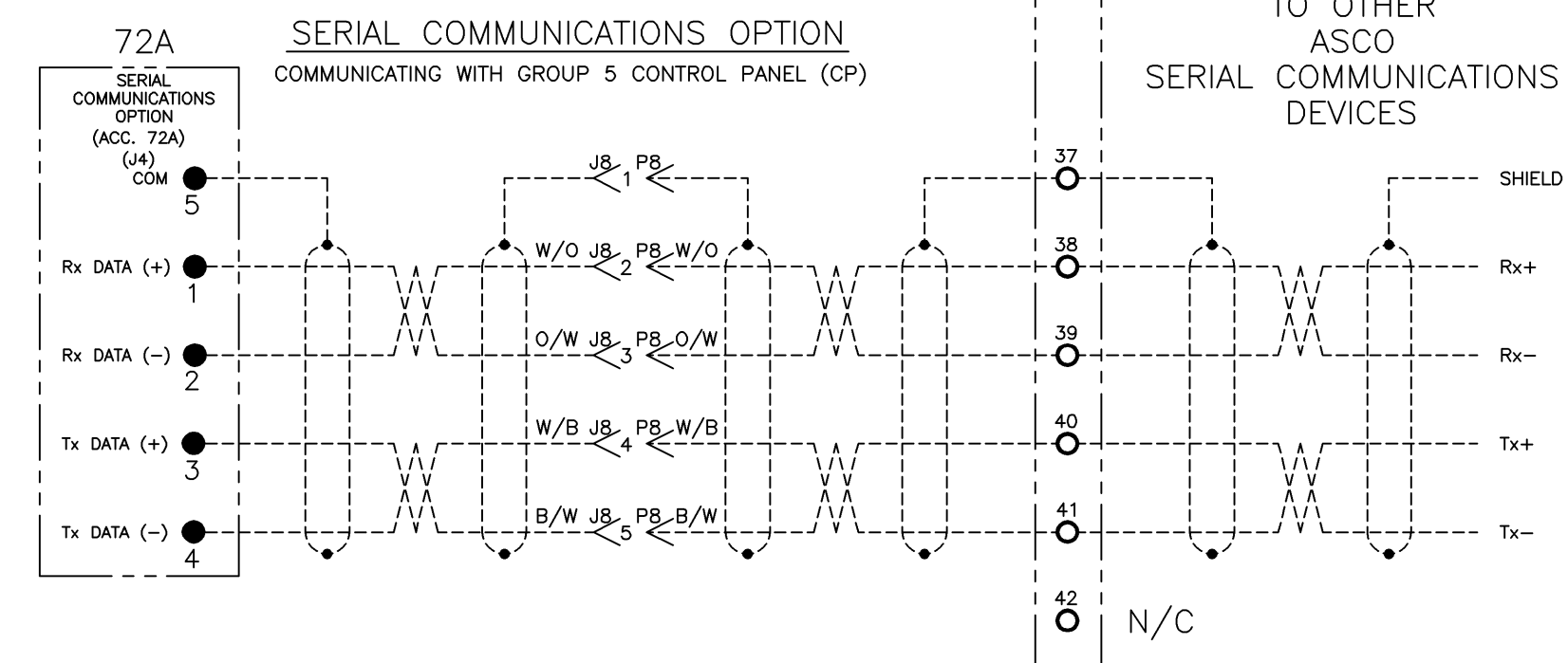

72A NOTES:  
 1. EARTH GROUND SHIELD AT HOST DEVICE ONLY.  
 2. FIELD WIRING: USE UL LISTED, STRANDED, TWISTED PAIRS, OVERALL FOIL SHIELD WITH STRANDED DRAIN WIRE SUITABLE FOR RS-422 EQUIVALENT TO:  
 (STANDARD 80°C) BELDEN 9842 OR 9829 OR ALPHA 6202C OR 6222C  
 (PLENUM RATED) BELDEN 89729 OR 82729 OR ALPHA 58902

TO OTHER ASCO SERIAL COMMUNICATIONS DEVICES

A	204462	BWM	SDH	5/05
	SEE ECN			
	204020	BWM	SDH	4/05
	ISSUE			

PROJECT NAME:		WIRING DIAGRAM		THIRD ANGLE PROJECTION	
7000 SERIES (J7ATS) GROUP 5 CONTROLS		COMPUTER GENERATED DRAWING		SCALE 1:1 ACAD FILE	
DRAWN BY	BY	DATE	MANUFACTURING TOLERANCES TO BE IN ACCORDANCE WITH ASCO PROCEDURE MP-1-003. FOR PLASTIC PARTS SEE MP-1-055	ASSEM. REF. NO.	SIZE
CHECKED	BWM	4/05			1:1
DRAFTING APPROVAL			PROPERTY OF ASCO POWER TECHNOLOGIES. USE PERMITTED FOR OUR WORK ONLY. ALL RIGHTS OF DESIGN OR INVENTION ARE RESERVED.		DWG. NO.
FINAL APPROVAL	SDH	4/05	<b>ASCO</b> ASCO POWER TECHNOLOGIES, L.P. FLORHAM PARK, NEW JERSEY 07932 U.S.A.		DS775443
				CHANGE LETTER	ECN NO. 204462
					SHEET 2 OF 6

MAIN POWER POLES

TS OPERATOR CIRCUIT

EMERGENCY

NORMAL

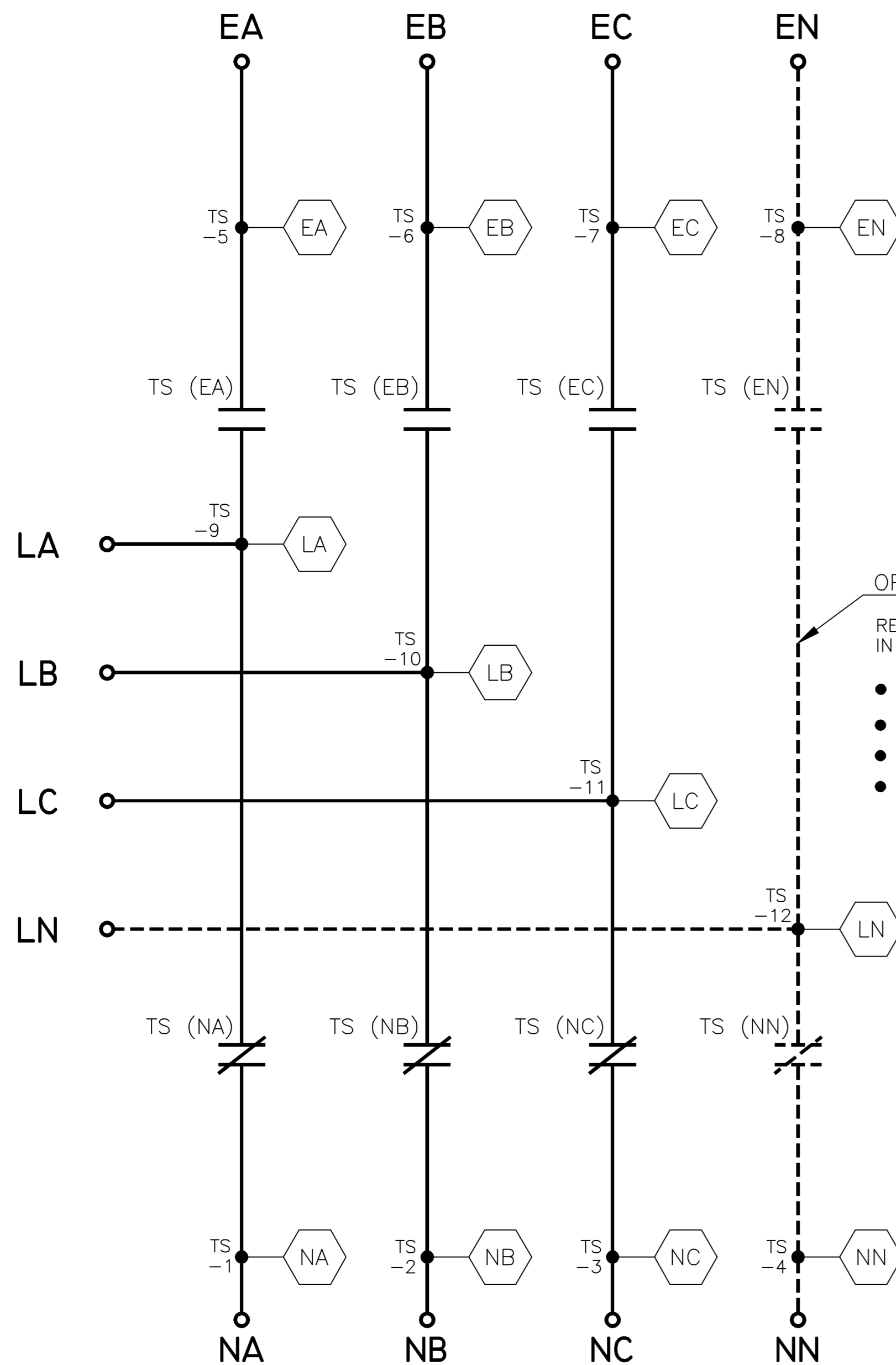

OPTIONAL NEUTRAL TYPES  
 REFER TO "EXPLANATION OF CATALOG NUMBER CODES"  
 IN CATALOG NUMBER CHART ON SHEET 1.

- NONE
- SWITCHING CONTACTS
- OVERLAPPING CONTACTS
- SOLID BUS PLATE

NORMAL

EMERGENCY

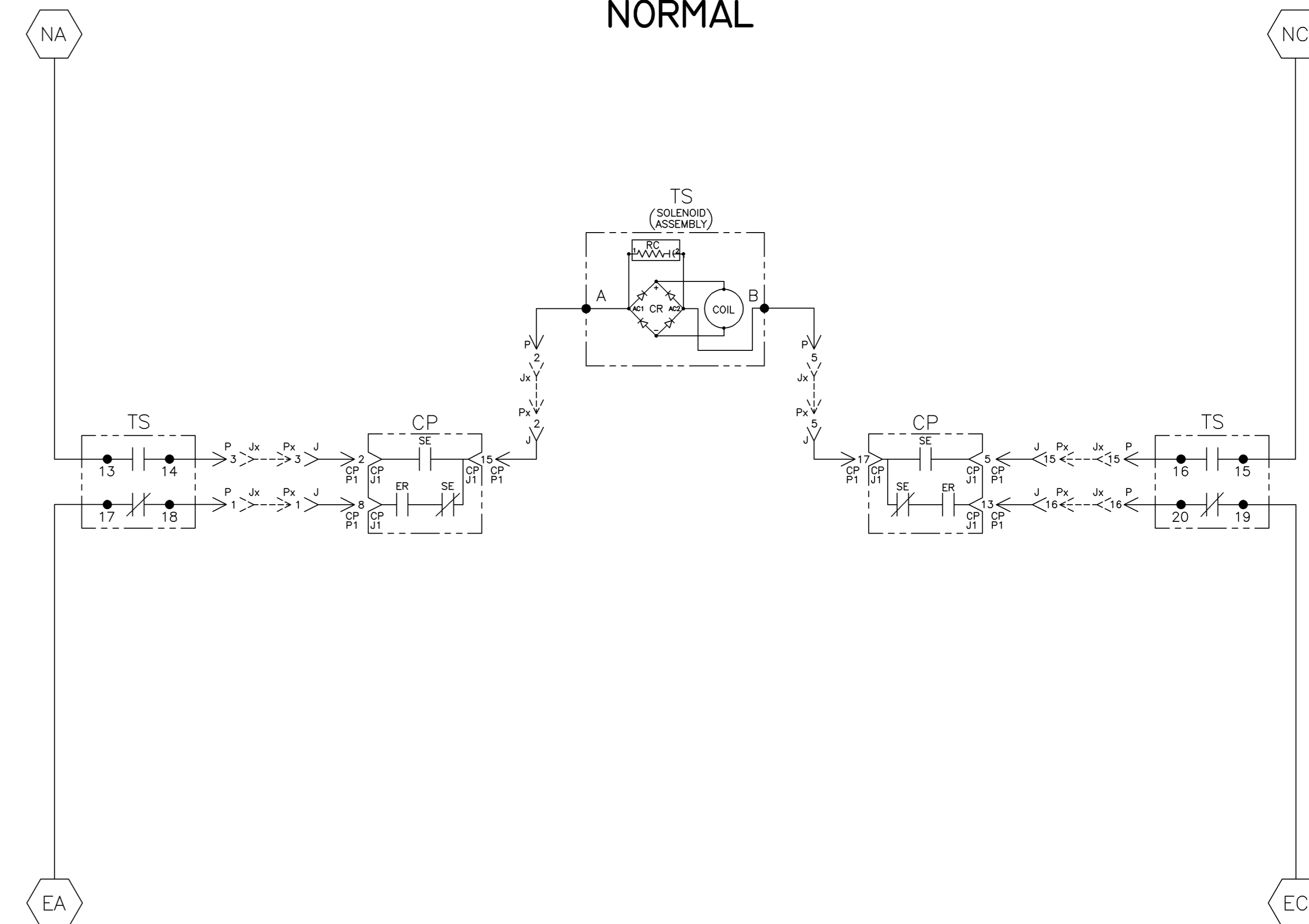

NOTE:  
 ATS SHOWN CLOSED ON NORMAL SOURCE.

TS	SOLENOID POSITION			
	CLOSED	BEFORE	BEFORE	CLOSED
	NORMAL	TDC	TDC	EMERG
13-14				
15-16				
17-18				
19-20				

TDC (TOP DEAD CENTER)  
 TRANSFER SWITCH TEST & ADJUSTMENT PROCEDURE  
 SPECIFIES CONTROL CUT-OFF (CONTACT OPENING)  
 SETTING.

PROJECT NAME:		WIRING DIAGRAM		THIRD ANGLE PROJECTION	
7000 SERIES (J7ATS)		GROUP 5 CONTROLS		COMPUTER GENERATED DRAWING	
SCALE	1:1	ACAD	FILE	SIZE DWG. NO.	
DRAWN BY		DATE		ASSEMBLY REF. NO.	
CHECKED		DATE		PROPERTY OF ASCO POWER TECHNOLOGIES, USE PERMITTED FOR OUR WORK ONLY. ALL RIGHTS OF DESIGN OR INVENTION ARE RESERVED.	
DRAWING APPROVAL		DATE		ASSEMBLY REF. NO.	
FINAL APPROVAL		DATE		ASSEMBLY REF. NO.	
ASCO		ASCO POWER TECHNOLOGIES, L.P.		FLORHAM PARK, NEW JERSEY 07932 U.S.A.	
CHANGE LETTER	ECN NO.	BY	APP.	DATE	ISSUE
A	204462	BWM	SDH	5/05	SEE ECN
	204020	BWM	SDH	4/05	ISSUE
SUBSIDIARY DISTRIBUTION		AE		AN	AM
		AJ		AL	AL
		AV		AA	PS
		AP		AC	AS
		AR		AR	AR
		AS		AS	AS
DS		775443		SHEET 3 OF 6	
CHANGE LETTER		ECN NO.		204462	

EMERGENCY SOURCE CIRCUITS

ADDITIONAL CIRCUITS

EMERGENCY

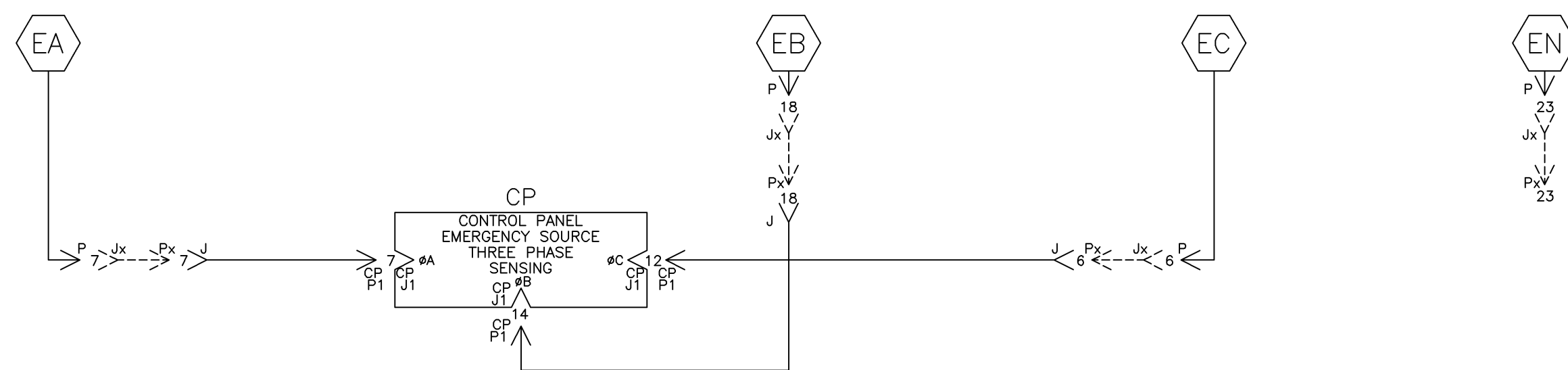

LOAD TERMINAL CIRCUITS

LOAD



NORMAL SOURCE CIRCUITS

NORMAL

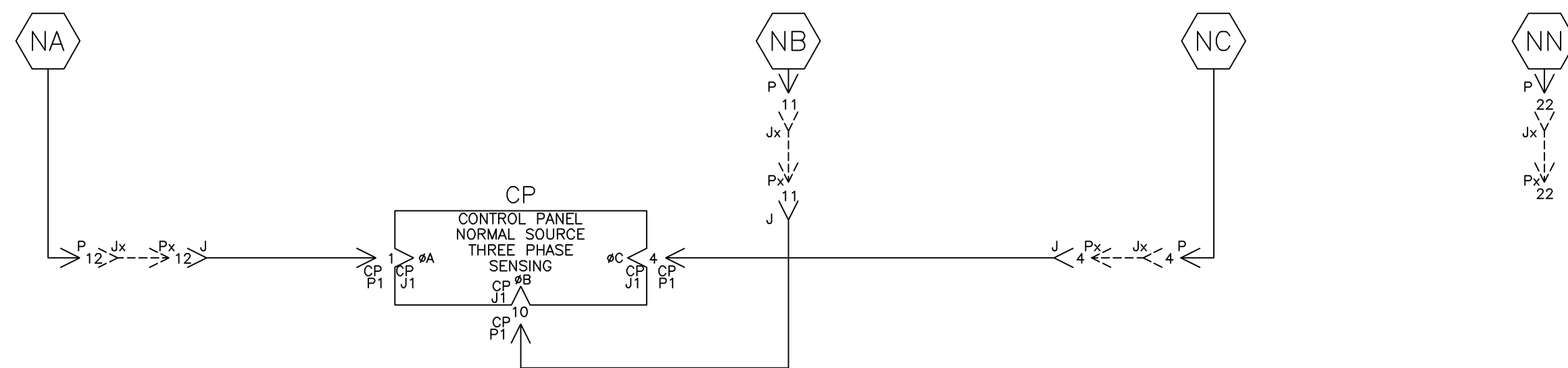

CONTROL CIRCUITS

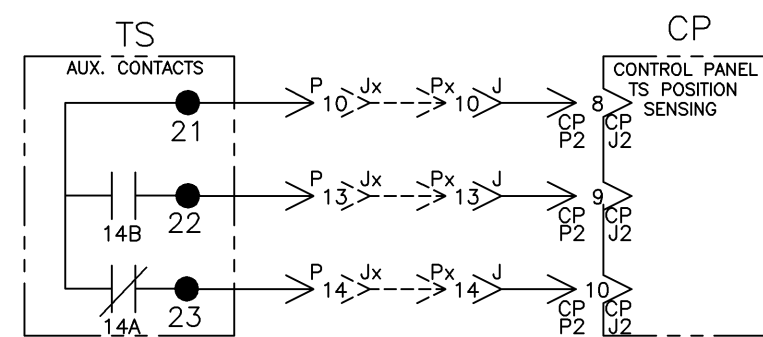

PROJECT NAME:		WIRING DIAGRAM		THIRD ANGLE PROJECTION	
7000 SERIES (J7ATS)		GROUP 5 CONTROLS		COMPUTER GENERATED DRAWING	
BY	DATE	MANUFACTURING TOLERANCES TO BE IN ACCORDANCE WITH ASCO PROCEDURE MP-I-003. FOR PLASTIC PARTS SEE MP-I-055.		ASSEM. REF. NO.	
DRAWN BY	BWM	4/05			
CHECKED			PROPERTY OF ASCO POWER TECHNOLOGIES. USE PERMITTED FOR OUR WORK ONLY. ALL RIGHTS OF DESIGN OR INVENTION ARE RESERVED.		SCALE 1:1 ACAD FILE
DRAFTING APPROVAL					SIZE DWG. NO. DS775443
FINAL APPROVAL	SDH	4/05	ASCO POWER TECHNOLOGIES, L.P. FLORHAM PARK, NEW JERSEY 07932 U.S.A.		CHANGE LETTER A
A		204462	BWM	SDH	5/05
-		204020	BWM	SDH	4/05
-		ISSUE		SUBSIDIARY DISTRIBUTION	
AE	AN	AM	AJ	AL	
CH	AV	AA	PS	AR	
AG	AP	AC	AS		
CHANGE LETTER		ECN NO.	BY	APP.	DATE
A		204462	BWM	SDH	5/05
-		204020	BWM	SDH	4/05
-		ISSUE		SUBSIDIARY DISTRIBUTION	
AE	AN	AM	AJ	AL	
CH	AV	AA	PS	AR	
AG	AP	AC	AS		
CHANGE LETTER		ECN NO.	BY	APP.	DATE
A		204462	BWM	SDH	5/05
-		204020	BWM	SDH	4/05
-		ISSUE		SUBSIDIARY DISTRIBUTION	
AE	AN	AM	AJ	AL	
CH	AV	AA	PS	AR	
AG	AP	AC	AS		
CHANGE LETTER		ECN NO.	BY	APP.	DATE
A		204462	BWM	SDH	5/05
-		204020	BWM	SDH	4/05
-		ISSUE		SUBSIDIARY DISTRIBUTION	
AE	AN	AM	AJ	AL	
CH	AV	AA	PS	AR	
AG	AP	AC	AS		
CHANGE LETTER		ECN NO.	BY	APP.	DATE
A		204462	BWM	SDH	5/05
-		204020	BWM	SDH	4/05
-		ISSUE		SUBSIDIARY DISTRIBUTION	
AE	AN	AM	AJ	AL	
CH	AV	AA	PS	AR	
AG	AP	AC	AS		
CHANGE LETTER		ECN NO.	BY	APP.	DATE
A		204462	BWM	SDH	5/05
-		204020	BWM	SDH	4/05
-		ISSUE		SUBSIDIARY DISTRIBUTION	
AE	AN	AM	AJ	AL	
CH	AV	AA	PS	AR	
AG	AP	AC	AS		
CHANGE LETTER		ECN NO.	BY	APP.	DATE
A		204462	BWM	SDH	5/05
-		204020	BWM	SDH	4/05
-		ISSUE		SUBSIDIARY DISTRIBUTION	
AE	AN	AM	AJ	AL	
CH	AV	AA	PS	AR	
AG	AP	AC	AS		
CHANGE LETTER		ECN NO.	BY	APP.	DATE
A		204462	BWM	SDH	5/05
-		204020	BWM	SDH	4/05
-		ISSUE		SUBSIDIARY DISTRIBUTION	
AE	AN	AM	AJ	AL	
CH	AV	AA	PS	AR	
AG	AP	AC	AS		
CHANGE LETTER		ECN NO.	BY	APP.	DATE
A		204462	BWM	SDH	5/05
-		204020	BWM	SDH	4/05
-		ISSUE		SUBSIDIARY DISTRIBUTION	
AE	AN	AM	AJ	AL	
CH	AV	AA	PS	AR	
AG	AP	AC	AS		
CHANGE LETTER		ECN NO.	BY	APP.	DATE
A		204462	BWM	SDH	5/05
-		204020	BWM	SDH	4/05
-		ISSUE		SUBSIDIARY DISTRIBUTION	
AE	AN	AM	AJ	AL	
CH	AV	AA	PS	AR	
AG	AP	AC	AS		
CHANGE LETTER		ECN NO.	BY	APP.	DATE
A		204462	BWM	SDH	5/05
-		204020	BWM	SDH	4/05
-		ISSUE		SUBSIDIARY DISTRIBUTION	
AE	AN	AM	AJ	AL	
CH	AV	AA	PS	AR	
AG	AP	AC	AS		
CHANGE LETTER		ECN NO.	BY	APP.	DATE
A		204462	BWM	SDH	5/05
-		204020	BWM	SDH	4/05
-		ISSUE		SUBSIDIARY DISTRIBUTION	
AE	AN	AM	AJ	AL	
CH	AV	AA	PS	AR	
AG	AP	AC	AS		
CHANGE LETTER		ECN NO.	BY	APP.	DATE
A		204462	BWM	SDH	5/05
-		204020	BWM	SDH	4/05
-		ISSUE		SUBSIDIARY DISTRIBUTION	
AE	AN	AM	AJ	AL	
CH	AV	AA	PS	AR	
AG	AP	AC	AS		
CHANGE LETTER		ECN NO.	BY	APP.	DATE
A		204462	BWM	SDH	5/05
-		204020	BWM	SDH	4/05
-		ISSUE		SUBSIDIARY DISTRIBUTION	
AE	AN	AM	AJ	AL	
CH	AV	AA	PS	AR	
AG	AP	AC	AS		
CHANGE LETTER		ECN NO.	BY	APP.	DATE
A		204462	BWM	SDH	5/05
-		204020	BWM	SDH	4/05
-		ISSUE		SUBSIDIARY DISTRIBUTION	
AE	AN	AM	AJ	AL	
CH	AV	AA	PS	AR	
AG	AP	AC	AS		
CHANGE LETTER		ECN NO.	BY	APP.	DATE
A		204462	BWM	SDH	5/05
-		204020	BWM	SDH	4/05
-		ISSUE		SUBSIDIARY DISTRIBUTION	
AE	AN	AM	AJ	AL	
CH	AV	AA	PS	AR	
AG	AP	AC	AS		
CHANGE LETTER		ECN NO.	BY	APP.	DATE
A		204462	BWM	SDH	5/05
-		204020	BWM	SDH	4/05
-		ISSUE		SUBSIDIARY DISTRIBUTION	
AE	AN	AM	AJ	AL	
CH	AV	AA	PS	AR	
AG	AP	AC	AS		
CHANGE LETTER		ECN NO.	BY	APP.	DATE
A		204462	BWM	SDH	5/05
-		204020	BWM	SDH	4/05
-		ISSUE		SUBSIDIARY DISTRIBUTION	
AE	AN	AM	AJ	AL	
CH	AV	AA	PS	AR	
AG	AP	AC	AS		
CHANGE LETTER		ECN NO.	BY	APP.	DATE
A		204462	BWM	SDH	5/05
-		204020	BWM	SDH	4/05
-		ISSUE		SUBSIDIARY DISTRIBUTION	
AE	AN	AM	AJ	AL	
CH	AV	AA	PS	AR	
AG	AP	AC	AS		
CHANGE LETTER		ECN NO.	BY	APP.	DATE
A		204462	BWM	SDH	5/05
-		204020	BWM	SDH	4/05
-		ISSUE		SUBSIDIARY DISTRIBUTION	
AE	AN	AM	AJ	AL	
CH	AV	AA	PS	AR	
AG	AP	AC	AS		
CHANGE LETTER		ECN NO.	BY	APP.	DATE
A		204462	BWM	SDH	5/05
-		204020	BWM	SDH	4/05
-		ISSUE		SUBSIDIARY DISTRIBUTION	
AE	AN	AM	AJ	AL	
CH	AV	AA	PS	AR	
AG	AP	AC	AS		
CHANGE LETTER		ECN NO.	BY	APP.	DATE
A		204462	BWM	SDH	5/05
-		204020	BWM	SDH	4/05
-		ISSUE		SUBSIDIARY DISTRIBUTION	
AE	AN	AM	AJ	AL	
CH	AV	AA	PS	AR	
AG	AP	AC	AS		
CHANGE LETTER		ECN NO.	BY	APP.	DATE
A		204462	BWM	SDH	5/05
-		204020	BWM	SDH	4/05
-		ISSUE		SUBSIDIARY DISTRIBUTION	
AE	AN	AM	AJ	AL	
CH	AV	AA	PS	AR	
AG	AP	AC	AS		
CHANGE LETTER		ECN NO.	BY	APP.	DATE
A		204462	BWM	SDH	5/05
-		204020	BWM	SDH	4/05
-		ISSUE		SUBSIDIARY DISTRIBUTION	
AE	AN	AM	AJ	AL	
CH	AV	AA	PS	AR	
AG	AP	AC	AS		
CHANGE LETTER		ECN NO.	BY	APP.	DATE
A		204462	BWM	SDH	5/05
-		204020	BWM	SDH	4/05
-		ISSUE		SUBSIDIARY DISTRIBUTION	
AE	AN	AM	AJ	AL	
CH	AV	AA	PS	AR	
AG	AP	AC	AS		
CHANGE LETTER		ECN NO.	BY	APP.	DATE
A		204462	BWM	SDH	5/05
-		204020	BWM	SDH	4/05
-		ISSUE		SUBSIDIARY DISTRIBUTION	
AE	AN	AM	AJ	AL	
CH	AV	AA	PS	AR	
AG	AP	AC	AS		
CHANGE LETTER		ECN NO.	BY	APP.	DATE
A		204462	BWM	SDH	5/05
-		204020	BWM	SDH	4/05
-		ISSUE		SUBSIDIARY DISTRIBUTION	
AE	AN	AM	AJ	AL	
CH	AV	AA	PS	AR	
AG	AP	AC	AS		
CHANGE LETTER		ECN NO.	BY	APP.	DATE
A		204462	BWM	SDH	5/05
-		204020	BWM	SDH	4/05
-		ISSUE		SUBSIDIARY DISTRIBUTION	
AE	AN	AM	AJ	AL	
CH	AV	AA	PS	AR	
AG	AP	AC	AS		
CHANGE LETTER		ECN NO.	BY	APP.	DATE
A		204462	BWM	SDH	5/05
-		204020	BWM	SDH	4/05
-		ISSUE		SUBSIDIARY DISTRIBUTION	
AE	AN	AM	AJ	AL	
CH	AV	AA	PS	AR	
AG	AP	AC	AS		
CHANGE LETTER		ECN NO.	BY	APP.	DATE
A		204462	BWM	SDH	5/05
-		204020	BWM	SDH	4/05
-		ISSUE		SUBSIDIARY DISTRIBUTION	
AE	AN	AM	AJ	AL	
CH	AV	AA	PS	AR	
AG	AP	AC	AS		
CHANGE LETTER		ECN NO.	BY	APP.	DATE
A		204462	BWM	SDH	5/05
-		204020	BWM	SDH	4/05
-		ISSUE		SUBSIDIARY DISTRIBUTION	
AE	AN	AM	AJ	AL	
CH	AV	AA	PS	AR	
AG	AP	AC	AS		
CHANGE LETTER		ECN NO.	BY	APP.	DATE
A		204462	BWM	SDH	5/05
-		204020	BWM	SDH	4/05
-		ISSUE		SUBSIDIARY DISTRIBUTION	
AE	AN	AM	AJ	AL	
CH	AV	AA	PS	AR	
AG	AP	AC	AS		
CHANGE LETTER		ECN NO.	BY	APP.	DATE
A		204462	BWM	SDH	5/05
-		204020	BWM	SDH	4/05
-		ISSUE		SUBSIDIARY DISTRIBUTION	
AE	AN	AM	AJ	AL	
CH	AV	AA	PS	AR	
AG	AP	AC	AS		
CHANGE LETTER		ECN NO.			

PHYSICAL DIAGRAM

ENCLOSURE

TS (TRANSFER SWITCH)  
VIEW FROM INSIDE FRONT

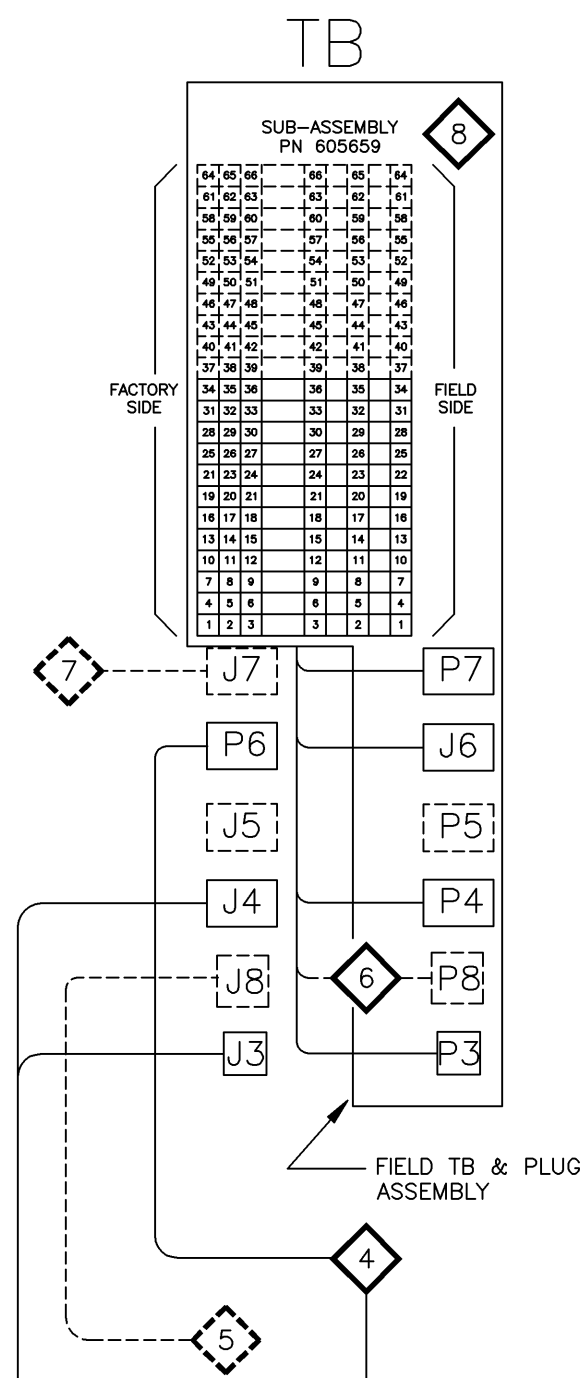
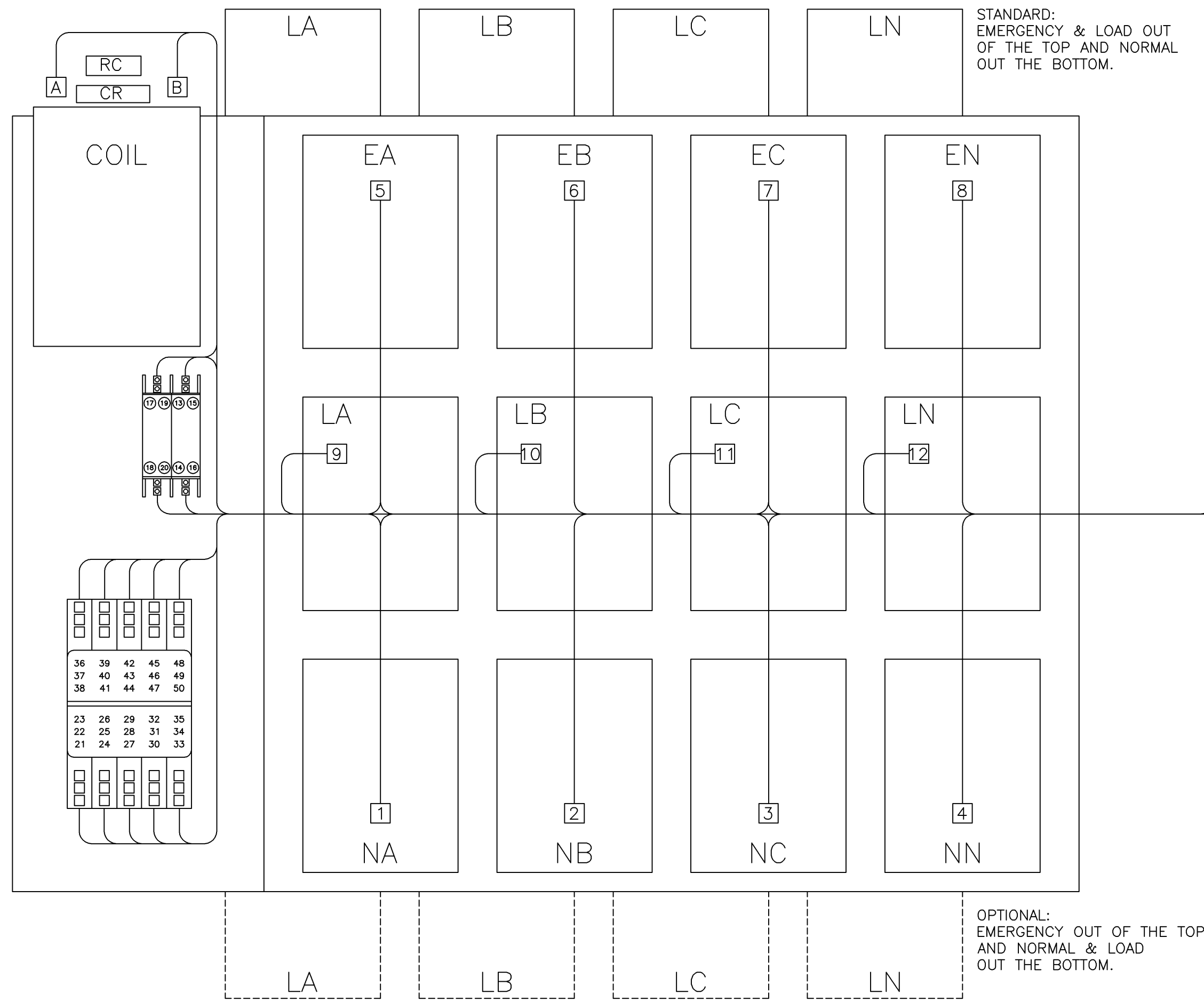

TOP DOOR (INSIDE)

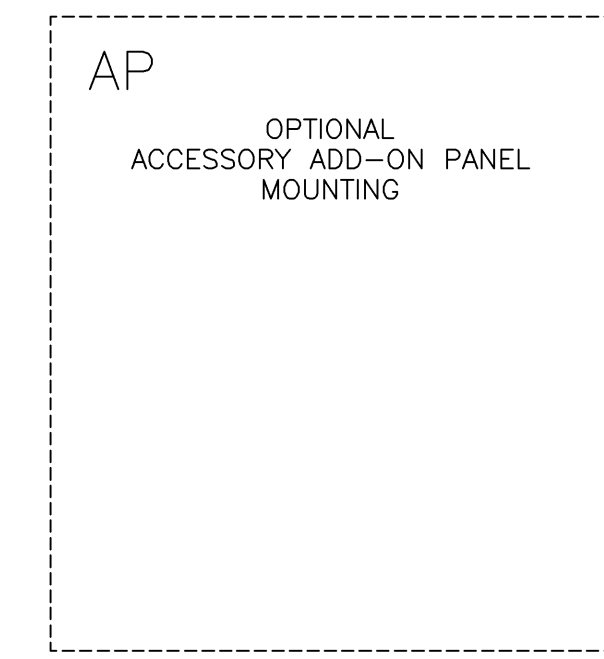
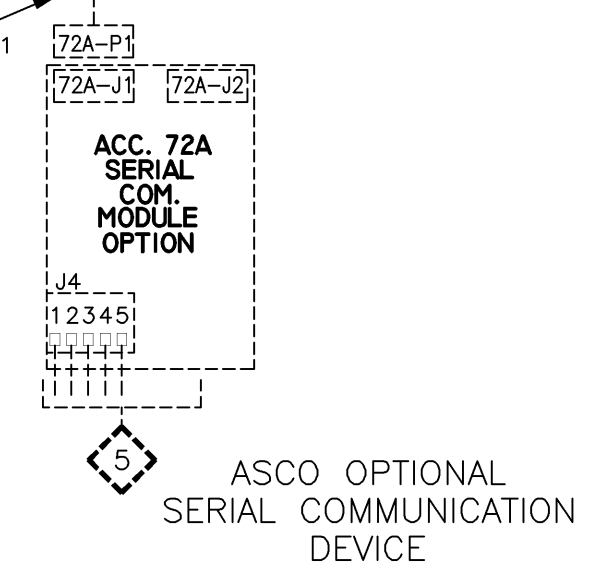
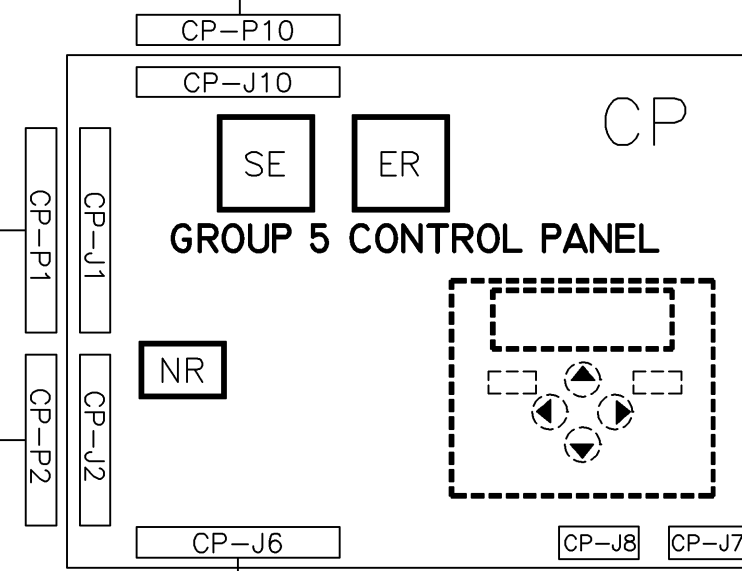
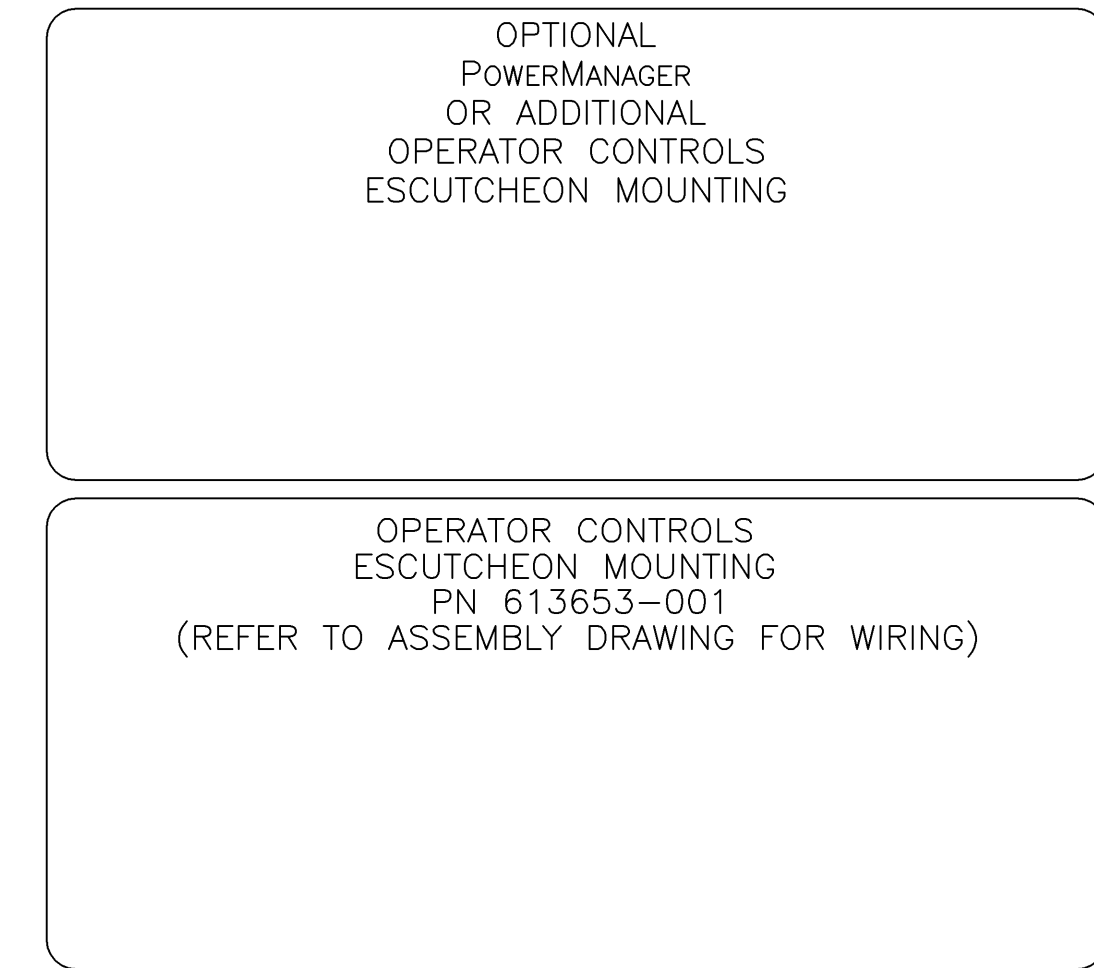

DOOR HINGE

BONDING STRAP  
PN 098323-019

PROJECT NAME:		WIRING DIAGRAM		THIRD ANGLE PROJECTION	
7000 SERIES (J7ATS) GROUP 5 CONTROLS		COMPUTER GENERATED DRAWING		SCALE 1:1 ACAD FILE	
DRAWN BY	BY	DATE	MANUFACTURING TOLERANCES TO BE IN ACCORDANCE WITH ASCO PROCEDURE MP-1-003. FOR PLASTIC PARTS SEE MP-1-055	ASSEM. REF. NO.	SIZE DWG. NO.
CHECKED	BWM	4/05	PROPERTY OF ASCO POWER TECHNOLOGIES. USE PERMITTED FOR OUR WORK ONLY. ALL RIGHTS OF DESIGN OR INVENTION ARE RESERVED.		DS775443
DRAFTING APPROVAL					CHANGE A LETTER
FINAL APPROVAL	SDH	4/05	ASCO POWER TECHNOLOGIES, L.P. FLORHAM PARK, NEW JERSEY 07932 U.S.A.	ASCO	ECN NO. 204462 SHEET 5 OF 6

A	204462	BWM	SDH	5/05
—	204020	BWM	SDH	4/05

CHANGE LETTER	ECN NO.	BY	APP.	DATE

