

Operator's Manual

ASCO® 7000 Series ADTS Automatic Delayed-Transition Transfer Switches E-design 150-400A, F-design 600-800A, G-design 1000-3000A, F-design 3000-4000A,

DANGER

DANGER is used in this manual to warn of high voltages capable of causing shock, burns, or death.

WARNING

WARNING is used in this manual to warn of possible personal injury.

CAUTION

CAUTION is used in this manual to warn of possible equipment damage.

Refer to the outline and wiring drawings provided with your 7000 Series ADTS for all installation and connection details and accessories.

Refer to *Group 5 Controller User's Guide* 381333-126 for ATS status display messages, time delays, pickup & dropout settings, and adjustments.

An experienced licensed electrician must install the ADTS.

Rating Label

Each automatic delayed-transition transfer switch contains a rating label to define the loads and fault circuit withstand / closing ratings. Refer to the label on the transfer switch for specific values.

WARNING

Do not exceed the values on the rating label. Exceeding the rating can cause personal injury or serious equipment damage.

Nameplate

The Transfer Switch nameplate includes data for each specific 7000 Series ADTS. Use the switch only within the limits shown on this nameplate. A typical Catalog Number is shown on the next page with its elements explained.



G design 2000 amp.

TABLE OF CONTENTS

	section-page
INSTALLATION	1-1
Mounting and Line Connections	1-1
Auxiliary Circuits and Harness	1-2
Engine Starting Contacts	1-2
Functional Test	1-2, 1-3, 1-4, 1-5
TESTING & SERVICE	2-1
Transfer Test	2-1
Preventive Maintenance	2-1
Disconnecting the Controller	2-1
Manual Load Transfer	2-2
Trouble-Shooting	2-2
INDEX	back cover

Catalog Number Identification

Typical 7000 Series catalog no. for G–design switched neutral, 3 pole, 2000 amp, 480 V, ADTS in Type 1 enclosure:

design prefix letter	G	7ADTS	B	3	2000	N	5	C
	Neutral	Phase Poles	Amperes		Voltage		Controller	Enclosure
	A – solid B – switched blank – none	2 – single Ø 3 – three Ø	150 260 400 600 800	1000 1200 1600 2000 3000 4000	A 115 B 120 C 208 D 220 E 230 F 240 G 277 H 380	J 400 K 415 L 440 M 460 N 480 P 550 Q 575 R 600	5 – standard 5X – if accessories ordered	C – type 1 F – type 3R G – type 4 L – type 12 M –type 3R secure N –type 4 secure P –type 4X secure Q –type 12 secure blank – open type

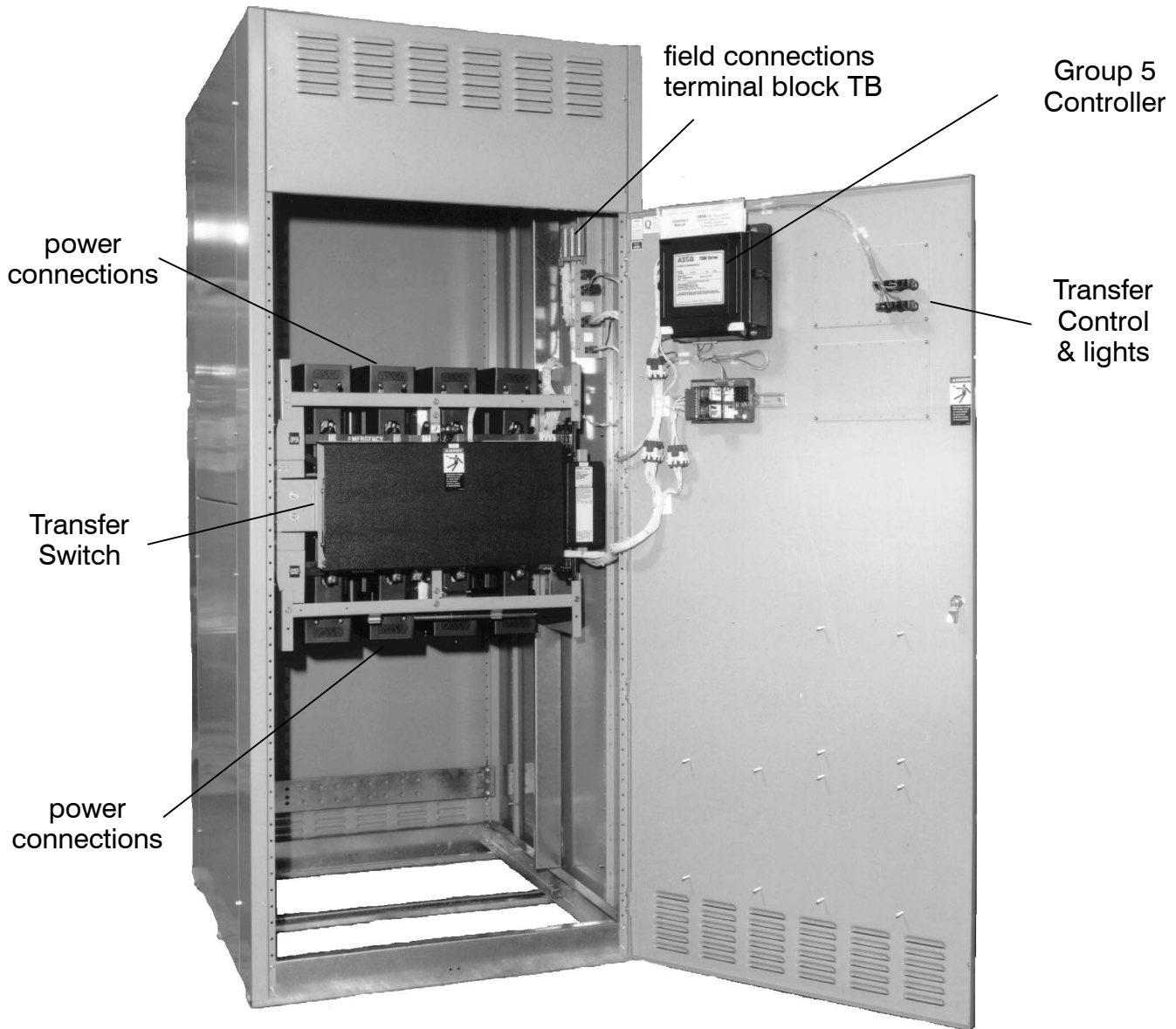

G–design 2000 amp size in typical enclosure with location of customer connections

SECTION 1 INSTALLATION

ASCO Series 7000 Automatic Delayed–Transition Transfer Switches are factory wired and tested. Field installation simply requires mounting and connection of service cables, and auxiliary control circuits (if required).

Remove the Shipping Skid

For large switches, open the front door and remove the four lag screws (2 in front, 2 in rear) securing enclosure to the wood skid.

Supporting Foundation

The supporting foundation for the enclosure must level and straight. Refer to the applicable enclosure outline drawing included with the ADTS for all mounting details including door opening space.

If bottom cable entry is used, the foundation must be prepared so that the conduit stubs are located correctly. Refer to the enclosure outline drawing for specified area and location. Provide cable bending space and clearance to live metal parts. When a concrete floor is poured, use interlocking conduit spacer caps or a wood or metal template to maintain proper conduit alignment.

Mounting

Refer to the outline and mounting diagram provided with the ADTS; it shows all mounting details and instructions.

CAUTION

Protect the switch from construction grit and metal chips to prevent malfunction or shortened life of the automatic switch switch.

Mount the ADTS vertically to a rigid supporting structure. Level all mounting points by using flat washers behind the holes to avoid distortion of the switch.

The controller is mounted on the cabinet door. An add-on DIN rail is provided for some optional accessories and is mounted below controller on the door.

Auxiliary Cable Boxes

For 1000 & 1200 amp. sizes, an auxiliary cable box is required for all (normal, emergency, & load) bottom or top entry. Order ASCO part no. 609027 if required.

CAUTION

On 1000 & 1200 amp. be sure to install auxiliary cable box if both service and load cables are entering through the top or bottom of enclosure.

Line Connections

A *Wiring Diagram* is furnished with the ASCO Series 7000 ADTS (separate from this manual). Refer to this drawing. All wiring must be made in accordance with the National Electrical Code and local codes.

DANGER

De-energize the conductors before making any line or auxiliary circuitry connections. Be sure that Normal and Emergency line connections are in proper phase rotation. Place engine generator starting control in the OFF position. Make sure engine generator is not in operation.

Testing Power Conductors

Do not connect the power conductors to the transfer switch until they are tested. Installing power cables in conduit, cable troughs and ceiling-suspended hangers often requires considerable force. The pulling of cables can damage insulation and stretch or break the conductor's strands. For this reason, after the cables are pulled into position, and before they are connected, they should be tested to verify that they are not defective or have been damaged during installation.

Connecting Power Conductors

After the power cables have been tested, connect them to the appropriate terminal lugs on the transfer switch as shown on the wiring diagram provided with the switch. Make sure the lugs provided are suitable for use with the cables being installed. Standard terminal lugs are solderless screw type and will accept the wire sizes listed on the drawings provided with the switch. Be careful when stripping insulation from the cables; avoid nicking or ringing the conductor. Remove surface oxides from cables by cleaning with a wire brush. When aluminum cable is used, apply joint compound to conductors. Tighten cable lugs to the torque specified on rating label.

Do not run cables in front of or behind the switch. Cables can be bundled on the right side of the switch. Maintain proper electrical clearance between the live metal parts and grounded metal: ½ inch minimum for 150-400 amps, 1 inch minimum over 400 amps.

It is not necessary to remove the barriers from the transfer switches to install the cables. If you do remove them, however, be sure to reinstall the barriers carefully.

Bus Connections

For large switches use grade 5 hardware to connect bus to appropriate terminal plates. Wipe off the bus surfaces before they are joined. If the bus is very dirty, gently clean the surfaces with a non-flammable solvent. Avoid touching the cleaned surfaces.

INSTALLATION *(continued)*

Tighten bolted joints to the torque specified in Table A.

⚠ CAUTION

The reliability of the connection depends on how clean and how tight the joint is.

Table A. Tightening torque values for bolted joints (Grade 5 hardware)

Bolt Diameter in inches	Tightening Torque in foot pounds
1/4	7
5/16	12
3/8	20
1/2	50
5/8	95
3/4	155

Controller Ground

A grounding wire must be connected to the controller's lower left mounting stud. Because the controller is mounted on the enclosure door, a conductive strap must be used between the enclosure and the door. This connection provides proper grounding which does not rely upon the door hinges.

Harnesses

The transfer switch is connected to the left side of the control panel by a plug-in harness (two plugs).

Auxiliary Circuits

Connect auxiliary circuit wires to appropriate terminals on the transfer switch. Note the control features that are furnished on this switch. Make the necessary auxiliary connections by referring to the Wiring Diagram.

Engine Starting Contacts

The engine control contact connections (if used) are located on the transfer switch. Connect signal wires to appropriate terminals as specified in Table B and shown in Figure 1–1.

Table B. Engine start connections

When normal source fails	Terminals on transfer switch
contact closes	TB1 and TB2
contact opens	TB1 and TB3

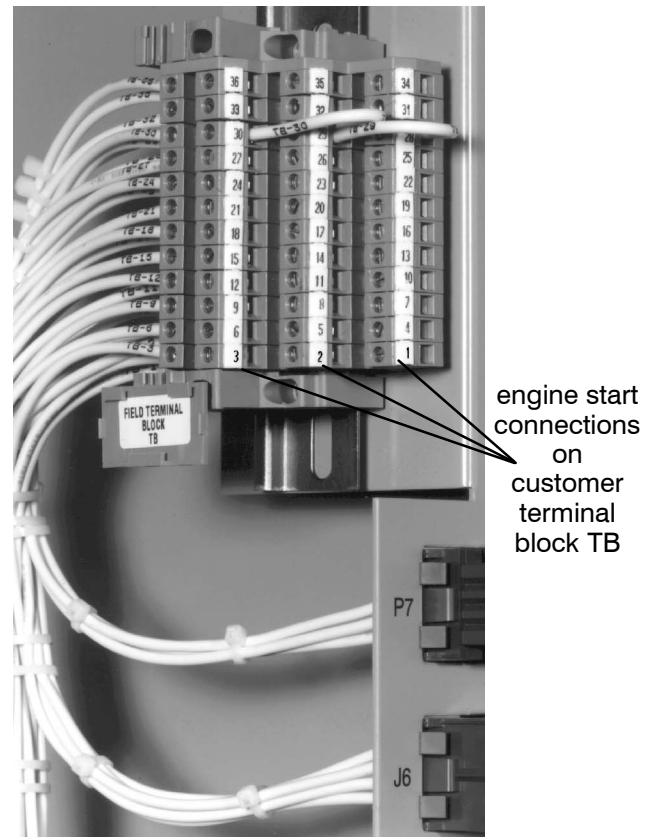

Figure 1-1. Customer terminal block on the top right side of enclosure.

Functional Test

The Functional Test consists of three checks:

- 1 — Manual Operation Test, page 1–3
- 2 — Voltage Checks, page 1–4
- 3 — Electrical Operation, page 1–5

Read all instructions on the Wiring Diagram and labels affixed to the ADTS. Note the control features that are provided and review their operation before proceeding.

Continue to **1 – Manual Operation Test** on next page.

⚠ CAUTION

Do these checks in the order presented to avoid damaging the ATS.

INSTALLATION (continued)

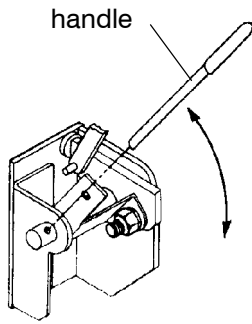

Figure 1-2.
150 – 400 A (3 pole)
E-design switches

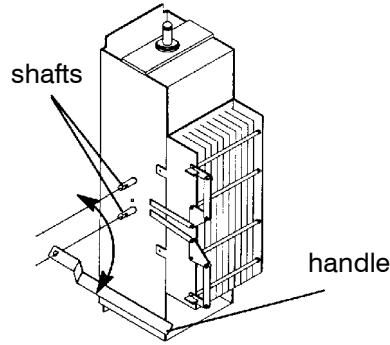

Figure 1-3.
600 & 800 A (& 4 pole 400 A)
F-design switches

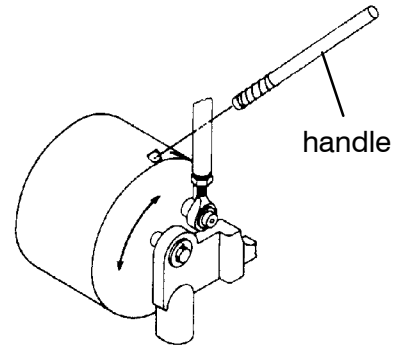

Figure 1-4
3000 & 4000 amp.
F-design transfer switches

1 – Manual Operation

A detachable manual operator handle is provided on the Transfer Switches **for maintenance purposes only**. Manual operation of both CN and CE transfer switches must be checked before they are operated electrically.

⚠ WARNING

Do not manually operate the transfer switches until both power sources are disconnected: open both circuit breakers.

1. Select the appropriate switch amperage size above and follow the directions for installing the handle:

150 through 400 amp. E-design See Figure 1-2.
Insert the manual handle into the hole in the shaft, left side of the operator.

600 and 800 amp. F-design See Figure 1-3.
Attach the manual handle onto the pivot shaft extension, left side of the operator.

1000 through 3000 amp. G-design See Figure 1-5.
Install the hub (with pin) onto the shaft and insert the manual firmly into the side hole in the hub. Push in or pull out hub to engage opposite source contacts.

3000 and 4000 amp. F-design See Figure 1-4.
Insert the manual handle into the hole in the weight.

2. Move the handle as shown to manually operate the Transfer Switch. The switch should operate smoothly without binding. If it does not, check for shipping damage or construction debris. Repeat the manual operation check on the other Transfer Switch.
3. Return the CN Transfer Switch to the *C* (closed) position. Return the CE Transfer Switch to the *O* (open) position. Remove manual operator handle and store it on the Transfer Switch in the place provided.

⚠ WARNING

Verify that the maintenance handle has been removed and stored properly before proceeding!

Now continue to **2 – Voltage Checks** on next page.

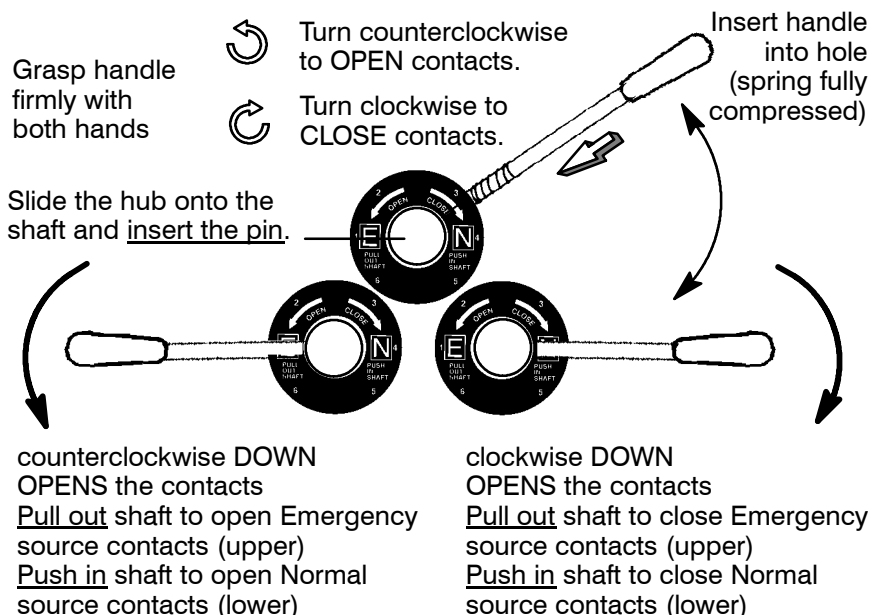
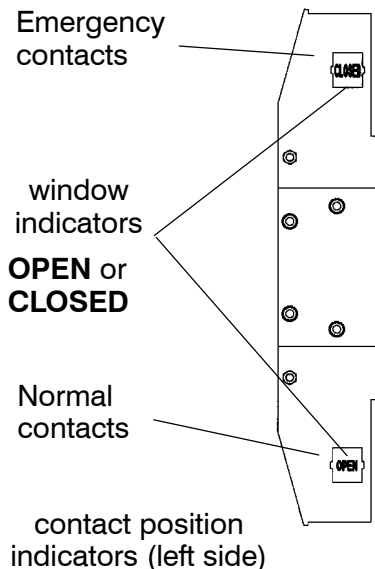

Figure 1-5. 1000 – 3000 amp. G-design transfer switches.

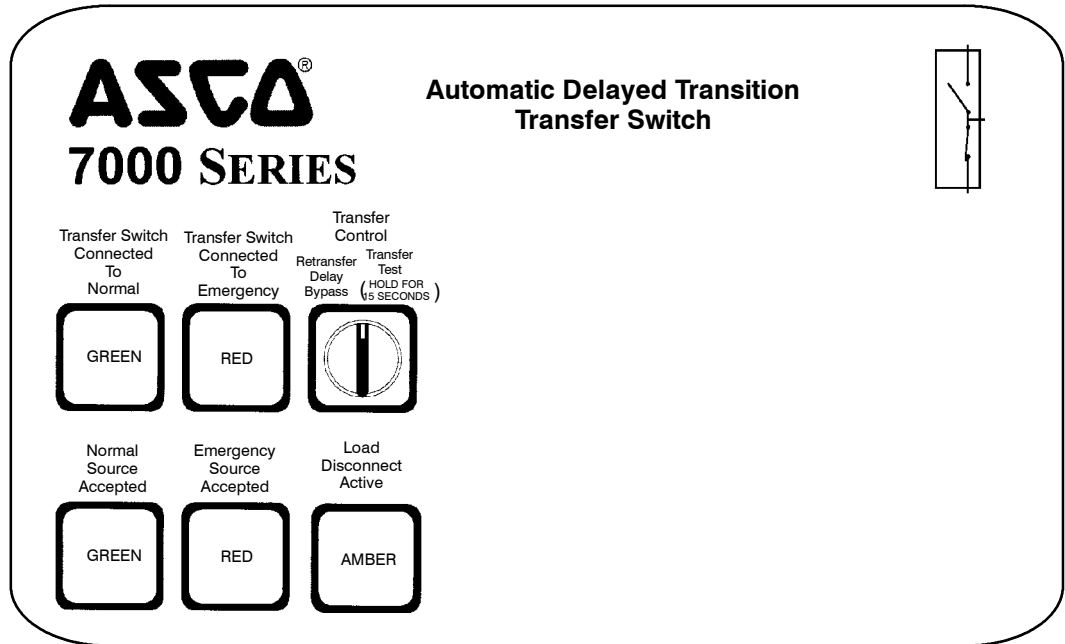

Figure 1-6. Standard controls and indicators.

2 – Voltage Checks

First check nameplate on transfer switch; rated voltage must be the same as normal and emergency line voltages.

⚠ CAUTION

Verify that the feeders have been connected to the proper lugs.

⚠ DANGER

Use extreme caution when using a meter to measure voltages. Do not touch power terminals; shock, burns, or death could result !

Perform steps 1 through 6 at the right. Observe the status lights. See Figure 1–6.

- Black square means light is on.
- White square means light is off.

* If necessary, adjust voltage regulator on the generator according to the manufacturer’s recommendations. The Automatic Transfer Switch will respond only to the rated voltage specified on the Transfer Switch nameplate.

Note

Refer to Section 3 of *Group 5 Controller User’s Guide* 381333–126 for how to display the Status of the ATS and the Voltage and Frequency of each source.

Now continue to **3 – Electrical Operation** on next page.

1	Close the normal source circuit breaker. The <i>Transfer Switch Connected To Normal</i> and the <i>Normal Source Accepted</i> lights should come on.	
2	Use an accurate voltmeter to check phase to phase and phase to neutral voltages present at the transfer switch normal source terminals.	
3	Close the emergency source circuit breaker. (Start generator, if necessary.) The <i>Transfer Switch Connected To Normal</i> & <i>Emergency Source Accepted</i> lights should come on.	
4	Use an accurate voltmeter to check phase to phase and phase to neutral voltages present at the transfer switch emergency source terminals.*	
5	Use a phase rotation meter to check phase rotation of emergency source; it must be the <u>same</u> as the normal source.	
6	Shut down the engine-generator, if applicable. The <i>Emergency Source Accepted</i> light should go off. Then put the starting control selector switch (on the generator set) in the <i>automatic</i> position. Close enclosure door.	

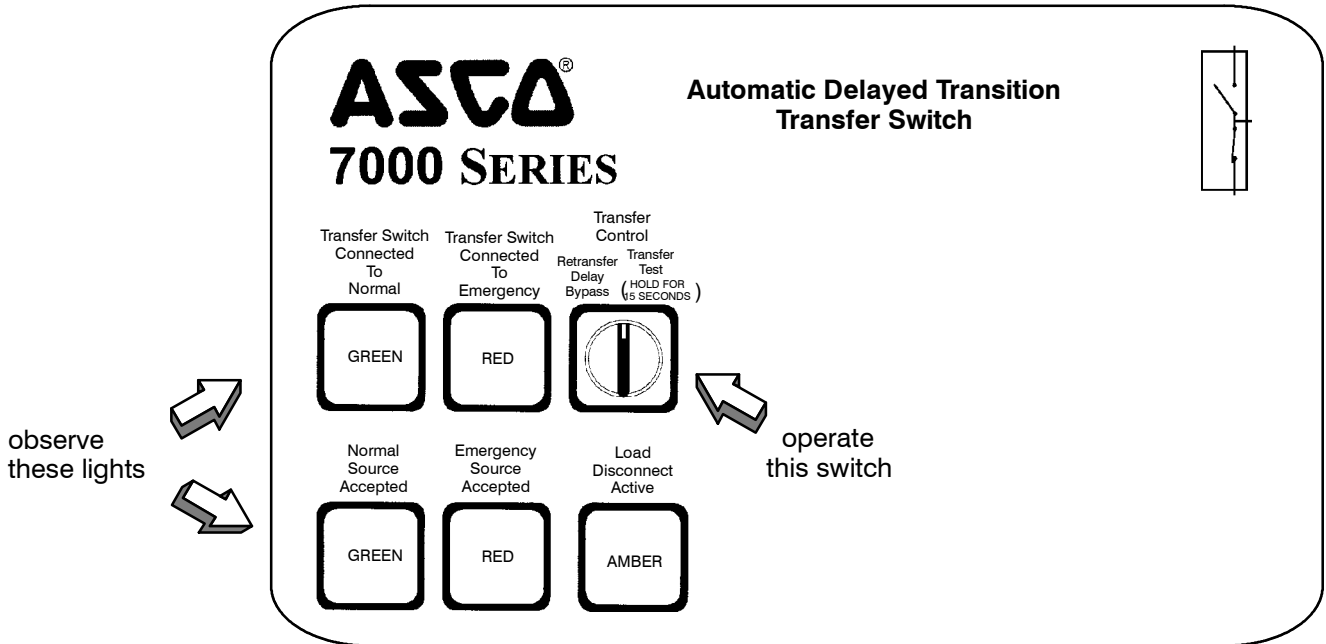

Figure 1-7. Standard controls and indicators.

3 – Electrical Operation

This procedure will check the electrical operation of the Automatic Delayed-Transition Transfer Switch. See Figure 1-7.

⚠
WARNING

Close the enclosure door first.

Transfer Test

Both normal and emergency sources must be available and the emergency source generator (if used) must be capable of being started in this procedure.

Perform steps 1 through 5 at the right. Observe the status lights.

- Black square means light is on.
- White square means light is off.

This completes the Functional Test of the ADTS.

1	Turn and <u>hold</u> Transfer Control switch clockwise to <i>Transfer Test</i> until the engine starts and runs (within 15 sec.). The <i>Emergency Source Accepted</i> light should come on.	
2	Transfer switch CN opens and the <i>Transfer Switch Connected to Normal</i> light should go off and the <i>Load Disconnect Active</i> light should come on. Both CN & CE contacts are now open.	
3	After the delay transition time delay, the CE Transfer switch will operate to the Emergency position. The <i>Transfer Switch Connected To Emergency</i> light should come on and <i>Load Disconnect Active</i> light goes off.	
4	Transfer switch will operate back to Normal position after Feature 3A time delay. For immediate retransfer turn Transfer Control counterclockwise to <i>Retransfer Delay Bypass</i> . The <i>Transfer Switch Connected To Normal</i> light should come on; <i>Transfer Switch Connected to Emergency</i> light should go off.	
5	The engine-generator will stop after the Feature 2E time delay (unloaded running engine cool-down). The <i>Emergency Source Accepted</i> light should go off.	

SECTION 2 TESTING & SERVICE

TRANSFER TEST

Operate the 7000 Series ADTS at least once a month by following the five-step **Electrical Operation Transfer Test** procedure on page 1-5.

PREVENTIVE MAINTENANCE

Reasonable care in preventive maintenance will insure high reliability and long life for the 7000 Series ADTS. An annual preventive maintenance program is recommended.

ASCO Services, Inc. (ASI) is ASCO Power Technologies' national service organization. ASI can be contacted at 1-800-800-2726 for information on preventive maintenance agreements.

Checklist for Yearly Inspection

DANGER

Hazardous voltage capable of causing shock, burns, or death is used in this transfer switch. Deenergize both Normal – Emergency power sources before performing inspections!

- Clean the ADTS enclosure.** Brush and vacuum away any excessive dust accumulation. Remove any moisture with a clean cloth.
- Check the transfer switch contacts.** Remove transfer switch barriers and check the condition of the contacts. Replace contacts when pitted or worn excessively. Reinstall the barriers carefully.
- Maintain transfer switch lubrication.** If switch is subjected to severe dust or abnormal operating conditions, renew factory lubrication on all movements and linkages. Relubricate solenoid operator if TS coil is replaced. Don't use oil; order *lubrication kit 75-100*.
- Check all cable connections & retighten them.**

REPLACEMENT PARTS

Replacement parts are available in kit form. When ordering parts provide the Serial No., Bill of Material No. (BOM), and Catalog No. from the transfer switch nameplate. Contact your local ASCO Power Technologies Sales Office or ASI:

call 1 – 800 – 800 – ASCO (2726)

DISCONNECTING THE CONTROLLER

The harness disconnect plugs are furnished for repair purposes only and should not have to be unplugged. If the control panel must be isolated, follow these steps:

Disconnecting the Plugs

WARNING

Do not unplug the controller until steps 1a or 1b is completed.

1. Observe the position of the transfer switch.
 - a. If the transfer switch is in the *Normal* position, place standby engine starting control in the *off* position. Then open the emergency source circuit breaker.
 - b. If the transfer switch is in the *Emergency* position, open the normal source circuit breaker. Place the engine starting control in the *test* or *run* position.
2. Separate the two quick disconnect plugs by squeezing the latches. Do not pull on the harness wires.

Reconnecting the Plugs

WARNING

Do not reconnect the controller until steps 1 and 2 are completed.

1. Observe the position of the transfer switch.
 - a. If the transfer switch is in the *Normal* position, be sure that the standby engine starting control is still in the *off* position. The emergency source circuit breaker still should be open.
 - b. If the transfer switch is in the *Emergency* position, normal source circuit breaker still should be open.
2. The two harness plugs and sockets are keyed. Carefully align the plugs with the sockets and press straight in until both latches click.
3. Restore the opposite source as follows:
 - a. If the transfer switch is in the *Normal* position, place the standby engine starting control in the *automatic* position. Then close the emergency source circuit breaker.
 - b. If the transfer switch is in the *Emergency* position, close the normal source circuit breaker.

TESTING & SERVICE

(continued)

MANUAL LOAD TRANSFER

This procedure will manually transfer the load if the control panel is disconnected.

WARNING

Do not manually operate the transfer switch until both power sources are disconnected (all conductors deenergized).

1. Deenergize both the normal and emergency source conductors (remove fuses or open circuit breakers).
2. Use manual handle to manually operate transfer switch to the opposite source. First open the closed transfer switch, then close the other transfer switch. Then remove the handle. See *Manual Operation* on page 1–3.
3. If the transfer switch is in the Emergency position manually start the engine generator and then install emergency source fuse or close the circuit breaker.

TROUBLE-SHOOTING

Note any optional accessories that may be furnished on the ADTS and review their operation. Refer to any separate drawings and/or instructions that may be packed with the ADTS.

DANGER

Hazardous voltage capable of causing shock, burns, or death is used in this switch. Do not touch the power or load terminals of the transfer switch!

Table 2-1. Trouble-Shooting Checks.

PROBLEM	CHECK IN NUMERICAL SEQUENCE		
	1 OPERATION	2 GEN-SET	3 VOLTAGE
Engine-generator set does not start when the Transfer Control switch is turned and <u>held</u> in <i>Transfer Test</i> position or when normal source fails.	Hold <i>Transfer Test</i> switch 15 seconds or the outage must be long enough to allow for Feature 1C time delay plus engine cranking and starting.	Starting control must be in the automatic position. Batteries must be charged and connected. Check wiring to engine starting contacts.	–
Transfer switch does not transfer the load to the emergency source after the engine-generator set starts.	Wait for Feature 2B time delay to time out.	Generator output circuit breaker must be closed. Generator frequency must be at least 95% of nominal (57 Hz for a 60 Hz system.) *	Voltmeter should read at least 90% of nominal phase to phase voltage between terminals EA and EC (or EL1 and EL2 for 2 pole switches)*
Transfer switch does not transfer the load to normal source when normal returns or when the Transfer Control switch is released.	Wait for Feature 3A time delay to time out.	–	Voltmeter should read at least 90% of nominal phase to phase voltage between terminals NB and NC, NC and NA, and NA and NB (or NL1 and NL2 for 2 pole switches).
Gen. does not stop after load retransfer to normal source.	Wait for Feature 2E time delay to time out.	Starting control must be in the automatic position.	–

* These are factory settings. Refer to **Controller User's Guide**.

If the problem is isolated to circuits on the controller or the transfer switch, call your local ASCO Power Technologies sales office or ASI at 1–800–800–2726. Furnish the Serial No. and Catalog No. from the transfer switch nameplate.

INDEX

A

auxiliary cable box, 1-1
auxiliary circuits, 1-2

B

barriers, 1-1

C

cable
 lugs, 1-2
 preparation, 1-2
catalog number, cover
cleaning, 2-1
connections
 line, 1-1
controller, 1-1
 disconnecting, 2-1
 see *Controller User's Guide*

E

electrical operation, 1-5
Emergency Source Accepted light, 1-5

F

frequency, generator, 2-2
functional test, 1-2, 1-3, 1-4, 1-5

H

harness, 1-2
 disconnect plugs, 2-1

I

inspection, 3-1
installation, 1-1

L

labels,
 engine start contacts, 1-2
 rating, cover
lights, 1-4, 1-5
Load Disconnect Active light, 1-5
lubrication, 2-1

M

maintenance, preventive, 3-1
manual load transfer, 3-2
 warning, 3-2
manual operation, 1-3
 illustration of, 1-3
 warning, 1-3

N

nameplate, cover
Normal Source Accepted light, 1-5

O

operation
 electrical, 1-5
 manual, 1-3
 illustration of, 1-3
 warning, 1-3
 sequence of, 2-1
optional accessories
 see *Controller User's Guide*

P

parts, 2-1
phase rotation check, 1-4
problem, 2-2

R

rating label, cover
replacement parts, 2-1

S

settings
 see *Controller User's Guide*

T

test, functional, 1-2, 1-3, 1-4, 1-5
time delays, 2-1
 see *Controller User's Guide*
Transfer Control selector switch
 Retransfer Delay Bypass, 1-5
 Transfer Test, 1-5
*Transfer Switch Connected to
 Emergency* light, 1-5
*Transfer Switch Connected to Normal
 light*, 1-4, 1-5
transfer test, 1-5
transfer to emergency, 1-5
transfer to normal, 1-5, 2-1
trouble-shooting, 2-2

V

voltage checks, 1-4
voltage, pickup and dropout settings
 see *Controller User's Guide*