

# Operator's Manual

# ASCO® 7000 Series ATB Automatic Transfer & Bypass-Isolation Switches G design 1000 through 3000 amp.

## DANGER

**DANGER** is used in this manual to warn of high voltages capable of causing shock, burns, or death.

## WARNING

**WARNING** is used in this manual to warn of possible personal injury.

## CAUTION

**CAUTION** is used in this manual to warn of possible equipment damage.



1000–2000 amp. sizes

**Note:** Refer to the outline and wiring drawings provided with your 7000 Series ATB for all installation and connection details and accessories.

**Note:** Refer to *Group 5 Controller User's Guide* 381333–126 for ATS status display messages, time delays, pickup & dropout settings, and adjustments.

An experienced licensed electrician must install the ATB.

## Rating Label

Each 7000 Series ATB contains a rating label to define the loads and fault circuit withstand/closing ratings. Refer to the label on the Transfer Switch for specific values.

## WARNING

**Do not exceed the values on the rating label. Exceeding the rating can cause personal injury or serious equipment damage.**

## TABLE OF CONTENTS

	section-page
INSTALLATION .....	1-1
Mounting .....	1-1
Power Connections .....	1-2
Engine Starting & Auxiliary Circuits .....	1-2
Functional Test .....	1-3, 1-4
TESTING & SERVICE .....	2-1
Transfer Test .....	2-1
Preventive Maintenance .....	2-1
Disconnecting the Controller .....	2-1
Manual Load Transfer .....	2-2
Trouble-Shooting .....	2-2
BYPASSING & ISOLATING .....	3-1
Bypassing the ATS .....	3-1
Isolating the ATS .....	3-2
Return to Service .....	3-3, 3-4
INDEX .....	back cover

## Nameplate

The Transfer Switch nameplate includes data for each specific 7000 Series ATB. Use the switch only within the limits shown on this nameplate. A typical Catalog Number is shown below with its elements explained:

Neutral	Phase Poles	Amperes
A – solid	2 – single Ø	1000
B – switching	3 – three Ø	1200
C – overlapping		1600
blank – none		2000
		3000

## Catalog Number Identification

A typical Catalog Number is shown below with its elements explained. The example is for a G–design 7000 Series ATB with overlapping neutral, 3 pole, 1600 amp., 480 V, in Type 1 enclosure:

Voltage	Controller	Enclosure
C 208	5 – standard	C – type 1
D 220	5X – if accessories ordered	F – type 3R
E 230		blank – open type
F 240		
H 380		
J 400		
K 415		

## SECTION 1 INSTALLATION

The ASCO 7000 Series Automatic Transfer & Bypass–Isolation Switch (ATB) consists of an upper bypass–isolation switch, a lower transfer switch, a monitoring and transfer controller, and door–mounted controls. The ATB is factory wired and tested. Installation requires removal of the shipping skid then securing the enclosure to the supporting foundation.

### Remove the Shipping Skid

Open the front lower door and remove the two front lag screws securing the enclosure to the wood skid. Next remove the rear lower panel and remove the two rear lag screws securing the enclosure to the wood skid.

### Supporting Foundation and Mounting

The supporting foundation for the enclosure must be level and straight. Allow at least 35 inches in front of the enclosure for draw out of the Transfer Switch. Refer to the enclosure outline drawing included with the ATB for all mounting details including door opening space.

If bottom cable entry is used, the foundation must be prepared so that the conduit stubs are located correctly. Refer to the appropriate enclosure outline drawing for specified cable entrance area and location. Provide cable bending space and clearance to live metal parts. When a concrete floor is poured, use interlocking conduit spacer caps or a wood or metal template to maintain proper conduit alignment.

Refer to the enclosure outline drawing furnished with this switch and mount the 7000 Series ATB according to the details and instructions shown on the drawing.

### Remove three Shipping Angles from the Transfer Switch

Open the lower front door. The Transfer Switch carriage is secured to the frame for shipment. Remove the three shipping angles (1 upper left, 1 upper right, 1 lower right).

### CAUTION

To prevent serious damage, remove 3 shipping angles from the transfer switch carriage. Do not turn the Isolation Handle until they are removed!

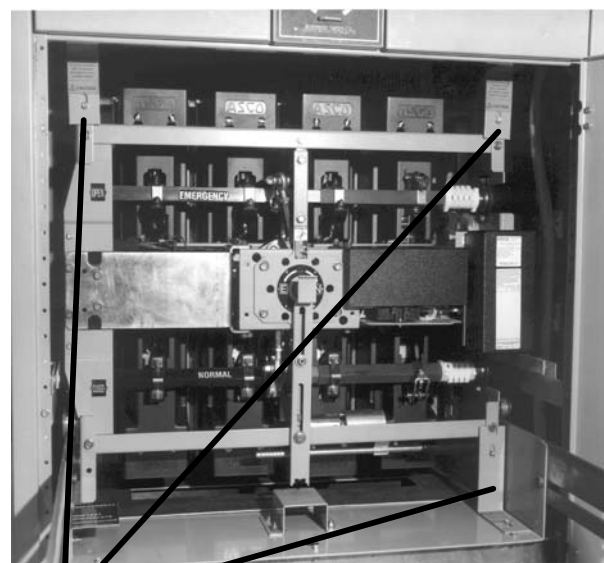

remove 3 shipping L–angles from transfer switch

Figure 1-1. Remove three shipping L–angles.

## INSTALLATION (continued)

### DANGER

**De-energize the conductors before making any line or auxiliary circuitry connections. Be sure that Normal and Emergency line connections are in proper phase rotation. Place engine generator starting control in the OFF position. Make sure engine generator is not in operation.**

### Testing Power Conductors

Do not connect the power conductors to the ATB until they are tested. Installing power cables in conduit, cable troughs, and ceiling-suspended hangers often requires considerable force. The pulling of cables can damage insulation and stretch or break the conductor's strands. For this reason, after the cables are pulled into position, and before they are connected they should be tested to verify that they are not defective or have been damaged during installation.

### CAUTION

**Protect the switch from construction grit and metal chips to prevent malfunction or shortened life for the ATB switch.**

### Connecting Power Conductors

A *Wiring Diagram* is furnished with the ATB. All wiring must be made in accordance with the local codes. After the power cables have been tested, connect them to the appropriate terminal lugs on the Bypass Switch as shown on the wiring diagram provided with this ATB. Make sure that the lugs provided are suitable for use with the cables being installed. Standard terminal lugs are solderless screw type and will accept the wire sizes listed on the drawings provided with the ATB. Be careful when stripping insulation from conductors; avoid nicking or ringing the conductor. Remove surface oxides from conductors by cleaning with a wire brush. Follow conductor manufacturer's instructions when aluminum conductor is used. Apply joint compound to conductor, then carefully wipe away excess compound. Tighten the cable lugs to the torque specified on the rating label.

### CAUTION

**Be sure that the Normal and Emergency power connections are in proper phase rotation.**

### Bus Connections

If bus connection is used, use SAE grade 5 hardware to connect bus to appropriate terminal plates on bypass switching device. Wipe off bus surfaces before they are joined. If bus is dirty, gently clean surfaces with a non-flammable solvent. Avoid touching cleaned surfaces.

### CAUTION

**Do not breathe cleaning solvent vapors.**

Use SAE grade 5 hardware and tighten the bolted joints to the torque specified in Table 2-1.

### CAUTION

**The reliability of the connection depends on how clean and how tight the joint is.**

Table 2-1. Tightening torque values for bolted joints.

Bolt Diameter (Grade 5 hardware) in inches	Recommended Tightening Torque in foot pounds
5/16	12
3/8	20
1/2	50
5/8	95

### Harnesses

All internal connections are made at the factory. The bypass switch, transfer switch, and control panel are joined together by an interconnecting wire harness. The disconnect plugs are already engaged on enclosed switches. For opentype switches, the plugs must be engaged after installation is completed. Align harness plugs with sockets in the control and push them together until they are secure.

### Engine Starting Contacts and Auxiliary Circuits

The engine control contact signal connections and auxiliary circuits are located on terminal block TB as shown on the *Wiring Diagram* provided with the ATB. Connect the signal wires to the appropriate terminals.

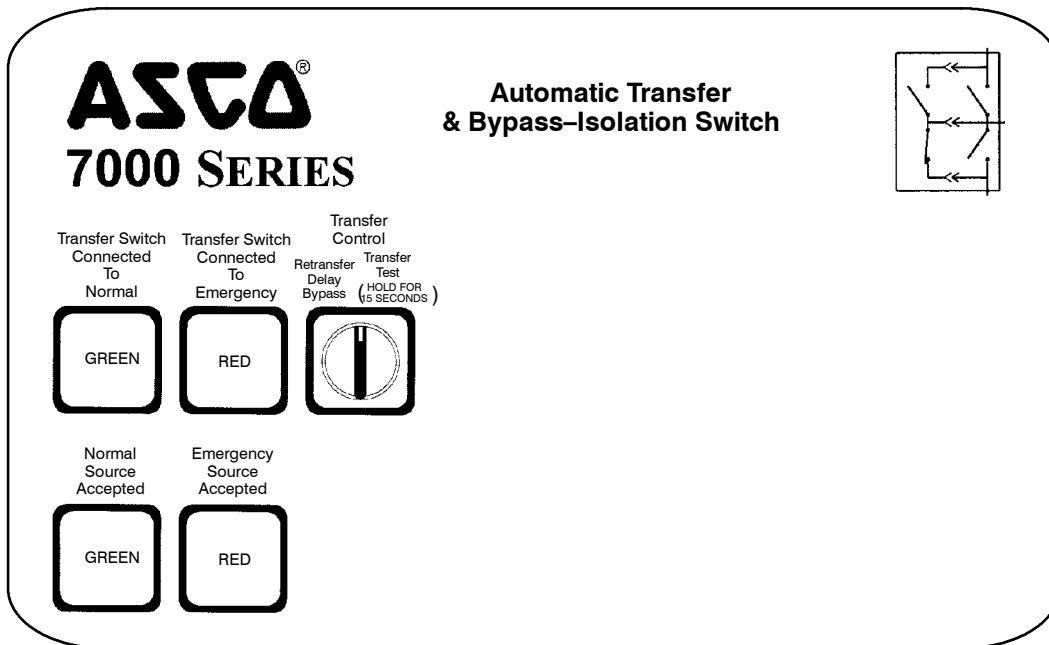

Figure 1-2. Standard controls and indicators.

### Functional Test

Read all instructions on the *Wiring Diagrams* and labels affixed to the ATB. Note the control features that are provided and review their operation before proceeding.

After installing the ATB check the following:

- Bypass Handle should be in the *NORMAL* position.
- Isolation Handle should be in the *CONN* position.
- TS transfer switch Normal contacts should be *CLOSED* (Emergency contacts should be *OPEN*)

If handles are not in correct positions, follow instructions for Bypassing and Isolating the automatic transfer switch in **Section 3**. **Do not force the handles.** Electrical interlocks prevent a wrong sequence of operation.

#### 1 – Voltage Checks

First check nameplate on transfer switch; rated voltage must be the same as normal and emergency line voltages.

**⚠ DANGER**

**Use extreme caution when using a meter to measure voltages. Do not touch power terminals; shock, burns, or death could result !**

Perform steps 1–6 at the right. Observe the status lights. See Figure 1–2.

- Black square means light is on.
- White square means light is off.

\* If necessary, adjust voltage regulator on generator per the manufacturer’s recommendations. The ATB will respond only to rated voltage specified on the nameplate.

Now continue to **2 – Electrical Operation** on next page.

1	Close the normal source circuit breaker. The <i>Transfer Switch Connected To Normal</i> and the <i>Normal Source Accepted</i> lights should come on.	
2	Use an accurate voltmeter to check phase to phase and phase to neutral voltages present at the transfer switch normal source terminals.	
3	Close the emergency source circuit breaker. (Start generator, if necessary.) The <i>Transfer Switch Connected To Normal &amp; Emergency Source Accepted</i> lights should come on.	
4	Use an accurate voltmeter to check phase to phase and phase to neutral voltages present at the transfer switch emergency source terminals.*	
5	Use a phase rotation meter to check phase rotation of emergency source; it must be the <u>same</u> as the normal source.	
6	Shut down the engine-generator, if applicable. The <i>Emergency Source Accepted</i> light should go off. Then put the starting control selector switch (on the generator set) in the <i>automatic</i> position. Close enclosure door.	

# INSTALLATION (continued)

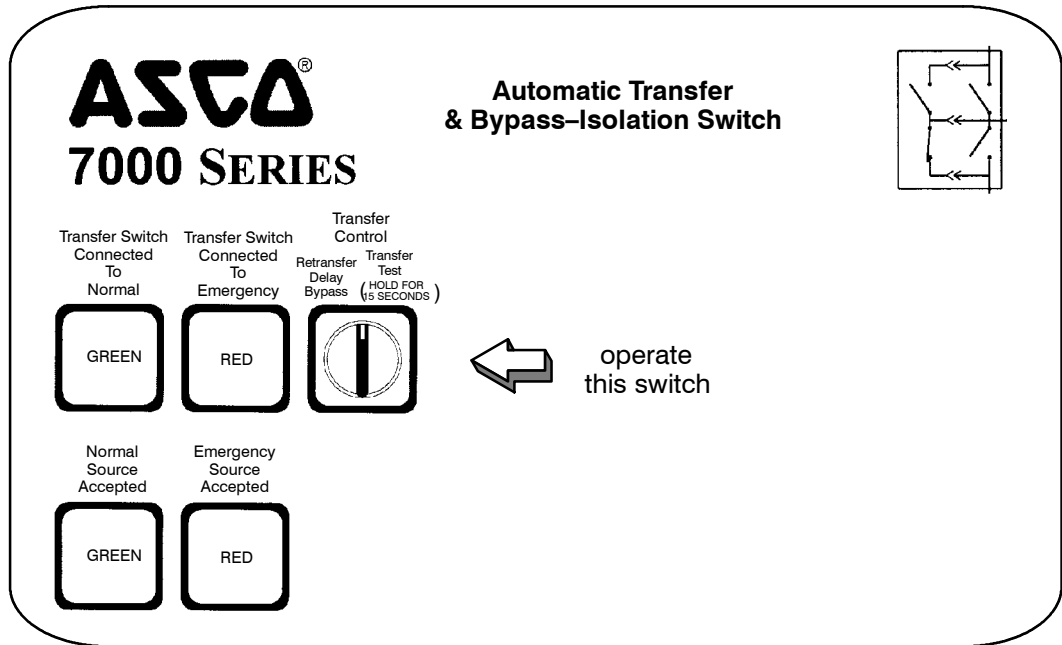

Figure 1-3. Standard controls and indicators.

## 2 – Electrical Operation

This procedure checks electrical operation of the ATS.

**⚠ WARNING**

**Be sure to close the enclosure door before proceeding to prevent personal injury in case of electrical system fault.**

### Transfer Test

The ATS should still be bypassed. Both normal and emergency sources must be available and the emergency source generator (if used) must be capable of being started; put engine starting control in *automatic* position. The *Transfer Switch Connected to Normal* light and the *Normal Source Accepted* light should be on.

1. Turn the **Isolation Handle** counterclockwise to the *TEST* position.  
**NOTE:** The engine generator may be signalled to start while turning the Isolation Handle. If emergency source is available, the ATS may operate to the emergency position. If it does, operate **Retransfer Delay Bypass** switch.
2. Perform steps 1–5 at right. Observe the status lights.  
 Black square means light is on.  
 White square means light is off.
3. Turn the **Isolation Handle** clockwise to the *CONN* (connected) position.
4. Push in the **Bypass Handle** and turn it counterclockwise to the *OPEN* position.

This completes the Functional Test of the ATB.

1	The <i>Transfer Switch Connected to Normal</i> and <i>Normal Source Accepted</i> lights should be on.	
2	Turn and <u>hold</u> <b>Transfer Control</b> switch clockwise to <i>Transfer Test</i> until the engine starts and runs (within 15 sec.). The <i>Emergency Source Accepted</i> light should come on.	
3	Transfer switch will operate to the Emergency position after Feature 2B time delay. The <i>Transfer Switch Connected To Emergency</i> light should come on and <i>Load Connected To Normal</i> light goes off.	
4	Transfer switch will operate back to Normal position after Feature 3A time delay. For immediate retransfer turn <b>Transfer Control</b> counterclockwise to <i>Retransfer Delay Bypass</i> . The <i>Transfer Switch Connected To Normal</i> light should come on; <i>Transfer Switch Connected to Emergency</i> light should go off.	
5	The engine-generator will stop after the Feature 2E time delay (unloaded running engine cool-down). The <i>Emergency Source Accepted</i> light should go off.	

## SECTION 2 TESTING & SERVICE

### TRANSFER TEST

Test the Automatic Transfer Switch portion of the 7000 Series ATB at least once a month. This procedure checks the electrical operation of the Transfer Switch and Controller. Put the engine-generator starting control (at the engine-generator set) in automatic mode.

In the following test the generator will start, the load will be transferred to the Emergency source, then back to the Normal source. An interruption to the load will occur, unless the the Transfer Switch contacts are bypassed before the test. See pages 3-1 and 3-2 for bypassing & isolating instructions if no interruption of load is required.

#### **WARNING**

**Be sure to close the enclosure door before proceeding to prevent personal injury in case of electrical system fault.**

Perform the five-step **Electrical Operation – Transfer Test** procedure on page 1-4.

### PREVENTIVE MAINTENANCE

Reasonable care in preventive maintenance will insure high reliability and long life for the 7000 Series ATB. An annual preventive maintenance program is recommended.

ASCO Services, Inc. (ASI) is ASCO Power Technologies' national service organization. ASI can be contacted at 1-800-800-2726 for information on preventive maintenance agreements.

### Checklist for Yearly Inspection

#### **DANGER**

**Hazardous voltage capable of causing shock, burns, or death is used in this switch. Deenergize both Normal – Emergency power sources before performing inspections!**

- Clean the ATB enclosure.** Brush and vacuum away any excessive dust accumulation. Remove any moisture with a clean cloth.
- Check the transfer switch contacts.** Remove transfer switch barriers and check the condition of the contacts. Replace contacts when pitted or worn excessively. Reinstall the barriers carefully.
- Maintain transfer switch lubrication.** If switch is subjected to severe dust or abnormal operating conditions, renew factory lubrication on all movements and linkages. Relubricate solenoid operator if TS coil is replaced. Don't use oil; order *lubrication kit 75-100*.
- Check all cable connections & retighten them.**

### REPLACEMENT PARTS

Replacement parts are available in kit form. When ordering parts provide the Serial No., Bill of Material No. (BOM), and Catalog No. from the transfer switch nameplate. Contact your local ASCO Power Technologies Sales Office or ASI:

#### **In the United States**

**call 1 – 800 – 800 – ASCO ( 2726 )**

#### **In Canada**

**call 1 – 888 – 234 – ASCO ( 2726 )**

### DISCONNECTING THE CONTROLLER

The harness disconnect plugs are furnished for repair purposes only and should not have to be unplugged. If the controller must be isolated, follow these steps:

#### **DANGER**

**Bypass-Isolation Switch is energized! Do not touch isolation contact fingers; shock, burns, or death could result!**

#### **Disconnecting the Plugs**

1. Bypass and Isolate the Automatic Transfer Switch.
2. Open the upper enclosure door.
3. Separate the two quick disconnect plugs by squeezing the latches. Do not pull on the harness wires.

#### **Reconnecting the Plugs**

1. The ATS should be still bypassed and isolated.
2. The two harness plugs and sockets are keyed. Carefully align the plugs with the sockets and press straight in until the latches click.
3. Close the enclosure doors.
4. Follow *Return to Service* instructions on page 3-3.

# TESTING & SERVICE *(continued)*

## TROUBLE-SHOOTING

Note any optional accessories that may be furnished on the ATB and review their operation. Refer to any separate drawings and/or instructions that may be packed with the ATB.

**⚠ DANGER**

**Hazardous voltage capable of causing shock, burns, or death is used in this switch. Do not touch the power or load terminals of the transfer switch!**

Table 2-1. Trouble-Shooting Checks.

PROBLEM	CHECK IN NUMERICAL SEQUENCE		
	1 OPERATION	2 GEN-SET	3 VOLTAGE
Engine-generator set does not start when the <b>Transfer Control</b> switch is turned and held in <b>Transfer Test</b> position or when normal source fails.	Hold <i>Transfer Test</i> switch 15 seconds or the outage must be long enough to allow for Feature 1C time delay plus engine cranking and starting.	Starting control must be in the automatic position. Batteries must be charged and connected. Check wiring to engine starting contacts.	-
Transfer switch does not transfer the load to the emergency source after the engine-generator set starts.	Wait for Feature 2B time delay to time out.	Generator output circuit breaker must be closed. Generator frequency must be at least 95% of nominal (57 Hz for a 60 Hz system.) *	Voltmeter should read at least 90% of nominal phase to phase voltage between transfer switch terminals EA & EC (or EL1 & EL2 for 2 pole)*
Transfer switch does not transfer the load to normal source when normal returns or when the <b>Transfer Control</b> switch is released.	Wait for Feature 3A time delay to time out.	-	Voltmeter should read at least 90% of nominal phase to phase voltage between transfer switch terminals NB & NC, NC & NA, & NA & NB (or NL1 & NL2 for 2 pole).
Engine-generator-set does not stop after load retransfer to the normal source.	Wait for Feature 2E time delay to time out.	Starting control must be in the automatic position.	-

\* These are factory settings.

Refer to **Controller's User's Guide**.

If the problem is isolated to circuits on the controller or the transfer switch, call your local ASCO Power Technologies sales office or ASI: in the United States, call 1-800-800-2726 or in Canada call 1-888-234-2726. Furnish the Serial No., Catalog No., and Bill of Material (BOM) No. from the transfer switch nameplate.

## MANUAL LOAD TRANSFER

This procedure manually transfers load to other source if the Transfer Switch or Controller are out of service.

**⚠ WARNING**

**Close enclosure doors to prevent personal injury in case of electrical system fault.**

1. Be sure that the Bypass Handle is *CLOSED* on either Emergency or Normal (see page 3-1).
2. Be sure that the Isolation Handle is in the *TEST* or *ISOLATE* position (see page 3-2).
3. Turn the Bypass Handle counterclockwise to *OPEN* the Bypass Switch. Then Bypass to the other source (see page 3-1).

## MAINTENANCE HANDLE

**⚠ DANGER**

**Bypass and isolate Transfer Switch before using the maintenance handle! See pages 3-1 & 3-2. Remove the handle after using it and store it on the frame.**

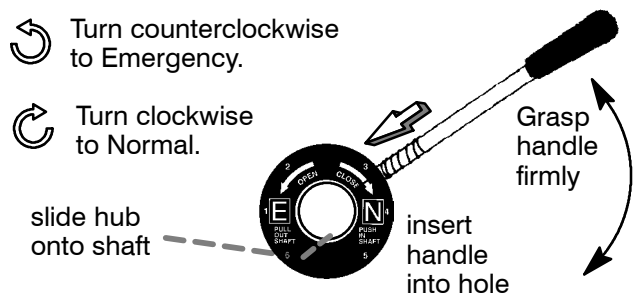

## SECTION 3 BYPASSING & ISOLATING

### BYPASSING THE ATS\*

This procedure explains how to Bypass the closed automatic transfer switch contacts. Bypassing is required before the ATS can be tested or isolated. The Bypass Handle must be in the *OPEN* position (green indicator) and the Isolation Handle must be in the *CLOSED* position (window). See Figures 3-1, 3-2, and 3-3.

**⚠ CAUTION**

**You can only bypass to the same source that the ATS is connected. Solenoid interlock prevents incorrect operation.**

1. Observe which *Transfer Switch Connected To* light is on (*Normal* or *Emergency*) on the door. This is the position of the automatic transfer switch.
2. Bypass to the same source as connected to transfer switch as follows (select Normal or Emergency).

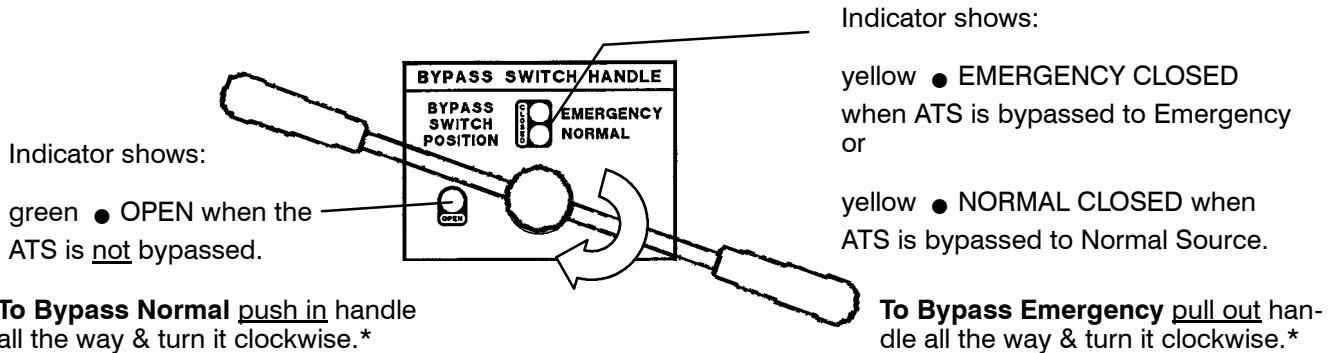

Figure 3-1. Bypass Handle and position indicators.

#### To Bypass Normal Source\*

(Load connected to Normal Source)

The *Transfer Switch Connected To Normal* light is on and *Transfer Switch Connected To Emergency* light is off.

Push in\* the Bypass Handle all the way, then turn it clockwise until *Bypass Switch Position* shows CLOSED on NORMAL (yellow indicator). The red light *Unit Not In Automatic* will flash.

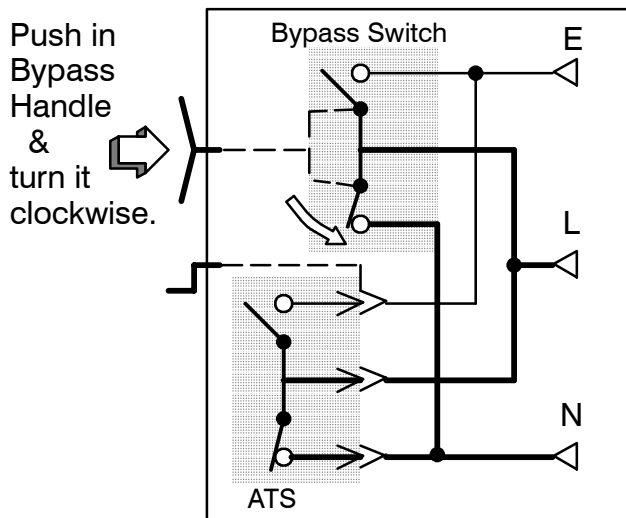

Figure 3-2. Bypass to Normal.

#### To Bypass Emergency Source\*

(Load connected to Emergency Source)

The *Transfer Switch Connected To Emergency* light is on and *Transfer Switch Connected To Normal* light is off.

Pull out\* the Bypass Handle all the way, then turn it clockwise until *Bypass Switch Position* shows CLOSED on EMERGENCY (yellow indicator). The red light *Unit Not In Automatic* will flash.

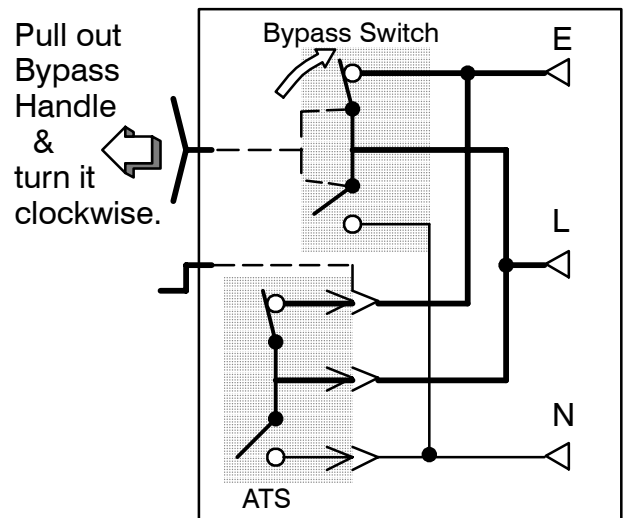

Figure 3-3. Bypass to Emergency.

The automatic transfer switch can now be put in the *TEST* or *OPEN* position. See **ISOLATING** on page 3-2.

\* **NOTE:** When Accessory 66A (reversed Normal & Emergency connections) is specified, the handle push-pull operation is reversed. Follow instructions on the door.

# BYPASSING & ISOLATING

(continued)

## ISOLATING THE ATS

Isolating is required before any service work can be performed on the automatic transfer switch (ATS). Refer to Figures 3-4, 3-5, 3-6, and 3-7.

1. Bypass the closed automatic transfer switch contacts. See **BYPASSING** on page 3-1.

**⚠ CAUTION**

**Align position indicator. Do not leave the handle in an intermediate position.**

2. Turn the Isolation Handle counterclockwise (approx. 16 turns) until window shows *TEST*. The ATS can be tested now without load interruption (see page 2-1).

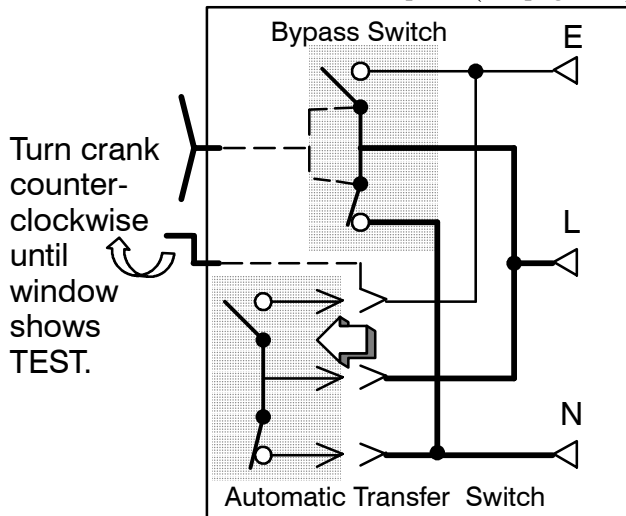

Figure 3-4. *CONNECTED* to *TEST* position.

3. Continue turning Isolation Handle counterclockwise (approx. 7 turns) until the window shows *ISOLATE*.

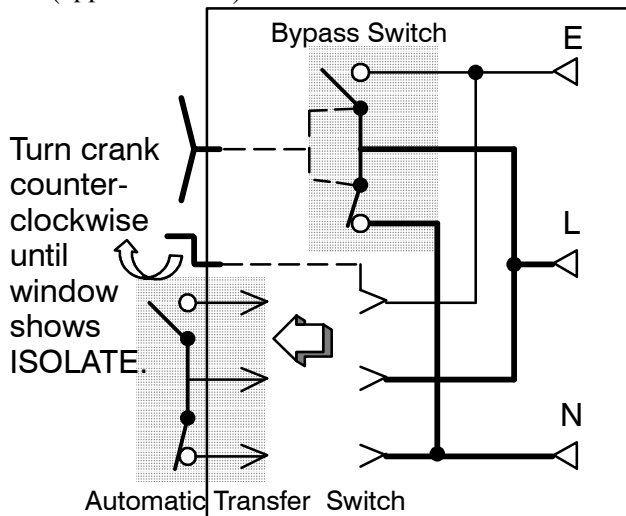
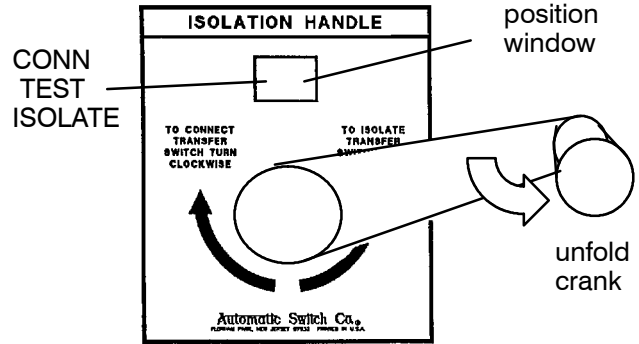

Figure 3-5. *TEST* to *ISOLATE* position.

4. Open the lower enclosure door. Pull out the side rail carriage then roll out the transfer switch. It can be safely inspected in this position. The transfer switch can also be removed for easier maintenance operations.



counterclockwise – draws out the transfer switch

Figure 3-6. Isolation Handle.

**NOTE:** In the *TEST* position the transfer switching device solenoid operator circuit is energized through secondary disconnects.

**⚠ DANGER**

**Hazardous voltage capable of causing electrical shock, burns, or death; do not touch any control circuit terminals.**

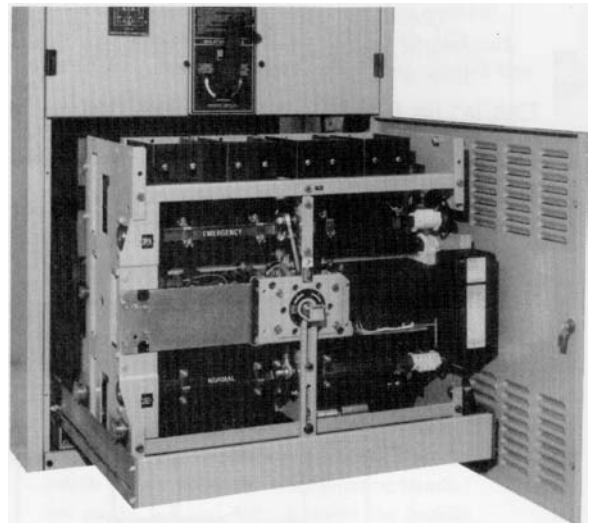

Figure 3-7. Transfer switch isolated and pulled out for inspection.

See page 2-2 for maintenance handle use. A lifting yoke kit 607064 is available to facilitate lifting by using an overhead crane or similar equipment.

**⚠ WARNING**

**Transfer Switch weighs 350–450 lbs. Use lifting device 607064 or other device capable of lifting this weight to avoid personal injury or equipment damage.**

# BYPASSING & ISOLATING

(continued)

## RETURN TO SERVICE

This procedure explains how to return the automatic transfer switch (ATS) to service after inspection and maintenance. Observe the *Bypass Switch Position* indicator and lights). Refer to Figures 3-7, 3-8, 3-9, and 3-10.

- Slide the transfer switch (ATS) into the enclosure (isolation contacts facing inward) until its crank pins engage the latch plates on both sides. Next push in side rail carriage. Then close enclosure door.

### ⚠ WARNING

Close the enclosure door to prevent personal injury in case of electrical system fault.

### ⚠ CAUTION

Align position indicator. Do not leave the handle in an intermediate position.

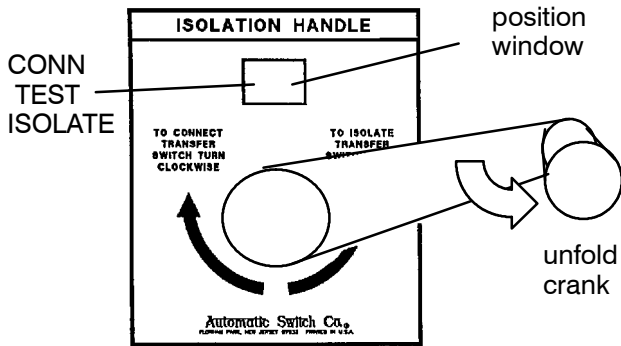

↻ clockwise – draws in the Transfer Switch

Figure 3-8. Isolation Handle.

- Turn the Isolation Handle clockwise (approx. 7 turns) until the window shows *TEST*. The ATS can be tested now without load interruption (see page 2-1).

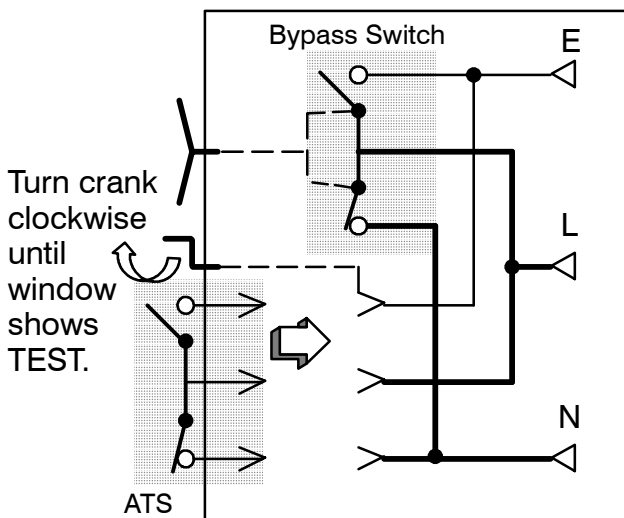

Figure 3-9. ISOLATE to TEST position.

### ⚠ CAUTION

Solenoid interlock prevents you from closing the isolation contacts until the ATS is in the same position as the Bypass Switch.

- Observe which *Bypass Switch Position* indicator is black (*NORMAL* or *EMERGENCY*) at the Bypass Switch Handle. This indicates the source connected to the load.
- Observe which *Transfer Switch Connected To* light is on (*Normal* or *Emergency*) on the door. This is the position of the Transfer Switch. If it is not in the same position as the Bypass Handle change the position of the Transfer Switch as follows:

To change the position of transfer switch

Operate to NORMAL	Operate to EMERGENCY
Turn Transfer Control switch to <i>Retransfer Delay Bypass</i> .	Turn Transfer Control switch to <i>Transfer Test</i> (hold 15 seconds).*
<i>Connected To Normal</i> light should come on.	<i>Connected To Emergency</i> light should come on.

\* If Feature 2B time delay is used, there will be a delay before transfer to Emergency.

**NOTE:** With Normal available, the automatic transfer switch will not stay in the emergency position unless Feature 3A time delay is used (at least 30 seconds).

### ⚠ WARNING

Do not close the isolation contacts unless the Transfer Switch (ATS) and Bypass Switch are in the same position!

- When the transfer switch is in the same position as the Bypass Switch handle, continue turning the Isolation Handle clockwise (about 16 turns) until the window shows *CONN* (connected).

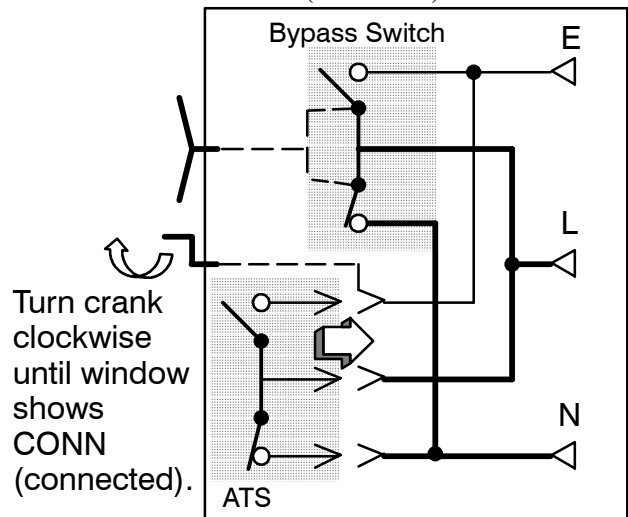

Figure 3-10. TEST to CONNECTED position. Now continue to the next page for instructions on how to return the Bypass Handle to the OPEN position.

# BYPASSING & ISOLATING

(continued)

## RETURN TO SERVICE continued\*

This procedure explains how to return the Bypass Switch Handle to the OPEN position. The Bypass Handle must be in the *CLOSED* position (yellow indicator on *NORMAL* or *EMERGENCY*) and the Isolation Handle must be in the *TEST* position (window). If the handles are not in these positions, refer to **Return to Service** on page 3-3. See Figures 3-11, 3-12, and 3-13.

⚠ CAUTION

**You can only bypass to the same source that the ATS is connected. Solenoid interlock prevents incorrect operation.**

- 1 Observe which Bypass Switch Position indicator is yellow (*NORMAL* or *EMERGENCY*) at the Bypass Switch Handle. This indicates the source connected to the load.
- 2 Un-Bypass to same source as the Bypass Switch Position as follows (select Normal or Emergency).

Indicator shows:

yellow ● EMERGENCY CLOSED when ATS is bypassed to Emergency or

yellow ● NORMAL when ATS is bypassed to Normal Source.

Indicator shows:

green ● OPEN when the ATS is not bypassed.

**To un-Bypass Normal** push in handle all the way & turn it counterclockwise.\*

**To un-Bypass Emergency** pull out handle all the way & turn it counterclockwise.\*

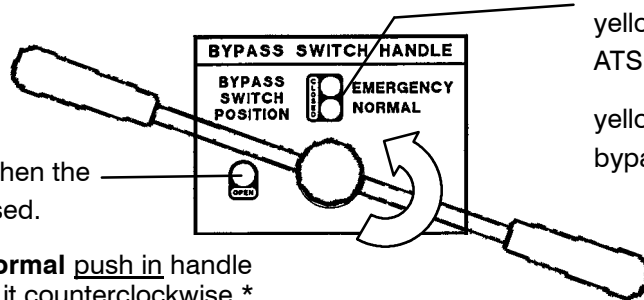

Figure 3-11. Bypass Handle and position indicators.

### To Un-Bypass Normal Source\*

(Load connected to Normal Source)

The *Transfer Switch Connected To Normal* light is on and *Transfer Switch Connected To Emergency* light is off.

**Push in\*** the Bypass Handle then turn it counterclockwise until *Bypass Switch Position* shows OPEN (green indicator). The *Unit Not in Automatic* light should be off.

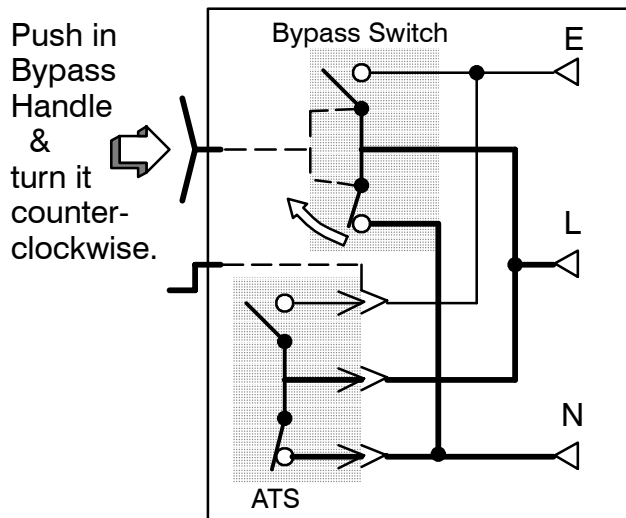

Figure 3-12. Un-Bypass Normal.

### To Un-Bypass Emergency Source\*

(Load connected to Emergency Source)

The *Transfer Switch Connected To Emergency* light is on and *Transfer Switch Connected To Normal* light is off.

**Pull out\*** the Bypass Handle then turn it counterclockwise until *Bypass Switch Position* shows OPEN (green indicator). The *Unit Not in Automatic* light should be off.

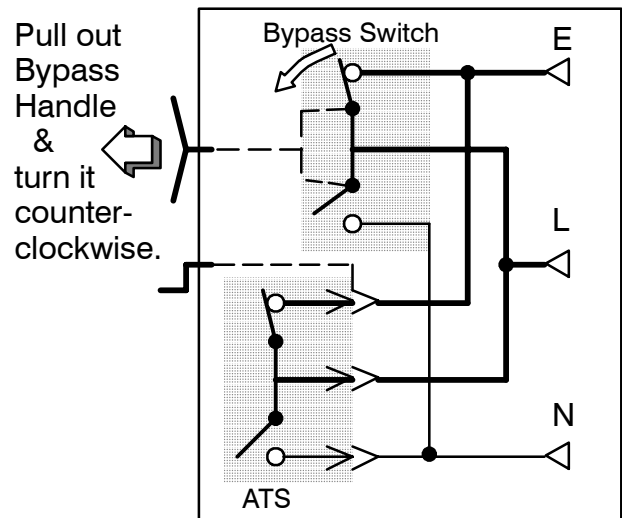

Figure 3-13. Un-Bypass Emergency.

The Automatic Transfer & Bypass-Isolation Switch should be left in this position.

\* **NOTE:** When Accessory 66A (reversed Normal & Emergency connections) is specified, the handle push-pull operation is reversed. Follow instructions on the door.

# INDEX

## A

auxiliary circuits, 1–2

## B

bypassing the ATS, 3–1

## C

catalog number, 1–1

cleaning, 2–1

connections  
power, 1–2

controller  
disconnecting, 2–1  
see *Controller User's Guide*

## E

electrical operation, 1–4

Emergency Source Accepted light,  
1–3

engine starting contacts, 1–2

## F

foundation, 1–1

frequency, generator, 2–2

functional test, 1–3, 1–4

## H

harness, 1–2  
disconnect plugs, 2–1

## I

inspection, 3–1

installation, 1–1

isolating the ATS, 3–2

## L

lights, 1–3, 1–4

load connected to emergency, 1–4

load connected to normal, 1–4

lubrication, 2–1

## M

maintenance, preventive, 2–1

maintenance handle, 2–2  
warning, 2–2

manual load transfer, 2–2  
warning, 2–2

## N

nameplate, 1–1

Normal Source Accepted light, 1–3

## O

operation  
electrical, 1–4  
manual, 2–2  
warning, 2–2

## P

parts, 2–1

phase rotation check, 1–3

preventive maintenance, 2–1

problem, 2–2

## R

rating label, cover

replacement parts, 2–1

return to service, 3–3, 3–4

## S

service  
ASCO Services, Inc. (ASI), 2–1

settings  
see *Controller User's Guide*

## T

test, functional, 1–3, 1–4

testing power cables, 1–2

time delays, 2–1  
see *Controller User's Guide*

Transfer Control selector switch  
Retransfer Delay Bypass, 1–4  
Transfer Test, 1–4

Transfer Switch Connected To  
Emergency light, 1–4

Transfer Switch Connected To  
Normal light, 1–4

transfer test, 1–3, 2–1

transfer to emergency, 1–4, 2–1

transfer to normal, 1–4, 2–1

troubleshooting, 2–2

## V

voltage checks, 1–3

voltage, pickup and dropout settings  
see *Controller User's Guide*