

Operator's Manual

ASCO® 7000 Series ACTB Automatic Closed-Transition Transfer & Bypass-Isolation Switches G-design, 1000 through 3000 amp. sizes

TABLE OF CONTENTS

	section-page
INSTALLATION	1-1
Shipping Angle Removal, Foundation	1-1
Power Conductors	1-2
Engine Starting & Auxiliary Circuits	1-2
Functional Test	1-3, 1-4
TESTING & SERVICE	2-1
Transfer Test	2-1
Preventive Maintenance	2-1
Disconnecting the Controller	2-1
Manual Load Transfer	2-2
Trouble-Shooting	2-2
BYPASSING & ISOLATING	3-1
Bypassing the ATS	3-1
Isolating the ATS	3-2
Return to Service	3-3, 3-4
INDEX	back cover

Refer to the outline and wiring drawings provided with your 7000 Series ACTB for all installation and connection details and accessories.

Refer to *Group 5 Controller User's Guide* 381333-126 for ATS status display messages, time delays, pickup & dropout settings, and adjustments.

Rating Label

Each 7000 Series ACTB contains a rating label to define the loads and fault circuit withstand/closing ratings. Refer to the label on the Transfer Switch for specific values.

WARNING

Do not exceed the values on the rating label. Exceeding the rating can cause personal injury or serious equipment damage.

Nameplate

The Transfer Switch nameplate includes data for each specific 7000 Series 7ACTB. Use the switch only within the limits shown on this nameplate. A typical Catalog Number is shown below with its elements explained:

An experienced licensed electrician must install ATS.

Catalog Number Identification

Typical 7000 Series ACTB catalog no. for overlapping neutral, 3 pole, 1200 amp., 480 V, in Type 1 enclosure:

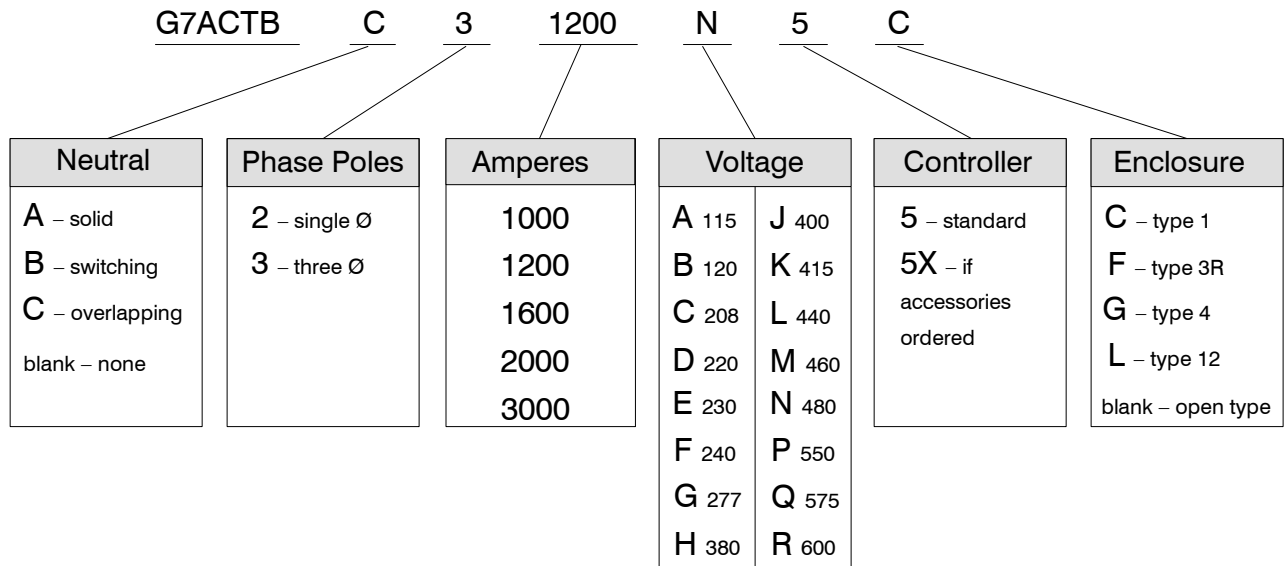

SECTION 1 INSTALLATION

The ASCO 7000 Series Automatic Closed–Transition Transfer & Bypass–Isolation Switch (ACTB) consists of an upper bypass–isolation switch, a transfer switch, a monitoring and transfer controller, and door–mounted controls. The ACTB is factory wired and tested. Installation requires removal of the shipping skid then securing the enclosure to the supporting foundation.

Remove the Shipping Skid

Open the front lower door and remove the two front lag screws securing the enclosure to the wood skid. Next remove the rear lower panel and remove the two rear lag screws securing the enclosure to the wood skid.

Supporting foundation and mounting

The supporting foundation for the enclosure must be level and straight. Allow at least 35 inches in front of the enclosure for draw out of the Transfer Switch. Refer to the enclosure outline drawing included with the 7000 Series ACTB for all mounting details including door opening space.

If bottom cable entry is used, the foundation must be prepared so that the conduit stubs are located correctly. Refer to the appropriate enclosure outline drawing for specified cable entrance area and location. Provide cable bending space and clearance to live metal parts. When a concrete floor is poured, use interlocking conduit spacer caps or a wood or metal template to maintain proper conduit alignment.

Mounting

Refer to the enclosure outline drawing furnished with this switch and mount the 7000 Series ACTB according to the details and instructions shown on the drawing.

Remove three Shipping Angles from the Transfer Switch

Open the lower front door. The Transfer Switch carriage is secured to the frame for shipment. Remove the three shipping angle (1 upper left, 1 upper right, 1 lower right).

CAUTION

To prevent serious damage, remove three shipping angles from the Transfer Switch carriage. Do not turn the Isolation Handle until they are removed!



Figure 1-1. Typical enclosure,

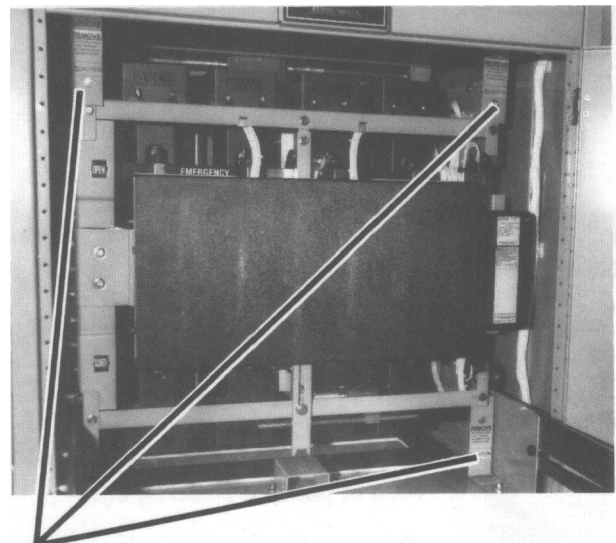

remove 3 shipping L-angles from transfer switch

Figure 1-2. Remove three shipping L-angles.

INSTALLATION (continued)

⚠ DANGER

De-energize the conductors before making any line or auxiliary circuitry connections. Be sure that Normal and Emergency line connections are in proper phase rotation. Place engine generator starting control in the OFF position. Make sure engine generator is not in operation.

Testing Power Conductors

Do not connect the power conductors to the ACTB until they are tested. Installing power cables in conduit, cable troughs, and ceiling-suspended hangers often requires considerable force. The pulling of cables can damage insulation and stretch or break the conductor's strands. For this reason, after the cables are pulled into position, and before they are connected they should be tested to verify that they are not defective or have been damaged during installation.

⚠ CAUTION

Protect the switch from construction grit and metal chips to prevent malfunction or shortened life for the ACTB switch.

Connecting Power Conductors

A *Wiring Diagram* is furnished with the ACTB. All wiring must be made in accordance with the local codes. After the power cables have been tested, connect them to the appropriate terminal lugs on the Bypass Switch as shown on the wiring diagram provided with this ACTB. Make sure that the lugs provided are suitable for use with the cables being installed. Standard terminal lugs are solderless screw type and will accept the wire sizes listed on the drawings provided with the ACTB. Be careful when stripping insulation from conductors; avoid nicking or ringing the conductor. Remove surface oxides from conductors by cleaning with a wire brush. Follow conductor manufacturer's instructions when aluminum conductor is used. Apply joint compound to conductor, then carefully wipe away excess compound. Tighten the cable lugs to the torque specified on the rating label.

⚠ CAUTION

Be sure that the Normal and Emergency power connections are in proper phase rotation.

Bus Connections

If bus connection is used, use SAE grade 5 hardware to connect bus to appropriate terminal plates on bypass switching device. Wipe off bus surfaces before they are joined. If bus is dirty, gently clean surfaces with a non-flammable solvent. Avoid touching cleaned surfaces.

⚠ CAUTION

Do not breathe cleaning solvent vapors.

Use SAE grade 5 hardware and tighten the bolted joints to the torque specified in Table 2-1.

⚠ CAUTION

The reliability of the connection depends on how clean and how tight the joint is.

Table 2-1. Tightening torque values for bolted joints.

Bolt Diameter (Grade 5 hardware) in inches	Recommended Tightening Torque in foot pounds
5/16	12
3/8	20
1/2	50
5/8	95

Harnesses

All internal connections are made at the factory. The bypass switch, transfer switch, and control panel are joined together by an interconnecting wire harness. The disconnect plugs are already engaged on enclosed switches. For open-type switches, the plugs must be engaged after installation is completed. Align harness plugs with sockets in the control and push them together until they are secure.

Controller Ground

A grounding wire must be connected to the controller's lower left mounting stud. Because the controller is mounted on the enclosure door, a conductive strap must be used between the enclosure and the door. This connection provides proper grounding which does not rely upon the door hinges.

Engine Starting Contacts and Auxiliary Circuits

The engine control contact signal connections and auxiliary circuits are located on terminal block TB as shown on the *Wiring Diagram* provided with the ACTB. Connect the signal wires to the appropriate terminals.

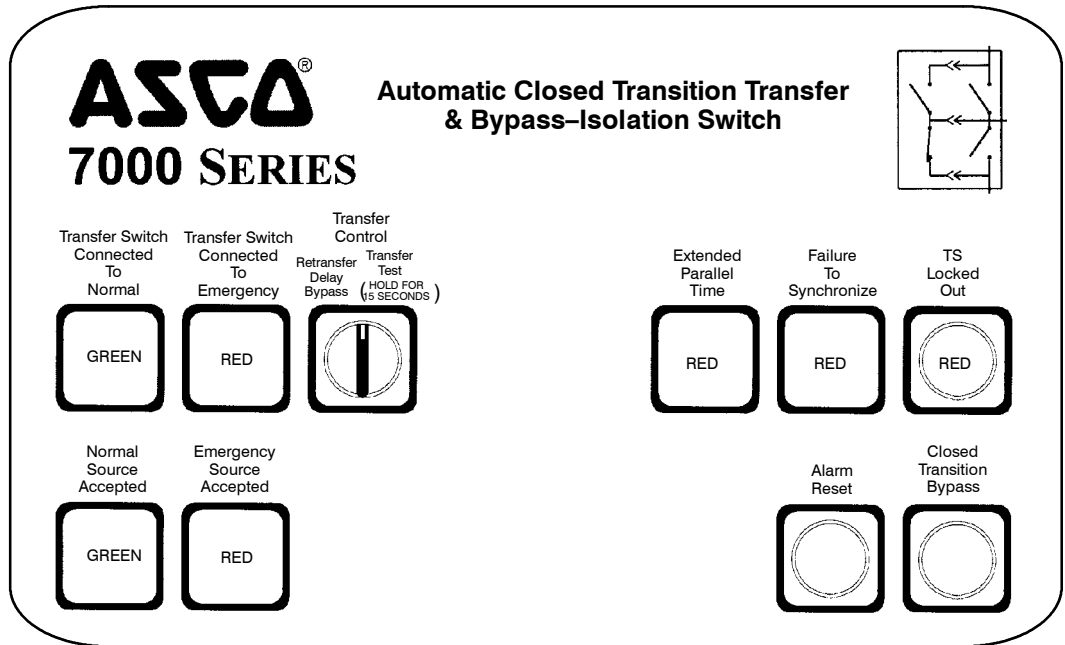

Figure 1-3. Standard controls and indicators.

Functional Test

Read all instructions on the *Wiring Diagrams* and labels affixed to the ACTB. Note the control features that are provided and review their operation before proceeding.

After installing the ACTB check the following:

- Bypass Handle should be in the *OPEN* position.
- Isolation Handle should be in the *CLOSED* position.
- CN transfer switch should be *CLOSED*.
- CE transfer switch should be *OPEN*.

If handles are not in correct positions, follow instructions for Bypassing and Isolating the automatic transfer switch in **Section 3**. **Do not force the handles**. Electrical interlocks prevent a wrong sequence of operation.

1 – Voltage Checks

First check nameplate on transfer switch; rated voltage must be the same as normal and emergency line voltages.

⚠ DANGER

Use extreme caution when using a meter to measure voltages. Do not touch power terminals; shock, burns, or death could result !

Perform steps 1–6 at the right. Observe the status lights. See Figure 1–3.

- Black square means light is on.
- White square means light is off.

* If necessary, adjust voltage regulator on generator per the manufacturer’s recommendations. The ACTB will respond only to rated voltage specified on the nameplate.

Now continue to **2 – Electrical Operation** on next page.

1	Close the normal source circuit breaker. The <i>Transfer Switch Connected To Normal</i> and the <i>Normal Source Accepted</i> lights should come on.	
2	Use an accurate voltmeter to check phase to phase and phase to neutral voltages present at the transfer switch normal source terminals.	
3	Close the emergency source circuit breaker. Turn the Engine Control switch to <i>Run</i> to start the generator. The <i>Transfer Switch Connected To Normal</i> & <i>Emergency Source Accepted</i> lights should come on.	
4	Use an accurate voltmeter to check phase to phase and phase to neutral voltages present at the transfer switch emergency source terminals.*	
5	Use a phase rotation meter to check phase rotation of emergency source; it must be the <u>same</u> as the normal source.	
6	Turn Engine Control switch to <i>Auto</i> to stop the generator. The <i>Emergency Source Accepted</i> light should go off. Then put the starting control selector switch (on generator set) in <i>automatic</i> position. Close enclosure door.	

INSTALLATION (continued)

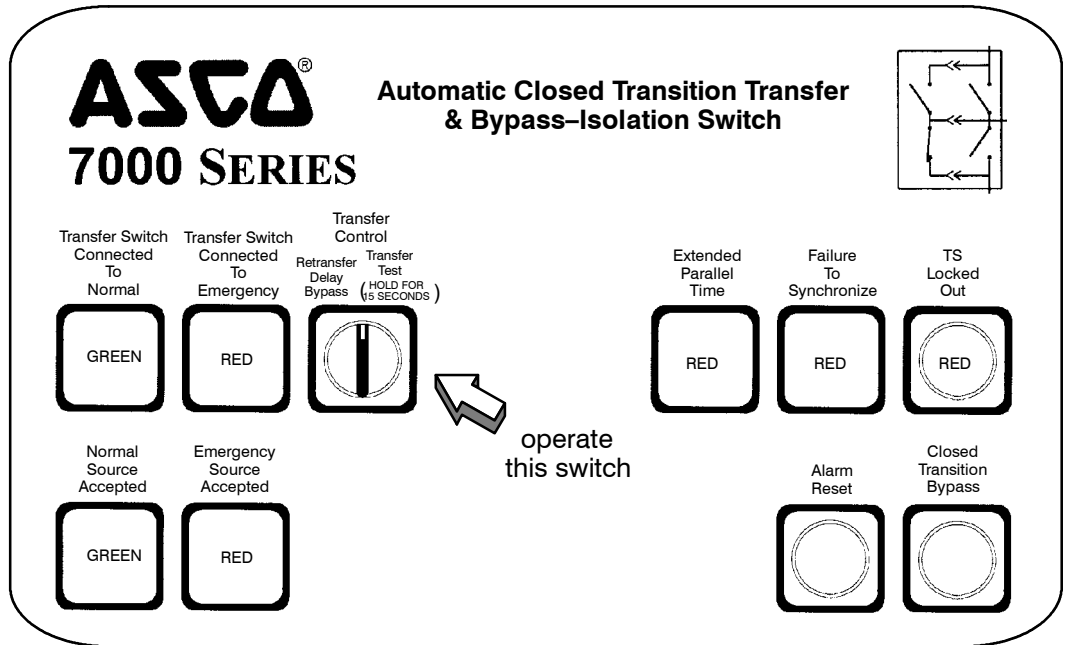

Figure 1-4. Standard controls and indicators.

2 – Electrical Operation

This procedure checks electrical operation of the ATS.

⚠ WARNING

Be sure to close the enclosure door before proceeding to prevent personal injury in case of electrical system fault.

Transfer Test

The ATS should be bypassed and isolated. Both normal and emergency sources must be available and the emergency source generator (if used) must be capable of being started; put engine starting control in *automatic* position. The *Transfer Switch Connected to Normal* light and the *Normal Source Accepted* light should be on.

1. Turn the **Isolation Handle** clockwise (approximately 7 turns) until the window shows *TEST* position.
NOTE: The engine generator may be signalled to start while turning the Isolation Handle. If emergency source is available, the ATS may operate to the emergency position. If it does, operate **Retransfer Delay Bypass** switch.
2. Perform steps 1–4 at right. Observe the status lights.
 - Black square means light is on.
 - White square means light is off.
3. Turn the **Isolation Handle** clockwise (approximately 16 turns) to the *CONN* (connected) position.
4. Push in the **Bypass Handle** and turn it counterclockwise until the *OPEN* indicator shows green.

This completes the Functional Test of the ACTB.

1	Turn and <u>hold</u> Transfer Control switch clockwise to <i>Transfer Test</i> until the engine starts and runs (within 15 sec.). The <i>Emergency Source Accepted</i> light should come on.	
2	Transfer switch CE closes and then Transfer Switch CN opens (closed-transition overlap). The <i>Transfer Switch Connected to Emergency</i> light should come on and the <i>Transfer Switch Connected to Normal</i> light should go off (you might see and hear the brief overlap transfer).	
3	Transfer switch will operate back to Normal position after Feature 3A time delay. For immediate retransfer turn Transfer Control counterclockwise to <i>Retransfer Delay Bypass</i> . The <i>Transfer Switch Connected To Normal</i> light should come on; <i>Transfer Switch Connected to Emergency</i> light should go off.	
4	The engine-generator will stop after the Feature 2E time delay (unloaded running engine cool-down). The <i>Emergency Source Accepted</i> light should go off.	

SECTION 2 TESTING & SERVICE

TRANSFER TEST

Test the Automatic Closed-Transition Transfer Switch portion of the 7000 Series ACTB at least once a month. This procedure checks the electrical operation of the Transfer Switch and Control Panel. Turn the **Engine Control** switch to *Auto* and put the engine-generator starting control (at the engine-generator set) in automatic mode.

In the following test the generator will start, the load will be transferred to the Emergency source, then back to the Normal source. An interruption to the load will occur, unless the the Transfer Switch contacts are bypassed before the test. See pages 3-1 and 3-2 for bypassing & isolating instructions if no interruption of load is required.

WARNING

Be sure to close the enclosure door before proceeding to prevent personal injury in case of electrical system fault.

Perform the four-step **Electrical Operation – Transfer Test** procedure on page 1-4.

PREVENTIVE MAINTENANCE

Reasonable care in preventive maintenance will insure high reliability and long life for the 7000 Series ACTB. An annual preventive maintenance program is recommended.

ASCO Services, Inc. (ASI) is ASCO Power Technologies' national service organization. ASI can be contacted at 1-800-800-2726 for information on preventive maintenance agreements.

Checklist for Yearly Inspection

DANGER

Hazardous voltage capable of causing shock, burns, or death is used in this switch. Deenergize both Normal – Emergency power sources before performing inspections!

- Clean the ATS enclosure.** Brush and vacuum away any excessive dust accumulation. Remove any moisture with a clean cloth.
- Check the transfer switch contacts.** Remove transfer switch barriers and check the condition of the contacts. Replace contacts when pitted or worn excessively. Reinstall the barriers carefully.
- Maintain transfer switch lubrication.** If switch is subjected to severe dust or abnormal operating conditions, renew factory lubrication on all movements and linkages. Relubricate solenoid operator if TS coil is replaced. Don't use oil; order *lubrication kit 75-100*.
- Check all cable connections & retighten them.**

REPLACEMENT PARTS

Replacement parts are available in kit form. When ordering parts provide the Serial No., Bill of Material No. (BOM), and Catalog No. from the transfer switch nameplate. For service call ASCO Services at 1-800-800-2726; you will be put in contact with your local ASI office.

DISCONNECTING THE CONTROLLER

The harness disconnect plugs are furnished for repair purposes only and should not have to be unplugged. If the control panel must be isolated, follow these steps:

DANGER

Bypass-Isolation Switch is energized! Do not touch isolation contact fingers; shock, burns, or death could result!

Disconnecting the Plugs

1. Bypass and Isolate the Automatic Transfer Switch.
2. Open the upper enclosure door.
3. Separate the two quick disconnect plugs by squeezing the latches. Do not pull on the harness wires.

Reconnecting the Plugs

1. The ATS should be still bypassed and isolated.
2. The two harness plugs and sockets are keyed. Carefully align the plugs with the sockets and press straight in until the latches click.
3. Close the enclosure doors.
4. Follow *Return to Service* instructions on page 3-3.

TESTING & SERVICE (continued)

TROUBLE-SHOOTING

Note any optional accessories that may be furnished on the ACTB and review their operation. Refer to any separate drawings and/or instructions that may be packed with the ACTB.

⚠ DANGER

Hazardous voltage capable of causing shock, burns, or death is used in this switch. Do not touch the power or load terminals of the switch!

Table 2-1. Trouble-Shooting Checks.

PROBLEM	CHECK IN NUMERICAL SEQUENCE		
	1 OPERATION	2 GEN-SET	3 VOLTAGE
Engine-generator set does not start when the Transfer Control switch is turned and held in <i>Transfer Test</i> position or when normal source fails.	Hold <i>Transfer Test</i> switch 15 seconds or the outage must be long enough to allow for Feature 1C time delay plus engine cranking and starting.	Starting control must be in the automatic position. Batteries must be charged and connected. Check wiring to engine starting contacts.	-
Transfer switch does not transfer the load to the emergency source after the engine-generator set starts.	Wait for Feature 2B time delay to time out.	Generator output circuit breaker must be closed. Generator frequency must be at least 95% of nominal (57 Hz for a 60 Hz system.) *	Voltmeter should read at least 90% of nominal phase to phase voltage between terminals EA and EC (or EL1 and EL2 for 2 pole switches) *
Transfer switch does not transfer the load to normal source when normal returns or when the Transfer Control switch is released.	Wait for Feature 3A time delay to time out.	-	Voltmeter should read at least 90% of nominal phase to phase voltage between terminals NB and NC, NC and NA, and NA and NB (or NL1 and NL2 for 2 pole switches).
Gen. does not stop after load retransfer to normal source.	Wait for Feature 2E time delay to time out.	Starting control must be in the automatic position.	-
<i>Failure to Synchronize</i> light comes on.	Conditions of Normal or Emergency Sources not suitable for closed transition transfer. Recheck voltage and frequency of both sources. Press Alarm Reset pushbutton.		
<i>Extended Parallel Time</i> light comes on.	CN and CE contacts are closed longer than setting in the Control Panel. Open the disconnected source circuit breaker, then call your nearest ASCO Service Center for assistance.		
<i>TS Locked Out</i> light comes on.	Transfer lockout operation has occurred; transfer switch is disabled from automatic operation. Open the disconnected source circuit breaker, then call your nearest ASI for assistance.		

* These are factory settings. Refer to **Controller User's Guide**.

If the problem is isolated to circuits on the controller or the transfer switch, call your local ASCO Power Technologies sales office or ASI at 1-800-800-2726. Furnish the Serial No. and Catalog No. from the transfer switch nameplate.

MANUAL LOAD TRANSFER

This procedure manually transfers load to other source if the Transfer Switch or Control Panel are out of service.

⚠ WARNING

Close enclosure doors to prevent personal injury in case of electrical system fault.

1. Be sure that the Bypass Handle is *CLOSED* on either Emergency or Normal (see page 3-1).
2. Be sure that the Isolation Handle is in the *TEST* or *ISOLATE* position (see page 3-2).
3. Turn the Bypass Handle counterclockwise to *OPEN* the Bypass Switch. Then Bypass to the other source (see page 3-1).

MAINTENANCE HANDLE

⚠ DANGER

Bypass and isolate the Transfer Switch before using the maintenance handle!
See pages 3-1 and 3-2. Remove the hub and handle after using them and store on frame.

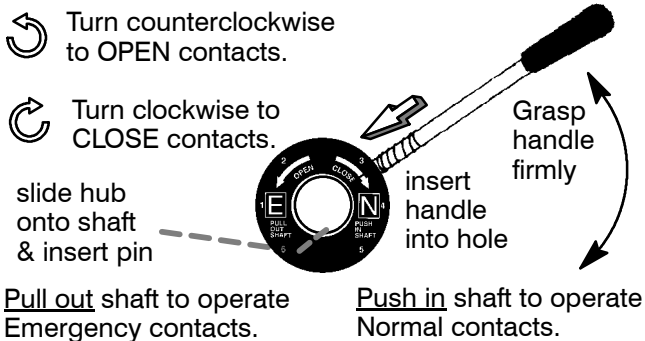

SECTION 3 BYPASSING & ISOLATING

BYPASSING THE ATS*

This procedure explains how to Bypass the closed automatic transfer switch contacts. Bypassing is required before the ATS can be tested or isolated. The Bypass Handle must be in the *OPEN* position (green indicator) and the Isolation Handle must be in the *CLOSED* position (window). See Figures 3-1, 3-2, and 3-3.

⚠ CAUTION

You can only bypass to the same source that the ATS is connected. Solenoid interlock prevents incorrect operation.

1. Observe which *Transfer Switch Connected To* light is on (*Normal* or *Emergency*) on the door. This is the position of the automatic transfer switch.
2. Bypass to the same source as connected to transfer switch as follows (select Normal or Emergency).

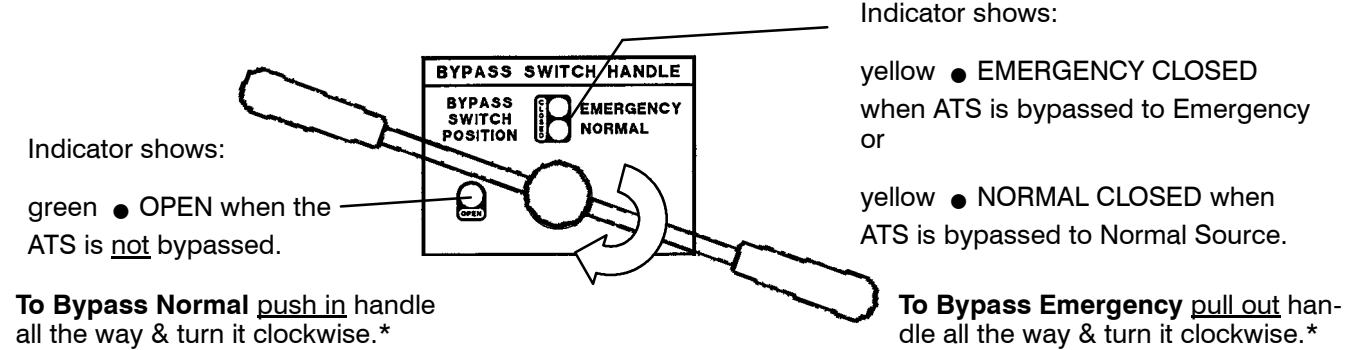

Figure 3-1. Bypass Handle and position indicators.

To Bypass Normal Source*

(Load connected to Normal Source)

The *Transfer Switch Connected To Normal* light is on and *Transfer Switch Connected To Emergency* light is off.

Push in* the Bypass Handle all the way, then turn it clockwise until *Bypass Switch Position* shows CLOSED on NORMAL (yellow indicator). The red light *Unit Not In Automatic* will flash.

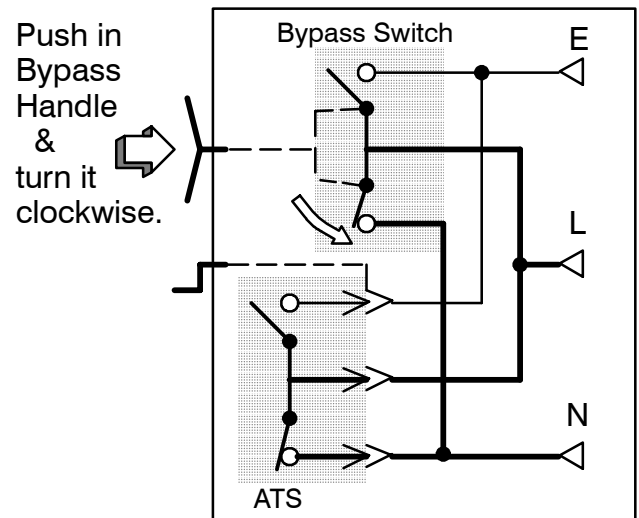

Figure 3-2. Bypass to Normal.

To Bypass Emergency Source*

(Load connected to Emergency Source)

The *Transfer Switch Connected To Emergency* light is on and *Transfer Switch Connected To Normal* light is off.

Pull out* the Bypass Handle all the way, then turn it clockwise until *Bypass Switch Position* shows CLOSED on EMERGENCY (yellow indicator). The red light *Unit Not In Automatic* will flash.

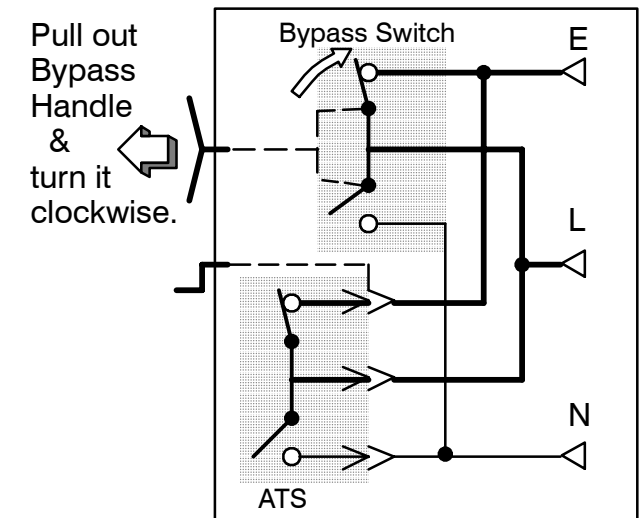

Figure 3-3. Bypass to Emergency.

The automatic transfer switch can now be put in the *TEST* or *OPEN* position. See **ISOLATING** on page 3-2.

* **NOTE:** When Accessory 66A (reversed Normal & Emergency connections) is specified, the handle push-pull operation is reversed. Follow instructions on the door.

BYPASSING & ISOLATING

(continued)

ISOLATING THE ATS

Isolating is required before any service work can be performed on the automatic transfer switch (ATS). Refer to Figures 3-4, 3-5, 3-6, and 3-7.

1. Bypass the closed automatic transfer switch contacts. See **BYPASSING** on page 3-1.

⚠ CAUTION

Align position indicator. Do not leave the handle in an intermediate position.

2. Turn the Isolation Handle counterclockwise (approx. 16 turns) until window shows *TEST*. The ATS can be tested now without load interruption (see page 2-1).

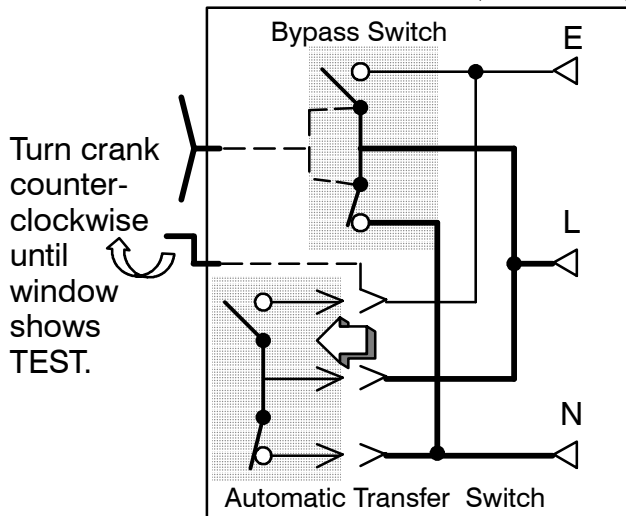

Figure 3-4. *CONNECTED* to *TEST* position.

3. Continue turning Isolation Handle counterclockwise (approx. 7 turns) until the window shows *ISOLATE*.

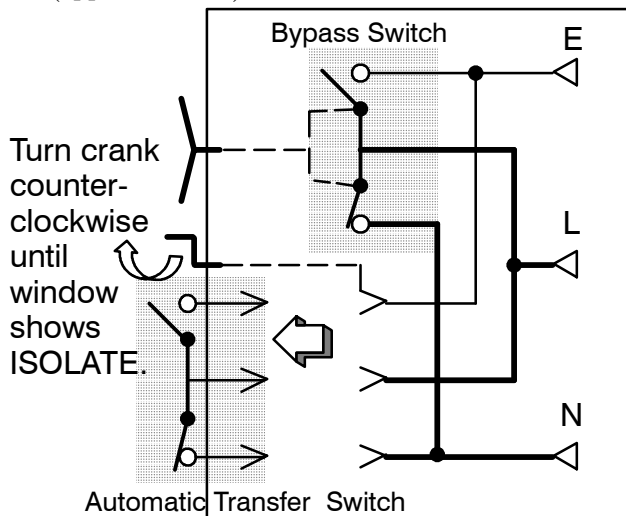
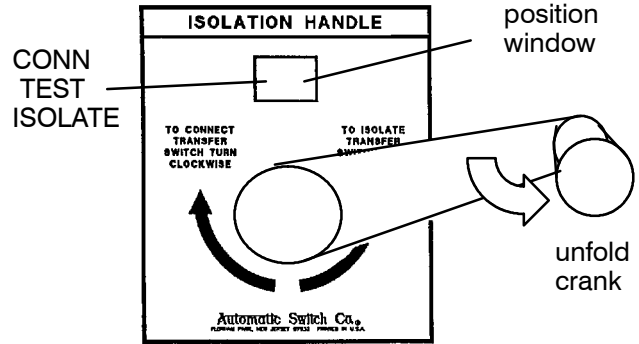

Figure 3-5. *TEST* to *ISOLATE* position.

4. Open the lower enclosure door. Pull out the side rail carriage then roll out the transfer switch. It can be safely inspected in this position. The transfer switch can also be removed for easier maintenance operations.



counterclockwise – draws out transfer switching device

Figure 3-6. Isolation Handle.

NOTE: In the *TEST* position the transfer switching device solenoid operator circuit is energized through secondary disconnects.

⚠ DANGER

Hazardous voltage capable of causing electrical shock, burns, or death; do not touch any control circuit terminals.

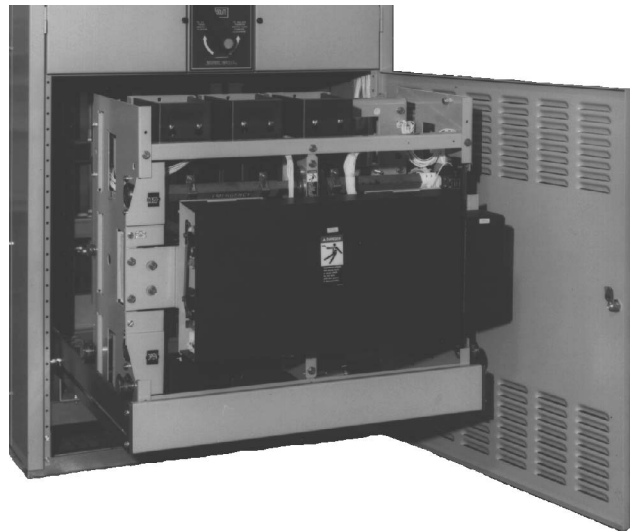

Figure 3-7. Transfer switching device isolated and pulled out for inspection.

See page 2-2 for maintenance handle use. A lifting yoke kit 607064 is available to facilitate lifting by using an overhead crane or similar equipment.

⚠ WARNING

Transfer Switch weighs 350–450 lbs. Use lifting device 607064 or other device capable of lifting this weight to avoid personal injury or equipment damage.

BYPASSING & ISOLATING

(continued)

RETURN TO SERVICE

This procedure explains how to return the automatic transfer switch (ATS) to service after inspection and maintenance. Observe the *Bypass Switch Position* indicator and lights). Refer to Figures 3-7, 3-8, 3-9, and 3-10.

- Slide the transfer switch (ATS) into the enclosure (isolation contacts facing inward) until its crank pins engage the latch plates on both sides. Next push in side rail carriage. Then close enclosure door.

⚠ WARNING

Close the enclosure door to prevent personal injury in case of electrical system fault.

⚠ CAUTION

Align position indicator. Do not leave the handle in an intermediate position.

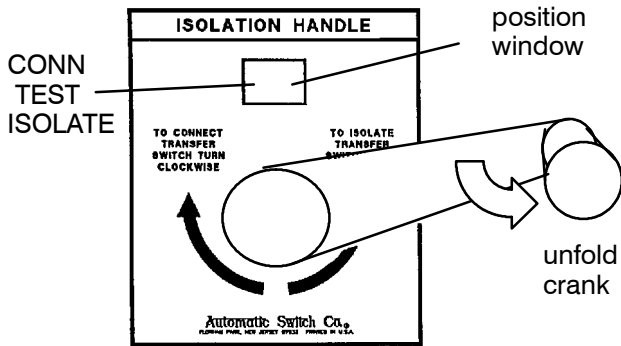

↻ clockwise – draws in the Transfer Switch

Figure 3-8. Isolation Handle.

- Turn the Isolation Handle clockwise (approx. 7 turns) until the window shows *TEST*. The ATS can be tested now without load interruption (see page 2-1).

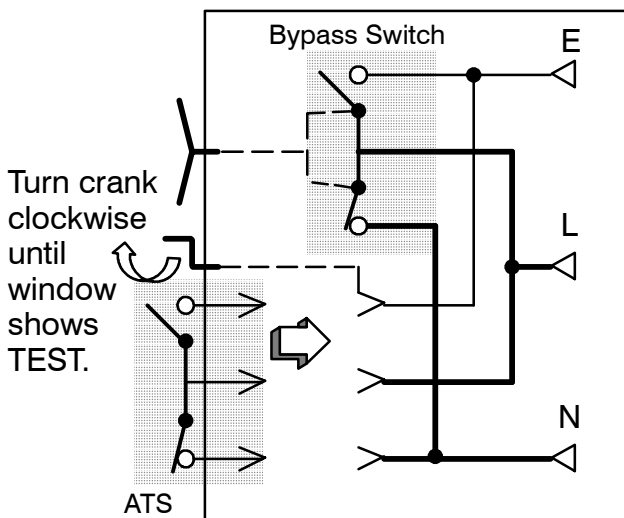

Figure 3-9. ISOLATE to TEST position.

⚠ CAUTION

Solenoid interlock prevents you from closing the isolation contacts until the ATS is in the same position as the Bypass Switch.

- Observe which *Bypass Switch Position* indicator is black (*NORMAL* or *EMERGENCY*) at the Bypass Switch Handle. This indicates the source connected to the load.
- Observe which *Transfer Switch Connected To* light is on (*Normal* or *Emergency*) on the door. This is the position of the Transfer Switch. If it is not in the same position as the Bypass Handle change the position of the Transfer Switch as follows:

To change the position of transfer switch

Operate to NORMAL	Operate to EMERGENCY
Turn Transfer Control switch to <i>Retransfer Delay Bypass</i> .	Turn Transfer Control switch to <i>Transfer Test</i> (hold 15 seconds).*
<i>Connected To Normal</i> light should come on.	<i>Connected To Emergency</i> light should come on.

* If Feature 2B time delay is used, there will be a delay before transfer to Emergency.

NOTE: With Normal available, the automatic transfer switch will not stay in the emergency position unless Feature 3A time delay is used (at least 30 seconds).

⚠ WARNING

Do not close the isolation contacts unless the Transfer Switch (ATS) and Bypass Switch are in the same position!

- When the transfer switch is in the same position as the Bypass Switch handle, continue turning the Isolation Handle clockwise (about 16 turns) until the window shows *CONN* (connected).

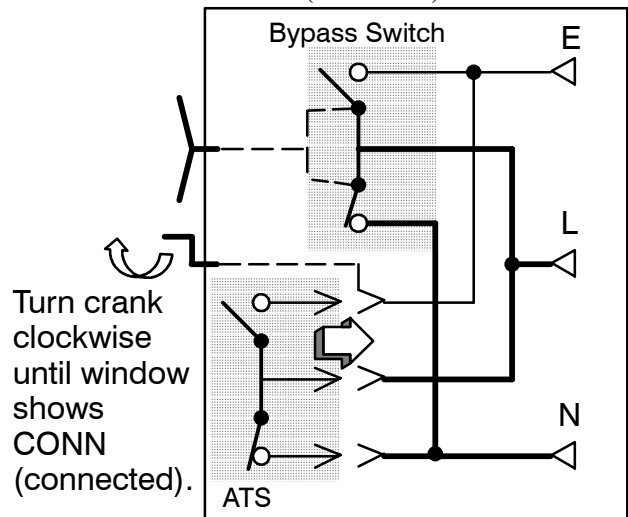

Figure 3-10. TEST to CONNECTED position. Now continue to the next page for instructions on how to return the Bypass Handle to the OPEN position.

BYPASSING & ISOLATING

(continued)

RETURN TO SERVICE continued*

This procedure explains how to return the Bypass Switch Handle to the OPEN position. The Bypass Handle must be in the *CLOSED* position (yellow indicator on *NORMAL* or *EMERGENCY*) and the Isolation Handle must be in the *TEST* position (window). If the handles are not in these positions, refer to **Return to Service** on page 3-3. See Figures 3-11, 3-12, and 3-13.

⚠ **CAUTION**

You can only bypass to the same source that the ATS is connected. Solenoid interlock prevents incorrect operation.

- 1 Observe which Bypass Switch Position indicator is yellow (*NORMAL* or *EMERGENCY*) at the Bypass Switch Handle. This indicates the source connected to the load.
- 2 Un-Bypass to same source as the Bypass Switch Position as follows (select Normal or Emergency).

Indicator shows:

yellow ● EMERGENCY CLOSED when ATS is bypassed to Emergency or

yellow ● NORMAL when ATS is bypassed to Normal Source.

Indicator shows:

green ● OPEN when the ATS is not bypassed.

To un-Bypass Normal push in handle all the way & turn it counterclockwise.*

To un-Bypass Emergency pull out handle all the way & turn it counterclockwise.*

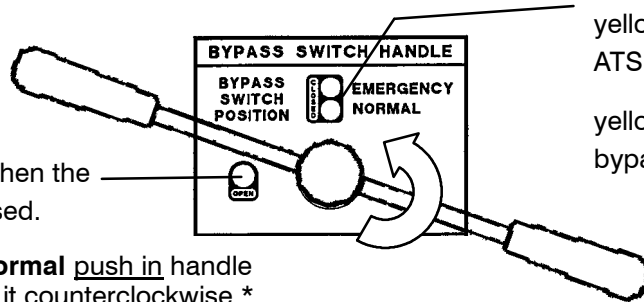

Figure 3-11. Bypass Handle and position indicators.

To Un-Bypass Normal Source*

(Load connected to Normal Source)

The *Transfer Switch Connected To Normal* light is on and *Transfer Switch Connected To Emergency* light is off.

Push in* the Bypass Handle then turn it counterclockwise until *Bypass Switch Position* shows OPEN (green indicator). The *Unit Not in Automatic* light should be off.

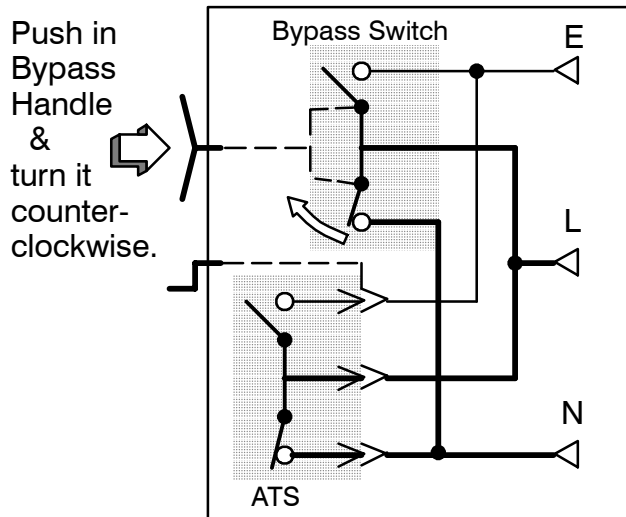

Figure 3-12. Un-Bypass Normal.

To Un-Bypass Emergency Source*

(Load connected to Emergency Source)

The *Transfer Switch Connected To Emergency* light is on and *Transfer Switch Connected To Normal* light is off.

Pull out* the Bypass Handle then turn it counterclockwise until *Bypass Switch Position* shows OPEN (green indicator). The *Unit Not in Automatic* light should be off.

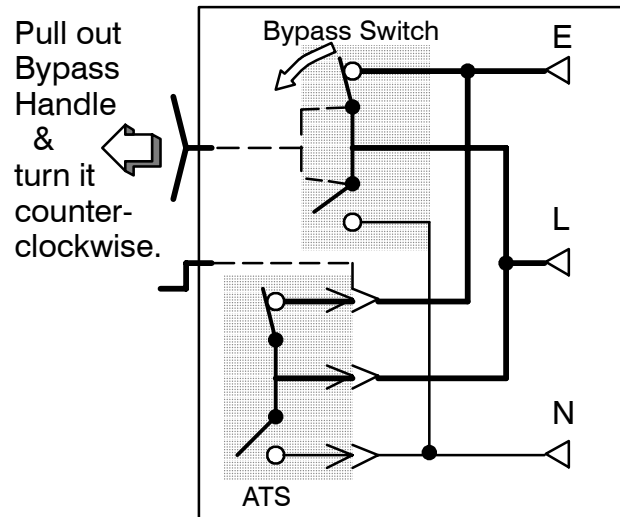

Figure 3-13. Un-Bypass Emergency.

The Automatic Closed-Transition Transfer & Bypass-Isolation Switch should be left in this position.

* **NOTE:** When Accessory 66A (reversed Normal & Emergency connections) is specified, the handle push-pull operation is reversed. Follow instructions on the door.

INDEX

A

Alarm Reset pushbutton, 1-4, 2-2
auxiliary circuits, 1-2

B

bus connections, 1-2
bypassing the ATS, 3-1

C

catalog number, cover
cleaning, 2-1
closed-transition transfer, 1-4
connections
 line, 1-1
controller
 disconnecting, 2-1
 see *Controller User's Guide*

E

electrical operation, 1-4
Emergency Source Accepted light,
 1-3
Engine Control selector switch
 Auto position, 2-1
engine starting contacts, 1-2
Extended Parallel Time light, 2-2

F

Failure to Synchronize light, 2-2
foundation, 1-1
frequency, generator, 2-2
functional test, 1-3, 1-4

H

harness, 1-2
 disconnect plugs, 2-1

I

inspection, 3-1
installation, 1-1
isolating the ATS, 3-2

L

lights, 1-3, 1-4
lubrication, 2-1

M

maintenance, preventive, 2-1
maintenance handle, 2-2
 warning, 2-2
manual load transfer, 2-2
 warning, 2-2

N

nameplate, cover
Normal Source Accepted light, 1-3

O

operation
 electrical, 1-4
 manual, 2-2
 warning, 2-2

P

parts, 2-1
phase rotation check, 1-3
preventive maintenance, 2-1
problem, 2-2

R

rating label, cover
removal of shipping angles, 1-1
removal of shipping skid, 1-1
replacement parts, 2-1
return to service, 3-3

S

service
 ASCO Services, Inc. (ASI), 2-1
settings
 see *Controller User's Guide*
shipping angles, 1-1
 warning, 1-1
shipping skid, 1-1

T

test, functional, 1-3, 1-4
testing power cables, 1-2
time delays, 2-1
 see *Controller User's Guide*
TS Locked Out light, 2-2
Transfer Control selector switch
 Retransfer Delay Bypass, 1-4
 Transfer Test, 1-4
Transfer Switch Connected To
 Emergency light, 1-4
Transfer Switch Connected To
 Normal light, 1-4
transfer test, 1-4, 2-1
transfer to emergency, 1-4, 2-1
transfer to normal, 1-4, 2-1
troubleshooting, 2-2

V

voltage checks, 1-3
voltage, pickup and dropout settings
 see *Controller User's Guide*