

# Operator's Manual

# ASCO® 7000 Series ACTB Automatic Closed-Transition Transfer & Bypass-Isolation Switches 3000 and 4000 amp sizes

## TABLE OF CONTENTS

	section-page
INSTALLATION .....	1-1
Mounting .....	1-1
Power Connections .....	1-2
Engine Starting & Auxiliary Circuits .....	1-2
Functional Test .....	1-5, 1-6, 1-7
TESTING & SERVICE .....	2-1
Transfer Test .....	2-1
Preventive Maintenance .....	2-1
Disconnecting the Control Panel .....	2-1
Manual Load Transfer .....	2-2
Trouble-Shooting .....	2-2
BYPASSING & ISOLATING .....	3-1
Bypassing the ATS .....	3-1
Isolating the ATS .....	3-1
Return to Service .....	3-3
INDEX .....	back cover

**Note:** Refer to the outline and wiring drawings provided with your 7000 Series ACTB for all installation and connection details and accessories.

**Note:** Refer to *Group 5 Control Panel User's Guide* 381333-126 for ATS status display messages, time delays, pickup & dropout settings, and adjustments.

### Rating Label

Each 7000 Series ACTB contains a rating label to define the loads and fault circuit withstand/closing ratings. Refer to the label on the Transfer Switch for specific values.

### **⚠ WARNING**

**Do not exceed the values on the rating label. Exceeding the rating can cause personal injury or serious equipment damage.**

### Nameplate

The Transfer Switch nameplate includes data for each specific 7000 Series 7ACTB. Use the switch only within the limits shown on this nameplate. A typical Catalog Number is shown below with its elements explained:

An experienced licensed electrician must install the ACTB.

### Catalog Number Identification

Typical 7000 Series ACTB catalog no. for overlapping neutral, 3 pole, 3000 amp, 480 V, in Type 1 enclosure:

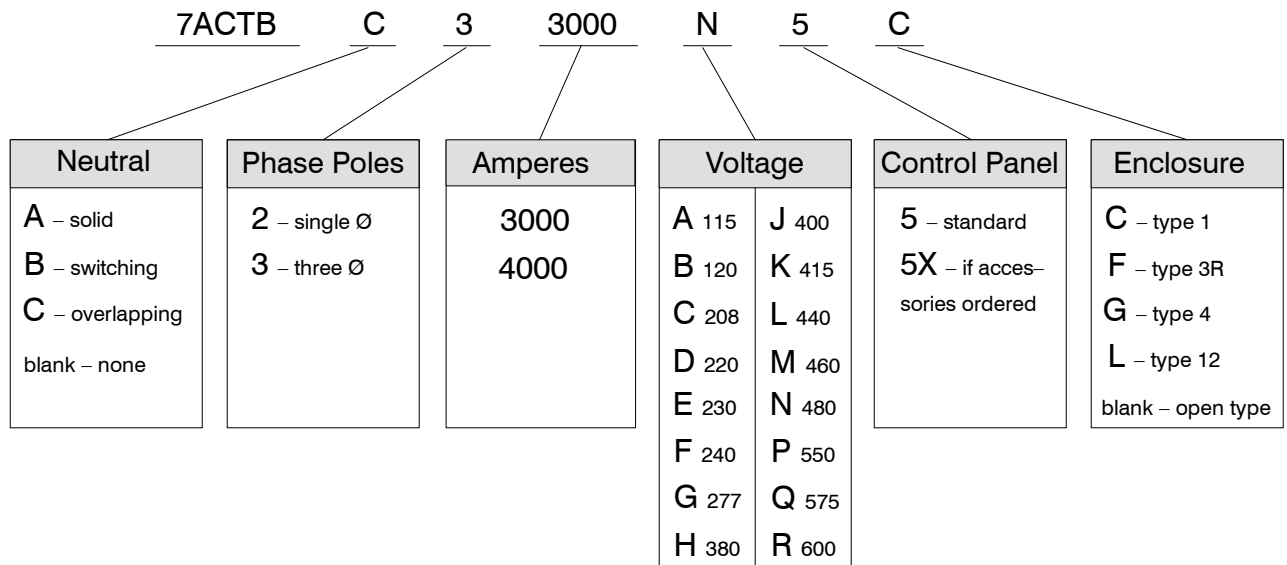

## SECTION 1 INSTALLATION

The ASCO 7000 Series Automatic Closed–Transition Transfer & Bypass–Isolation Switch (ACTB) consists of an upper bypass–isolation switch, a transfer switch, a monitoring and transfer control panel, and door–mounted controls. The ACTB is factory wired and tested. Installation requires removal of the shipping skid then securing the enclosure to the supporting foundation.

### Remove the Transfer Switch

The Transfer Switch is shipped inside the enclosure (ATS side) in the fully engaged position. Before installing the enclosure remove the Transfer Switch as follows:

1. Open the enclosure doors and install the two ramps (stored on right side).
2. Remove the Isolation Handle which is stored on the lower right front of the Transfer Switch carriage frame. Install the Isolation Handle onto the protruding shaft and turn it counterclockwise (approximately 10 turns) until it stops.
3. Unplug J2 and J5 harness plugs, and roll out the Transfer Switch. Cover it to keep it clean.

### Supporting Foundation

The supporting foundation and adjacent area must be level and straight, otherwise the Transfer Switch and enclosure may not align causing door problems. The floor under the enclosure must be flat and level. **This is very important!** The structure of the enclosure must be straight and square. Allow at least 36 inches for roll out of Transfer Switch. Refer to the enclosure drawing for required door opening space.

If bottom cable entry is used, the foundation must be prepared so that conduit stubs are located correctly. Refer to appropriate enclosure outline drawing for specified cable entrance area and location. Provide cable bending space and clearance to live metal parts. When a concrete floor is poured, use interlocking conduit spacer caps or a wood or metal template to maintain proper conduit alignment.

### Mounting

Refer to the enclosure outline drawing furnished with this switch and mount the 7000 Series ACTB according to the details and instructions shown on the drawing.

Bolt the cubicle sections together so that they are lined up on the front faces. See Figure 1–1.

#### DANGER

**De–energize the conductors before making any line or auxiliary circuitry connections. Be sure that Normal and Emergency line connections are in proper phase rotation. Place engine generator starting control in the OFF position. Make sure engine generator is not in operation.**

### Testing Power Conductors

Do not connect the power conductors to the ACTB until they are tested. Installing power cables in conduit, cable troughs, and ceiling-suspended hangers often requires considerable force. The pulling of cables can damage insulation and stretch or break the conductor's strands. For this reason, after the cables are pulled into position, and before they are connected they should be tested to verify that they are not defective or have been damaged during installation.

#### CAUTION

**Protect the switch from construction grit and metal chips to prevent malfunction or shortened life for the ACTB switch.**

# INSTALLATION (continued)

## Connecting Power Conductors

A *Wiring Diagram* is furnished with the ACTB. All wiring must be made in accordance with the local codes. After the power cables have been tested, connect them to the appropriate terminal lugs on the Bypass Switch as shown on the wiring diagram provided with this ACTB. Make sure that the lugs provided are suitable for use with the cables being installed. Standard terminal lugs are solderless screw type and will accept the wire sizes listed on the drawings provided with the ACTB. Be careful when stripping insulation from conductors; avoid nicking or ringing the conductor. Remove surface oxides from conductors by cleaning with a wire brush. Follow conductor manufacturer's instructions when aluminum conductor is used. Apply joint compound to conductor, then carefully wipe away excess compound. Tighten the cable lugs to the torque specified on the rating label.

### ⚠ CAUTION

Be sure that the Normal and Emergency power connections are in proper phase rotation.

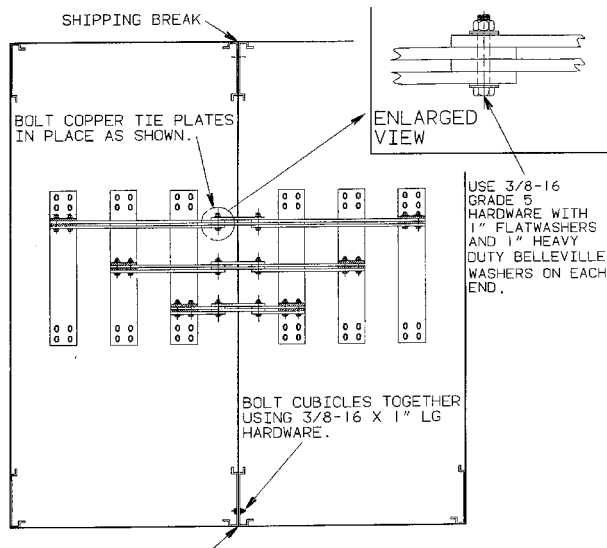

NOTE: -FRONT EDGE OF CUBICLES MUST BE IN LINE.  
 - UNITS ARE SHIPPED SEPERATELY FOR CONVENIENCE IN HANDLING.  
 - COPPER TIE BUS PLATES ARE SHIPPED WITH JOB LOOSE.

Figure 1-1. Bus tie plates (top view).

### ⚠ CAUTION

See job specific drawings supplied with ACTB.

## Bus Connections

If bus connection is used, use SAE grade 5 hardware to connect bus to appropriate terminal plates on bypass switching device. Wipe off bus surfaces before they are joined. If bus is dirty, gently clean surfaces with a non-flammable solvent. Avoid touching cleaned surfaces.

### ⚠ CAUTION

Do not breathe cleaning solvent vapors.

Use SAE grade 5 hardware and tighten the bolted joints to the torque specified in Table 2-1.

### ⚠ CAUTION

The reliability of the connection depends on how clean and how tight the joint is.

Table 2-1. Tightening torque values for bolted joints.

Bolt Diameter (Grade 5 hardware) in inches	Recommended Tightening Torque in foot pounds
5/16	12
3/8	20
1/2	50
5/8	95
3/4	155

## Harnesses

All internal connections are made at the factory. The bypass switch, transfer switch, and control panel are joined together by an interconnecting wire harness. The disconnect plugs are already engaged on enclosed switches. For opentype switches, the plugs must be engaged after installation is completed. Align harness plugs with sockets in the control and push them together until they are secure.

## Engine Starting Contacts and Auxiliary Circuits

The engine control contact signal connections and auxiliary circuits are located on terminal block TB as shown on the *Wiring Diagram* provided with the ACTB. Connect the signal wires to the appropriate terminals.

## INSTALLATION (continued)

### Install the Transfer Switch

After the enclosure is installed and power cables or bus connected to the Bypass Switch, the Transfer Switch carriage can be rolled in. The floor of the cabinet must be free of debris and clean. If necessary, use a vacuum cleaner. Make a thorough inspection to be sure no tools are left inside. The Bypass Handle must be in the *BYPASS POS* position (closed on normal). The Isolation Handle (draw-out crank) must be fully counterclockwise against stop.

#### **⚠ DANGER**

**Do not apply any electrical power to the ATB yet.**

It is not necessary to remove the barriers from the bypass switch and transfer switch. If you do remove them, however, reinstall them carefully.

**NOTE:** Be sure to roll the correct Transfer Switch into the enclosure. If more than one is supplied, each will be labeled above the solenoid operator.

The Transfer Switch *NORMAL* contacts must be closed. If not, use the manual operator handle (maintenance handle stored on lower carriage) to manually operate the switch. See Figure 1-10. Check that all arc chutes and interphase barriers are in place on the Transfer Switch. Then grasp the Transfer Switch carriage frame and roll it into the cabinet (isolation contacts facing inward). Align the rollers between the floor guides and push the carriage in until its crank pins engage the latch plates on both sides. Then follow the procedure below:

**NOTE:** Solenoid lock *SL1* on the Isolation shaft inhibits operation of the drawout (Isolation contacts) unless the Transfer Switch and Bypass Switch are in compatible positions. This solenoid must energize to unlock. Because all power sources are de-energized, the interference tag defeats the solenoid in the following inspections.

Do the three inspections on page 1-4 without any electrical power connected. The inspections will verify that the isolation contacts are in proper alignment. If necessary, add shims under the floor. It may be helpful to remove the the right side of the enclosure to expose the isolation contacts during the inspections.

#### **■ WARNING**

**Do not apply any power to the Bypass Switch. Be sure that the Normal and Emergency source circuit breakers are OPEN before proceeding.**

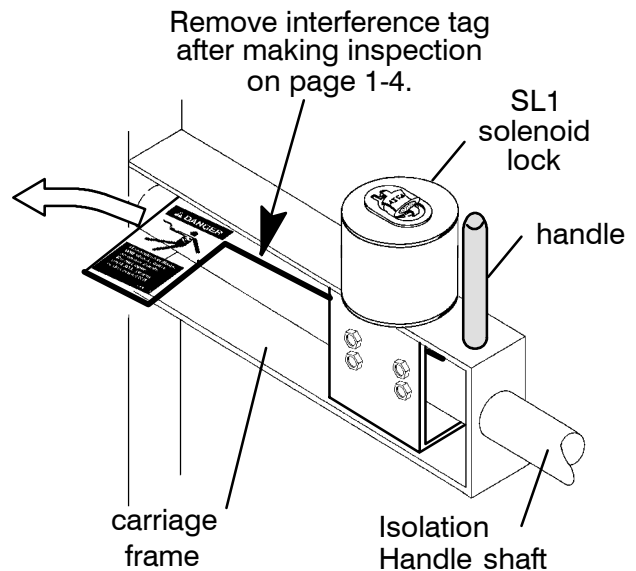

Figure 1-2. Solenoid latch interference tag.

#### **ISOLATION HANDLE**

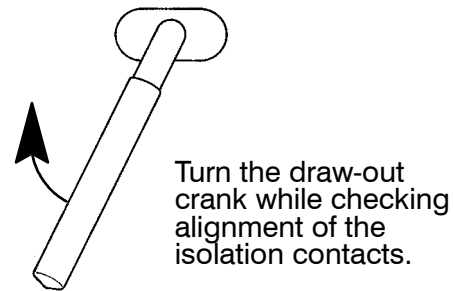
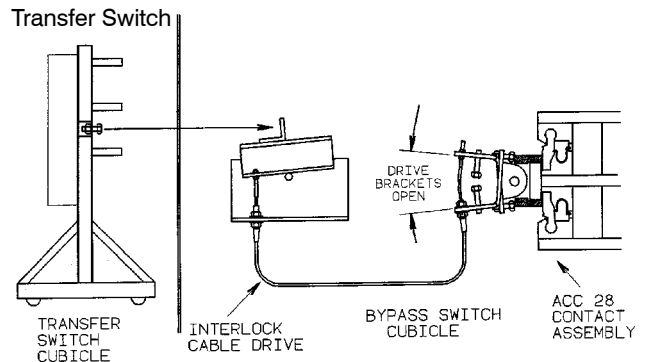

Figure 1-3. Isolation Handle.



#### DESCRIPTION-

-THIS INTERLOCK DISCONNECTS THE BYPASS SWITCH ACC 28 WHEN THE TRANSFER SWITCH IS ENGAGED AND CONNECTS THE BYPASS SWITCH ACC 28 WHEN THE TRANSFER SWITCH IS WITHDRAWN.

-NO CUSTOMER ADJUSTMENTS ARE NORMALLY REQUIRED OTHER THAN TO MAKE SURE THE (2) CUBICLES ARE LINED UP FLUSH ON THE FRONT FACES AND VERIFYING THAT THE ACC 28 CABLE DRIVE OPERATES THE BYPASS SWITCH CONTACTS TO OPEN AS THE TRANSFER SWITCH IS "CRANKED IN". NOMINAL CONTACT GAP 1/8" WHEN OPEN.

Figure 1-4. Switched neutral interlock.

# INSTALLATION *(continued)*

## Inspection 1

### ⚠ CAUTION

Do not force the Isolation Handle. Be sure that the isolation contacts do not touch the male stabs.

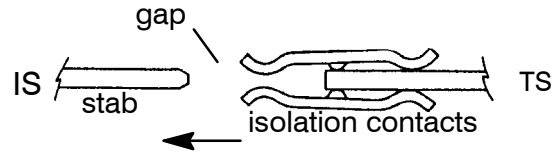

Figure 1-5. Isolation contacts in TEST position.

### Move ATS from DISCONNECTED To TEST Position *(without electrical power)*

Action	Turn the Isolation Handle (Figure 1-3) clockwise approximately 7 or 8 turns.
Observe	The Transfer Switch should be pulled inward; the isolation contact fingers should <u>not</u> make with the male stabs as shown in Figure 1-5.

## Inspection 2

### ⚠ CAUTION

Do not force the Isolation Handle. Be sure that the isolation contact fingers make with the male stabs on both sides in the CONNECTED position.

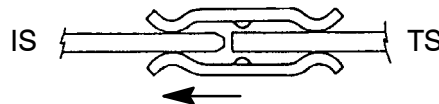

Figure 1-6. Isolation contacts CONNECTED (CLOSED).

### Move ATS From TEST To CONNECTED Position *(without electrical power)*

Action	With solenoid latch interference tag in place (Figure 1-2), continue slowly turning the Isolation Handle clockwise until it stops (approximately 6 or 7 turns). <b>Now remove the interference tag from the solenoid latch.</b>
Observe	The Transfer Switch should be pulled inward; the isolation contact fingers should make with the male stabs as shown in Figure 1-6. Also check that the Bypass Switch switched neutral contacts have opened (Figure 1-4).

## Inspection 3

### ⚠ WARNING

Be sure that the isolation contacts disconnect in the TEST position.

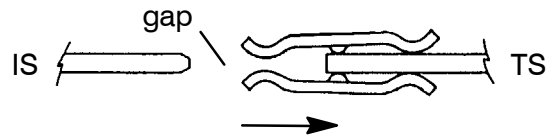

Figure 1-7. Isolation contacts back in TEST position.

### Move ATS From CONNECTED Back To TEST Position *(without electrical power)*

Action	Turn the Isolation Handle (Figure 1-3) back counterclockwise until the isolation contacts separate (approximately 6 or 7 turns).
Observe	The Transfer Switch should be pushed outward; the isolation contacts should disconnect as shown in Figure 1-7.

If all inspections are satisfactory connect harness plugs J2 and J5. Proceed to the Function Test.

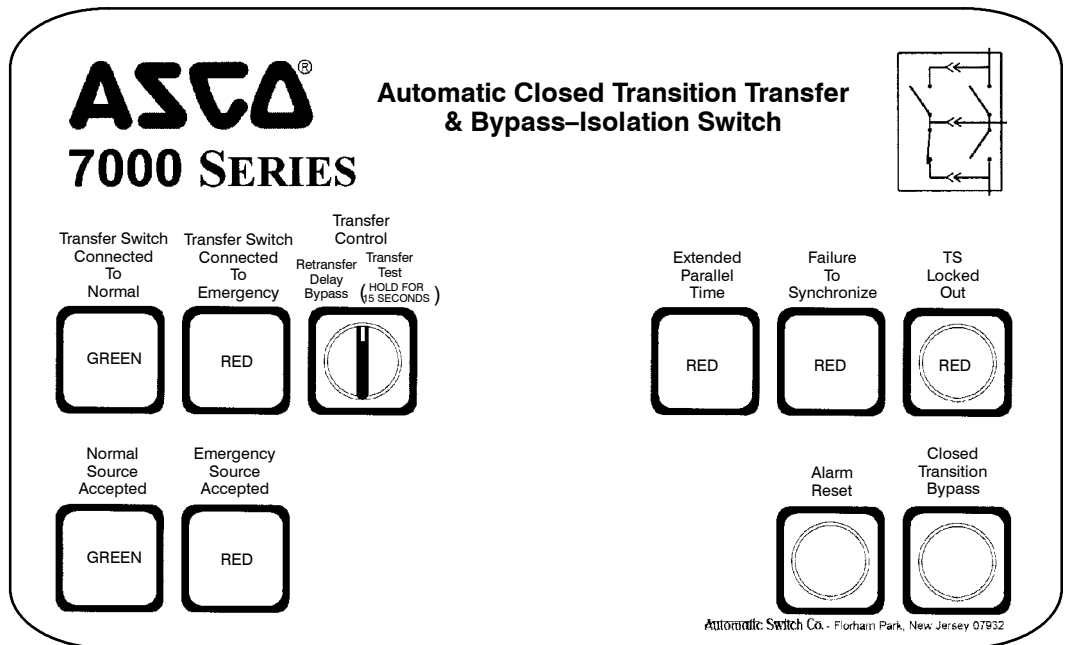

Figure 1-8. Standard controls and indicators.

### Functional Test

Read all instructions on the *Wiring Diagrams* and labels affixed to the ACTB. Note the control features that are provided and review their operation before proceeding.

After installing the ACTB check the following:

- Bypass Handle should be in the *BYPASS POS* position (closed on normal)
- Isolation contacts should be in the *TEST* position (see pages 1-3 and 1-4).
- CN transfer switch should be in *C* (closed) position
- CE transfer switch should be in *O* (open) position

If handles are not in correct positions, follow instructions for Bypassing and Isolating the automatic transfer switch in **Section 3**. **Do not force the handles.** Electrical interlocks prevent a wrong sequence of operation.

### 1 – Voltage Checks

First check nameplate on transfer switch; rated voltage must be the same as normal and emergency line voltages.

**■ DANGER**

**Use extreme caution when using a meter to measure voltages. Do not touch power terminals; shock, burns, or death could result !**

Perform steps 1–6 at the right. Observe the status lights. See Figures 1–8 and 1–11.

- Black square means light is on.
- White square means light is off.

\* If necessary, adjust voltage regulator on generator per the manufacturer’s recommendations. The ACTB will respond only to rated voltage specified on the nameplate.

Now continue to **2 – Manual Operation Test**, next page.

1	Close the normal source circuit breaker. The <i>Transfer Switch Connected To Normal</i> and the <i>Normal Source Accepted</i> lights should come on.	
2	Use an accurate voltmeter to check phase to phase and phase to neutral voltages present at the transfer switch normal source terminals.	
3	Close the emergency source circuit breaker. (Start generator, if necessary.) The <i>Transfer Switch Connected To Normal &amp; Emergency Source Accepted</i> lights should come on.	
4	Use an accurate voltmeter to check phase to phase and phase to neutral voltages present at the transfer switch emergency source terminals.*	
5	Use a phase rotation meter to check phase rotation of emergency source; it must be the <u>same</u> as the normal source.	
6	Shut down the engine-generator, if applicable. The <i>Emergency Source Accepted</i> light should go off. Then put the starting control selector switch (on the generator set) in the <i>automatic</i> position. Close enclosure door.	

# INSTALLATION (continued)

## 2 – Manual Operation Test

This procedure will check the manual operation of the Bypass Switch, Isolation Switch, and Transfer Switch. Observe the lights on the Status Indicator panel. The Bypass Switch *CLOSED ON NORMAL* and the *TEST* lights should be on. See Figure 1–11.

1. Isolate the Automatic Transfer Switch:

Install the Isolation Handle and turn it counterclockwise until it stops (approximately 7 or 8 turns). The Automatic Transfer Switch is now in the Disconnected position. (See Figure 1–9.) The *DISCONNECTED* light should come on.

### ISOLATION HANDLE

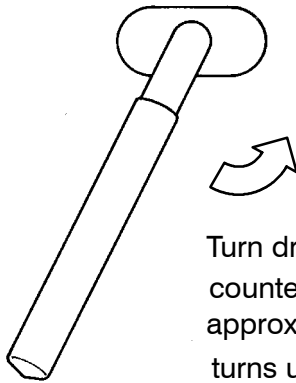

Turn draw-out crank counterclockwise approximately 7 or 8 turns until it stops.

Figure 1–9. Open (disconnect) isolation contacts.

2. A detachable manual operator handle is provided on the Transfer Switches for maintenance purposes only. Manual operation of both CN and CE transfer switches must be checked before they are operated electrically.

**⚠ WARNING**

**Do not manually operate the Transfer Switch unless the Isolation Handle is in the *OPEN* position and the *DISCONNECTED* light is on.**

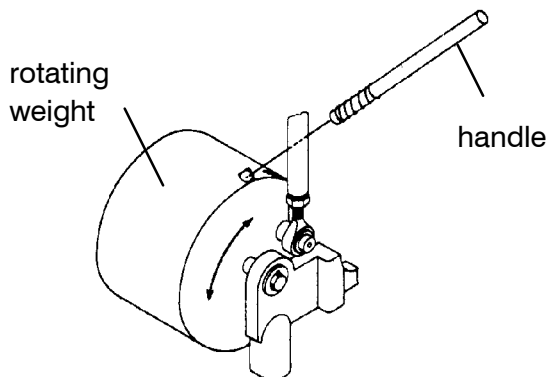

Figure 1–10. Transfer Switch manual operator handle.

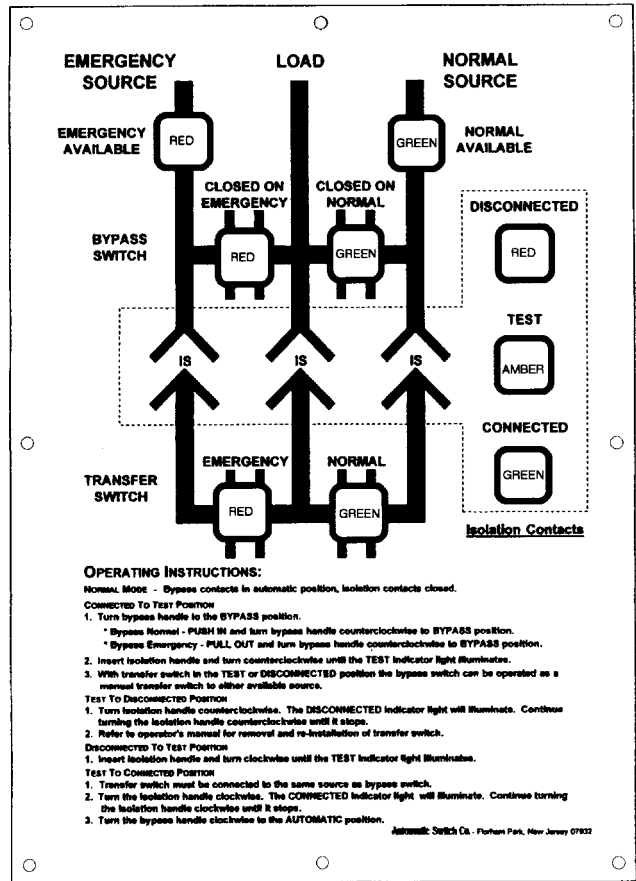
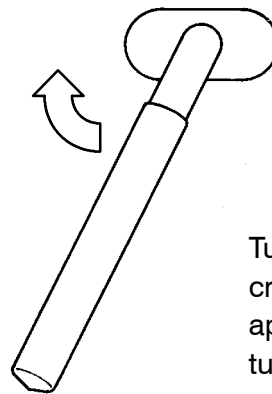

Figure 1–11. Status Indicator Panel.

Insert manual handle into hole in rotating weight as shown in Figure 1–10. Move installed handle up and down to manually operate Transfer Switch. It should operate smoothly without binding. Repeat manual operation check on other Transfer Switch. Return the CN Transfer Switch to *C* (closed) position; return CE Transfer Switch to *O* (open) position. Remove manual operator handle and store it on Transfer Switch in place provided. Now go to page 1–7.

### ISOLATION HANDLE



Turn draw-out crank clockwise approximately 7 or 8 turns until TEST light comes on.

Figure 1–12. Move ATS to TEST position.

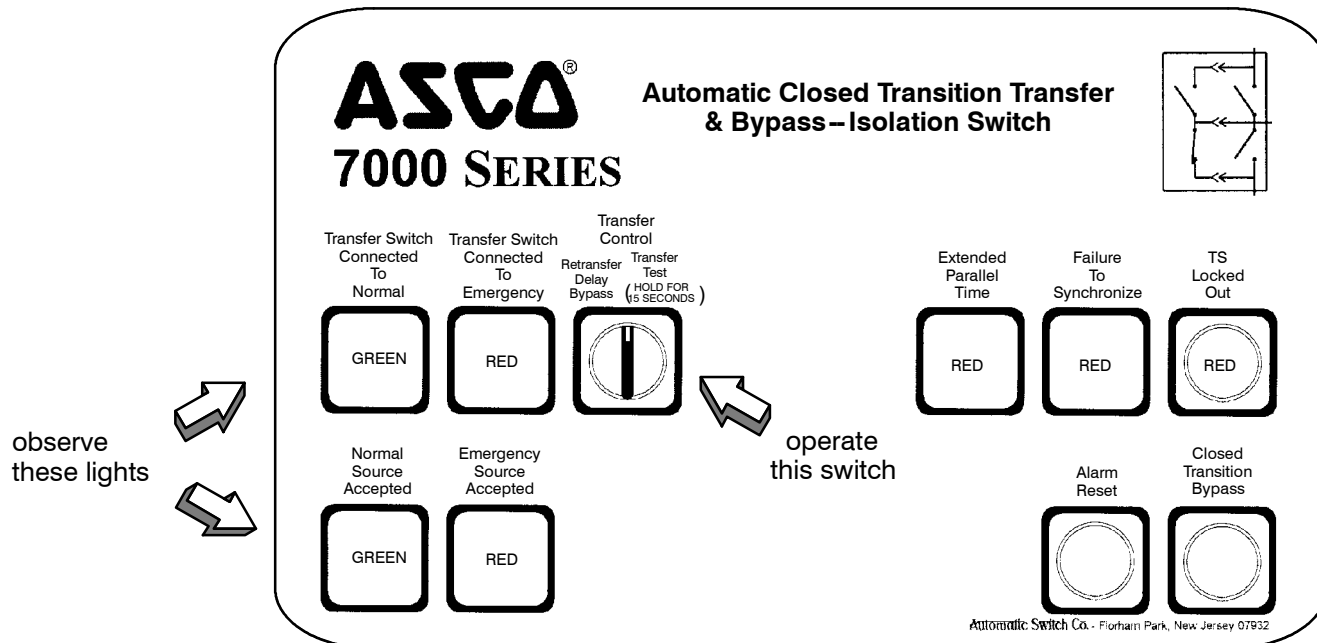

Figure 1-13. Standard controls and indicators.

### 3 – Electrical Operation

This procedure checks electrical operation of the ATS.

**⚠ WARNING**

**Be sure to close all enclosure doors before proceeding to prevent personal injury in case of electrical system fault.**

#### Transfer Test

The ATS should still be bypassed and isolated. Both normal and emergency sources must be available and the emergency source generator (if used) must be capable of being started; put engine starting control in *automatic* position. The *Transfer Switch Connected to Normal* light and the *Normal Source Accepted* light should be on.

1. Turn **Isolation Handle** clockwise about 7–8 turns until *TEST* light comes on, *DISCONNECTED* light off.
2. Perform steps 1–5 at right. Observe the status lights.
  - Black square means light is on.
  - White square means light is off.
3. Turn the **Isolation Handle** clockwise until it stops (about 6 or 7 turns). The *CONNECTED* light should come on, *TEST* light off. Remove the Isolation Handle and store it inside the enclosure on the carriage frame on the right side.
4. Turn the **Bypass Handle** clockwise to the *AUTOMATIC POS* position. The Bypass Switch *CLOSED ON NORMAL* light should go off.

This completes the Functional Test of the ACTB. The generator’s starting control should be left in *automatic* position.

1	The <i>Transfer Switch Connected to Normal</i> and <i>Normal Source Accepted</i> lights should be on.	
2	Turn and <u>hold</u> <b>Transfer Control</b> switch clockwise to <i>Transfer Test</i> until the engine starts and runs (within 15 sec.). The <i>Emergency Source Accepted</i> light should come on.	
3	Transfer switch CE closes and then Transfer Switch CN opens (closed–transition overlap). The <i>Transfer Switch Connected To Emergency</i> light comes on and <i>Transfer Switch Connected to Normal</i> light goes off (you might see and hear the brief overlap).	
4	Transfer switch will operate back to Normal position after Feature 3A time delay. For immediate retransfer turn <b>Transfer Control</b> counterclockwise to <i>Retransfer Delay Bypass</i> . The <i>Transfer Switch Connected To Normal</i> light should come on; <i>Transfer Switch Connected to Emergency</i> light should go off.	
5	The engine–generator will stop after the Feature 2E time delay (unloaded running engine cool-down). The <i>Emergency Source Accepted</i> light should go off.	

## SECTION 2 TESTING & SERVICE

### TRANSFER TEST

Test the Automatic Transfer Switch portion of the 7000 Series ACTB at least once a month. This procedure checks the electrical operation of the Transfer Switch and Control Panel. Put the engine-generator starting control (at the engine-generator set) in automatic mode.

In the following test the generator will start, the load will be transferred to the Emergency source, then back to the Normal source. An interruption to the load will occur, unless the the Transfer Switch contacts are bypassed before the test. See page 3-1 for bypassing & isolating instructions if no interruption of load is required.

#### **WARNING**

**Be sure to close the enclosure door before proceeding to prevent personal injury in case of electrical system fault.**

Perform the five-step **Electrical Operation – Transfer Test** procedure on page 1-7.

### PREVENTIVE MAINTENANCE

Reasonable care in preventive maintenance will insure high reliability and long life for the 7000 Series ACTB. An annual preventive maintenance program is recommended.

ASCO Services, Inc. (ASI) is Automatic Switch Company's national service organization. ASI can be contacted at 973-966-2070 for information on preventive maintenance agreements.

### Checklist for Yearly Inspection

#### **DANGER**

**Hazardous voltage capable of causing shock, burns, or death is used in this switch. Deenergize both Normal – Emergency power sources before performing inspections!**

- Clean the ATS enclosure.** Brush and vacuum away any excessive dust accumulation. Remove any moisture with a clean cloth.
- Check the transfer switch contacts.** Remove transfer switch barriers and check the condition of the contacts. Replace contacts when pitted or worn excessively. Reinstall the barriers carefully.
- Maintain transfer switch lubrication.** If switch is subjected to severe dust or abnormal operating conditions, renew factory lubrication on all movements and linkages. Relubricate solenoid operator if TS coil is replaced. Don't use oil; order *lubrication kit 75-100*.
- Check all cable connections & retighten them.**

### REPLACEMENT PARTS

Replacement parts are available in kit form. When ordering parts provide the Serial No., Bill of Material No. (BOM), and Catalog No. from the transfer switch nameplate. Contact your local ASCO Sales Office or ASI:

call 1-800-800-ASCO

### DISCONNECTING THE CONTROL PANEL

The harness disconnect plugs are furnished for repair purposes only and should not have to be unplugged. If the control panel must be isolated, follow these steps:

#### **DANGER**

**Bypass-Isolation Switch is energized! Do not touch isolation contact fingers; shock, burns, or death could result!**

### Disconnecting the Plugs

1. Bypass and Isolate the Automatic Transfer Switch.
2. Open the upper enclosure door.
3. Separate the two quick disconnect plugs by squeezing the latches. Do not pull on the harness wires.

### Reconnecting the Plugs

1. The ATS should be still bypassed and isolated.
2. The two harness plugs and sockets are keyed. Carefully align the plugs with the sockets and press straight in until the latches click.
3. Close the enclosure doors.
4. Follow *Return to Service* instructions on page 3-3.

# TESTING & SERVICE *(continued)*

## TROUBLE-SHOOTING

Note any optional accessories that may be furnished on the ACTB and review their operation. Refer to any separate drawings and/or instructions that may be packed with the ACTB.

**⚠ DANGER**

**Hazardous voltage capable of causing shock, burns, or death is used in this switch. Do not touch the power or load terminals of the switch!**

Table 2-1. Trouble-Shooting Checks.

PROBLEM	CHECK IN NUMERICAL SEQUENCE		
	1 OPERATION	2 GEN-SET	3 VOLTAGE
Engine-generator set does not start when the <b>Transfer Control</b> switch is turned and held in <i>Transfer Test</i> position or when normal source fails.	Hold <i>Transfer Test</i> switch 15 seconds or the outage must be long enough to allow for Feature 1C time delay plus engine cranking and starting.	Starting control must be in the automatic position. Batteries must be charged and connected. Check wiring to engine starting contacts.	-
Transfer switch does not transfer the load to the emergency source after the engine-generator set starts.	Wait for Feature 2B time delay to time out.	Generator output circuit breaker must be closed. Generator frequency must be at least 95% of nominal (57 Hz for a 60 Hz system.) *	Voltmeter should read at least 90% of nominal phase to phase voltage between terminals EA and EC (or EL1 and EL2 for 2 pole switches)*
Transfer switch does not transfer the load to normal source when normal returns or when the <b>Transfer Control</b> switch is released.	Wait for Feature 3A time delay to time out.	-	Voltmeter should read at least 90% of nominal phase to phase voltage between terminals NB and NC, NC and NA, and NA and NB (or NL1 and NL2 for 2 pole switches).
Gen. does not stop after load retransfer to normal source.	Wait for Feature 2E time delay to time out.	Starting control must be in the automatic position.	-
<i>Failure to Synchronize</i> light comes on.	Conditions of Normal or Emergency Sources not suitable for closed transition transfer. Recheck voltage and frequency of both sources. Press <b>Alarm Reset</b> pushbutton.		
<i>Extended Parallel Time</i> light comes on.	CN and CE contacts are closed longer than setting in the Control Panel. Open the disconnected source circuit breaker, then call your nearest ASCO Service Center for assistance.		
<i>TS Locked Out</i> light comes on.	Transfer lockout operation has occurred; transfer switch is disabled from automatic operation. Open the disconnected source circuit breaker, then call your nearest ASI for assistance.		

\* These are factory settings. Refer to **Control Panel User's Guide**.

If the problem is isolated to circuits on the control panel or the transfer switch, call your local Automatic Switch Company sales office. Furnish the Serial No. and Catalog No. from the transfer switch nameplate.

## MANUAL LOAD TRANSFER

This procedure manually transfers load to other source if the Transfer Switch or Control Panel are out of service.

**⚠ WARNING**

**Close all enclosure doors to prevent personal injury in case of electrical system fault.**

1. Be sure that the Bypass Handle is in the *BYPASS POS* (position) (see page 3-1).
2. Be sure that the Isolation Handle is in the *TEST* or *DISCONNECTED* position (see page 3-2).
3. Turn the Bypass Handle clockwise to *AUTOMATIC POS* (position).

4. Then pull-out or push-in the Bypass Handle and turn it back to *BYPASS POS* (select opposite source):
  - Emergency Source - pull out the handle
  - Normal Source - push in the handle

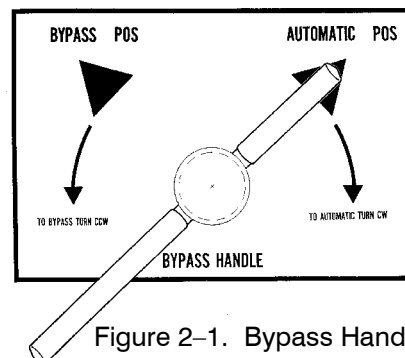

Figure 2-1. Bypass Handle.

# SECTION 3 BYPASSING & ISOLATING

## BYPASSING

This procedure explains how to Bypass the closed Automatic Transfer Switch contacts. Bypassing is required before the ATS can be tested or isolated. The Bypass Switch must be in the *AUTOMATIC POS* (position) and the Isolation Handle must be in the connected position (turned clockwise until it stops). The *CONNECTED* light should be on.

1. Observe which Automatic Transfer Switch *CLOSED ON* light is on (*NORMAL* or *EMERGENCY*) on the STATUS INDICATOR panel. This light indicates the source connected to the load.
2. Bypass to the **same** source connected to the load as follows (select direction). See Figure 3-1, Figure 3-2, and Figure 3-3.

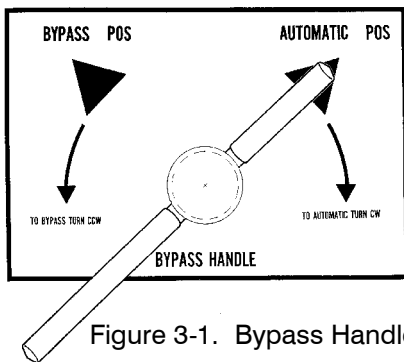

Figure 3-1. Bypass Handle.

### To Bypass Normal Source

**Push in** the Bypass Handle then turn it counterclockwise to *BYPASS POS*. The Bypass Switch *CLOSED ON NORMAL* light should come on. \*

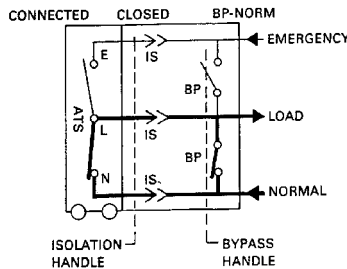

Figure 3-2. Bypass to Normal.

### To Bypass Emergency Source

**Pull out** the Bypass Handle then turn it counterclockwise to *BYPASS POS*. The Bypass Switch *CLOSED ON EMERGENCY* light should come on. \*

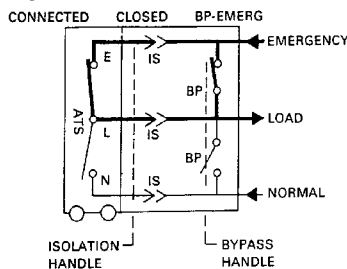

Figure 3-3. Bypass to Emergency.

The Automatic Transfer Switch can now be put in the *TEST* or *OPEN* position. See **ISOLATING**.

\* **NOTE:** When Acc. 66A is specified, the handle operation is reversed. Follow instruction on the door.

## ISOLATING

This procedure explains how to isolate the Automatic Transfer Switch. Isolating is required before any service work can be performed on the ATS. Observe the ATS *POSITION* lights on the STATUS INDICATOR panel.

1. Bypass the closed Automatic Transfer Switch contacts. See **BYPASSING**.
2. Isolate the Automatic Transfer Switch as follows. Refer to Figure 3-4 and Figure 3-5.

### ISOLATION HANDLE

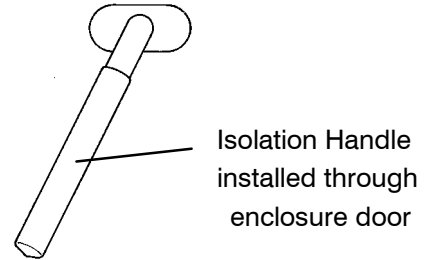

Figure 3-4. Isolation Handle.

### ⚠ DANGER

**Bypass-Isolation Switch is energized. Do not touch isolation contact fingers; shock, burns, or death could result.**

### To Isolate the Automatic Transfer Switch

- a. Open the enclosure door and remove the **Isolation Handle** stored on the right side of the carriage frame. Close the door. Insert the Isolation Handle into the shaft (through the door).
- b. Turn **Isolation Handle** counterclockwise (about 6 or 7 turns) until the *TEST* light comes on.
- c. Continue turning **Isolation Handle** counterclockwise (approximately 10 or 11 turns) until it stops and *DISCONNECTED* light comes on, *TEST* light off.
- d. Remove **Isolation Handle** and store it inside the enclosure on the right side of the carriage frame.

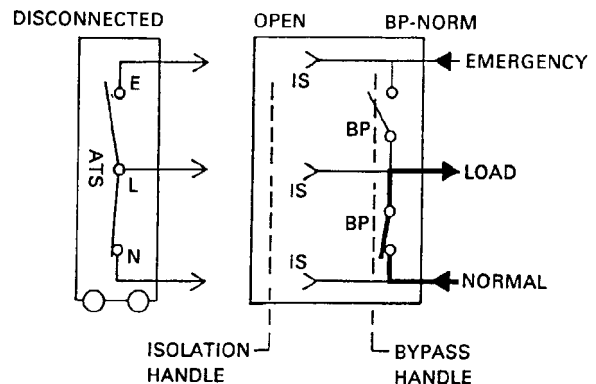

Figure 3-5. Isolated (DISCONNECTED) ATS.

The Transfer Switch can now be removed for inspection and maintenance. See page 3-2.

## BYPASSING & ISOLATING (continued)

### TRANSFER SWITCH REMOVAL

This procedure explains how to remove the Transfer Switch for inspection and maintenance.

1. Bypass and Isolate the Automatic Transfer Switch by carefully following directions on page 3-1. Be sure that the *ATS POSITION DISCONNECTED* light is on. Then remove the Isolation Handle.

#### **⚠ DANGER**

**Hazardous voltage capable of causing electrical shock, burns, or death.  
Do not touch isolation contact fingers.**

2. Open the ATS cabinet doors all the way. Remove the bottom louvered enclosure pan.
3. Separate the in-line disconnect plugs (P2 and P5) by grasping and squeezing the plugs. Do not pull on the harness wires.
4. Remove the Transfer Switch from the enclosure:

The enclosure tracks and floor in front must be free of debris. Grasp the Transfer Switch carriage frame and roll it out of the enclosure. See Figure 3-6.

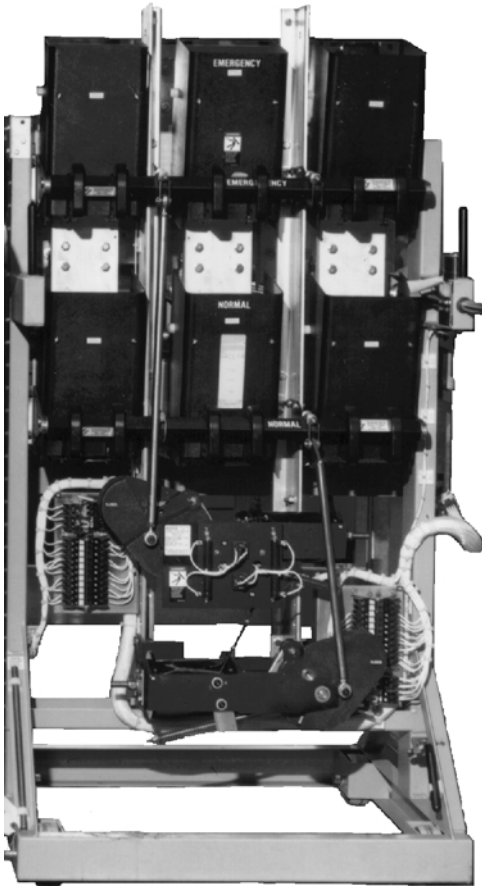

Figure 3-6 Transfer Switch removed.

5. Close the cabinet doors.

### TRANSFER SWITCH REINSTALLATION

This procedure explains how to install the Transfer Switch after inspection and maintenance.

#### **⚠ DANGER**

**Hazardous voltage capable of causing electrical shock, burns, or death.  
Do not touch isolation contact fingers.**

1. Open the ATS cabinet doors all the way. Remove the bottom louvered enclosure pan (if not already removed).

#### **⚠ CAUTION**

**All arc chutes and interphase barriers must be in place on the Transfer Switch. The enclosure tracks and floor in front must be free of debris.**

#### **⚠ CAUTION**

**The Transfer Switch contacts must be closed on the same source that is feeding the load (use the maintenance handle – see page 1-6).**

**NOTE:** Be sure to install the correct Transfer Switch into the enclosure. If more than one is supplied, each will be labeled.

2. Install the Transfer Switch into the enclosure:

Grasp the Transfer Switch carriage frame and roll it into the enclosure (isolation contacts facing inward). Align the rollers between the floor guides and push the carriage in until its crank pins engage the latch plates on both sides.

3. Reconnect the in-line disconnect plugs by grasping and pressing them together. Be sure to connect the correct plugs.
4. Close the cabinet door and install the enclosure pan.
5. Install the Isolation Handle. Carefully follow directions on page 3-3 to put the Isolation Handle in the *TEST* position, then the *CLOSED* position. Finally, follow directions on page 3-3 to put the Bypass Handle in the *AUTOMATIC POS* (position).

# BYPASSING & ISOLATING (continued)

## RETURN TO SERVICE

This procedure explains how to return the Automatic Transfer Switch to service after inspection and maintenance. Observe the ATS POSITION lights on the STATUS INDICATOR panel.

1. Install the Transfer Switch into the enclosure. Carefully follow directions on page 3-2.

### **WARNING**

**Close enclosure door to prevent personal injury in case of electrical system fault.**

- 2.. Install the Isolation Handle (through the door) and turn it clockwise (approximately 7 or 8 turns) until the *TEST* light comes on, *DISCONNECTED* light off.

**NOTE:** If the emergency source is available, the Automatic Transfer Switch may operate to the emergency position. If it does, operate the door-mounted *RESET TO NORMAL* toggle switch.

**Electrical Operation Test:** This procedure will check the electrical operation of the Automatic Transfer Switch without interrupting the load. It still should be Bypassed and in the *TEST* position. The engine starting control should be in the *automatic* position.

### Transfer Test

Perform the 5-step *Transfer Test* procedure on page 1-7.

The isolating contacts cannot be closed until the Transfer Switch is in the **same** position as the Bypass Switch.

3. Observe which Bypass Switch *CLOSED ON* light is on (*NORMAL* or *EMERGENCY*) on the *STATUS INDICATOR* panel as shown in Figure 3-7. This light indicates the source connected to the load.
4. Observe which Transfer Switch *CLOSED ON* light is on (*NORMAL* or *EMERGENCY*). This light indicates the position of the Transfer Switch. If it is not in the same position as the Bypass Switch, change the Transfer Switch position as follows.

### To change the position of transfer switch

Operate to NORMAL	Operate to EMERGENCY
Turn <b>Transfer Control</b> switch counterclockwise to <i>Retransfer Delay Bypass</i> .	Turn <b>Transfer Control</b> switch clockwise to <i>Transfer Test</i> and <u>hold</u> .*
<i>Transfer Switch Connected to Normal</i> light should come on.	<i>Transfer Switch Connected to Emergency</i> light should come on.

\* If Feature 2B time delay is used, there will be a delay before transfer to Emergency.

**NOTE:** With Normal available, the Automatic Transfer Switch will not stay in the emergency position unless Feature 3A time delay is used (at least 30 seconds).

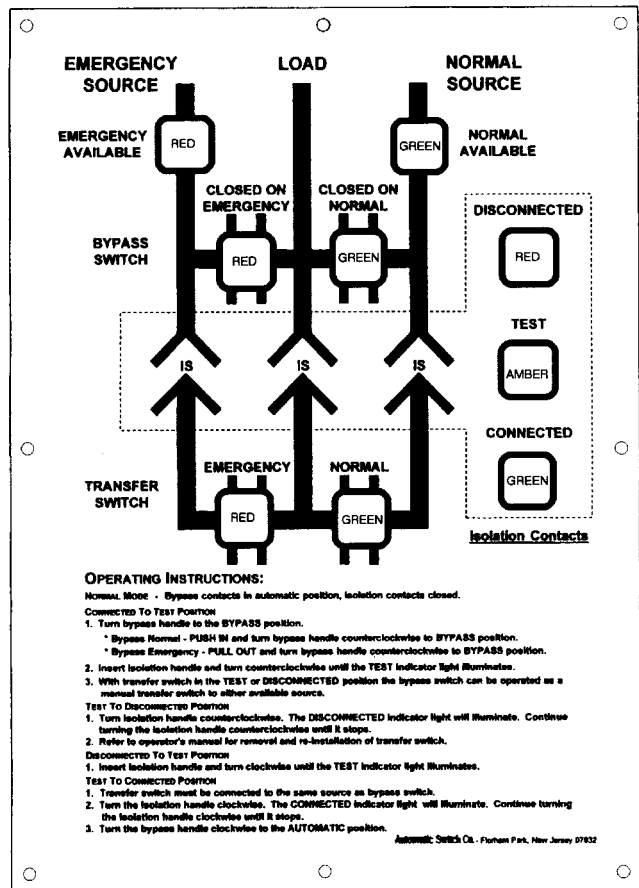

Figure 3-7 . Status Indicator Panel

### **WARNING**

**Do not close the isolating contacts unless the transfer switch and bypass switch are in the same position.**

5. Turn the Isolation Handle and turn it clockwise until it stops (approximately 6 or 7 turns). The *CONNECTED* light should come on, *TEST* light off.
6. Remove the Isolation Handle and store it inside the enclosure on the right side.
7. Turn Bypass Handle clockwise as shown in Figure 3-8 to *AUTOMATIC POS*. The Bypass Switch *CLOSED ON NORMAL* or *EMERGENCY* light should go off.

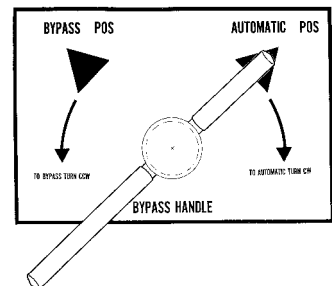

Figure 3-8 Turn Bypass Handle to AUTOMATIC.

The Automatic Closed-Transition Transfer & Bypass Isolation Switch should be left in this position.

# INDEX

## A

Alarm Reset pushbutton, 1-7, 2-2  
auxiliary circuits, 1-2

## B

bus connections, 1-2  
bypassing the ATS, 3-1

## C

catalog number, cover  
cleaning, 2-1  
closed-transition transfer, 1-7  
connections  
  power, 1-2  
control panel  
  disconnecting, 2-1  
  see *Control Panel User's Guide*

## E

electrical operation, 1-7  
Emergency Source Accepted light,  
  1-5  
engine starting contacts, 1-2  
*Extended Parallel Time* light, 2-2

## F

*Failure to Synchronize* light, 2-2  
frequency, generator, 2-2  
functional test, 1-5, 1-6, 1-7

## H

harness, 1-2  
  disconnect plugs, 2-1

## I

inspection, 1-4, 3-1  
installation, 1-1, 1-3  
isolating the ATS, 3-1

## L

lights, 1-5, 1-6  
load connected to emergency, 1-5  
load connected to normal, 1-5  
lubrication, 2-1

## M

maintenance, preventive, 2-1  
maintenance handle, 2-2  
  warning, 2-2  
manual load transfer, 2-2  
  warning, 2-2

## N

nameplate, cover  
Normal Source Accepted light, 1-5

## O

operation  
  electrical, 1-7  
  manual, 1-6  
  warning, 1-6

## P

parts, 2-1  
phase rotation check, 1-2  
preventive maintenance, 2-1  
problem, 2-2

## R

rating label, cover  
replacement parts, 2-1  
return to service, 3-3

## S

service  
  ASCO Services, Inc. (ASI), 2-1  
settings  
  see *Control Panel User's Guide*

## T

test, functional, 1-5, 1-6, 1-7  
testing power cables, 1-1  
time delays, 2-1  
  see *Control Panel User's Guide*  
Transfer Control selector switch  
  Retransfer Delay Bypass, 1-7  
  Transfer Test, 1-7  
Transfer Switch Connected To  
  Emergency light, 1-7  
Transfer Switch Connected To  
  Normal light, 1-7  
transfer test, 1-7, 2-1  
transfer to emergency, 1-7, 2-1  
transfer to normal, 1-7, 2-1  
troubleshooting, 2-2  
*TS Locked Out* light, 2-2

## V

voltage checks, 1-5  
voltage, pickup and dropout settings  
  see *Control Panel User's Guide*