

# Operator's Manual

## ASCO® 7000 Series 7ADTB Automatic Delayed–Transition Transfer & Bypass–Isolation Switches H design 600 through 1200 amp.

### **⚠ DANGER**

**DANGER** is used in this manual to warn of high voltages capable of causing shock, burns, or death.

### **⚠ WARNING**

**WARNING** is used in this manual to warn of possible personal injury.

### **⚠ CAUTION**

**CAUTION** is used in this manual to warn of possible equipment damage.

Refer to the outline and wiring drawings provided with your 7000 Series ADTB for all installation and connection details and accessories.

Refer to *Group 5 Controller User's Guide* 381333–126 for ATS status display messages, time delays, pickup & dropout settings, and adjustments.

An experienced licensed electrician must install the 7ADTB.

### Rating Label

Each 7000 Series 7ADTB contains a rating label to define the loads and fault circuit withstand/closing ratings. Refer to the label on the Transfer Switch for specific values.

### **⚠ WARNING**

**Do not exceed the values on the nameplate/rating label. Exceeding the rating can cause personal injury or serious equipment damage.**



600–1200 amp. sizes

### TABLE OF CONTENTS

	section-page
<b>INSTALLATION</b>	
Mounting .....	1-1
Power Connections .....	1-1
Engine Starting & Auxiliary Circuits .....	1-2
Functional Test .....	1-2, 1-3, 1-4
<b>TESTING &amp; SERVICE</b>	
Transfer Test .....	2-1
Preventive Maintenance .....	2-1
Disconnecting the Controller .....	2-1
Manual Load Transfer .....	2-2
Trouble-Shooting .....	2-2
<b>BYPASSING &amp; ISOLATING</b>	
Bypassing the ATS .....	3-1, 3-2
Isolating the ATS .....	3-3, 3-4
Return to Service .....	3-5, 3-6, 3-7
INDEX .....	back cover

## Nameplate

The Transfer Switch nameplate includes data for each specific 7000 Series 7ADTB. Use the switch only within the limits shown on this nameplate. A typical Catalog Number is shown below with its elements explained.

## Catalog Number Identification

Typical 7000 Series 7ADTB catalog no. for switched neutral, 3 pole, 600 amp, 480 V, in Type 1 enclosure:

H7ADTB		B	3	600	N	5	C		
<b>Neutral</b>		<b>Phase Poles</b>		<b>Amperes</b>		<b>Voltage</b>		<b>Controller</b>	<b>Enclosure</b>
A – solid		2 – single Ø		600		C 208 K 415		5 – standard	C – type 1
B – switched		3 – three Ø		800		D 220 L 440		5X – if accessories ordered	F – type 3R
blank – none				1000		E 230 M 460			G – type 4
				1200		F 240 N 480			L – type 12
						G 277 P 550			blank – open type
						H 380 Q 575			
						J 400 R 600			

Status Lights & Engine Control

Bypass Handle

Isolation Handle

Transfer Switch

Transfer Control & Lights

Group 5 Controller

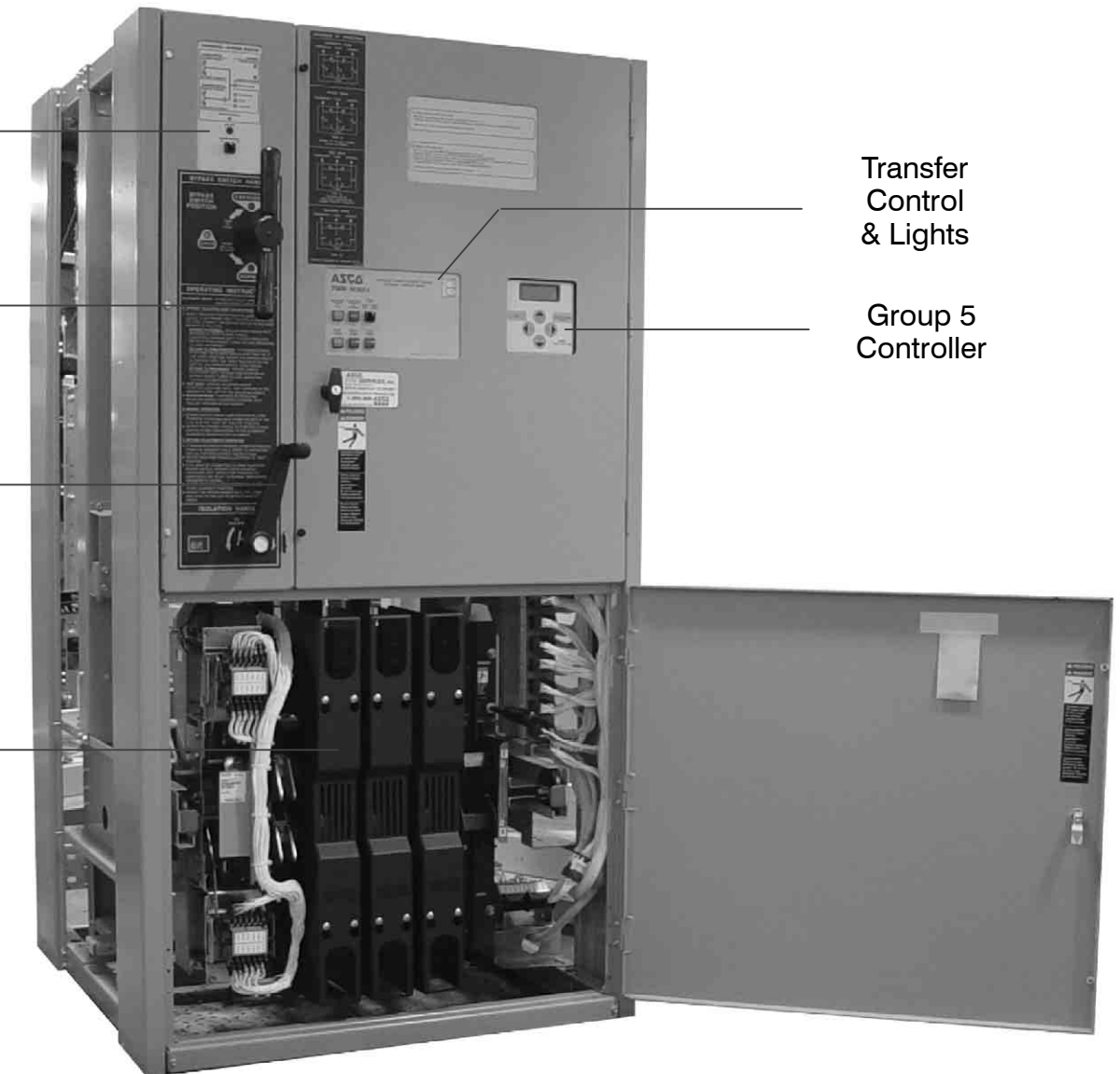

open-type H7ADTB with the lower door open (transfer switch shown)

## SECTION 1 INSTALLATION

ASCO 7000 Series Automatic Delayed-Transition Transfer & Bypass-Isolation Switches (7ADTBs) are factory wired and tested. Field installation requires mounting and connection of service cables, and auxiliary control circuits (if required).

### Remove the Shipping Skid

Open the front door and remove the four lag screws (2 in front, 2 in rear) securing enclosure to the shipping skid.

### Supporting Foundation

The supporting foundation for the enclosure must be level and straight. Refer to the applicable enclosure outline drawing included with the switch for all mounting details including door opening space.

If bottom cable entry is used, the foundation must be prepared so that the conduit stubs are located correctly. Refer to the enclosure outline drawing for specified area and location. Provide cable bending space and clearance to live metal parts. When a concrete floor is poured, use interlocking conduit spacer caps or a wood or metal template to maintain proper conduit alignment.

### Mounting

Refer to the applicable enclosure outline drawing furnished with this switch and mount the automatic transfer switch according to details and instructions shown on diagram.

### Line Connections

Refer to the Wiring Diagram provided with the switch. All wiring must be made in accordance with the National Electrical Code and local codes.

Do not remove the interphase barriers from the transfer switch. Always protect the transfer switch, bypass switch, and isolation contacts and mechanisms from construction grit and metal chips when cabling.

### DANGER

**De-energize the conductors before making any line or auxiliary circuitry connections. Be sure that Normal and Emergency line connections are in proper phase rotation. Place engine generator starting control in the OFF position. Make sure engine generator is not in operation.**

### Testing Power Conductors

Do not connect the power conductors to the transfer switch until they are tested. Installing power cables in conduit, cable troughs and ceiling-suspended hangers often requires considerable force. The pulling of cables can damage insulation and stretch or break the conductor's strands. For this reason, after the cables are pulled into position, and before they are connected, they should be tested to verify that they are not defective or have been damaged during installation.

### CAUTION

**Protect the switch from construction grit and metal chips to prevent malfunction or shortened life of the 7ADTB switch.**

### Connecting Power Conductors

After the power cables have been tested, connect them to the appropriate terminal lugs on the bypass switch as shown on the wiring diagram provided with the switch. Make sure the lugs provided are suitable for use with the cables being installed. Standard terminal lugs are solderless screw type and will accept the wire sizes listed on the drawings provided with the 7ADTB. Be careful when stripping insulation from the cables; avoid nicking or ringing the conductor. Remove surface oxides from cables by cleaning with a wire brush. When aluminum cable is used, apply joint compound to conductors. Tighten cable lugs to the torque specified on rating label.

### Controller Ground

A grounding wire must be connected to the controller's lower left mounting stud. Because the controller is mounted on the enclosure door, a conductive strap must be used between the enclosure and the door. This connection provides proper grounding which does not rely upon the door hinges.

### Harnesses

The transfer switch is connected to the left side of the controller by a plug-in harness (two plugs).

## INSTALLATION (continued)

### Engine Starting Contacts

All customer connections, including the engine control contact connections, are located on terminal block TB which is mounted on the top right side of the enclosure. Refer to the wiring diagram provided with the automatic transfer switch and connect the engine start wires to the appropriate terminals. See Figure 1-1 and Table A.

Table A. Engine start connections.

When normal source fails	Terminals on Terminal Block TB
contact closes	TB1 and TB2
contact opens	TB1 and TB3

**Note:** To temporarily disable engine control from the automatic transfer switch you can unplug J3 from the small P3 receptacle at the bottom of the assembly. Be sure to reconnect plug J3 to the P3 receptacle for automatic transfer switch operation.

### Auxiliary Circuits

Connect auxiliary circuit wires to appropriate terminals on transfer switch terminal block TB as shown on the wiring diagram provided with this automatic transfer switch.

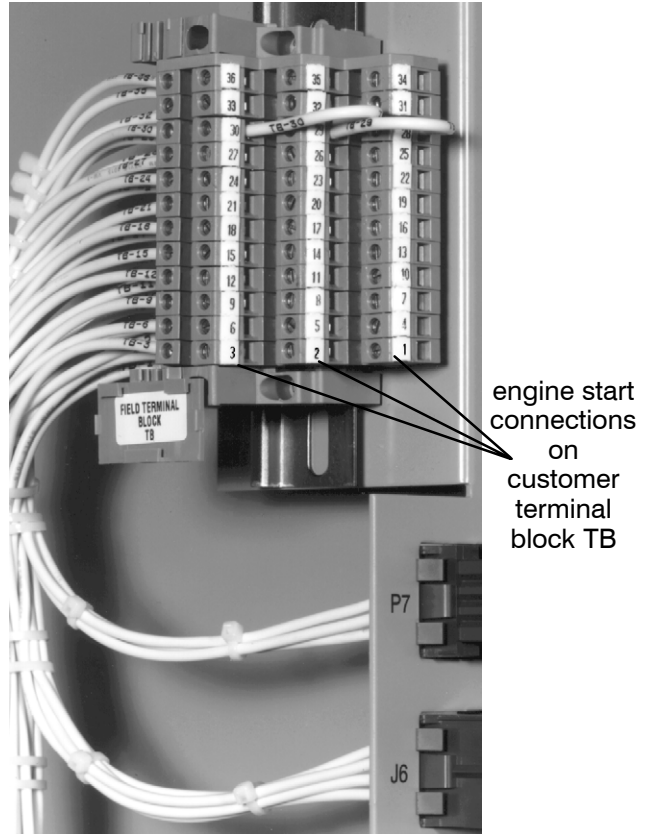

Figure 1-1. Customer terminal block on the top right side of the enclosure.

## Functional Test

The Functional Test consists of two checks:

- 1 — Voltage Checks, page 1-3
- 2 — Electrical Operation, page 1-4

### **CAUTION**

**Do these checks in the order presented to avoid damaging the 7ADTB.**

Read all instructions on the Wiring Diagram and labels affixed to the automatic transfer & bypass-isolation switch. Note the control features that are provided and review their operation before proceeding.

Continue to **1 – Voltage Checks** on next page.

**ASCO**® 7000 SERIES  
Power Transfer & Bypass Switch

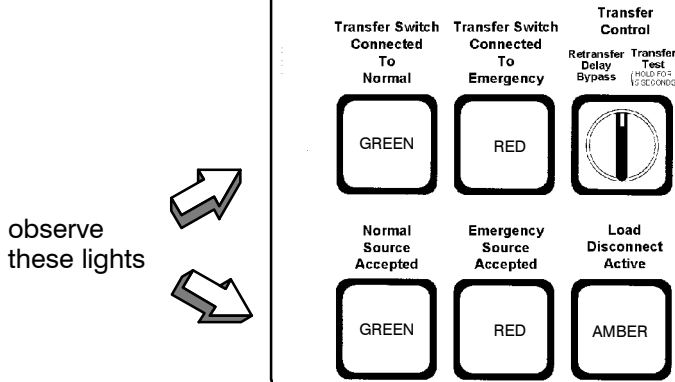

Figure 1-2. Standard controls and indicators.

**Functional Test**

Read all instructions on the *Wiring Diagrams* and labels affixed to the 7ADTB. Note the control features that are provided and review their operation before proceeding.

After installing the 7ADTB check the following:

- Bypass Handle should be in the *NORMAL* position.
- Isolation Handle should be in the *CONN* position.
- CN transfer switch should be *C* (closed)
- CE transfer switch should be *O* (open)

If handles are not in correct positions, follow instructions for Bypassing and Isolating the automatic transfer switch in **Section 3**. **Do not force the handles.** Electrical interlocks prevent a wrong sequence of operation.

**1 – Voltage Checks**

First check nameplate on transfer switch; rated voltage must be the same as normal and emergency line voltages.

**⚠ DANGER**

**Use extreme caution when using a meter to measure voltages. Do not touch power terminals; shock, burns, or death could result !**

Perform steps 1–6 at the right. Observe the status lights. See Figure 1–2.

- Black square means light is on.
- White square means light is off.

\* If necessary, adjust voltage regulator on generator per the manufacturer’s recommendations. The 7ADTB will respond only to rated voltage specified on the nameplate.

Now continue to **2 – Electrical Operation** on next page.

1	Close the normal source circuit breaker. The <i>Transfer Switch Connected To Normal</i> and the <i>Normal Source Accepted</i> lights should come on.	
2	Use an accurate voltmeter to check phase to phase and phase to neutral voltages present at the transfer switch normal source terminals.	
3	Close the emergency source circuit breaker. (Start generator, if necessary.) The <i>Transfer Switch Connected To Normal &amp; Emergency Source Accepted</i> lights should come on.	
4	Use an accurate voltmeter to check phase to phase and phase to neutral voltages present at the transfer switch emergency source terminals.*	
5	Use a phase rotation meter to check phase rotation of emergency source; it must be the <u>same</u> as the normal source.	
6	Shut down the engine-generator, if applicable. The <i>Emergency Source Accepted</i> light should go off. Then put the starting control selector switch (on the generator set) in the <i>automatic</i> position. Close enclosure door.	

**ASCO**<sup>®</sup> 7000 SERIES  
Power Transfer & Bypass Switch

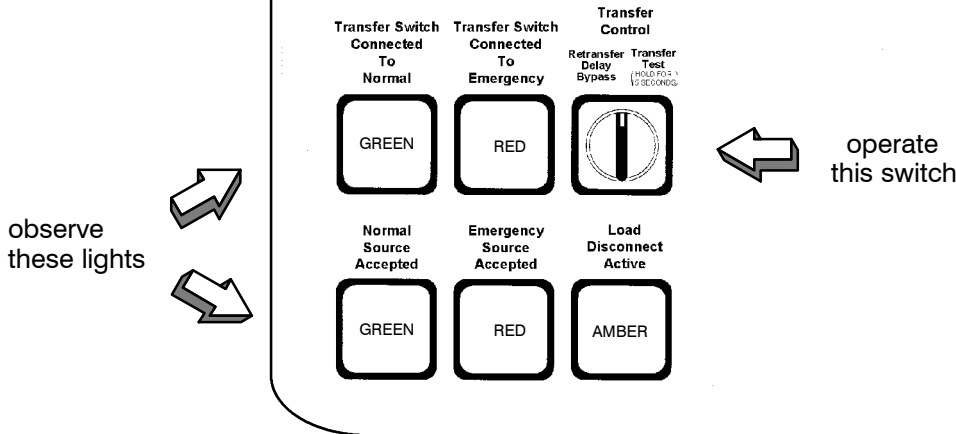

Figure 1-3. Standard controls and indicators.

**2 – Electrical Operation**

This procedure checks electrical operation of the ADTS.

**⚠ WARNING**

**Close enclosure door before proceeding to prevent personal injury in case of electrical system fault.**

*Transfer Test*

The ATS should still be bypassed. Both normal and emergency sources must be available and the emergency source generator (if used) must be capable of being started; put engine starting control in *automatic* position. The *Transfer Switch Connected to Normal* light and the *Normal Source Accepted* light should be on.

1. Turn the **Isolation Handle** counterclockwise to the *TEST* position.  
**NOTE:** The engine generator may be signalled to start while turning the Isolation Handle. If emergency source is available, the ATS may operate to the emergency position. If it does, operate **Retransfer Delay Bypass** switch.
2. Perform steps 1–5 at right. Observe the status lights. See Figure 1–3.
  - Black square means light is on.
  - White square means light is off.
3. Turn the **Isolation Handle** clockwise to the *CONN* (connected) position.
4. Turn **Bypass Handle** clockwise to the *OPEN* position.

This completes the Functional Test of the 7ADTB.

1	Turn and <u>hold</u> <b>Transfer Control</b> switch clockwise to <i>Transfer Test</i> until the engine starts and runs (within 15 sec.). The <i>Emergency Source Accepted</i> light should come on.	
2	Transfer switch CN opens and the <i>Transfer Switch Connected to Normal</i> light should go off and the <i>Load Disconnect Active</i> light should come on. Both CN & CE contacts are now open.	
3	After the delay transition time delay, the CE Transfer switch will operate to the Emergency position. The <i>Transfer Switch Connected To Emergency</i> light should come on and <i>Load Disconnect Active</i> light goes off.	
4	Transfer switch will operate back to Normal position after Feature 3A time delay. For immediate retransfer turn <b>Transfer Control</b> counterclockwise to <i>Retransfer Delay Bypass</i> . The <i>Transfer Switch Connected To Normal</i> light should come on; <i>Transfer Switch Connected to Emergency</i> light should go off.	
5	The engine-generator will stop after the Feature 2E time delay (unloaded running engine cool-down). The <i>Emergency Source Accepted</i> light should go off.	

## SECTION 2 TESTING & SERVICE

### TRANSFER TEST

Test the Automatic Transfer Switch portion of the 7000 Series 7ADTB at least once a month. This procedure checks the electrical operation of the Transfer Switch and Controller. Put the engine-generator starting control (at the engine-generator set) in automatic mode.

In the following test the generator will start, the load will be transferred to the Emergency source, then back to the Normal source. An interruption to the load will occur, unless the the Transfer Switch contacts are bypassed before the test. See pages 3-1 through 3-4 for bypassing & isolating instructions if no interruption of load is required.

#### **WARNING**

**Be sure to close the enclosure door before proceeding to prevent personal injury in case of electrical system fault.**

Perform the five-step **Electrical Operation – Transfer Test** procedure on page 1-4.

### PREVENTIVE MAINTENANCE

Reasonable care in preventive maintenance will insure high reliability and long life for the 7000 Series 7ADTB. An annual preventive maintenance program is recommended.

ASCO Services, Inc. (ASI) is ASCO Power Technologies's national service organization. In the US ASI can be contacted at 1-800-800-2726 for information on preventive maintenance agreements.

### Checklist for Yearly Inspection

#### **DANGER**

**Hazardous voltage capable of causing shock, burns, or death is used in this switch. Deenergize both Normal – Emergency power sources before performing inspections!**

- Clean the 7ADTB enclosure.**  
Brush and vacuum away any excessive dust accumulation. Remove any moisture with a clean cloth.
- Check the transfer switch contacts.**  
Bypass, isolate, and withdraw the transfer switch. Then remove the transfer switch interphase barriers and check the condition of the contacts. Replace contacts when pitted or worn excessively. Reinstall the interphase barriers carefully. See page 3-4.
- Maintain transfer switch lubrication.**  
If switch is subjected to severe dust or abnormal operating conditions, renew factory lubrication on all movements and linkages. Relubricate solenoid operator if TS coil is replaced. Don't use oil; order *lubrication kit 75-100*.
- Check all cable connections & retighten them.**

### REPLACEMENT PARTS

Replacement parts are available in kit form. When ordering parts provide the Serial No., Bill of Material No. (BOM), and Catalog No. from the transfer switch nameplate. Contact your local ASCO Power Technologies Sales Office or ASI:

#### **In the United States**

**call 1 – 800 – 800 – ASCO ( 2726 )**

#### **In Canada**

**call 1 – 888 – 234 – ASCO ( 2726 )**

### DISCONNECTING THE CONTROLLER

The harness disconnect plugs are furnished for repair purposes only and should not have to be unplugged. If the controller must be isolated, follow these steps:

#### **DANGER**

**Bypass-Isolation Switch is energized! Do not touch isolation contact fingers; shock, burns, or death could result!**

### Disconnecting the Plugs

1. Bypass and Isolate the Automatic Transfer Switch.
2. Open the upper enclosure door.
3. Separate the two quick disconnect plugs by squeezing the latches. Do not pull on the harness wires.

### Reconnecting the Plugs

1. The ATS should be still bypassed and isolated.
2. The two harness plugs and sockets are keyed. Carefully align the plugs with the sockets and press straight in until the latches click.
3. Close the enclosure doors.
4. Follow *Return to Service* instructions on page 3-5.

### MANUAL LOAD TRANSFER

This procedure manually transfers load to other source if the Transfer Switch or Controller are out of service.

#### **WARNING**

**Close enclosure doors to prevent personal injury in case of electrical system fault.**

1. Bypass the connected 7ADTB source. Turn Bypass Handle to *EMERGENCY* or *NORMAL* (see page 3-2).
2. Isolate to Test. Turn the Isolation Handle to *TEST* position (see page 3-3).
3. Turn the Bypass Handle to *OPEN*, then to the other source (see page 3-1). The load will be interrupted.
4. Turn the Isolation Handle clockwise to the *CONN* [connected] position (see page 3-4).

# TESTING & SERVICE *(continued)*

## TROUBLE-SHOOTING

Note any optional accessories that may be furnished on the 7ADTB and review their operation. Refer to any separate drawings and/or instructions that may be packed with the 7ADTB. See Table B.

**⚠ DANGER**

Hazardous voltage capable of causing shock, burns, or death is used in this switch. Do not touch the power or load terminals of the bypass switch or transfer switch!

Table B. Trouble-Shooting Checks.

PROBLEM	CHECK IN NUMERICAL SEQUENCE		
	1 OPERATION	2 GEN-SET	3 VOLTAGE
Engine-generator set does not start when the <b>Transfer Control</b> switch is turned and held in <i>Transfer Test</i> position or when normal source fails.	Hold <i>Transfer Test</i> switch 15 seconds or the outage must be long enough to allow for Feature 1C time delay plus engine cranking and starting.	Starting control must be in the automatic position. Batteries must be charged and connected. Check wiring to engine starting contacts.	-
Transfer switch does not transfer the load to the emergency source after the engine-generator set starts.	Wait for Feature 2B time delay to time out.	Generator output circuit breaker must be closed. Generator frequency must be at least 95% of nominal (57 Hz for a 60 Hz system.) *	Voltmeter should read at least 90% of nominal phase to phase voltage between terminals EA and EC (or EL1 and EL2 for 2 pole switches)*
Transfer switch does not transfer the load to normal source when normal returns or when the <b>Transfer Control</b> switch is released.	Wait for Feature 3A time delay to time out.	-	Voltmeter should read at least 90% of nominal phase to phase voltage between terminals NB and NC, NC and NA, and NA and NB (or NL1 and NL2 for 2 pole switches).
Gen. does not stop after load retransfer to normal source.	Wait for Feature 2E time delay to time out.	Starting control must be in the automatic position.	-
<i>Load Disconnect Active</i> light comes on.	Wait for load disconnect time delay to time out.	Explanation: Transfer switch in delayed transition transfer mode. Load disconnect time delay is adjustable from 0 to 5 min. 59 sec.	
<i>Load Disconnect Active</i> light stays on longer than 6 min.	Check load disconnect time delay setting. Call ASI.	Explanation: Transfer switch contacts are open longer than 5 min. 59 sec (maximum setting). Load remains disconnected.	

\* These are factory settings. Refer to **Controller's User's Guide**.

If the problem is isolated to circuits on the controller or the transfer switch, call your local ASCO Power Technologies sales office or ASI: in the United States, call 1-800-800-2726 or in Canada call 1-888-234-2726. Furnish the Serial No., Catalog No., and Bill of Material (BOM) No. from the transfer switch nameplate.

## MAINTENANCE HANDLE

**⚠ DANGER**

Bypass and isolate the Transfer Switch before using the maintenance handle! See pages 3-1 through 3-4. Remove the maintenance handle after using it; store it inside.

1. Bypass, isolate, and withdraw the transfer switch (pages 3-1 through 3-4). Then locate and remove the maintenance handle from the clip (inside lower left side). Insert the handle onto the shaft on the left side of the operator of the transfer switch. See Figures 2-1, 2-2, 2-3 and Table C.
2. Move the maintenance handle up or down as shown to manually operate the transfer switch. Operate both upper and lower contact shafts. Observe the window indicators (right side). Remove the maintenance handle and store it on the lower left side.

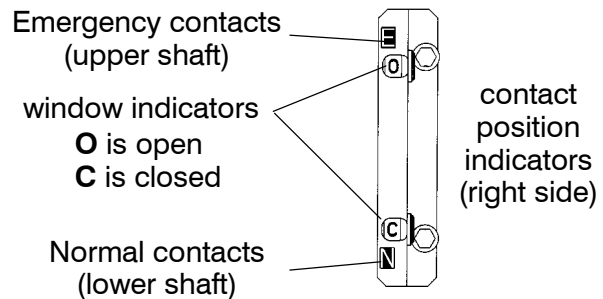

Figure 2-1. Contact position indicators.

Note: If Normal and Emergency connections are reversed this operation is also reversed.

## TESTING & SERVICE *(continued)*

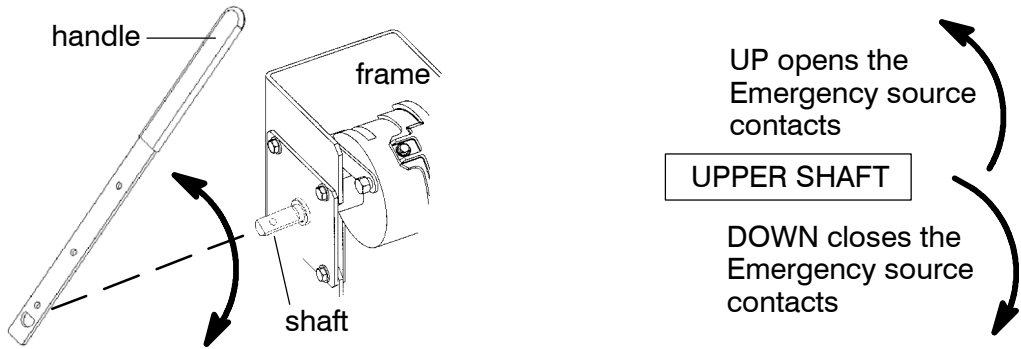

Figure 2-2. Maintenance handle operation for Emergency source contacts (upper shaft).

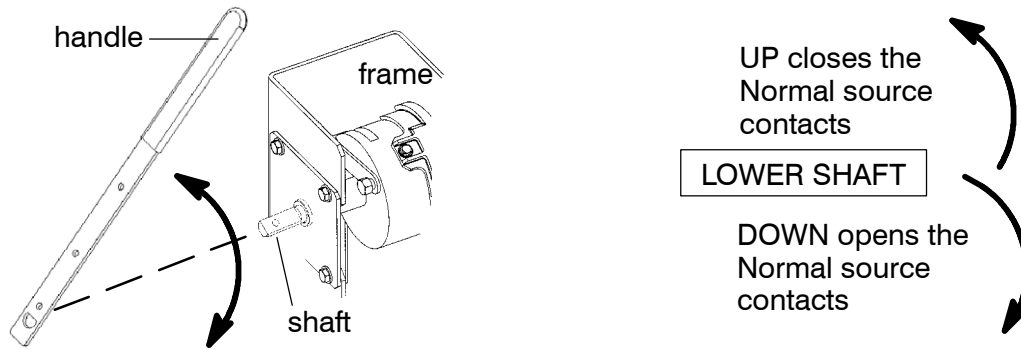

Figure 2-3. Maintenance handle operation for Normal source contacts (lower shaft).

Table C. Maintenance handle positions.

Transfer Switch Position		Interlocked Weights Lobes prevent closing both N & E contacts	Maintenance Handle	Shaft Indicators
Normal			up	E = O upper contacts open
			down	N = C lower contacts closed
Load Disconnected			up	E = O upper contacts open
			down	N = O lower contacts open
Emergency			down	E = C upper contacts closed
			down	N = O lower contacts open

## SECTION 3 BYPASSING & ISOLATING

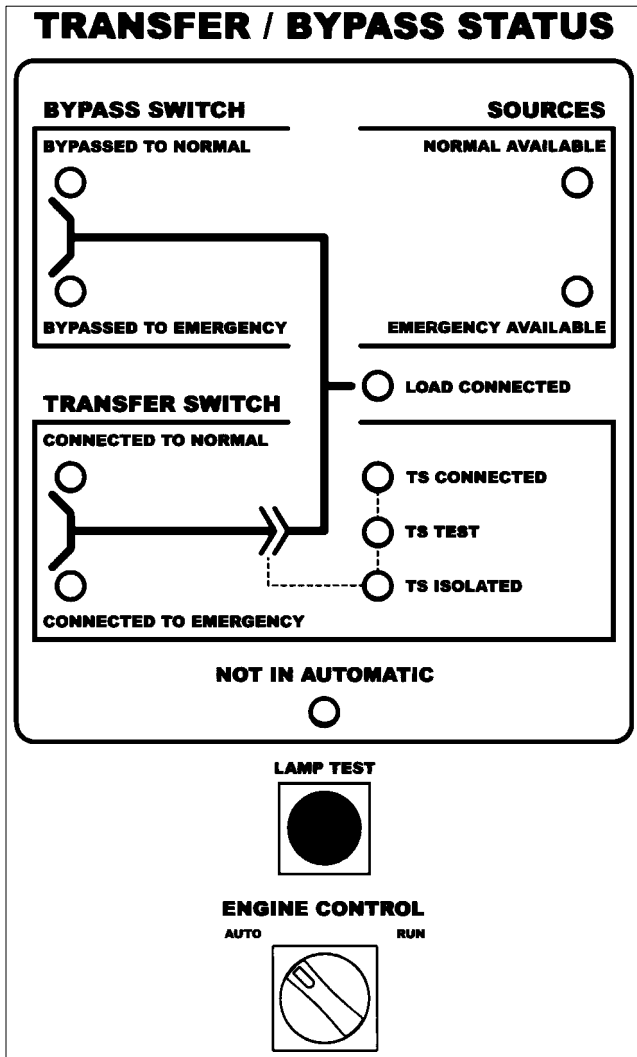

Figure 3-1. Status lights and Engine Control.

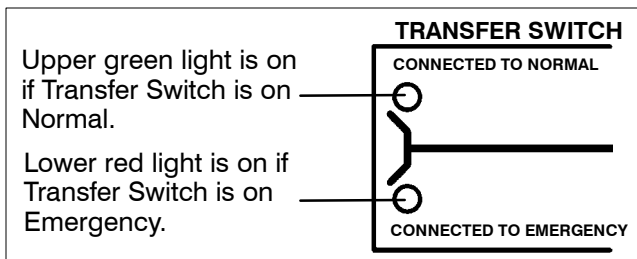

Figure 3-2. Status lights for Transfer Switch main contact position.

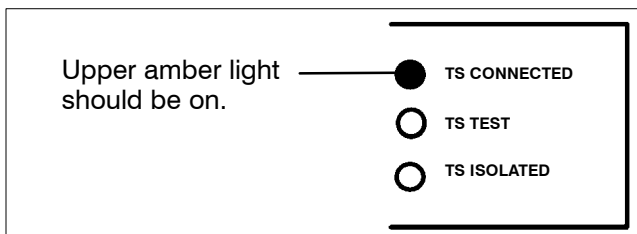

Figure 3-3. Status lights for Transfer Switch isolation contact position.

### BYPASSING THE ATS\*

This procedure explains how to Bypass the closed transfer switch contacts. Bypassing is required before the Transfer Switch can be tested or isolated. The Bypass Switch Handle must be in the *OPEN* position (green window indicator) and the Isolation Handle must be in the *CONN* [connected] position (window indicator). The *TS Connected* light must be on. See Figures 3-1, 3-2, 3-3.

**⚠ CAUTION**

**You can only bypass to the same source that the Transfer Switch is connected. Solenoid interlock prevents incorrect operation.**

1. Observe which *Transfer Switch Connected To* light is on (*Normal* or *Emergency*) on the door. This is the position of the transfer switch (see Figure 3-2).
2. Follow the directions on next page to Bypass to the same source as connected to transfer switch (select *Normal* or *Emergency*).

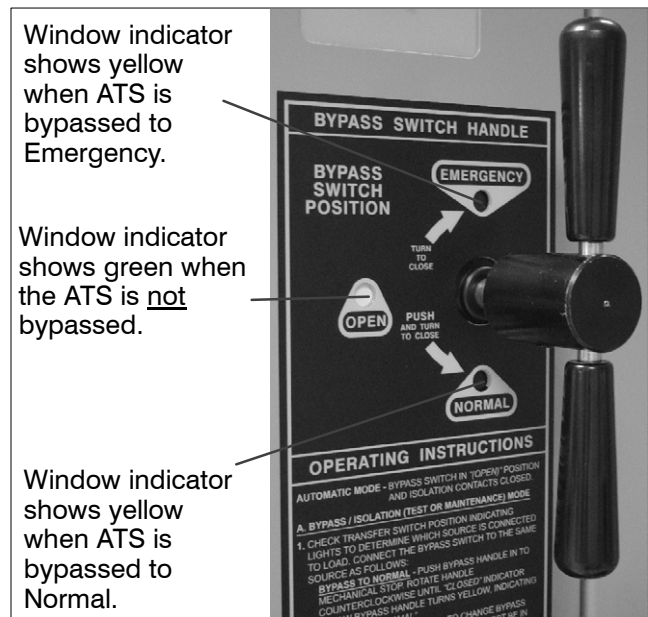

Figure 3-4. Bypass Handle and three position window indicators.

**Allowable Positons of the Bypass Switch in relation to Positons of the Transfer Switch (with Isolation Handle in the *Conn* [connected] positon and *TS Connected* light on)**

Transfer Switch	Bypass Switch can be in either	
If Transfer Switch is in Normal position.	Open or	Normal
If Transfer Switch is in Emergency position.	Open or	Emergency

## BYPASSING & ISOLATING (continued)

### To Bypass Normal Source\*

(Load connected to Normal Source)

The *Transfer Switch Connected To Normal* light is on and *Transfer Switch Connected To Emergency* light is off.

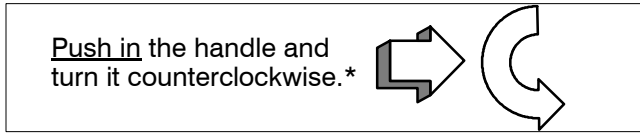

Push in\* the Bypass Handle all the way, then turn it counterclockwise until *Bypass Switch Position* shows closed on NORMAL (yellow window indicator). The green light *Bypassed to Normal* will come on and the amber light *Not In Automatic* will flash.

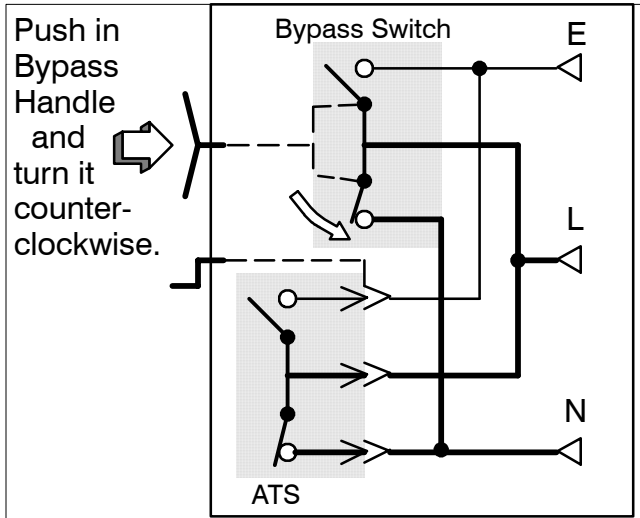
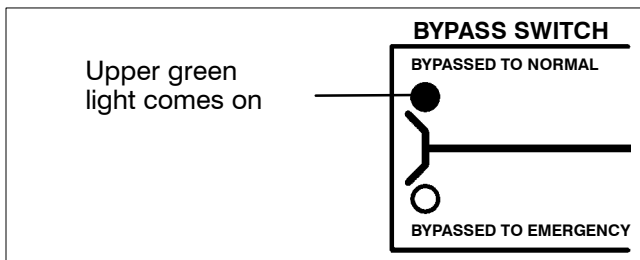

Figure 3-5. Bypass to Normal diagram.



Lower window indicator NORMAL shows yellow

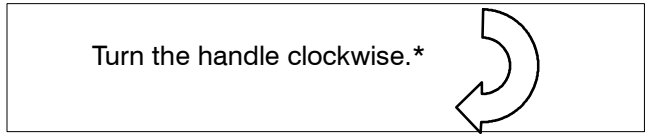

Figure 3-6. Status light and window indicator for Bypassed to Normal Source.

### To Bypass Emergency Source\*

(Load connected to Emergency Source)

The *Transfer Switch Connected To Emergency* light is on and *Transfer Switch Connected To Normal* light is off.



Turn\* the Bypass Handle clockwise until *Bypass Switch Position* shows closed on EMERGENCY (yellow window indicator). The red light *Bypassed to Emergency* will come on and the amber light *Not In Automatic* will flash.

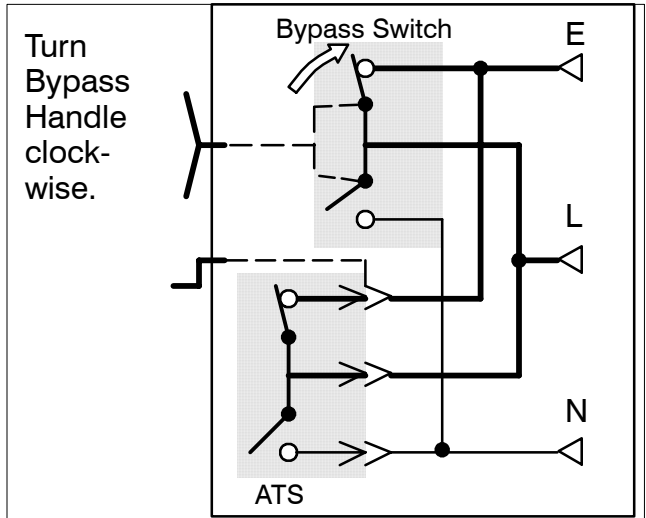
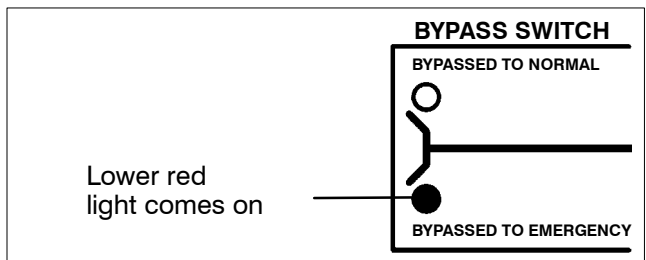

Figure 3-7. Bypass to Emergency diagram.



Upper window indicator EMERGENCY shows yellow



Figure 3-8. Status light and window indicator for Bypassed to Emergency Source.

The automatic transfer switch can now be put in the *TEST* or *OPEN* position. See **ISOLATING** on page 3-3.

\* **NOTE:** When Accessory 40\*B (reversed Normal & Emergency connections) is specified, the handle operation is reversed. Follow instructions on the door.

# BYPASSING & ISOLATING *(continued)*

## ISOLATING THE ATS

Isolating is required before any service work can be performed on the automatic transfer switch (ATS). Refer to Figures 3-9, 3-10, 3-11, and 3-12.

1. Bypass the closed automatic transfer switch contacts. See **BYPASSING** on pages 3-1 and 3-2.
2. Turn the Isolation Handle counterclockwise (approx. 8 turns) until window shows *TEST*. The *TS Test* amber light should come on. The ATS can be tested now without load interruption (see page 2-1).

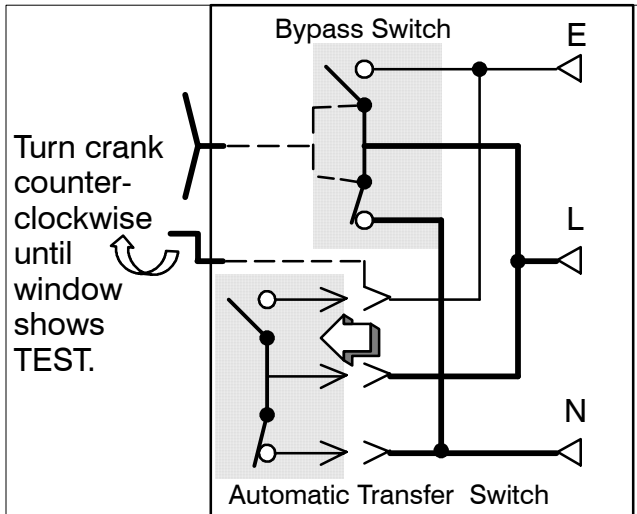
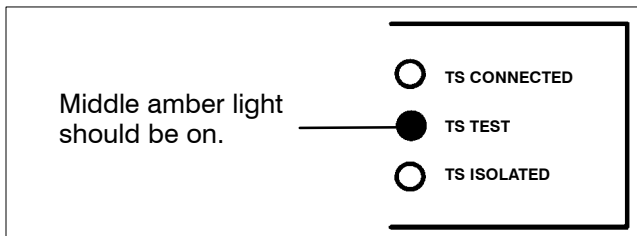

Figure 3-9. *CONNECTED* to *TEST* position.



**NOTE:** In the *TEST* position the transfer switch solenoid operator circuit is energized through secondary disconnects.

**⚠ DANGER**

**Hazardous voltage capable of causing electrical shock, burns, or death; do not touch any control circuit terminals.**

3. Continue turning Isolation Handle counterclockwise (approx. 6 turns) until the window shows *ISOLATE*. The *TS Isolated* amber light should come on.

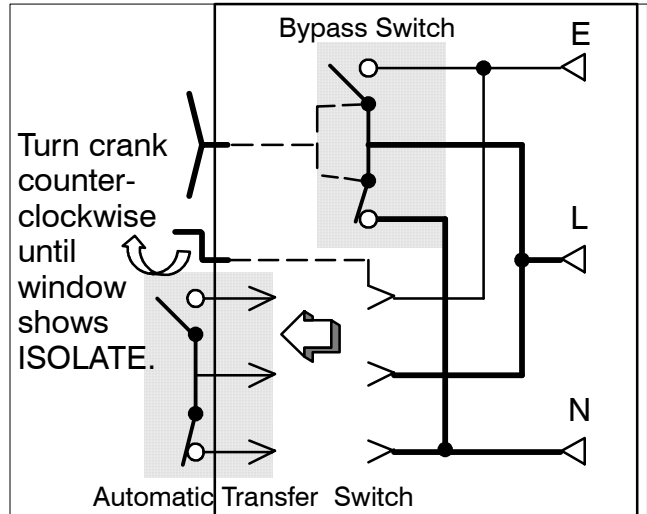
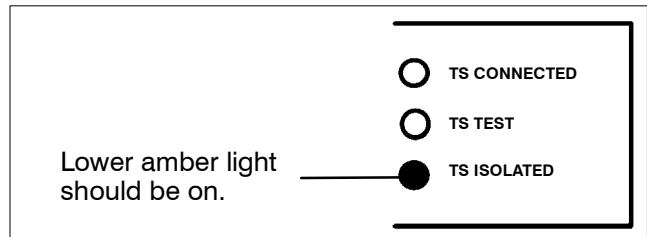

Figure 3-11. *TEST* to *ISOLATE* position.



position window **CONN TEST ISOLATE** counterclockwise – draws out the transfer switch

Figure 3-10. Isolation Handle turned to *TEST*.



position window **CONN TEST ISOLATE** counterclockwise – draws out the transfer switch

Figure 3-12. Isolation Handle turned to *ISOLATE*.

## BYPASSING & ISOLATING *(continued)*

4. Open the lower enclosure door. Pull out both left and right side rails then use the two handles to roll out the transfer switch. It can be safely inspected in this position. The transfer switch can also be removed for easier maintenance operations. See Figure 3-13.

### **⚠ DANGER**

**Hazardous voltage capable of causing electrical shock, burns, or death; do not touch any control circuit terminals.**

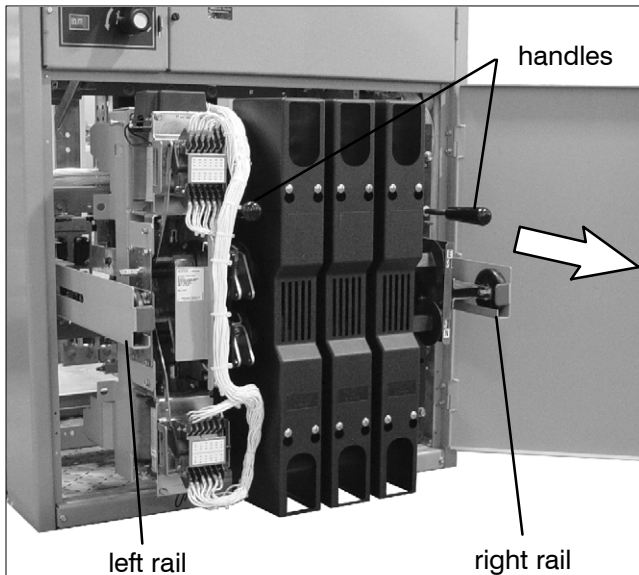

Figure 3-13. Transfer switch isolated and pulled out for inspection.

See page 2-2 for maintenance handle use. A lifting yoke 734408 is available to facilitate lifting by using an overhead crane or similar equipment. See **WARNING**.

### **⚠ WARNING**

**The Transfer Switch weighs 165–235 lbs. depending upon the number of poles. Use lifting device 734408 or other device capable of lifting this weight to avoid personal injury or equipment damage. Two persons are recommended.**

### Contact Inspection

The main contacts are protected by arcing contacts. The arcing contacts make first and break last to avoid arcing at the main contacts. Contact condition should be checked annually. Contacts should be replaced when contact material becomes severely worn. Discoloration is normal. Do not file contacts because it wastes material. Instead use light emery paper to clean up the contact surfaces.

If the contacts need to be replaced see page 2-2.

### **⚠ DANGER**

**To prevent the possibility of fatal electrical shocks and burns, bypass, isolate, and withdraw the transfer switch before working on it.**

The contact assemblies (two for each pole) are located to the right of the operator mechanism.

1. **Deenergize transfer switch** (pages 3-1 thru 3-4) Bypass, isolate, and withdraw transfer switch. Use a voltmeter to verify that no electrical power is present at the transfer switch terminals.
2. **Use the maintenance handle** (page 2-2). Open the contacts that will be inspected by using the detachable maintenance handle.
3. **Remove the interphase barriers** (Figure 3-14). Use a blade screwdriver to loosen (ccw) four round-head screws holding each barrier to the arc chutes. Slide barrier up until keyholes clear the round-head screws, then remove it.

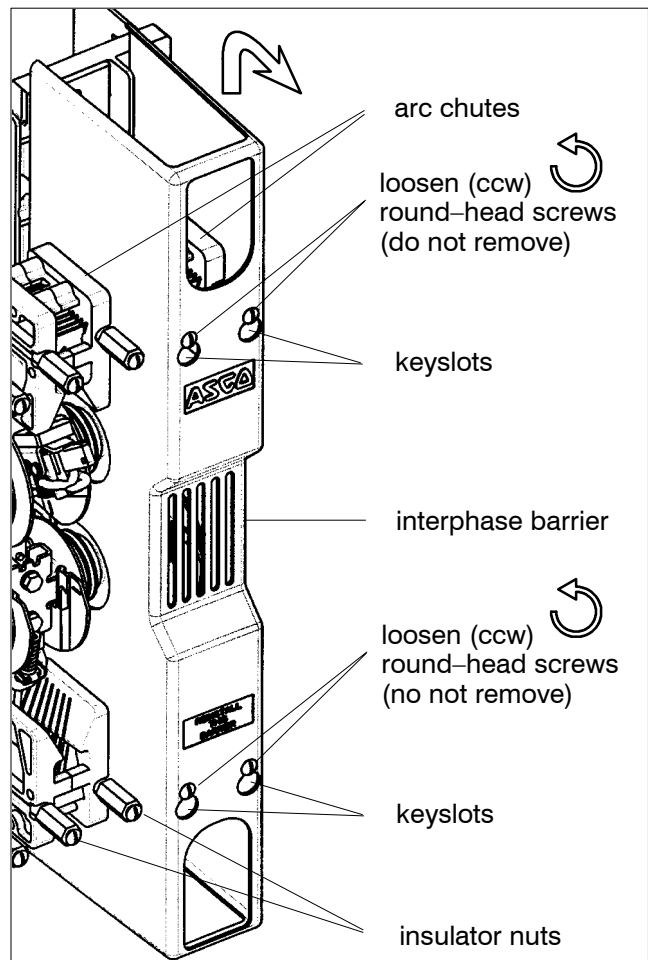

Figure 3-14. Interphase barrier removal.

4. **Remove the arc chutes.** Use a 5/8" nutdriver to remove (ccw) two long insulator nuts. Then pull the arc chute outward (off the long threaded rods). See Figure 3-14.

## BYPASSING & ISOLATING (continued)

### 5. Remove the movable contact cover.

Use your thumb and fingers to squeeze the sides inward until the contact cover is released from the shaft clamp (both sides). Then remove the movable contact cover. See Figures 3-15 & 3-16.

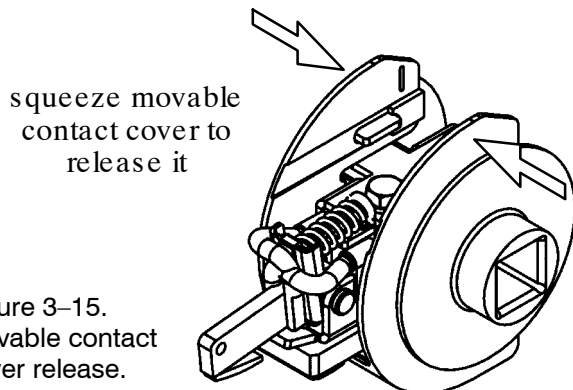

Figure 3-15. Movable contact cover release.

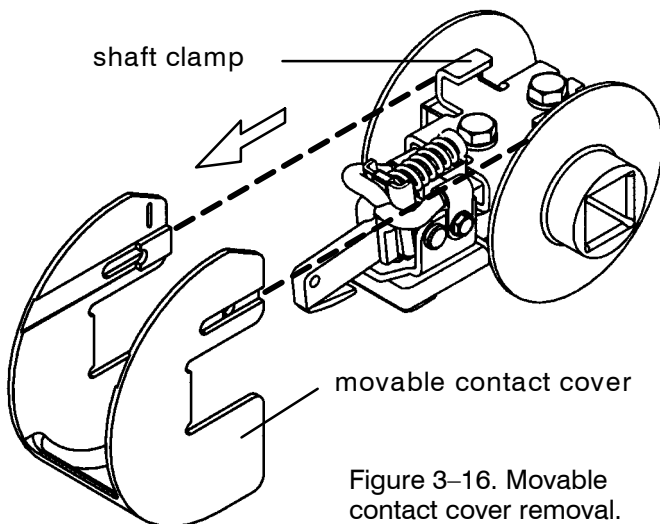

Figure 3-16. Movable contact cover removal.

### 6. Reinstall the movable contact cover.

After inspection reinstall the movable contact cover onto the movable contact assembly. Use your thumb and fingers to squeeze the sides inward until the contact cover is latched onto the metal bracket (both sides). Figures 3-15 & 3-16.

### 7. Reinstall the arc chute.

Slide the arc chute (arc splitters toward the contacts and recess for nuts outward) between the two long threaded rods. Reinstall the two long insulator nuts (round shoulder in) and use a 5/8" nutdriver to GENTLY tighten (cw) until snug. Do not over-tighten these nuts. See Figure 3-14.

### 8. Reinstall the interphase barrier.

Install the barrier over the arc chutes and slide it up until the four round-head screws align in the four keyholes in the barrier. Then slide the barrier down. Use a blade screwdriver to tighten (cw) the four round-head screws to secure the barrier to the arc chute insulator nuts. See Figure 3-14.

## RETURN TO SERVICE

This procedure explains how to return the automatic transfer switch (ATS) to service after inspection and maintenance. Observe the *Bypass Switch Position* indicator and lights).

1. Use the two handles to roll the transfer switch into the enclosure (isolation contacts facing inward) until its crank pins engage the latch plates on both sides. Next push in both side rails and close enclosure door.

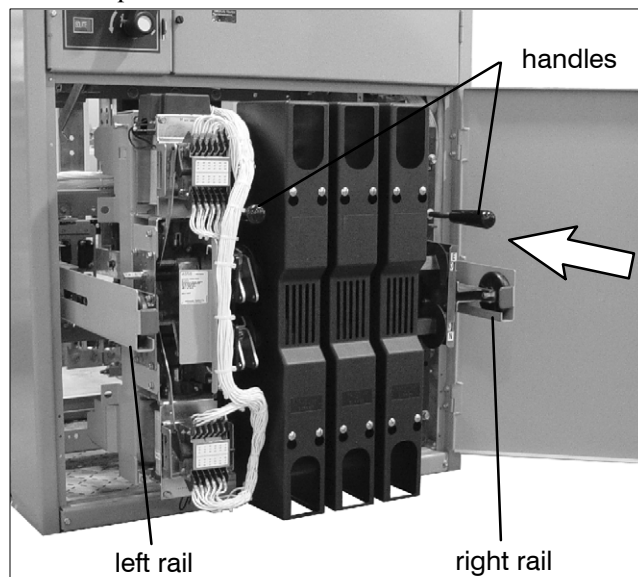

Figure 3-17. Transfer switch isolated and pulled out for inspection.

### ⚠ WARNING

**Close the enclosure door to prevent personal injury in case of electrical system fault.**

2. Turn Isolation Handle clockwise (approx. 6 turns) until the window shows *TEST* and *TS TEST* light comes on.

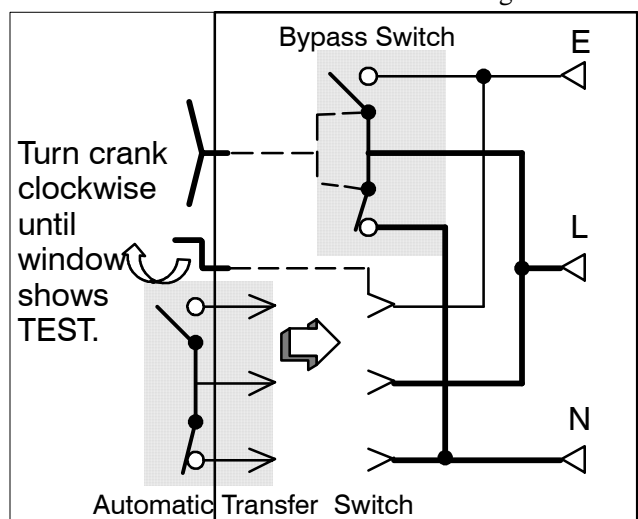
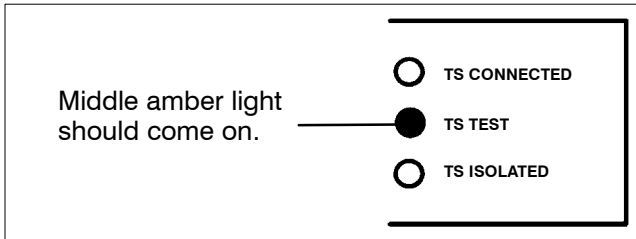

Figure 3-18. ISOLATE to TEST position.

## BYPASSING & ISOLATING *(continued)*



position window **TEST** ↻ clockwise – draws in the transfer switch

Figure 3-19. Isolation Handle turned to **TEST**.

- The ATS can be tested now without load interruption (see page 2-1).



- Observe which *Bypass Switch Position* window indicator is yellow (*NORMAL* or *EMERGENCY*) at the Bypass Switch Handle. This indicates the source connected to the load.
- Observe which *Transfer Switch Connected To* light is on (*Normal* or *Emergency*) on the door. This is the position of the Transfer Switch. If it is not in the same position as the Bypass Handle change the position of the Transfer Switch as follows:

### To change the position of transfer switch

Operate to <b>NORMAL</b>	Operate to <b>EMERGENCY</b>
Turn <b>Transfer Control</b> switch to <i>Retransfer Delay Bypass</i> .	Turn <b>Transfer Control</b> switch to <i>Transfer Test</i> (hold 15 seconds).*
<i>Connected To Normal</i> light should come on.	<i>Connected To Emergency</i> light should come on.

\* If Feature 2B time delay is used, there will be a delay before transfer to Emergency.

**NOTE:** With Normal available, the automatic transfer switch will not stay in the emergency position unless Feature 3A time delay is used (at least 30 seconds).

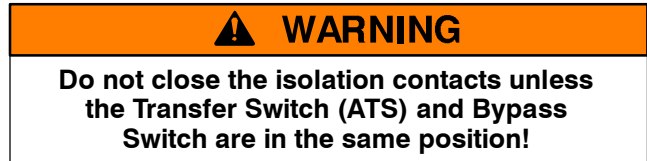

- When the transfer switch is in the same position as the Bypass Switch handle, continue turning the Isolation Handle clockwise (about 8 turns) until the window shows *CONN* (connected).

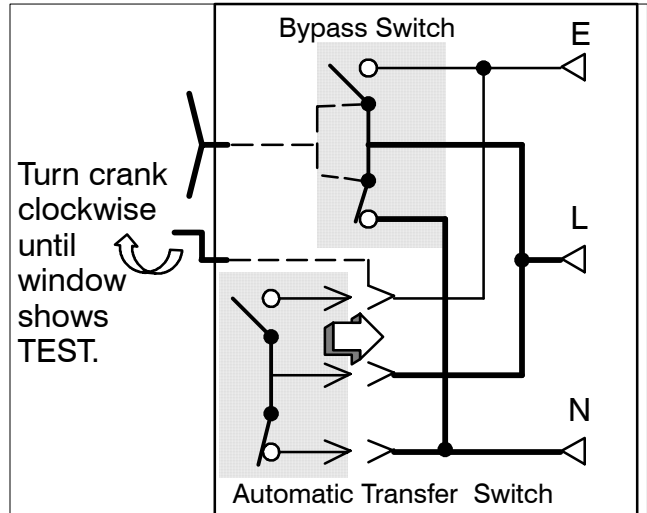
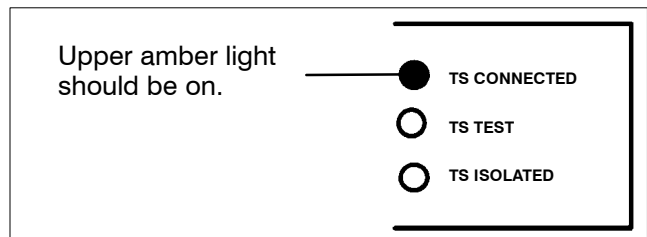

Figure 3-20. **TEST** to **CONN** (connected) position.



position window **CONN** ↻ clockwise – draws in the transfer switch

Figure 3-21. Isolation Handle turned to **CONN**.



# INDEX

## A

auxiliary circuits, 1–2

## B

barriers, interphase, 3–4, 3–5  
bypassing the ATS, 3–1, 3–2

## C

catalog number, 1–1  
cleaning, 2–1  
connections  
  power, 1–1  
contact inspection, 3–4, 3–5  
controller  
  disconnecting, 2–1  
  see *Controller User's Guide*

## D

delayed transition transfer, 1–4  
  see *Controller User's Guide*

## E

electrical operation, 1–4  
Emergency Source Accepted light,  
  1–3  
engine starting contacts, 1–2

## F

foundation, 1–1  
frequency, generator, 2–2  
functional test, 1–2, 1–3, 1–4

## H

harness, 1–2  
  disconnect plugs, 2–1

## HELP

customercare@asco.com  
800–800–2726 (ASCO)

## I

indicators, contact position, 2–2, 2–3  
inspection, 3–1  
installation, 1–1  
interlocked weights, 2–3  
interphase barriers, 3–4, 3–5  
isolating the ATS, 3–3, 3–4

## L

lifting device, transfer switch, 3–4  
lights, 1–2, 1–3, 3–1, 3–2, 3–3  
load connected to emergency, 1–3  
load connected to normal, 1–3  
Load Disconnect Active light, 1–4  
lubrication, 2–1

## M

maintenance, preventive, 2–1  
maintenance handle, 2–3  
  warning, 2–3  
manual load transfer, 2–3  
  warning, 2–3

## N

nameplate, 1–1  
Normal Source Accepted light, 1–3

## O

operation  
  electrical, 1–4  
  manual, 2–3  
  warning, 2–3  
optional accessories  
  see *Controller User's Guide*

## P

parts, 2–1  
phase rotation check, 1–3  
preventive maintenance, 2–1  
problem, 2–2

## R

rating label, cover  
replacement parts, 2–1  
return to service, 3–5, 3–6, 3–7

## S

service  
  ASCO Services, Inc. (ASI), 2–1  
settings  
  see *Controller User's Guide*

## T

test, functional, 1–2, 1–3, 1–4  
testing power cables, 1–1  
time delays, 2–1  
  see *Controller User's Guide*  
Transfer Control selector switch  
  Retransfer Delay Bypass, 1–3  
  Transfer Test, 1–3  
Transfer Switch Connected To  
  Emergency light, 1–3  
Transfer Switch Connected To  
  Normal light, 1–3  
transfer test, 1–4, 2–1  
transfer to emergency, 1–4, 2–1  
transfer to normal, 1–4, 2–1  
troubleshooting, 2–2

## V

voltage checks, 1–3  
voltage, pickup and dropout settings  
  see *Controller User's Guide*