

Operator's Manual

ASCO® 7000 Series ATS Automatic Transfer Switches D design, 30 through 230 amps

⚠ DANGER

DANGER is used in this manual to warn of high voltages capable of causing shock, burns, or death.

⚠ WARNING

WARNING is used in this manual to warn of possible personal injury.

⚠ CAUTION

CAUTION is used in this manual to warn of possible equipment damage.

Refer to the outline and wiring drawings provided with your 7000 Series ATS for all installation and connection details and accessories.

Refer to *Group 5 Controller User's Guide* 381333-126 for ATS status display messages, time delays, pickup & dropout settings, and adjustments.

Rating Label

Each Automatic Transfer Switch contains a rating label to define the loads and fault circuit withstand/closing ratings. Refer to the label on the Transfer Switch for specific values.

⚠ WARNING

Do not exceed the values on the rating label. Exceeding the rating can cause personal injury or serious equipment damage.

Nameplate

The Transfer Switch nameplate includes data for each specific 7000 Series ATS. Use the switch only within the limits shown on this nameplate. A typical Catalog Number is shown on the next page with its elements explained.

An experienced licensed electrician must install the ATS.



30–230 amp. size

TABLE OF CONTENTS

	section-page
INSTALLATION	1-1
Mounting and Line Connections	1-1
Auxiliary Circuits and Harness	1-2
Engine Starting Contacts	1-2
Functional Test	1-2, 1-3, 1-4
TESTING & SERVICE	2-1
Transfer Test	2-1
Preventive Maintenance	2-1
Disconnecting the Controller	2-1
Manual Load Transfer	2-2
Trouble-Shooting	2-2
INDEX	back cover

Catalog Number Identification

Typical 7000 Series 7ATS catalog no. for overlapping neutral, 3 pole, 150 amp, 480 V, in Type 1 enclosure:

design prefix letter	D	7ATS	C	3	150	N	5	C
	Neutral	Phase Poles	Amperes	Voltage	Controller	Enclosure		
	A – solid B – switched C – overlapping blank – none	2 – single Ø 3 – three Ø	30 70 100 150 200 ** 230 **	A 115 J 400 B 120 K 415 C 208 L 440 D 220 M 460 E 230 N 480 F 240 P 550 G 277 Q 575 H 380 R 600	5 – standard 5X – if accessories ordered	C – type 1 F – type 3R G – type 4 L – type 12 M –type 3R secure N –type 4 secure P –type 4X secure Q –type 12 secure blank – open type		

** 200 and 230 amp. limited to 480 volts

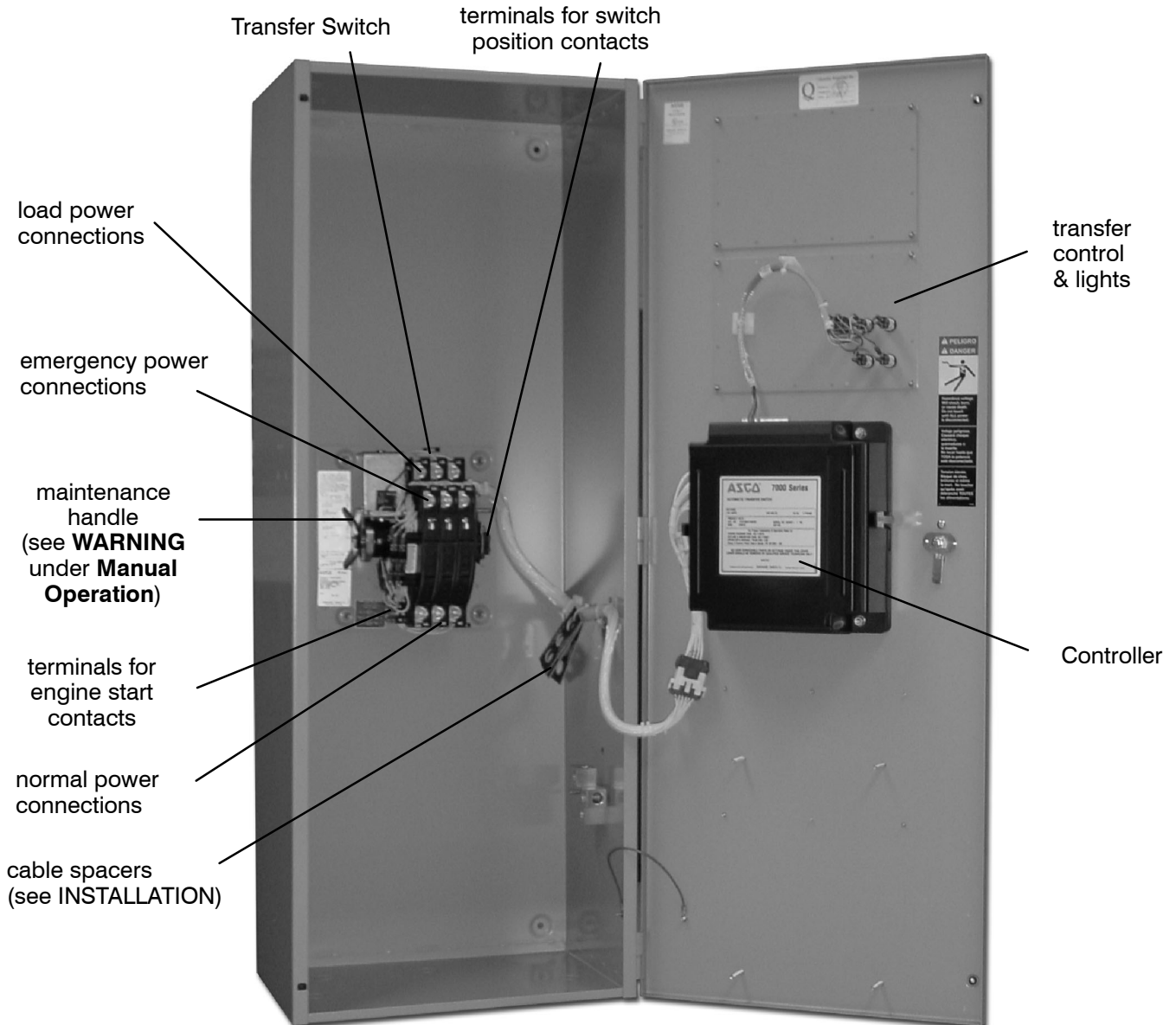

150 amp. size in typical enclosure with location of customer connections

SECTION 1 INSTALLATION

The ASCO 7000 Series Automatic Transfer Switch (ATS) is factory wired and tested. Field installation requires mounting, connecting service cables, and connecting engine start and auxiliary control circuits (if required).

Supporting Foundation

The supporting foundation for the enclosure must be level and straight. Refer to the applicable enclosure outline drawing included with the switch for all mounting details including door opening space.

If bottom cable entry is used, the foundation must be prepared so that the conduit stubs are located correctly. Refer to the enclosure outline drawing for specified area and location. Provide cable bending space and ½ inch minimum clearance to live metal parts. When a concrete floor is poured, use interlocking conduit spacer caps or a wood or metal template to maintain proper conduit alignment.

Mounting

Refer to the *Outline and Mounting Diagram* provided with the ATS; it shows all mounting details and instructions.

⚠ CAUTION

Protect the switch from construction grit and metal chips to prevent malfunction or shortened life of the automatic switch switch.

Mount the ASCO ATS vertically to a rigid supporting structure. Level all mounting points by using flat washers behind the holes to avoid distortion of the switch.

The controller is mounted on the cabinet door. An add-on DIN rail is provided for some optional accessories and is mounted below the controller on the door.

Line Connections

A *Wiring Diagram* is furnished with the ASCO 7000 Series ATS (separate from this manual). Refer to this drawing. All wiring must be made in accordance with the National Electrical Code and local codes.

⚠ DANGER

De-energize the conductors before making any line or auxiliary circuitry connections. Be sure that Normal and Emergency line connections are in proper phase rotation. Place engine generator starting control in the OFF position. Make sure engine generator is not in operation.

Testing Power Conductors

Do not connect the power conductors to the transfer switch until they are tested. Installing power cables in

conduit, cable troughs and ceiling-suspended hangers often requires considerable force. The pulling of cables can damage insulation and stretch or break the conductor's strands. For this reason, after the cables are pulled into position, and before they are connected, they should be tested to verify that they are not defective or have been damaged during installation.

Connecting Power Conductors

After the power cables have been tested, connect them to the appropriate terminal lugs on the transfer switch as shown on the wiring diagram provided with the switch. Make sure the lugs provided are suitable for use with the cables being installed. Standard terminal lugs are solderless screw type and will accept the wire sizes listed on the drawings provided with the switch. Be careful when stripping insulation from the cables; avoid nicking or ringing the conductor. Remove surface oxides from cables by cleaning with a wire brush. When aluminum cable is used, apply joint compound to conductors. Tighten cable lugs to the torque specified on rating label.

Three cable spacers are included with 150, 200, & 230 amp transfer switches. When installing power cables, run the cables through the cable spacers as shown in Figure 1-1. Position the cable spacers within 1½ inches from the lugs.

⚠ CAUTION

The cable spacers must be located as shown for 150, 200, and 230 ampere transfer switches.

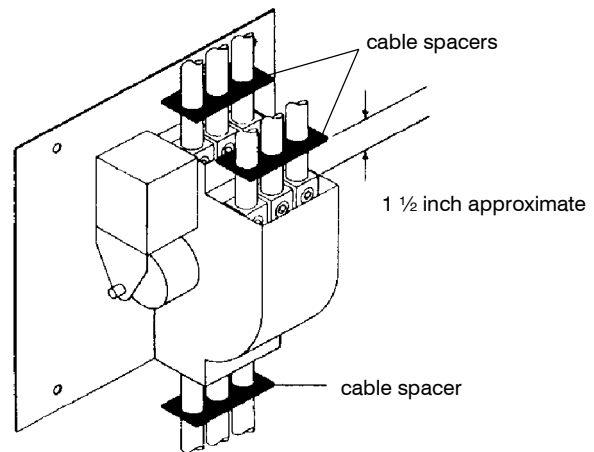

Figure 1-1. Cable spacer for 150, 200, and 230 amp. transfer switches.

Controller Ground

A grounding wire must be connected to the controller's lower left mounting stud. Because the controller is mounted on the enclosure door, a conductive strap must be used between the enclosure and the door. This connection provides proper grounding which does not rely upon the door hinges.

INSTALLATION (continued)

Harnesses

The transfer switch is connected to the left side of the controller by a plug-in harness (two plugs).

Engine Starting Contacts

The engine control contact connections (if used) are located on the transfer switch. Connect signal wires to appropriate terminals as specified in Table A and shown in Figure 1-2.

Table A. Engine Start Connections

When normal source fails	Terminals on transfer switch
contact closes	TB14 and TB15
contact opens	TB14 and TB16

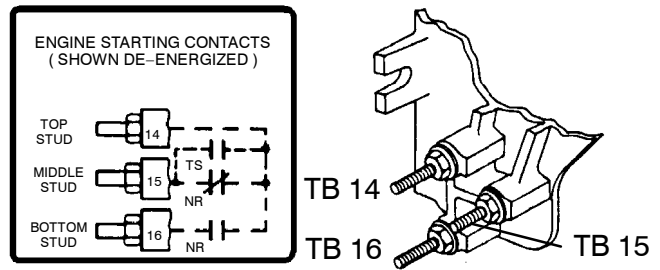

Figure 1-2. Engine starting contact label and location on left side of transfer switch.

Auxiliary Circuits

Connect auxiliary circuit wires to appropriate terminals on the transfer switch. Note the control features that are furnished on this switch. Make the necessary auxiliary connections by referring to the Wiring Diagram.

Functional Test

The Functional Test consists of three checks:

- V 1 — Manual Operation Test, on this page
- V 2 — Voltage Checks, page 1-3
- V 3 — Electrical Operation, page 1-4

⚠ CAUTION

Do these checks in the order presented to avoid damaging the ATS.

Read all instructions on the Wiring Diagram and labels affixed to the automatic transfer switch. Note the control features that are provided and review their operation before proceeding.

1 – Manual Operation Test

A maintenance handle is provided on the Transfer Switch for maintenance purposes only. Manual operation of the transfer switch should be checked before it is energized (operated electrically).

⚠ WARNING

Do not manually operate the transfer switch until both power sources are disconnected: open both circuit breakers.

1. After deenergizing both power sources, open the enclosure door. Locate and the maintenance handle on the left side of the transfer switch. See Figure 1-3.
2. Grasp the attached maintenance handle and turn it with thumb and fingers as shown to manually operate it. The maintenance handle turns the opposite direction of the weight. Turn it up or down as shown to manually

operate the transfer switch. It should operate smoothly without any binding. If it does not, check for shipping damage or construction debris.

3. Return the transfer switch to the Normal position.

Note: If Normal and Emergency connections are reversed this operation is also reversed.

Now continue to 2 – Voltage Checks on next page.

Position of the transfer switch is indicated here

weight marked **N** (normal) and **E** (emergency)

maintenance handle

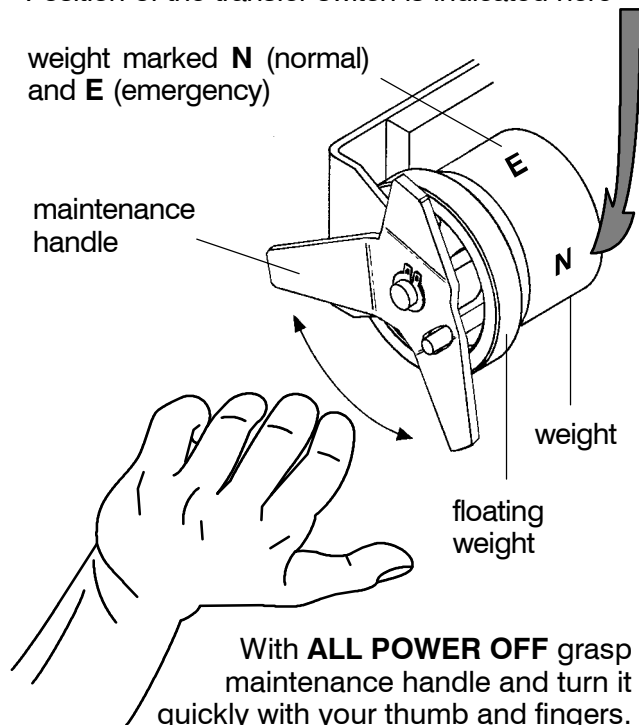

With ALL POWER OFF grasp maintenance handle and turn it quickly with your thumb and fingers.

Figure 1-3. Maintenance handle and positions.

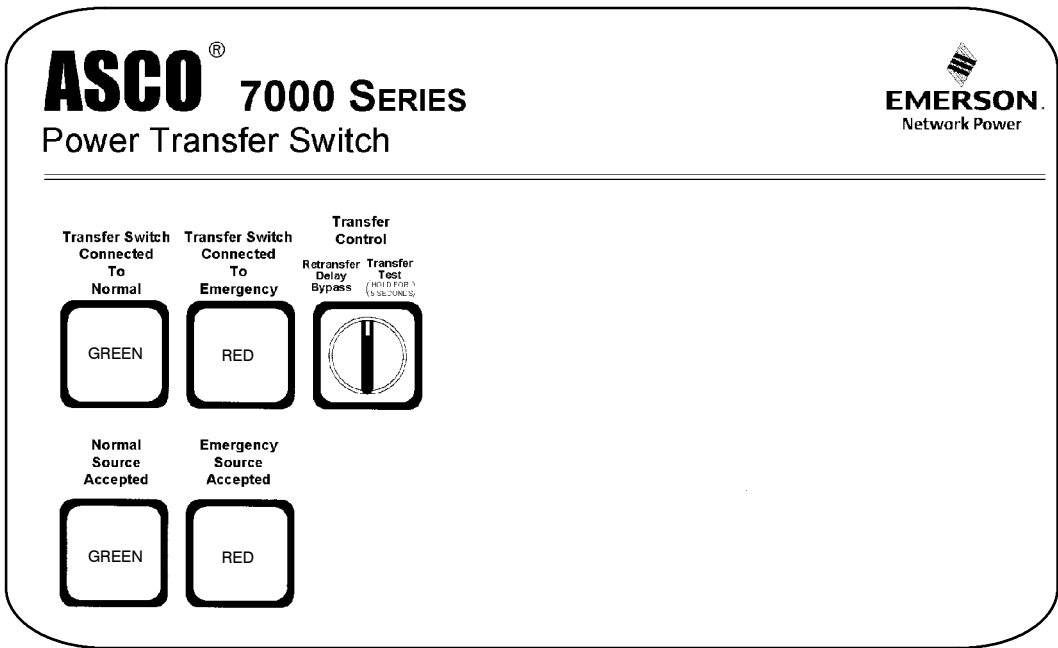

Figure 1-4. Standard controls and indicators.

2 – Voltage Checks

First check nameplate on transfer switch; rated voltage must be the same as normal and emergency line voltages.

CAUTION

Verify that the feeders have been connected to the proper lugs.

DANGER

Use extreme caution when using a meter to measure voltages. Do not touch power terminals; shock, burns, or death could result !

Perform steps 1 through 6 at the right. Observe the status lights. See Figure 1-4.

- Black square means light is on.
- White square means light is off.

* If necessary, adjust voltage regulator on the generator according to the manufacturer’s recommendations. The Automatic Transfer Switch will respond only to the rated voltage specified on the Transfer Switch nameplate.

Note

Refer to Section 3 of *Group 5 Controller User’s Guide* 381333-126 for how to display the Status of the ATS and the Voltage and Frequency of each source.

Now continue to **3 – Electrical Operation** on next page.

1	Close the normal source circuit breaker. The <i>Transfer Switch Connected To Normal</i> and the <i>Normal Source Accepted</i> lights should come on.	
2	Use an accurate voltmeter to check phase to phase and phase to neutral voltages present at the transfer switch normal source terminals.	
3	Close the emergency source circuit breaker. (Start generator, if necessary.) The <i>Transfer Switch Connected To Normal & Emergency Source Accepted</i> lights should come on.	
4	Use an accurate voltmeter to check phase to phase and phase to neutral voltages present at the transfer switch emergency source terminals.*	
5	Use a phase rotation meter to check phase rotation of emergency source; it must be the <u>same</u> as the normal source.	
6	Shut down the engine-generator, if applicable. The <i>Emergency Source Accepted</i> light should go off. Then put the starting control selector switch (on the generator set) in the <i>automatic</i> position. Close enclosure door.	

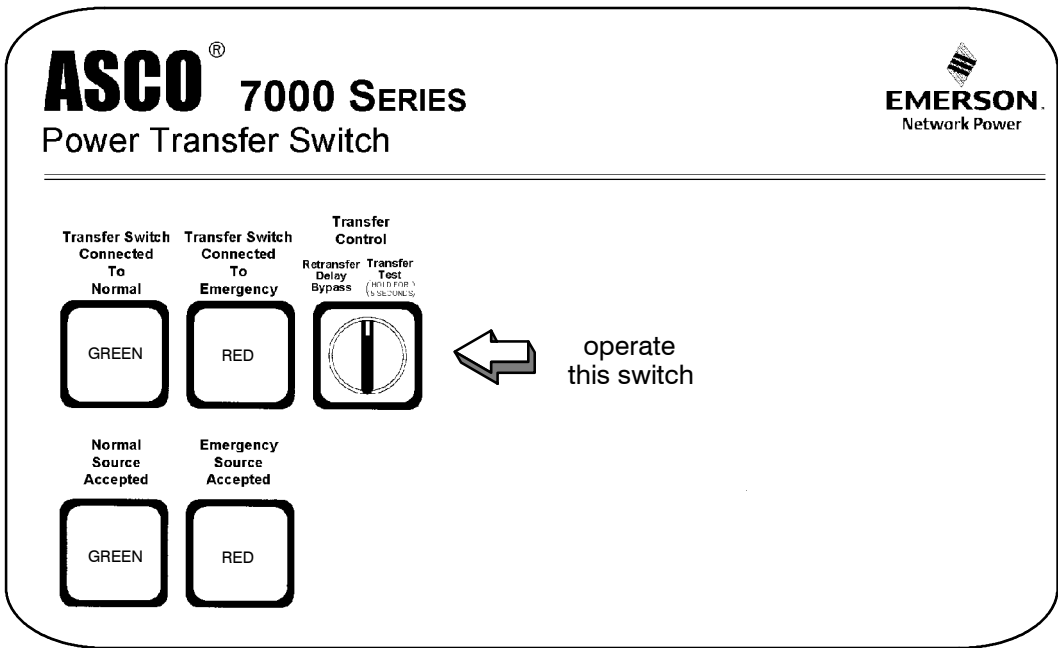

Figure 1-5. Standard controls and indicators.

3 – Electrical Operation

This procedure will check the electrical operation of the Automatic Transfer Switch. See Figure 1-5.

WARNING

Close the enclosure door first.

Transfer Test

Both normal and emergency sources must be available and the emergency source generator (if used) must be capable of being started in this procedure.

Perform steps 1 through 5 at the right. Observe the status lights.

- Black square means light is on.
- White square means light is off.

This completes the Functional Test of the ATS.

1	The <i>Transfer Switch Connected To Normal</i> and <i>Normal Source Accepted</i> lights should be on.	
2	Turn and <u>hold</u> Transfer Control switch clockwise to <i>Transfer Test</i> until the engine starts and runs (within 15 sec.). <i>Emergency Source Accepted</i> light should come on.	
3	Transfer switch will operate to the Emergency position after Feature 2B time delay. The <i>Transfer Switch Connected To Emergency</i> light should come on and <i>Load Connected to Normal</i> light goes off.	
4	Transfer switch will operate back to Normal position after Feature 3A time delay. For immediate retransfer turn Transfer Control counterclockwise to <i>Retransfer Delay Bypass</i> . The <i>Transfer Switch Connected To Normal</i> light should come on; <i>Transfer Switch Connected to Emergency</i> light should go off.	
5	The engine-generator will stop after the Feature 2E time delay (unloaded running engine cool-down). The <i>Emergency Source Accepted</i> light should go off.	

SECTION 2 TESTING & SERVICE

TRANSFER TEST

Operate the 7000 Series ATS at least once a month by following the five-step **Electrical Operation Transfer Test** procedure on page 1-4.

PREVENTIVE MAINTENANCE

Reasonable care in preventive maintenance will insure high reliability and long life for the 7000 Series ATS. An annual preventive maintenance program is recommended.

ASCO Services, Inc. (ASI) is ASCO Power Technologies's national service organization. ASI can be contacted at 1-800-800-2726 for information on preventive maintenance agreements. In Canada call 1-888-234-ASCO (2726).

Checklist for Yearly Inspection

DANGER

Hazardous voltage capable of causing shock, burns, or death is used in this transfer switch. Deenergize both Normal – Emergency power sources before performing inspections!

- j **Clean the ATS enclosure.**
Brush and vacuum away any excessive dust accumulation. Remove any moisture with a clean cloth.
- j **Check the transfer switch contacts.**
Remove the transfer switch barriers and check contact condition. Replace the contacts if they become pitted or worn excessively. Reinstall the barriers carefully.
- j **Maintain transfer switch lubrication.**
The transfer switch has been properly lubricated, and under normal operating conditions no further lubricating is required. Renew factory lubrication if the switch is subjected to severe dust or abnormal operating conditions. Relubricate the operator if TS coil is replaced. Order **lubrication 625550-001** (Castrol *EndurexR* 4000 lubricant).
- j **Check all cable connections & retighten them.**

REPLACEMENT PARTS

Replacement parts are available in kit form. When ordering parts provide the Serial No., Bill of Material No. (BOM), and Catalog No. from the transfer switch nameplate. Contact your local ASCO Power Technologies sales office or ASI. In the United States call 1-800-800-ASCO (2726), or in Canada call 1-888-234-ASCO (2726).

DISCONNECTING THE CONTROLLER

The harness disconnect plugs are furnished for repair purposes only and should not have to be unplugged. If the controller must be isolated, follow these steps:

Disconnecting the Plugs

WARNING

Do not unplug the controller until steps 1a or 1b is completed.

1. Observe the position of the transfer switch.
 - a. If the transfer switch is in the *Normal* position, first place standby engine starting control in the *off* position. Second, then open the emergency source circuit breaker. Third, open the normal source circuit breaker.
 - b. If the transfer switch is in the *Emergency* position, first open the normal source circuit breaker. Second, place the engine starting control in the *test* or *run* position. Third, open the emergency source circuit breaker.
2. Separate the two quick disconnect plugs by squeezing the latches. Do not pull on the harness wires.

Reconnecting the Plugs

WARNING

Do not reconnect the controller until steps 1a or 1b is completed.

1. Observe the position of the transfer switch.
 - a. If the transfer switch is in the *Normal* position, first be sure that **both** normal and emergency source circuit breakers are open. Second, be sure that the standby engine starting control is still in the *off* position.
 - b. If the transfer switch is in the *Emergency* position, first be sure that **both** normal and emergency source circuit breakers are open.
2. The two harness plugs and sockets are keyed. Carefully align the plugs with the sockets and press straight in until both latches click. **Close the door!**
3. Restore the two sources in sequence as follows:
 - a. If the transfer switch is in the *Normal* position, first close the normal source circuit breaker. Second, close the emergency source circuit breaker. Third, place the standby engine starting control in the *automatic* position.
 - b. If the transfer switch is in the *Emergency* position, first close the emergency source circuit breaker. Second close the normal source circuit breaker.

TESTING & SERVICE (continued)

MANUAL LOAD TRANSFER

This procedure will manually transfer the load if the controller is disconnected.

WARNING

Do not manually operate the transfer switch until both power sources are disconnected (all conductors deenergized).

1. Deenergize both the normal and emergency source conductors (remove fuses or open circuit breakers).

WARNING

Verify that the maintenance handle has been removed before proceeding!

2. Use the maintenance handle to manually operate the transfer switch to the opposite source. See *Manual Operation* on page 1–2.

3. If the transfer switch is in the Emergency position manually start the engine generator and then install emergency source fuse or close the circuit breaker.

TROUBLE-SHOOTING

Note any optional accessories that may be furnished on the automatic transfer switch (ATS) and review their operation. Refer to any separate drawings and/or instructions that may be packed with the ATS.

DANGER

Hazardous voltage capable of causing shock, burns, or death is used in this switch. Do not touch the power or load terminals of the transfer switch!

Table 2-1. Trouble-Shooting Checks.

PROBLEM	CHECK IN NUMERICAL SEQUENCE		
	1 OPERATION	2 GEN-SET	3 VOLTAGE
Engine-generator set does not start when the Transfer Control switch is turned and <u>held</u> in <i>Transfer Test</i> position or when the normal source fails.	Hold <i>Transfer Test</i> switch 15 seconds or the outage must be long enough to allow for Feature 1C time delay plus engine cranking and starting time.	Starting control must be in the automatic position. Batteries must be charged and connected. Check wiring to engine starting contacts on customer terminal block TB. Verify that the small plug J3 is connected to receptacle P3.	–
Transfer switch does not transfer the load to the emergency source after the engine-generator set starts.	Wait for Feature 2B time delay to time out (if used).	Generator output circuit breaker must be closed. Generator frequency must be at least 95% of nominal (57 Hz for a 60 Hz system.) *	Voltmeter should read at least 90% of nominal phase to phase voltage between transfer switch terminals EA and EC (or EL1 and EL2 for 2 pole switches). *
Transfer switch does not transfer the load to normal source when normal returns or when the Transfer Control switch is released.	Wait for Feature 3A time delay to time out (if used).	–	Voltmeter should read at least 90% of nominal phase to phase voltage between transfer switch terminals NB and NC, NC and NA, and NA and NB (or NL1 and NL2 for 2 pole switches).
Engine-generator-set does not stop after load retransfer to the normal source.	Wait for Feature 2E time delay to time out (if used).	Starting control must be in the automatic position.	–

* These are factory settings. Refer to the **Group 5 Controller User's Guide**.

If the problem is isolated to circuits on the controller or the transfer switch, call your local ASCO Power Technologies sales office or ASI. In the United States, call 1–800–800–2726. In Canada, call 1–888–234–2726. Furnish the Serial No., Bill of Material (BOM) No., & Catalog No. from transfer switch nameplate.

INDEX

A

auxiliary circuits, 1–2

C

cable

lugs, 1–1

preparation, 1–1

spacers, 1–1

illustration of, 1–1

catalog number, inside cover

cleaning, 2–1

connections

line, 1–1

controller, 1–1, 1–2

disconnecting, 2–1

see *Controller User's Guide*

grounding, 1–1

E

electrical operation, 1–4

Emergency Source Accepted light,
1–3, 1–4

F

frequency, generator, 2–2

functional test, 1–2, 1–3, 1–4

H

harness, 1–2

disconnect plugs, 2–1

help, 2–2

I

inspection, 2–1

installation, 1–1

L

labels,

engine start contacts, 1–2

rating, cover

lights, 1–3, 1–4

lubrication, 2–1

M

maintenance, preventive, 2–1

manual load transfer, 2–2

warning, 2–2

manual operation, 1–2

illustration of, 1–2

warning, 1–2

N

nameplate, cover

Normal Source Accepted light, 1–3,
1–4

O

operation

electrical, 1–4

manual, 1–2

illustration of, 1–2

warning, 1–2

sequence of

see *Controller User's Guide*

optional accessories

see *Controller User's Guide*

P

parts, 2–1

phase rotation check, 1–3

problem, 2–2

R

rating label, cover

replacement parts, 2–1

S

service, 2–2

settings

see *Controller User's Guide*

T

test, functional, 1–2, 1–3, 1–4

time delays, 2–2

see *Controller User's Guide*

Transfer Control selector switch

Retransfer Delay Bypass, 1–4

Transfer Test, 1–4

*Transfer Switch Connected to
Emergency* light, 1–3, 1–4

*Transfer Switch Connected to
Normal* light, 1–3, 1–4

transfer test, 1–4

transfer to emergency, 1–4

transfer to normal, 1–4

trouble-shooting, 2–2

V

voltage checks, 1–3

voltage, pickup and dropout settings
see *Controller User's Guide*