

# 5100 SERIES Quad-Ethernet Module

## Installation & User's Manual

381333-459 B  
12/2019

## Catalog 5140 Accessory 72EE for ASCO Transfer Switches with Group G controller



## Catalog 5170 Accessory 72EE2 for ASCO Transfer Switches Group 5 controller

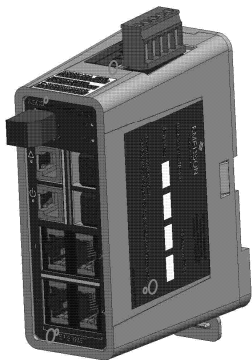

# Table of Contents

Glossary of Abbreviations and Terms.....	4
Introduction .....	5
Purpose of This Manual .....	5
General Specifications .....	5
5170 QEM Startup Checklist for 7000 Series Transfer Switch.....	6
5170 QEM Startup Checklist for 4000 Series Non-Bypass Transfer Switch .....	7
5140 QEM Startup Checklist for 4000 Series Bypass Transfer Switch .....	8
5140 QEM Startup Checklist for 300 Series Transfer Switch.....	9
Quick Start Guide.....	10
Mounting.....	10
Controller and Metering Connections .....	10
Ethernet Connections .....	11
Operational Power .....	11
Computer Configuration .....	12
Accessing the QEM .....	13
Web Interface.....	15
User Requirements.....	15
Desktop and Mobile Device Viewing .....	15
Web Navigation.....	16
Configuration Screens.....	18
Address form and Passwords .....	18
How to Change a Password.....	19
Connecting to Monitored Equipment.....	19
Connecting to ASCO Transfer Switch Controller .....	19
Connecting to Group 5 Controller(5170 QEM Only) .....	20
Connecting to Group G Controller.....	21
Connecting to Group H Controller .....	22
Connecting to Bypass-Isolation Controller .....	23
Connecting to Ethernet-IO Module(s).....	23
Configuring IP Address, Name and Location of Ethernet-IO Module(s) .....	24
Configuring Bypass-Isolation Monitoring for Ethernet-IO Module .....	24
Enabling Output Controls .....	24
IO Name .....	24
Connecting to 5200 SERIES Power Metering (5210 DPM/5220 PMXp) .....	25
APAC Configuration .....	26
Device Configuration Screens .....	26
TCP/IP Configuration .....	28
Addresses.....	28

Enabling and Disabling Modbus/TCP and ASCOBusII/TCP .....	29
TCP/IP Modbus (for Monitoring Systems) .....	29
Accessing Modbus Data.....	29
IP Address .....	29
Device Address .....	29
Modbus Register .....	30
ASCOBusII / TCP Interface .....	31
Alerts .....	32
Email (SMTP) Interface .....	35
QEM Recipient Support.....	35
Email Configuration and Interface.....	35
SNMP Interface .....	36
QEM Support.....	36
SNMP Configuration and Interface .....	36
Remote Transfer Operation .....	37
Transfer/Re-Transfer Operation .....	37
Data Encryption .....	38
Updating Firmware .....	39
Resetting Configurations .....	40
Restore to Default (Reset from Embedded Webpage) .....	40
Reset Button.....	40
Restart (Power Cycle) .....	40
Troubleshooting.....	41
Status Lights (LEDs) .....	41
Web Pages are not accessible.....	41
Dashboard Screen .....	42
Events Screen .....	44
Details Screen for Controllers & BIC.....	44
Details Screen for 5200 SERIES Metering .....	44
About Screen.....	44
RS485 ASCOBus and Modbus(5170 QEM Only).....	45
Communication Address Form for 5140/5170 Quad-Ethernet Module (QEM) .....	46
Connecting 5170 QEM Drawing Diagrams .....	47
Connecting 5140 QEM Drawing Diagrams .....	50
Index.....	52

## Glossary of Abbreviations and Terms used in this manual

Abbreviation	Definition and explanation
Acc. 72EE	Accessory 72EE, designation for 5140 QEM when provided with TS
Acc. 72EE2	Accessory 72EE2, designation for 5170 QEM when provided with TS
AES	Advanced Encryption Standard
APAC	ASCO Power and Control; the internal network used inside certain ASCO equipment
ASCO	ASCO Power Technologies
ASCOBus	ASCOBus2, protocol used by ASCO monitoring systems
ATS, TS	Automatic Transfer Switch, Transfer Switch
BIC	Bypass-Isolation Controller
BMS	Building Management System
CMD	Command
CPMS	Critical Power Management System, ASCO 5700 or 5900 SERIES
DIN	35 mm standard metal rail for mounting the QEM
DPM	Digital Power Meter, ASCO 5210
E-IO	Ethernet-IO Module, ASCO 5112
Gateway	Software or a computer running software that enables two different networks to communicate
Group G	Controller used on ASCO Transfer Switches
Group H	Controller used on ASCO Transfer Switches
Group 5	Controller used on ASCO Transfer Switches
IS	Information System, group that manages the computers and networks for a business
IP	Internet Protocol, provides rules for sending and receiving data packets between nodes through the Internet
LAN	Local Area Net, is a computer network limited to a small area
MAC	Media Access Control, is a hardware ID number that uniquely identifies each device on a network
MIB	Management Information Base
Modbus	A serial communications protocol
Ping	A protocol used to determine the presence of a host on the Internet
PMXp	Power Manager, ASCO 5220
QEM	Quad-Ethernet Module, ASCO SERIES 5100, used to reference both the 5140 and 5170
RS485	Serial interface the 5170 QEM supports to third party remote monitoring systems
SCADA	Supervisory Control and Data Acquisition system
SMTP	Simple Mail Transport Protocol, used for sending e-mail over a network
SNMP	Simple Network Management Protocol, used for exchanging management information between network devices
Subnet Mask	A number that defines a range of IP addresses that can be used in a network
TCP	Transmission Control Protocol, verifies delivery of data packets
TRAP	SNMP notification from Agent to Manager
TTL	Internal serial connection used between 5170 QEM to a Group 5 transfer switch controller and/or 5200 SERIES metering

## Introduction

The ASCO 5100 SERIES Quad-Ethernet Modules (QEM) are a line of protocol gateways that provides users with communication interfaces to ASCO transfer switches, meters and input/output devices. There are two QEM models, the 5140 QEM (Accessory 72EE, P/N 987100-004) and 5170 QEM (Accessory 72EE2, P/N 987100-204). The modules shall henceforth be referred to as QEM in this manual and the specific module will be referred to as 5140 or 5170 depending on the application. They provide the following interfaces and capabilities:

- Embedded webpage with transfer switch annunciation, event logs and remote transfer capabilities
- Email notification for alert conditions
- Modbus TCP/IP interface
- SNMP with trap notifications
- Four port Ethernet switch functionality

## Purpose of this Manual

This manual should be used to assist individuals who:

- will install and configure a QEM
- will monitor an ASCO transfer switch using the QEM's embedded web pages.
- will monitor an ASCO transfer switch using the ASCOBus, Modbus and/or SNMP protocols over Ethernet TCP/IP
- will configure and receive status changes and alarms through Email notification.

If the QEM is provided as an accessory to an ASCO Transfer Switch (Accessory 72EE or 72EE2) refer to the transfer switch installation manual, controller user's guide, and wiring diagram.

## General Specifications

Voltage:	24 V DC nominal	Ports:	
Power Requirements:	1.7 W	2 (yellow stripe) for ASCO APAC devices	
Mounting:	DIN mount vertical	2 (purple stripe) for ASCO TTL devices (5170 only)	
Dimensions (L,H,W):	4" x 5" x 2" (4 cm, 11 cm, 10 cm)	4 (blue stripe) for Ethernet	
Ambient Temperature:	-4° F to 158° F (-20° C to +70° C)	1 (green stripe on the top) for RS485 (5170 only)	

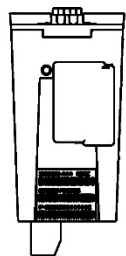

### OUTLINE DRAWING

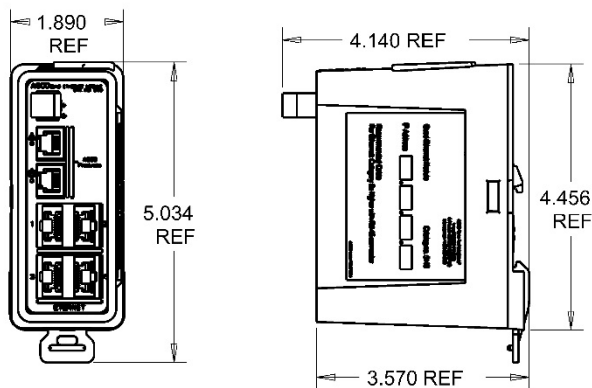

**5140 QEM**

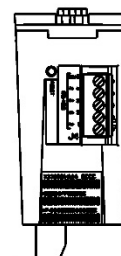

### OUTLINE DRAWING

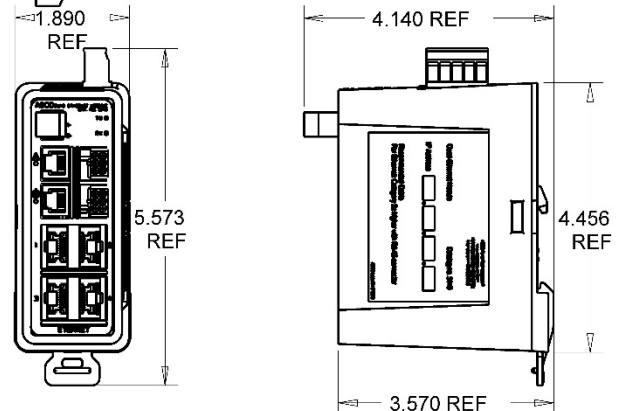

**5170 QEM**

## 5170 QEM Startup Checklist For 7000 Series Transfer Switch

For a QEM when mounted on a bypass or non-bypass transfer switch. This will describe the functions and equipment needed use a QEM.

<b>1</b>	<b>Connect Hardware</b> <ul style="list-style-type: none"> <li><input type="checkbox"/> Connect Group 5 Controller (Using TTL) <i>Page 47</i></li> <li><input type="checkbox"/> <i>Optional:</i> Connect 5210 DPM(s) (Using TTL and RS485) <i>Page 47</i></li> <li><input type="checkbox"/> <i>Optional:</i> Connect 5112 E-IO(s) (Using Ethernet) <i>Appendix Page 47</i></li> </ul>
<b>2</b>	<b>Configure Network Settings</b> <ul style="list-style-type: none"> <li><input type="checkbox"/> Configure QEM TCP/IP <i>Page 28</i></li> <li><input type="checkbox"/> <i>Optional:</i> Configure 5112 E-IO(s) <i>Page 23</i></li> </ul>
<b>3</b>	<b>Enable and Configure Devices</b> <ul style="list-style-type: none"> <li><input type="checkbox"/> Enable QEM for TTL/RS485 Communication <i>Page 19</i></li> <li><input type="checkbox"/> Enable Group 5 and Configure Device Name &amp; Location <i>Page 20</i></li> <li><input type="checkbox"/> <i>Optional:</i> Enable 5112 E-IO(s) and Configure Device Name &amp; Location <i>Page 23</i></li> <li><input type="checkbox"/> <i>Optional:</i> Enable DPM's and Configure Device Name &amp; Location <i>Page 25</i></li> </ul>
<b>4</b>	<b>Configure Alerts and E-IO</b> <ul style="list-style-type: none"> <li><input type="checkbox"/> Configure in TS Alerts Tile <i>Page 32</i></li> <li><input type="checkbox"/> <i>Optional:</i> Enable E-IO Monitoring of the Bypass-Isolation Switch <i>Page 24</i></li> <li><input type="checkbox"/> <i>Optional:</i> Change E-IO Name and Alerts <i>Page 24 &amp; 34</i></li> </ul>
<b>5</b>	<b>Configure Email</b> <ul style="list-style-type: none"> <li><input type="checkbox"/> <i>Optional:</i> Configure for ASCO's Internet Service or User's Network Email Server <i>Page 35</i></li> </ul>
<b>6</b>	<b>Configure Protocol</b> <ul style="list-style-type: none"> <li><input type="checkbox"/> <i>Optional:</i> Enable ASCOBus for ASCO Monitoring Systems <i>Page 29</i></li> <li><input type="checkbox"/> <i>Optional:</i> Enable Modbus <i>Page 29</i></li> <li><input type="checkbox"/> <i>Optional:</i> Configure TCP Ports for ASCOBus and Modbus <i>Page 29</i></li> <li><input type="checkbox"/> <i>Optional:</i> Enable and Configure SNMP <i>Page 36</i></li> </ul>
<b>7</b>	<b>Enable Remote Transfer</b> <ul style="list-style-type: none"> <li><input type="checkbox"/> <i>Optional:</i> Enable Transfer for Webpage <i>Page 37</i></li> <li><input type="checkbox"/> <i>Optional:</i> Enable Transfer for ASCO Monitoring Systems <i>Page 37</i></li> <li><input type="checkbox"/> <i>Optional:</i> Configure Selectable Failsafe Sequence Function and Timer <i>Page 37</i></li> </ul>

## 5170 QEM Startup Checklist For 4000 Series Non-Bypass Transfer Switch

For a QEM when mounted on a non-bypass transfer switch. This will describe the functions and equipment needed use a QEM.

### Connect Hardware

# 1

- Connect Group 5 Controller (Using TTL) *Page 47*
- Optional:* Connect 5210 DPM(s) (Using TTL and RS485) *Page 47*
- Optional:* Connect 5112 E-IO(s) (Using Ethernet) *Page 47*

### Configure Network Settings

# 2

- Configure QEM TCP/IP *Page 28*
- Optional:* Configure 5112 E-IO(s) *Page 23*

### Enable and Configure Devices

# 3

- Enable QEM for TTL/RS485 Communication *Page 19*
- Enable Group 5 and Configure Device Name & Location *Page 20*
- Optional:* Enable 5112 E-IO(s) and Configure Device Name & Location *Page 23*
- Optional:* Enable DPM's and Configure Device Name & Location *Page 25*

### Configure Alerts and E-IO

# 4

- Configure in TS Alerts Tile *Page 32*
- Optional:* Change E-IO Name and Alerts *Page 24 & 34*

### Configure Email

# 5

- Optional:* Configure for ASCO's Internet Service or User's Network Email Server *Page 35*

### Configure Protocol

# 6

- Optional:* Enable ASCOBus for ASCO Monitoring Systems *Page 29*
- Optional:* Enable Modbus *Page 29*
- Optional:* Configure TCP Ports for ASCOBus and Modbus *Page 29*
- Optional:* Enable and Configure SNMP *Page 36*

### Enable Remote Transfer

# 7

- Optional:* Enable Transfer for Webpage *Page 37*
- Optional:* Enable Transfer for ASCO Monitoring Systems *Page 37*
- Optional:* Configure Selectable Failsafe Sequence Function and Timer *Page 37*

## 5140 QEM Startup Checklist For 4000 Series Bypass Transfer Switch

For a QEM when mounted on a bypass transfer switch. This will describe the functions and equipment needed use a QEM.

<b>1</b>	<b>Connect Hardware</b> <ul style="list-style-type: none"> <li><input type="checkbox"/> Connect Group H Controller (Using APAC) <i>Page 50</i></li> <li><input type="checkbox"/> Connect BIC (Using APAC) <i>Page 50</i></li> <li><input type="checkbox"/> <i>Optional:</i> Connect 5210 DPM(s) (Using APAC) <i>Page 50</i></li> <li><input type="checkbox"/> <i>Optional:</i> Connect 5112 E-IO(s) (Using Ethernet) <i>Page 50</i></li> </ul>
<b>2</b>	<b>Configure Network Settings</b> <ul style="list-style-type: none"> <li><input type="checkbox"/> Configure QEM TCP/IP <i>Page 28</i></li> <li><input type="checkbox"/> <i>Optional:</i> Configure 5112 E-IO(s) <i>Page 23</i></li> </ul>
<b>3</b>	<b>Enable and Configure Devices</b> <ul style="list-style-type: none"> <li><input type="checkbox"/> Enable QEM for APAC Communication <i>Page 19</i></li> <li><input type="checkbox"/> Configure Group H Device Name &amp; Location <i>Page 22</i></li> <li><input type="checkbox"/> Configure BIC Device Name &amp; Location <i>Page 23</i></li> <li><input type="checkbox"/> <i>Optional:</i> Enable 5112 E-IO(s) and Configure Device Name &amp; Location <i>Page 23</i></li> <li><input type="checkbox"/> <i>Optional:</i> Enable DPM's and Configure Device Name &amp; Location <i>Page 25</i></li> </ul>
<b>4</b>	<b>Configure Alerts and E-IO</b> <ul style="list-style-type: none"> <li><input type="checkbox"/> Configure in TS Alerts Tile <i>Page 32</i></li> <li><input type="checkbox"/> Configure in BIC Alerts Tile <i>Page 33</i></li> <li><input type="checkbox"/> <i>Optional:</i> Change E-IO Name and Alerts <i>Page 34</i></li> </ul>
<b>5</b>	<b>Configure Email</b> <ul style="list-style-type: none"> <li><input type="checkbox"/> <i>Optional:</i> Configure for ASCO's Internet Service or User's Network Email Server <i>Page 35</i></li> </ul>
<b>6</b>	<b>Configure Protocol</b> <ul style="list-style-type: none"> <li><input type="checkbox"/> <i>Optional:</i> Enable ASCOBus for ASCO Monitoring Systems <i>Page 29</i></li> <li><input type="checkbox"/> <i>Optional:</i> Enable Modbus <i>Page 29</i></li> <li><input type="checkbox"/> <i>Optional:</i> Configure TCP Ports for ASCOBus and Modbus <i>Page 29</i></li> <li><input type="checkbox"/> <i>Optional:</i> Enable and Configure SNMP <i>Page 36</i></li> </ul>
<b>7</b>	<b>Enable Remote Transfer</b> <ul style="list-style-type: none"> <li><input type="checkbox"/> <i>Optional:</i> Enable Serial Feature 17 in Group H Controller <i>Manual:381333-444</i></li> <li><input type="checkbox"/> <i>Optional:</i> Enable Transfer for Webpage <i>Page 37</i></li> <li><input type="checkbox"/> <i>Optional:</i> Enable Transfer for ASCO Monitoring Systems <i>Page 37</i></li> <li><input type="checkbox"/> <i>Optional:</i> Configure Selectable Failsafe Sequence Function and Timer <i>Page 37</i></li> </ul>

## 5140 QEM Startup Checklist For Series 300 Transfer Switch

For a QEM when mounted on a bypass transfer switch. This will describe the functions and equipment needed use a QEM.

### Connect Hardware

1

- Connect Group G Controller (Using APAC) *Page 50*
- Optional:* Connect 5210 DPM(s) (Using APAC) *Page 50*
- Optional:* Connect 5112 E-IO(s) (Using Ethernet) *Page 50*

### Configure Network Settings

2

- Configure QEM TCP/IP *Page 28*
- Optional:* Configure 5112 E-IO(s) *Page 23*

### Enable and Configure Devices

3

- Enable QEM for APAC Communication *Page 19*
- Configure Group G Device Name & Location *Page 21*
- Optional:* Enable 5112 E-IO(s) and Configure Device Name & Location *Page 23*
- Optional:* Enable DPM's and Configure Device Name & Location *Page 25*

### Configure Alerts and E-IO

4

- Configure in TS Alerts Tile *Page 32*
- Optional:* Change E-IO Name and Alerts *Page 34*

### Configure Email

5

- Optional:* Configure for ASCO's Internet Service or User's Network Email Server *Page 35*

### Configure Protocol

6

- Optional:* Enable ASCOBus for ASCO Monitoring Systems *Page 29*
- Optional:* Enable Modbus *Page 29*
- Optional:* Configure TCP Ports for ASCOBus and Modbus *Page 29*
- Optional:* Enable and Configure SNMP *Page 36*

### Enable Remote Transfer

7

- Optional:* Enable Serial Feature 17 in Group H Controller *Manual: 381333-400*
- Optional:* Enable Transfer for Webpage *Page 37*
- Optional:* Enable Transfer for ASCO Monitoring Systems *Page 37*
- Optional:* Configure Selectable Failsafe Sequence Function and Timer *Page 37*

## Quick-Start Guide

The quick-start guide will provide the user with the information to establish a hardware connection, energize, and conduct the initial login to the QEM.

The QEM provides Ethernet access that allows users to view data from ASCO Transfer Switches, 5200 SERIES Power Metering and/or 5112 Ethernet-IO Modules. All users must follow these precautions:



To avoid possible shock, burns, or death, de-energize all electrical sources to the Transfer Switch before installing the 5100 SERIES Quad-Ethernet Module.



Be sure that *Users* to whom you give access are those persons that you want to view information about and/or control the electrical system.

### Mounting

The QEM mounts on a standard 35 mm DIN rail and when ordered as an accessory on an ASCO transfer switch will come mounted and wired. To release QEM from the DIN rail, pull down on the release handle at the bottom of the accessory (Figure 1).

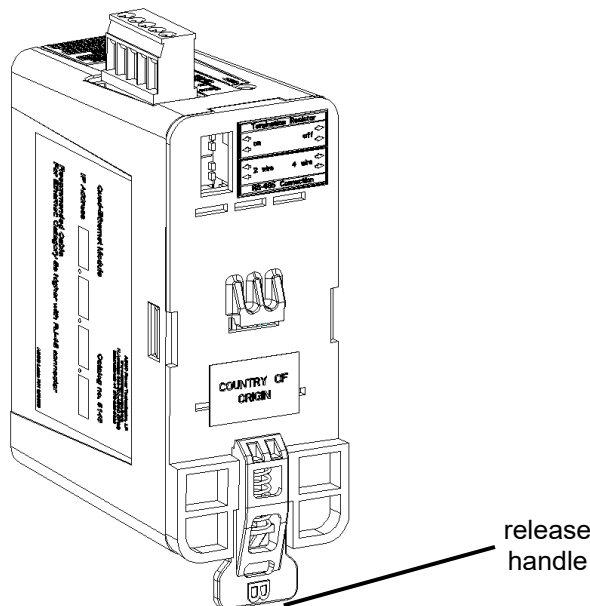

Figure 1. QEM release handle location

### Controller and Metering Connections

Both QEM models can support (1) transfer switch controller, (1) bypass-isolation controller, up to (2) Ethernet-IO Modules and up to (4) 5200 SERIES Meters.

The 5140 is compatible with Group G or H controllers, Bypass-Isolation Controller, and /or 5210 Digital Power Meters using APAC. The APAC ports are highlighted by a yellow strip and will connect all devices in a daisy chain.

		TS Controller	Bypass-Isolation	Meter 1	Meter 2	Meter 3	Meter 4
5140	Monitored Device	Group G or Group H	BIC	DPM	DPM	DPM	DPM
	Connection Type	APAC	APAC	APAC	APAC	APAC	APAC
	Default Device Serial Address	16	4	20	21	22	23

The 5170 QEM is used to connect to a Group 5 Controller and any accompanying 5210 Digital Power Meters (DPM) and 5220 Power Manager Xp (PMXp) via TTL and/or RS485. The TTL ports are highlighted by a purple strip and will be connected by a direct connection to the Group 5 controller and a single DPM or PMXp. The RS485 port is highlighted by a green strip and will be connected by a multi-drop to a single or multiple DPM's or PMXp's. The TTL and RS485 connections can be used simultaneously but using the RS485 for monitoring the meters will inhibit using the port for communication to a monitoring system.

		TS Controller	Bypass-Isolation	Meter 1	Meter 2	Meter 3	Meter 4
5170	Monitored Device	Group 5	E-IO	DPM or PMXp	DPM or PMXp	DPM or PMXp	DPM or PMXp
	Connection Type	TTL	Ethernet	TTL	RS485	RS485	RS485
	Default Device Serial Address	1	1	1	2	3	4

Both QEM models support the Ethernet-IO through an Ethernet connection. The Ethernet port is highlighted by a blue strip and will be connected by a direct connection to E-IO(s) or an Ethernet multi-drop to two E-IO(s).

### Operational Power

The module may be powered from either a connected Transfer Switch Controller, Group G or H (using APAC) or Group 5 (using TTL), connected 5200 SERIES Power Metering (using TTL or APAC) or from a remote 24VDC source (9 to 32 VDC). By energizing one of these sources, the module receives operational power and is accessible.

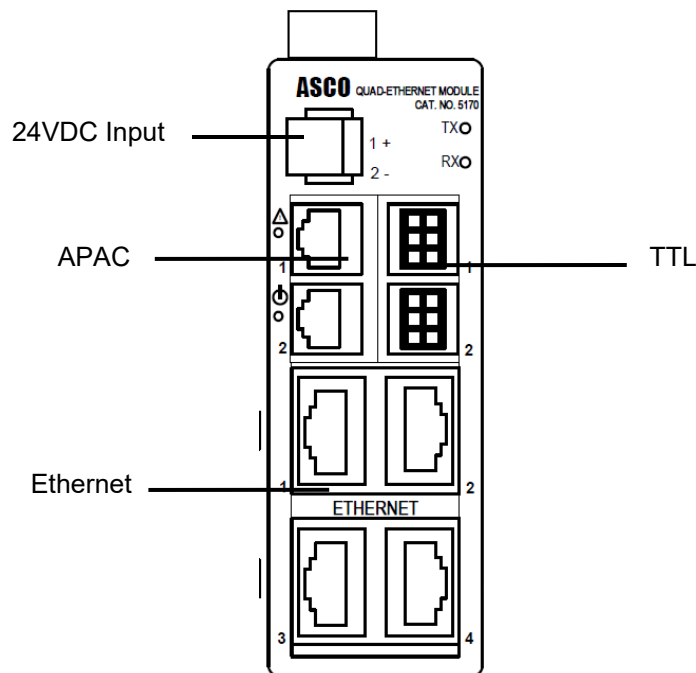

Figure 2. Ethernet an Operational Power Connections

### Ethernet Connections

Connect the Ethernet network to the lower ports with the blue stripe (Figure 2). Use Category 5e or higher cables with RJ-45 connectors. The QEM functions as an Ethernet switch and connecting to any port is acceptable. It is recommended to establish the Ethernet connection outside of the equipment prior to energizing internal components. When configuring a QEM a direct Ethernet connection from a computer to a single QEM is recommended. Placing multiple QEM's on a network with the same factory default IP will cause a communication failure on at least one unit, possibly multiple units.

## ⚠ WARNING

### POTENTIAL COMPROMISE OF SYSTEM AVAILABILITY, INTEGRITY, AND CONFIDENTIALITY

- Change default passwords to help prevent unauthorized access to device settings and information.
- Disable unused ports/services and default accounts to help minimize pathways for malicious attackers.
- Place networked devices behind multiple layers of cyber defenses (such as firewalls, network segmentation, and network intrusion detection and protection).
- Use cybersecurity best practices (for example, least privilege, separation of duties) to help prevent unauthorized exposure, loss, modification of data and logs, or interruption of services.
- All programming software should be kept in secured locations and should never be installed in or connected to any network other than the network for which the software is intended.
- All methods of mobile data exchange with the isolated network such as CDs, USB drives, etc. should be scanned before use.
- Laptops and other digital equipment that have connected to any other network besides the intended network should never be allowed to connect to the safety or control networks without proper sanitation.
- Minimize network exposure for all control system devices and/or systems, and ensure that they are not accessible from the Internet.
- When remote access is required, use secure methods, such as Virtual Private Networks (VPNs), recognizing that VPNs should be updated to the most current version available. Also recognize that VPN is only as secure as the connected devices.
- Communication protocols are accessible on a network, therefore best practices should be used to transfer sensitive information and to prevent unauthorized access.

**Failure to follow these instructions can result in death, serious injury, equipment damage or loss of sensitive data.**

## Computer Configuration

The default IP address of a QEM is **169.254.1.1**. For initial startup, a direct connection from a computer to a single QEM is recommended. The computer needs to have a static IP address assigned by the operator. For example, using a Windows based PC; the user will go into “Network Connections” and choose the option for adapter settings. Right click on the port for the Ethernet connection and select properties (Figure 3).

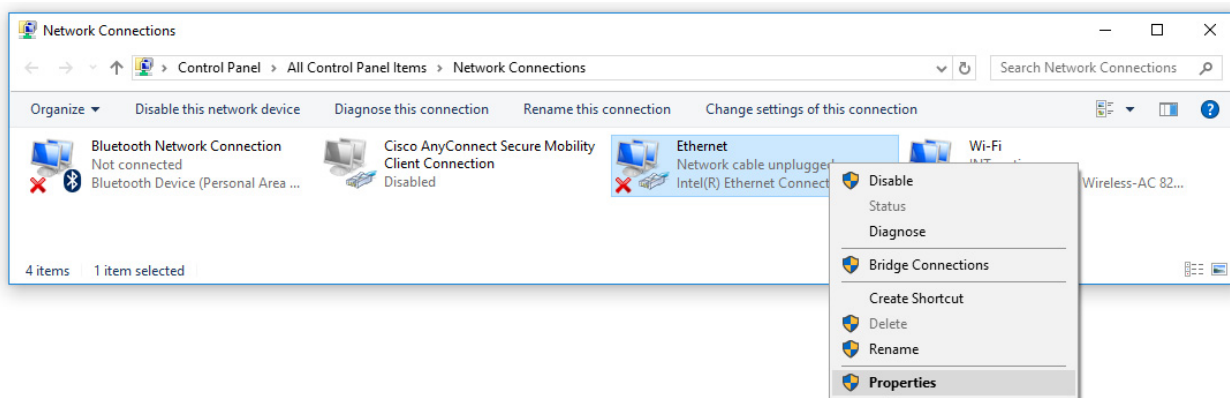

Figure 3. Network Connections Screen

From these options, select “Internet Protocol Version 4” and click properties (see Figure 4). Select button “Use the following IP address” to enter the IP address into the IP address field. The user should change the computer’s IP address to 169.254.1.100 and Subnet to 255.255.0.0 as shown in the example below. (See Figure 5).

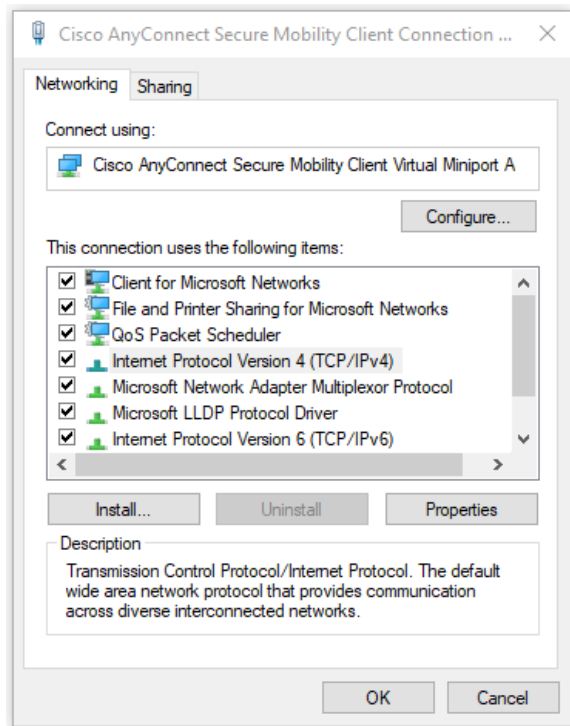

Figure 4. Networking Tab

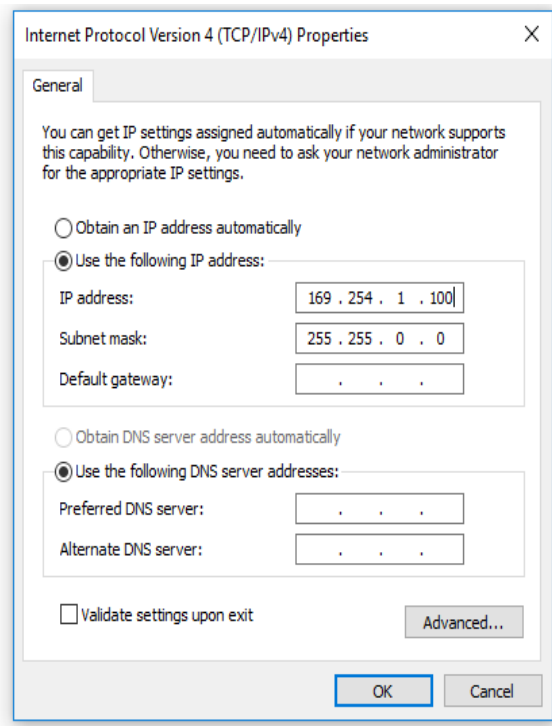

Figure 5. General Tab

## Accessing the QEM

Enter the default IP address of **169.254.1.1** into your web browser’s address field. This will open to the user login page (Figure 6).

Enter the default credentials to access the module

Username: admin

Password: ASCO

(username and password are case sensitive).



USER LOGIN

**Username**

**Password**

Copyright © ASCO Power Technologies. All rights reserved.

Figure 6. User Login Page

For security purposes, after the initial login, the user is prompted to enter a new password other than the default password. When the Change User Password screen appears, the new password must be 4 to 15 characters, and a combination of a-z, A-Z, and 0-9 (Figure 7).

**CHANGE USER PASSWORD**

Username

Old Password

New Password

Confirm New Password

Figure 7. Change User Password Screen

When the correct username and password is entered the Dashboard Screen (Figure 8) will appear.

DASHBOARD
EVENTS ▾
DETAILS ▾
CONFIGURATION ▾
ABOUT

English ▾
Logout

Name: ATS  
Location: Facility

Normal  
Acceptable

Load  
On Normal

Emergency  
Acceptable

118 Vca  
60.0 Hz  
0 A  
0 kW

117 Vca  
60.0 Hz

Load on N

ALARM STATUS	
No Active Alarm	

STATISTICS	VALUE
Total Transfers	28
Transfers Due to Source Failure	0
Total Number of Days Panel Energized	108
Time Normal Available	106d 23h 30m
Time Emergency Available	106d 23h 30m

VOLTAGE L-L	NORMAL	EMERGENCY
Vca (Volts)	118	117

Name: Meter 1 Location: Facility

POWER	SYSTEM	A	B	C
KW	0	0	0	0
KVA	0	0	0	0
KVAR	0	0	0	0
Power Factor	0.00	0.00	0.00	0.00
Frequency (Hz)	0.0	--	--	--

ENERGY	NORMAL	EMERGENCY
KW Hour Import	0	0
KW Hour Export	0	0
KW Hour Net	0	0

MAX WATTS DEMAND	VALUE
Max. Demand (kW)	47
Max. Demand Date	00/23/2015
Max. Demand Time	05:32
In Last Hour (kW)	0
In Last Day (kW)	0
In Last Month (kW)	0
In Last Year (kW)	0
Demand Interval (min)	1

Figure 8. Dashboard Screen

# Webpage Interface

The QEM has embedded web pages that allow the user to monitor connected ASCO transfer switches and metering. A computer or mobile device (smart phones and tablets) and a connection to the QEM over Ethernet will give the user access to data.

## User Requirements

- The user has a computer or web-enabled mobile device that has been configured to communicate over a network to the QEM. The setup can be viewed in the startup and configuration areas of this manual.
- The user has been provided the IP address of the QEM as well as a User Name and Password for access. It is possible that the information is still the default settings but may have been changed during setup.
- The user's web browser needs to be one supported by the QEM. The QEM supports Google's Chrome, Mozilla's Firefox, Microsoft's Internet Explorer and Apple's Safari internet browsers.

## Desktop and Mobile Device Viewing

The QEM will dynamically adjust the view of the embedded web page based on the resolution of the device, reorganizing the layout and removing the need for any side scrolling. The navigation will be affected with the change from desktop to mobile. The desktop view (Figure 9) shows the navigation on the top of the screen below the ASCO logo. Mobile Device view (Figure 10) will have a menu icon on the upper-left of the screen which allows for navigation. As shown below in the landing dashboard page for the QEM.

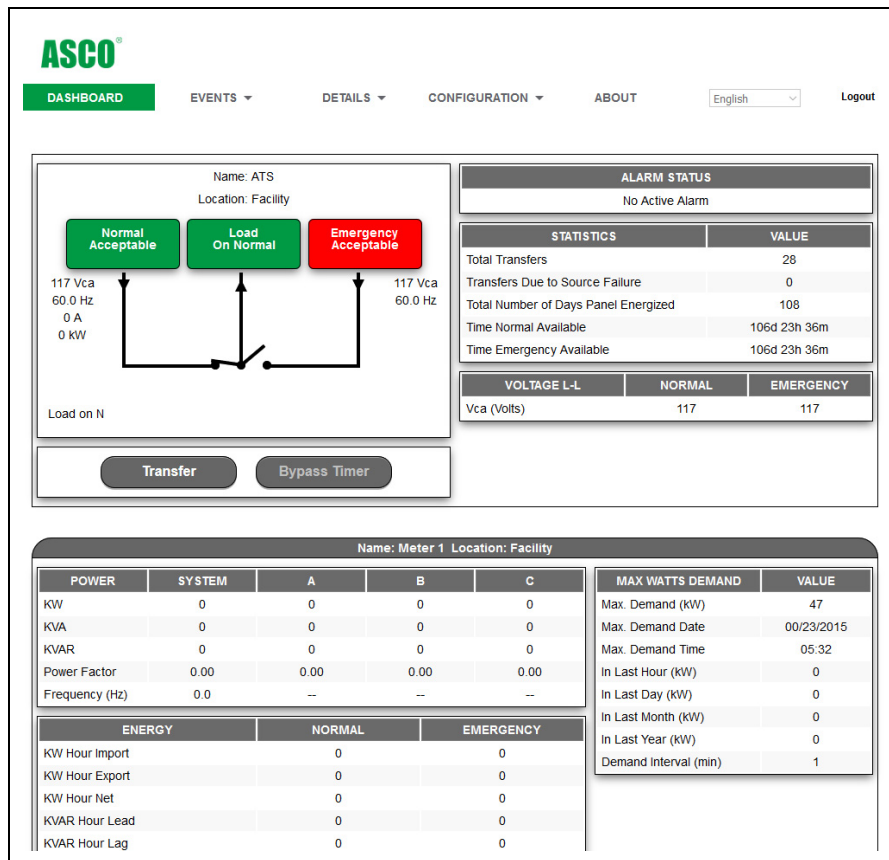

Figure 9. Desktop View Dashboard page

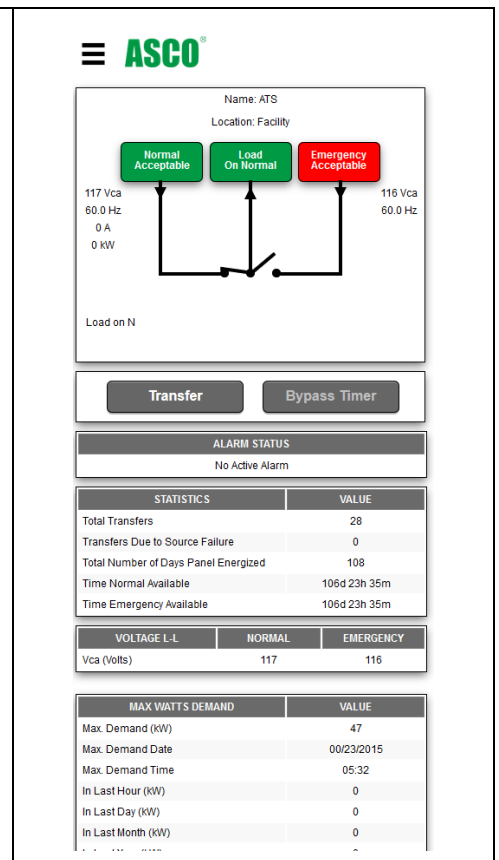

Figure 10. Mobile Device View Dashboard page

## Webpage Navigation

After the user has successfully logged in, the QEM Dashboard screen will appear. The navigation menu (Figure 11) represents the configured equipment showing the controller(s), E-IO module(s) and meter(s) in the dropdowns of the Details, Events and Configuration screens.

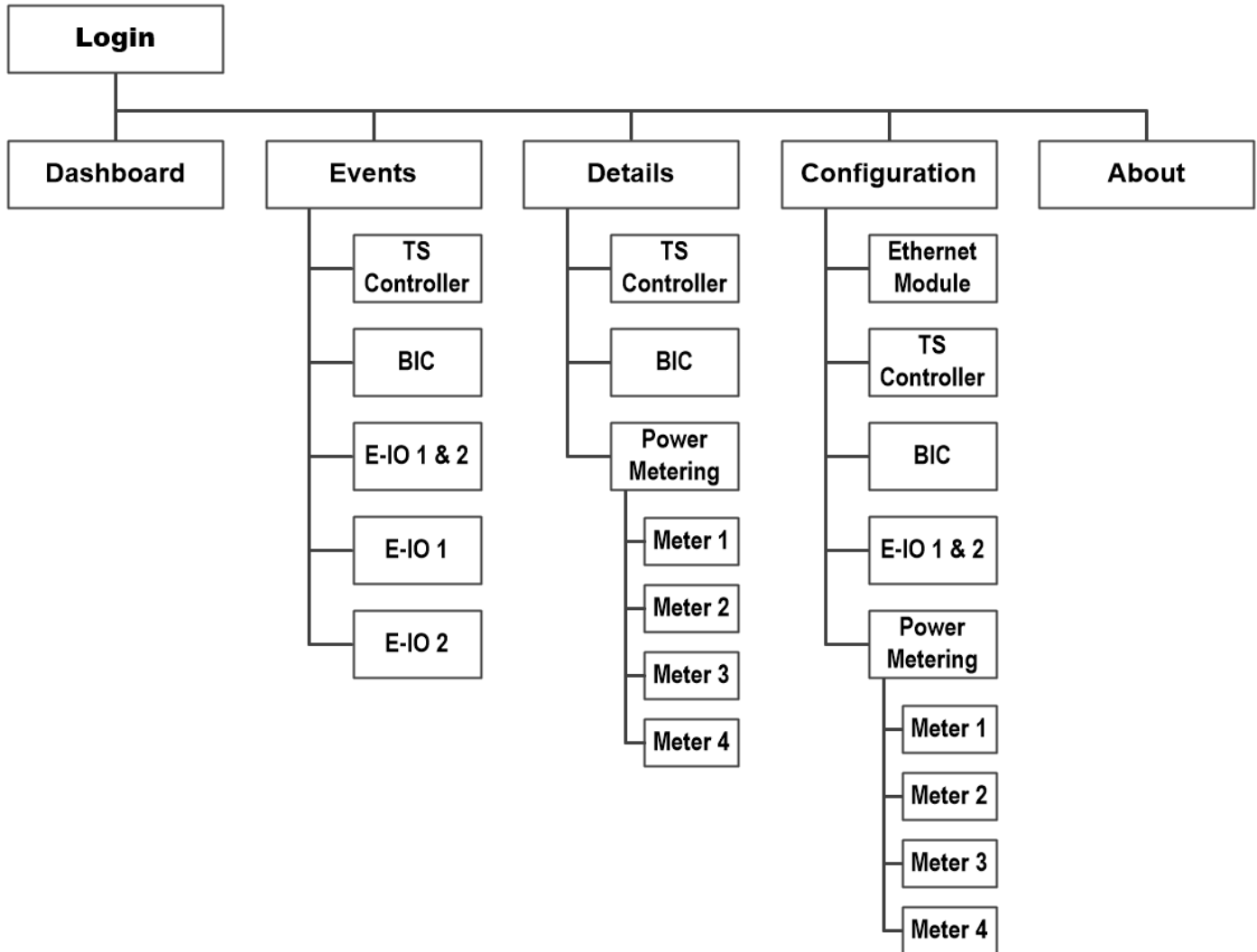

Figure 11. Navigation Menu-bar and drop-down boxes.

The presentation of the navigation function between the desktop and the mobile views will differ. The desktop navigation bar (Figure 12), below the header, features the selection of the main categories with the respective dropdown for the subcategories when the mouse hovers over the selection.



Figure 12. Desktop Navigation bar

The mobile view menu (Figure 13) is accessible from an icon on the upper left corner. Upon clicking the menu icon, the menu slides from the left with all the main categories and subcategories available for selection. The current page whether in desktop or mobile view will be highlighted in green.

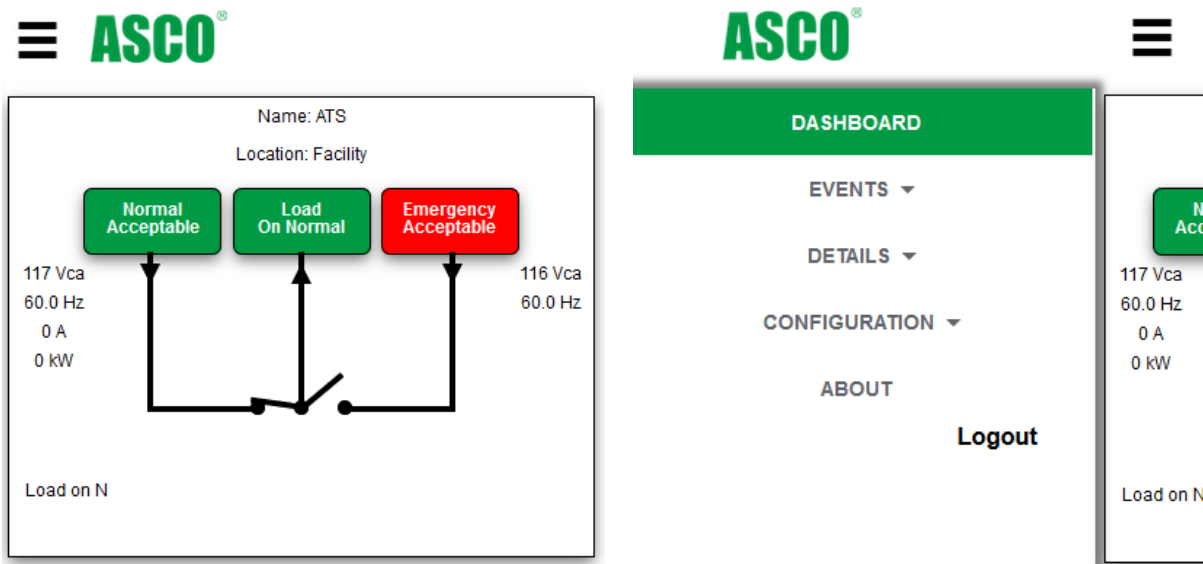

Figure 13. Mobile View Navigation.

## Configuration Screens

The Configuration screens (Figure 14) have a view only mode and an edit mode which is only accessible by an admin level user. There will be a configuration screen for the module setting as well separate screen for the controller and/or 5200 SERIES Metering. The functionality of the configuration screen will be discussed in a later section.

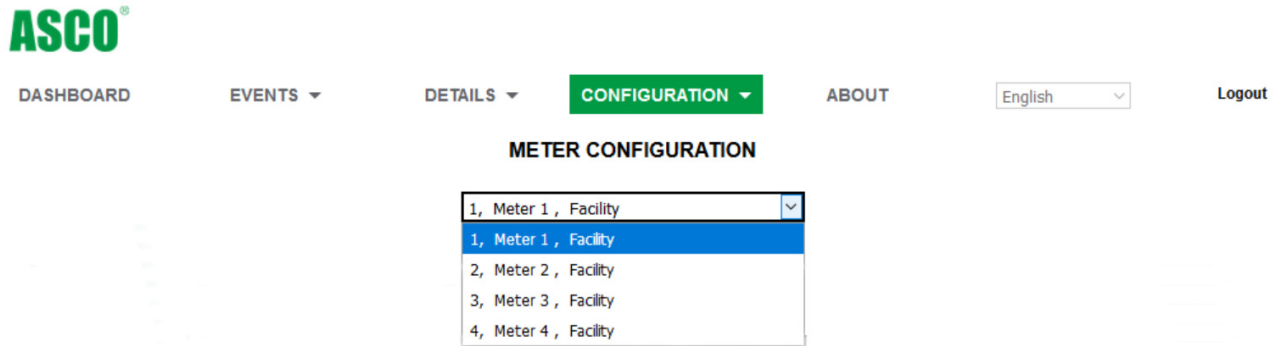

Figure 14. Meter Configuration screen with Dropdown options

After any changes are made to the configuration page, click the **SAVE** button. These changes will be saved and the webpage will revert to the *view* page. For security purposes, after 3 minutes of inactivity, the user will be automatically logged out.

**Note: The Edit mode allows only one user login at a time. During an admin's user edit session, other users will not have access to the QEM web page until the edit session is complete.**

## Access Levels and Passwords

The QEM has three different levels of web page user access privileges. The importance of these levels varies based on the interface method that is selected. The QEM is shipped with three preset usernames and default passwords. The three usernames cannot be changed. All three passwords can be changed by the **admin** level user. All three users (monitor, control, admin) can change their own password.

All QEM default passwords for different access levels must be changed upon initial login. When the Change User Password screen appears, the new password must be 8 to 16 characters in length, and be a combination containing at least one each of the following: a-z, A-Z, 0-9 and special characters (-= \, ;, / ~ ! @ # \$ % ^ & \* ( ) \_ + { } | : < > ?). Choose a password that is easy to remember but hard to guess.

If a user enters a wrong password three times, that username is locked out for three minutes.

Should access credentials be lost for the QEM, refer to section Reset Button on page 41 for resetting procedure.

Username (lower case) cannot be changed	Access Level	Default Password (upper case)
<b>monitor</b>	View access: can only view status and webpages, and change monitor password.	ASCO
<b>control</b>	Control access: in addition to monitor privileges, control users can transfer, retransfer and bypass time delays if control has been enabled by the administrator.	ASCO
<b>admin</b>	Full access: in addition to control and monitor privileges, admin users can set passwords, upgrade firmware, change QEM and other various settings.	ASCO

### NOTICE

**Be sure that users to whom you give control access are those persons that you want to be able to control the electrical system.**

## How to Change a Password

While in *Edit Mode* for the Configuration Screen, select the Advanced tab and click the **Change User Password** button. In the **Change User Password** window (Figure 15), type the *Username* (admin), the *Old password*, the *New password*, and *Confirm New Password*. Then click **Save**, and a message should indicate that the password was changed. Passwords will also be resettable from the hard-reset button located on the module hardware itself.

Type **monitor**, **control**, or **admin** (lower case).

Figure 15. Change User Password Screen

## Connecting to Monitored Equipment

This section discusses required configuration for QEM to enable communication to the ASCO controller, Ethernet-IO and/or 5200 SERIES Power Meter.

To configure the connected equipment, go to the Ethernet Module Configuration Screen in Edit Mode and select the Device List tab.

### Connecting to ASCO Transfer Switch Controller

If present and connected the QEM will automatically connect to an ASCO Group 5, Group H or Group G controller with factory default address configurations. The auto-selected connection of TTL/RS485 for Group 5 Controller or APAC for Group H or G Controller will be appropriately selected (Figure 16). The 5140 supports Group H or G through an APAC connection. The Enable checkbox will be enabled by default and the type of either “Group 5” or “Group G/H” can be selected or will auto-populate if a controller is found. When selected manually the box can appear as a check. It is recommended that the user manually select a box after auto-selection to retain the configuration to prevent interruption in communication for a rescan condition.

TCP/IP Alias Address					
Enable	Type	Modbus	Ascobus	Name	Actual address
<input checked="" type="checkbox"/>	Group 5	1	1	Name	1
<input type="checkbox"/>		2	1		1
<input type="checkbox"/>		3	2		2
<input type="checkbox"/>		4	3		3
<input type="checkbox"/>		5	4		4
<input type="checkbox"/>		6	5		5

Figure 16. Device Connection Screen with the APAC auto selected.

### Connecting to Group 5 Controller (5170 QEM Only)

When connected to a Group 5 controller, the 5170 will detect and populate all the screens and provide monitoring over open protocols parameters provided that the Group 5 is set to the default connection. If settings have been changed on the controller then manual configuration will be necessary. Device Detection is required to be set to "TTL/RS485" (Figure 17).

The Group 5 controller ships with a following factory default configuration:

Protocol: 19.2k (ASCOBusII protocol setting)  
 Serial Address: 1

The Group 5 protocol is required to be set to ASCOBusII to communicate to the 5170. The QEM can be configured to match a non-default Group 5 serial address in the "Actual Address" column but it is recommended that the QEM and controller be set to the default address. Refer to *Group 5 Controller User's Guide* 381333-126.

**DEVICE CONNECTION**

Device Detection:  TTL/RS485  APAC  
TTL device found, please save

TCP/IP Alias Address

Enable	Type	Modbus		Ascobus	Name	Actual address
1	<input checked="" type="checkbox"/> Group 5	1		1	Name	1
2	<input type="checkbox"/> Group 5	2		1		1
3	<input type="checkbox"/> Group G/H	3		2		2
4	<input type="checkbox"/> ▼	4		3		3
5	<input type="checkbox"/> ▼	5		4		4
6	<input type="checkbox"/> ▼	6		5		5

Figure 17. Device Connection Screen with the Group 5 configured.

## Connecting to Group G Controller

When connected to a Group G controller the QEM (5140 or 5170) will automatically detect and populate all the screens and provide monitoring over open protocols parameters. If controller settings have been changed on the from defaults, then manual configuration will be necessary. The Device Detection is required to be set to “APAC” (Figure 18).

The Group G controller ships with the following non-configurable setting:

Serial Address: 16

The serial address of the QEM is configurable to match the controller address in the column labelled “Actual Address”. Refer to *Group G Controller User’s Guide* 381333-400.

**DEVICE CONNECTION**

Device Detection:     TTL/RS485     APAC  
APAC device found, please save

		TCP/IP Alias Address				
Enable	Type	Modbus	Ascobus	Name	Actual address	
1	<input checked="" type="checkbox"/> Group G/ ▾	1	1	<input type="text" value="Name"/>	16	
2	<input type="checkbox"/> Group 5	2	1	<input type="text"/>	0	
3	<input type="checkbox"/> Group G/H	3	2	<input type="text"/>	0	
4	<input type="checkbox"/> ▾	4	3	<input type="text"/>	0	
5	<input type="checkbox"/> ▾	5	4	<input type="text"/>	0	
6	<input type="checkbox"/> ▾	6	5	<input type="text"/>	0	

Figure 18. Device Connection Screen with Group G configuration.

### Connecting to Group H Controller

When connected to a Group H controller the QEM (5140 or 5170) will automatically detect and populate all the screens and provide monitoring over open protocols parameters. If controller settings have been changed from defaults, then manual configuration will be necessary. The Device Detection is required to be set to “APAC” (Figure 19).

The Group H controller ships with the following non-configurable setting:

Serial Address: 16

The serial address of the QEM is configurable to match the controller address in the column labelled “Actual Address”. Refer to *User’s Guide* 381333-444.

**DEVICE CONNECTION**

Device Detection:     TTL/RS485     APAC

APAC device found, please save

TCP/IP Alias Address

	Enable	Type	TCP/IP Alias Address		Name	Actual address
			Modbus	Ascobus		
1	<input checked="" type="checkbox"/>	Group G/ ▾	1	1	Name	16
2	<input type="checkbox"/>	Group 5	2	1		0
3	<input type="checkbox"/>	Group G/H ▾	3	2		0
4	<input type="checkbox"/>	▾	4	3		0
5	<input type="checkbox"/>	▾	5	4		0
6	<input checked="" type="checkbox"/>	BIC ▾	6	5	Name	4

Figure 19. Device Connection Screen with Group H configuration.

## Connecting to Bypass-Isolation Controller

When connected to a Bypass-Isolation Controller, the QEM (5140 or 5170) will automatically detect and populate all the screens and provide monitoring over open protocols parameters. If controller settings have been changed from defaults, then manual configuration will be necessary. The Device Detection is required to be set to “APAC” (Figure 20).

The BIC ships with the following non-configurable setting:

Serial Address: 4

The serial address of the QEM is configurable to match the controller address in the column labelled “Actual Address”. Refer to *User’s Guide* 381333-444.

The screenshot shows the 'DEVICE CONNECTION' window. At the top, 'Device Detection' has two radio buttons: 'TTL/RS485' (unselected) and 'APAC' (selected). Below this, a green message reads 'APAC device found, please save'. The main section is a table titled 'TCP/IP Alias Address' with columns: 'Enable', 'Type', 'Modbus', 'Ascobus', 'Name', and 'Actual address'. There are six rows. Row 1 is checked and has 'Group G/' in the Type column, '1' in Modbus, '1' in Ascobus, 'Name' in Name, and '16' in Actual address. Row 6 is checked and has 'BIC' in the Type column, '6' in Modbus, '5' in Ascobus, 'Name' in Name, and '4' in Actual address. A dropdown menu is open for the 'BIC' entry, showing 'BIC' as the selected option. At the bottom are three buttons: 'Save', 'Cancel', and 'Default'.

	Enable	Type	Modbus	Ascobus	Name	Actual address
1	<input checked="" type="checkbox"/>	Group G/	1	1	Name	16
2	<input type="checkbox"/>		2	1		0
3	<input type="checkbox"/>		3	2		0
4	<input type="checkbox"/>		4	3		0
5	<input type="checkbox"/>		5	4		0
6	<input checked="" type="checkbox"/>	BIC	6	5	Name	4

Figure 20. Device Connection Screen with Group H configuration.

## Connecting to Ethernet-IO Module(s)

When connected to Ethernet-IO module(s) the user will be required to enable the E-IO by clicking that selection option. The QEM will detect if the E-IO is a 16 Input or 14 Input / 2 Output configuration.

Note: The IP Address for the QEM and the E-IO must be configured for the same TCP/IP network. If multiple E-IO are placed on the same network, the IP addresses for the E-IOs and/or the QEM must not match else it will result in a communication error. The IP address of the E-IO will be configured at the module itself and then the QEM must match that address.

The screenshot shows the 'ETHERNET-IO MODULE CONNECTION' window. It features a table with columns: 'Enable', 'Type', 'TCP/IP Alias Modbus Address', 'IP Address', and 'Name'. There are two rows. Row 1 has '9' in the Modbus Address column and '192.168.127.254' in the IP Address column. Row 2 has '10' in the Modbus Address column and '192.168.127.254' in the IP Address column. At the bottom are two buttons: 'Save' and 'Cancel'.

	Enable	Type	TCP/IP Alias Modbus Address	IP Address	Name
1	<input type="checkbox"/>		9	192.168.127.254	
2	<input type="checkbox"/>		10	192.168.127.254	

Figure 21. Ethernet-IO Module Connection Screen.

### Configuring IP Address, Name and Location of Ethernet-IO Module(s)

The user will also be required to enter the E-IO IP Address and optionally enter the name of the module (Figure 22) The E-IO will detect if the E-IO is a 16 Input or 14 Input / 2 Output configuration.

### Configuring Bypass-Isolation Monitoring for Ethernet-IO Module

When mounted on a Group 5 when a single E-IO is configured and connected for bypass monitoring the user can enable the monitoring of the bypass transfer switch which will change the first 8 inputs to predefined parameters for Email alert purposes and change the oneline to a transfer switch with a bypass isolation. (Figure 22)

### Enabling Output Controls

The QEM supports a maximum of (1) 14 Input / 2 Output modules. The two output contacts will be operable from the embedded webpage of the QEM but that functionality shall come factory disabled. To make the option to open and close the output contacts on the Dashboard screen the user will need to select "Enable Output Control". (Figure 22)

### IO Name

The QEM has default names for the IO points which are user configurable. Changing the names of the IO will be reflected on the Dashboard Screens and email notifications. (Figure 22)

**E-IO MODULE 1**

Name:

Location:

IP Address:

TCP Port:

Enable Bypass-Isolation Monitoring

E-IO	Enable Alert For	Name
I - 01	None ▼	<input type="text" value="Input 01"/>
I - 02	None ▼	<input type="text" value="Input 02"/>
I - 03	None ▼	<input type="text" value="Input 03"/>
I - 04	None ▼	<input type="text" value="Input 04"/>
I - 05	None ▼	<input type="text" value="Input 05"/>
I - 06	None ▼	<input type="text" value="Input 06"/>
I - 07	None ▼	<input type="text" value="Input 07"/>
I - 08	None ▼	<input type="text" value="Input 08"/>
I - 09	None ▼	<input type="text" value="Input 09"/>
I - 10	None ▼	<input type="text" value="Input 10"/>
I - 11	None ▼	<input type="text" value="Input 11"/>
I - 12	None ▼	<input type="text" value="Input 12"/>
I - 13	None ▼	<input type="text" value="Input 13"/>
I - 14	None ▼	<input type="text" value="Input 14"/>
I - 15	None ▼	<input type="text" value="Input 15"/>
I - 16	None ▼	<input type="text" value="Input 16"/>

Enable Output Control

Figure 22. Ethernet-IO Module Device Configuration.

## Connecting to 5200 SERIES Power Metering (5210 DPM / 5220 PMXp)

If the metering is paired with a controller, it must be connected to the QEM via the same connection type

1. APAC for the Group G and DPM
2. TTL/RS485 for the Group 5 and DPM or PMXp.

The TTL/RS485 configuration, whether standalone or mounted in a transfer switch, requires the meter(s) to be enabled and configured for the serial address or to match the serial address on the meter. The 5170 QEM accepts a connection from either a TTL or RS485 port and the correct meter port needs to be configured, either the TTL (SCI) or RS485 (Figure 23). Refer to *5210 Digital Power Meter Operator's Manual* 381333-368 and/or *5200 Series Power Manager XP Operator's Manual* 381333-199.

The default Actual Address(es):

- Serial Address: 1
- Serial Address: 2
- Serial Address: 3
- Serial Address: 4

**DEVICE CONNECTION**

Device Detection:  TTL/RS485  APAC

	Enable	Type	TCP/IP Alias Address		Name	Actual address
			Modbus	Ascobus		
1	<input checked="" type="checkbox"/>	Group 5	1	1	ATB	1
2	<input checked="" type="checkbox"/>	DPM	2	1	5210 DPM	1
3	<input type="checkbox"/>		3	2		2
4	<input type="checkbox"/>		4	3		3
5	<input type="checkbox"/>		5	4		4
6	<input type="checkbox"/>		6	5		5

Figure 23. Device Connection Screen with 5210 DPM configured for TTL/RS485

The DPM APAC configuration whether standalone or mounted on a transfer switch requires the DPM to be configured for the APAC address to work and enabled. Refer to *5210 Digital Power Meter Operator's Manual* 381333-368.

The default Actual Address(es):

- Serial Address: 20
- Serial Address: 21
- Serial Address: 22
- Serial Address: 23

**Note: The APAC address configured in the DPM will identify if monitoring Load, Normal, Emergency or Other.**

## APAC Configuration

APAC Bus Termination enables the termination resistor on the APAC data network. This setting is enabled by default and should be left enabled and should only be adjusted for trouble shooting (Figure 24). To configure the APAC Bus Termination, go to the Ethernet Module Configuration Screen in Edit Mode and select the APAC tab.

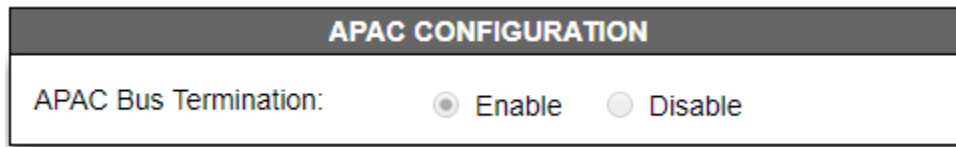

Figure 24. APAC Bus Termination Configuration

## Device Configuration Screens

Controller, BIC and Meter Configuration screens (Figures 25, 26 and 27) for the connected controllers and meters which will be available to change the name and location of the device. These are accessible by clicking on the Configuration drop down and selecting the Controller option.

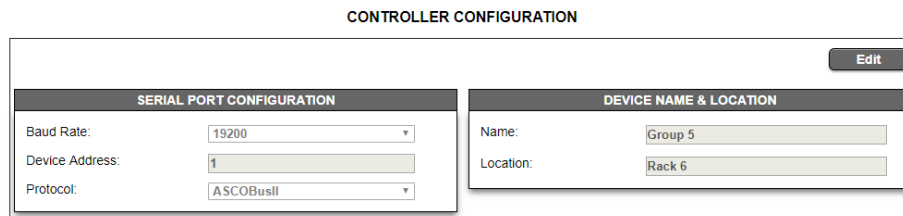

Figure 25. Controller Configuration

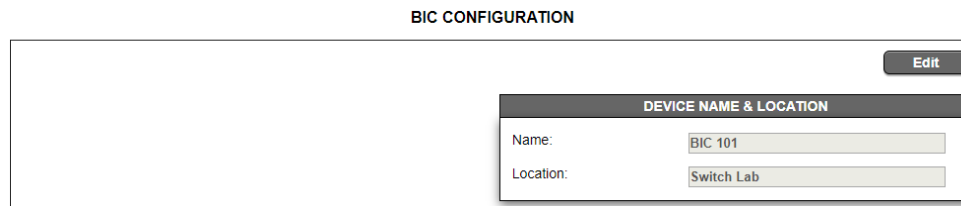

Figure 26. Controller Configuration

If the system is equipped with a PMXp, the Input & Output Names will also be configurable. This is accessible by clicking on the Configuration drop down and selecting the Meter option. If there are multiple meters, those are accessible from the dropdown embedded on the screen.

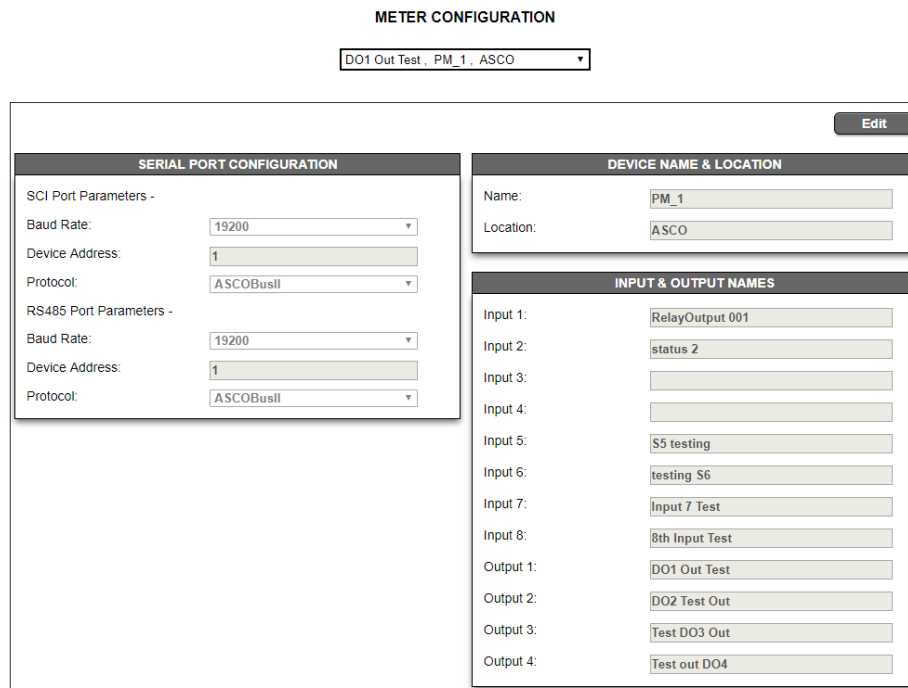

Figure 27. Meter Configuration

If the QEM is connected to an E-IO Module, additional configurations will need to be done through the details page.

**E-IO MODULE 1**

Name:

Location:

IP Address:

TCP Port:

Enable Bypass-Isolation Monitoring

E-IO	Enable Alert For	Name
I - 01	<input type="text" value="None"/> ▼	<input type="text" value="Input 01"/>
I - 02	<input type="text" value="None"/> ▼	<input type="text" value="Input 02"/>
I - 03	<input type="text" value="None"/> ▼	<input type="text" value="Input 03"/>
I - 04	<input type="text" value="None"/> ▼	<input type="text" value="Input 04"/>
I - 05	<input type="text" value="None"/> ▼	<input type="text" value="Input 05"/>
I - 06	<input type="text" value="None"/> ▼	<input type="text" value="Input 06"/>
I - 07	<input type="text" value="None"/> ▼	<input type="text" value="Input 07"/>
I - 08	<input type="text" value="None"/> ▼	<input type="text" value="Input 08"/>
I - 09	<input type="text" value="None"/> ▼	<input type="text" value="Input 09"/>
I - 10	<input type="text" value="None"/> ▼	<input type="text" value="Input 10"/>
I - 11	<input type="text" value="None"/> ▼	<input type="text" value="Input 11"/>
I - 12	<input type="text" value="None"/> ▼	<input type="text" value="Input 12"/>
I - 13	<input type="text" value="None"/> ▼	<input type="text" value="Input 13"/>
I - 14	<input type="text" value="None"/> ▼	<input type="text" value="Input 14"/>
I - 15	<input type="text" value="None"/> ▼	<input type="text" value="Input 15"/>
I - 16	<input type="text" value="None"/> ▼	<input type="text" value="Input 16"/>

Enable Output Control

Figure 28. Ethernet-IO Configuration

## TCP/IP Configuration

To integrate the QEM onto your network for remote access to the embedded webpages, Modbus, SNMP, and Email you will need to configure the Ethernet TCP/IP settings. To configure, go to the Ethernet Module Configuration Screen in Edit Mode and select the IPv4 tab

The **Ethernet TCP/IPv4** window includes these sub areas (Figure 29):

Enabling **DHCP** (Dynamic Host Configuration Protocol) mode allows the IP address of the QEM to be set by a DHCP server – usually as part of an IS administered network. This is rarely used due to the need for a network to be well defined, and is usually done using static IP addresses. In case DHCP is enabled, contact the network administrator for the assigned IP address and duration policies.

**Note: QEM requires DHCP functionality to be disabled to communicate with the Ethernet-IO.**

The **IP Address**, **Subnet Address** mask, and **Gateway Address** are network settings that will often be provided by the network manager. The default settings are 169.254.1.1, 255.255.0.0 and 0.0.0.0, respectively. Further information on changes to these settings should be addressed by the network manager.

The global **TCP** ports are used by BMS, SCADA and ASCO monitoring systems to access the data within the QEM. Both ports support ASCOBusII/TCP and Modbus/TCP when the protocols are enabled. TCP Port 1 will be default configured to 502, Modbus/TCP's standard port, and TCP Port 2 will be default configured to 10001, ASCOBusII/TCP's standard port. The end user will be able to configure the TCP port number to a non-standard number.

Figure 29. Ethernet TCP/IP v4 Configuration

### NOTICE

Leave settings as default when possible. Usually the IP Address is all that is required to be changed.

### Addresses

The MAC address and the factory default IP address are located on the outside of the QEM. Refer to the **About** webpage for determining the IP address and MAC address. Fill in MAC address in table below.

Address	Default Address	New Address
IP Address	169.254.001.001	
MAC Address	00:0C:99:____:____:____.	The MAC Address cannot be changed by the user

## Enabling and Disabling Modbus/TCP and ASCOBusII/TCP

On the Ethernet TCP/IPv4 tile, “Modbus TCP” is the parameter for Modbus/TCP protocol and “ASCO TCP” is the parameter for ASCOBusII/TCP protocol. Both Modbus/TCP and ASCOBusII/TCP functionally are default disabled on the QEM and needs to be enabled by the user. The user can individually select “Enable” or “Disable” to achieve the desired functionality (Figure 30).

### NOTICE

Communication protocols are accessible on a network, therefore best practices should be used to transfer sensitive information and to prevent unauthorized access.

The screenshot shows the 'ETHERNET TCP/IPv4' configuration window. It includes fields for DHCP Mode (set to Disable), IP Address (169.254.1.1), Subnet Address (255.255.0.0), and Gateway Address (0.0.0.0). Under 'Protocol Configuration', 'Modbus TCP' and 'ASCO TCP' are both set to 'Enable'. Below this are settings for TCP Port 1 (Port Number: 502, AES Mode: Disable) and TCP Port 2 (Port Number: 10001, AES Mode: Disable). 'Save' and 'Cancel' buttons are at the bottom.

Figure 30. IPv4 Screen showing the enabling of ASCOBus TCP

## Modbus/TCP (for Monitoring Systems)

The QEM can act as a Modbus server to provide data to a Modbus client on demand over TCP/IP Intranet. Because the QEM acts as a data concentrator, the data from devices are constantly updated and available in the QEM.

### Accessing Modbus Data

Accessing parameters by Modbus requires three settings over TCP/IP: the IP Address, the TCP Port device address, and the Modbus Register number.

#### IP Address

The IP Address is required to allow a master the ability to communicate to the QEM; this is defined in the configuration page of the QEM web server, TCP/IP Tile (Figure 30). The Modbus/TCP Client is on the same network as the Modbus/TCP server (the QEM).

#### TCP Ports

The TCP ports are default configured to the Modbus standard number of 502 & ASCOBus standard number of 10001. If a non-standard number is used the user can change this number.

## Device Address

The QEM maps the Modbus data using the TCP/IP *Alias* table to define the device addressing. This is the device address needed when configuring the Modbus client. To configure the connected equipment, go to the Ethernet Module Configuration Screen in Edit Mode and select the Device List tab. The Modbus Address parameters can be accessed under the TCP/IP Alias Address columns (Figures 31 and 32).

The Modbus address for the transfer switch controller, BIC, E-IO and/or 5200 SERIES Meters are default configured in the QEM as 1 through 6 but may be changed to meet site requirements.

DEVICE CONNECTION						
Device Detection: <input checked="" type="checkbox"/> TTL/RS485 <input type="checkbox"/> APAC						
TCP/IP Alias Address						
Enable	Type	Modbus	Ascobus	Name	Actual address	
<input checked="" type="checkbox"/>	Group 5	1	1	ATB	1	
<input checked="" type="checkbox"/>	DPM	2	1	5210 DPM	1	
<input type="checkbox"/>		3	2		2	
<input type="checkbox"/>		4	3		3	
<input type="checkbox"/>		5	4		4	
<input type="checkbox"/>		6	5		5	

Buttons: Save, Cancel, Default

Figure 31. Modbus Alias Address

ETHERNET-IO MODULE CONNECTION				
Enable	Type	TCP/IP Alias Modbus Address	IP Address	Name
<input type="checkbox"/>		9	192.168.127.254	
<input type="checkbox"/>		10	192.168.127.254	

Buttons: Save, Cancel

Figure 32. Modbus Alias Address

## Modbus Register

The Modbus register map is the same as that of the monitored devices. As an example, the line-to-line voltage (A-B) in the controller is at register address 40017. Reading this same register from the QEM will provide the data from the Controller to the Modbus client.

The TCP port setting is done on the Configuration/Ethernet Module page, ETHERNET TCP/IPv4 Tile. For an example interface using the *Modbus Test Suite* refer to document 381339-319.

## ASCOBus / TCP Interface

ASCOBus is a proprietary protocol designed by ASCO Power Technologies for use with ASCO 5700 & 5900 SERIES CPMS systems, 5300 SERIES Remote Annunciators and PCS Systems. Accessing ASCOBus data requires an ASCO Power Technologies technician.

ASCOBus functionality is default disabled on the QEM and needs to be enabled by the user. On the Ethernet TCP/IPv4 tile, for the parameter “ASCO TCP”, select “Enable” to allow an ASCO monitoring system to access the data or “Disable” remove that functionality.

To configure the connected equipment, go to the Ethernet Module Configuration Screen in Edit Mode and select the Device List tab. The ASCOBus Address parameters can be accessed under the TCP/IP Alias Address columns (Figure 33).

The ASCOBus address for the transfer switch controller and 5200 SERIES Meters are default configured in the QEM as 1 through 5 respectively but may be changed to meet site requirements (Figure 33).

**DEVICE CONNECTION**

Device Detection:  TTL/RS485  APAC

TCP/IP Alias Address

	Enable	Type	Modbus	Ascobus	Name	Actual address
1	<input checked="" type="checkbox"/>	Group 5 ▼	1	1	ATB	1
2	<input checked="" type="checkbox"/>	DPM ▼	2	1	5210 DPM	1
3	<input type="checkbox"/>	▼	3	2		2
4	<input type="checkbox"/>	▼	4	3		3
5	<input type="checkbox"/>	▼	5	4		4
6	<input type="checkbox"/>	▼	6	5		5

Figure 33. Modbus Alias Address

## Alerts

The alerts configurations affect the notification for email and SNMP. Any enabling or disabling affects all notification functions for that alert. The option for alerts tiles will vary depending on the monitoring of configured equipment.

To configure the connected equipment, go to the Ethernet Module Configuration Screen in Edit Mode and select the Alert tabs. The Modbus Address parameters can be accessed under the TCP/IP Alias Address columns. (Figures 30 and 31)

When the QEM is configured for monitoring a Transfer Switch controller the below screen will be available with the alerts selectable by checking the options. The QEM disables the selection of parameters based on the configuration of the controller (Figure 34).

TS ALERT NOTIFICATIONS	
<input checked="" type="checkbox"/>	Generator Start Signal Activated
<input checked="" type="checkbox"/>	Generator Start Signal Removed
<input checked="" type="checkbox"/>	Transferred from Normal to Emergency
<input checked="" type="checkbox"/>	Transferred from Emergency to Normal
<input checked="" type="checkbox"/>	Emergency Accepted
<input checked="" type="checkbox"/>	Emergency Not Accepted
<input checked="" type="checkbox"/>	Normal Accepted
<input checked="" type="checkbox"/>	Normal Not Accepted
<input type="checkbox"/>	Engine/Auxiliary Input Enabled
<input type="checkbox"/>	Loss of Emergency When on Emergency
<input type="checkbox"/>	Load Disconnected
<input type="checkbox"/>	Transfer Switch Changed to Non-Auto Mode
<input type="checkbox"/>	Transfer Switch Changed to Auto Mode
<input type="checkbox"/>	Emergency Not Accepted in Time
<input type="checkbox"/>	Transfer Not Successful
<input type="checkbox"/>	Transfer Position not Determined
<input type="checkbox"/>	Transfer Switch Locked out
<input type="checkbox"/>	CTTS Extended Parallel Alarm
<input type="checkbox"/>	CTTS Failure to Synchronize
<input type="checkbox"/>	Normal Breaker Tripped
<input type="checkbox"/>	Emergency Breaker Tripped
<input type="checkbox"/>	Y-Y Primary Fail is Active
<input type="button" value="Save"/> <input type="button" value="Cancel"/>	

Figure 34. Alert Configuration Screen

When the QEM is configured for monitoring a BIC the below screen will be available with the alerts selectable by checking the options.

BIC ALERT NOTIFICATIONS
<input checked="" type="checkbox"/> ATS Transferred to Normal Source
<input checked="" type="checkbox"/> ATS Transferred off Normal Source
<input checked="" type="checkbox"/> ATS Transferred to Emergency Source
<input checked="" type="checkbox"/> ATS Transferred off Emergency Source
<input checked="" type="checkbox"/> Bypassed to Normal Source
<input checked="" type="checkbox"/> Unbypassed from Normal Source
<input checked="" type="checkbox"/> Bypassed to Emergency Source
<input checked="" type="checkbox"/> Unbypassed from Emergency Source
<input checked="" type="checkbox"/> Normal Source has become Available
<input checked="" type="checkbox"/> Normal Source has become Not Available
<input checked="" type="checkbox"/> Emergency Source has become Available
<input checked="" type="checkbox"/> Emergency Source has become Not Available
<input checked="" type="checkbox"/> Load Connected to Normal Source
<input checked="" type="checkbox"/> Load Disconnected from Source
<input checked="" type="checkbox"/> Load Connected to Emergency Source
<input checked="" type="checkbox"/> Load Disconnected from Emergency Source
<input checked="" type="checkbox"/> ATS in Auto Mode
<input checked="" type="checkbox"/> ATS Not in Auto Mode
<input checked="" type="checkbox"/> ATS Switch (Rack) in Connected Position
<input checked="" type="checkbox"/> ATS Switch (Rack) out of Connected Position
<input checked="" type="checkbox"/> ATS Switch (Rack) in Test Position
<input checked="" type="checkbox"/> ATS Switch (Rack) out of Test Position
<input checked="" type="checkbox"/> ATS Switch (Rack) in Isolation Position
<input checked="" type="checkbox"/> ATS Switch (Rack) out of Isolation Position
<input checked="" type="checkbox"/> Manual Engine Start Signal is ON
<input checked="" type="checkbox"/> Manual Engine Start Signal turned OFF
<input checked="" type="checkbox"/> Load Energized from Normal Source
<input checked="" type="checkbox"/> Load De-Energized from Normal Source
<input checked="" type="checkbox"/> Load Energized from Emergency Source
<input checked="" type="checkbox"/> Load De-energized from Emergency Source
<input checked="" type="checkbox"/> Alarm Signal is ON
<input checked="" type="checkbox"/> Alarm Signal turned OFF

Figure 35. BIC Alert Configuration Screen

When the QEM is configured for monitoring an E-IO the below screen will be available with the alerts selectable by choosing from a drop down. The Inputs and Output alert functions will be default off but can be configured for alerting when in an ON and/or OFF state

E-IO MODULE 1

Name:

Location:

IP Address:

TCP Port:

Enable Bypass-Isolation Monitoring

E-IO	Enable Alert For	Name
I - 01	None ▼	<input type="text" value="Input 01"/>
I - 02	None On Off	<input type="text" value="Input 02"/>
I - 03	On & Off	<input type="text" value="Input 03"/>
I - 04	None ▼	<input type="text" value="Input 04"/>
I - 05	None ▼	<input type="text" value="Input 05"/>
I - 06	None ▼	<input type="text" value="Input 06"/>
I - 07	None ▼	<input type="text" value="Input 07"/>
I - 08	None ▼	<input type="text" value="Input 08"/>
I - 09	None ▼	<input type="text" value="Input 09"/>
I - 10	None ▼	<input type="text" value="Input 10"/>
I - 11	None ▼	<input type="text" value="Input 11"/>
I - 12	None ▼	<input type="text" value="Input 12"/>
I - 13	None ▼	<input type="text" value="Input 13"/>
I - 14	None ▼	<input type="text" value="Input 14"/>
I - 15	None ▼	<input type="text" value="Input 15"/>
I - 16	None ▼	<input type="text" value="Input 16"/>

Enable Output Control

Figure 36. Device Connection Screen with Ethernet-IO configuration.

## Email (SMTP) Interface

The Simple Mail Transport Protocol (SMTP) facilitates the sending of email alerts to users when alarms occur. The default QEM configuration uses an online ASCO email service that only requires an internet connection to send emails. Network security settings and firewalls will need to allow for the QEM to connect with the internet-based service. Optionally the QEM may be configured to provide mail through a local network email server using the server's IP address, email address and password if authentication is required. Usually the IS department that handles the network servers needs to be contacted to connect to the local mail server.

Figure 37. SMTP Configuration screen

### QEM Recipient Support

The QEM can send emails to up to 5 email addresses. All the emails sent include the same text and alert data: name, location, alarm type, and time. Emails are sent based upon alert that is selected from a configurable predefined list. Enabling SMTP will automatically enable *reset alerts*, sending an email each time the QEM is reset (in addition to the configured alerts).

### Email Configuration and Interface

To enable the email functionality in the QEM, go to the Ethernet Module Configuration Screen in Edit Mode and select the SMTP tab.

It is enabled when a valid email address is typed into one of the email address textboxes, a valid outgoing mail server IP Address is entered, a valid *From Email Address* is entered, and at least one alert is enabled for the transfer switch controller, BIC or E-IO (see Figure 37).

For email servers requiring password support  Enable the *Authentication* and enter a valid *User Name* and *Password*. The default factory settings of the QEM include the email address of a third-party email server (Host Name/IP), a known

DNS server IP Address, a registered third-party email server user name, and password. The user can specify your own destination email address and use the rest of the defaults to test email functionality quickly. For the email to work, the QEM must be connected/configured to a host device (router, gateway server) actively connected to the Internet. You need to enable SMTP mode and assign the IP address of the host device as the gateway IP address of the QEM under the *Quad Ethernet Module* tab.

#### NOTICE

The use of this third-party email server allows the communication statistics to be viewed by ASCO Power Technologies. The data is streamed outside of the local intranet. It could also result in loss of communication if the email server stops functioning or is disabled.

Therefore, for optimal security, once a test indicates the emails are being properly received, it is recommended the QEM route email via the local network.

## SNMP Interface

The Simple Network Management Protocol (SNMP) was created to monitor and manage network devices and hosts. Because of its simplicity it has also been used to monitor other devices (like the QEM). SNMP is disabled by default.

A Management Information Base (MIB) file allows a SNMP client the ability to understand the structure and availability of the managed data in a network device (in this case, the QEM). The MIB file is available through ASCO Customer Care and the ASCO Power Technologies public website.

### QEM Support

The QEM acts as a SNMP agent, providing data to a SNMP Manager on demand. The QEM supports the GET, GETNEXT, GETBULK, TRAP, and RESPONSE commands (SNMP v1 and v2). The QEM does not support the SET or INFORM commands and it does not support SNMP v3.

### SNMP Configuration and Interface

To enable SNMP functionality in the QEM, go to the Ethernet Module Configuration Screen in Edit Mode and select the SNMP tab. Figure 38 shows all the parameters that need to be filled-out to fully enable SNMP in QEM.

The image shows a configuration window titled "SNMP CONFIGURATION". It contains the following fields and controls:

- SNMP Mode:** Two radio buttons, "Enable" (unselected) and "Disable" (selected).
- Get Port Number:** A text input field containing the value "161".
- Trap Port Number:** A text input field containing the value "162".
- SNMP IP Address 1:** A text input field containing the value "0.0.0.0".
- SNMP IP Address 2:** A text input field containing the value "0.0.0.0".
- SNMP IP Address 3:** A text input field containing the value "0.0.0.0".
- Get Community Name:** An empty text input field.
- Trap Community Name:** An empty text input field.
- At the bottom, there are two buttons: "Save" and "Cancel".

Figure 38. SNMP Configuration screen.

### NOTICE

You can configure a maximum of three (3) SNMP managers. All the managers must have the same settings for GET & TRAP ports; as well as with their GET & TRAP community names.

Configuring the SNMP master to view traps is master systems dependent and needs the following information:

- The IP address of the QEM
- The MIB file: ASCO-QEM-987302-xxx.mib (on website)

With regards to SNMP traps, the QEM sends traps from the list of alerts that it monitors which are listed in the **Email Alert Notification and SNMP Traps** configuration window. Note that these alerts are also used to initiate email alerts if SMTP is enabled.

The QEM and the SNMP master(s) should be on the same network.

Details of configuring the SNMP master to view traps are master dependent.

## Remote Transfer Operation

The QEM transfer functionality will be disabled as a factory defaulted and can be enabled by a user with administrator privileges. The transfer options are independent of one another and must be individually enabled. To configure the functionality in the QEM, go to the Ethernet Module Configuration Screen in Edit Mode, select the Transfer Handling tab and the Remote Transfer/Retransfer Operator pop up box appears on the screen (Figure 39).

The capabilities are as follows:

- **Webpage:** Checking this box will allow remote transfer, retransfer and timer bypass operation through the embedded webpage for an Administrator and Control level user.
- **ASCO TCP Master:** Checking this box will allow an ASCO Monitoring and Control System such as the 5700 & 5900 CPMS, 5300 Annunciators and PCS Systems, to initiate transfer/retransfer operations or perform remote configuration of controllers and/or 5200 SERIES Metering using ASCOBus protocol.
- **Alternative ASCO Master Support:** Checking this box will allow ASCO Monitoring and Control System configured for non-ASCOBus protocol to enable transfer/retransfer capability for 5700 & 5900 CPMS, 5300 Annunciators and PCS Systems.

Figure 39. Remote Transfer Operator Screen

### NOTICE

The Group G & Group H controllers will need to have transfer functionality enabled over communication. Reference *Serial Feature 17 in Group G Controller User's Guide 381333-400 & Group H Controller User's Guide 381333-444*.

## Transfer/Re-transfer Operation

When the TS is being controlled remotely, the transfer command may be removed or retained in the event of a loss of communication occurs to all the embedded webpage (including a log out or browser closing), ASCO Monitoring System and third party monitoring being disconnected. To configure the functionality in the QEM, go to the Ethernet Module Configuration Screen in Edit Mode, select the Transfer Handling tab and the Transfer/Retransfer Operator pop up box appears on the screen (Figure 40).

- **Remove Transfer Signal After Time Delay:** This will remove the transfer signal to the controller initiated by a remote monitoring system over Ethernet (embedded webpage or ASCO Monitoring Solution). This the default configuration
  - Time Delay: Configurable time delay for the removal of the transfer signal based upon the loss of communications to all Ethernet monitoring systems. The default configuration is 1 minute/
- **Do Not Remove Transfer Signal:** This will maintain the transfer signal from the QEM to the controller when the connection to all the webpages and monitoring system are lost. Note this will not prohibit the automatic function of the transfer switch controller and should the alternative/emergency source become unacceptable, the switch returns to an acceptable primary/normal source.

Figure 40. Remote Transfer Operation Screen

## Data Encryption

The **AES Mode** encryption port and the ability to enable AES Encryption is used in conjunction with an ASCO Power Technologies monitoring solution, BMS, or SCADA system to add additional security. Both the QEM and the Ethernet master must use the same 128 bit encryption key and communicate using the same port. Usually, particularly on LANs, this feature is not used. On some international non-encrypted versions these settings will not be available. The key is generated by an external monitoring system and loaded into the QEM. This function is disabled by default and to enable, go to the Ethernet Module Configuration Screen in Edit Mode and select the IPv4 tab (Figure 41) and enable for the required TCP port. To configure the AES Key, go to the Ethernet Module Configuration Screen in Edit Mode and select the Advanced tab (Figure 42).

Figure 41. Ethernet TCP/IPv4 Screen

Figure 42. Advance Factory Settings Screen

## Updating Firmware

The users may update the the firmware of the QEM. The firmware is available on the ASCO Power Technologies public website or through Customer Care at 800.800.ASCO. All 5170 modules and many of the 5140 modules use a signed .ASCO file to update the firmware. The 5140 may require a firmware file using an unsigned .bin extension, once the firmware has been updated with a version 22 or later then all subsequent updates will need the signed .ASCO file. If a 5140 has a bootloader version 987213-xxx, then it will require an update using the .bin extension. To upgrade the firmware, go to the Ethernet Module Configuration Screen in Edit Mode, select the Advanced tab and click the Upgrade Firmware button. Popups need to be enabled in the browser.

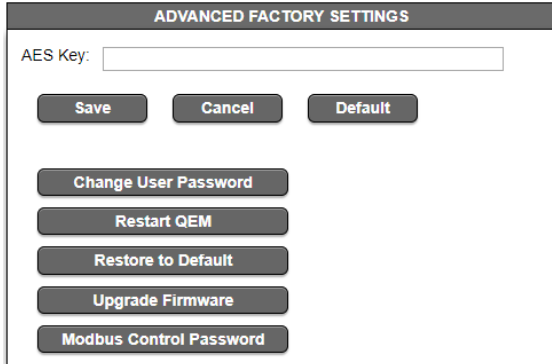

Save the firmware file onto your computer and click the Upgrade Firmware button to begin.

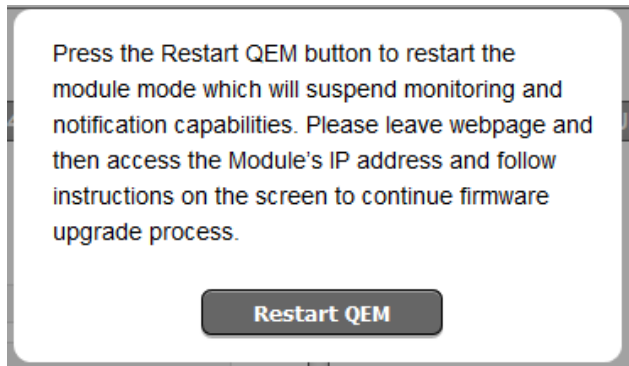

The standard QEM restart icon You will then be prompted to restart the QEM in Upgrade Mode which will disable monitoring and control capabilities.

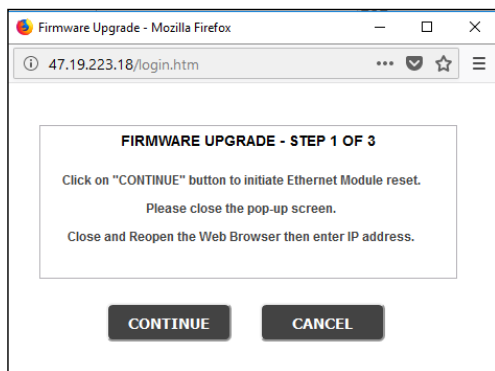

5140 QEM with the unsigned bootloader  
Re-enter the IP address of the QEM into the browser gives you the following screen. You will have the option to browse for the firmware update file or upgrade the firmware or exit Upgrade Mode

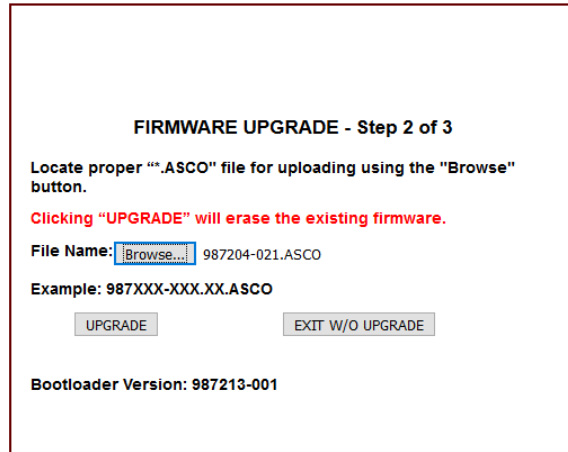

QEM with a signed bootloader

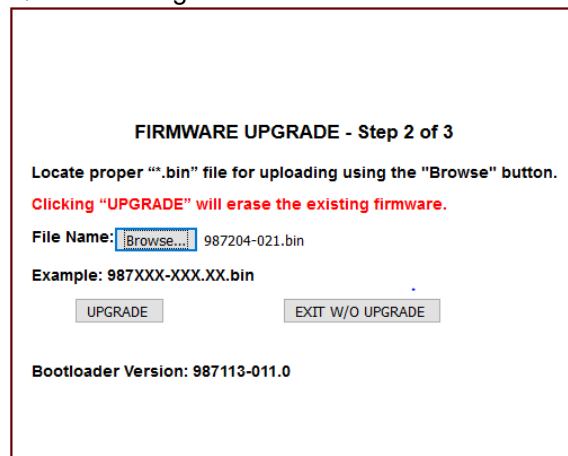

5140 QEM with an unsigned bootloader that requires a .BIN file

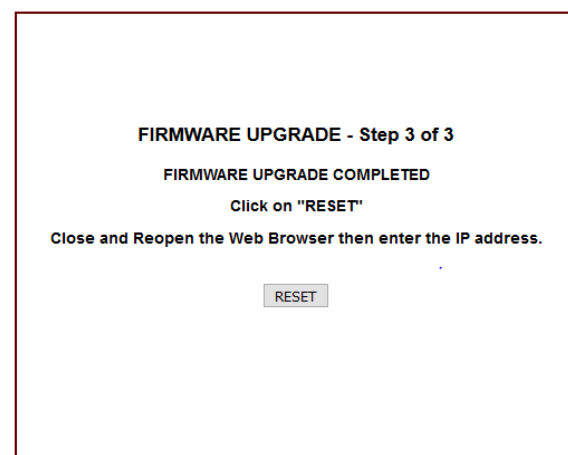

Once the update has taken effect you will get the below screen asking you to reset the QEM into the standard monitoring mode

## Resetting Configurations

### Restore to Default (Reset from Embedded Webpage)

To restore all settings except for the network and password settings, go to the Ethernet Module Configuration Screen in Edit Mode, select the Advanced tab and click “Restore to Default” button (Figure 43). The user will get a popup prompt to initiate the reset.

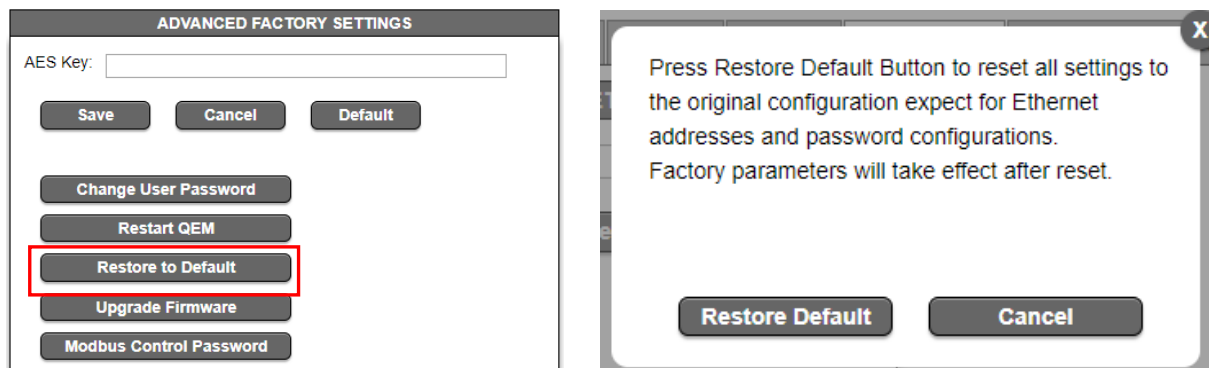

Figure 43. Restore Default Screens

### Reset Button

A reset button (hole in the top) is provided to restore network settings and passwords to the factory default settings. The button should be held for a minimum of 30 seconds.

### Restart (Power Cycle)

To cycle the power without directly interfacing or adjusting the hardware, go to the Ethernet Module Configuration Screen in Edit Mode, select the Advanced tab and click “Restart QEM” button (Figure 44). The user will get a popup prompt to initiate the power cycle.

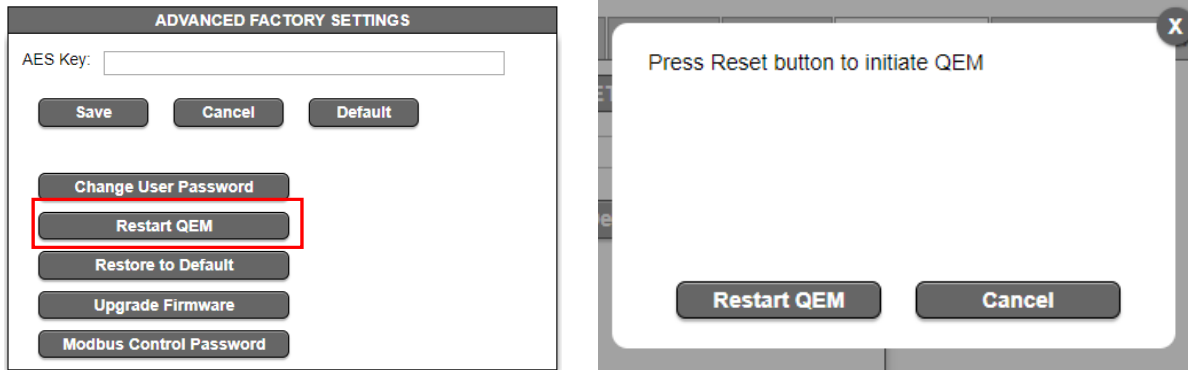

Figure 44. Restart QEM

# Troubleshooting



To avoid possible shock, burns, or death, de-energize all electrical sources to the transfer switch before working on the QEM.

## Status Lights (LEDs)

### Power Light

This light should be on under normal operating conditions

LED Name	Color	Status	Description
Power	Green	off	QEM is not energized, it is turned off
		on	QEM is energized, it is turned on and working

### Ethernet Connection Lights

These lights should be blinking under normal operating conditions

LED Name	Color	Status	Description
Activity	Green	off	There is no activity on the link
		on	Flashing indicates activity on the link
Link Speed	Yellow	off	There is no link connection
		on	There is a link connection
TX Transmit	Green	off	Not transmitting
		on	transmitting
RX Receive	Red	off	Not receiving
		on	receiving

### Diagnostic Light

This light should be off under normal operating conditions

LED Name	Color	Status	Description
Diagnostic	Red	Solid on	QEM in boot loader (starting up)
		off	QEM in normal operating condition
		1 blink	RAM checksum error
		2 blinks	FRAM error
		3 blinks	SRAM error
		4 blinks	Duplicate IP address on the network

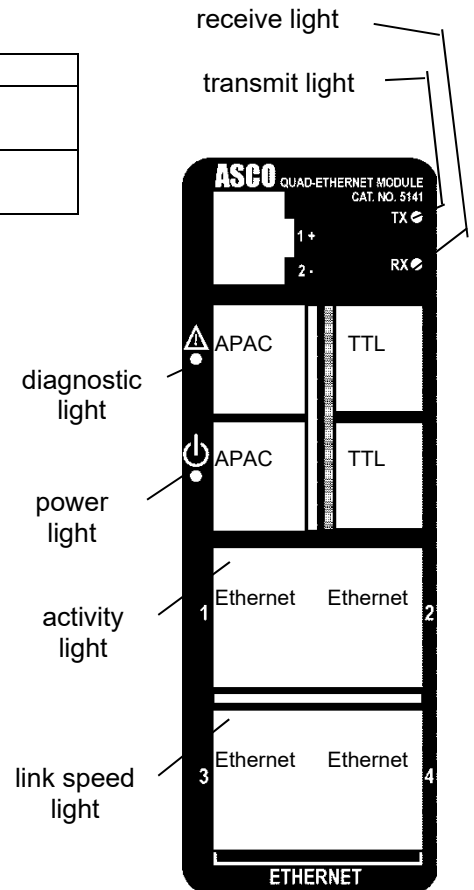

## Web Pages are not accessible

If the QEM web page is not accessible, try the following procedure:

1. Open the command prompt on the computer. Type *cmd*
2. To check network connectivity status, type *Ping xxx.xxx.xxx.xxx* in command prompt.
3. The default prompt of the QEM is 169.254.1.1 (see page 7).
4. To check continuous network connectivity status, type *Ping xxx.xxx.xxx.xxx -t* in command

## Dashboard Screen

The Dashboard Screen (Figure 45) will automatically adjust based upon the connected and configured equipment. The overall layout of the dashboard will adjust based on the configured equipment. If there is a controller connected, it will be at the top of the screen followed by configured BIC, E-IO and all metering tiles below

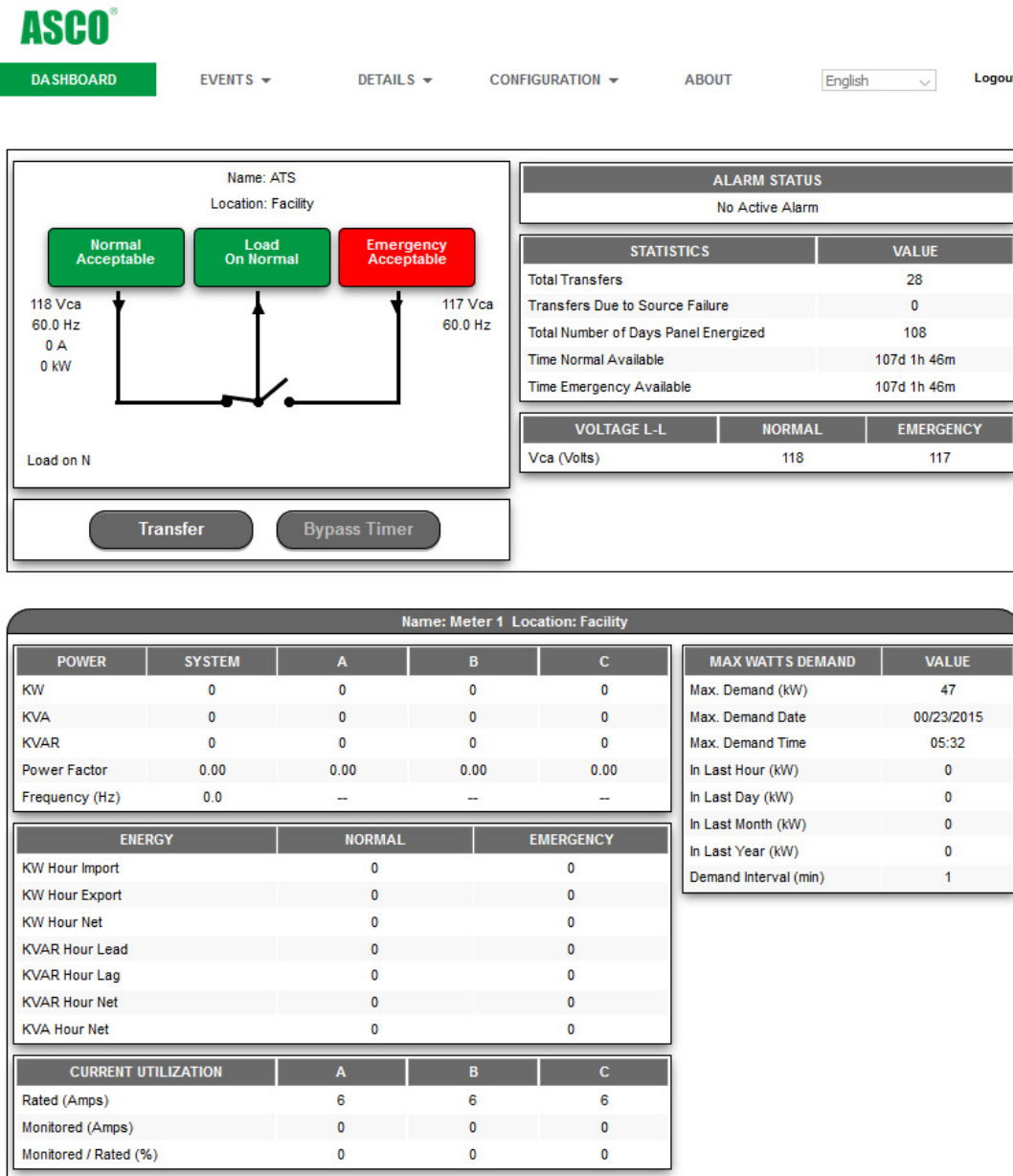

Figure 45. Dashboard Screen Group 5 Controller with a single Power Meter

Controller information adjusts to the configured ASCO transfer switch controller, Group 5, Group H or Group G controller. When the QEM is connected to an ASCO transfer switch the controller tiles provide a oneline diagram, active alerts and transfer switch statistics.

The oneline will show source availability, switch position and which source is feeding the load through graphical indication. Controller configured name and location will be shown above the oneline while the status of the transfer switch will be shown. The respective voltage and frequency of each source will be shown on the respective side of the oneline and when a transfer switch is equipped with a load mounted 5200 SERIES Meter, the current and KW will be shown for the source the transfer switch contactor is closed on.

Transfer switch statistics are retrieved from the controller and will be displayed; the Group 5, Group H and Group G controllers have different transfer switch statistics (Figure 46).

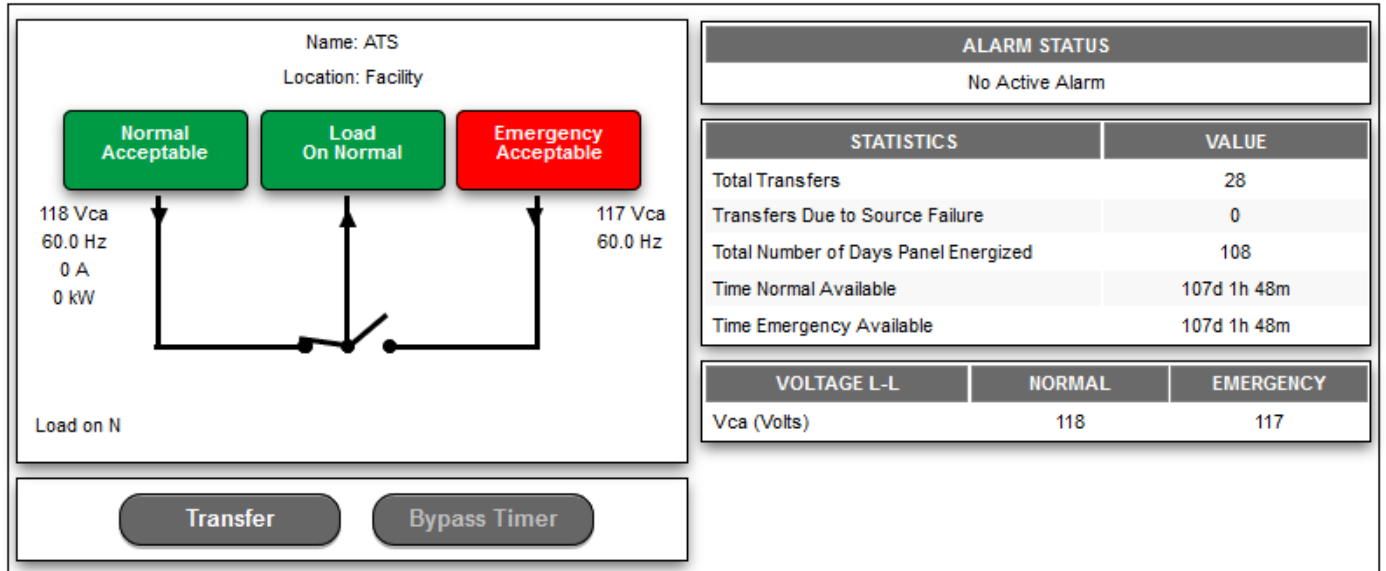

Figure 46. 7000 SERIES with Group 5 Controller

Alarm status from the controller will be displayed. An icon will flash on the upper right corner of the screen and the name of active alarms appears in the Alarm Status tile.

When a SERIES 300 Transfer Switch with the Group G is equipped with an Acc. 23 the current utilization tile appears below the controller tile and will populate with the real time current, current rating and the utilization percentage. This tile will be part of the Metering tiles if a switch is equipped with 5200 SERIES Metering.

When a 4000 SERIES Transfer Switch with the Group H is equipped with a BIC the oneline will change to that of a main transfer switch with a bypass-isolation transfer switch. Also, a new alert tile and status tile for the BIC shall populate the dashboard.

If a 5112 Ethernet-IO is configured to be monitored on an ASCO transfer switch the E-IO tiles appears below the transfer switch controller and BIC tiles. The status and name of the IO points will populate the E-IO tiles with each of the monitored E-IO Modules getting its own tile. Should control for the 14 Input / 2 Output Module be enabled, output control buttons will also populate the screen.

When a 7000 SERIES Transfer Switch with the Group 5 is equipped with an E-IO for bypass-isolation monitoring the oneline will change to that of a main transfer switch with a bypass-isolation transfer switch.

If a 5112 Ethernet-IO is configured to be monitored on an ASCO transfer switch the E-IO tiles appears below the transfer switch controller and BIC tiles. The status and name of the IO points will populate the E-IO tiles with each of the monitored E-IO Modules getting its own tile. Should control for the 14 Input / 2 Output Module be enabled, output control buttons will also populate the screen.

If 5200 SERIES Metering is configured to be monitored on an ASCO transfer switch the Metering tiles appears below the controller, BIC and/or E-IO tiles. The metering tile contains real, reactive and apparent power and power factor for each phase and the system. The system frequency will be monitored. Real energy (Imported, Exported & Net), Reactive Energy (Lead, Lag & Net) and Apparent Energy (Net) will display. Maximum Watt demand is captured showing the date and time stamp and the demand interval that the measurement is read. If the 5200 SERIES Metering is the Model 5210 Digital Power Meter, the maximum watt demand from the past hour, day, month and year will display.

## Events Screen

The Events screen displays events stored in the ASCO transfer switch controller, BIC and E-IO. Events will be displayed in chronological order with the event type, date & time stamp and a cause of the event, if captured. The maximum number of events match the maximum for the device from which it is being retrieved.

## Details Screen for Controllers & BIC

The details page displays the oneline with its status and analog parameters as well the alarm tile for all active alerts from the Dashboard Screen. The QEM's provide a read only view of the settings. The Details Screen displays a read only equipment setup, configuration data depending on the controller.

## Details Screen for 5200 SERIES Metering

The details page displays the Oneline with its status and various analog parameters from the Dashboard Screen. The QEM's can provide a read only view of the metering configuration and several electrical system parameters including values for current, line-to-line voltage, line-to-neutral voltage and total harmonic distortion (for 5210 DPM). Normal and emergency real energy consumption and maximum watt demand information will be displayed along with the average minimum and maximum of normal and emergency values.

## About Screen

The about screen of the QEM displays basic configuration information for the module, controller and 5200 SERIES metering along with firmware and bootloader version. Contact information for ASCO Power Technologies will also be displayed on this page. Information on this screen is important for ASCO support and will be required for troubleshooting.

## RS485 ASCOBus and Modbus (5170 Only)

The RS485 port may be used for outbound direct communication to an ASCO Monitoring System or to Modbus Master. Enabling this functionality disables TCP/IP monitoring capabilities including webpage, email, SNMP, Modbus TCP/IP and ASCOBus over TCP/IP.

1. Remove rear cover of the 5170. Locate J207 on the 987112 board assembly. The jumper is installed onto Pins 2 and 3 as the default setting as shown in Figure 47.

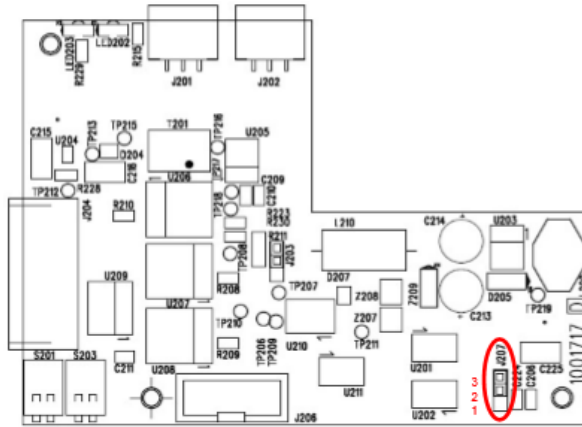

Figure 47. Current location of jumper pins

2. Move the jumper to the Pin 1 & 2 location of J207 as shown in Figure 48. Then place the cover back onto the module.

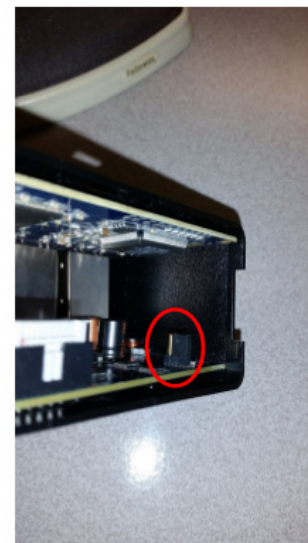
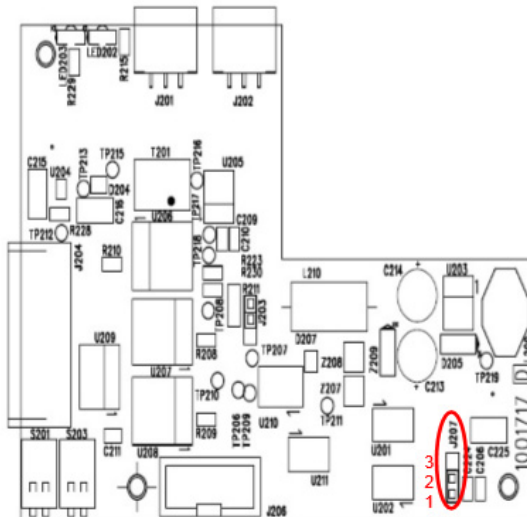

Figure 48. New location of jumper pins

## Communication Address Form for 5140/5170 Quad-Ethernet Module (QEM)

Row No.	IP Address	Subnet mask	Gateway	ATS Serial No.	ATS Catalog No.	Address set in ATS Controller*	Address set in DPM
1							
2							
3							
4							
5							
6							
7							
8							
9							
10							
11							
12							
13							
14							
15							
16							

### Instructions

Fill in the information for each 5140 Quad-Ethernet Module (Acc. 72EE) provided with a New Series 300 Transfer Switch and/or 5210 Digital Power Manager or 5170 Quad-Ethernet Module (Acc. 72EE2) provided with a 4000 or 7000 Series ATS and/or 5210 Digital Power Manager.

## Connecting 5170 QEM to Ethernet for Group 5, 5210 Digital Power Meters (DPM), and 5220 Power Manager Xp (PMXp) monitoring using TTL and/or RS485

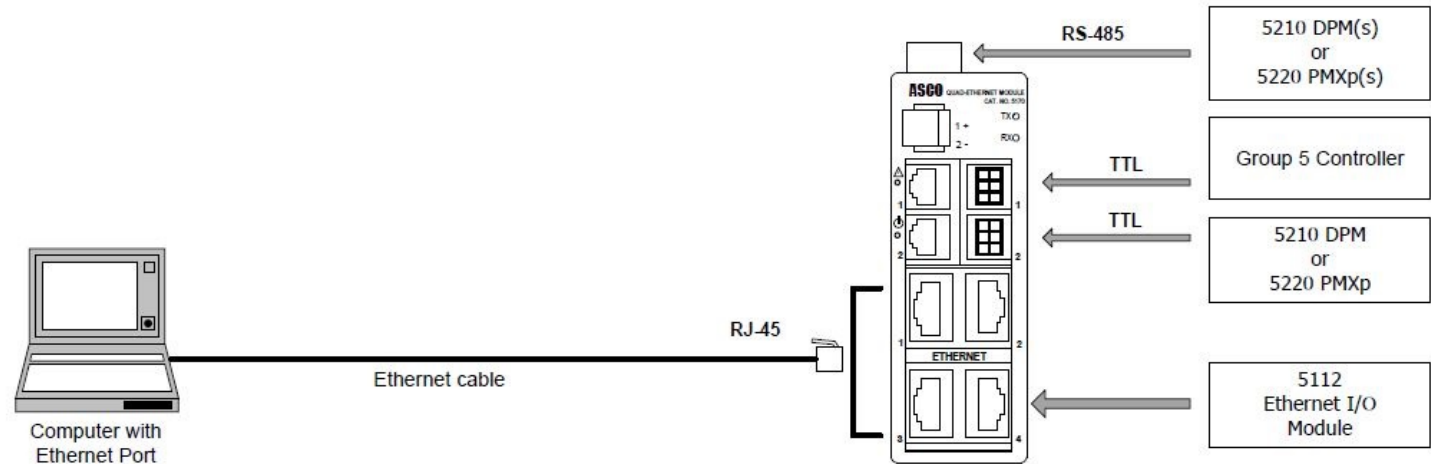

IP Address: 169.254.1.100 (suggested for initial configuration)  
 Subnet: 255.255.0.0  
 Gateway: 0.0.0.0

**Factory Default Settings**  
 IP Address: 169.254.1.1  
 Subnet: 255.255.0.0  
 Gateway: 0.0.0.0

Required Configuration over Ethernet			
ASCO Devices	TCP/IP Protocol	Default Monitoring Address	ASCOBusII (Configure to use TTL/RS485)
Group 5 Controller	MODBUS	1	1
	ASCOBUS	1	1
	SNMP	Use MIB <sup>2</sup>	Enable SNMP (See User Guide Manual) <sup>3</sup>
Digital Power Meter (DPM) or Power Manager	MODBUS	2	Configurable (See Note 1)
	ASCOBUS	1	(See Note 1)
	SNMP	Use MIB <sup>2</sup>	Enable SNMP (See User Guide Manual) <sup>3</sup>
Additional DPM's or Power Managers	MODBUS	3,4,5	3,4,5
	ASCOBUS	2,3,4	2,3,4,5
	SNMP	Use MIB <sup>2</sup>	Use MIB <sup>2</sup>
Ethernet I/O Module	MODBUS	8,9	N/A <sup>5</sup>
	ASCOBUS	8,9	N/A <sup>5</sup>
	SNMP	Use MIB <sup>2</sup>	N/A <sup>5</sup>

**Footnotes:**

- 1) Use of the Digital Power Meter / Power Manager requires enabling on the 5170 QEM Configuration webpage.
- 2) MIB = Latest ASCO-QEM-987302-XXX.mib
- 3) User Guide Manual = 381333-459x, where 'x' is latest revision
- 4) Note: All monitored devices must be on one connection type, either: TTL/RS485 or APAC.
- 5) Ethernet I/O Module uses Ethernet (Does not support ASCOBUSII).

# Connecting 5170 QEM to Ethernet for Group 5, 5210 Digital Power Meters (DPM) and/or 5220 Power Manager Xp (PMXp) monitoring using TTL and/or RS485

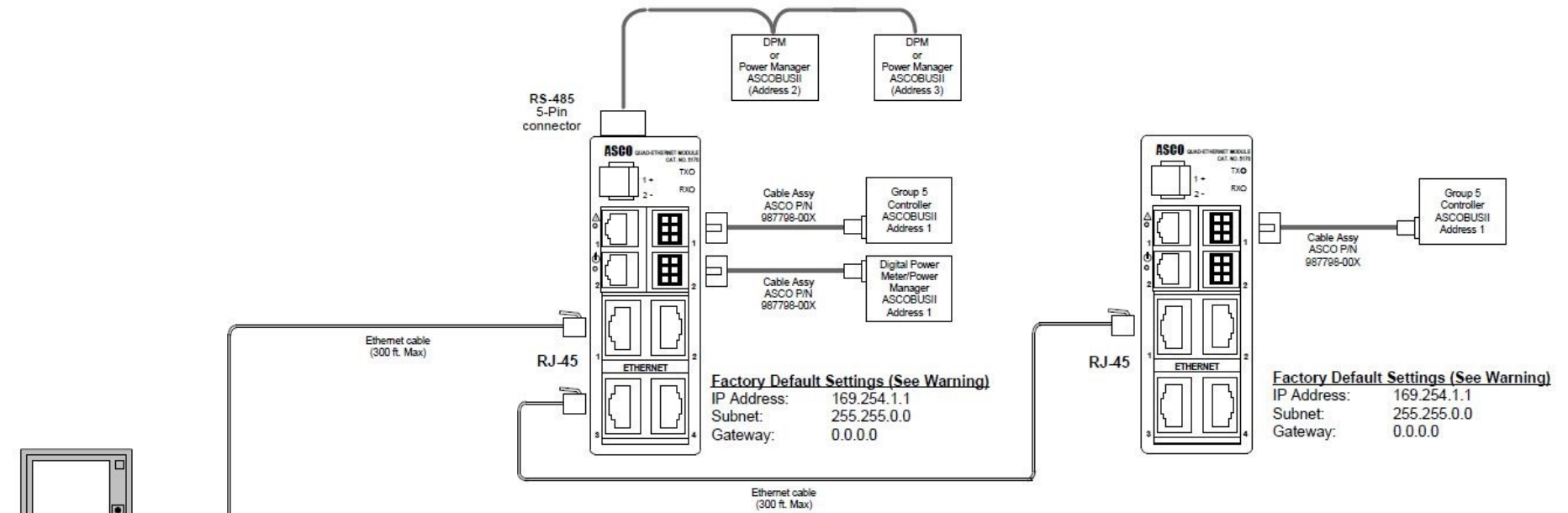

Computer with Ethernet Port

IP Address: 169.254.1.100 (suggested for initial configuration)  
 Subnet: 255.255.0.0  
 Gateway: 0.0.0.0

**WARNING:** DO NOT CONNECT MULTIPLE 5170 Units together with the same IP Address.  
 (Default is 169.254.1.1 – Change Before Ethernet Daisy Chaining)

**For RS-485 4-Wire Connections**

72EE2	DPM	PWR MGR
(1) Rx+	(3) Tx+	(1) Tx+
(2) Rx-	(4) Tx-	(2) Tx-
(3) Tx+	(1) Rx+	(3) Rx+
(4) Tx-	(2) Rx-	(4) Rx-
(5) COM	(5) COM	

Note: Switches on 72EE2, DPM & PWR MANAGER must be set to '4-Wire' (Default)

# Connecting 5170 QEM to RS485 for Group 5, 5210 Digital Power Meters (DPM) and/or 5220 Power Manager Xp (PMXp) monitoring using TTL

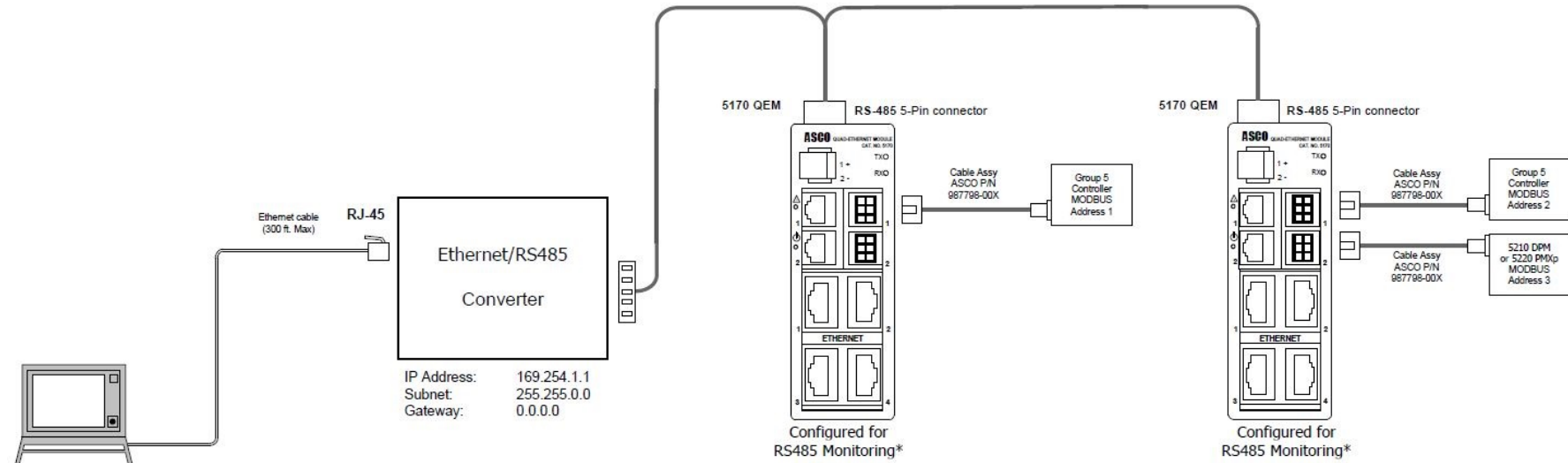

IP Address: 169.254.1.100 (suggested for initial configuration)  
 Subnet: 255.255.0.0  
 Gateway: 0.0.0.0

RS-485 2-Wire Connections

72EA2
(3) Tx+
(4) Tx-
NC
NC
(5) COM

Note: Switches on the 5170 QEM must be set to '2-Wire'.

RS-485 4-Wire Connections

72EA2
(3) Tx+
(4) Tx-
(1) Rx+
(2) Rx-
(5) COM

Note: Switches on the 5170 QEM must be set to '4-Wire' (Default setting).

**Suggested Device Addresses**

ASCO Devices	TCP/IP Protocol	Default Monitoring Address
Group 5 Controller	MODBUS	1, 3, 5, 7, ...
	ASCOBUS	1, 2, 3, 4
Digital Power Meter (DPM) or Power Manager	MODBUS	2, 4, 6, 8, ...
	ASCOBUS	1, 2, 3, 4

(\*) To configure a 5170 QEM for RS485 communication to a monitoring system reference RS485 section of QEM manual.

### Connecting 5140 QEM to Ethernet for Group G/H & 5210 Digital Power Meters (DPM)

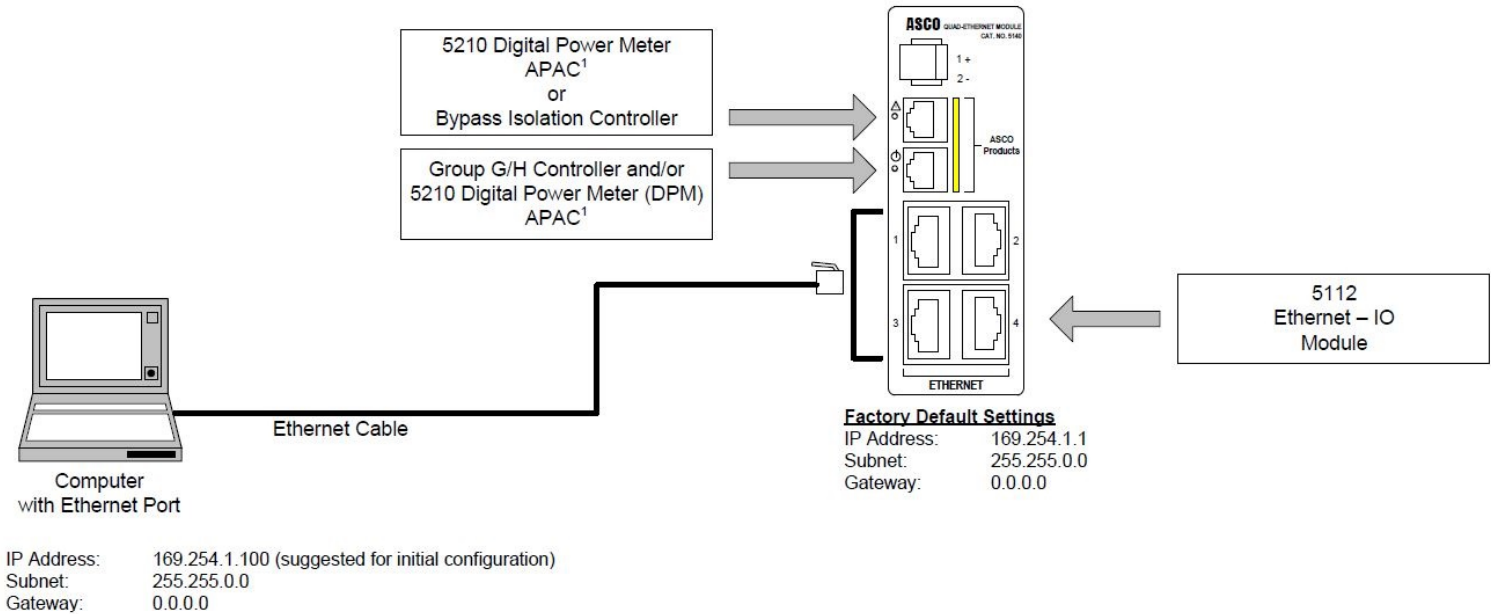

Required Configuration over Ethernet			
ASCO Devices	TCP/IP Protocol	Default Monitoring Address	5140 QEM APAC SETTINGS
Group G/H Controller	MODBUS	1	16
	ASCOBUS	1	16
	SNMP	Use MIB <sup>2</sup>	Enable SNMP (See User Guide Manual) <sup>3</sup>
Digital Power Meter (DPM)	MODBUS	2	20 - 23
	ASCOBUS	1	20, 21, 22, 23
	SNMP	Use MIB <sup>2</sup>	Enable SNMP (See User Guide Manual) <sup>3</sup>
Bypass Isolation Controller	MODBUS	4	4
	SNMP	Use MIB <sup>2</sup>	Enable SNMP (See User Guide Manual) <sup>3</sup>
Ethernet I/O Module	MODBUS	8, 9	N/A <sup>4</sup>
	SNMP	Use MIB <sup>2</sup>	Enable SNMP (See User Guide Manual) <sup>3</sup>

Footnotes:

- 1) APAC = ASCO Power and Communications Bus
- 2) MIB = Latest ASCO-QEM-987302-XXX.mib
- 3) User Guide Manual = 381333-459
- 4) Ethernet I/O Module uses Ethernet (Does not support APAC).

### Connecting 5140 QEM to Ethernet for Group G/H & 5210 Digital Power Meters (DPM)

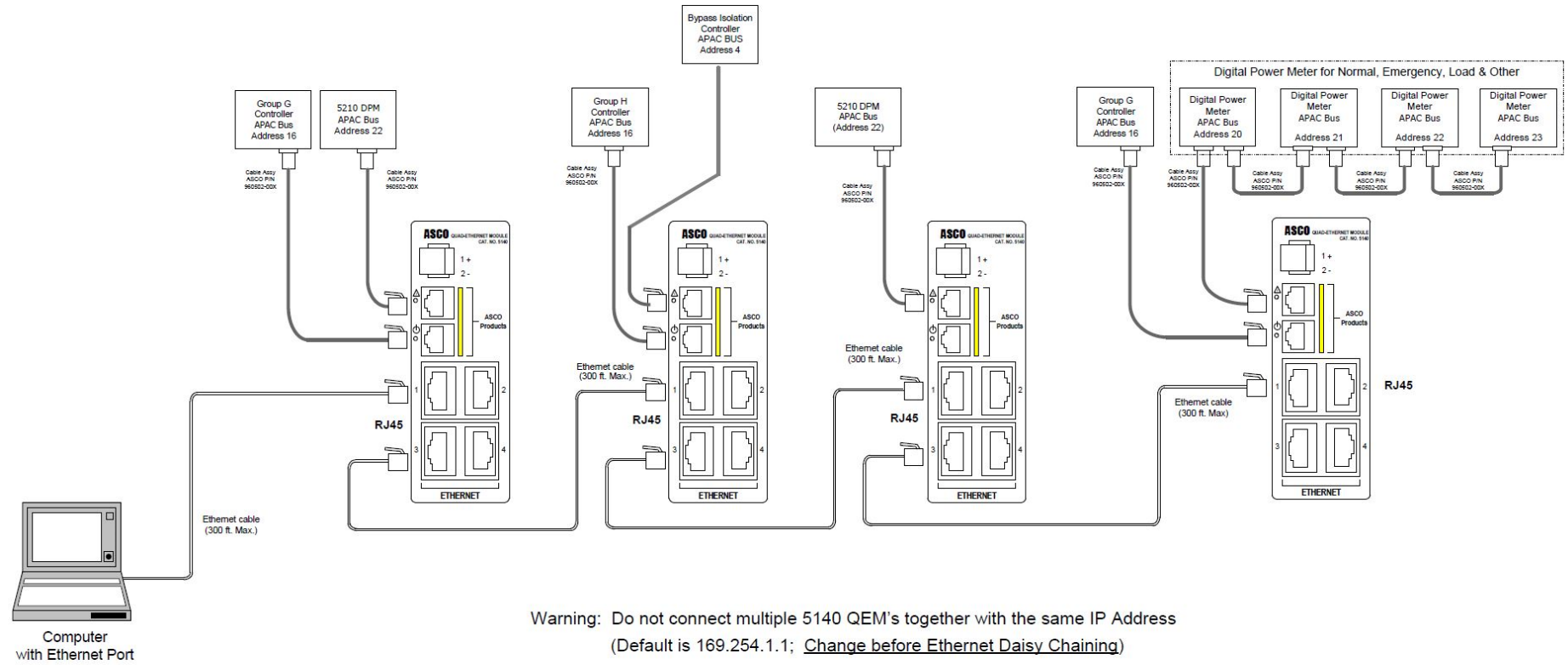

IP Address: 169.254.1.100 (suggested for initial configuration)  
 Subnet: 255.255.0.0  
 Gateway: 0.0.0.0

# INDEX

## A

About, 44  
 Acc. 72EE, 4  
 Acc. 72EE2, 4  
 Access Levels, 18  
 Admin, access level, 18  
 Address form(s), 46  
 Addresses, 23, 28, 35  
 Alerts, 32, 33,34, 35, 36, 42 ,44  
 APAC, 4-6, 10, 11, 19, 21, 25, 41  
 ASCObusII TCP configuration, 29

## C

Change Password, 14  
 Configuration, Computer, 12  
 Configuration, Resetting, 29  
 Configuration, Screens, 18  
 Connections, 10,11,12  
 Control, access level, 13  
**Controller, Group 5**, 4, 10, 19, 20, 42, 43  
     User's Guide, 381333-126  
 Controller, Group G, 4, 19, 21, 37, 42  
     User's Guide, 381333-400

## D

Dashboard, 14-16, 41, 43, 44  
 Details, 45  
 Devices, 5, 10, 29, 30, 36  
 Diagnostic light, 41  
 Dimensions, 5  
 DPM 5210, 10, 11, 25, 47-51  
     Operator's Manual 381333-368

## E

Edit mode, configuration, 29-35  
 Email alerts, 35, 26  
 Events, 44

## F

Form, communication address, 46

## G

Glossary, 4  
 Group 5 Controller, 4, 10, 19, 20, 42, 43  
     User's Guide, 381333-126

## H

Help, Troubleshooting, 41  
 1-800-800-2726 in the US  
 customercare@ascopower.com

## I

Installation, 5  
 IP address, 29

## L

LEDs, status, 42  
 Login, 10, 13, 18

## M

MAC address, 4, 28  
 Manuals,  
     DPM 5210, 381333-368  
     PM Xp 5220,381333-199  
 Modbus TCP interface, 5, 28, 29  
 Modbus Test Suite interface  
     example, see 381339-319  
 Monitor, access level, 18  
 Mounting, 10

## N

Network, 4 ,11, 12

## O

Outline drawing, 47, 48,49, 50, 51

## P

Password, 13, 14, 18, 19  
 Ports, 5, 10, 11  
 Power light, 41  
 Power Manager Xp,  
     Operator's Manual 381333-199  
 Power Meter, Digital, 2, 5, 31  
     Operator's Manual 381333-368  
 Power requirements, 5

## S

SMTP interface, 35  
 SNMP interface, 36  
 SNMP Master configuration  
     iReasoning Master,  
     see 381339-320  
 Specifications, 5  
 Status lights, 41

## T

Transfer Switch, 4000, 7000  
 SERIES  
     Group 5 Controller, 43  
     User's Guide, 381333-126  
     Web pages, 5, 15, 41  
 Troubleshooting, 41  
 TTL, 4, 5, 11, 19, 41

## U

User name (access level), 15, 35  
 User requirements, 15

## V

Voltage, 5, 30 43, 44  
     Group 5 Controller  
     User's Guide, 381333-199

## W

Web page interface, 15  
 Web page design & navigation, 16