

# ATS Remote Annunciator Catalog 5310 Installation Manual

**381333-317 B**  
**3/2017**

The ASCO 5310 ATS Remote Annunciator is listed under the Underwriter’s Laboratories Standard UL-1008 for Automatic Transfer Switch accessories. This stand-alone device provides individual status monitoring and control of an ASCO Automatic Transfer Switch (ATS) over an ethernet network. The ATS must have an ASCO 5150 Connectivity Module (CM) (Acc. 72E) connected to it. The Catalog 5310 can communicate with these ATSs:

- 7000 & 4000 Series (Group 5 Controller)
- Series 300 (Group 1 Controller)
- Series 185 (Group 4 Controller)

The ASCO 5310 complies with US UL requirements. It also has IEC Certification (CE Mark).

**Product Functions and General Descriptions:**

Separate lights indicate switch status and position.

- ATS switch position
- ATS source availability
- ATS alarm condition
- ATS time delay active

Separate push buttons initiate transfer switch operation / testing, alarm silence, and reset.

- ATS transfer test (*Transfer*) / bypass (cancel) time delay
- Silence alarm
- Reset



Front view

The ATS Remote Annunciator can also be setup in multiple locations to monitor the same device. This arrangement allows for redundant annunciation of business-critical ATSs.

**After the ATS Remote Annunciator is installed and configured refer to User’s Guide 381333-316.**



DANGER is used in this manual to warn of a hazard situation which, if not avoided, will result in death or serious injury.



WARNING is used in this manual to warn of a hazardous situation which, if not avoided, could result death or serious injury.

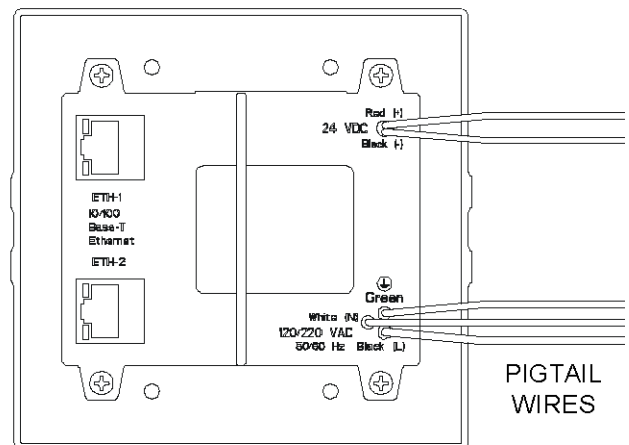

Rear view

# Table of Contents

Specifications..... 3

Installation..... 3

Functional Test ..... 4

ATS Remote Annunciator Configuration ..... 5

ATS Configurations ..... 7

Diagnostics ..... 9

Troubleshooting..... 10

Installation Drawings & Wiring Diagrams ..... 11

Index..... 14

## ▲ WARNING

### POTENTIAL COMPROMISE OF SYSTEM AVAILABILITY, INTEGRITY, AND CONFIDENTIALITY

- Change default passwords to help prevent unauthorized access to device settings and information.
- Disable unused ports/services and default accounts to help minimize pathways for malicious attackers.
- Place networked devices behind multiple layers of cyber defenses (such as firewalls, network segmentation, and network intrusion detection and protection).
- Use cybersecurity best practices (for example, least privilege, separation of duties) to help prevent unauthorized exposure, loss, modification of data and logs, or interruption of services.
- All programming software should be kept in secured locations and should never be installed in or connected to any network other than the network for which the software is intended.
- All methods of mobile data exchange with the isolated network such as CDs, USB drives, etc. should be scanned before use.
- Laptops and smart devices that have connected to any other network besides the intended network should never be allowed to connect to the safety or control networks without proper sanitation.
- Minimize network exposure for all control system devices and/or systems and ensure that they are not accessible from the Internet.
- When remote access is required, use secure methods, such as Virtual Private Networks (VPNs), recognizing that VPNs should be updated to the most current version available. Also recognize that VPN is only as secure as the connected devices.
- Communication protocols are accessible on a network, therefore best practices should be used to transfer sensitive information and to prevent unauthorized access.

**Failure to follow these instructions can result in death, serious injury, equipment damage or loss of sensitive data.**

# Specifications

Power Requirements: 120-220 V ac nominal (90-264 V ac)  
 auxiliary 24 V dc nominal (9-36 V dc) can be a battery or UL rated Class 1 dc power supply  
 max. power 10 watts ac or 5 watts dc  
 Dimensions: 4.47" H x 4.61" W x 3.91" D (11.35 cm H x 11.7 cm W x 9.92 cm D)  
 Weight: 15.3 oz. (0.437 kg)  
 Ethernet Communication Cable Requirements: Belden 1583A or equiv. UTP CAT 5e or CAT 6 with RJ45 connectors (untwisted pair or higher)  
 Ethernet Port Connectors: Two built-in 10/100 Base T (RJ45) 10/100 Mbps  
 Configuration Parameters: (The parameters required to make an Ethernet connection)  
 IP Address 169.254.1.200  
 Subnet Mask 255.255.255.0  
 Gateway  
 TCP Port No. 10001  
 A label on the back shows the default settings.  
 Protocol Support: ASCO II and Modbus/TCP  
 Ambient Temperature:  
 Operating -4 to 158 deg F (-20 to 70 deg C)  
 Storage @ 5-85 % humidity -40 to 185 deg F (-40 to 85 deg C)  
 Number of Channels 1  
 Internal Alarm Buzzer

## 1 Factory Default Information

A label on the back to the ATS Remote Annunciator lists several important settings that you will need to do the configuration. **Write down this information below before installing it (and after changing these settings).**

IP Addr	_____
factory default:	<b>169.254.1.200</b>
Login	_____
factory default:	<b>admin and user</b>
	(see page 4 for Login names)
Password	_____
factory default:	<b>ASCO</b> (capital letters)
Configured IP Address	_____
factory default:	<b>169.254.1.200</b>
	(customer's IP address)

# Installation

The ASCO 5310 ATS Remote Annunciator can be attached to a double gang box (supplied). Refer to the installation drawing 834979 and wiring diagram 850281 at the back of this manual.

## 1 Gang Box Mounting

Refer to installation drawing 834979 sheet 1. After the wiring is completed, four screws (supplied) attach the unit to the gang box. The front bezel snaps onto the unit after it is attached to the gang box.



To avoid shock, burns, or death, deenergize all electrical sources before making connections.

## 2 Power Wiring

A licensed electrician should install the ATS Remote Annunciator. All national and local codes must be followed.

Refer to wiring diagram 850281. The unit has pigtail wires. Wire nuts are provided to connect power wiring inside the gang box. Recommended wiring is #18 AWG stranded flexible wire. If the power wiring is solid wire, pigtail it with stranded flexible wiring to the ATS Remote Annunciator.

The white divider must be installed on the back on the unit.



Be sure to install plastic divider on the back of the unit to separate power wiring from ethernet wiring.

## 3 Communication Wiring (Ethernet)

Refer to wiring diagram 850281. The communication wiring and ac power wiring must be isolated. Use Belden 1583A cable or equivalent UTP CAT 5e or CAT 6 with RJ-45 connectors (untwisted pair or higher). Connect the Ethernet Port to the network.

### 3-1 Communication Architecture

Refer to wiring diagram 850281. Overall communication architectures are shown on the drawings.

# Functional Test

After installing the ATS Remote Annunciator communications must be established to configure it. A *Windows*-based laptop computer is needed. You must have access to the other end of the communication cable that is connected to the ATS Remote Annunciator. You also need to know the factory default settings on the label (see page 2).

## 1 Initial checks

After the ATS Remote Annunciator is mounted and wired (both power and communication) perform these tests:

1. Turn on the power to energize the ASCO 5310.
2. Verify that the power light is illuminated (upper left).
3. Turn the **Control** key switch to the right (unlocked).

## 2 Communication check

A laptop computer running *Windows Xp & 7* and *Internet Explorer 6.0 +* will be used in these steps to configure the ATS Remote Annunciator. You will need to temporarily disconnect the other end of the communication cable from ATS Remote Annunciator and connect it instead to the laptop computer.

1. Connect the Ethernet cable from the ATS Remote Annunciator to the laptop computer's Ethernet jack.
2. Start *Windows*, click the **Start** button, then **Control Panel**.
3. Select **Network Connections** (*Windows Xp*) or **Network and Internet** and/or **Network and Sharing Center** (*Windows 7*).
4. Double click the **Local Area Connections** icon to display the properties screen (*Windows Xp*) or select **Local Area Connections** then click the **Properties** button (*Windows 7*).
5. On the **Local Area Connection Status** screen click the **Properties** button.
6. On the **Local Area Connection Properties** screen:

### *Windows Xp*

Scroll to verify that *Internet Protocol (TCP/IP)* is selected and highlighted, then click the **Properties** button.

### *Window 7*

Scroll to verify that *Internet Protocol Version 6 (TCP/IPv6)* is deselected, *Internet Protocol Version 4 (TCP/IPv4)* is selected and highlighted, then click the **Properties** button.

7. Set the IP setting of the laptop computer (see Figure 1):  
 IP Address      169.254.1.100  
 (last digit must be different than ASCO 5310 Default IP)  
 Subnet Mask 255.255.255.0 (same as ASCO 5310)  
 Default Gateway leave blank  
 (This is needed only if communicating to a different LAN.)
8. Click **OK** and click **Close**. Close the *Local Area Connection* window.
9. Once the TCP/IP setup is complete at the laptop computer, restart the computer (click **Start** button, then click **Restart**).
10. Restart *Windows*, then click the **Start** button.  
*Windows Xp*  
 Select **All Programs > Accessories > Command Prompt**.  
*Windows 7*  
 In *Command Prompt* window type **cmd** and press **ENTER**.
11. In the command prompt window type **ipconfig** and press **ENTER**. The settings are displayed.
12. In the command prompt window type **ping 169.254.1.200** and press **ENTER**.  
 You should see:      *Reply from 169.254.1.200*  
 This reply confirms communication between the laptop computer and the ATS Remote Annunciator. Close the command prompt window. Proceed to the Configuration, *Login* screen.



**Figure 1: Internet protocol**

**NOTE:** If you have multiple ATS Remote Annunciators, each one must be checked and configured separately in this way.

# ATS Remote Annunciator Configuration

The ATS Remote Annunciator must be configured. First log in. The ATS Remote Annunciator sends HTML files to the client computer. *Internet Explorer* interprets these HTML files, formats them, and displays the embedded web pages to the user.

## 1 Login Screen

To login follow these steps:

1. Be sure that the computer is still connected (page 4).
2. Start the *Internet Explorer* browser on the computer.
3. In the address bar, type in the default address of the ATS Remote Annunciator, then press **Enter**:  
http://169.254.1.200
4. The ATS Remote Annunciator login page should appear. Enter the default Login ( admin ) and Password ( ASCO ) from the label (see page 2) and click **Login**. See Figure 3.



Figure 2: Login screen

### 1-1 Login Names

Two predefined login names are provided:

**admin** for administrator (can change configuration and diagnostic functions).

**user** can only see diagnostic screens in the web interface. The user cannot change any configurations.

### 1-2 Change Password

The default password is on the label ( ASCO ).

To change the password, click **Change Password**. The password can be up to 15 characters (do not use spaces). You can set only one password. Type in the *Old Password*, the *New Password*, and *Retype [new] Password*. Then press **OK** to save it. If you make a mistake click **Reset** and start over.



Figure 3: Change password screen

## 2 Annunciator Configuration

5. On the left pane, under *Configurations*, click *Annunciator* to configure the ATS Remote Annunciator. See Figure 4.

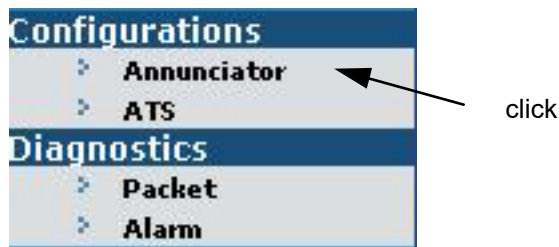

Figure 4: Configurations > Annunciator

6. The Configurations > Annunciator screen appears. See Figure 5. The configurations features are:

Annunciator name, software upgrade, IP address, subnet mask, gateway address, port, encryption, buzzer mode.

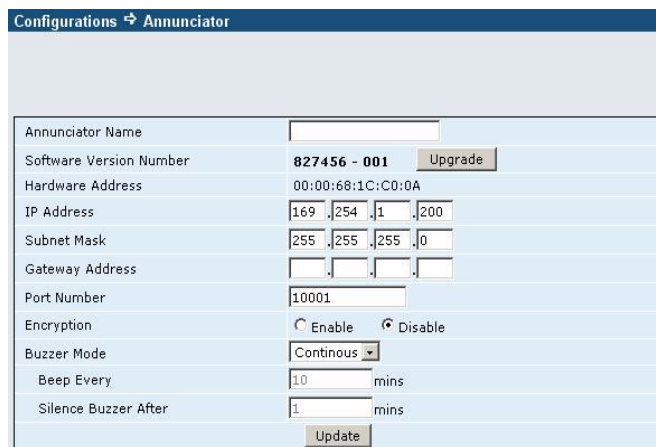

Figure 5: Configurations > Annunciator

### 2-1 Annunciator Name

Enter a name for the ATS Remote Annunciator.

Also write the name here

### 2-2 Software Upgrade

Write the software version here

The firmware in the ATS Remote Annunciator can be upgraded. Before upgrading, write down all configuration settings of the ATS Remote Annunciator. These settings may have to be made after the upgrade is completed.

1. Write down all configuration settings.
2. Click **Browse**, then click the file with **.spb** extension.
3. Click **Upgrade**. See Figure 6.



**Figure 6: Firmware update screen**

**NOTICE**

Before updating the firmware, write down all configuration settings.

**2-3 IP Address, Subnet Mask, Gateway**

1. The default IP address parameter is: 169.254.1.200. If the ATS Remote Annunciator is on a LAN, enter an available IP address (from your network administrator). The ATS Remote Annunciator's IP address must not conflict with any other Ethernet device on the network. The default subnet mask parameter is: 255.255.255.0, and the gateway address is blank.

2. Write the IP address here \_\_\_\_\_.
3. Write the Subnet Mask here \_\_\_\_\_.
4. Write the Gateway Address here \_\_\_\_\_.

**2-4 Port**

The TCP/IP port must match the port used in the Connectivity Module (manual 381333-238). The default port is 10001 for ASCO Bus; port 502 is typically used for Modbus.

Write the port number here \_\_\_\_\_.

**2-5 Encryption**

Click **Enable** to turn on encryption or click **Disable** to turn it off. The default configuration is **Disable** (off). The Connectivity Module (CM) must also have encryption selected.

Write which option is selected here \_\_\_\_\_.

This feature is only available with encrypted-enabled CMs. All other devices communicating with the CM must be able to read the encrypted data.

**2-6 Audible Alarm (buzzer) Mode**

Operation of the audible alarm can be configured. In the **Buzzer Mode** list, click **Disable** to turn it off (it will be inactive or silent even if an alarm occurs). Click **Periodic** or **Continuous** to turn on the audible alarm. The default setting is **Continuous**. See Figure 7.

Write which option is selected here \_\_\_\_\_.

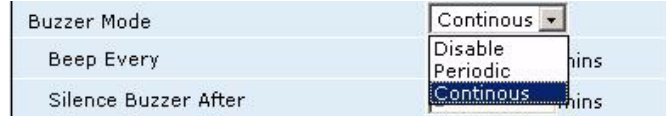

**Figure 7: Audible Alarm (buzzer) Mode**

In the **Continuous** mode the pulsing buzzer sounds continuously (on-off cycles). In the **Periodic** mode the duration of the pulses and interval between pulses can be set as follows:

Beep Every (On Time)	0-60
minutes	
Silence Buzzer After (Off Time)	0-2400
minutes	

See Figure 8.

**2-7 Beep Every (On Time)**

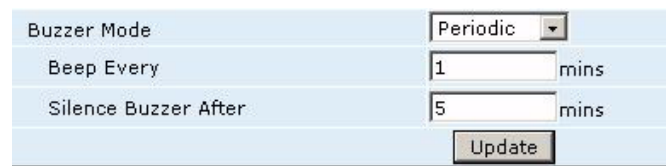

**Figure 8: Audible Alarm (buzzer) ON - OFF Times**

Buzzer total ON time: it is the total time in which the buzzer ON-OFF cycle will repeat in periodic mode from the time the buzzer alarm is initiated. This time period needs to be entered in the **Beep Every** text box. The acceptable range of Buzzer ON time is between 0 to 60 minutes, fractional values are not acceptable. Buzzer silences only if alarm condition ceases or **Buzzer On** time elapses, whichever occurs first.

**2-8 Silence Buzzer After (Off Time)**

If the Buzzer on time is set to zero, the buzzer ON-OFF cycle repeats infinitely unless the alarm condition ceases or silence alarm key is pressed.

The period of each buzzer ON-OFF cycle: It is the period after which the Buzzer ON-OFF cycle repeats. This time period needs to be entered in the **Silence Buzzer After** text box. The acceptable range of the period is between 0 to 2400 minutes. Fractional values are not acceptable. ON time in each of these cycles is fixed at one second.

**2-9 Click Update to Save Configurations !**

**Be sure to click UPDATE to save the configuration settings and upload them to the ATS Remote Annunciator.**

# ATS Configuration

The ATS Remote Annunciator must be configured for the ATS that will be monitored and controlled. First log in. The ATS Remote Annunciator sends HTML files to the client computer. *Internet Explorer* interprets these HTML files, formats them, and displays the pages to the user.

## 1 Login Screen

To login follow these steps:

1. Be sure that the computer is still connected to the Ethernet switch (LAN).
2. Start the *Internet Explorer* browser on the computer.
3. In the address bar, type in the address of the ATS Remote Annunciator, then press **Enter**:  
http://169.254.1.200
4. The ATS Remote Annunciator login page should appear. Enter the default Login ( admin ) and Password ( ASCO ) from the label (see page 2) and click **Login**. See Figure 9.



Figure 9: Login screen

## 2 ATS Configuration

5. On the left pane, under *Configurations*, click *ATS* to configure the ATS that will be monitored. See Figure 10.

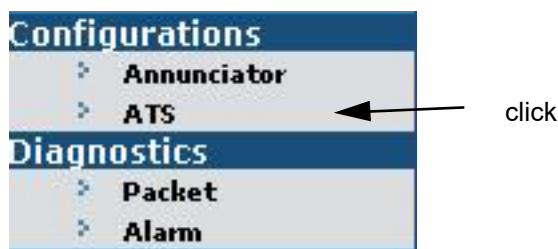

Figure 10: Configurations > ATS

For 7000, 4000 Series ATSs select *G5/ASCO2*. *ASCO2* is for baud rate 19.2K (*ASCObus 2*). For *Modbus*, see *Notes* below. All ATSs must use the same protocol. Refer to *G5 User's Guide 381333-126*.

For Series 185 or Series 300 ATSs select *G1/ASCO2*. In the Group 1 Controller, visually determine the dash number on the micro-processor's label (dash number 9 and higher is *ASCObus 2*). All ATSs must use the same protocol.



Figure 11: *Controller/Protocol* manual selection

Select the appropriate address that is set in the ATS controller (*G1* or *G5*).



Figure 12: *Controller Address* manual selection

If *G1/ASCO2* or *G5/ASCO2* protocol is selected (Figure 11), the Power Manager (*PM*) address must be the same as the address set in the corresponding ATS controller.

If *G5/Modbus* protocol is selected (Figure 11), the *PM Address* should not be the same as the address set in the ATS's Group 5 controller. They must have different addresses.



Figure 13: *PM Address* manual selection

**Modbus Notes:** The password entered (Figure 20) for the ATS must be the same as the password set in that ATS's Group 5 controller. Transfer control from the ATS Remote Annunciator will not function without the proper password. Refer to *User's Guide 381333-126*.

- When the ATS configuration is made, click **Save** to upload the configuration to the ATS Remote Annunciator. An *Uploaded Successfully* screen should appear. See Figure 14. The ATS Remote Annunciator should now be monitoring the ATS (observe the status lights).

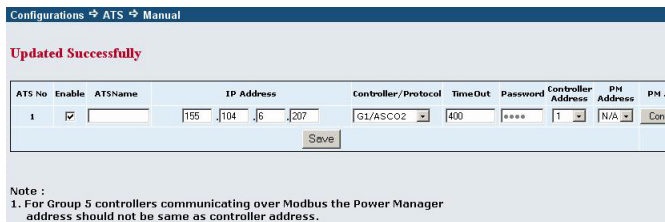

Configurations → ATS → Manual

**Updated Successfully**

ATS No	Enable	ATSName	IP Address	Controller/Protocol	TimeOut	Password	Controller Address	PM Address	PM A
1	<input checked="" type="checkbox"/>		155.104.16.207	G1/ASCO2	400	****	1	N/A	Confir

Save

Note :  
1. For Group 5 controllers communicating over Modbus the Power Manager address should not be same as controller address.

**Figure 14: Updated Successfully screen**

## 2-2 Configuring Power Manager Alarms

If a Power Manager (PM) is provided with an ATS, the PM's eight Status Inputs can be configured to signal an alarm at the ATS Remote Annunciator. At the PM, the Status Input must be set to ACTV (on). Refer to PM manual 381333-199.

- Be sure that a *PM Address* has been set (Figure 13). Then click the **Configure** button (Figure 14) next to *PM Address*.
- The first row (top) is for PM Status Input 1. Click *Enabled*.
- Next, enter a name in the *Digital Input* column, if desired.
- Repeat steps 2 and 3 for each PM Status Input that is ACTV (on). The second row is *Status Input 2*, etc. See Figure 15.
- Click the **Update** button to save these configurations.
- Click the **Save** button to save all configurations to the ATS Remote Annunciator. See Figure 14.

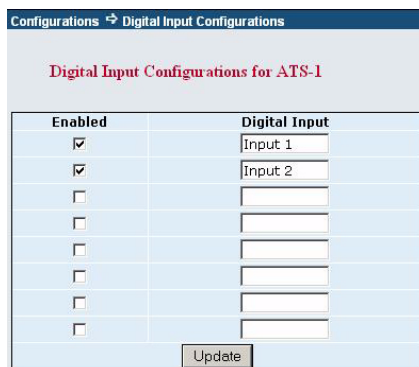

Configurations → Digital Input Configurations

**Digital Input Configurations for ATS-1**

Enabled	Digital Input
<input checked="" type="checkbox"/>	Input 1
<input checked="" type="checkbox"/>	Input 2
<input type="checkbox"/>	
<input type="checkbox"/>	
<input type="checkbox"/>	
<input type="checkbox"/>	
<input type="checkbox"/>	
<input type="checkbox"/>	

Update

**Figure 15: PM Status Input configuration**

# Diagnostics

Diagnostics can be used to check communication packets and to check for ATS alarms (to determine why the *Alarm* light is on).

If necessary, reconnect the laptop computer that was used to configure the ATS Remote Annunciator. Then log in as described on page 5.

## 1 Packets

On the left pane, under *Diagnostics*, click *Packet* to check send and receive packets from the Connectivity Module to the ATS Remote Annunciator. See Figure 16.

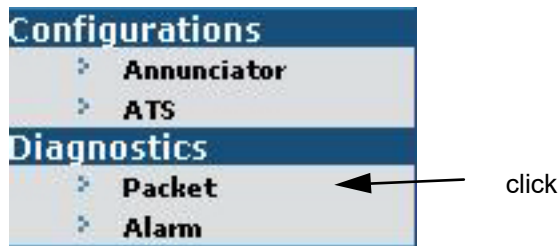

Figure 16: Diagnostics > Packet

The *Diagnostics > Packet* screen shows the ATS. It lists the *ATS No.*, *ATS Name*, *IP Address*, *Device Type* (controller/protocol), *Packets Sent* (TX), *Packets Received* (RX), and *Packets Dropped*. The number of packets dropped indicates the communication quality (lower is better). To reset the counters, click the **Reset** button. See Figure 17.

ATS No	ATS Name	IP Address	Device Type	Packets TX	Packets RX	Packets Dropped	Reset Counters
1	ATS1	192.168.174.242	G5/ASCO2	23589	23580	9	<input type="button" value="Reset"/>

Figure 17: Diagnostics > Packet screen

## 2 Alarm

On the left pane, under *Diagnostics*, click *Alarm* to see the status of all ATS alarms that are configured. See Figure 18.

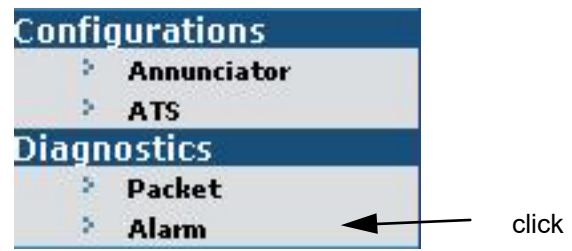

Figure 18: Diagnostics > Packet

The *Diagnostics > Alarm* screen shows these ATS alarms: *Communication Error*, *ATS Locked Out* (7ADTS, 4ADTS), *Failure to Synchronize* (7ACTS, 4ACTS), and *Extended Parallel* (7ACTS, 4ACTS). See Figure 19.

Based upon which alarm has occurred, specific action can be taken. See **Troubleshooting**.

ATS No	ATS Name	IP Address	Controller Type/Protocol	Communication Error	ATS Locked Out	Fail To Synch	Extended Parallel	ATS-PM Alarm
1		192.104.6.207	G1/ASCO2	-	-	-	-	<input type="button" value="ON"/>

Figure 19: Diagnostics > Alarm screen

If a Power Manger (PM) has been configured for Status Input alarms, click the **ON** button to see their status. For each *Digital Input*, the *Alarm Enabled* will show *INAC* for not enabled or *ACTV* for enabled. *ACTV* means the ATS Remote Annunciator is configured to accept a PM input alarm. In the *Status* column, *OFF* means there is no alarm; *ON* means there is an alarm (status input). See Figure 20.

Digital Input	Alarm Enabled	Status
Input1	INAC	OFF
Input2	INAC	OFF
Input3	INAC	OFF
Input4	INAC	OFF
Input5	INAC	OFF
Input6	INAC	OFF
Input7	INAC	OFF
Input8	INAC	OFF

Figure 20: PM Status Input alarm status

If an audible alarm is sounding at the ATS Remote Annunciator, it can be silenced (see User's Guide 381333-316). But the alarm will not reset until it is corrected at the source (PM status input).

# Troubleshooting

Number	Symptom	Probable Cause	Recommended Action
1	Power ON light is off	The DC or AC power source is inadequate or off.	Restore the DC or AC power supply. Check the terminals, fuse, circuit breaker.
2	The power ON light is blinking.	The unit keeps on resetting due to watchdog-reset possibly due to corruption of software.	Try to reprogram the unit with the latest software.
			Contact ASCO Services for replacement. 800-800-ASCO or customer@ascopower.com
3	<b>Transfer</b> button does not work (load transfer does not occur).	Button not held long enough.	Hold the button for at least 5 seconds until you hear a beep.
		ATS Annunciator could have changed to default settings.	Use the configuration details entered on page 2; reconfigure the ATS Annunciator.
4	Buzzer is beeping continuously.	Communication with the Power Manager may have stopped.	Refer to Installation Manual 381333-315. Check the Ethernet connections: ATS Annunciator to the LAN and Power Manager to the LAN.
5	Communication alarm occurs but all configurations are correct.	Communication protocol may not be the same as that of the Power Manager (if present).	Verify that the protocol on both devices is the same.
6	A light does not come on when a corresponding button is pressed.	ATS Annunciator is not functioning properly.	Contact ASCO Services for replacement. 800-800-ASCO or customer@ascopower.com

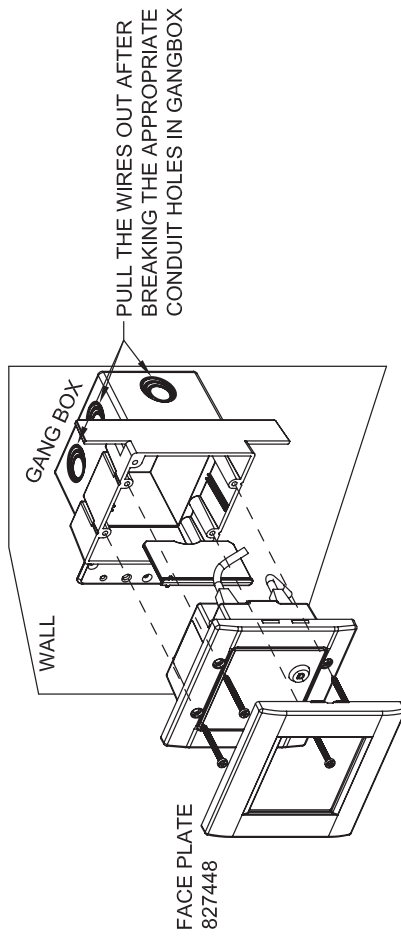

SNAP FIT THE FACE PLATE AFTER MOUNTING THE PRODUCT TO GANG BOX.

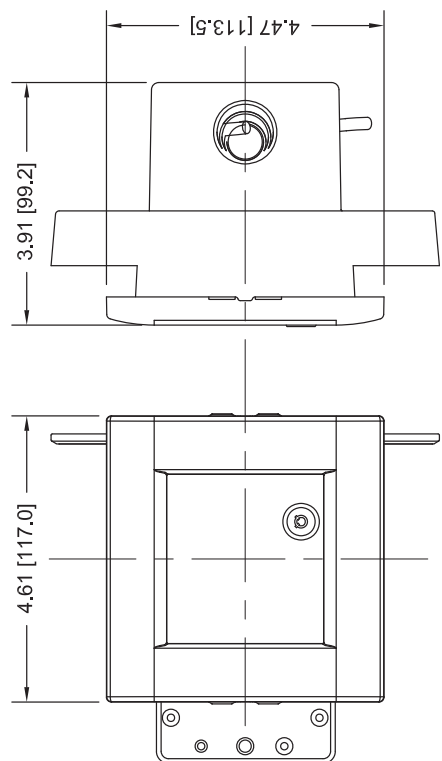

**PRODUCT DIMENSIONS**

**INSTALLATION SEQUENCE:**

1. REMOVE THE FACEPLATE FROM THE BEZEL BY FLIPPING THE SNAPS CAREFULLY.
2. PULL THE WIRES AND MAKE CONNECTIONS AS PER WIRING DIAGRAM.
3. FIX THE DIVIDER PLATE ONTO THE REAR COVER OF ANNUNCIATOR.
4. INSERT THE ANNUNCIATOR INTO THE GANG BOX OPENING.
5. TIGHTEN THE SCREWS TO FIX THE PRODUCT.
6. FIX THE FACE PLATE SUCH THAT PRODUCT LOGO APPEARS AT TOP SIDE.

**NOTES:**

1. UNLESS OTHERWISE SPECIFIED DIMENSIONS ARE IN INCH [mm].
2. RECOMMENDED GANG BOXES: A238, BH234R, B232B-UPC, B225R-UPC, BH235, CARLON MAKE OR EQUIVALENT UL RATED GANG BOX.

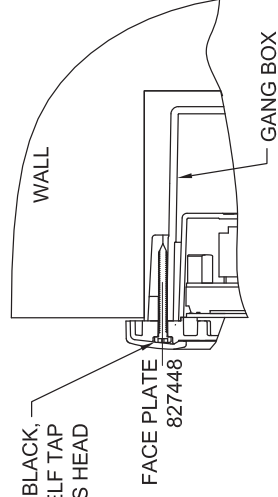
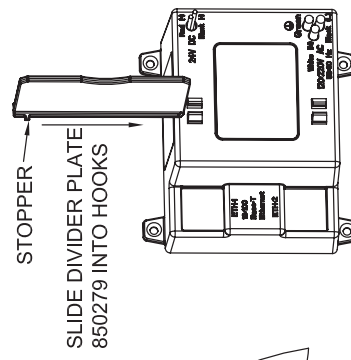
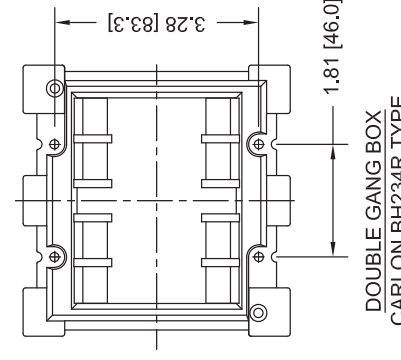
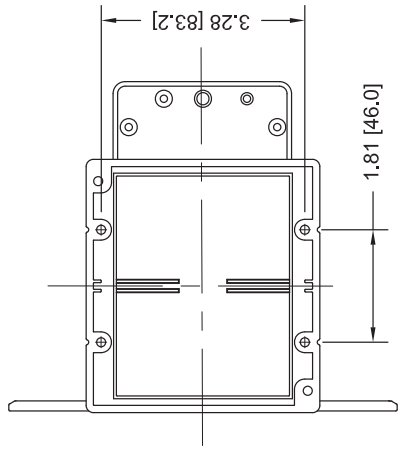

ENSURE DIVIDER PLATE (850279) IS INSTALLED BEFORE MOUNTING THE ANNUNCIATOR FOR ELECTRICAL SAFETY

A	223488	JAV	JEH	08/09
	ADD	MANUAL	P/N	
—	221797	SRC	JEH	02/09
	NEW	ISSUE		
REV. TO SHEET	ECN NO.	BY	APP.	DATE

USED ON INSTALLATION MANUAL 381333-317

PROJECT NAME: XD-1047-1CH		COMPUTER GENERATED DRAWING	
INSTALLATION DRAWING		SCALE: 1:1	SIZE: BS
ATS REMOTE ANNUNCIATOR - 1 CH		DWG. NO.	834979
BY: CHL	DATE: 09/07	ASSEM. REF. NO.	—
CHECKED: JAV	DATE: 05/08	MANUFACTURING TOLERANCES TO BE IN ACCORDANCE WITH ASSEMBLY DRAWING FOR PLASTIC PARTS SEE MP-1-055	
PROJECT APPROVAL: JEH	DATE: 05/08	PROPERTY OF ASCO POWER TECHNOLOGIES. USE PERMITTED FOR OUR WORK ONLY. ALL RIGHTS OF DESIGN OR INVENTION ARE RESERVED.	
FINAL APPROVAL: JEH	DATE: 05/08	 <b>ASCO</b> ® ASCO POWER TECHNOLOGIES, L.P. FLOHAM PARK, NEW JERSEY 07932 U.S.A.	
		DRAWING A	ECN 223488
			SHEET 1 OF 2

## Overall Communication Architecture

### Architecture 1 Single ATS Connected to Single Connectivity Module

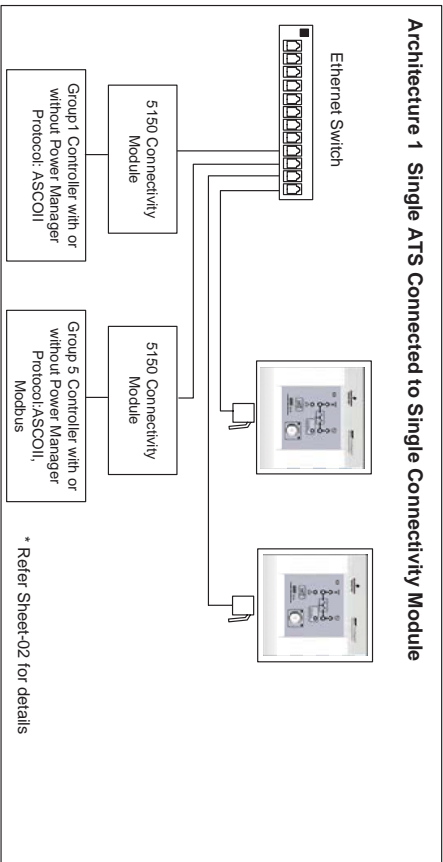

#### Ethernet Cable Pinout

Pin	Pair	Wire	Color
1	2	1	White /Orange
2	2	2	Orange
3	3	1	White /Green
4	1	2	Blue
5	1	1	White /Blue
6	3	2	Green
7	4	1	White /Brown
8	4	2	Brown

#### General Notes

Note	Description
1	Each Ethernet device must be configured with its own unique IP address on the network.

Sheet Number	Description of Wiring Diagram
1	Overall Communication architecture
2	Architecture 1 Reference Wiring Diagram
3	Architecture 2 Reference Wiring Diagram
4	Power supply and other wiring diagram

LED Label	LED Description	LED Function
POWER	Power on indication Green	Solid ON indicates application software is running
	LED 1 Green	Solid Green ON indicates network operating at 100Mbps Speed, Full duplex with no collision
	LED 1 Orange	Blinking Green indicates network operating at 100Mbps Speed, Full duplex with collision
ETH1 & ETH2	LED 1 Orange	Blinking Orange indicates network operating at half duplex with collision
	LED 1	LED1 is OFF indicates speed and Full duplex/Col signals are not active
	LED 2 Green	Green Blink when Link and Act signals present and indicates TX/RX signals activities
	LED 2 Orange	Solid Orange ON indicates Link is present but no Act signal
	LED 2	LED2 is OFF indicates Link and Act signals are not active

### Architecture 2 - Serial RS-485 Support via Connectivity Module

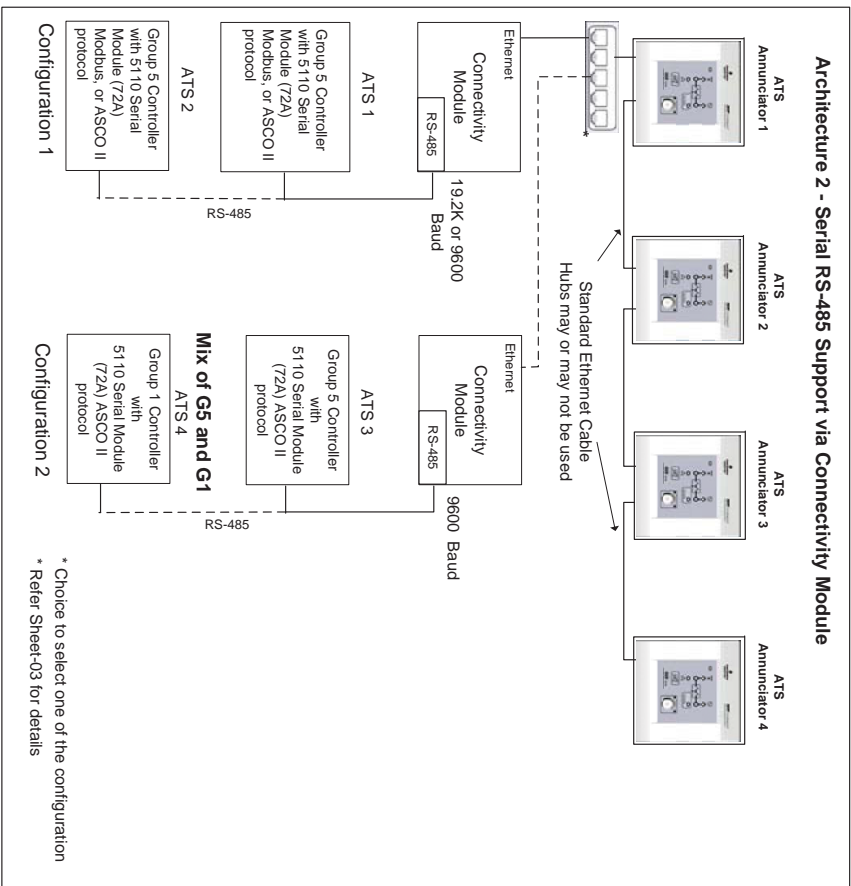

PROJECT NAME: XD-1047 - 1CH		DRAWING NO. 827420	
WIRING DIAGRAM		DIAGRAM	
ATS REMOTE ANNUNCIATOR - 1CH		THIRD ANGLE PROJECTION	
CAT. 5310		ASSEMBLY REF. NO.	
BY	DATE	PROPERTY OF ASCO POWER TECHNOLOGIES, L.P. USE PERMITTED FOR OUR WORK ONLY. ALL RIGHTS OF DESIGN OR INVENTION ARE RESERVED.	
JAV	02/09	SCALE NONE	
SRC	02/09	SIZE DWG NO.	
JEH	02/09	FILE	
FINAL APPROVAL		COMPUTER GENERATED DRAWING	
ASCO Technologies, L.P. FLORHAM PARK, NJ USA 07932		CHANGE LETTER A	
		ECON NO. XXXXXX	
		SHEET 1 of 4	

## Power supply diagram

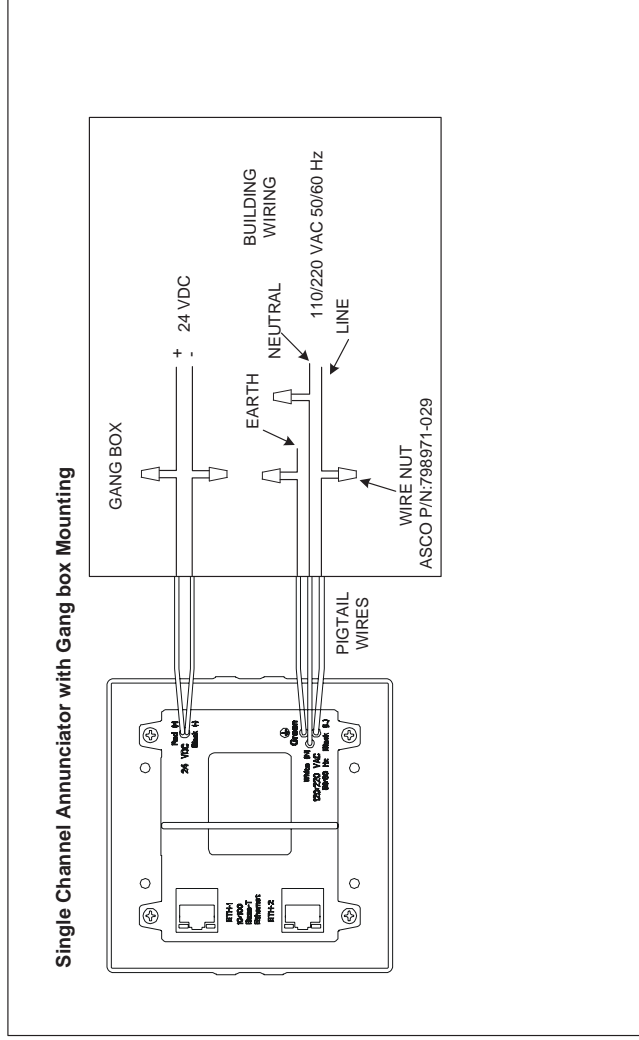

Wire Description	Color	Connection
Stranded wire #18AWG(16/30)	White	Neutral
	Black	Line
	Green	Earth
Insulated Solid Conductor wire #20AWG	Red	24 VDC +
	Black	GND -

Table B

## Notes

- Warning:** Before making the connections ensure the mains power is disconnected from the accessible wiring.
- Power and communication cables shall be routed in the gang box to maintain a minimum of 1/4" (6mm) separation as per NFPA 800.133 Exception 2.
- Install the Voltage divider plate provided to ensure the separation of power and communication cables.
- Refer Table B for wire color, for proper connections.
- The pig tail wires has pre-installed sleeve, open it only if that connection needs to be made.
- The insulation of wires intended to connect shall only be opened for others wires the insulation shall be intact.

PROJECT NAME: XD-1047 - TCH		WIRING DIAGRAM		INSTALLATION	
BY: JAV		DATE: 02/09		THIRD ANGLE PROJECTION	
CHECKED: JAV		DATE: 02/09		ASSEMBLY REF. NO. 827420	
DRAFTING APPROVAL: SRC		DATE: 02/09		MANUFACTURING TOLERANCES TO BE IN ACCORDANCE WITH ASCO PROCEDURE MP-H003 FOR PLASTIC PARTS SEE MP-H005	
FINAL APPROVAL: JEH		DATE: 02/09		PROPERTY OF ASCO POWER TECHNOLOGIES, L.P. USE PERMITTED FOR OUR WORK ONLY. ALL RIGHTS OF DESIGN OR INVENTION ARE RESERVED.	
SCALE: None		DWG. NO. 850281		COMPUTER GENERATED DRAWING	
CHANGE LETTER		ECN NO.		BY	
A		A		APPD	
CHANGE LETTER		ECN NO.		DATE	
BS		A			
ASCO Power Technologies, L.P.		FLORHAM PARK, NJ USA 07932		SHEET 4 of 4	

# Index

## A

address  
     controller, 7  
     IP, 3, 4, 5, 6, 9  
 alarm, 9  
 alarm buzzer, 3  
 alarm light, relay  
 alarm silence button, refer to  
     User's Guide 381333-316  
 ATS configuration, 7-8  
 ATS controller, 7  
 ATS name, ATS no., 9

## B

bezel release, 3  
 buttons, refer to  
     User's Guide 381333-316  
 buzzer configuration, 3, 5  
 bypass (cancel) transfer time delay,  
     refer to User's Guide 381333-  
 316

## C

change password, 5  
 communication architecture, 2  
 communication check, 4  
 Configurations,  
     ATS configuration, 7-8  
     ATS Remote Annunciator,  
 5-6  
 connections, 3, wiring diagram  
 850281  
 Connectivity Module (CM) 5150,  
     6, 9, refer to Installation  
     Manual 381333-238  
 control key switch, 4  
 controller, ATS, 7  
 controller address, 7  
 controller protocol, 7

## D

diagnostics, 9  
 digital input, 9

## F

factory default information, 3  
 firmware update, 6  
 functional test, 4

## G

gateway address, 5, 6

## H

HELP, 800-800-2726 (ASCO),  
     customer@ascopower.com

## I

initial checks, 4  
 installation, 3  
 installation drawings, 834979 sheet  
 1  
 Internet Protocol, 4  
 IP address, , 3, 4, 5, 6, 9

## K

key switch, Control, 4, refer to  
     User's Guide 381333-316

## L

lights, 1, 8, refer to  
     User's Guide 381333-316  
 login, 3, 4

## M

mounting, 3  
     installation drawing 834979

## N

name, Login, 5

## O

operation, refer to  
     User's Guide 381333-316

## P

packet, 9  
 password, 2, 3  
 port number, 6  
 Power Manager (PM), 7, 8  
 power on light, 10  
 power wiring, 3, wiring diagram  
 850281  
 problem, 10  
     800-800-2726 (ASCO),  
     customer@ascopower.com

## R

reboot, reset, refer to  
     User's Guide 381333-316

## S

save configuration, 6  
 select an ATS configuration, 7  
 specifications, 3  
 software upgrade, version, 5  
 subnet mask, 3, 4, 5, 6

## T

time delay, transfer, bypass  
 (cancel),  
     refer User's Guide 381333-  
 316  
 Transfer button, refer to  
     User's Guide 381333-316  
 troubleshooting, 10

## U

update, save configuration, 5  
 update, firmware, 6  
 User's Guide, 1, 381333-316