



Model 520



Model 515



Model 510

**Model 520**  
**Model 515**  
**Model 510**

**ASCO SURGE PROTECTIVE DEVICE  
INSTALLATION, OPERATION AND MAINTENANCE MANUAL**

**TABLE OF CONTENTS**

<b>UNPACKING AND INSTALLATION</b>	
Unpacking and Preliminary Inspection.....	3
Handling Considerations.....	3
Storage.....	3
<b>LOCATION CONSIDERATIONS</b>	
Environment .....	3
Audible Noise.....	3
Service Clearances.....	3
Mounting.....	3
Warnings Defined.....	3
<b>MODEL NUMBER CONFIGURATION</b>	
Model Number Configuration.....	4-5
<b>SPD WIRING AND MOUNTING</b>	
Voltage Ratings and Power Source Configurations.....	6
Wire Connections.....	6
Over Current Protection.....	6
NEC Considerations.....	6
Voltage Protection Rating.....	7
Circuit Ampacity Limitations.....	7
System Grounding and Bonding.....	7
Grounding Electrode.....	7
Neutral Connection.....	7
Parallel Connection / Wire Diagram .....	7
<b>INSTALLATION INSTRUCTIONS</b>	
Product Installation.....	3
Model 520.....	3
Model 510.....	3
Model 515.....	3
<b>MONITORING FEATURES</b>	
External Status Indicators (Standard).....	6
Audible Alarm (Standard/Optional).....	6
Summary Alarm Contact (Standard/Optional).....	6
Transient Counter (Optional).....	6
<b>TROUBLESHOOTING/SERVICING/MAINTENANCE</b>	
Troubleshooting .....	6
Servicing.....	6
Corrective Maintenance.....	6
Preventative Maintenance.....	6

**CALIFORNIA CUSTOMERS - PROP 65 WARNING**

**⚠ WARNING:** This product can expose you to chemicals including DINP, which is known to the State of California to cause cancer, and DIDP, which is known to the State of California to cause birth defects or other reproductive harm. For more information go to [www.P65Warnings.ca.gov](http://www.P65Warnings.ca.gov).

## UNPACKING AND INSTALLATION

### Unpacking and Preliminary Inspection

1. Inspect the shipping crate(s) for damage or signs of mishandling before unpacking the unit.
2. Remove any securing bands and cardboard packing and inspect the unit for any obvious shipping damages.
3. If any damage as a result of shipping is observed, immediately file a claim with the shipping agency and forward a copy to your local ASCO Surge Protection Sales Representative.

**Handling Considerations:** Larger units are bolted to a shipping pallet to facilitate handling by forklift or pallet jack. Check the size and weight. Refer to the cabinet data furnished with the unit.

**Storage:** The unit should be stored in a clean, dry environment. Storage temperature range is 0°C (+32°F) to +40°C (+104°F). Care should be taken to avoid condensation. All packing and shipping materials should be left intact until the unit is ready for final installation. If the unit has been stored for an extended period of time, the unit should be cleaned and carefully inspected before placing into service.

### LOCATION CONSIDERATIONS

For optimum transient surge protection, coordinated surge suppression should be applied at the service entrance and all other electrical connections to the building (telephone, CATV, etc.), at known surge generating loads within the building (large motors, arc welders, switched capacitors, etc.), as well as at sensitive electronic loads (such as computers, electronic appliances, solid state motor drives, etc.). For interconnected electronic loads (such as by way of data cabling), transient surge suppression should also be applied to the interconnecting wiring (data cables).

**Environment:** Unit is designed for operation indoors in ambient temperatures of 0°C (+32°F) to +40°C (+104°F) with a relative humidity of 0% to 95% (non-condensing).

The unit is provided in an industrial use enclosure, which is dust-tight and drip-tight and should not be installed in areas with excessive dust, corrosive vapors, flammable materials or explosive atmospheres.

**Audible Noise:** The audible noise of the unit is less than 40 dB at 5 feet, which allows its placement within almost any room if desired.

**Service Clearances:** Service clearance is needed for units with hinged doors on the front that are capable of being opened. Thirty-six inches (36 in/914 mm) minimum is recommended.

**Mounting:** Unit is intended to be wall mounted. Refer to installation instructions for mounting dimensions and weight.

### Warnings Defined:



**DANGER!** INDICATE[S] A HAZARDOUS SITUATION WHICH, IF NOT AVOIDED, WILL RESULT IN DEATH OR SERIOUS INJURY. THE SIGNAL WORD "DANGER" IS TO BE LIMITED TO THE MOST EXTREME SITUATIONS. DANGER [SIGNS] SHOULD NOT BE USED FOR PROPERTY DAMAGE HAZARDS UNLESS PERSONAL INJURY RISK APPROPRIATE TO THESE LEVELS IS ALSO INVOLVED.

**DANGER!** INDIQUE UNE SITUATION DANGEREUSE QUI, SI ELLE N'EST PAS ÉVITÉE, ENTRAÎNERA LA MORT OU DES BLESSURES GRAVES. LE MOT COMME SIGNAL «DANGER» DOIT ÊTRE LIMITÉ AUX SITUATIONS LES PLUS EXTRÊMES. LES SIGNES DANGER NE DOIVENT PAS ÊTRE UTILISÉS POUR LES RISQUES DE DOMMAGES À LA PROPRIÉTÉ, SAUF SI LE RISQUE DE BLESSURES APPROPRIÉES À CES NIVEAUX EST ÉGALEMENT IMPLIQUÉ.

## **WARNING**

**WARNING! INDICATE[S] A HAZARDOUS SITUATION WHICH, IF NOT AVOIDED, COULD RESULT IN DEATH OR SERIOUS INJURY. WARNING [SIGNS] SHOULD NOT BE USED FOR PROPERTY DAMAGE HAZARDS UNLESS PERSONAL INJURY RISK APPROPRIATE TO THIS LEVEL IS ALSO INVOLVED.**

**AVERTISSEMENT! INDIQUE UNE SITUATION DANGEREUSE QUI, SI ELLE N'EST PAS ÉVITÉE, POURRAIT ENTRAÎNER LA MORT OU DES BLESSURES GRAVES. LES SIGNES AVERTISSEMENT NE DOIVENT PAS ÊTRE UTILISÉS POUR LES RISQUES DE DOMMAGES À LA PROPRIÉTÉ, SAUF SI LE RISQUE DE BLESSURES APPROPRIÉES À CE NIVEAU EST ÉGALEMENT IMPLIQUÉ.**

## **CAUTION**

**CAUTION! INDICATE[S] A HAZARDOUS SITUATION WHICH, IF NOT AVOIDED, COULD RESULT IN MINOR OR MODERATE INJURY. CAUTION [SIGNS] WITHOUT A SAFETY ALERT SYMBOL MAY BE USED TO ALERT AGAINST UNSAFE PRACTICES THAT CAN RESULT IN PROPERTY DAMAGE ONLY.**

**ATTENTION! INDIQUE UNE SITUATION DANGEREUSE QUI, SI ELLE N'EST PAS ÉVITÉE, POURRAIT ENTRAÎNER DES BLESSURES MINEURES OU MODÉRÉES. LES SIGNES ATTENTION SANS SYMBOLE D'ALERTE DE SÉCURITÉ PEUVENT ÊTRE UTILISÉS POUR METTRE EN GARDE CONTRE DES PRATIQUES DANGEREUSES QUI PEUVENT ENTRAÎNER DES DOMMAGES MATÉRIELS SEULEMENT.**

### **ELECTRICAL CONNECTIONS**

All wiring must comply with the National Electrical Code (NEC) and applicable local codes.

## **DANGER**

**DANGER! ONLY QUALIFIED PERSONNEL SHOULD INSTALL OR SERVICE THIS SYSTEM. ELECTRICAL SAFETY PRE-CAUTIONS MUST BE FOLLOWED WHEN INSTALLING OR SERVICING THIS EQUIPMENT. TO PREVENT RISK OF ELECTRICAL SHOCK, TURN OFF AND LOCK OUT ALL POWER SOURCES TO THE UNIT BEFORE MAKING ELECTRICAL CONNECTIONS OR SERVICING.**

**DANGER! SEULEMENT LE PERSONNEL QUALIFIÉ DOIT INSTALLER OU MAINTENIR CE SYSTÈME. DES PRÉCAUTIONS DE SÉCURITÉ EN ÉLECTRICITÉ DOIVENT ÊTRE SUIVIS LORS DE L'INSTALLATION OU DE LA MAINTENANCE DE CET ÉQUIPEMENT. POUR ÉVITER TOUT RISQUE DE CHOC ÉLECTRIQUE, DÉBRANCHEZ ET VEROUILLER TOUTES LES SOURCES D' ALIMENTATION DE CET ÉQUIPEMENT AVANT DE LE BRANCHER OU LE MAINTENIR.**

**Voltage Ratings and Power Source Configurations:** Before making connections to the unit, verify that the unit model number and nameplate voltage rating are appropriate for connection to the intended power source. See the chart on page 3 for voltage rating applications with typical power source configurations.

**Wire Connections:** With parallel connection, the size of the wiring to the SPD unit is independent of the protected circuit's ampacity. NEC Article 285-21(B) requires surge suppressor connecting conductors to be at least #14 copper or #12 aluminum. To reduce the wiring impedance to surge currents, it is recommended that the phase, neutral (if required), and ground conductors are twisted together and routed in the same raceway (conduit). Avoid any sharp bends in the conductors.

**Overcurrent Protection:** The SPD unit conducts practically no current under normal operation and only conducts very short duration transient surge currents.



# Model 515 Number Configurator & Options

## 515

Model 515  
Product Line

Voltage Codes

P

Per Phase  
kA Rating  
System

kA Rating  
Per Phase

A

Modes of  
Protection

C

Connection  
Type

Monitoring  
Options

Enclosure

2

UL 1449  
Type 2

Post Part Number  
Accessory/Option(s)

### Common Systems

- 120S = 240/120V Split Phase - 1Ø, 3W+Grnd, (Fig 1)
- 120Y = 208Y/120V Wye - 3Ø 4W+Grnd, (Fig 2)
- 240H = 240/120V High Leg Delta (B High), (Fig 3)
- 277Y = 480Y/277V Wye - 3Ø 4W+Grnd, (Fig 2)

### Other Available Systems - Confirmation Encouraged

- 120N = 120V Single Phase (Fig 5)
- 127N = 127V Single Phase (Fig 5)
- 127S = 254/127V Split Phase - 1Ø, 3W+Grnd, (Fig 1)
- 127Y = 220Y/127V Wye - 3Ø, 4W+Grnd (Fig 2)
- 208D = 208V Delta - 3Ø, 3W+Grnd (Fig 4)
- 220N = 220V Single Phase (Fig 5)
- 230Y = 400Y/230V Wye - 3Ø 4W+Grnd (Fig 2)
- 230N = 230V Single Phase (Fig 5)
- 240N = 240V Single Phase (Fig 5) - Not split phase
- 240Y = 415Y/240V Wye - 3Ø 4W+Grnd (Fig 2)
- 240C = 240V B Corner Grnd Delta, 3Ø 3W+Grnd (Fig 6)
- 240D = 240V Delta - 3Ø 3W+Grnd (Fig 4)
- 254N = 254V Single Phase (Fig 5)
- 254Y = 440Y/250V Wye - 3Ø 4W+Grnd (Fig 2)
- 277N = 277V Single Phase (Fig 5)
- 277S = 480/240V Split Phase, or Two legs of Wye, (Call)
- 480H = 480/240V High Leg Delta (B High), (Fig 3)

A = All Standard  
Modes for  
that Voltage  
Code (Default)

Delete Mode  
Options & Alt.  
Configurations:  
Contact Factory

C = Compression  
Lugs (Default)

- 13 = 130kA Per Phase  
(65kA Per Mode)
- 16 = 160kA Per Phase  
(80kA Per Mode)

R = Green & Red  
LEDs, Two sets  
of Dry Contacts

C = R (above) plus  
Audible Alarm  
with Silence  
Switch and  
Surge Counter

S = NEMA 1 Steel Surface  
Mount Trim  
F = NEMA 1 Steel Flush  
Mount Trim

2 = Type 2  
(Includes UL1283 Filter  
and cUL Marking for  
Canada)

0 = No Trailing  
Accessory/Option  
X = Yes, Trailing  
Accessory/Option

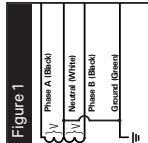

Figure 1  
SPLIT  
2 Phases, 1 Neutral,  
1 Ground

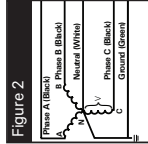

Figure 2  
WYE  
3 Phases, 1 Neutral,  
1 Ground

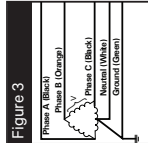

Figure 3  
HIGH LEG DELTA  
(B High) 3 Phases,  
(B High) 1 Neutral,  
1 Ground

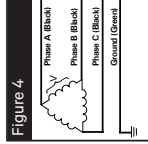

Figure 4  
DELTA & HRG WYE  
3 Phases, 1 Ground

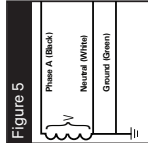

Figure 5  
SINGLE POLE  
1 Phase, 1 Neutral,  
1 Ground

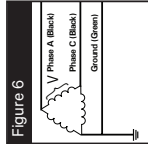

Figure 6  
CORNER GROUND  
DELTA (B Grounded)  
2 Phases, 1 Ground

# Model 520 Number Configurator & Options

**520**

Model 520  
Product Line

Voltage Codes

**P**  
Per Phase  
kA Rating  
System

kA Rating  
Per Phase

**A**  
Modes of  
Protection

Connection  
Type

Monitoring  
Options

Enclosure

UL 1449  
Type/Type 2

Accessory/  
Option(s)

## Common Systems

- 120S = 240/120V Split Phase - 1Ø, 3W+Grnd, (Fig 1)
- 120Y = 208Y/120V Wye - 3Ø 4W+Grnd, (Fig 2)
- 240H = 240/120V High Leg Delta (B High), (Fig 3)
- 277Y = 480Y/277V Wye - 3Ø 4W+Grnd, (Fig 2)
- 480D = 480V Delta - 3Ø 3W+Grnd, (Fig 4) & HRG Wye

## Other Available Systems - Confirmation Encouraged

- 120N = 120V Single Phase (Fig 5)
- 127N = 127V Single Phase (Fig 5)
- 127S = 254/127V Split Phase - 1Ø, 3W+Grnd, (Fig 1)
- 208D = 208V Delta - 3Ø, 3W+Grnd (Fig 4)
- 220N = 220V Single Phase (Fig 5)
- 220S = 440/220V Split Phase - 1Ø, 3W+Grnd, (Fig 1)
- 230Y = 380Y/220V Wye - 3Ø, 4W+Grnd (Fig 2)
- 230Y = 400Y/230V Wye - 3Ø, 4W+Grnd (Fig 2)
- 230N = 230V Single Phase (Fig 5)
- 240N = 240V Single Phase (Fig 5) - Not split phase
- 240Y = 415Y/240V Wye - 3Ø 4W+Grnd (Fig 2)
- 240C = 240V B Corner Grnd Delta, 3Ø 3W+Grnd (Fig 6)
- 240D = 240V Delta - 3Ø 3W+Grnd (Fig 4)
- 254N = 254V Single Phase (Fig 5)
- 254Y = 440Y/250V Wye - 3Ø 4W+Grnd (Fig 2)
- 277N = 277V Single Phase (Fig 5)
- 277S = 480/240V Split Phase, or Two legs of Wye, (Call)
- 400D = 300V Single Phase (Fig 5)
- 415D = 415V Delta - 3Ø, 3W+Grnd (Fig 4)
- 480C = 480V B Corner Grnd Delta - 3Ø, 3W+Grnd (Fig 6)
- 480H = 480/240V High Leg Delta (B High), (Fig 3)

**A** = All Standard Modes  
for that Voltage  
Code (Default)

Delete Mode Options &  
Alt. Configurations:  
Contact Factory

**C** = Compression Lugs  
(Default)  
**T** = Through-Door Rotary  
Disconnect Switch

**A** = LEDs/Audible  
Alarm/Relay  
**C** = LEDs/Audible  
Alarm/Relay/  
Surge Counter

**L** = NEMA 12 Steel  
(Default)  
**R** = NEMA 3R Steel  
(Display Inside Door)  
**G** = NEMA 4 Steel  
(Display Inside Door)  
**H** = NEMA 4X Stainless Steel  
(Display Inside Door)

**0** = No Trailing  
Accessory/Option  
**X** = Yes Trailing  
Accessory/Option

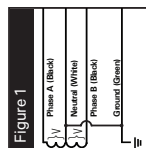

WYE  
3 Phases, 1 Neutral,  
1 Ground

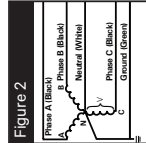

HIGH LEG DELTA  
(B High) 3 Phases,  
1 Neutral,  
1 Ground

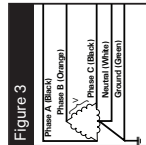

DELTA & HRG WYE  
3 Phases, 1 Ground

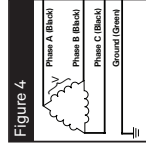

SINGLE POLE  
1 Phase, 1 Neutral,  
1 Ground

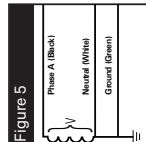

CORNER GROUND  
DELTA (B grounded)  
2 Phases, 1 Ground

**NEC Considerations:** The following is from the National Electric Code 2008 Edition.

**NEC 285.21 Connections**

**NEC 285.23 Type 1 SPDs.** Shall be installed in accordance with 285.35(A) and (B).

- A. Installation. Type 1 SPDs shall be installed as follows:
  - 1. Type 1 SPDs shall be permitted to be connected to the supply side of the service disconnect as permitted in 230.82(4) or
  - 2. Type 1 SPDs shall be permitted to be connected in Type 2 locations as specified in 285.24.
- B. At the service. When installed at the services, the grounding conductor of a Type 1 SPD shall be connected to one of the following:
  - 1. Grounded service conductor
  - 2. Grounded electrode conductor
  - 3. Grounding electrode for service
  - 4. Equipment grounding terminal in the service equipment

**Voltage Protection Ratings:** To obtain the voltage protection ratings (VPRs), as obtained by Underwriters Laboratory, Incorporated, in accordance with the *Standard for Safety, Surge Protective Devices (SPDs), Standard 1449, Fourth Edition*, marked on this product, the wire size listed for each product must be utilized to connect the unit to your facilities' power grid. Connections made with conductors other than the wire size listed may result in different VPRs.

**Circuit Ampacity Limitations:** Representative samples of these products have been investigated by Underwriters Laboratories, Incorporated to withstand, without exposing live circuits or components at system voltages and fault currents up to 200,000 AIC, as described in the *Standard for Safety, Surge Protective Devices (SPDs), Standard 1449, Fourth Edition*.

**System Grounding and Bonding:** The performance and safety of any SPD system is dependent on proper grounding and bonding. Grounding is required for safety. Correct implementation also enhances equipment performance. Incorrect grounding can reduce or impede the SPD's operation. All electrical circuits to the SPD must include an equipment- grounding conductor as required by the NEC and local codes.

An insulated grounding conductor is required in addition to any metallic raceway, which may be used as a grounding conductor. For parallel-connected SPDs, the grounding conductor should be the same wire size as the associated power conductors.

	<p><b>CAUTION! UNGROUNDED POWER SYSTEMS ARE INHERENTLY UNSTABLE AND CAN PRODUCE EXCESSIVELY HIGH LINE-TO- GROUND VOLTAGES DURING CERTAIN FAULT CONDITIONS. DURING THESE FAULT CONDITIONS ANY ELECTRICAL EQUIPMENT, INCLUDING AN SPD, MAY BE SUBJECTED TO VOLTAGES WHICH EXCEED THEIR DESIGNED RATINGS. THIS INFORMATION IS BEING PROVIDED TO THE USER SO THAT AN INFORMED DECISION CAN BE MADE BEFORE INSTALLING ANY ELECTRICAL EQUIPMENT ON AN UNGROUNDED POWER SYSTEM. CONTACT FACTORY FOR UNGROUNDED APPLICATIONS.</b></p> <p><b>ATTENTION – LES SYSTÈMES D’ALIMENTATION NON-MISES À LA TERRE SONT INTRINSÈQUEMENT INSTABLES ET PEUVENT PRODUIRE DES TENSIONS DE PHASE TRÈS ÉLEVÉES AU COURS DE CERTAINES CONDITIONS DE DÉFAUT. PENDANT CES CONDITIONS DE DÉFAUT TOUT ÉQUIPEMENT ÉLECTRIQUE, Y COMPRIS UN SPD (PROTECTEUR DE SURTENSION), PEUT ÊTRE SOUMIS A DES TENSIONS SUPERIEURES À LEURS VALEURS STANDARDS. CETTE INFORMATION EST FOURNIE À L’UTILISATEUR AFIN QU’UNE DÉCISION CORRECTE PEUT ÊTRE PRISE AVANT D’INSTALLER UN ÉQUIPEMENT ÉLECTRIQUE SUPPLIMENTAIRE SUR UN SYSTÈME D’ALIMENTATION NON-MISE À LA TERRE. CONTACTER L’USINE POUR LES APPLICATIONS NON-MISES À LA TERRE.</b></p>
--	--

Grounding conductors must be routed with the associated power conductors in the same raceway (conduit). When metallic raceways are used, adequate electrical continuity must be maintained at all raceway connections, particularly raceway terminations to the electrical enclosures. The use of isolating bushings or other means to interrupt a metallic conduit run is a potential safety hazard and is not recommended.

**Grounding Electrode:** Surge protective devices do not discharge all surges to ground (earth). Surge protective devices can also divert the surge current back to its source to complete the electrical circuit. In the case of lightning whose potential is developed with respect to the earth, the SPD diverts the surge current to the grounding electrode (earth connection). However, for most transient surges that are developed by switching loads, the SPD diverts the surge current back to its source without involving the grounding electrode.

For proper SPD performance, the service entrance grounding electrode system must comply with the NEC by having all available electrodes (building steel, metal water pipe, driven rods, concrete encased electrodes, etc.) properly bonded together and connected to the power system grounding.

The use of a separate grounding electrode to ground the SPD defeats the effectiveness of the SPD, is a potential safety hazard, may cause equipment damage, is an NEC violation (reference NEC 250-51 and 250-54), and is not recommended.

**Neutral Connection: NOTICE - FOR PROPER AND SAFE OPERATION, THE SPDs NEUTRAL MUST BE RELIABLY CONNECTED TO THE NEUTRAL OF THE SOURCE. FAILURE TO PROVIDE A RELIABLE NEUTRAL CONNECTION MAY RESULT IN FAILURE!**

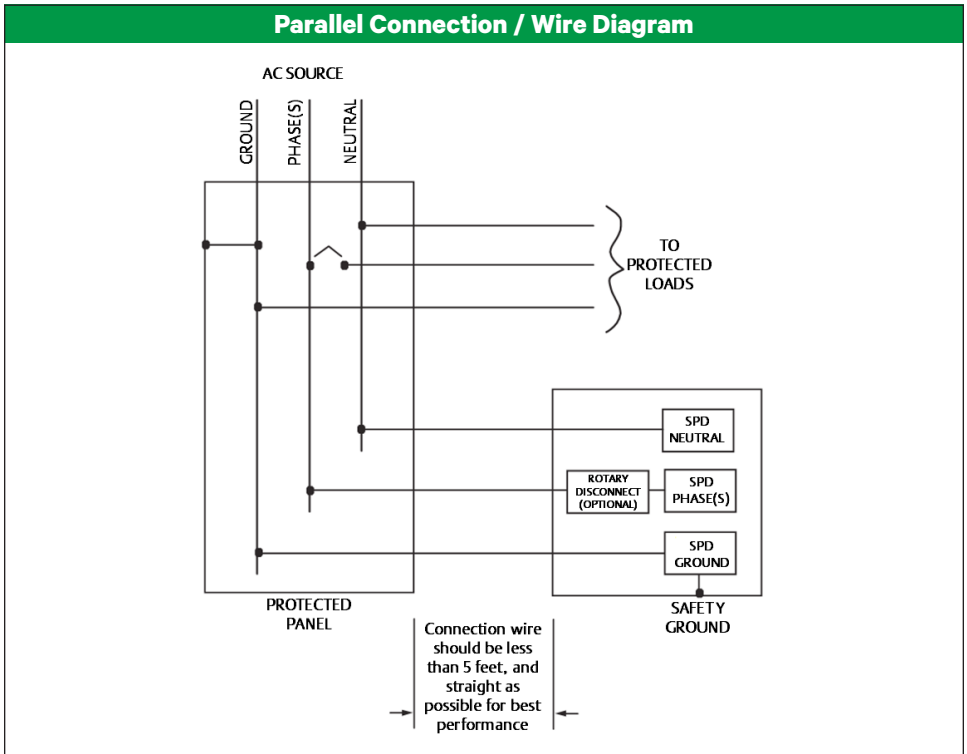

## INSTALLATION INSTRUCTIONS

The ASCO 500 SERIES Surge Protective Devices (SPDs) are high quality, high energy surge current diversion systems designed to protect sensitive equipment from damaging transient voltage surges. Proper installation is required for maximum system performance.

The installer should perform the following steps to assure a quality installation. The entire installation manual should be read before starting installation. These instructions do not replace national or local electrical codes. Check applicable electrical codes to ensure compliance. Installation of the SPD system should only be performed by qualified personnel.

1. Insure that all power is removed before beginning installation. A qualified licensed electrician shall install all electrical connections.
2. The standard SPD is provided in a 520- NEMA 12 (Indoor), 515- NEMA 1 (indoor), 510- NEMA 4X rated enclosures. Verify the SPD enclosure rating by referencing position 14 in the model number.
3. Determine where the SPD is to be mounted, allowing for minimum length of wire between itself and the input power terminals of the service panel. Punch or cut the proper hole size in the side of the SPD closest to the knockout to be utilized in the service panel (plastic NEMA 4X "J" enclosure units include a flexible conduit/nipple accessory – no punching or drilling required in SPD). Drill mounting holes in wall at location picked for SPD next to service panel using mounting dimensions shown in the table below. Mount surge suppressor to wall using appropriate size & type hardware.
4. Connect black wires (line or phase) marked L1/A, L2/B or L3/C, the white wire (neutral) marked N, and the green wire (ground) marked G, of the SPD using the wire range listed below. To yield the best performance of the SPD within the electrical distribution system, keep all conductors as short as possible and avoid sharp bends.
5. Connection to the unit's summary alarm contacts shall be with #18 – 22 AWG. The ratings of the Form 'C' contacts are 5 amps at 250 VAC maximum with a power factor of 1.0. For additional information, see "Monitoring" section.
6. Apply power. The surge protector is fully operational when the GREEN LEDs on the modules and the front door of enclosure are illuminated. If the GREEN LEDs are extinguished or a RED LED is illuminated, check to ensure that power is applied to the SPD. If an abnormal indication is present, remove power to the SPD and contact ASCO Surge Protection at: 1-800-237-4567 or 1-727-535-6339.
7. Periodically monitor the status of the LEDs. Reduced protection exists if the GREEN LEDs are extinguished or the RED LED is illuminated. Please contact ASCO Surge Protection at: 1-800-237-4567 or 1-727-535-6339.
8. The protection modules in these SPDs may be replaceable, contact ASCO Surge Protection for replacement.

NOTICE - If the SPD model is configured to include a neutral connection ("Y", "H", "S", "N"), and a Neutral connection is not available, please contact factory.

## MODEL 520 - Suggested Circuit Breaker And Wire Size

Surge Rating Per Phase	Allowable Range				Factory Suggested Size	
	Circuit Breaker Size		Connection Wire Size		Circuit Breaker Size	Connection Wire Size
	With Disconnect	With Terminals	With Disconnect	With Terminals		
<b>130kA - 160kA</b>	15A - 150A	15A - 100A	#8 1/O	#14 - #2	40A	#8
<b>200kA - 300kA</b>	15A - 175A	15A - 100A	#8 1/O	#14 - #2	40A	#8
<b>400kA - 500kA</b>	15A - 175A	15A - 100A	#8 1/O	#14 - #2	100A	#2

## DIMENSIONAL INFORMATION

Surge Rating Per Phase	A x B x C	D	E	F	Weight
<b>130kA - 320kA</b>	16" x 14" x 8" [406 x 356 x 203]	16.75" [425.5]	12" [304.8]	0.31" [7.9]	130-160: 32 lb [14.5 kg] 200-320: 41 lb [18.6 kg]
<b>400kA-500kA</b>	20" x 16" x 8" [508 x 406 x 203]	21.25" [539.8]	20" [508]	0.44" [11.2]	56 lb. [25.4 kg]

### Summary Alarm Contacts

Connection shall be with #18 – 22 AWG. Form 'C' contacts are rated 5 amps at 250 VAC max.

(With AC Applied)  
 Pin 1 = Normally Open  
 Pin 2 = Common  
 Pin 3 = Normally Closed



Located on PCB behind the monitoring panel

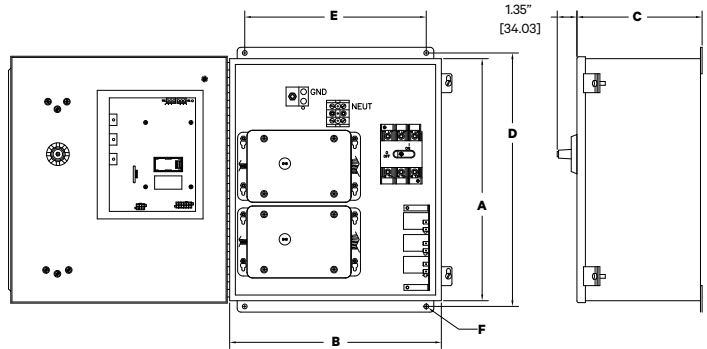

## MODEL 510 - Suggested Circuit Breaker And Wire Size

### Overcurrent Protection

#### (Circuit Breaker):

Allowable Range: 15A - 30A  
 Suggested Size: 30A

### Connection Wire:

Allowable Range: #14 - #10  
 Suggested Size: #10  
 #10 supplied when built with "W=Wire Leads" option.

### Weight:

6.5 lb. (3 kg)

### Summary Alarm Contacts:

Connection shall be with #18 – 22 AWG. Form 'C' contacts are rated 5 amps at 250 VAC max.

#### With AC Applied

NC = Normally Open  
 COM = Common  
 NO = Normally Closed

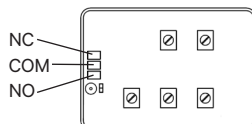

Shown with cover removed

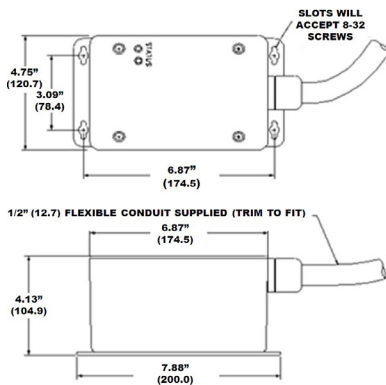

# MODEL 515 - Suggested Circuit Breaker And Wire Size

## Overcurrent Protection

### (Circuit Breaker):

Allowable Range: 15A - 100A  
Suggested Size: 30A

### Connection Wire:

Allowable Range: #14 - #2  
Suggested Size: #10

### Weight:

30 lb. (13.6 kg)

### Summary Alarm Contacts:

Connection shall be with #18 - 22 AWG. Form 'C' contacts are rated 5 amps at 250 VAC max.

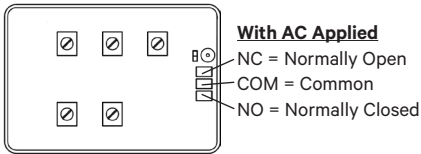

Shown with cover removed

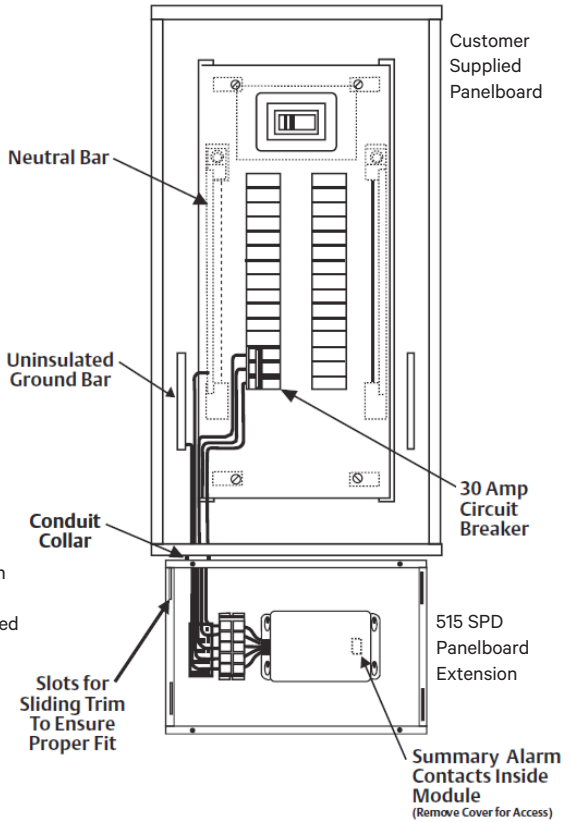

DIMENSIONAL INFORMATION	
A	18" [457]
B	12" [305]
C	6" [152]
D	11" [279]
E	15" [381]
F	20.25" [514]
G	21.5" [546]

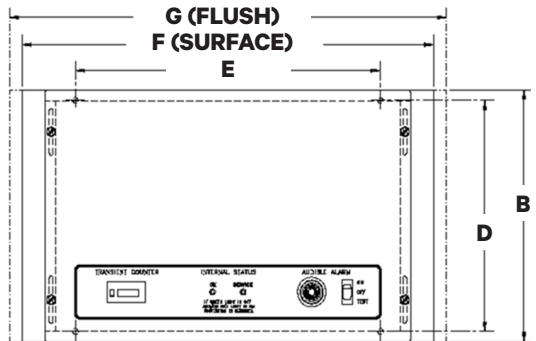
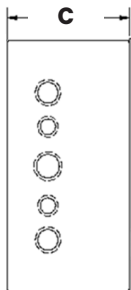
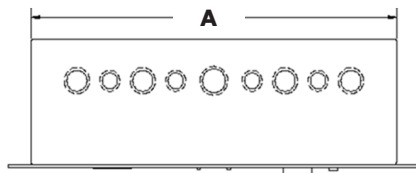

## MONITORING FEATURES

**External Status Indicators (Standard):** These indicators provide a summary of the status of the surge SPD module. For normal conditions, the green “OK” LED is illuminated and the red “Service” LED is extinguished. If the surge SPD module requires replacement, the green “OK” LED is turned off and the red “Service” LED illuminated.

**Audible Alarm (Standard/Optional):** If the surge SPD module requires replacement, an audible alarm may be activated to draw attention to the fact that repair service is required to restore the system to normal operation. An audible alarm disable is provided to silence the alarm. The system will automatically reset itself after repair. The audible alarm switch and “Service” LED can be tested by activating the “Test” switch on the system monitor panel.

**Summary Alarm Contact: (Standard/Optional)** One or two sets of summary alarm Form C relay contacts (N.O. and N.C.) are provided for remote indication of the failed surge SPD module. Contacts are rated 5 amps at 250 VAC maximum with a power factor of 1.0. Access to the contacts is provided via contact terminals located inside of the unit’s cover.

**Surge Counter (Optional, Model 520 & Model 515):** The surge counter is provided for transient voltage surge monitoring. The counter totalizes line surges monitored since the last time the counter was reset. The circuit counts all surges that deviate from the line sine wave. The factory setting is 30% over nominal line voltage. Other settings include 50%, 70%, and 100%.

## TROUBLESHOOTING/SERVICING MAINTENANCE

**Troubleshooting:** If status failure indication occurs or summary alarm contacts have changed state, a qualified electrician shall first determine if the systems voltage and proper phasing exists. If the SPD remains in an alarm condition once the electrician is satisfied that the electrical system and its connections are normal, the unit should be repaired. At this point consult the factory, having available the following information:

- Model number and serial number detailed on the units’ data label (located on the front of the enclosure).
- Nature of problem – (including condition of all status indicators and alarms).

**Servicing:** The ASCO 500 SERIES includes a ten year warranty. For servicing assistance, contact your local Sales Representative or ASCO Surge Protection at 1-800-237-4567 or 1-727-535-6339.

** DANGER** DANGER! ONLY QUALIFIED PERSONNEL SHOULD INSTALL OR SERVICE THIS SYSTEM. ELECTRICAL SAFETY PRE-CAUTIONS MUST BE FOLLOWED WHEN INSTALLING OR SERVICING THIS EQUIPMENT. TO PREVENT RISK OF ELECTRICAL SHOCK, TURN OFF AND LOCK OUT ALL POWER SOURCES TO THE UNIT BEFORE MAKING ELECTRICAL CONNECTIONS OR SERVICING.

**DANGER! SEULEMENT LE PERSONNEL QUALIFIÉ DOIT INSTALLER OU MAINTENIR CE SYSTÈME. DES PRÉCAUTIONS DE SÉCURITÉ EN ÉLECTRICITÉ DOIVENT ÊTRE SUIVIS LORS DE L’INSTALLATION OU DE LA MAINTENANCE DE CET EQUIPEMENT. POUR EVITER TOUT RISQUE DE CHOC ÉLECTRIQUE, DÉBRANCHEZ ET VEROUILLER TOUTES LES SOURCES D’ ALIMENTATION DE CET EQUIPEMENT AVANT DE LE BRANCHER OU LE MAINTENIR.**

**Corrective Maintenance:** The ASCO 500 SERIES SPDs are designed for years of trouble-free operation. However, even the most reliable equipment may fail under abnormal conditions. Diagnostic indicators are provided to indicate when the unit needs repair or replacement. To ensure continuity of surge protection, failed units should be repaired or replaced at the earliest convenient service opportunity. When replacing surge modules, other components should be inspected for damage and replaced if necessary. Standard electrical trouble-shooting procedures should be used to isolate problems other than failed surge current diverter modules. When replacing components, use identically rated components for continued proper operation and safety. Please contact factory for information on replacement parts.

**Preventative Maintenance (Inspection and Cleaning):** Periodic system inspections, cleaning, and connection checks are recommended to ensure reliable system performance and continued surge transient protection.

It is difficult to establish a schedule for preventative maintenance since conditions vary from site to site. Inspections for failed surge modules using available diagnostics should be done routinely (weekly or monthly).



# ASCO<sup>®</sup>

**14550 58th Street North  
Clearwater, Florida 33760**

**P (800) 237-4567**

**P (727) 535-6339**

**F (727) 539-8955**

**E [customer care@ascopower.com](mailto:customer care@ascopower.com)**

*While every precaution has been taken to ensure accuracy and completeness in this literature, ASCO assumes no responsibility, and disclaims all liability for damages resulting from use of this information or for any errors or omissions.*

**10-70103 Rev.J 08-18**