

**Instruction Manual
for AC Generators**

QAS 186 GdS USA

Instruction manual..... 3

Circuit diagrams 27

Warranty and Liability Limitation

Use only authorized parts.

Any damage or malfunction caused by the use of unauthorized parts is not covered by Warranty or Product Liability.

The manufacturer does not accept any liability for any damage arising for modifications, additions or conversions made without the manufacturer's approval in writing.

Copyright 2005, Atlas Copco Airpower n.v., Antwerp, Belgium.

Any unauthorized use or copying of the contents or any part thereof is prohibited.

This applies in particular to trademarks, model denominations, part numbers and drawings.

Congratulations on the purchase of your QAS 186 AC generator. It is a solid, safe and reliable machine, built according to the latest technology. Follow the instructions in this booklet and we guarantee you years of troublefree operation. Please read the following instructions carefully before starting to use your machine.

While every effort has been made to ensure that the information in this manual is correct, Atlas Copco does not assume responsibility for possible errors. Atlas Copco reserves the right to make changes without prior notice.

Contents

1. Safety precautions for portable generators4

2. Leading particulars8

2.1. General description8

2.2. Bodywork9

2.3. Markings.....9

2.4. Control and indicator panel9

2.5. Battery switch 11

2.6. Remote start (RS).....11

2.7. Output connections11

2.8. Dip-switches.....12

2.9. External fuel tank connection 12

2.10. Drain plugs and filler caps 12

2.11. Spillage free 12

2.12. Triple voltage with switch (3V).....13

2.13. Engine coolant heater 13

3. Operating instructions.....13

3.1. Installation.....13

3.2. Connecting the generator 14

3.3. Before starting 14

3.4. Starting.....15

3.5. During operation.....15

3.6. Stopping 15

4. Maintenance 16

4.1. Maintenance schedule16

4.2. Engine maintenance.....16

4.3. (*) Measuring the alternator insulation resistance 16

4.4. Engine oil specifications 17

4.5. Engine oil level check 17

4.6. Engine oil and oil filter change..... 17

4.7. Engine coolant specifications18

4.8. Coolant check.....18

5. Storage of the generator20

5.1. Storage20

5.2. Preparing for operation after storage20

6. Checks and trouble shooting.....20

6.1. Checking voltmeter P4.....20

6.2. Checking frequency meter P5.....20

6.3. Checking ammeters P1, P2 and P3.....20

6.4. Alternator trouble shooting21

6.5. Engine trouble shooting.....22

7. Technical specifications23

7.1. Readings on gauges23

7.2. Settings of switches.....23

7.3. Specifications of the engine/alternator/unit23

7.4. Conversion list of SI units into British units26

7.5. Dataplate26

CALIFORNIA
Proposition 65 Warning

Diesel engine exhaust and some of its constituents are known to the State of California to cause cancer, birth defects, and other reproductive harm.

1. Safety precautions for portable generators

To be read attentively and acted accordingly before towing, lifting, operating, performing maintenance or repairing the generator.

1.1 Introduction

The policy of Atlas Copco is to provide the users of their equipment with safe, reliable and efficient products. Factors taken into account are among others:

- the intended and predictable future use of the products, and the environments in which they are expected to operate,
- applicable rules, codes and regulations,
- the expected useful product life, assuming proper service and maintenance,
- providing the manual with up-to-date information.

Before handling any product, take time to read the relevant instruction manual. Besides giving detailed operating instructions, it also gives specific information about safety, preventive maintenance, etc.

Keep the manual always at the unit location, easy accessible to the operating personnel.

See also the safety precautions of the engine and possible other equipment, which are separately sent along or are mentioned on the equipment or parts of the unit.

These safety precautions are general and some statements will therefore not always apply to a particular unit.

Only people that have the right skills should be allowed to operate, adjust, perform maintenance or repair on Atlas Copco equipment. It is the responsibility of management to appoint operators with the appropriate training and skill for each category of job.

Skill level 1: Operator

An operator is trained in all aspects of operating the unit with the push-buttons, and is trained to know the safety aspects.

Skill level 2: Mechanical technician

A mechanical technician is trained to operate the unit the same as the operator. In addition, the mechanical technician is also trained to perform maintenance and repair, as described in the instruction manual, and is allowed to change settings of the control and safety system. A mechanical technician does not work on live electrical components.

Skill level 3: Electrical technician

An electrical technician is trained and has the same qualifications as both the operator and the mechanical technician. In addition, the electrical technician may carry out electrical repairs within the various enclosures of the unit. This includes work on live electrical components.

Skill level 4: Specialist from the manufacturer

This is a skilled specialist sent by the manufacturer or its agent to perform complex repairs or modifications to the equipment.

In general it is recommended that not more than two people operate the unit, more operators could lead to unsafe operating conditions. Take necessary steps to keep unauthorized persons away from the unit and eliminate all possible sources of danger at the unit.

When handling, operating, overhauling and/or performing maintenance or repair on Atlas Copco equipment, the mechanics are expected to use safe engineering practices and to observe all relevant local safety requirements and ordinances. The following list is a reminder of special safety directives and precautions mainly applicable to Atlas Copco equipment.

Neglecting the safety precautions may endanger people as well as environment and machinery:

- endanger people due to electrical, mechanical or chemical influences,
- endanger the environment due to leakage of oil, solvents or other substances,
- endanger the machinery due to function failures.

All responsibility for any damage or injury resulting from neglecting these precautions or by non-observance of ordinary caution and due care required in handling, operating, maintenance or repair, also if not expressly mentioned in this instruction manual, is disclaimed by Atlas Copco.

The manufacturer does not accept any liability for any damage arising from the use of non-original parts and for modifications, additions or conversions made without the manufacturer's approval in writing.

If any statement in this manual does not comply with local legislation, the stricter of the two shall be applied.

Statements in these safety precautions should not be interpreted as suggestions, recommendations or inducements that it should be used in violation of any applicable laws or regulations.

1.2 General safety precautions

- 1 The owner is responsible for maintaining the unit in a safe operating condition. Unit parts and accessories must be replaced if missing or unsuitable for safe operation.
- 2 The supervisor, or the responsible person, shall at all times make sure that all instructions regarding machinery and equipment operation and maintenance are strictly followed and that the machines with all accessories and safety devices, as well as the consuming devices, are in good repair, free of abnormal wear or abuse, and are not tampered with.
- 3 Whenever there is an indication or any suspicion that an internal part of a machine is overheated, the machine shall be stopped but no inspection covers shall be opened before sufficient cooling time has elapsed; this to avoid the risk of spontaneous ignition of oil vapor when air is admitted.
- 4 Normal ratings (pressures, temperatures, speeds, etc.) shall be durably marked.
- 5 Operate the unit only for the intended purpose and within its rated limits (pressure, temperature, speeds, etc.).
- 6 The machinery and equipment shall be kept clean, i.e. as free as possible from oil, dust or other deposits.
- 7 To prevent an increase in working temperature, inspect and clean heat transfer surfaces (cooler fins, intercoolers, fluid jackets, etc.) regularly. See the maintenance schedule.
- 8 All regulating and safety devices shall be maintained with due care to ensure that they function properly. They may not be put out of action.
- 9 Pressure and temperature gauges shall be checked regularly with regard to their accuracy. They shall be replaced whenever outside acceptable tolerances.
- 10 Safety devices shall be tested as described in the maintenance schedule of the instruction manual to determine that they are in good operating condition.
- 11 Mind the markings and information labels on the unit.
- 12 In the event the safety labels are damaged or destroyed, they must be replaced to ensure operator safety.
- 13 Keep the work area neat. Lack of order will increase the risk of accidents.
- 14 When working on the unit, wear safety clothing. Depending on the kind of activities these are: safety glasses, ear protection, safety helmet (including visor), safety gloves, protective clothing, safety shoes. Do not wear the hair long and loose (protect long hair with a hairnet), or wear loose clothing or jewelry.
- 15 Take precautions against fire. Handle fuel, oil and anti-freeze with care because they are inflammable substances. Do not smoke or approach with naked flame when handling such substances. Keep a fire-extinguisher in the vicinity.
- 16a **Portable generators (with earthing pin):**
Earth the generator as well as the load properly.
- 16b **Portable generators IT:**
Note: This generator is built to supply a sheer alternating current IT network.
Earth the load properly.

1.3 Safety during transport and installation

To lift a unit, all loose or pivoting parts, e.g. doors and towbar, shall first be securely fastened.

Do not attach cables, chains or ropes directly to the lifting eye; apply a crane hook or lifting shackle meeting local safety regulations. Never allow sharp bends in lifting cables, chains or ropes.

Helicopter lifting is not allowed.

It is strictly forbidden to dwell or stay in the risk zone under a lifted load. Never lift the unit over people or residential areas. Lifting acceleration and retardation shall be kept within safe limits.

- 1 Before towing the unit:
 - check the towbar, the brake system and the towing eye. Also check the coupling of the towing vehicle,
 - check the towing and brake capability of the towing vehicle,
 - check that the towbar, jockey wheel or stand leg is safely locked in the raised position,
 - ascertain that the towing eye can swivel freely on the hook,
 - check that the wheels are secure and that the tires are in good condition and inflated correctly,
 - connect the signalisation cable, check all lights and connect the pneumatic brake couplers,
 - attach the safety break-away cable or safety chain to the towing vehicle,
 - remove wheel chocks, if applied, and disengage the parking brake.
- 2 To tow a unit use a towing vehicle of ample capacity. Refer to the documentation of the towing vehicle.
- 3 If the unit is to be backed up by the towing vehicle, disengage the overrun brake mechanism (if it is not an automatic mechanism).
- 4 Never exceed the maximum towing speed of the unit (mind the local regulations).
- 5 Place the unit on level ground and apply the parking brake before disconnecting the unit from the towing vehicle. Unclip the safety break-away cable or safety chain. If the unit has no parking brake or jockey wheel, immobilize the unit by placing chocks in front of and/or behind the wheels. When the towbar can be positioned vertically, the locking device must be applied and kept in good order.
- 6 To lift heavy parts, a hoist of ample capacity, tested and approved according to local safety regulations, shall be used.
- 7 Lifting hooks, eyes, shackles, etc., shall never be bent and shall only have stress in line with their design load axis. The capacity of a lifting device diminishes when the lifting force is applied at an angle to its load axis.
- 8 For maximum safety and efficiency of the lifting apparatus all lifting members shall be applied as near to perpendicular as possible. If required, a lifting beam shall be applied between hoist and load.
- 9 Never leave a load hanging on a hoist.
- 10 A hoist has to be installed in such a way that the object will be lifted perpendicular. If that is not possible, the necessary precautions must be taken to prevent load-swinging, e.g. by using two hoists, each at approximately the same angle not exceeding 30° from the vertical.
- 11 Locate the unit away from walls. Take all precautions to ensure that hot air exhausted from the engine and driven machine cooling systems cannot be recirculated. If such hot air is taken in by the engine or driven machine cooling fan, this may cause overheating of the unit; if taken in for combustion, the engine power will be reduced.
- 12 Generators shall be stalled on an even, solid floor, in a clean location with sufficient ventilation. If the floor is not level or can vary in inclination, consult Atlas Copco.
- 13 The electrical connections shall correspond to local codes. The machines shall be earthed and protected against short circuits by fuses or circuit breakers.
- 14 Never connect the generator outlets to an installation which is also connected to a public mains.
- 15 Before connecting a load, switch off the corresponding circuit breaker, and check whether frequency, voltage, current and power factor comply with the ratings of the generator.

1.4 Safety during use and operation

- 1 When the unit has to operate in a fire-hazardous environment, each engine exhaust has to be provided with a spark arrestor to trap incendiary sparks.
- 2 The exhaust contains carbon monoxide which is a lethal gas. When the unit is used in a confined space, conduct the engine exhaust to the outside atmosphere by a pipe of sufficient diameter; do this in such a way that no extra back pressure is created for the engine. If necessary, install an extractor. Observe any existing local regulations. Make sure that the unit has sufficient air intake for operation. If necessary, install extra air intake ducts.
- 3 When operating in a dust-laden atmosphere, place the unit so that dust is not carried towards it by the wind. Operation in clean surroundings considerably extends the intervals for cleaning the air intake filters and the cores of the coolers.
- 4 Never remove a filler cap of the coolant system of a hot engine. Wait until the engine has sufficiently cooled down.
- 5 Never refill fuel while the unit is running, unless otherwise stated in the Atlas Copco Instruction Book (AIB). Keep fuel away from hot parts such as air outlet pipes or the engine exhaust. Do not smoke when fuelling. When fuelling from an automatic pump, an earthing cable should be connected to the unit to discharge static electricity. Never spill nor leave oil, fuel, coolant or cleansing agent in or around the unit.
- 6 All doors shall be shut during operation so as not to disturb the cooling air flow inside the bodywork and/or render the silencing less effective. A door should be kept open for a short period only e.g. for inspection or adjustment.
- 7 Periodically carry out maintenance works according to the maintenance schedule.
- 8 Stationary housing guards are provided on all rotating or reciprocating parts not otherwise protected and which may be hazardous to personnel. Machinery shall never be put into operation, when such guards have been removed, before the guards are securely reinstalled.
- 9 Noise, even at reasonable levels, can cause irritation and disturbance which, over a long period of time, may cause severe injuries to the nervous system of human beings.
When the sound pressure level, at any point where personnel normally has to attend, is:
 - below 70 dB(A): no action needs to be taken,
 - above 70 dB(A): noise-protective devices should be provided for people continuously being present in the room,
 - below 85 dB(A): no action needs to be taken for occasional visitors staying a limited time only,
 - above 85 dB(A): room to be classified as a noise-hazardous area and an obvious warning shall be placed permanently at each entrance to alert people entering the room, for even relatively short times, about the need to wear ear protectors,
 - above 95 dB(A): the warning(s) at the entrance(s) shall be completed with the recommendation that also occasional visitors shall wear ear protectors,
 - above 105 dB(A): special ear protectors that are adequate for this noise level and the spectral composition of the noise shall be provided and a special warning to that effect shall be placed at each entrance.
- 10 Insulation or safety guards of parts the temperature of which can be in excess of 80°C (175°F) and which may be accidentally touched by personnel shall not be removed before the parts have cooled to room temperature.
- 11 Never operate the unit in surroundings where there is a possibility of taking in flammable or toxic fumes.
- 12 If the working process produces fumes, dust or vibration hazards, etc., take the necessary steps to eliminate the risk of personnel injury.
- 13 When using compressed air or inert gas to clean down equipment, do so with caution and use the appropriate protection, at least safety glasses, for the operator as well as for any bystander. Do not apply compressed air or inert gas to your skin or direct an air or gas stream at people. Never use it to clean dirt from your clothes.
- 14 When washing parts in or with a cleaning solvent, provide the required ventilation and use appropriate protection such as a breathing filter, safety glasses, rubber apron and gloves, etc.

- 15 Safety shoes should be compulsory in any workshop and if there is a risk, however small, of falling objects, wearing of a safety helmet should be included.
- 16 If there is a risk of inhaling hazardous gases, fumes or dust, the respiratory organs must be protected and depending on the nature of the hazard, so must the eyes and skin.
- 17 Remember that where there is visible dust, the finer, invisible particles will almost certainly be present too; but the fact that no dust can be seen is not a reliable indication that dangerous, invisible dust is not present in the air.
- 18 Never operate the generator in excess of its limits as indicated in the technical specifications and avoid long no-load sequences.
- 19 Never operate the generator in a humid atmosphere. Excessive moisture causes worsening of the generator insulation.
- 20 Do not open electrical cabinets, cubicles or other equipment while voltage is supplied. If such cannot be avoided, e.g. for measurements, tests or adjustments, have the action carried out by a qualified electrician only, with appropriate tools, and ascertain that the required bodily protection against electrical hazards is applied.
- 21 Never touch the power terminals during operation of the machine.
- 22 Whenever an abnormal condition arises, e.g. excessive vibration, noise, odor, etc., switch the circuit breakers to OFF and stop the engine. Correct the faulty condition before restarting.
- 23 Check the electric cables regularly. Damaged cables and insufficient tightening of connections may cause electric shocks. Whenever damaged wires or dangerous conditions are observed, switch the circuit breakers to OFF and stop the engine. Replace the damaged wires or correct the dangerous condition before restarting. Make sure that all electric connections are securely tightened.
- 24 Avoid overloading the generator. The generator is provided with circuit breakers for overload protection. When a breaker has tripped, reduce the concerned load before restarting.
- 25 If the generator is used as stand-by for the mains supply, it must not be operated without control system which automatically disconnects the generator from the mains when the mains supply is restored.
- 26 Never remove the cover of the output terminals during operation. Before connecting or disconnecting wires, switch off the load and the circuit breakers, stop the machine and make sure that the machine cannot be started inadvertently or there is any residual voltage on the power circuit.
- 27 Running the generator at low load for long periods will reduce the lifetime of the engine.

1.5 Safety during maintenance and repair

Maintenance, overhaul and repair work shall only be carried out by adequately trained personnel; if required, under supervision of someone qualified for the job.

- 1 Use only the correct tools for maintenance and repair work, and only tools which are in good condition.
- 2 Parts shall only be replaced by genuine Atlas Copco replacement parts.
- 3 All maintenance work, other than routine attention, shall only be undertaken when the unit is stopped. Steps shall be taken to prevent inadvertent starting. In addition, a warning sign bearing a legend such as "work in progress; do not start" shall be attached to the starting equipment. On engine-driven units the battery shall be disconnected and removed or the terminals covered by insulating caps. On electrically driven units the main switch shall be locked in open position and the fuses shall be taken out. A warning sign bearing a legend such as "work in progress; do not supply voltage" shall be attached to the fuse box or main switch.
- 4 Prior to stripping an engine or other machine or undertaking major overhaul on it, prevent all movable parts from rolling over or moving.
- 5 Make sure that no tools, loose parts or rags are left in or on the machine. Never leave rags or loose clothing near the engine air intake.
- 6 Never use flammable solvents for cleaning (fire-risk).
- 7 Take safety precautions against toxic vapors of cleaning liquids.
- 8 Never use machine parts as a climbing aid.
- 9 Observe scrupulous cleanliness during maintenance and repair. Keep away dirt, cover the parts and exposed openings with a clean cloth, paper or tape.
- 10 Never weld on or perform any operation involving heat near the fuel or oil systems. Fuel and oil tanks must be completely purged, e.g. by steam-cleaning, before carrying out such operations. Never weld on, or in any way modify, pressure vessels. Disconnect the alternator cables during arc welding on the unit.
- 11 Support the towbar and the axle(s) securely if working underneath the unit or when removing a wheel. Do not rely on jacks.
- 12 Do not remove any of, or tamper with, the sound-damping material. Keep the material free of dirt and liquids such as fuel, oil and cleansing agents. If any sound-damping material is damaged, replace it to prevent the sound pressure level from increasing.
- 13 Use only lubricating oils and greases recommended or approved by Atlas Copco or the machine manufacturer. Ascertain that the selected lubricants comply with all applicable safety regulations, especially with regard to explosion or fire-risk and the possibility of decomposition or generation of hazardous gases. Never mix synthetic with mineral oil.
- 14 Protect the engine, alternator, air intake filter, electrical and regulating components, etc., to prevent moisture ingress, e.g. when steam-cleaning.
- 15 When performing any operation involving heat, flames or sparks on a machine, the surrounding components shall first be screened with non-flammable material.
- 16 Never use a light source with open flame for inspecting the interior of a machine.
- 17 When repair has been completed, the machine shall be barred over at least one revolution for reciprocating machines, several revolutions for rotary ones to ensure that there is no mechanical interference within the machine or driver. Check the direction of rotation of electric motors when starting up the machine initially and after any alteration to the electrical connection(s) or switch gear, to check that the oil pump and the fan function properly.
- 18 Maintenance and repair work should be recorded in an operator's logbook for all machinery. Frequency and nature of repairs can reveal unsafe conditions.
- 19 When hot parts have to be handled, e.g. shrink fitting, special heat-resistant gloves shall be used and, if required, other body protection shall be applied.
- 20 When using cartridge type breathing filter equipment, ascertain that the correct type of cartridge is used and that its useful service life is not surpassed.
- 21 Make sure that oil, solvents and other substances likely to pollute the environment are properly disposed of.

- 22 Before clearing the generator for use after maintenance or overhaul, submit it to a testrun, check that the AC power performance is correct and that the control and shut down devices function correctly.

1.6 Tool applications safety

Apply the proper tool for each job. With the knowledge of correct tool use and knowing the limitations of tools, along with some common sense, many accidents can be prevented.

Special service tools are available for specific jobs and should be used when recommended. The use of these tools will save time and prevent damage to parts.

1.7 Battery safety precautions

Batteries

When servicing batteries, always wear protecting clothing and glasses.

- 1 The electrolyte in batteries is a sulphuric acid solution which is fatal if it hits your eyes, and which can cause burns if it contacts your skin. Therefore, be careful when handling batteries, e.g. when checking the charge condition.
- 2 Install a sign prohibiting fire, open flame and smoking at the post where batteries are being charged.
- 3 When batteries are being charged, an explosive gas mixture forms in the cells and might escape through the vent holes in the plugs. Thus an explosive atmosphere may form around the battery if ventilation is poor, and can remain in and around the battery for several hours after it has been charged. Therefore:
 - never smoke near batteries being, or having recently been, charged,
 - never break live circuits at battery terminals, because a spark usually occurs.
- 4 When connecting an auxiliary battery (AB) in parallel to the unit battery (CB) with booster cables: connect the + pole of AB to the + pole of CB, then connect the - pole of CB to the mass of the unit. Disconnect in the reverse order.

2. Leading particulars

2.1 General description

The QAS 186 is an AC generator, built for continuous running at sites where no electricity is available.

The QAS 186 generator is driven by a water-cooled diesel engine, manufactured by DETROIT DIESEL.

The generator can run in 3 different modes:

1 phase	60 Hz	240 V	157.97 hp / 117.8 kW
3 phase - lower voltage	60 Hz	208 V	193.10 hp / 144 kW
3 phase - higher voltage	60 Hz	480 V	193.10 hp / 144 kW

An overview of the main parts is given in the diagram below.

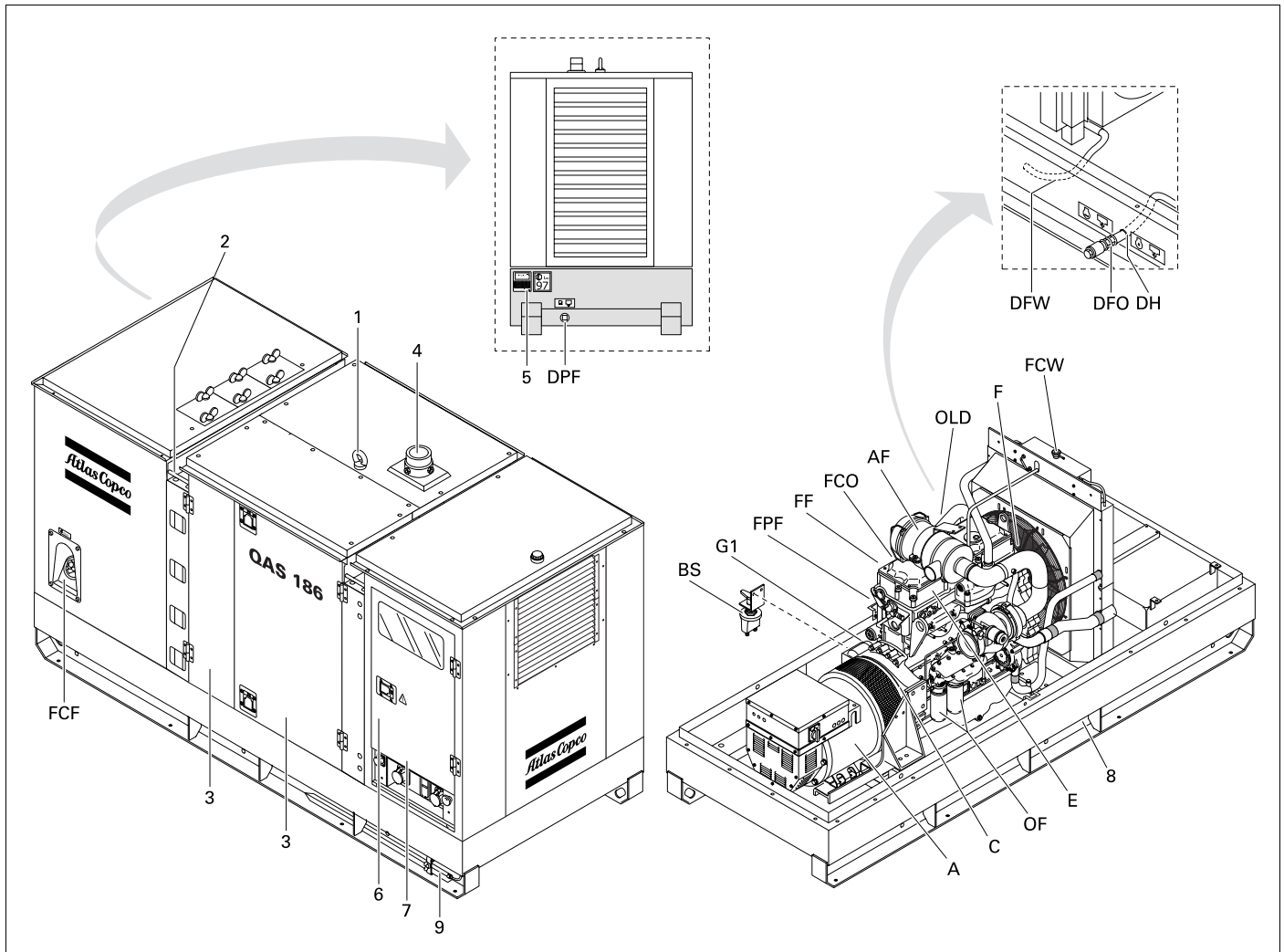

1	Lifting eye	A	Alternator	F	Fan
2	Guiding rod	AF	Air filter	FCF	Filler cap fuel
3	Side doors, access to engine and alternator	BS	Battery switch	FCO	Filler cap engine oil
4	Engine exhaust	C	Coupling	FCW	Filter cap coolant
5	Data Plate	DFO	Drain flexible engine oil	FF	Fuel filter
6	Side door, access to control and indicator panel	DFW	Drain flexible coolant	FPF	Fuel pre-filter
7	Output terminal board	DH	Drain and access hole (in the frame)	G1	Battery
8	Hole for forklift	DPF	Drain plug fuel	OF	Oil filter
9	Grounding rod	E	Engine	OLD	Engine oil level dipstick

2.2 Bodywork

The alternator, the engine, the cooling system, etc. are enclosed in a sound-insulated bodywork that can be opened by means of side doors (and service plates).

The generator's lifting eye is located in the middle of the roof. The recesses in the roof have guiding rods at both sides.



Never use the guiding rods to lift the generator.

To be able to lift the QAS 186 by means of a forklift, rectangular holes are provided in the frame.

2.3 Markings

A brief description of all markings provided on the QAS 186 is given hereafter.



Indicates that an electric voltage, dangerous to life, is present. Never touch the electric terminals during operation.



Indicates that the engine exhaust is a hot and harmful gas, which is toxic in case of inhalation. Always make sure that the unit is operated outside or in a well-ventilated room.



Indicates that these parts can become very hot during operation (e.g. engine, cooler, etc.). Always make sure that these parts are cooled down before touching them.



Indicates that the generator may be refuelled with diesel fuel only.



Indicates the drain for the engine oil.



Indicates the drain for the coolant.



Indicates the drain plug for the engine fuel.



Indicates that the guiding rods may not be used to lift the generator. Always use the lifting eye in the roof of the generator to lift it.



Indicates the lifting eye of the generator.



Indicates that the alternator should not be cleaned with high pressurised water.



Indicates that the unit may start automatically and that the instruction book has to be consulted prior to use.



Indicates the 3-way valve.

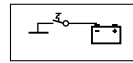

Indicates the battery switch.

Part No.	QAS 186 G4 - QAS 246 G4	QAS 306 G4 - QAS 356 G4
STARTER PACK		
101	2012 001 00	
102	2012 002 00	
103	2012 003 00	
104	2012 004 00	
105	2012 005 00	
106	2012 006 00	
107	2012 007 00	
PAINT - Empty Cds		
108	2012 008 00	
109	2012 009 00	
110	2012 010 00	

Indicates the partnumbers of the different service packs and of the engine oil. These parts can be ordered to the factory.

2.4 Control and indicator panel

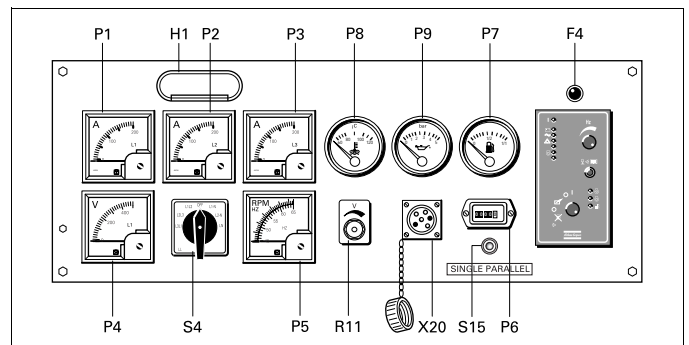

The control and indicator panel is located behind a door in the side panel. The hinged door is partly transparent and allows easy access to the parts mounted behind it. Panel light H1 lights up as soon as the starter switch is turned into position I or the remote start/stop switch is put in position start, indicating that the fuel solenoid is energized.

2.4.1 Engine gauges

P6Hourmeter

P7Fuel level gauge

P8Engine coolant temperature gauge

P9Engine oil pressure gauge

2.4.2 Generator gauges

P1Ammeter line L1

Indicates the outgoing current in the first line (L1).

P2Ammeter line L2

Indicates the outgoing current in the second line (L2).

P3Ammeter line L3

Indicates the outgoing current in the third line (L3).

P4Voltmeter

Indicates the voltage selected by means of voltage selector switch S4.

P5Frequency / RPM meter

Indicates the frequency of the supply voltage and the speed of the engine.

S4..... Voltmeter selector switch

Allows to measure the voltage between each of the phases and between each phase and the neutral. It also allows to switch off the voltmeter.

2.4.3 Separate diagnostic socket

X20.... Diagnostic data socket

Allows to connect the diagnostic data reader. Refer to chapter “Engine trouble shooting” - “Engine diagnostic codes” .

2.4.4 Paralleling

S15.... Single/parallel switch

Enables the generator (combined with the SAPE unit) to operate in parallel mode. For more information about paralleling, please consult the SAPE unit instruction manual (Printed matter number 2950 2002 00 or higher).

2.4.5 Engine controls and lamps

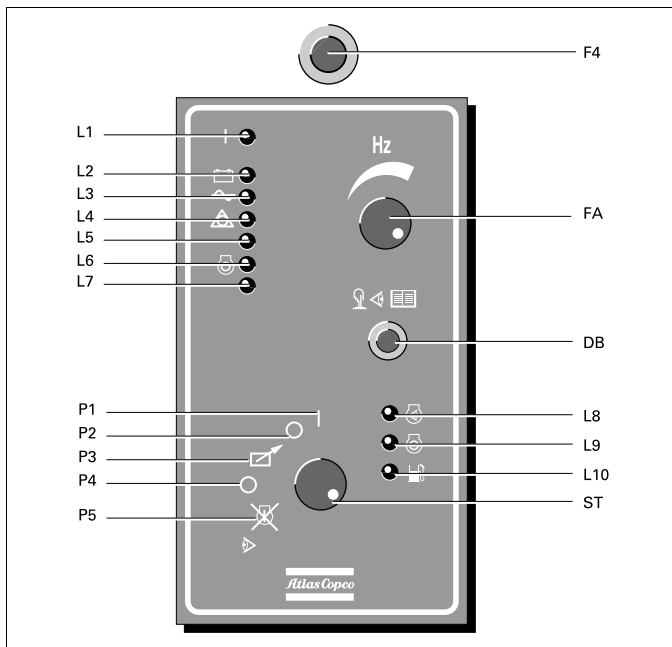

L1..... Electrical system indicator

Lights up when the electrical system of the engine is energized.

L2..... Alternator charging indicator

Goes out after starting, indicating that the alternator is charging. A failing alternator however will not shut the engine down.

L3..... AC shut down indicator

Lights up when no AC input (< 70% of the voltage nominal) is present.

L4..... Emergency stop LED

L5..... Spare shut down indicator

Can be used to wire an extra shut down.

L6 Engine shutdown

Lights up when a major fault occurred which shuts down the engine.

L7 Spare shut down indicator

Can be used to wire an extra shut down.

L8 Check engine light

With the starter switch into the P1/P5 position and the engine running, push and hold the diagnostic request switch to have the inactive codes flashing on the check engine light.

L9 Stop engine light

With the starter switch into the P1/P5 position and the engine running, push and hold the diagnostic request switch to have the active codes flashing on the stop engine light.

L10 Fuel level indicator

Lights up when the fuel level is below 20 % of the maximum fuel tank capacity.

ST..... Starter switch

P1 Position P1

Used to select normal start and to disable remote start. If the unit fails to start the first time, two more starting attempts will take place with 12 seconds waiting time in between.

P2-4... Position P2-4

Used to switch off the power supply from the battery or to reset after a shutdown due to a failure. The unit will not be able to start up.

P3 Position P3

Used to select remote start.

P5 Position P5

The generator will not start. When the starter switch is in this position, the engine faults can be read out by the diagnostic request button (DB).



After approximately 20 seconds in position I without starting, the control system will automatically shut down (battery saving purpose) indicating a low oil pressure failure. In this case, a reset of the control system by putting the switch in position O is necessary.

DBDiagnostic request switch

With the ignition switch on and the engine at idle or not running, push and hold the switch to have the active codes flashing on the stop engine light (L9), followed by the inactive codes flashing on the check engine light (L8). For detailed information concerning the engine diagnostic codes, see chapter “Engine trouble shooting” - “Engine diagnostic codes”.

F4Fuse

The fuse activates when the current from the battery to the engine control circuit exceeds its setting. The fuse can be switched on and off by pushing the button.

FA.....Frequency adjust potentiometer

Allows to adjust the frequency of the output voltage. This adjustment has no influence on the output voltage.



Changing the output frequency is only allowed after disconnecting the load.

R11.... Output voltage adjust potentiometer

Allows to adjust the output voltage. R11 is located on the control and indicator panel.

2.5 Battery switch

The battery switch is situated inside the sound-insulated bodywork. It allows to open or to close the electrical connection between the battery and the engine circuits.



Never turn the battery switch off while the engine is running

2.6 Remote start (RS)

"Remote start" allows to switch the unit on or off without using the control panel located on the unit. The start module of the control panel provides extra connections for the remote start/stop switch and the plant contactor (voltage free contact), both to be installed by the customer.



The plant contactor should be sized according to the load. The maximum current through the voltage free contact is 3 A.

The remote start/stop switch Sx has to meet the following specifications: 24 V DC, 4 A.

Refer to the circuit diagram for the correct connection of the plant contactor and the remote start/stop switch.

A shunt trip coil will switch off Q1.1 or Q1.2 (depending on the mode the generator is running in) in case of an emergency stop or an earth fault.

2.7 Output connections

The output connections are situated below the control and indicator panel.

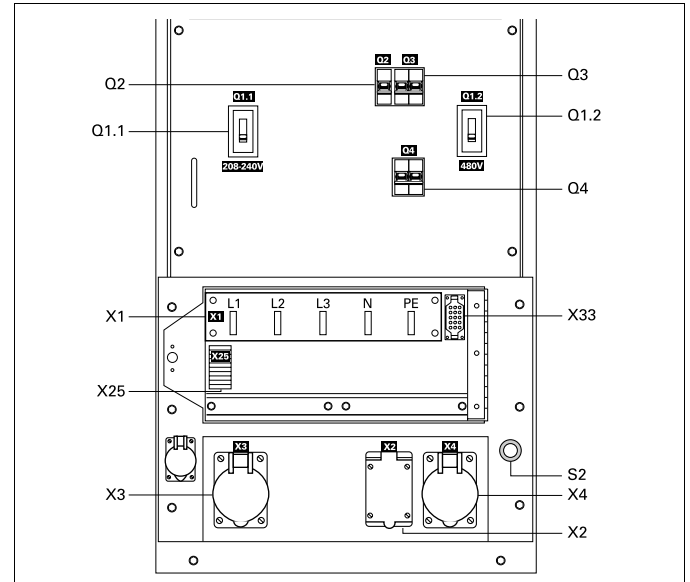

S2.....Emergency stop button

Push the button to stop the generator in case of an emergency. When the button is pressed, it must be unlocked, by turning it anti-clockwise, before the generator can be restarted.

Q1.1...Circuit breaker for low voltage

Interrupts the low voltage power supply towards X1 when a short-circuit occurs at the load side, or when the overcurrent protection (500 A) is activated. It must be reset manually after eliminating the problem.

Q1.2...Circuit breaker for high voltage

Interrupts the high voltage power supply towards X1 when a short-circuit occurs at the load side, or when the overcurrent protection (215 A) is activated. It must be reset manually after eliminating the problem.

Q2.....Circuit breaker

Interrupts phase L2 towards X2 when a short-circuit occurs at the load side, or when the overcurrent protection (20 A) is activated. It must be reset manually after eliminating the problem.

Q3.....Circuit breaker

Interrupts line L1 and L2 towards X3 when a short-circuit occurs at the load side, or when the overcurrent protection (50 A) is activated. It must be reset manually after eliminating the problem.

Q4.....Circuit breaker

Interrupts line L1 and L2 towards X4 when a short-circuit occurs at the load side, or when the overcurrent protection (50 A) is activated. It must be reset manually after eliminating the problem.

X1..... Main power supply - Terminal board

Terminals L1, L2, L3, N (= neutral) and PE (= grounding), hidden behind the control panel door and behind a small transparent door.

X2..... Single phase outlet socket

Provides lines L2, N (= neutral), and PE (= grounding).

X3..... Single phase outlet socket

Provides lines L1, L2, N (= neutral), and PE (= grounding).

X4..... Single phase outlet socket

Provides lines L1, L2, N (= neutral), and PE (= grounding).

X25.... Connection block

Allows easy connection for a remote start switch.



Refer to the circuit diagrams for the correct connection.

X33.... Connector X33

Connector for communication between the generator and the SAPE unit. For details refer to the SAPE unit instruction manual.

2.8 Dip-switches

For correct functioning of the module, the DIP switches at the back of the control module should be positioned as follows:

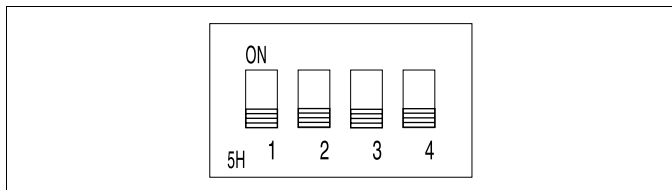

- S4: ON: Short start delay
- S4: Off: Long Start delay

2.9 External fueltank connection

The "External fueltank connection" allows to bypass the internal fueltank and to connect an external fueltank to the unit.

When using an external fueltank, make sure to connect the fuel supply line as well as the fuel return line. Connections to fuellines ought to be air-tight to prevent air from entering the fuel system.

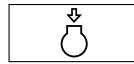

Indicates the fuel supply line from the tank to the engine.

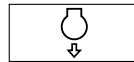

Indicates the fuel return line from the engine to the tank.



Indicates the internal fueltank.



Indicates the external fueltank.

2.10 Drain plugs and filler caps

The drain holes for the engine oil, the coolant and the plug for the fuel, are located and labelled on the frame; the fuel drain plug at the front, the others at the service side.

The drain flexible for engine oil can be brought to the outside of the generator through the drain hole.



The drain hole can also be used to guide external fuel tank connections. When connecting an external fueltank, use the 3-way valves. Refer to "External fueltank connection".

The filler cap for the engine coolant is accessible via an opening in the roof. The fuel filler cap is located in the side panel.

2.11 Spillage free

A Spillage free skid with forklift slots allows the customer to transport the generator easily with a forklift.

It avoids accidental spilling of engine fluids.

2.12 Triple voltage with switch (3V)

The generator can run in three different modes:

- 1 phase
- 3 phase, lower voltage
- 3 phase, higher voltage

Depending on which mode the generator is running in, circuit breaker Q1.1 or Q1.2 will be operational.

Circuit breakers Q1.1 and Q1.2 cannot be switched on at the same time. This is prevented by means of the auxiliary voltage selection relays K11 and K12 (refer to the circuit diagram).

The selection between the three modes is done by means of S10.

S10.... Output voltage selector switch

Allows to select a 3 phase high output voltage, a 3 phase low output voltage or a 1 phase low output voltage. Selector switch S10 is located on the alternator.



Changing the output voltage is only allowed after shutdown.

After changing the output voltage by means of the selection switch S10, adjust the output voltage by means of potentiometer R11 to the required value.

1 phase

When using this selection, the generator provides a 240 V output voltage.

3 phase lower voltage

When using this selection, the generator provides a 208 V output voltage.

3 phase higher voltage

When using this selection, the generator provides a 480 V output voltage.

2.13 Engine coolant heater

To make sure that the engine can start and accept load immediately, an external cooling water heater (2 x 1000 W, 240 V) is provided which keeps the engine temperature between 38°C (100.4°F) and 49°C (120.2°F).



The engine coolant heater is always included with AMF.

3. Operating instructions



In your own interest, always strictly observe all relevant safety instructions.

Do not operate the generator in excess of the limitations mentioned in the Technical Specifications.

Local rules concerning the setting up of low voltage power installations (below 1.000 V) must be respected when connecting site distribution panels, switch gear or loads to the generator.

At each start-up and at any time a new load is connected, the earthing of the generator must be verified. Earthing must be done either by the earthing rod or, if available, by an existing, suitable earthing installation. The protective system against excessive contact voltage is not effective unless a suitable earthing is made.

The generator is wired for a TN-system to IEC 364-3, i.e. one point in the power source directly earthed - in this case the neutral. The exposed conductive parts of the electric installation must be directly connected to the functional earth.

If operating the generator in another power system, e.g. an IT-system, other protective devices required for these types must be installed. In any case only a qualified electrician is authorized to remove the connection between the neutral (N) and earth terminals in the terminal box of the alternator.

3.1 Installation

- Place the generator on a horizontal, even and solid floor.
- Check that the engine exhaust is not directed towards people. If the generator is operated indoors, install an exhaust pipe of sufficient diameter to duct the engine exhaust towards the outside. Check for sufficient ventilation so that the cooling air is not recirculated. If necessary, consult Atlas Copco.
- Leave enough space for operation, inspection and maintenance (at least 1 meter at each side).
- Check that the inner earthing system is in compliance with the local legislation.
- Use coolant for the engine cooling system. Refer to the Engine instruction book for the proper coolant mixture.
- Check the tightness of the bolts and nuts.

3.2 Connecting the generator

3.2.1 Precautions for non-linear and sensitive loads



Non-linear loads draw currents with high contents in harmonics, causing distortion in the wave form of the voltage generated by the alternator.

The most common non-linear, 3-phase loads are thyristor/rectifier-controlled loads, such as convertors supplying voltage to variable speed motors, uninterruptable power supplies and Telecom supplies. Gas-discharge lighting arranged in single-phase circuits generate high 3rd harmonics and risk for excessive neutral current.

Loads most sensitive to voltage distortion include incandescent lamps, discharge lamps, computers, X-ray equipment, audio amplifiers and elevators.

Consult Atlas Copco for measures against the adverse influence of non-linear loads.

3.2.2 Quality, minimum section and maximum length of cables

The cable connected to the terminal board of the generator must be selected in accordance with local legislation. The type of cable, its rated voltage and current carrying capacity are determined by installation conditions, stress and ambient temperature. For flexible wiring, rubber-sheathed, flexible core conductors must be used.

3.2.3 Connecting the load

Site distribution panel

If outlet sockets are required, they must be mounted on a site distribution panel supplied from the terminal board of the generator and in compliance with local regulations for power installations on building sites.

Protection



For safety reasons, it is necessary to provide an isolating switch or circuit breaker in each load circuit. Local legislation may impose the use of isolating devices which can be locked.

- Check whether frequency, voltage and current comply with the ratings of the generator.
- Provide for the load cable, without excessive length, and lay it out in a safe way without forming coils.
- Open the door of the control and indicator panel and the transparent door in front of the terminal board X1.
- Provide the wire ends with cable lugs suited for the cable terminals.
- Loosen the cable clamp and push the wire ends of the load cable through the orifice and clamp.
- Connect the wires to the proper terminals (L1, L2, L3, N and PE) of X1 and tighten the bolts securely.
- Tighten the cable clamp.
- Close the transparent door in front of X1.

3.3 Before starting

- With the generator standing level, check the engine oil level and top up if necessary. The oil level must be near to, but not exceed the high mark on the engine oil level dipstick.
- Put single/parallel switch in single position
- Check the coolant level in the expansion tank of the engine cooling system. The fluid level must be near to the FULL mark. Add coolant if necessary.
- Drain any fluid and sediment from the fuel pre-filter. Check the fuel level and top up if necessary. It is recommended to fill the tank after the day's operation to prevent fluid vapour in a nearly empty tank from condensing.
- Check the vacuum indicator of the air filter. If the red part shows completely, replace the filter element.
- Press the vacuator valve of the air filter to remove dust.
- Check the generator for leakage, tightness of wire terminals, etc. Correct if necessary.
- Check that fuse F4 is not activated and that the emergency stop is in the "OUT" position.
- Check that the load is switched off.
- Check that circuit breakers Q1.1 and Q1.2 are switched off.
- Check the correct position of the voltage selector switch (S10) on the alternator.
- Turn the battery switch to ON.

3.4 Starting

To start up the unit locally, without using the remote start/stop switch, proceed as follows:

- Put the starter switch in position P1. The unit starts a preheating cycle which takes 12 seconds.
- After the preheating period, the unit will start. The starting attempt will take maximum 12 seconds. If the unit does not start immediately, it will perform another two starting attempts.
- Approximately 15 seconds after starting (stabilization time for the generator), the timer relay closes the voltage free contact and the plant contactor is energized (if installed).
- Check that the warning lamps on the control and indicator panel are out. Refer to “Control and indicator panel” for component locations.
- Run the engine for approximately 5 minutes to warm up.
- Check the engine oil pressure (P9) and the coolant temperature (P8).
- Check the voltmeter P4 (with voltmeter selector switch S4 in different positions) and the frequency meter P5.
- Switch on circuit breaker Q1.1 or Q1.2, depending on the mode the generator is running in.
- Switch on the load and check the ammeters P1, P2 and P3, voltmeter P4 (voltmeter selector switch S4 in different positions) and the frequency meter P5.

To start up the unit from a remote location using the remote start/stop switch, proceed as follows:

- Put the starter switch in position P3.
- Switch on circuit breakers Q1.1 or Q1.2, depending on the type of generator, and the mode the unit is running in.
- Put the remote start/stop switch in position start. The unit starts a preheating cycle which takes 12 seconds.
- After the preheating period, the unit will start. The starting attempt will take maximum 12 seconds. If the unit does not start immediately, it will perform another two starting attempts.
- Approximately 15 seconds after starting (stabilization time for the generator), the timer relay closes the voltage free contact and the plant contactor is energized (if installed).
- Check that the warning lamps on the control and indicator panel are out. Refer to “Control and indicator panel” for component locations.
- Run the engine for approximately 5 minutes to warm up.
- Check the engine oil pressure (P9) and the coolant temperature (P8).
- Check the voltmeter P4 (with voltmeter selector switch S4 in different positions) and the frequency meter P5.
- Switch on the load and check the ammeters P1, P2 and P3, voltmeter P4 (voltmeter selector switch S4 in different positions) and the frequency meter P5.

3.5 During operation

Following points should be carried out regularly:

- Check the engine gauges and the lamps for normal readings.
-  **Avoid to let the engine run out of fuel. If it happened, priming will speed up the starting.**
- Check for leakage of oil, fuel or coolant.
 - Avoid long low-load periods (< 30 %). In this case, an output drop and higher oil consumption of the engine could occur.
 - Check, by means of the generator gauges, that the voltage between the phases is identical and that the rated current per phase is not exceeded.
 - When single-phase loads are connected to the generator output terminals, keep all loads well-balanced (in 3 phase output voltage mode).



Never turn the battery switch to OFF during operation.

- If circuit breakers are activated during operation, switch off the load and stop the generator. Check and, if necessary, decrease the load.
- The generator’s side doors may only remain opened for short periods during operation, to carry out checks for example.

3.6 Stopping

To stop the unit when the starter switch is in position P1, proceed as follows:

- Switch off the load.
- Switch off circuit breakers Q1.1 or Q1.2.
- Let the engine run for about 5 minutes.
- Stop the engine by putting the starter switch in position P2 or P4.

To stop the unit when the starter switch is in position P3, proceed as follows:

- Switch off the load.
- Let the engine run for about 5 minutes.
- Stop the engine by putting the remote start/stop switch in position stop or by putting the starter switch in position P2 or P4.



Lock the side doors and the door of the indicators and control panel to avoid unauthorized access.

4. Maintenance

 Before carrying out any maintenance activity, check that the start switch is in position O and that no electrical power is present on the terminals.

4.1 Maintenance schedule	Daily	Initial	Small	Normal	Yearly
		50 hours	250 hours	500 hours	2000 hours
Service pak	-	With unit	2912 4201 05	2912 4202 06	2912 4203 08
For the most important subassemblies, Atlas Copco has developed service kits that combine all wear parts. These service kits offer you the benefits of genuine parts, save on administration costs and are offered at reduced price, compared to the loose components. Refer to the parts list for more information on the contents of the service kits.					
Coolant level	Check	Check	Check	Check	Check
Tension and condition of drive belt(s)		Check	Check	Check	Replace
Radiator and intercooler fins		Check/Clean	Check/Clean	Check/Clean	Check/Clean
Fuel pre-filter/Fluid separator	Check/Drain	Replace	Replace	Replace	Replace
Fuel filter element		Replace	Replace	Replace	Replace
Fuel injectors					Check
Oil level in sump	Check	Check	Check	Check	Check
Oil pressure on gauge	Check	Check	Check	Check	Check
Lubrication oil		Change	Change	Change	Change
Oil filter(s)		Replace	Replace	Replace	Replace
Crankcase pressure (3mm WG at no load)				Check	Check
Vacum indicator	Check	Check	Check	Check	Check
Air cleaner and dust bowl		Clean	Clean	Clean	Clean
Air filter element (1)			Clean	Replace	Replace
Safety cartridge					Replace
Turbocharger impeller and housing					Clean/inspect
Fan hub bearings					Lubricate
Oil, fuel and fluid leaks		Check	Check	Check	Check
Mechanical links (e.g. fuel solenoid link)			Grease	Grease	Grease
Level battery electrolyte (2)		Check	Check	Check	Check
Condition of vibration dampers		Check	Check	Check	Check
Alternator insulation resistance (*)					Measure
Tightness of nuts and bolts		Check			Check
Door hinges and locks		Grease			Grease
Fixation of hoses, cables and pipes				Check	Check
Inspection by Atlas Copco Service technician					

(1) More frequently when operating in a dusty environment. Evacuate dust from the airfilter valve daily.

(2) A Service Bulletin (ASB) dealing elaborately with batteries and due care is available on request.

4.2 Engine maintenance

Refer to the engine's operator manual for full maintenance, including instructions for changing the oil and coolant and replacing the fuel, oil and air filters.

4.3 (*)Measuring the alternator insulation resistance

A 500 V megger is required to measure the alternator insulation resistance.

If the N-terminal is connected to the earthing system, it must be disconnected from the earth terminal. Disconnect the AVR. Disconnect the radio interference suppressor.

Connect the megger between the earth terminal and terminal L1 and generate a voltage of 500 V. The scale must indicate a resistance of at least 5 MΩ.

Refer to the alternator operating and maintenance instructions for more details.

4.4 Engine oil specifications



It is strongly recommended to use Atlas Copco branded lubrication oils.

High-quality, mineral, hydraulic or synthesized hydrocarbon oil with rust and oxidation inhibitors, anti-foam and anti-wear properties is recommended.

The viscosity grade should correspond to the ambient temperature and ISO 3448, as follows:

Type of lubricant	Engine
between 30°C (86°F) and 40°C (104°F)	PAROIL 15W40
between -5°C (23°F) and 30°C (86°F)	PAROIL 15W40
between -20°C (-4°F) and -5°C (23°F)	PAROIL 5W30



Never mix synthetic with mineral oil.

Remark:

When changing from mineral to synthetic oil (or the other way around), you will need to do an extra rinse.

After doing the complete change procedure to synthetic oil, run the unit for a few minutes to allow good and complete circulation of the synthetic oil. Then drain the synthetic oil again and fill again with new synthetic oil. To set correct oil levels, proceed as in normal instruction.

4.4.1 Specifications PAROIL

PAROIL from Atlas Copco is the ONLY oil tested and approved for use in all engines built into Atlas Copco compressors and generators. Extensive laboratory and field endurance tests on Atlas Copco equipment have proven PAROIL to match all lubrication demands in varied conditions. It meets stringent quality control specifications to ensure your equipment will run smoothly and reliably.

The quality lubricant additives in PAROIL allow for extended oil change intervals without any loss in performance or longevity.

PAROIL provides wear protection under extreme conditions. Powerful oxidation resistance, high chemical stability and rust-inhibiting additives help reduce corrosion, even within engines left idle for extended periods.

PAROIL contains high quality anti-oxidants to control deposits, sludge and contaminants that tend to build up under very high temperatures. PAROIL's detergent additives keep sludge forming particles in a fine suspension instead of allowing them to clog your filter and accumulate in the valve/rocker cover area.

PAROIL releases excess heat efficiently, whilst maintaining excellent bore-polish protection to limit oil consumption.

PAROIL has an excellent Total Base Number (TBN) retention and more alkalinity to control acid formation.

PAROIL prevents Soot build-up.

PAROIL is optimized for the latest low emission EURO -3 & -2, EPA TIER II & III engines running on low sulphur diesel for lower oil and fuel consumption.

4.4.2 PAROIL 5W30 and PAROIL 15W40

Synthetic engine oil PAROIL 5W30

PAROIL 5W30 is a Synthetic ultra high performance diesel engine oil with a high viscosity- index. Atlas Copco PAROIL 5W30 is designed to provide excellent lubrication from start-up in temperatures as low as -25°C (-13°F).

	Liter	US gal	Imp gal	cu.ft	Order number
can	5	1.3	1.1	0.175	1604 6060 00
barrel	210	55.2	46	7.35	1604 6059 00

Mineral engine oil PAROIL 15W40

PAROIL 15W40 is a mineral based high performance diesel engine oil with a high viscosity- index. Atlas Copco PAROIL 15W40 is designed to provide a high level of performance and protection in 'standard' ambient conditions as from -15°C (5°F).

	Liter	US gal	Imp gal	cu.ft	Order number
can	5	1.3	1.1	0.175	1615 5953 00
can	20	5.3	4.4	0.7	1615 5954 00
barrel	210	55.2	46	7.35	1615 5955 00

4.5 Engine oil level check

Consult the Engine Operation Manual for the oil specifications, viscosity recommendations and oil change intervals.

For intervals, see "Maintenance schedule" on page 16.

Check engine oil level according to the instructions in the Engine Operation Manual and if necessary top up with oil.

4.6 Engine oil and oil filter change

See section "Maintenance schedule" on page 16.

4.7 Engine coolant specifications



Never remove the cooling system filler cap while coolant is hot.

The system may be under pressure. Remove the cap slowly and only when coolant is at ambient temperature. A sudden release of pressure from a heated cooling system can result in personal injury from the splash of hot coolant.

It is strongly recommended to use Atlas Copco branded coolant.

The use of the correct coolant is important for good heat transfer and protection of liquid-cooled engines. Coolants used in these engines must be mixtures of good quality water (distilled or de-ionised), special coolant additives and if necessary freeze protection. Coolant that is not to manufacturer's specification will result in mechanical damage of the engine.

The freezing point of the coolant must be lower than the freezing point that can occur in the area. The difference must be at least 5°C (41°F). If the coolant freezes, it may crack the cylinder block, radiator or coolant pump.

Consult the engine's operation manual and follow the manufacturer's directions.



Never mix different coolants and mix the coolant components outside the cooling system.

4.7.1 Specifications PARCOOL EG

PARCOOL EG is the only coolant that has been tested and approved by all engine manufacturers currently in use in Atlas Copco compressors and generators.

Atlas Copco's PARCOOL EG extended life coolant is the new range of organic coolants purpose designed to meet the needs of modern engines. PARCOOL EG can help prevent leaks caused by corrosion. PARCOOL EG is also fully compatible with all sealants and gasket types developed to join different materials used within an engine.

PARCOOL EG is a ready to use Ethylene Glycol based coolant, premixed in an optimum 50/50 dilution ratio, for antifreeze protection guaranteed to -40°C (-40°F).

Because PARCOOL EG inhibits corrosion, deposit formation is minimized. This effectively eliminates the problem of restricted flow through the engine coolant ducts and the radiator, minimizing the risk for engine overheating and possible failure.

It reduces water pump seal wear and has excellent stability when subjected to sustained high operating temperatures.

PARCOOL EG is free of nitride and amines to protect your health and the environment. Longer service life reduces the amount of coolant produced and needing disposal to minimise environmental impact.

	Liter	US gal	Imp gal	cu.ft	Order number
can	5	1.3	1.1	0.175	1604 5308 00
can	20	5.3	4.4	0.7	1604 5307 01
barrel	210	55.2	46	7.35	1604 5306 00

To ensure protection against corrosion, cavitation and formation of deposits, the concentration of the additives in the coolant must be kept between certain limits, as stated by the manufacturer's guidelines. Topping up the coolant with water only, changes the concentration and is therefore not allowed.

Liquid-cooled engines are factory-filled with this type of coolant mixture.

4.8 Coolant check

4.8.1 Monitoring coolant condition

In order to guarantee the lifetime and quality of the product, thus to optimise engine protection, regular coolant-condition-analysis is advisable.

The quality of the product can be determined by three parameters.

Visual check

- Verify the outlook of the coolant regarding colour and make sure that no loose particles are floating around.

pH measurement

- Check the pH value of the coolant using a pH-measuring device.
- The pH-meter can be ordered from Atlas Copco with part number 2913 0029 00.
- Typical value for EG = 8.6.
- If the pH-level is below 7 or above 9.5, the coolant should be replaced.

Glycol concentration measurement

- To optimise the unique engine protection features of the PARCOOL EG the concentration of the Glycol in the water should be always above 33 vol.%.
- Mixtures with more than 68 vol.% mix ratio in water are not recommended, as this will lead to high engine operating temperatures.
- A refractometer can be ordered from Atlas Copco with part number 2913 0028 00.



In case of a mix of different coolant products this type of measurement might provide incorrect values.

4.8.2 Topping up of coolant

- Verify if the engine cooling system is in a good condition (no leaks, clean,...).
- Check the condition of the coolant.
- If the condition of the coolant is outside the limits, the complete coolant should be replaced (see section 4.8.3 Replacing the coolant).
- Always top-up with PARCOOL EG.
- Topping up the coolant with water only, changes the concentration of additives and is therefore not allowed.

4.8.3 Replacing the coolant

Drain

- Completely drain the entire cooling system.
- Used coolant must be disposed or recycled in accordance with laws and local regulations.

Flush

- Flush twice with clean water. Used coolant must be disposed or recycled in accordance with laws and local regulations.
- From the Atlas Copco Instruction book, determine the amount of PARCOOL EG required and pour into the radiator top tank.
- It should be clearly understood that the risk for contamination is reduced in case of proper cleaning.
- In case a certain content of ‘other’ coolant remains in the system, the coolant with the lowest properties influences the quality of the ‘mixed’ coolant.

Fill

- To assure proper operation and the release of trapped air, run the engine until normal engine operation temperature is reached. Turn off the engine and allow to cool.
- Recheck coolant level and add if necessary.

5. Storage of the generator

5.1 Storage

- Store the generator in a dry, frost-free room which is well ventilated.
- Run the engine regularly, e.g. once a week, until it is warmed up. If this is impossible, extra precautions must be taken:
 - Consult the engine's operator manual.
 - Remove the battery. Store it in a dry, frost-free room. Keep the battery clean and its terminals lightly covered with petroleum jelly. Recharge the battery regularly.
 - Clean the generator and protect all electrical components against moisture.
 - Place silica gel bags, VCI paper (Volatile Corrosion Inhibitor) or another drying agent inside the generator and close the doors.
 - Stick sheets of VCI paper with adhesive tape on the bodywork to close off all openings.
 - Wrap the generator, except the bottom, with a plastic bag.

5.2 Preparing for operation after storage

Before operating the generator again, remove the wrapping, VCI paper and silicagel bags and check the generator thoroughly (go through the checklist "Before starting").

- Consult the engine's operator manual.
- Check that the insulation resistance of the generator exceeds 5 M Ω .
- Replace the fuel filter and fill the fuel tank. Vent the fuel system.
- Reinstall and connect the battery, if necessary after being recharged.
- Submit the generator to a test run.

6. Checks and trouble shooting



Never perform a test run with connected power cables. Never touch an electrical connector without a voltage check.

When a failure occurs, always report what you experienced before, during and after the failure. Information with regard to the load (type, size, power factor, etc.), vibrations, exhaust gas colour, insulation check, odours, output voltage, leaks and damaged parts, ambient temperature, daily and normal maintenance and altitude might be helpful to quickly locate the problem. Also report any information regarding the humidity and location of the generator (e.g. close to sea).

6.1 Checking voltmeter P4

- Put a voltmeter in parallel with voltmeter P4 on the control panel.
- Check that the read-out of both voltmeters is the same.
- Stop the generator and disconnect one terminal.
- Check that the internal resistance of the voltmeter is high.

6.2 Checking frequency meter P5

- Run the unit at normal speed.
- Put a voltmeter in parallel with frequency meter P5.
- If the measured voltage is higher than 240 V, the frequency meter has to work properly.

If not, remove the frequency meter, connect it with the mains (240 V) and check that it indicates 60 Hz.

6.3 Checking ammeters P1, P2 and P3

- Measure during the load, by means of a clamp-on probe, the outgoing current in the three phases.
- Compare the measured current with the current indicated on ammeters on the corresponding ammeters P1, P2 and P3. Both readings should be the same.

6.4 Alternator trouble shooting

Symptom	Possible cause	Corrective action
<i>Alternator does not excite</i>	Blown fuse. Insufficient residual voltage. No residual voltage.	Replace fuse. Increase the speed by 15 %. For an instant apply on the + and – terminals of the electronic regulator a 12 V battery voltage with a 30 Ω resistor in series respecting the polarities.
<i>After being excited alternator does not excite</i>	Connections are interrupted.	Check connection cables as per attached drawings.
<i>Low voltage at no load</i>	Voltage potentiometer out of setting. Intervention of protection. Winding failure.	Reset voltage. Check rpm. Check windings.
<i>High voltage at no load</i>	Voltage potentiometer out of setting. Failed regulator.	Reset voltage. Substitute regulator.
<i>Lower than rated voltage at load</i>	Voltage potentiometer out of setting. Intervention by protection. Failed regulator. Rotating bridge failure.	Reset voltage potentiometer. Current too high, power factor lower than 0.8; speed lower than 10 % of rated speed. Substitute regulator. Check diodes, disconnect cables.
<i>Higher than rated voltage at load</i>	Voltage potentiometer out of setting. Loose sensing wires on AVR. Failed regulator.	Reset voltage potentiometer. Check sensing wires on AVR. Substitute regulator.
<i>Unstable voltage</i>	Speed variation in engine. Regulator out of setting.	Check regularity of rotation. Regulate stability of regulator by acting on “STABILITY” potentiometer.
<i>Engine runs in idle speed</i>	No SAPE connected.	Put single/parallel switch in single position.

6.5 Engine trouble shooting

A first fault diagnose can be read on the check engine light (L7) and the engine stop light (L6). For more detailed information refer to the Engine operating manual. An extensive Engine troubleshooting manual is available at Detroit Diesel. For more information contact Detroit Diesel.

The DDEC reader is a useful tool for troubleshooting.

6.5.1 Engine diagnostic codes

To read the engine diagnostic codes, connect the diagnostic data reader to the diagnostic data socket (X20) or depress and hold the diagnostic request switch with the ignition on, the engine at idle or not running. Press and hold the switch.

Active codes will be flashed on the stop engine light, followed by the inactive codes being flashed on the check engine light. The cycle will repeat until the diagnostic request switch is released.

The flash code contains 2 digits:

- the first digit is the number of times L6 or L7 flashes slowly,
- the second digit is the number of times L6 or L7 flashes fast.

Flash code	Code description
11	VSG input low
12	VSG input high
13	Coolant level circuit low
14	Intercooler, coolant or oil temperature circuit high
15	Intercooler, coolant or oil temperature circuit low
16	Coolant level circuit high
17	Bypass position circuit high
18	Bypass position circuit low
21	TPS circuit high
22	TPS circuit low
23	Fuel temperature circuit high
24	Fuel temperature circuit low
25	No codes
26	Auxiliary shutdown #1 or #2 active
27	Air temperature circuit high
28	Air temperature circuit low
31	Auxiliary output short or open circuit (high side)
32	SEL short or open circuit
33	Boost pressure circuit high
34	Boost pressure circuit low
35	Oil pressure circuit high
36	Oil pressure circuit low
37	Fuel pressure circuit high
38	Fuel pressure circuit low
41	Too many SRS (missing TRS)
42	Too few SRS (missing SRS)
43	Coolant level low
44	Intercooler, coolant or oil temperature high
45	Oil pressure low

Flash code	Code description
46	Battery voltage low
47	Fuel pressure high
48	Fuel pressure low
52	A/D conversion fail
53	EEPROM write or nonvolatile checksum fail
54	Vehicle speed sensor fault
55	J1939 data link fault
56	J1587 data link fault
57	J1922 data link fault
58	Torque overload
61	Injector response time long
62	Auxiliary output open or short to battery
63	PWM open or short to battery
64	Turbo speed circuit failed
67	Coolant pressure circuit high or low
68	IVS switch fault, open or grounded circuit
71	Injector response time short
72	Vehicle overspeed
75	Battery voltage high
76	Engine overspeed with engine brake
81	Oil level or crankcase pressure circuit high
82	Oil level or crankcase pressure circuit low
83	Oil level or crankcase pressure high
84	Oil level or crankcase pressure low
85	Engine overspeed
86	Fluid pump or barometer pressure circuit high
87	Fluid pump or barometer pressure circuit low
88	Coolant pressure low

7. Technical specifications

7.1 Readings on gauges

<i>Gauge</i>	<i>Reading</i>	<i>US</i>	<i>Metric</i>
Ammeter L1 (P1)	Below max. rating	A	A
Ammeter L2 (P2)	Below max. rating	A	A
Ammeter L3 (P3)	Below max. rating	A	A
Voltmeter (P4)	Depends upon selector switch	V	V
Frequency meter (P5)	Between 60 and 62.5	Hz	Hz
Hourmeter (P6)	Adding up	h	h
Fuel level (P7)	Above 0	Fuel tank full	Fuel tank full
Engine temperature (P8)	Below 221°F or 105°C	°F	°C
Engine oil pressure (P9)	Below maximum rating	psi	bar

7.2 Settings of switches

<i>Switch</i>	<i>Function</i>	<i>Activates at</i>	<i>Activates at</i>
Engine oil pressure	shut down	7.25 psi	0.5 bar
Engine coolant temperature	shut down	221°F	105°C

7.3 Specifications of the engine/alternator/unit

		<i>US</i>	<i>Metric</i>
<i>Reference conditions</i> 1) 4)	Rated frequency	60 Hz	60 Hz
	Rated speed	1800 rpm	1800 rpm
	Generator service duty	PRP	PRP
	Absolute inlet pressure	100 kPa	100 kPa
	Relative air humidity	30 %	30 %
	Air inlet temperature	77°F	25°C
<i>Limitations</i> 2)	Maximum ambient temperature	122°F	50°C
	Altitude capability	12,008.46 ft	3660 m
	Relative air humidity maximum	< 100 %	< 100 %
	Minimum starting temperature unaided	-0.4°F	-18°C
	Minimum starting temperature with heater	-13°F	-25°C
<i>Performance data</i> 2) 3) 4) 5)	Rated active power (PRP) 3ph	193.10 hp	144 kW
	Rated active power (PRP) 1ph (optional)	157.97 hp	117.8 kW
	Rated power factor (lagging) 3ph	0.8	0.8
	Rated power factor (lagging) 1ph (optional)	1.0	1.0
	Rated apparent power (PRP) 3ph	180 kVA	180 kVA
	Rated apparent power (PRP) 1ph (optional)	117.8 kVA	117.8 kVA
	Rated voltage 3ph line to line	480 V	480 V
	Rated voltage 3ph line to line lower voltage (optional)	208 V	208 V
	Rated voltage 1ph line to line	240 V	240 V
	Rated current 3ph	216.5 A	216.5 A
	Rated current 3ph lower voltage (optional)	499.6 A	499.6 A
	Rated current 1ph (optional)	490.7 A	490.7 A
	Performance class (acc.ISO 8528-5:1993)	G2	G2
	Single step load acceptance (0-PRP)	100 %	100 %
	Frequency droop	isochronous	isochronous
	Fuel consumption at full load/no load (PRP)	73.21/16.54 lb/h	33.2/7.5 kg/h
	Specific fuel consumption at full load (PRP)	0.51 lb/kWh	0.23 kg/kWh
	Fuel autonomy at full load (PRP)	12.4 h	12.4 h
	Max. oil consumption at full load (PRP)	1.53 oz/h	43.8 g/h
	Maximum sound power level (LWA) measured (at 75% PRP load) according to 2000/14/EC OND	100 dB(A)	100 dB(A)
Capacity of fuel tank	125.93 Usgal	477 l	
Single step load capability (0-PRP)	100 %	100 %	

<i>Application data</i>	Mode of operation	PRP	PRP
	Site	land use	land use
	Operation	single	single
	Start-up and control mode	manual/remote	manual/remote
	Start-up time	unspecified	unspecified
	Mobility/ Config. acc. to ISO 8528-1:1993	transportable/D	transportable/D
	Mounting	fully resilient	fully resilient
	Climatic exposure	open air	open air
	Degree of protection (cubicle)	IP54	IP54
Status of neutral	earthed	earthed	
<i>Alternator</i>	Standard	IEC34-1	IEC34-1
		ISO 8528-3	ISO 8528-3
	Make	MECC ALTE	MECC ALTE
	Model	ECO 37-1S	ECO 37-1S
	Rated output, class H temp. rise	204 kVA	204 kVA
	Degree of protection	IP 21	IP 21
	Insulation stator class	H	H
	Insulation rotor class	H	H
Number of wires	12	12	
<i>Engine</i>	Standard	ISO 3046	ISO 3046
		ISO 8528-2	ISO 8528-2
	Type DETROIT DIESEL	S50	S50
	Rated net output	209.20 hp	156 kW
	Rating type acc. ISO 3046-7	ICXN	ICXN
	Production tolerance	+/- 5%	+/- 5%
	Coolant	water	water
	Combustion system	direct injection	direct injection
	Aspiration	turbocharged	turbocharged
		intercooled	intercooled
	Number of cylinders	4	4
	Swept volume	2.24 Usgal	8.5 l
	Speed governing	electronic	electronic
	Capacity of oil sump	6.86 Usgal	26 l
	Capacity of cooling system	9.24 Usgal	35 l
Electrical system	24 Vdc	24 Vdc	
<i>Power circuit</i>	Circuit-breaker, 3ph		
	Number of poles (optional)	3	3
	Thermal release It	215 A	215 A
	Magnetic release Im	3..10xIn	3..10xIn
	Circuit-breaker, 3ph, lower voltage		
	Number of poles (optional)	3	3
	Thermal release It	500 A	500 A
Magnetic release Im	3..10xIn	3..10xIn	
<i>Outlet sockets</i>			GFCI duplex (1x) 2p+E 20A 125V
			Temp Power (2x) 2p+N+E 50 A 125/250 V
<i>Unit</i>	Dimensions (LxWxH)	135.33 x 55.77 x 83.07 in	3470 x 1430 x 2130 mm
	Weight net mass	8544.38 lb	3875 kg
	Weight wet mass	9249.98 lb	4195 kg

Derating table (in %, 100% is declared power at "Performance data")

Height (m)	Temperature (°C)					
	25	30	35	40	45	50
100	101	100	99	98	97	96
500	101	100	99	98	97	96
1000	100	99	98	97	96	95
1500	98	97	96	95	94	93
2000	98	97	96	95	94	93
2500	97	96	95	94	92	88
3000	96	95	94	93	92	88
3660	94	94	88	88	84	80

Notes

- 1) Reference conditions for engine performance to ISO 3046-1.
- 2) See derating diagram or consult the factory for other conditions.
- 3) At reference conditions unless otherwise stated.
- 4) Rating Definition (ISO 8528-1):
 - LTP: Limited Time Power is the maximum electrical power which a generating set is capable of delivering (at variable load), in the event of a utility power failure (for up to 500 hours per year of which a maximum of 300 hours is continuous running). No overload is permitted on these ratings. The alternator is peak continuous rated (as defined in ISO 8528-3) at 25°C (77°F).
 - PRP: Prime Power is the maximum power available during a variable power sequence, which may be run for an unlimited number of hours per year, between stated maintenance intervals and under the stated ambient conditions. A 10% overload is permitted for 1 hour in 12 hours. The permissible average power output during a 24h period shall not exceed the stated load factor of 80%.
- 5) Specific mass fuel used: 0.86 kg/l (1.90 lb/Usgal).

7.4 Conversion list of SI units into British units

1 bar	=	14.504 psi	1 m	=	3.281 ft
1 g	=	0.035 oz	1 mm	=	0.039 in
1 kg	=	2.205 lb	1 m ³ /min	=	35.315 cfm
1 km/h	=	0.621 mile/h	1 mbar	=	0.401 in wc
1 kW	=	1.341 hp (UK and US)	1 N	=	0.225 lbf
1 l	=	0.264 US gal	1 Nm	=	0.738 lbf.ft
1 l	=	0.220 imp gal (UK)	t_{oF}	=	$32 + (1.8 \times t_{oC})$
1 l	=	0.035 cu.ft	t_{oC}	=	$(t_{oF} - 32)/1.8$

– A temperature difference of 1°C = a temperature difference of 1.8°F

7.5 Dataplate

The diagram shows a rectangular dataplate for an Atlas Copco Airpower unit. It contains the following information:

- Top section: **ATLAS COPCO AIRPOWER n.v.** (4), followed by a 5-digit EEC or national type approval number (5), and a 17-digit Vehicle Identification Number (6) starting with **-YA3-**.
- Weight specifications: ****** kg** (7) with three boxes labeled **A**, **B**, and **C**.
- Technical specifications table:

Model/Modell/Modèle	*****	7
f N	*** * Hz **	8
P N	*** * kVA ***	9
P N	* kW ***	10
U N	* V ***	11
I N	* A ***	12
cos phi	**	13
Manuf. year/Baujahr/Année de fabrication	****	14
- Bottom section: **MADE BY ATLAS COPCO AIRPOWER n.v. WILRIJK, BELGIUM** (15), the **CE** mark (16), the **Atlas Copco** logo (17), and the number **115 6945 00**.

Legend for A, B, and C:

- A Maximum permitted loaden weight of the vehicle
- B Maximum permitted road weight of the front axle
- C Maximum permitted road weight of the rear axle

Legend for 1-17:

- 1 Company code
- 2 Product code
- 3 Unit serial number
- 4 Name of the manufacturer
- 5 EEC or national type approval number
- 6 Vehicle identification number
- 7 Model number
- 8 Frequency
- 9 Apparent power - PRP
- 10 Active power - PRP
- 11 Nominal rated voltage
- 12 Nominal rated current
- 13 Power factor
- 14 Manufacturing year
- 15 EEC mark in accordance with Machine Directive 89/392E
- 16 Mode of operation
- 17 Winding connections

Circuit diagrams

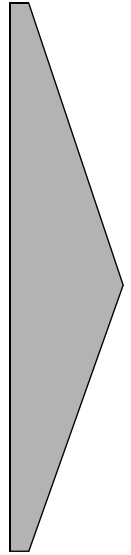

CIRCUIT DIAGRAM

9822 0889 05/11
Applicable for QAS 186 GdS USA, Power Circuit Diagram

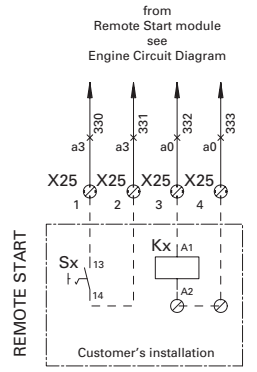
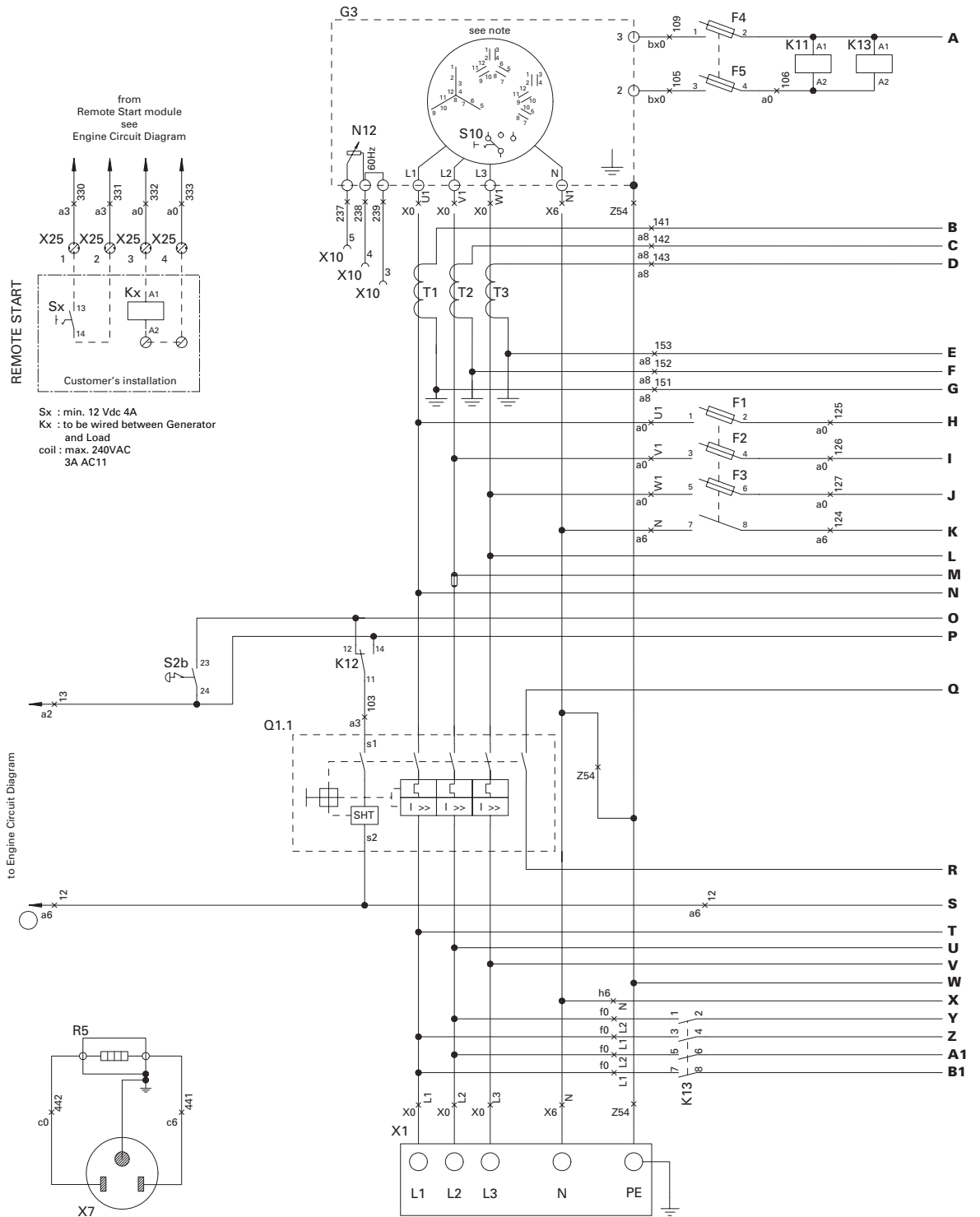

Sx : min. 12 Vdc 4A
 Kx : to be wired between Generator and Load
 coil : max. 240VAC 3A AC11

to Engine Circuit Diagram

F1-5	Fuse 4A	Q1.2	Circuit breaker 3-pole	X2	Socket outlet
G3	Alternator	Q2	Circuit breaker 1-pole	X3	Socket outlet
K11	Auxiliary relay (lower voltage)	Q3	Circuit breaker 2-pole	X4	Socket outlet
K12	Auxiliary relay (higher voltage)	Q4	Circuit breaker 2-pole	X7	Flanged inlet
K13	Contactor	R5	Coolant heater	X25	Terminal strip
N12	Automatic voltage regulator	S2b	Emergency stop (S2a see Engine Circ.)	X33	Par. connector to control cub. (SAPE)
P1-3	Amperemeter	S4	Voltmeter change-over switch	Sx	Remote start/stop switch
P4	Voltmeter 0-500V	S10	Supply voltage switch	Kx	Plant contactor
P5	Frequencymeter 45-65Hz	T1-3	Current transformer	(O)	Optional equipment
Q1.1	Circuit breaker 3-pole	X1	Terminal board		

CIRCUIT DIAGRAM

9822 0889 08/11
Applicable for QAS 186 GdS USA

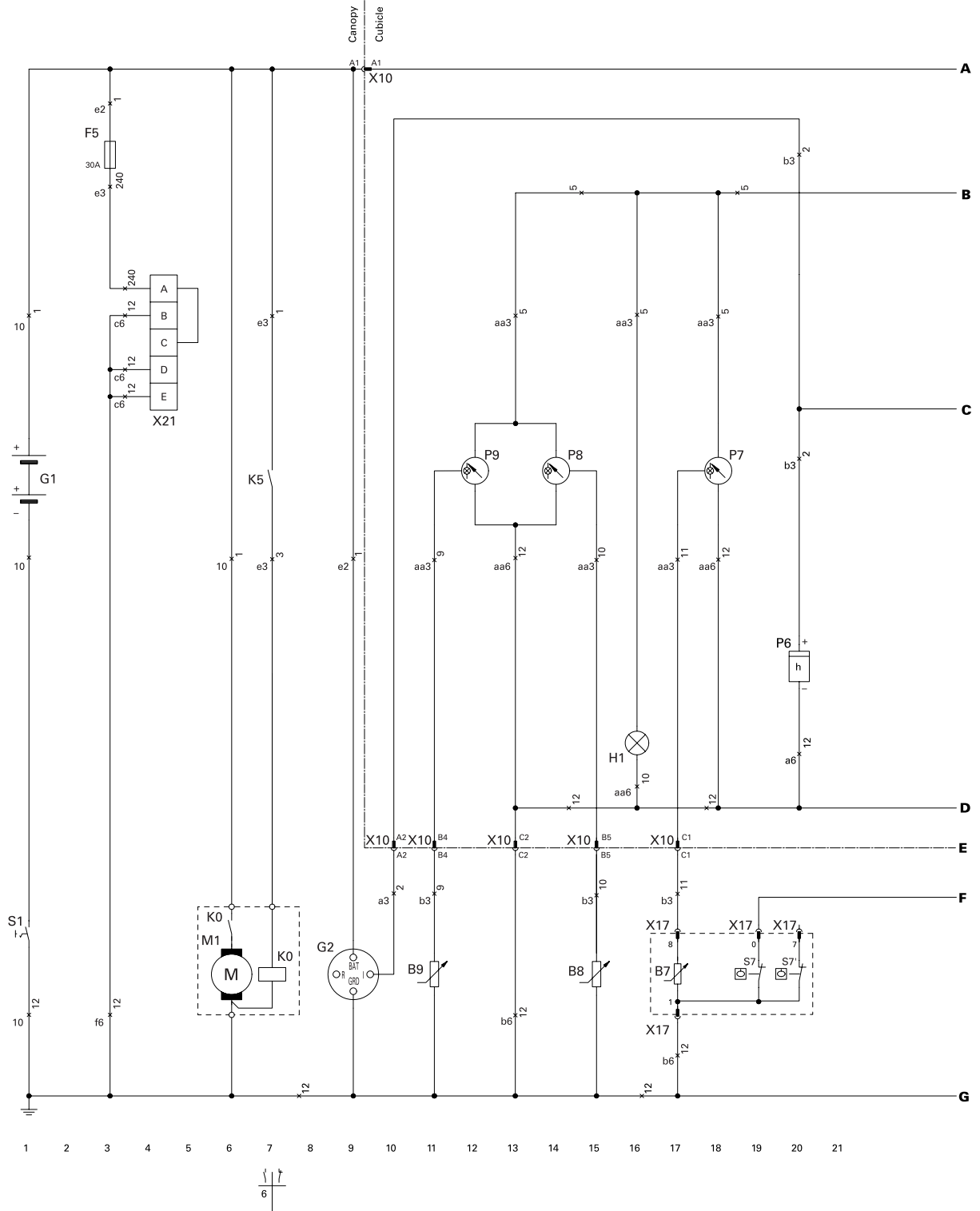

B7	Fuel level sensor	H1	Panel light	P7	Fuel level gauge
B8	Coolant temperature sensor	K0	Starter solenoid	P8	Coolant temperature gauge
B9	Oil pressure sensor	K5	Starter relay	P9	Oil pressure gauge
B10	Coolant level switch	M1	Starter motor	R1, 2	Resistor
F4	Fuse 10A	N4	Control module	R11	Voltage adjust
F5	Fuse 30A	N5	Instrument cluster	S1	Battery switch
G1	Battery 24V	N6	Instrument cluster	S2	Emergency stop button
G2	Charging generator	P6	Hourmeter	S6	Low coolant level switch

CIRCUIT DIAGRAM

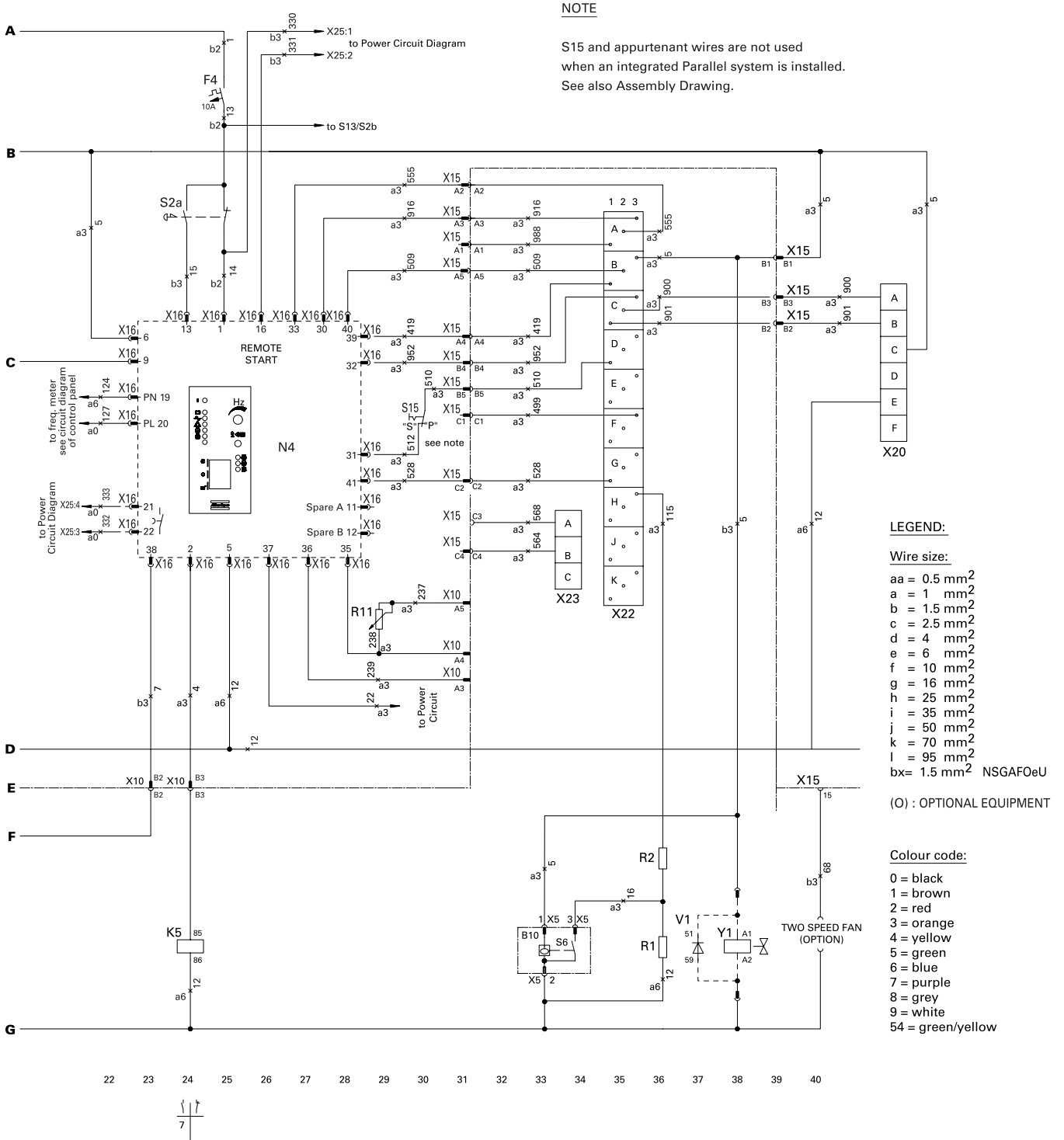

S7	Low fuel level switch	X15	15-pole connector
S7'	Low fuel level switch, warning	X16	Control module connector
S15	Single/parallel switch (See note)	X17	Fuel level unit connector
V1	Diode	X18	Instrument cluster connector
X10	15-pole connector	X19	Instrument cluster connector
X11	Coolant level switch connector	X20	Diagnostic data socket (DDEC)
		X21	Power connector (DDEC)
		X22	30-pole connector (DDEC)
		X23	Engine sensor harness connector (DDEC)
		Y1	Solenoid valve for automatic oiler
		note:	S15 and appurtenant wires are not used when an integrated Parallel system is installed. See also Assembly Drawing.



www.atlascopco.com

Printed in Belgium 06/2005 - 2954 0220 01

**Instruction Manual
for AC Generators**

QAS 186 GdS USA

