

CLASS 300 EQUIPMENT BE3-25A AUTO-SYNCHRONIZER (Single Phase)

DEVICE NUMBER: 25A

APPLICATION:

In applications requiring parallel operation of multiple generators or a single generator to an energized station bus, the BE3-25A automatically synchronizes the oncoming generator to the bus. The automatic synchronizer monitors the voltage on each side of the generator circuit breaker and determines when the proper phase relationship exists between the generator voltage and bus voltage. If the phase angle, frequency, and voltage magnitude of the oncoming generator, with respect to the station bus, are not within the tolerances allowed for proper synchronizing, the automatic synchronizer provides frequency and voltage correction signals through summing point signals or raise/lower output contacts prior to circuit breaker closure.

Many emergency generator systems require the first generator to automatically close onto a de-energized bus prior to synchronizing additional generators. The BE3-25A includes an optional dead-bus feature for this application.

FEATURES:

- Generator frequency, phase angle, and voltage matching through either bipolar corrective signals or raise/lower corrective output contacts.
- Frequency matching capture range is ± 3 Hertz of the bus frequency.
- Dead-bus closing option.
- Qualified to the requirements IEEE C37.90a-1974 Surge Withstand Capability and IEC 255-5, 6, and 20.
- CSA approved, UL recognized.
- Automatic or remote reset of corrective signals.
- Bipolar correction signal provides direct control of Basler Electric voltage regulator.
- Built-in operational test.
- Mechanically rugged and compact, high reliability.
- 18 month warranty.
- Available from stock.

APPLICATION AND FEATURES

this page

DESCRIPTION AND SPECIFICATIONS

pages 2 and 3

INTERCONNECT DRAWINGS

pages 4-7

OUTLINE DRAWING

page 8

ORDERING INFORMATION

page 8

INSTRUCTION MANUAL

Reference
Publication Number
9 1661 00 990

B Basler Electric

P. O. BOX 269 HIGHLAND, ILLINOIS 62249, U.S.A. PHONE 618-654-2341 FAX 618-654-2351

UMP-5
10-95

DESCRIPTION:

The basic BE3-25A monitors the oncoming generator and bus voltages and permits synchronizing the generator to an energized station bus or another generator when the following predetermined conditions are satisfied:

- A) The slip frequency is ± 0.1 hertz or less.
- B) The phase angle differential is equal to or less than the selected setting ranging from $\pm 5^\circ$ to $\pm 20^\circ$ adjustable in five degree increments.
- C) The generator and bus voltage differential is less than the selected voltage difference setting continuously adjustable ranging from $\pm 5\%$ to $\pm 15\%$ of the bus voltage.

When a jumper is connected across the 0.75 second time delay terminals of the unit, the automatic synchronizer will synchronize the generator when the generator voltage is within the selected voltage difference setting and the measured phase angle and slip frequency are less than the following:

Phase Angle Setting	Max. Slip Frequency
$\pm 5^\circ$	$\pm .037$ Hz
$\pm 10^\circ$	$\pm .074$ Hz
$\pm 15^\circ$	$\pm .1$ Hz
$\pm 20^\circ$	$\pm .1$ Hz

When the phase angle, frequency, and voltage are within predetermined limits, the automatic synchronizer energizes the isolated synchronizing output relay initiating generator circuit breaker closure, illuminates the sync LED and immediately resets the frequency and phase angle correction signals. The correction signal can be reset when desired by installing a normally open contact between the reset terminals of the synchronizer. Closure of this contact, together with the energization of the synchronizing output relay for breaker closure, will reset the correction output signals.

FREQUENCY MATCHING: Five frequency matching options are available. The synchronizer will provide correction signals when the phase angle and/or slip frequency exceed the settings. These signals cause the governor to increase or decrease the prime mover's speed.

Five frequency options are available:

TYPE A: Provides a low voltage signal to AMBAC International governors, type CU673C.

TYPE B: Provides a proportional bipolar signal to Barber Colman governors, types DYN1, ILS.

TYPE C: Provides contact outputs for motor operated control operation.

TYPE W: Provides a proportional bipolar signal to Woodward governors, types 1712-1724, 2301, 2301A.

The correction signals are proportional to the magnitude of the slip frequency and phase angle, and continue until the conditions for breaker closure are satisfied. Frequency correction signals are at maximum until the generator frequency is within ± 3 hertz of the station bus frequency. This then becomes proportional.

VOLTAGE MATCHING: If optional voltage matching is specified, the synchronizer provides correction signals to the generator regulator when the difference between the generator and bus voltages exceeds the predetermined front panel setting.

Two types of voltage correction signals are optionally available:

OPTION 1: Bipolar correction signal (proportional to the magnitude of monitored voltage difference) for use with summing point input Basler voltage regulator; Types SSR, SR, KR, and XR; and exciter regulators, Types SSE and SER-CB.

OPTION 2: Raise/lower output contacts provide control signals for a motor operated control.

The value of allowable difference for breaker closure is selectable in 1% increments over the range of $\pm 1\%$ to $\pm 5\%$ by adjusting a printed circuit board mounted switch accessible from the front panel. The corrective signals are continuous until conditions for breaker closure are satisfied.

DEAD BUS: Selection of the dead bus feature enables the BE3-25A to close the circuit breaker connecting the oncoming generator to a de-energized bus. The dead bus voltage is continuously adjustable from 10 to 50 Vac (at 120V tap) by a printed circuit board mounted potentiometer accessible from the front panel. The dead bus option is inhibited from operation by removal of the jumper connected across the dead bus terminals.

SPECIFICATIONS:

Electrical:

POWER SUPPLY: Designed to receive its input through a jumper connection from either the generator voltage input terminals or bus voltage input terminals. A front panel light emitting diode (LED) illuminates to indicate the power supply is providing normal operation voltages to the synchronizer. A decrease of the input voltage to the power supply below 80 Vac causes the synchronizer to remove all correction signals to the controlled electronic governor and voltage regulator.

POWER SUPPLY		
Maximum Operating Range	Frequency	Burden
80 - 140 Vac 180 - 264	50 Hz	7 VA
87 - 153 Vac 186 - 304	60 Hz	7 VA

SENSING INPUT: The generator and bus voltage input sensing circuits impose a maximum of 2 VA burden on the potential transformers at nominal voltage. The generator and bus inputs are rated for 150% of nominal input for a time period of two seconds. Table 1 defines the sensing input range for the monitored generator and bus voltages.

Sensing Input Range		
120 Vac	240 Vac	Burden
80-153 Vac	180-304 Vac	2VA

TABLE 1

RATED FREQUENCY: 50/60 Hz

BREAKER CLOSURE: Contact rated for 4 amps at 120 Vac or 28 Vdc (resistive); 4 amps at 220 Vac (resistive).

FREQUENCY/PHASE ANGLE MATCHING

CORRECTION SIGNALS:

Raise/Lower Contact: Continuous contact closure signal. Contacts rated: 2 amps at 240 Vac (resistive), or 28 Vdc 2 amps (resistive), 1/3 HP at 120 Vac.

Summing Point: ± 4 Vdc (maximum) bipolar signal compatible with Barber Colman electronic summing point governors. American Bosch electronic governors $+ 5 \pm 4$ Vdc. Woodward electronic governors ± 6 Vdc (maximum) bipolar. All outputs are isolated.

VOLTAGE MATCHING:

Raise/Lower Contact: Continuous contact closure signal. Contacts rated: 2 amps at 240 Vac (resistive) or 28 Vdc 2 amps (resistive) 1/3 HP at 120 Vac.

Summing Point: Bipolar signal compatible with Basler Electric voltage regulator, types SR, SSR, KR, and XR; and exciter regulators types SSE and SER-CB.

BREAKER CLOSING ANGLE: $\pm 5^\circ$ to $\pm 20^\circ$ range adjustable in 5° increments.

VOLTAGE ACCEPTANCE:

Basic Synchronizer: $\pm 5\%$ to $\pm 15\%$ of the bus voltage front panel accessible continuous adjustment.

Optional Voltage Matching Differential: 1 - 5% adjustable in 1% increments. Front panel accessible switch.

DEAD BUS:

Dead bus voltage level is continuously adjustable over the range of 10 to 50 Vac $\pm 5\%$ (at the 120 Vac tap) by a front panel accessible potentiometer.

Physical:

OPERATING TEMPERATURE: -40°C (-40°F) to 70°C (158°F).

STORAGE TEMPERATURE: -65°C (-85°F) to 85°C (185°F).

SHOCK: Withstand 15G's in each of three mutually perpendicular axis.

FINISH: Dark gray, textured, baked enamel.

WEIGHT: 4 lbs. (1.82kg).

VIBRATION: Tested and withstands the following:

Frequency	Level
5-18 Hz	0.06 inch double amplitude
18-30 Hz	1 G
30-48 Hz	0.02 inch double amplitude
48-70 Hz	2.5 G's

**INTERCONNECTION:
Output Breaker (Sync) Connection**

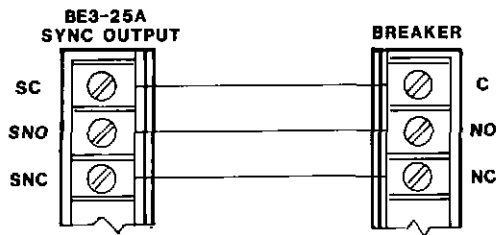
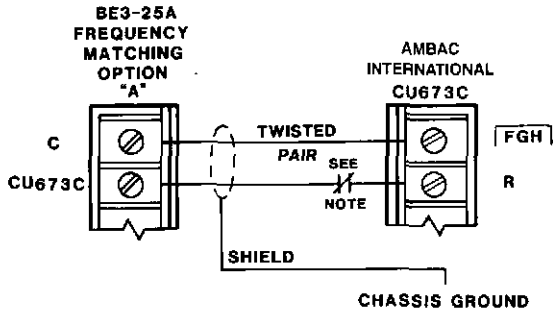

FIGURE 1 – SYNC OUTPUT CONNECTION

Summing Point Governor



NOTE:
A NORMALLY CLOSED CONTACT IS NEEDED BETWEEN THE SYNCHRONIZER AND PIN 'R' WHICH OPENS AFTER SYNC OR WHEN POWER IS REMOVED FROM THE BE 3-25A.

FIGURE 2 –AMBAC INTERNATIONAL CU673C INTERCONNECTION

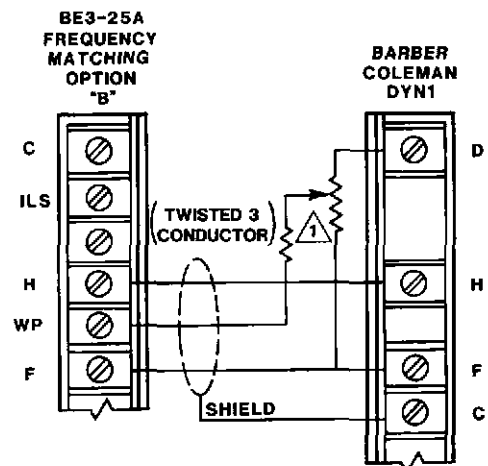

NOTE: Δ 1 SEE GOVERNOR MANUAL FOR VALUE OF RESISTORS.

FIGURE 3 – BARBER-COLEMAN DYN1 INTERCONNECTION

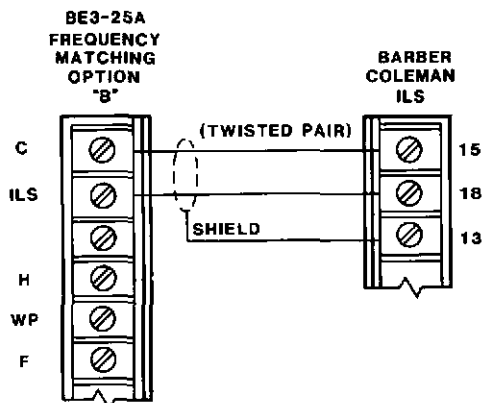

FIGURE 4 – BARBER-COLEMAN ILS INTERCONNECTION

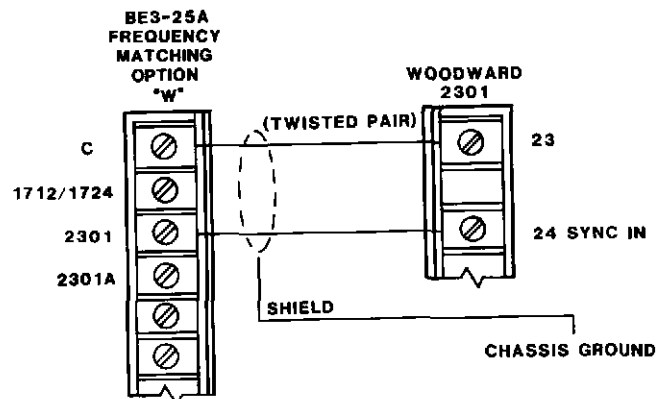

FIGURE 5 – WOODWARD 2301 INTERCONNECTION

**INTERCONNECTION:
Summing Point Governor (continued)**

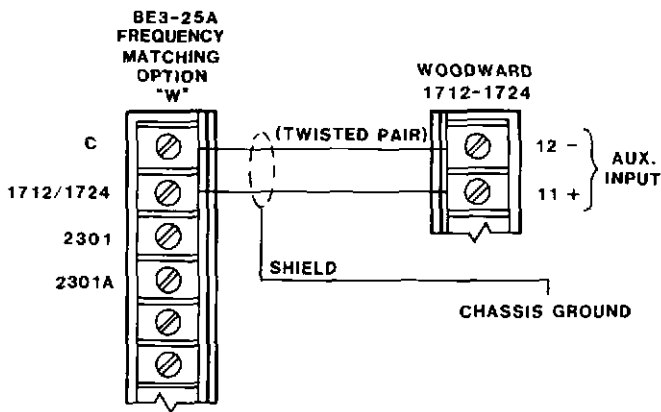

FIGURE 6 – WOODWARD 1712-1724 INTERCONNECTION

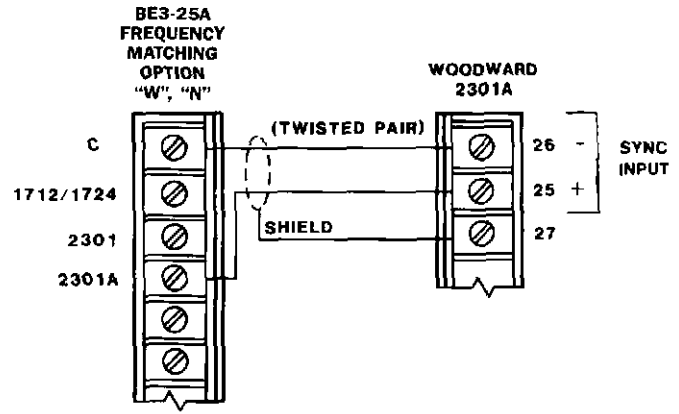
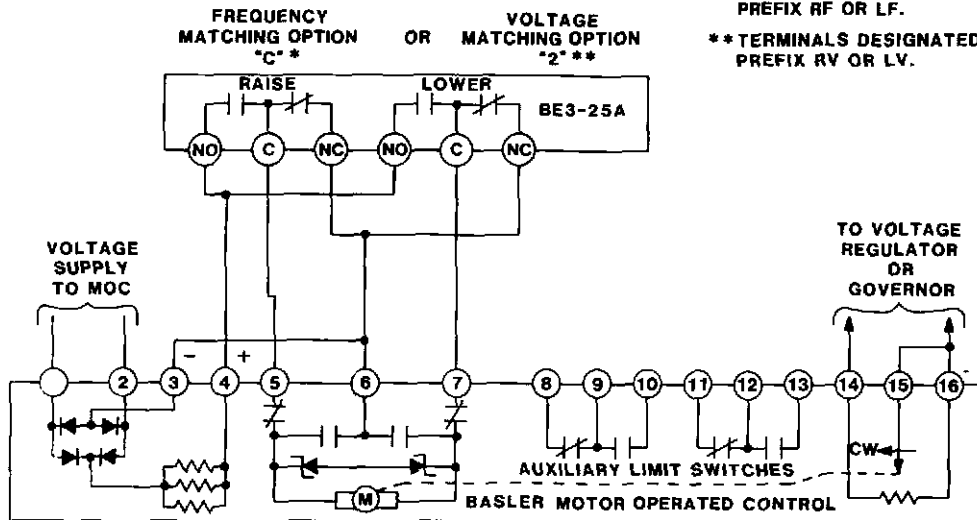

FIGURE 7 – WOODWARD 2301 A INTERCONNECTION

Raise/Lower Contacts – Voltage Regulator/Governor



NOTES:
* TERMINALS DESIGNATED WITH PREFIX RF OR LF.
** TERMINALS DESIGNATED WITH PREFIX RV OR LV.

FIGURE 8 – RAISE/LOWER CONTACT INTERCONNECTION

INTERCONNECTION: Voltage Regulator – Summing Point

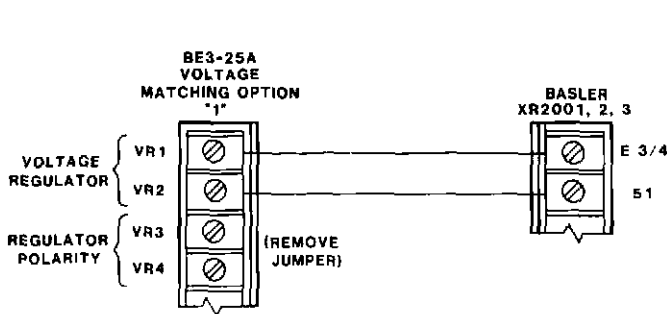

FIGURE 9 – BASLER XR2001, XR2002, XR 2003 INTERCONNECTION

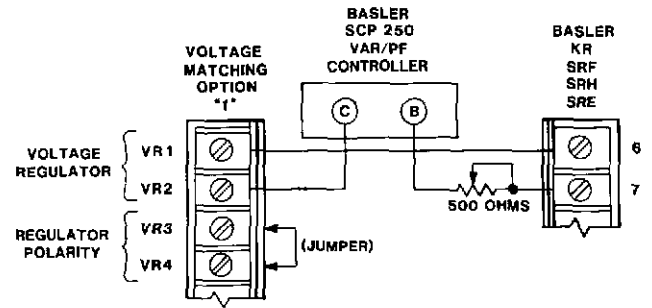

FIGURE 10 – BASLER KR, SRF, SRH, SRE INTERCONNECTION

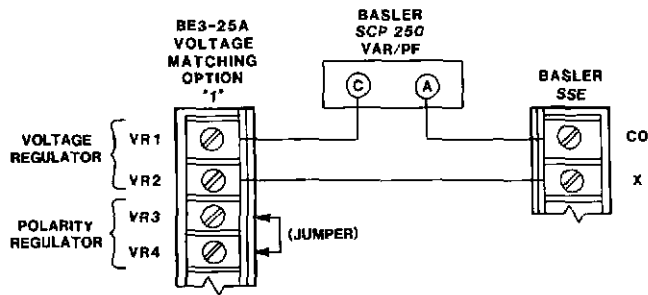

FIGURE 11 – BASLER SSE, SER-CB INTERCONNECTION

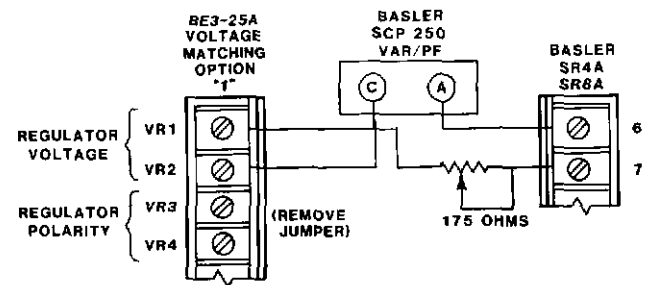

FIGURE 12 – BASLER SRA INTERCONNECTION

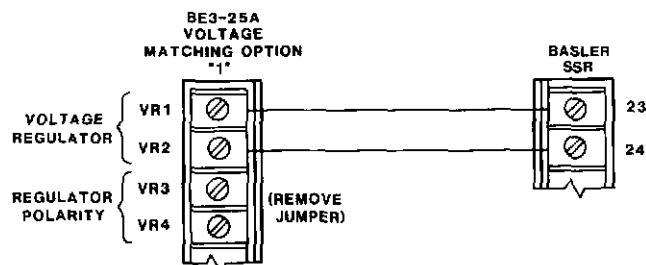

FIGURE 13 – BASLER SSR INTERCONNECTION

**INTERCONNECTION:
Power and Sensing Connections — All Options**

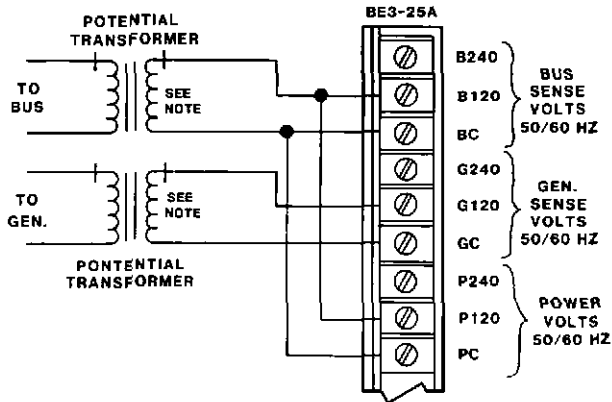

FIGURE 14 -- 120 VAC, POWER FROM BUS

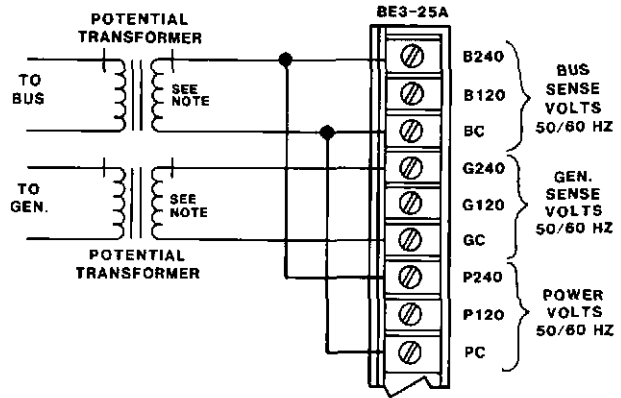

FIGURE 15 -- 240 VAC, POWER FROM BUS

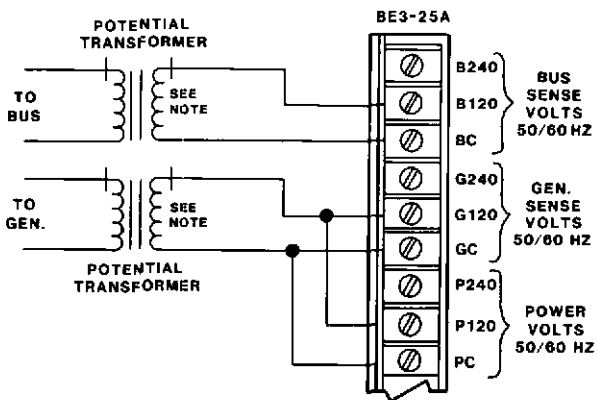

FIGURE 16 -- 120 VAC, POWER FROM GENERATOR

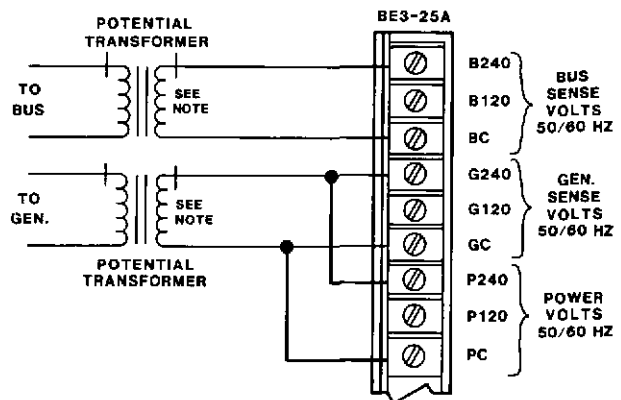
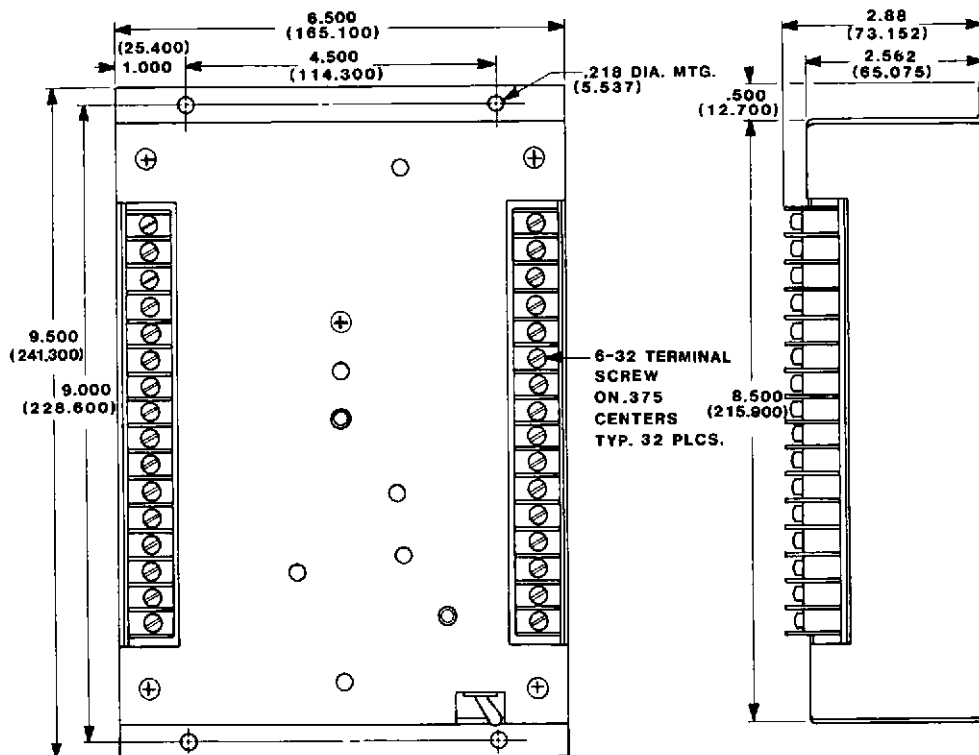
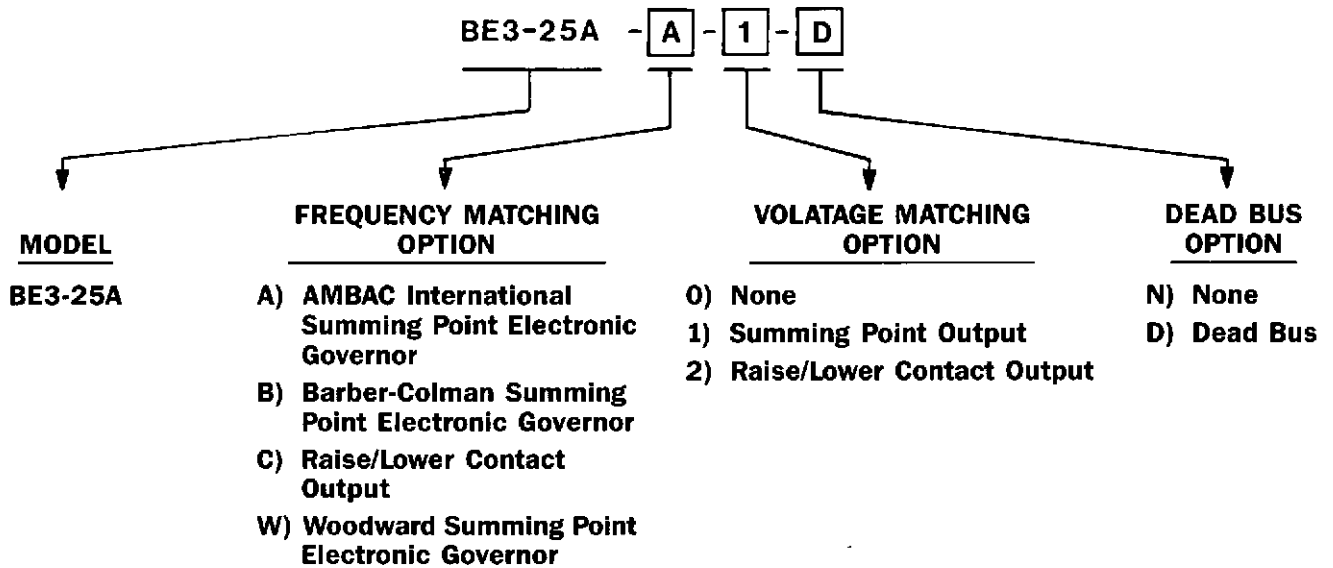

FIGURE 17 -- 240 VAC, POWER FROM GENERATOR

NOTE: THE POTENTIAL TRANSFORMER IS REQUIRED ONLY IF THE BUS/GENERATOR VOLTAGE IS OTHER THAN THAT REQUIRED BY THE BE3-25A FOR SENSING AND INPUT POWER (I.E.: 120 OR 240 VAC)

HOW TO ORDER:

Designate the model number followed by the style number.



NOTE: DIMENSIONS IN PARENTHESES ARE EXPRESSED IN MILLIMETERS.

FIGURE 18 — OUTLINE DRAWING

Basler Electric

BOX 269 HIGHLAND, ILLINOIS 62249, U.S.A. PHONE 618-654-2341 FAX 618-654-2351