

INSTRUCTION MANUAL

FOR

ENGINE/GENERATOR CONTROL

MODEL: ENGEN®-100

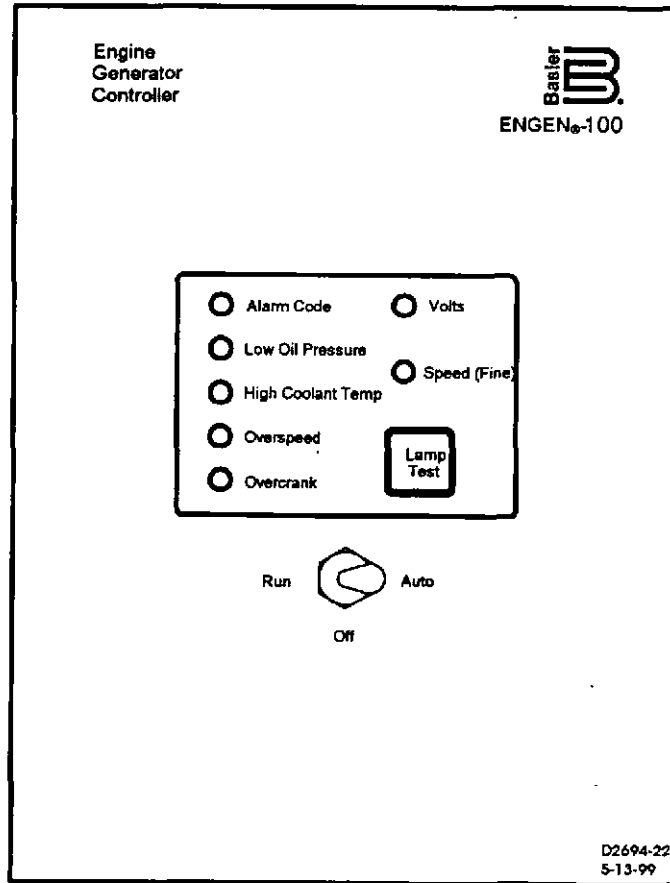

Basler Electric

Publication Number: 9 3296 00 990
Revision : A 07/99

INTRODUCTION

This manual provides information concerning the operation and installation of ENGEN_®-100 Engine/Generator Control. To accomplish this, the following is provided.

- Specifications
- Functional Description
- Mounting Information
- Testing Procedures

WARNING!

To avoid personal injury or equipment damage, only qualified personnel should perform the procedures presented in this manual.

CAUTION

Meggers and high potential test equipment should be used with extreme care. Incorrect use of such equipment could damage components contained in the device.

First Printing: May 1999

Printed in USA

© 1999 Basler Electric Co., Highland, IL 62249

July 1999

CONFIDENTIAL INFORMATION

Of Basler Electric Company, Highland, IL. It is loaned for confidential use, subject to return on request, and with the mutual understanding that it will not be used in any manner detrimental to the interest of Basler Electric Company.

It is not the intention of this manual to cover all details and variations in equipment, nor does this manual provide data for every possible contingency regarding installation or operation. The availability and design of all features and options are subject to modification without notice. Should further information be required, contact Basler Electric Company, Highland, Illinois.



DANGER

In critical applications, use of an over-speed switch with separate solenoid for shutting down the engine is recommended, even though over-speed protection is provided within ENGEN[®]-100.

**BASLER ELECTRIC
ROUTE 143, BOX 269
HIGHLAND, IL 62249 USA**

<http://www.basler.com>, info@basler.com

PHONE 618-654-2341

FAX 618-654-2351

CONTENTS

SECTION 1	GENERAL INFORMATION.....	1-1
	General.....	1-1
	Specifications.....	1-1
	Overexcitation Shutdown.....	1-4
	Accessory Items	1-5
	Power Isolation Transformer.....	1-5
	Manual Voltage Control (MVC 300)	1-5
	Current Boost System (CBS 305)	1-5
SECTION 2	INSTALLATION	2-1
	Mounting	2-1
	Interconnection	2-6
SECTION 3	OPERATION	3-1
	General	3-1
	Preliminary Set-up	3-1
	Run/Off/Auto Switch.....	3-2
	Adjustments	3-2
	Actuator Adjustment.....	3-2
	Magnetic Pick-up Adjustment.....	3-2
	Speed Adjustment.....	3-3
	Stability and Response Adjustment.....	3-3
	Frequency Roll-off Adjustment.....	3-3
	Voltage Regulator Stability Adjustment.....	3-4
	Voltage Adjustment	3-4
	Field Flashing.....	3-4
	System Start-up.....	3-5
	Overexcitation Shutdown.....	3-6
	Operational Test	3-6
SECTION 4	MAINTENANCE	4-1
	Preventative Maintenance	4-1
	Troubleshooting	4-1
	Other LED Fault Indications.....	4-4
	Low Oil Pressure LED	4-4
	High Water Temperature LED.....	4-4
	Overspeed LED.....	4-4
	Overcrank LED.....	4-4
	Replacement Parts	4-5
SECTION 4	MANUAL CHANGE INFORMATION	5-1
	Changes.....	5-1

SECTION 1 • GENERAL INFORMATION

GENERAL

The Basler ENGEN_®-100 engine/generator controller is a non-encapsulated design mounted on a custom aluminum panel. The controller includes a microprocessor-based digital speed governor for the engine and an analog voltage regulator for the generator. The governor controls a linear actuator connected to the fuel control linkage in order to regulate the flow of fuel to the engine. This allows the unit to control engine speed (rpm). The voltage regulator provides excitation for brushless rotary exciter-type generators in order to regulate generator terminal voltage.

Speed regulation is provided by sensing the output of a magnetic speed sensor, converting it to a suitable digital frequency signal, and comparing it to an internal crystal oscillator as a reference. The resulting error signal is used by the microprocessor to control the governor's pulse-width-modulated (PWM) output to the linear actuator to maintain constant engine speed. Full Proportional-Integral-Derivative (PID) control, adjustable to suit the engine time constants for optimum response, is performed by the microprocessor.

Voltage regulation is achieved by detecting the generator's output voltage, converting it to a dc signal, and comparing it to an internal reference in an integrator. The resulting error signal is used to control the regulator's phase-controlled output to the exciter field in order to maintain constant generator voltage.

SPECIFICATIONS

Refer to Tables 1-1 through 1-3 for the electrical specifications and to Table 1-4 for the physical specifications of ENGEN_®-100. Table 1-5 lists the specifications for the linear actuators.

Table 1-1. Electrical Specifications - Voltage Regulator Functions

Output Power (with a 240 Vac Input):	4 Adc @ 63 Vdc (252 W) maximum continuous. 6.66 Adc @ 105 Vdc (700 W) forcing for one minute.
Exciter Field DC Resistance:	15.8 ohms minimum to 100 ohms maximum.
AC Input Power:	190 to 264 Vac, ±10%, single-phase, 50/60 Hz.
Input Burden:	650 VA maximum.
AC Sensing Voltage: 240 Vac Tap: 480 Vac Tap:	190-240 Vac, ±10%, single-phase, 50/60 Hz. 380-480 Vac, ±10%, single-phase, 50/60 Hz.
Sensing Burden:	1 VA maximum.
Voltage Adjust Range:	170 to 264 Vac @ 240 Vac Tap, 340 to 528 Vac @ 480 Vac Tap.
Regulation:	Better than 0.25% no load to full load, average sensing.
Voltage Drift:	Less than 1% for a 40°C (72°F) change.
Response Time:	Less than 1.5 electrical cycles.

Table 1-1. Electrical Specifications (Continued)

Frequency Compensation:	Refer to Figure 1-1.
EMI Suppression:	Internal filtering provided.
Voltage Build-up:	Build-up occurs from generator residual voltage as low as 6 Vac.
Overexcitation Shutdown:	Refer to <i>Overexcitation Shutdown</i> in the following paragraphs.
Power Dissipation:	9 Watts maximum continuous.

Table 1-2. Electrical Specifications - Governor Functions

Output Current:	10 Adc @ 24 Vdc (192 W) maximum continuous.
Actuator Resistance:	Refer to Table 1-5.
DC Input Power:	9 -30 Vdc. (Battery dip ride through to 6V for 0.75 sec)
Speed Signal Input:	250 Hz to 10,000 Hz (16 selectable ranges) from magnetic pick-up.
Speed Adjust Range:	0 to 110% of rated speed (see Calibration Procedure).
Speed Regulation:	± 0.25% (isochronous governing).
Speed Signal Voltage:	40 V rms. maximum continuous, for 15 kohm load. 6 V pk-pk minimum during cranking.
Actuator Failure or Loss of Output Signal:	Engine shutdown occurs if actuator fails or if output signal is lost.
Power Dissipation:	6 W maximum continuous.

Table 1-3. Electrical Specifications - Engine Control

Over-speed shutdown:	Engine shutdown occurs if speed exceeds 125% of the coarse speed setpoint.
Overcrank:	Cranking terminates once the number of selected cranking cycles (1-5) is completed and engine fails to start.
Loss of Speed Signal:	Engine shutdown occurs if speed signal from mag pick-up is lost.
Low Oil Pressure Signal:	Engine shutdown occurs if low oil pressure is detected. A shutdown time delay of 1 second is provided. Upon startup this function is inhibited for 10 seconds.
High Coolant Temp Signal:	Engine shutdown occurs if high coolant temperature is detected. A shutdown time delay of 1 second is provided. Upon startup this function is inhibited for 10 seconds.
Common Alarm Input	Engine shutdown occurs if a contact closure is detected across these terminals.
Common Alarm Output	A closure of this contact indicates that the engine shutdown has occurred. This contact is rated at 10A (10 Vdc or 277 Vac).
Crank/Rest Time:	Adjustable to give the desired cranking/rest times from 2 to 30 sec +20%.
Engine Crank Time Delay:	0 to 60 seconds

Table 1-4. ENGEN[®]-100 Environmental and Physical Specifications

Operating Temperature:	-40°C (-40°F) to +60°C (+140°F).
Storage Temperature:	-40°C (-40°F) to +85°C (+185°F).
Shock:	Withstands up to 15 G's in each of three mutually perpendicular axes.
Vibration:	Withstands the following accelerations at the stated frequency: 1.2 G's at 5 to 26 Hz, 0.036 inches double amplitude at 27 to 52 Hz, 5.0 G's at 53 to 500 Hz.
Weight:	3 lbs. (1.4 kg.)

Table 1-5. Linear Actuator Specifications (Optional - Shipped Separately)

Parameter	Model 0175*	Model 0250*	Model 0300*
Coil Resistance	2.67 ohms nom. (12 Vdc)	1.76 ohms nom. (12 Vdc)	1.69 ohms nom. (12 Vdc)
	12 ohms nom. (24 Vdc)	6.85 ohms nom. (24 Vdc)	7.05 ohms nom. (24 Vdc)
Stroke	0.8 inches (max.)	1.0 inches (max.)	1.0 inches (max.)
Net Force	4.0 pounds	6.0 pounds	15.0 pounds
Spring Shutdown Force @ Full Stroke	0.5 pounds	1.7 pounds	4.5 pounds
Work Ratings	0.3 ft-lbs.	0.7 ft-lbs.	1.3 ft-lbs.
Voltage	12 or 24 Vdc ± 20% (different actuators required)		
Current	4.5 amps (12 Vdc), 2.0 amps (24 Vdc)	6.8 amps (12 Vdc), 3.5 amps (24 Vdc)	7.1 amps (12 Vdc), 3.4 amps (24 Vdc)
Response Time	30 ms for 10-90% of stroke	65 ms for 10-90% of stroke	80 ms for 10-90% of stroke
Shipping Weight	1.5 lbs. (0.7 kg.)	3.0 lbs. (1.4 kg.)	6.5 lbs. (3.0 kg.)
Temperature Range	-40°C (-40°F) to +121°C (+250°F)		
Vibration	15 G's		
Shock	200 G's		

* Available in push or pull, base or flange type mount actuators. Refer to Figures 2-3, 2-4, and 2-5.

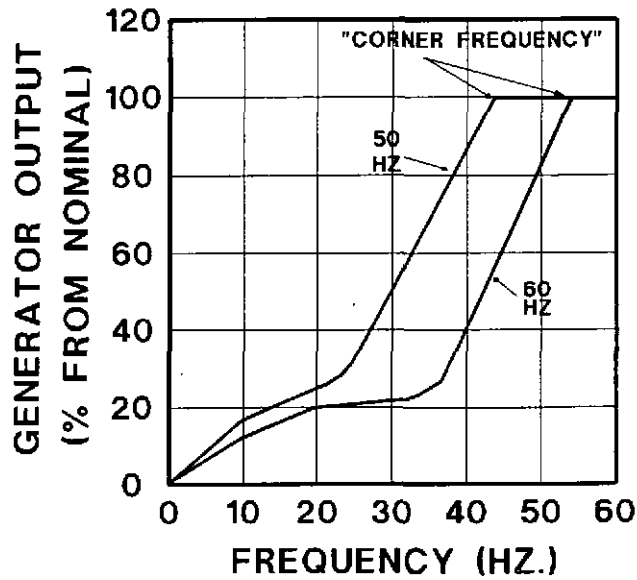

Figure 1-1. Typical Frequency Compensation Curves

OVEREXCITATION SHUTDOWN

Refer to Figure 1-2. If the exciter field voltage exceeds 100 ± 5 Vdc, the regulator automatically removes the field current after a time delay. The time delay is inversely proportional to the magnitude of the detected overvoltage condition. At approximately 135 ± 5 Vdc, the field voltage is removed instantaneously.

On detection of overexcitation and the resulting field voltage shutdown, the regulator will not reset or return to an operational condition until the generator output drops to less than 6 Vac for ten seconds minimum.

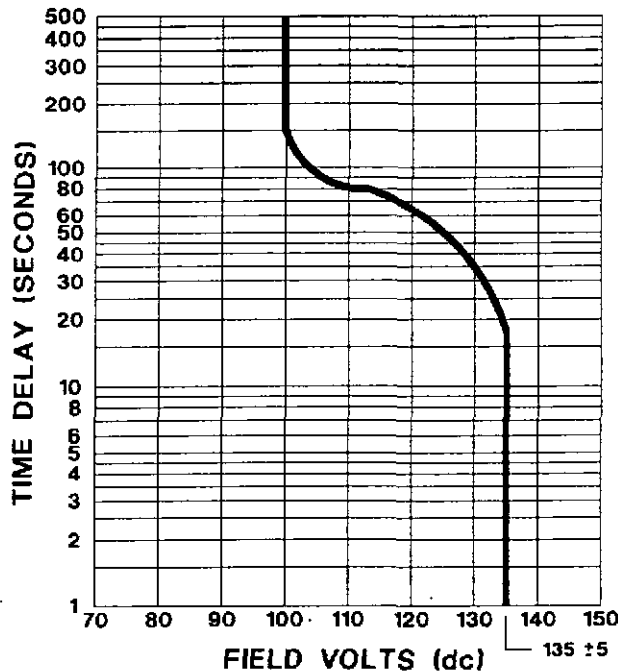

Figure 1-2. Typical Inverse Time Delay Characteristic Curves

ACCESSORY ITEMS

Power Isolation Transformer

A low voltage power isolation transformer can be used to provide electrical isolation and to match voltages from the generator to the regulator. To obtain maximum regulator output power (exciter field resistance of 15 to 100 W), use power isolation transformer BE 18674.

Manual Voltage Control (MVC 300)

This control offers back-up excitation for the regulator in critical applications. The regulated output of this electronic manual control improves the performance of a generator using traditional types of manual control.

Current Boost System (CBS 305)

Using a current transformer with its primary fed from the generator's line current, the CBS 305 boosts the field current during short circuit or large motor starting to maintain output current.

SECTION 2 • INSTALLATION

MOUNTING

The unit is intended for through-the-panel mounting. Refer to the physical outline (Figure 2-1) and the recommended mounting hole pattern (Figure 2-2). It may be mounted directly on the generator set using #10 hardware. Select the proper hardware to withstand any expected shipping/transportation and operating conditions.

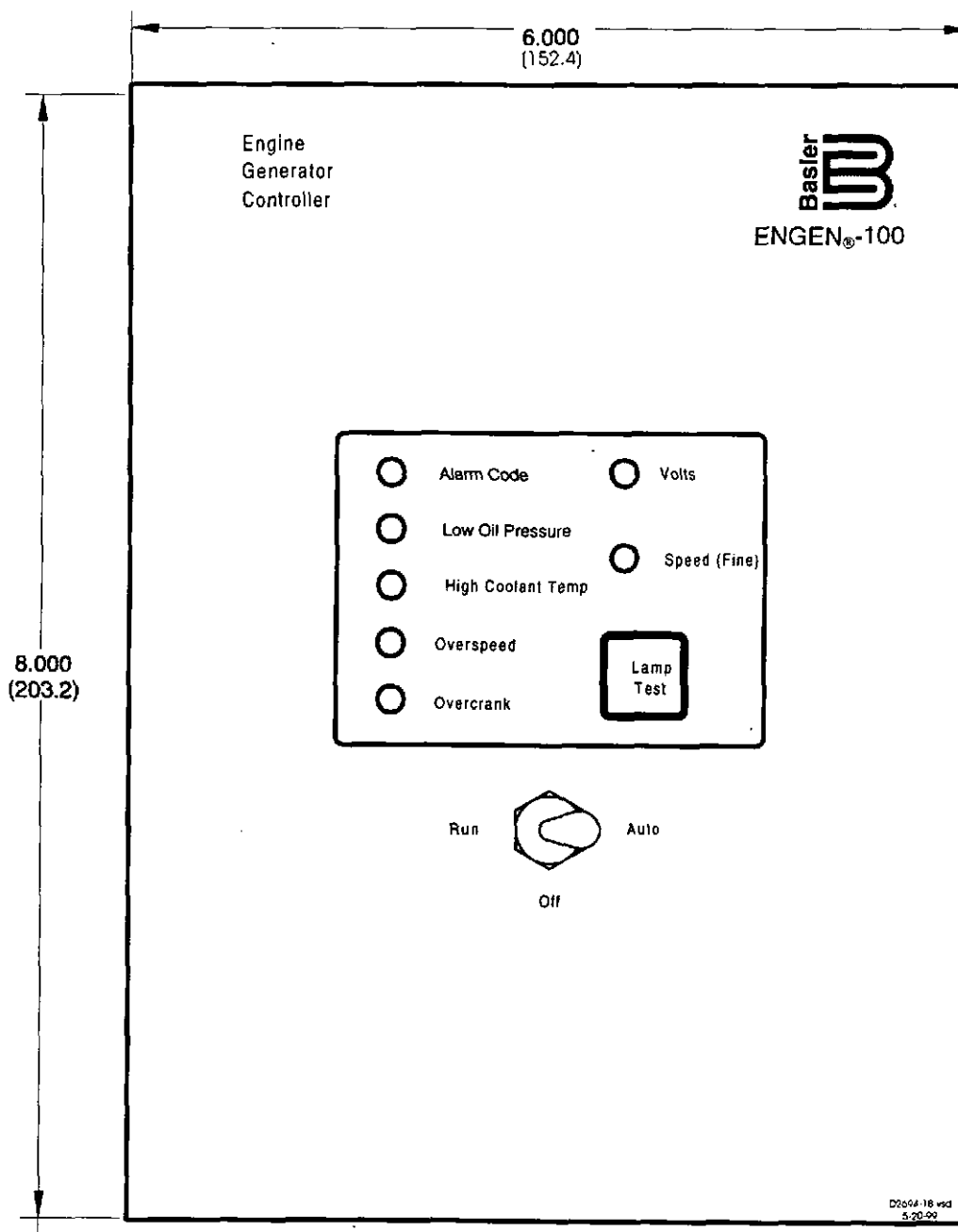

Figure 2-1 ENGEN®-100 Physical Outline

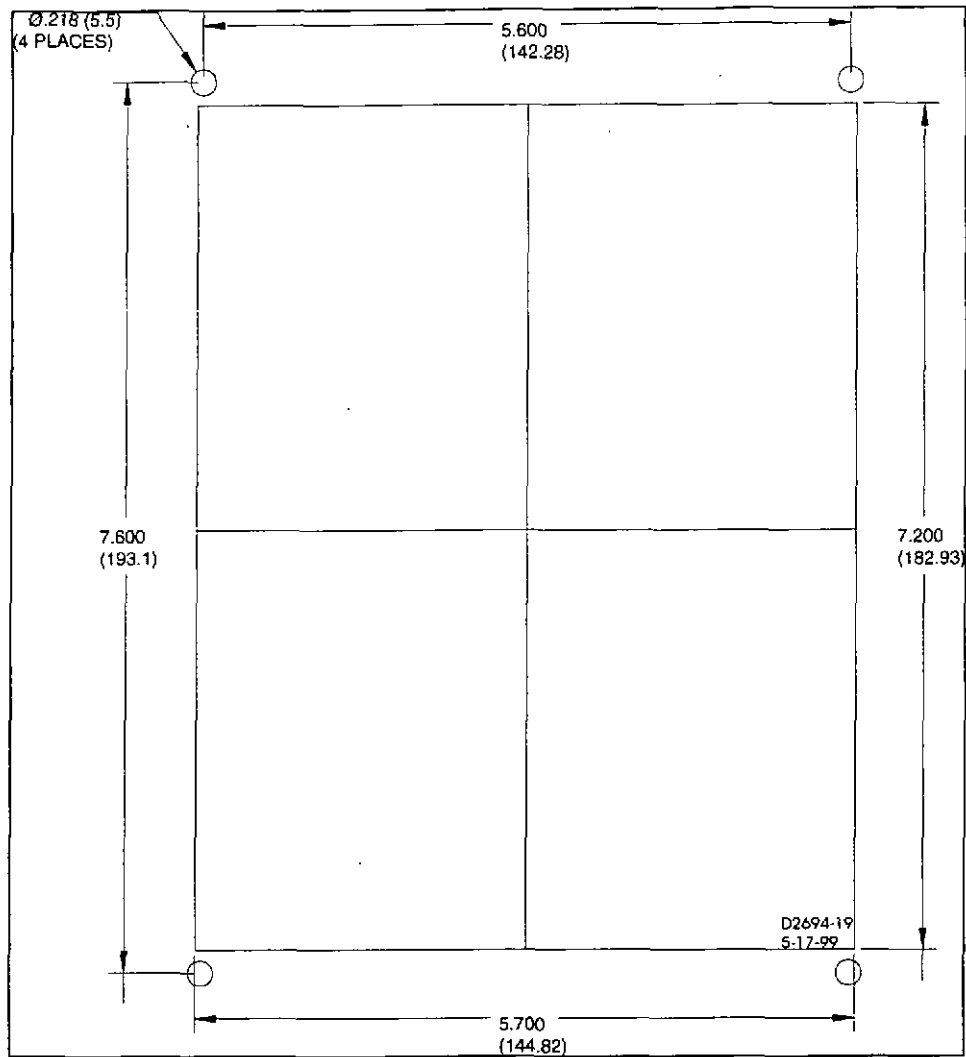
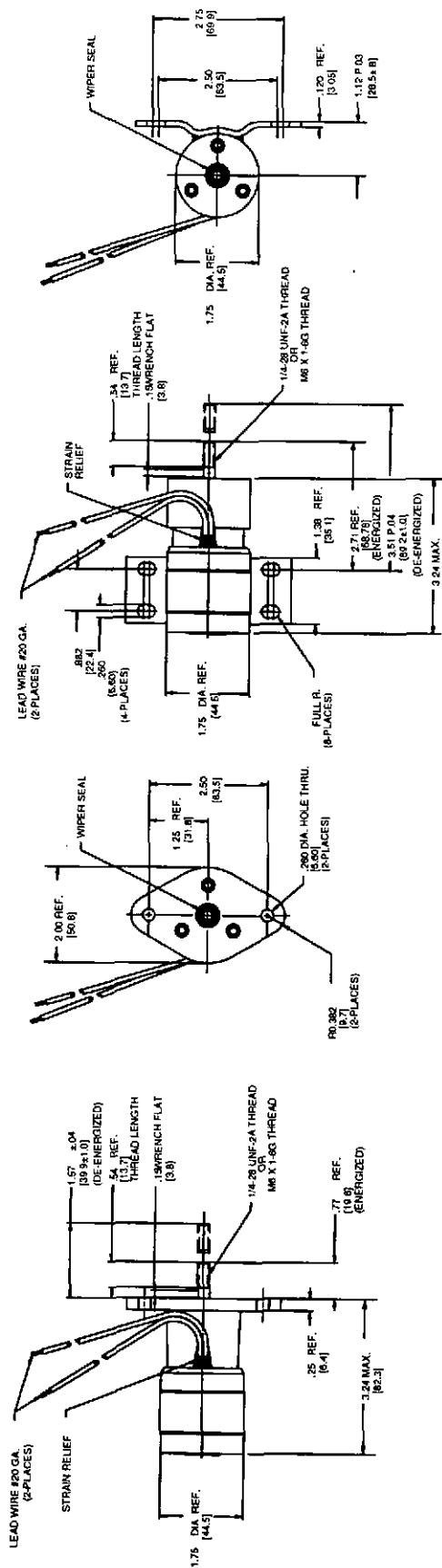

Figure 2-2. Recommended Mounting Hole Pattern

NOTES:

1. Mount the unit in a location where the effects of vibration and temperature are within the specified range.
2. Ensure the magnetic pick-up is fitted according to the manufacturer's specifications and is neither touching the flywheel nor too far away from the teeth to give an adequate speed signal.
3. Ensure the actuator is fitted correctly and rigidly according to specifications and the linkage is adjusted correctly without friction or free play. (See Section 3, *Adjustments*, for details.)



0175 PROPORTIONAL ACTUATOR PULL/FLANGE

0175 PROPORTIONAL ACTUATOR PULL/BASE

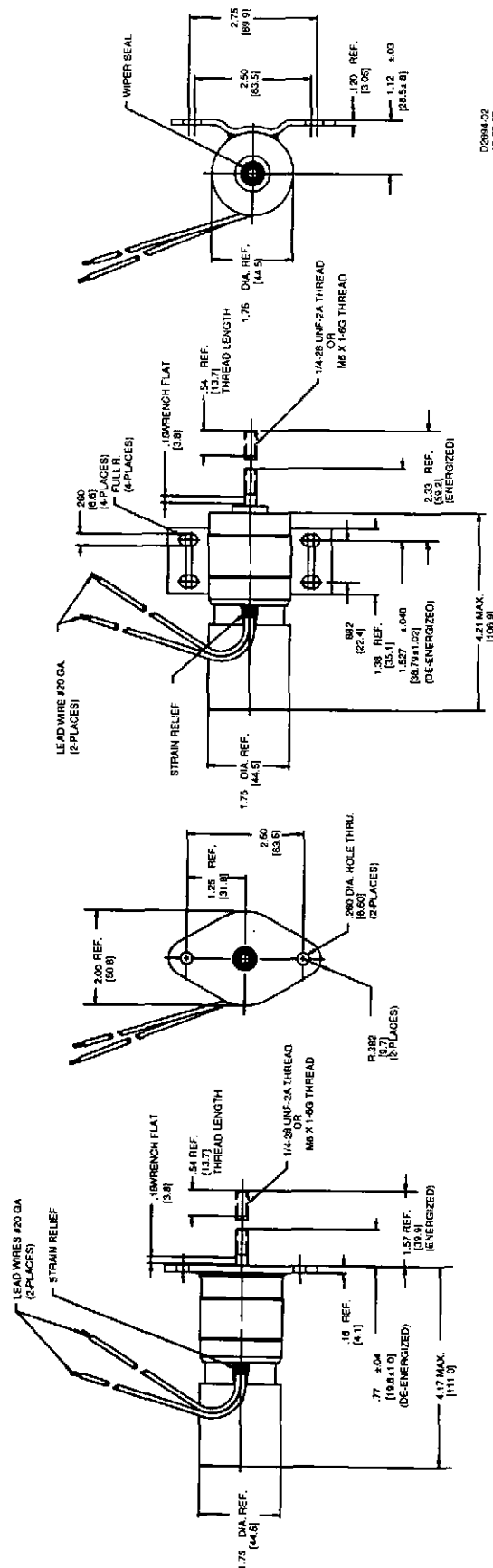

0175 PROPORTIONAL ACTUATOR PUSH/FLANGE

0175 PROPORTIONAL ACTUATOR PUSH/BASE

D2884-02
10-23-87

Figure 2-3. 0175 Proportional Actuator Outline Drawing

INTERCONNECTION (Refer to Figures 2-6 through 2-10.)

- a. Current Boost System Interconnection: Switch number 2, of the 50/60 Hz switch, should be off to enable CBS control, (or remove the jumper across **CB+/-**). Connect terminals **CB-** and **CB+** to the **CBS 305** inputs. If the **CBS 305** is not being used, leave the switch (**Position 2**) "ON" or the jumper in place. Refer to Figure 2-10.
- b. Connect the exciter field to terminals **F+** and **F-**. **Be sure to observe polarity.**
- c. Connect the input power to the generator stator to provide the proper (**240 Vac nominal**) power to terminals **3** and **4**. Fuse both leads. Install the optional shutdown switch in series with the wires to terminal **3** and/or **4** if desired.
- d. Connect the sensing input to either **240** or **480** depending on voltage. (The sensing can be connected "line-to-line" or "line-to-neutral".)
- e. Connect (12 or 24 Vdc) to the **Battery +** and **-** terminals with adequately sized cable. (See 'g' below). **Reverse connection will cause the fuse to blow.**
- f. The actuator must be rigidly mounted on two axes with respect to the engine's frame: ¼" cold rolled steel is recommended for the mounting bracket. Connect the linear actuator to the engine's fuel control linkage so as to obtain the desired range of throttle motion over the actuator's length of travel. There should be no free play or friction points in the linkages or actuator; heavy duty spherical rod ends are recommended for the linkage. Check manually that the actuator allows the linkage to return to the engine shutdown fuel position when fully de-energized, and can reach the required maximum fuel position without exceeding the specified stroke.
- g. Connect the actuator leads to the **Actuator** terminals. Do not use wire which is too small for the actuator current for a given distance from the ENGEN_®-100 controller. This current also flows through the battery supply leads, so include the length of these in the calculation of overall length. The following table gives the maximum total length (both directions) of connecting wire for a 5% reduction on available force at room temperature.

Table 2-2 Connecting wire length for a 5% reduction in available force at room temp

ACTUATOR	AWG14(1.5 mm ²)	AWG16(1.0 mm ²)	AWG18(0.75 mm ²)
0175	66 ft (20 m)	33 ft (10 m)	22 ft (6.7 m)
0250	46 ft (14 m)	23 ft (7 m)	15 ft (4.6 m)
0300	46 ft (14 m)	23 ft (7 m)	15 ft (4.6 m)

- h. Using a **shielded, twisted-pair** cable, connect the magnetic pick-up to the **Speed Signal +** and **COM** terminals. Connect the **shield** wire to the 'quick connect' terminal under the end cover's mounting screw closest to the speed signal terminals.
- i. Connect one lead of the coil of the starter motor's cranking solenoid in series with the engine battery. Connect this circuit across the **Crank Relay** terminals.
- j. Connect one lead of the coil of the engine's fuel valve solenoid to the engine battery. Connect this circuit across the **Fuel Valve Solenoid** terminals.
- k. For systems using glow plugs, the **Glow Plug** terminals should be connected such that they control a customer supplied interposing relay that applies power to the glow plugs of the diesel engine. The glow plug contacts, which are normally open will close at the beginning of the crank delay period. *They will open once the crank disconnect speed is reached.*
- l. Connect the low oil pressure sending contact to the '**Oil Pres**' terminal. If the contact is a 2-wire sending unit, tie the second wire directly to the engine frame. (This assumes a negative grounded system.) Select the NO or NC switch position on System Configuration switch (Position 2) to suit the type of oil pressure sender used. Refer to Figure 2-10.
- m. Connect the high coolant temperature sending contact to the '**Coolant Temp**' terminal. If the contact is a 2-wire sending unit, connect the second wire directly to the engine frame. (This assumes a negative grounded system.) Select the NO or NC switch position on System Configuration switch (Position 1), refer to Figure 2-10, to suit the type of temperature sender used.

- n. If the engine needs to be shut down from a remote location, then connect a normally open contact to the **Common Alarm In** terminals. The contact closing from either a common alarm or a remote switch will shut down the engine and light the 'Alarm' LED on the ENGEN_g-100 front panel. Note that once a common alarm is initiated, power must be cycled to reset the alarm condition.
- o. If the engine needs to be started from a remote location, then connect a normally open remote starting contact or automatic transfer switch contact to the **ATS** terminals. The contact closing will initiate engine starting, (this is a "maintained" contact) with the Run/Off/Auto switch in the 'Auto' position.
- p. If remote annunciation is desired, the **Common Alarm Output** contact may be used to indicate engine shutdown. This contact, which is normally open, closes whenever the engine is shut down due to an alarm condition. The contact will remain closed until the Run/off/Auto switch is placed in the 'Off' position.
- q. Connect the **Chassis Gnd** terminal to a proper frame ground as close to the unit as possible.

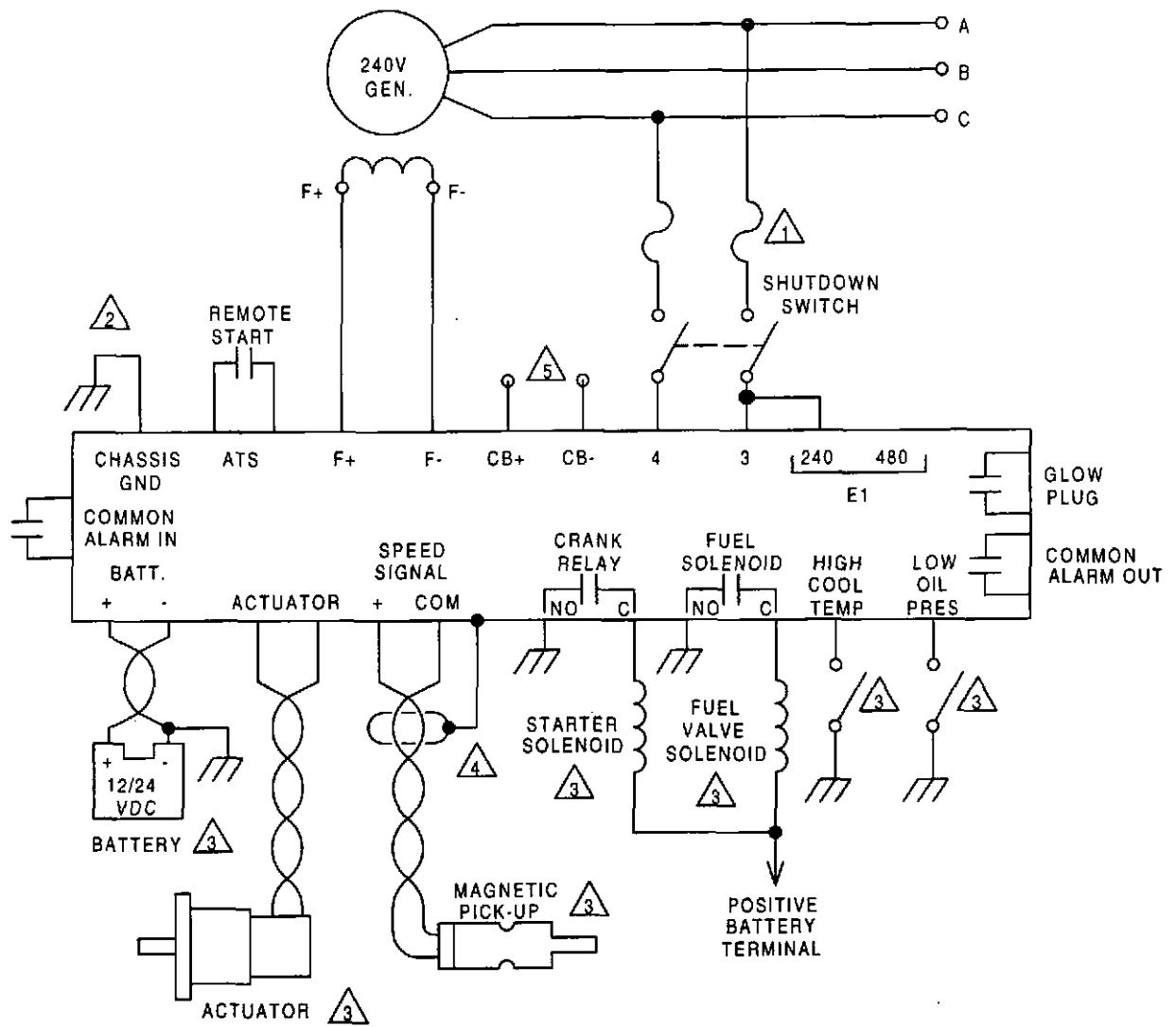

- 1 300V, 5A, FAST BLOWING, HIGH INTERRUPTING CAPACITY FUSES.
- 2 GROUND THE UNIT TO THE ENGINE FRAME.
- 3 THIS ITEM LOCATED ON THE ENGINE-GENERATOR SET.
- 4 CONNECT SHIELD WIRE TO FASTON ON UNIT'S END PLATE.
- 5 REFER TO FIGURE 2-10 AND CBS 305 INSTRUCTION MANUAL FOR PROPER INTERCONNECTION (IF USED).

D2694-13
5-12-99

Figure 2-6. 240 Vac, Single-Phase, Interconnection Diagram

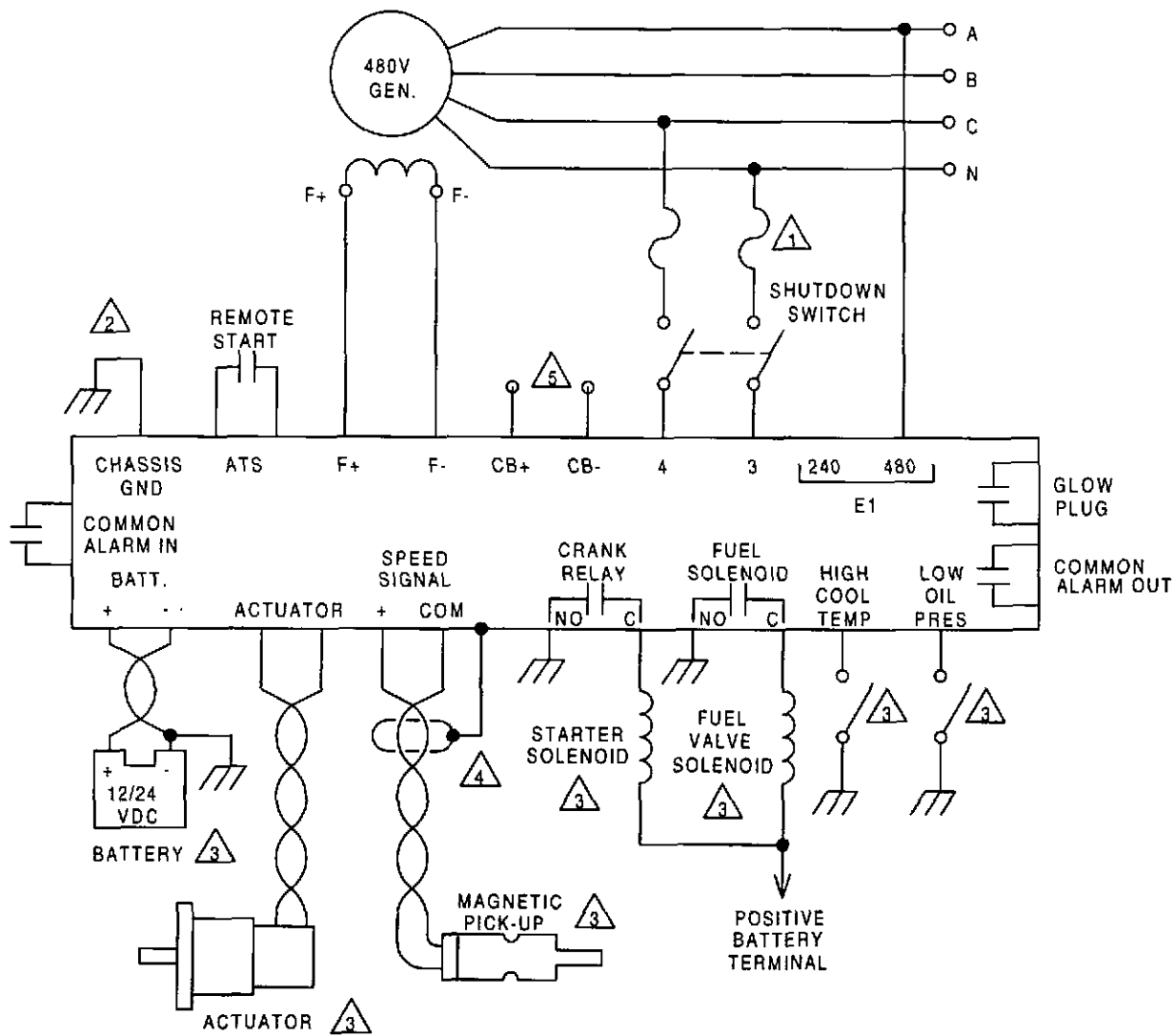

- ⚠ 1 300V, 5A, FAST BLOWING, HIGH INTERRUPTING CAPACITY FUSES.
- ⚠ 2 GROUND THE UNIT TO THE ENGINE FRAME.
- ⚠ 3 THIS ITEM LOCATED ON THE ENGINE-GENERATOR SET.
- ⚠ 4 CONNECT SHIELD WIRE TO FASTON ON UNIT'S END PLATE.
- ⚠ 5 REFER TO FIGURE 2-10 AND CBS 305 INSTRUCTION MANUAL FOR PROPER INTERCONNECTION (IF USED).

D2694-14
5-12-99

Figure 2-7. 480 Vac Interconnection Diagram

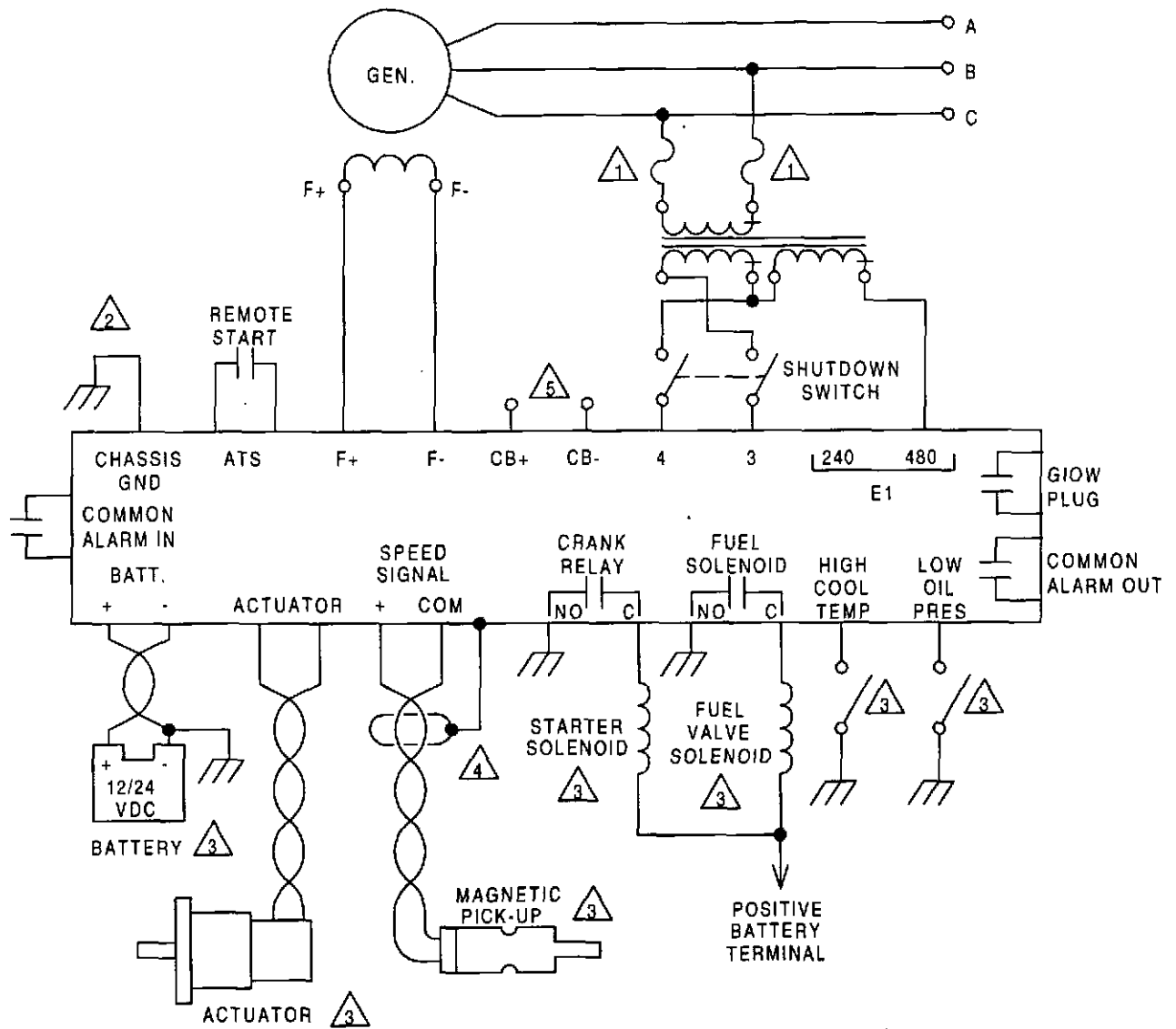

- 1 FUSE SHOULD BE SELECTED TO ADEQUATELY PROTECT THE TRANSFORMER/AVR.
- 2 GROUND THE UNIT TO THE ENGINE FRAME.
- 3 THIS ITEM LOCATED ON THE ENGINE-GENERATOR SET.
- 4 CONNECT SHIELD WIRE TO FASTON ON UNIT'S END PLATE.
- 5 REFER TO FIGURE 2-10 AND CBS 305 INSTRUCTION MANUAL FOR PROPER INTERCONNECTION (IF USED).

D2694-15
5-12-99

Figure 2-8. Isolation Transformer Interconnection Diagram

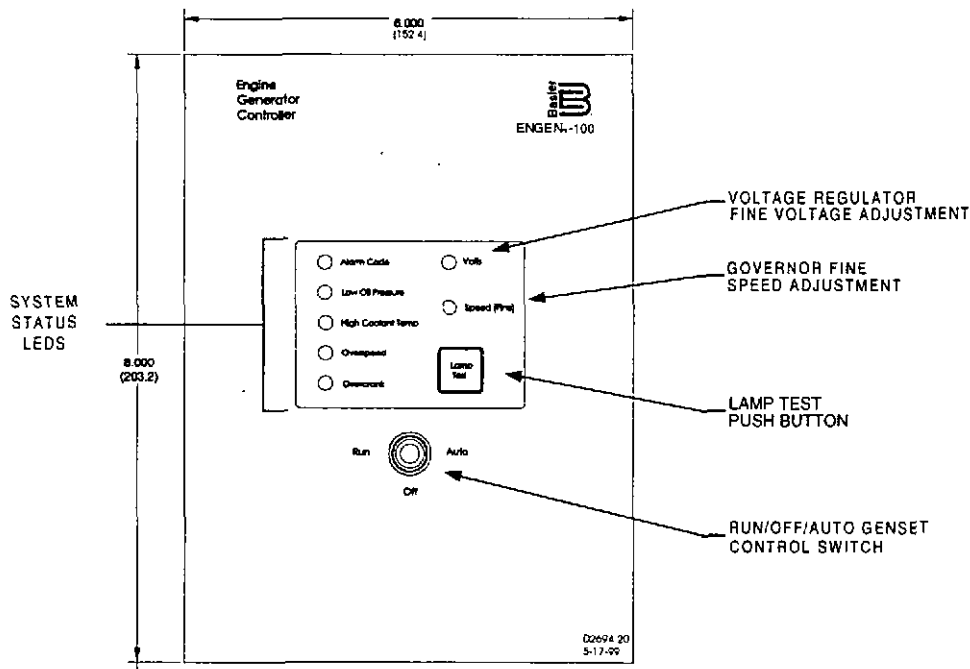

Notes:
1. ALL DIMENSIONS ARE IN INCHES. DIMENSIONS IN PARENTHESIS ARE IN MILLIMETERS.

Figure 2-9. Engine/Generator Controller Adjustments Diagram (Front View)

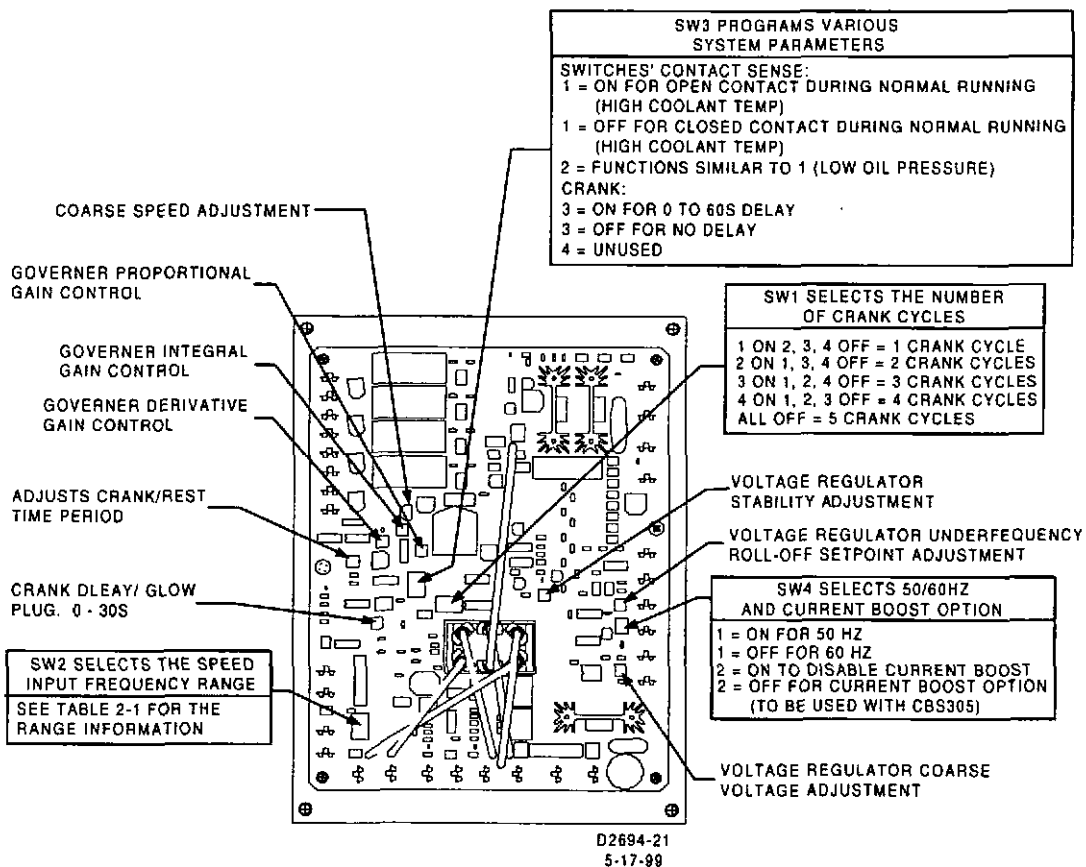

Figure 2-10. Engine/Generator Controller Adjustments (Top View)

Table 2-2. Range Information for Switch 2 (Speed Input Frequency Range)

Hz	Switch No. 1	Switch No. 2	Switch No. 3	Switch No. 4
200-650	ON	ON	ON	ON
400-1300	OFF	ON	ON	ON
600-1950	ON	OFF	ON	ON
800-2600	OFF	OFF	ON	ON
1000-3250	ON	ON	OFF	ON
1200-3900	OFF	ON	OFF	ON
1400-4550	ON	OFF	OFF	ON
1600-5200	OFF	OFF	OFF	ON
1800-5850	ON	ON	ON	OFF
2000-6500	OFF	ON	ON	OFF
2200-7150	ON	OFF	ON	OFF
2400-7800	OFF	OFF	ON	OFF
2600-8450	ON	ON	OFF	OFF
2800-9100	OFF	ON	OFF	OFF
3000-9750	ON	OFF	OFF	OFF
3200-10400	OFF	OFF	OFF	OFF

SECTION 3 • OPERATION

GENERAL

Perform the following procedures to set up, start, operate, and adjust the ENGEN[®]-100. Symptoms and possible solutions for incorrect regulator or governor adjustment other GENERATOR system problems are included in Table 3-1.

PRELIMINARY SET-UP

To prevent damage to the regulator, generator or engine, complete the following steps before proceeding with system start-up:

1. Verify that the voltage regulator specifications conform with the generator requirements and that the governor specifications conform with the engine/actuator requirements. Adjust the coarse Volts set pot to minimum (fully counter-clockwise).
2. Ensure that the controller has been installed and connected in accordance with Section 2.
3. Configure the **50/60 Hz** frequency switch (Position 1) for the correct operation frequency. 'OFF' for 60 Hz operation, 'ON' for 50 Hz.
4. Configure the **SPEED INPUT FREQUENCY** selection switches to the correct input frequency from the magnetic probe, as follows:-
 - a. Ascertain the number of teeth (N) on the flywheel ring gear and use this figure to calculate the probe frequency (F) in Hertz (Hz) from the desired engine speed (RPM) using following formula:

$$F = \frac{N \times \text{R.P.M}}{60}$$

(EXAMPLE: for an engine with 129 teeth running at 1800 RPM, F will be 3870 Hz.)

- b. From the table shown in Figure 2-10, select the correct combination of **SPEED INPUT FREQUENCY** switches to suit the input frequency derived from the formula above.
5. Configure the **CRANK CYCLES** switch from the table shown in Figure 2-10, to get the desired number of crank and rest cycles, from 1 to 5.
 6. Adjust the **CRANK TIME** trimmer to give the desired length of cranking and rest times (Fully counter-clockwise is 2 sec's, fully clockwise is approximately 30 seconds; the crank and rest times are approximately equal for a given setting).
 7. If the crank delay switch is in the on position, adjust the **CRANK DELAY** trimmer to give the desired length of crank delay. (Fully counter-clockwise is approximately 0 seconds, fully clockwise is approximately 60 seconds.) For systems using the glow pug output contact, glow plugs will be enabled from the start of the crank delay period until crank disconnect speed is reached.



DANGER

During calibration, be prepared to manually shut down the engine. In critical applications, use of an overspeed switch with separate solenoid for shutting down the engine is recommended, even though overspeed protection is provided within ENGEN[®]-100

RUN/OFF/AUTO SWITCH

WARNING!

During periods of prime mover idling, it is desirable to use the shutdown switch to remove power from the regulator.

The RUN/OFF/AUTO switch controls the status of the generator set. In the "OFF" position the genset will not start and all power is removed from the internal circuitry of the ENGEN₆-100 unit. In this position the lamp test push button will not operate. In the "RUN" position the genset will start and the ENGEN₆-100 unit will control frequency and voltage control and shutdown protection. The genset will remain operating until the switch is placed in the "OFF" position or until a fault occurs. In the "AUTO" mode the ENGEN₆-100 unit monitors the ATS input for a contact closure. Upon receiving a closed contact, the ENGEN₆-100 unit will start and control and protect the genset. The genset will remain operating until the contact, on the ATS input, opens or until the RUN/OFF/AUTO switch is placed in the "OFF" position.

ADJUSTMENTS

Actuator Adjustment

1. Adjust linkage to position fuel control lever to shutdown engine with actuator control shaft fully de-energized.
2. Manually move linkage from shutdown to maximum fuel, ensuring actuator will return linkage to shutdown position and full travel of linkage is smooth and uninhibited, and does not exceed specified stroke.
3. Tighten all nuts and bolts of the linkage and actuator mounting flange. Repeat previous steps to ensure desired operation.
4. Use a tachometer or frequency meter connected to the signal source to measure engine speed.
5. Start the engine.
6. Manually move the linkage from shutdown to maximum fuel position.
7. Adjust linkage until speed of the engine does not change.
8. Release actuator and ensure linkage is returned to the shutdown position.
9. The return spring should return to the minimum fuel position, and shut down the engine. Repeat the previous steps to ensure desired operation.

NOTE

On engines with mechanical governors, the mechanical governor should be adjusted 5-10% above the desired operating speed at no-load conditions. This will prevent undesired interaction between the mechanical and electronic governors.

Magnetic Pick-up Adjustment

1. The mounting of the pick up unit must be rigid: excessive vibration relative to the sensed gear causes spurious signals and may cause unacceptable performance of the system.
2. Airgap between the pick-up and the sensed gear must be sufficient to prevent pole piece damage. Gear tooth run-out (eccentricity) and bearing wear must be considered. The gap should be as small as practicable to obtain a reliable high level signal at low speed. From time to time the pole piece should be cleaned of any magnetic filings which it may attract to ensure reliable operation.
3. Generally a gap of 0.015" to 0.025" is satisfactory. If the gap cannot be measured directly, center one tooth immediately under the center pole of the pick-up, and turn the pick-up clockwise into its mounting until it just touches the tooth. Turn the pick-up counter-clockwise by 95° to 180° to obtain a

gap of 0.015" to 0.025". It is imperative that the pick-up be installed at the correct gap and mounting orientation. Lock the pick-up firmly in this position using the locking nut.

4. Use proper mating connectors and/or twisted-pair shielded cable as specified.

Speed Adjustment

The ENGEN_e-100 has an overspeed shutdown feature which activates whenever the engine speed reaches 125% of the coarse speed setpoint. Using the fine speed trimmer, it is possible to set the overspeed shutdown setpoint within a range from 105% to 125% of the desired set point. Adjustment proceeds as follows:

Set the FINE speed trimmer to the counter-clockwise position. Adjust the COARSE speed trimmer to minimum (fully counter-clockwise) when starting for the first time, then to 80% of the desired overspeed shut down setpoint. The FINE speed adjustment, on the front panel, will then allow trimming to the desired operating speed. Setting the coarse adjustment to minimum may induce an overspeed fault during cranking. If this occurs, cycle power to ENGEN_e-100 and increase the coarse adjustment 2-3 turns and restart.

Stability and Response Adjustment

The governor has the ability to adjust the Proportional-Integral-Derivative (PID) terms of the feedback control loop. Before starting, adjust the proportional gain to the mid-position and the integral and derivative trimmers to the fully counter-clockwise position. When the engine has been started, adjust these for optimum performance using an oscilloscope or chart recorder, connected to the generator's output terminals, in the following steps:-

1. Start the engine with no load, and trim the speed to the desired value.
2. Proportional gain is used to improve response time; a maximum amount of proportional gain should be used while maintaining stability. Increase proportional gain until the speed just starts to oscillate, then decrease until the oscillation stops. If oscillation does not occur even at maximum setting, bump the actuator lever then decrease proportional gain until the oscillation stops.
3. Integral gain is used to remove steady state errors. Increase integral gain until oscillation just starts, then decrease until oscillation stops. If oscillations do not occur, bump the actuator lever as before then decrease integral gain until oscillation stops.
4. Derivative gain is used to improve stability. Increase derivative gain until response has a slight overshoot on load transients. If derivative gain is too high, response will be slow when a load is applied or removed. If too low, response will be undamped with a large overshoot, and settling time may be too long. Note that a small amount of short term fluctuation is normal in any closed loop control system such as this, and is due in part to engine tuning, fuel flow, electrical noise and the sampled nature of the digital control.
5. Apply a variety of loads up to 100% on and off to check performance and stability, repeating steps 2, 3, and 4 until response has a fast recovery with minimum overshoot and low settling time.
6. Test for overshoot by turning the controller off, letting speed drop to about 50%, then turning the controller back on. If the overshoot exceeds 4%, decrease integral gain slightly and repeat this test.
7. Test for cold start stability with the engine cold. If the speed oscillates, decrease proportional and integral gains slightly until the oscillation stops.

Frequency Roll-Off Adjustment

The ENGEN_e-100 underfrequency adjust is factory preset to cause an average 2 V drop in the generator's line input voltage to the regulator when the frequency is between 54.5 and 55.5 Hz (for 60 Hz applications). For 50 Hz applications, the frequency "roll-off" is factory preset to between 44 and 46 Hz. To reset the frequency roll-off, proceed as follows:

1. Adjust the prime mover RPM to the desired frequency compensation (corner frequency roll-off) point. (Refer to Figure 1-1.)

2. Adjust the front panel **FREQ.** control until the generator voltage starts to drop off by about 1V.
3. Bring the prime mover up to rated speed. The output voltage should return to normal.

Voltage Regulator Stability Adjustment

An oscilloscope or other voltage recording device should be used if a stability setting is desired that will provide the fastest possible voltage response with good generator stability.

1. Rotation of the front panel **STAB** control in the clockwise (CW) direction will slow response time.
2. Rotation of the front panel **STAB** control in the counter-clockwise (CCW) direction will speed response time. If rotated too far CCW, the generator voltage may oscillate (hunt).
3. Rotate the front panel **STAB** control CCW until the system starts oscillating and then rotate CW just past the point where oscillation occurred.

Voltage Adjustment

Set the **FINE** voltage adjust trimmer to its center position. Adjust the **COARSE** volts adjust pot to the desired voltage. The **FINE** control will then allow $\pm 10\%$ adjustment from the front panel.

Field Flashing

When the regulator is operated with the generator for the first time, the polarity of the residual magnetism may not be correct or of sufficient magnitude. If the residual voltage at terminals 3 and 4 is greater than 6 Vac and the field polarity is correct, replace the regulator. If generator residual voltage is less than 6 Vac at terminals 3 and 4, shut down the prime mover and proceed with the following steps:

CAUTION

Do not flash the field with the regulator connected or with the generator in motion. The regulator may be damaged.

1. Remove the connections to F+ and F- on the regulator. With the prime mover at rest, apply a dc source (ungrounded), of not more than 48 Vdc, to field terminals F+ (positive) and F- (negative) in series with a limiting resistor. Use one (1) ohm of resistance for each volt from the dc power source with a power rating of least one (1) watt per ohm.

(EXAMPLE: If using a 24 Vdc source, use a 24 ohm, 24 watt resistor.)

2. Allow the field to be flashed for approximately ten seconds before removing the dc source.
3. Reconnect the regulator; if voltage build-up does not occur after performing steps (1) and (2), verify the polarity of the dc source used in steps (1) and (2) and repeat the operation.

SYSTEM START-UP

Refer to Table 3-1 for starting up the system.

Table 3-1. System Start-up

Procedure	Symptom	Remedy
1. Perform the preliminary adjustments and the set-up procedure.	N/A	N/A
2. Start prime mover and bring up to rated speed.	a. Voltage does not build-up.	a. Flash field. b. Troubleshoot (See Section 4).
	b. Voltage builds up and then decays.	Troubleshoot.
3. Slowly adjust fine & coarse VOLT adjustment until voltage reaches nominal.	a. Voltage does not build up to rated value.	a. Check generator output for shorted or excessive load. b. Troubleshoot.
	b. Voltage high and uncontrollable.	Troubleshoot.
4. Apply and remove load to check stability.	Generator voltage response too slow or is hunting (oscillating).	a. Check for excessive load on generator; adjust stability as necessary. b. Troubleshoot.
5. Check regulation under normal operating conditions.	Poor regulation.	a. Check that prime mover is up to speed & for excessive load on generator. b. Check that voltmeter is connected at the same point as the regulator sensing. c. Use an average sensing voltmeter (not an RMS sensing instrument). d. Troubleshoot.
6. Reduce generator frequency to approximately 5 Hz below nominal. Generator output should decrease from this point.	Generator output voltage does not decrease at desired frequency.	a. Check that all wiring is in accordance with section 2. b. Adjust FREQ. control.

OVEREXCITATION SHUTDOWN

The overexcitation shutdown is included to remove the regulator output power if the exciter field voltage exceeds 100 ± 5 Vdc after an inverse time delay. Refer to Section 1 for details.

After regulator output power is shutdown, the regulator can be reset by decreasing the input voltage to less than 6 Vac for a minimum of 10 seconds. This may be accomplished by stopping the prime mover or by interrupting the regulator input with the shutdown switch in series with terminals 3 or 4.

OPERATIONAL TEST

To operationally test the voltage regulator section of an ENGEN_®-100, refer to Figure 3-1 and perform the following steps in the order given:

1. Connect the voltage regulator as shown by Figure 3-1 and apply 240 Vac as shown.

2. Adjust the **VOLT (Coarse)** control fully counter-clockwise (CCW).

RESULT: Observe that the lamp does not light.

3. Adjust the **VOLT (Coarse)** control fully clockwise (CW).

RESULT: Observe that the lamp is now lit.

4. Adjust the **VOLT (Coarse)** control until the lamp just goes out.

Regulator operation is satisfactory if the above results are obtained. Stability, however, must be tested with the generator and regulator operating.

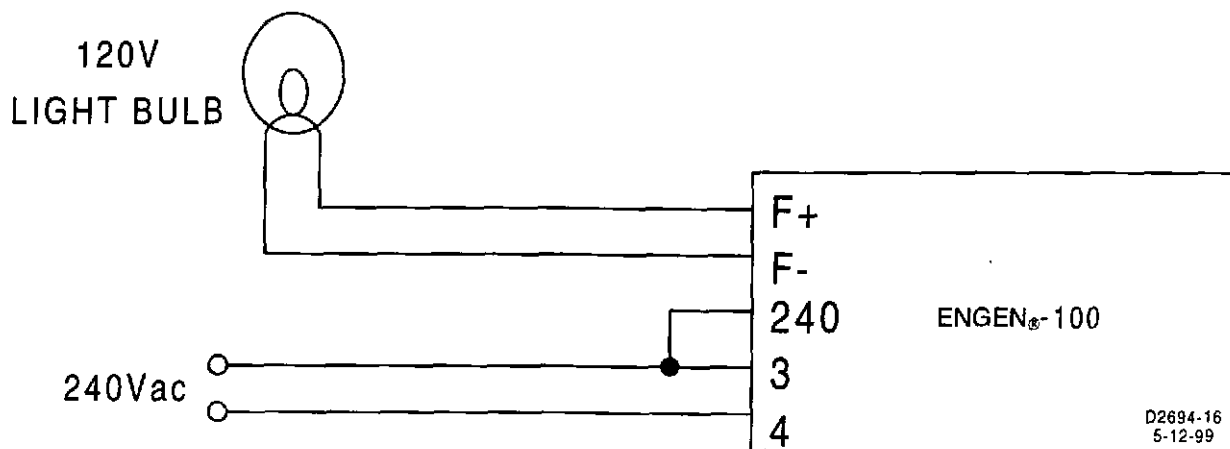

Figure 3-1. Operational Test

SECTION 4 • MAINTENANCE

PREVENTATIVE MAINTENANCE

A periodic inspection should be made of the control to ensure that it is clean and free from accumulations of dust and moisture. Be sure that all terminal connections are clean and tight. Check and clean the magnetic probe to ensure there are no magnetic filings bridging the magnetic path. Check the linkage is clean and remains free of friction or free play. If the engine/generator control fails to function properly, consult the Customer Service Department of the Power Systems Group, Basler Electric, for a return authorization number prior to shipping.

TROUBLESHOOTING

In case of failure/defective operation of the unit, the following tables (Table 4-1 and 4-2) are provided to aid in the determination of the cause and the possible solution.

Table 4-1. Troubleshooting of Voltage Regulator Functions

Symptom	Possible Cause	Remedy
Voltage does not build up.	a. Low or zero voltage to power input at terminals 3 and 4.	a. Check shutdown switch. b. Check fuses. c. Verify wiring. d. Flash field. e. Replace unit.
Voltage builds up and then decays.	a. Overexcitation circuit is shutting off regulator.	Check for overload.
	b. Defective regulator.	Replace unit.
Voltage does not build up to rated value.	a. 50/60 Hz switch (position 2) is not 'ON' (or terminals CB+ and CB- are not jumpered).	Either switch to 'ON' position or install jumper across terminals CB+ and CB-.
	b. Wrong sensing tap selected.	Check sensing tap.
	c. Internal or external voltage adjustments are improperly set.	Adjust front panel VOLT control.
	d. Underfrequency incorrectly set or speed too low.	Check underspeed switch is in correct position.
	e. Faulty regulator.	Replace unit.
Voltage high and uncontrollable.	a. No sensing input.	Verify wiring.
	b. Wrong sensing tap.	Check sensing tap.
	c. Faulty regulator.	Replace unit.

Table 4-1. Troubleshooting of Voltage Regulator Functions (Continued)

Symptom	Possible Cause	Remedy
Generator response too slow or hunting	a. Improper side panel STAB adjustment.	Re-adjust side panel STAB adjustment.
	b. Faulty regulator.	Replace unit.
Poor regulation.	a. Field resistance not matched to regulator capability or regulator output rating too low for generator requirements.	Verify specifications.
	b. Incorrect switch selection for 50 Hz or 60 Hz operation.	Check regulator for improper frequency switch installation.
	c. Low prime mover speed.	Verify prime mover speed.
	d. Faulty regulator.	Replace unit.

Table 4-2. Troubleshooting of Governor Functions

Symptom	Possible Cause	Remedy
Engine fails to start.	a. No fuel.	Check fuel level, fuel line for air, and fuel valve (and relevant wiring).
	b. Actuator not pulling in.	a. Check wiring. b. Replace actuator.
	c. Magnetic probe not connected or inadequate signal.	a. Check probe wiring and positioning; replace probe if necessary. b. Check voltage output of mag-pickup.
	d. Supply voltage inadequate.	Check wiring and/or replace battery.
	e. Faulty governor.	Replace unit.
Engine starts but stops again shortly afterwards	a. Oil pressure too low.	a. Check number of LED flashes to determine fault (See Table 4-3).
	b. Water temperature too high.	b. Check oil pressure and engine temperature.
	c. Overspeed shutdown due to speed overshoot.	Readjust speed setting and PID gains.
	d. Sender(s) faulty.	Replace sender(s).
Poor speed regulation.	a. Integral adjustment incorrect.	Re-adjust integral gain.
	b. Load too high for engine.	Reduce load to rated value.

Table 4-2. Troubleshooting of Governor Functions (Continued)

Symptom	Possible Cause	Remedy
Engine response too slow or oscillating.	a. Improper PID adjustment.	Re-adjust PID adjustment as in section 3-4 (d).
	b. Magnetic probe signal inadequate or noisy.	a. Check wiring/connections/ probe position; clean and/or replace probe. b. Check for electrical noise due to inadequate probe cable or screen grounding.
	c. Linkage adjustment incorrect or sticking.	Clean and/or re-position linkage.
	d. Faulty governor.	Replace unit.
	e. Actuator improperly sized	Resize actuator to more closely match actual force required by the fuel system.
	f. Improper frequency range selected.	Select another range which covers the mag-pickup frequency input and readjust PID settings.

Table 4-3. Front Panel Diagnostic 'Alarm Condition' LED Indication

Flashes	Cause	Remedy
1, 2, 3	Internal Microprocessor fault.	Replace unit if indication is recurrent.
4	Not used.	N/A
5	Actuator or governor output failure.	Check actuator * and wiring; replace actuator if necessary.
6	Not used.	N/A
7	Loss of speed/signal.	Check probe** for position, for filings on tip and probe wiring and connections. Replace probe if necessary.
Continuously Lit	Common alarm input signal.	An external device has detected a fault condition. Check external devices.

***Actuator Check:-**

Disconnect actuator from controller and measure resistance between actuator wires and case. If less than 1 Megohm, replace actuator. Measure resistance of coil according to Table 1-5. If resistance is substantially different to value in table, replace actuator. Apply battery volts across actuator terminals; actuator should move to maximum fuel position. If it does not, controller may be faulty, therefore, check linkage for binding.

****Probe check:-**

Disconnect probe from controller and measure resistance between probe wires and case. If less than 1 Megohm, replace probe. Measure resistance across probe wires; a value of 144 to 198 ohms is normal. If probe is short or open circuit, replace it. Check that at cranking a voltage of greater than 2V pk-pk is present; if not check probe gap and probe tip for filings. If adequate voltage is present, controller may be faulty.

OTHER LED FAULT INDICATIONS

Low Oil Pressure LED

ENGEN₆-100 shuts down the engine after 1 second when low oil pressure is detected; the Low Oil Pressure LED is illuminated. On start-up, this function is inhibited for 10 seconds after Crank disconnect.

High Water Temperature LED

ENGEN₆-100 shuts down the engine after 1 second when high water temperature is detected; the High Water Temperature LED is illuminated. On start-up, this function is inhibited for 60 seconds after crank disconnect.

Overspeed LED

ENGEN₆-100 shuts down the engine immediately when 125% of set speed is detected; the Overspeed LED is illuminated.

Overcrank LED

If the engine fails to start after the preset number of start attempts, the cranking is terminated and the Overcrank LED is illuminated.

Common Alarm Out

A common alarm output is provided for remote annunciation. If the engine is shutdown due to any of the above faults, the common alarm output contacts will close. These contacts are rated at 10A (30 Vdc or 277 Vac).

NOTE

Any one of the above functions is latched as the 'first-up' fault and subsequent faults are ignored. The indicated fault can only be reset by removal of power to the ENGEN₆-100 unit by switching the main front panel switch to the center 'OFF' position. It should be noted that if the engine should stall or stop for any other reason (such as running out of fuel or other mechanical reason), ENGEN₆-100 will detect a loss of speed or low oil pressure situation and latch this as a fault.

NOTE

The lamp test Push-button enables all front panel LED's to be tested simultaneously. This is not functional in the OFF position.

REPLACEMENT PARTS

The following Table 4-4 lists the recommended replacement parts. When ordering parts from Basler Electric, be sure to specify the part number, quantity, and description.

Table 4-4. Replacement Parts

Description	Quantity	Basler Part Number
Fuse, 10A, 250V	1	18347

SECTION 5 • MANUAL CHANGE INFORMATION

CHANGES

Substantive changes in this manual to date are summarized in Table 5-1.

Table 5-1. Summary of Changes

Revision	Summary of Changes	ECO No.	Date
A	Added the Registered R symbol behind the word ENGEN	5215	2/97