

Genset Control System
PowerCommand[®] Control 3100 PCCP

Document No. 3535(GB) Issue 03 April '04

FOREWORD

The purpose of this manual is to provide the users with sound, general information. It is for guidance and assistance with recommendations for correct and safe procedures. Cummins Power Generation Limited cannot accept any liability whatsoever for problems arising as a result of following recommendations in this manual.

The information contained within the manual is based on information available at the time of going to print. In line with the Cummins Power Generation Limited policy of continual development and improvement, information may change at any time without notice. The users should therefore ensure that before commencing any work, they have the latest information available.

Users are respectfully advised that it is their responsibility to employ competent persons to carry out any installation work in the interests of good practice and safety. Consult your Authorised Distributor for further installation information. It is essential that the utmost care is taken with the application, installation and operation of any diesel engine due to their potentially dangerous nature. Careful reference should also be made to other Cummins Power Generation Limited literature, in particular the Health and Safety Manual (3553) and the Engine Operation and Maintenance Manual.

Should you require further assistance contact: -

Cummins Power Generation Limited
Columbus Avenue
Manston Park
Manston
Ramsgate
Kent CT12 5BF

Tel. No.: +44 (0) 1843 255000

Fax. No.: +44 (0) 1843 255902

e-mail: cpg.uk@cummins.com

Web Site: www.cumminspower.com

CONTENTS

Section	Title	Page
	Schedule of Abbreviations	i
1	Safety	1-1
1.1	Warning, Caution and Note Styles Used In This Manual	1-1
1.2	Warnings	1-1
1.3	General Information	1-1
1.4	Generator Plant Safety Code	1-1
2	Introduction	2-1
2.1	General	2-1
2.2	Generating Set Identification	2-1
2.3	After Sales Services	2-2
2.3.1	Maintenance	2-2
2.3.2	Warranty	2-2
2.3.3	Spares	2-2
2.3.4	Overseas	2-2
3	System Description	3-1
3.1	Generator Components – Typical Genset	3-1
3.1.1	Control System	3-2
3.1.2	Engine	3-2
3.1.3	Alternator	3-2
3.1.4	Generator Rating	3-2
3.1.5	Generator Construction	3-2
3.2	Fuel System	3-2
3.2.1	Fuel Transfer Pumps (Option)	3-2
3.2.2	Fuel / Water Separators	3-3
3.3	Cooling System	3-3
3.4	Engine Exhaust (Option)	3-3
3.5	DC Electrical System	3-3
3.5.1	Battery System	3-3
3.5.2	Charge Alternator	3-3
3.5.3	Mains Powered Battery Charger (Option)	3-3
3.6	Alarm Module (Option)	3-3
3.7	Sensors / Senders	3-4
3.8	Heaters	3-4
3.8.1	Engine Heater (Option)	3-4
3.8.2	Alternator Heater (Option)	3-4
3.8.3	Control Panel Heater (Option)	3-5
3.9	Mains Powered Battery Charger (Option)	3-5
3.9.1	Operation	3-5
3.9.2	Boost Charge (Option)	3-5
3.10	Communications Network (Option)	3-5
3.11	Remote Start / Stop Scheduling (Option)	3-5
3.12	Earth Fault (Option)	3-6
3.13	Circuit Breakers and Change-over Contactors	3-6
3.13.1	Circuit Breakers (Option)	3-6
3.13.2	Change-over Panel (Option)	3-6
3.14	Starting Control System	3-7
3.14.1	Customer Connections	3-7
3.14.2	Output Contacts	3-8
3.14.3	DC Power	3-8
3.15	Paralleling Protection	3-8
3.15.1	Commonly Asked Questions About AmpSentry™ Control Systems	3-9

CONTENTS (continued)

Section	Title	Page
4	Control System	4-1
4.1	Control System Description.....	4-1
4.1.1	Control Mode Definitions	4-2
4.1.2	Control Panel Power ON/OFF Modes.....	4-3
4.1.3	Control Panel – Front Panel	4-4
4.1.4	Control Panel Switches and Indicators.....	4-5
4.2	Menu Display and Switches.....	4-9
4.2.1	Alphanumeric Display and Switches.....	4-9
4.2.2	Main Menu.....	4-10
4.2.3	Engine Menu	4-12
4.2.4	Gen Menu.....	4-14
4.2.5	Adjust Menu	4-16
4.2.6	Version Menu	4-18
5	Operation	5-1
5.1	Safety	5-1
5.2	Introduction.....	5-1
5.3	Maintenance	5-1
5.4	Operating Recommendations	5-2
5.4.1	Running-In.....	5-2
5.4.2	No-Load Operation.....	5-2
5.4.3	Exercise Period	5-2
5.4.4	Low Operating Temperature.....	5-2
5.4.5	High Operating Temperature.....	5-2
5.5	Genset Operation.....	5-3
5.5.1	Sequence of Operation.....	5-3
5.6	Starting	5-3
5.6.1	Pre-Start Checks	5-4
5.7	Start / Run Procedures	5-6
5.7.1	Operating Options	5-6
5.7.2	Lockout.....	5-6
5.7.3	Start Procedure	5-7
5.8	Paralleling	5-8
5.8.1	Speed and Voltage Matching.....	5-8
5.8.2	Operation When in Parallel.....	5-8
5.9	Shutdown Procedures.....	5-9
5.9.1	Normal Stop	5-9
5.9.2	Emergency Stop	5-9
5.9.3	Emergency Stop Controls.....	5-10
5.9.4	Emergency Stop Reset.....	5-10
5.10	Fault Alarms & Shutdowns.....	5-11
5.10.1	Alarm.....	5-11
5.10.2	Controlled Shutdown	5-11
5.10.3	Immediate Shutdown.....	5-11
5.11	Genset Output Metering.....	5-12
5.11.1	Load Voltage	5-12
5.11.2	Load Current	5-12
5.11.3	Load Power	5-13
5.11.4	Genset Frequency	5-13
5.11.5	Bus Synchronisation.....	5-13
5.11.6	Duty Cycles	5-13

CONTENTS (continued)

Section	Title	Page
5.12	Engine Metering.....	5-14
5.13	Options	5-15
5.13.1	Heaters.....	5-15
5.13.2	Digital Master Control.....	5-15
6	Maintenance	6-1
6.1	General.....	6-2
6.2	Locking the Genset Out of Service	6-5
6.2.1	Introduction	6-5
6.2.2	Immobilising the Plant for Safe Working.....	6-5
6.3	General Inspection.....	6-6
6.3.1	Exhaust System	6-6
6.3.2	Fuel System	6-6
6.3.3	AC Electric System.....	6-6
6.3.4	DC Electrical System.....	6-7
6.3.5	Engine	6-7
6.3.6	Mechanical	6-7
6.4	Lubrication System	6-8
6.4.1	Oil API Classification	6-8
6.4.2	Oil Viscosity.....	6-8
6.4.3	Engine Oil Level	6-8
6.4.4	Oil and Filter Change	6-8
6.4.5	Starting Procedure After Extended Shutdown or Oil Change	6-8
6.5	Coolant System	6-9
6.5.1	Anti-freeze Concentration.....	6-9
6.5.2	Coolant Level	6-9
6.5.3	Cooling System Maintenance.....	6-10
6.5.4	Radiator.....	6-11
6.5.5	Fan Bearings Re-lubrication	6-11
6.5.6	Coolant Heater	6-12
6.6	Heat Exchanger Cooling System (Optional).....	6-12
6.7	Fuel System.....	6-13
6.7.1	Fuel Handling Precautions	6-13
6.8	Air Cleaner.....	6-13
6.9	AC Generator Bearing Re-lubrication	6-14
6.9.1	Lubrication.....	6-14
6.9.2	Re-Lubrication Procedure.....	6-15
6.10	Test Runs	6-16
6.10.1	Pre-start Checks.....	6-16
6.10.2	Off-load Initial Run.....	6-16
6.10.3	On-load Initial Run.....	6-17
6.10.4	Maintenance Test Run	6-19

CONTENTS (continued)

Section	Title	Page
7	Troubleshooting	7-1
7.1	Introduction.....	7-1
7.2	Safety Considerations.....	7-1
7.3	Fault Finding.....	7-2
7.4	Status Indicators.....	7-3
7.4.1	Not in Auto Indicator.....	7-3
7.4.2	Shutdown Status Indicator.....	7-3
7.4.3	Warning Status Indicator.....	7-3
7.5	Reading Fault Codes.....	7-3
7.5.1	Engine Starting Faults.....	7-4
7.5.2	Engine Running Faults.....	7-5
7.5.3	Electrical Output Faults.....	7-7
7.5.4	Control System Faults.....	7-9

Illustrations

Figure	Title	Page
Figure 2-1	Typical Genset Rating Plate.....	2-1
Figure 3-1	Typical Genset.....	3-1
Figure 3-2	Alarm Module Front Panel.....	3-3
Figure 3-3	Time-over Current Curve.....	3-12
Figure 4-1	Front Panel.....	4-4
Figure 4-2	Alphanumeric Display and Switches.....	4-9
Figure 4-3	Main Menu.....	4-11
Figure 4-4	Engine Menu.....	4-13
Figure 4-5	Gen Menu.....	4-15
Figure 4-6	Adjust Menu.....	4-17
Figure 4-7	Version Menu.....	4-19
Figure 6-1	Typical After Cooler/Water Jacket Coolant Drain Locations.....	6-10
Figure 6-2	Fan Bearing Grease Fittings.....	6-11
Figure 6-3	Typical Coolant Heater.....	6-12
Figure 7-1	Front Panel.....	7-3

Tables

Figure	Title	Page
Table 4-1	Control Mode Definitions.....	4-2
Table 6-1	Suggested Maintenance Schedule.....	6-3
Table 6-2	Additional Maintenance Schedule.....	6-4
Table 6-3	Maintenance Chart for Re-Grease.....	6-14

Supplementary Publications

The Supplementary Publications appropriate to your system will also be supplied with the system. Where appropriate the corresponding Instruction Manual(s) will also be supplied with any accessory that you order.

Title	Publication No
Lead Acid Battery.....	3330
Battery Charger.....	3393
Health and Safety (Diesel Sets).....	3553
Radiator Information.....	3554

Schedule of Abbreviations

AC	Alternating Current	MCB	Miniature Circuit Breaker
ACB	Air Circuit Breaker	MCCB	Moulded Case Circuit Breaker
ACH	Anti-Condensation Heaters	MF	Mains Failed
ATS	Automatic Transfer Switch	MFSS	Master First Start Sensor
AVR	Automatic Voltage Regulator	MR	Mains Returned
		MST	Mains Sensing Transformer
BHP	Brake Horsepower	MSU	Mains Sensing Unit
BMS	Building Management System	MV	Medium Voltage
BST	Busbar Sensing Transformer		
		NEC	Neutral Earthing Contact
CB	Circuit Breaker		
CCA	Cold Cranking Amps	PCCP3100	PowerCommand® Control Paralleling
CHP	Combined Heat and Power	PF	Power Factor
COP	Continuous Power Rating	PFC	Power Factor Controller
CT	Current Transformer	PLC	Programmable Logic Controller
		PMG	Permanent Magnet Generator
dB(A)	Unit of noise level	PRP	Prime Power Rating
DC	Direct Current	PSU	Power Supply Unit
DIP	Dual In-line Package	PT/CT	Potential Transformer / Current Transformer
DMC	Digital Master Control™		
DMSU	Demand Load Standby Unit	QCC	Quadrature Current Control
EMCU	Engine Monitoring and Control Unit		
EMF	Electromotive Force	RFI	Radio Frequency Interference
EPU	Engine Protection Unit	RMS	Root Mean Square
		RPM	Revolutions Per Minute
FSS	First Start Sensor	RTD	Resistive Temperature Detector
GCP	Generator Control Panel	V	Volts
Genset	Generator Set	VAC	Volts, Alternating Current
GKWT	Global Kilowatt Transducer	VCB	Vacuum Circuit Breaker
		VDC	Volts. Direct Current
HV	High Voltage	VF	Volt-free
		VT	Voltage Transformer
IC	Integrated Circuit		
I/O	Input / Output		
kVA	Apparent Power		
kVAR	Reactive Power		
kW	Active / Real Power		
kWh	Unit of electrical energy or work		
LED	Light-Emitting Diode		
LTP	Limited Time Power Rating		
LV	Low Voltage		

SECTION 1 – PRELIMINARY AND SAFETY

1 Safety

1.1 Warning, Caution and Note Styles Used In This Manual

The following safety styles found throughout this manual indicate potentially hazardous conditions to the operator, service personnel or the equipment.

WARNING: WARNS OF A HAZARD THAT MAY RESULT IN SEVERE PERSONAL INJURY OR DEATH.

Caution: Warns of a hazard or an unsafe practice that can result in product or property damage.

Note: A short piece of text giving information that augments the current text.

1.2 Warnings

WARNING: IT IS IMPORTANT TO READ AND UNDERSTAND ALL SAFETY NOTICES PROVIDED IN THIS MANUAL. IMPROPER OPERATION OR MAINTENANCE COULD RESULT IN A SERIOUS ACCIDENT, OR DAMAGE TO THE EQUIPMENT, CAUSING INJURY OR DEATH.

1.3 General Information

This manual should form part of the documentation package supplied by Cummins Power Generation Limited with specific generator sets. In the event that this manual has been supplied in isolation please refer to other Cummins Power Generation Limited literature, in particular the Health and Safety Manual (3553) and the Operation and Maintenance manuals relevant to your genset.

Note: It is in the user's interest to read and understand all Health and Safety information together with all Warnings and Cautions contained within the documentation relevant to the genset and its operation and maintenance.

1.4 Generator Plant Safety Code

Before operating the genset, read the Health and Safety Manual (3553), the Operation and Maintenance manuals and become familiar with them and the equipment. Safe and efficient operation can only be achieved if the equipment is operated and maintained correctly. Many accidents are caused by failure to follow fundamental rules and precautions.

SECTION 2 - INTRODUCTION

2 Introduction

2.1 General

Before any attempt is made to operate the generator, the user should take time to read this manual and to familiarise him or herself with the Warnings and Operating Procedures.

A genset must be operated and maintained properly if safe and reliable operation is to be expected. The manual includes a maintenance schedule and a troubleshooting guide.

The engine manual is included with the set. Where there is conflicting information, this manual takes precedence over the engine manual.

2.2 Generating Set Identification

Each generating set is provided with a Generating Set Rating Plate as shown below. This provides information unique to the generator.

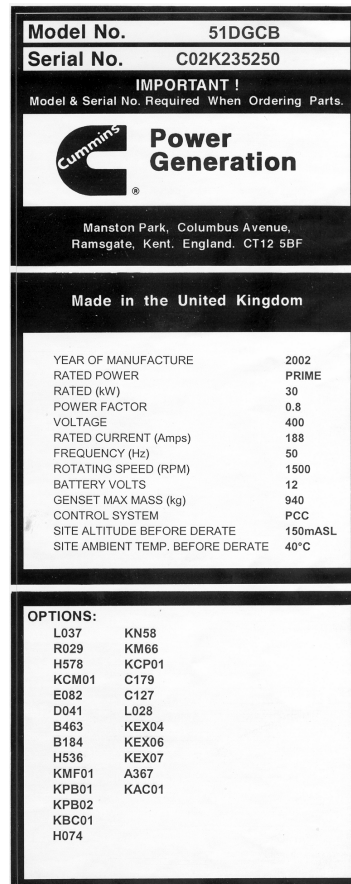

Figure 2-1 Typical Genset Rating Plate

2.3 After Sales Services

We offer a full range of after sales services as follows:

2.3.1 Maintenance

<p>WARNING: INCORRECT SERVICE OR PARTS REPLACEMENT CAN RESULT IN SEVERE PERSONAL INJURY, DEATH AND/OR EQUIPMENT DAMAGE. SERVICE PERSONNEL MUST BE TRAINED AND EXPERIENCED TO PERFORM ELECTRICAL AND/OR MECHANICAL SERVICING.</p>

For customers who wish to have their gensets expertly serviced at regular intervals the Customer Service Department offers a complete maintenance contract package. This covers all items subject to routine maintenance and includes a detailed report on the condition of the set. In addition, this can be linked to a 24-hour call-out arrangement, providing assistance 365 days a year if necessary. Specialist engineers are available to maintain optimum performance levels from customer's gensets, and it is recommended that maintenance tasks are only undertaken by trained and experienced engineers provided by the Customer Service Department.

2.3.2 Warranty

All gensets have a twelve months warranty from the commissioning date as standard. Extended warranty coverage is also available. In the event of a breakdown prompt assistance can normally be given by factory trained service engineers with facilities to undertake all minor and many major repairs to equipment on site.

For further warranty details, contact your authorised distributor.

2.3.3 Spares

An extensive Spare Parts Department is available for any emergency breakdown and for the engineer who carries out his own routine maintenance. Please contact your authorised Cummins Distributor.

Please quote Plant Nos., Serial Nos., and Part Nos. when ordering spares.

2.3.4 Overseas

Agents and representatives in almost 100 countries throughout the world offer installation and after sales service for the equipment provided. We can provide the name and address of the agent for your specific location.

For details on any of the above services contact your distributor.

SECTION 3 – SYSTEM DESCRIPTION

3 System Description

3.1 Generator Components – Typical Genset

The main components of a typical Generator System are shown below. Refer to the Engine and Alternator Manuals for location of other components, e.g. oil filler, dipstick, etc. Various options are available although they may differ between models.

Note that the Load Terminal Box, item 9, is mounted optionally on the left or right side and includes the load connection gland plate (with optional entry point location).

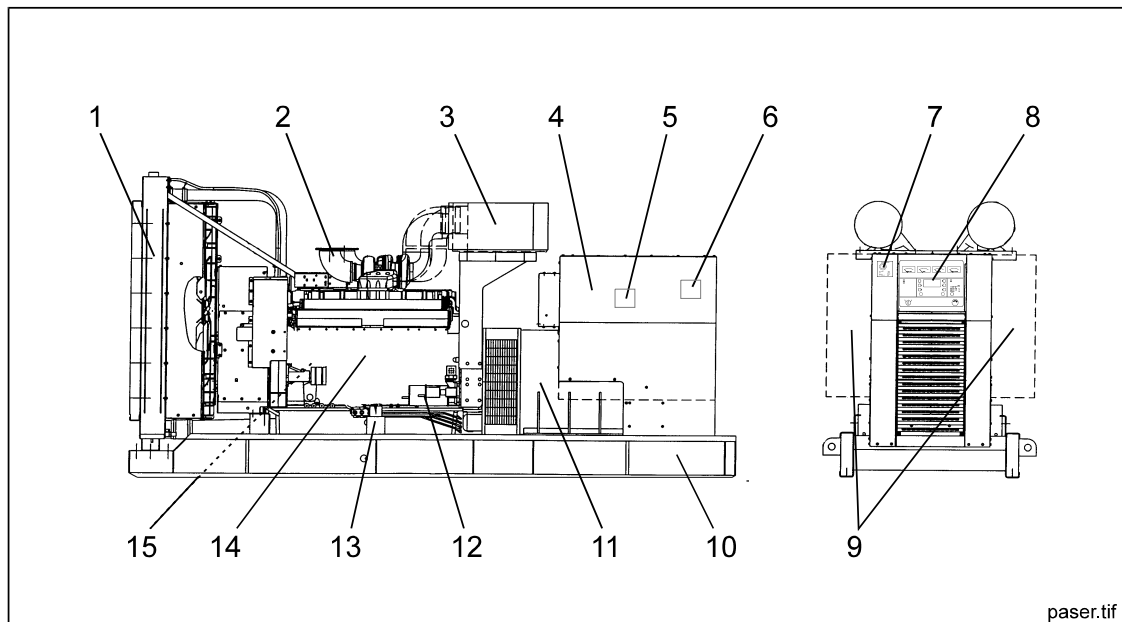

Figure 3-1 Typical Genset

KEY:

- | | |
|--|------------------------------|
| 1. Radiator | 9. Load Terminal Box (LH/RH) |
| 2. Exhaust Outlets | 10. Bedframe |
| 3. Air Cleaners | 11. Alternator |
| 4. Control Housing | 12. Starter Motor |
| 5. Load Output Circuit Breaker (LH/RH) | 13. Coolant Heater (Option) |
| 6. Generating Set Rating Plate (LH/RH) | 14. Engine |
| 7. Alarm Module (Option) | 15. Oil Filters (RH side) |
| 8. PowerCommand™ Control Panel | |

3.1.1 Control System

The control system is a micro-processor based control for gensets (see Section 4), providing automatic paralleling. It provides fuel control and engine speed governing, main alternator voltage output regulation, and complete genset control and monitoring. The control also monitors the health of the engine, alternator and auxiliary systems continuously, and will affect an Automatic Shutdown if a serious fault occurs.

The main control panel and its associated equipment are located in the Control Housing, which is mounted on either the left or the right of the housing, as required for the site. All indicators, control switches/buttons and the digital display are on the face of the control panel as illustrated in Figure 4-1.

3.1.2 Engine

All generators employ a 4-stroke, water-cooled engine and incorporate a governor control and full engine protection system. Refer to the Generating Set Rating Plate for engine type and rating details.

For further information refer to the Engine manufacturer's Operation and Maintenance Manual supplied with this manual.

3.1.3 Alternator

All generator types use AC alternators of a brushless, rotating field design, which eliminates the maintenance associated with slip rings and brushes. Refer to the Generating Set Rating Plate for alternator type and rating details.

For further information refer to the Alternator manufacturer's Installation, Service and Maintenance Manual supplied with this manual.

3.1.4 Generator Rating

For details of your generator rating refer to the Generating Set Rating Plate.

3.1.5 Generator Construction

Most generators are constructed as a single module with the engine and alternator connected through a coupling chamber with resilient mountings to form one unit. The engine and alternator are mounted on a bedframe on resilient mountings. This results in one unit of immense strength and rigidity, with accurate alignment between the engine and alternator, and effective damping of engine vibration.

3.2 Fuel System

A base fuel tank formed from fabricated sheet sections can be provided as an option. The tank is fitted with a large filler cap with in-built coarse filter, and provides a minimum of eight hours operation at a nominal 100% load.

Free standing main tanks with stands providing 450, 900 and 1350 litre capacity are available as options.

3.2.1 Fuel Transfer Pumps (Option)

Free standing fuel tanks can be filled manually using an optional hand fuel transfer pump.

Alternatively, fuel tanks (base tank or free standing) can be filled automatically using an electrical fuel transfer pump. This pump, which is supplied complete with starter, operates under the control of Low and High Fuel Level switches fitted to the tank.

On automatically filled systems, the base tank filler cap is replaced with an overflow / breather connection to allow piping to a safe area or return to a bulk tank.

3.2.2 Fuel / Water Separators

Set-mounted fuel/water separators are fitted as standard to provide protection for the engine fuel injection system as water-free fuel supplies cannot be guaranteed.

3.3 Cooling System

The engine cooling system consists of a radiator and pusher fan, mechanically driven water pump and a thermostat. The fan drives air through the radiator and removes surface heat from the engine and alternator.

The alternator has its own internal cooling fan.

3.4 Engine Exhaust (Option)

Exhaust systems, which are optional and supplied in loose form, reduce engine noise to acceptable levels and pipe exhaust gases to an area where they will not present a hazard. Industrial and residential types are available as options. Flexible bellows are also available as an option.

3.5 DC Electrical System

A 12 or 24 volt battery system (determined by generator type) provides multi-attempt engine starting and DC power for the generator control system.

3.5.1 Battery System

Battery type, size and voltage are selected to suit the generator capacity and application on ordering.

3.5.2 Charge Alternator

An engine driven charge alternator is provided as standard to maintain the battery in a charged condition when the engine is running.

3.5.3 Mains Powered Battery Charger (Option)

Optional single phase, mains powered battery chargers, which can be panel or wall mounted, are available to maintain the battery in a charged condition when the generator is not running.

3.6 Alarm Module (Option)

The Alarm Module provides audible warnings. The front panel has a warning horn, two indicator lights and one spring-loaded push-switch. The two indicator lights, Alarm and Horn Silenced, show respectively that the horn has been activated and that the adjacent Push-to-Silence-Horn push-switch has been pressed.

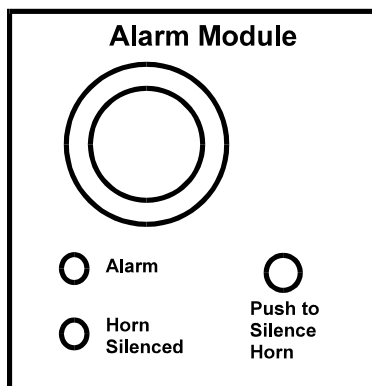

Figure 3-2 Alarm Module Front Panel

3.7 Sensors / Senders

Various genset parameters are measured by sensors, senders, RTDs etc and the resulting signals are applied to the PCCP.

Engine-mounted sensors are able to monitor the following systems:

- Fuel
- Lube Oil
- Cooling System
- Charge Air / Exhaust
- Miscellaneous Areas

Alternator-mounted sensors are able to monitor the following parameter (option) —

- Winding Temps

3.8 Heaters

Caution: Heater(s) must not be energised if the coolant system has been drained.

Caution: Remove AC power to the heater before disconnecting battery leads. Heater will run continuously without DC power and can overheat and damage heater.

3.8.1 Engine Heater (Option)

The engine heater is designed to keep the engine coolant warm when the engine is shut down. It heats and circulates the coolant within the engine, reducing start-up time and engine wear caused by cold starts. The heater is controlled by an associated thermostat, but is locked out by the PCCP at engine start.

The engine heater is supplied with 230V AC via the engine heater supply, the associated thermostat and an isolator relay. The relay is controlled by the PCCP.

The engine mounted engine heater isolator switch should normally be left in the On position. When the engine is running, heater operation is controlled automatically by a relay and thermostat.

WARNING: ALWAYS ISOLATE THE SUPPLY TO THE ENGINE HEATER / THERMOSTAT BEFORE CARRYING OUT ANY MAINTENANCE ON THE ENGINE. ALWAYS ISOLATE THE GENSET PRIOR TO ANY MAINTENANCE.

Caution: The engine heater is in no way intended to protect the engine and cooling system from freezing in sub zero conditions. If there is any danger from freezing, then a suitable antifreeze agent must be added to the cooling system.

3.8.2 Alternator Heater (Option)

The alternator heater is designed to keep the alternator free of condensation when the genset is not running. During cool and humid conditions, condensation can form within the alternator, which can create flashing and a shock hazard. The heater is locked out by the PCCP at engine start.

The alternator heater is supplied with power via the engine heater isolator switch, which should normally be left in the On position as heater operation is controlled automatically by a relay and thermostat. The relay is controlled by the PCCP.

WARNING: ALWAYS ISOLATE THE ALTERNATOR HEATER FROM THE AC SUPPLY BEFORE WORKING ON THE ALTERNATOR OR HEATER.

3.8.3 Control Panel Heater (Option)

The control panel heater provides a means of humidity / temperature control within the control box interior. It protects the components and ensures their effectiveness when the genset is subjected to varying ambient air conditions during extended periods of non-use. The heater is locked out by the PCCP at engine start.

The alternator heater is supplied with power via the Engine Heater Isolator switch, which should normally be left in the On position as heater operation is controlled automatically by a relay and thermostat. The relay is controlled by the PCCP.

WARNING: ALWAYS ISOLATE THE CONTROL PANEL HEATER FROM THE AC SUPPLY BEFORE WORKING ON THE CONTROL PANEL OR HEATER.

3.9 Mains Powered Battery Charger (Option)

3.9.1 Operation

This unit maintains the battery in a fully charged condition without over-charging. The unit also provides rapid charging, when necessary, at a current up to the rated output.

The charger's electronic control circuit allows the charger to be left in circuit during engine cranking and to operate in parallel with the charge alternator.

The charger will supply current to the battery system when the battery terminal voltage is equal to the set float voltage, at which point only a trickle charge current is present. When the battery becomes discharged due to a load being present and the terminal voltage falls, the charger will again supply current to restore the voltage of the battery to the float voltage.

Should a charge fail condition occur for longer than ten seconds then the charge fail relay will energise, and its contact close. Charger operation is indicated by a red LED.

Note: *The LED will light even if the charger output fuse is blown.*

3.9.2 Boost Charge (Option)

During trickle charging, not all cells in the battery receive the same charge and over a period of several months this may affect battery performance. It is therefore normal to give batteries a regular charge at their **full rate** to return all cells to full capacity. This is referred to as Boost Charging (also known as equalise charging).

If the charger is fitted with a Boost Charge switch, the Boost position should be selected at intervals detailed by the battery manufacturer (normally around every six months).

Caution: *Batteries should not be left on Boost Charge for extended periods as this will result in excessive water consumption, gassing and may impair battery performance.*

3.10 Communications Network (Option)

The PCCP system includes a Generator Control Module (GCM) which provides for communications over the PCCP Communications Network. The network is suitable for local or remote control and monitoring functions using PCCP Software for Windows™.

3.11 Remote Start / Stop Scheduling (Option)

PCCP Software for Windows™ provides for remote monitoring of the genset, or set of gensets, using a laptop PC. The software provides detailed information on the status of the gensets and their associated accessories.

A remote access, single-site version of PCCP is provided for each site. Alternatively, one remote access, multi-site version of PCCP can be provided for a host monitoring computer.

3.12 Earth Fault (Option)

The Earth Fault option, which employs an earth fault unit, is designed to detect current flow in the neutral earth and provide a Shutdown alarm on the detection of an earth fault.

A separate Earth Fault Reset button is provided on the control housing to allow resetting of an earth fault alarm. The resulting Shutdown indication on the control unit must be reset, using the Reset membrane switch on the front panel - see Section 4.1.3.

3.13 Circuit Breakers and Change-over Contactors

3.13.1 Circuit Breakers (Option)

All generators can be equipped with optional mechanically operated 3 or 4-pole circuit breakers (MCCBs), mounted in the Load Terminal Box. The circuit breaker is used to isolate the generator output from the load.

Up to 1250 amp generator rating circuit breakers are installed in a Set-mounted load box which is close coupled to the alternator output terminal box. Customer cables are fed to the circuit breaker via a bottom or side exit gland plate.

Above 1250 amp generator rating circuit breakers are installed in a free-standing enclosure. With this arrangement the control panel remains Set-mounted using resilient mountings to reduce vibration.

3.13.2 Change-over Panel (Option)

Change-over panels, fitted with either 3 or 4-pole contactors, are available as options.

Up to 1250 amp generator rating change-over panels are wall mounted.

Above 1250 amp generator rating change-over panels are free standing.

3.14 Starting Control System

PCCP uses a multi-function control system, which integrates fuel ramping and field excitation, to minimise frequency and voltage overshoot and to limit black smoke emission on starting. This control system includes the following functions:

1. **Fuel Ramping** - Upon receiving the Start signal, the digital control system energises the engine fuel system sufficiently to allow the engine to start. When the control system senses that the engine has reached start disconnect speed, it gradually increases fuel flow to ramp up the engine speed thus controlling acceleration up to rated operating conditions. This minimises black smoke emission and frequency overshoot, as well as improving cold starting capability.
2. **Fail to Crank** - As the Start signal is initiated, the control system checks the speed monitoring pick-up to check that the engine is rotating. If the engine is not rotating, the control system switches off the starter and then makes two further attempts. If the final attempt fails, a Shutdown message is signalled on the alphanumeric display and the genset cannot be started until the fault has been cleared. This process helps prevent starter or ring gear damage.
3. **Temperature Dynamic Governing** - A temperature dynamic adjustment capability enhances cold starting ability, and improves stability when the engine is cold starting, by automatically adjusting governing characteristics based on engine temperature. It also helps limit black smoke emission on cold starting.
4. **Digital Excitation Control** - The genset voltage regulation system is 3-phase sensing and includes torque matching to provide enhanced load pick-up capability. During starting, the control system ramps output voltage to rated value to minimise voltage overshoot.
5. **Cycle Cranking** - The PCCP system includes a standard cycle cranking system, which allows the operator to select continuous or cycle cranking mode. The operator can select between three and six cranking cycles, and adjust the crank/rest times between seven and twenty seconds. The standard setting is three cranking cycles, with five seconds crank duration followed by ten seconds rest.
6. **Battery Monitoring System** - The PCCP system continuously monitors the battery charging system for low and high DC voltage. Functions and messages include:
 - **Low DC voltage** - battery voltage less than 24VDC (12VDC for 12V battery)
 - **High DC voltage** - battery voltage greater than 32VDC (16VDC for 12V battery)
 - **Weak battery** - main battery droop is monitored at start-up and, if the voltage drops below 60% of nominal for more than two seconds, the indication will be given
7. **First Start Sensor** - Provides a positive interlock to prevent multiple gensets from simultaneously closing to a dead system bus. A back-up system is provided to allow normal system operation in the event that the Primary First Start Sensor fails.

3.14.1 Customer Connections

All customer connections to the PCCP are made in the control housing, which is mounted on the genset bedframe. Connections are made via large, clearly labelled terminal blocks.

3.14.2 Output Contacts

The PCCP provides control, alarm and status output signals, which are used to energise/de-energise associated relays. The relays are located within the PCCP panel and contacts are provided for customer use. Signals are provided for the following relays:

- **Common Warning alarm relay** - Operates on all Warning conditions. Rated at 2A, 30VDC
- **Common Shutdown alarm relay** - Operates on all Shutdown conditions. Rated at 2A, 30VDC
- **Ready to load relay** - Operates when the genset reaches 90% of rated voltage and frequency. Rated at 2A, 30VDC
- **Auxiliary Run relays** (up to three, optional) - Each relay is rated at 2A, 30VDC
- **Breaker operation contacts** - Provide breaker open and breaker close signals for a paralleling circuit. Rated at 5A, 30VDC
- **Load shed relay** - Operates for a specified period of time when an Overload warning occurs. Rated at 6A, 30VDC

3.14.3 DC Power

The PCCP system is powered by the genset's battery system. The control system will function over a voltage range between 8 and 34VDC.

3.15 Paralleling Protection

The PCCP system incorporates AmpSentry™ Protection for automatic paralleling operations. This is a comprehensive power monitoring and control system that guards the electrical integrity of the alternator and power system from the following effects:

- Overcurrent
- Short circuit
- Over/under voltage
- Over/under frequency
- Overload
- Reverse power
- Loss of excitation
- Alternator phase rotation
- Paralleling circuit breaker failure to close

Current flow is regulated to 300% for both single phase and 3-phase faults when a short circuit condition is sensed.

If the genset is operating for an extended period at a potentially damaging current flow level, an Overcurrent alarm will sound to warn the operator of an impending problem before it causes a system failure. If an Overcurrent condition persists for the time pre-programmed in the time current characteristic for the alternator, the Permanent Magnet Generator (PMG) excitation system is de-energised, avoiding alternator damage. The Overcurrent protection is time delayed in accordance with the alternator thermal capacity. This allows current to flow until secondary fuses or circuit breakers operate, isolating the fault and thus achieving selective co-ordination (discrimination).

After the fault is cleared, AmpSentry™ Protection softly loads the genset by controlled ramping of output voltage to rated level, allowing the genset to resume normal operation without a potentially damaging voltage overshoot.

Fixed over/under voltage and under frequency time delayed set points also provide a degree of protection for load equipment. Over/under voltage conditions trigger a Shutdown message on the alphanumeric display; and under frequency conditions prompt both a Warning and Shutdown message, depending on the length of time and magnitude of variance under rated frequency.

AmpSentry™ Protection includes an overload signal that can be used in conjunction with transfer switches or Master Controls to automatically shed load, preventing a potential genset Shutdown. The overload signal is programmable for operation at a specific kW level, on the basis of an under frequency condition.

AmpSentry™ Protection for paralleling also includes protection for genset reverse power, loss of excitation, alternator phase rotation and circuit breaker failure to close. It includes permissive (synchronising check) functions for automatic and manual breaker closure operations.

3.15.1 Commonly Asked Questions About AmpSentry™ Control Systems

1. Does the generator FL current monitored change within PCCP for voltage settings?

Yes! The control system uses the genset kW rating and voltage to calculate rated current and reset the position of the protection curve within the control system. The control system will use the highest current found on any phase as a basis for the over current actions taken by the control.

2. When the set is selected and entered into PCCP along with the voltage, how is the trip curve changed to accommodate the current which is derived from the kVA and voltage?

The actual algorithms and operating system that we use to get to the trip performance shown on R1053 are proprietary. However, you can think of the protection as operating in a similar fashion to that shown on the protection curve. Protection on various units within an alternator family is performed as a function of multiples of the steady state current rating. So, as the current rating changes, the curve automatically shifts to compensate for it.

3. For a given over load current would you expect the alarm position to be given on the R1053 curve or in some place to the left of the curve?

The over current pre-alarm point is fixed at 110% and 60 seconds. The Shutdown point is defined by the curve shown on R1053. The genset will **Shutdown at the point shown on the curve**, with the only deviations to this due to the calibration and/or accuracy of the CTs driving the system. Note that the CTs are selected to allow them to not saturate at five times rated current, so that they can provide accurate readings when the system is running in an over current condition. Note also that the algorithms in the control have integrating functions which result in the control reducing the time to trip if you have consecutive faults applied to the system. To completely reset the control you would need to wait for at least six minutes before another fault or test was commenced in order to get an accurate reading of trip time on a specific event.

4. For a 175% and above current would you expect to see the trip point on the curve or to the left of the curve? I assume these levels are closer to the curve.

Again, I would expect the unit to trip at the point shown on the curve, not to the right or left of it.

5. Why is the horizontal trip area starting at 4 x FLI when the genset only manages 3 X FLI as a maintained current?

The protection curve was drawn based on the thermal capabilities of the alternator, not the ability of the alternator to produce current. We purposely drew the protection curve as close to the damage curve as practical, to minimise the possibility of nuisance tripping, and facilitate discrimination with downstream devices. The curve goes horizontal at the point shown because it is the point of maximum output current for the alternator, and to continue dropping the curve would have no meaning or purpose.

6. Is the 3 x FLI maintained current relative to set output rating or alternator rating? If it is alternator rating, then which alternator frame size is it set for, again, I assume the smallest machine for the genset model?

The 3 X current is based on the genset rating, not the alternator rating. Therefore when you have an alternator that is running at lower than rated temperature rise (such as running a class H machine at 105°C rise) based on the genset KW rating the protection curve is a bit conservative, but it always works to protect the machine.

It is worth noting that another significant difference between PCCP and other control systems is that PCCP **measures and regulates** fault current. In other systems, the voltage regulator will switch to full field operation on a fault, and the magnitude of fault current that you actually get is determined by the physical capabilities of the machine. Consequently, in non-PCCP machines it is not uncommon for the value of fault current provided to be somewhat more or less than the 300% level which is commonly specified. With PCCP, you will get 300%, because the output of the system is regulated to that level, in a very similar fashion to the way that voltage is regulated on normal operation conditions.

7. For single phase faults, does the time get multiplied up for the extra heating effect such a fault has on the alternator?

No! Prototype testing that we did on the system, which included applying bolted faults to machines and measuring temperature rise in the alternators, did not indicate a need to modify the over current algorithms for single phase operation.

8. What happens when the set is de-rated and the output drops? I assume here that protection carries on for the 40°C rated product ratings.

When you go to de-rate the genset for altitude or temperature, we don't move the protection curve, so the situation is similar to that noted in question number seven above - the protection gets more conservative. However, if you actually plot the differences on the curve, you will see that there is not a very significant impact in the location of the damage curve and the protection provided by the control.

9. The customer requires to set the distribution breakers to enable them to discriminate with the genset controller, particularly on faults.

I don't see how the AmpSentry™ protection could get into the way of discrimination with downstream devices. The curve is literally hugging the damage curve for the alternator in most cases, so if the downstream device did not co-ordinate with the damage curve, you undoubtedly would be getting to the point where without AmpSentry™ you could damage the machine.

Note that most of the problems of discrimination revolve around interference in the instantaneous region of the breaker curves. Since the AmpSentry™ curve goes horizontal at 0.6 seconds, and most breakers have instantaneous set at around 0.05 seconds max, there is a lot of room for discrimination that you can't get in any other way. Even if the downstream breakers have long time ratings as long as 30 cycles, PCCP will allow discrimination between PCCP and the first downstream device(s).

If you have a specific situation, which is apparently a problem, I would be happy to look it over and offer suggestions. Perhaps I do not clearly understand the problem that the customer is seeing.

10. We do not show or display anywhere what our settings are. They are not visible on the genset control.

We do provide R1053 to describe the performance of the over current protection system, and allow customers and designers to verify system co-ordination. Unlike circuit breaker applications where a single protective device may be applied to many different situations, we have the luxury of only having to protect our machines, so there is no real need for adjustment in the over current protection and a single protective function curve can always be used to describe performance. We have tested the control system with actual short circuits of varying magnitude on real gensets, and also with current injection tests witnessed by third party authorities and proved that the control system functions as shown on our documentation. Since we are talking about processor-based control here, it's practically impossible that the control would fail to function properly, unless the inputs to the control are not performing properly. (In other words, the CTs are not properly calibrated, or are not working right due to improper sizing, etc.) Also, there are some cumulative functions in the control that result in faster tripping under conditions where repeated faults hit the control.

11. Does every customer test the current trips and plot his curve to know where he is?

No! The customer is best served by using our curves.

12. Are you saying the curve is reliable and he does not need to test? If you are, then supportive data is needed for each control to present to the customer showing the performance against the output conditions.

Yes, the curve is a reliable depiction of actual unit operation. We are proceeding with third party certification of the performance of the control system as part of our effort to get UL2200 listing of the product. At that point testing at your site to verify performance should be superfluous. Since the protective functions are adequately described by R1053, I really don't understand what else we could provide that would be more useful for specific situations.

13. Reverse power. How does PCCP calculate rev pwr?

For reverse power calculations, the control will add together the power level seen on each phase. So, if you only use one phase, it will logically take three times the expected level of current to get to tripping time. This, of course, assumes that you are also driving appropriate power factor, because the control actually calculates kW, and that requires power factor measurement and calculations.

This is one function that is easy to test in the control, because by simply reversing the CT wiring you can make the control think that positive power output is reverse power. So, in the future, when you test for reverse power, I'd suggest that you use that means rather than a current injection test.

Standard AmpSentry™ settings

Condition	Action	Notes
Over Volts	Shutdown	At 130% of nominal or 110% for ten seconds
Under Volts	Shutdown	85% of Nominal for ten seconds
Over Freq	Shutdown	115% of nominal speed +/- 1%
Under Freq	Shutdown	90% of nominal for ten seconds, five seconds before shutdown a load dump signal is outputted to avoid shutdown if load shed is available
Rev Pwr	Shutdown	10% of nominal rating. Can be set up via a security code given to service distributors
Exciter Loss	Shutdown	Monitored excitation output is either wrongly set or has failed

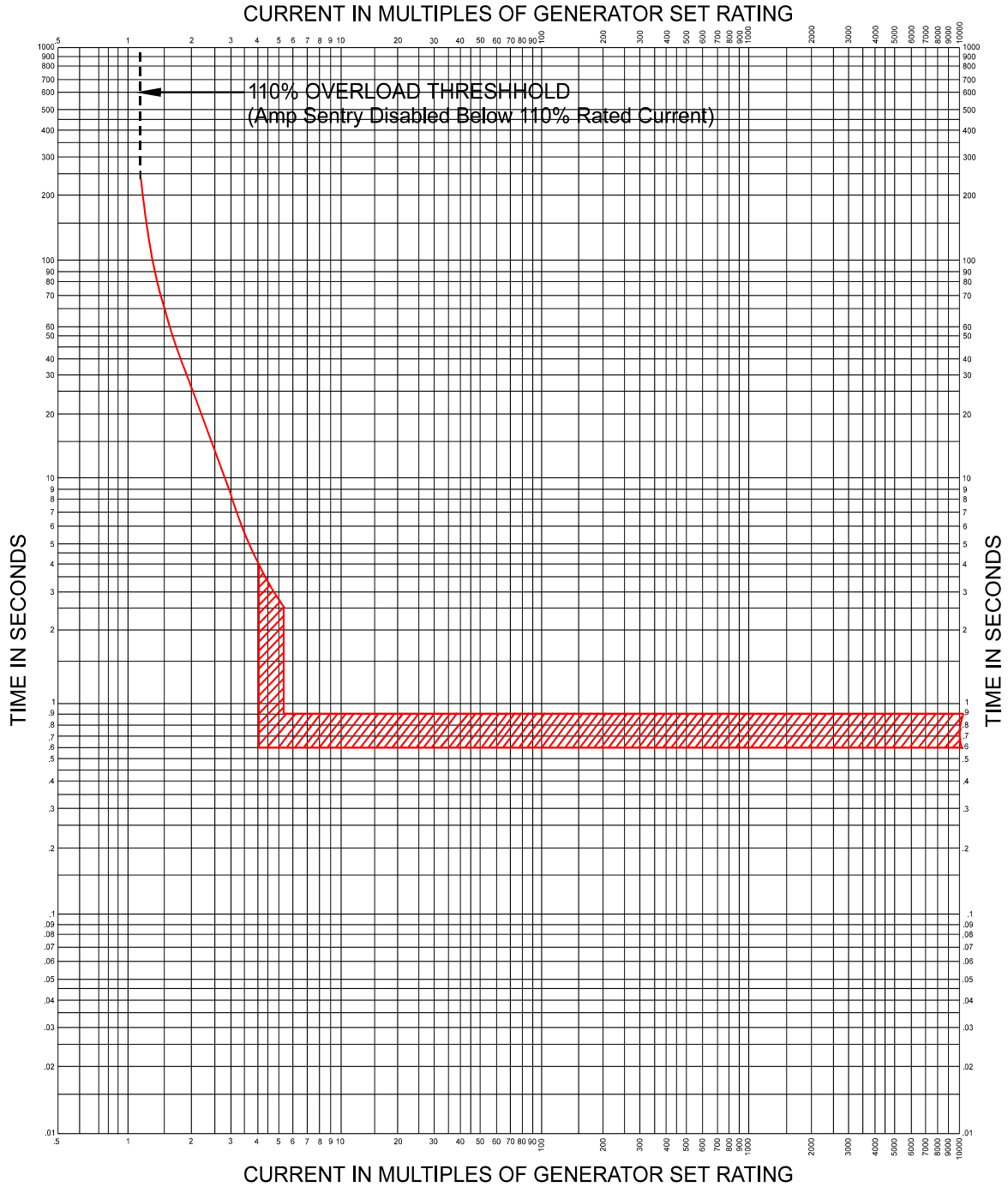

**Cummins
Power
Generation**

**PowerCommand™ Control Amp Sentry™
Time-Over-Current Characteristic Curve**

Note: This curve is applicable to
all Power Command Generator sets

R-1053

Figure 3-3 Time-over Current Curve

SECTION 4 – CONTROL SYSTEM

4 Control System

4.1 Control System Description

The main control panel and its associated equipment are located in the Control Housing, which is mounted on the bedframe at the rear of the genset. A Load Terminal Box will be mounted on either the left or right side of the housing, as required for the site.

The PCCP is a microprocessor-based control for gensets. It provides fuel control and engine speed governing, main alternator voltage output regulation, and complete genset control and monitoring. It also provides controls for automatic and semi-automatic synchronising and automatic load sharing for both isolated bus and utility (mains) paralleling applications. The control also monitors the health of the engine, alternator and auxiliary systems continuously, and will affect an Automatic Shutdown if a serious fault occurs. All indicators, control switches/buttons and alphanumeric display are located on the face of the control panel as illustrated in Figure 4-1.

The PCCP operates in conjunction with an array of sensors and senders located on the engine, alternator and auxiliary systems. Data is passed between components over a digital data link.

An important function of the control system is to continuously monitor the genset for faults. If a fault occurs during engine running, the PCCP will provide an indication for the operator and, if the fault is serious, affect an automatic, fully programmed, Shutdown. One of three fault level signals will be generated by the PCCP. The three fault levels are:

1. **Warning**, signals an imminent or non-fatal engine fault. The PCCP provides an indication only for this condition.
2. **Fault**, signals a potentially damaging condition. The PCCP will automatically subject the engine to an off-load, cool-down run, and will then shut it down.
3. **Shutdown**, signals a potentially fatal fault for the engine. The PCCP will automatically take the engine off-load and shut it down immediately, without a cool-down run.

The control systems operate on 12 or 24VDC battery power. Data backup is taken care of by a small rechargeable battery installed within the PCCP enclosure. Auxiliary equipment operates on LV AC power.

4.1.1 Control Mode Definitions

The following Control Mode Definitions are used in this manual:

Control Mode	Definition	Initiating Condition / Reset	Generator Load
Normal Stop	A stop initiated manually during normal genset running.	Stop with PCCP STOP switch. Manually reset any alarm at PCCP before restart.	Auto ramping down of load before stopping.
Alarm	Alarm condition with alarm indication / horn / beacon.	Non critical alarm condition. Alarm reset at PCCP.	Loading maintained.
Controlled Shutdown	Alarm condition with alarm indication / horn / beacon.	Alarm requiring controlled engine stop. Switch off & manually reset at PCCP before restart.	Auto ramping down of load.
Immediate Shutdown	Critical alarm condition with immediate engine stop alarm indication / horn / beacon.	Critical alarm condition. Switch off & manually reset at PCCP before restart.	All of load dumped with immediate engine shutdown.
Lockout	Engine inhibited from starting with alarm indication/horn/beacon.	Start inhibit due to critical fault condition. Reset at PCCP when alarm condition is clear.	Load previously removed. Engine stopped.

Table 4-1 Control Mode Definitions

4.1.2 Control Panel Power ON/OFF Modes

The power On/Off modes of the control panel and operating software are Standby Mode and Power On Mode.

Standby Mode

In the Standby (sleep) Mode, (selector switch S5, located on a printed circuit board inside the PCC, is set to the right and the genset is not running), the control's operating software is inactive and the LEDs and displays on the front panel are all off. The panel appears to be dead.

The operating software is initialised and the front panel automatically reactivated in response to a run signal or any one of eight wake up signals from remote sensing switches. The wake up signals are:

- Emergency Stop
- Low Coolant Level
- Low Coolant Temperature
- Low Fuel
- Customer Fault Inputs 2 and 3
- Run Selected on Mode Switch
- Remote Start Signal in Auto Mode
- Self-test membrane switch operation

To activate and view the menu displays, press and release the Self Test switch. The PCCP will initialise the operating software and permit operation of the menu display panel. If no menu selections are made, the power to the control panel will shut down after 30 seconds.

Power On Mode

In the Power On (awake) Mode, (selector switch S5 is set to the left), the PCCP initialises the operating software and activates the menu display panel continuously. It is recommended that switch S5 be left in the Power On Mode, unless battery charging is not available.

<p>Caution: <i>Electrostatic discharge will damage circuit boards. To prevent this damage, always wear a grounding wrist strap when touching or handling either circuit boards or socket-mounted ICs, and also when disconnecting or connecting harness connectors.</i></p>
--

4.1.3 Control Panel – Front Panel

The main control panel for the genset forms the front panel of a PowerCommand®Control (Paralleling) enclosure.

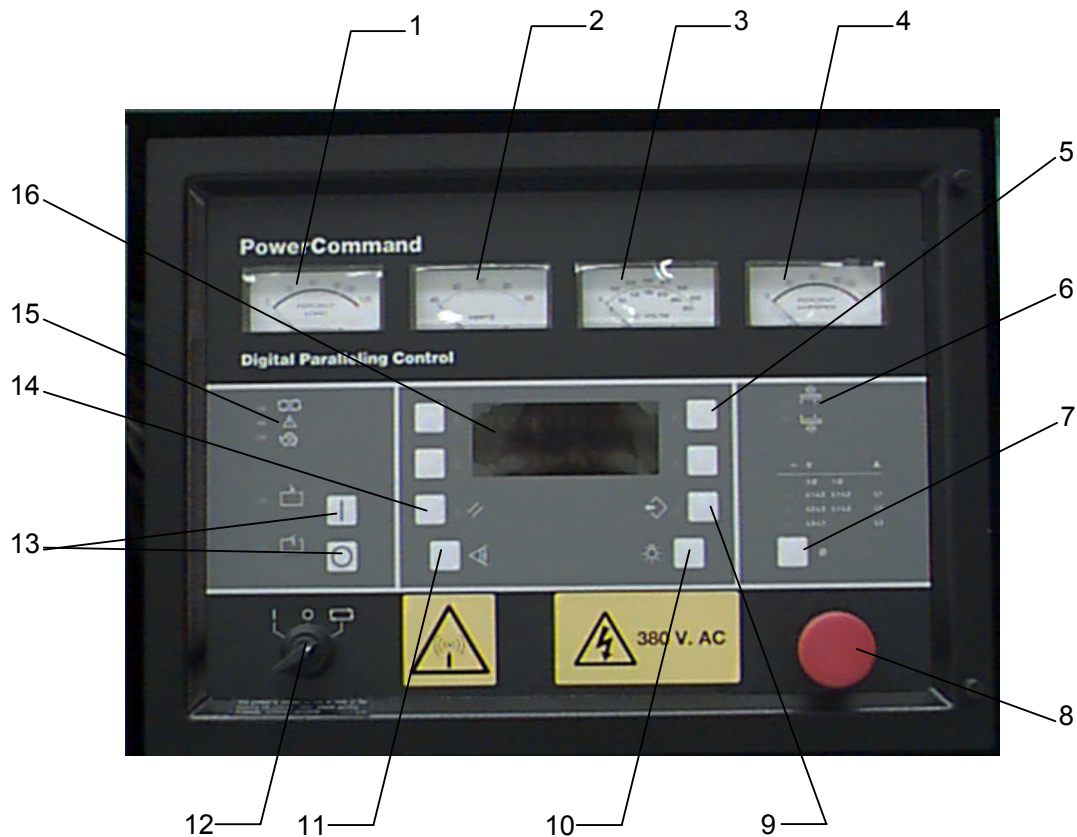

Figure 4-1

Front Panel

- | | |
|---------------------------------------|---|
| 1. % Kilowatt Meter | 10. Panel Lights Switch |
| 2. Frequency Meter | 11. Self-test Switch |
| 3. AC Voltmeter | 12. Run / Off / Auto Switch (Mode switch)
(This may be a Key Switch) |
| 4. % AC Ammeter | 13. Breaker Control Push- buttons |
| 5. System Control Selection Switches | 14. Reset Switches |
| 6. Voltage Meter Scale Indicator Lamp | 15. Status Indicators |
| 7. Phase Selector Switch + Indicators | 16. Digital Display & Status Panel |
| 8. Emergency Stop Switch | |
| 9. Menu "Home" Switch | |

4.1.4 Control Panel Switches and Indicators.

- 1) **Kilowatt Meter:** — Indicates 3-phase AC power output as percent of rated load.

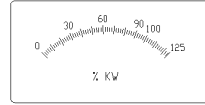

- 2) **Frequency Meter:** — Indicates generator output frequency in Hz.



- 3) **AC Voltmeter:** — Dual scale instrument, which indicates AC voltage. Measurement scale is shown on scale indicator lamp.

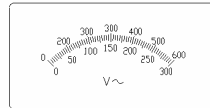

- 4) **AC Ammeter:** — Indicates current output in percent of maximum rated output (percent current is based on 0.8 Power Factor).

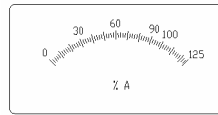

- 5) **System Control Selection Switches:** — Four membrane switches - two on each side of the alphanumeric display window - are used to step through the various menu options and to adjust genset parameters. The green arrow on the alphanumeric display adjacent to the switch is lit when the switch can be used (switch is active).

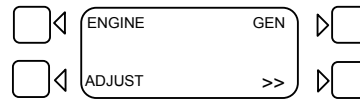

- 6) **Voltage Meter Scale Indicator Lamps:** — Indicate AC Voltmeter scale selected.

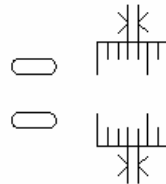

- 7) **Phase Selector Switch and Indicators:** — Press this momentary switch to select phases of generator output to be measured by the analogue AC Voltmeter and Ammeter. LEDs indicate the selected phase.

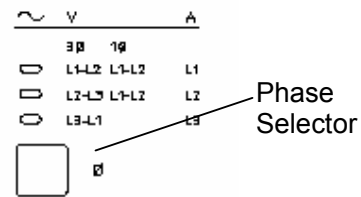

- 8) **Emergency Stop Push-switch:** — Push the switch for an emergency shutdown of the engine. To reset at the PCCP:
- Pull, or pull and twist, the Emergency Stop to unlatch it
 - Move the Mode switch to Off
 - Press the Reset membrane switch
 - Select Run or Auto, as required

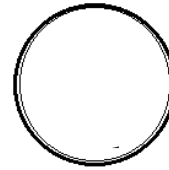

- 9) **Menu Home Switch:** — At any time, press this membrane switch to return the alphanumeric display to the Main Menu. Refer to the menu trees later in this section.

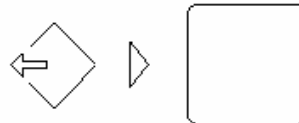

- 10) **Panel Lights Switch:** — Press this membrane switch to turn control panel illumination on and off. The illumination will shut off automatically after approximately eight minutes to save battery power.

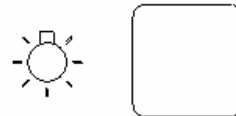

- 11) **Self-test Switch:** — Press and hold this membrane switch to light all front panel LEDs and cycle through all shutdown and warning messages.

In the Standby (sleep) mode, (with the genset not running) the control's operating software is inactive and the LEDs and displays on the front panel are all deactivated.

To activate and view the menu displays without starting the genset, press and hold the Self-Test switch until the front panel LEDs are lit. The PCCP will initialise the operating software and reactivate the menu display panel. If no menu selections are made, a software timer will shut down the display after 30 seconds.



12) **Run / Off / Auto Switch (Mode Switch):**

— This switch starts and stops the genset locally, or enables start / stop control of the engine from a remote location. (Ground to start.)

An optional key function may be provided to prevent unauthorised operation of the switch.

Off - de-energises all primary DC circuits, preventing genset operation. When the switch is in this position, a Non-Automatic indicator LED will flash continuously.

Run - energises the control system and initiates genset starting and operation. The breaker control switches are enabled only in the Run position. The Non-Automatic indicator will flash when the switch is in the Run position, indicating that the paralleling breaker will not automatically close.

Auto - enables the control system to receive a start signal from a remote location. This will energise the control system, initiating the genset starting and operation sequences.

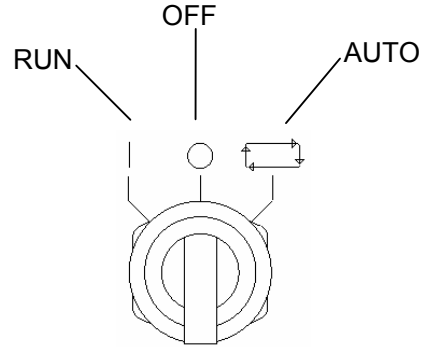

13) **Breaker Control Push buttons:**

—These push button controls are used to manually control the opening and closing of the generator paralleling breaker when in the Run mode. The breaker close operation is operated through a permissive function (with dead bus logic) to prevent accidental out of phase paralleling of the genset to the system bus.

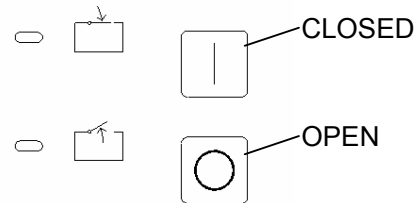

14) **Reset Switch:**

— Press this membrane switch to reset Warning and Shutdown messages after the condition has been corrected. To reset a Shutdown message with the Reset switch, the Mode switch must be in the Off position. With the Mode switch in the Auto mode, shutdown faults can be reset by removing the start input and then cycling the remote reset input.

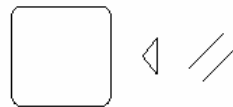

15) **Status Indicators:** —

Non-Automatic This red lamp flashes continuously when the Run/Off/Auto switch is not in the Auto position.

Warning This yellow lamp is lit to indicate that a condition outside the desired parameters has occurred. The reset switch is used to clear this message when the Warning condition has been corrected. (It is not necessary to stop the genset). With the Run/Off/Auto switch in the Auto mode, warnings can also be reset by cycling the remote reset input after the condition is corrected

Shutdown This red lamp illuminates when a Shutdown condition has occurred. After the condition has been corrected, shutdown indicators can be reset by turning the Run/Off/Auto switch to the Off position, and pressing the reset switch. In Auto mode, shutdowns can be reset by removing the remote start input and then cycling the remote reset input.

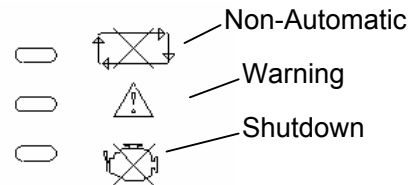

16) **Alphanumeric Display and Status Panel:** — This two-line 16-character per line digital display is used in the menu-driven operating system, in conjunction with the Menu Selection switches and the Menu switch. Refer to the menu trees later in this manual. The display is also used to show Warning and Shutdown messages.

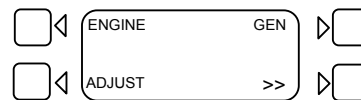

4.2 Menu Display and Switches

Figure 4-2 shows the alphanumeric display and menu selection switches.

4.2.1 Alphanumeric Display and Switches

The illustration shows the PCCP's alphanumeric display and the menu selection membrane switches. Refer to section 4.1.3 Front Panel, which describes the display and all the switches.

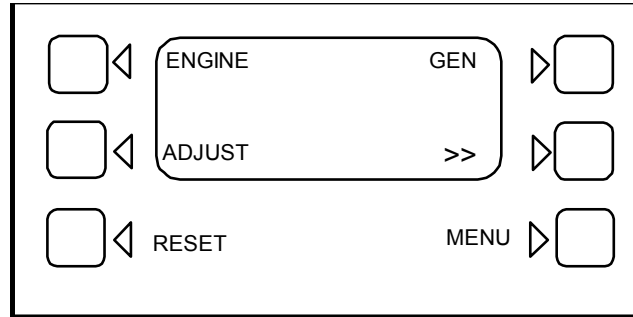

Figure 4-2 Alphanumeric Display and Switches

In the Standby (sleep) Mode, to activate and view the menu displays without starting the genset, press and release the Self-Test membrane switch (see Front Panel illustration). This will initialise the PCCP operating software and permit operation of the menu display panel. If no menu selections are made, a software timer will shutdown the display after 30 seconds.

In the Power On (awake) Mode, power is continuously supplied to the control panel and the alphanumeric display will remain on.

Note: *In the alphanumeric display, the >> symbol indicates that selecting the adjacent membrane switch causes the operating program to branch to the next menu display as shown in the menu diagrams.*

Note: *The << symbol indicates that selecting the adjacent membrane switch causes the operating program to return to the previous menu displayed.*

4.2.2 Main Menu

The facing page shows the Main Menu and a block representation of the menu tree, including all available sub-menus. Initially the alphanumeric display shows the titles in the central block (i.e. Engine, Gen, Adjust, >>). Pressing a membrane switch next to a title displays the next indication in the tree.

As shown in the diagram, the Main Menu can branch into one of four directions:

1. **Engine:** To display engine parameters, such as oil pressure and temperature, water temperature, engine speed (RPM), and exhaust temperature, press the membrane switch next to the word Engine in the display. Refer to Engine menu in this section.
2. **Gen:** To display generator parameters, such as volts, amps, power (kW), and frequency, press the membrane switch next to the word Gen in the display. Bus voltage, frequency and a digital synchroscope can also be viewed from this menu branch. Refer to Gen menu in this section.
3. **Adjust:** To adjust output voltage and frequency, or start and stop delays, press the membrane switch next to the word Adjust in the display. Refer to Adjust menu in this section.
4. **>> (version):** To display the selected genset model and the resident version software, press the membrane switch next to the >> in the display. From this selection, you can also review a History file that can record and save up to twenty error messages. Refer to Version menu in this section.

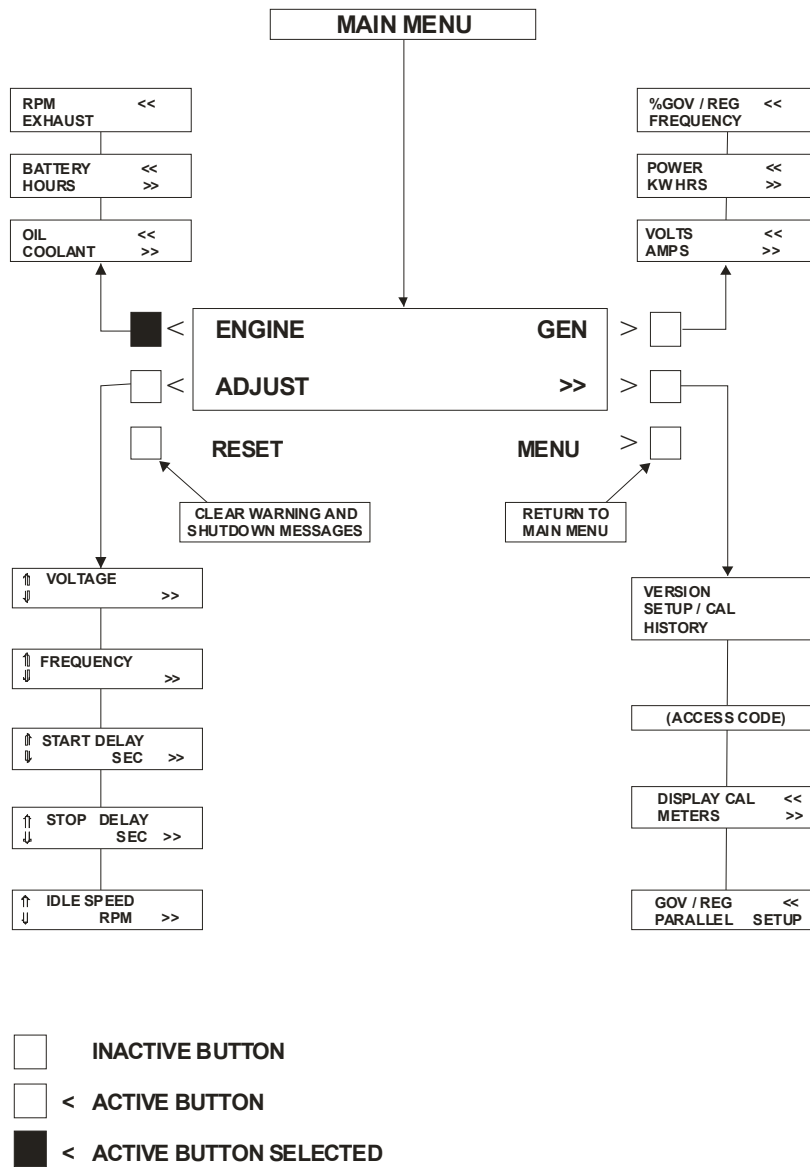

Figure 4-3 Main Menu

4.2.3 Engine Menu

The facing page shows a block representation of the Engine menu tree, including all available sub-menus. Pressing the membrane switch next to the word Engine in the display introduces the first Engine sub-menu.

As shown in the diagram, the Engine menu has three sub-menus:

1. **Oil / Coolant sub-menu:** This is the first sub-menu. Select Oil for a display of oil pressure and oil temperature. Select Coolant for a display of coolant temperature. When oil or coolant parameters are displayed, pressing the membrane switch next to the << will return the display (Back) to the Oil Coolant sub-menu.
2. **Battery / Hours sub-menu:** From the Oil Coolant sub-menu, press the membrane switch next to the >> in the display to move to the Battery / Hours sub-menu. Select Battery for a display of battery voltage. Select Hours for a display of the number of starts and the running hours. When battery or hours parameters are displayed, pressing the membrane switch next to the << will return the display (Back) to the Battery / Hours sub-menu.
3. **RPM / Exhaust sub-menu:** From the Battery / Hours sub-menu, press the membrane switch next to the >> in the display to move to the RPM / Exhaust sub-menu. Select RPM for a display of engine RPM. Select Exhaust for a display of the (optional) exhaust temperature. When RPM or exhaust parameters are displayed, pressing the membrane switch next to the << will return the display (Back) to the RPM / Exhaust sub-menu.

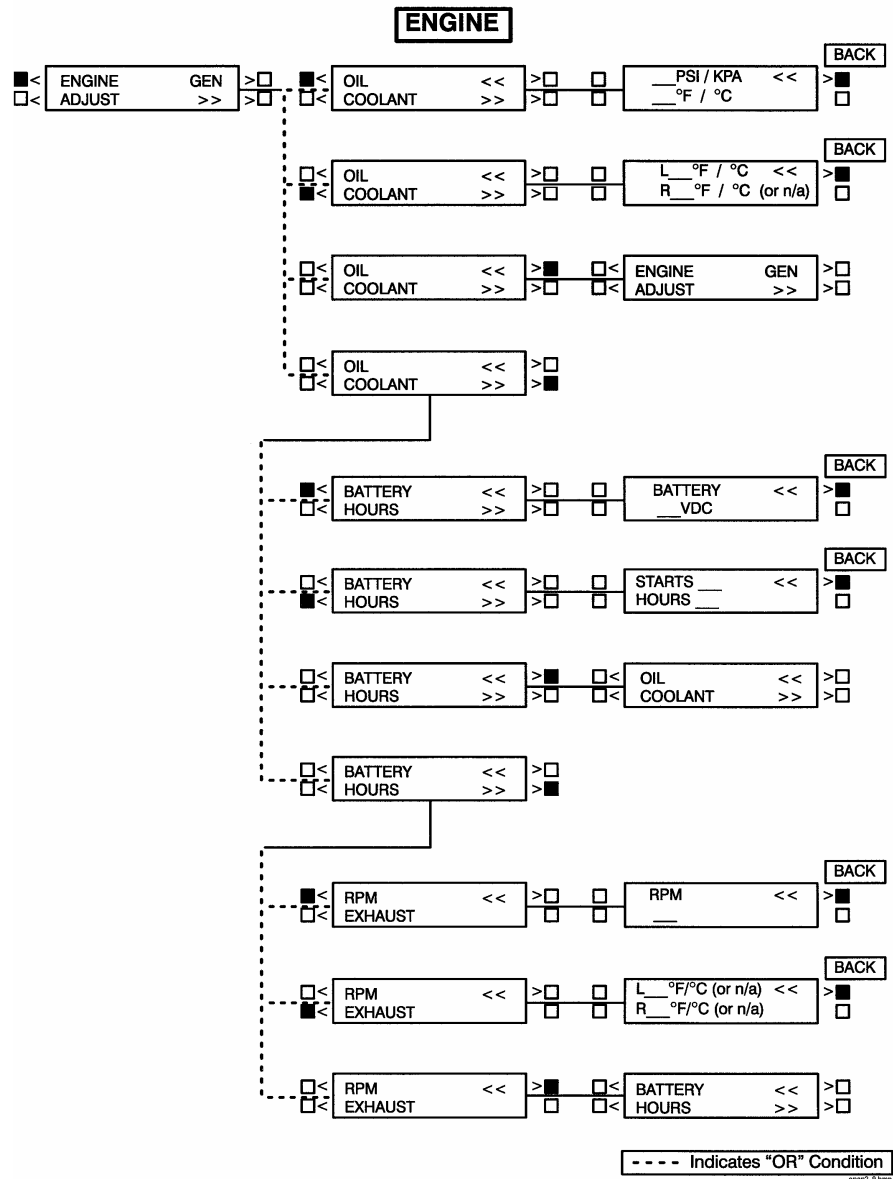

Figure 4-4 Engine Menu

4.2.4 Gen Menu

The facing page shows a block representation of the Gen (generator) menu tree, including all available sub-menus. Pressing the membrane switch next to the word Gen in the display introduces the first Gen sub-menu.

As shown in the diagram, the Gen menu has three sub-menus:

1. **Volts / Amps sub-menu:** This is the first sub-menu. Select Volts for a display of a line-to-line or line-to-neutral selection, or for viewing of the system bus line-to-line voltage. Select line-line or line-neutral for the desired voltage display. Select Amps for a display of L1, L2, and L3 current in amps. When voltage or current parameters are displayed, pressing the membrane switch next to the << will return the display (Back) to the L-L / L-N sub-menu.

Note: *If Delta is selected in the Initial Start Set-up sub-menu when selecting Volts, the line-line or line-neutral sub-menus will not be displayed. Only the L12, L23, L31 sub-menu will be displayed.*

2. **Power / kW Hours sub-menu:** From the Volts / Amps sub-menu, press the membrane switch next to the >> in the display to move to the Power / kW Hours sub-menu. Select Power for a display of power output in kilowatts and a power factor value. Select kW Hours for a display of kilowatt-hours. When Power or kW Hours parameters are displayed, pressing the membrane switch next to the << will return the display (Back) to the Power / kW Hours sub-menu.

Note: *The PF reading will contain an asterisk if the power factor is leading (for example, *.3PF).*

Note: *Beginning at PCC Version 1.06, N/A is displayed in the PF field when the genset is not running.*

3. **% Gov / Reg / Frequency sub-menu:** From the Power/ kW Hours sub-menu, press the membrane switch next to the >> in the display to move to the % Gov / Reg / Frequency sub-menu. Select % Gov / Reg for a display of voltage regulator and governor duty cycle (drive) levels in percentage of maximum. Select Frequency for a display of the generator output frequency, the bus frequency, or the digital synchroscope. When voltage regulator and governor or frequency parameters are displayed, pressing the membrane switch next to the << will return the display (Back) to the % Gov / Reg / Frequency sub-menu.

Bus Frequency (Digital Synchroscope) sub-menu: When the bus frequency (digital synchroscope) information is displayed, the operator can observe the genset synchronising with the system bus. The display indicates bus frequency and number of degrees from synchronous condition (+ indicates faster, - indicates slower). When the genset is operating within the sync-check window, an asterisk will indicate that the paralleling breaker can be closed.

When — — — is displayed, the synchroniser is not active.

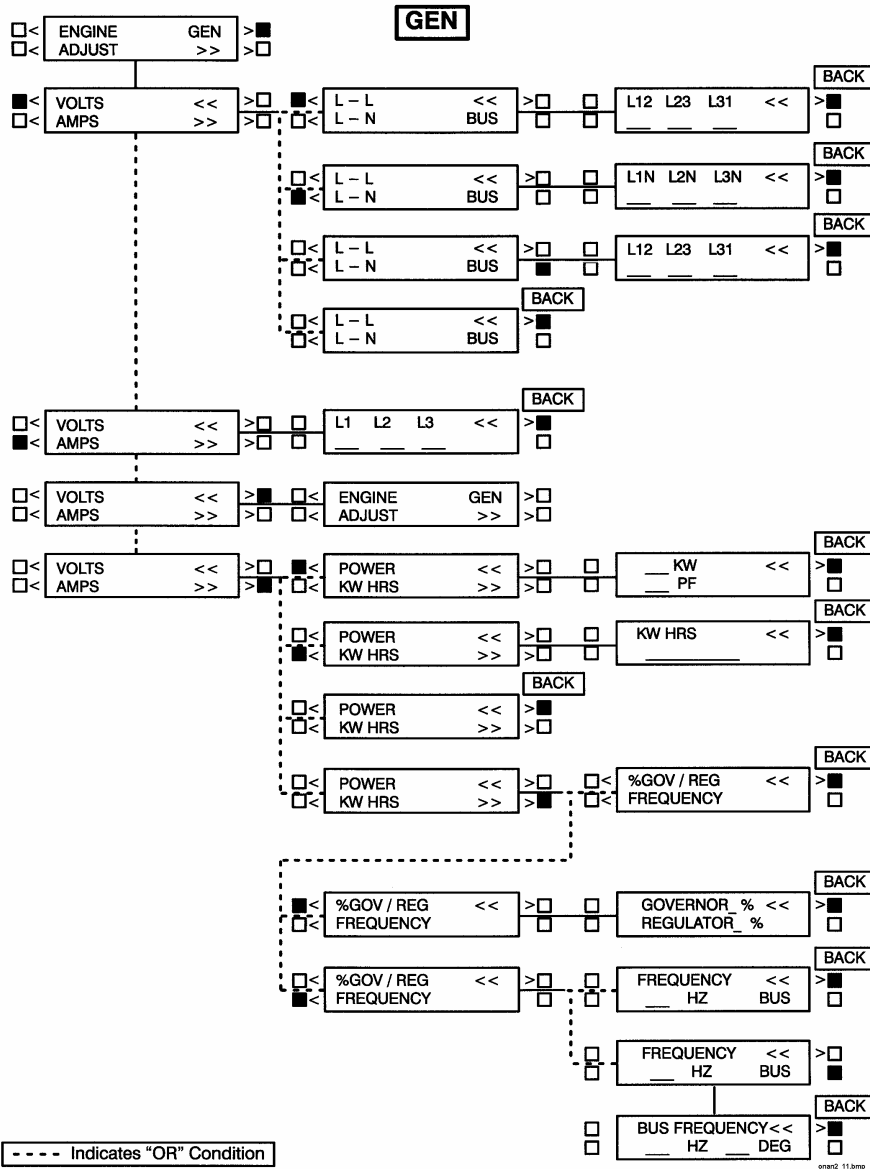

Figure 4-5 Gen Menu

4.2.5 Adjust Menu

The facing page shows a block representation of the Adjust menu. If you press the button next to the word Adjust in the display, the Voltage Adjust sub-menu will appear.

As shown in the diagram, the Adjust menu has six sub-menus, including a save / exit procedure.

Voltage and frequency can be adjusted only when the genset is running under normal operating parameters (not in idle mode). For example, if voltage adjustment is selected when the set is in Idle mode or not running, the alphanumeric display will be:

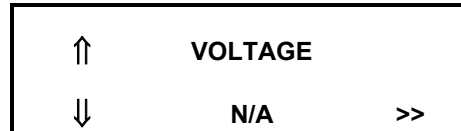

1. **Voltage sub-menu:** This is the first sub-menu. Use the buttons next to the ↑↑ and ↓↓ symbols to adjust output voltage $\pm 5\%$.
2. **Frequency sub-menu:** From the Voltage sub-menu, press the button next to the >> in the display to move to the Frequency sub-menu. Use the buttons next to the ↑↑ and ↓↓ symbols to adjust output frequency $\pm 5\%$.
3. **Start Delay sub-menu:** This delay applies only to remote starting in the Auto mode. From the Frequency sub-menu, press the button next to the >> in the display to move to the Start Delay sub-menu. Use the buttons next to the ↑↑ and ↓↓ symbols to set the start delay. The start delay adjustment range is 0 to 300 seconds.
4. **Stop Delay sub-menu:** This delay applies only to remote stopping in the Auto mode. From the Start Delay sub-menu, press the button next to the >> in the display to move to the Stop Delay sub-menu. Use the buttons next to the ↑↑ and ↓↓ symbols to set the stop delay. The stop delay adjustment range is 0 to 600 seconds.
5. **Idle Speed sub-menu:** From the Stop Delay sub-menu, press the button next to the >> in the display to move to the Idle Speed sub-menu. Use the buttons next to the ↑↑ and ↓↓ symbols to set the idle speed. The idle speed adjustment range is 800 RPM ± 100 RPM (Default value is 800 RPM). The idle speed can be adjusted only when the genset is running in the Idle mode. When not in Idle mode, N/A is displayed in the RPM field.

Note: *The Idle Speed sub-menu will not be used for gensets that do not require their speed to be reduced to idle before shutting down. Under this circumstance only the Stop Delay sub menu is used to initiate a cooling run before shutting down the genset.*

6. **Save/Exit sub-menu:** From the Stop Delay sub-menu, press the button next to the >> in the display to move to the Save/Exit sub-menu. Select Save to save your changes. At the Changes Saved sub-menu, select Exit to return to the main menu.

If you select Save, the adjustments will be retained after shutdown, and will be in effect when the set is restarted. If you select Exit without saving first, the adjustments will remain in effect until the genset is shut down, but will be reset (and will not be in effect) when the set is restarted.

ADJUST MENU

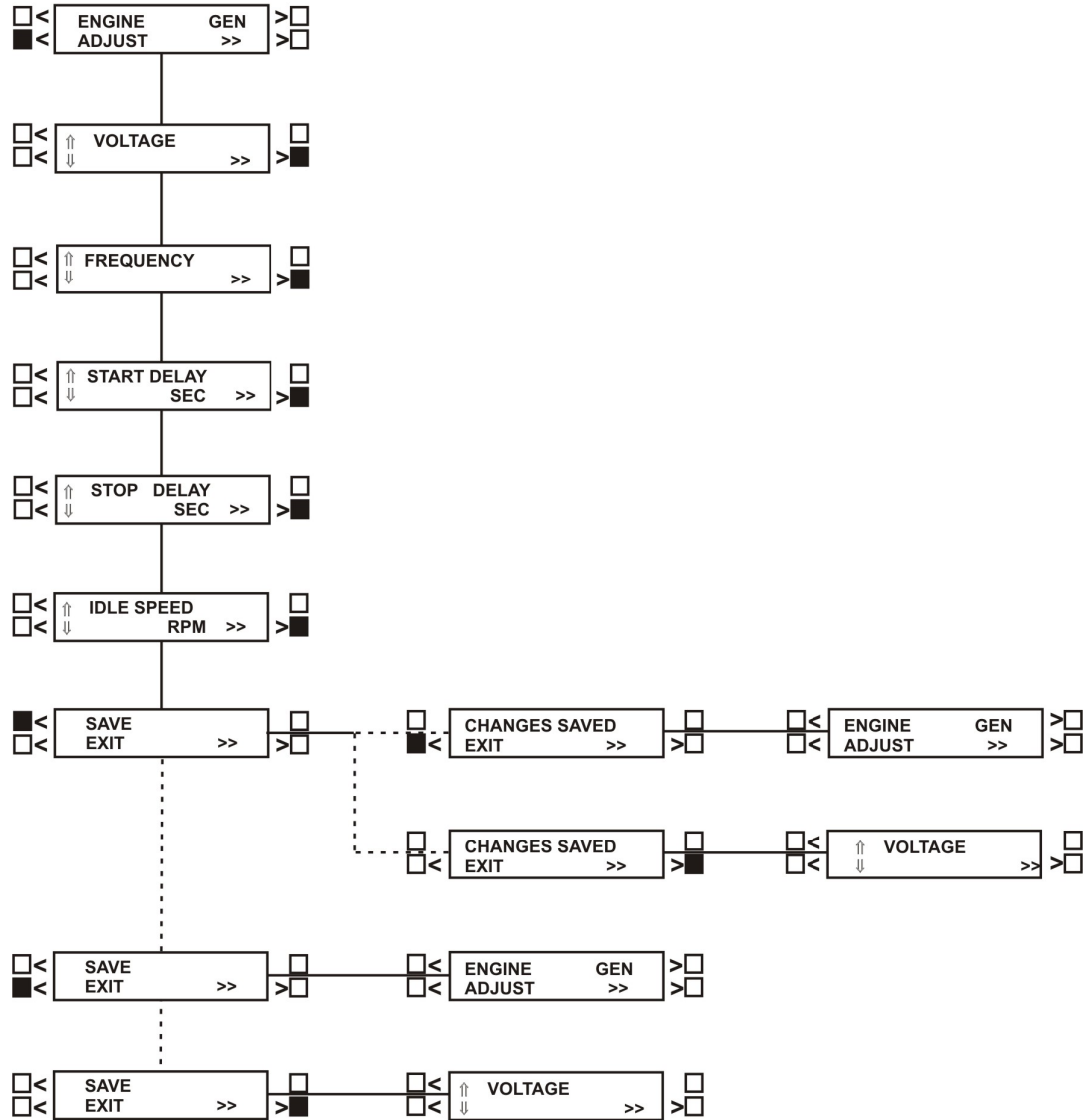

- - - - Indicates 'OR' Condition

Figure 4-6 Adjust Menu

4.2.6 Version Menu

The facing page shows a block representation of the Version sub-menus. If you press the button next to the >> in the Main menu display, the Version/Set-Up/Cal menu will appear.

Note: *It is intended that qualified service personnel only should modify any of these entries, and it is therefore necessary to enter the access code before proceeding. (Refer to the Service manual).*

Version sub-menu: If you select Version, the display will show the genset model number, frequency and kW rating, and the date and version of the operating software.

To display the genset configuration options, press the button next to the >> in the sub-menu that displays the model number, frequency, etc. This menu provides the following information:

- Genset voltage
- Wye (i.e., Star) or Delta and Full or Standard
- Standby or Prime
- Single or Parallel

History: From the Version menu, press the button next to the >> in the display to move to the History sub-menu. Press the button next to History to display the last (latest) recorded error message.

The software will record (i.e. save) up to twenty error messages. The last error detected will always be displayed first. As each new error is detected, the oldest error recorded after twenty will be deleted.

To view the genset runtime at which the error occurred and to scroll through the remaining recorded errors, press the button next to the >> in the error message menu to display the Runtime, Newer/Older menu.

The buttons next to Newer and Older are used to scroll up and down through the error messages. For example, pressing Older will display the next oldest recorded error message. When pressing Newer the last (newest) error message will be displayed, the display will return to the History menu.

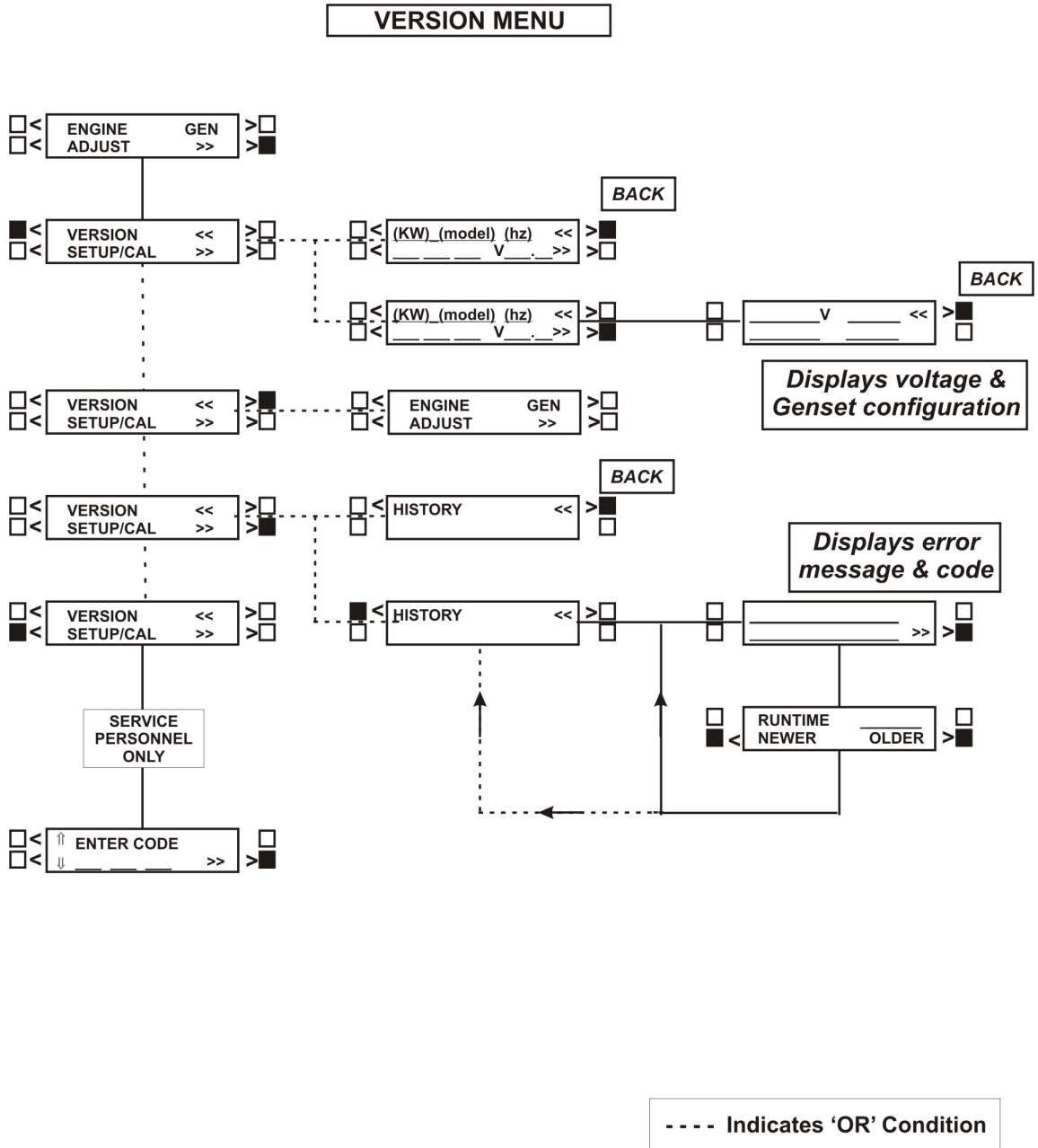

Figure 4-7 Version Menu

SECTION 5 – SYSTEM OPERATION

5 Operation

5.1 Safety

Only suitably qualified and experienced personnel should carry out genset operations. Before operating the system, the operator should become familiar with Section 1 of this manual – Preliminary and Safety instructions, together with the Health and Safety Manual (3553). Observe all of the WARNINGS and CAUTIONS at all times.

WARNING: BEFORE OPERATING THE PLANT BECOME FAMILIAR WITH THE EQUIPMENT AND HOW IT IS OPERATED (INCLUDING ALL CONTROLS, MANUALLY OPERATED VALVES AND ALARM DEVICES). SAFE AND EFFICIENT OPERATION CAN ONLY BE ACHIEVED IF THE PLANT IS OPERATED CORRECTLY.

WARNING: CONTACTING HIGH VOLTAGE COMPONENTS CAN CAUSE SEVERE PERSONAL INJURY, OR DEATH BY ELECTROCUTION. DO NOT OPEN THE GENERATOR OUTPUT BOX WHILE THE GENSET IS RUNNING. READ AND OBSERVE ALL WARNINGS AND CAUTIONS IN YOUR GENSET MANUALS.

Caution: *Only technically qualified personnel should open the PCCP front panel. Voltages are present in the PCCP, which can cause electrical shock, resulting in personal injury. Even with power removed, improper handling of components can cause electrostatic discharge and damage circuit board components.*

5.2 Introduction

This section describes the operation of the genset, covering pre-start checks, starting and stopping, and operating the genset. The sequences that occur during generator Start-up and Running; Normal and Emergency Stop procedures; Alarm and Shutdown procedures, and controls are also described. The text should be read in conjunction with the System Description, Control System Operation, and the Engine and Alternator Operating Manuals.

All indicators, control switches/buttons and digital display are located on the face of the control panel as illustrated in Figure 4-1.

5.3 Maintenance

To secure maximum performance and reliability from your genset it is essential that certain components are inspected periodically and, where necessary, maintenance procedures carried out as detailed in Section 6 - Maintenance.

5.4 Operating Recommendations

5.4.1 Running-In

Drain and replace the crankcase oil after the first 50 hours of operation on new gensets. Refer to the Maintenance section of this manual for the recommended procedures.

5.4.2 No-Load Operation

Periods of no load operation should be held to a minimum. If it is necessary to keep the engine running for long periods of time when no electric output is required, best engine performance will be obtained by connecting a load bank of at least 30% of nameplate rating, but not to exceed rated load. Such a load could consist of heater element or load bank.

5.4.3 Exercise Period

Gensets on continuous standby must be able to go from a cold start to being fully operational in a matter of seconds. This can impose a severe burden on engine parts.

Regular exercising keeps engine parts lubricated, prevents oxidation of electrical contacts and, in general, helps provide reliable engine starting.

Exercise the genset at least once a week for a minimum of 30 minutes with load, so the engine reaches normal operating temperatures.

5.4.4 Low Operating Temperature

Use a coolant heater if a separate source of power is available. The optional heater, available from Cummins, will help provide reliable starting under adverse weather conditions. Be sure the voltage of the separate power source is correct for the heater element rating.

5.4.5 High Operating Temperature

Refer to the genset nameplate for the maximum ambient operating temperature, if applicable.

5.5 Genset Operation

5.5.1 Sequence of Operation

The genset is run Automatically, using a Remote Start signal, or Manually, by using the genset switch panel controls. Genset indications are provided on the control panel. If a fault is sensed at Start-up, the engine is locked out and will not start.

When the PCCP is put in the Run mode, the genset performs an automatically sequenced manual start. When the PCCP is put in the Auto mode, the genset performs an automatically sequenced start when initiated by a start signal from a remote device. First, the PCCP initiates a starter cranking signal and verifies that the engine is rotating. Then it provides sufficient fuel to the engine to accelerate to start-disconnect speed.

After the initial start procedure, the control system ramps the genset to rated speed and voltage. On reaching rated speed and voltage, the PCCP checks the system bus voltage. If the genset is working in a multiple (paralleling) genset installation and no bus voltage is present, it waits for a pulse from a remote Master First Start Sensor (MFSS). On receiving that pulse, the control will signal the paralleling breaker to close.

If bus voltage is present, the PCCP checks for proper phase rotation, adjusts the genset to the bus voltage and frequency level, and then synchronises the genset to the system bus automatically. When a synchronised condition is achieved, PCCP will send a signal to close the paralleling breaker and the genset will assume its proportional share of the total load on the system bus.

5.6 Starting

Caution: *One operator should be in complete charge, or working under the direction of someone who is. Remember that, upon starting the engine, cables and switchgear will become energised, possibly for the first time. Furthermore, equipment that does not form part of the genset installation may become electrically charged. Only authorised and competent personnel should carry out this work.*

Caution: *Do not use an Emergency Stop switch to shut down an engine unless a serious fault develops. The Emergency Stop push-switch must not be used for a normal shut-down, as this will prevent a cooling down run in which the lubricating oil and engine coolant carry heat away from the engine combustion chamber and bearings in a safe manner.*

Caution: *Avoid off-load running for other than short periods. A minimum loading of 30% is recommended. This loading will help to prevent the build up of carbon deposits in the injectors, due to unburnt fuel, and reduce the risk of fuel dilution of the engine lubricating oil. The engine must be shut down as soon as possible after the appropriate functions have been checked.*

This section covers pre-start checks, starting and stopping and operating the genset. Before attempting to start the genset, the operator should read through this entire section and become familiar with the Engine and Alternator Operating Manuals. It is essential that the operator be completely familiar with the genset and the PCCP control.

Before starting the genset, make sure that exhaust and fuel fittings are tight and properly positioned, and that proper maintenance and pre-start checks have been performed.

5.6.1 Pre-Start Checks

WARNING: HIGH VOLTAGE, 601 TO 15,000 VOLTS PRESENTS SPECIAL HAZARDS OF SEVERE PERSONAL INJURY OR DEATH. EVEN AFTER GENSET SHUTDOWN AN ELECTRICAL SHOCK HAZARD MAY STILL EXIST, CAUSED BY INDUCED OR RESIDUAL VOLTAGE WITHIN THE ALTERNATOR OR CABLES. SERVICE PERSONNEL MUST BE WELL TRAINED/QUALIFIED TO WORK WITH DISTRIBUTION VOLTAGES.

WARNING: WINDINGS OF HIGH VOLTAGE, 601 TO 15,000 VOLTS, GENSETS MUST BE DRY BEFORE THE GENSET IS OPERATED. FAILURE TO ENSURE DRY WINDINGS BEFORE START-UP MAY RESULT IN CATASTROPHIC FAILURE, SEVERE PERSONNEL INJURY AND DEATH.

Before starting the genset Manually, or selecting Auto operation, be sure competent personnel have made the following checks to ensure that the unit is ready for operation:

- Genset Grounding Procedure – This must be followed prior to performing service or inspection procedures that may expose personnel to conductors normally energized with voltages greater than 600 volts. Refer to the genset Installation Manual.
- Megger and Insulation Testing – This must be performed on all high voltage (601 to 15,000 volts) gensets before initial start-up and after the genset Grounding Procedure has been completed. Insulation testing for low voltage (less than 600 volts) gensets is recommended by Cummins Power Generation Limited.
These tests are used to verify that the windings are dry before the genset is operated, and to develop a base line for future test comparisons.

Caution: *When Megger testing an alternator, failure to protect the voltage regulator, control and diodes could result in permanent damage to one or more of the electronic components.*

- Lubrication - Check the engine lubricating oil level and ensure that the level is maintained as detailed in the Engine Operation and Maintenance manual.

Note: *Gensets may be shipped dry. They must be filled with the correct type and quantity of oil before use. Be sure to check oil level before initial start.*

- Coolant - Check the engine coolant level and ensure that the level is maintained at the coolant expansion tank. Fill the cooling system to the bottom of the fill neck in the radiator fill or expansion tank. Do not check while the engine is hot.

Note: *Some radiators have two fill necks, both of which **must** be filled if the cooling system has been drained.*

Caution: *Do not attempt to remove a radiator pressure cap while the generator is running, or is stationary but hot. Always allow it to cool before removing.*

Note: *Gensets may be shipped dry. They must be filled with the correct type and quantity of coolant before use. Be sure to check coolant level(s) before initial start.*

- Cooling Air Inlet/Outlets - Ensure that the cooling air inlets/outlets are unobstructed. Remove all loose debris from surrounding area of genset. Air flow from the radiator fan can blow loose items around and into ventilation openings.
- Exhaust Outlet - Ensure that exhaust components are secured and not warped, and that the exhaust outlet is unobstructed; that no combustible materials are near the system, and gases are discharged away from building openings. Ensure that there are no leaks and that all fittings are tight.
- Fuel Supply - Ensure that the fuel tank is filled to the normal level and that the fuel system is primed and all the valves required for operation are open. Ensure that there are no leaks and that all fittings are tight.
- Batteries – Ensure that the batteries are charged, that the electrolyte is at the correct level and that all connections are correct.
- Auxiliary AC Supplies - Ensure that all auxiliary equipment is receiving power from the Load Terminal Box.
- Emergency Stop/Fire Detection Equipment - Ensure that all related equipment is fully operational.

5.7 Start / Run Procedures

WARNING: ENSURE THAT ALL PRE-START CHECKS ARE CARRIED OUT BEFORE STARTING THE GENSET. DO NOT ATTEMPT TO START THE GENERATOR UNTIL IT IS SAFE TO DO SO. WARN ALL OTHERS IN THE VICINITY THAT THE SET IS ABOUT TO START.

5.7.1 Operating Options

The genset is normally operated remotely, using a Remote Start signal. However, manual operation of each genset is also possible by using the PCCP systems on their own.

An additional option in the control system is that the PCCP can be set to run with its indicators blanked, to save battery power, or with the indicators showing all the time if the optional battery charger is used. Either way, the PCCP is still functioning in the background.

Caution: *Electrostatic discharge will damage circuit boards. To prevent this damage, always wear a grounding wrist strap when touching or handling either circuit boards or socket-mounted ICs, and also when disconnecting or connecting harness connectors.*

5.7.1.1 Automatic Operation

Automatic control of the genset is provided by positioning the three position Mode switch to the Auto position.

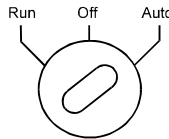

Note: *A red Non-automatic Status Indicator lamp on the PCCP will flash continuously if the Mode switch is not in the Auto position.*

5.7.1.2 Manual Operation

Manual control of the genset is provided by positioning the three position Mode switch to the Run position.

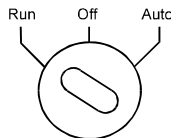

Note: *The red Non-automatic Status indicator lamp on the PCC will flash continuously if the Mode switch is not in the Auto position.*

5.7.2 Lockout

The engine will be inhibited from starting if a critical fault condition exists when an attempt is made to start the genset. An indication is initiated and a horn and beacon are activated. Additionally, a number of non-critical circumstances arise where starting is prevented such as:

- Low battery voltage
- HV Switchgear protection (option)

5.7.3 Start Procedure

5.7.3.1 Start Sequence

The following description applies to Automatic or Manual operation. In an Automatic sequence, with the Mode switch set to the Auto position, a Remote Start signal is applied to the PCCP. The Manual sequence is initiated directly by setting the Mode switch to the Run position.

The installed generators start independently of each other, controlled by their respective PCCPs. During starting, automatic checks are carried out for the integrity of various protection systems, such as the speed probe and the critical temperature sensors. The PCCP will not allow the genset to continue the starting sequence if the integrity of a sensor is considered to be in doubt by the PCCP checking system.

The starting sequence consists of three cranking intervals of approximately five seconds, each followed by a rest period of fifteen seconds. If, at any time during the sequence, the engine is sensed to have achieved firing speed (a speed calculated to be beyond the starter motor capability), the remainder of the sequence is aborted. If, at the end of the third crank period, firing speed has not been detected, the PCCP ends the start sequence and a fail to start situation is indicated as an Overcrank.

5.7.3.2 Run-up to Speed

When the engine is called to start, and firing speed is attained, the starter motor function ceases and is then locked out. The run-up sequence is closely controlled by the PCCP software to reduce smoke emission.

5.7.3.3 Generator Running

Upon attaining correct speed (frequency), and correct output voltage, the generator is deemed to be running by the PCCP. During running, all systems associated with the engine and its auxiliary systems will be monitored by the PCCP to control the generator and to detect any abnormal conditions.

If in Auto mode, the genset will continue to run off-load until signalled by the PCCP to close the genset breaker. In Manual (Run) mode, it will continue to run off-load, if the circuit breaker is open, until the Mode switch is changed to Off (which will initiate the stop sequence), or Auto (which will initiate a load transfer, if required).

Automatic synchronisation is provided for manual paralleling.

<u>Caution:</u>	<i>The engine should not be allowed to run off-load for extended periods, except as absolutely necessary during maintenance or cooling cycles.</i>
------------------------	--

5.8 Paralleling

5.8.1 Speed and Voltage Matching

Once the generator has achieved nominal voltage and frequency, the genset is ready to be paralleled with the busbar supply. Each genset is paralleled completely independently of the others.

The PCCP monitors both the incoming supply and the busbar voltage and frequency and adjusts the incoming supply to match the busbar supply over a wide span of busbar parameters. Synchronisation is achieved under full control, and at the correct phase coincidence.

In Automatic mode, the PCCP receives a breaker close signal when synchronisation has been achieved and signals the main breaker to close. In Run mode, the main breaker is closed to connect the genset to the busbars, by using the breaker Open / Close push-buttons.

5.8.2 Operation When in Parallel

When in parallel with the busbar supply, the genset voltage and frequency are dependent upon the busbar parameters, and control is changed to kW and kVAR load management.

Each genset is individually controlled by separate PCCPs.

Apart from the protection systems, there is no common coupling between gensets. This allows for any genset, or its relevant controls, to be under maintenance without affecting the others.

When the control system detects that the generator is up to speed and voltage, the load is then ramped from the mains to the generator, the engine governor control system keeping the electrical output within the correct parameters.

5.9 Shutdown Procedures

Specific procedures must be followed to shutdown the power plant, in normal use, or in an emergency situation. Additional reset procedures must also be followed in order to put the power plant back to work.

5.9.1 Normal Stop

A Normal Stop is initiated by the removal of the remote start signal, or by turning the Mode switch on the PCCP to Off.

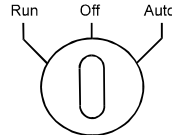

In the event of a Normal Stop, load will be ramped down before the generator circuit breaker is opened, and the engine enters a cooling run under the control of the PCCP before stopping. The cooling run allows for the safe dissipation of excess engine heat, before the engine stops and the cooling system is de-energised.

5.9.2 Emergency Stop

Press the Emergency Stop push switch located in the lower right hand corner of the PCCP's front panel

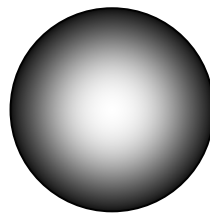

OR

Press one of the Remote Emergency Stop push switches located in the Plant Room (if separate switches are provided).

Note: *When an emergency stop is initiated all generator load is dumped immediately and the engine is stopped without a cooling run.*

Caution: *Do not use an emergency stop control for a normal stop.*

5.9.3 Emergency Stop Controls

Caution: *The Emergency Stop push-switch must not be used for a normal shut-down, as this will prevent a cooling down run in which the lubricating oil and engine coolant carry heat away from the engine combustion chamber and bearings in a safe manner.*

5.9.3.1 Emergency Stop Switches

- **PCCP Switch**

The Emergency Stop push-switch, located in the lower right hand corner of the PCCP front panel, is a mechanically latched switch that will unconditionally stop the engine when pressed. When the switch is pressed the PCCP panel will display the Shutdown condition by illuminating the red Shutdown status LED and displaying the following message on the alphanumeric display:

EMERGENCY STOP
102 - SHUTDOWN

The Emergency Stop push-switch must not be used for a normal shutdown, as this will prevent a cooling run in which the lubricating oil and engine coolant carry heat away from the engine combustion chamber and bearings in a safe manner.

- **Plant Room Switches (Optional)**

The remote Emergency Stop push-switches located in the Plant Room are mechanically latched switches that will unconditionally stop the engine when pressed. When a switch is pressed, the PCCP panel will display the Shutdown condition by illuminating the red Shutdown status LED and displaying the following message on the alphanumeric display:

EMERGENCY STOP
102 - SHUTDOWN

A remote Emergency Stop push-switch must not be used for a normal Shutdown, as this will prevent a cooling run in which the lubricating oil and engine coolant carry heat away from the engine combustion chamber and bearings in a safe manner.

5.9.4 Emergency Stop Reset

After an emergency stop, the following reset procedure must be carried out to return the genset to an operating condition:

5.9.4.1 Push switch Reset

To carry out a reset from an emergency stop condition initiated by an Emergency Stop push switch:

1. Pull the activated Emergency Stop push switch to unlatch it.
2. Move the Mode switch on the PCCP panel to Off.
3. Press the PCCP panel Reset button.
4. Select Run or Auto as required on the PCCP panel.

Caution: *Ensure that the cause of the emergency is fully investigated and remedied before an emergency stop Reset, and genset Start are attempted.*

5.10 Fault Alarms & Shutdowns

If a Fault condition is sensed by the PCCP, one of the following three events will be initiated depending on the seriousness of the Fault. Refer to Section 4, Control System, for further information.

5.10.1 Alarm

In the event of the PCCP detecting a non-critical condition, an alarm indication will be initiated and a beacon will be activated. If the genset is loaded, that loading will be maintained and the generator will continue to run at regulated speed.

5.10.2 Controlled Shutdown

In the event of a Fault condition that is serious, but not considered fatal to the engine, a controlled Shutdown will be automatically initiated by the PCCP. First an indication is initiated and a beacon is activated. Then the genset load is ramped down before the generator circuit breaker is opened, and the engine enters a cooling run under the control of the PCCP before stopping.

5.10.3 Immediate Shutdown

In the event of a Fault condition that may be fatal to the engine, an immediate Shutdown is initiated. Again an indication is initiated and a beacon is activated. This time the generator circuit breaker is opened without ramping down the load and the engine is stopped immediately, without a cooling run.

5.11 Genset Output Metering

Two types of metering are provided on the PCCP, analogue and digital. Four analogue meters provide indications of voltage, current, frequency and power for 'walkby' observations. Additional indications, which allow for better interpretation of the genset power situation, are provided on the Gen menu of the digital alphanumeric display. Details of how to access the menu and its sub-menus are given in Section 4.2 Menu Display and Switches.

5.11.1 Load Voltage

The analogue, dual scale, AC voltmeter, on the PCCP, displays the outgoing load voltage of the generator. By using the Phase Select switch, the operator can choose which phase is displayed. Indication of the phase selected is given by illumination of the appropriate phase selector indicator light. The upper or lower scale of the voltmeter is selected automatically and identified by illumination of the upper or lower scale indicator light.

Additional indications can be shown on the alphanumeric display. The indications are genset output voltage (3-phase, line-to-line or line-to-neutral) and parallel bus voltage (3-phase, line-to-line).

The generator output voltage is given on the Generator Set Rating Plate

WARNING: UNDER NO CIRCUMSTANCES MUST THE SET BE OPERATED AT A GREATER VOLTAGE THAN THE RATED VOLTAGE STAMPED ON THE GENERATOR SET RATING PLATE. SERIOUS DAMAGE OR INJURY MAY RESULT IF THIS CONDITION IS ALLOWED TO OCCUR.

5.11.2 Load Current

An analogue AC ammeter is provided to indicate the outgoing load current in each phase of the generator output. By using the Phase Select switch, the operator can choose which phase is displayed. Indication of the phase selected is given by illumination of the appropriate phase selector indicator light.

Additional indications of genset output current can be accessed by selecting the Gen menu on the alphanumeric display.

The generator output current is given on the Generator Set Rating Plate.

WARNING: UNDER NO CIRCUMSTANCES SHOULD THE LOAD CURRENT BE ALLOWED TO RISE ABOVE THE RATED OUTPUT CURRENT, ALLOWING FOR ANY OVERLOAD RATING GIVEN. IF HIGH CURRENT READINGS ARE ENCOUNTERED, THE POWER FACTOR OF THE LOAD SHOULD BE CHECKED.

5.11.3 Load Power

The analogue kilowatt meter displays 3-phase AC power output as a percentage of rated load. This is a true indication of total kW load, regardless of the power factor.

Additional indications of power can be shown on the alphanumeric display. The indications are AC kilowatt load and AC kilowatt hours. Power Factor (PF) is also shown, with a display of 0 - 1, leading or lagging. An asterisk is included for leading power factors.

5.11.4 Genset Frequency

The analogue frequency meter displays the output frequency of the genset in Hz.

Additional indications are provided on the alphanumeric display. The indications are genset output frequency and parallel bus frequency.

Frequency is directly related to engine speed and, for a nominal engine speed of 1500 RPM (or 1800 RPM), the relationship between engine speed and frequency is given by the following formula:

$$\text{Hz} = \text{RPM} / 30 \text{ (for a 4-pole machine)}$$

Where Hz represents the output frequency of the alternator and RPM is the engine speed

The generator output frequency is given on the Plant Rating Plate on the generator.

Caution: *Under no circumstances must the Set be operated outside the rated frequency range stamped on the Generator Set Rating Plate. Serious damage or injury may result if this condition is allowed to occur.*

5.11.5 Bus Synchronisation

A synchroscope can be shown on the alphanumeric display, and this provides a visual display of the genset synchronising with the system bus under full control of the PCCP. Bus frequency is shown, along with degrees difference (plus or minus). An asterisk is included on the display when genset frequency is within a sync-check window, signalling that the operator can effect closure of the paralleling breaker.

Note: *The PCCP inhibits closure of the paralleling breaker outside the sync-check window. Therefore the breaker close control can be operated even before synchronisation, although the breaker will not close until a signal is sent from the PCCP to allow it.*

5.11.6 Duty Cycles

To complete the observations of genset power status provided by the PCCP, the Gen menu of the alphanumeric display can be set to show percentages of generator exciter duty and governor duty.

5.12 Engine Metering

Engine and auxiliary system parameters are constantly monitored by the PCCP. No action is required by the operator, except for maintenance as described in Section 6. Indications for the following critical parameters can be displayed on the alphanumeric display, by using the Engine menu as detailed in Section 4.2.3 Engine Menu:

- Oil temperature
- Coolant temperature
- Exhaust gas temperature (option)
- Oil pressure
- Engine speed
- Battery voltage
- Engine operating hours
- Number of starts

5.13 Options

5.13.1 Heaters

Caution: Heater(s) must not be energised if coolant system has been drained.

5.13.1.1 Coolant Heater

The coolant heater is controlled by its associated thermostat to maintain a reasonable engine temperature. The heater is locked out by the PCCP at engine start.

WARNING: ALWAYS ISOLATE THE SUPPLY TO THE ENGINE HEATER / THERMOSTAT BEFORE CARRYING OUT ANY MAINTENANCE ON THE ENGINE. ALWAYS ISOLATE THE GENSET PRIOR TO ANY MAINTENANCE.

Caution: The coolant heater is in no way intended to protect the engine and cooling system from freezing in sub zero conditions. If there is any danger of freezing then a suitable antifreeze agent must be added to the cooling system.

5.13.1.2 Alternator Heater

The alternator heater is controlled by its associated thermostat. The heater is locked out by the PCCP at engine start.

WARNING: ALWAYS ISOLATE THE SUPPLY TO THE ALTERNATOR AND THE THERMOSTAT BEFORE CARRYING OUT MAINTENANCE ON THE ALTERNATOR.

5.13.1.3 Control Panel Heater

The control panel heater is controlled by its associated thermostat. The heater is locked out by the PCCP at engine start.

WARNING: ALWAYS ISOLATE THE CONTROL PANEL HEATER FROM THE AC SUPPLY BEFORE WORKING ON THE CONTROL PANEL OR HEATER.

5.13.2 Digital Master Control

The Digital Master Control (DMC) is a stand-alone system that controls multiple genset installations and utility supply switching. The control equipment includes a touchscreen, digital meters and annunciators, all mounted in a single enclosure.

Refer to separate manual for DMC configurations and availability.

SECTION 6 – MAINTENANCE

6 Maintenance

Maintenance work, particularly in confined areas, should be carried out by two engineers working together.

Read, understand and comply with all Caution and Warning notes in this section, those contained within Section 1 – Preliminary and Safety, and those contained within the Health and Safety Manual (3553).

Ensure that adequate lighting and staging (where required) are installed.

Caution: Only authorised and qualified maintenance engineers who are familiar with the equipment and its operation should carry out maintenance.

WARNING: DEPENDENT UPON THE CONTROL SYSTEM FITTED, THIS UNIT MAY OPERATE AUTOMATICALLY AND COULD START WITHOUT WARNING.

Caution: Before carrying out any maintenance work, become familiar with the Generator Plant Safety Code given in Section 1 of this manual, together with the Health and Safety Manual (3553).

Caution: Remove AC power to the cooling system heaters before disconnecting battery leads. Heaters will run continuously without DC power and can overheat and become damaged.

Caution: Always disconnect a battery charger from its AC source before disconnecting the battery leads. Failure to do so can result in voltage spikes high enough to damage the DC control circuits of the genset.

WARNING: ACCIDENTAL STARTING OF THE GENSET WHILE WORKING ON IT CAN CAUSE SEVERE PERSONAL INJURY OR DEATH. PREVENT ACCIDENTAL STARTING BY DISCONNECTING THE STARTING BATTERY LEADS (NEGATIVE [-] FIRST).

ENSURE BATTERY AREA HAS BEEN WELL VENTILATED BEFORE SERVICING THE BATTERY. ARCING CAN IGNITE EXPLOSIVE HYDROGEN GAS, GIVEN OFF BY BATTERIES, CAUSING SEVERE PERSONAL INJURY. ARCING CAN OCCUR WHEN LEADS ARE REMOVED OR REPLACED, OR WHEN THE NEGATIVE (-) BATTERY LEAD IS CONNECTED AND A TOOL USED TO CONNECT OR DISCONNECT THE POSITIVE(+) BATTERY LEAD TOUCHES THE FRAME OR OTHER GROUNDED METAL PART OF THE GENSET.

INSULATED TOOLS **MUST** BE USED WHEN WORKING IN THE VICINITY OF THE BATTERIES.
ALWAYS REMOVE THE NEGATIVE (-) LEAD FIRST AND RECONNECT LAST.

ENSURE HYDROGEN FROM THE BATTERY, ENGINE FUEL AND OTHER EXPLOSIVE FUMES ARE FULLY DISSIPATED. THIS IS ESPECIALLY IMPORTANT IF THE BATTERY HAS BEEN CONNECTED TO A BATTERY CHARGER.

WARNING: BEFORE CARRYING OUT ANY MAINTENANCE WORK LOCK OFF FOR SAFE WORKING (SEE SECTION 6-2):

1. SELECT THE MODE SWITCH ON THE GENSET CONTROL PANEL TO OFF.
2. REMOVE AND ACCOUNT FOR THE KEY(S) IF THE MODE SWITCH IS OF THE KEY SWITCH TYPE.
3. ISOLATE ALL SUPPLIES TO THE GENERATOR.
4. ISOLATE THE BATTERY CHARGER.
5. DISCONNECT THE BATTERY.
6. REMOVE THE STARTER CONTROL WIRES.
7. A SUITABLE WARNING PLATE STATING 'MAINTENANCE IN PROGRESS' SHOULD BE DISPLAYED PROMINENTLY.

WARNING: SOME PANEL INTERNAL COMPONENTS MAY HAVE LIVE EXPOSED TERMINATIONS EVEN IF THE GENSET IS NOT RUNNING. ISOLATE ALL EXTERNAL ELECTRICAL SUPPLIES PRIOR TO ACCESS OF THE CONTROL PANEL.

6.1 General

Preventative maintenance begins with day-to-day awareness of the condition of the engine and its system. Before starting the genset, check the fuel, oil and coolant levels. Look for:

- Leaks
- Loose or damaged parts
- Worn or damaged belts
- Any change in genset appearance

When the genset is running, listen for any unusual engine or alternator noise which may indicate that a service, or attention, is required.

Establish and adhere to a definite schedule for maintenance and service based on the application and severity of the environment. The following table covers the recommended service intervals for a genset on Standby service. If the genset will be subjected to extreme operating conditions, the service intervals should be reduced accordingly. Some of the factors that can affect the maintenance schedule are:

- Use for continuous duty (prime power)
- Extremes in ambient temperature
- Exposure to elements
- Exposure to salt water
- Exposure to dust or sand or other airborne contaminants.

Consult with an authorised distributor if the genset will be subjected to any extreme operating conditions and determine a suitable schedule of maintenance. Use the running time meter to keep an accurate log of all service performed for warranty support. Perform all services at the time period indicated or after the number of operating hours indicated whichever comes first. Use Tables 6-1 and 6-2 to determine the maintenance required and then refer to the sections that follow for the correct service procedures.

Refer also to the Engine Operation and Maintenance Manual, and the Alternator Operation and Maintenance Manual.

Table 6-1 Suggested Maintenance Schedule

MAINTENANCE ITEMS		Daily or after 8 Hours	Weekly or after 50 Hours	Monthly or after 100 Hours	6 Months or after 250 Hours	Yearly or after 500 Hours
Perform any maintenance tasks specified in the Engine Operation and Maintenance Manual.		As directed¹				
Check:	Engine oil level	<input type="checkbox"/> ¹				
	Coolant level of radiator(s) (water jacket & LTA)	<input type="checkbox"/> ¹				
	Fuel tank level	<input type="checkbox"/>				
	Coolant heater(s)	<input type="checkbox"/>				
	Battery electrolyte level		<input type="checkbox"/>			
	Battery charging system		<input type="checkbox"/>			
	All exhaust components, and hardware (fittings, clamps, fasteners, etc.)		<input type="checkbox"/>			
	Drive belt, condition and tension			<input type="checkbox"/> ^{3, 1}		
	Generator air outlet			<input type="checkbox"/> ¹		
	Radiator hoses for wear and cracks				<input type="checkbox"/>	
	Sealed fan bearing, or water pump, for wear or seepage			<input type="checkbox"/> ¹		
	Air cleaner (replace as necessary)		<input type="checkbox"/> ¹			
	Anti-freeze and DCA concentration			<input type="checkbox"/> ¹		
	Governor adjustment				<input type="checkbox"/>	
	Grease:	Fan bearing				<input type="checkbox"/> ^{5, 1}
Drain:	Water from fuel pre-filter	<input type="checkbox"/> ¹				
	Exhaust condensate trap			<input type="checkbox"/>		
	Water and sediment from Fuel Tank		<input type="checkbox"/> ⁶			
Change:	Water jacket coolant filters				<input type="checkbox"/> ¹	
	Fuel filters					<input type="checkbox"/> ¹
	Engine oil and filter				<input type="checkbox"/> ¹	
	Air cleaner element				<input type="checkbox"/> ¹	
Clean:	Crankcase breather				<input type="checkbox"/> ¹	
	Water jacket & LTA cooling systems					<input type="checkbox"/> ¹
	Charge air cooler (if fitted)					800 hours
	Air filter or check oil bath			<input type="checkbox"/>		
	Radiator matrix			<input type="checkbox"/>		
	Engine			<input type="checkbox"/>		
Test:	Generator insulation resistance					<input type="checkbox"/> ⁴

- ¹–Refer to the Engine Operation and Maintenance Manuals for maintenance intervals and/or procedures.
- ²–Check for oil, fuel, cooling and exhaust system leaks. Check exhaust system audibly and visually with genset running and repair any leaks immediately.
- ³–Visually check belt for evidence of wear or slippage. Replace if hard or brittle.
- ⁴–This procedure should be followed periodically throughout the life of the genset, or if the generator has sat idle for a period of time with no generator heaters used. Contact your authorised service centre.
- ⁵–Refer also to Fan Bearing Re-lubrication Manual 3554.
- ⁶–Drain one cup, or more, of fuel to remove water and sediment.

Table 6-2 Additional Maintenance Schedule

ITEM	TASK	Weekly / 10 hours	Monthly / 100 hours	Yearly / 200 hours
Set Electrics	Clean battery terminals and re-grease			<input type="checkbox"/>
	Check fuel solenoid and linkage		<input type="checkbox"/>	
	Check all electrical connections	<input type="checkbox"/>		
	Clean all apertures (with vacuum cleaner)		<input type="checkbox"/>	
Alternator	Perform any maintenance tasks specified in the Alternator Installation, Service and Maintenance Manual	As directed		
	Grease bearings if required		<input type="checkbox"/> ²	
	Check all ventilation points	<input type="checkbox"/>		
	Clean the alternator		<input type="checkbox"/>	
Control Panel	Check circuit breaker contacts and check power cable connections for security	<input type="checkbox"/>		
	Carry out a Lamp Test	<input type="checkbox"/>		
	Check all fuses and tripping devices			<input type="checkbox"/>
	Clean the control panel		<input type="checkbox"/>	
	Check security of all fixings as required			<input type="checkbox"/>
General	Check plant room for cleanliness			<input type="checkbox"/>
	Have set / panel inspected by manufacturer			<input type="checkbox"/>
	Check air inlets / outlets for freedom from obstruction		<input type="checkbox"/>	
	Drain water and sediment from fuel tank		<input type="checkbox"/>	
Test Run	Run the set on-load — at least 30% load		<input type="checkbox"/> ¹	
	Check anti-vibration mounts		<input type="checkbox"/>	
	Check all systems functioning		<input type="checkbox"/>	
	Check operation of Emergency Stop		<input type="checkbox"/>	

¹—This procedure should be followed periodically throughout the life of the genset, or if the generator has sat idle for a period of time with no generator heaters used. Contact your authorised service centre.

²— Lubricate the bearing according to the alternator manufacturer's instructions. These instructions are contained within the Alternator Manufacturer's Operation & Maintenance Manual provided with the genset.

6.2 Locking the Genset Out of Service

6.2.1 Introduction

Before any work is carried out for maintenance, etc, the plant must be immobilised. Even if the plant is put out of service using the Mode switch Off position on the PCCP panel, the plant cannot be considered safe to work on until the engine is properly immobilised as detailed in the following procedures.

WARNING: BEFORE CARRYING OUT ANY MAINTENANCE, ISOLATE ALL SUPPLIES TO THE GENERATOR AND ANY CONTROL PANELS. RENDER THE GENERATOR INOPERATIVE BY DISCONNECTING THE PLANT BATTERY.

Caution: Remove AC power to the cooling system heaters before disconnecting battery leads. Heaters will run continuously without DC power and can overheat and damage heater.

Caution: If the engine has been running recently, explosive gases (given off during battery charging) may be present in the vicinity of the batteries. Ensure the area is well ventilated before disconnecting batteries.

6.2.2 Immobilising the Plant for Safe Working

Note: Shutdown the engine first, as described under Normal Stop.

To immobilise the engine:

1. Turn the Mode switch on the PCCP panel to the Off position.

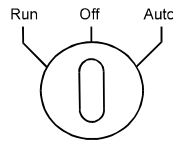

2. Remove the key from the Mode switch and account for all other keys for safekeeping, (if applicable).
3. As an additional precaution, thoroughly ventilate the plant room before disconnecting and leads.
4. Isolate and lock off the heater control box, where fitted.
5. Isolate and lock off the supply to the battery charger, where fitted.
6. Isolate the fuel supply to the engine.
7. Disconnect the starting batteries and control system batteries (if separate). Disconnect the negative (-) lead first.
8. Fit warning notices at each of the above points to indicate Maintenance in Progress - Plant Immobilised for Safe Working.

6.3 General Inspection

During operation, be alert for mechanical problems that could create unsafe or hazardous conditions. The following sections cover several areas that should be frequently inspected for continued safe operation.

6.3.1 Exhaust System

With the genset operating, inspect the entire exhaust system visually and audibly including the exhaust manifold, muffler, and exhaust pipe. Check for leaks at all connections, welds, gaskets and joints, and ensure that exhaust pipes are not heating surrounding areas excessively. If any leaks are detected, shut down the genset and have the leaks corrected immediately.

WARNING: INHALATION OF EXHAUST GASES CAN RESULT IN SERIOUS PERSONAL INJURY OR DEATH. BE SURE DEADLY EXHAUST GAS IS PIPED OUTSIDE AND AWAY FROM WINDOWS, DOORS OR OTHER INLETS TO BUILDINGS. DO NOT ALLOW TO ACCUMULATE IN HABITABLE AREAS.

6.3.2 Fuel System

With the genset operating, inspect the fuel supply lines, return lines, filters, and fittings for leaks. Check any flexible sections for cuts, cracks and abrasions and ensure they are not rubbing against anything that could cause breakage. If any leaks are detected, have them corrected immediately.

WARNING: IGNITION OF FUEL CAN CAUSE SERIOUS PERSONAL INJURY OR DEATH BY FIRE OR EXPLOSION. DO NOT PERMIT ANY FLAME, CIGARETTE, OR OTHER IGNITER NEAR THE FUEL SYSTEM, OR IN AREAS SHARING VENTILATION.

WARNING: ENGINE FUEL ACTUATORS CAN OPERATE AT VOLTAGES UP TO 140 VOLTS DC.

6.3.3 AC Electric System

Check the following while the genset is operating:

- **Frequency:** The genset frequency should be stable and the reading should be the same as the genset nameplate rating. (50Hz/1500RPM or 60Hz/1800RPM).
- **AC Voltage:** At no load, the line-to-line voltage(s) should be the same as the genset nameplate rating.
- **AC Ammeter:** At no load, the current readings should be zero. With a load applied, each line current should be similar.
- **Panel Lamps:** Press and hold down the Panel Lamp/Lamp Test button on the control panel. All indicator lamps should light. Verify that all lamps are on and then release the button. Contact an authorised service centre if any lamps are burnt out.

6.3.4 DC Electrical System

Check the terminals on the batteries for clean and tight connections. Loose or corroded connections create resistance, which can hinder starting. Clean and reconnect the battery cables if loose. Always disconnect both ends of the negative battery cable. Reconnect one end of the cable to the negative battery terminal and the other end to ground. This will ensure that any arcing will be away from the battery and least likely to ignite explosive battery gases.

WARNING: IGNITION OF EXPLOSIVE BATTERY GASES CAN CAUSE SEVERE PERSONAL INJURY. DO NOT SMOKE WHILE SERVICING BATTERIES.

Refer to Supplementary Publication 3330 for cleaning and safety precautions of the battery.

6.3.5 Engine

Monitor fluid levels, oil pressure, and coolant temperatures frequently. Refer to the Engine Operation and Maintenance Manual for recommended operating pressures and temperatures.

Most engine problems give an early warning. Look and listen for changes in engine performance, sound, or appearance that can indicate service or repair is needed. Some engine changes to look for are as follows:

- Misfire
- Vibration
- Unusual noises
- Sudden changes in engine operating temperatures or pressures
- Excessive exhaust smoke
- Loss of power
- An increase in oil consumption
- An increase in fuel consumption
- Fuel, oil, or coolant leaks.

6.3.6 Mechanical

WARNING: ACCIDENTAL STARTING OF THE GENSET CAN CAUSE SEVERE PERSONAL INJURY OR DEATH. TURN THE CONTROL SWITCH TO THE STOP POSITION AND DISCONNECT THE NEGATIVE (-) BATTERY CABLE BEFORE INSPECTING THE GENSET.

With the genset stopped, check for loose belts and fittings, leaking gaskets and hoses, or any signs of mechanical damage. If any problems are found, have them corrected immediately.

With the set running, listen for any unusual noises that may indicate mechanical problems and check the oil pressure frequently. Investigate anything that indicates possible mechanical problems.

6.4 Lubrication System

Note: *Gensets may be shipped dry. They must be filled with the correct type and quantity of oil before use. Be sure to check the oil level before initial start.*

6.4.1 Oil API Classification

Refer to the Engine Operation and Maintenance Manual for lubricating oil classification.

6.4.2 Oil Viscosity

Refer to the Engine Operation and Maintenance Manual for lubricating oil recommendations/specifications.

6.4.3 Engine Oil Level

Check the engine oil level during engine shutdown periods at the intervals specified in the Maintenance Table 6-1. The dipstick is stamped with high and low marks to indicate the level of oil in the crankcase. For accurate readings, shut off the engine and wait approximately fifteen minutes before checking the oil level. This allows oil in the upper portion of the engine to drain back into the crankcase.

WARNING: **CRANKCASE PRESSURE CAN BLOW OUT HOT OIL AND CAUSE SEVERE BURNS. DO NOT CHECK OIL WHILE THE GENSET IS OPERATING.**

Keep the oil level as near as possible to the high mark on the dipstick but never above it. Remove the oil fill cap and add oil of the same API viscosity and brand when necessary. Replace the oil fill cap after adding oil. Refer to the Engine Operation and Maintenance manual for the position of the oil dipstick and oil filler.

Caution: *Do not operate the engine with the oil level below the low mark or above the high mark. Overfilling can cause foaming or aeration of the oil while operation below the low mark may cause loss of oil pressure.*

6.4.4 Oil and Filter Change

Change the oil and filter at the intervals specified in the Maintenance Table 6-1. Refer to, Engine Operation and Maintenance Manual for information regarding oil capacity. Use oil that meets Cummins recommendations/specifications, or its equivalent.

Refer to the Engine Operation and Maintenance Manual for maintenance intervals and procedures.

6.4.5 Starting Procedure After Extended Shutdown or Oil Change

After each oil change or if the genset has not been exercised within the past seven days, the lubricating system must be primed to be sure that the engine receives the correct oil flow through the lubricating system to minimise engine wear. To prime the lubricating system:

- Disconnect the electrical wire from the fuel injection pump solenoid valve.
- Rotate the crankshaft, using the starter motor, until oil pressure appears on the gauge or the warning lamp is extinguished.
- Reconnect the electrical wire to the fuel injection pump solenoid valve.
- Start the engine using the Manual Run button on the switch panel to start the engine (refer to Start/Run procedures Section 5.7). Using the Manual Run button, the engine will start in idle mode, but will go to rated speed after warm-up. Run the engine for five to ten minutes, off load, but no more than ten minutes.

Note: *If the engine is allowed to run out of fuel, air is pulled into the fuel lines. Refer to the Engine Operation and Maintenance Manual for instructions to vent the fuel system.*

6.5 Coolant System

Note: *Gensets may be shipped dry. They must be filled with the correct type and quantity of coolant before use. Be sure to check the coolant level before initial start.*

Caution: *The heaters must not be operated while the cooling system is empty, or when the engine is running, or damage to the heater will occur. Isolate AC power to the heaters before disconnecting battery cables. Heaters will run continuously without DC power and can overheat and become damaged.*

Caution: *Do not add cold coolant to a hot engine. Engine castings can be damaged. Allow the engine to cool to below 50°C (122°F) before adding coolant.*

6.5.1 Anti-freeze Concentration

The standard coolant mixture for a typical genset is 25% Ethylene Glycol and 75% water for protection down to -10°C (14°F). Warranty claims for damage caused by freezing to any component will be rejected if the incorrect mix of anti-freeze has been used. Consult your authorised distributor for other options, and for specific genset information.

6.5.2 Coolant Level

WARNING: **CONTACT WITH HOT COOLANT CAN RESULT IN SERIOUS BURNS. ALLOW COOLING SYSTEM TO COOL BEFORE RELEASING PRESSURE AND REMOVING WATER JACKET RADIATOR CAP OR LTA EXPANSION TANK CAP.**

Caution: *Loss of coolant can allow engine to overheat without protection of shutdown device, and cause severe damage to the engine. Maintain coolant level for proper operation of high engine temperature shutdown system.*

Check the coolant level during shutdown periods at the intervals specified in the Maintenance Table 6-1.

The coolant level should be approximately in the middle of the sight glass, with the coolant temperature at 50°C (122°F) or lower. Refer to the Engine Operation and Maintenance Manual for further, general information.

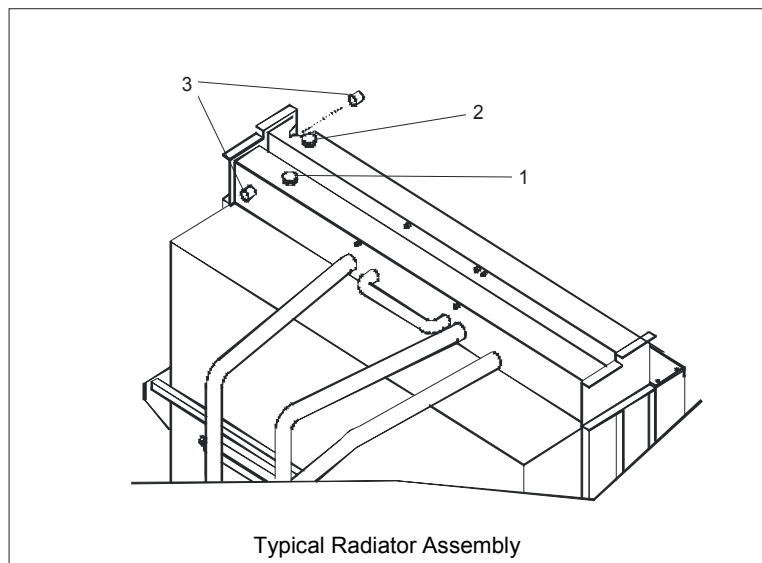

1. LTA Cooling System Fill Cap
2. Water Jacket Cooling System Fill Cap
3. Coolant Sight Glass

6.5.3 Cooling System Maintenance

Caution: Failure to use the correct type of coolant, maintain the correct level and bleed the system of air can result in severe engine damage.

Refer to the Engine Operation and Maintenance Manual for all cooling system maintenance, such as coolant requirements, filling of the engine water jacket and LTA cooling systems, coolant filter replacement, and flushing and cleaning. Refer to Figure 6-1 for the coolant drain locations of the aftercooler and water jacket systems of a typical genset. Refer to drawings supplied for your specific installation.

If engine coolant heater(s) is installed in the water jacket cooling system, disconnect heater(s) from power source before performing cooling system maintenance.

Caution: The heater element will burn out if the engine coolant is removed with the heater connected to power source.

Caution: The heater element will burn out if the power is connected before it is filled with coolant, or if straight antifreeze solution is used for coolant. Before connecting the power, fill the engine with coolant and run it for a minimum of ten minutes to circulate coolant through the heater.

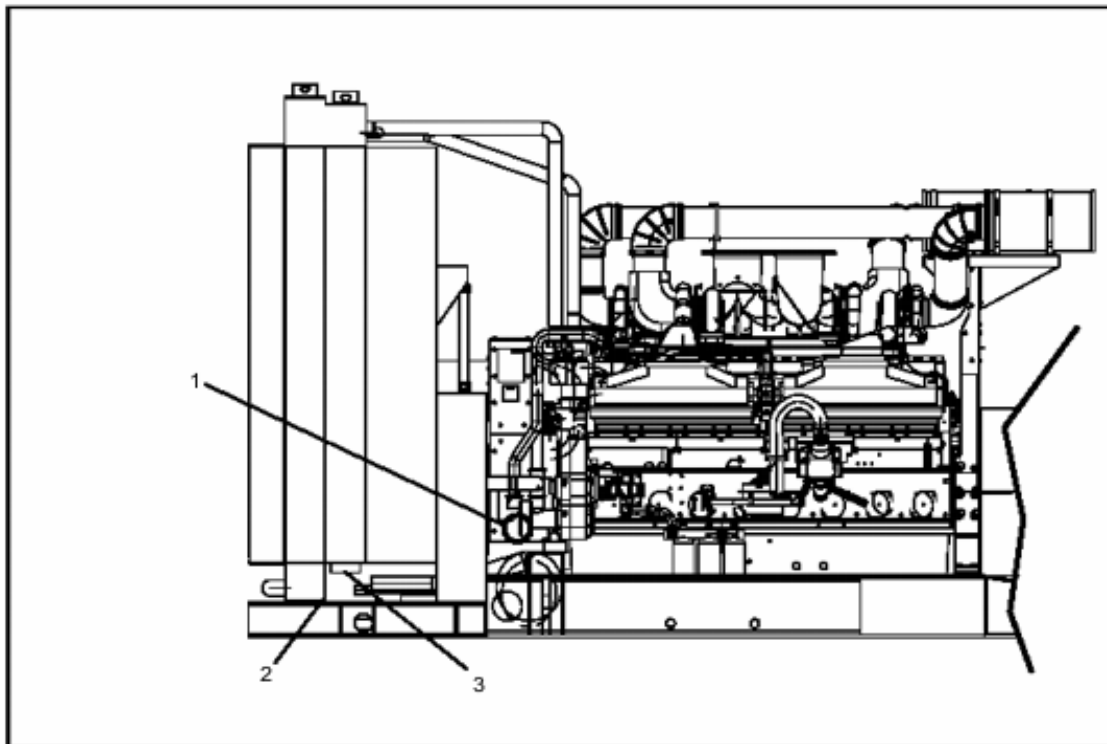

Figure 6-1 Typical After Cooler/Water Jacket Coolant Drain Locations

1. After Cooler Coolant Drain
2. Water jacket Coolant Drain (Both Sides)
3. After Cooler Coolant Drain (Both Sides)

6.5.4 Radiator

Inspect the exterior of the radiator for obstructions. During the service life of a radiator a build up of foreign matter can obstruct the flow of air through the radiator cores, reducing the cooling capability. To ensure the continued efficiency of the radiator, the core will require cleaning.

Refer to the Radiator Information Manual 3554 for further details on cleaning the radiator and greasing the bearings.

LITHIUM AND POLYUREA GREASES ARE NOT COMPATIBLE AND MUST NOT BE MIXED.

6.5.5 Fan Bearings Re-lubrication

Re-lubricate the fan bearings at the interval specified in the Maintenance Table 6-1. A grease fitting is provided for the bearings to allow the use of a grease gun to re-lubricate the bearings with the following quantities:

Fan side bearing	6 Grams
Pulley side bearing	8 grams

The recommended lubricant is a lithium based grease, such as, Mobilux EP 2, Mobilith AW 2, or Shell Alvania R3.

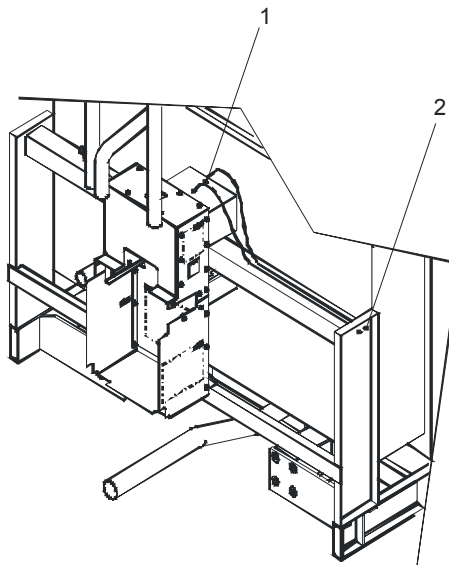

Figure 6-2 Fan Bearing Grease Fittings

1.	Bearings
2.	Grease Fittings

6.5.6 Coolant Heater

WARNING: CONTACT WITH COOLING SYSTEM OR ENGINE CAN RESULT IN SERIOUS BURNS. DO NOT TOUCH COOLING SYSTEM OR ENGINE DURING GENSET MAINTENANCE UNTIL THEY ARE COOL.

Check the operation of the coolant heater by verifying that hot coolant is being discharged from the outlet hose (see Figure 6–3). Do not touch the outlet hose – if heater is operational, radiant heat should be felt with hand held close to outlet hose.

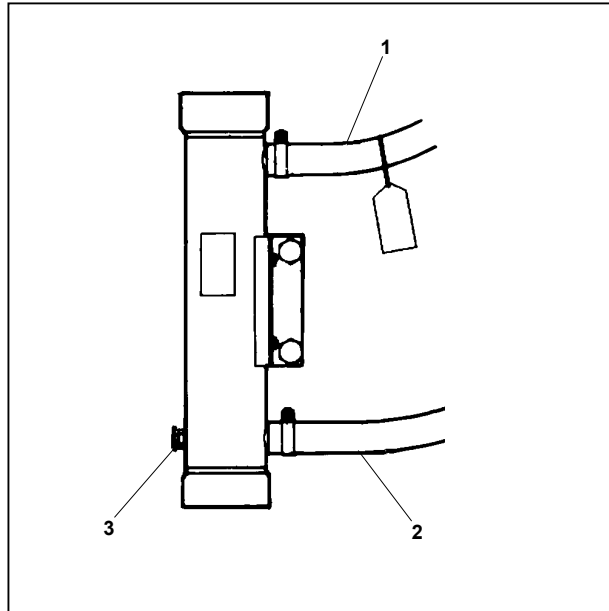

Figure 6-3 Typical Coolant Heater

1. Outlet
2. Inlet
3. Drain

6.6 Heat Exchanger Cooling System (Optional)

Various optional heat exchangers are available. Please refer to your authorised distributor for further information.

6.7 Fuel System

Refer to the Engine Operation and Maintenance Manual for fuel recommendations and fuel system maintenance, such as draining of the fuel–water separators and fuel filter replacement interval and procedure.

6.7.1 Fuel Handling Precautions

<p><u>WARNING:</u> IGNITION OF FUEL CAN CAUSE SERIOUS PERSONAL INJURY OR DEATH BY FIRE OR EXPLOSION. DO NOT PERMIT ANY FLAME, CIGARETTE, OR OTHER IGNITER NEAR THE FUEL SYSTEM.</p>
--

To avoid condensation problems, keep fuel supply tanks as full as possible by filling up each time the engine is used. In cold weather, warm fuel returning from the injectors heats the fuel in the supply tank. If the fuel level is low, the upper portion of the tank tends to form condensation. In warm weather, both the fuel and the tank will be warm during the daytime. At night, cool air tends to lower the temperature of the tank more rapidly than the temperature of the fuel. If the fuel level is low, the upper portion of the tank will cool more rapidly and tend to form condensation.

Condensation (water) can cause clogging of fuel filters when the sulphur in the fuel forms acid, which can corrode and damage engine parts.

6.8 Air Cleaner

Refer to the Engine Operation and Maintenance Manual for air-cleaner filter element replacement, interval and procedure.

6.9 AC Generator Bearing Re-lubrication

Caution: *The bearing must be filled with the same type of grease used when the alternator was manufactured. This grease, Kluber type ASONIC GHY72, was chosen to provide optimum lubrication and MUST NOT be mixed with any other type of grease.
To locate the nearest Kluber distributor please refer to the Kluber Web site at: www.kluber.com*

6.9.1 Lubrication

It is important that the correct type and quantity of grease is used for periodic re-lubrication with a grease gun during planned maintenance. Refer to the label located adjacent to the end bearing of the alternator (if provided) or Table 6-3, which specifies the grease fill quantity. (Refer also to Maintenance Tables 6-1 and 6-2).

Table 6-3 Maintenance Chart for Re-Grease

Frame	Bearing Part Number**	Grease Qty		Re-Lubrication Period (hours)
		Grams	Ounces	
7*	Non-Drive End	18.75	0.66	1000
7*	Drive End	22.25	.79	1000
8*	6324 C3	37.75	1.33	1000
8*	6232 C3	30.25	1.07	1000
8*	6236 C3	43.25	1.52	1000

* Frame 7 outside casing is round, Frame 8 outside casing is octagonal (flat sided)
** Refer to label located at bearing end of alternator for bearing part no.

To determine how much grease is supplied with each pump (stroke) of the device, weigh the quantity required (e.g., 37.75 grams or 1.33 ounces), against the number of pump strokes taken to inject that amount onto a small weighing scale. Also, note in practice:

- If the pump hits an airlock, (i.e., no pressure when pumping) these strokes cannot be counted.
- For greater accuracy, the grease fitting can be unscrewed, and a flexible grease-pipe screwed directly to the fitting adapter. This will make sure that no grease is expelled outside of the fitting.
- If too much grease is applied, any excess will be exhausted out of the bearing cartridge via the grease escape. (Any exhausted grease should be cleaned out of the PMG cover.)
- Always extend the grease gun pump arm out to its full extent with each pump, failure to do this could mean little or no grease is going into the bearing.

Note: *It is very important that these lubrication instructions are strictly adhered to*

6.9.2 Re-Lubrication Procedure

Re-lubricate the bearing(s) at the intervals specified in the Maintenance Tables 6-1 and 6-2 and 6-3. These intervals may differ from those specified on the label located adjacent to the end bearing of the alternator. Use the information provided in this manual for these values.

Lubricate the bearing according to the instructions contained within the Alternator Manufacturer's Operation & Maintenance Manual supplied with the genset. A grease fitting is provided to allow the use of a grease gun to re-lubricate the bearing.

1. Make sure grease gun nozzle and re-lubricating fitting are free from contaminants or abrasive material.
2. With the genset running, apply the specified re-lubrication grease fill quantity through the grease fitting.
3. Run the genset for at a minimum of ten minutes to allow excess grease to exhaust.
4. Check inside the PMG cover for expelled grease. Clean out as necessary.

6.10 Test Runs

6.10.1 Pre-start Checks

Before starting the plant Manually, or selecting Auto operation, be sure competent personnel have completed the pre-start checks (see Section 5.6.1), and taken all health and safety actions to ensure that the unit is ready for operation.

6.10.2 Off-load Initial Run

WARNING: ENSURE THAT ALL PRE-START CHECKS ARE CARRIED OUT BEFORE STARTING THE GENSET. DO NOT ATTEMPT TO START THE GENERATOR UNTIL IT IS SAFE TO DO SO. WARN ALL OTHERS IN THE VICINITY THAT THE SET IS ABOUT TO START.

Caution: *One operator should be in complete charge, or working under the direction of someone who is. Remember that, upon starting the engine, cables and switchgear will become energised, possibly for the first time. Furthermore, equipment that does not form part of the generator installation may become electrically charged. Only authorised and competent personnel should carry out this work.*

Caution: *Do not use an Emergency Stop switch to shut down an engine unless a serious fault develops. The Emergency Stop push-switch must not be used for a normal shut-down, as this will prevent a cooling down run in which the lubricating oil and engine coolant carry heat away from the engine combustion chamber and bearings in a safe manner.*

Caution: *Avoid off-load running for other than short periods. A minimum loading of 30% is recommended. This loading will help to prevent the build up of carbon deposits in the injectors, due to unburnt fuel, and reduce the risk of fuel dilution of the engine lubricating oil. The engine must be shutdown as soon as possible after the appropriate functions have been checked.*

The PCCP will automatically make up to three start attempts, and lock the engine out of service if the third attempt fails. If the PCCP senses an operating fault, either a Warning will be indicated on the PCCP or the engine will be shut down automatically. Automatic shutdowns require no operator action other than to observe the detail.

Note: *The Non-Automatic LED on the PCCP will be illuminated whenever the Mode switch is not set to Auto. Also, if the PCCP is set to operate with the Standby (Sleep) Mode active, the PCCP indications may de-activate and need to be reactivated (press the Self-Test membrane switch to reactivate).*

1. As a precautionary measure, for the initial runs only, place suitable fire extinguishers at strategic locations around the genset. Also ensure that all test personnel are fully aware of the positions of all emergency shutdown switches and fire break glass units (if fitted).
2. If the ambient temperature is low, it is preferable to have had the engine / alternator / panel heaters on for some time beforehand to improve starting and to eliminate any condensation.
3. On the PCCP, set the Mode switch to Run and check that the engine starts and runs automatically. The PCCP may make up to three start attempts before it terminates the automatic start-up function. If all three start attempts fail, the fault must be investigated before the system is reset and another start-up is initiated.

4. During start-up and the initial run, observe the PCCP and check for unusual indications that may highlight a problem; observe the associated power systems for signs of flashovers, burning, etc. Should any items require urgent attention, shut down the genset immediately and rectify the fault, using skilled assistance if required.
5. Activate the PCCP's Engine menu and check the engine lubrication oil pressure (consult the engine Operation and Maintenance Manual for correct value). Check the engine speed and ensure that the engine is running near to nominal speed. The speed governing should be stable with no tendency to hunt. Make careful observations of any sign of a malfunction of the engine, alternator and auxiliary systems.
Engine operating speed is adjusted at the factory to 1500 RPM at full load (50 Hz Sets) and 1800 RPM at full load (60 Hz Sets).
The no-load operating speed is within 2 to 2.5 Hz higher than the full load operating speed.
6. Activate the PCCP's GEN menu and check the alternator output voltage and frequency. Refer to the alternator Installation, Service and Maintenance Manual.
7. Check the engine / associated pipe-work, including the exhaust system, for leaks. In the event of a fuel or exhaust leak, shut down the genset immediately.

Caution: *Take extreme care when working on a hot exhaust system. In case of a fuel or lubricating oil leak, the spilled fluid should be absorbed using a proprietary material (Fullers Earth granules or similar).
Sawdust should not be used, as this will create a fire hazard.*

8. After a short period of running off-load (between five and fifteen minutes), shut down the Genset by turning the Mode switch to the Off position. A controlled shutdown is affected by the PCCP, and this may include a short cooling down run.

6.10.3 On-load Initial Run

WARNING: **DO NOT ATTEMPT TO START THE GENERATOR UNTIL IT IS SAFE TO DO SO. WARN ALL OTHERS IN THE VICINITY THAT THE SET IS AVAILABLE AND ABOUT TO START.**

Caution: *Ensure Pre-start Checks have been carried out.*

If the genset is in order on the Off-load initial run, arrange for an On-load (mains failure) test run. This should be performed during a non-critical period, as it may be necessary to stop the genset during the test.

Caution: *One operator should be in complete charge, or working under the direction of someone who is. Remember that, upon starting the engine, cables and switchgear will become energised, possibly for the first time. Furthermore, equipment that does not form part of the generator installation may become electrically charged. Only authorised and competent personnel should carry out this work.*

Caution: *Do not use an Emergency Stop switch to shutdown an engine, unless a serious fault develops.*

1. Initiate an engine start as follows:
 - a) **Manual Start Gensets** — at the PCCP, set the Mode switch to Run. The engine starts and runs up to speed
 - b) **Automatic / Remote Start Gensets** — at the PCCP, set the Mode switch to Auto and initiate a genset start from the remote location. The engine should start and run up to speed
 - c) **Automatic Mains Fail Gensets**— at the PCCP, set the Mode switch to Auto and initiate a manual start from the remote location. The engine will start and run up to speed

2. On **Manual Start Gensets**, the circuit breaker will have to be closed once the generator has attained its operating speed and voltage. The PCCP's automatic synchroniser will prevent closure of the breaker until full synchronisation is effected. If required, the PCCP's Gen menu can be checked for sync indications.
3. Observe the genset and power system performance closely. In the unlikely event of an engine fire, activate a Fire Break Glass unit (if fitted). This will result in an immediate shutdown and fire alarm indications.

<p>WARNING: PERSONAL SAFETY MUST COME BEFORE ENGINE SAFETY. THE ABOVE PROCEDURE IS TO BE CARRIED OUT ONLY IF THE SITUATION ALLOWS IT. ALWAYS OBEY INSTRUCTIONS GIVEN BY EMERGENCY SERVICE PERSONNEL, AND OBSERVE LOCAL FIRE REGULATIONS AT ALL TIMES.</p>
--

4. Allow the genset to run for fifteen minutes on-load to check initial readings and functions of the engine. Engine parameters can be checked on the PCCP's Engine menu and power parameters on the analogue meters and the Gen menu.
5. Oil pressure should be maintained after an initial drop and should stabilise as the engine temperature stabilises. The pressure should always be within the manufacturer's specification.
6. Engine temperature should rise rapidly and then stabilise after a few minutes. The normal running temperature should be within the range 176°F to 203°F (80°C to 95°C).
7. Voltage should be maintained within $\pm 2\%$ for stable load conditions.
8. Frequency should be maintained within 2 Hz for all stable loads between zero and full-load.
9. Check all engine systems for leaks. If any leaks are detected, the genset should be shut down by setting Mode switch to Off, and the leaks rectified. If the leak is serious or may cause immediate danger, use an Emergency Stop switch to shut down the engine.
10. On satisfactory completion of the test the generator can be signalled to stop (set the Mode switch to Off) and the mains supply can be returned. The genset will open the circuit breaker and automatically be put into a cooling run off-load before performing a controlled shutdown.
11. Complete a Commissioning Form, if required.

6.10.4 Maintenance Test Run

On completion of all maintenance, and **only when it is safe to run the generator**, a Test Run should be carried out. This test should be performed at least weekly on engines that have not been run.

Note: *The control system (i.e. the PCCP) will make up to three start attempts automatically, and will indicate a Shutdown if the third attempt fails. If a fault condition arises, running faults will be displayed on the PCCP. The indications should be noted down to assist in fault finding, as detailed in Section 7.*

To carry out a test run, perform the following:

1. Re-connect all supplies to the generator.
2. Re-connect the plant battery.
3. Check the output of the battery charger (if fitted).
4. Perform a self test on the PCCP by pressing and holding the Self Test membrane switch. Ensure that the PCCP illuminates all LEDs and cycles through all Warning and Shutdown messages. Release the switch at end of test cycle.

WARNING: DO NOT ATTEMPT TO START THE GENERATOR UNTIL IT IS SAFE TO DO SO.
--

5. Start the genset as follows:
 - a) Set the fuel shut-off lever to the Work position (open)
 - b) On Manual Start gensets, turn the Mode switch to the Run position and the engine should start automatically
 - c) On Automatic / Remote Start gensets ensure that the Mode switch is set to the Auto position. Initiate a genset start by providing a remote start signal

Caution: <i>If the genset fails to start after three attempts, and the PCCP indicates a Shutdown, the fault must be cleared before any further start attempts are made. Refer to Section 7 for fault finding.</i>
--

6. If the genset fails to start, as detailed above, reset the control system as follows:
 - a) Return the Mode switch to the Off position
 - b) Identify and **clear the fault before any further start attempts are made**
 - c) Press the Reset button
 - d) Select Run or Auto, as required, and repeat the above starting procedure
7. With the genset running, activate the Engine menu on the PCCP and check the following engine parameters:
 - a) Oil pressure should be maintained after an initial drop. The pressure should always be within the manufacturer's specification
 - b) Engine temperature should rise rapidly and then stabilise after a few minutes. The normal running temperature should be within the range 176°F to 203°F (80°C to 95°C)
8. **Load the genset to at least 30% rated kilowatt output** and observe the performance closely. Avoid off-load running for extended periods.

9. Check the engine and associated pipework, including the exhaust system, for leaks. In the event of an exhaust leak, the genset should be shut down immediately and measures taken to ensure personal safety. Observe the 'Exhaust Gas Hazards' safety requirements listed in Section 1.

WARNING: RISK OF TOXIC FUMES

Caution: <i>Take extreme care when working on a hot exhaust system. In case of a fuel or lubricating oil leak, the spilled fluid should be absorbed using a proprietary material (Fullers Earth granules or similar). Sawdust should not be used, as this will create a fire hazard.</i>

10. Activate the Gen menu on the PCCP and check the generator output by observing the analogue meters and the more detailed information on the digital display:
 - a) Voltage should be maintained within $\pm 2\%$ for stable load conditions
 - b) Frequency should be maintained within 2 Hz for all stable loads between zero and full-load

Note: *If required, the Phase Select switch can be used to select alternative phase data on the analogue voltmeter and ammeter.*

11. On satisfactory completion of the test, open the genset circuit breaker to return the load to the mains supply.
12. This operation applies to the initial start-up only. Confirm correct operation of the Emergency Stop facility as follows:
 - a) Press the Emergency Stop push-button on the PCCP and ensure that the engine shuts down immediately, without a cooling down run
 - b) When the engine has stopped rotating, pull the Emergency Stop push switch to unlatch the switch
 - c) Return the Mode switch to Off
 - d) Press the Reset membrane switch
13. As soon as possible after the Emergency Stop, set the Mode switch on the PCCP to Run or Auto as required for a restart. Ensure that the genset starts and runs and that the engine temperature stabilises. Avoid off-load running for extended periods.
14. If plant room Emergency Stop push switches are provided, repeat the above two paragraphs for each of the push buttons provided, always allowing time for the engine temperature to stabilise. Bear in mind that shutting the engine down without a cooling down run can cause overheating, so space the checks accordingly.

Note: *The requirement for further checks on the Emergency Shutdown system will depend on generator usage. Contact an authorised Service Department for a site-specific recommendation.*

15. Perform the following procedure to shut down the genset, and ensure that the engine completes a short cooling run before shutting down:
 - a) On Manual Start Gensets, turn the Mode switch to the Off position
 - b) On Automatic/Remote Start Gensets remove the Remote Start signal
16. Return the genset to its normal operating mode as required.
17. Keep a record of all maintenance work carried out.

SECTION 7 – TROUBLESHOOTING

7 Troubleshooting

7.1 Introduction

Fault diagnosis charts are provided in this section to assist in locating and identifying the possible causes of faults in the genset system.

The PCCP displays faults and warnings by illuminating its lamps, and also displays numbered fault messages on its digital display. These are detailed in the PCCP Fault Finding Charts. If an operating fault occurs, first check the PCCP indications against these charts. If the problem cannot be resolved, continue with the General Fault Finding Charts that contain basic troubleshooting procedures.

The Engine Operation and Maintenance Manual and the Alternator Installation, Service and Maintenance Manual contain their own fault finding charts which identify the possible causes of their respective faults.

Many common faults are highlighted in this section.

7.2 Safety Considerations

Fault finding work, particularly in confined areas, should be carried out by two engineers working together. Read, understand, and comply with all safety precautions listed in Section 1 – Preliminary and Safety – and observe all instructions and precautions throughout this manual and the Health and Safety Manual 3553.

High voltages are present within the genset output box when the generator is running.

WARNING: DURING TESTING IT MAY BE NECESSARY TO REMOVE COVERS TO ADJUST CONTROLS EXPOSING 'LIVE' TERMINALS OR COMPONENTS. ONLY PERSONNEL QUALIFIED TO PERFORM ELECTRICAL SERVICING SHOULD CARRY OUT TESTING AND/OR ADJUSTMENTS. REFIT ALL ACCESS COVERS AFTER ADJUSTMENTS HAVE BEEN COMPLETED.

The installation of a genset can be designed for remote starting. When troubleshooting a genset that is shutdown ensure that the set cannot be accidentally re-started. Refer to Section 6.2 - Locking the Genset Out of Service.

WARNING: HIGH VOLTAGES ARE PRESENT WHEN THE GENSET IS RUNNING. DO NOT OPEN THE OUTPUT BOX WHILE THE GENSET IS RUNNING

WARNING: SOME PANEL INTERNAL COMPONENTS MAY HAVE LIVE EXPOSED TERMINATIONS EVEN IF THE GENSET IS NOT RUNNING. ISOLATE ALL EXTERNAL ELECTRICAL SUPPLIES PRIOR TO ACCESS OF THE CONTROL PANEL.

WARNING: CONTACTING HIGH VOLTAGE COMPONENTS CAN CAUSE SEVERE PERSONAL INJURY OR DEATH BY ELECTROCUTION. KEEP THE OUTPUT BOX COVERS IN PLACE DURING TROUBLESHOOTING. ONLY PERSONNEL QUALIFIED TO PERFORM ELECTRICAL SERVICING SHOULD CARRY OUT TESTING AND/OR ADJUSTMENTS.

Caution: Always disconnect a battery charger from its AC source before disconnecting the battery leads. Failure to do so can result in voltage spikes high enough to damage the DC control circuits of the genset.

WARNING: VENTILATE BATTERY AREA BEFORE WORKING ON OR NEAR BATTERY – WEAR GOGGLES – STOP GENSET AND DISCONNECT CHARGER BEFORE DISCONNECTING BATTERY CABLES – DISCONNECT NEGATIVE (-) LEAD FIRST AND RECONNECT LAST.

WARNING: IGNITION OF EXPLOSIVE BATTERY GASES CAN CAUSE SEVERE PERSONAL INJURY OR DEATH. ARCING AT BATTERY TERMINALS, LIGHT SWITCH OR OTHER EQUIPMENT, FLAME, PILOT LIGHTS AND SPARKS, CAN IGNITE BATTERY GAS. DO NOT SMOKE, OR SWITCH TROUBLE LIGHT ON OR OFF NEAR BATTERY. DISCHARGE STATIC ELECTRICITY FROM BODY BEFORE TOUCHING BATTERIES, BY FIRST TOUCHING A GROUNDED METAL SURFACE.

WARNING: ACCIDENTAL STARTING OF THE GENSET WHILE WORKING ON IT CAN CAUSE SEVERE PERSONAL INJURY OR DEATH. PREVENT ACCIDENTAL STARTING BY DISCONNECTING THE STARTING BATTERY LEADS (NEGATIVE [-] FIRST).

7.3 Fault Finding

Should a fault condition occur during operation, follow the procedures in the following tables to locate and correct the problem. For any symptom not listed, contact an Authorised Service Centre for assistance.

Before starting any fault finding, ensure that the following basic checks are carried out:

- All switches and controls are in their correct positions
- The fuel oil level is correct
- The lubricating oil level is correct
- The coolant level is correct
- The radiator matrix is free from obstruction
- The battery charge condition is satisfactory and the connections are secure
- The genset electrics and alternator connections are secure
- The panel connections are secure
- The protection circuits have been reset
- Blown fuses have been replaced
- Tripped contactors or circuit breakers have been reset

WARNING: MANY TROUBLESHOOTING PROCEDURES PRESENT HAZARDS THAT CAN RESULT IN SEVERE PERSONAL INJURY OR DEATH. ONLY QUALIFIED SERVICE PERSONNEL WITH KNOWLEDGE OF FUELS, ELECTRICITY, AND MACHINERY HAZARDS SHOULD PERFORM SERVICE PROCEDURES.
REVIEW SAFETY PRECAUTIONS LISTED WITHIN SECTION 1 - PRELIMINARY AND SAFETY SECTION - OF THIS MANUAL TOGETHER WITH THE HEALTH AND SAFETY MANUAL 3553.

7.4 Status Indicators

7.4.1 Not in Auto Indicator

This red indicator flashes continuously when the Mode switch is in the Off position (Figure 7-1).

7.4.2 Shutdown Status Indicator

This red indicator is lit whenever the control detects a shutdown condition. Shutdown faults are latched. After the condition has been corrected, the Shutdown indicator can be reset by turning the Mode switch to the Off (O) position, and pressing the Reset button. In the Auto position, Shutdown faults can be reset by removing the remote start input and then cycling the remote reset input.

Note: *Emergency Stop Shutdown status (code 102) can only be reset at the PCCP front panel.*

7.4.3 Warning Status Indicator

This yellow indicator is lit whenever the control detects a warning condition. After the condition has been corrected, the Warning indicator can be reset by pressing the Reset button. (It is NOT necessary to stop the genset). In Auto mode, warning indicators can also be reset by cycling the remote reset input after the condition has been corrected.

7.5 Reading Fault Codes

The fault code/message will be displayed in the two line digital display (Figure 7-1).

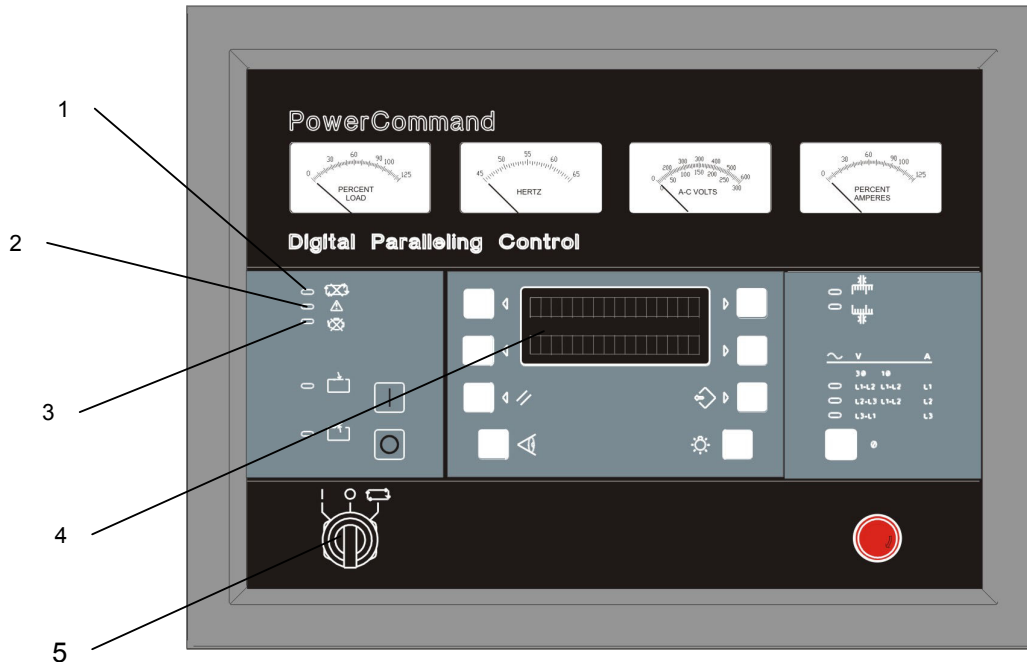

Figure 7-1 Front Panel

1. Non-Automatic Indicator
2. Warning Indicator
3. Shutdown Indicator
4. Digital Display
5. Mode Switch (Run/Off/Auto)

7.5.1 Engine Starting Faults

Symptom	Possible Cause	Remedy
Engine does not crank with Mode switch set to correct position.	Shutdown alarm condition active	a) Reset shutdown alarm after clearing fault
	AIR START Low starting air pressure	a) Check compressor, reducing valve and start solenoid
	ELECTRIC START Starting batteries discharged or battery life span exceeded	a) Check electrolyte for correct specific gravity and level b) Check charger function c) Test, and renew batteries if required
	Air start or electric starter motor pinion locked or not engaging (if applicable)	a) Turn flywheel with barring gear to release pinion and/or remove motor b) Clean and grease pinion
	Damaged teeth on motor pinion or flywheel starter ring	a) Repair or renew start motor b) Seek qualified technical advice
	Coolant in one or more cylinders	a) Refer to Engine Manual
	Incorrect grade of oil	a) Refill with correct viscosity
Engine cranks but fails to start (after a predetermined number of start attempts), OR engine cranks and starts but fails to continue to run.	Fuel tank empty	a) Fill to required level
	Fuel solenoid faulty	a) If jammed, free up b) Renew coil or entire solenoid valve
	Waxed fuel / blocked filters	a) Change filters and switch heaters on
	Engine too cold	a) If heaters are fitted, ensure they are operative.
	No fuel at pump / injector unit(s)	a) Check fuel supply pump b) Ensure all bleed screws are closed c) Pressurise the fuel system d) Bleed off any air
	Air filter clogged	a) Remove & clean / renew
	Speed probe faulty	a) Renew probe
	Actuator malfunctioning	a) Install new actuator
	No fuel control output from panel	a) Check fuses/relays
	Over-speed trip operated	a) Find cause and rectify b) Reset trip
Engine starts but fails to run up to speed, OR engine loses speed when on load.	Air in fuel	a) Bleed air from fuel system
	Fuel tank level low	a) Fill to required level
	Obstruction in spill return line	a) Ensure all valves are open
	Fuel filters choked	a) Renew filters
	Air cleaner blocked	a) Clean / renew air cleaner
	High exhaust gas back-pressure	a) Check for obstruction such as collapsed silencer or trunking
	Turbocharger faulty	a) Seek qualified technical help
	Load step excessive	a) Reduce load steps
Engine overloaded	a) Reduce load level	

7.5.2 Engine Running Faults

Symptom	Possible Cause	Remedy
Excessive black smoke	Engine overloaded	a) Reduce load level
	Blocked air cleaner	a) Clean / renew air cleaner
	High exhaust gas back pressure	a) Check for obstruction such as collapsed silencer or trunking
	Injectors / pumps require servicing	a) Refer to Engine Manual
	Turbocharger requires servicing	a) Refer to Engine Manual
	Excessive light load running	a) Ensure correct loading
	Overheating	a) See Engine Overheats
Excessive white smoke with engine misfiring	Incorrect inlet and or exhaust valve clearances	a) Refer to Engine Manual
	Damaged valves / seats	a) Refer to Engine Manual
	Faulty pump / injectors	a) Refer to Engine Manual
	Excessive light load running	a) Ensure correct loading
	Turbocharger turbine seal faulty	a) Refer to Engine Manual
	Contaminated fuel	a) Check fuel system for contaminants b) Discard fuel and renew if necessary
Excessive blue smoke	Worn pistons / piston rings - liners / valve stems or valve guides	a) Refer to Engine Manual
	Excessive light load running	a) Ensure correct loading
	Turbocharger compressor seal faulty	a) Refer to Engine Manual
	High engine oil level	a) Reduce to correct level
	Contaminated fuel	a) Check fuel system for contaminants b) Discard fuel and renew if necessary
Engine overheats	Radiator air matrix choked	a) Clean radiator air matrix
	Radiator fan not turning	a) Test circuitry - renew motor if necessary b) Check fan belt and renew if necessary
	Loss of coolant	a) Top-up to required level b) Ascertain reason for loss and rectify
	Cooling pumps faulty	a) Refer to Engine Manual
	Ventilation louvres not open	a) Open louvres
Engine Overspeeds	Actuator faulty	a) Refer to Engine Manual
	Restricted fuel spill return line	a) Check for obstruction b) Ensure that all valves are open
Engine will not stop / stops very slowly	Fuel drain-off solenoid valve faulty	a) If faulty, renew coil or renew whole unit
	Worn injector valves	a) Overhaul - renew injectors
	Actuator / drain off seals faulty	a) Renew seals / renew actuator

Symptom	Possible Cause	Remedy
Engine speed unstable	Actuator faulty	a) Overhaul or renew
	Restriction in spill return line	a) Check for obstruction b) Ensure all valves are open
	Restricted exhaust system	a) Check for obstruction such as collapsed silencer or trunking
	Disrupted screen connection from probe	a) Carry out a continuity test to locate the fault
Excessive vibration due to engine misfire	Pump injector unit(s) faulty	a) Refer to Engine Manual
	Inlet or exhaust valves sticking	a) Lubricate with half-and-half mixture of fuel oil and lubricating oil
	Badly worn valve stems and / or guides	a) Refer to Engine Manual
	Burned valve seats / valves	a) Refer to Engine Manual
Rotary vibration	Alternator / engine misaligned	a) Contact your Authorised Dealer
	Coupling faulty	a) Renew coupling b) Contact your Authorised Dealer
	Alternator shaft distorted	a) Contact your Authorised Dealer
No speed control - trim	Speed control faulty	a) Renew control unit b) Contact your Authorised Dealer
	Disrupted connections	a) Check and test connections
Engine stops due to low oil pressure	Low oil level	a) Top up oil to correct level b) Call your distributor to service the engine lubrication system
	Choked filter or dirty oil cooler	a) Change filter / clean cooler
	Internal or external oil leakage	a) Determine by inspection and rectify
	Oil pressure relief valve faulty or requiring adjustment	a) Overhaul or adjust
	Oil pump faulty	a) Remove, inspect b) Overhaul or renew
	Worn engine bearings	a) Contact your Authorised Dealer
Engine stops due to high temperature.	Low coolant level	a) Top up coolant b) Check for leaks
	Radiator matrix choked	a) Clean radiator matrix
	Radiator fan motor faulty	a) Test circuitry b) Renew motor if necessary
	Cooling pumps faulty	a) Check pump drives and impellers for wear b) Overhaul or renew
Discharged battery	Faulty charge alternator or battery charger	a) Rectify fault or renew charge alternator /battery charger
Engine stops due to fuel starvation	Low fuel level, fuel system leakage or fuel pipe blockage	a) Check the fuel system for any of these faults

7.5.3 Electrical Output Faults

Symptom	Possible Cause	Remedy
Earth fault trip	Insulation in terminal box or cables faulty	a) Test all cables for earth fault b) Locate faulty section c) Renew or repair section of cable
	Earth fault in alternator stator windings	a) Contact your Authorised Dealer
	Current transformer(s) faulty	a) Test transformers for continuity and earth fault b) Replace if faulty
	Earth Fault relay malfunction	a) Replace relay
	Multiple neutral earths	a) Contact your Authorised Dealer
Voltage does not build up to rated value	Low residual or incorrect polarity between exciter output and generator field	a) Field flashing is required. Refer to Alternator Manual for these instructions
	Exciter defective	a) Test Exciter output and refer to Alternator Manual
	Short-circuited rotating diodes	a) Test and renew defective diodes b) Refer to Alternator Manual
	Open circuit connection to main field	a) Test for and locate fault in field b) Make good or contact your Authorised Dealer
	Prime mover not up to required speed	a) Check fuel filters
Poor regulation	Contact your Authorised Dealer	
Poor voltage stability	Contact your Authorised Dealer	
Voltage recovery slow with load change	Contact your Authorised Dealer	
Paralleled generators do not share real kW load equally	Contact your Authorised Dealer	
Output voltage falls off as load increases	Contact your Authorised Dealer	
Output voltage rises as load increases	Contact your Authorised Dealer	
System does not start on mains failure	Mode switch on Mains Failure Unit not in Auto	a) Set Mode switch to Auto
	Global Emergency Stop button on Common Control Unit depressed	a) Release Emergency Stop button
	No sets available	a) Check set status

Symptom	Possible Cause	Remedy
Set does not supply load	Defective circuit breaker or coil	a) Renew coil or entire breaker
	Alternator voltage low / high	a) Ascertain reason for wrong voltage and take the required action
	Faulty synchronisation	a) Retry b) Contact your Authorised Dealer
	Fault at Common Control Unit	a) Contact your Authorised Dealer
	Set switched to LOCAL on Set Management Controller	a) Check switch setting
System does not supply load	Defective circuit breaker interlocks	a) Contact your Authorised Dealer
	Circuit breaker trip unit requires resetting	a) Reset or Contact your Authorised Dealer
	Fault at Mains Failure Unit	a) Contact your Authorised Dealer
Mains does not return automatically	Mode switch on MFU in Manual Mains Return or Test on Load. Mains supply not achieving MFU setting	a) Set Mode switch to Auto Mains Return position

7.5.4 Control System Faults

SYMPTOM	POSSIBLE CAUSE	CORRECTIVE ACTION
Control does not power-up when the Mode switch is set to Run or the Self-test switch is pressed	There is no DC power to the control	<ul style="list-style-type: none"> a) Check the battery electrolyte level and specific gravity b) Check terminals are clean and tight c) Check Fuse 1 on the engine interface board d) Contact an Authorised Service Centre
Warning, Shutdown, and Non-Automatic lamps are not lit. Digital display shows main menu or selected menu	None	<ul style="list-style-type: none"> a) Indicates all engine systems are normal b) No corrective action required
Non-Automatic lamp flashes	Mode switch is not in the Auto position. This will prevent automatic starting	<ul style="list-style-type: none"> a) Move the Mode switch to the Auto position for automatic operation b) None Automatic lamp stops flashing
MESSAGE: IDLE MODE 101 — INDICATION ONLY Engine continues to operate at reduced RPM	PCCP idles the engine at start up if jacket temperature is below 140°F (40°C), and continues to do so until this temperature is reached. PCCP idles the engine during cooling run before shutting down. <i>The above conditions only apply to engines requiring these procedures to be set up</i>	<p>Indicates that the engine is operating in Idle mode.</p> <ul style="list-style-type: none"> a) When the genset is operating in the Run mode, grounding the engine idle input causes generator build-up to be inhibited and the engine to be governed at idling speed b) When ground is removed from this input, the genset returns to normal speed and voltage c) When the engine idle function is enabled, the control automatically sets lower oil pressure warning and shutdown trip points to reflect the lower operating speed d) When the engine idle function is removed and the genset reverts to normal operating speed, the control automatically resets the oil pressure warning and shutdown trip points to the normal settings
Shutdown lamp lights MESSAGE: EMERGENCY STOP 102 — SHUTDOWN Engine shuts down and will not crank	Local or remote Emergency Stop Operated	<p>To Reset:</p> <ul style="list-style-type: none"> a) Pull the switch and allow it to un-latch b) Turn the Mode switch to Off c) Press the Reset switch d) Select Run or Auto as required
Warning lamp lights MESSAGE: LOW OIL PRESSURE 200 — WARNING Engine continues to operate	Indicates that the engine oil pressure has dropped to an unacceptable level. Possibly due to high oil temperature, low oil level, dirty filters, dirty cooler, relief valve failure, potential oil pump failure, excessively worn engine bearings — eventual bearing failure	<ul style="list-style-type: none"> a) The engine must be stopped as soon as possible to prevent serious damage. If the engine can be stopped, do so b) If the generator is powering critical loads and cannot be shut down, wait until the next shutdown period then follow the next procedure, - Low Oil Pressure. Shutdown
Shutdown lamp lights MESSAGE: LOW OIL PRESSURE 201 — SHUTDOWN Engine shuts down	Indicates that the engine oil pressure has dropped below the shutdown trip point. The reason for this shutdown must be determined before restarting the engine. Check possible causes as in 200 — warning	<ul style="list-style-type: none"> a) Check all possible causes as in 200 —warning b) Rectify the problem c) Reset the control system and re-start d) Check engine running conditions under no load e) Contact an Authorised Service Centre if the problem persists

SYMPTOM	POSSIBLE CAUSE	CORRECTIVE ACTION
<p>Warning lamp lights MESSAGE: OIL PRES SENDER 204 — WARNING</p>	<p>Indicates that the engine oil pressure sender is not functioning correctly</p>	<p>a) Check that the engine oil pressure sender is properly connected b) Contact an Authorised Service Centre if problem persists</p>
<p>Warning lamp lights MESSAGE: LOW COOLANT TEMP 210 — WARNING The genset is in standby mode but is not operating. Warning occurs when the engine coolant temperature is 21°C (70°F) or lower. <i>Note: In applications where the ambient temperature falls below 4°C (40°F), Low Engine Temp may be indicated even though the coolant heaters are operating</i></p>	<p>Indicates that the engine coolant heater is not operating or is not circulating coolant</p>	<p>Check for the following conditions: a) Coolant heater not connected to the power supply b) Check for blown fuse or disconnected heater cord and correct as required c) Check for low coolant level and replenish if required d) Look for possible coolant leakage points and repair as required e) Contact an Authorised Service Centre if none of above Note: This signal wakes-up the PCCP from the Standby condition</p>
<p>Warning lamp lights MESSAGE: HIGH COOLANT TEMP 211 — WARNING Engine continues to operate</p>	<p>Indicates that the engine has begun to overheat and the coolant temperature has risen to an unacceptable level: 101°C (215°F) – Standby / 97°C (207°F) – Primary.</p> <p>If the generator is powering non-critical and critical loads and cannot be shutdown — reduce the load if possible by turning off non-critical loads.</p> <p>Check air inlets and outlets and remove any obstructions to airflow</p>	<p>If the engine can be stopped. a) Allow the engine to cool before checking the coolant level and replenish if required b) Determine reason for coolant loss and rectify c) Check coolant pump & pump drive d) Check radiator matrix for air-born debris and clean if required or if heat exchanger is employed check raw water pump and raw water supply e) Check fan belt and / or fan motor circuitry f) Access the Coolant Temp menu prior to clearing the fault g) Run engine on no load test after rectifying the fault</p>
<p>Shutdown lamp lights MESSAGE: HIGH COOLANT TEMP 212 — SHUTDOWN Engine shuts down</p>	<p>Indicates that the engine has overheated - coolant temperature has risen above the shutdown trip point: 101°C (215°F) – Standby / 97°C (207°F) – Primary</p>	<p>Allow the engine to cool down completely before proceeding with the following checks: a) Check the coolant level and replenish if low b) Look for coolant leakage and repair if necessary c) Check for obstructions to cooling airflow and correct as necessary d) Carry out all checks as in 211 — warning e) Run engine on no load test after rectifying the fault</p>
<p>Warning lamp lights MESSAGE: ENG COOLANT SENDER 213 — WARNING</p>	<p>Indicates that the resistance of the coolant temperature sender is out of range</p>	<p>a) Check the sender. Resistance should be 500 to 2k ohm b) If faulty — fit new sender</p>

SYMPTOM	POSSIBLE CAUSE	CORRECTIVE ACTION
<p>Shutdown lamp lights MESSAGE: LOW COOLANT LVL 214 — WARNING Engine shuts down OR LOW COOLANT LVL 215 — SHUTDOWN</p>	<p>Indicates that the engine coolant level has fallen below the trip point. Allow the engine to cool down completely before proceeding. <i>Note: This signal wakes up the PCCP.</i> (Low Coolant Warning only)</p>	<ul style="list-style-type: none"> a) Check the coolant level and replenish if low b) Look for possible coolant leakage points and repair if necessary c) Reset the control system and restart after locating and correcting the problem d) Contact Authorised Service Centre if problem persists e) LOW COOLANT LVL Shutdown will not occur if genset is in Idle mode
<p>Shutdown lamp lights MESSAGE: MAG PICKUP 220 — SHUTDOWN Engine shuts down</p>	<p>Indicates that the magnetic pick-up speed indication is not being sensed or does not match the genset output frequency</p>	<ul style="list-style-type: none"> a) Check that the pickup sensing head is clean b) Check cable for continuity and good screening c) Restart and check RPM on the digital display d) Contact an Authorised Service Centre if the problem persists
<p>Engine will not crank Shutdown lamp lights MESSAGE: FAIL TO CRANK 221 — SHUTDOWN</p>	<p>Indicates a possible fault with the control or starting system. Discharged or defective battery. Poor battery cable connections. Locked starter motor or damaged flywheel starter ring</p>	<p>Check for the following conditions:</p> <ul style="list-style-type: none"> a) Check fuse F3 on the Engine Interface Board b) Recharge or replace the battery c) Clean the battery cable terminals and tighten all connections including starter motor d) Contact an Authorised Service Centre for service of starter and starting system
<p>Shutdown lamp lights Engine Stops Cranking MESSAGE: OVERCRANK 222 — SHUTDOWN</p>	<p>Indicates a possible fuel problem or air induction problem: Fuel supply tank low level or contaminated fuel. Fuel filters choked. Waxed fuel. Air induction filters choked. Air shut-off valves operated</p>	<ul style="list-style-type: none"> a) Replenish fuel supply tank b) Renew fuel filters c) Ensure engine heaters are operating d) Clean/renew induction filters e) Reset air shut-off valves f) Reset the control system and restart after correcting the problem g) Contact an Authorised Service Centre if none of the above
<p>Engine runs and then shuts down Shutdown lamp lights MESSAGE: OVERSPEED 223 — SHUTDOWN</p>	<p>Indicates that the engine has exceeded its normal operating speed trip point.</p>	<ul style="list-style-type: none"> a) Contact an Authorised Service Centre
<p>Warning lamp lights MESSAGE: LOW DC VOLTAGE 230 — WARNING</p>	<p>Indicates that the battery voltage is below 24V DC. (12V DC for 12V battery) Discharged or defective battery. Battery charger fault/fuse</p>	<ul style="list-style-type: none"> a) Check the battery electrolyte level and specific gravity b) Repair battery charger c) Recharge or replace the battery d) Poor battery cable connections e) Clean the battery cable terminals and tighten all connections f) Contact an Authorised Service Centre if none of the above
<p>Warning lamp lights. MESSAGE: HIGH DC VOLTAGE 231 — WARNING</p>	<p>Indicates that the battery voltage exceeds 32V DC (16V DC for 12V battery)</p>	<ul style="list-style-type: none"> a) Contact an Authorised Service Centre
<p>Warning lamp lights MESSAGE: WEAK BATTERY 232 — WARNING Engine continues to run</p>	<p>Indicates the battery voltage dropping below 60% of nominal for two seconds, during starting. Discharged or defective battery</p>	<ul style="list-style-type: none"> a) See Warning Message 230 LOW DC VOLTAGE

SYMPTOM	POSSIBLE CAUSE	CORRECTIVE ACTION
<p>Warning lamp lights MESSAGE: LOW FUEL DAY 240 — WARNING</p>	<p>Indicates that the day tank fuel supply is running low</p>	<p>a) Check the fuel supply and replenish as required <i>Note: This signal wakes up the PCCP</i></p>
<p>Warning lamp lights. MESSAGE: LOW FUEL 241 — WARNING</p>	<p>Indicates that the fuel supply is running low</p>	<p>a) Check the fuel supply and replenish as required</p>
<p>Shutdown lamp lights. MESSAGE: EEPROM ERROR 250 — SHUTDOWN</p>	<p>Indicates PCCP memory error. Data corruption of critical operating parameters</p>	<p>a) Contact an Authorised Service Centre</p>
<p>Warning lamp lights. MESSAGE: EEPROM ERROR 251 — WARNING or 252 — WARNING Engine continues to run</p>	<p>Indicates PCCP memory error. Data corruption of non-critical operating parameters</p>	<p>a) Contact an Authorised Service Centre</p>
<p>Shutdown lamp lights. MESSAGE: RACK POSITION 260 — WARNING</p>	<p>QST30 SERIES ONLY. Indicates that one, or both, of the fuel racks is not at the commanded position.</p>	<p>a) Check fuel pump connections b) Check left and right actuator fuses (A38-F1 & F2) on the Governor Output Module c) Contact an Authorised Service Centre</p>
<p>Shutdown lamp lights. MESSAGE: CUSTOMER FAULT 1 260 — SHUTDOWN <i>(not applicable for QST30 series)</i> or GROUND FAULT 261 — SHUTDOWN or RUPTURE BASIN 262 — SHUTDOWN or HIGH GEN TEMP 263 — SHUTDOWN Engine shuts down</p>	<p>When any one of these customer defined inputs is closed to ground, the corresponding fault message is displayed. The nature of the fault is an optional customer selection. These fault functions can be programmed to initiate a Shutdown or a Warning. Customer fault 261 or 262 input can wake-up the control if it is not operating. As indicated by the Shutdown lamp, a shutdown response has been pre-selected. <i>Note: Customer fault messages are editable. The message displayed for the code shown (260 to 263) may have been edited and will not appear as shown in this table.</i> Note: for QST30 series the code 260 is reserved for the RACK POSITION fault and is not available as Customer Fault 1.</p>	<p>a) Contact an Authorised Service Centre</p>

SYMPTOM	POSSIBLE CAUSE	CORRECTIVE ACTION
<p>Warning lamp lights. MESSAGE: CUSTOMER FAULT 1 260 — WARNING <i>(not applicable for QST30 series)</i> or GROUND FAULT 261 — WARNING or RUPTURE BASIN 262 — WARNING or HIGH GEN TEMP 263 — WARNING</p>	<p>When any one of these customer defined inputs is closed to ground, the corresponding fault message is displayed. The nature of the fault is an optional customer selection. These fault functions can be programmed to initiate a Shutdown or a Warning. Customer fault 261 or 262 input can wake-up the control if it is not operating. As indicated by the Warning lamp, a shutdown response has been pre-selected. <i>Note: Customer fault messages are editable. The message displayed for the code shown (260 to 263) may have been edited and will not appear as shown in this table.</i> Note: for QST30 series the code 260 is reserved for the RACK POSITION fault and is not available as Customer Fault 1.</p>	<p>a) Contact an Authorised Service Centre</p>
<p>Shutdown lamp lights. MESSAGE: HIGH AC VOLTAGE 301 — SHUTDOWN Engine shuts down</p>	<p>Indicates that one of the phase voltages has exceeded 130% of nominal, or has exceeded 110% of nominal for ten seconds</p>	<p>a) Contact an Authorised Service Centre</p>
<p>Shutdown lamp lights. MESSAGE: LOW AC VOLTAGE 303 — SHUTDOWN Engine shuts down</p>	<p>Indicates that one of the phase voltages has dropped below 85% of nominal for ten seconds</p>	<p>a) Contact an Authorised Service Centre</p>
<p>Shutdown lamp lights. MESSAGE: UNDER FREQUENCY 313 — SHUTDOWN Engine shuts down</p>	<p>Indicates that engine speed has dropped below 90% of nominal for ten seconds <i>Note: Five seconds before Shutdown, a Load Dump signal is initiated</i></p>	<p>a) Contact an Authorised Service Centre</p>
<p>Warning lamp lights. MESSAGE: OVERCURRENT 320 — WARNING Engine continues to run</p>	<p>Indicates that the generator output current has exceeded 110% of rated value for 60 seconds</p>	<p>a) Contact an Authorised Service Centre</p>
<p>Shutdown lamp lights. MESSAGE: OVERCURRENT 321 — SHUTDOWN Engine shuts down</p>	<p>Indicates that the generator output current has exceeded 110% of rated value and that a PCCP time/current calculation has initiated an overcurrent Shutdown</p>	<p>a) Contact an Authorised Service Centre</p>
<p>Shutdown lamp lights. MESSAGE: SHORT CIRCUIT 322 — SHUTDOWN Engine shuts down</p>	<p>Indicates that the generator output current has exceeded 175% of rated value</p>	<p>a) Contact an Authorised Service Centre</p>

SYMPTOM	POSSIBLE CAUSE	CORRECTIVE ACTION
<p>Warning lamp lights. MESSAGE: OVERLOAD 330 — WARNING Engine continues to run</p>	<p>Indicates that the 3-phase power exceeds 105% of Standby (or 115% of Prime) rating. After five seconds the Load Dump output is activated. After 60 seconds the Overload warning is activated</p>	<p>a) Contact an Authorised Service Centre</p>
<p>Shutdown lamp lights. MESSAGE: REVERSE POWER 335 — SHUTDOWN</p>	<p>Indicates improper CT or PT phasing (Non-parallelleing units only)</p>	<p>a) Contact an Authorised Service Centre</p>
<p>Engine starts from the generator control panel but will not start automatically or from a remote panel. <i>Note: The Mode switch must be in the Auto position for automatic or remote starting</i></p>	<p>Check the control wiring between the remote switch and the PCCP</p>	<p>a) Contact an Authorised Service Centre</p>
<p>No AC output voltage</p>		<p>a) Contact an Authorised Service Centre</p>

Cummins Power Generation Ltd

Manston Park
Columbus Avenue
Manston, Ramsgate
Kent CT12 5BF
England

Main Office: *Tel:* +44 (0) 1843 255000

Fax: +44 (0) 1843 255902

Spares Dept: *Tel:* +44 (0) 1843 255575

Fax: +44 (0) 1843 255913

E-Mail cpg.uk@cummins.com

Web Sites www.cumminspower.com

www.cummins.com