



# Installation Manual

## Generator Set

with PowerCommand<sup>®</sup> 2100 Control

GGPA (Spec A-B)

GGPA (Spec A-B)

GGPC (Spec A-B)



# Table of Contents

---

1. IMPORTANT SAFETY INSTRUCTIONS .....	1
1.1 Warning, Caution, and Note Styles Used In This Manual .....	1
1.2 General Information .....	1
1.2.1 General Safety Precautions .....	2
1.3 Generator Set Safety Code .....	4
1.3.1 Moving Parts Can Cause Severe Personal Injury Or Death.....	4
1.3.2 Positioning of Generator Set.....	5
1.4 Electrical Shocks and Arc Flashes Can Cause Severe Personal Injury or Death.....	5
1.4.1 AC Supply and Isolation.....	6
1.4.2 Medium Voltage Equipment (601 V to 15 kV) .....	6
1.5 Fuel And Fumes Are Flammable .....	7
1.5.1 Spillage .....	7
1.5.2 Fluid Containment.....	7
1.5.3 Do Not Operate in Flammable and Explosive Environments .....	7
1.6 Exhaust Gases Are Deadly.....	8
1.6.1 Exhaust Precautions .....	8
2. INTRODUCTION .....	9
2.1 About This Manual .....	9
2.1.1 Additional Installation Manual Information .....	9
2.2 Schedule of Abbreviations .....	10
2.3 Related Literature .....	11
2.4 After Sales Services.....	12
2.4.1 Maintenance.....	12
2.4.2 Warranty.....	12
2.4.3 How to Obtain Service .....	12
3. SPECIFICATIONS .....	13
3.1 Generator Set Specifications .....	13
4. SYSTEM OVERVIEW .....	15
4.1 Generator Set Components .....	15
4.2 Generator Set Rating .....	17
4.3 Engine.....	17
4.4 Sensors.....	17
4.5 Heaters .....	18
4.5.1 Heater Supply and Isolation.....	18
5. INSTALLATION OVERVIEW .....	19
5.1 Application and Installation .....	19
5.2 Safety Considerations.....	19
5.3 Standby Heating Devices.....	19
5.4 Product Modifications.....	20

6. INSTALLING THE GENERATOR SET .....	21
6.1 Location .....	21
6.2 Mounting .....	22
6.3 Access to Set.....	23
6.4 Vibration Isolator Installation.....	23
7. MECHANICAL CONNECTIONS .....	27
7.1 Overview .....	27
7.2 Fuel System.....	27
7.3 Fuel Lines Routing .....	27
7.4 Natural Gas/LPG Vapor/LPG Liquid Fuel System.....	28
7.5 Fuel Pressure.....	28
7.6 Check Gas Leaks and Correct.....	29
7.7 Exhaust System .....	29
7.8 Ventilation and Cooling .....	32
7.9 Vents and Ducts.....	32
7.10 Dampers .....	33
7.11 Radiator Set Requirements.....	33
8. DC CONTROL WIRING .....	35
8.1 PCCnet devices Belden cable .....	36
8.2 TB1 Remote Monitor / Control Connections.....	36
8.3 PCC 2100 TB1 Customer Connections .....	37
8.4 TB1 Customer Inputs .....	37
8.5 TB1 Customer Outputs .....	38
8.6 Switched B+.....	40
8.7 Run Relays (K10, K11, K12).....	40
9. AC ELECTRICAL CONNECTIONS .....	43
9.1 Transfer Switch .....	44
9.2 Generator Voltage Connections.....	45
9.3 Load Connections .....	46
9.4 Load Balancing .....	46
9.5 Current Transformers.....	46
9.5.1 CT Installation Requirements.....	46
9.6 Grounding .....	46
9.7 Coolant Heater Connection.....	49
9.8 Alternator Heater (Option).....	49
10. PRE-START PREPARATION.....	51
10.1 InPower Service Tool General Information.....	51
10.1.1 InPower Adjust Mode.....	51
10.1.2 InPower Capture File Description .....	51
10.2 Electrical System .....	51
10.3 Battery Connections.....	52
10.4 Controller Configuration Relays.....	52
10.5 Adjust Menu .....	54

10.5.1 Adjusting Values/Parameters.....	56
10.5.2 Adjust Submenus.....	56
10.6 Starting.....	56
11. INSTALLATION CHECKLIST.....	57
12. MANUFACTURING FACILITIES.....	59
APPENDIX A. GGPA/B/C WIRING DIAGRAM WITH POWERCOMMAND 2100 CONTROL.....	61
APPENDIX B. WIRING DIAGRAMS.....	69
APPENDIX C. OUTLINE DRAWINGS.....	81
C.0 Outline Drawings.....	82
C.1 Outline Drawing 0500-5070 (F177).....	83
C.2 Outline Drawing 0500-5030 (F179).....	84
C.3 Outline Drawing 0500-3278 (Circuit Breaker).....	86
C.4 GGHE/GGHE Enclosure Outline Drawing 0500-4814 (F217).....	89
C.5 GGHE/GGHE Enclosure Outline Drawing 0500-4813 (F216).....	90
C.6 GGHE/GGHE Enclosure Outline Drawing 0500-3171 (F182).....	92
C.7 GGHE/GGHE Enclosure Outline Drawing 0500-3167 (F173).....	94
C.8 GGHE/GGHE Enclosure Outline Drawing 0500-3211 (F172).....	95

This page is intentionally blank.



# 1 Important Safety Instructions

---

**SAVE THESE INSTRUCTIONS** — This manual contains important instructions that should be followed during installation and maintenance of the generator set.

**Safe and efficient operation can be achieved only if the equipment is properly operated and maintained.** Many accidents are caused by failure to follow fundamental rules and precautions.

## 1.1 Warning, Caution, and Note Styles Used In This Manual

The following safety styles and symbols found throughout this manual indicate potentially hazardous conditions to the operator, service personnel, or the equipment.

### **DANGER**

*Indicates a hazardous situation that, if not avoided, will result in death or serious injury.*

### **WARNING**

*Indicates a hazardous situation that, if not avoided, could result in death or serious injury.*

### **CAUTION**

*Indicates a hazardous situation that, if not avoided, could result in minor or moderate injury.*

### **NOTICE**

**Indicates information considered important, but not hazard-related (e.g., messages relating to property damage).**

## 1.2 General Information

This manual should form part of the documentation package supplied by Cummins Power Generation with specific generator sets. In the event that this manual has been supplied in isolation please contact your authorized distributor.

### **NOTICE**

**It is in the Operator's interest to read and understand all Warnings and Cautions contained within the documentation relevant to the generator set, its operation and daily maintenance.**

## 1.2.1 General Safety Precautions

### WARNING

***Coolant under pressure.***

***Hot coolants under pressure can cause severe scalding.***

***Do not open a radiator or heat exchanger pressure cap while the engine is running. Let the engine cool down before removing the coolant pressure cap. Turn the cap slowly and do not open it fully until the pressure has been relieved.***

### WARNING

***Moving parts.***

***Can cause severe personal injury or death.***

***Make sure all protective guards are properly in place before starting the generator set.***

### WARNING

***Used engine oils.***

***Have been identified by some state and federal agencies to cause cancer or reproductive toxicity.***

***Do not ingest, breathe the fumes, or contact used oil when checking or changing engine oil. Wear protective gloves.***

### WARNING

***Operation of equipment.***

***Is unsafe when mentally or physically fatigued.***

***Do not operate equipment in this condition, or after consuming any alcohol or drug.***

### WARNING

***Substances in exhaust gases.***

***Have been identified by some state and federal agencies to cause cancer or reproductive toxicity.***

***Do not breathe in or come into contact with exhaust gases.***

### WARNING

***Flammable liquids.***

***Can cause fire or explosion.***

***Do not store fuel, cleaners, oil, etc. near the generator set.***

### WARNING

***Generator sets in operation mode emit noise.***

***Exposure to noise can cause hearing damage***

***Wear appropriate ear protection at all times.***

### WARNING

***Hot metal parts.***

***Can cause severe burns.***

***Avoid contact with the radiator, turbo charger, and exhaust system.***

**⚠ WARNING**

**Maintaining or installing a generator set.**

**Can cause severe personal injury.**

**Wear personal protective equipment such as safety glasses, protective gloves, hard hats, steel-toed boots, and protective clothing when working on equipment.**

**⚠ WARNING**

**Ethylene glycol.**

**Used as engine coolant, is toxic to humans and animals.**

**Clean up coolant spills and dispose of used antifreeze in accordance with local environmental regulations.**

**⚠ WARNING**

**Starting fluids, such as ether.**

**Can cause explosion and generator set engine damage.**

**Do not use.**

**⚠ WARNING**

**Accidental or remote starting.**

**Accidental starting of the generator set while working on it can cause severe personal injury or death.**

**To prevent accidental or remote starting while working on the generator set, disconnect the negative (-) battery cable at the battery using an insulated wrench.**

**⚠ CAUTION**

**Cleaning materials.**

**Loose cleaning materials can become entangled in moving parts or cause a fire hazard.**

**Make sure that all cleaning materials are removed from the generator set before operating the generator.**

**⚠ CAUTION**

**Combustible materials.**

**A build up of combustible materials under the generator set can present a fire hazard.**

**Make sure the generator set is mounted in a manner to prevent combustible materials from accumulating under the unit.**

**⚠ CAUTION**

**Accumulated grease and oil.**

**Can cause overheating and engine damage presenting a potential fire hazard.**

**Keep the generator set clean and make sure oil leaks are repaired promptly.**

**⚠ CAUTION**

**Maintenance and service procedures.**

**Service access doors on generator sets can be heavy.**

**Before performing maintenance and service procedures on enclosed generator sets, make sure the service access doors are secured open**

**⚠ CAUTION****Obstructions.**

*Articles left against the generator set or close by may restrict the air flow and cause over heating or a fire hazard.*

*Keep the generator set and the surrounding area clean and free from obstructions. Remove any debris from the set and keep the floor clean and dry.*

**NOTICE**

**Keep multi-class ABC fire extinguishers handy. Class A fires involve ordinary combustible materials such as wood and cloth. Class B fires involve combustible and flammable liquid fuels and gaseous fuels. Class C fires involve live electrical equipment. (Refer to NFPA No. 10 in applicable region.)**

**NOTICE**

**Stepping on the generator set can cause parts to bend or break, leading to electrical shorts, or to fuel, coolant, or exhaust leaks. Do not step on the generator set when entering or leaving the generator room.**

## 1.3 Generator Set Safety Code

Before operating the generator set, read the manuals and become familiar with them and the equipment. **Safe and efficient operation can be achieved only if the equipment is properly operated and maintained.** Many accidents are caused by failure to follow fundamental rules and precautions.

**⚠ WARNING*****Improper operation and maintenance.***

*Can lead to severe personal injury, or loss of life and property, by fire, electrocution, mechanical breakdown, or exhaust gas asphyxiation.*

*Read and follow all Safety Precautions, Warnings, and Cautions throughout this manual and the documentation supplied with your generator set*

**⚠ WARNING*****Lifting and repositioning of the generator set.***

*Incorrect lifting can result in severe personal injury, death, and/or equipment damage.*

*Lifting must only be carried out using suitable lifting equipment, shackles, and spreader bars, in accordance with local guidelines and legislation, by suitably trained and experienced personnel. For more information, contact your authorized distributor*

### 1.3.1 Moving Parts Can Cause Severe Personal Injury Or Death

- Keep your hands, clothing, and jewelry away from moving parts.
- Before starting work on the generator set, disconnect the battery charger from its AC source, then disconnect the starting batteries using an insulated wrench, negative (–) cable first. This will prevent accidental starting.

- Make sure that fasteners on the generator set are secure. Tighten supports and clamps; keep guards in position over fans, drive belts, etc.
- Do not wear loose clothing or jewelry in the vicinity of moving parts or while working on electrical equipment. Loose clothing and jewelry can become caught in moving parts.
- If any adjustments must be made while the unit is running, use extreme caution around hot manifolds, moving parts, etc.

### 1.3.2 Positioning of Generator Set

#### NOTICE

**On an enclosed generator set, the canopy doors must be locked before re-positioning, and they must remain locked during transportation and siting.**

The area for positioning the set should be adequate and level and the area immediately around the set must be free of any flammable material.

## 1.4 Electrical Shocks and Arc Flashes Can Cause Severe Personal Injury or Death

#### ⚠ WARNING

***Energized circuits.***

***Any work with exposed energized circuits with potentials of 50 Volts AC or 75 Volts DC or higher poses a significant risk of electrical shock and electrical arc flash. These silent hazards can cause severe injuries or death.***

***Refer to standard NFPA 70E or equivalent safety standards in corresponding regions for details of the dangers involved and for the safety requirements.***

Guidelines to follow when working on de-energized electrical systems:

- Use proper PPE. Do not wear jewelry and make sure that any conductive items are removed from pockets as these items can fall into equipment and the resulting short circuit can cause shock or burning. Refer to standard NFPA 70E for PPE standards.
- De-energize and lockout/tagout electrical systems prior to working on them. Lockout/Tagout is intended to prevent injury due to unexpected start-up of equipment or the release of stored energy. Please refer to the lockout/tagout section for more information.
- De-energize and lockout/tagout all circuits and devices before removing any protective shields or making any measurements on electrical equipment.
- Follow all applicable regional electrical and safety codes.

Guidelines to follow when working on energized electrical systems:

#### NOTICE

**It is the policy of Cummins Inc. to perform all electrical work in a de-energized state. However, employees or suppliers may be permitted to occasionally perform work on energized electrical equipment only when qualified and authorized to do so and when troubleshooting, or if de-energizing the equipment would create a greater risk or make the task impossible and all other alternatives have been exhausted.**

**NOTICE**

**Exposed energized electrical work is only allowed as per the relevant procedures and must be undertaken by a Cummins authorized person with any appropriate energized work permit for the work to be performed while using proper PPE, tools and equipment.**

In summary:

- Do not tamper with or bypass interlocks unless you are authorized to do so.
- Understand and assess the risks - use proper PPE. Do not wear jewelry and make sure that any conductive items are removed from pockets as these items can fall into equipment and the resulting short circuit can cause shock or burning. Refer to standard NFPA 70E for PPE standards.
- Make sure that an accompanying person who can undertake a rescue is nearby.

### 1.4.1 AC Supply and Isolation

**NOTICE**

**Local electrical codes and regulations (for example BS EN 12601:2010 Reciprocating internal combustion engine driven generating sets. Safety) may require the installation of a disconnect means for the generator set, either on the generator set or where the generator set conductors enter a facility.**

**NOTICE**

**The AC supply must have the correct over current and earth fault protection according to local electrical codes and regulations. This equipment must be earthed (grounded).**

It is the sole responsibility of the customer to provide AC power conductors for connection to load devices and the means to isolate the AC input to the terminal box; these must comply to local electrical codes and regulations. Refer to the wiring diagram supplied with the generator set.

The disconnecting device is not provided as part of the generator set, and Cummins Power Generation accepts no responsibility for providing the means of isolation.

### 1.4.2 Medium Voltage Equipment (601 V to 15 kV)

- Medium voltage acts differently than low voltage. Special equipment and training is required to work on or around medium voltage equipment. Operation and maintenance must be done only by persons trained and experienced to work on such devices. Improper use or procedures will result in severe personal injury or death.
- Do not work on energized equipment. Unauthorized personnel must not be permitted near energized equipment. Due to the nature of medium voltage electrical equipment, induced voltage remains even after the equipment is disconnected from the power source. Plan the time for maintenance with authorized personnel so that the equipment can be de-energized and safely grounded.

## 1.5 Fuel And Fumes Are Flammable

Fire, explosion, and personal injury or death can result from improper practices.

- DO NOT fill fuel tanks while the engine is running, unless the tanks are outside the engine compartment. Fuel contact with hot engine or exhaust is a potential fire hazard.
- DO NOT permit any flame, cigarette, pilot light, spark, arcing equipment, or other ignition source near the generator set or fuel tank.
- Fuel lines must be adequately secured and free of leaks. Fuel connection at the engine should be made with an approved flexible line. Do not use copper piping on flexible lines as copper will become brittle if continuously vibrated or repeatedly bent.
- Be sure all fuel supplies have a positive shutoff valve.
- Be sure the battery area has been well-ventilated prior to servicing near it. Lead-acid batteries emit a highly explosive hydrogen gas that can be ignited by arcing, sparking, smoking, etc.

### 1.5.1 Spillage

Any spillage that occurs during fueling or during oil top-off or oil change must be cleaned up before starting the generator set.

### 1.5.2 Fluid Containment

#### NOTICE

**Where spillage containment is not part of a Cummins supply, it is the responsibility of the installer to provide the necessary containment to prevent contamination of the environment, especially water courses and sources.**

If fluid containment is incorporated into the bedframe, it must be inspected at regular intervals. Any liquid present should be drained out and disposed of in line with local health and safety regulations. Failure to perform this action may result in spillage of liquids which could contaminate the surrounding area.

Any other fluid containment area must also be checked and emptied, as described above.

### 1.5.3 Do Not Operate in Flammable and Explosive Environments

Flammable vapor can cause an engine to overspeed and become difficult to stop, resulting in possible fire, explosion, severe personal injury, and death. Do not operate a generator set where a flammable vapor environment can be created, unless the generator set is equipped with an automatic safety device to block the air intake and stop the engine. The owners and operators of the generator set are solely responsible for operating the generator set safely. Contact your authorized Cummins Power Generation distributor for more information.

## 1.6 Exhaust Gases Are Deadly

- Provide an adequate exhaust system to properly expel discharged gases away from enclosed or sheltered areas and areas where individuals are likely to congregate. Visually and audibly inspect the exhaust daily for leaks per the maintenance schedule. Make sure that exhaust manifolds are secured and not warped. Do not use exhaust gases to heat a compartment.
- Be sure the unit is well ventilated.

### 1.6.1 Exhaust Precautions

#### WARNING

***Hot pipes.***

***Hot exhaust pipes and charge air pipes can cause severe personal injury or death from direct contact, or from fire hazard.***

***Wear appropriate PPE when working on hot equipment and avoid physical contact where possible.***

#### WARNING

***Hot exhaust gases.***

***Can cause burns resulting in severe personal injury.***

***Wear personal protective equipment when working on equipment.***

#### WARNING

***Inhalation of exhaust gases.***

***Breathing exhaust fumes can result in serious personal injury or death.***

***Be sure deadly exhaust gas is piped outside and away from windows, doors, or other inlets to buildings. Do not allow to accumulate in habitable areas***

#### WARNING

***Contaminated insulation.***

***Is a fire risk which can result in severe personal injury and equipment damage.***

***Remove any contaminated insulation and dispose of in accordance with local regulations.***

The exhaust outlet may be sited at the top or bottom of the generator set. Make sure that the exhaust outlet is not obstructed. Personnel using this equipment must be made aware of the exhaust position. Position the exhaust away from flammable materials - in the case of exhaust outlets at the bottom, make sure that vegetation is removed from the vicinity of the exhaust.

The exhaust pipes may have some insulating covers fitted. If these covers become contaminated they must be replaced before the generator set is run.

To minimize the risk of fire, make sure the following steps are observed:

- Make sure that the engine is allowed to cool thoroughly before performing maintenance or operation tasks.
- Clean the exhaust pipe thoroughly.

## 2 Introduction

---

### WARNING

*Hazardous voltage.*

*Can cause severe personal injury or death and equipment damage.*

*Generator electrical output connections must be made by a trained and experienced electrician in accordance with the installation instructions and all applicable codes.*

### WARNING

*Electrical generating equipment.*

*Can cause severe personal injury or death.*

*Generator sets must be installed, certified, and operated by trained and experienced person in accordance with the installation instructions and all applicable codes.*

## 2.1 About This Manual

The purpose of this manual is to provide the users with sound, general information. It is for guidance and assistance with recommendations for correct and safe procedures. Cummins Power Generation (CPG) cannot accept any liability whatsoever for problems arising as a result of following recommendations in this manual.

The information contained within the manual is based on information available at the time of going to print. In line with Cummins Power Generation policy of continuous development and improvement, information may change at any time without notice. The users should therefore make sure that before commencing any work, they have the latest information available. The latest version of this manual is available on QuickServe Online (<https://qsol.cummins.com/info/index.html>).

Users are respectfully advised that, in the interests of good practice and safety, it is their responsibility to employ competent persons to carry out any installation work. Consult your authorized distributor for further installation information. It is essential that the utmost care is taken with the application, installation, and operation of any engine due to their potentially hazardous nature. Careful reference should also be made to other Cummins Power Generation literature. A generator set must be operated and maintained properly if you are to expect safe and reliable operation.

For further assistance, contact your authorized distributor.

### 2.1.1 Additional Installation Manual Information

The purpose of this manual is to provide the Installation Engineer with sound, general information for the installation of the generator set. Refer to the Generator Set Operator Manual for additional information which must also be read before operating the set.

This manual provides installation instructions for the generator set models listed on the front cover. This includes the following information:

- **Mounting Recommendations** - for fastening the generator set to a base and space requirements for normal operation and service.
- **Mechanical and Electrical Connections** - covers most aspects of the generator set installation.

- **Prestart** - checklist of items or procedures needed to prepare the generator set for operation.
- **Installation Checklist** - reference checks upon completion of the installation.

This manual **DOES NOT** provide application information for selecting a generator set or designing the complete installation. If it is necessary to design the various integrated systems (fuel, exhaust, cooling, etc.), additional information is required. Review standard installation practices. For engineering data specific to the generator set, refer to the Specification and Data Sheets. For application information, refer to Application Manual T-030, "Liquid Cooled Generator Sets." To find this manual online:

1. Go to [www.cumminspower.com](http://www.cumminspower.com)
2. Click on "Application Engineering" under heading, Technical Information.
3. Click on "Liquid Cooled Genset Application Manual"

## 2.2 Schedule of Abbreviations

This list is not exhaustive. For example, it does not identify units of measure or acronyms that appear only in parameters, event/fault names, or part/accessory names.

AmpSentry, INSITE, and InPower are trademarks of Cummins Inc. PowerCommand is a registered trademark of Cummins Inc.

ABBR.	DESCRIPTION	ABBR.	DESCRIPTION
AC	Alternating Current	LCT	Low Coolant Temperature
AMP	AMP, Inc., part of Tyco Electronics	LED	Light-emitting Diode
ANSI	American National Standards Institute	MFM	Multifunction Monitor
ASTM	American Society for Testing and Materials (ASTM International)	Mil Std	Military Standard
ATS	Automatic Transfer Switch	NC	Normally Closed
AVR	Automatic Voltage Regulator	NC	Not Connected
AWG	American Wire Gauge	NFPA	National Fire Protection Agency
CAN	Controlled Area Network	NO	Normally Open
CB	Circuit Breaker	NWF	Network Failure
CE	Conformité Européenne	OEM	Original Equipment Manufacturer
CFM	Cubic Feet per Minute	OOR	Out of Range
CGT	Cummins Generator Technologies	OORH / ORH	Out of Range High
CMM	Cubic Meters per Minute	OORL / ORL	Out of Range Low
CT	Current Transformer	PB	Push Button
DC	Direct Current	PCC	PowerCommand® Control
DEF	Diesel Exhaust Fluid	PGI	Power Generation Interface
DPF	Diesel Particulate Filter	PGN	Parameter Group Number
ECM	Engine Control Module	PI	Proportional/Integral
ECS	Engine Control System	PID	Proportional/Integral/Derivative

ABBR.	DESCRIPTION	ABBR.	DESCRIPTION
EMI	Electromagnetic interference	PLC	Programmable Logic Controller
EN	European Standard	PMG	Permanent Magnet Generator
EPS	Engine Protection System	PT	Potential Transformer
E-Stop	Emergency Stop	PTC	Power Transfer Control
FAE	Full Authority Electronic	PWM	Pulse-width Modulation
FMI	Failure Mode Identifier	RFI	Radio Frequency Interference
FSO	Fuel Shutoff	RH	Relative Humidity
Genset	Generator Set	RMS	Root Mean Square
GCP	Generator Control Panel	RTU	Remote Terminal Unit
GND	Ground	SAE	Society of Automotive Engineers
HMI	Human-machine Interface	SCR	Selective Catalytic Reduction
IC	Integrated Circuit	SPN	Suspect Parameter Number
ISO	International Organization for Standardization	SW_B+	Switched B+
LBNG	Lean-burn Natural Gas	UL	Underwriters Laboratories
LCD	Liquid Crystal Display	UPS	Uninterruptible Power Supply

## 2.3 Related Literature

Before any attempt is made to operate the generator set, the Operator should take time to read all of the manuals supplied with the generator set, and to familiarize themselves with Warnings and Operating Procedures.

### CAUTION

***A generator set must be operated and maintained properly if you are to expect safe and reliable operation.***

The relevant publications appropriate to your generator set are also available:

- Operator Manual (A030G173)
- Service Manual (A030G174)
- Engine Service Manual (A030M990)
- *Specification and Data Sheet* (For engineering data specific to the generator set)
- Application Manual T-030, *Liquid Cooled Generator Sets* (For application information)
- Parts Manual (A030F464)

### NOTICE

**Read the warranty statement provided with the genset for US Environmental Protection Agency (EPA) restrictions on servicing specific components.**

Contact your authorized distributor.

## 2.4 After Sales Services

Cummins Power Generation offers a full range of maintenance and warranty services.

### 2.4.1 Maintenance

#### WARNING

**Electrical generating equipment**  
***Incorrect service or parts replacement can result in severe personal injury, death, and/or equipment damage.***  
***Service personnel must be trained and experienced to perform electrical and/or mechanical service.***

For expert generator set service at regular intervals, contact your local distributor. Each local distributor offers a complete maintenance contract package covering all items subject to routine maintenance, including a detailed report on the condition of the generator set. In addition, this can be linked to a 24-hour call-out arrangement, providing year-round assistance if necessary. Specialist engineers are available to maintain optimum performance levels from generator sets. Maintenance tasks should only be undertaken by trained and experienced technicians provided by your authorized distributor.

### 2.4.2 Warranty

For details of the warranty coverage for your generator set, refer to the *Global Commercial Warranty Statement* listed in the Related Literature section.

Extended warranty coverage is also available. In the event of a breakdown, prompt assistance can normally be given by factory trained service technicians with facilities to undertake all minor and many major repairs to equipment on site.

For further warranty details, contact your authorized distributor.

#### NOTICE

**Damage caused by failure to follow the manufacturers recommendations will not be covered by the warranty. Please contact your authorized distributor.**

#### 2.4.2.1 Warranty Limitations

For details of the warranty limitations for your generator set, refer to the warranty statement applicable to the generator set.

### 2.4.3 How to Obtain Service

When the generator set requires servicing, contact your nearest Cummins Power Generation distributor. To contact your local Cummins Power Generation distributor refer to the [Global Addresses](#) section contained within this document. When contacting your distributor, always supply the complete Model, Specification, and Serial Number as shown on the nameplate.

# 3 Specifications

## 3.1 Generator Set Specifications

TABLE 1. SPECIFICATIONS

MODELS	GGPA/GGPB/GGPC
<b>Engine</b> Onan Modified GM V-8	GM 5.0 L
<b>Generator kW Rating</b>	See generator set nameplate for rating information.
<b>Engine Fuel Connection</b> Inlet/Outlet Thread Size	Refer to Generator Outline Drawing
<b>Fuel or a combination of two fuels</b>	Propane (Liquid or Vapor) Natural Gas
<b>Fuel Flow (Inlet Pressure)</b> <b>Minimum:</b> NG/LPG <b>Maximum:</b> NG/LPG Vapor Withdrawal LPG Liquid Withdrawal	7.0 inch H <sub>2</sub> O (1.7 KPA)  13.6 inch H <sub>2</sub> O (3.4 kPa) 312 psi (2,153 kPa)
<b>Exhaust</b> Connection Backpressure (Max. Allowed)	3 inch NPT 20 inch WC (5.0 kPa)
<b>Electrical System</b> Starting Voltage Battery Charing Alternator (Max. Rating)	12 Volts DC 37 A
<b>Cooling System</b> Capacity with Standard Radiator	6.9 Gallons (26.1 L)
<b>Lubricating System</b> Oil Capacity with Filters	5.75 Quarts (5.5 L)
<b>Tune-up Specifications</b> Spark Plug Gap	0.030 inch (0.762 mm)
<b>Battery</b> Ground Required Battery Voltage Group Number CCA (minimum) Cold Soak @ 0° F (-18° C)	Negative 12 Volts DC 31 625

**TABLE 2. FUEL CONSUMPTION (STANDBY/PRIME/60 HZ) AT FULL LOAD**

<b>Model</b>	<b>GGPA</b>	<b>GGPB</b>	<b>GGPC</b>
<b>Standby</b> cfh (m3/hr)			
LPG (Vapor or Liquir)	204 (5.8)	225 (6.4)	270.2 (7.7)
Natural Gas	528 (14.9)	590 (16.7)	646 (18.3)

# 4 System Overview

---

This section provides an overview of the Generator Set.

## 4.1 Generator Set Components

[Figure 1](#) shows a typical generator set installation.

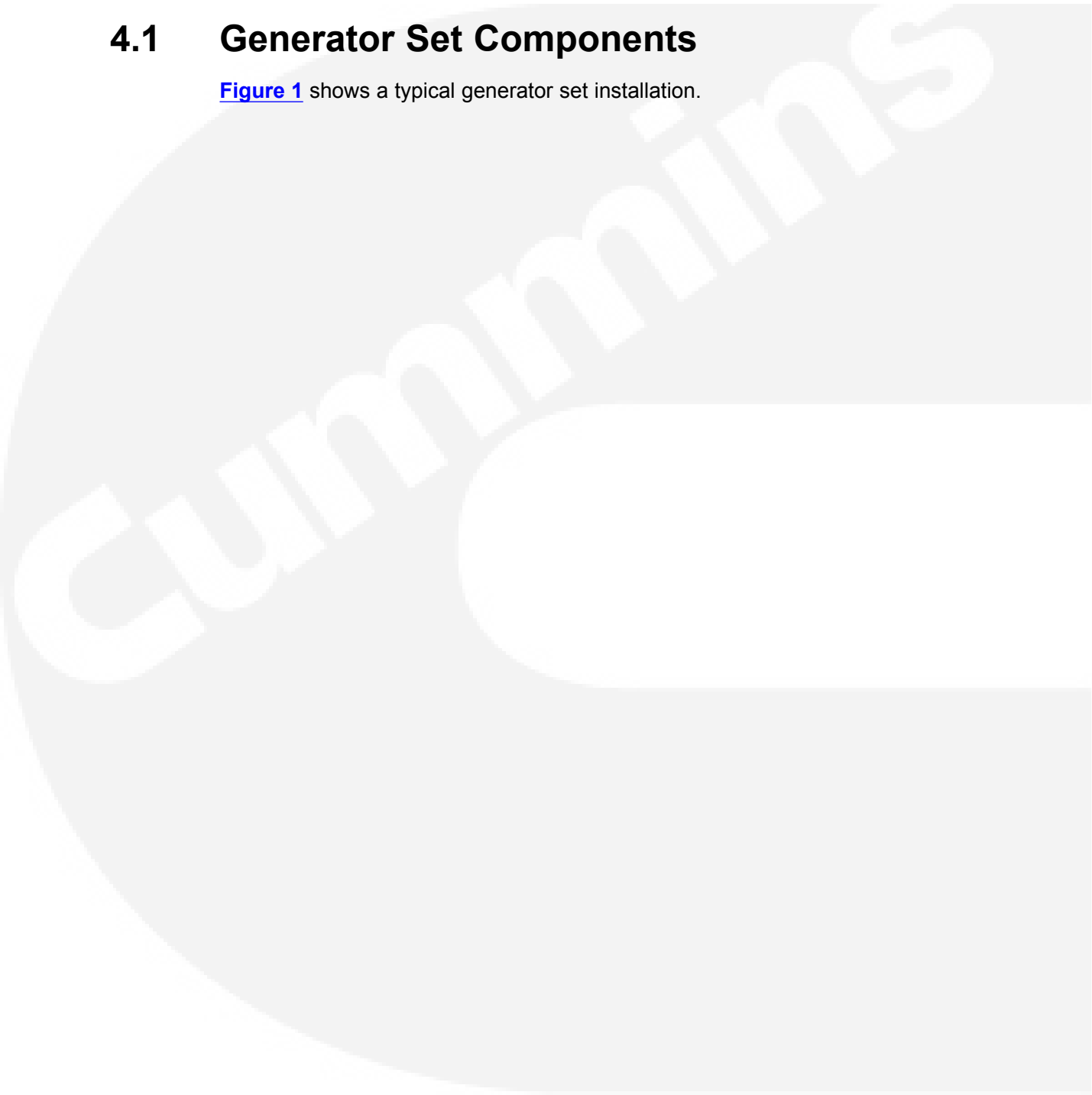

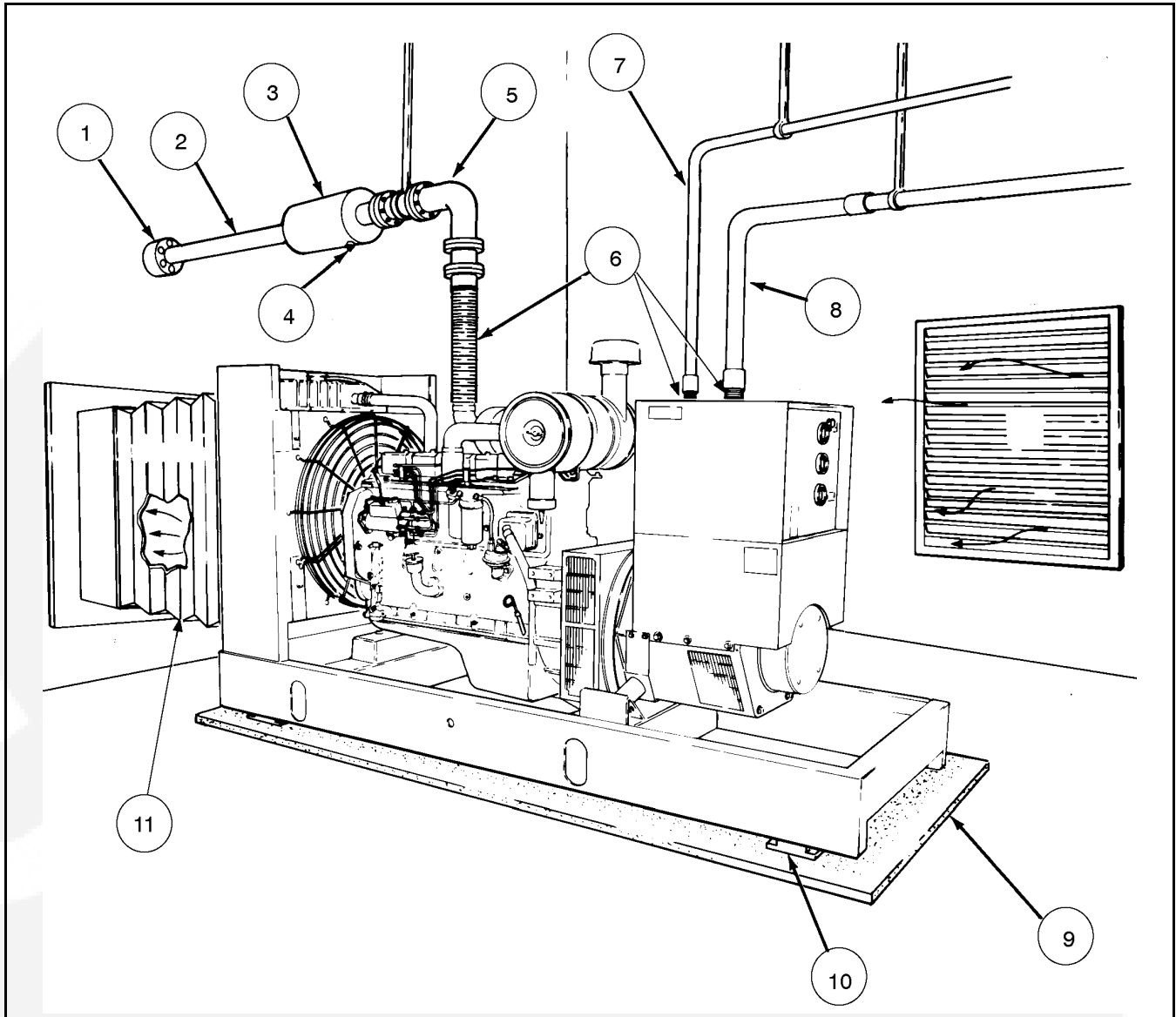

No.	Description	No.	Description
1	Thimble	7	Control Wiring
2	Exhaust Line	8	Power Wiring
3	Muffler	9	Level Concrete Base
4	Condensation Drain Plug	10	Vibration Isolators
5	Sweeping Elbow	11	Flexible Bellows
6	Flexible Sections		

FIGURE 1. TYPICAL GENERATOR SET

## 4.2 Generator Set Rating

For details of your generator set rating refer to the generator set nameplate. Refer to the Operator manual for operation at temperatures or altitudes above those stated on the nameplate.

## 4.3 Engine

For additional engine specific information, refer to the relevant engine manual for your generator set.

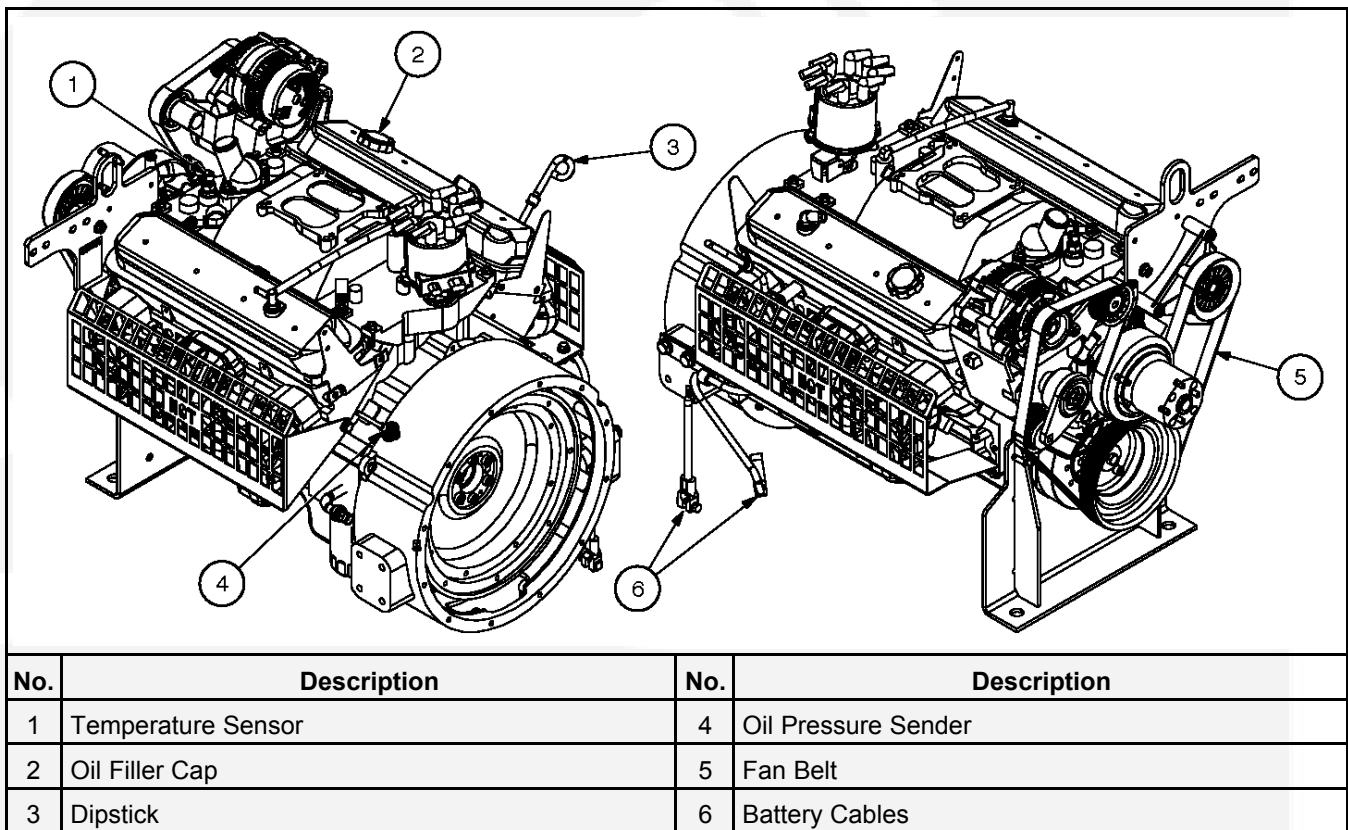

FIGURE 2. TYPICAL ENGINE COMPONENTS

## 4.4 Sensors

Various generator set parameters are measured by sensors, and the resulting signals are processed by the control board.

Engine-mounted sensors monitor a number of different systems, such as:

- Lube Oil Pressure
- Cooling System Temperature

## 4.5 Heaters

### **⚠ CAUTION**

*Energizing heater, or heaters.*

*Operating the heater or heaters when the coolant system has been drained or there is a suspicion that the coolant is frozen, can result in equipment damage.*

*Always make sure the coolant is not frozen and the radiator is filled to the recommended level before energizing the heater, or heaters.*

### 4.5.1 Heater Supply and Isolation

An external power supply is required for the operation of the engine heaters and alternator heaters (if fitted).

#### **NOTICE**

If not already provided, it is the sole responsibility of the customer to provide the power supply and the means to isolate the AC input to the terminal box. Cummins Power Generation accepts no responsibility for providing the means of isolation.

#### **NOTICE**

This disconnecting device is not provided as part of the generator set.

# 5 Installation Overview

---

These installation recommendations apply to typical installations with standard model generator sets. Whenever possible, these recommendations also cover factory designed options or modifications. However, because of the many variables in any installation, it is not possible to provide specific recommendations for every situation. If there are any questions not answered by this manual, contact your nearest authorized distributor for assistance.

## 5.1 Application and Installation

A power system must be carefully planned and correctly installed for proper operation. This involves two essential elements.

- **Application** (as it applies to generator set installations) refers to the design of the complete power system that usually includes power distribution equipment, transfer switches, ventilation equipment, mounting pads, cooling, exhaust, and fuel systems. Each component must be correctly designed so the complete system will function as intended. Application and design is an engineering function generally done by specifying engineers or other trained specialists. Specifying engineers or other trained specialists are responsible for the design of the complete power system and for selecting the materials and products required.
- **Installation** refers to the actual set-up and assembly of the power system. The installers set up and connect the various components of the system as specified in the system design plan. The complexity of the system normally requires the special skills of qualified electricians, plumbers, sheet-metal workers, etc. to complete the various segments of the installation. This is necessary so that all components are assembled using standard methods and practices.

## 5.2 Safety Considerations

The generator set has been carefully designed to provide safe and efficient service when properly installed, maintained, and operated. However, the overall safety and reliability of the complete system is dependent on many factors outside the control of the generator set manufacturer. To avoid possible safety hazards, make all mechanical and electrical connections to the generator set exactly as specified in this manual. All systems external to the generator (fuel, exhaust, electrical, etc.) must comply with all applicable codes. Make certain all required inspections and tests have been completed and all code requirements have been satisfied before certifying the installation is complete and ready for service.

## 5.3 Standby Heating Devices

Cummins Power Generation requires installing standby generator sets (life safety systems) with engine jacket water coolant heaters in order to ensure a 10 second start. Jacket water coolant heaters are also recommended in prime and continuous applications where time and load acceptance is to be minimized.

The jacket water coolant heater provided by Cummins Power Generation is rated to provide the above requirements in ambient temperatures as low as 40 °F (4 °C). Although most Cummins Power Generation generator sets will start in temperatures down to -25 °F (-32 °C) when equipped with engine jacket water coolant heaters, it might take more than 10 seconds to warm the engine before a load can be applied when ambient temperatures are below 40 °F (4 °C).

On generator sets equipped with a graphic display, the **Low Coolant Temperature** message, in conjunction with illumination of the Warning LED, is provided to meet the current requirements. The engine cold sensing logic initiates a warning when the engine jacket water coolant temperature falls below 70 °F (21 °C). In applications where the ambient temperature falls below 40 °F (4 °C), or there exists a high amount of cold airflow, the jacket water coolant heater may not provide the necessary heating. Under these conditions, although the generator set may start, it may not be able to accept load within 10 seconds. When this condition occurs, check the coolant heaters for proper operation. If the coolant heaters are operating properly, other precautions may be necessary to warm the engine before applying a load.

## 5.4 Product Modifications

Agency certified products purchased from Cummins Power Generation comply only with those specific requirements and as noted on company product specification sheets. Subsequent modifications must meet commonly accepted engineering practices and/or local and national codes and standards. Product modifications must be submitted to the local authority having jurisdiction for approval.

# 6 Installing the Generator Set

Generator set installations must be engineered so that the generator set will function properly under the expected load conditions. Use these instructions as a general guide only. Follow the instructions of the consulting engineer when locating or installing any components. The complete installation must comply with all local and state building codes, fire regulations, and other applicable regulations.

Requirements to be considered prior to installation are:

- Level mounting surface
- Adequate cooling air
- Adequate fresh induction air
- Discharge of generator set air
- Non-combustible mounting surface
- Discharge of exhaust gases
- Electrical connections
- Accessibility for operation and servicing
- Noise levels
- Vibration isolation

### NOTICE

*Depending on your location and intended use, ensure that international, national or local laws and regulations regarding Air Quality Emissions have been observed and complied with. Be sure to consult local pollution control or air quality authorities before completing your construction plans.*

## 6.1 Location

### ⚠ WARNING

*Incorrect installation, service or parts.  
Incorrect installation, service or parts replacement can result in severe personal injury, death, and/or equipment damage.  
Service personnel must be trained and experienced to perform electrical and mechanical component installation.*

### NOTICE

**Depending on your location and intended use, additional laws and regulations may require for you to obtain an air quality emissions permit before beginning installation of your generator set. Be sure to consult local pollution control or air quality authorities before completing your construction plans.**

Generator set location is decided mainly by related systems such as ventilation, wiring, fuel, and exhaust. The set should be located as near as possible to the main power service entrance. Exhaust gases must not be able to enter or accumulate around inhabited areas.

Provide a location away from extreme ambient temperatures and protect the generator set from adverse weather conditions.

## 6.2 Mounting

Generator sets are mounted on a steel skid that provides proper support. The engine-generator assembly is isolated from the skid frame by rubber mounts that provide adequate vibration isolation for normal installations. Where required by building codes or special isolation needs, generator sets may be mounted on rubber pads or mechanical spring isolators.

### NOTICE

**The use of unapproved isolators may result in harmful resonances and may void the generator set warranty.**

Mount the generator set on a substantial and level base such as a concrete pad. A non-combustible material must be used for the pad.

Use 16 mm ( $\frac{5}{8}$  inch) or anchored mounting bolts to secure the generator bedframe to the base. Secure the generator bedframe to the skid using flat washer and hexagonal nut for each bolt (see [Figure 3](#)). The 38 mm x 152 mm ( $1\frac{1}{2}$  x 6 inch) pipe inserted over the mounting bolts allows minor adjustment of the bolts to align them to the holes in the bedframe.

The fixing centers for the mounting bolts can be found on the generator set *Outline Drawing* referenced in the *Data Sheet*.

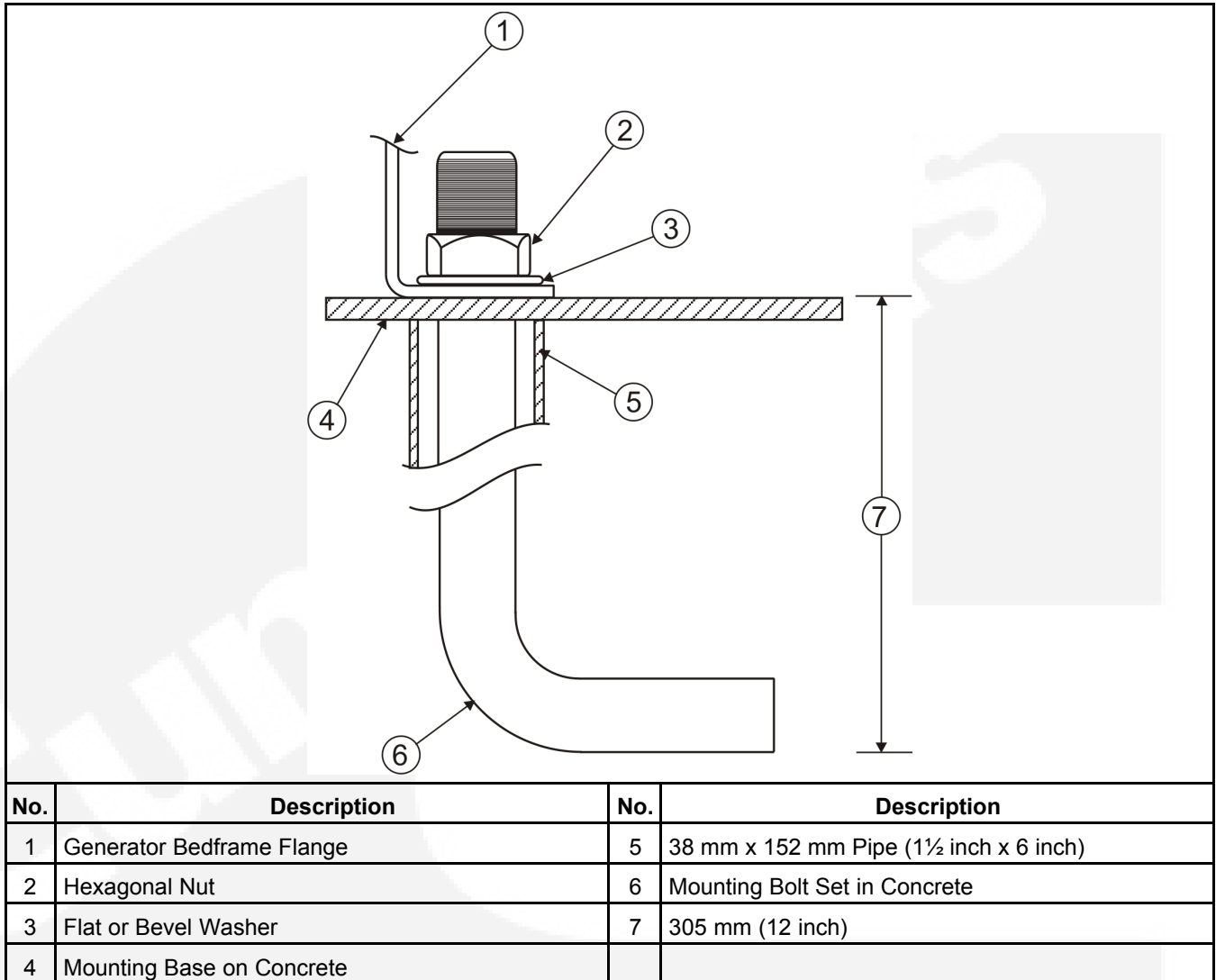

**FIGURE 3. BOLT DIAGRAM**

### 6.3 Access to Set

Generally, at least 1 meter (3.3 feet) of clearance should be provided on all sides of the generator set for maintenance and service access. (Increase clearance by width of door if optional housing is used.) A raised foundation or slab of 152 mm (6 inches) or more above floor level will make servicing easier. Lighting should be adequate for operation, maintenance and service operations and should be connected on the load side of the transfer switch so that it is available at all times.

### 6.4 Vibration Isolator Installation

**NOTICE**

**Ensure that the equipment is stable before installation of the vibration isolator.**

**NOTICE**

1. Place the vibration isolator (FSR Mounting - Free Standing Restrain) under the support point of the equipment, ensure that the load is uniformly distributed over the top plate of the vibration isolator as shown in Figure A & B see [Figure 4](#).
2. Adjust the FSR Mounting.

**NOTICE**

The FSR Mounting shown is pre-assembled with a suitable spacer (6mm). Do not make any adjustment before installation. Adjustment of the FSR Mounting should be done when the equipment is at its operating weight. (Refer to Figure A of [Figure 4](#).)

- a. With the 6 mm spacer in position as shown, tighten the positioning nut.
- b. Turn, the adjusting bolt of the spring counter-clockwise to load the spring. Load all the FSR at the same time to ensure that the total load is uniformly spread onto all the FSR mounts.
- c. Continue the previous step until the spring load equal to the load of the equipment.
- d. When equilibrium point is reached, the 6 mm spacer can be removed from the FSR mount. (Refer to Figure B of [Figure 4](#).)

**NOTICE**

Bolting the equipment to the floor is optional, the vibration isolators (FS - Free Standing, FSR - Free Standing Restrain, FSB - Free Standing Bolted) have acoustical non-slip pads which prevent excessive movements.

**⚠ CAUTION**

*When bolting is required, direct metal contact between the bolts must be avoided. This will prevent transmission or acoustical frequency.*

**⚠ CAUTION**

*For safety reason, it is recommended to lift up the equipment while positioning the vibration isolators.*

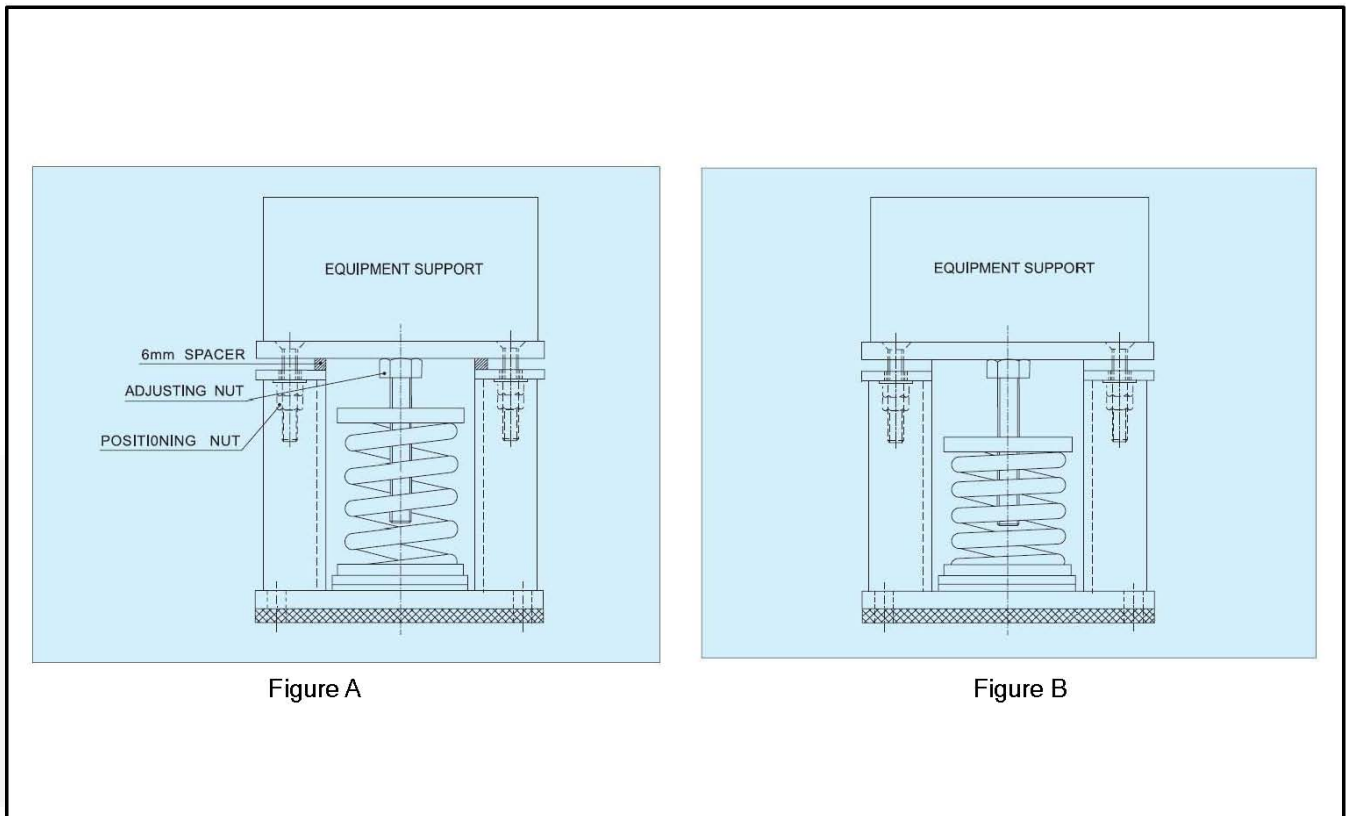

**FIGURE 4. VIBRATION ISOLATORS**

This page is intentionally blank.

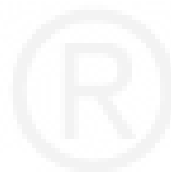

# 7 Mechanical Connections

---

The generator set mechanical system installation includes connecting the fuel, exhaust, ventilation and cooling systems. Before starting any type of fuel installation, all pertinent state and local codes must be complied with and the installation must be inspected before the unit is put in service.

## 7.1 Overview

The generator set mechanical system installation includes connecting the fuel, exhaust, ventilation and cooling systems. Before starting any type of fuel installation, all pertinent state and local codes must be complied with and the installation must be inspected before the unit is put in service.

### NOTICE

**All pipe threaded fuel system fittings, including container fittings, must be assembled using a pipe joint sealing compound designed for use with LPG/NG.**

## 7.2 Fuel System

Gensets can be equipped to operate on:

- LPG (vapor or liquid withdrawal)
- NG (natural gas) or
- Combination (NG/LPG)

In all fuel system installations, cleanliness is of the utmost importance. Make every effort to prevent entrance of moisture, dirt or contaminants of any kind. Clean all fuel system components before installing

## 7.3 Fuel Lines Routing

A flexible fuel hose(s) or section of flexible fuel hose(s) must be used between the engine's fuel system and fuel supply line to protect the fuel system from damage caused by vibration, expansion and contraction.

### ⚠ WARNING

***Fuel leaks create fire and explosion hazards which can result in severe personal injury or death. Always use flexible tubing between engine and fuel supply to avoid line failure and leaks due to vibration. The fuel system must meet applicable codes.***

Installation of the fuel hose must be done according to all applicable codes and standards, and installation recommendations provided by the manufacturer. The flexible hose used must be approved by the hose manufacture for use with the genset fuel type and product application.

Support fuel lines to restrain movement and prevent chaffing or contact with sharp edges, electrical wiring and hot exhaust parts.

**⚠ WARNING**

***Sparks and hot surfaces can ignite fuel, leading to severe personal injury or death. Do not route fuel lines near electrical wiring or hot exhaust parts.***

Fuel lines must be routed and secured to maintain a 2 inch (51 mm) minimum clearance from electrical wiring and hot exhaust parts.

## 7.4 Natural Gas/LPG Vapor/LPG Liquid Fuel System

**⚠ WARNING**

***Gaseous fuels are flammable and explosive and can cause severe personal injury or death. Do not smoke if you smell gas or are near fuel tanks or fuel-burning equipment or are in an area sharing ventilation with such equipment. Keep flames, sparks, pilot lights, electrical arcs and arc-producing equipment and all other sources of ignition well away from genset and areas sharing ventilation. Keep a type ABC fire extinguisher handy.***

***NFPA Standard No. 58 requires all persons handling and operating LPG to be trained in proper handling and operating procedures.***

Gaseous-fuel supply system design, materials, components, fabrication, assembly, installation, testing, inspection, operation and maintenance must comply with the applicable codes. See NFPA Standards No. 37, No. 54 and No. 58.

Most codes require both manual and electric (battery-powered) shutoff valves ahead of the flexible fuel hose(s). The manual valve should be of the indicating type. The electric valve should be wired so that the valve is closed when the genset is off.

Install a dry-type fuel filter ahead of the service pressure regulator to protect the sensitive pressure regulating components and orifices downstream from rust, scale and other solid substances carried along in the gas stream.

See [Specifications](#) section for natural gas/LPG fuel inlet size. The recommendations in Application Manual T-030, should be followed in regard to fuel supply system pipe sizes, manual shutoff valves, fuel filters and gas pressure regulators.

## 7.5 Fuel Pressure

**⚠ WARNING**

***High gas supply pressure can cause gas leaks which can lead to fire and severe personal injury or death. Gas supply pressure must be adjusted to Specifications by qualified personnel.***

The gas pressure regulators in each line provide constant gas pressure at the gas mixer under varying load conditions. There are pressure test ports on both sides of the regulator for measuring supply and regulated fuel pressures (NG or LPG systems). When measuring supply pressure, the most accurate reading would be on the input side of the solenoid valve.

- **Mixerside:** The NG gas pressure should be approximately negative 0.4" WC (0.1 kPa) and no load and negative 1.5" WC (0.48 kPa) at full load. The LP gas pressure should be approximately negative 0.4" WC (0.1 kPa) and no load and negative 1.5" WC (0.48 kPa) at full load.
- **Supply side:** The minimum pressure refers to supply pressure under rated load (maximum gas flow).

For LPG (vapor withdrawal) and NG, the maximum permissible fuel supply pressure is 13.6 inches WC (3.4 kPa) and the recommended minimum is 7 inches WC (1.7 kPa).

For LPG (liquid withdrawal), the maximum permissible fuel supply pressure is 312 psi (2,153 kPa) under any operating condition.

**⚠ WARNING**

***Gaseous fuel leaks into an inadequately ventilated space can lead to explosive accumulations of gas. Natural gas rises when released into the air and can accumulate under overhanging hoods and inside housings and buildings. LPG sinks when released into the air and can accumulate inside housings, basements and other below-grade spaces. Precautions must be taken to prevent gas leaks and the accumulation of gaseous fuel in the event of a leak.***

## 7.6 Check Gas Leaks and Correct

All fuel-system connections, including the container with associated valves and fittings, must be tested for leaks with a soap and water solution or equivalent, while the system is under pressure. LP gas pressure should not be less than 90 psi (621 kPa) at the inlet of the primary regulator for this test.

## 7.7 Exhaust System

Pipe exhaust gases to the outside of any enclosure. Locate the exhaust outlets away from any air inlets to avoid gases re-entering the enclosure. Exhaust installations are subject to various detrimental conditions such as extreme heat, infrequent operation and light loads. Regularly inspect the exhaust system both visually and audibly to see that the entire system remains fume tight and safe for operation.

**⚠ WARNING**

***Inhalation of exhaust gasses can result in severe personal injury or death. Use extreme care during installation to provide a tight exhaust system. Terminate exhaust pipes away from enclosed or sheltered areas, windows, doors and vents.***

For indoor installation, the exhaust system should use sealed joint type fittings where possible to provide a tight exhaust system. Use of slip type fittings (secured with a clamp) may allow leakage of exhaust gases into the building if not fitted correctly fitted. Check there are no exhaust leaks.

**⚠ WARNING**

***Inhalation of exhaust gasses can result in severe personal injury or death. Use extreme care during installation to provide a tight exhaust system.***

Use an approved thimble (see [Figure 5](#)) where exhaust pipes pass through wall or partitions. Insulated wall/roof thimbles are used where exhaust pipes pass through a combustible roof or wall. This includes structures, such as wood framing or insulated steel decking, etc. Uninsulated wall/roof thimbles are used where exhaust pipes pass through a non-combustible wall or roof, such as concrete. Where applicable, refer to NFPA 37, Section 6-3, *Stationary Combustion Engines and Gas Turbines* for accepted design practices. Build according to the code requirements in effect at the installation site.

**⚠ WARNING**

***Hot exhaust pipes can start a fire and cause severe injury or death if improperly routed through walls. Use an approved thimble where exhaust pipes pass through wall or partitions.***

**⚠ WARNING**

***Inhalation of exhaust gases can result in severe personal injury or death. do not use exhaust heat to warm a room, compartment or storage area.***

Rain caps are available for the discharge end of vertical exhaust pipes. The rain cap clamps onto the end of the pipe and opens due to exhaust discharge force from the generator set. When the generator set is stopped, the rain cap automatically closes, protecting the exhaust system from rain, snow, etc.

Use a section of flexible exhaust pipe between the engine and remainder of exhaust system. Support the exhaust system to prevent weight from being applied to engine exhaust outlet connection.

**⚠ CAUTION**

***Weight applied to the engine manifold can result in turbocharger damage. Support the silencer and exhaust piping so no weight or stress is applied to the engine exhaust elbow.***

The exhaust system design should meet local code requirements.

**NOTICE**

***Liability for injury, death, damage, and warranty expense due to use of unapproved silencers or modifications to the exhaust system becomes the responsibility of the person installing the unapproved silencer or performing the modification. Contact your authorized distributor for approved exhaust system parts.***

Avoid sharp bends by using sweeping, long radius elbows and provide adequate support for the silencer and tailpipe. Pitch a horizontal run of exhaust pipe downward (away from engine) to allow any moisture condensation to drain away from the engine. If an exhaust pipe must be turned upward, install a condensation trap at the point where the rise begins see [Figure 6](#).

Shield or insulate exhaust lines if there is danger of personal contact. Allow at least 305 mm (12 inches) of clearance if the pipes pass close to a combustible wall or partition. Before installing insulation on exhaust system components, check the exhaust system for leaks while operating the generator set under full load and correct all leaks.

If the exhaust line must be pitched upward, construct a condensation trap at the point of rise. Avoid sharp bends and drain the trap periodically.

**⚠ WARNING**

*Exhaust pipes are very hot and they can cause severe personal injury or death from direct contact or from fire hazard. Shield or insulate exhaust pipes if there is danger of personal contact or when routed through walls or near other combustible materials.*

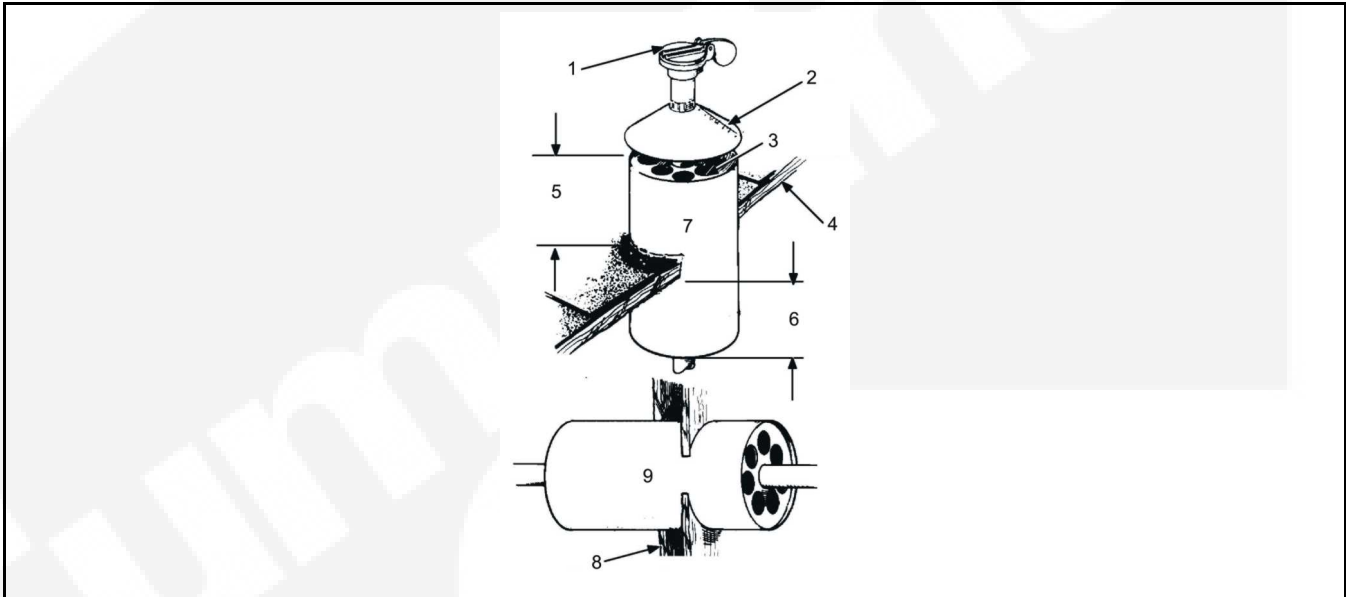

1	Rain Cap	6	230mm (9 inches)
2	Drip Cap	7	Vertical Alignment
3	Holes in End of Inner sleeve	8	Wall or Partition
4	Roof	9	Horizontal Alignment
5	230mm (9 inches)		

**FIGURE 5. MOUNTING EXHAUST THIMBLE**

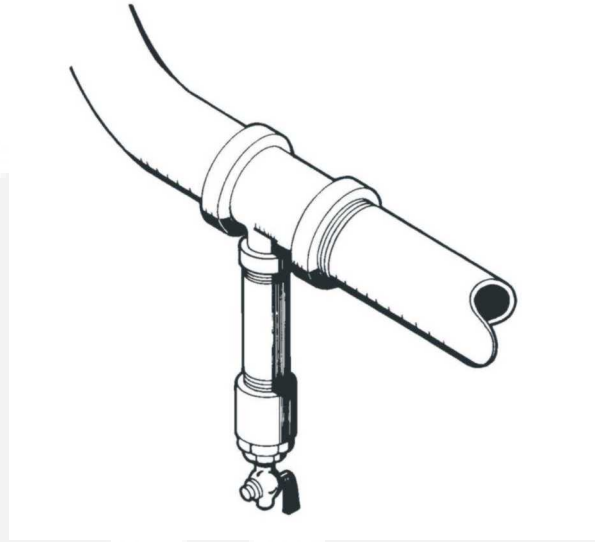

FIGURE 6. CONDENSATION TRAP

## 7.8 Ventilation and Cooling

### ⚠ WARNING

**Carbon monoxide gas.**

**Engine or radiator cooling air may carry deadly carbon monoxide gas which can cause asphyxiation and death.**

**All engine or radiator cooling air must be discharged to the out-of-doors. Do not use it for heating a room or compartment.**

Generator sets create considerable heat that must be removed by proper ventilation.

Generator sets in factory-mounted housings for outdoor installation are designed for proper cooling and ventilation.

Indoor installations require careful design with respect to cooling and ventilation. In an indoor installation, all radiator cooling air must be discharged to the out-of-doors. Duct adapter kits are available.

Outdoor installations normally rely on natural air circulation but indoor installations need properly sized and positioned vents for required airflow.

## 7.9 Vents and Ducts

For indoor installations, locate vents so incoming air passes through the immediate area of the installation before exhausting. Install the air outlet higher than the air inlet to allow for convection air movement.

Size the vents and ducts so they are large enough to allow the required flow rate of air.

### NOTICE

**The "free area" of ducts must be as large as the exposed area of the radiator. Refer to the generator set Specification Sheet for the airflow requirements and allowed airflow restriction.**

Wind will restrict free airflow if it blows directly into the air outlet vent. Locate the outlet vent so the effects of wind are eliminated, or if outlet vent cannot be located as mentioned, install a wind barrier, see [Figure 7](#).

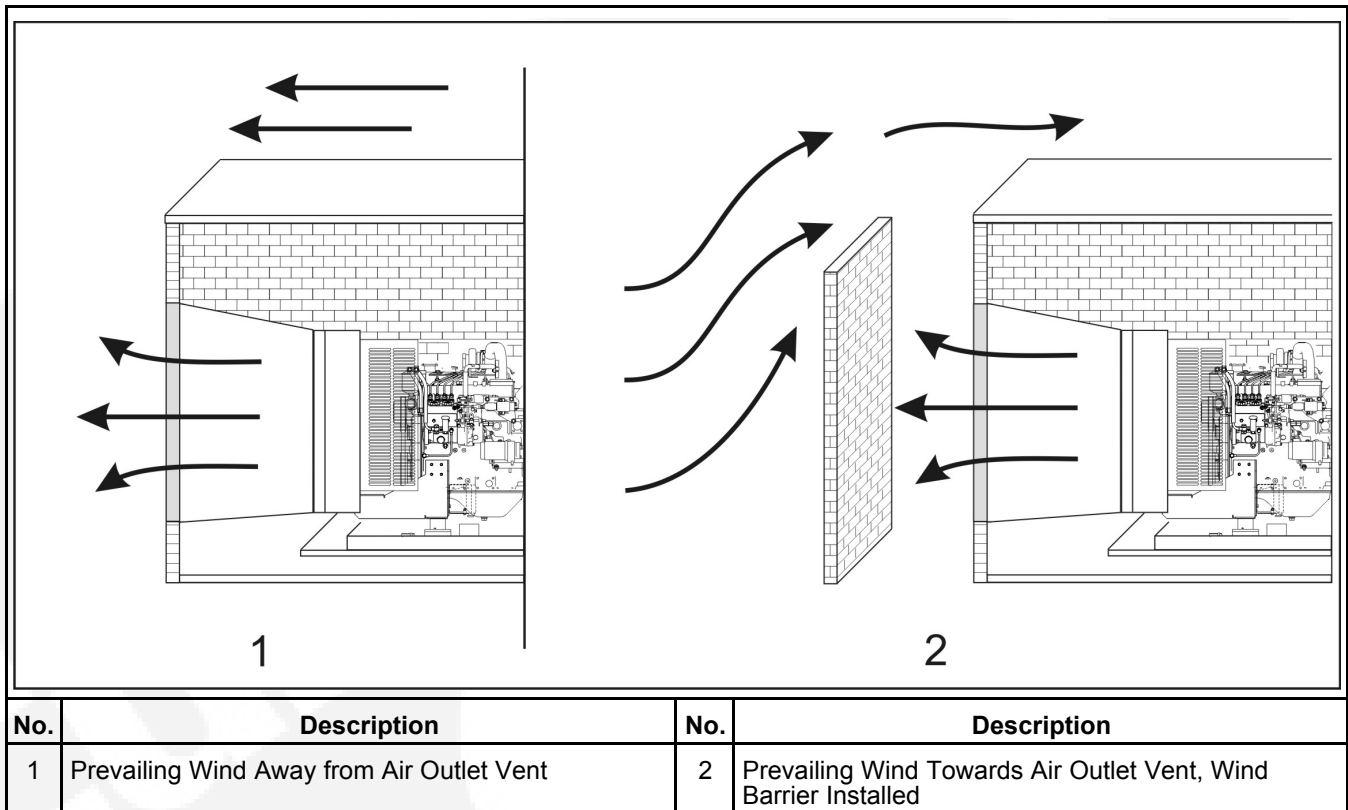

**FIGURE 7. WIND BARRIER**

## 7.10 Dampers

Dampers or louvers protect the generator set and equipment room from the outside environment. Their operation of opening and closing should be controlled by operation of the generator set.

In cold climates, the radiator exhaust air can be recirculated to modulate the ambient air temperature in the generator set room. This will help the generator set warm up faster, and help to keep fuel temperatures higher than the cloud point of the fuel. If recirculation dampers are used, they should be designed to 'fail closed', with the main exhaust dampers open, so that the generator set can continue to operate when required. Designers should be aware that the generator set room operating temperature will be very close to the outdoor temperature, and either not route water piping through the generator set room, or protect it from freezing.

## 7.11 Radiator Set Requirements

Louvers and screens over air inlet and outlet openings restrict air flow and vary widely in performance.

A louver assembly with narrow vanes, for example, tends to be more restrictive than one with wide vanes. The effective open area specified by the louver or screen manufacturer should be used.

Radiator set cooling air is drawn past the control end of the set by a pusher fan that blows air through the radiator. Locate the air inlet to the rear of the set. Make the inlet vent opening  $1\frac{1}{2}$  inches times larger than the radiator area.

Locate the cooling air outlet directly in front of the radiator and as close as possible. The outlet opening must be at least as large as the radiator area. Length and shape of the air outlet duct should offer minimum restriction to airflow.

A flexible duct connector must be provided at the radiator to prevent exhaust air recirculation around the radiator, to take up generator set movement and vibration, and prevent transmission of noise. Attach a canvas or sheet metal duct to the air outlet opening using screws and nuts so that the duct can be removed for maintenance purposes. Before installing the duct, remove the radiator core guard.

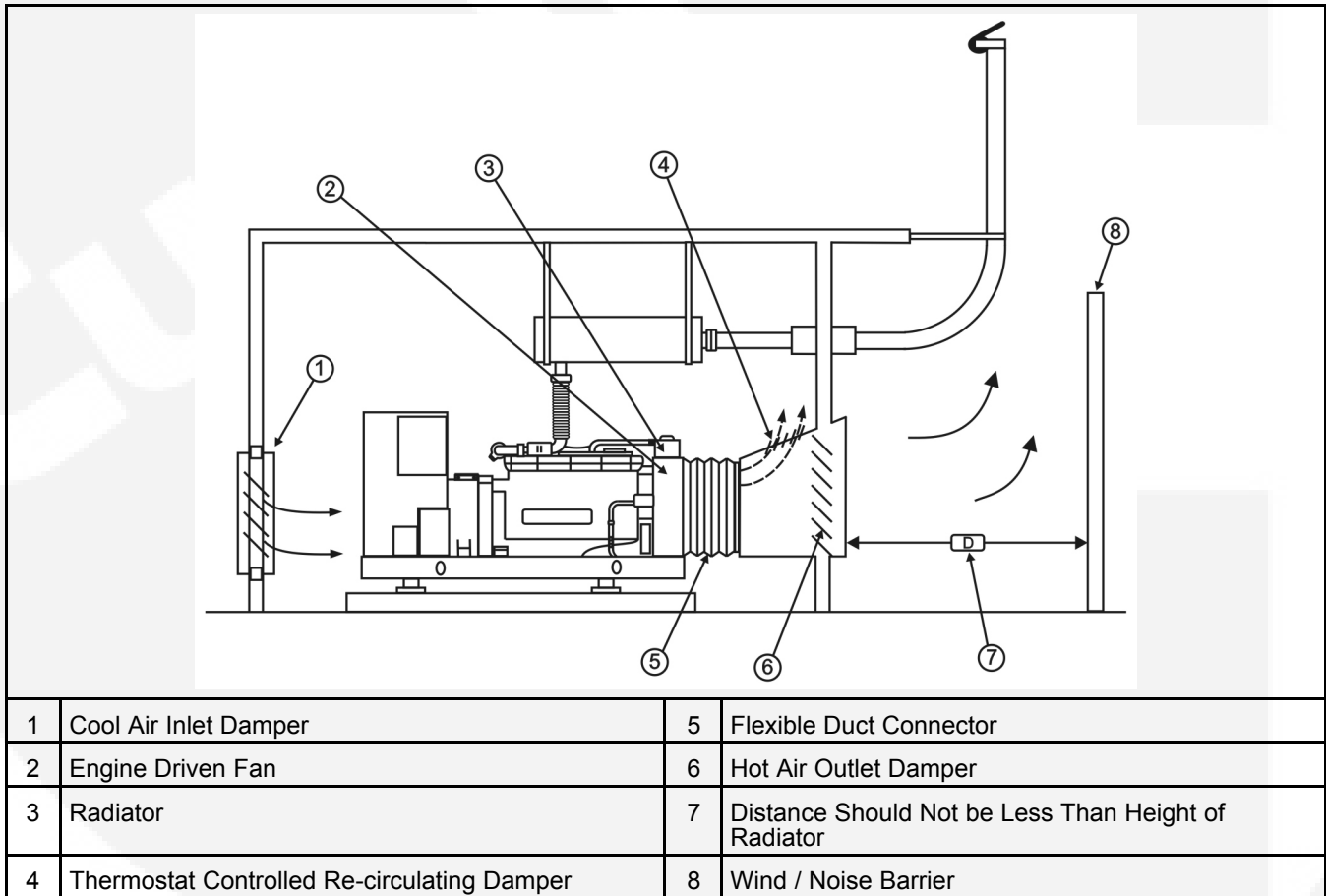

**FIGURE 8. TYPICAL RADIATOR SET INSTALLATION**

# 8 DC Control Wiring

---

The generator set control box contains connection points for remote control and monitor options.

**⚠ CAUTION**

*Stranded copper wire must be used for all customer connections to the control panel. Solid copper wire may break due to the generator set vibration.*

Use flexible conduit for all wiring connections to the generator set.

**⚠ WARNING**

*Hazardous voltage! Touching uninsulated high voltage parts inside the control box can result in severe personal injury or death. Make sure all power is off before performing control wire installation.*

**⚠ WARNING**

*To prevent accidental electrocution stand on a clean dry wooden platform or clean rubber insulating mat, make sure your clothing and shoes are dry, remove jewelry and use tools with insulated handles.*

Route the control wiring through the bottom of the control housing, keep DC wiring away from high voltage AC wiring.

Use cable ties to keep control wiring away from sharp edges and AC power cables within the control housing.

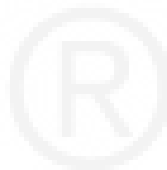

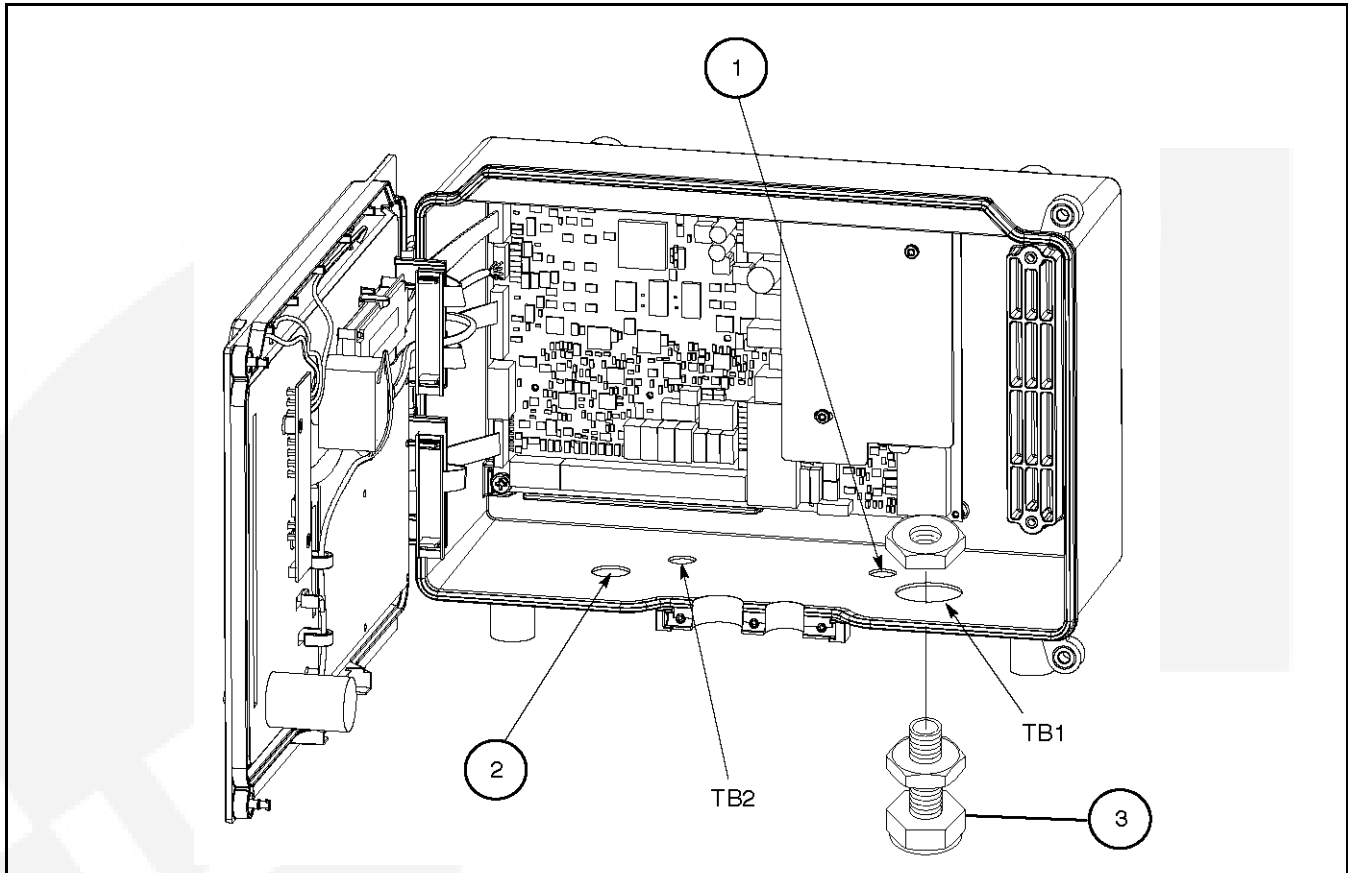

NO	DESCRIPTION
1	Network Communication Module
2	Control Relays (K10, K11, K12) & control Box Heater
3	Strain-Relief Connector

FIGURE 9. SUGGESTED CUSTOMER WIRE ROUTING

## 8.1 PCCnet devices Belden cable

**NOTICE**

When using any PCCNet device on a generator set control application, the wiring used to connect ALL devices in the network must be Belden 9729 Two Pair, Stranded, Shielded Twisted Pair Cable (24 AWG).

## 8.2 TB1 Remote Monitor / Control Connections

Customer monitor/control connections are attached to terminal block TB1. Optional equipment, such as sensing devices used to monitor generator set operation, remote start/stop switches, etc. are also attached to TB1.

Available options will vary between controller models.

## 8.3 PCC 2100 TB1 Customer Connections

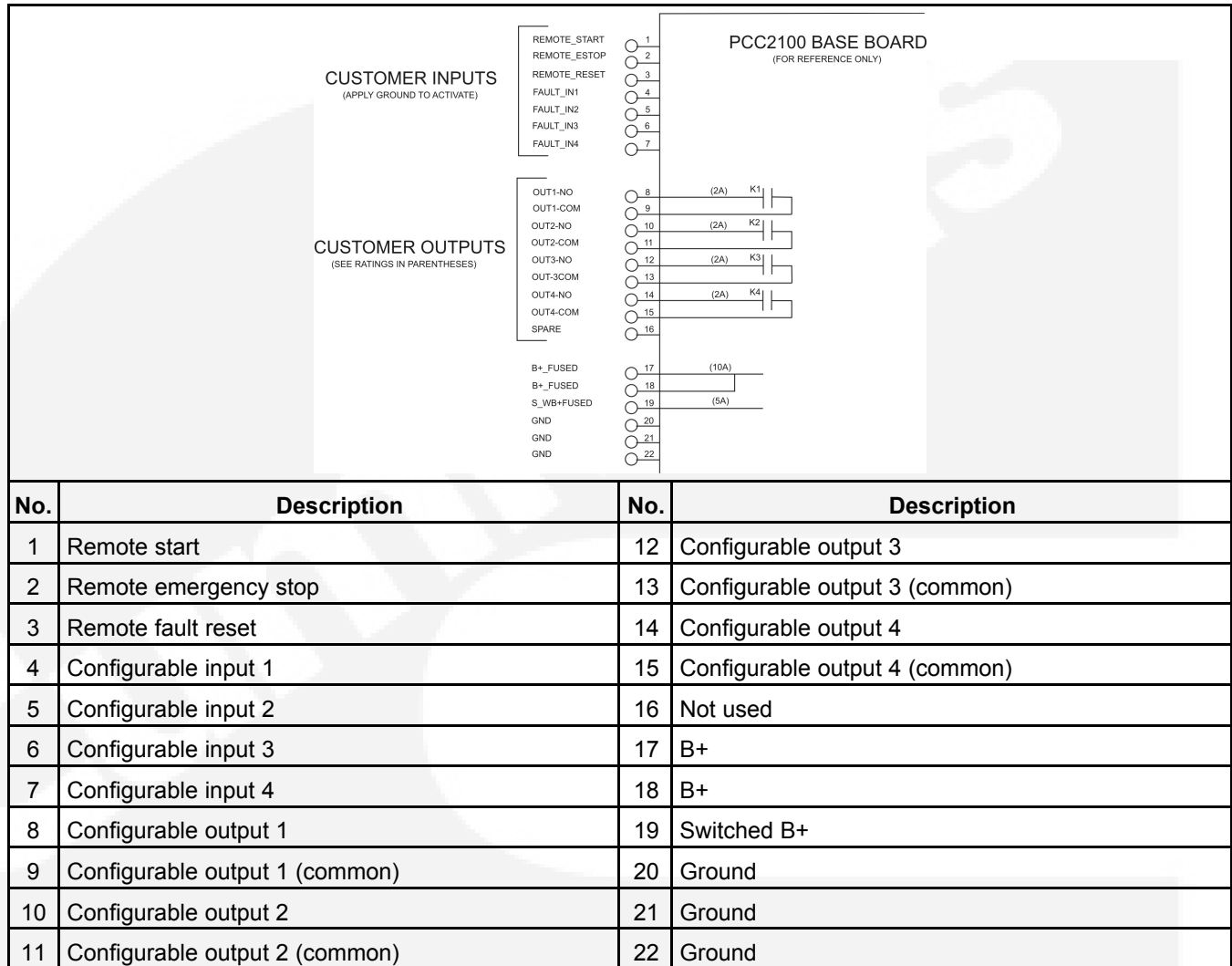

FIGURE 10. PCC 2100 TB1 CUSTOMER CONNECTIONS

## 8.4 TB1 Customer Inputs

**Remote Start:** When the control is in Auto/Remote mode, grounding this input initiates the engine cranking and start sequence. This circuit must be opened to permit resetting a shutdown condition with the Reset input. (The remote stop is actually the removal of the remote start signal to the control.)

**Remote Emergency Stop:** Opening this input causes an immediate shutdown. Emergency stop must be reset at the front panel.

**Customer Fault Inputs 1 through 4:** Grounding any one of these inputs activates the corresponding warning or shutdown sequence.

**NOTICE**

**All four customer inputs may not be available. Customer inputs can be prewired from the factory for genset optional/standard features.**

External sensing equipment must be connected to the designated digital input.

The nature of the fault is an optional customer selection. Example inputs: Low Coolant Level, Low Fuel Pressure, Low Fuel Day Tank, Water In Fuel, Ground Fault, Low Starting Hydraulic Pressure, Low Starting Air Pressure, etc.

Each of the two fault functions can be programmed as follows:

**Status, Warning or Shutdown. Default = Warning.**

**NOTICE**

**The InPower Service Tool or access to the Setup Submenus is required to modify the customer fault inputs. Contact your authorized distributor for assistance.**

Each of the four fault functions can be programmed (using InPower), as follows:

- Enable/disable input. Default setting:  
Enable 1 through 4
- Status, Warning or Shutdown. Default setting:  
1 - None  
2 through 4 - Warning
- Active closed or open. Default setting:  
Closed [ground] 1 through 4
- Change display name using up to 19 characters. Default setting:  
1 - Customer Fault 1  
2 - Ground Fault  
3 - Low Fuel  
4 - Rupture Basin Fault

## 8.5 TB1 Customer Outputs

**Customer Outputs 1 through 4:** One set of normally open (NO) contacts, rated for 2 amps at 30 VDC for each of the four output signals. The relays can be used to control small devices and indicator lamps.

The nature of the customer output signal (contacts closed) is an optional customer selection. Example outputs: Genset running, common warning, common fault, load shed, ready to load, etc.

Each relay can be independently programmed (using InPower) to energize as follows.

- Enable/disable output. Default setting:  
Enable 1 through 4
- Status, Warning or Shutdown. Default setting:

- 1 - Common warning
- 2 - Common shutdown
- 3 - Not in Auto
- 4 - Ready to Load

The customer outputs can also be connected to three control relays (optional) to operate larger equipment, such as, fans, pumps and motorized air dampers. Refer to Control Relays for additional information.

**B+:** This is a fused 10 amp, 12/24 volt output. (Fuse F1 is located on Base board.) Two terminals (TB1-17 and -18) are connected to this 10 amp circuit.

**Switched B+:** This is a fused 5 amp, 12/24 volt switched output. This output is activated when the control receives a run command. (Fuse F2 is located on Base board.)

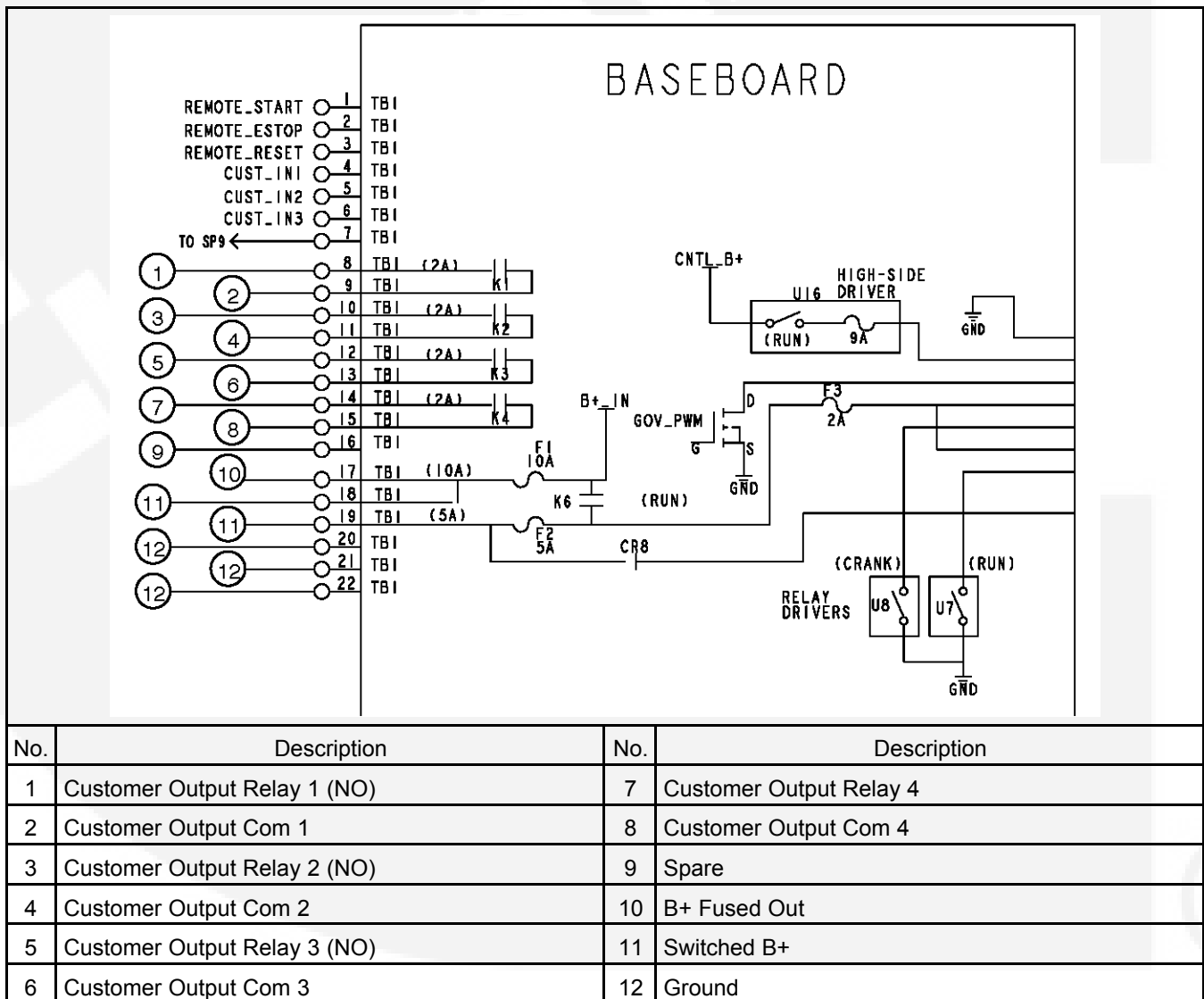

FIGURE 11. SUGGESTED CUSTOMER WIRE ROUTING

## 8.6 Switched B+

Switched B+ is fused at 5 Amps. Wiring is the same as the Relay Connection description.

## 8.7 Run Relays (K10, K11, K12)

**⚠ CAUTION**

*Damage to the Base board can occur if the voltage suppressors (Figures 5-2 and 5-3) are not installed across relay coils (A1/A2) of control relays K11, K12 and K13 before connecting genset battery cables.*

The three optional control relays are rail mounted inside the control panel housing. Each relay is a 4-pole relay with 2 poles normally open and two poles normally closed.

These relays are used to control auxiliary equipment, such as fans, pumps and motorized air dampers. Energizing of the relays is user definable.

The contacts are rated at 10 amps at 600 VAC.

Refer to Customer Connections diagram.

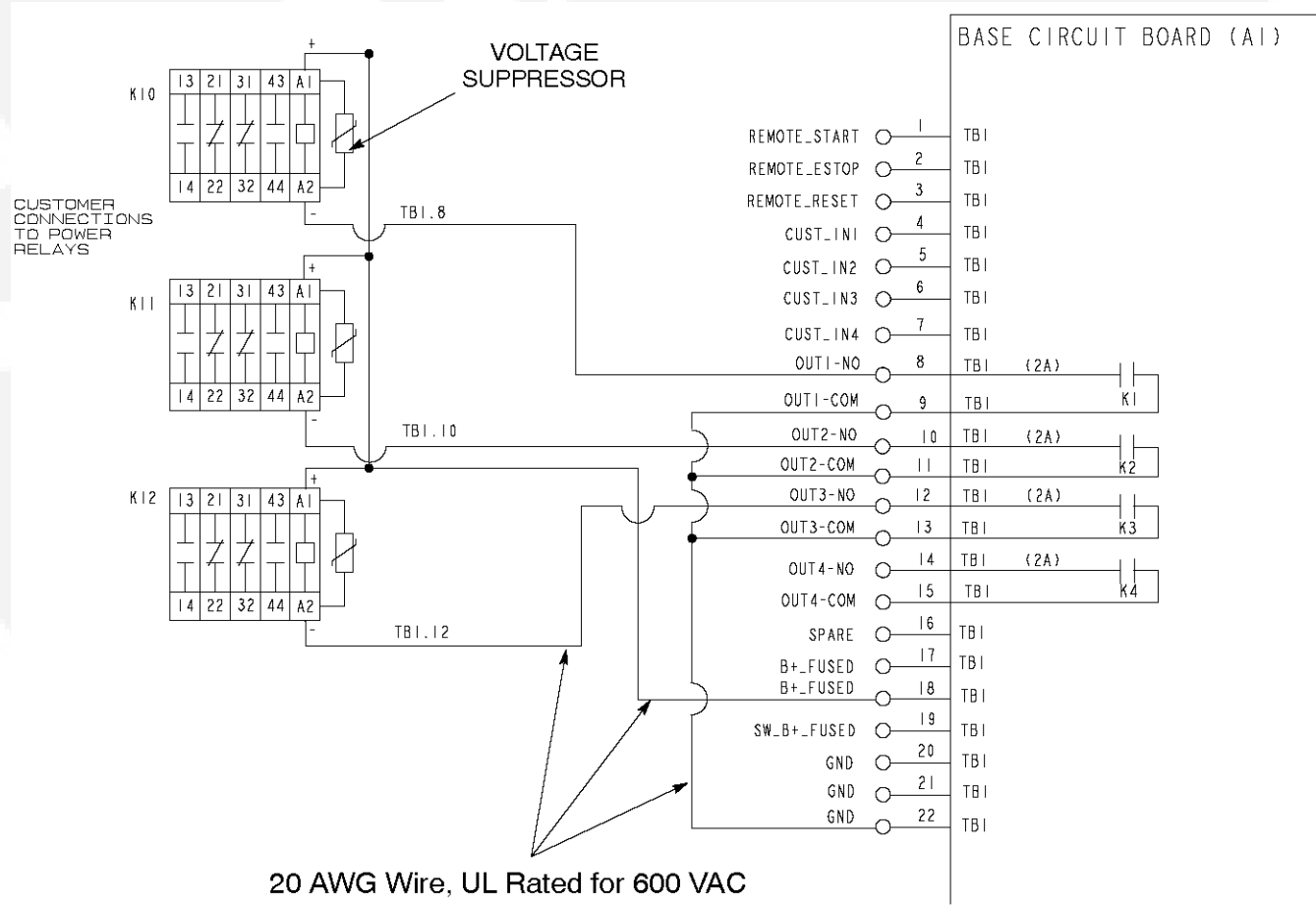

**FIGURE 12. OPTIONAL CONTROL RELAYS (K10, K11, K12)**

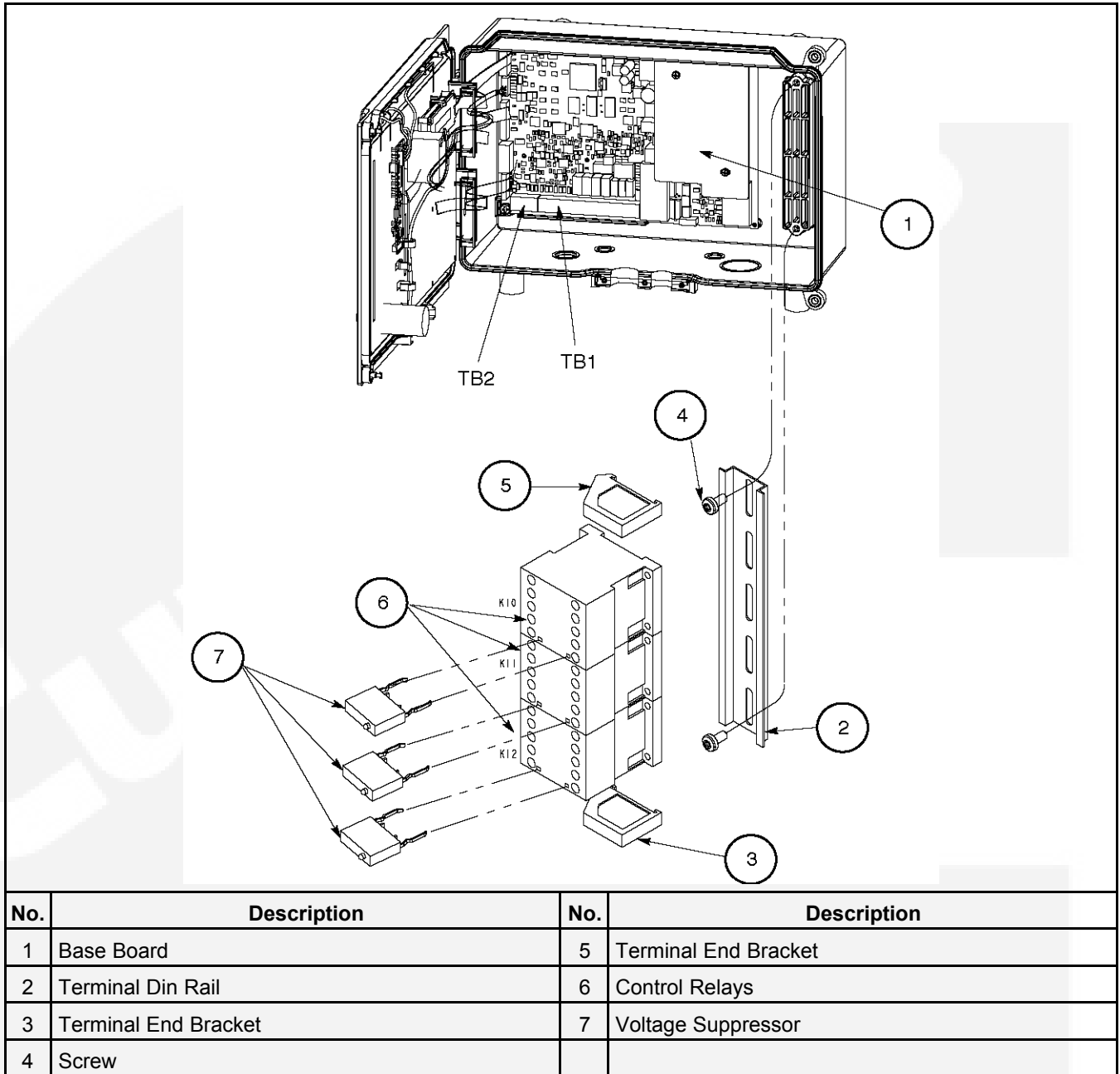

**FIGURE 13. CONTROL PANEL BOX**

This page is intentionally blank.



# 9 AC Electrical Connections

This section provides the procedure that is used to connect the AC electrical system of the generator set.

## WARNING

### ***AC voltages and currents.***

***AC voltages and currents present an electrical shock hazard that can result in severe personal injury or death.***

***Avoid contact with the voltage sense and bus sense leads; voltages of up to 600 VAC may still be present. These voltages could be live even when the generator set is switched off.***

Before making any AC electrical connections, make certain the generator set cannot be accidentally started. Make sure the Operator Panel is in OFF mode. Turn off or remove AC power from the battery charger and then remove the negative (-) battery cable from the set starting battery using an insulated wrench.

If the generator set is being installed in an application where it may parallel with other generators or utility sources, the generator set control system may be energized from an external source. Lock out tag out any external source that can provide AC power to the generator set.

## WARNING

### ***Battery gases.***

***Arcing at battery terminals, a light switch or other equipment, flame, pilot lights, and sparks can ignite battery gases, that can cause severe personal injury or death.***

***Do not smoke or switch a trouble light ON or OFF near a battery.***

***Discharge static electricity from your body before touching batteries by first touching a grounded metal surface.***

***Ventilate the battery area before working on or near a battery.***

***Using an insulated wrench, disconnect the negative (-) cable first and reconnect it last.***

## WARNING

### ***Accidental starting.***

***Accidental starting of the generator set can cause severe personal injury or death.***

***Prevent accidental starting by disconnecting the negative (-) cable from the battery terminal, using an insulated wrench.***

## WARNING

### ***Electrical Maintenance***

***Improper procedures may result in property damage, bodily injury or death.***

***Each of the operations described in this section should be done only by persons trained and experienced in electrical maintenance.***

## WARNING

### ***Electric current.***

***Electric current can cause severe personal injury or death.***

***The AC sensing harness and other cabling will become energized when the generator set is in operation.***

**NOTICE**

Ventilate the battery area before working on or near battery. Wear goggles. Stop the generator set and disconnect the battery charger before disconnecting battery cables. Disconnect negative (-) cable first and reconnect last using an insulated wrench.

**⚠ CAUTION*****Voltage spikes.***

***Disconnecting the battery charger cables from the AC source can result in voltage spikes high enough to damage the DC control circuits of the generator set.***

***Always disconnect a battery charger from its AC source before disconnecting the battery cables.***

Connecting the generator set AC electrical system involves:

- Installation of transfer switch
- Installation or verification of paralleling switchboard
- Generator output voltage selection
- Load cable connection
- Standard and optional AC equipment connections (e.g., control box heater, coolant heater, etc.).

Local regulations often require that wiring connections be made by a licensed electrician, and that the installation be inspected and approved before operation. All connections, wire sizes, materials used, etc. must conform to the requirements of electrical codes in effect at the installation site.

**⚠ WARNING*****Improper wiring.***

***Improper wiring can cause a fire or electrical hazard, resulting in severe personal injury or death and/or property and equipment damage.***

***Wiring should only be carried out by persons trained and experienced in electrical maintenance.***

Before starting the generator set, check to make sure that all electrical connections are secure, and that all wiring is complete. Replace and secure any access panels that have been removed during installation. Check that the load cables from the generator set are properly connected.

**NOTICE**

**Backfeed to a utility system can cause electrocution or property damage. Do not connect to any building electrical system except through an approved device and after the building main switch is opened.**

## 9.1 Transfer Switch

A transfer switch must be used for switching the load from the normal power source to the generator set (see [Figure 14](#)). Follow the installation instructions provided with the transfer switch when connecting the load and control wiring.

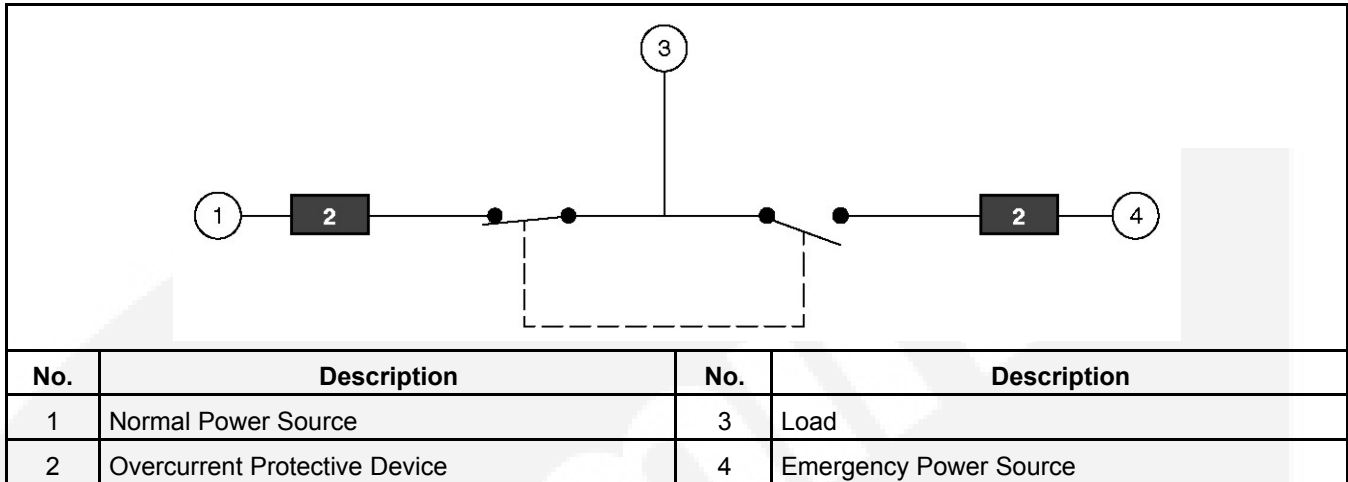

FIGURE 14. TYPICAL LOAD TRANSFER FUNCTION

## 9.2 Generator Voltage Connections

These generators can be configured to the nameplate voltages as shown on the Reconnection Diagram decal, attached to the backside of the control box cover. Many of the voltages listed will require reconfiguration of the generator output leads on the connection terminal block. This reconfiguration must only be done by service personnel that are trained and experienced to perform electrical installation. The generator set was adjusted to produce a specified voltage during production verification testing prior to shipment. The installer must always check the stator lead terminal block connections and perform any necessary reconnect to obtain the voltage required.

Some generator sets are capable of producing a wide range of voltages and connection configurations; others have specific limited capabilities. Refer to wiring diagram and generator voltages (from the nameplate) when reviewing the voltage connection information and use the wiring diagram supplied with your generator set when actually performing load connections.

**NOTICE**

*Reconfiguring generator sets to higher voltages can exceed the voltage capability of the specific generator windings and damage the generator and also decrease line current, rendering line circuit breakers too large. Consult with your authorized distributor before performing reconnection for a different voltage.*

**NOTICE**

*Reconfiguring generator sets to lower voltages can reduce generator set ratings, and also increase line current, rendering line circuit breakers too small. Consult with your authorized distributor before performing reconnection for a different voltage.*

## 9.3 Load Connections

### NOTICE

Flexible conduit and stranded conductors must be used for connections to take up movement of the generator set.

All loads are connected to the generator by bolting stranded load wires to the appropriate terminals on the generator reconnection terminal block or circuit breaker lugs. The terminals are marked U, V, W, and N to indicate the line and neutral connections. (Reference: U, V, and W correspond with L1, L2 and L3; and N with L0 respectively). See [Appendix C on page 81](#) for details about the following:

- Load connections
- Conduit
- Cable Size

## 9.4 Load Balancing

When connecting loads to the generator set, balance the loads so that the current flow from each line terminal (L1, L2, and L3) is about the same. This is especially important if both single phase and three phase loads are connected. Any combination of single phase and three phase loading can be used as long as each line current is about the same, within 10 percent of median value and no line current exceeds the name plate rating of the generator. Check the current flow from each line after connections by observing the Operator Panel ammeter.

## 9.5 Current Transformers

Current transformers (CTs) are used to display generator set load in kVA and alternator amperage.

### 9.5.1 CT Installation Requirements

The CT has a dot on one side. This dot must be facing toward the generator reconnection terminal block (conventional current flowing into the dot). A dot is also used to indicate pin 1 of the CT.

Route the load lead through the appropriate CT (refer to the Reconnection Diagram in [Appendix A on page 61](#)).

The CTs have dual secondary's (3 pins). The CT secondary wire marked 1 is connected to pin 1 of the CT. CT secondary wire marked 2/3 is connected to pin 3 for low voltage generator sets.

## 9.6 Grounding

The following is a brief description of system and equipment grounding of permanently installed AC generators within a facility wiring system.

**⚠ WARNING**

**Electric current.**  
**Electric current can cause severe personal injury or death.**  
**Bonding and grounding must be done properly. All metallic parts that could become energized under abnormal conditions must be properly grounded.**

**NOTICE**

**It is important to follow the requirements of the local electrical code.**

**Figure 15, Figure 16** and **Figure 17** illustrate typical system grounding for a 2-pole, 3-pole, and 4-pole Automatic Transfer Switch (ATS). In the 2-pole and 3-pole ATS, note that the generator neutral is connected to the ATS and is NOT bonded to ground at the generator. In the 4-pole ATS system, a grounding electrode conductor and a bonding jumper are used to connect the generator neutral to ground.

Make sure the generator set is grounded to earth in one location only. On generator sets without a circuit breaker, ground to the point indicated on the top of the generator. On generator sets with circuit breakers, use the ground lug provided in the circuit breaker box.

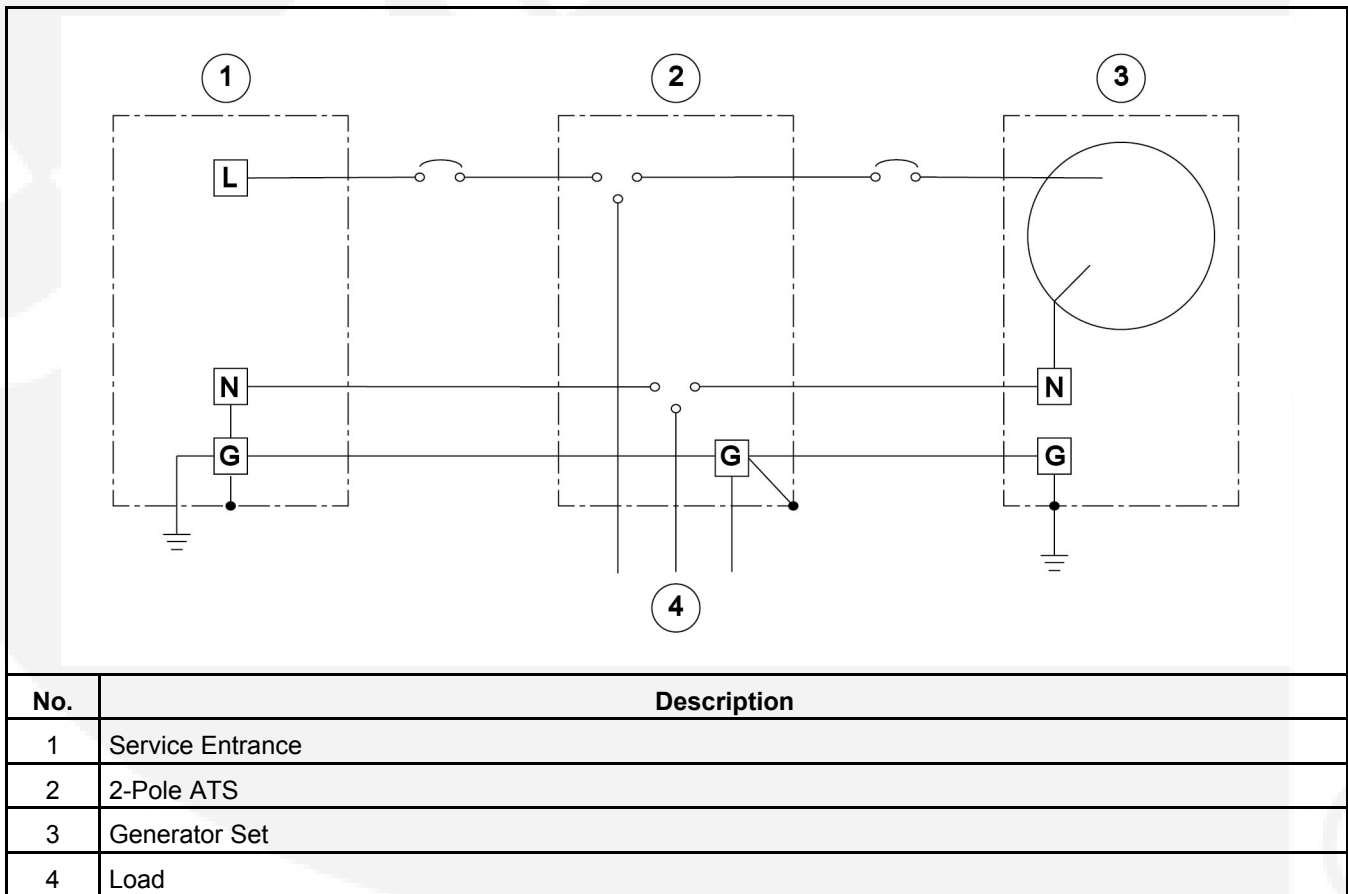

**FIGURE 15. TYPICAL SYSTEM - ONE-PHASE, THREE WIRE UTILITY, TWO-POLE ATS**

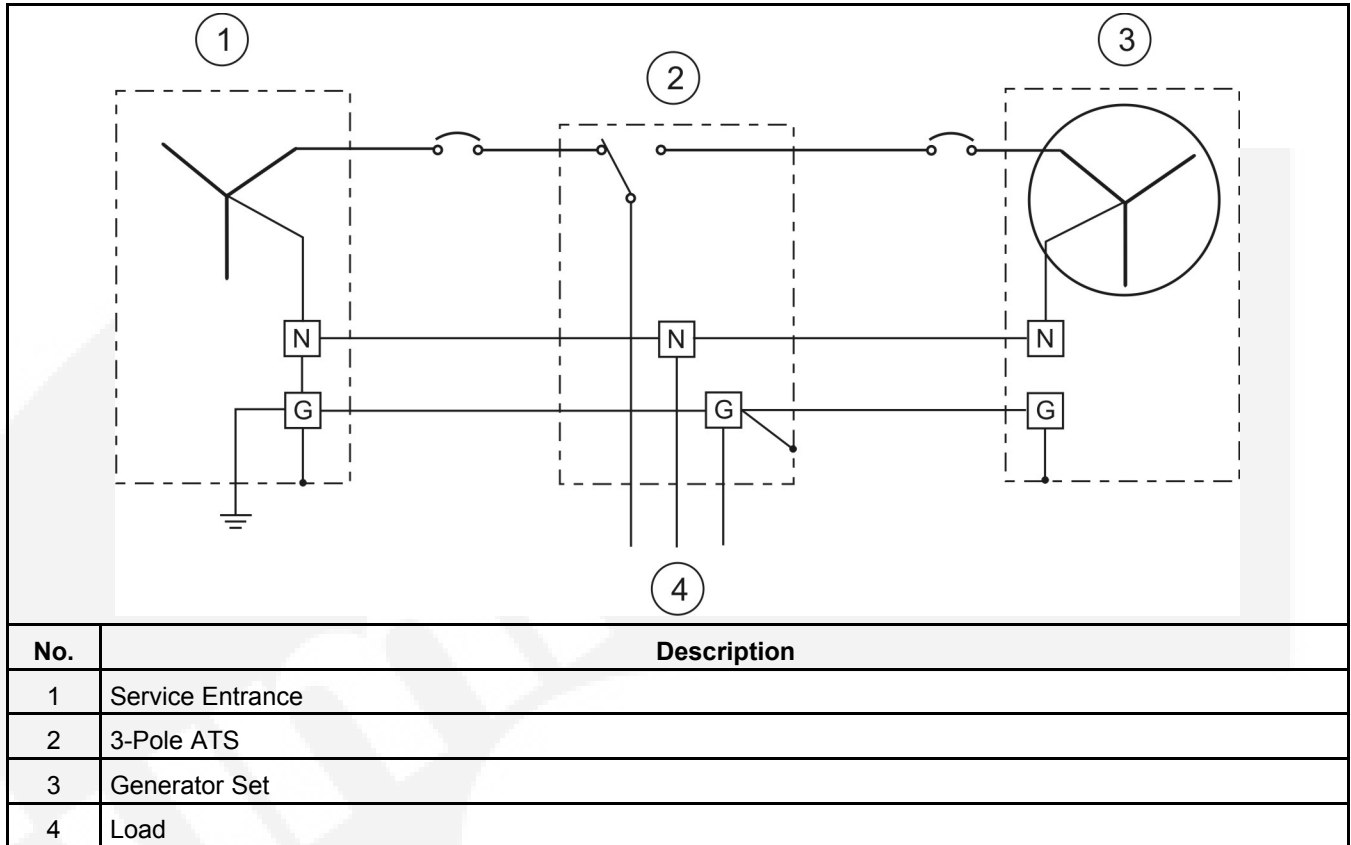

**FIGURE 16. TYPICAL SYSTEM - THREE-PHASE, FOUR WIRE UTILITY, THREE-POLE ATS**

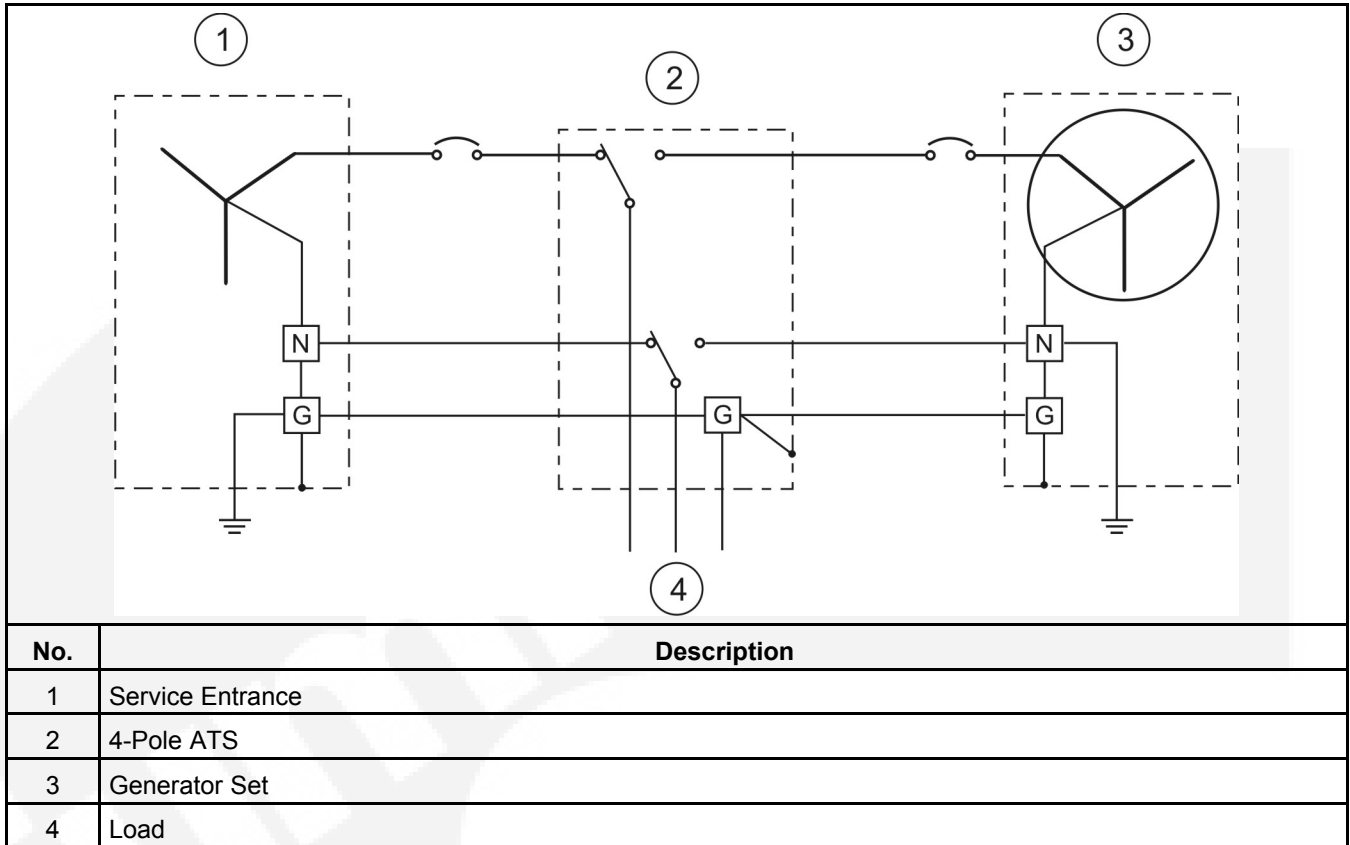

FIGURE 17. TYPICAL SYSTEM - THREE-PHASE, FOUR WIRE UTILITY, FOUR-POLE ATS

## 9.7 Coolant Heater Connection

**NOTICE**

*The coolant heater must not be operated while the cooling system is empty or damage to the heater will occur.*

A coolant heater keeps the engine coolant warm when the engine is shut down. It heats and circulates the coolant within the engine. This reduces start-up time and lessens engine wear caused by cold starts. It is electrically operated and thermostatically controlled.

Refer to [Appendix B](#) for electrical connections.

## 9.8 Alternator Heater (Option)

An alternator heater(s) is used to help keep the alternator free of condensation when the generator set is not running. During cool and humid conditions, condensation can form within a alternator, creating flashing and shock hazards.

**⚠ WARNING**

***Water or moisture inside an alternator increases the possibility of flashing and electrical shock, which can cause equipment damage and severe personal injury or death. Do not use a alternator which is not dry inside and out.***

The figure below shows the installation of two heater elements. Connect the heater(s) terminals to a source of power that will be on during the time the engine is not running. Be sure the supply voltage and circuit amperage is correct for the heater element rating.

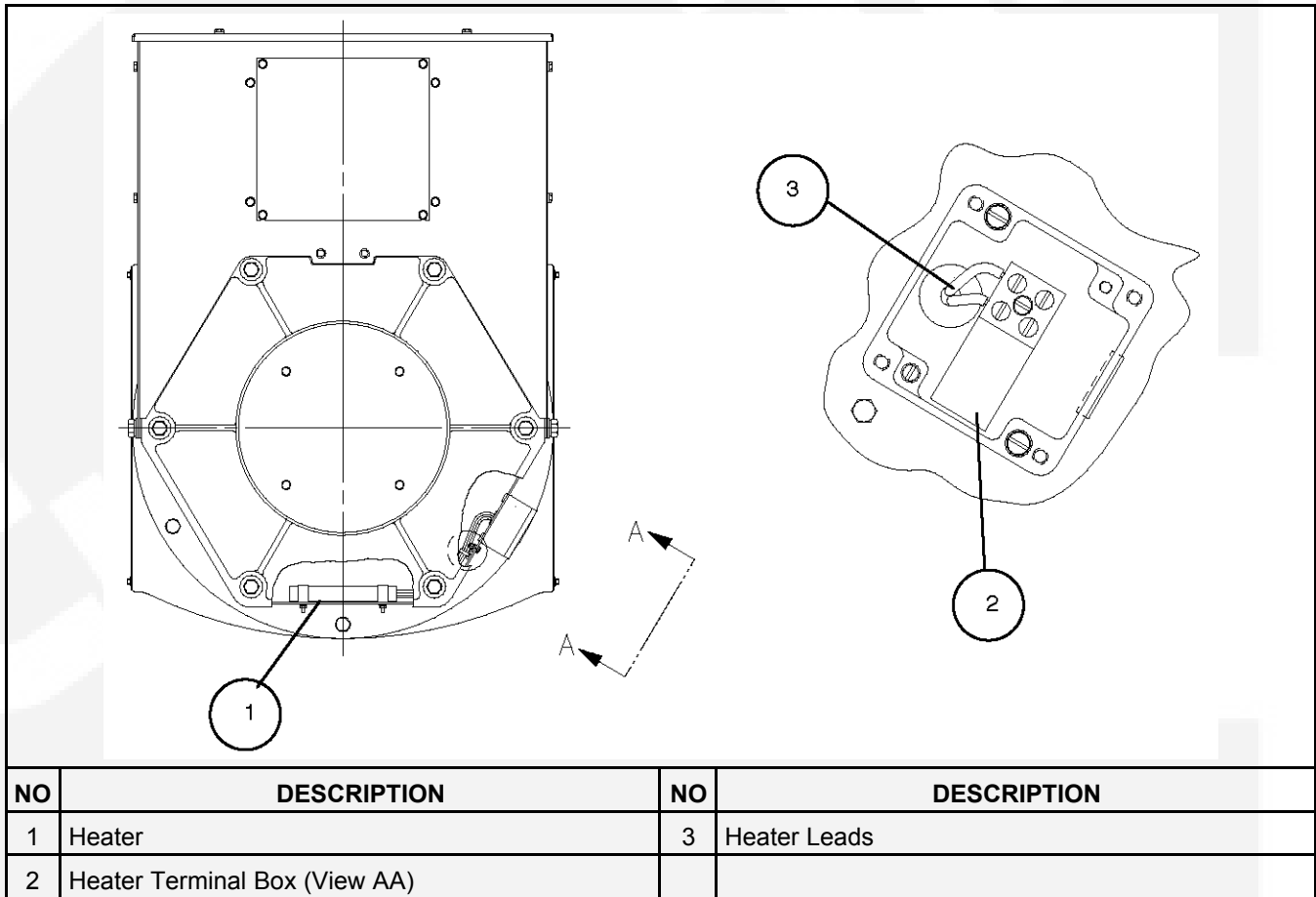

**FIGURE 18. ALTERNATOR HEATER**

# 10 Pre-Start Preparation

---

Before attempting an initial start of the generator set, be sure to complete the Installation Checklist, see [Chapter 11 on page 57](#).

## WARNING

***Make sure that all items listed in the Installation Checklist are carried out before starting the generator set. The failure to do a complete installation can result in equipment damage and severe personal injury or death.***

## 10.1 InPower Service Tool General Information

InPower is a PC based service tool for the PowerCommand 2100 Control (PCC). Use InPower to:

- Make adjustments to the control's trims and settings.
- Perform diagnostics and monitoring.
- Create a capture file of the controls trims and settings.
- Update control calibrations (InPower PRO version).

## NOTICE

**Refer to the InPower User's Guide for specifics.**

### 10.1.1 InPower Adjust Mode

The adjustment feature allows you to make adjustments to genset parameters, calibrations and settings. There are several groups of adjustment parameters; note that not all gensets will have the same adjustments available.

### 10.1.2 InPower Capture File Description

InPower provides a method of extracting (capturing) a device's parameter values. Capturing saves device information in a file that is identified with a .CAP extension.

Capture files are used to store a copy of the genset's parameter values. During genset installation, it is suggested that a capture file be made before and after changes are made to the genset operating parameters. This information can be a very useful when troubleshooting the genset (determine if parameters/settings have been modified after installation) and when replacement of the Base board is necessary. The capture file can be used as a template to write the previous settings to the new Base board software.

## 10.2 Electrical System

Verify all electrical connections are secure and all wiring is complete and inspected. Replace and secure any access panels that may have been removed during installation.

## 10.3 Battery Connections

**⚠ WARNING**

***Accidental starting.***

***Accidental starting of the generator set can cause severe personal injury or death.***

***Make sure that the PowerCommand® Control is in the OFF mode before connecting the battery cables.***

**⚠ WARNING**

***Battery gases.***

***Ignition of explosive battery gases can cause severe personal injury or death.***

***Always connect the negative (-) battery cable last to prevent arcing using an insulated wrench.***

**⚠ WARNING**

***Arching.***

***Arching at battery terminals, light switch or other equipment, flame, pilot lights, and sparks can ignite battery gases and cause severe personal injury or death.***

***Ventilate the battery area before working on or near a battery. Do not smoke, or switch trouble light ON or OFF near a battery. Discharge static electricity from body before touching the batteries by first touching a grounded metal surface.***

Starting the unit requires one or more batteries. For more information on batteries, refer to [Chapter 3 on page 13](#). Connect the positive battery cable, using an insulated wrench, before connecting the negative battery cable to prevent arcing.

If an automatic transfer switch is installed without a built-in charge circuit, connect a separate battery charger. Proper selection and maintenance of batteries and battery chargers is essential for system reliability.

## 10.4 Controller Configuration Relays

The figure below shows a block representation of the Controller Configuration menus.

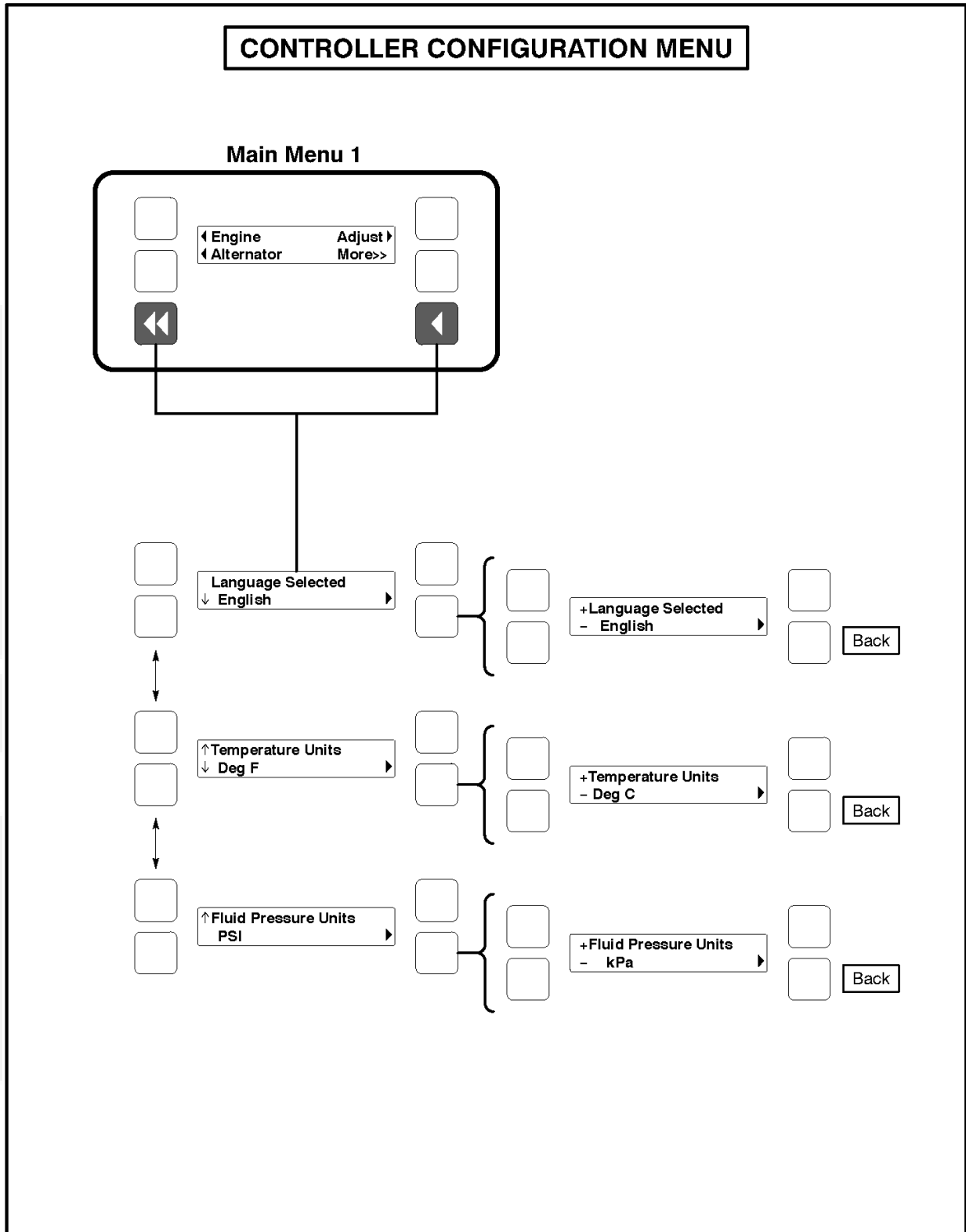

**FIGURE 19. CONTROLLER CONFIGURATION MENU**



To view the first Controller Configuration menu, make sure Main Menu 1 is displayed and simultaneously press the Home Menu and Previous Main Menu buttons.

As shown in the diagram, the Controller Configuration menu has three submenus.

Press the buttons next to the up and down symbols in the digital display to navigate between the menus.

Press the button next to the  symbol in the display until the + and - symbols are displayed.

Press the button next to the + or - symbol to select the desired option.

After selecting option, pressing the  symbol results in the changes being saved. If the Home button or Previous Main Menu button is pressed before pressing the  symbol, the changes are not saved.

**Language Selected submenu:** Used to select desired language (default = English).

**Temperature Units submenu:** Used to select Fahrenheit or Centigrade for temperature readings.

**Fluid Pressure Units submenu:** Used to select PSI or kPA for pressure readings.

## 10.5 Adjust Menu

The figure below shows a block representation of the Adjust Menu. If you press the button next to the word "Adjust" in the display, the first Adjust submenu option is displayed.

As shown in the diagram, the Adjust Menu has five submenus. Each submenu includes a parameter or value that can be changed.

Press the buttons next to the up and down symbols in the digital display to navigate between the menus. Press the Home button or the Previous Main Menu button to return to Main Menu 1.

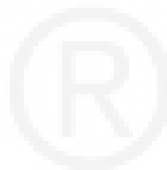

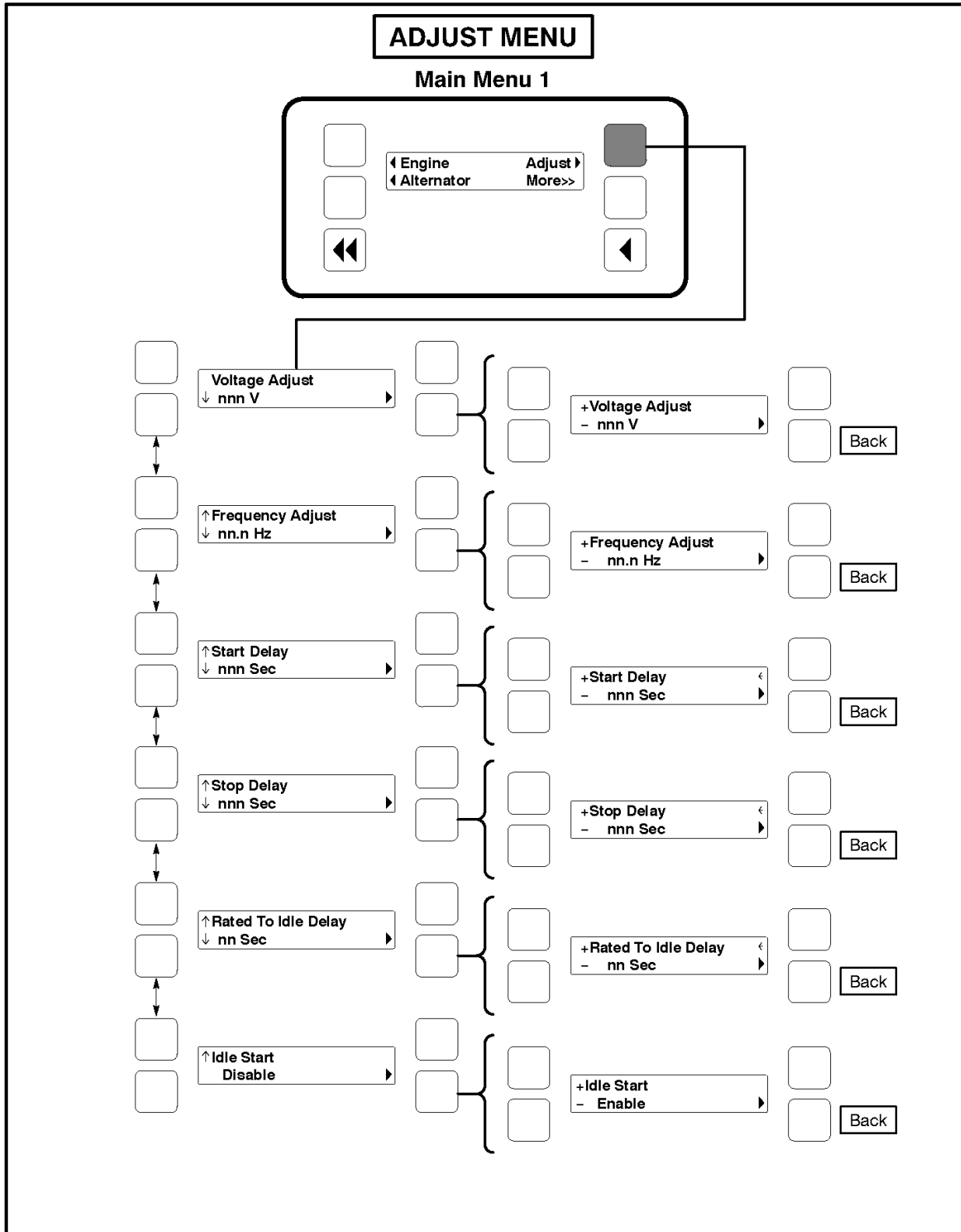

FIGURE 20. ADJUST MENU

## 10.5.1 Adjusting Values/Parameters

1. Press the button next to the arrow symbol in the display until the + and - symbols are displayed.
2. If necessary, press the button next to the  $\leftarrow$  or  $\rightarrow$  symbols to move to the numeric character you wish to change.
3. Press the button next to the + symbol to increase the value or select parameter; press the button next to the - symbol to decrease the value or select parameter.
4. After adjusting values/selecting parameters, pressing the arrow symbol results in the changes being saved. (When adjusting values, make sure the cursor is on the last numeric character before pressing the arrow symbol).

If the Home button or Previous Main Menu button is pressed before pressing the arrow symbol, the changes **are not** saved.

## 10.5.2 Adjust Submenus

- **Voltage Adjust submenu:** Voltage can be adjusted to  $\pm 5$  percent of the nominal voltage. For example, if genset output voltage is 208 volts, the voltage can be adjusted from 197 to 218 volts.

If the revised value is greater or less than the allowed (5%) range, the control will round off the displayed value (up or down). For example, if changing the value by -5% (maximum) equals 197.6, the display will show 197, but will display and change the output to 198 when saved.

- **Frequency Adjust submenu:** Frequency can be adjusted to  $\pm 5$  percent of the nominal frequency. For example, if the genset frequency is 60.0 Hz, the frequency can be adjusted from 57.0 to 63.0 Hz.
- **Start Delay submenu:** Start Delay can be set from 0 to 300 seconds (default = 0). This function is bypassed during a manual start/stop sequence.
- **Stop Delay submenu:** Stop Delay can be set from 0 to 600 seconds (default = 0). This function is bypassed during a manual start/stop sequence and engine shutdown faults.
- **Rated To Idle (Beginning Version 2.303):** Rated To Idle delay can be set from 0 to 10 seconds (default = 0). (Enter 1 or more to enable.) Entering a non-zero delay will cause the genset to delay the transition to Cooldown At Idle.
- **Idle Start submenu (Only available on some models):** Idle Start can be enabled or disabled (default = Disable). This function is only enabled when the genset is started in manual mode. Idle Start can also be enabled while the set is running in manual mode.

Enabling Idle Start will cause the genset to run in idle mode until Idle Start is disabled. A warning is displayed if genset is left in idle more than 10 minutes. Long periods of engine idling can eventually affect engine performance and may void engine warranty.

## 10.6 Starting

Refer to the generator set Operator manual for important safety precautions and recommended procedures for starting the generator set and verifying proper operation. Start the generator set and verify all engine and generator menus are displaying the correct values.

# 11 Installation Checklist

Tick	General Items
	Generator set wattage capacity is sufficient to handle maximum anticipated load.
	At least 3 feet of clearance (or greater for housing door) is provided around the entire generator set for service and ventilation.
	The generator set is located in an area not subject to flooding.
	All operating personnel have read and are familiar with Generator Set Operator manual and Health And Safety manual.
	All operators have been thoroughly briefed on preventative maintenance procedures.
	All operators have read and understand all important safety instructions.
	<b>Generator Set Support</b>
	Floor, roof or earth on which the generator set rests is strong enough and will not allow shifting or movement. Observe local codes on soil bearing capacity due to freezing and thawing.
	Generator set is properly supported and retained to approved base
	Supporting base is large enough and is of non-combustible material, extending 6 inches all around the generator set.
	<b>Cooling Air Flow</b>
	Generator set air inlet is faced into direction of strongest, prevailing winds.
	Air inlet openings are unrestricted and at least 1 to 1½ times larger than air outlet area.
	Cooling air outlet is on downwind side of building (if not, wind barrier is constructed).
	Proper ducting material (Sheet metal, canvas) is used between radiator and air outlet.
	<b>Natural Gas/LP Vapor/LPG Liquid Fuel System</b>
	Fuel lines are properly installed, supported and protected against damage.
	Approved flexible fuel line is installed between main fuel supply and generator set's fuel system near the generator set, to protect it against damage caused by vibration, expansion and contraction.
	Fuel supply shutoff valves are installed to prevent fuel flow in case of leaks.
	Fuel system is properly primed.
	No fuel leaks are found in supply line or engine fuel system.
	Check the fuel line and use equations to verify that it has proper volume capability.
	Check if fuel pressure is between 7-13 inches water column.
	Make sure fuel pressure does not drop below 7 inches water column under full load.
	If necessary, perform initial demand regulator adjustment procedure.
	<b>Exhaust System</b>
	Operators are thoroughly briefed on the dangers of carbon monoxide gas.
	Areas around generator set are well ventilated. No possibility of exhaust fumes entering building doors, windows, or intake fans.
	Exhaust gases are piped safely outside and away from building.
	The correct length of approved rigid pipe is connected to the generator set flexible pipe using approved securing methods with no weight resting on engine exhaust components. There are no bends in flex section.
	Condensation drain is provided in lowest section of exhaust piping.

	Exhaust piping is insulated to guard against burns to personnel.
	Exhaust piping passing through walls or ceilings have approved fire-proof materials and are in compliance with all codes.
	Exhaust piping is large enough in diameter to prevent excessive back pressure on engine.
	<b>AC and DC Wiring</b>
	Wire sizes, insulation, conduits and connection methods all meet applicable codes.
	AC and DC wires are separated in their own conduit to prevent electrical induction.
	All load, line and generator connections are well made and correct.
	Flexible conduit is used between generator and building or surrounding structure.
	<b>Generator Set Pre-Start</b>
	Generator set engine is properly serviced with oil and coolant.
	Batteries are properly installed, serviced and charged.
	Battery charger and engine coolant heater are connected and operational.
	All generator set covers and safety shields are installed correctly.
	All fuel and coolant shutoff valves are operational.
	Radiator Fan and other external moving parts including drive belts are unrestricted.

# 12 Manufacturing Facilities

<b>NORTH AMERICA</b>	<b>EMEA, CIS</b>	<b>ASIA PACIFIC</b>
Cummins Power Generation Limited 1400 73rd Ave. NE Minneapolis, MN 55432 USA	Cummins Power Generation Limited Columbus Avenue Manston Park Manston, Ramsgate Kent CT12 5BF United Kingdom	Cummins Power Generation Limited 10 Toh Guan Road #07-01 TT International Tradepark Singapore 608838
Phone +1 763 574 5000 Toll Free +1 800 888 6626 Fax +1 763 574 5298	Phone +44 1843 255000 Fax +44 1843 255902	Phone +65 6417 2388 Fax +65 6417 2399
<b>BRAZIL</b>	<b>CHINA</b>	<b>INDIA</b>
Rua Jati, 310, Cumbica Guarulhos, SP 07180-900 Brazil	Cummins Power Generation 2 Rongchang East Street, Beijing Economic – Technological Development Area Beijing 100176, P.R.China	35A/1/2, Erandawana Pune 411 038 India
Phone +55 11 2186 4195 Fax +55 11 2186 4729	Phone +86 10 5902 3000 Fax +86 10 5902 3199	Phone +91 020 6602 7525 Fax +91 020 6602 8090
<b>LATIN AMERICA</b>	<b>MEXICO</b>	
3350 Southwest 148th Ave. Suite 205 Miramar, FL 33027 USA	Eje 122 No. 200 Zona Industrial San Luis Potosi, S.L.P. 78395 Mexico	
Phone +1 954 431 551 Fax +1 954 433 5797	Phone +52 444 870 6700 Fax +52 444 824 0082	



This page is intentionally blank.

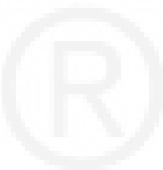

# Appendix A. GGPA/B/C Wiring Diagram with PowerCommand 2100 Control

---

## Table of Contents

Figure 21. A029P864 Sheet 1 .....	63
Figure 22. A029P864 Sheet 2 .....	64
Figure 23. A029P864 Sheet 3 .....	65
Figure 24. A029P864 Sheet 4 .....	66
Figure 25. A029P864 Sheet 5 .....	67

This page is intentionally blank.

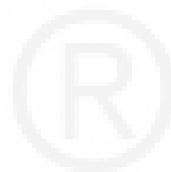



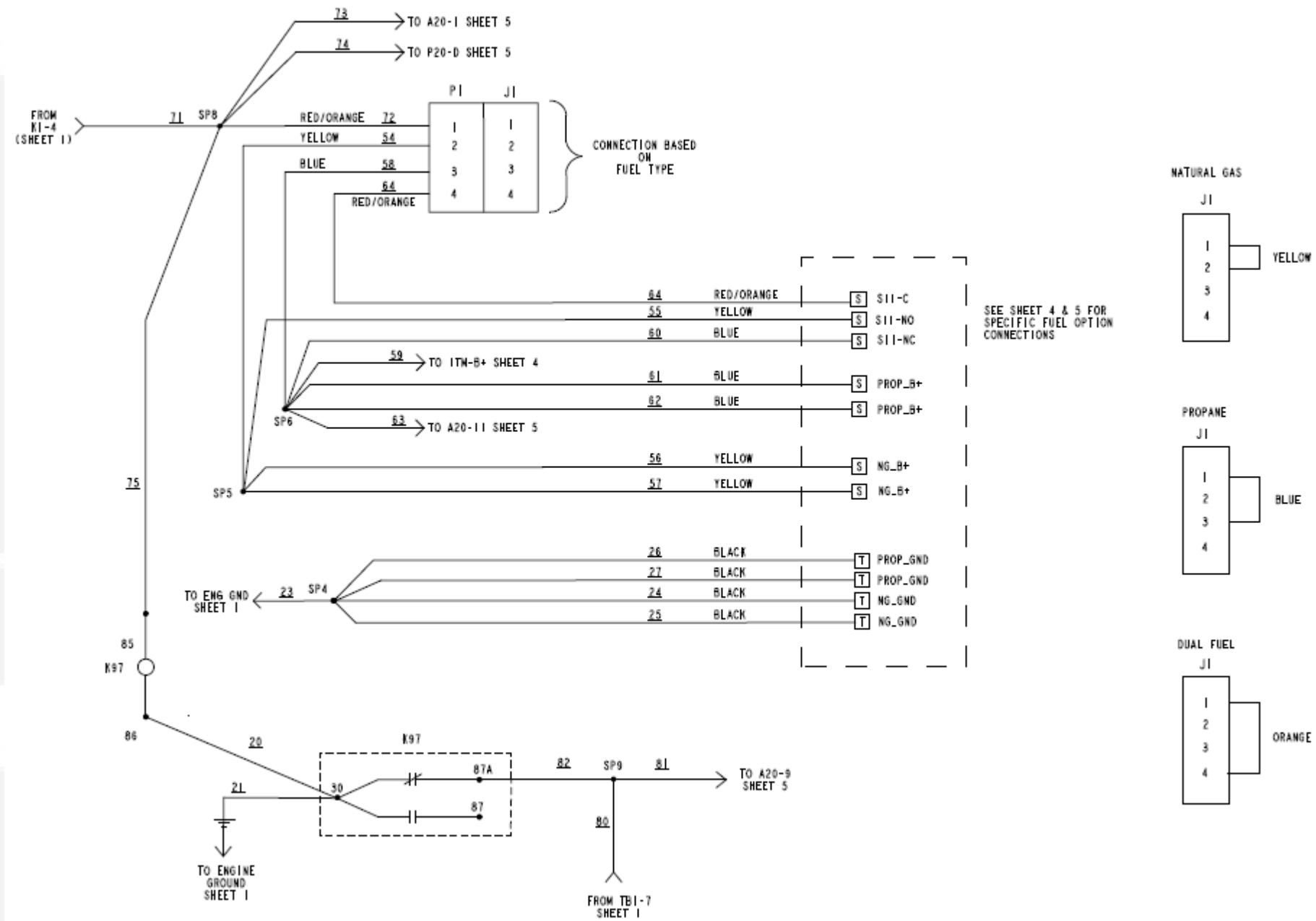

FIGURE 22. A029P864 SHEET 2

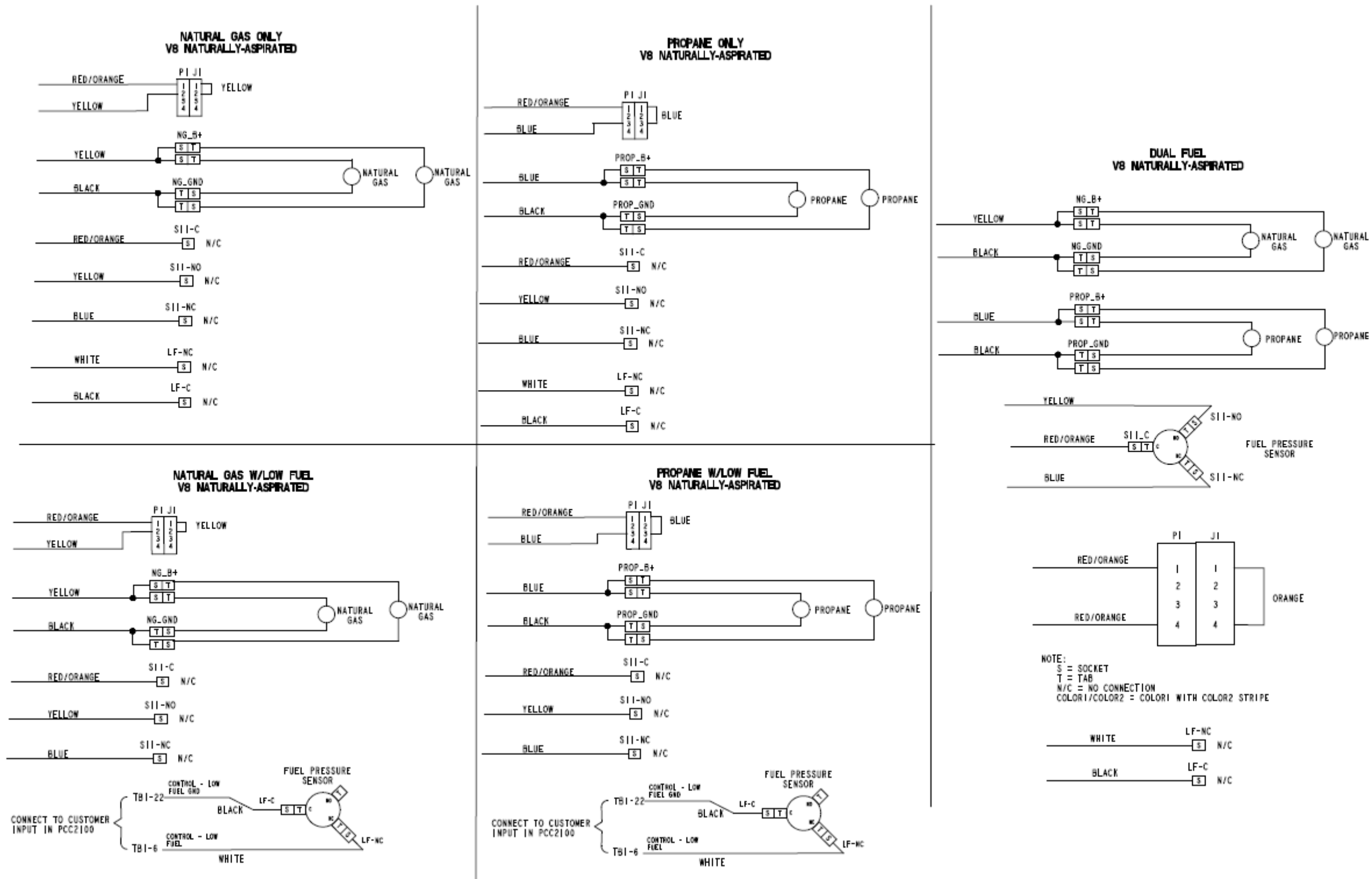

FIGURE 23. A029P864 SHEET 3

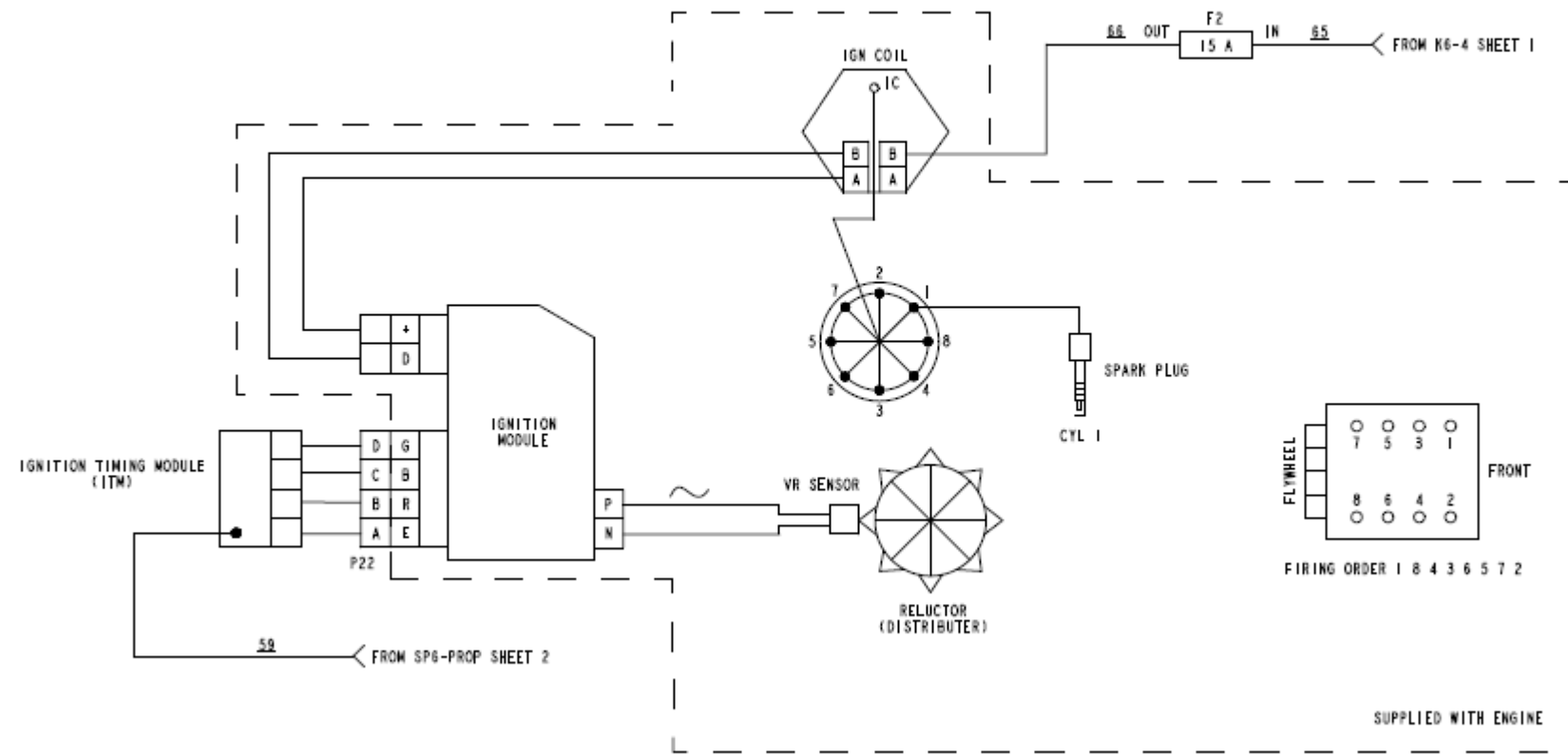

FIGURE 24. A029P864 SHEET 4

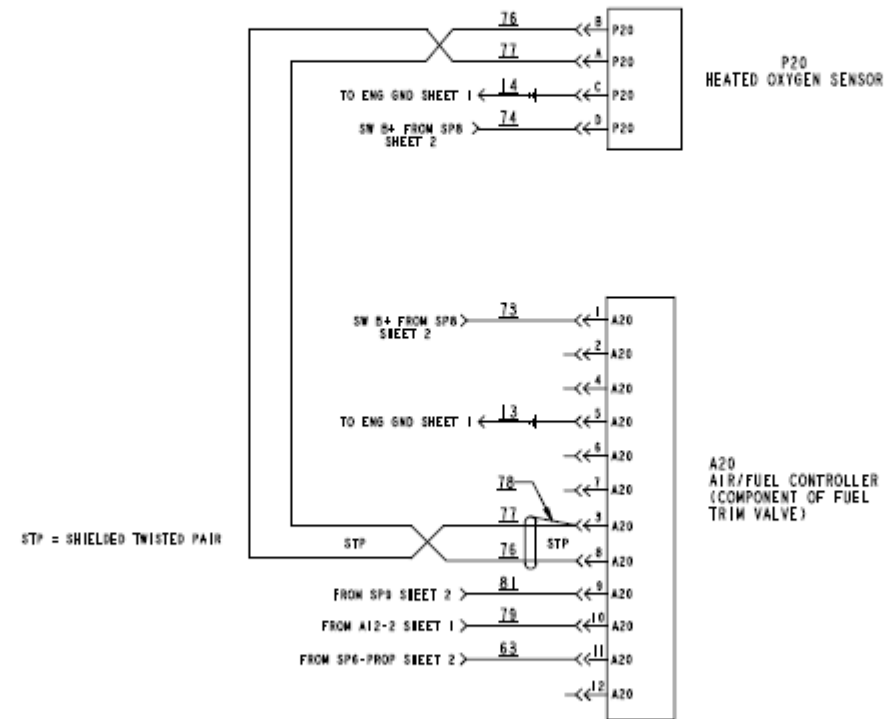
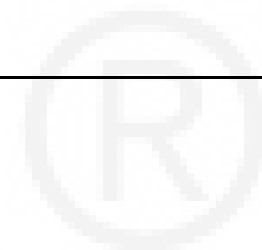
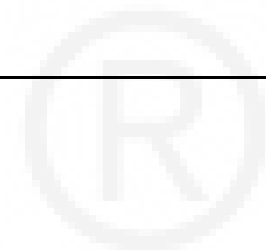

FIGURE 25. A029P864 SHEET 5



This page is intentionally blank.



# Appendix B. Wiring Diagrams

---

## Table of Contents

Figure 26. AC Reconnect Wiring Diagram (Sheet 1 of 2) .....	71
Figure 27. AC Reconnect Wiring Diagram (Sheet 2 of 2) .....	72
Figure 28. Customer Connections .....	73
Figure 29. Wiring Diagram - Generator Reconnect (Sheet 1 of 5) .....	74
Figure 30. Wiring Diagram (Sheet 2 of 5) .....	75
Figure 31. Wiring Diagram (Sheet 3 of 5) .....	76
Figure 32. Wiring Diagram (Sheet 4 of 5) .....	77
Figure 33. Wiring Diagram (Sheet 5 of 5) .....	78
Figure 34. Genset Wiring Harness .....	79

---

Note: This section contains basic (generic) wiring diagrams and schematics for the controller and generator set.



UC GENERATORS

3 PHASE RECONNECTABLE, 12 LEAD

1 PHASE RECONNECTABLE, 12 LEAD

1 PHASE NON-RECONNECTABLE, 4 LEAD

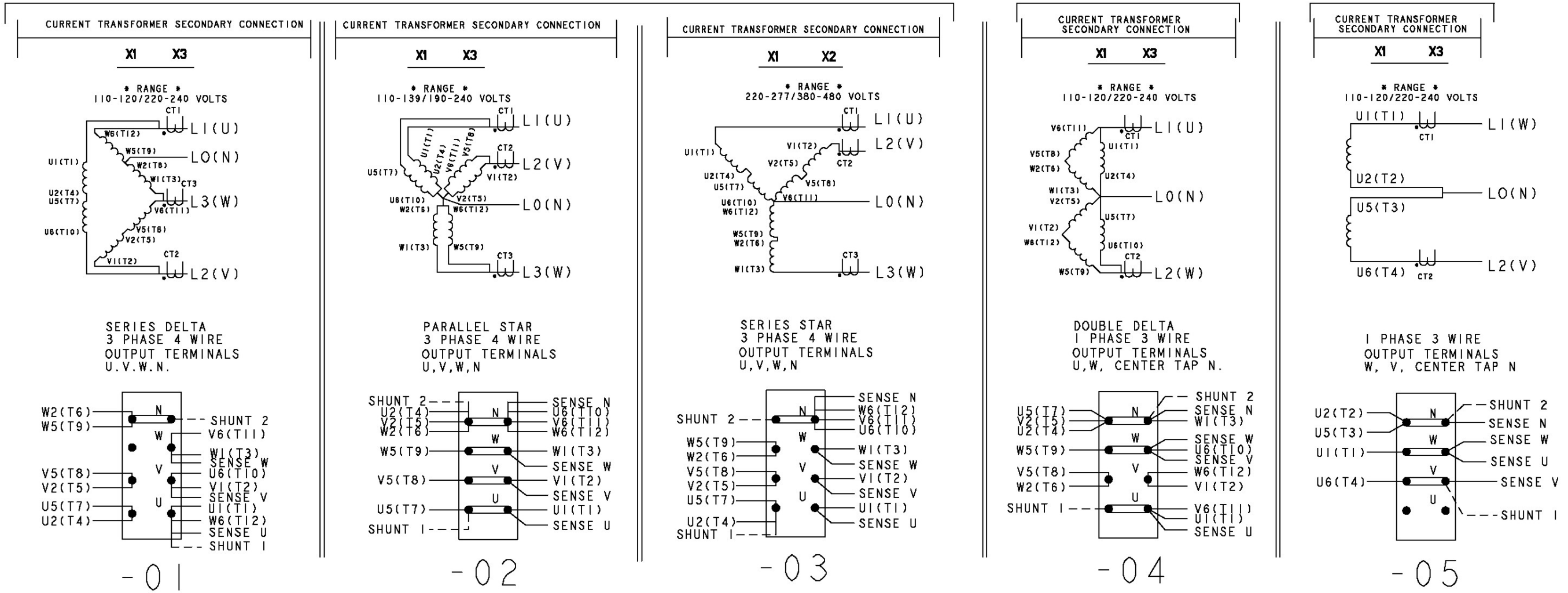

FEATURE CODE	VOLTAGE	50HZ		60HZ	
		WINDING 11	WINDING 11	WINDING 14	WINDING 14
R028	110/220	X	-	-	X
R071	115/230	X	-	-	X
R106	120/240	X	X	-	X

NOTE: SENSE LEAD N IS NOT USED. TAPE END AND TIE BACK.

FEATURE CODE	VOLTAGE	50HZ		60HZ	
		WINDING 11	WINDING 11	WINDING 14	WINDING 14
R004	110/190	X	-	-	X
R050	115/200	X	-	-	X
R098	120/208	X	X	-	X
R020	127/220	X	X	-	-
R067	139/240	-	X	-	-

FEATURE CODE	VOLTAGE	50HZ		60HZ	
		WINDING 11	WINDING 11	WINDING 14	WINDING 14
R099	220/380	X	-	-	X
R029	230/400	X	-	-	X
R003	240/416	X	X	-	X
R023	255/440	X	X	-	-
R002	277/480	-	X	-	-

FEATURE CODE	VOLTAGE	50HZ		60HZ			
		2/3 OUTPUT	FULL OUTPUT	WINDING 11	FULL OUTPUT	WINDING 14	FULL OUTPUT
R046	110/220	X	X	-	-	X	-
R041	115/230	X	X	-	-	X	-
R104	120/240	X	X	X	X	X	-

FEATURE CODE	VOLTAGE	50HZ		60HZ	
		WINDING 11	WINDING 11	WINDING 14	WINDING 14
R046	110/220	-	-	-	X
R041	115/230	-	-	-	X
R104	120/240	-	-	-	X

- NOTES:
1. UVW PHASE SEQUENCE WITH C.W. ROTATION FACING DRIVE END.
  2. WHEN RECONNECTING GENERATOR LEADS, BOLTS SHOULD BE TORQUED AT 22 0942 FT-LBS.

**THIS IS A REPRESENTATIVE (GENERIC) SCHEMATIC/WIRING DIAGRAM. FOR TROUBLESHOOTING, REFER TO THE WIRING DIAGRAM PACKAGE THAT WAS SHIPPED WITH THE GENERATOR SET.**

No. 630-2404, Revision D  
Sheet 1 of 2, Dated January 2004

FIGURE 26. AC RECONNECT WIRING DIAGRAM (SHEET 1 OF 2)

# UC GENERATORS

THIS IS A REPRESENTATIVE (GENERIC) SCHEMATIC/WIRING DIAGRAM. FOR TROUBLESHOOTING, REFER TO THE WIRING DIAGRAM PACKAGE THAT WAS SHIPPED WITH THE GENERATOR SET.

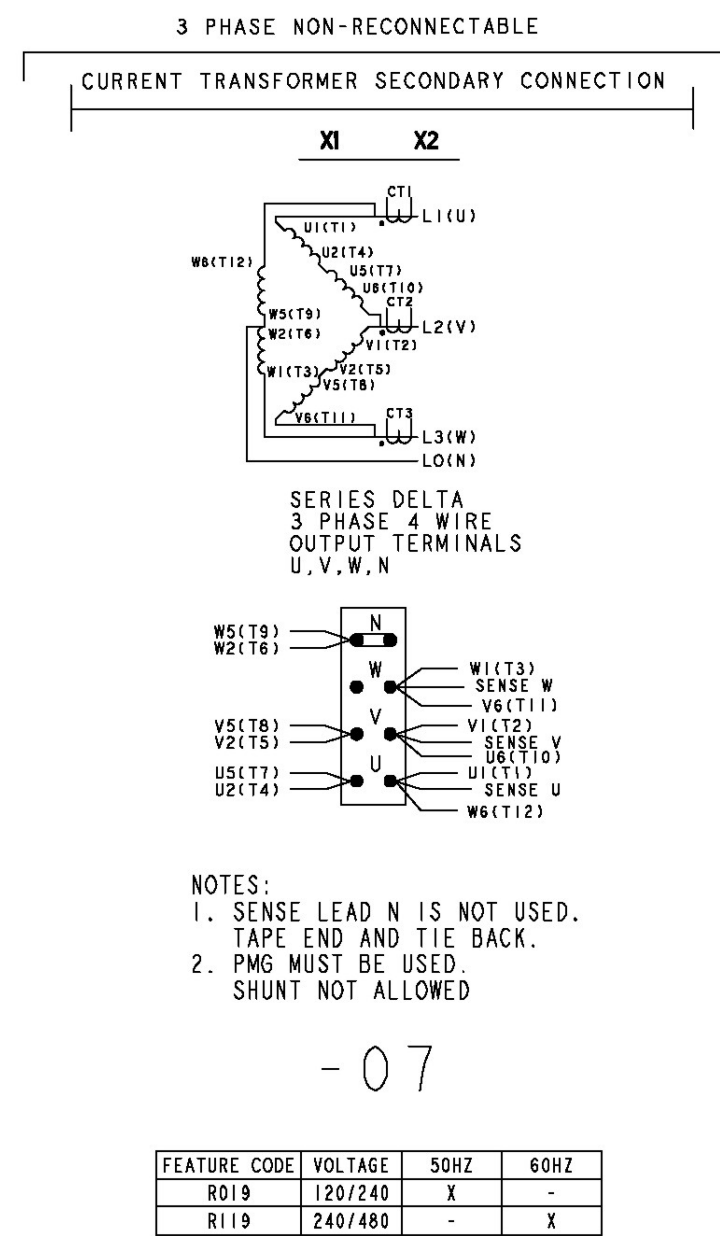
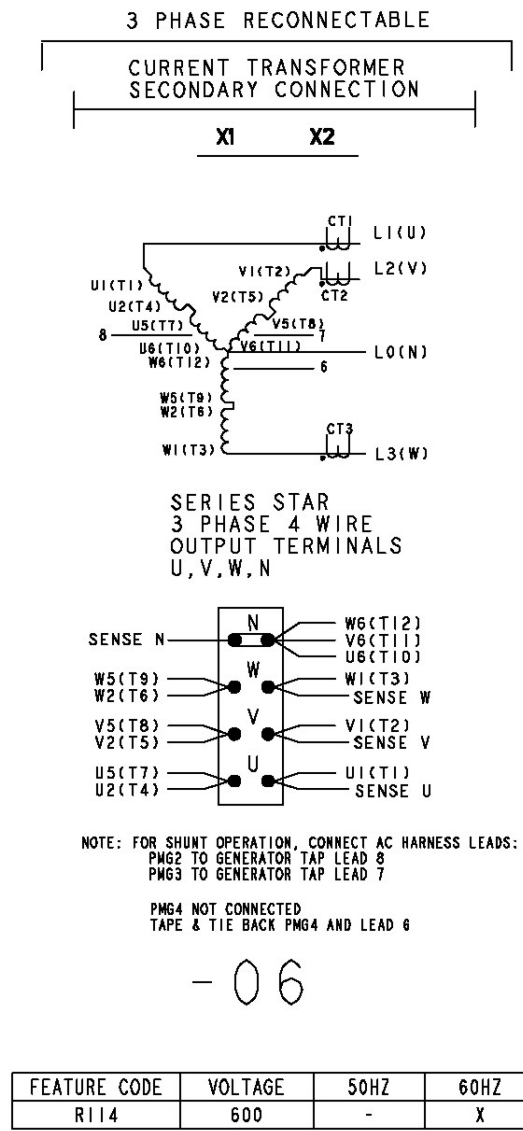
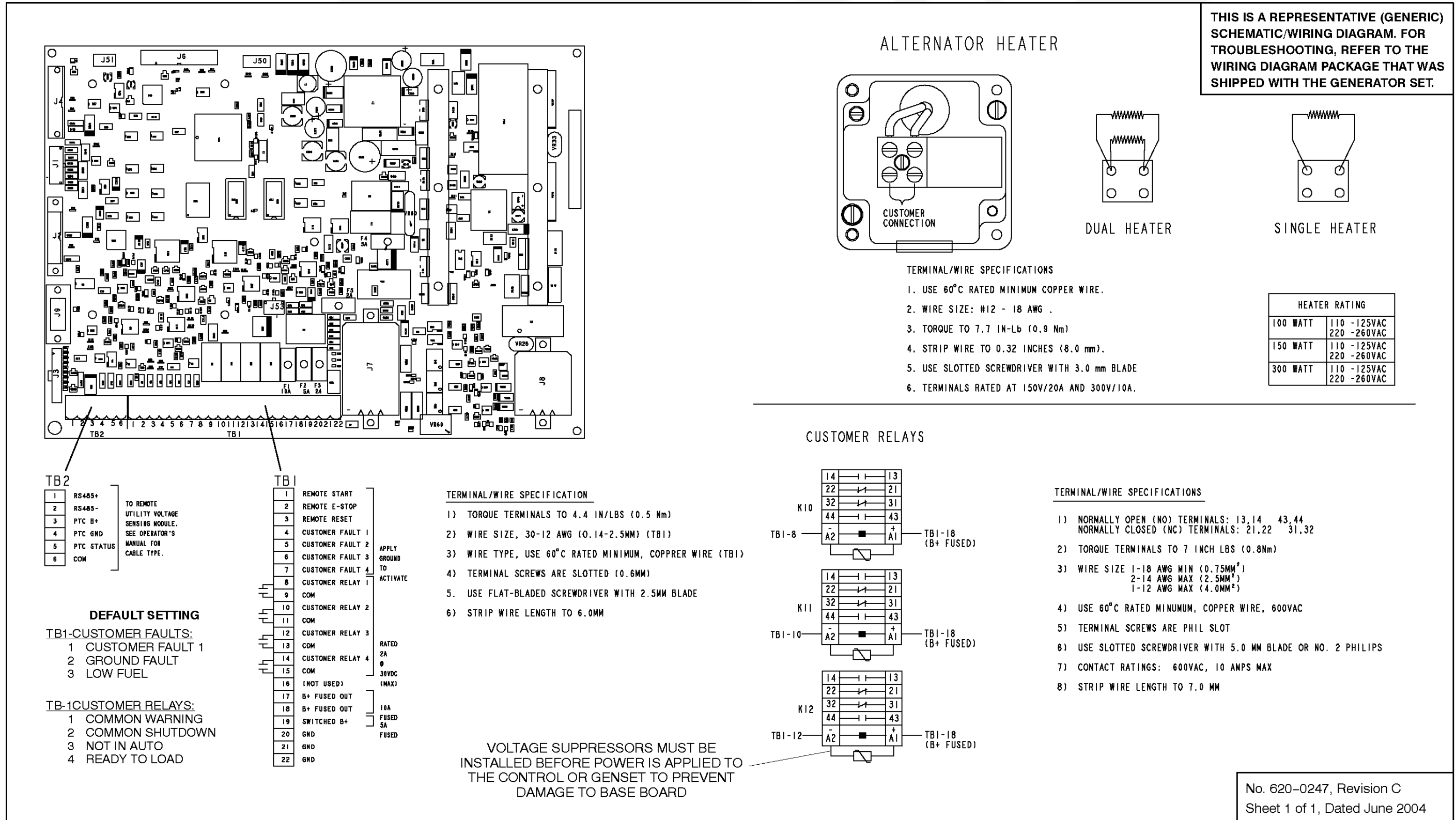

FIGURE 27. AC RECONNECT WIRING DIAGRAM (SHEET 2 OF 2)

No. 630-2404, Revision D  
Sheet 2 of 2, Dated January 2004



**FIGURE 28. CUSTOMER CONNECTIONS**

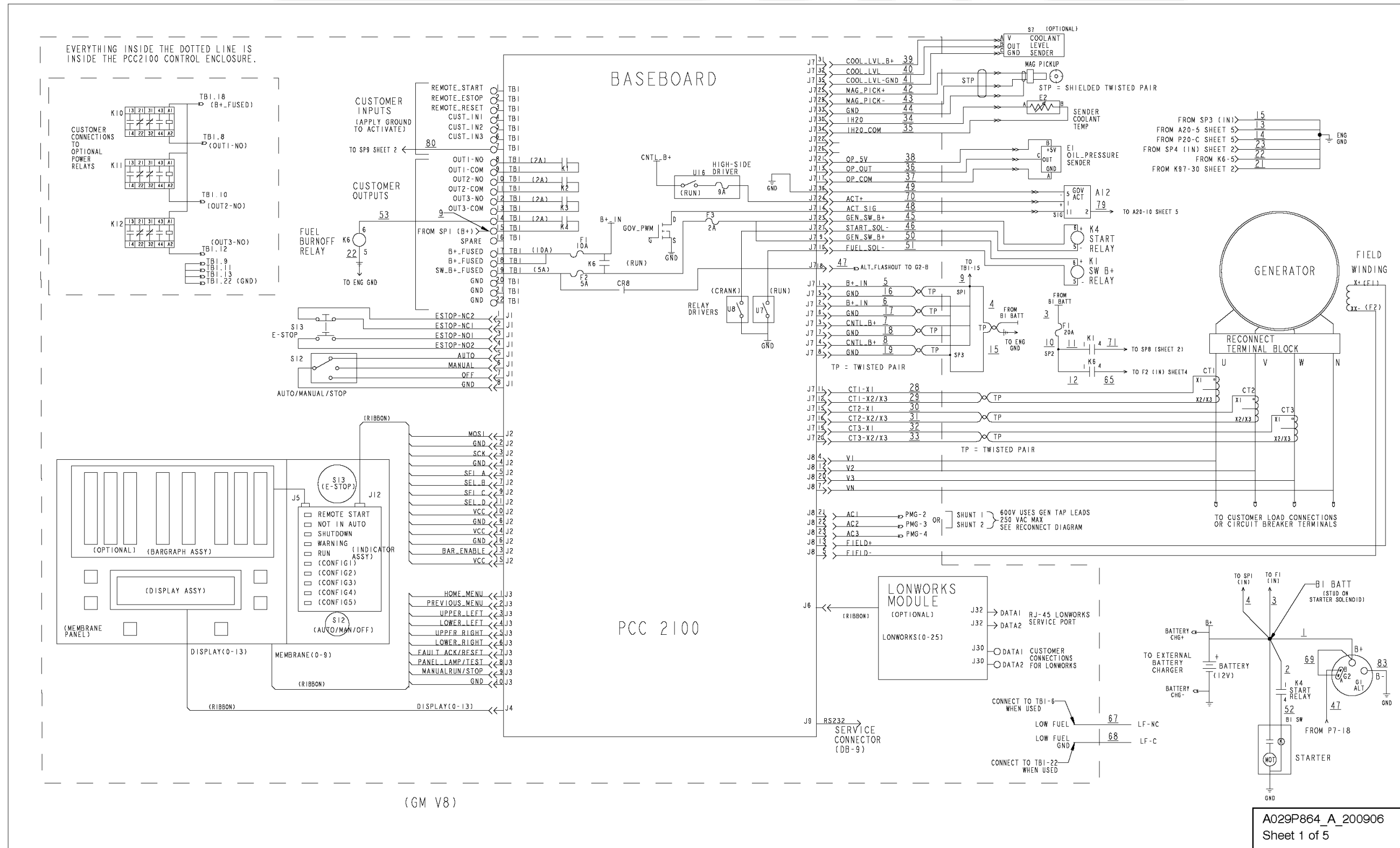
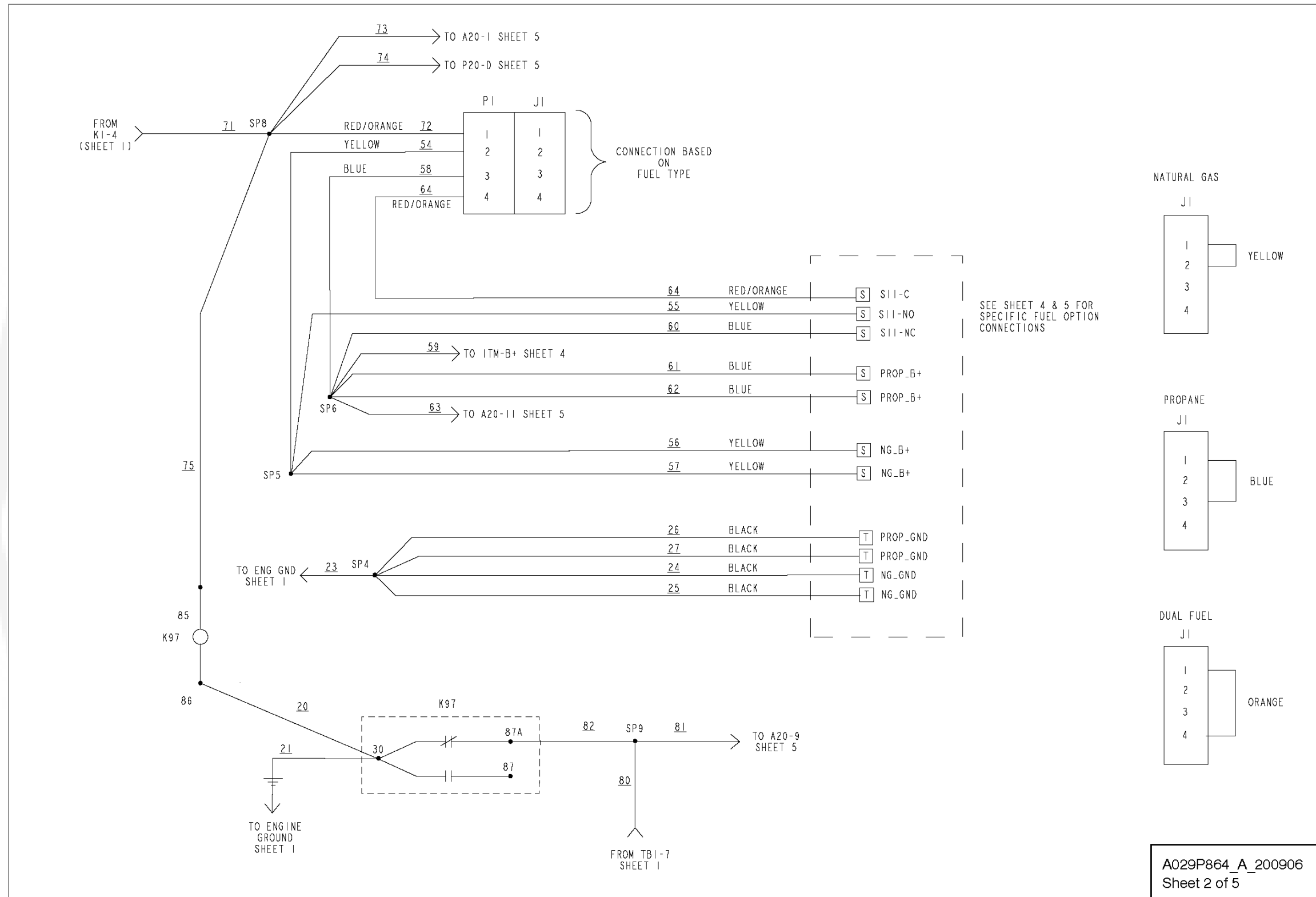

FIGURE 29. WIRING DIAGRAM - GENERATOR RECONNECT (SHEET 1 OF 5)



A029P864\_A\_200906  
Sheet 2 of 5

FIGURE 30. WIRING DIAGRAM (SHEET 2 OF 5)

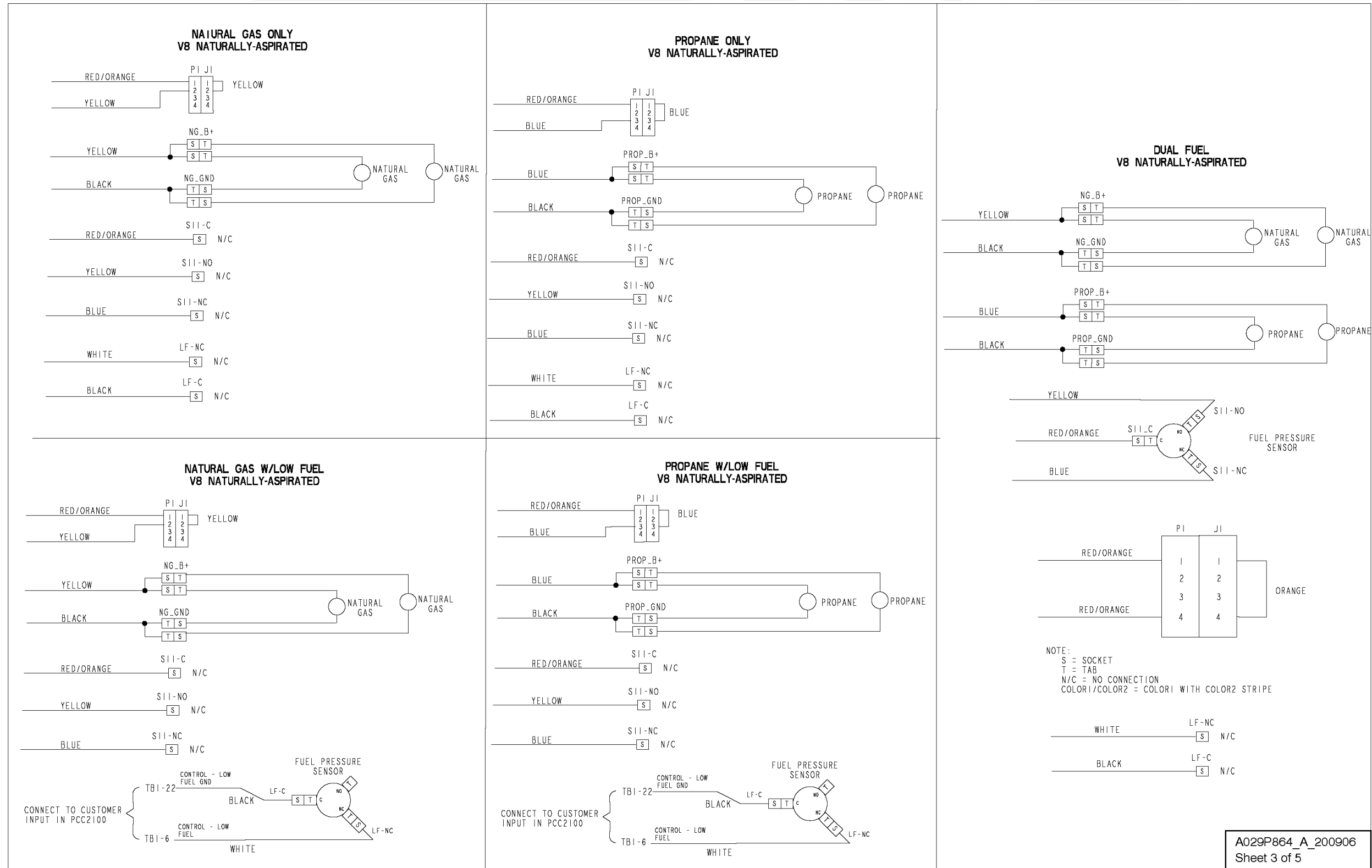
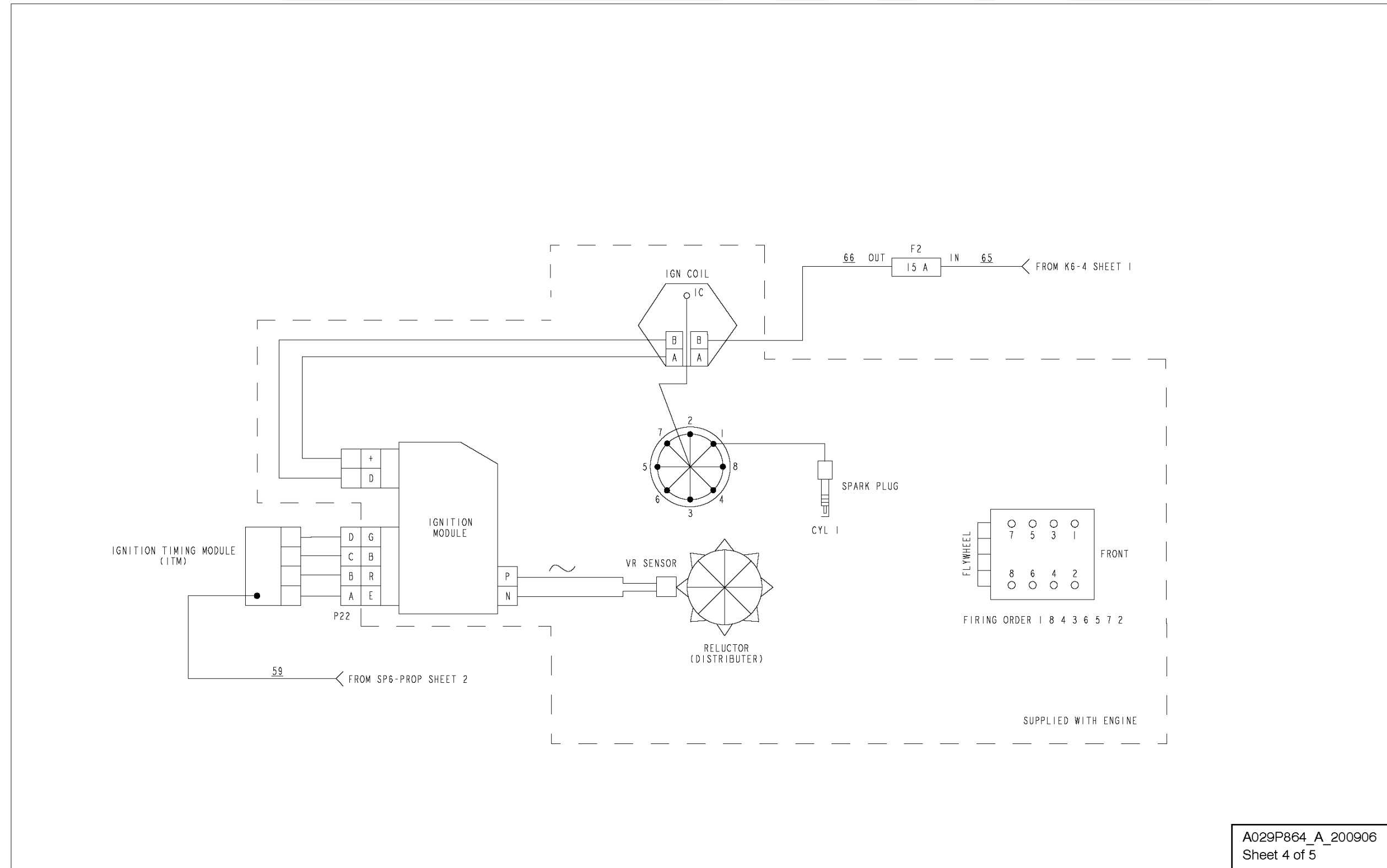

FIGURE 31. WIRING DIAGRAM (SHEET 3 OF 5)



A029P864\_A\_200906  
Sheet 4 of 5

FIGURE 32. WIRING DIAGRAM (SHEET 4 OF 5)

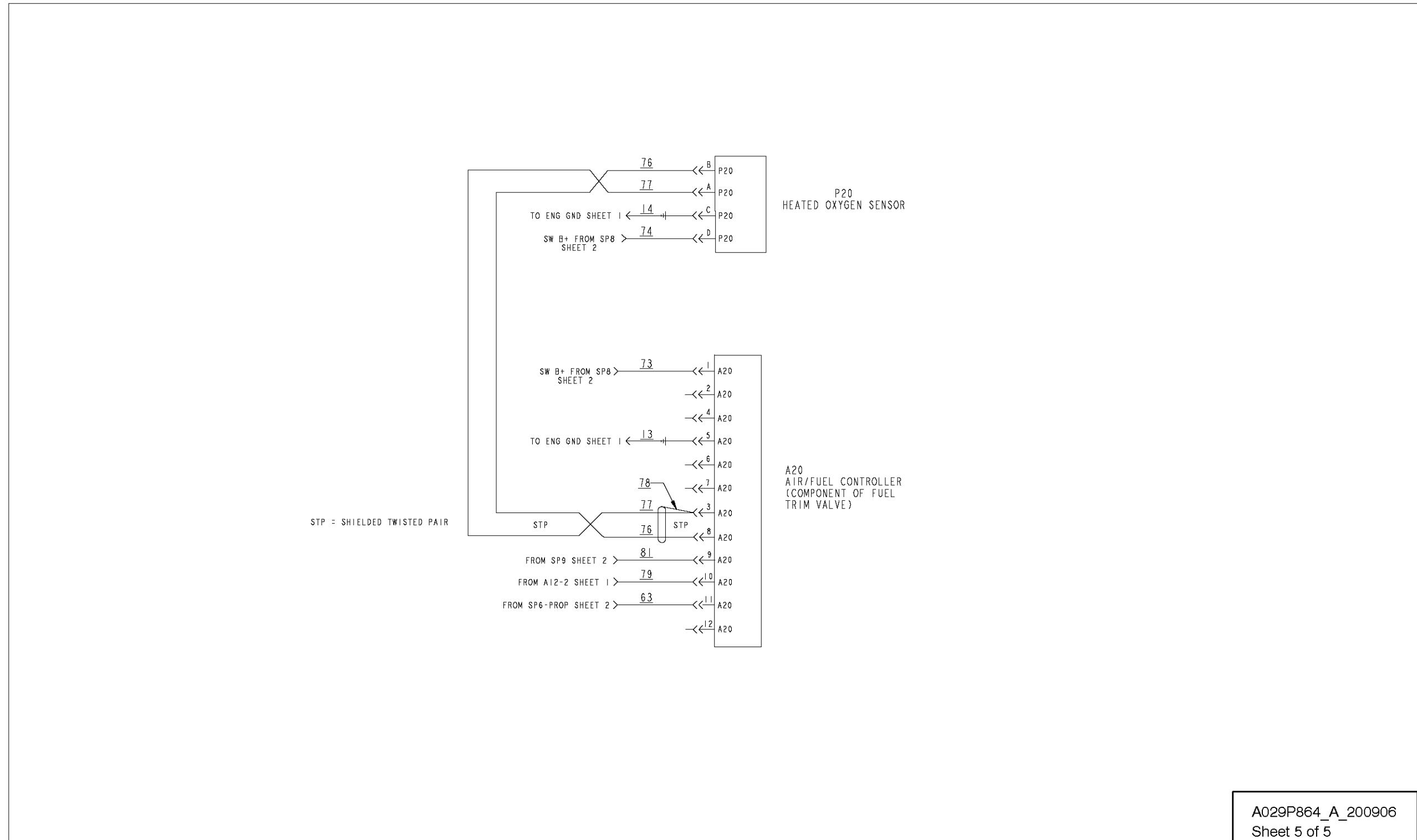

FIGURE 33. WIRING DIAGRAM (SHEET 5 OF 5)

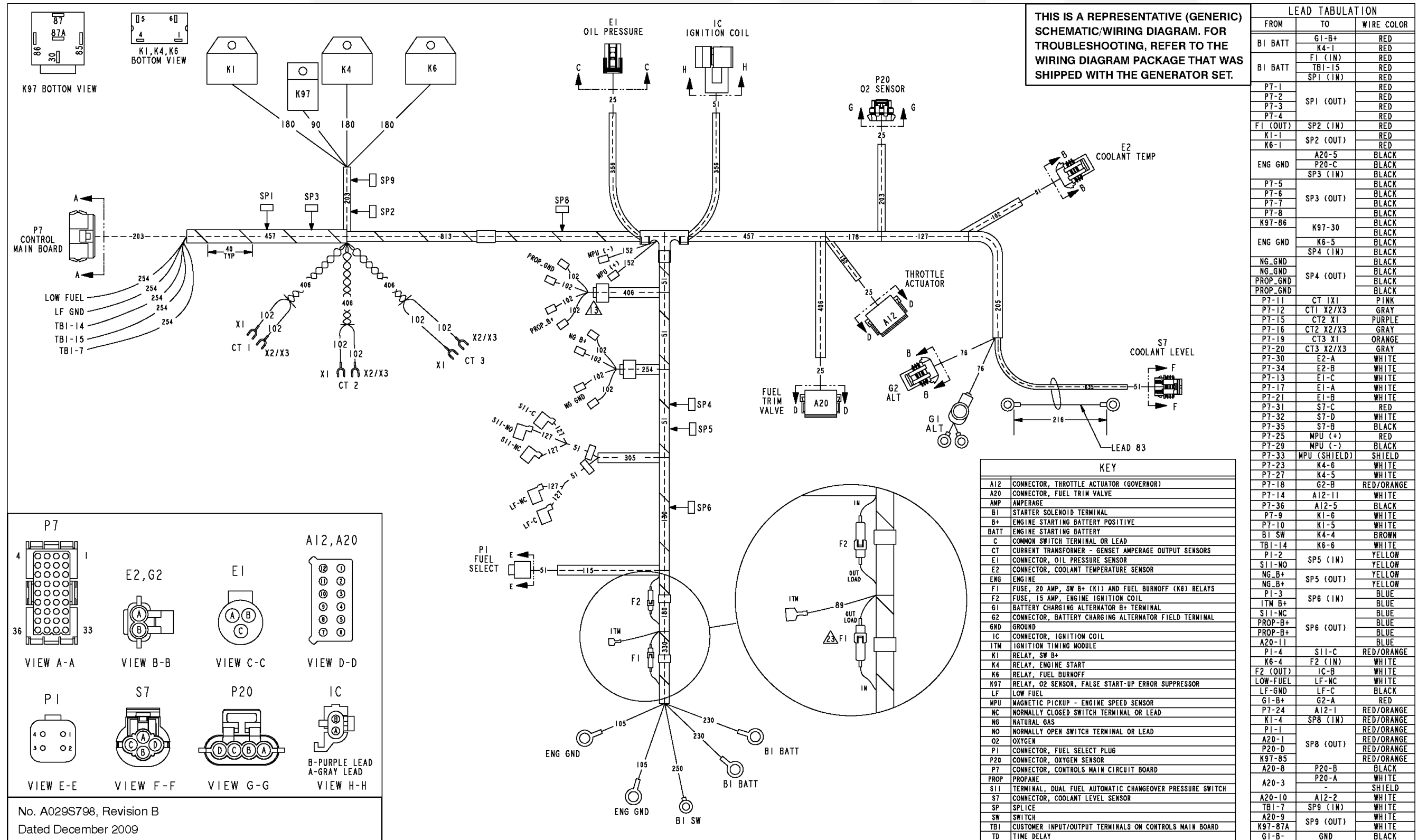
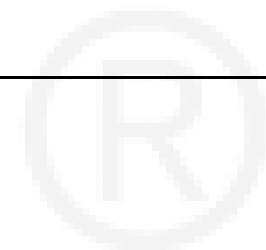

FIGURE 34. GENSET WIRING HARNESS

This page is intentionally blank.



# Appendix C. Outline Drawings

---

## Table of Contents

Figure 35. Outline Drawing (0500-5070) .....	83
Figure 36. Outline Drawing (0500-5030 Sheet 1) .....	84
Figure 37. Outline Drawing (0500-5030 Sheet 2) .....	85
Figure 38. Outline Circuit Breaker (0500-3278 Sheet 1) .....	86
Figure 39. Outline Circuit Breaker (0500-3278 Sheet 2) .....	87
Figure 40. Outline Circuit Breaker (0500-3278 Sheet 3) .....	88
Figure 41. Outline Drawing (0500-4814) .....	89
Figure 42. Outline Drawing (0500-4813 Sheet 1) .....	90
Figure 43. Outline Drawing (0500-4813 Sheet 2) .....	91
Figure 44. Outline Drawing (500-3171) Sheet 1 .....	92
Figure 45. Outline Drawing (500-3171) Sheet 2 .....	93
Figure 46. Outline Drawing (0500-3167) .....	94
Figure 47. Outline Drawing (0500-3211) .....	95

## C.0 Outline Drawings

See the applicable outline drawing in [Appendix C on page 81](#) to check for installation details such as:

- mounting bolt hole locations
- connection points (fuel, battery, raw water, exhaust, remote control, AC output)
- sizes and types of fittings
- overall dimensions

See your Cummins Onan Distributor for large-scale copies of the applicable drawings.

**⚠ WARNING**

***Improper installation can result in severe personal injury, death, and equipment damage. The installer must be qualified to perform installation of electrical and mechanical equipment.***

# C.1 Outline Drawing 0500-5070 (F177)

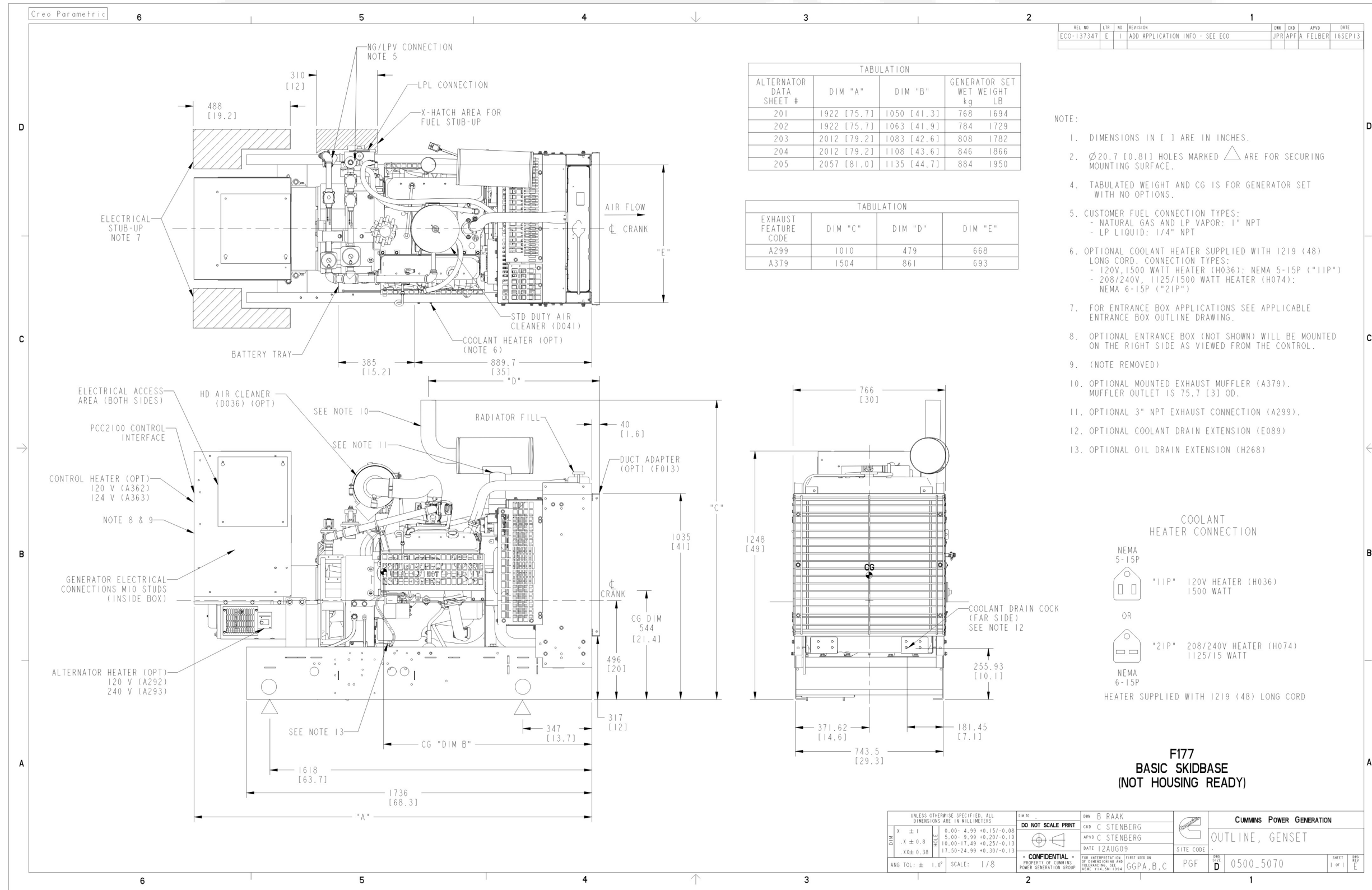

FIGURE 35. OUTLINE DRAWING (0500-5070)



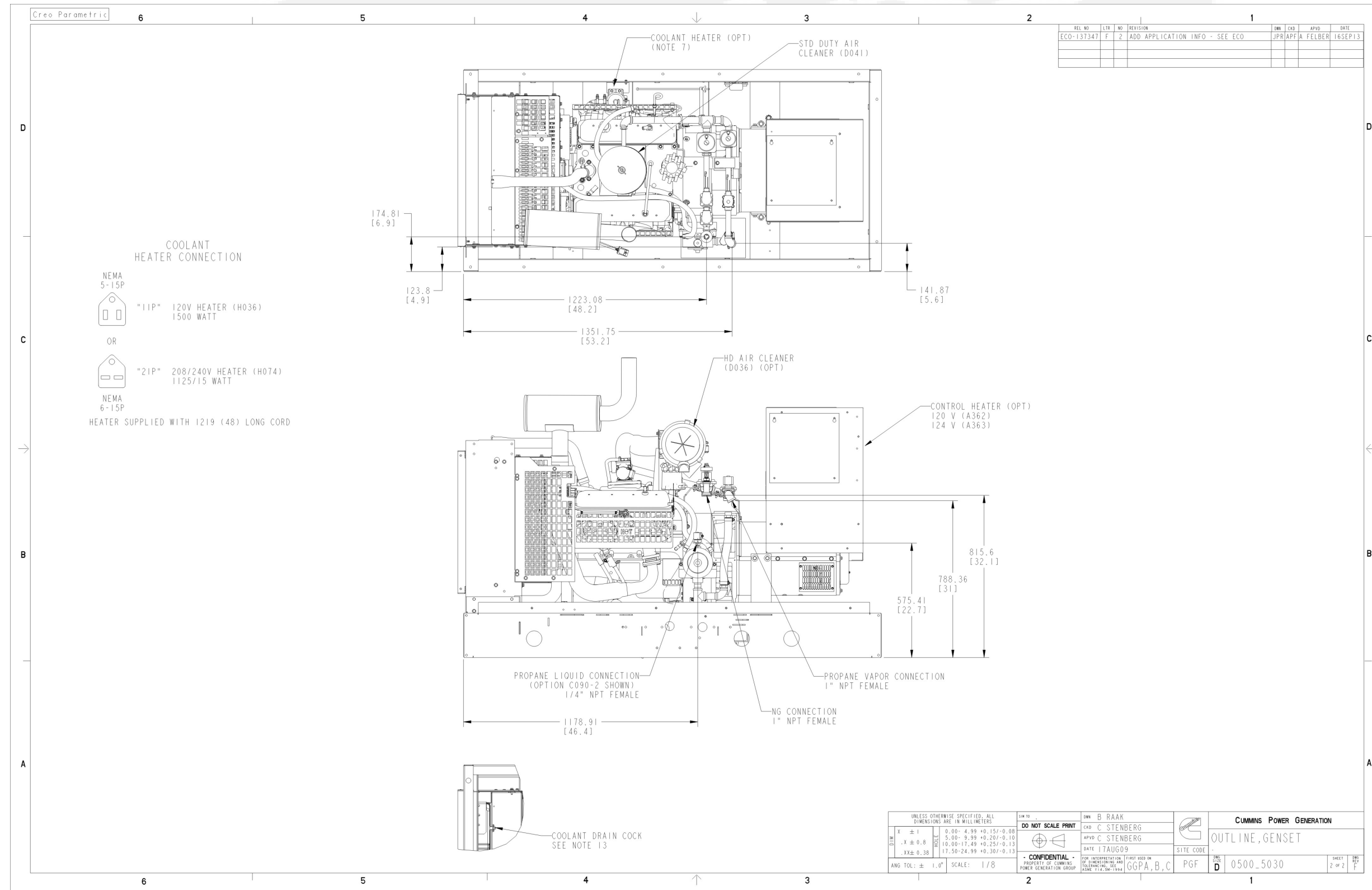

FIGURE 37. OUTLINE DRAWING (0500-5030 SHEET 2)



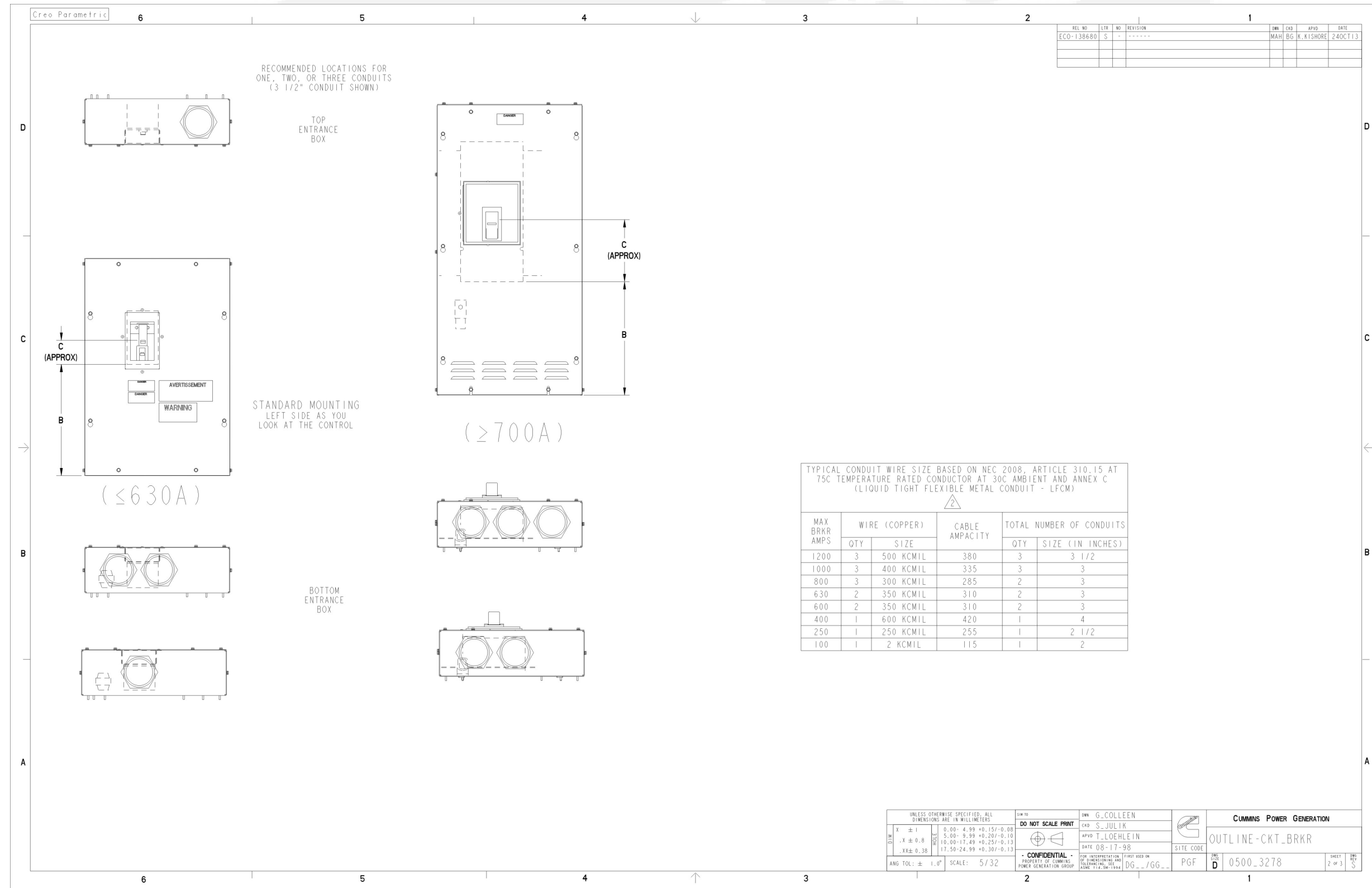

FIGURE 39. OUTLINE CIRCUIT BREAKER (0500-3278 SHEET 2)

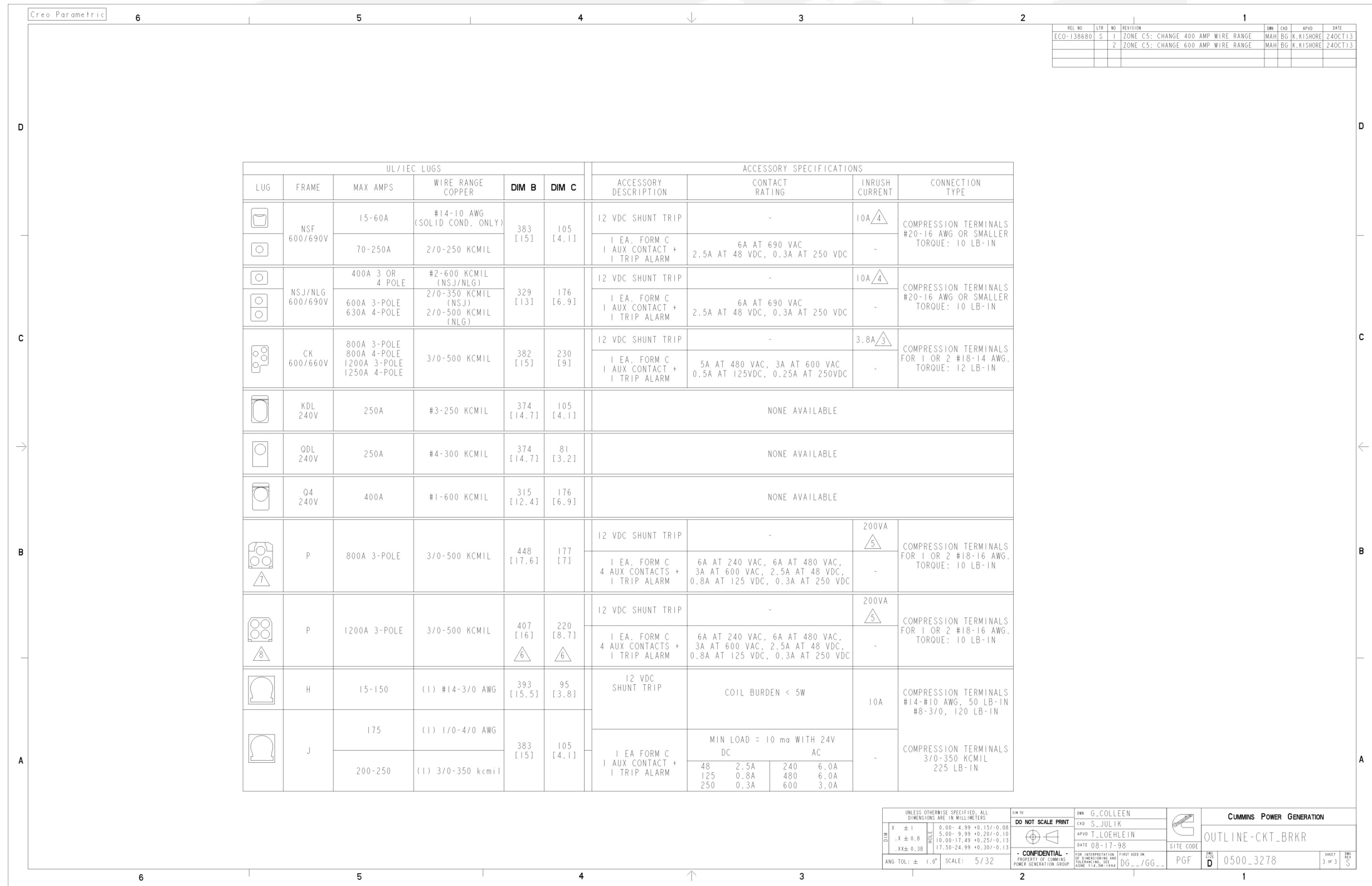

FIGURE 40. OUTLINE CIRCUIT BREAKER (0500-3278 SHEET 3)

### C.4 GGHE/GGHF Enclosure Outline Drawing 0500-4814 (F217)

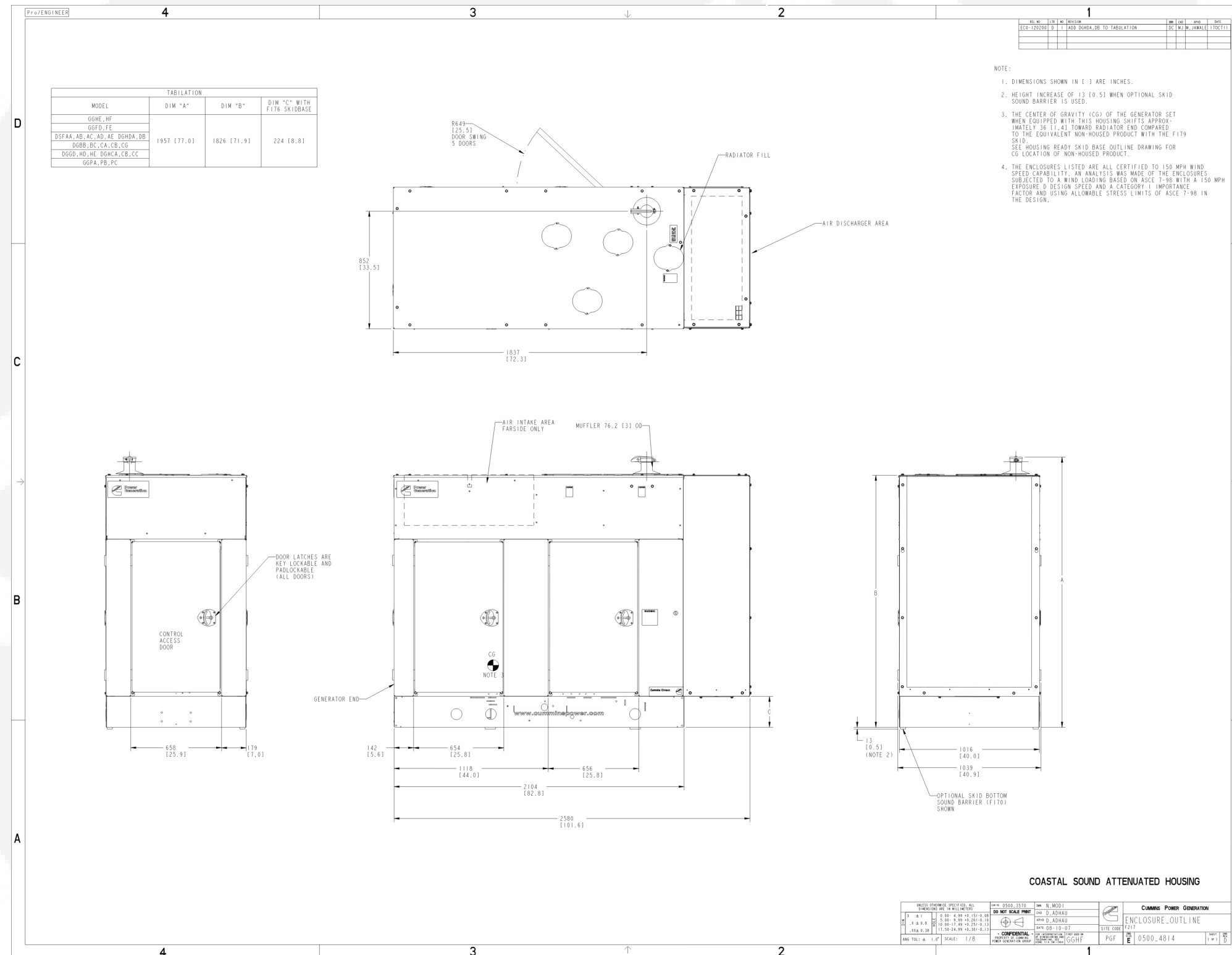

FIGURE 41. OUTLINE DRAWING (0500-4814)

### C.5 GGHE/GGHF Enclosure Outline Drawing 0500-4813 (F216)

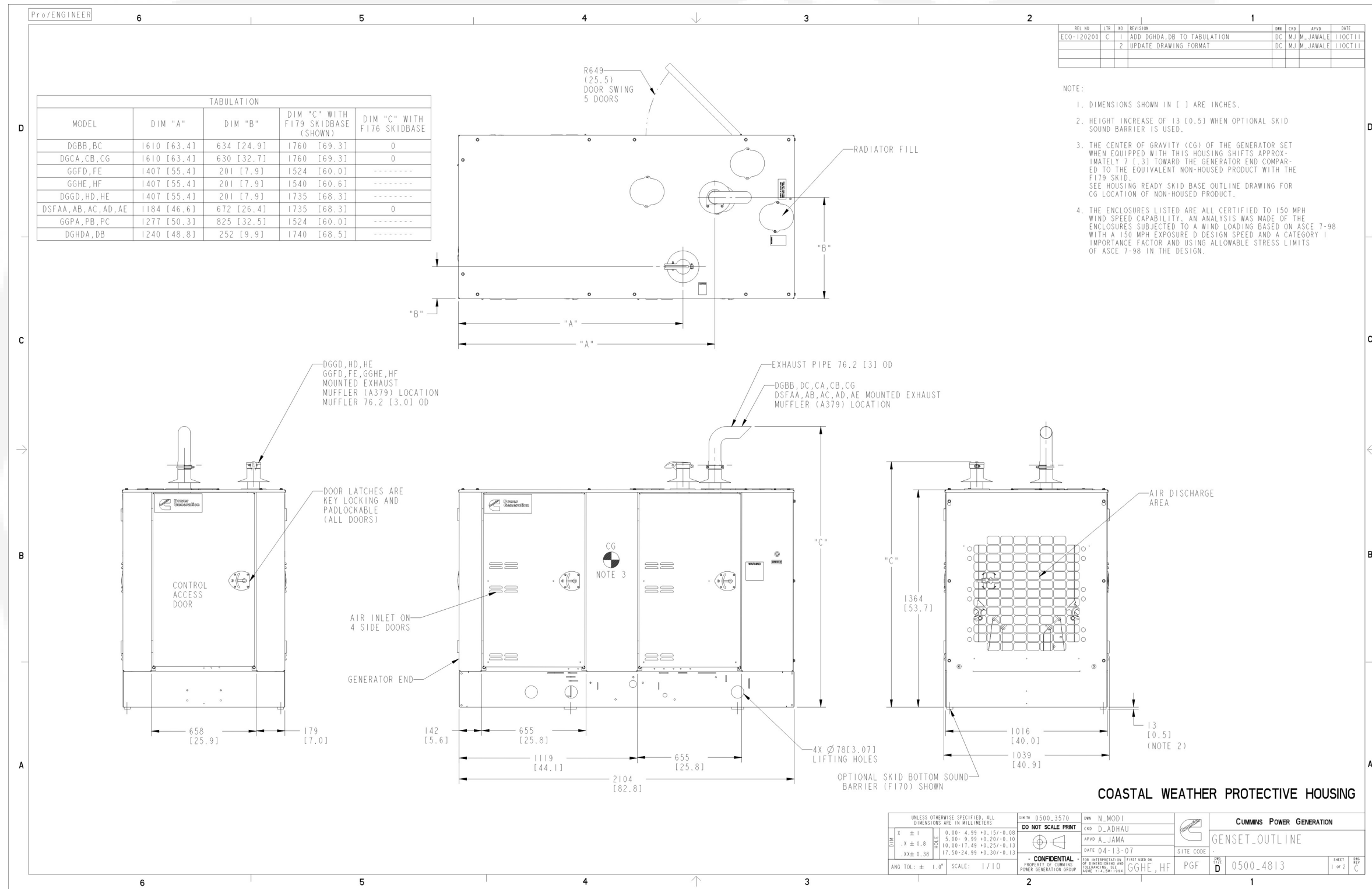

FIGURE 42. OUTLINE DRAWING (0500-4813 SHEET 1)

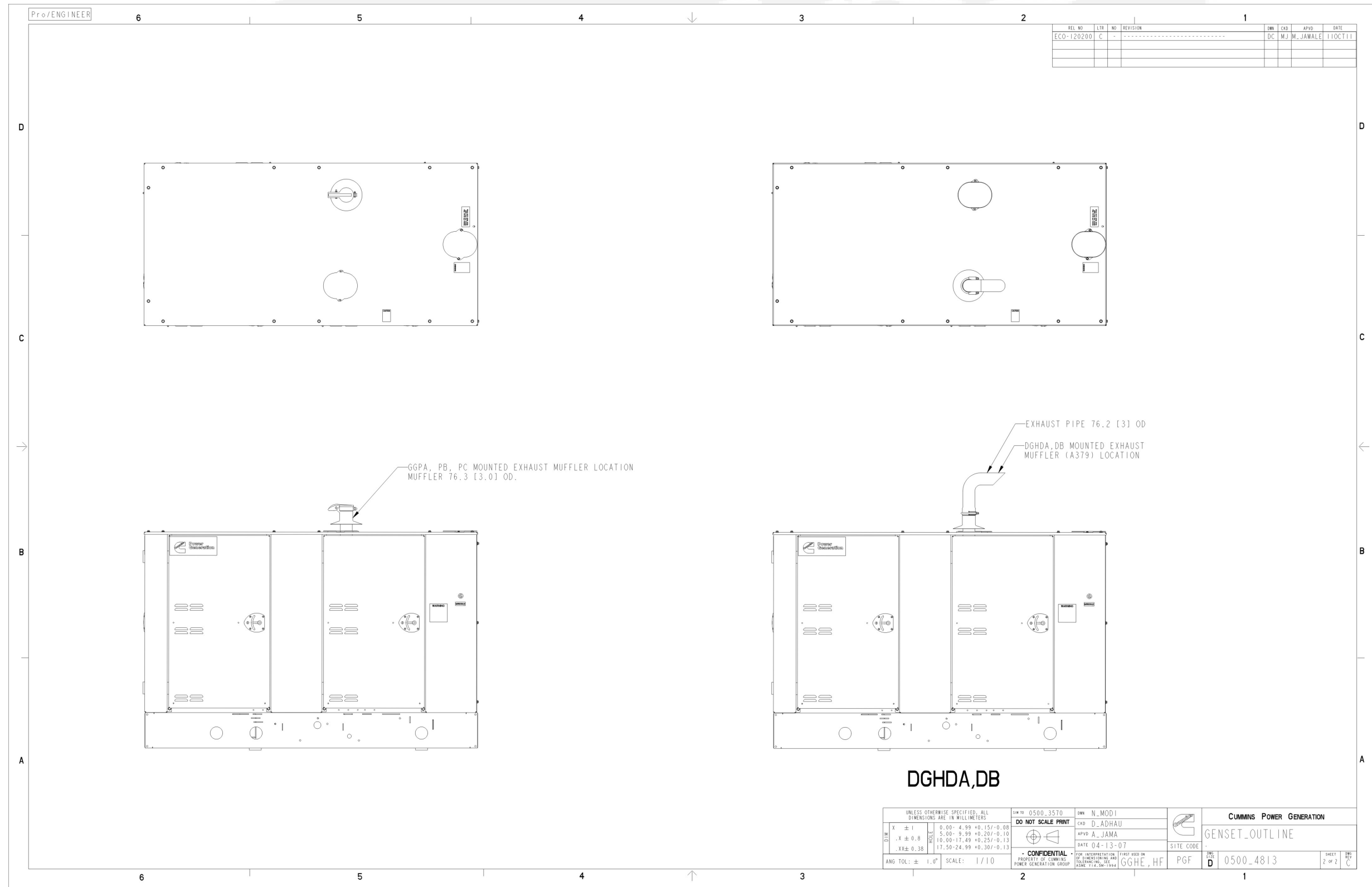

FIGURE 43. OUTLINE DRAWING (0500-4813 SHEET 2)

### C.6 GGHE/GGHF Enclosure Outline Drawing 0500-3171 (F182)

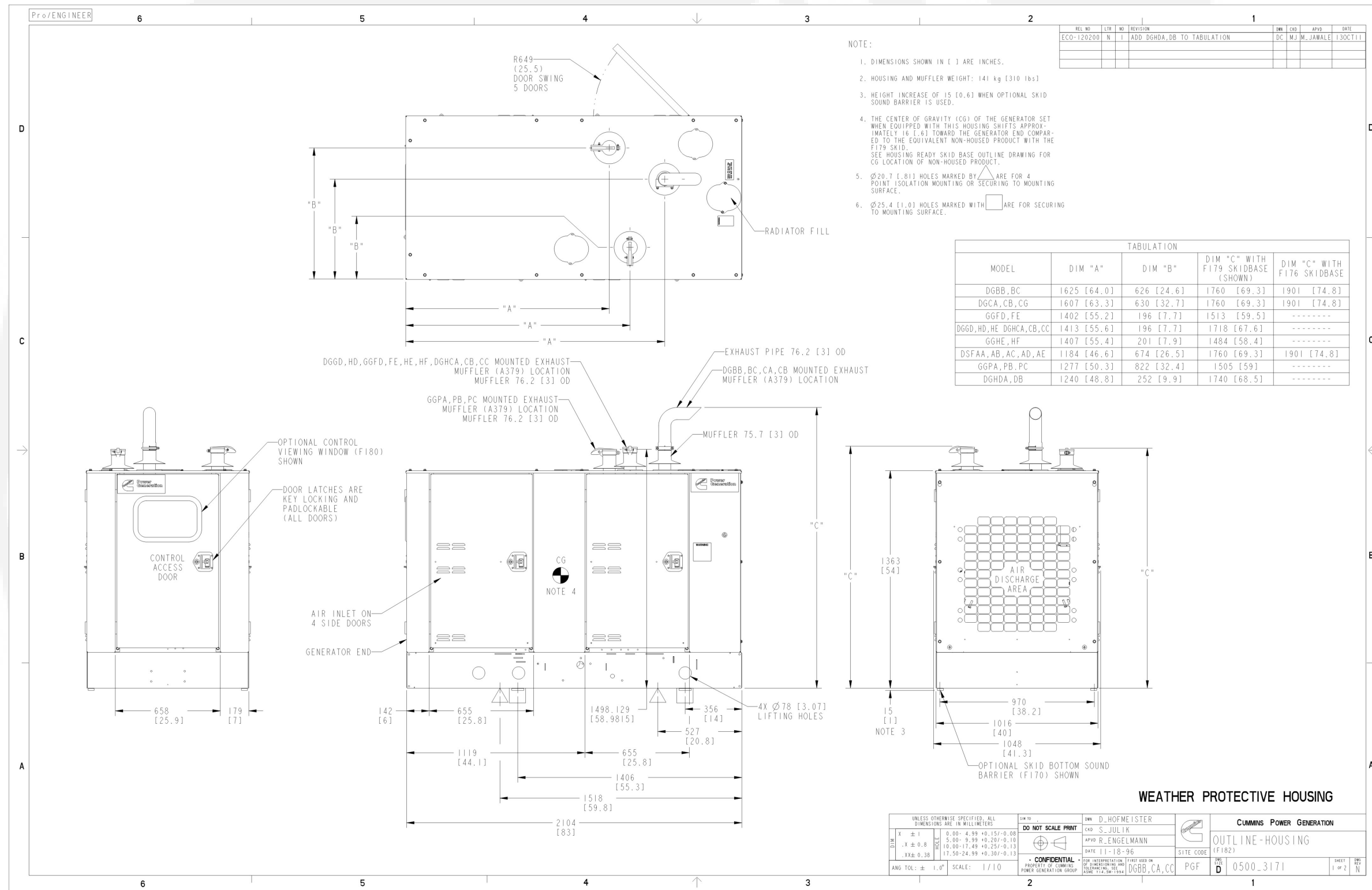

FIGURE 44. OUTLINE DRAWING (500-3171) SHEET 1

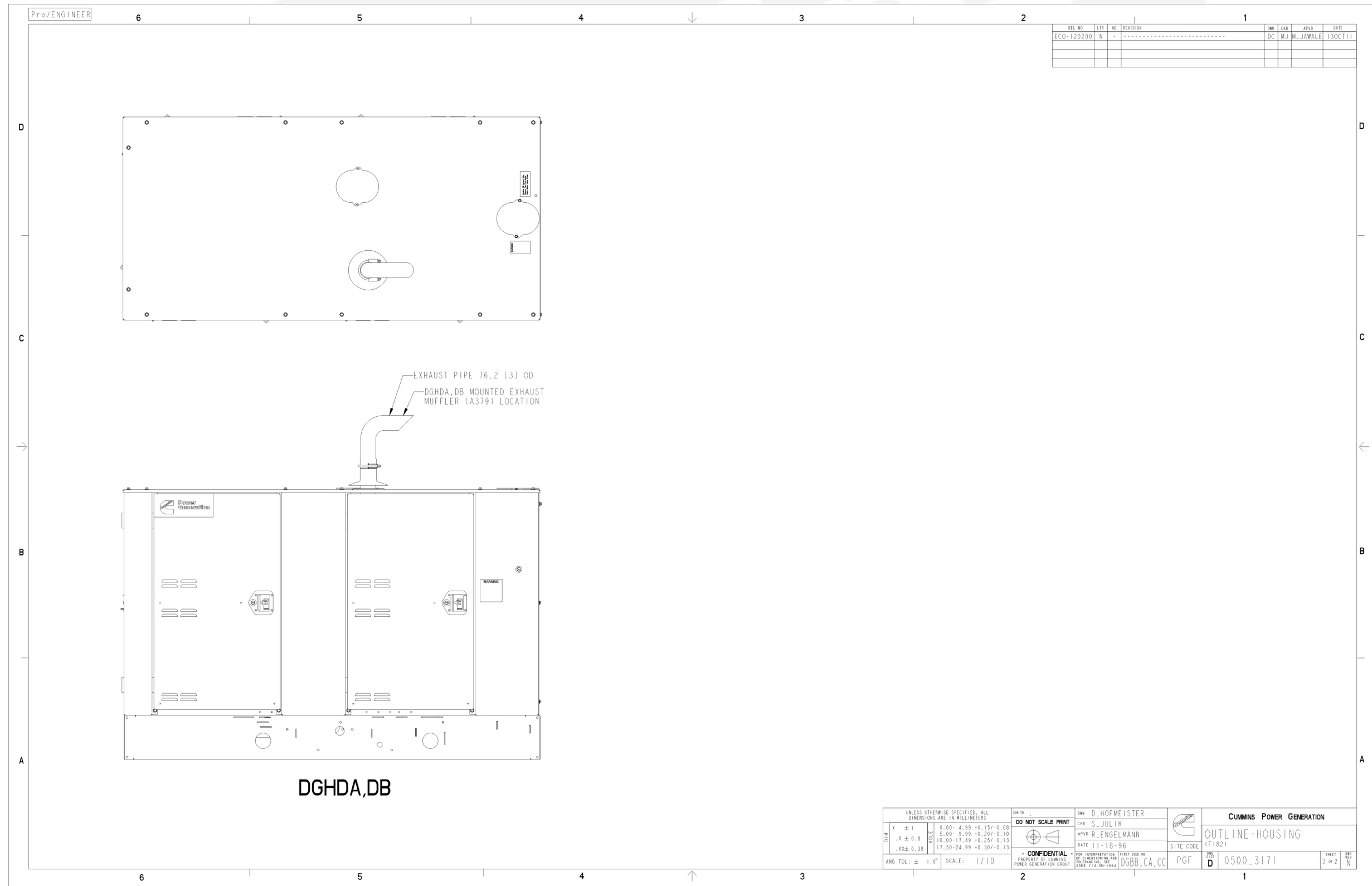
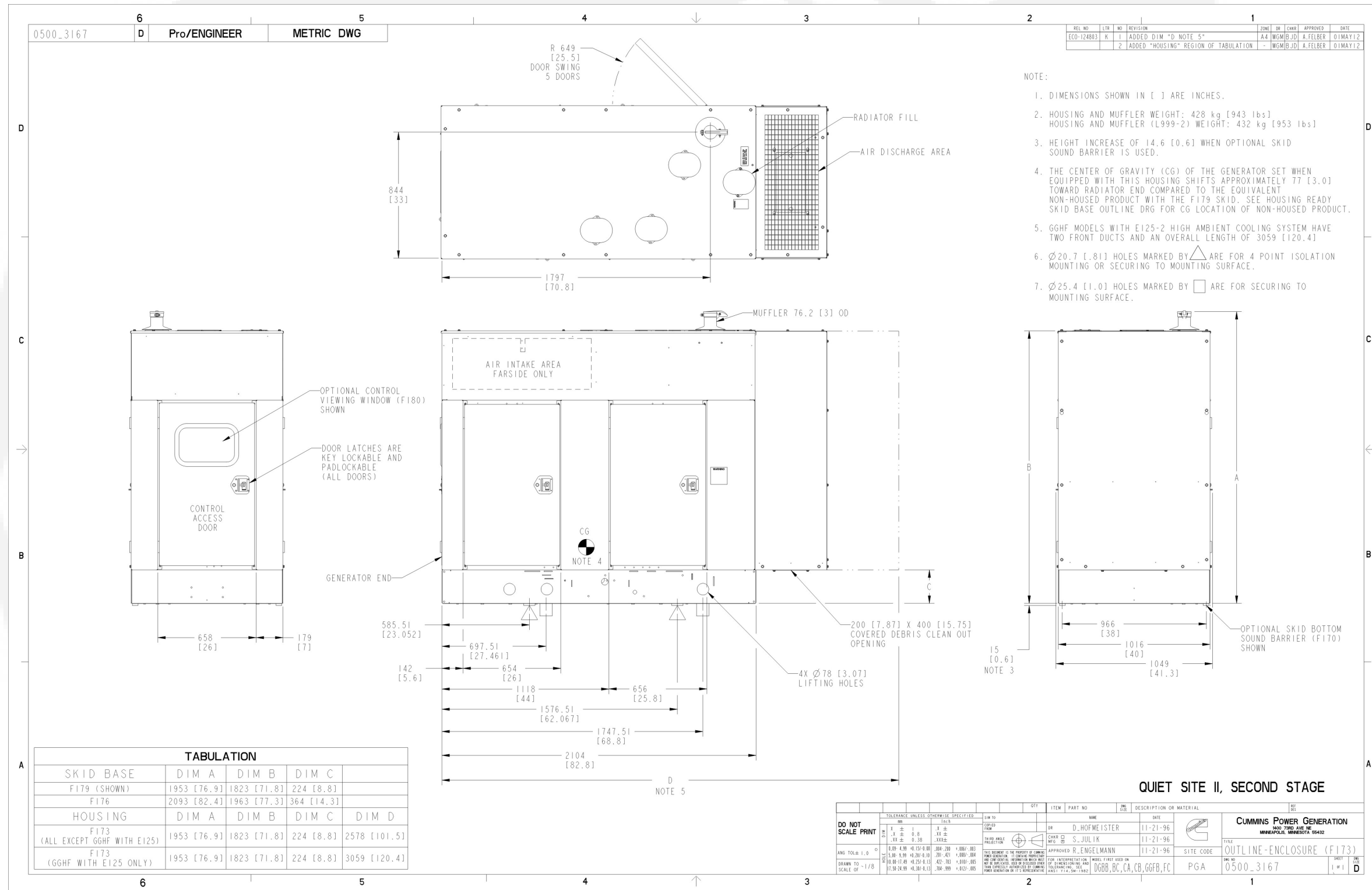

FIGURE 45. OUTLINE DRAWING (500-3171) SHEET 2

### C.7 GGHE/GGHF Enclosure Outline Drawing 0500-3167 (F173)



### C.8 GGHE/GGHF Enclosure Outline Drawing 0500-3211 (F172)

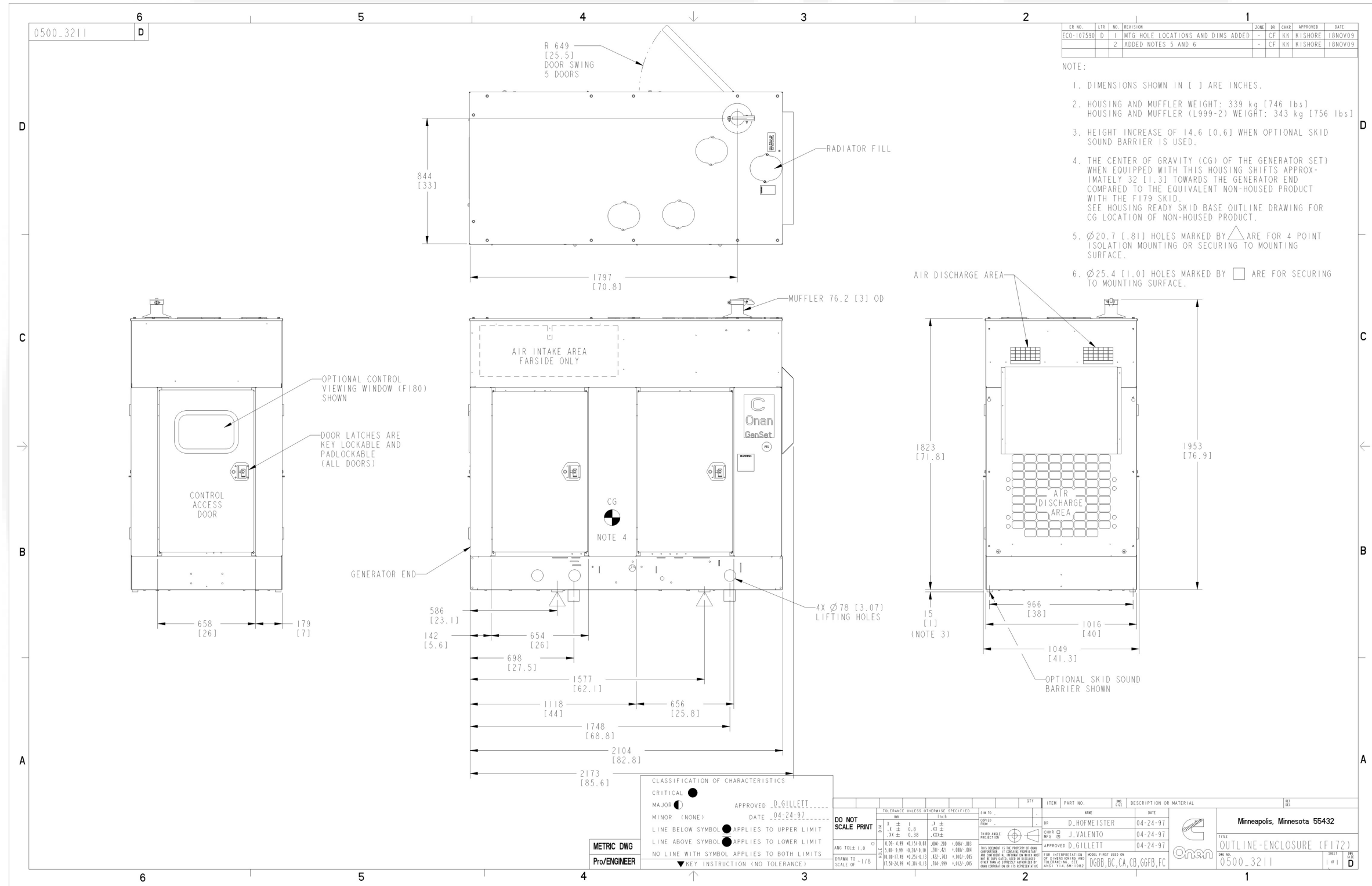
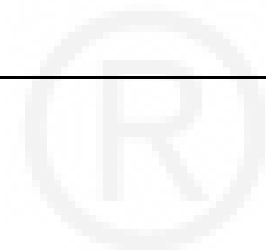

FIGURE 47. OUTLINE DRAWING (0500-3211)



This page is intentionally blank.





[www.cumminspower.com](http://www.cumminspower.com)

Cummins, the "C" logo, and "Our energy working for you." are trademarks of Cummins Inc.

Copyright © 2014 Cummins Power Generation, Inc. All rights reserved.

