

Caution: This document contains mixed page sizes (8.5 x 11 or 11 x 17), which may affect printing. Please adjust your printer settings according to the size of each page you wish to print.



Redistribution or publication of this document by any means, is strictly prohibited.

Service Manual

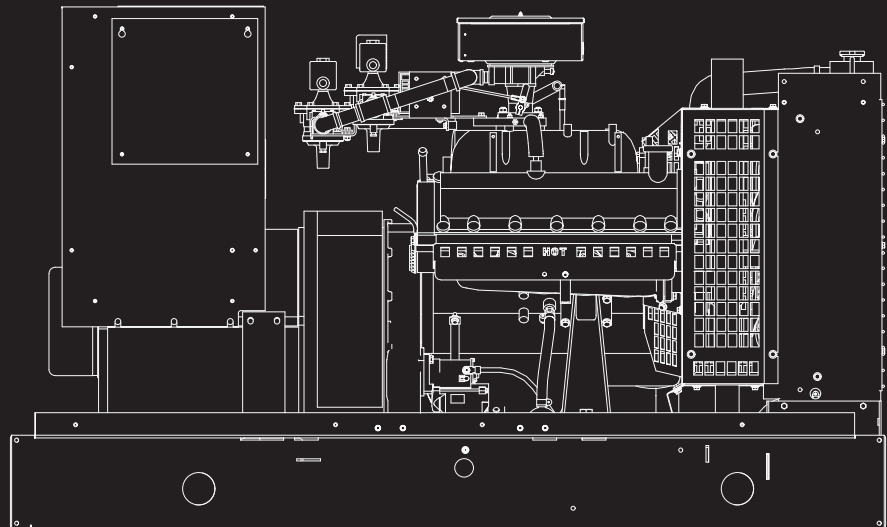

Detector™ Control Generator Sets



Models
GGFD, GGFE, GGHE, GGHF, GGHG, GGHH

Table of Contents

SECTION	TITLE	PAGE
	IMPORTANT SAFETY INSTRUCTIONS	iii
1	INTRODUCTION	
	About This Manual	1-1
	Test Equipment	1-1
	How To Obtain Service	1-1
2	AC CONTROL	
	General	2-1
	AC Control Panel Components	2-1
	Automatic Voltage Regulator (AVR) Adjustments	2-2
	Principle Of Generator Operation	2-7
	UFRO Frequency Adjustment For Turbo Gensets	2-8
3	ENGINE CONTROL	
	General	3-1
	Control Panel Components	3-1
	Control Box Interior	3-3
	Engine Control Monitor (A11)	3-3
	Engine Sensors	3-6
	MAP Sensor (V10 Turbo Only) (Optional)	3-10
	Ignition Control Module (ICM)	3-11
	Auxiliary Control Components	3-12
	Sequence Of Operation	3-15

 **WARNING:** 
The engine exhaust from this product contains chemicals known to the State of California to cause cancer, birth defects or other reproductive harm.

SECTION	TITLE	PAGE
4	TROUBLESHOOTING	
	The Engine Does Not Crank In Run Mode	4-1
	The Engine Does Not Crank In Remote Mode	4-3
	The Engine Cranks But Does Not Start	4-4
	The Engine Runs Until Fault Shutdown	4-7
	The Engine Lacks Power Or Is Unstable	4-10
	An Amber Warning Lamp Is On	4-13
	Low Emissions Genset Only	4-14
	The Green Run Lamp Stays Off But The Set Runs Normally	4-16
	No Output Voltage	4-17
	Output Voltage Is Too High Or Too Low	4-20
	Output Voltage Is Unstable	4-21
	The Field Circuit Breaker Keeps Tripping	4-22
	The Phase Currents Are Unbalanced	4-23
5	SERVICING THE GENERATOR	
	Testing The Generator	5-1
	Removing And Disassembling The Generator	5-9
	Reassembling The Generator	5-11
	Servicing The PMG	5-11
6	GOVERNORS AND FUEL SYSTEMS	
	General	6-1
	Fuel Pressure (Type A & B)	6-1
	Type A Governor/Fuel System Adjustments	6-2
	Type B Governor/Fuel System Adjustments	6-7
	Magnetic Speed Pickup Unit Adjustment	6-9
	Initial Secondary Regulator Adjustment	6-10
	Fuel Conversion (NG to LPV or LPV to NG)	6-11
	Verify Overspeed Fault Detection	6-12
7	WIRING DIAGRAMS	7-1

IMPORTANT SAFETY INSTRUCTIONS

SAVE THESE INSTRUCTIONS – This manual contains important instructions that should be followed during installation and maintenance of the generator and batteries.

Before operating the generator set (genset), read the Operator's Manual and become familiar with it and the equipment. **Safe and efficient operation can be achieved only if the equipment is properly operated and maintained.** Many accidents are caused by failure to follow fundamental rules and precautions.

The following symbols, found throughout this manual, alert you to potentially dangerous conditions to the operator, service personnel, or the equipment.

⚠ DANGER *This symbol warns of immediate hazards which will result in severe personal injury or death.*

⚠ WARNING *This symbol refers to a hazard or unsafe practice which can result in severe personal injury or death.*

⚠ CAUTION *This symbol refers to a hazard or unsafe practice which can result in personal injury or product or property damage.*

FUEL AND FUMES ARE FLAMMABLE

Fire, explosion, and personal injury or death can result from improper practices.

- DO NOT fill fuel tanks while engine is running, unless tanks are outside the engine compartment. Fuel contact with hot engine or exhaust is a potential fire hazard.
- DO NOT permit any flame, cigarette, pilot light, spark, arcing equipment, or other ignition source near the generator set or fuel tank.
- Fuel lines must be adequately secured and free of leaks. Fuel connection at the engine should be made with an approved flexible line. Do not use copper piping on flexible lines as copper will become brittle if continuously vibrated or repeatedly bent.
- Natural gas is lighter than air, and will tend to gather under hoods. Propane is heavier than air, and will

tend to gather in sumps or low areas. NFPA code requires all persons handling propane to be trained and qualified.

- Be sure all fuel supplies have a positive shutoff valve.
- Be sure battery area has been well-ventilated prior to servicing near it. Lead-acid batteries emit a highly explosive hydrogen gas that can be ignited by arcing, sparking, smoking, etc.

EXHAUST GASES ARE DEADLY

- Provide an adequate exhaust system to properly expel discharged gases away from enclosed or sheltered areas and areas where individuals are likely to congregate. Visually and audibly inspect the exhaust daily for leaks per the maintenance schedule. Make sure that exhaust manifolds are secured and not warped. Do not use exhaust gases to heat a compartment.
- Be sure the unit is well ventilated.
- Engine exhaust and some of its constituents are known to the state of California to cause cancer, birth defects, and other reproductive harm.

MOVING PARTS CAN CAUSE SEVERE PERSONAL INJURY OR DEATH

- Keep your hands, clothing, and jewelry away from moving parts.
- Before starting work on the generator set, disconnect battery charger from its AC source, then disconnect starting batteries, negative (-) cable first. This will prevent accidental starting.
- Make sure that fasteners on the generator set are secure. Tighten supports and clamps, keep guards in position over fans, drive belts, etc.
- Do not wear loose clothing or jewelry in the vicinity of moving parts, or while working on electrical equipment. Loose clothing and jewelry can become caught in moving parts. Jewelry can short out electrical contacts and cause shock or burning.
- If adjustment must be made while the unit is running, use extreme caution around hot manifolds, moving parts, etc.

ELECTRICAL SHOCK CAN CAUSE SEVERE PERSONAL INJURY OR DEATH

- Remove electric power before removing protective shields or touching electrical equipment. Use rubber insulative mats placed on dry wood platforms over floors that are metal or concrete when around electrical equipment. Do not wear damp clothing (particularly wet shoes) or allow skin surface to be damp when handling electrical equipment.
- Use extreme caution when working on electrical components. High voltages can cause injury or death. **DO NOT** tamper with interlocks.
- Follow all applicable state and local electrical codes. Have all electrical installations performed by a qualified licensed electrician. Tag and lock open switches to avoid accidental closure.
- **DO NOT CONNECT GENERATOR SET DIRECTLY TO ANY BUILDING ELECTRICAL SYSTEM.** Hazardous voltages can flow from the generator set into the utility line. This creates a potential for electrocution or property damage. Connect only through an approved isolation switch or an approved paralleling device.

GENERAL SAFETY PRECAUTIONS

- Coolants under pressure have a higher boiling point than water. **DO NOT** open a radiator or heat exchanger pressure cap while the engine is running. Allow the generator set to cool and bleed the system pressure first.
- Benzene and lead, found in some gasoline, have been identified by some state and federal agencies as causing cancer or reproductive toxicity. When checking, draining or adding gasoline, take care not to ingest, breathe the fumes, or contact gasoline.
- Used engine oils have been identified by some state or federal agencies as causing cancer or reproductive toxicity. When checking or changing engine oil, take care not to ingest, breathe the fumes, or contact used oil.
- Keep multi-class ABC fire extinguishers handy. Class A fires involve ordinary combustible materials such as wood and cloth; Class B fires, combustible and flammable liquid fuels and gaseous fuels; Class C fires, live electrical equipment. (ref. NFPA No. 10).
- Make sure that rags are not left on or near the engine.
- Make sure generator set is mounted in a manner to prevent combustible materials from accumulating under the unit.
- Remove all unnecessary grease and oil from the unit. Accumulated grease and oil can cause overheating and engine damage which present a potential fire hazard.
- Keep the generator set and the surrounding area clean and free from obstructions. Remove any debris from the set and keep the floor clean and dry.
- Do not work on this equipment when mentally or physically fatigued, or after consuming any alcohol or drug that makes the operation of equipment unsafe.
- Substances in exhaust gases have been identified by some state or federal agencies as causing cancer or reproductive toxicity. Take care not to breathe or ingest or come into contact with exhaust gases.
- Do not store any flammable liquids, such as fuel, cleaners, oil, etc., near the generator set. A fire or explosion could result.
- Wear hearing protection when going near an operating generator set.
- To prevent serious burns, avoid contact with hot metal parts such as radiator, turbo charger and exhaust system.

KEEP THIS MANUAL NEAR THE GENSET FOR EASY REFERENCE

1. Introduction

ABOUT THIS MANUAL

This manual covers models produced under the Cummins®/Onan® and Cummins Power Generation brand names.

This manual provides troubleshooting and repair information regarding the Detector™ Control and generators for the generator set models listed on the front cover. Engine service instructions are in the applicable engine service manual. Operating and maintenance instructions are in the applicable Operator's Manual.

This manual does not have instructions for servicing printed circuit board assemblies. Always replace a faulty printed circuit board assembly. Attempts to repair a printed circuit board can lead to costly damage to the equipment.

This manual contains basic (generic) wiring diagrams and schematics that are included to help in troubleshooting. **Service personnel must use the actual wiring diagram and schematic shipped with each unit.** The wiring diagrams and schematics that are maintained with the unit should be updated when modifications are made to the unit.

Read **Safety Precautions** and carefully observe all instructions and precautions in this manual.

TEST EQUIPMENT

Most of the tests in this manual can be done with an AC-DC multimeter, frequency meter, Wheatstone bridge (0.001 ohm precision is necessary for measuring stator winding resistance) and load test panel.

HOW TO OBTAIN SERVICE

Always give the complete Model, Specification and Serial number of the generator set as shown on the nameplate when seeking additional service information or replacement parts. The nameplate is located on the side of the generator output box.

For replacement parts identification, refer to the Parts Manual supplied with the generator set.

⚠WARNING *Incorrect service or replacement of parts can result in severe personal injury or death, and/or equipment damage. Service personnel must be trained and experienced to perform electrical and mechanical service. Read and follow Safety Precautions, on pages iii and iv.*

Copyright© 2001 Cummins Power Generation. All rights reserved.
Cummins and Onan are registered trademarks of Cummins Inc.
Detector is a trademark of Cummins Inc.

THIS PAGE LEFT INTENTIONALLY BLANK

2. AC Control

GENERAL

The control box is mounted on top of the generator, facing the rear. Figure 2-1 points out the components on the AC control panel. Refer to *Section 7* for the AC control wiring diagrams.

AC CONTROL PANEL COMPONENTS

Field Circuit Breaker (CB21) The field circuit breaker protects the generator from over-excitation.

AC Voltmeter (M21) The voltmeter indicates output voltage for the phase selected.

AC Ammeter (M22) The ammeter indicates output amperage for the phase selected. Input to the am-

meter is from current transformers CT21, CT22, and CT23.

Phase Selector Switch (S21) The selector switch is used to select the phase for voltage and amperage readings.

Scale Indicator Lamps (DS21 and DS22) The scale indicator lamps indicate whether to read the upper or lower scales of the voltmeter and ammeter.

Frequency Meter (M23) The frequency meter indicates output frequency in Hertz (Hz) and engine speed in RPM.

Output Voltage Trimmer (R21) The output voltage trimmer can be used to adjust output voltage plus or minus five percent of nominal voltage.

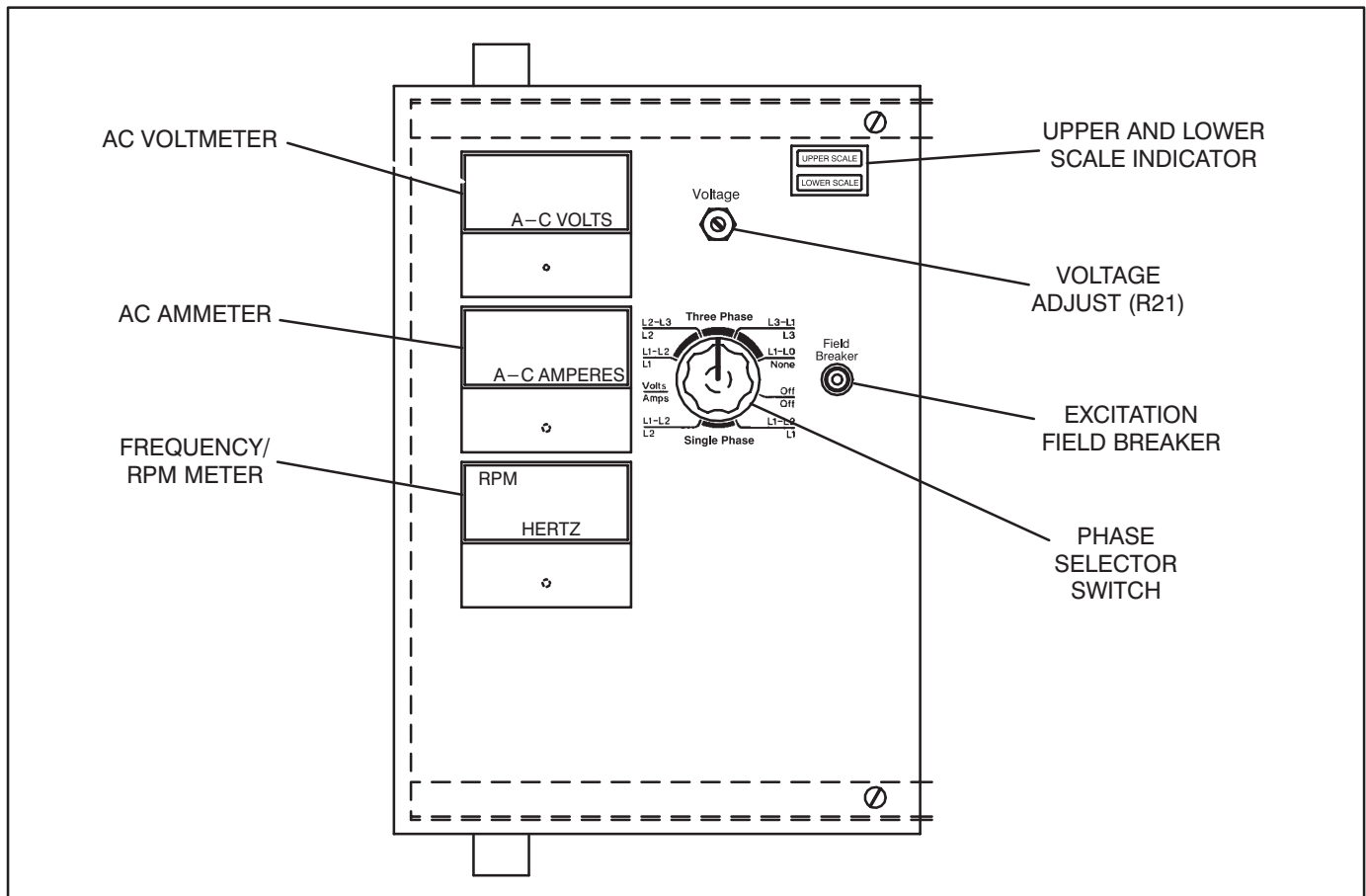

FIGURE 2-1. AC CONTROL PANEL

AUTOMATIC VOLTAGE REGULATOR (AVR) ADJUSTMENTS

The automatic voltage regulator (AVR) is mounted inside of the control cabinet. The location of the AVR is shown in Figure 2-2.

Two AVR's are available – MX321 and SX460. The AVR's are adjusted by means of the potentiometers (pots) shown in Figures 2-3 and 2-4. Differences in adjustments are noted in the following control descriptions. Figures 2-5 (MX321) and 2-7 (SX460) show typical voltage regulating circuits.

These measurements and adjustments are done while the set is running and require access to uninsulated high voltage parts in the control and power output boxes.

⚠ WARNING HAZARDOUS VOLTAGE. *Touching uninsulated parts inside the control housing and power output boxes can result in severe personal injury or death. Measurements and adjustments must be done with care to avoid touching hazardous voltage parts.*

Stand on a dry wooden platform or rubber insulating mat, make sure your clothing and shoes are dry, remove jewelry and use tools with insulated handles.

Jumper Reconnections (MX321 only)

Jumpers provide for reconnections to adapt the AVR to the application. See Figure 2-3. With the generator set shut down, reconnect the following jumpers, if necessary, to correspond to the operating characteristics of the generator set.

- **Jumper 1–2–3 or 60-C-50:**
Jumper 1 – 3 or 60 – C: Selects 60Hz
Jumper 2 – 3 or 50 – C: Selects 50Hz
- **Jumper A–B–C:**
Jumper A – C: Selects 90 kW or less and 50 Hz/75 kW GGHH
Jumper B – C: Selects greater than 90 kW but less than 550 kW and 60 Hz/85 kW GGHG
Jumper A – B: Selects greater than 550 kW and 60 Hz/100kW GGHH

Jumper Reconnections (SX460 only)

Jumpers provide for reconnections to adapt the AVR to the application. See Figure 2-4. With the generator set shut down, reconnect the following jumpers, if necessary, to correspond to the operating characteristics of the generator set.

- **Jumper 60–C–50:**
Jumper 60 – C: Selects 60Hz
Jumper 50 – C: Selects 50Hz
- **Jumper 1 – 2:**
Jumper installed – Without output voltage trimmer (R21)
Jumper removed – With output voltage trimmer (R21)
- **Jumper 3 – 4:**
Jumper installed – Selects 110/120V sensing voltage input (not used)
Jumper removed – Selects 240V sensing voltage input (standard)

Voltage and Voltage Stability Adjustments (MX321 and SX460)

Use the control panel mounted voltage trimmer, if provided, for small voltage adjustments. Measure generator output voltage while the set is running without load at the nominal frequency. If the trimmer does not provide enough adjustment, lock it at its midpoint. Then turn the **VOLTS** pot fully counterclockwise and the **STABILITY** pot to its midpoint. If the red LED (light emitting diode) on the board lights, refer to Jumper Reconnections and to UFRO Adjustments. Then turn the **VOLTS** pot clockwise until rated voltage is obtained. If voltage becomes unstable when a large load is connected, turn the **STABILITY** pot clockwise until voltage is stable. Check and readjust the **VOLTS** pot, if necessary, each time the **STABILITY** pot is readjusted.

UFRO Adjustments (MX321 and SX460)

The voltage regulator has an under-frequency protection circuit having a threshold frequency that can be preset. For naturally aspirated fuel systems it is typically 59 Hz for 60 Hz applications and 49 Hz for 50 Hz applications. For turbo fuel systems it is typically 59.5 Hz for 60 Hz applications and 49.5 Hz for 50 Hz applications.

The red LED on the board lights when frequency dips below the threshold. Determine threshold frequency by lowering generator frequency until the LED lights.

To lower the frequency for naturally aspirated gensets, the Speed Trim pot of the governor controller is used (refer to *Section 6*). For turbo gensets, two leads which are located in the engine harness must be connected to lower the genset frequency by 0.5 hertz (refer to *UFRO Frequency Adjustment for Turbo Gensets* in this section).

If adjustment is required, pre-set the UFRO by adjusting the generator to the frequency as noted above. Turn UFRO pot clockwise until the LED is lit, then counterclockwise until the LED is off. Set UFRO pot by turning the pot slowly clockwise until the LED just lights.

Note that Dip and Dwell adjustments are related.

Dip Adjustments (MX321 only)

The **DIP** pot adjusts the voltage vs. frequency slope of the generator for frequencies below the threshold preset by the **UFRO** pot. Turning the **DIP** pot clockwise increases the slope (for greater voltage roll off

as frequency drops), making it easier for the engine to pick up a large load, but also increasing the voltage dip. The generator voltage vs. frequency slope is the same above and below the threshold frequency when the pot is turned fully counterclockwise. For 60Hz generator sets, adjust voltage dip pot fully counter clockwise.

Dwell Adjustments (MX321 only)

The **DWELL** pot adjusts voltage recovery time when frequency dips below the preset threshold. Clockwise adjustment increases dwell time. Full counterclockwise adjustment eliminates dwell, in which case, voltage recovery follows engine speed recovery.

Droop Adjustments (MX321 only)

The **DROOP** pot is for adjusting the input signal from the droop compensating CT in paralleling applications. **DROOP** is preset at the factory for five percent droop at full load and zero power factor.

V / Trim Adjustments (MX321 only)

The **V / Trim** (MX321) or **Trim** (SX421) pot is for adjusting the input signal from a VAR / PF controller in utility paralleling applications. Full clockwise adjustment is normal, resulting in maximum sensitivity. The auxiliary controller has no effect when the pot is turned fully counterclockwise.

EXC, OVER V, I / LIMIT, STAB/1 and RMS (MX321 only)

These pots are factory preset and do not require adjustment.

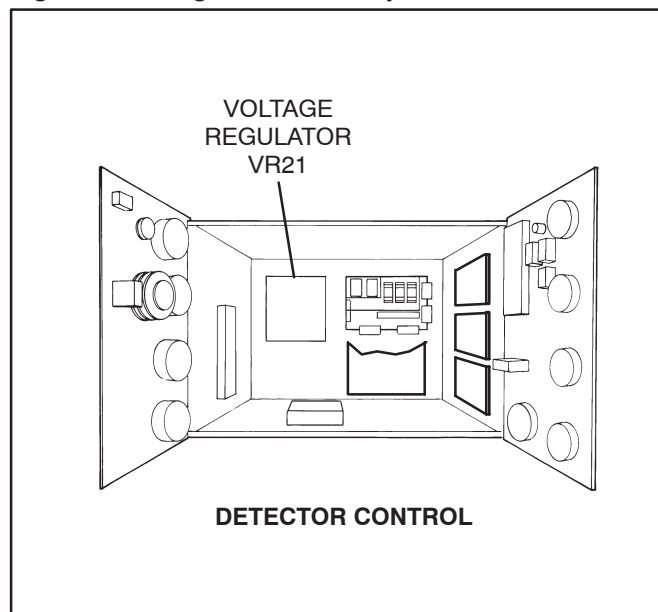

FIGURE 2-2. VOLTAGE REGULATOR LOCATION

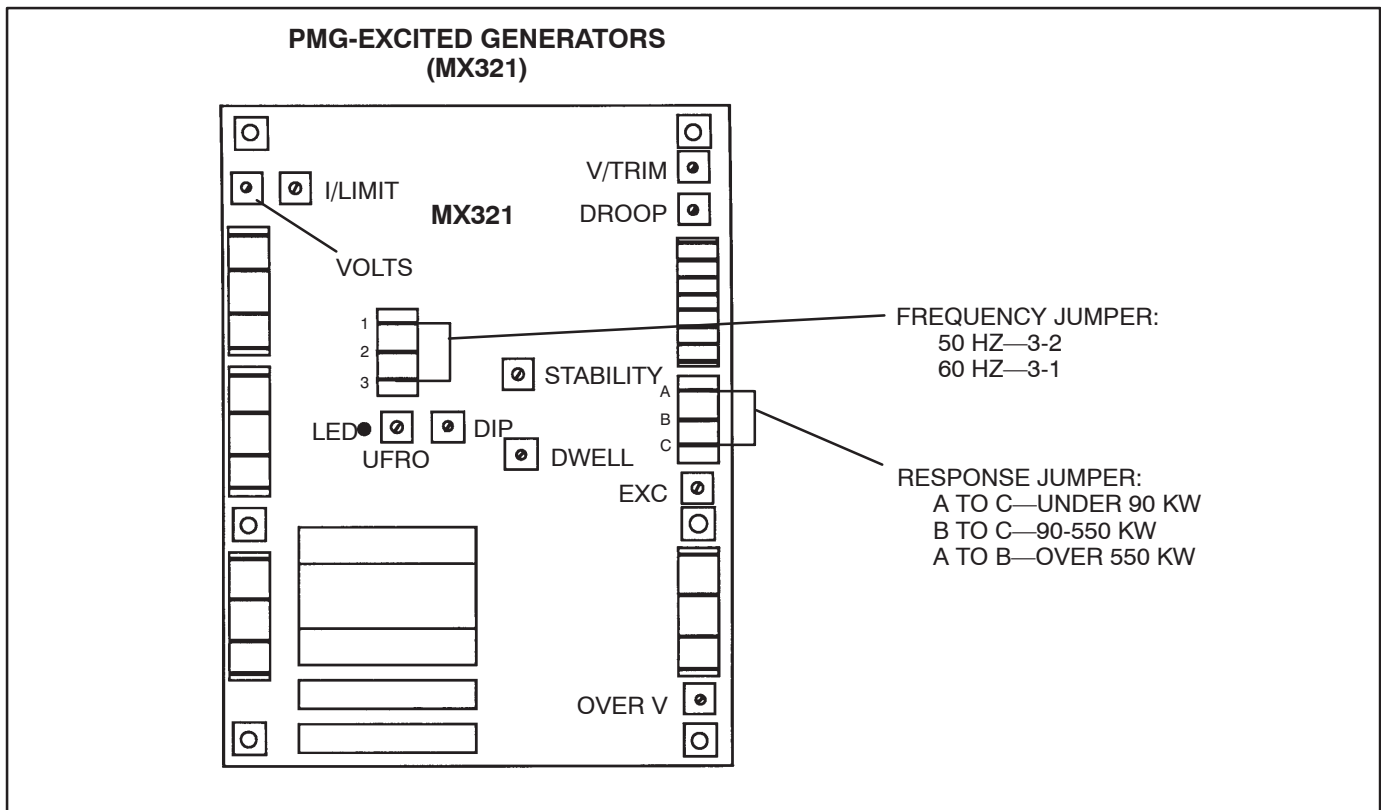

FIGURE 2-3. VOLTAGE REGULATOR ADJUSTMENT POTS AND SELECTION JUMPERS (MX321)

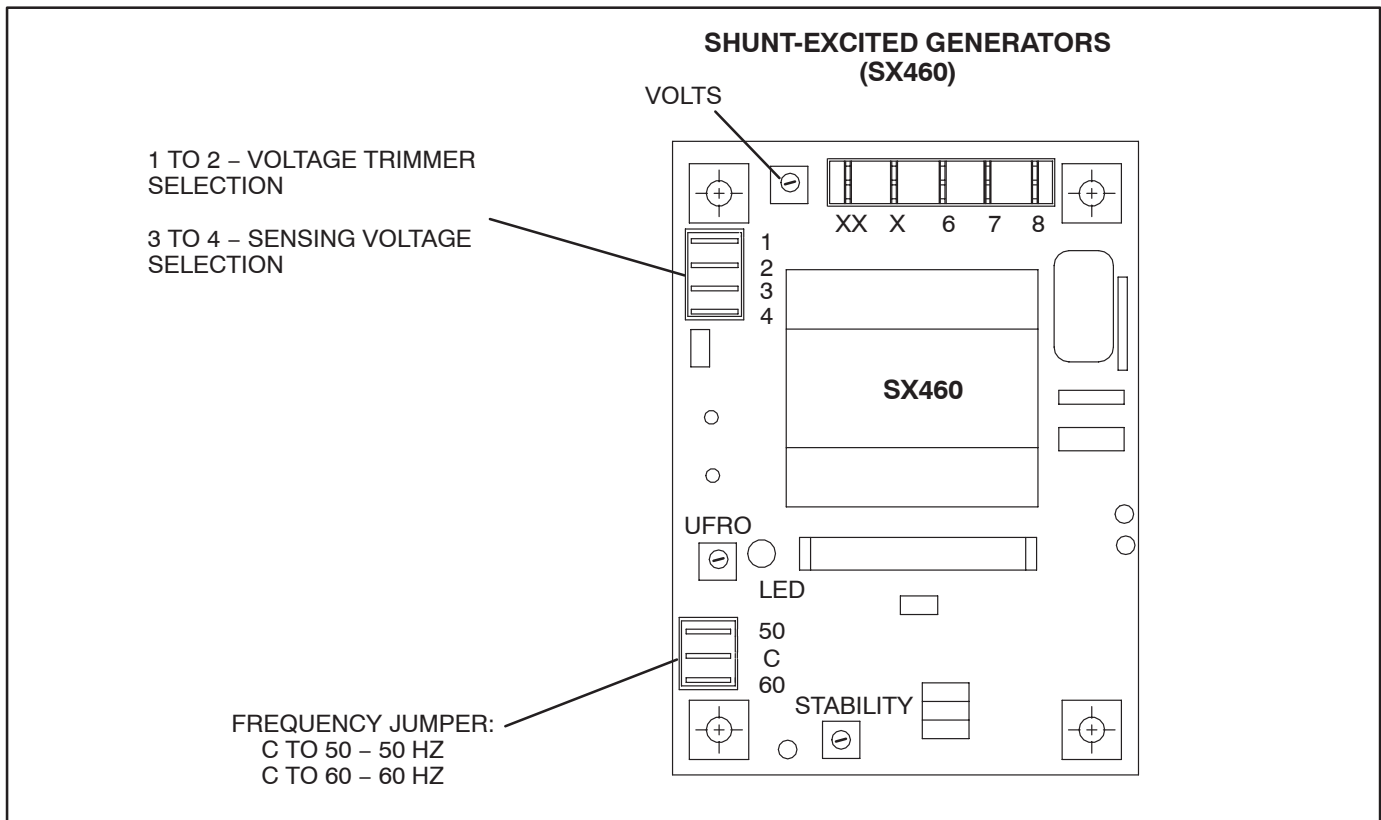

FIGURE 2-4. VOLTAGE REGULATOR ADJUSTMENT POTS AND SELECTION JUMPERS (SX460)

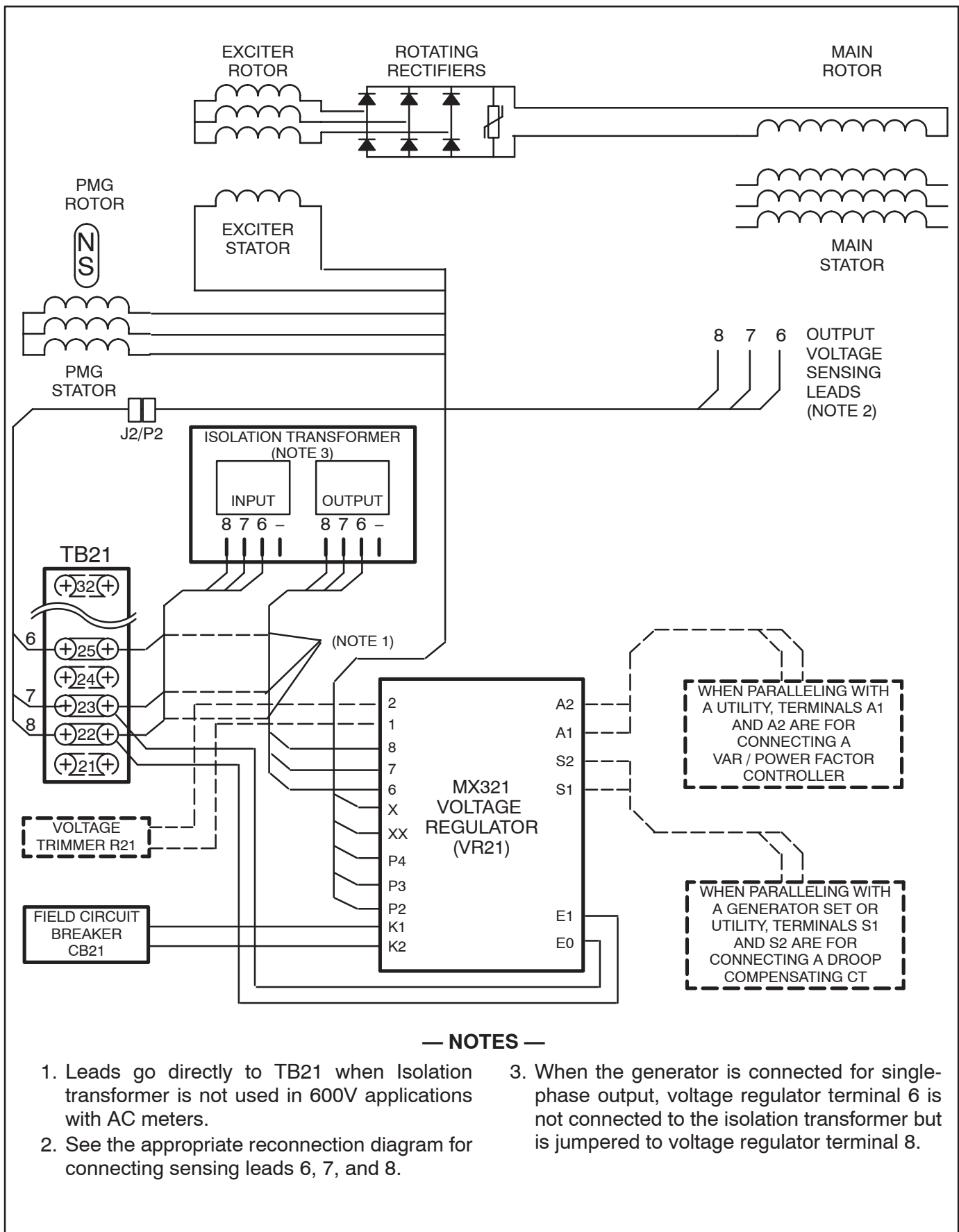
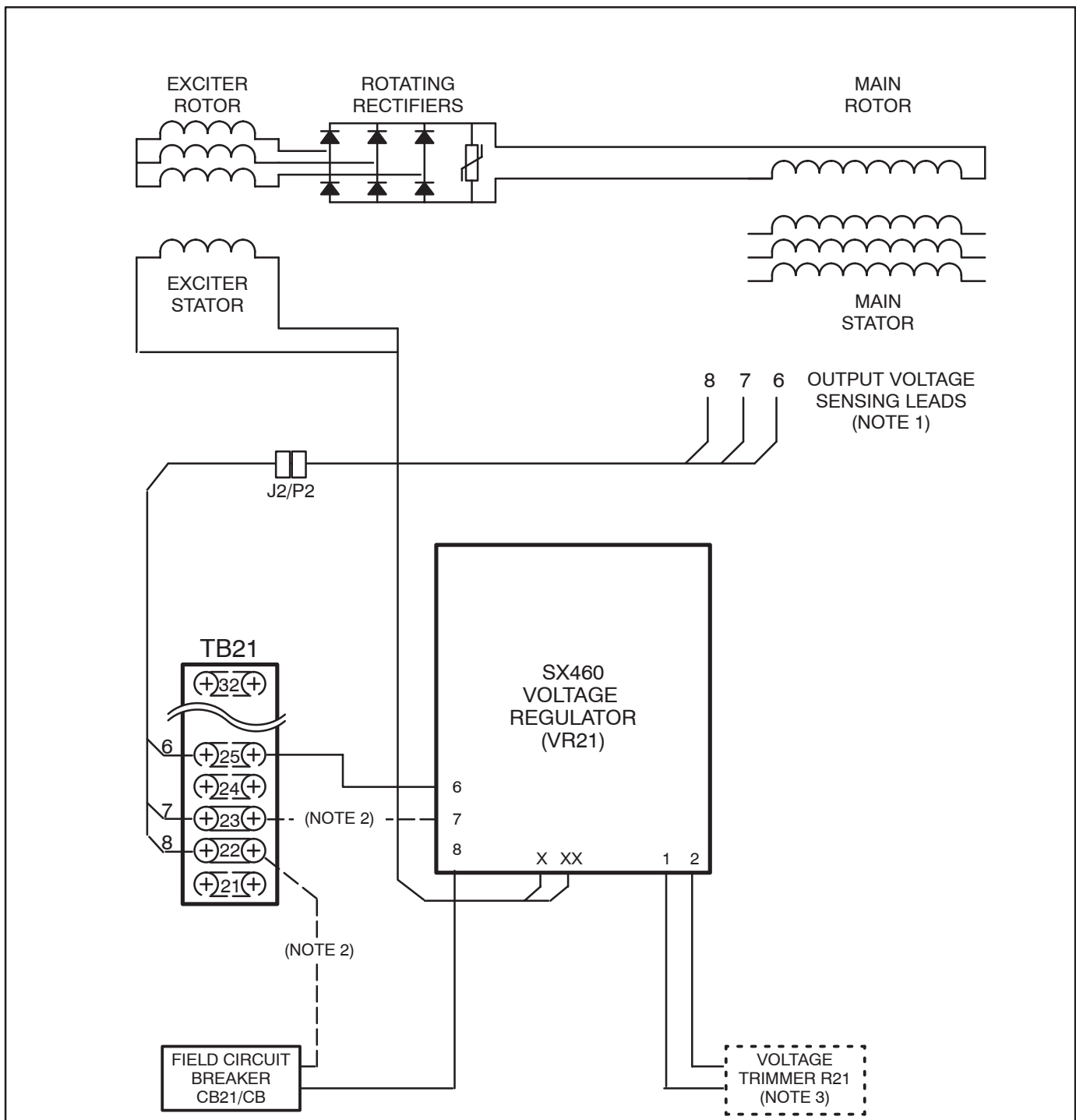

FIGURE 2-5. TYPICAL VOLTAGE REGULATING CIRCUITS FOR PMG-EXCITED GENERATORS



— NOTES —

- | | |
|--|--|
| <p>1. See the appropriate reconnection diagram for connecting sensing leads 6, 7, and 8.</p> <p>2. 600V Gensets: Generator tap leads 7 and 8 are used in place of these two leads.</p> | <p>3. There must be a jumper between voltage regulator terminals 1 and 2 when voltage trimmer R21 is not used.</p> |
|--|--|

FIGURE 2-6. TYPICAL VOLTAGE REGULATING CIRCUITS FOR SHUNT-EXCITED GENERATORS

PRINCIPLE OF GENERATOR OPERATION

1. The generator field (main rotor) is rotated by the engine to induce output current (AC) in the main stator windings.
2. Generator output current is proportional to field strength, which is varied to match the load. Output voltage and frequency are held constant by the voltage regulator and engine governor, respectively.
3. Generator field strength is proportional to field current, which is supplied by the exciter.
4. The exciter field (stator) induces current in the exciter rotor windings. A full wave rectifier bridge (rotating rectifiers) mounted on the exciter rotor converts exciter output (3-phase AC) to DC. The exciter rotor is mounted on the main rotor shaft.
5. Exciter output current is proportional to exciter field current.
6. The automatic voltage regulator (AVR) regulates exciter field current by comparing generator output voltage and frequency with reference values.
7. **PMG-Excited Generators.** Exciter field current is supplied by a PMG (permanent magnet) exciter through the voltage regulator. The PMG consists of a stator and a permanent magnet rotor mounted on the end of the main rotor shaft.
8. **Shunt-Excited Generators.** Exciter field current is supplied by the generator stator through the voltage regulator. Residual field magnetism initiates “self-excitation” during startups.

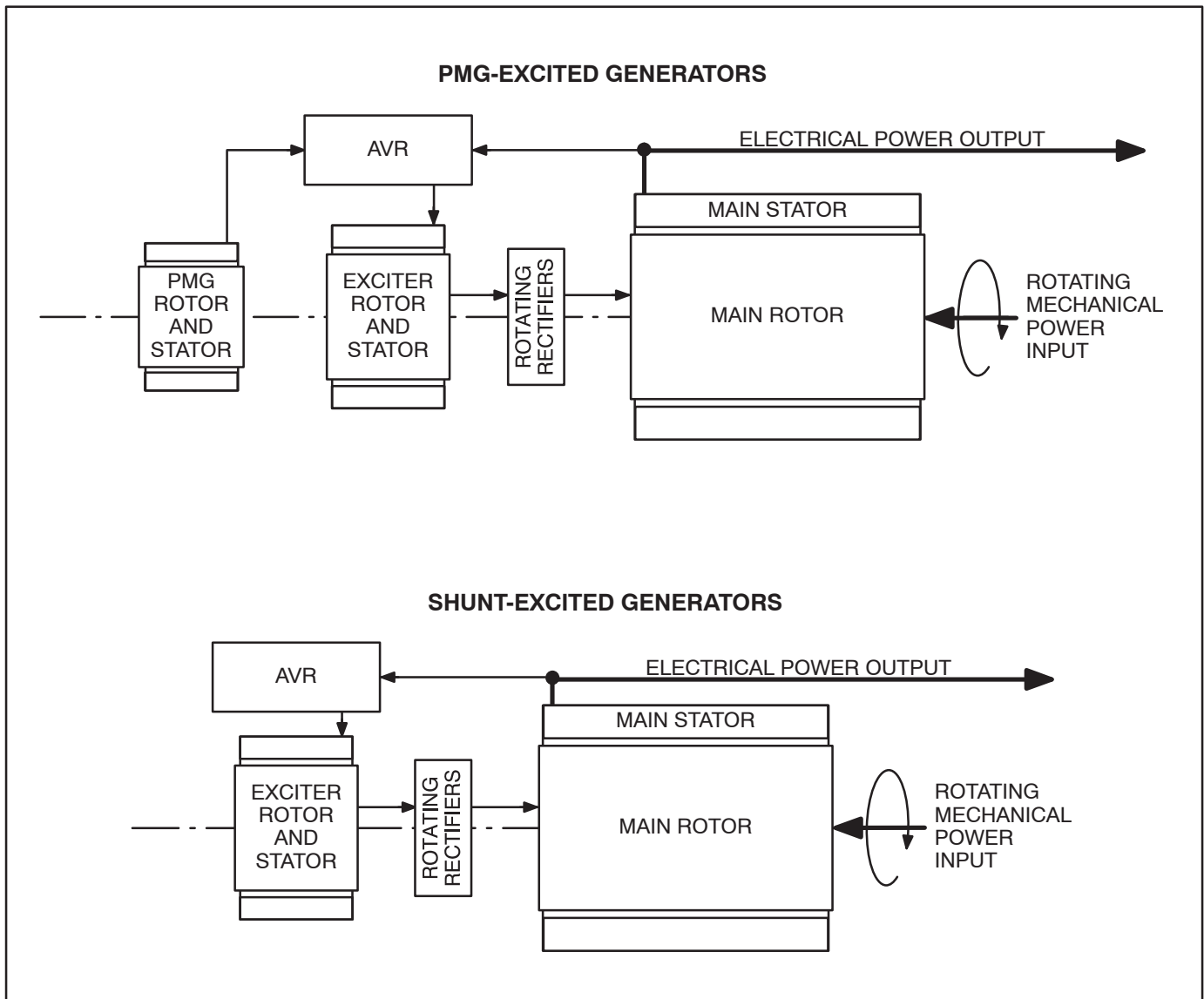

FIGURE 2-7. SCHEMATIC OF GENERATOR OPERATION

UFRO FREQUENCY ADJUSTMENT FOR TURBO GENSETS

To lower the frequency by 0.5 hertz (turbo gensets only) for UFRO adjustment, connect the two **UFRO TEST** leads together (Figure 2-8). When connecting or disconnecting these leads, the genset must be **OFF**.

One of the test leads is located in the harness sleeving and the other extends from connector J-A12 of the governor. After the test is complete, return and secure the test leads to the same location prior to removal.

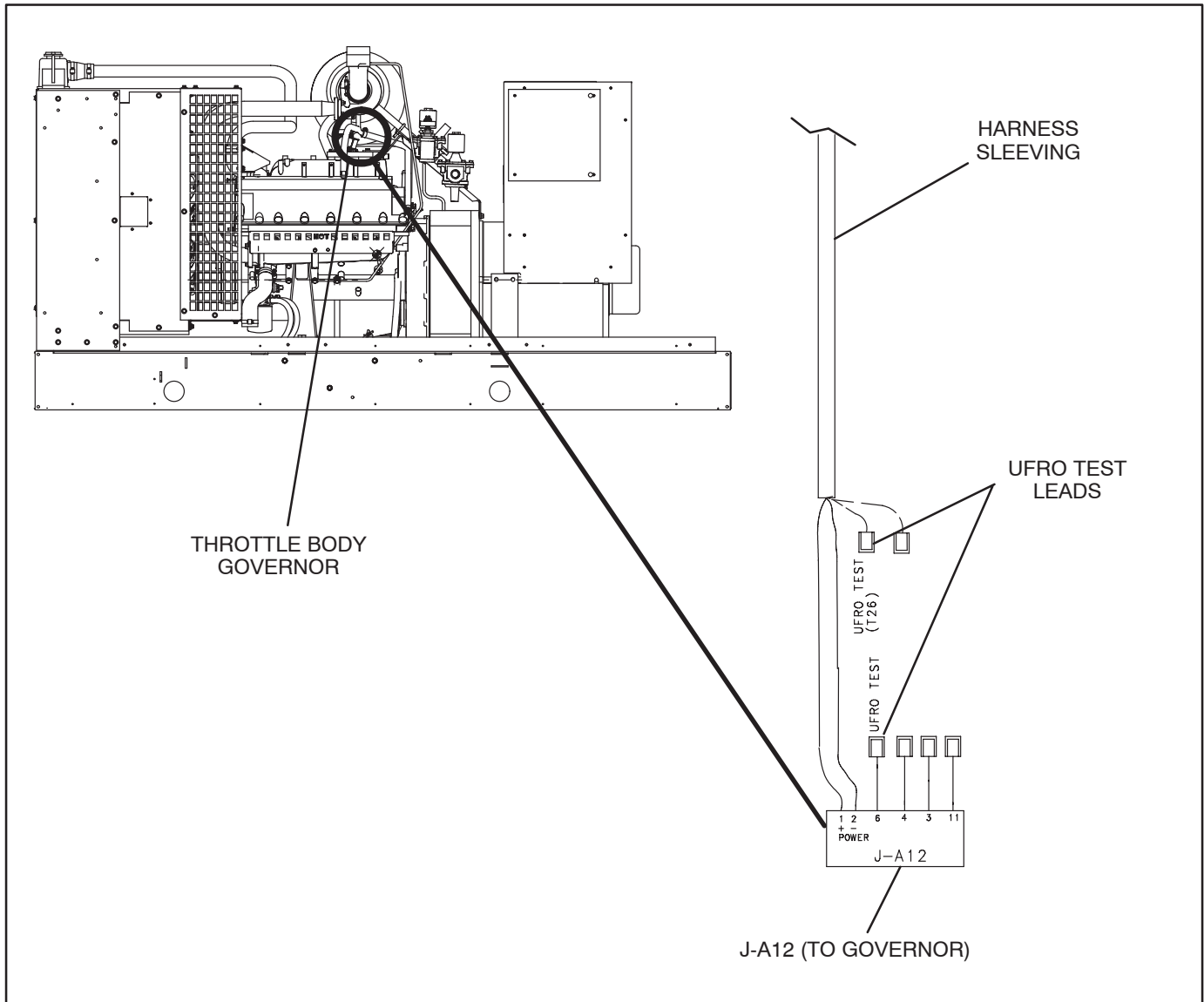

FIGURE 2-8. UFRO TEST LEAD LOCATION

3. Engine Control

GENERAL

The control box is mounted on top of the generator, facing the rear. Figure 3-1 shows the components on the engine control panel.

CONTROL PANEL COMPONENTS

Run / Stop / Remote Switch (S12) Starts and stops the set locally, or from a remote location wired to the control engine monitor board.

Reset / Lamp Test / Panel Lamp Switch (S11) Resets the fault circuit only when the Run/Stop/Remote switch is in the Stop (Rest) position. Tests fault lamps and turns on the control panel lamp.

Oil Pressure Gauge (M11) Indicates pressure of lubricating oil in engine. Normal oil pressure is 40 to 65 psi (276 to 449 kPa) at normal operating temperature.

Coolant Temperature Gauge (M12) The coolant temperature gauge indicates engine coolant temperature. Engine coolant temperature is typically between 165° to 195° F(74° to 91° C).

DC Voltmeter (M13) The DC voltmeter indicates voltage across the battery terminals during operation.

Hour Meter (M14) The hour meter indicates the accumulated number of hours the set has run. It cannot be reset.

Panel Lamp (DS11) The panel lamp illuminates the control panel.

Emergency Stop Button (S14) (Optional) Push-in switch for emergency shutdown of the engine. To reset, pull switch out and move Run/Stop/Remote switch to Stop position. Then push test switch to Reset/Lamp Test position.

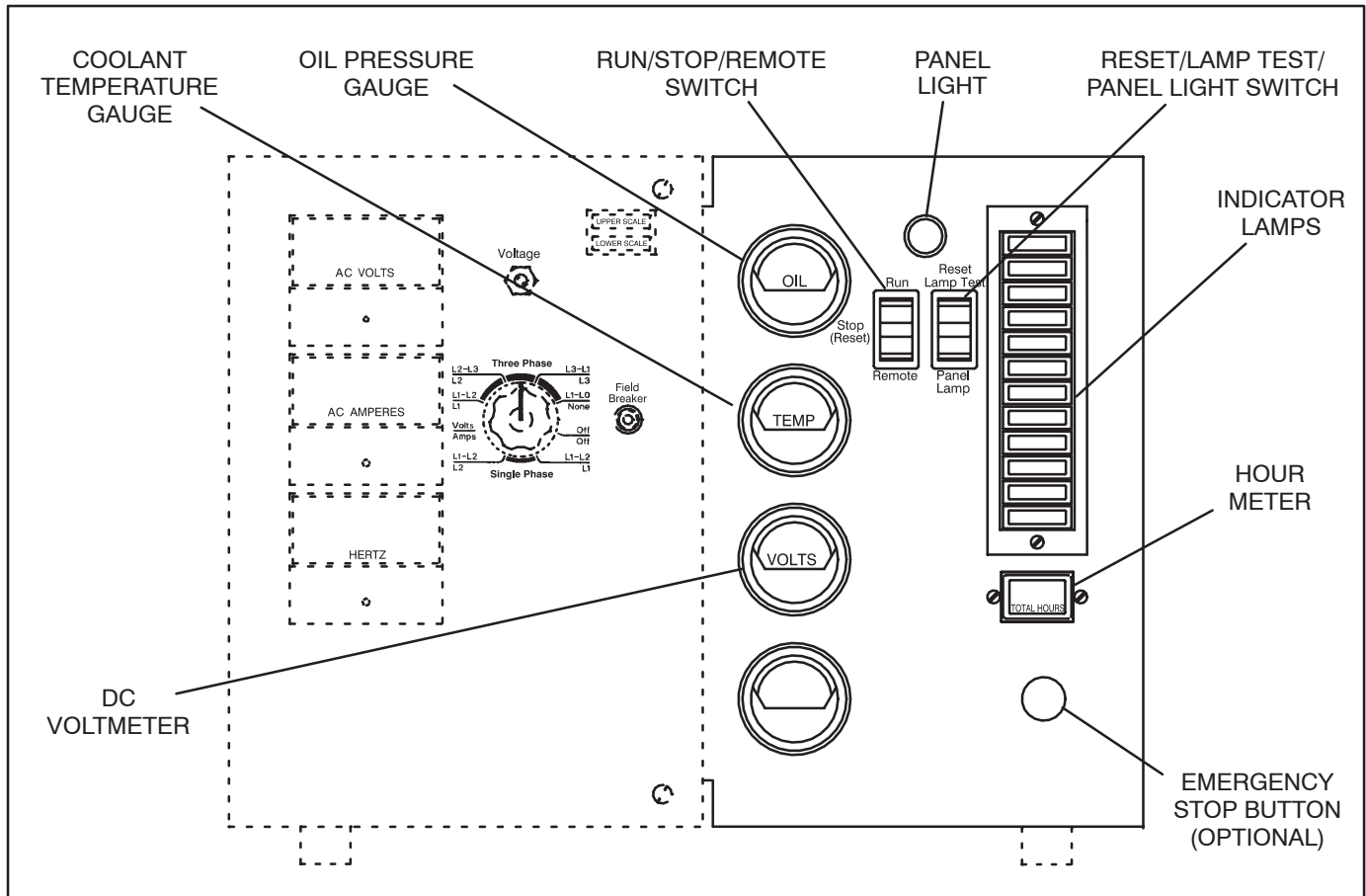

FIGURE 3-1. ENGINE CONTROL PANEL

Fault and Status Indicator Lamps (A12)

- **Run (Green)** Indicates that the starter has disconnected and that the set is running.
- **Pre Low Oil Pressure (Yellow)** Indicates that engine oil pressure is abnormally low (less than 30 psi [207 kPa]).
- **Pre High Engine Temperature (Yellow)** Indicates that engine coolant temperature is abnormally high (greater than 220° F [104° C]).
- **Low Oil Pressure (Red)** Indicates that the engine shut down because of excessively low engine oil pressure (less than 25 psi [173 kPa]).
- **High Engine Temperature (Red)** Indicates that the engine shut down because of excessively high engine coolant temperature (greater than 230° F [110° C]).
- **Overspeed (Red)** Indicates that the engine shut down because of overspeed. The overspeed shut down range for 50/60 Hz is:
Naturally Aspirated Sets 2250 ±30 RPM
Turbo Sets 2400 ±30 RPM
- **Overcrank (Red)** Indicates that the engine shut down because it did not start during the timed cranking period (approximately 75 seconds, including two rest periods).
- **Fault 1 (Red)** Indicates that the engine shut down because of a system fault. The customer

has to make connections to use this lamp. The lamp is a part of a 10 second time delay shutdown circuit. The customer can make reconnections for non-timed shutdown. See Engine Control Monitor.

- **Fault 2 (Red)** Indicates that the engine shut down because of a system fault. The customer has to make connections to use this lamp. The lamp is part of a non-time delay shutdown circuit. The customer can make reconnections for 10 second time delay shutdown. See Engine Control Monitor.
- **Low Engine Temperature (Yellow)** Indicates that engine temperature is less than 65° F (18° C) or 90° F (32° C), and the possibility that the engine might not start. (Temperature is selectable if control contains a Sensor board. Without Sensor board, LET is 70° F [21° C].)
- **Low Fuel (Yellow) (Optional)** Indicates fuel supply pressure is 5 inches (127 mm) WC or less for dual or single fuel systems. With dual fuel system, also indicates that genset is operating on secondary fuel supply.
- **Switch-off (Flashing Red)** Indicates that the **Run/Stop/Remote** switch is in the **Stop** position, which prevents remote, automatic operation.

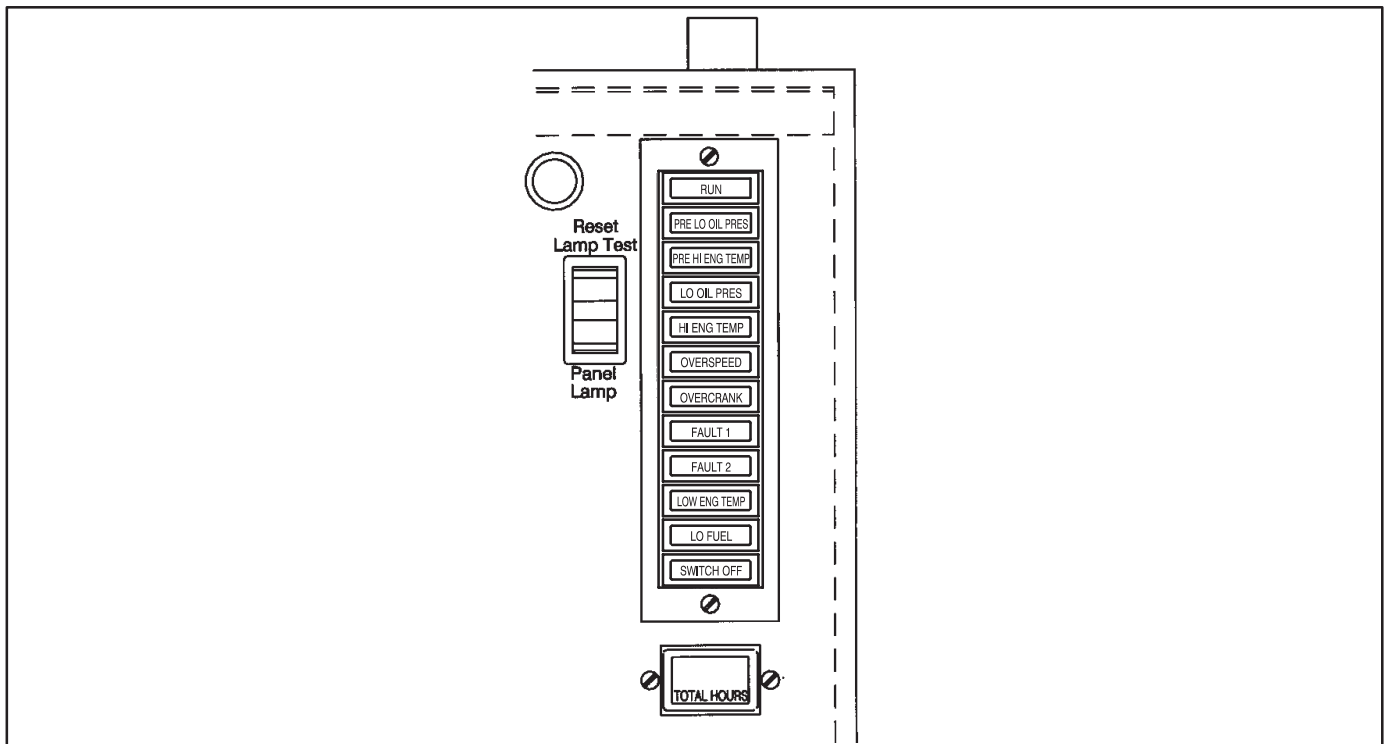

FIGURE 3-2. INDICATOR LAMPS

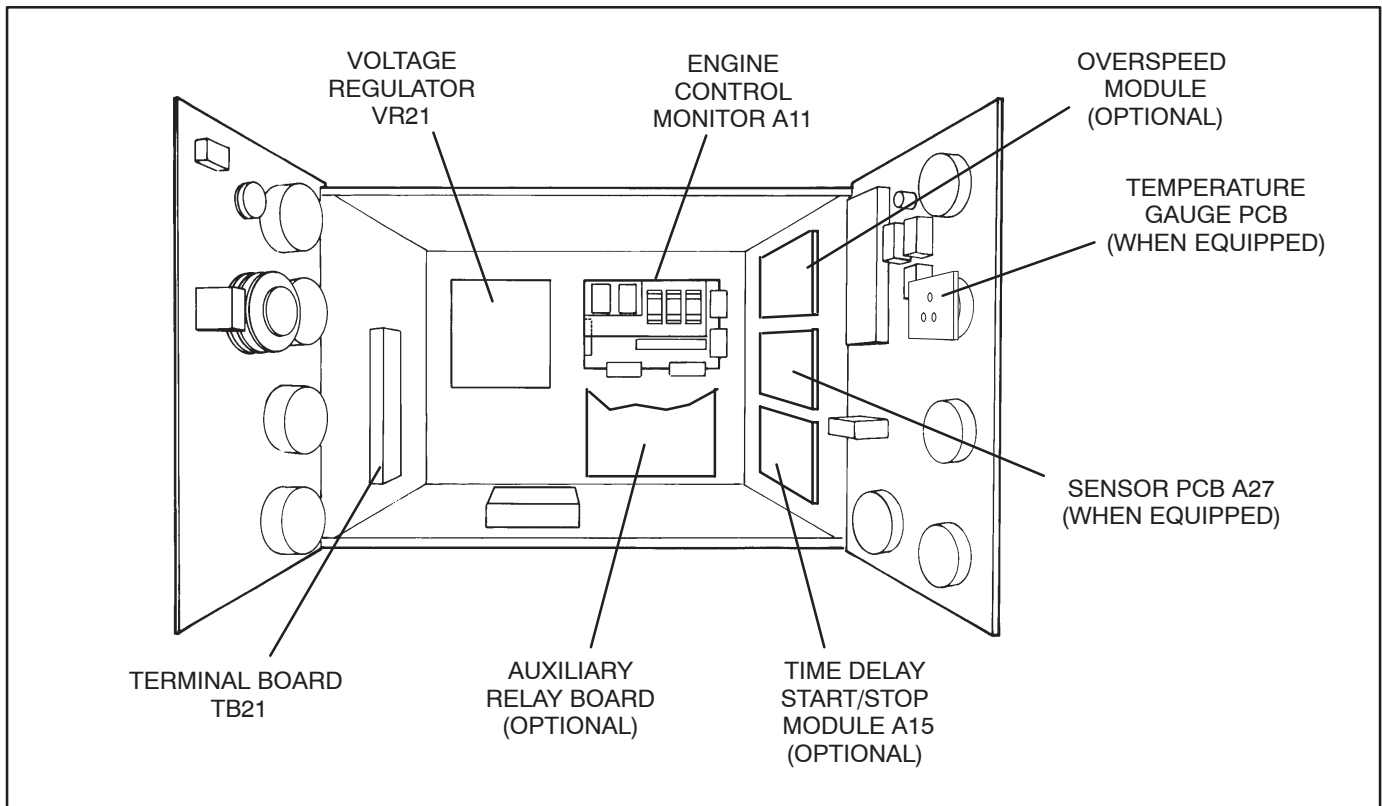

FIGURE 3-3. ARRANGEMENT OF COMPONENTS INSIDE THE CONTROL BOX

CONTROL BOX INTERIOR

Figure 3-3 shows the arrangement of components inside the control box, including the engine control monitor and some of the auxiliary components under the following headings.

ENGINE CONTROL MONITOR (A11)

The heart of the engine control system is the engine control monitor (ECM) (Figure 3-4). It is a printed circuit board assembly mounted on the back wall of the control box. It starts and stops the engine in response to the control panel switches, engine sensors and remote control signals.

Note that there are two versions of the ECM board and that they both perform the same functions. They only differ in that one version contains additional components, which are, LED's (**DS1 – DS9**), terminal board (**TB3**) and function selection jumper **W10**. Figure 3-4 illustrates the ECM version which contains the additional components.

LED's DS1 through DS9

The ECM LED's are provided as an aid in troubleshooting the control circuitry. The LED's indicate the following conditions:

LED	STATUS WHEN ILLUMINATED
DS1	B+ is connected to ECM and fuse F4 is good.
DS2	RUN relay is energized.
DS3	Start Command signal enabled.
DS4	Crank signal enabled.
DS5	DC Starter Disconnect signal enabled.
DS6	AC Starter Disconnect signal enabled.
DS7	LOP/HET signal active (time delay circuit has timed-out).
DS8	Reverse battery voltage.
DS9	Remote Shutdown signal active (grnd at TB2-16)

Terminals and Connectors

See Pages 7-7 through 7-11 for the appropriate connection and schematic drawings for the DC control system. See Page 7-12 for typical customer connections at terminal boards **TB1** and **TB2** on the ECM and page 7-13 if the set is also equipped with the auxiliary relay board.

Terminal board **TB3** provides an alternative direct connection to the ECM for the RUN/STOP/REMOTE switch for troubleshooting or if desired, customer connection.

TB3-1 = REMOTE

TB3-2 = RUN

TB3-3 = STOP

Fuses

The ECM has five replaceable fuses to protect it from overloads and ground faults. They are:

F1 Starter solenoid circuit, 20 amps.

F2 Fuel solenoid (switched B+) circuits, 20 amps.

F3 Continuous B+ out to remote circuits, 15 amps.

F4 ECM circuits, 5 amps.

F5 Engine gauge circuits, 5 amps.

Function Selection Jumpers

ECM board has seven selection jumpers that can be repositioned to provide the following timed or non-timed warnings or timed or non-timed shutdowns with warnings, and control of the SWITCH OFF indicator:

W1 Jumper Position (jumper **W8** must be in the **B** position):

A Non-timed warning under **FLT 2** conditions.

B Non-timed shutdown under **FLT 2** conditions.

C Timed warning under **FLT 2** conditions.

D Timed shutdown under **FLT 2** conditions.

W2 Jumper Position (jumper **W9** must be in the **B** position):

A Non-timed warning under **FLT 1** conditions.

B Non-timed shutdown and under **FLT 1** conditions.

C Timed warning under **FLT 1** conditions.

D Timed shutdown under **FLT 1** conditions.

W6 Jumper Position:

A Warning under **Pre-High Engine Temperature** conditions.

B Shutdown under **Pre-High Engine Temperature** conditions.

W7 Jumper Position:

A Warning under **Pre-Low Oil Pressure** conditions.

B Shutdown under **Pre-Low Oil Pressure** conditions.

W8 Jumper Position:

A Warning while running or during standby under **FLT 2** conditions.

B Allows selection of functions with **W1** jumper.

W9 Jumper Position:

A Warning while running or during standby under **FLT 1** conditions.

B Allows selection of functions with **W2** jumper.

W10 Jumper Position (**SWITCH OFF** Indicator):

A Flashing

B Constant ON

C OFF

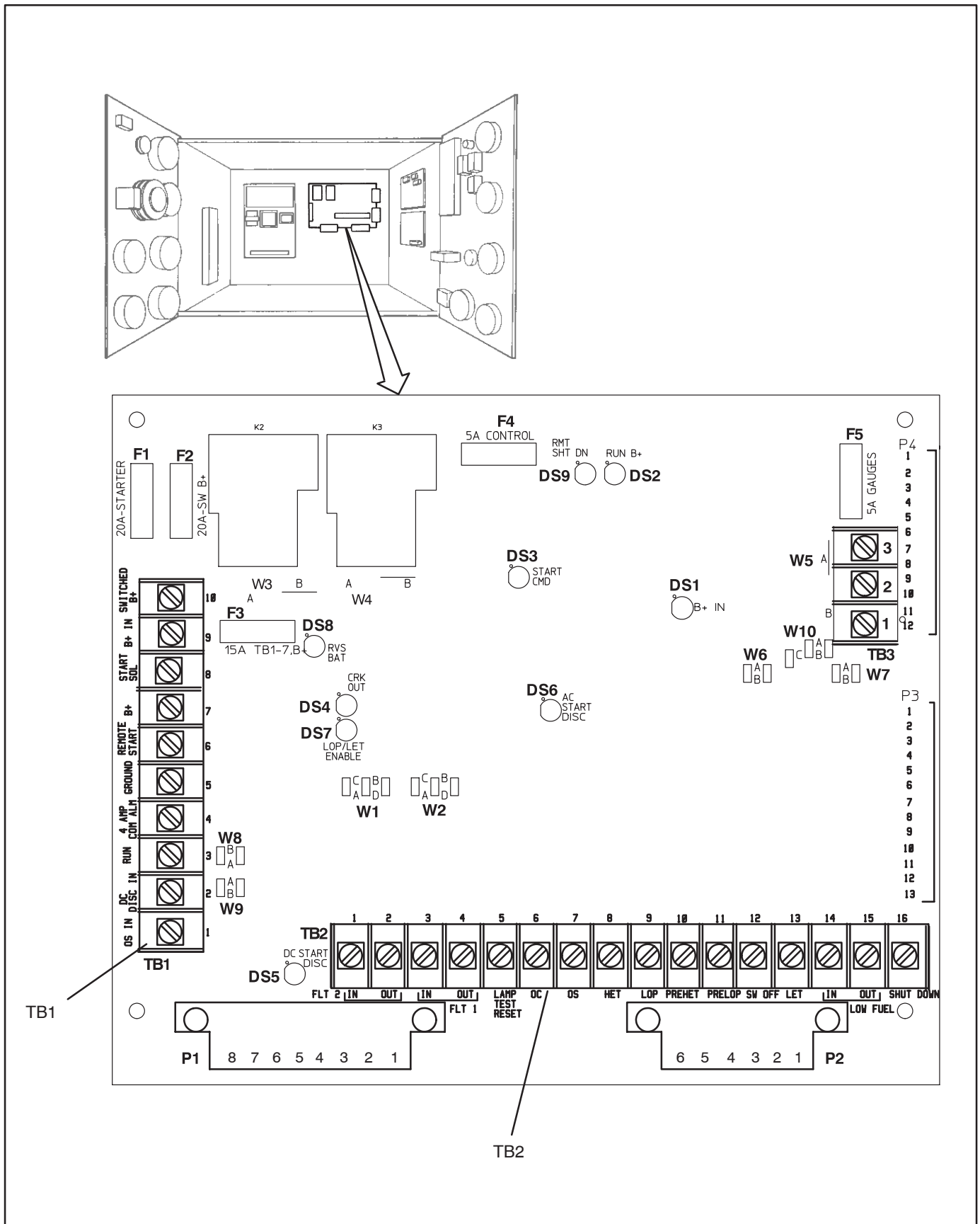

FIGURE 3-4. ENGINE CONTROL MONITOR FUSES AND FUNCTION SELECTION JUMPERS

ENGINE SENSORS

Figure 3-5 and 3-6 shows the locations of the coolant temperature and oil pressure senders for the V10 and V6 engine. The senders function by varying the resistance with temperature or pressure in series with the gauge.

Always use pipe thread sealant on gauge senders and warning and shutdown switches.

⚠ CAUTION *Teflon tape should not be used on switches and senders that are grounded to the engine by thread contact as it may interfere with the ground path.*

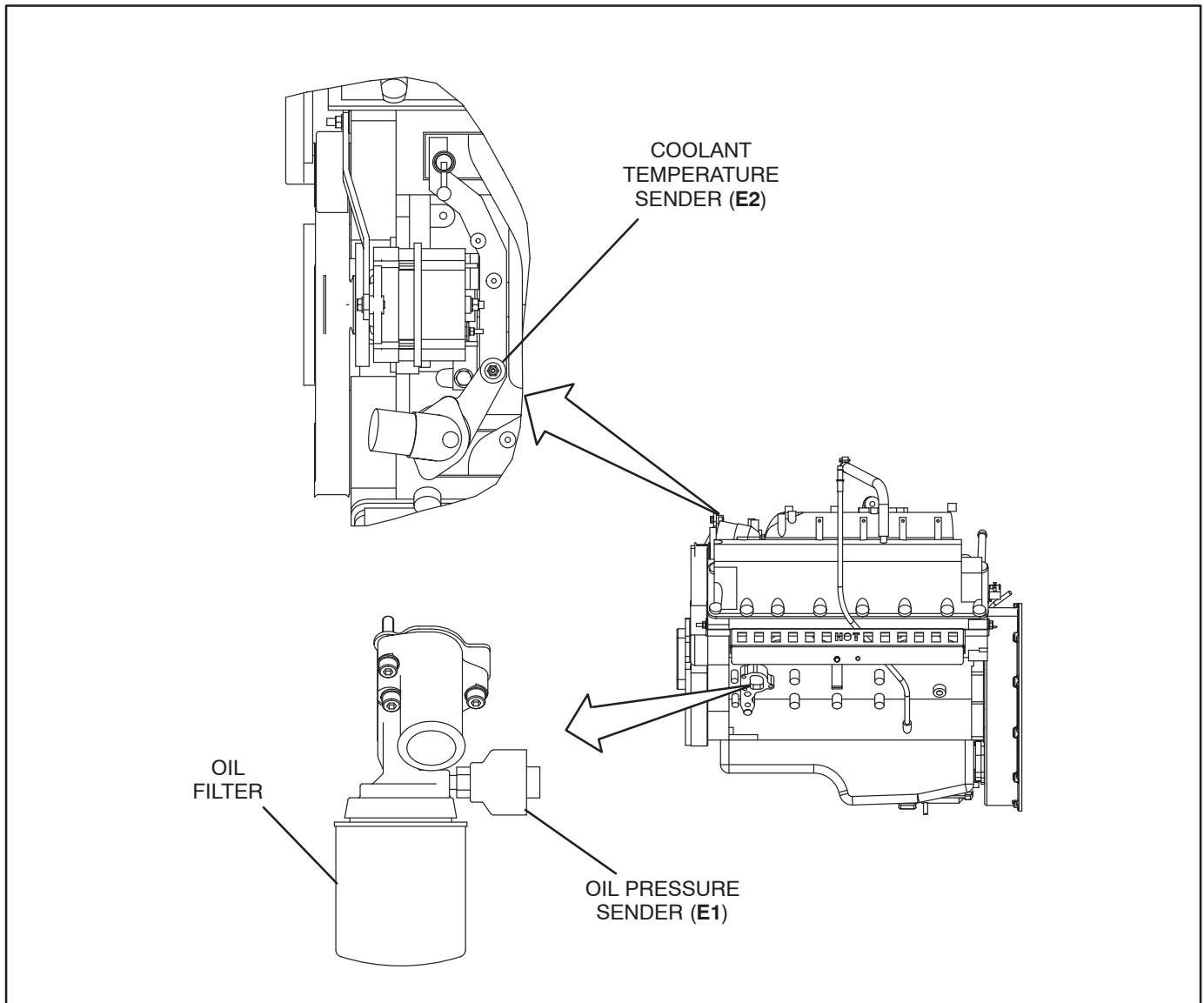

FIGURE 3-5. V10 ENGINE SENSOR LOCATIONS

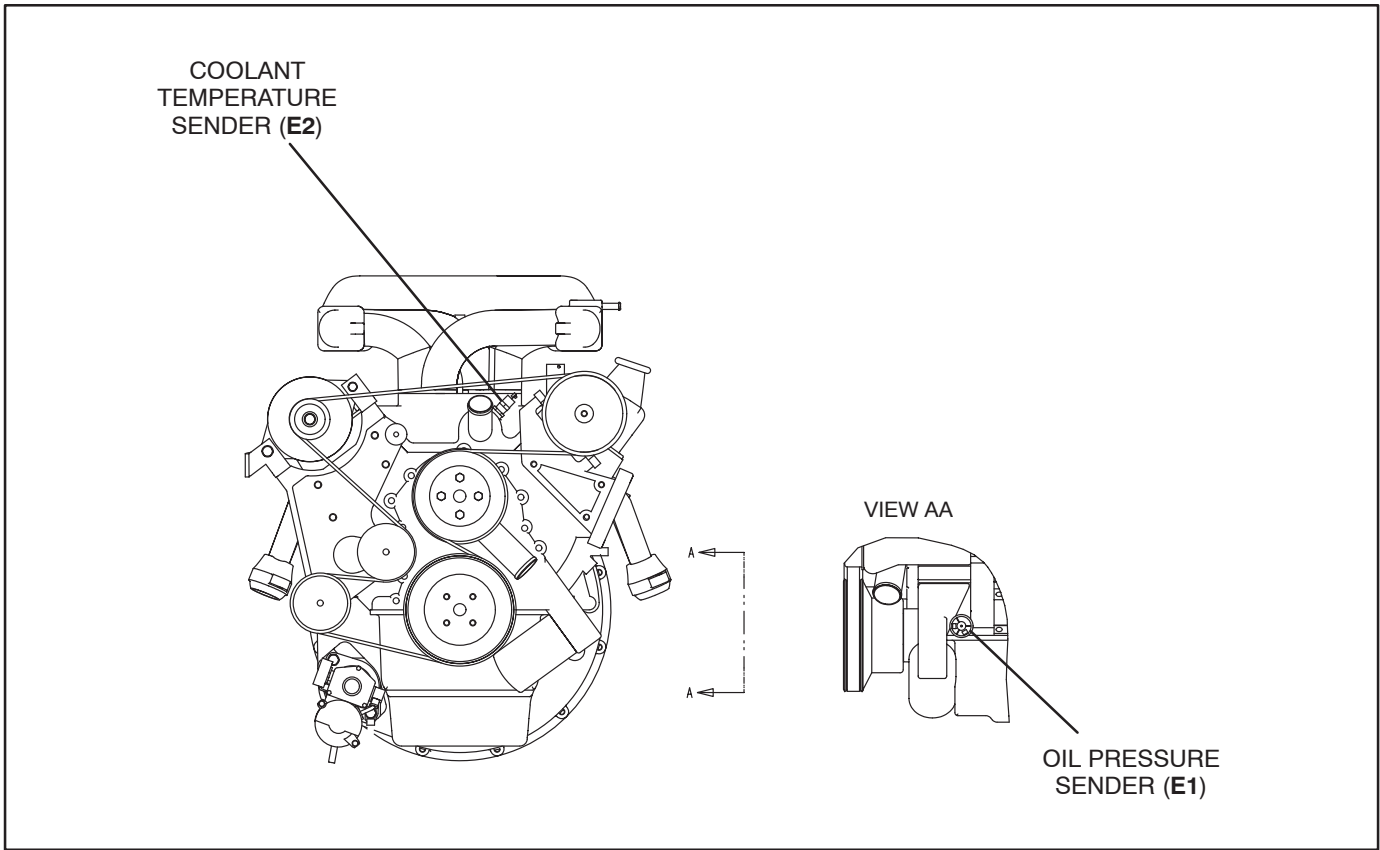

FIGURE 3-6. V6 ENGINE SENSOR LOCATIONS

Low Coolant Level Cutout Switch

When coolant level in the radiator top tank falls below the switch sensor, the switch closes the circuit to ground.

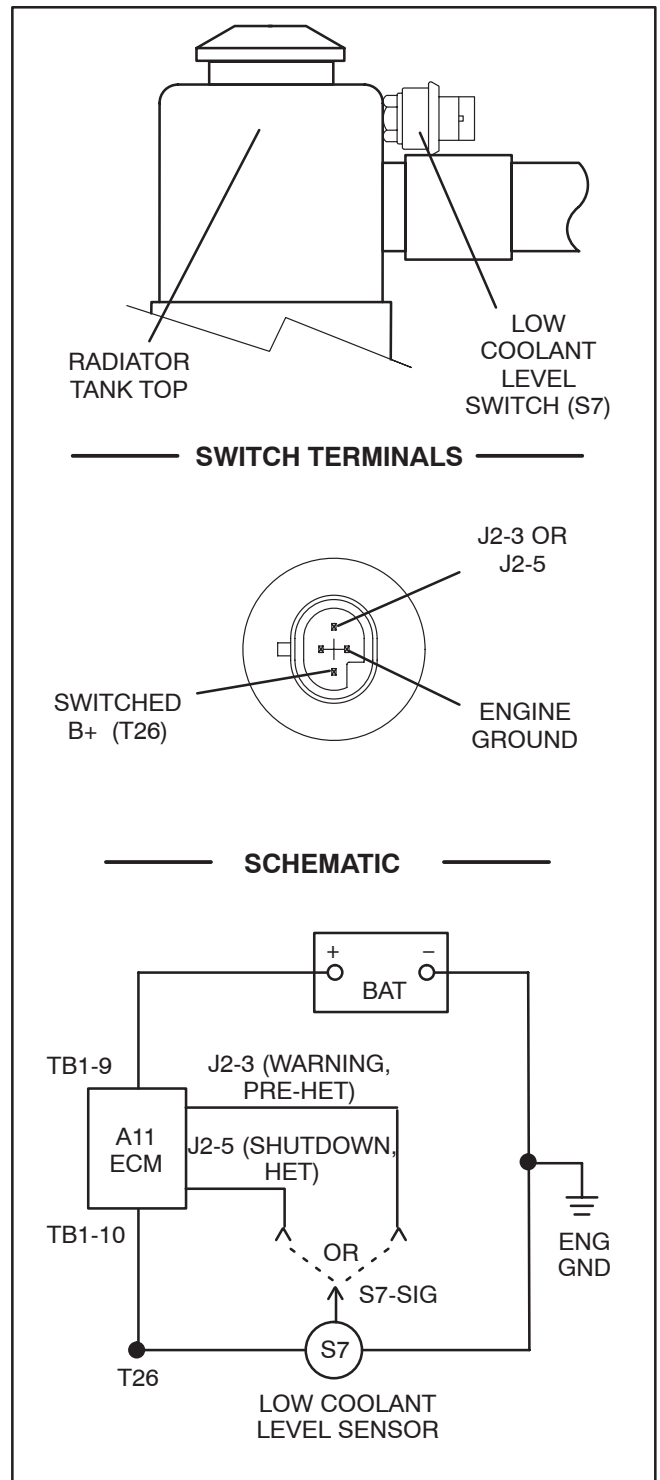

FIGURE 3-7. LOW COOLANT LEVEL SWITCH

Coolant Temperature/Oil Gauge and Warning Light Circuits

The Sensor board is mounted on the right side of the control box. This Sensor board interprets the output signals of the coolant temperature and the oil pressure senders and in turn sends these signals to the ECM (A11) board for the following functions:

- Pre-HET (pre-high engine temperature)
- HET
- Pre-LOP (pre-low oil pressure)
- LOP
- LET (low engine temperature)
- Oil pressure gauge signal
- Coolant temperature gauge signals

The Sensor board contains two selectable jumpers, one for LET and the other for LOP.

The LET jumper allows a choice of the Low Engine Temperature warning to be either 65° F (18° C) or 90° F (32° C). (Suggested setting is 65° F.)

The LOP jumper allows a choice for Low Oil Pressure shutdown: 14 psi (97 kPa) and 25 psi (173 kPa). Make sure the LOP jumper is set to 25 psi (173 kPa). The associated Pre-LOP warning light changes between 20 psi (138kPa) and 30 psi (207 kPa) respectively.

CAUTION *The engine can be damaged if the engine continues to run with oil pressure less than 25 psi (173 kPa). Make sure the LOP jumper is set to 25 psi (173 kPa) for all engines.*

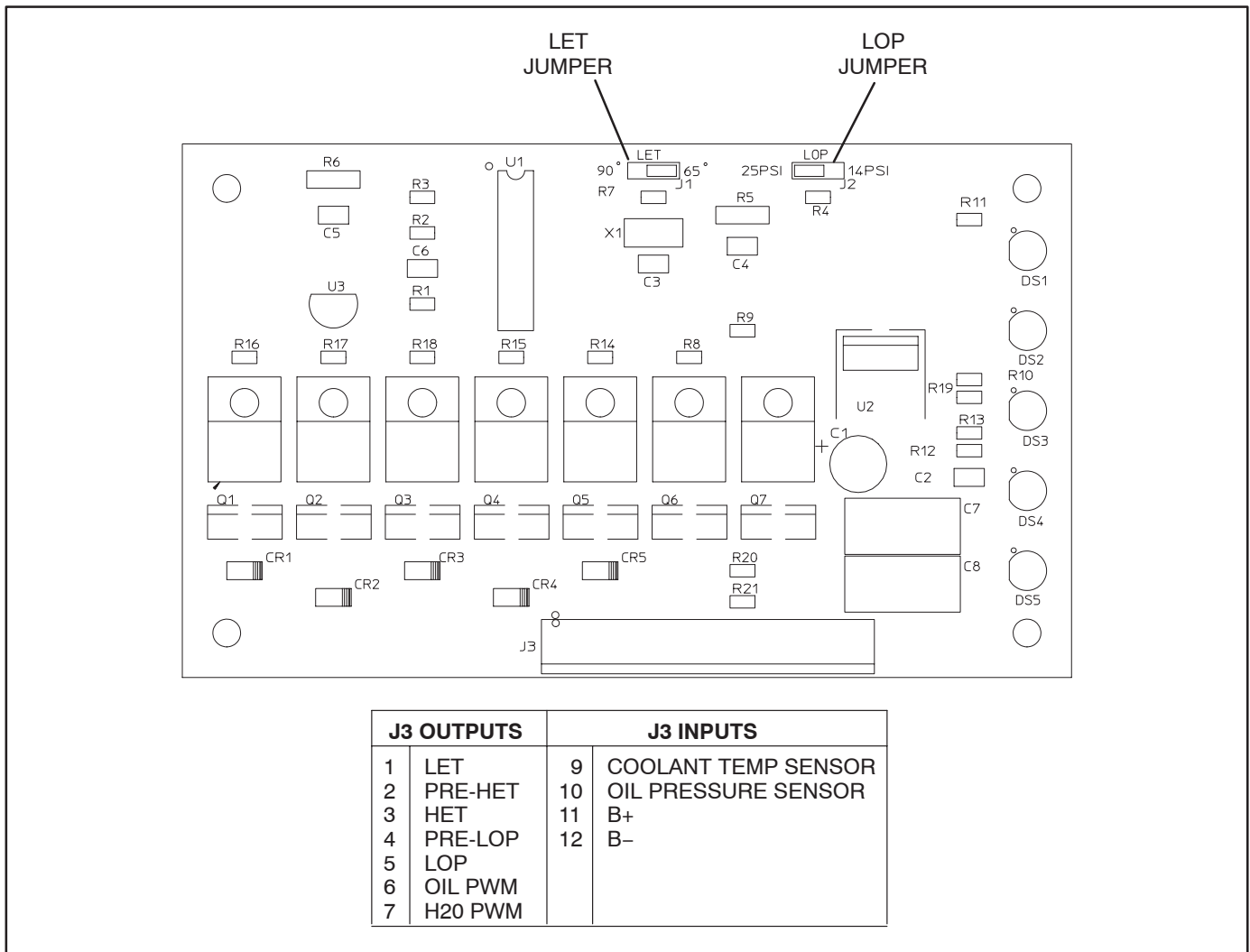

FIGURE 3-8. SENSOR BOARD PCB ASSEMBLY

MAP SENSOR (V10 TURBO ONLY) (OPTIONAL)

Figure 3-9 shows the location of the MAP sensor. The MAP sensor is used to prevent engine damage by limiting the engine from exceeding its designed maximum power output.

The MAP sensor functions by varying the resistance with boost pressure. With 5VDC supplied to the sensor, the output signal (which varies with boost pressure) is supplied to the governor to control the power output of the engine.

Testing MAP Sensor

A defective MAP sensor can cause the engine to lack power (kW rating can not be obtained). Before testing the operation of the MAP sensor, check all

other conditions that can cause loss of power (refer to “The Engine Lacks Power Or Is Unstable” in Section 4).

With MAP sensor disconnected, the engine can exceed its designed maximum power output to compensate for other conditions that can be causing loss of power, such as fuel system misadjustments, dirty air filter, etc. Problem may return after replacing MAP sensor, indicating power loss is due to other conditions.

To test the MAP sensor, shut down the set and remove the plug from the MAP sensor. Start the set and check for maximum kW rating of set. If set operates properly, MAP sensor may be defective.

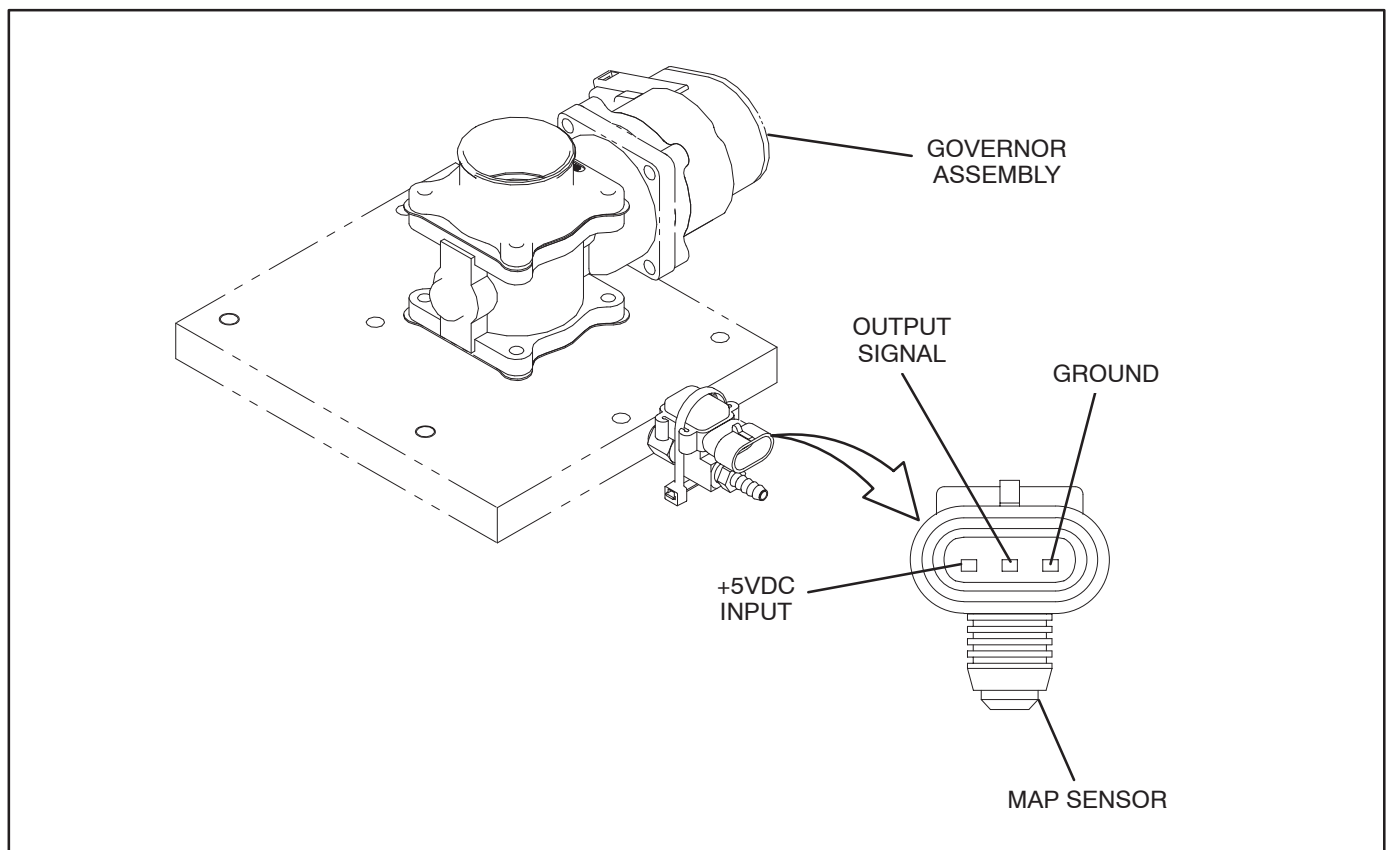

FIGURE 3-9. MAP SENSOR (V10 TURBO ONLY)

IGNITION CONTROL MODULE (ICM)

Figure 3-10 shows the location of the ignition control module (ICM).

V10 Ignition System

The ICM controls the firing pulses to the ten separate ignition coils that are mounted directly on the spark plugs (coil-on-plug). To reduce radio frequency interference from the ignition coils, capacitors are installed in the ignition harness. Defective or disabled capacitors may result in erratic movement of the engine gauges or engine starting/running performance.

V6 Ignition System

The ICM controls the firing pulses to the spark coil pack which delivers the high voltage to the spark plugs.

ICM Input Signals

For proper operation, the ICM requires input signals from the following sensors/switches:

CRANKSHAFT sensor – Provides crankshaft position and speed by sensing a missing tooth on a pulse wheel mounted on the crankshaft.

CAMSHAFT sensor (V10 only) – Identifies cylinder one by monitoring a target on the camshaft sprocket.

CYLINDER HEAD TEMPERATURE sensor – Monitors engine temperature of engine. ICM will

stop the spark firing pulses if engine reaches 250° F (121° C).

OIL PRESSURE switch – Not used, switch lead must be grounded to engine intake manifold.

FUEL SELECT – Proper connection of the engine harness terminals **P10**, **P11** and **K1** must be made for the generator set fuel type:

Natural Gas, **P11 to P10 (B+)**

Propane, **P11 to K1– (Engine Ground)**

Dual Fuel, Automatically switched

ICM Output Signals

The ICM provides the following output signals:

STARTER DISCONNECT – At 600 RPM a ground signal is supplied to the starter disconnect relay (K13F).

ENGINE FAULTS – The ICM fault signal is connected to A11 J2-6 (ECM Overspeed input). The control will indicate an overspeed fault if one of the following engine faults occur:

Overspeed: Engine speed has reached 2250±30 RPM (naturally aspirated genset) or 2400±30 RPM (turbo genset).

High Engine Temperature: Engine temperature has reached 250° F (121° C).

Low Oil Pressure: Oil pressure switch lead not connected to grounded will activate ICM fault signal.

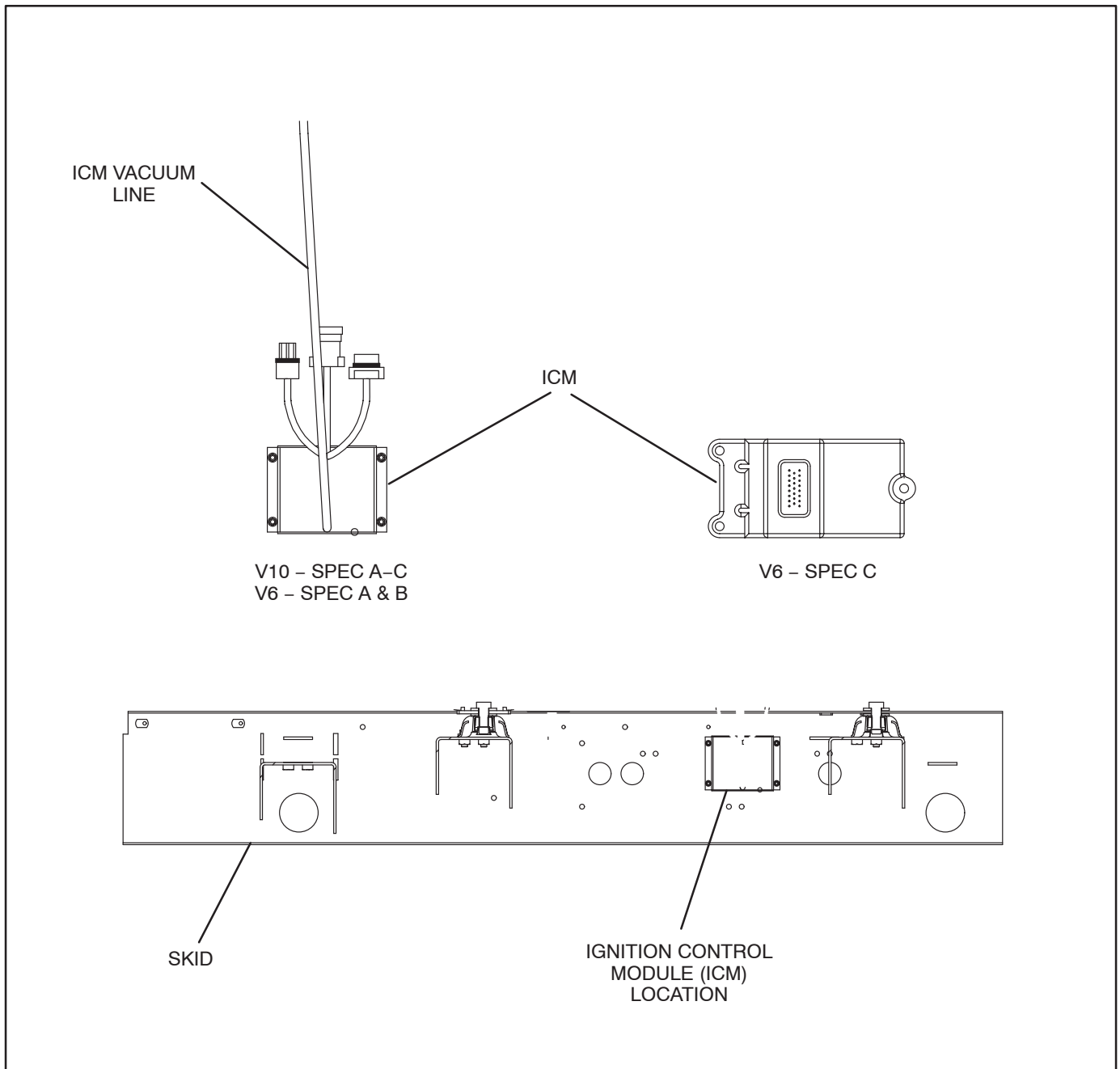

FIGURE 3-10. IGNITION CONTROL MODULE (ICM)

AUXILIARY CONTROL COMPONENTS

The set might be equipped with one or more of the following components.

Auxiliary Relay Board (ARB) (Optional)

The following describes the design/functional criteria for the auxiliary relay board (ARB) (Figure 3-11). The board is mounted directly on top of the ECM using standoffs and has access holes for the fuses located on the ECM. Page 7-13 is a detailed connection diagram for the ARB.

Terminal Blocks

TB1 – ARB TB1 and ECM TB1 are identically numbered and provide the same remote control connection points. Note that additional terminals are provided for terminals 5, 7, and 10 of ARB TB1.

TB2 through TB5 – Connection points for relays K1 through K3. TB2 provides the N/O and N/C connections (three form 'C' contacts for each relay). TB3 through TB5 provide the common connection points (TB3 for K1, TB4 for K2 and TB5 for K3).

TB6 and TB7 – Connection points for fault relays K4 through K15. Three terminals are provided for each relay, which are labeled COM, N/C, N/O.

Plug-In Relays (K1, K2, K3)

The ARB can be equipped with one to three 3-pole, double-throw relays. These relays (K1, K2, K3) are field changeable plug-in relays for easy field addition and replacement.

The relay contact ratings are:

- 10 amps at 28 VDC or 120 VAC, 80% PF
- 6 amps at 240 VAC, 80% PF
- 3 amps at 480 VAC, 80% PF

Each relay can be operated as a RUN, COMMON ALARM, or ISOLATED COIL with the changing of a jumper.

Jumper Positions for Plug-In Relays

Jumpers W1, W2, and W3 perform the same functions for their respective relays, W1 for relay K1, W2 for relay K2, and W3 for relay K3. They can

be located in any of 3 positions (A, B, C) independently of each other.

Jumper Position A (Run): The relay operates as a Run relay, energizing when SW B+ is applied from the ECM.

Jumper Position B (Common Alarm): The relay operates as a Common Alarm relay. The relay energizes any time there is an engine shutdown. This signal is provided from the ECM.

Jumper Position C (Isolated): The relay operates as an Isolated relay. The relay coil is energized by a customer applied B+ signal through the terminal block; TB3-1 for relay K1, TB4-1 for relay K2, and TB5-1 for relay K3.

Jumpers W11, W12, and W13 perform the same functions for their respective relays; W11 for relay K1, W12 for relay K2, and W13 for relay K3. They can be located in two different positions (A, B) independently of one another.

Jumper Position A: The relay operates isolated from the board. The customer provides the circuit completion through terminal block; TB3 for relay K1, TB4-5 for relay K2, and TB5-5 for relay K3. The customer can operate the relay with switched ground logic or use this relay in the middle of more complex logic circuits if needed.

Jumper Position B: The relays operate with the coils connected to ground through the board connections. The coil will require a B+ signal to energize with the jumper in this position.

Fault Relays (K4 through K15)

These relay modules are used to operate a remote alarm annunciator that has an independent power source. This allows the use of either AC or DC for alarm drives. The relays are energized through the latching relays on the ECM and provided N/O and N/C contacts for each external alarm connection.

The 12 relays with form 'C' contacts are rated:

- 10 Amp, 120 VAC
- 10 Amp, 30 VDC

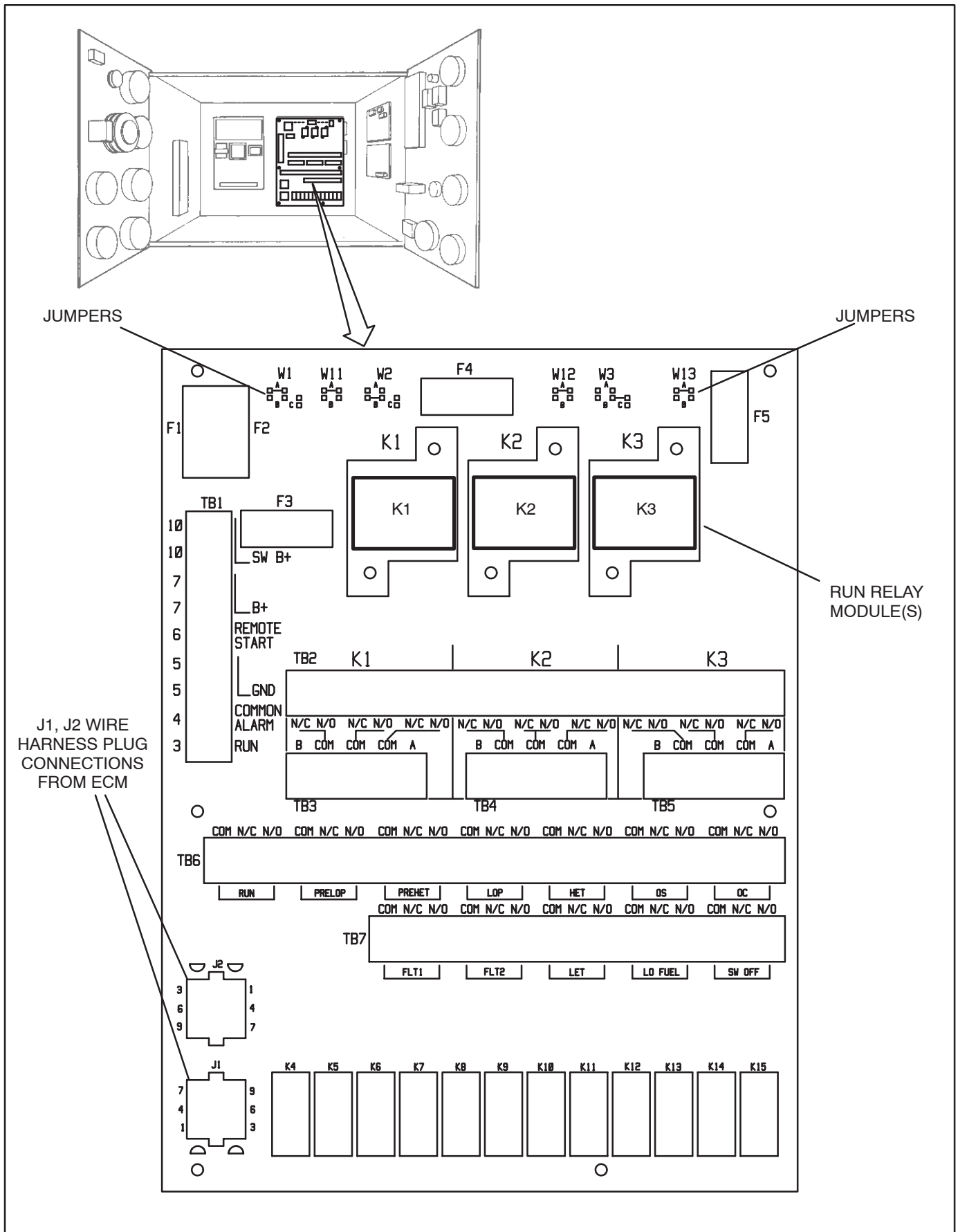

FIGURE 3-11. AUXILIARY RELAY BOARD

Time Delay Start / Stop Module (Optional)

The set can be equipped with a module to delay starting and stopping when the start and stop signals are received from the remote controller. It is adjustable to delay starts from 1 to 15 seconds to

prevent nuisance starts in installations where momentary power interruptions are frequent. It is adjustable to delay stops 1 to 30 minutes to allow the prime source of power time to stabilize and the generator set to cool down.

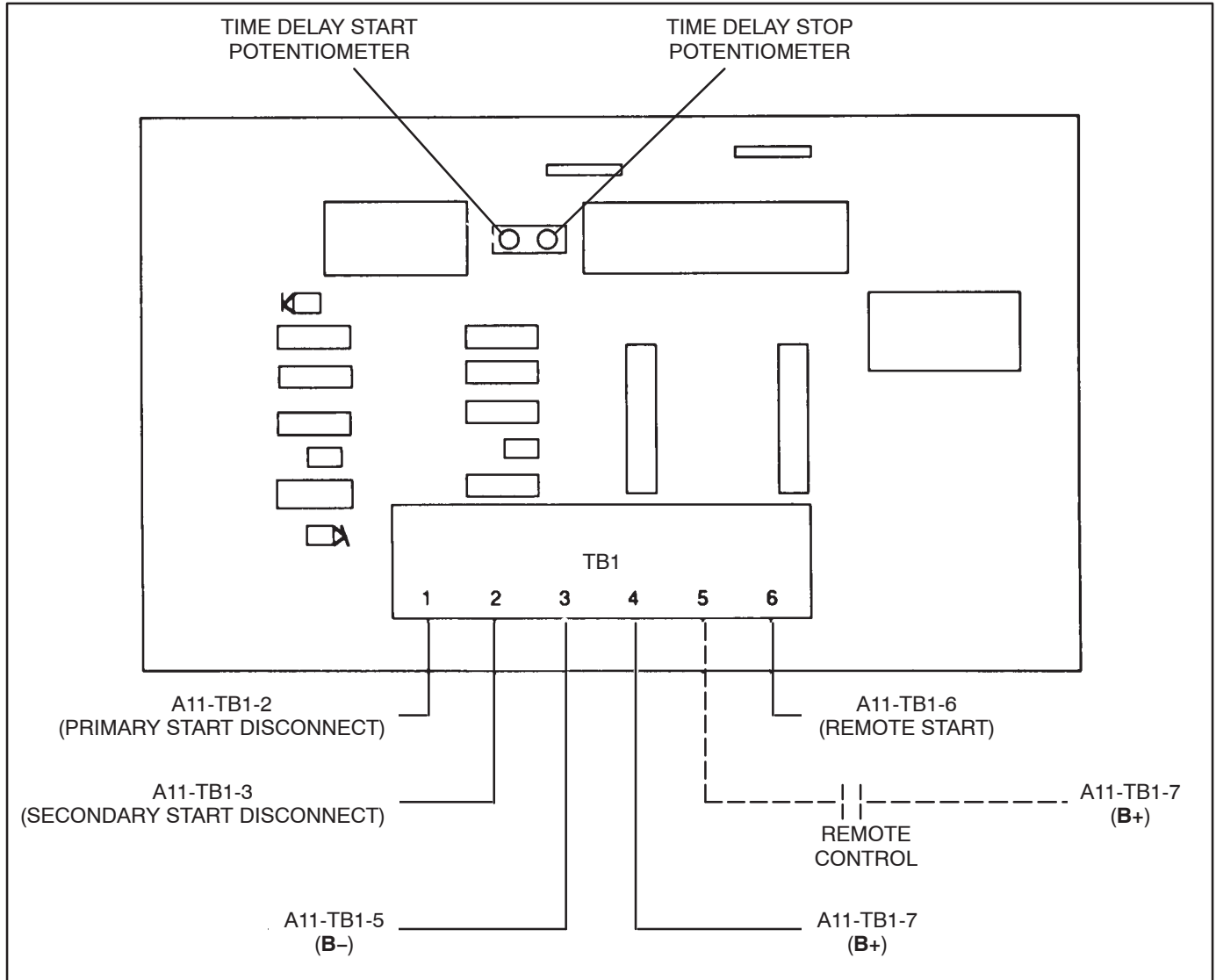

FIGURE 3-12. TIME DELAY START / STOP MODULE (A15)

SEQUENCE OF OPERATION

The sequence of operation is as follows. Refer to the schematic on Page 7-8.

1. The ECM is powered by cranking battery voltage (12 VDC). Terminal **TB1-9** is connected to battery positive (+) and connector **P1-6** to battery negative (-).
2. The starting cycle begins when relay **K7** is powered, either manually by pushing the panel **Run** switch, or automatically by a remote controller connected at terminal **TB1-6**. (The panel switch must be in the **Remote** position for remote, automatic operation.)
3. Relay **K7** powers relays **K2** and **K3**.
4. Relay **K2** powers the engine gauges and terminal **TB1-10**, to which the fuel solenoid is connected.
5. Relay **K3** powers terminal **TB1-8** to which either starter relay **K4** or B1-SW is connected. Engine cranking begins.
6. The engine starts and runs up to governed speed in a matter of seconds.
7. The starter is disconnected when engine speed gets to about 600 RPM. This is done by relay **K10** or **K14**, whichever acts first to open the circuit powering relay **K3**.
8. Relay **K10** is powered by the generator output voltage (120 VAC) through plug-in connectors **P1-1** and **P1-2**. The remote **Run** indicator lamp should light (connected through terminal **TB1-3**).
9. Relay **K14** is powered by the engine-driven battery charging alternator (12 VDC) through plug-in connector **P1-3**. The panel **Run** indicator lamp should light. Relays **K10** and **K14** are redundant.

If the starter disconnects normally but neither the panel nor the remote Run indicator lamps light, the AC (K10) starter disconnect circuit is not working.

Both the remote and the panel Run indicator lamps will light even if the DC (K14) starter

disconnect circuit is not working. Check the DC voltmeter to determine whether or not the battery charging alternator is working.

10. Relays **K2** and **K3** are deenergized (by latching relay **K6**) causing shutdown to occur if the engine does not start within 75 seconds. The **Overcrank** indicator lamp and switch S11 lamp will light and common alarm terminal **TB1-4** is powered.

The ECM has a cycle crank feature whereby the engine is cranked for three 15 second periods alternated with two 15 second rest periods.

11. Relay **K3** is de-energized (by latching relay **K6**) causing shutdown to occur during operation when a low oil pressure, high engine temperature or engine overspeed condition is sensed or the optional emergency stop button is pressed. The appropriate fault indicator lamp lights and common alarm terminal **TB1-4** is powered. (There is no fault lamp for emergency stop. The switch button will light, however, and the light in switch S11.)

The low oil pressure and high engine temperature shutdowns have 10 second time delays to allow oil pressure and engine temperature to stabilize during startup. The 10 second time delay begins after K10 or K14 is energized.

12. To restore operation after a shutdown fault has been serviced, reset latching relay **K6** by pushing the panel **Stop** switch and then the **Reset** switch. The set should run or be ready to run when the panel switch is pushed to **Run** or to **Remote**.

If the emergency stop switch has been used, the control will have to be reset to restore operation. First pull the emergency stop switch button and then push the panel Stop and Reset switches.

13. The set is stopped manually by pressing the panel **Stop** switch or automatically by a remote controller. (The panel switch must be in the **Remote** position for remote, automatic operation.)

4. Troubleshooting

These troubleshooting charts are designed to help you diagnose generator set problems. To save time troubleshooting, read the entire manual ahead of time to understand the generator set. Go over the options and modifications and review what was

done during the last service call. Look the generator set over for any obvious problems. The problem could be as simple as an empty fuel tank, closed fuel shutoff valve, loose wire, blown fuse or tripped circuit breaker.

THE ENGINE DOES NOT CRANK IN RUN MODE

⚠ WARNING *Hazards present in troubleshooting can cause equipment damage, severe personal injury or death. Only trained and experienced service personnel with knowledge of fuels, electricity, and machinery hazards should perform service procedures. Read Safety Precautions page and observe all instructions and precautions in this manual.*

Possible Cause	Corrective Action
1. The Emergency Stop switch has been used. (The switch button is lit.)	Pull the Emergency Switch button. To reset the engine control, push the Run-Stop-Remote switch to Stop and the Reset switch to Reset . Then push the Run-Stop-Remote switch to Run to start the genset.
2. A Fault Shutdown is being indicated by one of the red lights on the control panel.	Service the set as necessary. To reset the engine control, push the Run-Stop-Remote switch to Stop and the Reset switch to Reset . Then push the Run-Stop-Remote switch to Run to start the genset.
3. Cranking voltage is too low to crank the engine.	<ol style="list-style-type: none"> Clean and tighten or replace the positive (+) and negative (-) battery cable connectors and cables at the battery and the set. Recharge or replace the battery. Specific gravity for a fully charged battery is approximately 1.260 at 80° F (27° C). If the set is in standby service, install a battery charger. Replace the engine-driven battery charging alternator if normal battery charging voltage (12 to 14 VDC) is not obtained.
4. Fuse F1 (see Figure 3-4) on ECM has blown (no voltage [B+] at ECM TB1-8).	The wire between ECM TB1-8 and K4-85 may be loose and shorting to ground. Repair as necessary and replace the fuse with one of the same type and amp rating (20 A). If fuse continues to blow, service or replace the starter, relay K4 .
5. The wire between ECM TB1-9 , K4 and starter terminal BAT is loose damaged or missing.	Check for battery voltage (12 VDC) between ECM TB1-9 (B+) and the grounding stud (-) on the floor of the control cabinet. Check, clean and tighten the connectors at both ends and replace the wire if it is damaged.

THE ENGINE DOES NOT CRANK IN RUN MODE (CONT.)

⚠ WARNING *Hazards present in troubleshooting can cause equipment damage, severe personal injury or death. Only trained and experienced service personnel with knowledge of fuels, electricity, and machinery hazards should perform service procedures. Read Safety Precautions page and observe all instructions and precautions in this manual.*

Possible Cause	Corrective Action
6. The grounding strap between the control box and the battery negative (-) terminal or the ground wire between the control and engine ground is loose, damaged or missing.	Check for continuity (zero ohms) between the grounding stud on the bottom of the control box and the battery negative (-) terminal. If there is no continuity or the grounding strap is loose or damaged, repair as necessary.
7. The Run-Stop-Remote switch (S12) or wiring is faulty.	<p>a. Disconnect pin connector J4 from the ECM and check for electrical continuity (zero ohms) between switch terminals 2 and 3 when the switch is in the Run position and between terminals 1 and 2 when it is in the Remote position. Replace the switch if either set of contacts is faulty.</p> <p>b. If the switch works, check for electrical continuity (zero ohms) between J4-6 and J4-7 on the wire harness when the switch is in the Run position and between J4-5 and J4-7 when the switch is in the Remote position. Repair the wire harness if there is no electrical continuity in either position of the switch.</p>
8. The wire between ECM TB1-8 , K4 and starter solenoid terminal SW is loose, damaged or missing.	Push the Run-Stop-Remote switch to Run and check for battery voltage (12 VDC) at starter solenoid terminal SW . If there is no voltage repair the wiring as necessary.
9. The starter motor or solenoid is malfunctioning.	Push the Run-Stop-Remote switch to Run and check for battery voltage (B+) at starter solenoid terminal SW . Replace the starter motor if there is voltage but the motor does not function.
10. The Time Delay Start/Stop Module (A15) is malfunctioning.	Check for constant B+ at A15 terminal TB1-4 . Check for run signal at ECM TB1-6 . Voltage at A15 TB1-6 should be at B+ at the end of the start delay period. Check wiring and connections from A15 TB1-6 to ECM TB1-6 .
11. ECM is faulty. (Check fuses F1 and F4 and for B+ at TB1-9 again.)	Push the Run-Stop-Remote switch to Run and check for battery voltage (12 VDC) at ECM TB1-8 . Replace ECM if there is no voltage at ECM TB1-8 but 12 VDC at ECM TB1-9 .

THE ENGINE DOES NOT CRANK IN REMOTE MODE

⚠ WARNING *Hazards present in troubleshooting can cause equipment damage, severe personal injury or death. Only trained and experienced service personnel with knowledge of fuels, electricity, and machinery hazards should perform service procedures. Read Safety Precautions page and observe all instructions and precautions in this manual.*

Possible Cause	Corrective Action
1. The Run-Stop-Remote switch is at Stop . (The Switch-Off light will be flashing.)	Push the Run-Stop-Remote switch to Remote .
2. The Emergency Stop switch has been used. (The switch button is lit.)	Pull the Emergency Switch button. To reset the engine control, push the Run-Stop-Remote switch to Stop and the Reset switch to Reset . Then push the Run-Stop-Remote switch to Remote .
3. A Fault Shutdown is being indicated by one of the red lights on the control panel.	Service the set as necessary. To reset the engine control, push the Run-Stop-Remote switch to Stop and the Reset switch to Reset . Then push the Run-Stop-Remote switch to Remote .
4. There is no remote circuit signal (12 VDC at auxiliary relay board A28-TB1-6) because fuse F3 on the ECM has blown.	<ol style="list-style-type: none"> a. Replace the fuse with one of the same type and amp rating (15 A). b. If fuse F3 blows again, find and repair the fault in the remote control circuit, such as a loose wire that may be shorting to ground or a shorted relay coil or other component. See <i>Section 7</i> for remote connections.
5. There is no remote circuit signal (12 VDC at auxiliary relay board A28-TB1-6) because the remote circuit is not functioning properly.	Apply 12 VDC to A28-TB1-6 . If the engine cranks, find and repair the fault in the remote control circuit. See <i>Section 7</i> for remote connections.
6. Auxiliary relay board A28 is not functioning properly.	Check for misconnections (see <i>Section 7</i>) or loose connections and replace auxiliary relay board A28 if there is 12 VDC at terminal A28-TB1-6 but not at A28-J2-6 .
7. Same as Steps 3 through 11 in the RUN mode.	See steps 3 through 11 in table <i>Engine Does Not Crank In Run Mode</i> .

THE ENGINE CRANKS BUT DOES NOT START

⚠ WARNING Hazards present in troubleshooting can cause equipment damage, severe personal injury or death. Only trained and experienced service personnel with knowledge of fuels, electricity, and machinery hazards should perform service procedures. Read Safety Precautions page and observe all instructions and precautions in this manual.

Possible Cause	Corrective Action
1. The engine is not getting fuel.	<p>a. Open any closed fuel shutoff valve. (Valves closed for maintenance or new installations may require several crank cycles to get fuel to genset.)</p> <p>b. Fill the propane supply tank.</p> <p>c. For natural gas fueled sets, check with the gas utility.</p> <p>d. Check fuel pressure at regulator (refer to <i>Fuel Pressure</i> in <i>Section 6</i>.) (High fuel pressure will prevent solenoid from opening.)</p> <p>e. Check fuel solenoid (VDC present at K1+ lead during cranking).</p> <p>Duel Fuel Sets Only:</p> <p>f. Check relay K99. Refer to wiring diagrams in <i>Section 7</i>.</p> <p>g. Check pressure switch wiring. Propane – normally closed connected to common. Natural gas – normally open connected to common.</p> <p>h. Check pressure switch function (@ 3.5 inch H₂O or less, should switch from natural gas to LPG).</p> <p>i. Check S14 vacuum switch (optional) for proper operation.</p>
2. The air cleaner is blocked.	Service as necessary.
3. Fuse F2 on the ECM has blown.	Replace fuse with one of the same type and amp rating. If fuse F2 blows again, the wire between ECM TB1-10 and engine block terminal T26 , or a wire between terminal T26 and an accessory may be loose or shorting to ground.
4. Fuel solenoid K1 does not energize.	<p>a. Fuel solenoid not energized by the ECM. Check for B+ at ECM TB1-10 when cranking. If no voltage present and fuse F2 is good replace ECM.</p> <p>b. Connect B+ to fuel solenoid (K1) terminal BAT. Replace the fuel solenoid if does not “click” when energized. If fuel solenoid is working, check for blocked fuel line or fuel filter.</p>
5. Low engine temperature is causing too low a cranking speed for starting.	<p>a. Increase room temperature.</p> <p>b. Plug in, repair or install engine coolant heater.</p> <p>c. Replace the engine oil if it is not of the recommended viscosity for the ambient temperature.</p>

THE ENGINE CRANKS BUT DOES NOT START (CONT.)

⚠ WARNING *Hazards present in troubleshooting can cause equipment damage, severe personal injury or death. Only trained and experienced service personnel with knowledge of fuels, electricity, and machinery hazards should perform service procedures. Read Safety Precautions page and observe all instructions and precautions in this manual.*

Possible Cause	Corrective Action
6. Cranking voltage is too low to reach required cranking speed.	<ul style="list-style-type: none"> a. While cranking the engine, measure voltage directly across the battery terminals and then immediately across the starter motor terminal and the grounding bolt on the block. Cable, terminal or relay contact resistance is too high if the difference is more than 2 volts. Service as necessary. b. Recharge or replace the battery. Specific gravity for a fully charged battery is approximately 1.260 at 80° F (27° C). c. Replace the engine-driven battery charging alternator if normal battery charging voltage is not between 12 and 14 volts.
7. Governor inoperable. Type A or B , see <i>Section 6</i> .	Replace governor.
8. The engine ignition system is malfunctioning. Refer to wiring diagrams in <i>Section 7</i> .	<p>V6 Engine:</p> <ul style="list-style-type: none"> a. Check for battery VDC at coil while cranking. (Red wire with green stripe.) b. Spec C – Check Ford engine harness ground lead connection. c. Spec C – Check 10 amp fuse located on Ford engine harness power block. d. Check crank position sensor (315 to 385 ohms). e. Check ignition coil (0.5 to 1.3 ohms). f. Replace ignition module if above items are OK. <p>V10 Engine:</p> <ul style="list-style-type: none"> a. Check for battery VDC at ignitor coil while cranking. (Red wire with green stripe.) b. Spec D – Check three fuses located on Ford engine harness power block. c. Spec D – Check B+ power connection of Ford engine harness power lead (starter motor stud – B1). b. Check crank position sensor (315 to 385 ohms). c. Check cam position sensor (315 to 385 ohms). d. Check ignition coil primary (0.5 to 1.3 ohms). e. Replace ignition module if above items are OK.
9. The magnetic speed pick-up is defective or requires adjustment.	Refer to <i>Magnetic Speed Pickup Unit Adjustment</i> in <i>Section 6</i> .

THE ENGINE CRANKS BUT DOES NOT START (CONT.)

⚠ WARNING *Hazards present in troubleshooting can cause equipment damage, severe personal injury or death. Only trained and experienced service personnel with knowledge of fuels, electricity, and machinery hazards should perform service procedures. Read Safety Precautions page and observe all instructions and precautions in this manual.*

Possible Cause	Corrective Action
10. Incorrect main fuel valve adjustment.	Refer to <i>Gaseous Fuel Adjustment (Type A or B)</i> in Section 6.
11. Incorrect secondary regulator adjustment.	Refer to <i>Initial Secondary Regulator Adjustment</i> in Section 6.

THE ENGINE RUNS UNTIL FAULT SHUTDOWN

⚠ WARNING *Hazards present in troubleshooting can cause equipment damage, severe personal injury or death. Only trained and experienced service personnel with knowledge of fuels, electricity, and machinery hazards should perform service procedures. Read Safety Precautions page and observe all instructions and precautions in this manual.*

Possible Cause	Corrective Action
1. The OVERSPEED lamp comes on and the engine shuts down.	<ul style="list-style-type: none"> a. Reset the ECM by pushing the Run-Stop-Remote switch to Stop and the Reset switch to Reset and restart the set, monitoring engine speed. b. Adjust the governor for Type A fuel system/check operation of Type B integrated governor (see <i>Section 6</i>). c. Type A: If the governor cannot be adjusted to prevent shutdown due to overspeed, check for binding in the linkage. Repair and adjust the linkage as necessary. d. Type A and B: If the set still shuts down due to overspeed, re-install the magnetic speed pick-up unit to make sure the clearance with the flywheel gear teeth is correct (see <i>Section 6</i>). Replace the speed-pickup unit if output voltage at cranking speed is less than 1.5 VAC. (Intermittent open on magnetic speed pick-up lead can also cause an overspeed condition.) e. Replace the governor controller board (Type A) or integrated governor assembly (Type B) if the set still shuts down due to overspeed.
2a. The OVERSPEED lamp comes on and the engine shuts down within 1 to 5 seconds (no overspeed condition detected). (V6 Spec A & B, V10 Spec A-C)	<ul style="list-style-type: none"> a. Remove K5-30 lead from K5. Start genset. If set shuts down and overspeed light is on, replace ECM (A11). b. Remove K5-30 lead from K5 and check lead continuity to ground. If ground present, replace ignition module. c. Connect K5-30. Remove lead K5-87 and check lead continuity to ground. If ground present, replace K5 relay. d. Remove K5-87 lead from K5 and start genset. If set shuts down and OVERSPEED lamp comes on, replace ECM (A11). e. Check Ford engine harness oil pressure lead for proper ground to intake manifold. Must be grounded to prevent false ignition module fault.
2b. The OVERSPEED lamp comes on and the engine shuts down within 1 to 5 seconds (no overspeed condition detected). (V6 Spec C)	<ul style="list-style-type: none"> f. Remove connector from J2 of the ECM (A11) board and check pin J2-6 continuity to ground. If ground present, replace ignition module. g. Check Ford engine harness oil pressure lead for proper ground to intake manifold. Must be grounded to prevent false ignition module fault.

THE ENGINE RUNS UNTIL FAULT SHUTDOWN (CONT.)

⚠ WARNING Hazards present in troubleshooting can cause equipment damage, severe personal injury or death. Only trained and experienced service personnel with knowledge of fuels, electricity, and machinery hazards should perform service procedures. Read Safety Precautions page and observe all instructions and precautions in this manual.

Possible Cause	Corrective Action
3. The OVERSPEED lamp comes on and the engine shuts down after 1 or more minutes (no over-speed condition detected).	<ul style="list-style-type: none"> a. Low coolant. Fill cooling system. b. Air in cooling system. Bleed cooling system. c. Remove plug from engine cylinder switch. Start genset. If no fault, switch is defective. (This switch is not used by the control, but can cause fault condition if defective.)
4. The LO OIL PRES lamp comes on and the engine shuts down within 10 to 15 seconds (Over-speed lamp is off).	<ul style="list-style-type: none"> a. Check the engine oil level, repair any oil leaks and fill to the proper level. Then reset the ECM by pushing the Run-Stop-Remote switch to Stop and the Reset switch to Reset. b. If the set still shuts down due to low oil pressure, restart the set and observe oil pressure while cranking the engine. Service the lubricating oil system according to the engine service manual if oil pressure is less than 25 psi (173 kPa). c. If engine oil pressure is proven to be correct and the set still shuts down due to low oil pressure, replace the low oil pressure sender. See <i>Section 3</i> to locate the sender. d. Defective Sensor (A27) board. Remove plug from A27 and start set. If set continues to run, replace A27. Refer to <i>Section 3</i> for A27 board connections. e. Check S14 vacuum switch (optional) for proper operation.
5. The LO OIL PRES lamp comes on and the engine shuts down after 1 or more minutes (Over-speed lamp is off).	<ul style="list-style-type: none"> a. See step 4 in this table. b. See steps 1, 8 and 9 in table Engine Cranks But Does Not Start.

THE ENGINE RUNS UNTIL FAULT SHUTDOWN (CONT.)

⚠ WARNING Hazards present in troubleshooting can cause equipment damage, severe personal injury or death. Only trained and experienced service personnel with knowledge of fuels, electricity, and machinery hazards should perform service procedures. Read Safety Precautions page and observe all instructions and precautions in this manual.

Possible Cause	Corrective Action
<p>6. The HI ENG TEMP lamp comes on and the engine shuts down.</p>	<ul style="list-style-type: none"> a. Check the engine coolant level, repair any coolant leaks and refill as necessary. Then reset the ECM by pushing the Run-Stop-Remote switch to Stop and the Reset switch to Reset. b. If the set still shuts down due to high engine temperature, start the engine and observe coolant temperature as the system heats up. If coolant temperature exceeds 230° F (110° C), clean and service the entire cooling system as required to restore full cooling capacity. c. If shutdown occurs before the coolant reaches 230° F (110° C), replace temperature sender if the voltage across the sender terminals is less than 1.1 VDC. See <i>Section 3</i> to locate the temperature sender. d. Defective Sensor board. Refer to <i>Section 3</i> for Sensor board connections. e. Defective engine thermostat. Service the engine according to the engine service manual.
<p>7. The FAULT 1 or FAULT 2 lamp comes on and the engine shuts down.</p>	<p>Service as required. (The customer has supplied the system fault indication switches. Either fault can be chosen to display the warning only. See <i>Section 3</i>.)</p> <p>If the shutdown was due to low frequency, the set probably ran out of fuel or the governor is out of adjustment.</p> <p>If the shutdown was due to over/under voltage, the voltage regulator may be out of adjustment.</p>

THE ENGINE LACKS POWER OR IS UNSTABLE

⚠ WARNING *Hazards present in troubleshooting can cause equipment damage, severe personal injury or death. Only trained and experienced service personnel with knowledge of fuels, electricity, and machinery hazards should perform service procedures. Read Safety Precautions page and observe all instructions and precautions in this manual.*

Possible Cause	Corrective Action
1. Current ambient conditions cause a derate, limiting power to less than rated power.	Determine proper derates for ambient conditions. Refer to specification sheet for site derating factors.
2. The engine air filter element is dirty.	Replace the air filter element.
3. The gaseous fuel is of insufficient energy content.	Check with the propane supplier or the gas utility to confirm the energy content of the gaseous fuel being used. Propane must have approximately 2500 BTU's per cubic foot and natural gas 1000 BTU's per cubic foot.
4. LPG liquid converter frosts.	<ul style="list-style-type: none"> a. Low coolant. Fill cooling system. b. Air in cooling system. Bleed cooling system.
5. The governor or gas mixer adjustments are incorrect.	<ul style="list-style-type: none"> a. Make gas mixer or governor settings and adjustments for Type A and B fuel systems according to <i>Section 6, Governor</i>. b. Check the magnetic speed pick-up unit (MPU) clearance with flywheel. Replace the MPU if output voltage at cranking speed is less than 1.5 VAC. c. Type A: If the governor cannot be adjusted for full power or stable speed, shut down the set and check for binding in the linkage. Repair and adjust the linkage as necessary. d. Type B: With the genset off, connect lead marked ALT DYN to lead marked T26 at governor. If governor stability is OK, leave connection. e. Type A: Replace the governor controller board. Type B: Replace the integrated governor assembly.

THE ENGINE LACKS POWER OR IS UNSTABLE (CONT.)

⚠ WARNING *Hazards present in troubleshooting can cause equipment damage, severe personal injury or death. Only trained and experienced service personnel with knowledge of fuels, electricity, and machinery hazards should perform service procedures. Read Safety Precautions page and observe all instructions and precautions in this manual.*

Possible Cause	Corrective Action
6. Engine hunting at 90% to 100% of full load.	<ul style="list-style-type: none"> a. Type B: This governor is equipped with a adaptive feature, which can affect the operation of the genset. If the genset was hunting excessively prior to attempting full load operation, the lower gain value may affect full load operation and transient performance. Stopping and restarting the genset will return the gain values to normal. b. Type B: No Air/Fuel adjustment available – check K99 wiring (see Section 7). K99 relay, miswired, can cause genset hunting.) c. Type A and B – See step 5 of this table.
7. Engine misfires on LPG or NG or backfires on LPG at high loads	<ul style="list-style-type: none"> a. Air fuel ratio too lean. Adjust main fuel valve. Refer to <i>Gaseous Fuel Adjustment (Type A or B)</i> in Section 6. b. Inspect spark plugs/gap. GGFD, GGFE, GGEH GGHF = 0.044" / GGHG, GGHH = 0.032. c. Check spark plug wires (6,000 ohms/foot). d. Check ignition coil primary (0.5 to 1.3 ohms). e. LPG liquid withdrawal – defective LPL converter.
8. Engine has preignition on LPG at high loads.	<ul style="list-style-type: none"> a. Check ignition timing, refer to Section 6.
9. Gaseous fuel delivery (vapor withdrawal) to the set is inadequate or fuel pressure is to high at light loads.	Check the gas supply pressure at the regulator input. Make necessary provisions so that gas supply pressure is at least 7 inches (178 mm) Water Column (WC) when the set is under full load, and not more than 13.6 inches (345 mm) WC.
10. The MAP sensor is defective (V10 turbo only).	Check operation of MAP sensor, refer to Section 3.
11. Excessive crank time before starting (LPG liquid withdrawal fuel systems with Impco Model E convertor).	Check operation of K1-SV converter priming solenoid. Remove black cover and visually check solenoid operation during cranking.

THE ENGINE LACKS POWER OR IS UNSTABLE (CONT.)

⚠ WARNING *Hazards present in troubleshooting can cause equipment damage, severe personal injury or death. Only trained and experienced service personnel with knowledge of fuels, electricity, and machinery hazards should perform service procedures. Read Safety Precautions page and observe all instructions and precautions in this manual.*

Possible Cause	Corrective Action
12. Excessive crank time (seven seconds or more) before starting (NG or LPG vapor)	a. See step 9 in this table. b. Regulator (model RZ) may require adjustment. Refer to <i>Initial Secondary Regulator Adjustment</i> in Section 6.
13. The engine is worn.	Service the engine according to the engine service manual.

AN AMBER WARNING LAMP IS ON

⚠ WARNING Hazards present in troubleshooting can cause equipment damage, severe personal injury or death. Only trained and experienced service personnel with knowledge of fuels, electricity, and machinery hazards should perform service procedures. Read Safety Precautions page and observe all instructions and precautions in this manual.

Possible Cause	Corrective Action
1. The PRE LO OIL PRES lamp comes on while the engine is running.	<p>a. Shut down the set if possible or disconnect non-critical loads. Pre lo oil pressure will be less than 30 psi (207 kPa) but greater than 25 psi (173 kPa). Service the engine lubricating system according to the engine service manual.</p> <p>b. If engine oil pressure is proven to be correct and the pre lo oil pressure lamp is on, the problem may be the Sensor board or the oil pressure sender. Refer to <i>Section 3</i> for Sensor board connections.</p>
2. The PRE HI ENG TEMP lamp comes on while the engine is running.	<p>a. Shut down the set if possible or disconnect non-critical loads. (Engine temperature will be greater than 220° F (104° C) but less than 230° F [110° C.]) Service the engine cooling system to restore full cooling capacity.</p> <p>b. If the engine cooling system is functioning properly, the problem may be the Sensor board. Refer to <i>Section 3</i> for Sensor board connections.</p>
3. The LOW ENGINE TEMPERATURE lamp comes on while the set is in standby.	<p>a. Plug in, repair or install engine coolant heater.</p> <p>b. If engine coolant heater is operating properly, the problem may be the Sensor board. Refer to <i>Section 3</i> for Sensor board connections.</p>
4. The LOW FUEL lamp (optional) comes on while the set is in standby or the engine is running.	<p>a. Indicates fuel supply pressure is 5 inches (127 mm) WC or less for dual or single fuel systems. With dual fuel system, also indicates that genset is operating on secondary fuel supply. Fill the propane supply tank or for natural gas fueled sets, check with the gas utility.</p> <p>Dual Fuel Systems:</p> <p>b. Check operation/wiring of fuel pressure switch (S11).</p> <p>c. Check operation/wiring of K99 relay.</p>
5. The FAULT 1 or FAULT 2 lamp (may be a specifically labeled amber lamp) comes on.	Service as required. (The customer has supplied the system fault indicating switches. By means of selection jumpers, either fault may be chosen to shut down the engine. See <i>Section 3, Engine Control</i> .)

LOW EMISSIONS GENSET ONLY

⚠ WARNING *Hazards present in troubleshooting can cause equipment damage, severe personal injury or death. Only trained and experienced service personnel with knowledge of fuels, electricity, and machinery hazards should perform service procedures. Read Safety Precautions page and observe all instructions and precautions in this manual.*

Possible Cause

Corrective Action

NOTE: This table applies only to the low emissions genset (integrated governor).

<p>1. The CHECK ENGINE lamp comes on at no load.</p>	<p>a. This is normal during no load, cold ambient condition. Increase genset load to 10% or more, lamp should turn off. To verify system operation, disconnect O2 sensor and reconnect after 1 minute. Genset speed will change slightly (air fuel ratio will go lean momentarily) indicating system is working properly.</p>
<p>2. The CHECK ENGINE lamp comes on at 10% or less loads.</p>	<p>a. Engine not at operating temperature. Lamp should extinguish after approximately 3 1/2 minutes. b. Unstable governor. See step 1 in table Engine runs Until Fault Shutdown. c. Incorrect gas pressure or secondary regulator needs adjustment. See step 12 of Engine Lacks Power or is Unstable. d. O2 sensor defective. Replace if heater cold resistance is not 2.1±.4 ohms or sensor is not approximately 1k ohms new/1.5k ohms old. e. Replace the automatic main fuel valve.</p>
<p>3. The CHECK ENGINE lamp comes on at 10% or higher loads</p>	<p>a. Incorrect gas pressure. See step 9 of Engine Lacks Power or is Unstable. b. Unstable governor. See step 1 of Engine Runs Until Fault Shutdown. c. Excessively high exhaust back pressure. Refer to Installation manual. d. O2 sensor defective. Replace if heater cold resistance is not 2.1±.4 ohms or sensor is not approximately 1k ohms new/1.5k ohms old.</p>
<p>4. Mild hunting at 0 to 50% load.</p>	<p>a. Unstable fuel control. Disconnect O2 sensor. If hunting stops, replace the automatic main fuel valve. Replace the integrated governor assembly if hunting does not stop.</p>

LOW EMISSIONS GENSET ONLY (CONT.)

⚠ WARNING *Hazards present in troubleshooting can cause equipment damage, severe personal injury or death. Only trained and experienced service personnel with knowledge of fuels, electricity, and machinery hazards should perform service procedures. Read Safety Precautions page and observe all instructions and precautions in this manual.*

Possible Cause	Corrective Action
5. The CHECK ENGINE lamp comes on momentarily during load increase.	a. Incorrect gas pressure at full load. See step 9 of Engine Lacks Power or is Unstable . b. Replace the automatic main fuel valve.
6. The CHECK ENGINE lamp comes on momentarily during load decrease.	a. Incorrect gas pressure at 0% load. See step 9 of Engine Lacks Power or is Unstable . b. Replace the automatic main fuel valve.

THE GREEN RUN LAMP STAYS OFF BUT THE SET RUNS NORMALLY

⚠ WARNING *Hazards present in troubleshooting can cause equipment damage, severe personal injury or death. Only trained and experienced service personnel with knowledge of fuels, electricity, and machinery hazards should perform service procedures. Read Safety Precautions page and observe all instructions and precautions in this manual.*

Possible Cause	Corrective Action
<p>1. The set mounted RUN lamp does not light, although the starter has disconnected normally and the engine is running. The remote RUN lamp does light (AC start disconnect is okay).</p>	<p>a. Press the panel Lamp Test switch and replace the run lamp bulb if it does not light.</p> <p>b. If the RUN lamp, wiring connections and battery charging alternator are all good and the RUN lamp does not light, replace the ECM.</p>
<p>2. Both the remote and set mounted RUN lamps do not light, although the starter has disconnected normally and the engine is running.</p>	<p>a. Press the panel Lamp Test switch and replace the run lamp bulb if it does not light. Test the remote RUN lamp by suitable means and replace it if it does not light.</p> <p>b. If both lamps are good, this indicates that the AC disconnect circuit is not working. Check the AC voltmeter to determine whether or not there is generator output voltage and service as necessary. See <i>There Is No Output Voltage in Troubleshooting</i>.</p> <p>c. If there is generator output voltage, check for 120 VAC across pin connectors P1-1 and P1-2 on the ECM. If there is no voltage, check for loose or missing leads between the connectors and TB21-21 and TB21-32 inside the control box and service as necessary.</p> <p>d. Replace the ECM if there is 120 VAC across pin connectors P1-1 and P1-2 but neither RUN lamp lights during normal operation.</p>

NO OUTPUT VOLTAGE

⚠ WARNING Hazards present in troubleshooting can cause equipment damage, severe personal injury or death. Only trained and experienced service personnel with knowledge of fuels, electricity, and machinery hazards should perform service procedures. Read Safety Precautions page and observe all instructions and precautions in this manual.

Possible Cause	Corrective Action
1. The line circuit breaker is OFF .	Find out why the circuit breaker was turned OFF , make sure it is safe to reconnect power, and then throw the circuit breaker ON .
2. The line circuit breaker has TRIPPED .	Shut down the set and service as necessary to clear the short circuit or ground fault that caused tripping, and then RESET the circuit breaker and start the set.
3. The line circuit breaker is faulty.	Shut down the set, make sure the power output lines from the set have been disconnected from all other sources of power, attempt to RESET the circuit breaker and throw it ON and check for electrical continuity across each line contact. Replace the circuit breaker if there is measurable resistance across any contact.
4. Field circuit breaker CB21 has TRIPPED .	RESET the circuit breaker. If it keeps tripping, troubleshoot according to the chart, <i>Field Circuit Breaker Keeps Tripping</i> .
5. Field circuit breaker CB21 is faulty.	Shut down the set, attempt to RESET the circuit breaker and disconnect either lead. Replace the circuit breaker if there is measurable resistance across the terminals.

NO OUTPUT VOLTAGE (CONT.)

⚠ WARNING *Hazards present in troubleshooting can cause equipment damage, severe personal injury or death. Only trained and experienced service personnel with knowledge of fuels, electricity, and machinery hazards should perform service procedures. Read Safety Precautions page and observe all instructions and precautions in this manual.*

Possible Cause

Corrective Action

Determine if the problem is in the voltage regulating or generator circuits as follows:

- a. Throw the line circuit breaker **OFF** and shut down the set.

⚠ CAUTION *This test involves unregulated excitation of the generator. To prevent damage to the generator due to overcurrent, make sure that all loads have been disconnected and that all faults have been cleared from the power output terminals of the generator.*

- b. Open the control panel and disconnect the field leads **X (F1)** and **XX (F2)** from the voltage regulator. See Figure 2-4. Perform the exciter stator winding resistance test (*Section 7*). The exciter stator resistance must test okay before proceeding.
- c. Prepare to measure output voltage across the generator terminals while the set is running.
- d. Bring two jumpers from a **12 volt battery** for connection to the **X (F1)** and **XX (F2)** leads inside the control box. Connect the jumper from the positive (+) post of the battery to the **F1 (X)** lead. Be prepared to connect the jumper from the negative (-) post of the battery to the **XX (F2)** lead.
- e. Check polarity again. Polarity must be correct or this test will be inconclusive because the induced and residual magnetic polarities in the exciter stator will be opposed.

⚠ DANGER *HIGH VOLTAGE. Touching uninsulated high voltage parts inside the control box can result in severe personal injury or death. Measurements and adjustments must be done with care to avoid touching high voltage parts. For your protection, stand on a dry wooden platform or rubber insulating mat, make sure your clothing and shoes are dry, remove jewelry from your hands and wear elbow length insulating gloves.*

- f. Start the set and connect the jumper wire from the battery negative (-) terminal to the **XX (F2)** lead.
- g. The generator is probably okay if rated output voltage or higher is obtained and the voltages for all phases are balanced when the exciter is powered by the 12 volt battery. Refer to the Voltage Regulator fault chart (step 6 or 7) for troubleshooting. (Normal excitation voltage ranges approximately from 10 VDC at no-load to 40 VDC at full-load.)
- h. Use the following Generator fault charts if the output voltages are not balanced, or are less than ninety percent of rated output voltage. If the voltages are unbalanced, first troubleshoot the main stator—Step 12, If the voltages are uniformly low, first troubleshoot the exciter and field circuits—Steps 8, 9, 10 and 11.

6. Voltage regulating faults (**PMG-excited generators**).

- a. Follow the PMG test described in *Section 7* to determine if it is okay.
- b. Check all connections against the applicable reconnection diagram (*Section 9*) and rewire as necessary. Replace the voltage regulator if the PMG checks okay, the wiring is correct and there is no output voltage.

⚠ CAUTION *Replacing the voltage regulator before servicing other faults can lead to damage to the new voltage regulator.*

NO OUTPUT VOLTAGE (CONT.)

⚠ WARNING *Hazards present in troubleshooting can cause equipment damage, severe personal injury or death. Only trained and experienced service personnel with knowledge of fuels, electricity, and machinery hazards should perform service procedures. Read Safety Precautions page and observe all instructions and precautions in this manual.*

Possible Cause	Corrective Action
7. Voltage regulating faults (Shunt-excited generators).	<p>a. Flash the field as described in <i>Section 5</i>.</p> <p>b. Check all connections against the applicable reconnection diagram (<i>Section 7</i>) and rewire as necessary. Replace the voltage regulator if the wiring is correct and there is no output voltage.</p> <p>⚠ CAUTION <i>Replacing the voltage regulator before servicing other faults can lead to damage to the new voltage regulator.</i></p>
8. The exciter field winding is open.	Shut down the set and check exciter field winding resistance according to <i>Section 5</i> . Replace the exciter field assembly if winding resistance does not meet specifications.
9. The rotating rectifier assembly (diodes CR1 through CR6) is faulty.	Shut down the set and check each diode according to <i>Section 5</i> . Service as necessary.
10. The exciter rotor windings are open.	Shut down the set and check exciter winding resistances according to <i>Section 5</i> . Replace the generator rotor assembly if exciter rotor winding resistances do not meet specifications.
11. The main rotor winding is open.	Shut down the set and check main rotor winding resistance according to <i>Section 5</i> . Replace the generator rotor assembly if main rotor winding resistance does not meet specifications.
12. The stator windings are open.	Shut down the set and check stator winding resistances according to <i>Section 5</i> . Replace the generator stator assembly if stator winding resistances do not meet specifications.

OUTPUT VOLTAGE IS TOO HIGH OR TOO LOW

⚠ WARNING *Hazards present in troubleshooting can cause equipment damage, severe personal injury or death. Only trained and experienced service personnel with knowledge of fuels, electricity, and machinery hazards should perform service procedures. Read Safety Precautions page and observe all instructions and precautions in this manual.*

Possible Cause	Corrective Action
1. Engine speed is unstable.	Troubleshoot according to the chart, <i>The Engine Lacks Power or is Unstable</i> .
2. The voltage has been adjusted improperly.	Adjust output voltage according to <i>Section 2, AC Control</i> .
3. Improper connections have been made at the generator output terminals.	Shut down the set and reconnect according to the appropriate reconnection diagram. See <i>Section 7</i> .
4. The rotating rectifier assembly (diodes CR1 through CR6) is faulty.	Shut down the set and check each diode according to <i>Section 5, Servicing the Generator</i> . Service as necessary.
5. Voltage Regulator VR21 is faulty.	Replace the voltage regulator. ⚠ CAUTION <i>Replacing the voltage regulator before servicing other faults can lead to damage to the new voltage regulator.</i>

OUTPUT VOLTAGE IS UNSTABLE

⚠ WARNING *Hazards present in troubleshooting can cause equipment damage, severe personal injury or death. Only trained and experienced service personnel with knowledge of fuels, electricity, and machinery hazards should perform service procedures. Read Safety Precautions page and observe all instructions and precautions in this manual.*

Possible Cause	Corrective Action
1. The voltage has been adjusted improperly.	Adjust output voltage according to <i>Section 2, AC Control</i> .
2. The voltage adjusting rheostat on the control panel is faulty (if provided).	Unlock the voltage adjusting screw on the front of the control panel and disconnect either lead from the rheostat. Measure resistance between terminals 1 and 2 while turning the adjusting screw fully one way and then the other. Replace the rheostat if it is open at any point, or if resistance does not vary smoothly from zero to approximately 1,500 ohms for sets with the SX460 voltage regulator (shunt excited) or 5,000 ohms for sets with the MX321 voltage regulator (PMG-excited).
3. Voltage Regulator VR21 is faulty.	Replace the voltage regulator. ⚠ CAUTION <i>Replacing the voltage regulator before servicing other faults can lead to damage to the new voltage regulator.</i>

THE FIELD CIRCUIT BREAKER KEEPS TRIPPING

⚠ WARNING *Hazards present in troubleshooting can cause equipment damage, severe personal injury or death. Only trained and experienced service personnel with knowledge of fuels, electricity, and machinery hazards should perform service procedures. Read Safety Precautions page and observe all instructions and precautions in this manual.*

Possible Cause	Corrective Action
1. The rotating rectifier assembly (diodes CR1 through CR6) is faulty.	Shut down the set and check each diode according to <i>Section 7</i> . Service as necessary.
2. The exciter field winding is shorted.	Shut down the set and check exciter field winding resistance according to <i>Section 5</i> . Replace the exciter field assembly if winding resistance does not meet specifications.
3. The exciter rotor windings are shorted.	Shut down the set and check exciter winding resistances according to <i>Section 5</i> . Replace the generator rotor assembly if exciter rotor winding resistances do not meet specifications.
4. The main rotor winding is shorted.	Shut down the set and check main rotor winding resistance according to <i>Section 5</i> . Replace the generator rotor assembly if main rotor winding resistance does not meet specifications.
5. The stator windings are shorted.	Shut down the set and check stator winding resistances according to <i>Section 5</i> . Replace the generator stator assembly if stator winding resistances do not meet specifications.
6. Voltage Regulator VR21 is faulty.	Replace the voltage regulator. ⚠ CAUTION <i>Replacing the voltage regulator before servicing other faults can lead to damage to the new voltage regulator.</i>

THE PHASE CURRENTS ARE UNBALANCED

⚠ WARNING Hazards present in troubleshooting can cause equipment damage, severe personal injury or death. Only trained and experienced service personnel with knowledge of fuels, electricity, and machinery hazards should perform service procedures. Read Safety Precautions page and observe all instructions and precautions in this manual.

Possible Cause	Corrective Action
1. The connected loads are distributed unevenly among the phases.	Shut down the set and redistribute the loads as evenly as possible.
2. Improper connections have been made at the generator output terminals.	Shut down the set and reconnect according to the reconnection diagram. See <i>Section 7</i> .
3. The stator windings are faulty (open or shorted).	Shut down the set and check stator winding resistances according to <i>Section 5</i> . Replace the generator stator assembly if stator winding resistances do not meet specifications.
4. A load has a ground fault or short circuit.	Service the faulty equipment as necessary.

THIS PAGE LEFT INTENTIONALLY BLANK

5. Servicing the Generator

TESTING THE GENERATOR

These tests can be performed without removing the generator. Before starting tests, disconnect the starting battery cables (negative [-] first) to make sure the engine will not start while performing these tests.

⚠️ WARNING Ignition of explosive battery gases can cause severe personal injury. Arcing at battery terminals, light switch or other equipment, flame, pilot lights and sparks can ignite battery gas. Do not smoke, or switch trouble light ON or OFF near battery. Discharge static electricity from body before touching batteries by first touching a grounded metal surface.

Ventilate battery area before working on or near battery—Wear goggles—Stop genset and disconnect charger before disconnecting battery cables—Disconnect negative (-) cable first and reconnect last.

⚠️ CAUTION Disconnect battery charger from AC source before disconnecting battery cables. Otherwise, disconnecting cables can result in voltage spikes damaging to DC control circuits of the set.

⚠️ WARNING Accidental starting of the generator set can cause severe personal injury or death. Prevent accidental starting by disconnecting the negative (-) cable from the battery terminal.

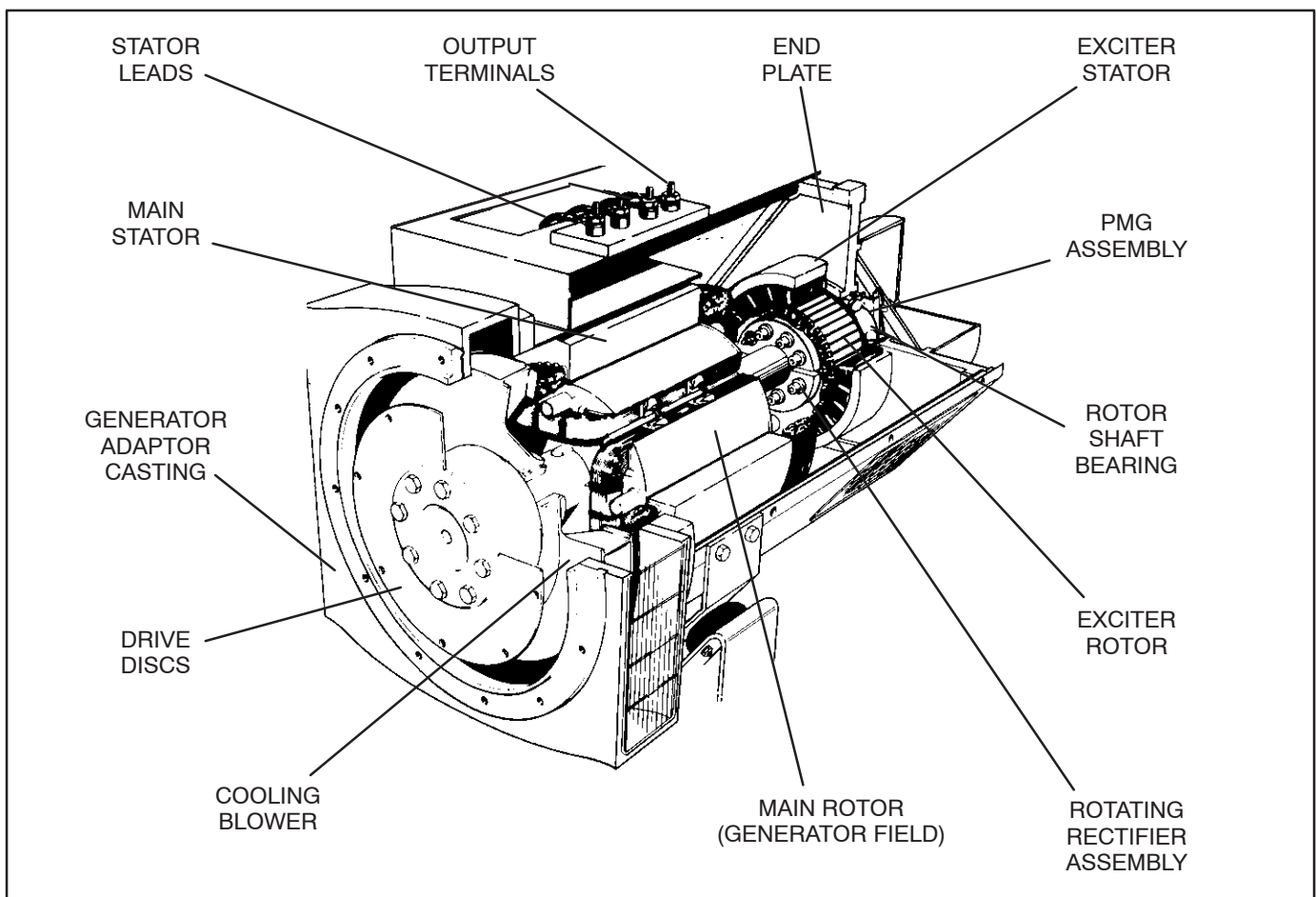

FIGURE 5-1. GENERATOR

Exciter Stator

Testing Winding Resistance: Measure winding resistance with a Wheatstone bridge or digital ohmmeter. Replace the stator if winding resistance is not as specified by Table 5-1.

Testing Winding Insulation Resistance: Disconnect the exciter stator leads from terminals **X** and **XX** on the auxiliary terminal board in the generator output box. Using an ohmmeter, measure resistance between either lead and the stator laminations. Replace the stator if insulation resistance is less than 1 megohm (1,000,000 ohms)

Flashing the Field (Self-Excited Generators Only): If necessary, flash the exciter field before or after installation. Apply 110 to 220 VAC for one to two seconds to the **X** and **XX** leads of the exciter stator. **The generator must be shut down, the AVR disconnected, a diode used to establish correct polarity and a 3 amp fuse to prevent over-excitation.** See the diagram.

Alternatively, while the set is running and disconnected from all loads, apply a 12 VDC battery for one to two seconds as shown in the diagram. **Polarity must be correct: + to X, - to XX.**

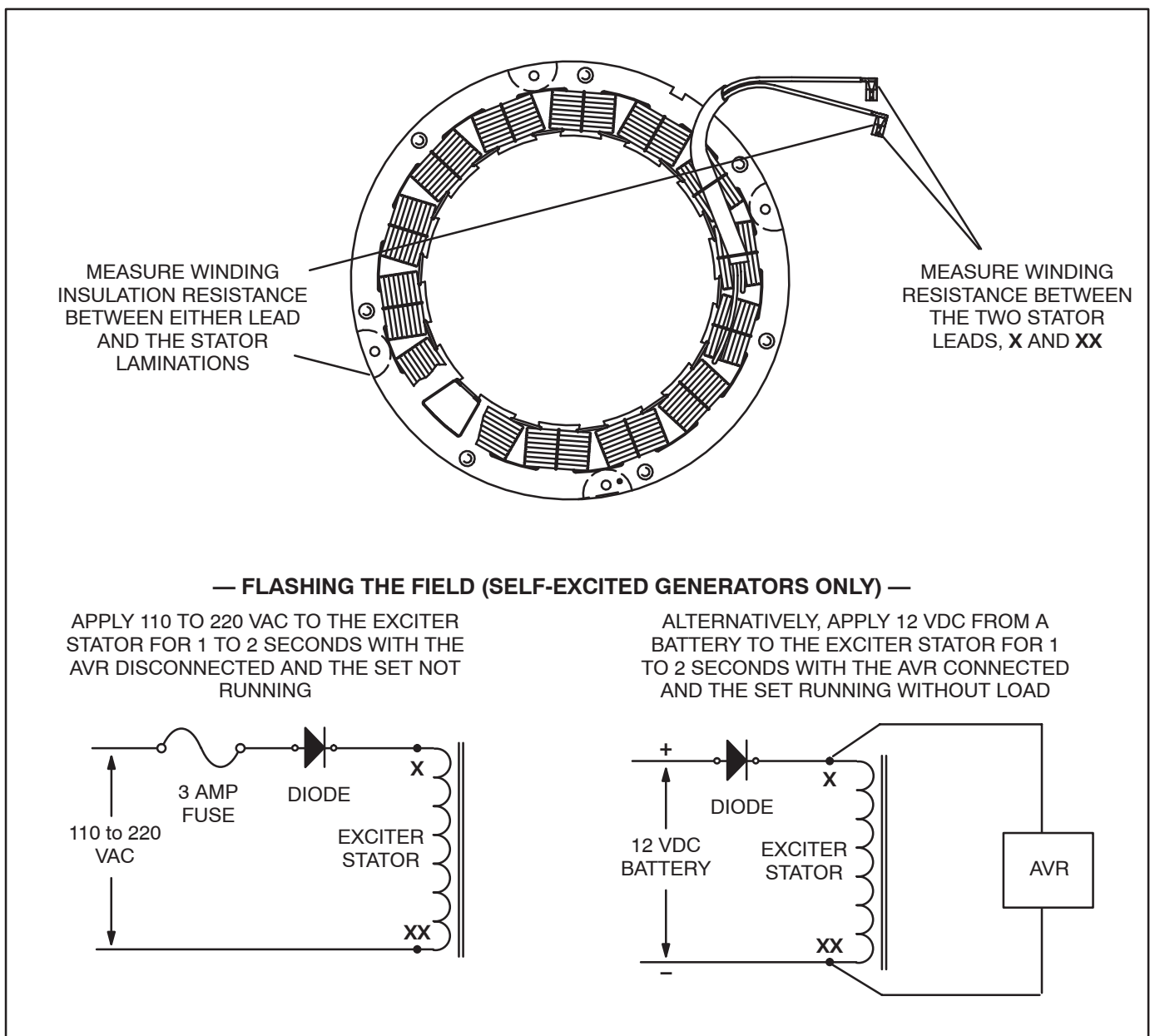

FIGURE 5-2. TESTING AND FLASHING THE EXCITER STATOR

Exciter Rectifier Bridge (Rotating Rectifier Assembly)

The exciter rectifier bridge is mounted on the exciter rotor, inboard, facing the main rotor. It consists of a positive plate and a negative plate, split diametrically. Each carries three diodes, three terminal posts for connecting exciter rotor leads to the diode pigtailed and a terminal for the main rotor (generator field) lead. A surge suppresser is connected across the two plates to prevent transient voltages that could damage the diodes.

Testing Diodes: Disconnect the diode pigtailed from the terminal posts. Using an ohmmeter, measure electrical resistance between each diode pigtail and the plate on which the diode is mounted. Reverse the meter test probes and repeat the tests. The electrical resistance across each diode should be high in one direction and low in the other. If the re-

sistance is high or low in both directions, replace the diode.

Replacing Diodes: Make sure the replacement diode is of the correct polarity. Disconnect the pigtail from the terminal post and unscrew the old diode. Apply heat-sink compound under the head of the diode. Make sure the compound does not get on the threads. Torque the diodes to 36 to 42 in-lbs (4 to 4.8 Nm) and the pigtail terminals to 24 in-lbs (2.7 Nm) when reassembling.

Surge Suppressor Testing and Replacement: Remove the suppresser. Replace the suppresser if it appears to have overheated or if ohmmeter readings indicate less than infinite resistance (end of scale) in both directions. Torque the terminals to 24 in-lbs (2.7 Nm) when reassembling.

CAUTION Layers of dust can cause diodes to overheat and fail. Brush dust off regularly.

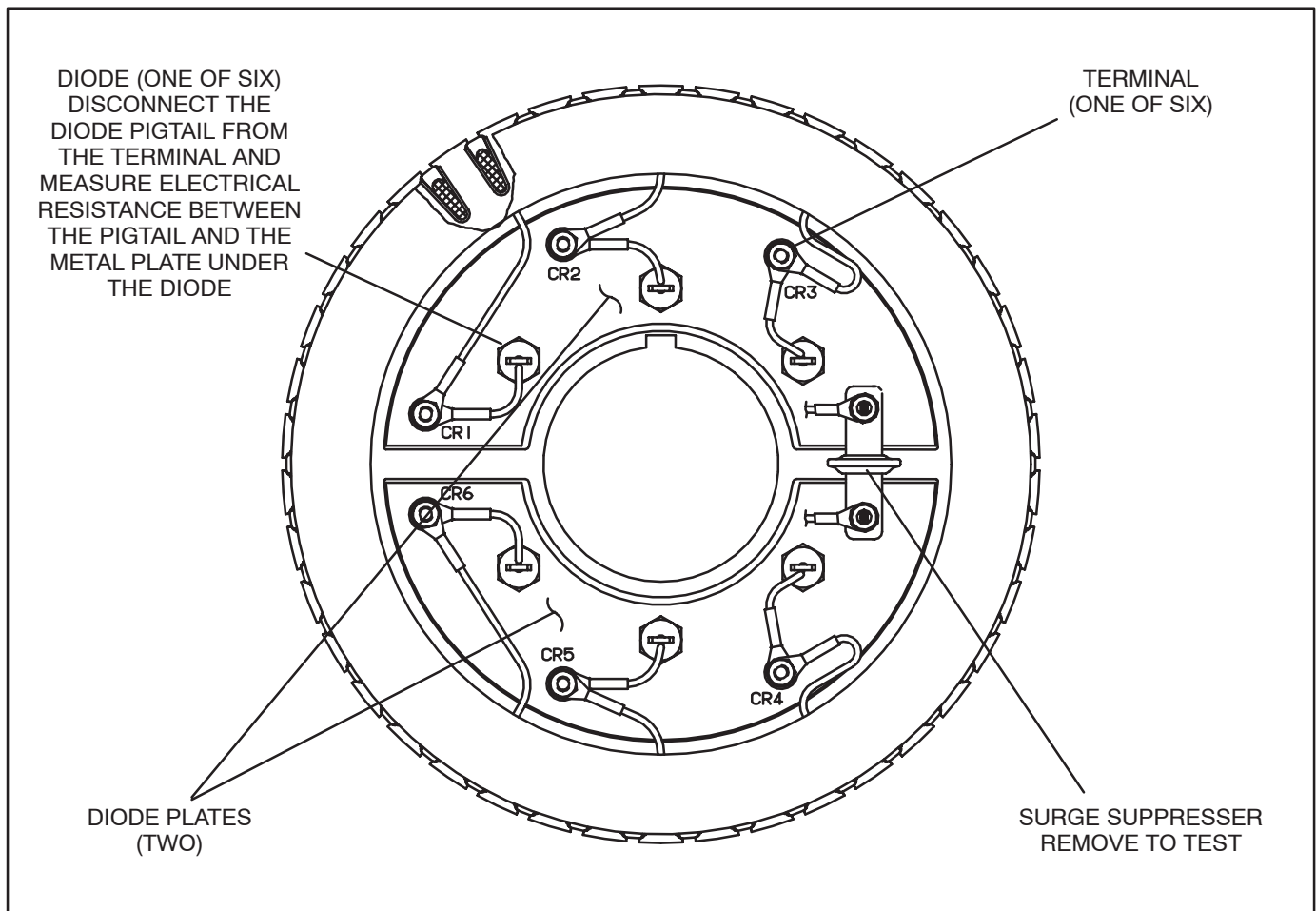

FIGURE 5-3. TESTING THE ROTATING RECTIFIER ASSEMBLY

Exciter Rotor

Testing Winding Resistance: Disconnect the six rotor winding leads from the terminal posts on the rectifier assembly. With a Wheatstone bridge, measure electrical resistance across each pair of rotor windings: **U** (CR1 or CR4) and **V** (CR2 or CR5), **V** (CR2 or CR5) and **W** (CR3 or CR6), **W** (CR3 or CR6) and **U** (CR1 or CR4). See the winding sche-

matic. Replace the whole rotor shaft assembly if the resistance of any winding is not as specified in Table 5-1.

Testing Winding Insulation Resistance: Using an ohmmeter, measure the resistance between any rotor winding lead or the terminal to which it is connected and the rotor laminations. Replace the whole rotor shaft assembly if insulation resistance is less than 1 megohm.

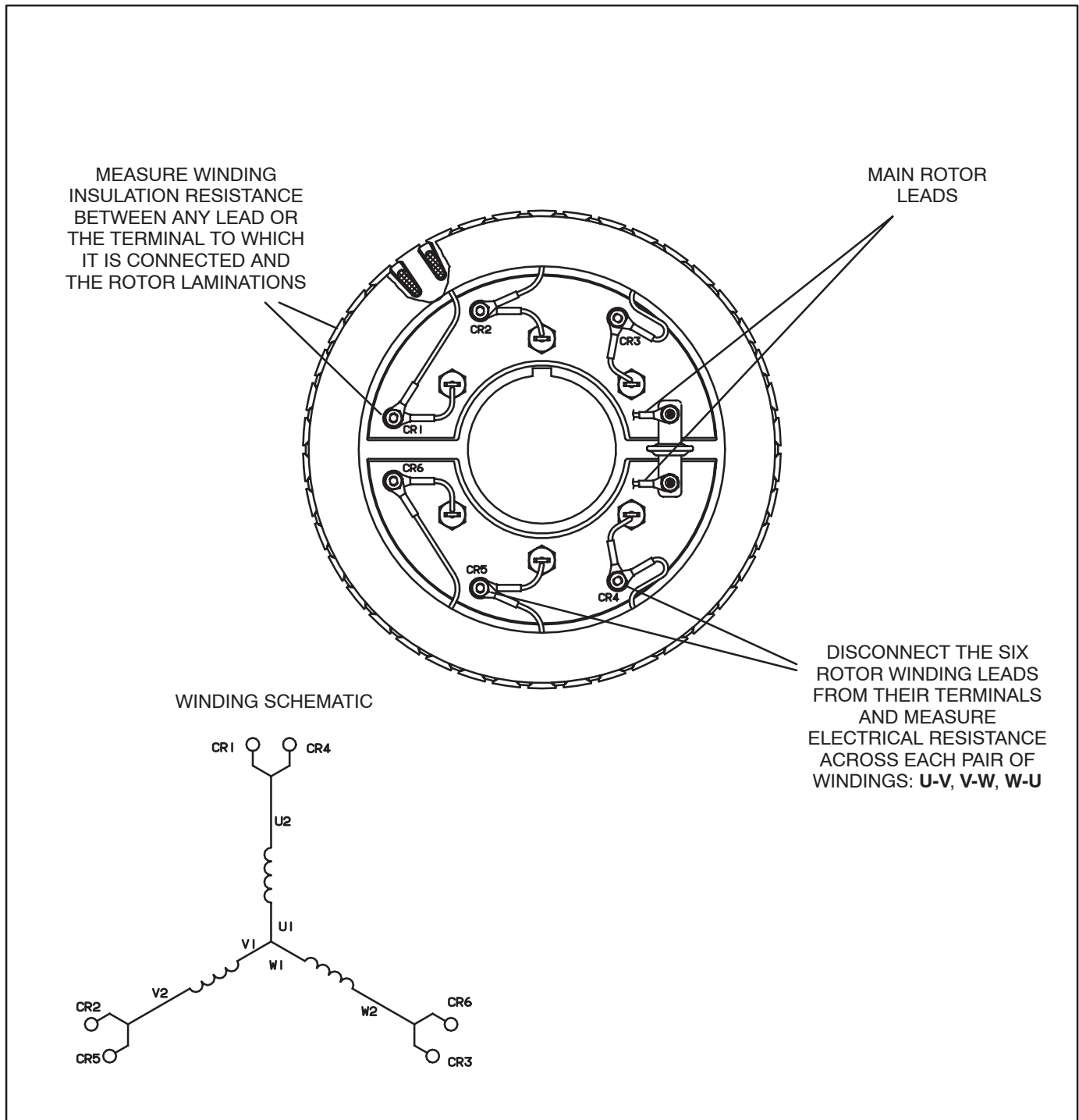

FIGURE 5-4. TESTING THE EXCITER ROTOR

Main Rotor (Generator Field)

Testing Winding Resistance: Disconnect the two leads of the main rotor from the terminals on the rotating rectifier assembly (Figure 5-4). Measure electrical resistance between the two leads with a Wheatstone bridge or digital ohmmeter. Replace the rotor if the resistance is not as specified in Table

5-1. Connect the rotor leads and torque the terminals to 24 in-lbs (2.7 Nm) when reassembling.

Testing Winding Insulation Resistance: Using an ohmmeter, measure the resistance between either lead of the main rotor windings, or the terminal to which it is connected, and the main rotor laminations. Replace the rotor if insulation resistance is less than 1 megohm.

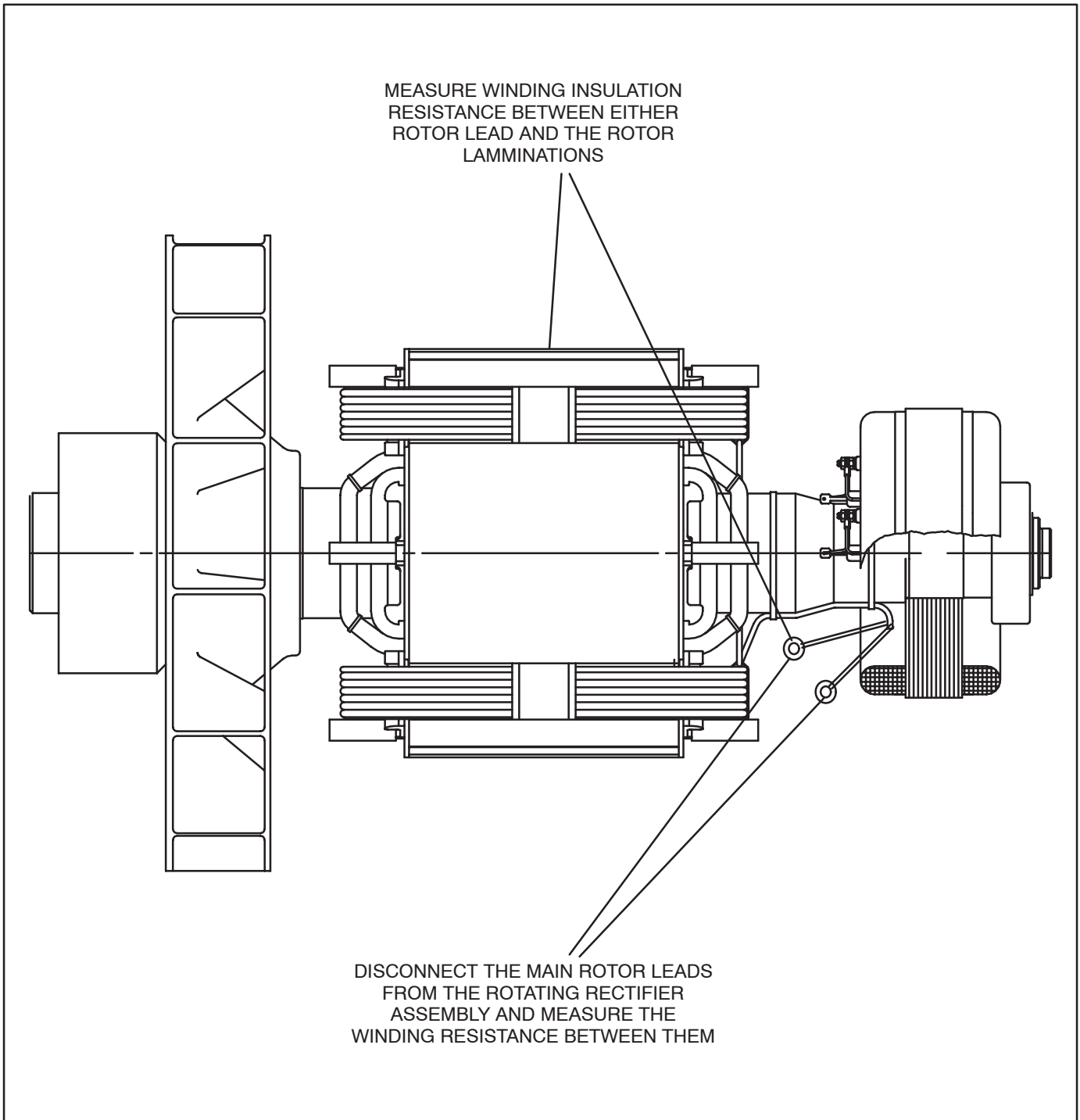

FIGURE 5-5. TESTING THE MAIN ROTOR

Main Stator

Testing Winding Resistance: Measure electrical resistance across each pair of stator leads (U1-U2, U5-U6, V1-V2, V5-V6, W1-W2 and W5-W6) with a Wheatstone bridge or ohmmeter having at least 0.001 ohm precision. Replace the stator if the resistance of any winding is not as specified in Table 5-1.

Alternatively, winding resistance can be measured line-to-line at the generator terminals (U-V, V-W, W-U) on “star” connected generators. On a 600 volt generator, line-to-line resistance should be twice the table value (two winding elements in series). On a “series star” connected generator, line-to-line re-

sistance should be four times the table value (four winding elements in series). On a “parallel star” connected generator, line-to-line resistance should be the same as the table value (two sets of two winding elements in series). Single phase only windings can be measured at W-V and should be twice the table value.

Testing Winding Insulation Resistance: Disconnect all stator leads and winding taps from their respective terminals and make sure the ends do not touch the generator frame. Using an ohmmeter, measure electrical resistance between any stator lead and the stator laminations. Replace the stator if insulation resistance is less than 1 megohm.

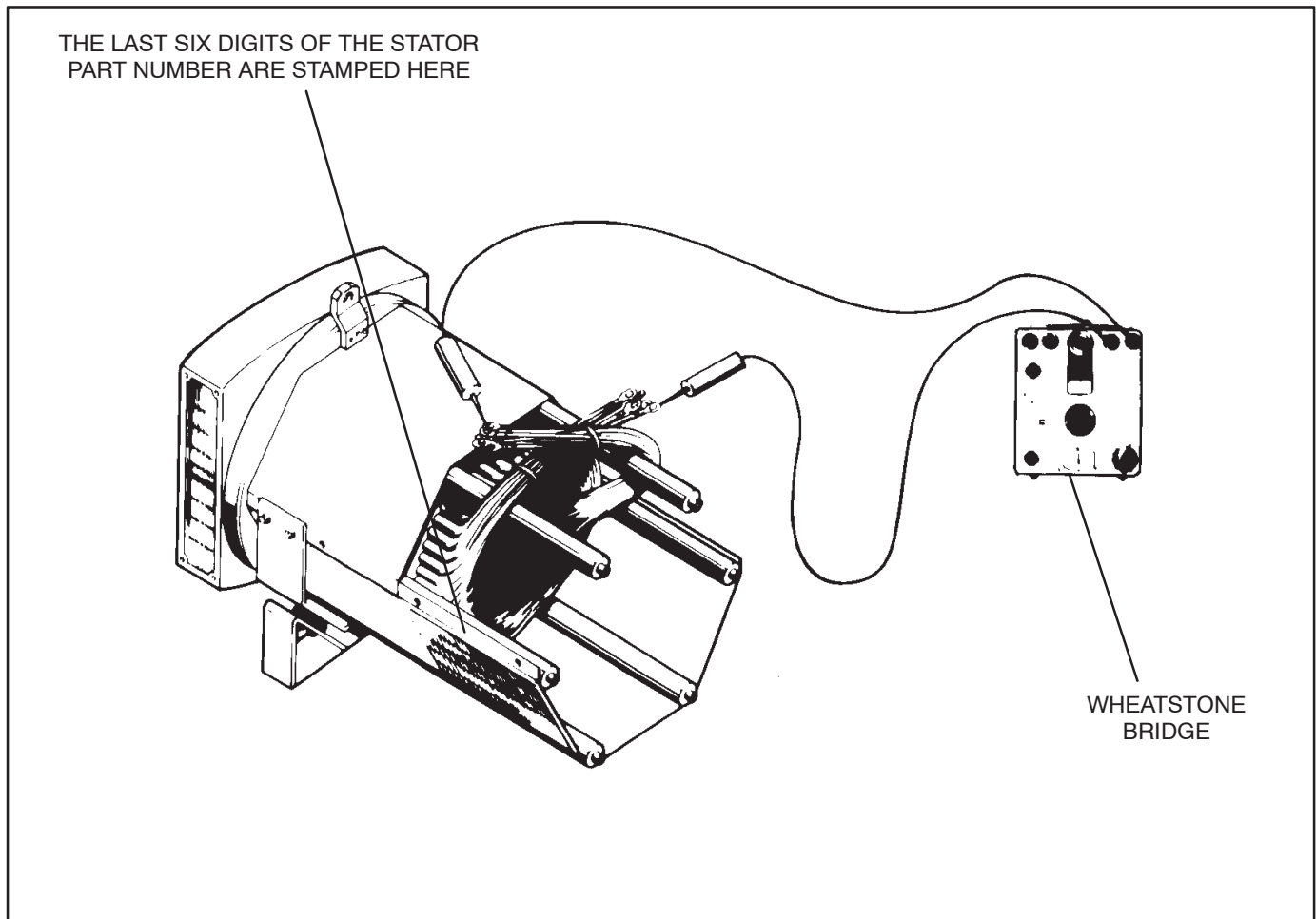

FIGURE 5-6. TESTING THE GENERATOR STATOR

TABLE 5-1. GENERATOR WINDING RESISTANCES

MAIN STATOR PART NUMBER***	MAIN STATOR (OHMS*)	MAIN ROTOR (OHMS**)	EXCITER STATOR (OHMS**)	EXCITER ROTOR (OHMS*)
220-4447-06	0.0561-0.0620	0.57	20.3	0.167
220-4447-07	0.0466-0.0515	0.64	20.3	0.167
220-4447-08	0.0371-0.0410	0.67	19.5	0.180
220-4447-09	0.0228-0.0252	0.80	19.5	0.180
220-4447-10	0.0181-0.0200	0.93	19.5	0.180
220-4447-11	0.0860-0.0950	0.57	20.3	0.167
220-4447-12	0.0613-0.0677	0.64	20.3	0.167
220-4447-13	0.0480-0.0530	0.67	19.5	0.180
220-4447-14	0.0309-0.0341	0.80	19.5	0.180
220-4447-15	0.0261-0.0289	0.93	19.5	0.180
220-4447-16	0.0561-0.0620	0.57	20.3	0.167
220-4447-17	0.0428-0.0473	0.64	20.3	0.167
220-4447-18	0.0333-0.0368	0.67	19.5	0.180
220-4447-19	0.0228-0.0252	0.80	19.5	0.180
220-4447-20	0.0171-0.0189	0.93	19.5	0.180
220-4447-26	0.1354-0.1496	0.57	20.3	0.167
220-4447-27	0.0960-0.1050	0.64	20.3	0.167
220-4447-28	0.0713-0.0788	0.67	19.5	0.180
220-4447-29	0.0485-0.0536	0.80	19.5	0.180
220-4447-30	0.0404-0.0446	0.93	19.5	0.180
220-4448-07	0.0209-0.0231	1.11	19.5	0.180
220-4448-08	0.0162-0.0179	1.20	19.5	0.180
220-4448-09	0.0143-0.0158	1.31	19.5	0.210
220-4448-10	0.0095-0.0105	1.50	19.5	0.210
220-4448-11	0.0076-0.0084	1.66	19.5	0.210
220-4448-12	0.0066-0.0072	1.80	19.5	0.210
220-4448-13	0.0260-0.0310	1.11	19.5	0.180
220-4448-14	0.0214-0.0236	1.20	19.5	0.180
220-4448-15	0.0147-0.0163	1.31	19.5	0.210
220-4448-16	0.0114-0.0126	1.50	19.5	0.210
220-4448-17	0.0100-0.0110	1.66	19.5	0.210
220-4448-18	0.0071-0.0079	1.80	19.5	0.210
220-4448-19	0.0204-0.0226	1.11	19.5	0.180
220-4448-20	0.0152-0.0168	1.20	19.5	0.180
220-4448-21	0.0105-0.0116	1.31	19.5	0.210
220-4448-22	0.0090-0.0100	1.50	19.5	0.210
220-4448-23	0.0076-0.0084	1.66	19.5	0.210
220-4448-24	0.0062-0.0068	1.80	19.5	0.210
(CONT.)				

* - These values are approximate, plus or minus 10 percent at 68° F (20° C).

** - These values are approximate, plus or minus 10 percent at 77° F (25° C).

*** - See Figure 5-6 for the location of the stator part number.

TABLE 5-1. GENERATOR WINDING RESISTANCES (CONT.)

MAIN STATOR PART NUMBER***	MAIN STATOR (OHMS*)	MAIN ROTOR (OHMS**)	EXCITER STATOR (OHMS**)	EXCITER ROTOR (OHMS*)
220-4448-31	0.0413-0.0457	1.11	19.5	0.180
220-4448-32	0.0229-0.0331	1.20	19.5	0.180
220-4448-33	0.0238-0.0263	1.31	19.5	0.210
220-4448-34	0.0181-0.0200	1.50	19.5	0.210
220-4448-35	0.0124-0.0137	1.66	19.5	0.210
220-4448-36	0.0133-0.0147	1.80	19.5	0.210
220-4448-37	0.0085-0.0095	2.05	19.5	0.210
220-4448-38	0.0095-0.0105	2.05	19.5	0.210
220-4448-39	0.0074-0.0082	2.05	19.5	0.210
220-4448-40	0.0066-0.0074	2.05	19.5	0.210
220-4448-41	0.0065-0.0073	2.05	19.5	0.210
220-4448-42	0.0131-0.0145	2.05	19.5	0.210

* - These values are approximate, plus or minus 10 percent at 68° F (20° C).

** - These values are approximate, plus or minus 10 percent at 77° F (25° C).

*** - See Figure 5-6 for the location of the stator part number.

REMOVING AND DISASSEMBLING THE GENERATOR

The generator is heavy. You will need an assistant and a hoist of sufficient capacity to remove and service the generator.

⚠ WARNING *Dropping the generator can damage it and cause severe personal injury and death. The hoist, straps and chains must have sufficient capacity and be attached properly so that the load cannot shift.*

Before starting, disconnect the negative (-) cable from the battery to make sure the set will not start while working on it.

⚠ WARNING *Ignition of explosive battery gases can cause severe personal injury. Arcing at battery terminals, light switch or other equipment, flame, pilot lights and sparks can ignite battery gas. Do not smoke, or switch trouble light ON or OFF near battery. Discharge static electricity from body before touching batteries by first touching a grounded metal surface.*

Ventilate battery area before working on or near battery—Wear goggles—Stop genset and disconnect charger before disconnecting battery cables—Disconnect negative (-) cable first and reconnect last.

⚠ CAUTION *Disconnect battery charger from AC source before disconnecting battery cables. Otherwise, disconnecting cables can result in voltage spikes damaging to DC control circuits of the set.*

⚠ WARNING *Accidental starting of the generator set can cause severe personal injury or death. Prevent accidental starting by disconnecting the negative (-) cable from the battery terminal.*

Removing The Generator Output Box

1. Disconnect the line cables and conduit. For reconnections later, make sure each cable is clearly marked to indicate the correct terminal.
2. Disconnect the remote control wiring and conduit. For reconnections later, make sure each wire is clearly marked to indicate the correct terminal.
3. Disconnect all engine wiring harness connections in the generator control and output boxes.

For reconnections later, make sure each wire is clearly marked to indicate the correct terminal.

4. Disconnect all generator control leads (winding taps) from connections in the output box. For reconnections later, make sure each wire is clearly marked to indicate the correct terminal.
5. If the set has a mounted line circuit breaker, disconnect the cables to the circuit breaker. For reconnections later, make sure each cable is clearly marked to indicate the correct terminal.
6. Attach a hoist to the generator output box, loosen the mounting bolts on the sides of the generator and remove the box.

Withdrawing The Generator From The Set

⚠ CAUTION *Do not use fan blade to bar over engine. That can damage blades and cause property damage and personal injury.*

1. The rotor will be carried inside the stator when the generator is withdrawn from the engine. Bar the engine until one of the four poles of the rotor points straight down so that the rotor will rest on the face of the pole when the generator is withdrawn.

⚠ CAUTION *The rotor can be damaged if it rests on the edges of the winding slot between two poles.*

2. Attach lifting eyes and a hoist of sufficient capacity (Figure 5-7).
3. Take up hoist slack and remove the bolts securing the generator rubber isolation mounts to the skid.
4. Raise the generator end approximately one inch (12 mm) and securely block the engine under the flywheel housing. Lower the generator slightly so that the blocks carry most of the weight.
5. Remove the bolts securing the generator drive discs to the flywheel.
6. Loosen all the bolts securing the generator adapter casting to the flywheel housing. Adjust the hoist to carry the full weight of the generator, remove the bolts and pull the generator away.

⚠ CAUTION *Never withdraw the generator leaving the rotor to hang by the drive discs. The weight of the rotor will damage the drive discs.*

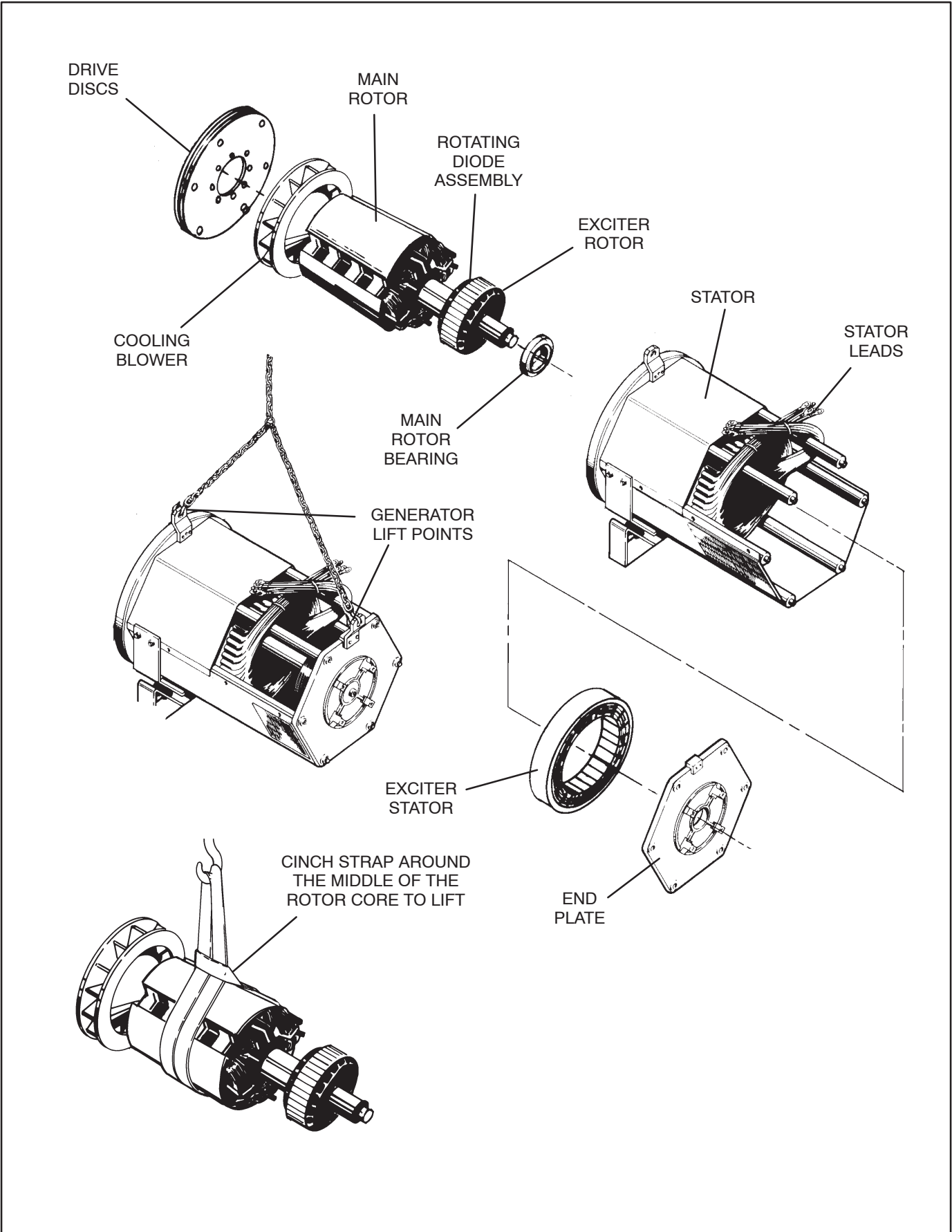

FIGURE 5-7. GENERATOR ASSEMBLY

Withdrawing the Rotor From the Generator

1. Remove the generator adaptor casting on the drive disc end and the end plate on the bearing end.
2. Using a hoist of sufficient capacity, cinch a lifting strap on the drive end of the rotor. Lift the bearing end of the rotor by hand and push it towards the drive end of the generator until half the width of the rotor core protrudes from the stator. Release the weight of the rotor and re-cinch the lifting strap around the middle of the rotor core. Withdraw the rotor until it is free of the stator, guiding it by hand on both ends to prevent contact with the stator windings
3. Rest the rotor in a cradle, solidly supporting it on two pole faces—not on the drive discs, blower or exciter.
4. Remove the retaining clip if the rotor shaft bearing is to be removed.

REASSEMBLING THE GENERATOR

Reassembling is the reverse of disassembling. Note the following.

1. Apply force to the inner race of the rotor bearing when pressing it onto the shaft, otherwise, it will be damaged. Be sure to secure the retaining clip.
2. The drive disc-to-rotor bolts should be torqued to 117-118 ft-lbs (145-160 Nm).
3. The drive disc-to-flywheel bolts should be torqued to 40-50 ft-lbs (54-68 Nm).
4. The exciter stator mounting screws should be torqued to 7.4-8.9 ft-lbs (10-12 Nm).
5. The generator end plate mounting bolts should be torqued to 19-23 ft-lbs (26-31 Nm).
6. Make sure the rubber O-ring is in place in the bearing bore in the generator endplate.
7. The generator mounting bracket bolts should be torqued to 37-44 ft-lbs (50-59 Nm) if M10.
8. The generator-to-adaptor bolts should be torqued to 18-22 ft-lbs (24-30 Nm).
9. The adaptor-to-engine bolts should be torqued to 30-40 ft-lbs (40-54 Nm).
10. Reconnect the generator as required. See Page 10-3 or 10-4.

SERVICING THE PMG

The following is applicable if the generator is equipped with a PMG (permanent magnet) exciter.

Testing

1. Disconnect leads **P2**, **P3** and **P4** from the voltage regulator.
2. Start the engine at the set and let the speed stabilize.

⚠ WARNING **HAZARDOUS VOLTAGE.** *Touching uninsulated parts inside the control housing and power output boxes can result in severe personal injury or death. Measurements and adjustments must be done with care to avoid touching hazardous voltage parts.*

Stand on a dry wooden platform or rubber insulating mat, make sure your clothing and shoes are dry, remove jewelry and use tools with insulated handles.

3. Measure voltage across lead pairs **P2-P3**, **P3-P4** and **P4-P2**. Voltage should be at least 150 VAC for 50 Hz sets and at least 180 VAC for 60 Hz sets, and should be approximately the same for each set of leads. If the voltages are low or uneven, check all the leads and connections between the voltage regulator and the PMG and repair as necessary before disassembling the PMG. Note the connections at the auxiliary terminal board in the power output box. See Figure 2-3.
4. Stop the set and measure electrical resistance across lead pairs **P2-P3**, **P3-P4** and **P4-P2** with a Wheatstone bridge or digital ohmmeter. Each winding should have a resistance of approximately 4.4 ohms.

Disassembling the PMG

1. Disconnect the negative (-) cable from the battery to prevent accidental starting.

⚠ WARNING Ignition of explosive battery gases can cause severe personal injury. Arcing at battery terminals, light switch or other equipment, flame, pilot lights and sparks can ignite battery gas. Do not smoke, or switch trouble light ON or OFF near battery. Discharge static electricity from body before touching batteries by first touching a grounded metal surface.

Ventilate battery area before working on or near battery—Wear goggles—Stop genset and disconnect charger before disconnecting battery cables—Disconnect negative (-) cable first and reconnect last.

⚠ CAUTION Disconnect battery charger from AC source before disconnecting battery cables. Otherwise, disconnecting cables can result in voltage spikes damaging to DC control circuits of the set.

⚠ WARNING Accidental starting of the generator set can cause severe personal injury or death. Prevent accidental starting by disconnecting the negative (-) cable from the battery terminal.

2. Remove the PMG cover and disconnect the leads at the connector.
3. Remove the bolts and clamps that secure the PMG stator to the generator frame and carefully pull away the stator.

The rotor is magnetic and will attract the stator. Hold the stator firmly so that the windings are not damaged by striking the stator support lugs.

4. Remove the rotor center bolt and pull away the rotor. The rotor is magnetic and will attract iron filings. Put it in a clean plastic bag until it is re-mounted. Do not take it apart or it will lose its magnetism. Also, if the dowel pin in the end of the shaft is loose, stow it in a safe place until it is time to reassemble the PMG.

Reassembling the PMG

Reassembling is the reverse of disassembling. Torque the rotor center bolt to 40 ft-lbs (54 Nm). The stator leads must be at 12 o'clock.

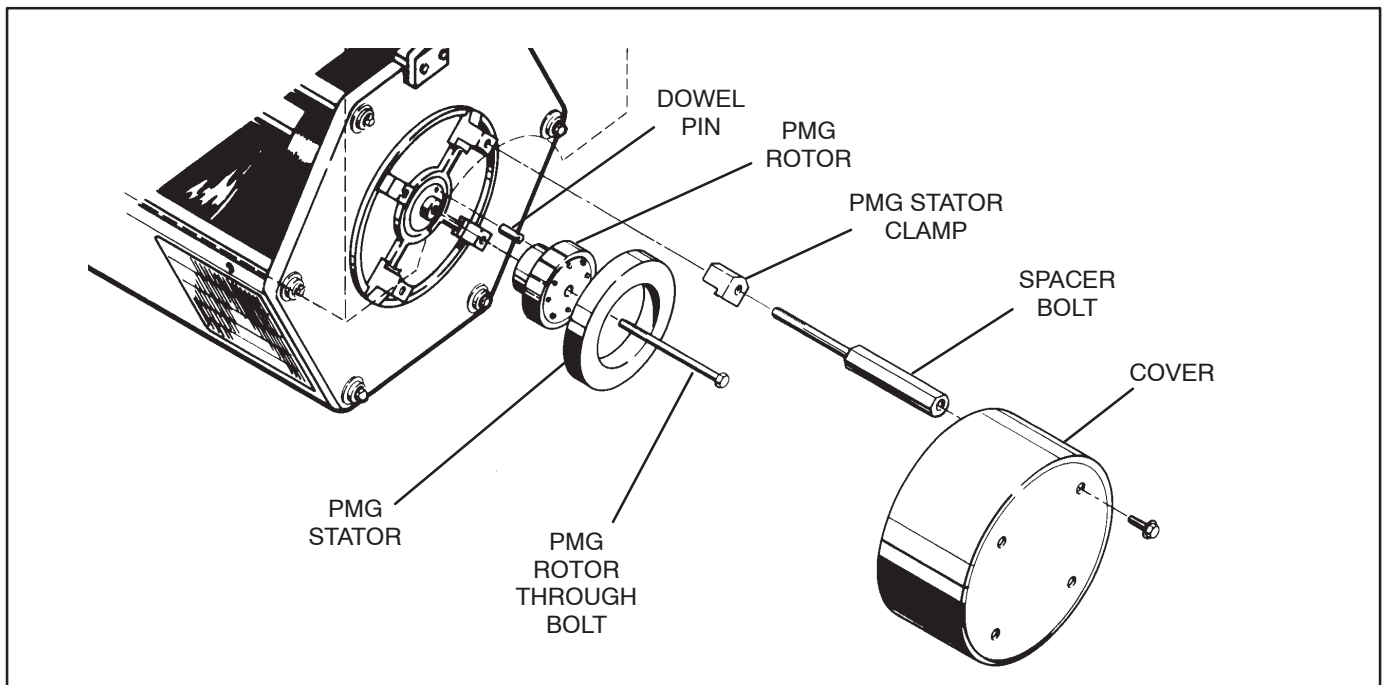

FIGURE 5-8. PMG ASSEMBLY

6. Governors and Fuel Systems

GENERAL

There are two types of governor systems used on the GG Series gensets. **Type A** consist of a governor controller board, governor actuator and linkage (Figures 6-3 and 6-4).

Type B is an integrated governor system (Figure 6-8). That is, the governor controller, actuator and linkage are contained within a governor assembly which is attached to the side of the mixer.

This section provides the fuel system and governor adjustment procedures for **Type A** and **Type B** systems.

FUEL PRESSURE (TYPE A & B)

Gaseous and Combination Fuel Systems

An engine equipped for natural gas and LPG has a gas mixer that serves both fuels. Each fuel has a separate shutoff solenoid valve and pressure fuel pressure switch for automatic fuel changeover.

While the engine is running, the gas pressure switch causes the natural gas solenoid valve to

close and the LPG solenoid valve to open when natural gas pressure is lost, without stopping the engine. When natural gas pressure is restored, the natural gas solenoid valve opens and the LPG solenoid valve closes.)

Fuel Pressure

The fuel regulators in each line provide constant gas pressure at the gas mixer under varying load conditions. There are pressure test ports on both sides of the fuel regulator for measuring supply and regulated fuel pressures (NG or LPG systems).

Mixer side: The NG gas pressure should be approximately 5 inches WC at full load.

The LPG gas pressure will be approximately negative 0.5 inches WC at no load and a negative pressure of 1.0 inch WC at full load.

Supply side: The minimum pressure refers to supply pressure under rated load (maximum gas flow).

For LPG and natural gas, the maximum permissible fuel supply pressure is 13.6 inches WC (3.4 kPa) and the minimum is 7 inches WC (1.7 kPa).

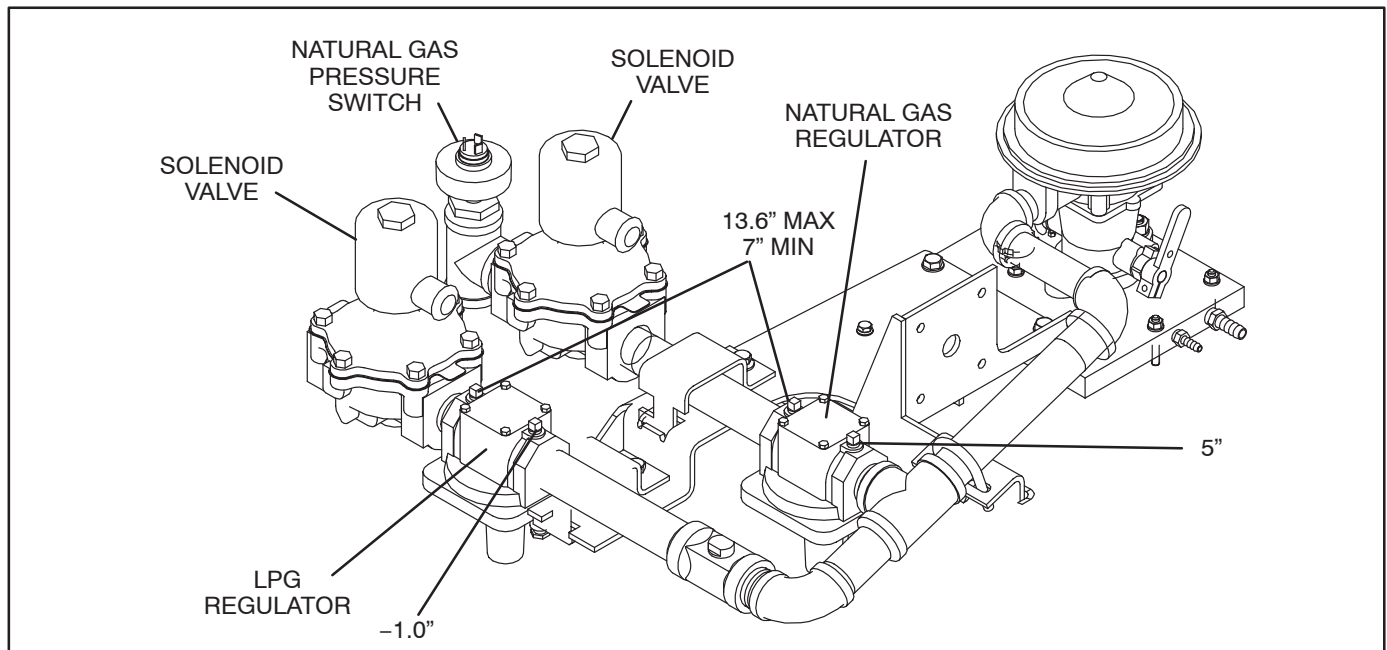

FIGURE 6-1. TYPICAL FUEL PRESSURE TEST LOCATIONS

TYPE A GOVERNOR/FUEL SYSTEM ADJUSTMENTS

If necessary, adjust the gas mixture, the governor linkage and the magnetic speed pickup unit as instructed in this section before adjusting the governor controller. Make sure that the governor assembly is securely mounted. Also make sure that the governor linkage does not bind or have excessive play in it.

Electric Governor Adjustment

1. Make sure that the timing wires are properly connected for the genset fuel type as follows. (Harness connectors P10, P11 and K1- are located just below the governor controller board.)

Natural Gas: P11 to P10 (B+)
 Propane: P11 to K1- (Gnd)
 Dual Fuel: Automatically switched.

2. Check the dip switch settings (Figure 6-1) to make sure they are properly set, as follows:

	50 Hz	60 Hz
SW1	Open	Open
SW2	Closed	Closed
SW3	Open	Closed
SW4	Closed	Closed

3. Start the set, let the engine warm up under a partial load (at least 1/4 rated load) and then disconnect all loads. (If the governor has been replaced, adjust the Gain to 7.5 and Stability to 2.5.)
4. Adjust Gain 1 pot until engine is stable and responsive to governor control. (Adjust the Gain pot counterclockwise to eliminate hunting.) Bump throttle lever a couple of times to check for hunting. The unit should respond quickly but should not hunt.
5. Apply full load to the genset and adjust Stability pot to minimize overshoot. (Adjust the Stability pot clockwise to increase stability.) Check stability under a range of loads; from no-load to full-load.
6. Attach a tachometer or frequency meter to the generator output leads if control panel does not come equipped with one of these meters. Adjust Speed Trim pot until desired speed is obtained.
7. Shut down and restart the genset to check for overspeed shutdown on startup.

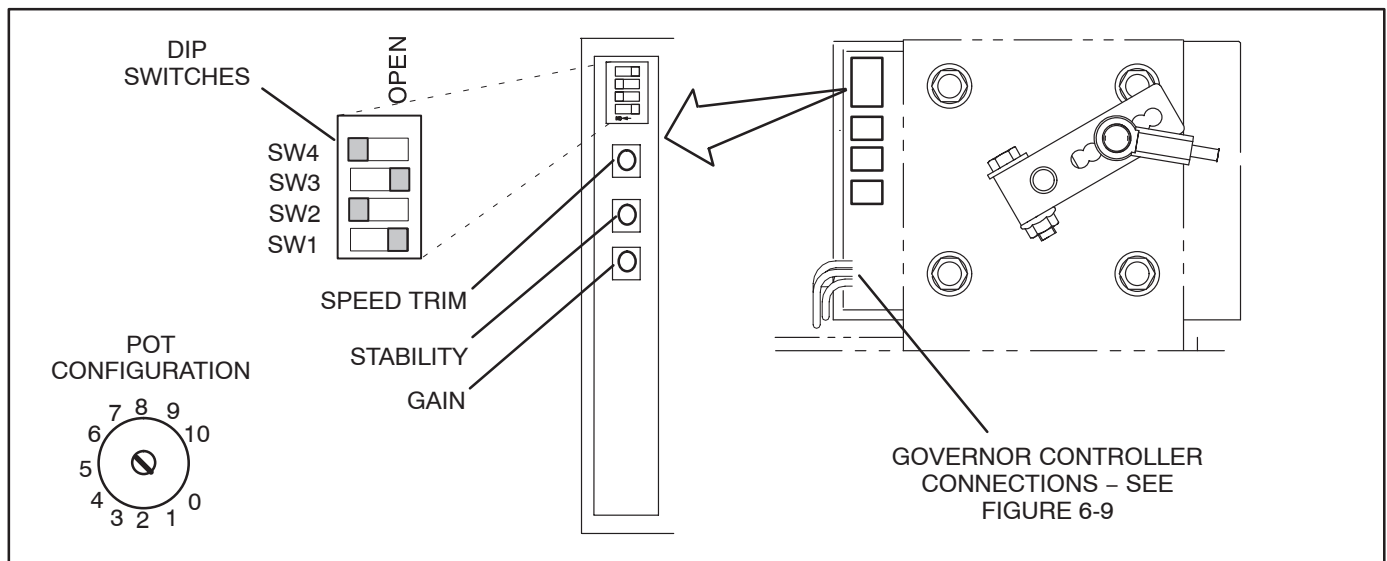

FIGURE 6-2. GOVERNOR CONTROLLER

Linkage Adjustment (Ten Cylinder)

Figure 6-3 illustrates the governor linkage for the ten cylinder engine. Make sure that the governor controller is securely mounted to the engine bracket. To adjust linkage:

1. With the genset stopped, remove the governor rod from the throttle lever. With the governor actuator shaft rotated to the full clockwise position, check that the angle of the governor arm is 30 ± 5 degrees. Loosen governor arm screw to adjust the governor arm.
2. Verify that the ball joint screw is mounted in fourth hole from the outside end of the governor arm.
3. Set length of rod approximately two turns longer than center to center distance between rod end holes in levers. Rod length shown in Figure 6-2 is approximate.
4. Attach governor rod to the throttle lever.

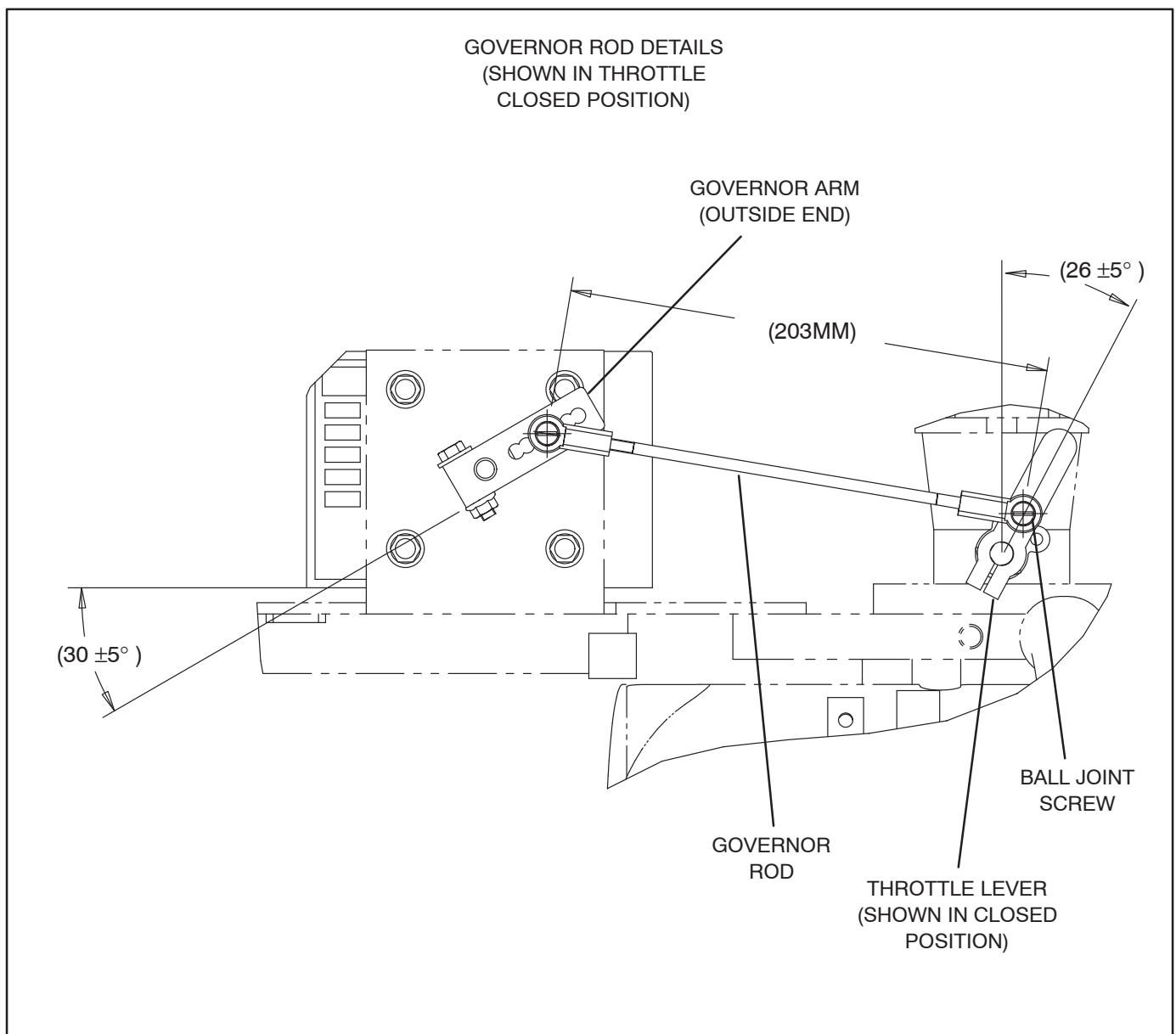

FIGURE 6-3. V10 ENGINE GOVERNOR LINKAGE

Linkage Adjustment (Six Cylinder Engine)

Figure 6-4 illustrates the governor linkage for the six cylinder engine. Make sure that the governor controller is securely mounted to the engine bracket. To adjust linkage:

1. With the genset stopped, remove the governor rod from the throttle lever. With the governor actuator shaft rotated to the full clockwise position, check that the angle of the governor arm is

20 ± 5 degrees. Loosen governor arm screw to adjust the governor arm.

2. Verify that the ball joint screw is mounted in third hole from the outside end of the governor arm.
3. Set length of rod approximately two turns longer than center to center distance between rod end holes in levers. Rod length shown in Figure 6-2 is approximate.
4. Attach governor rod to the throttle lever.

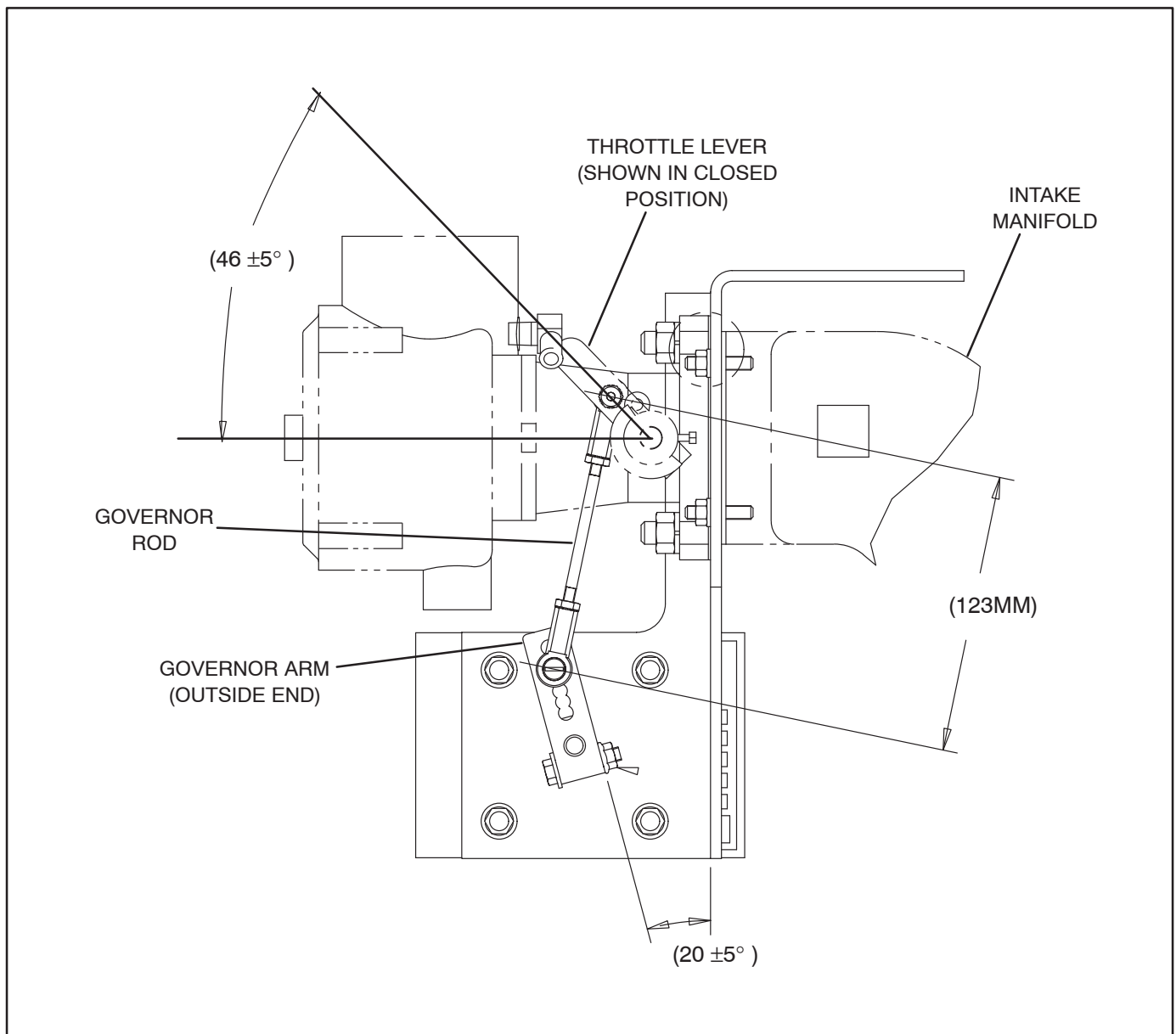

FIGURE 6-4. V6 ENGINE GOVERNOR LINKAGE

Fuel System (Type A)

The engine is equipped with a gas mixer to run on natural gas or LPG or both (Figure 6-5).

If converting a naturally aspirated fuel system to a different fuel or to a dual fuel system, the fuel system and the ignition timing may need to be adjusted. (Refer to Electric Governor Adjustment – Step 1, for timing adjustment.)

⚠WARNING *Gaseous fuels are flammable and explosive and can cause severe personal injury or death. Do not allow cigarettes, flame, pilot lights, arcing switches or equipment in area or areas sharing ventilation. Keep a type ABC fire extinguisher handy.*

Natural gas is lighter than air, and will tend to gather under hoods. LPG is heavier than air, and will tend to gather in sumps or low areas. NFPA Standard No. 58 requires all persons handling and operating LPG to be trained in proper handling and operating procedures.

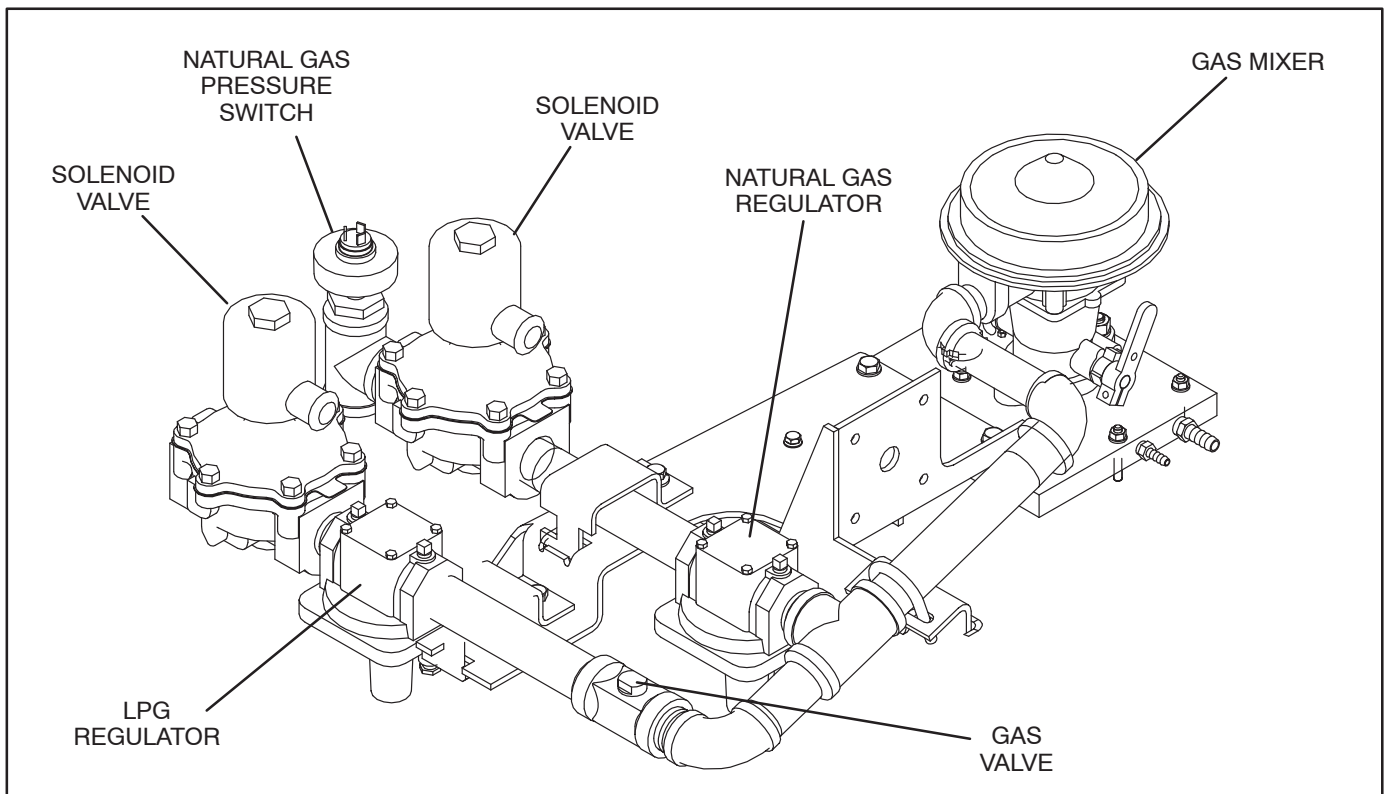

FIGURE 6-5. NATURAL GAS AND LPG VAPOR FUEL SYSTEM

Gaseous Fuel Adjustments: Gas mixers have a main fuel valve and an idle adjustment screw (Figures 6-6). Engines equipped for natural gas and LPG (dual fuel) also have a LPG flow adjustment valve. If necessary, make the following adjustments.

For applications in emission sensitive areas, final adjustment of the fuel/air ratio should be set using an exhaust gas analyzer.

1. Start the engine and let the set warm up under a partial load (at least 1/4 rated load). If the engine is equipped for natural gas and LPG, start with natural gas.

Step 2 is only required if genset instability is present at no-load through 1/4 of rated load.

2. *Naturally aspirated genset only:* Disconnect all loads, shut down the set and disconnect the governor linkage at the carburetor. Start the engine and close and hold the throttle by hand so

that the engine does not overspeed. While holding the throttle closed, adjust the throttle idle position screw (the one next to the throttle lever) to obtain a frequency of 25–35 Hz. Then turn the idle adjusting screw counterclockwise until engine speed becomes unstable. Turn the screw clockwise just enough to regain stability and reconnect the governor linkage.

3. Next, connect full rated load and turn the main fuel valve to full-rich. Slowly turn the fuel valve towards lean until the engine begins to lose speed and then slowly back towards rich until the engine carries the full load smoothly.
4. If the set is equipped for natural gas and LPG, switch to LPG by closing the manual shutoff valve in the natural gas supply line.
5. With full rated load, turn the LPG flow adjustment valve clockwise until the engine begins to lose speed and then slowly turn it back counterclockwise until the engine carries full load smoothly.

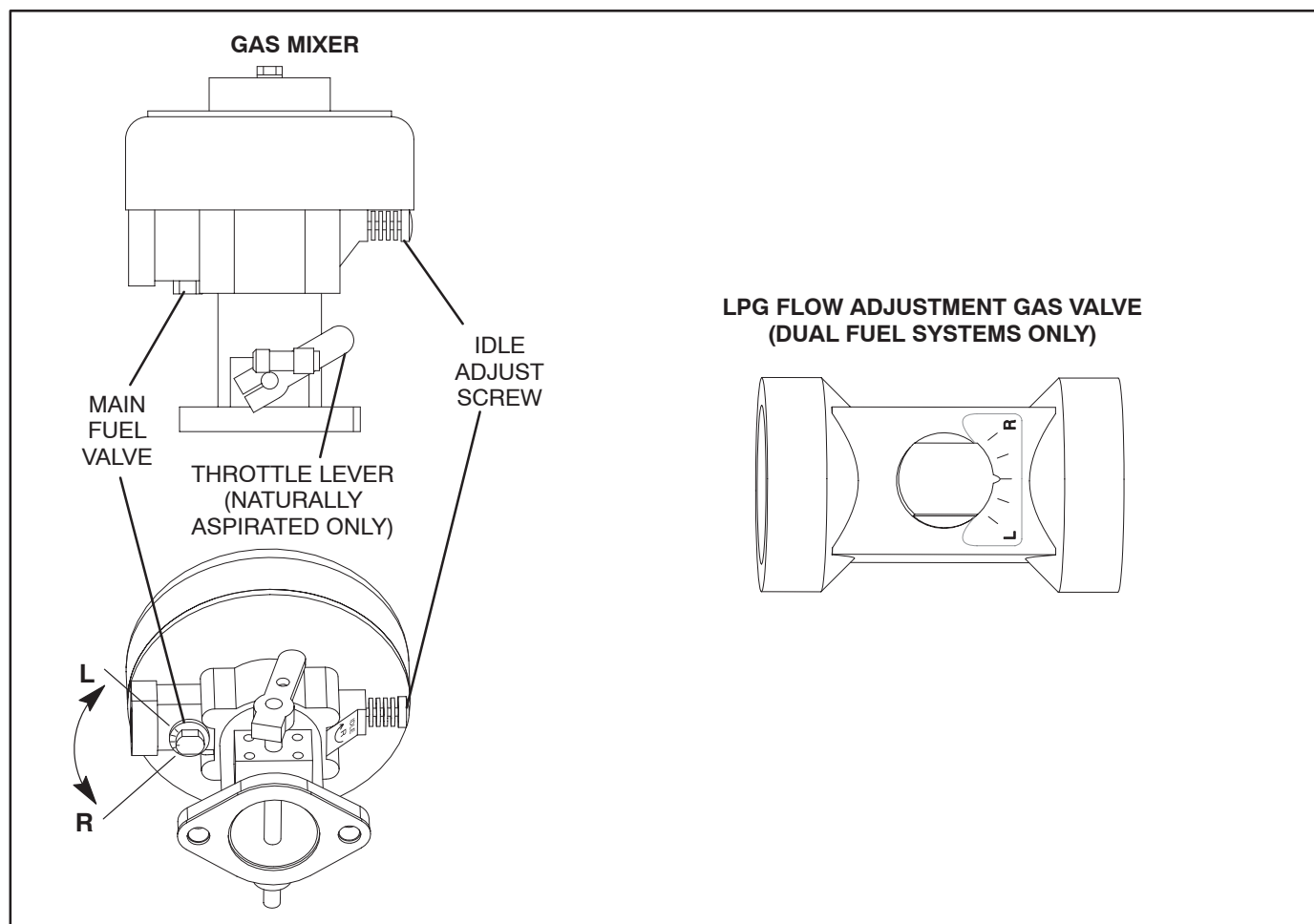

FIGURE 6-6. GASEOUS FUEL ADJUSTMENTS

TYPE B GOVERNOR/FUEL SYSTEM ADJUSTMENTS

The governor assembly is a preprogrammed digital integrated governor and requires no adjustment.

Integrated Governor (Type B)

To verify if the governor is operating, remove the small shaft cover (see Figure 6-6). The shaft should rotate about 20 degrees when cranking. If no rotation is seen, check wiring before replacing the governor (see Section 7).

Fuel System (Type B)

The engine is equipped with a gas mixer to run on natural gas or LPG or both (Figure 6-7).

⚠WARNING Gaseous fuels are flammable and explosive and can cause severe personal injury or death. Do not allow cigarettes, flame, pilot lights, arcing switches or equipment in area or areas sharing ventilation. Keep a type ABC fire extinguisher handy.

Natural gas is lighter than air, and will tend to gather under hoods. LPG is heavier than air, and will tend to gather in sumps or low areas. NFPA Standard No. 58 requires all persons handling and operating LPG to be trained in proper handling and operating procedures.

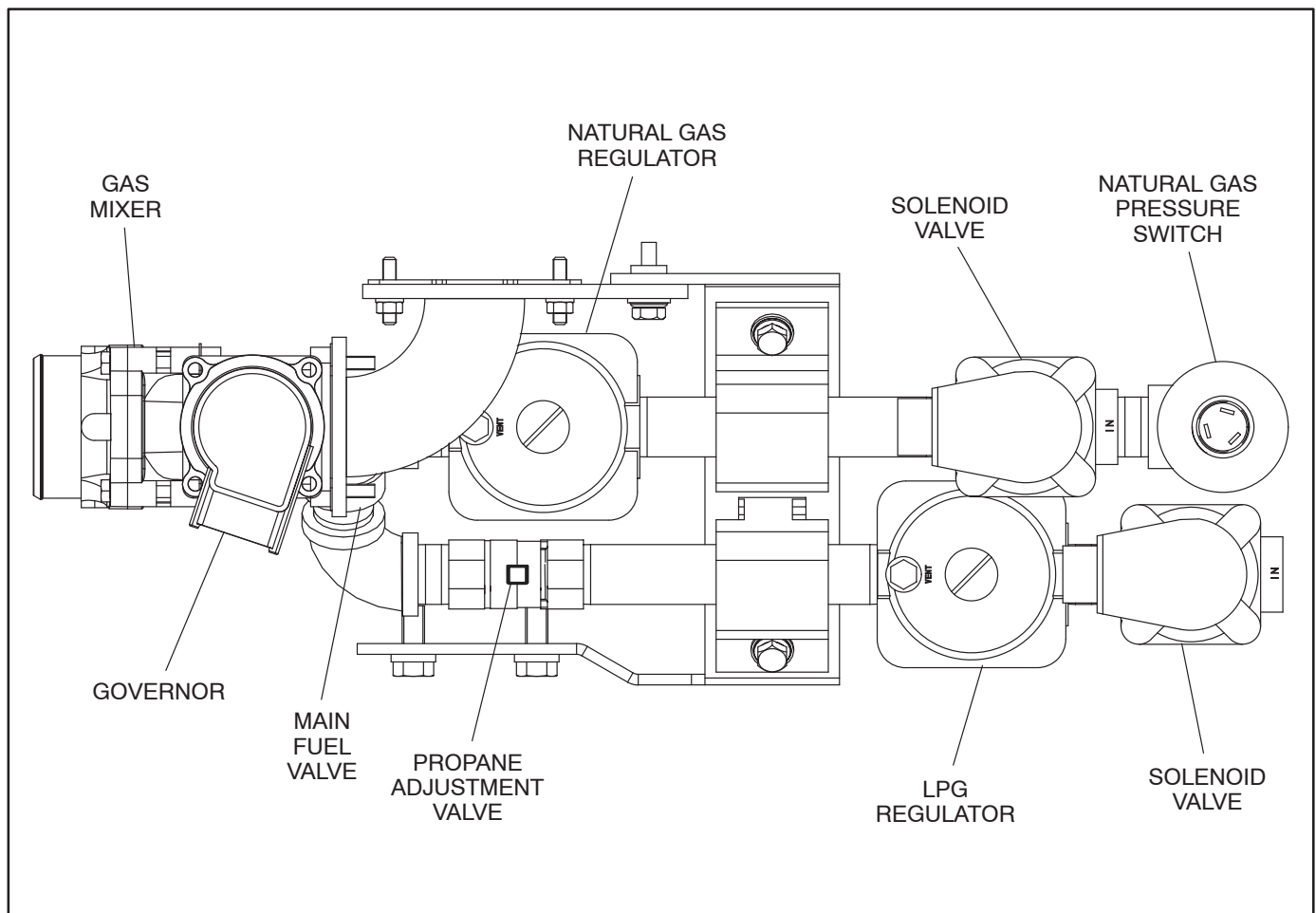

FIGURE 6-7. NATURAL GAS AND LPG VAPOR FUEL SYSTEM

Gaseous Fuel Adjustments: The fuel system contains either a manual main fuel valve, which may require adjustment or an automatic main fuel valve (no adjustment required) as shown in Figure 6-8.

Engines equipped for natural gas and propane (dual fuel) also have a propane flow adjustment valve. If necessary, make the following adjustments.

For applications in emission sensitive areas, final adjustment of the fuel/air ratio should be set using an exhaust gas analyzer.

1. Start the engine and let the set warm up under a partial load (at least 1/4 rated load). If the en-

gine is equipped for natural gas and propane, start with natural gas.

2. Connect full rated load and turn the manual main fuel valve two turns counterclockwise. Slowly turn the main fuel valve clockwise (lean) until the engine begins to lose speed and then slowly counterclockwise (rich) until the engine carries the full load smoothly.
3. If the set is equipped for natural gas and LPG, switch to LPG by closing the manual shutoff valve in the natural gas supply line.
4. Reconnect full rated load and turn the LPG flow adjustment valve clockwise until the engine begins to lose speed and then slowly turn it back counterclockwise until the engine carries full load smoothly.

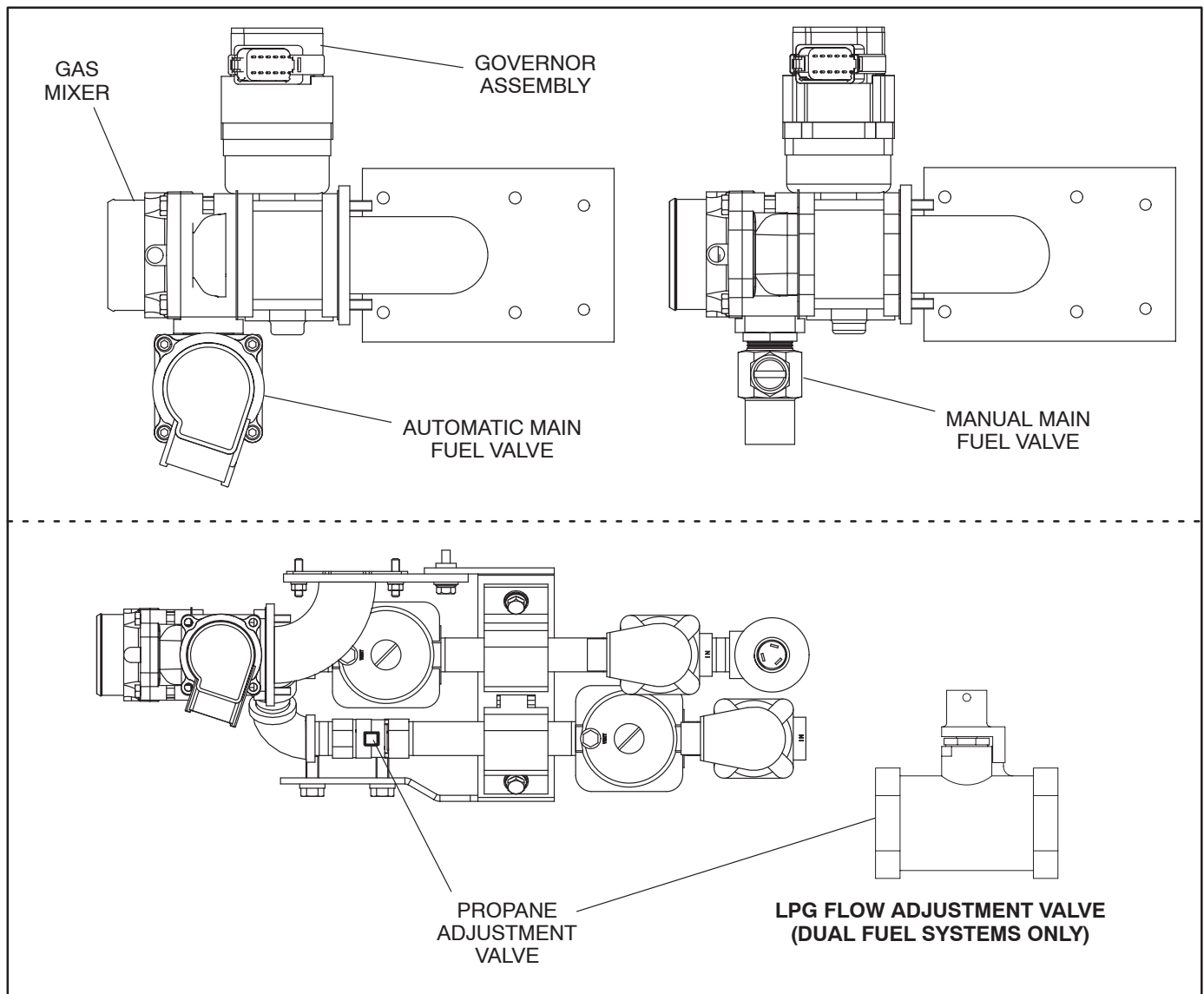

FIGURE 6-8. GASEOUS FUEL ADJUSTMENTS

MAGNETIC SPEED PICKUP UNIT ADJUSTMENT

Measure the resistance of the magnetic speed pickup (MPU). Replace the MPU if the resistance is not between 1,000 ohms and 1,050 ohms.

With the MPU removed from the genset, manually

rotate the ring gear until a tooth lines up in the center of the mounting hole. Thread the pickup in gently by hand until it just touches the ring gear tooth. Back it out 1/4 turn and set the locknut.

After adjustment, make sure output voltage of the MPU is correct. Replace the MPU if output voltage at cranking speed is less than 1.5 VAC.

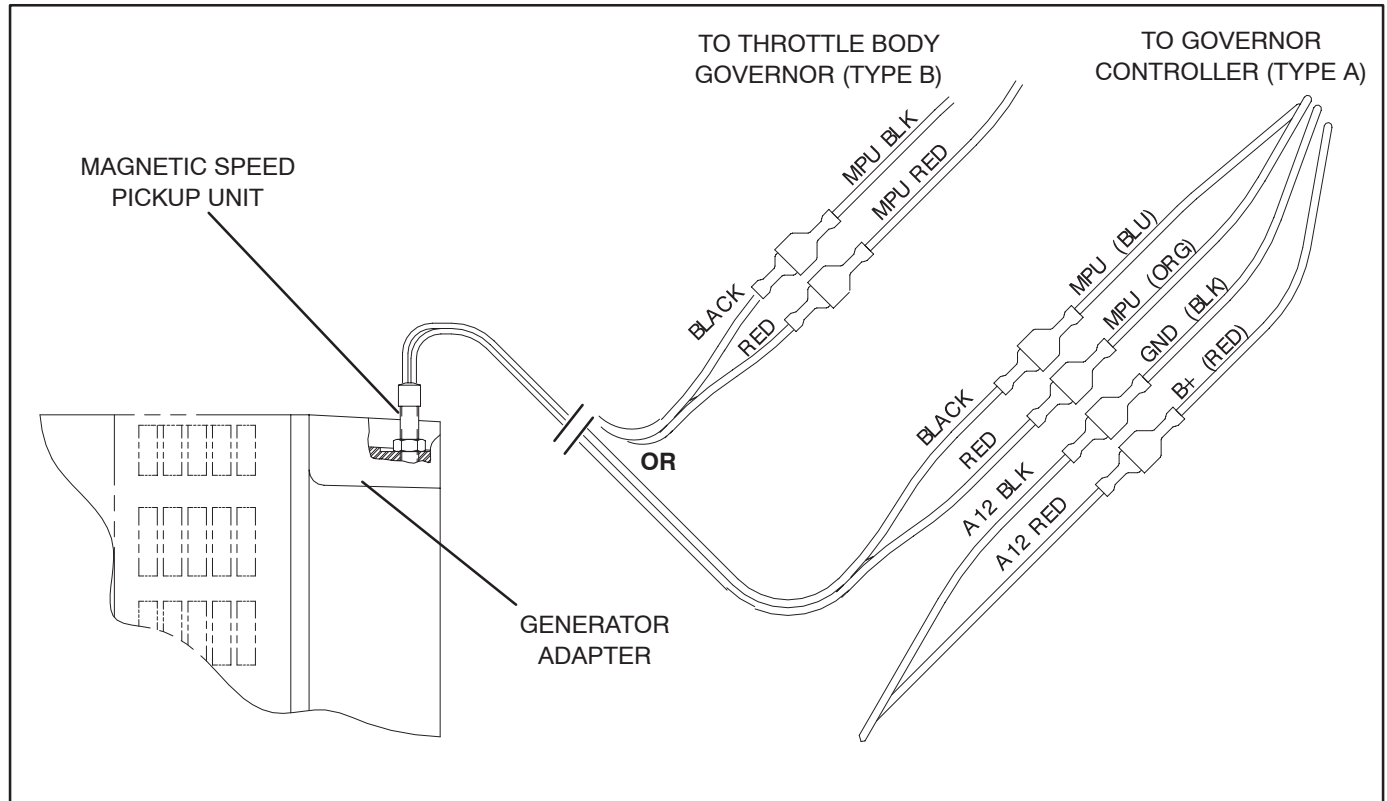

FIGURE 6-9. MAGNETIC SPEED PICKUP UNIT / GOVERNOR CONTROLLER CONNECTIONS

INITIAL SECONDARY REGULATOR ADJUSTMENT

Table 6-1 provides the approximate initial settings for the Model RZ secondary regulators used in the fuel system. If necessary, adjust the gas mixture, the governor linkage, magnetic speed pickup unit and the governor controller as instructed in this section before adjusting the regulator. Also, make sure

fuel supply pressure is adequate (7 to 13.5 inches WC (1.7 to 3.4 kPa). If the regulator is not properly adjusted, the set may not start, cause excessive crank time before starting, or lack power.

If the set does not start after adjustment of regulator, turn adjustment screw clockwise 1/2 turn and retry. Repeat until engine starts and properly operates under all load conditions.

TABLE 6-1. INITIAL SECONDARY REGULATOR ADJUSTMENT
(Distance from top of regulator to top of set screw)

MODEL/HZ	NG	LPG VAPOR	LPG LIQUID
GGFD, GGFE			
60 HZ	12.1 mm	11.75 mm	12.0 mm
50 HZ	12.1 mm	11.35 mm	12.0 mm
GGHE, GGHF			
60 HZ	13.35 mm	11.2 mm	12.0 mm
50 HZ	12.7 mm	10.8 mm	12.0 mm
GGHG, GGHH			
60 HZ	15.9 mm	14.9 mm	15.9 mm
50 HZ	14.6 mm	10.8 mm	12.0 mm

FUEL CONVERSION (NG TO LPV OR LPV TO NG)

Tables 6-2 and 6-4 indicate the genset models that can be converted to NG or LPG vapor without modifying the fuel system plumbing. Note that not all models can be converted to NG (e.g., GGHE), as indicated in Table 6-2. A fuel conversion kit would be required for this conversion.

Adjustment of the secondary regulator (Figure 6-7) and the manual main fuel valve (Figure 6-8) are the

only adjustments required to convert the fuel system to NG or LPG vapor.

After completing the following adjustments, it will be necessary to start the generator set and fine tune these adjustments. Refer to the appropriate fuel system adjustment procedures in this section.

Secondary Regulator Adjustment

If the factory setting has been changed/lost, set the adjustment screw as indicated in Table 6-1. If the factory setting has not been changed, refer to Table 6-2 to adjust regulator for desired fuel.

**TABLE 6-2. SECONDARY REGULATOR ADJUSTMENT
(FROM FACTORY SETTING)**

MODEL/HZ	CONVERT TO NG	CONVERT TO LPG VAPOR
GGFD, GGFE		
60 HZ	1/4 TURN CW	1/4 TURN CCW
50 HZ	1/2 TURN CW	1/2 TURN CCW
GGHE, GGHF		
60 HZ	N/A	1 1/8 TURN CCW
50 HZ	N/A	1 TURN CCW

Manual Main Fuel Valve Adjustment

If the factory setting has been changed/lost, set the adjustment screw as indicated in Table 6-3. To adjust, the main screw setting can be measured from

the opposite side (bottom) of the hex body or from the hex body surface next to the lock nut; Table 6-3 provides both dimensions.

If the factory setting has not been changed, refer to Table 6-4 to adjust main fuel valve for desired fuel.

TABLE 6-3. INITIAL MAIN FUEL VALVE ADJUSTMENT

MODEL	BOTTOM OF HEX	TOP OF HEX
GGFD, GGFE		
NG	49.0 mm	17.2
LPG VAPOR/LIQUID	46.3 mm	14.5 mm
GGHE, GGHF		
NG	50.8 mm	19.0 mm
LPG VAPOR/LIQUID	47.7 mm	16.0 mm

**TABLE 6-4. MAIN FUEL VALVE ADJUSTMENT
(FROM FACTORY SETTING)**

MODEL/HZ	CONVERT TO NG	CONVERT TO LPG VAPOR

GGFD, GGFE 50/60 HZ	3 3/8 TURNS CCW	3 3/8 TURNS CW
GGHE, GGHF 50/60 HZ	N/A	3 TURNS CW

VERIFY OVERSPEED FAULT DETECTION

To make sure that the genset control system can sense an overspeed condition, the RPM of the engine must be manually increased to the following overspeed shut down range:

50/60 Hz "Type A" Sets 2250 ±30 RPM

50/60 Hz "Type B" Sets 2400 ±30 RPM

For "Type A" gensets, move the throttle lever/linkage to increase RPM to the overspeed shutdown range.

For "Type B" gensets, the cover on the throttle body (Figure 6-10) must be removed to access the throttle shaft. Remove the two screws that secure the cover to the throttle body and remove cover.

With the cover removed, use specially designed tool (P/N 420-0604) to turn the end of the throttle shaft.

With genset operating (no load), slowly rotate the shaft clockwise until the engine RPM reaches the overspeed limit and shuts down the genset.

Replace the throttle body cover after completing test.

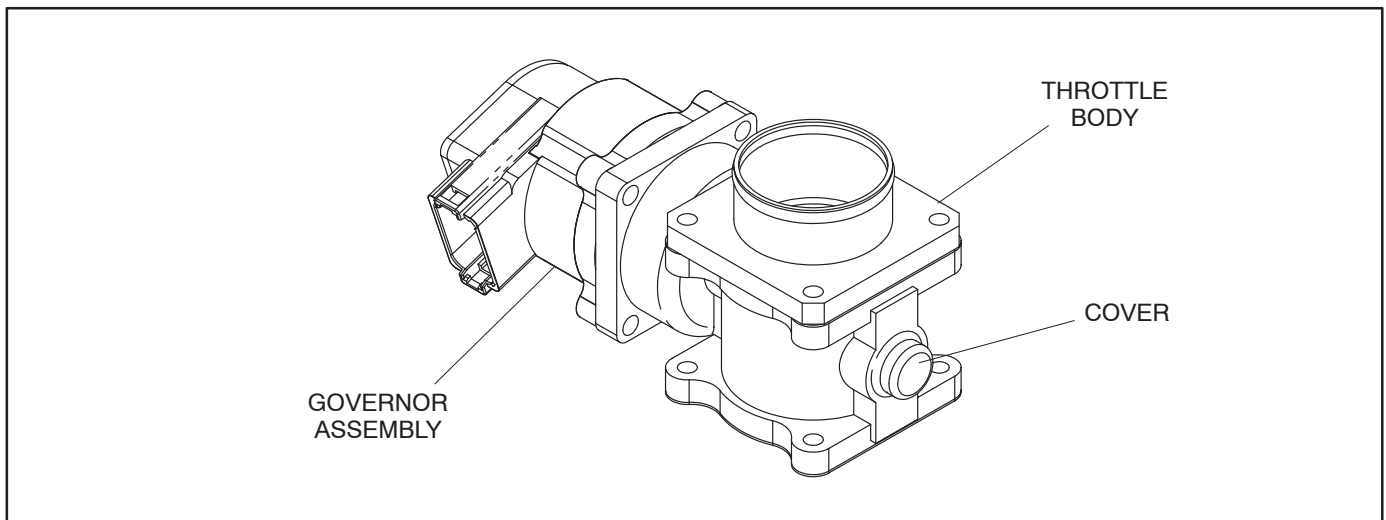

FIGURE 6-10. THROTTLE BODY/GOVERNOR ASSEMBLY (TYPE B)

7. Wiring Diagrams

This section consists of the schematic and connection wiring diagrams referenced in the text. The following drawings are included:

GENERAL

- Page 7-2, Generator Reconnection Diagram, Sheet 1
- Page 7-3, Generator Reconnection Diagram, Sheet 2
- Page 7-4, AC Control Wiring Diagram
- Page 7-5, Voltage Regulator Installation (PMG-Excited Generator)
- Page 7-6, Voltage Regulator Installation (Shunt-Excited Generator)
- Page 7-7, DC Control Wiring (Sheet 1 of 8)
- Page 7-8, DC Control Wiring (Sheet 2/3 of 8)
- Page 7-9, DC Control Wiring (Sheet 4 of 8)
- Page 7-10, DC Control Wiring (Sheet 5 of 8)
- Page 7-11, DC Control Wiring (Sheet 6 of 8)
- Page 7-12, DC Control Wiring (Sheet 7 of 8)
- Page 7-13, DC Control Wiring (Sheet 8 of 8)
- Page 7-14, Auxiliary Relay Board (ARB)
- Page 7-15, Typical Customer Connections At The Engine Control Monitor (ECM)
- Page 7-16, V6 Engine Harness (Spec A)
- Page 7-17, V6 Engine Harness (Spec B)
- Page 7-18, V6 Engine Harness (Spec C)
- Page 7-19, V10 Naturally Aspirated Engine Harness (TQ-125 Gov) (Spec A)
- Page 7-20, V10 (Turbo/Naturally Aspirated) Engine Harness (Low Emissions)
- Page 7-21, V10 (Turbo/Naturally Aspirated) Engine Harness (E-Control Ignition)

3 PHASE RECONNECTABLE, 12 LEAD

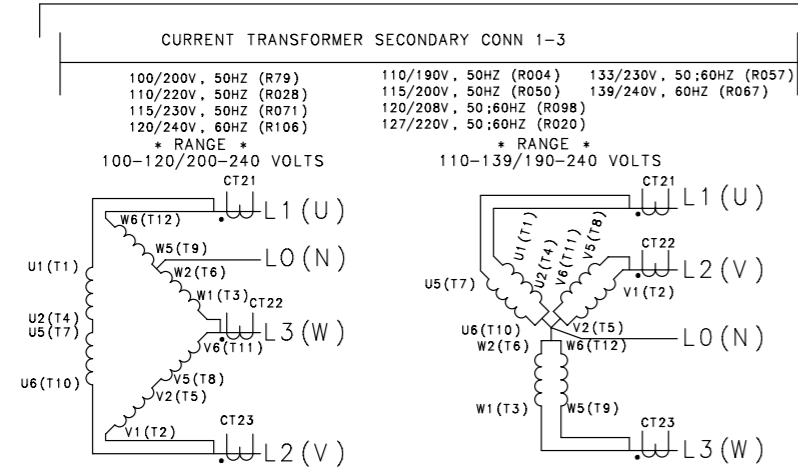

SERIES DELTA
3 PHASE 4 WIRE
OUTPUT TERMINALS
U.V.W.N.

PARALLEL STAR
3 PHASE 4 WIRE
OUTPUT TERMINALS
U.V.W.N.

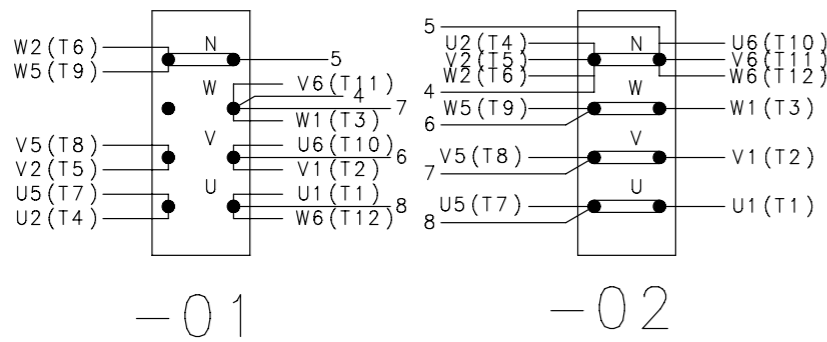

CURRENT TRANSFORMER SECONDARY CONN 1-2
220/380V, 50:60HZ (R099) 200/346V, 50HZ (R068)
260/450V, 50:60HZ (R109) 230/400V, 50HZ (R029)
240/416V, 50:60HZ (R003) 277/480V, 60 HZ (R002)
255/440V, 50HZ (R023) 266/460V, 60HZ (R027)
* RANGE *
220-277/380-480 VOLTS

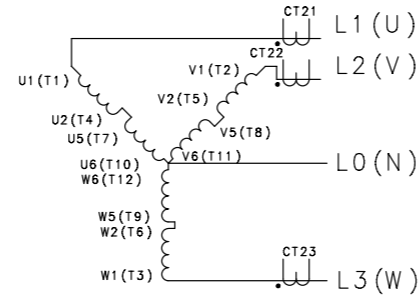

SERIES STAR
3 PHASE 4 WIRE
OUTPUT TERMINALS
U.V.W.N.

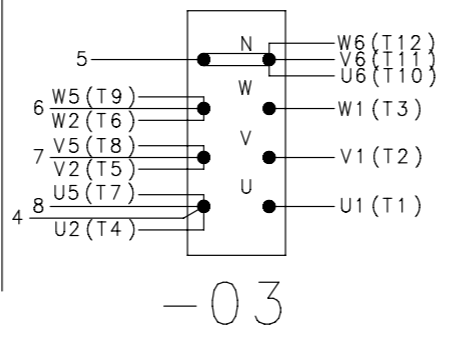

1 PHASE RECONNECTABLE, 12 LEAD

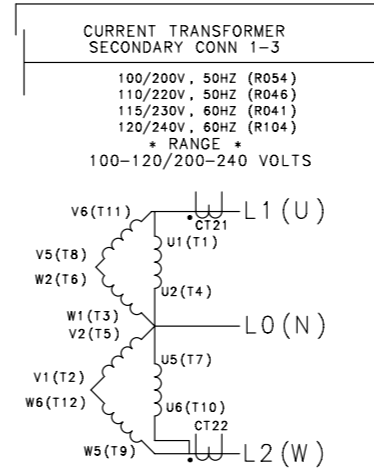

DOUBLE DELTA
1 PHASE 3 WIRE
OUTPUT TERMINALS
U.W. CENTER TAP N.

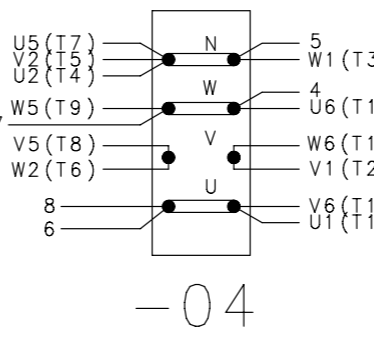

1 PHASE NON-RECONNECTABLE, 4 LEAD

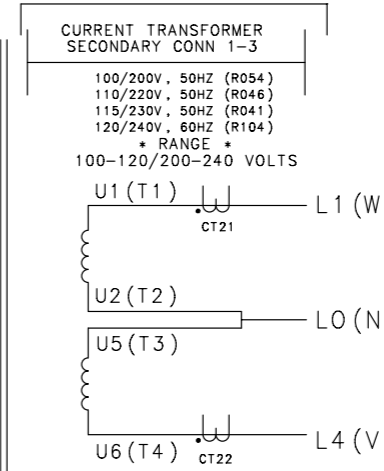

1 PHASE 3 WIRE
OUTPUT TERMINALS
W, V, CENTER TAP N

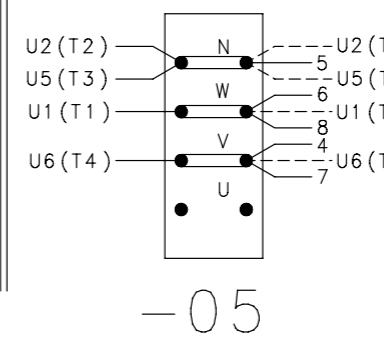

THIS IS A REPRESENTATIVE (GENERIC) SCHEMATIC/WIRING DIAGRAM. FOR TROUBLESHOOTING, REFER TO THE WIRING DIAGRAM PACKAGE THAT WAS INCLUDED WITH YOUR GENSET.

NOTES:

1. UVW PHASE SEQUENCE WITH C.W. ROTATION FACING DRIVE END.
2. 347/600 VOLTS - IF VOLTAGE REGULATOR SX440 ONAN P/N 300-3607 IS SPECIFIED, CONNECT GENERATOR TAP STATOR LEADS 7 & 8 TO VR21-P2 & VR21-P3 RESPECTIVELY. INSULATE AND TIE #6 LEAD BACK.
3. 347/600 VOLTS - IF VOLTAGE REGULATOR ONAN P/N 300-3606 INSULATE AND TIE BACK GENERATOR TAP STATOR LEADS 6, 7 & 8.
4. 240/480 VOLTS - IF VOLTAGE REGULATOR SX440 ONAN P/N 300-3607 IS SPECIFIED, CONNECT LEAD FROM W6 (U) AND W5 (N) TO VR21-P2 AND VR21-P3 RESPECTIVELY.
5. 1 PHASE NON-RECONNECTABLE: LARGER KW GENSETS HAVE 8 OUTPUT TERMINALS SMALLER KW HAVE 4.
6. WHEN RECONNECTING GENERATOR LEADS, BOLTS SHOULD BE TORQUED AT 22 ±2 FT-LBS.
7. 347/600 VOLTS - IF VOLTAGE REGULATOR SX460 ONAN PART #300-4830 IS SPECIFIED, CONNECT STATOR TAP LEAD 8 TO CB21-1 ON CONTROL PANEL. CONNECT TAP LEADS 6 & 7 TO AVR-6 & 7.
8. WHEN NON-DETECTOR CONTROLS ARE USED AT 600V
 - 8.1 SX460 AVR
CONNECT STATOR TAP LEAD 8 TO CB21-1 ON CONTROL PANEL. CONNECT TAPS 6 & 7 TO AVR
 - 8.2 MX321 AVR WITHOUT AC METERS:
CONNECT STATOR TAP LEADS 6, 7, & 8 TO ISOLATION XFMR BOARD T30-INPUT-6, 7, & 8.
 - 8.3 MX321 WITH AC METERS:
INSULATE AND TIE BACK STATOR TAP LEADS 6, 7, & 8.

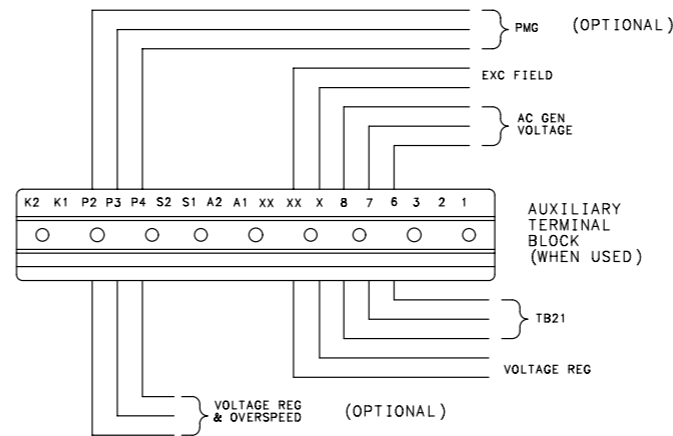

CONTROL INPUT "DETECTOR"				
CONTROL INPUT TB21	SERIES DELTA	PARALLEL STAR	SERIES STAR	DOUBLE DELTA
22	8	8	8	8
23	7	7	7	7
24	4	4	4	4
25	6	6	6	6
26	5	5	5	5
JUMPER	—	—	—	—

No. 625-3061 sh 1 of 2
Rev. G Sys: CADAM
Modified 5-96

3 PHASE RECONNECTABLE

CURRENT TRANSFORMER
SECONDARY CONN 1 - 2

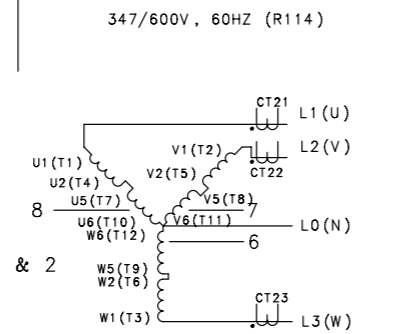

SEE NOTE 1 & 2

SERIES STAR
3 PHASE 4 WIRE
OUTPUT TERMINALS
U.V.W.N.

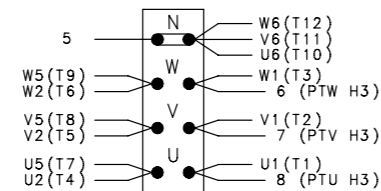

TRANSFORMER

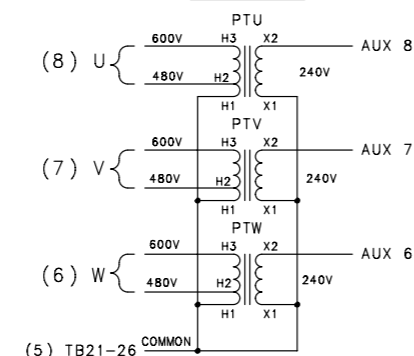

REFERENCE ONLY
P/N 319-1246

NOTE: JUMPER TB21-21 TO TB21-24
IN THE CONTROL

-06

3 PHASE NON-RECONNECTABLE

CURRENT TRANSFORMER SECONDARY CONN 1 - 2

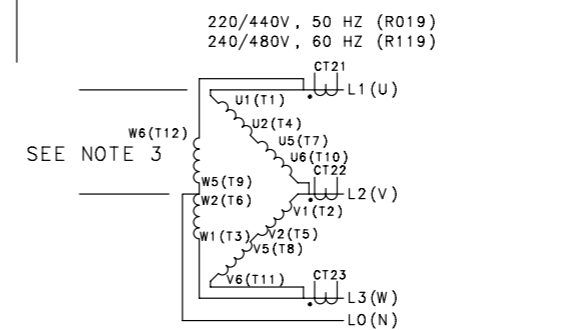

SEE NOTE 3

SERIES DELTA
3 PHASE 4 WIRE
OUTPUT TERMINALS
U.V.W.N.

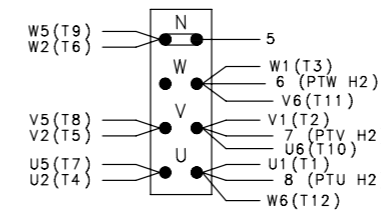

TRANSFORMER

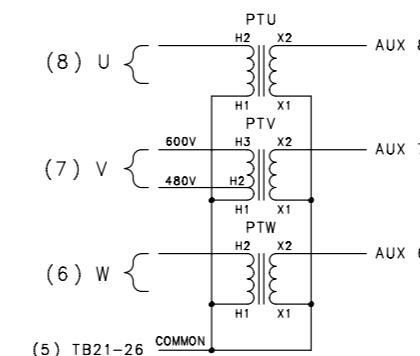

REFERENCE ONLY
P/N 319-1246

NOTE: JUMPER TB21-21 TO TB21-24
IN THE CONTROL

-07

THIS IS A REPRESENTATIVE (GENERIC) SCHEMATIC/WIRING DIAGRAM. FOR TROUBLESHOOTING, REFER TO THE WIRING DIAGRAM PACKAGE THAT WAS INCLUDED WITH YOUR GENSET.

NOTES:

- 347/600 VOLTS - IF VOLTAGE REGULATOR SX440 ONAN P/N 300-3607 IS SPECIFIED, CONNECT GENERATOR TAP STATOR LEADS 7 & 8 TO VR21-P2 & VR21-P3 REPECTIVELY. INSULATE AND TIE #6 LEAD BACK.
- 347/600 VOLTS - IF VOLTAGE REGULATOR ONAN P/N 300-3606 IS SPECIFIED, INSULATE AND TIE BACK GENERATOR TAP STATOR LEADS 6, 7 & 8.
- 240/480 VOLTS - IF VOLTAGE REGULATOR SX440 ONAN P/N 300-3607 IS SPECIFIED, CONNECT LEAD FROM W6 (U) AND W5 (N) TO VR21-P2 AND VR21-P3 RESPECTIVELY.
- WHEN RECONNECTING GENERATOR LEADS, BOLTS SHOULD BE TORQUED AT 22 ±2 FT-LBS.
- 347/600 VOLTS - IF VOLTAGE REGULATOR SX460 ONAN PART #300-4830 IS SPECIFIED, CONNECT STATOR TAP LEAD 8 TO CB21-1 ON CONTROL PANEL. CONNECT TAP LEADS 6 & 7 TO AVR-6 & 7.
- WHEN NON-DETECTOR CONTROLS ARE USED AT 600V
 - SX460 AVR
CONNECT STATOR TAP LEAD 8 TO CB21-1 ON CONTROL PANEL. CONNECT TAPS 6 & 7 TO AVR
 - MX321 AVR WITHOUT AC METERS:
CONNECT STATOR TAP LEADS 6, 7, & 8 TO ISOLATION XFMR BOARD T30-INPUT-6, 7, & 8.
 - MX321 WITH AC METERS:
INSULATE AND TIE BACK STATOR TAP LEADS 6, 7, & 8.

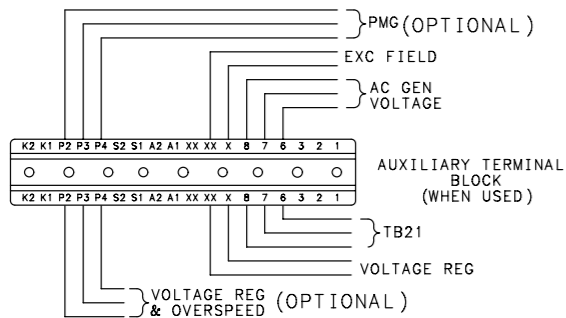

CONTROL INPUT "DETECTOR"			
6 OR 12 LEAD			
CONTROL INPUT TB21	AUX TERM CON	SERIES STAR 347/600V	SERIES DELTA 240/480V
22	8	8	8
23	7	7	7
24	-	-	-
25	6	6	6
26	-	5	5
JUMPER	-	21 - 24	21 - 24

SCHMATIC DIAGRAM

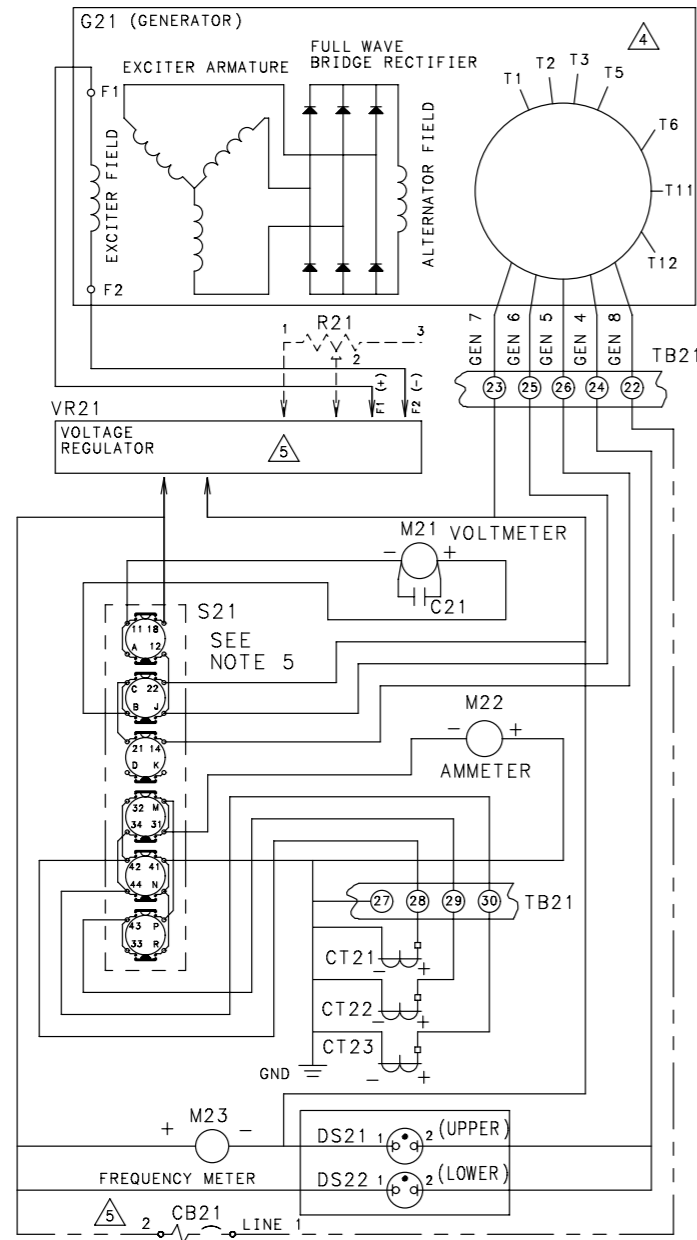

WIRING DIAGRAM

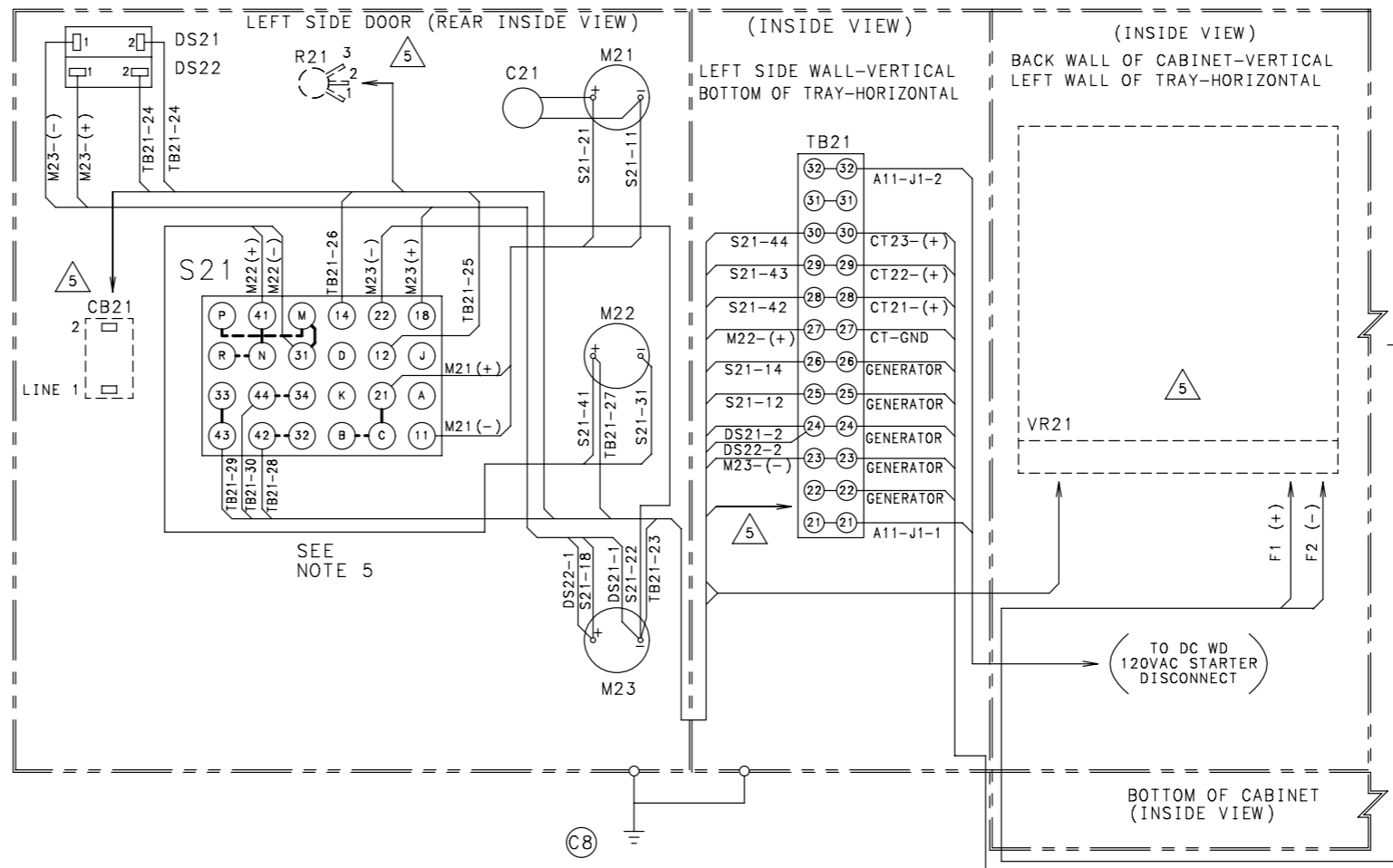

S21

POSITION	CONTACTS CLOSED				
L1-L2 30	11-18	C-22	32-M	44-N	33-R
L2-L3 30	A-12	C-22	44-N	42-41	43-P
L3-L1 30	11-18	B-J	34-31	42-41	33-R
L1-L0 30	11-18	21-14	44-N	42-41	33-R
OFF	—	—	44-N	42-41	33-R
L1-L2 10	11-18	C-22	32-M	44-N	33-R
L1-L2 10	11-18	C-22	44-N	42-41	43-P

TABULATION

DESIGNATION	WIRE COLOR
CT21-1	PNK/BLK
CT22-1	PRP/BLK
CT23-1	ORN/BLK
CT COMMON	GRY/BLK
GEN 4	LT GRN/BLK
GEN 5	TAN/BLK
GEN 6	RED/BLK
GEN 7	YEL/BLK
GEN 8	DK BLU/BLK

THIS IS A REPRESENTATIVE (GENERIC) SCHEMATIC/WIRING DIAGRAM. FOR TROUBLESHOOTING, REFER TO THE WIRING DIAGRAM PACKAGE THAT WAS INCLUDED WITH YOUR GENSET.

No. 612-6694 sh 2 of 3
Rev. K Sys: CADAM
Modified 3-01

AC CONTROL WIRING DIAGRAM



(-07 & -08, 600 V)
 (-05 & -06, <600 V)
 (-03 & -04, 600 V)

THIS IS A REPRESENTATIVE (GENERIC) SCHEMATIC/WIRING DIAGRAM. FOR TROUBLESHOOTING, REFER TO THE WIRING DIAGRAM PACKAGE THAT WAS INCLUDED WITH YOUR GENSET.

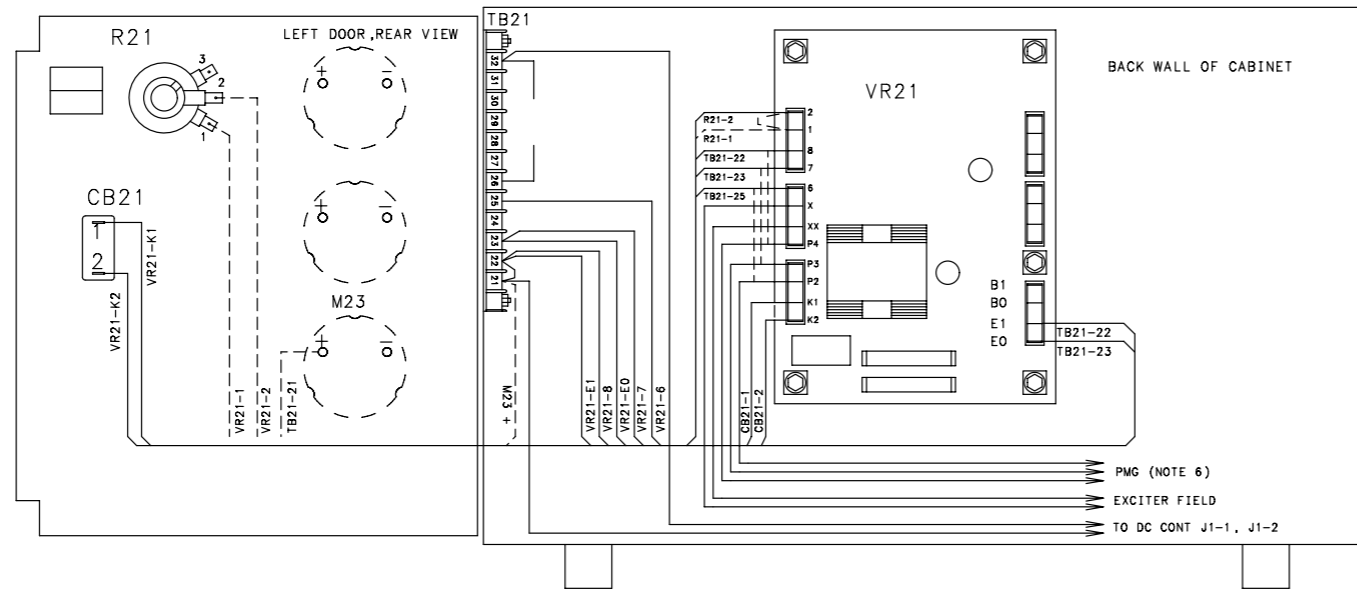

NOTES

1. DASHED LEADS INDICATE WHEN USED
2. REFER TO ILLUSTRATION DRAWING 539-0741
3. TIE EXTRA WIRE INTO HARNESS
4. FOR 1Ø GENERATOR OPERATION:
DISCONNECT LEAD FROM TB21-25 TO T30-IN-6 AND DISCARD.
MOVE LEAD END ON T30-OUT-6 TO VR21-8.
- 5.
6. PMG NOT USED WITH AVR SX421; -05 THRU -08.
GEN TAP LEADS 6,7 & 8 ARE CONNECTED DIRECTLY TO P2,P3 & P4 RESPECTIVELY ON 600V UNITS.
BELOW 600V UNITS USE JUMPER WIRES TO P2, P3 & P4.

(-01 & -02, <600V)

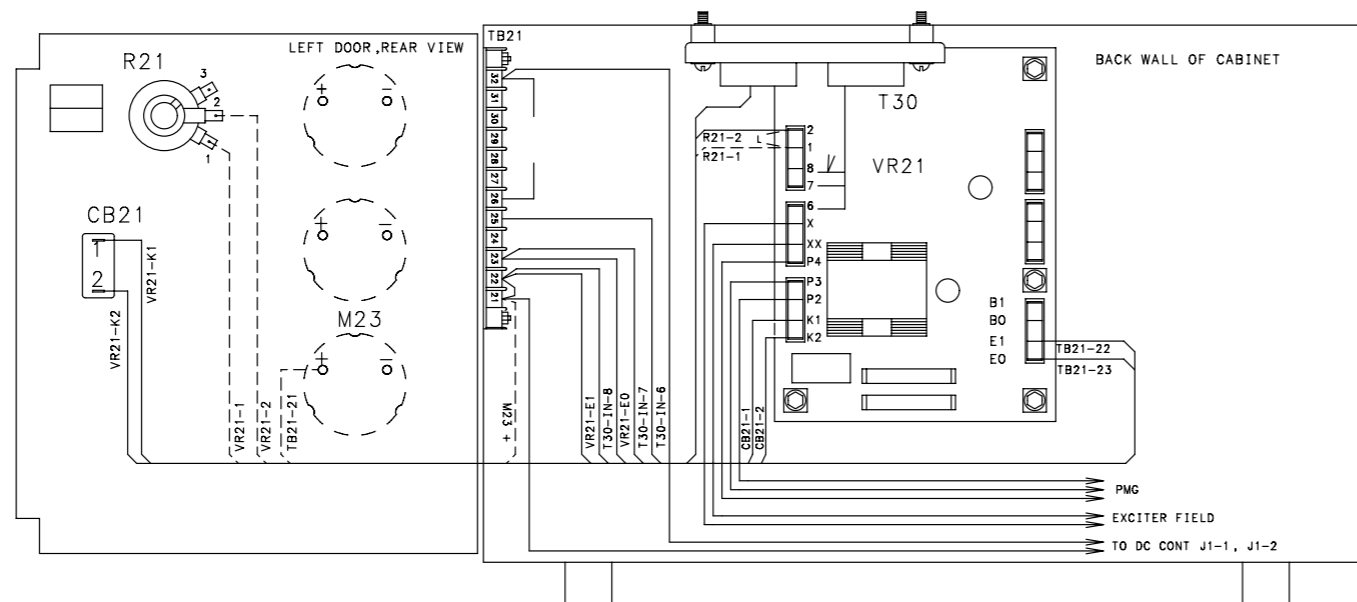

MX321
 SX421

No. 300-4890 sh 1 of 1
 Rev. L Sys: CADAM
 Modified 4-00

VOLTAGE REGULATOR INSTALLATION (PMG-EXCITED GENERATOR)

THIS IS A REPRESENTATIVE (GENERIC) SCHEMATIC/WIRING DIAGRAM. FOR TROUBLESHOOTING, REFER TO THE WIRING DIAGRAM PACKAGE THAT WAS INCLUDED WITH YOUR GENSET.

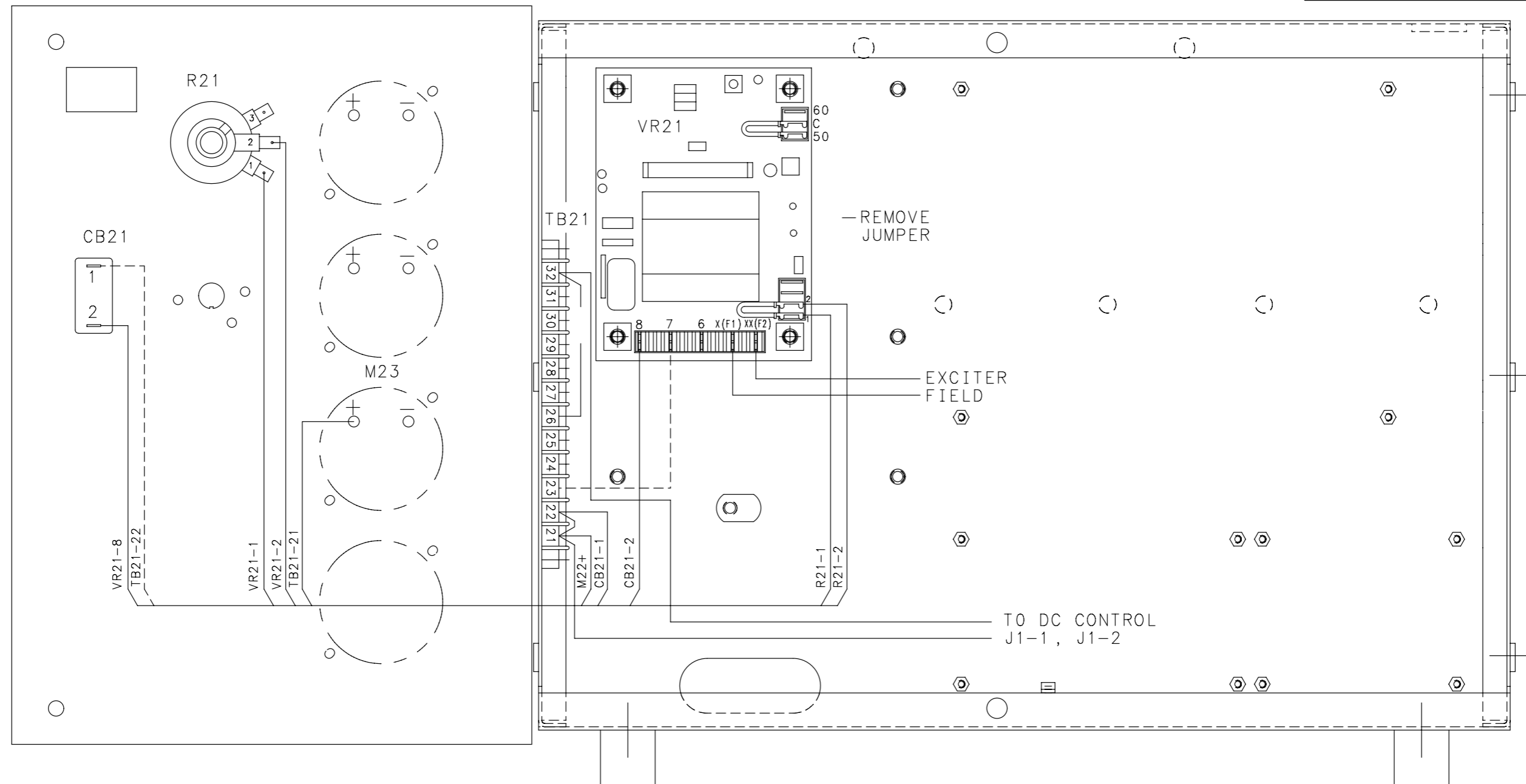

- NOTES:
1. REFER TO ILLUSTRATION DRAWING 539-0741.
 2. TIE EXTRA WIRE INTO HARNESS.

SX460

No. 300-4830 sh 1 of 1
 Rev. H
 Modified 3-00

VOLTAGE REGULATOR INSTALLATION (SHUNT-EXCITED GENERATOR)

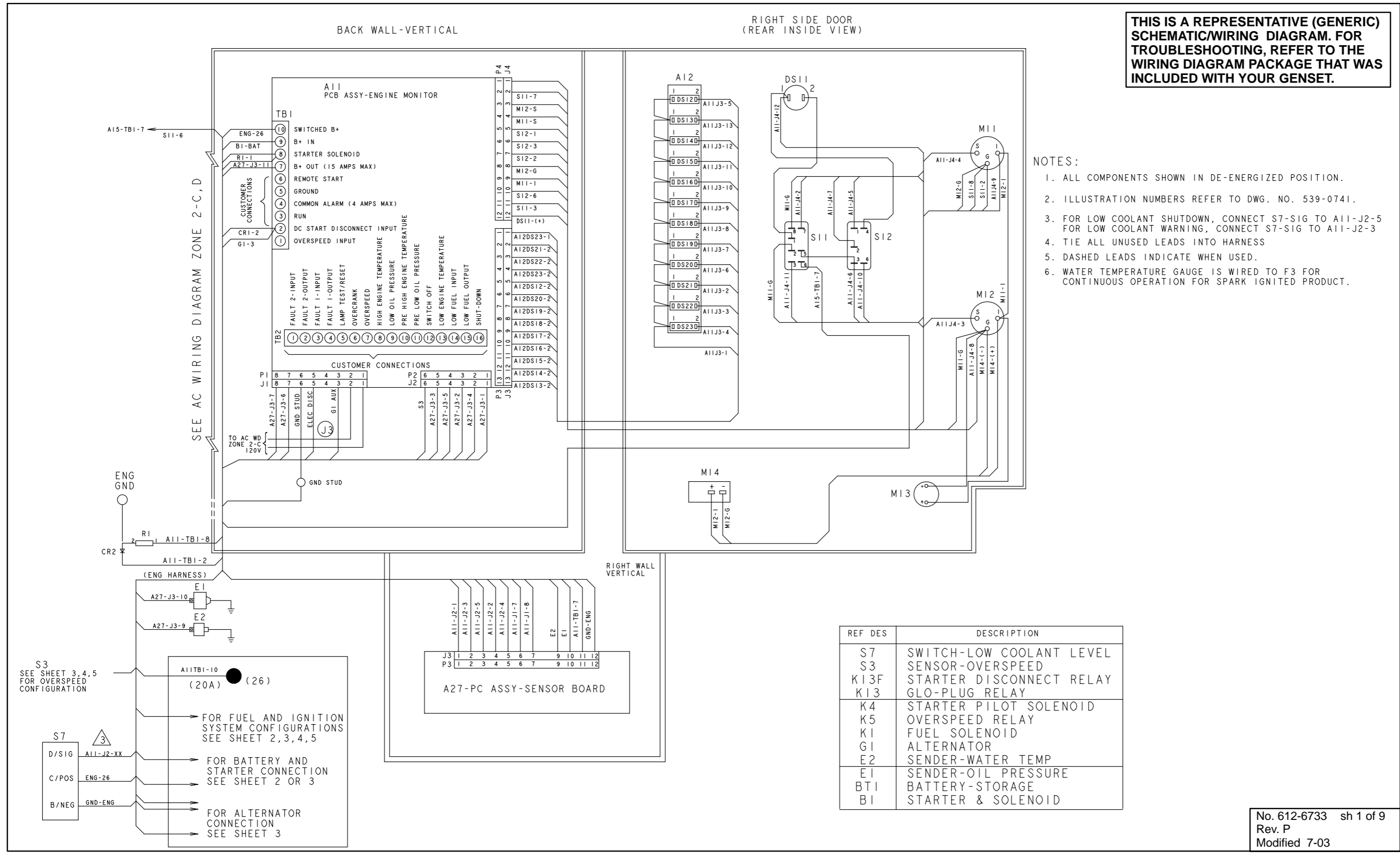

DC CONTROL WIRING DIAGRAM (SHEET 1 OF 8)

THIS IS A REPRESENTATIVE (GENERIC) SCHEMATIC/WIRING DIAGRAM. FOR TROUBLESHOOTING, REFER TO THE WIRING DIAGRAM PACKAGE THAT WAS INCLUDED WITH YOUR GENSET.

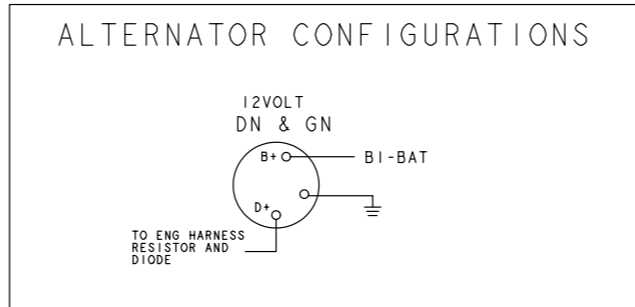
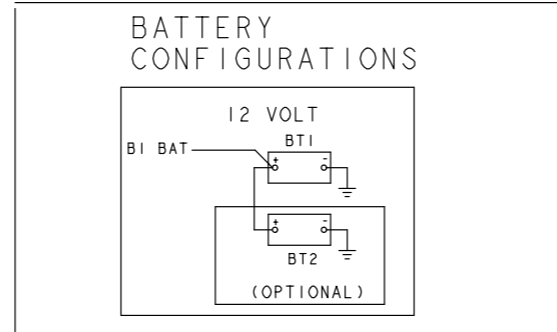
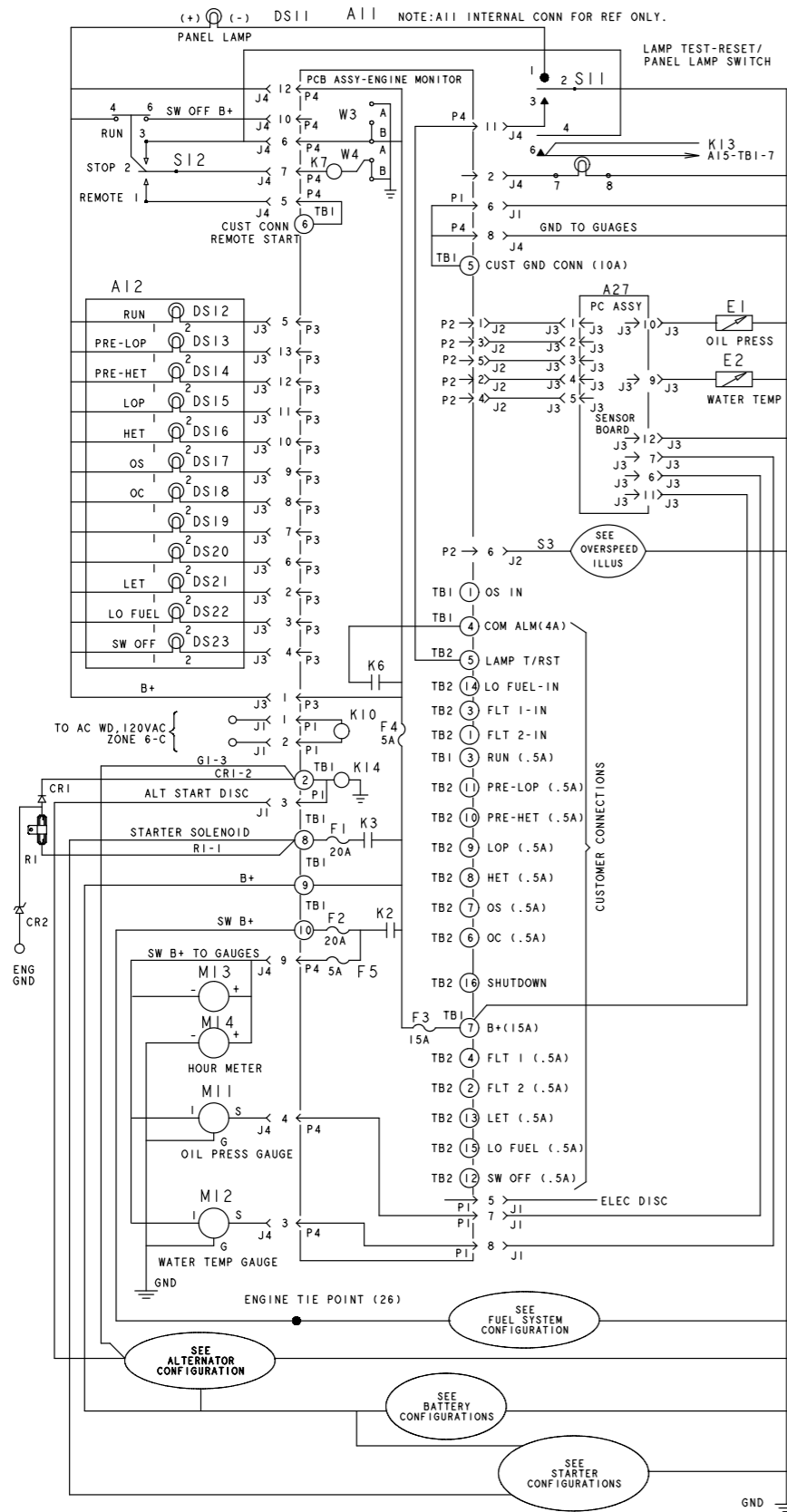

No. 612-6733 sh 2/3 of 9
Rev. P
Modified 7-03

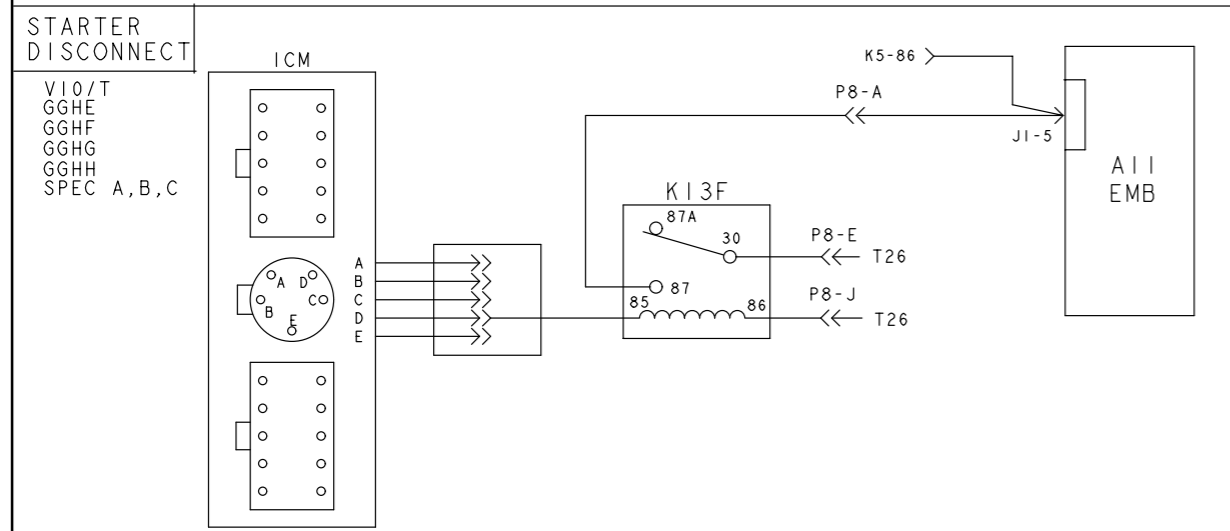
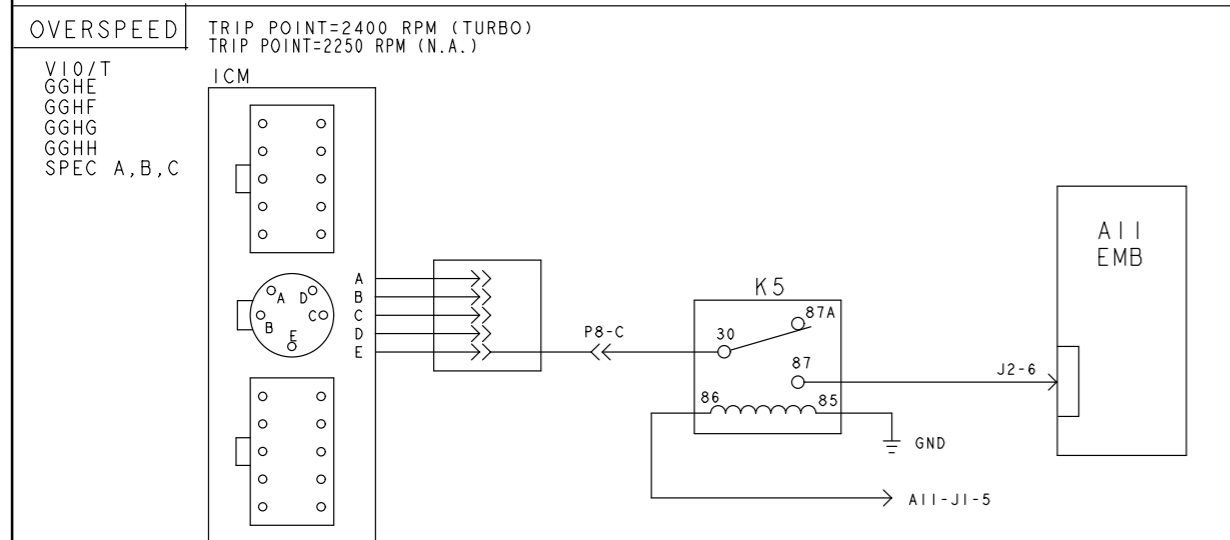
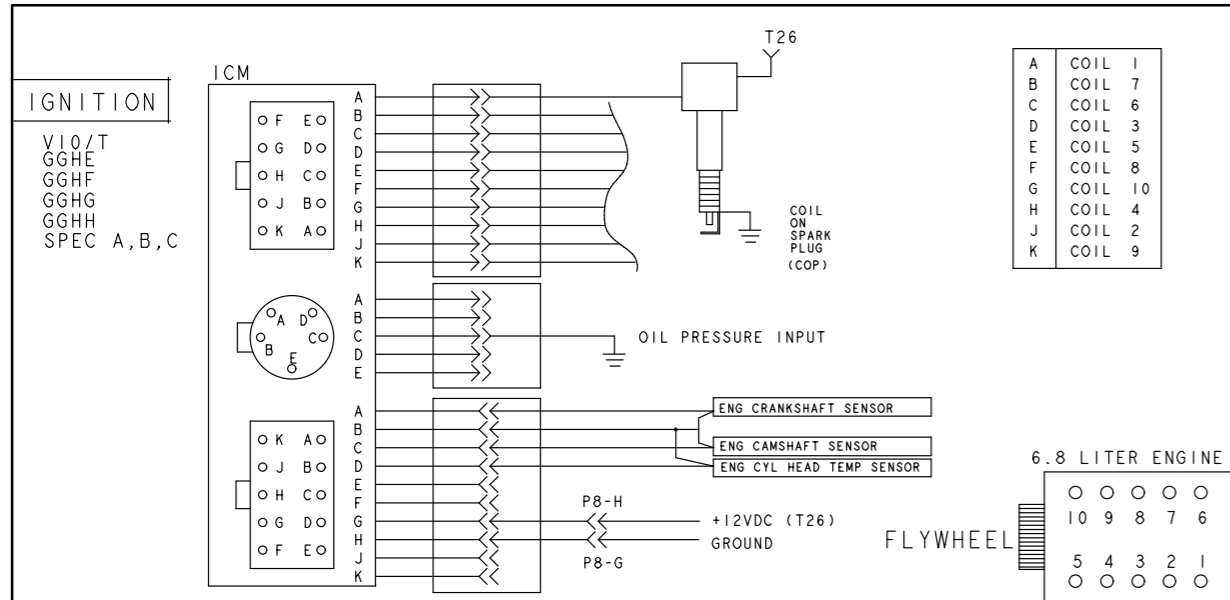

FUEL SELECT AND TIMING

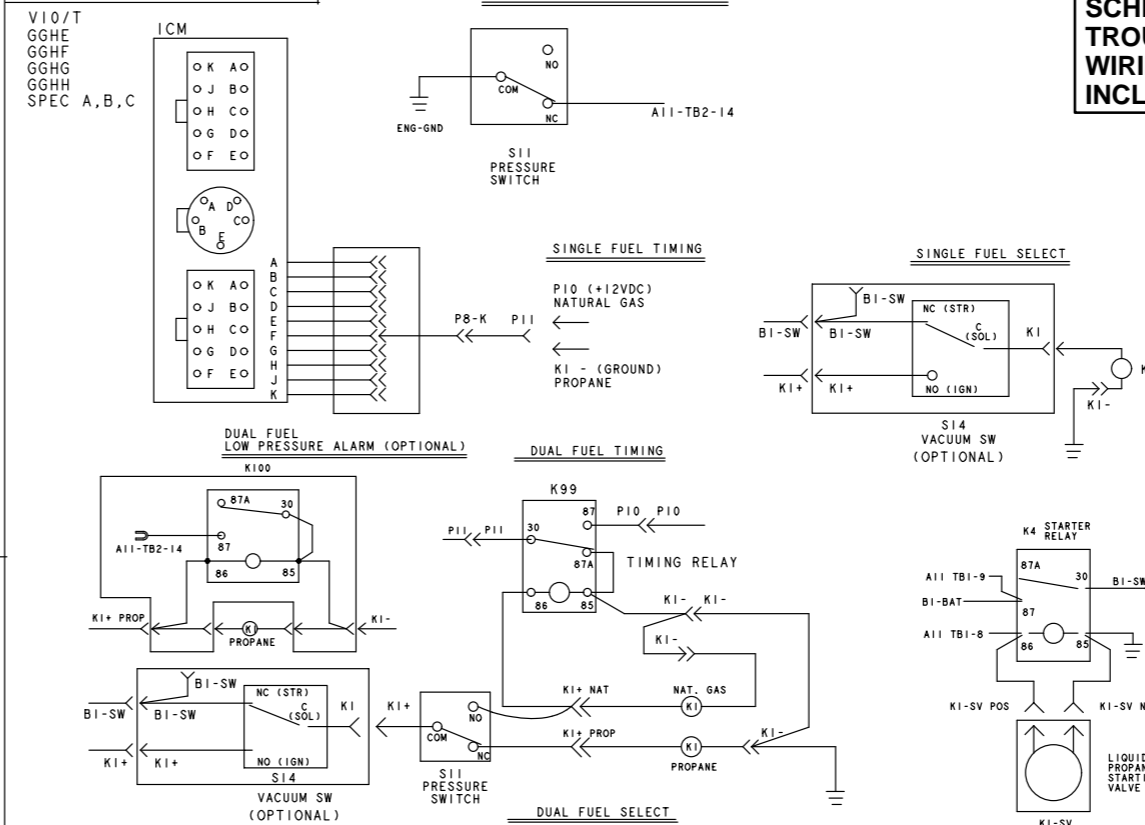

THIS IS A REPRESENTATIVE (GENERIC) SCHEMATIC/WIRING DIAGRAM. FOR TROUBLESHOOTING, REFER TO THE WIRING DIAGRAM PACKAGE THAT WAS INCLUDED WITH YOUR GENSET.

GOVERNOR

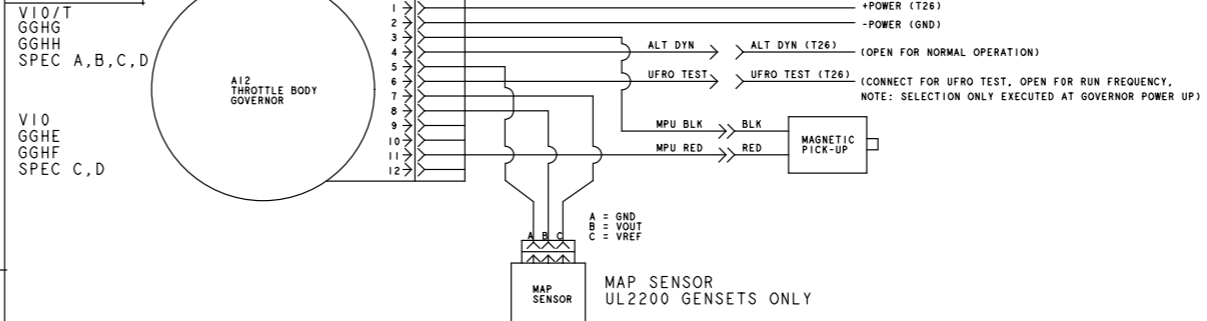

AIR/FUEL CONTROLLER OPTION

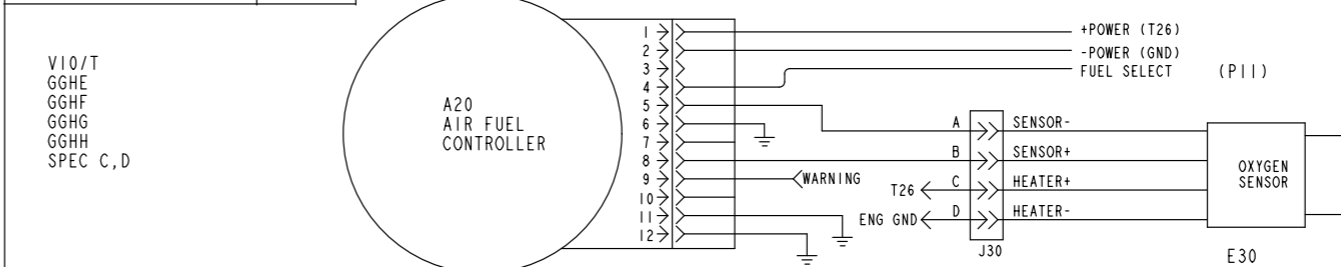

No. 612-6733 sh 4 of 8
Rev. P
Modified 7-03

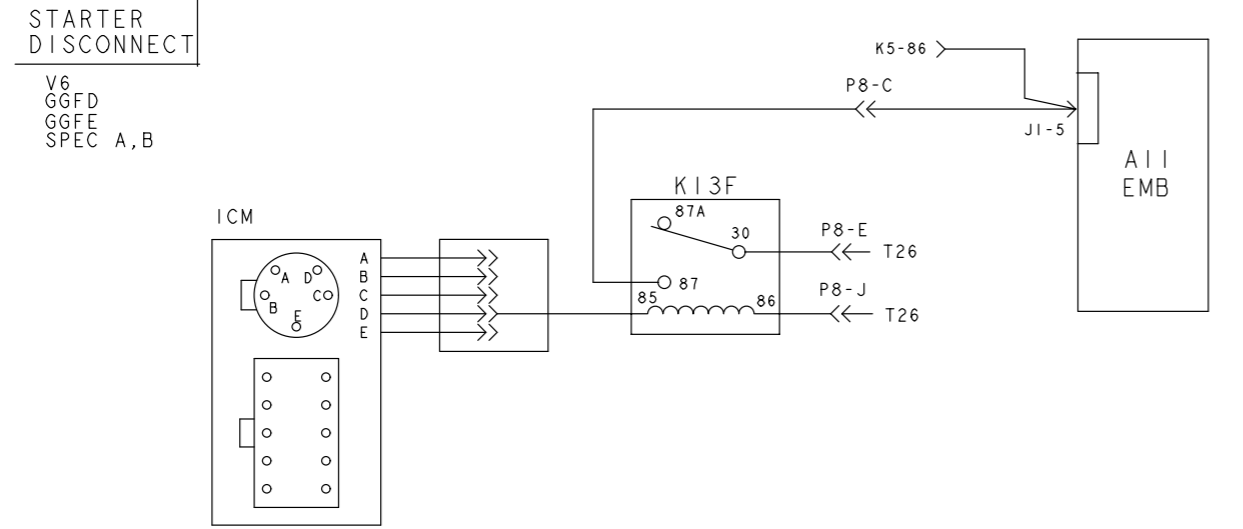
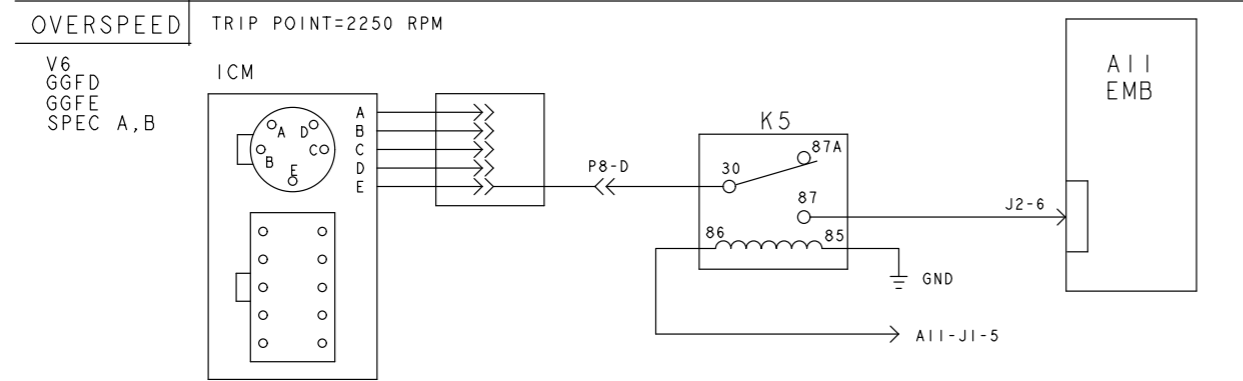
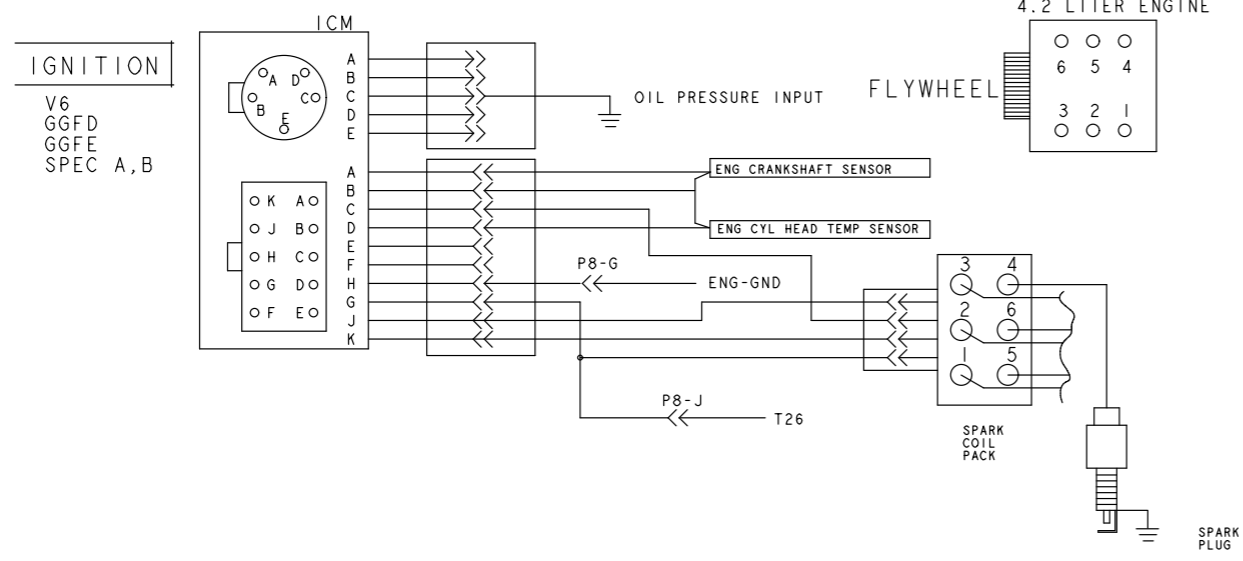

FUEL SELECT AND TIMING

V6
GGFD
GGFE
SPEC A,B

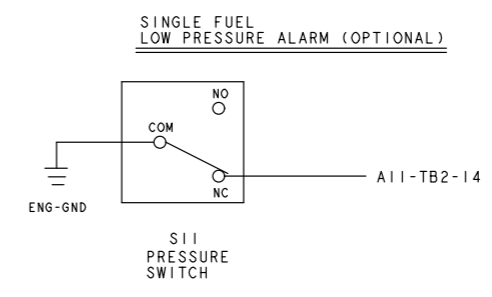
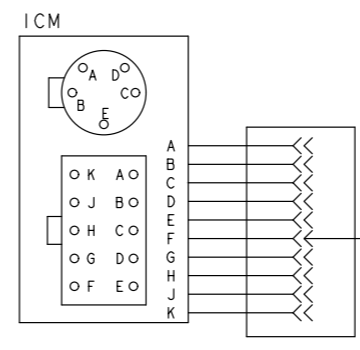

SINGLE FUEL TIMING

P10 (+12VDC)
NATURAL GAS
K1 - (GROUND)
PROPANE

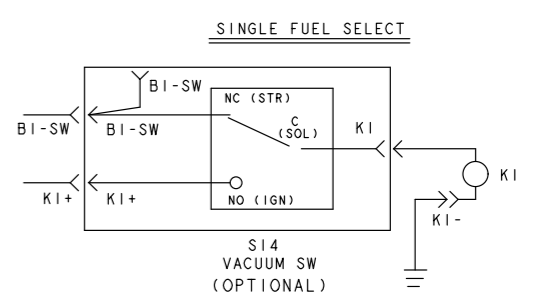

DUAL FUEL LOW PRESSURE ALARM (OPTIONAL)

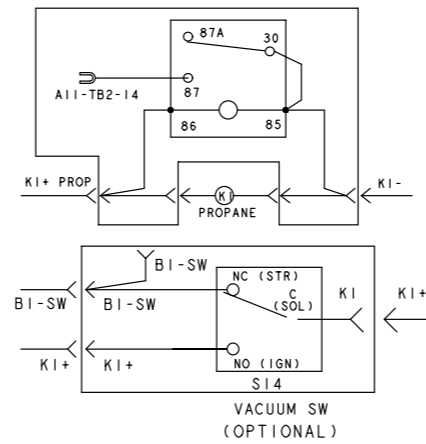

DUAL FUEL TIMING

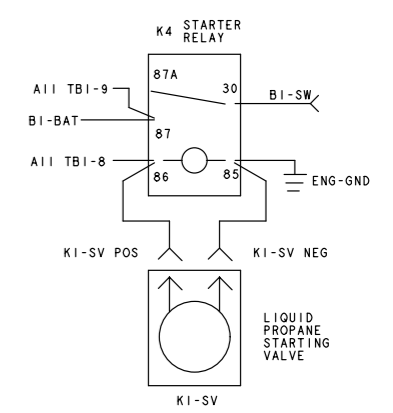
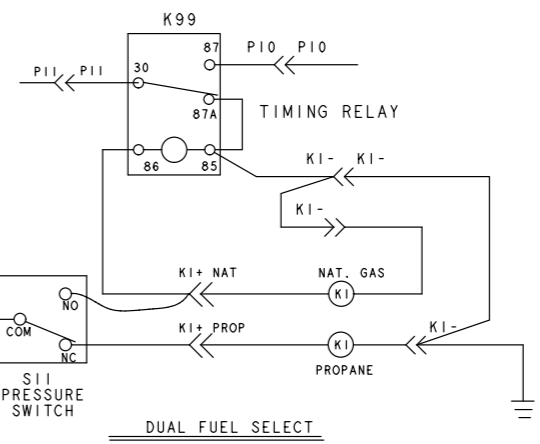

THIS IS A REPRESENTATIVE (GENERIC) SCHEMATIC/WIRING DIAGRAM. FOR TROUBLESHOOTING, REFER TO THE WIRING DIAGRAM PACKAGE THAT WAS INCLUDED WITH YOUR GENSET.

No. 612-6733 sh 5 of 9
Rev. P
Modified 6-03

THIS IS A REPRESENTATIVE (GENERIC) SCHEMATIC/WIRING DIAGRAM. FOR TROUBLESHOOTING, REFER TO THE WIRING DIAGRAM PACKAGE THAT WAS INCLUDED WITH YOUR GENSET.

GGHE
GGHF
GGHG
GGHH
SPEC D

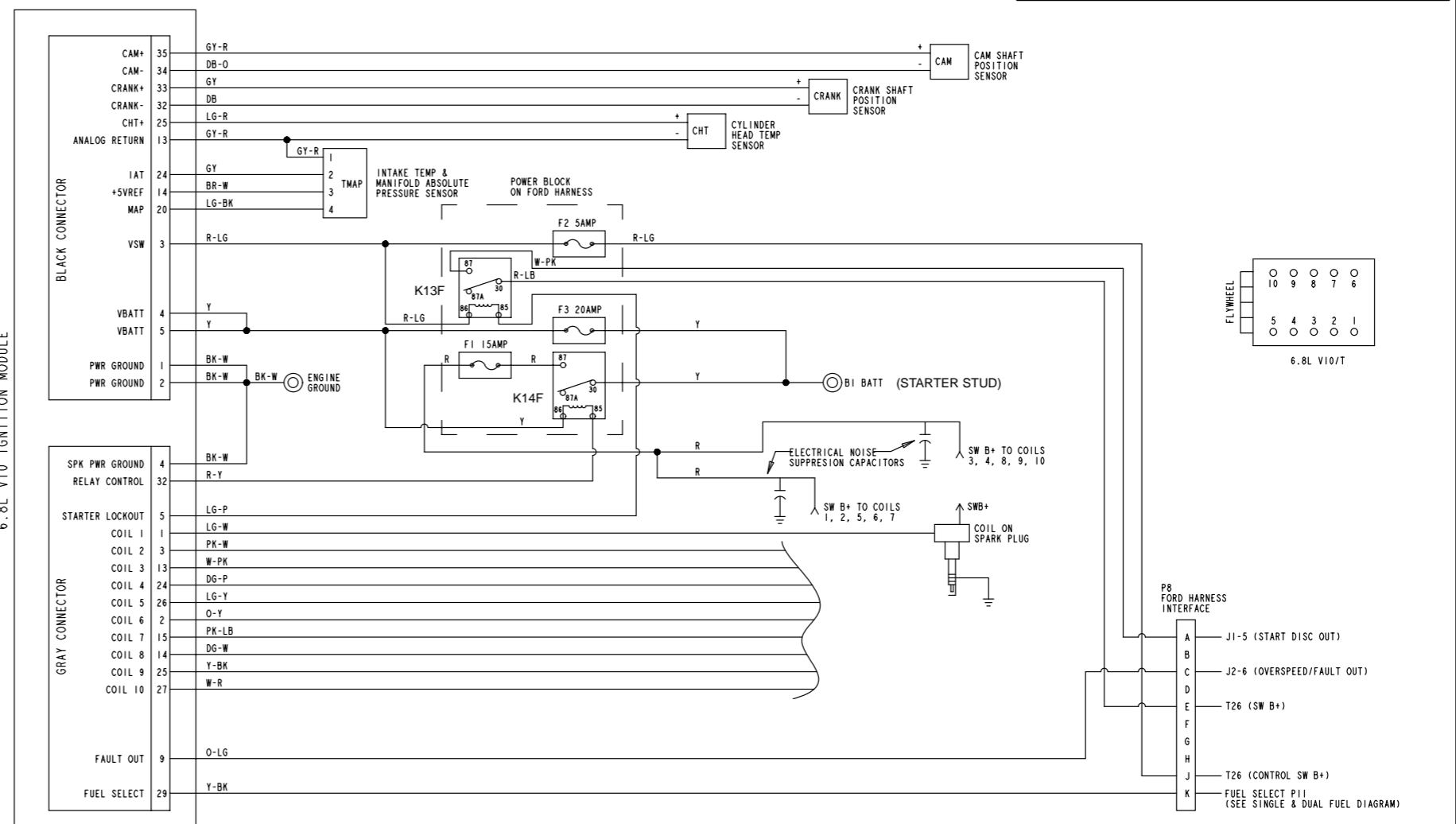

GGFD
GGFE
SPEC C
IGNITION CONTROL MODULE V6

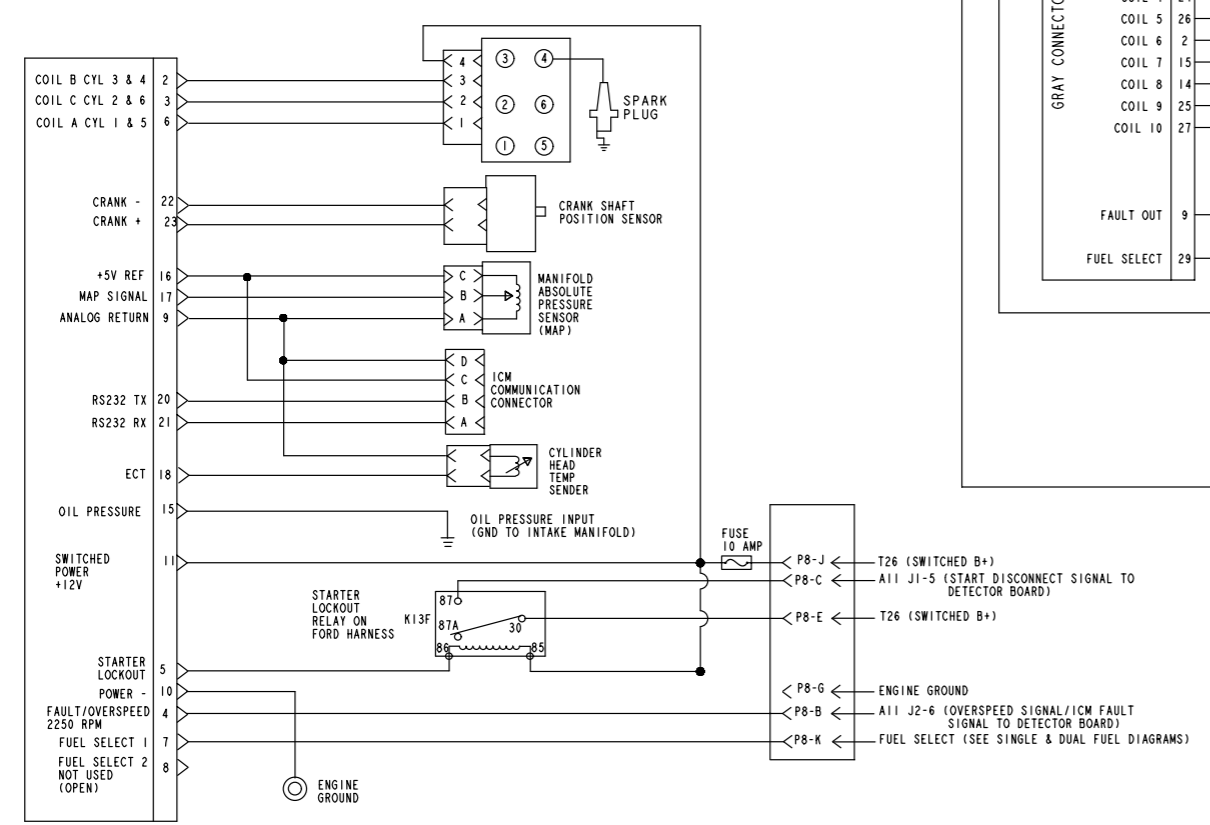

No. 612-6733 sh 6 of 9
Rev. P
Modified 7-03

THIS IS A REPRESENTATIVE (GENERIC) SCHEMATIC/WIRING DIAGRAM. FOR TROUBLESHOOTING, REFER TO THE WIRING DIAGRAM PACKAGE THAT WAS INCLUDED WITH YOUR GENSET.

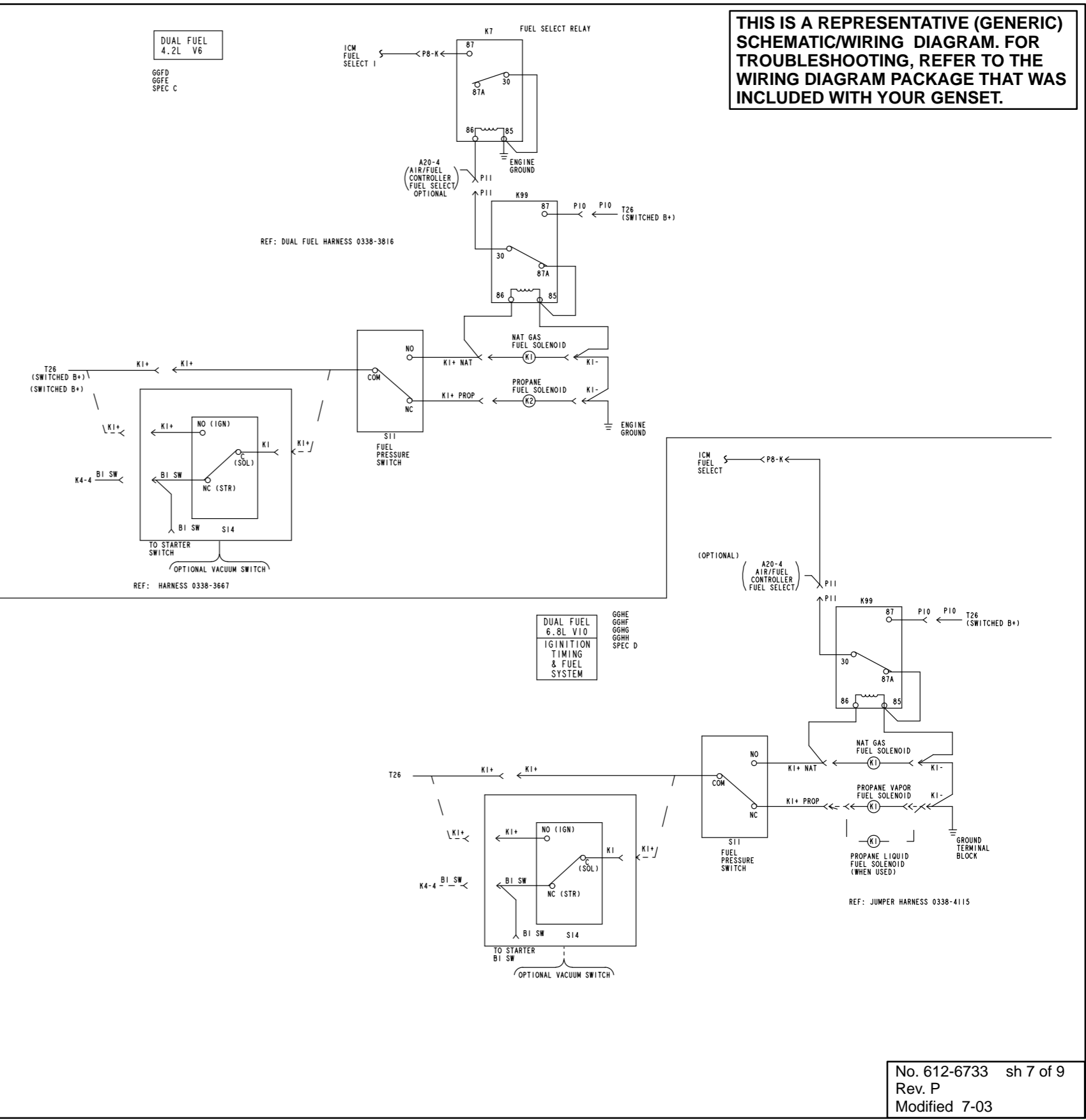
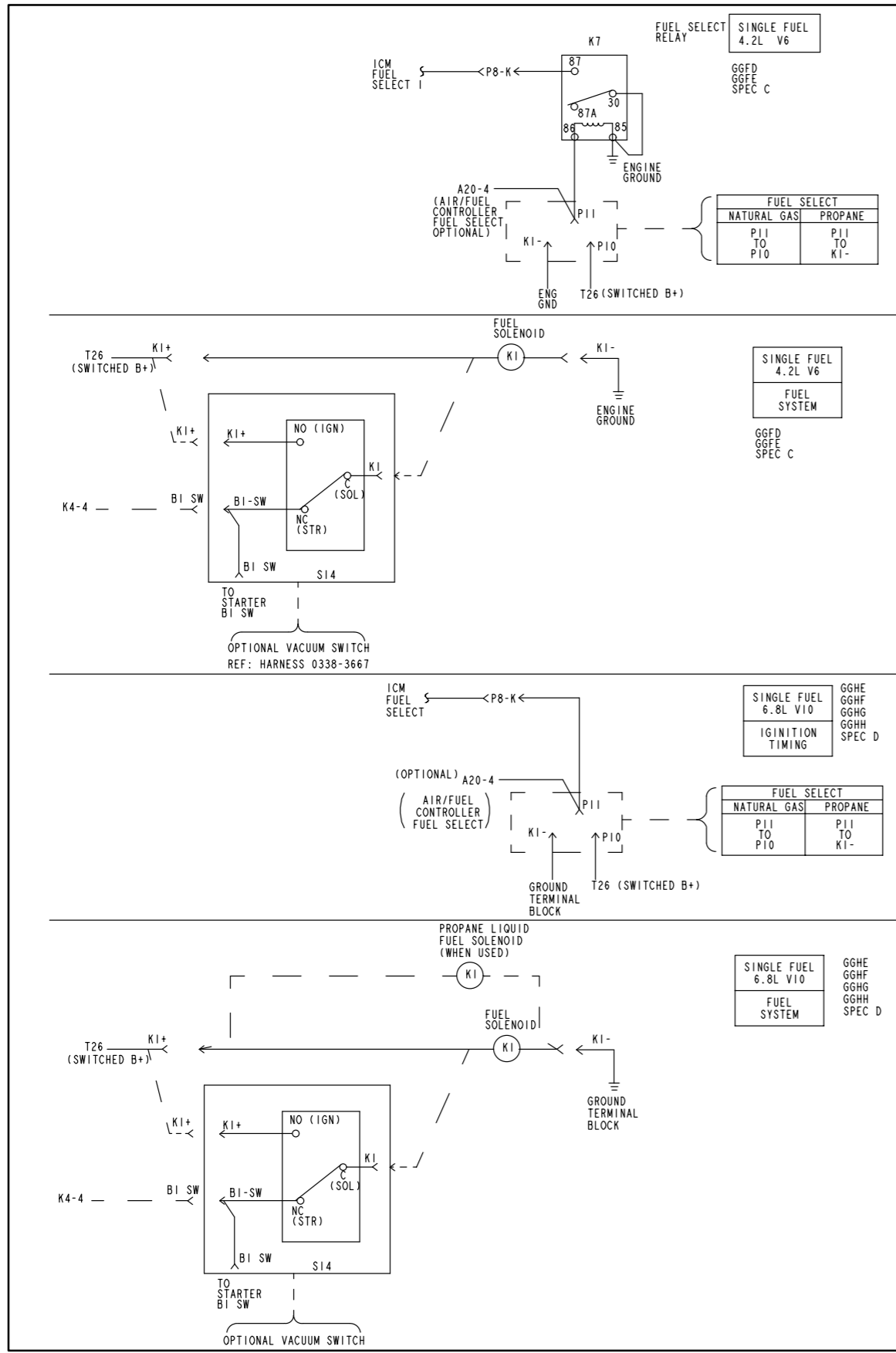

No. 612-6733 sh 7 of 9
 Rev. P
 Modified 7-03

SINGLE FUEL ALARM (OPTIONAL)

V6
GGFD
GGFE

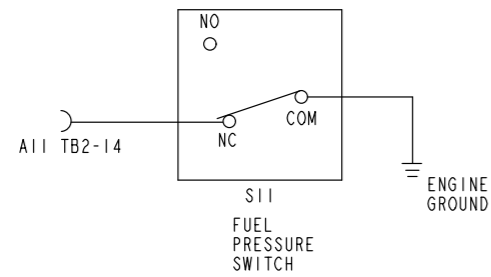

REF: HARNESS 0338-3740

DUAL FUEL ALARM (OPTIONAL)

V6
GGFD
GGFE

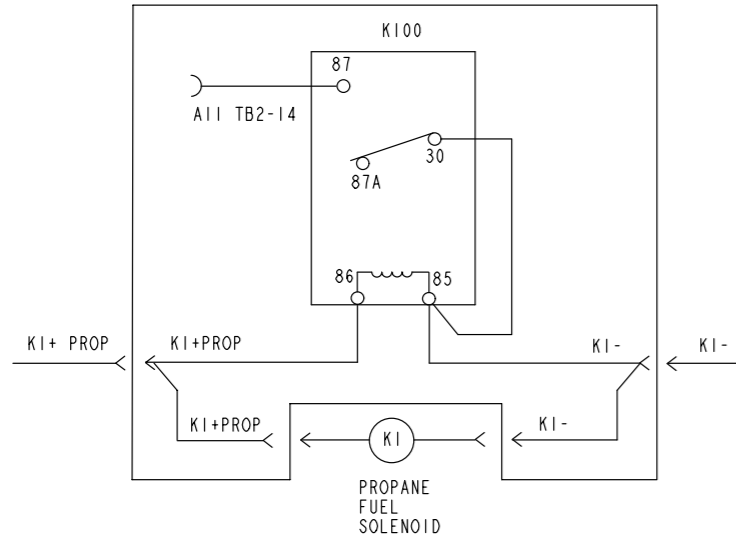

REF: HARNESS 0338-4037

V6 4.2L GOVERNOR

GGFD
GGFE
SPEC B C

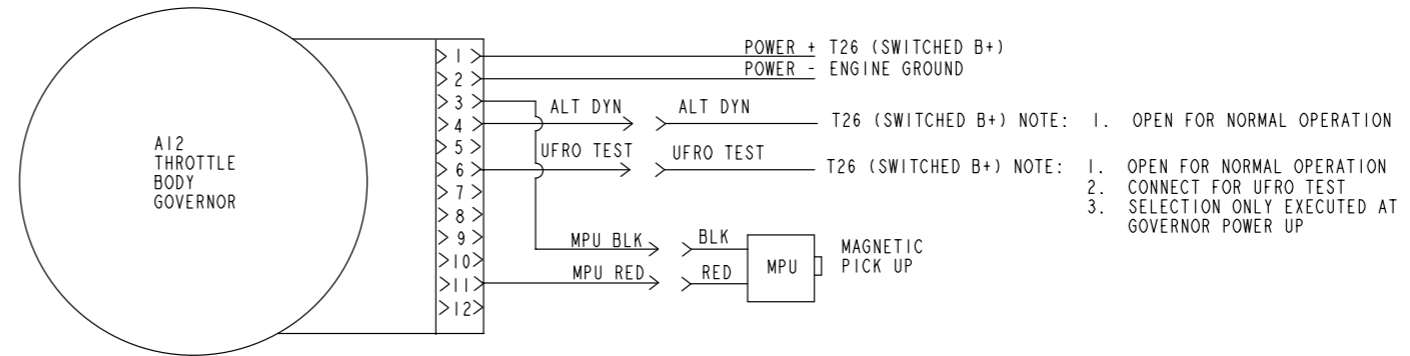

THIS IS A REPRESENTATIVE (GENERIC) SCHEMATIC/WIRING DIAGRAM. FOR TROUBLESHOOTING, REFER TO THE WIRING DIAGRAM PACKAGE THAT WAS INCLUDED WITH YOUR GENSET.

V6 4.2L AIR/FUEL CONTROLLER

GGFD
GGFE
SPEC B C

(OPTIONAL)

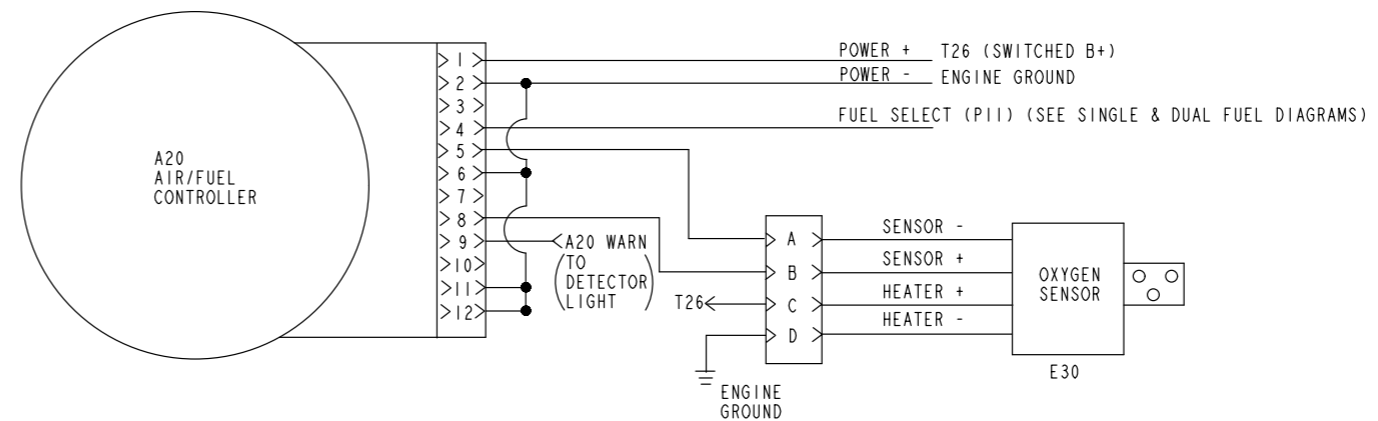

No. 612-6733 sh 8 of 9
Rev. P
Modified 7-03

TB1-10 (SWITCHED B + OUTPUT) FUSED AT 20 AMPS, ENERGIZED WHEN THE START SIGNAL IS APPLIED AND DE-ENERGIZED AT SHUTDOWN (NORMAL AND FAULT)

TB1-9 (B + INPUT) BATTERY POSITIVE (+) CONNECTION

TB1-8 (START SOLENOID) FUSED AT 20 AMPS

TB1-7 (B + OUTPUT) OUTPUT TO TIME DELAY START/STOP MODULE A15 (WHEN USED), FUSED AT 15 AMPS, AVAILABLE WHEN THE STARTING BATTERIES ARE CONNECTED

TB1-6 (REMOTE START) CONNECTED TO TIME DELAY START/STOP MODULE A15 (WHEN USED), CONNECT REMOTE START CONTACT OF THE AUTOMATIC TRANSFER SWITCH TO TERMINAL TB1-5 OF MODULE A15 (WHEN USED) OR TB1-6 OF EMB

TB1-5 (GROUND)

TB1-4 (COMMON ALARM B + OUTPUT) 4 AMP RATED DEVICE MAXIMUM

TB1-3 (RUN) CONNECTED TO TIME DELAY START/STOP MODULE A15 (WHEN USED)

TB1-2 (DC DISCONNECT) CONNECTED TO TIME DELAY START/STOP MODULE A15 (WHEN USED)

THIS IS A REPRESENTATIVE (GENERIC) SCHEMATIC/WIRING DIAGRAM. FOR TROUBLESHOOTING, REFER TO THE WIRING DIAGRAM PACKAGE THAT WAS INCLUDED WITH YOUR GENSET.

TB2-1 (FAULT 2) GROUND INPUT FROM SENDER

TB2-2 (FAULT 2) GROUND OUTPUT TO LIGHT/RELAY*

TB2-3 (FAULT 1) GROUND INPUT FROM SENDER

TB2-4 (FAULT 1) GROUND OUTPUT TO LIGHT/RELAY*

TB2-5 (REMOTE RESET) MOMENTARY CONTACT TO GROUND

TB2-6 (OVERCRANK FAULT) GROUND OUTPUT TO LIGHT/RELAY*

TB2-7 (OVERSPEED FAULT) GROUND OUTPUT TO LIGHT/RELAY*

TB2-8 (HIGH ENGINE TEMPERATURE FAULT) GROUND OUTPUT TO LIGHT/RELAY*

TB2-9 (LOW OIL PRESSURE FAULT) GROUND OUTPUT TO LIGHT/RELAY*

TB2-10 (PRE-HIGH ENGINE TEMPERATURE WARNING) GROUND OUTPUT TO LIGHT/RELAY*

TB2-11 (PRE-LOW OIL PRESSURE WARNING) GROUND OUTPUT TO LIGHT/RELAY*

TB2-12 (SWITCH OFF WARNING) GROUND OUTPUT TO LIGHT/RELAY*

TB2-13 (LOW ENGINE TEMPERATURE WARNING) GROUND OUTPUT TO LIGHT/RELAY*

TB2-14 (LOW FUEL WARNING) GROUND INPUT FROM SENDER

TB2-15 (LOW FUEL WARNING) GROUND OUTPUT TO LIGHT/RELAY*

TB2-16 (EMERGENCY SHUT DOWN) MOMENTARY CONTACT TO GROUND

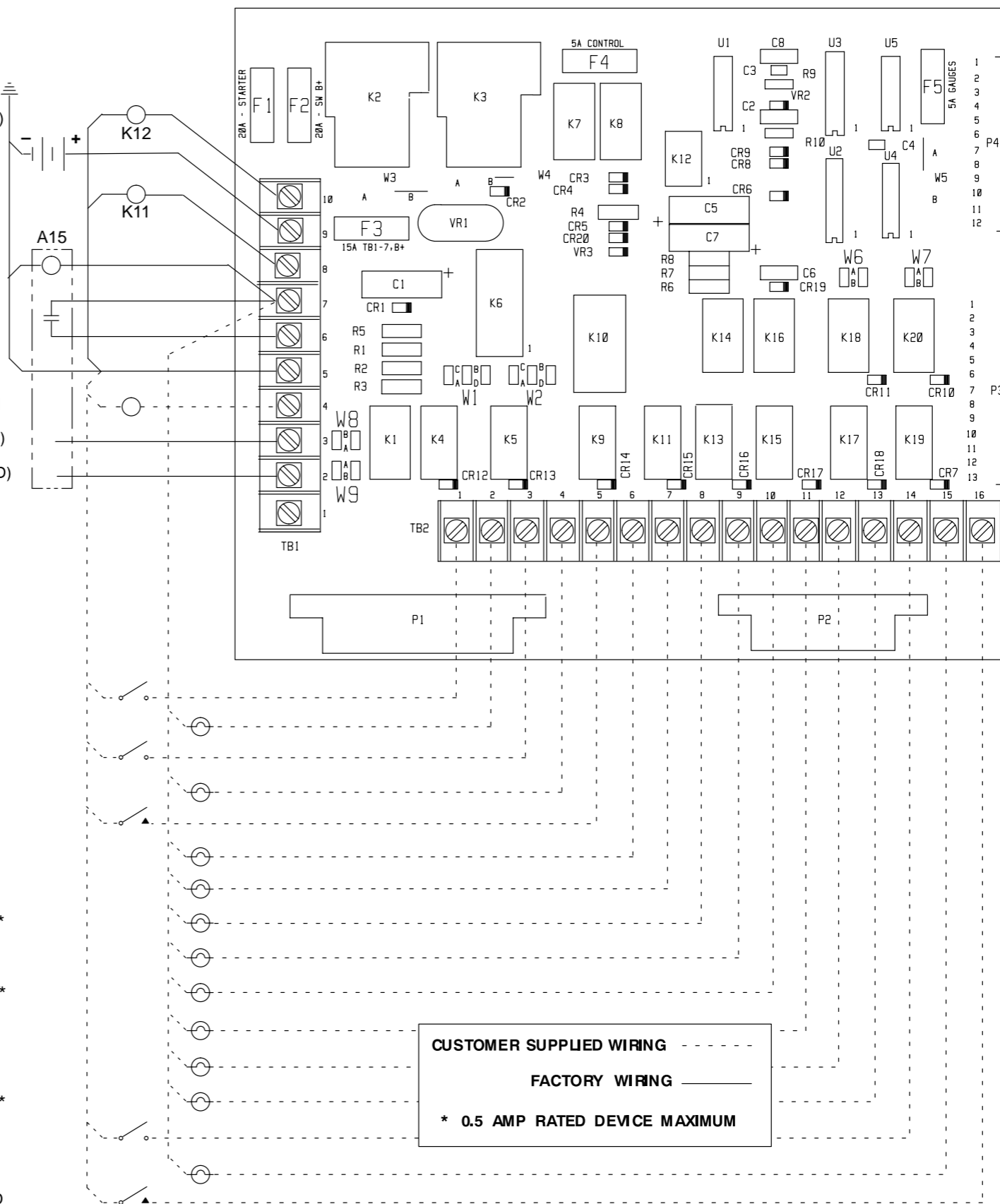

CUSTOMER SUPPLIED WIRING - - - - -

FACTORY WIRING ————

*** 0.5 AMP RATED DEVICE MAXIMUM**

TYPICAL CUSTOMER CONNECTIONS AT THE ENGINE CONTROL MONITOR (ECM)

THIS IS A REPRESENTATIVE (GENERIC) SCHEMATIC/WIRING DIAGRAM. FOR TROUBLESHOOTING, REFER TO THE WIRING DIAGRAM PACKAGE THAT WAS INCLUDED WITH YOUR GENSET.

T26	SWITCHED B+ TERMINALS LOW COOLANT LEVEL SENSOR
PREHET	PRE HIGH ENGINE TEMP
P8	IGNITION HARNESS CONNECTOR
P1	MAG PICKUP
K5	OVERSPEED SENSE RELAY
K4	STARTER PILOT RELAY
K1-SV	FUEL SOLENOID START VALVE
K1	FUEL SOLENOID
HET	HIGH ENGINE TEMPERATURE
G1	ENGINE ALTERNATOR
E2	SENDER-WATER TEMP
E1	SENDER-OIL PRESSURE
CR1	DIODE
BAT	BATTERY
B1	STARTER & SOLENOID
A12	GOVERNOR
A11	ENGINE MONITOR BOARD

LEAD TABULATION									
FROM	TO								
J1-1	TB21-21								
J1-2	TB21-32								
J1-6	GND CONT								
J1-7	J3-6								
J1-8	J3-7								
J2-1	J3-1								
J2-2	J3-4								
J2-3	J3-2								
J2-4	S7 PRE HET								
J2-5	J3-5								
J2-5	S7 HET								
E2	J3-9								
J-E1-4	J3-10								
A11TB1-7	J3-11								
B1 BAT	G1 B+								
B1 BAT	K4-87								
A11TB1-9	K4-87								
A11TB1-8	K4-86								
K1-SV POS	K4-85								
B1 SW	K4-30								
S7 SENSOR	S7 SIG								
K1-SV NEG	K4-85								
K5-85	GND-ENG								
J3-12		GND-ENG							
GND CONT			GND-ENG						
A12 BLK				GND-ENG					
G1 GND					GND-ENG				
S7 -						GND-ENG			
J-E1-2							GND-ENG		
P8-G								GND-ENG	
K1 -									GND-ENG
K1 -									
K1 +	T26								
A11TB1-10	T26								
J-E1-1	T26								
A12 RED	T26								
P8-J	T26								
P8-E	T26								
CR1-A	T26								
CR1-C	S7 +								
P8-D	G1 D+								
J2-6	K5-87								
J1-5	P8-C								
P8-K	K5-86								
P8-K	P11								

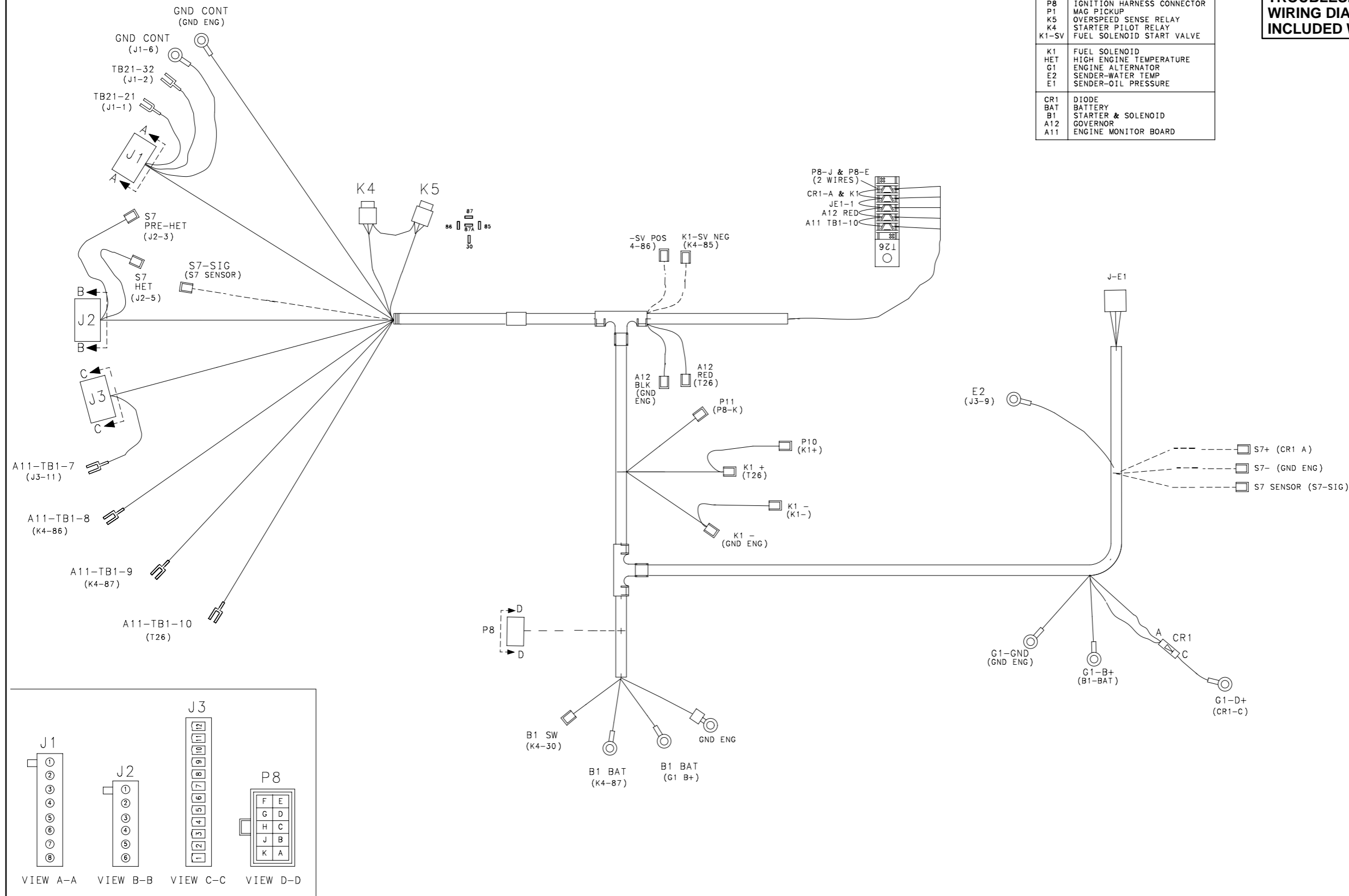

No. 338-3925 sh 2 of 2
Rev. D
Modified 8-02



THIS IS A REPRESENTATIVE (GENERIC) SCHEMATIC/WIRING DIAGRAM FOR TROUBLESHOOTING, REFER TO THE WIRING DIAGRAM PACKAGE THAT WAS INCLUDED WITH YOUR GENSET.

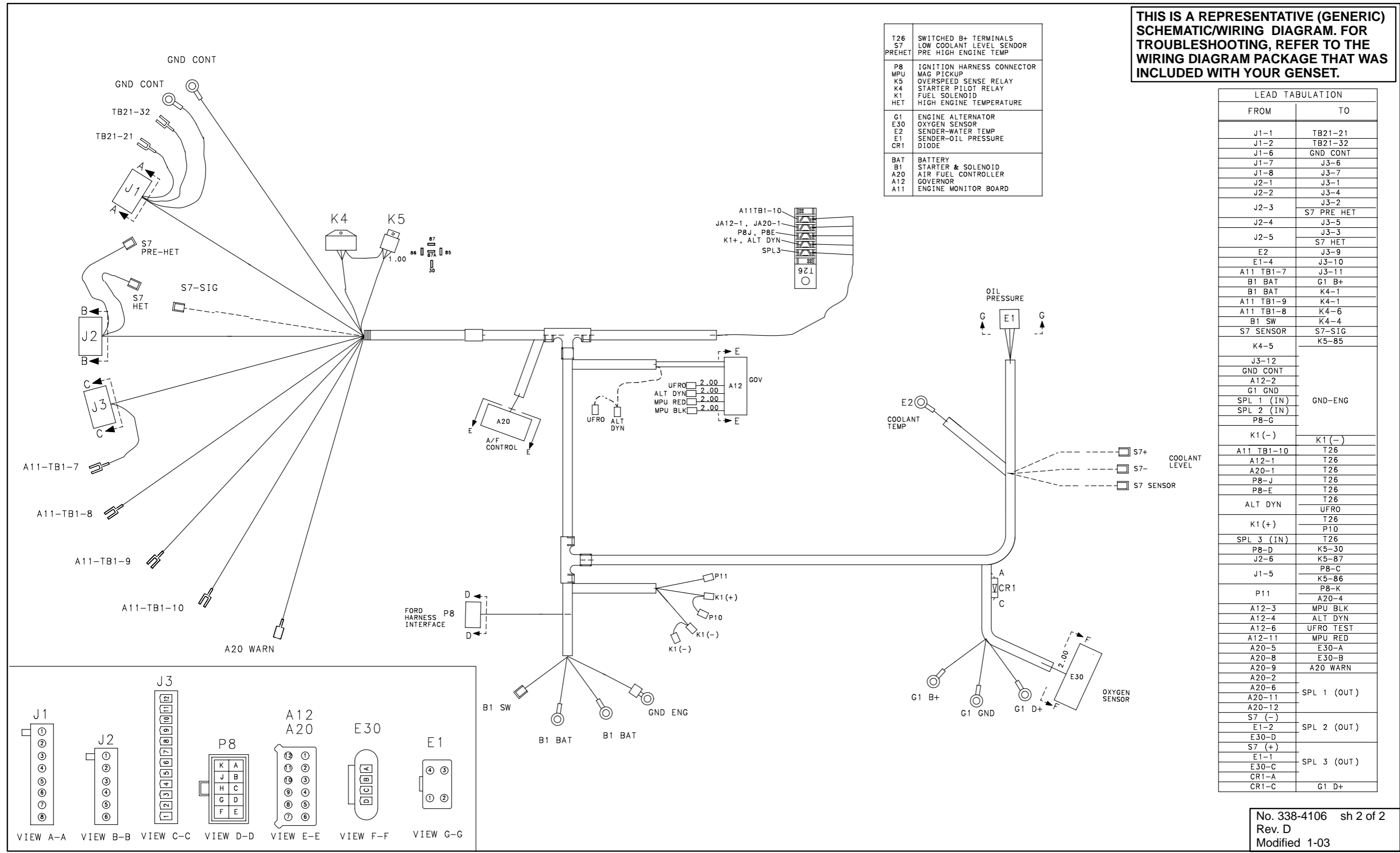

T26	SWITCHED B+ TERMINALS
S7	LOW COOLANT LEVEL SENSOR
PREHET	PRE HIGH ENGINE TEMP
P8	IGNITION HARNESS CONNECTOR
MPU	MAG PICKUP
K4	OVERSPEED SENSE RELAY
K5	STARTER PILOT RELAY
K1	FUEL SOLENOID
HET	HIGH ENGINE TEMPERATURE
G1	ENGINE ALTERNATOR
E30	OXYGEN SENSOR
E2	SENDER-WATER TEMP
E1	SENDER-OIL PRESSURE
CR1	DIODE
BAT	BATTERY
B1	STARTER & SOLENOID
A20	AIR FUEL CONTROLLER
A12	GOVERNOR
A11	ENGINE MONITOR BOARD

LEAD TABULATION	
FROM	TO
J1-1	TB21-21
J1-2	TB21-32
J1-6	GND CONT
J1-7	J3-6
J1-8	J3-7
J2-1	J3-1
J2-2	J3-4
J2-3	J3-2
J2-4	S7 PRE HET
J2-5	J3-5
	J3-3
	S7 HET
E2	J3-9
E1-4	J3-10
A11 TB1-7	J3-11
B1 BAT	G1 B+
B1 BAT	K4-1
A11 TB1-9	K4-1
A11 TB1-8	K4-6
B1 SW	K4-4
S7 SENSOR	S7-SIG
K4-5	K5-85
J3-12	
GND CONT	
A12-2	
G1 GND	GND-ENG
SPL 1 (IN)	
SPL 2 (IN)	
P8-G	
K1 (-)	K1 (-)
A11 TB1-10	T26
A12-1	T26
A20-1	T26
P8-J	T26
P8-E	T26
ALT DYN	UFRO
K1 (+)	T26
	P10
SPL 3 (IN)	T26
P8-D	K5-30
J2-6	K5-87
P8-C	P8-C
J1-5	K5-86
P11	P8-K
	A20-4
A12-3	MPU BLK
A12-4	ALT DYN
A12-6	UFRO TEST
A12-11	MPU RED
A20-5	E30-A
A20-8	E30-B
A20-9	A20 WARN
A20-2	
A20-6	SPL 1 (OUT)
A20-11	
A20-12	
S7 (-)	SPL 2 (OUT)
E1-2	
E30-D	
S7 (+)	
E1-1	SPL 3 (OUT)
E30-C	
CR1-A	
CR1-C	G1 D+

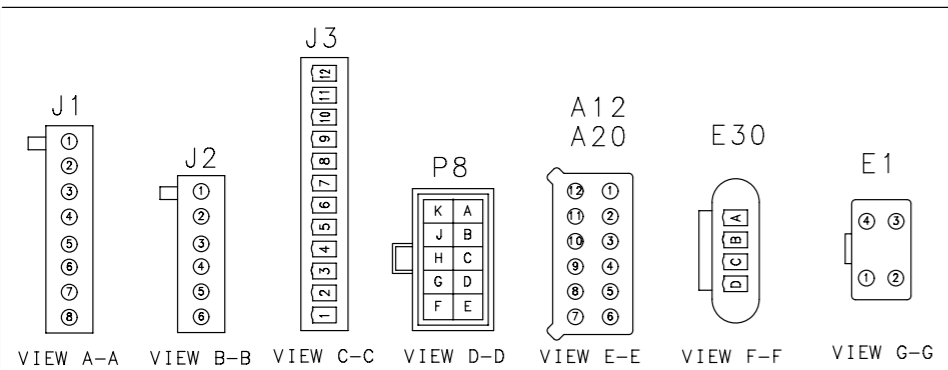

V6 ENGINE HARNESS (SPEC B)

No. 338-4106 sh 2 of 2
Rev. D
Modified 1-03

THIS IS A REPRESENTATIVE (GENERIC) SCHEMATIC/WIRING DIAGRAM. FOR TROUBLESHOOTING, REFER TO THE WIRING DIAGRAM PACKAGE THAT WAS INCLUDED WITH YOUR GENSET.

LEAD TABULATION	
FROM	TO
J1-1	TB21-21
J1-2	TB21-32
J1-6	GND CONT
J1-7	J3-6
J1-8	J3-7
J2-1	J3-1
J2-2	J3-4
J2-3	J3-2
J2-4	S7 PRE HET
J2-5	J3-5
J2-5	J3-3
J2-5	S7 HET
E2	J3-9
E1-4	J3-10
A11 TBI-7	J3-11
BI BAT	G1 B+
BI BAT	K4-1
A11 TBI-9	K4-1
A11 TBI-8	K4-6
BI SW	K4-4
S7 SENSOR	S7-SIG
K7-30	K7-85
K4-5	GND ENG
J3-12	GND ENG
GND CONT	GND ENG
A12-2	GND ENG
G1 GND	GND ENG
SPL 1 (IN)	GND ENG
SPL 2 (IN)	GND ENG
P8-G	GND ENG
K1(-)	K1(-)
A11 TBI-10	T26
A12-1	T26
A20-1	T26
P8-J	T26
P8-E	T26
ALT DYN	T26
K1(+)	T26
SPL 3 (IN)	T26
J2-6	P8-B
J1-5	P8-C
P8-K	K7-87
P11	K7-86
A20-4	A20-4
A12-3	MPU BLK
A12-4	ALT DYN
A12-6	UFRO TEST
A12-11	MPU RED
A20-5	E30-A
A20-8	E30-B
A20-9	A20 WARN
A20-2	SPL 1 (OUT)
A20-6	SPL 1 (OUT)
A20-11	SPL 1 (OUT)
A20-12	SPL 1 (OUT)
S7 (-)	SPL 2 (OUT)
E1-2	SPL 2 (OUT)
E30-D	SPL 3 (OUT)
S7 (+)	SPL 3 (OUT)
E1-1	SPL 3 (OUT)
E30-C	SPL 3 (OUT)
CRI-A	G1 D+
CRI-C	G1 D+

T26	SWITCHED B+ TERMINALS
S7	LOW COOLANT LEVEL SENSOR
PREHET	PRE HIGH ENGINE TEMP
P8	IGNITION HARNESS CONNECTOR
MPU	MAG PICKUP
K7	ICM FUEL SELECT RELAY
K4	STARTER PILOT RELAY
K1	FUEL SOLENOID
HET	HIGH ENGINE TEMPERATURE
G1	ENGINE ALTERNATOR
E30	OXYGEN SENSOR
E2	SENDER-WATER TEMP
E1	SENDER-OIL PRESSURE
CRI	DIODE
BAT	BATTERY
B1	STARTER & SOLENOID
A20	AIR FUEL CONTROLLER
A12	GOVERNOR
A11	ENGINE MONITOR BOARD

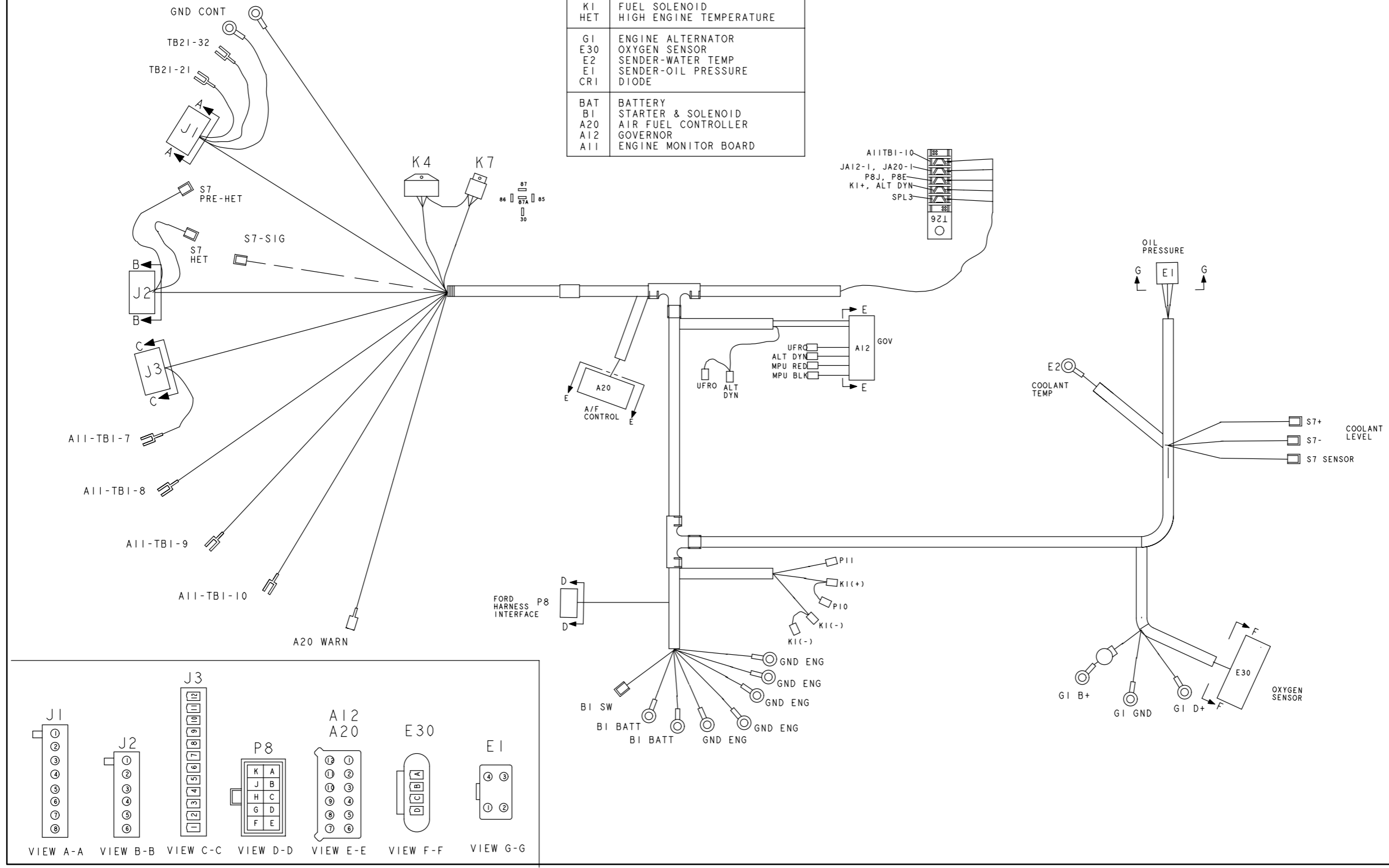

No. 338-4286 sh 2 of 2
Rev. A
Modified 10-02



THIS IS A REPRESENTATIVE (GENERIC) SCHEMATIC/WIRING DIAGRAM FOR TROUBLESHOOTING, REFER TO THE WIRING DIAGRAM PACKAGE THAT WAS INCLUDED WITH YOUR GENSET.

T26	SWITCHED B+ TERMINALS
S7	LOW COOLANT LEVEL SENDOR
PREHET	PRE HIGH ENGINE TEMP
P8	IGNITION HARNESS CONNECTOR
P1	MAG PICKUP
K5	OVERSPEED SENSE RELAY
K4	STARTER PILOT RELAY
K1-SV	FUEL SOLENOID START VALVE
K1	FUEL SOLENOID
HET	HIGH ENGINE TEMPERATURE
G1	ENGINE ALTERNATOR
E2	SENDER-WATER TEMP
E1	SENDER-OIL PRESSURE
CR1	DIODE
B1	BATTERY
A12	STARTER & SOLENOID GOVERNOR
A11	ENGINE MONITOR BOARD

LEAD TABULATION	
FROM	TO
J1-1	TB21-21
J1-2	TB21-32
J1-6	GND CONT
J1-7	J3-6
J1-8	J3-7
J2-1	J3-1
J2-2	J3-4
J2-3	J3-2
J2-4	S7 PRE HET
J2-5	J3-5
J2-5	S7 HET
E2	J3-9
J-E1-4	J3-10
A11TB1-7	J3-11
B1 BAT	G1 B+
B1 BAT	G1 B+
A11TB1-9	K4-87
A11TB1-8	K4-86
K1-SV POS	K4-86
B1 SW	K4-30
S7 SENSOR	S7 SIG
K1-SV NEG	K4-85
K5-85	K4-85
J3-12	GND-ENG
GND CONT	
A12 BLK	
G1 GND	
S7 -	
J-E1-2	
P8-D	
P8-G	
K1 -	
K1 -	
K1 +	T26
A11TB1-10	T26
J-E1-1	T26
P8-B	T26
P8-H	T26
P8-J	T26
P8-E	T26
CR1-A	T26
CR1-C	S7 +
P8-C	G1 D+
J2-6	K5-30
J2-6	K5-87
J1-5	P8-A
J1-5	K5-86
P8-K	P11
A12 RED	T26

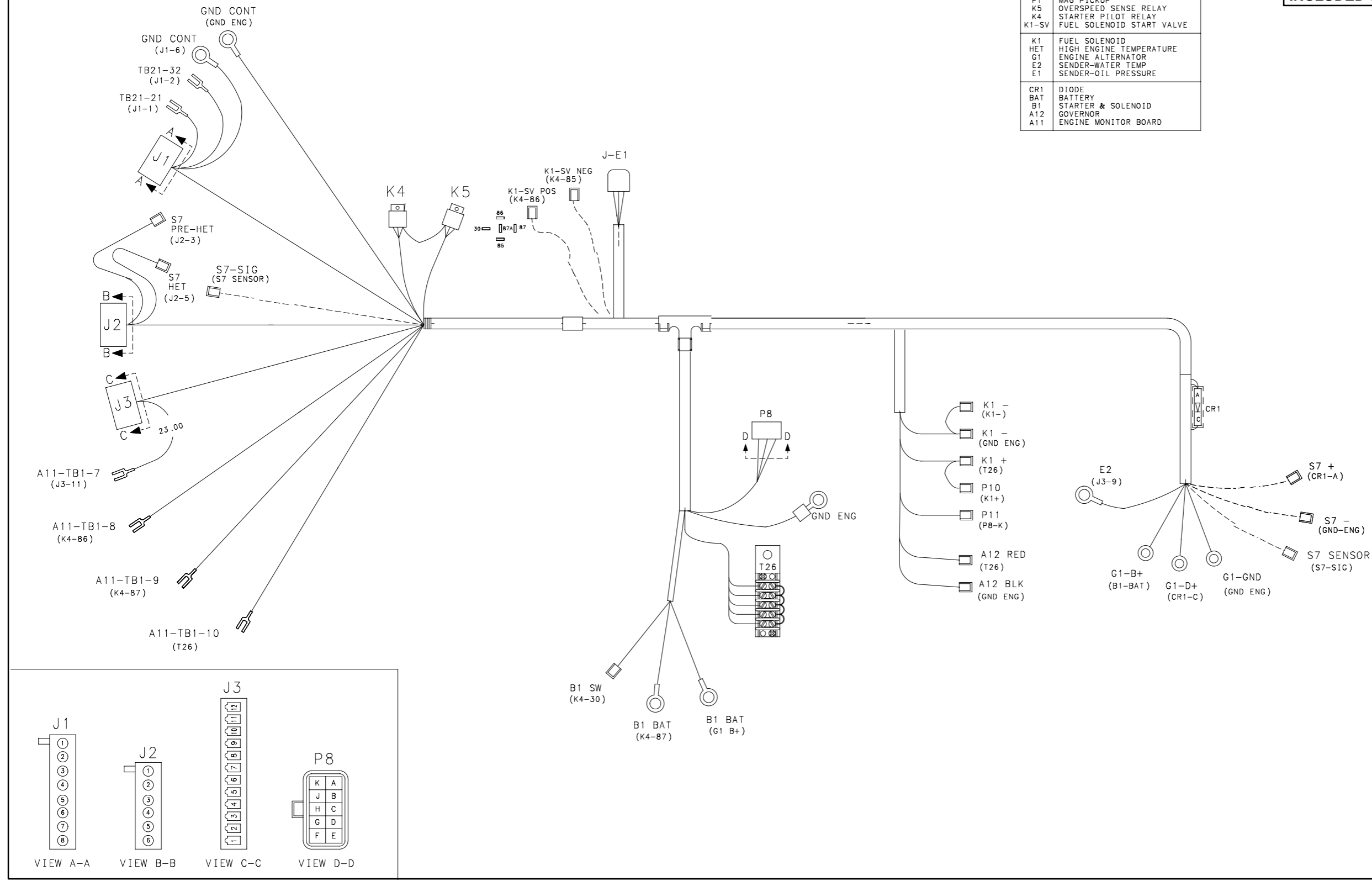

V10 NATURALLY ASPIRATED ENGINE HARNESS (TQ-125 GOV) (SPEC A)

No. 338-3921 sh 2 of 2
Rev. E
Modified 8-02

THIS IS A REPRESENTATIVE (GENERIC) SCHEMATIC/WIRING DIAGRAM. FOR TROUBLESHOOTING, REFER TO THE WIRING DIAGRAM PACKAGE THAT WAS INCLUDED WITH YOUR GENSET.

KEY	
A11	ENGINE MONITOR BOARD
A12	GOVERNOR
A20	AIR/FUEL CONTROLLER
B1	STARTER AND SOLENOID
BATT	BATTERY
CRI	DIODE
E1	OIL PRESSURE SENDER
E2	WATER TEMP SENDER
E9	MAP SENSOR
E30	OXYGEN SENSOR
G1	ENGINE ALTERNATOR
K1	FUEL SOLENOID
K4	STARTER RELAY
K5	OVERSPEED SENSE RELAY
S4	LOW ENGINE TEMP
S5	PRE LOW OIL PRESSURE
S7	LOW COOLANT SENDER
SPL	WIRE SPLICE
T26	SWITCHED B+ TERMINAL

LEAD TABULATION	
FROM	TO
A20-2	SPL 2 (OUT)
A20-6	
A20-11	
A20-12	SPL 3 (OUT)
A12-2	
E30-D	SPL 4 (OUT)
K4-5	
E1-2	
S7 (-)	
K1 (-)	K1 (-)
CRI-C	G1 D+

LEAD TABULATION	
FROM	TO
J1-1	TB21-21
J1-2	TB21-32
J1-6	GND CONT
J1-7	J3-6
J1-8	J3-7
J2-1	J3-1
J2-2	J3-4
J2-3	J3-2
J2-4	S7 PRE HET
J2-5	J3-5
J2-5	J3-3
J2-5	S7 HET
E2	J3-9
E1-4	J3-10
A11 TBI-7	J3-11
B1 BATT	G1 B+
B1 BATT	K4-1
A11 TBI-9	K4-1
B1 SW	K4-4
S7 SENSOR	S7 SIG
GND CONT	J3-12
GND CONT	GND ENG
G1 GND	
P8-D	
P8-G	
SPL 2 (IN)	P10
SPL 3 (IN)	
SPL 4 (IN)	
K1 (+)	
CRI-A	T26
A11 TBI-10	S7 (+)
P8-B	T26
P8-J	T26
P8-H	T26
P8-E	T26
SPL 1 (IN)	T26
E1-1	T26
P8-C	K5-30
J2-6	K5-87
J1-5	K5-86
P8-K	P8-A
A20-4	P11
A12-3	MPU BLK
A12-11	MPU RED
A12-6	UFRO TEST
A12-4	ALT DYN
A12-5	E9-A
A12-7	E9-C
A12-8	E9-B
A20-5	E30-A
A20-8	E30-B
A20-9	A20 WARN
A20-1	SPL 1 (OUT)
A12-1	
E30-C	ALT DYN
UFRO	

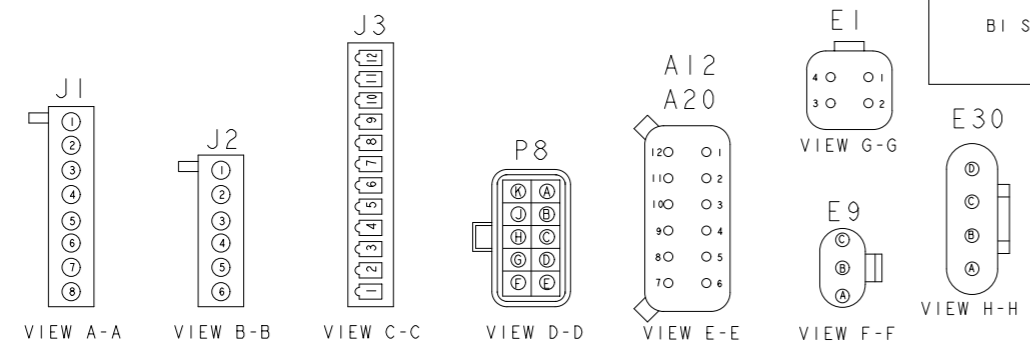
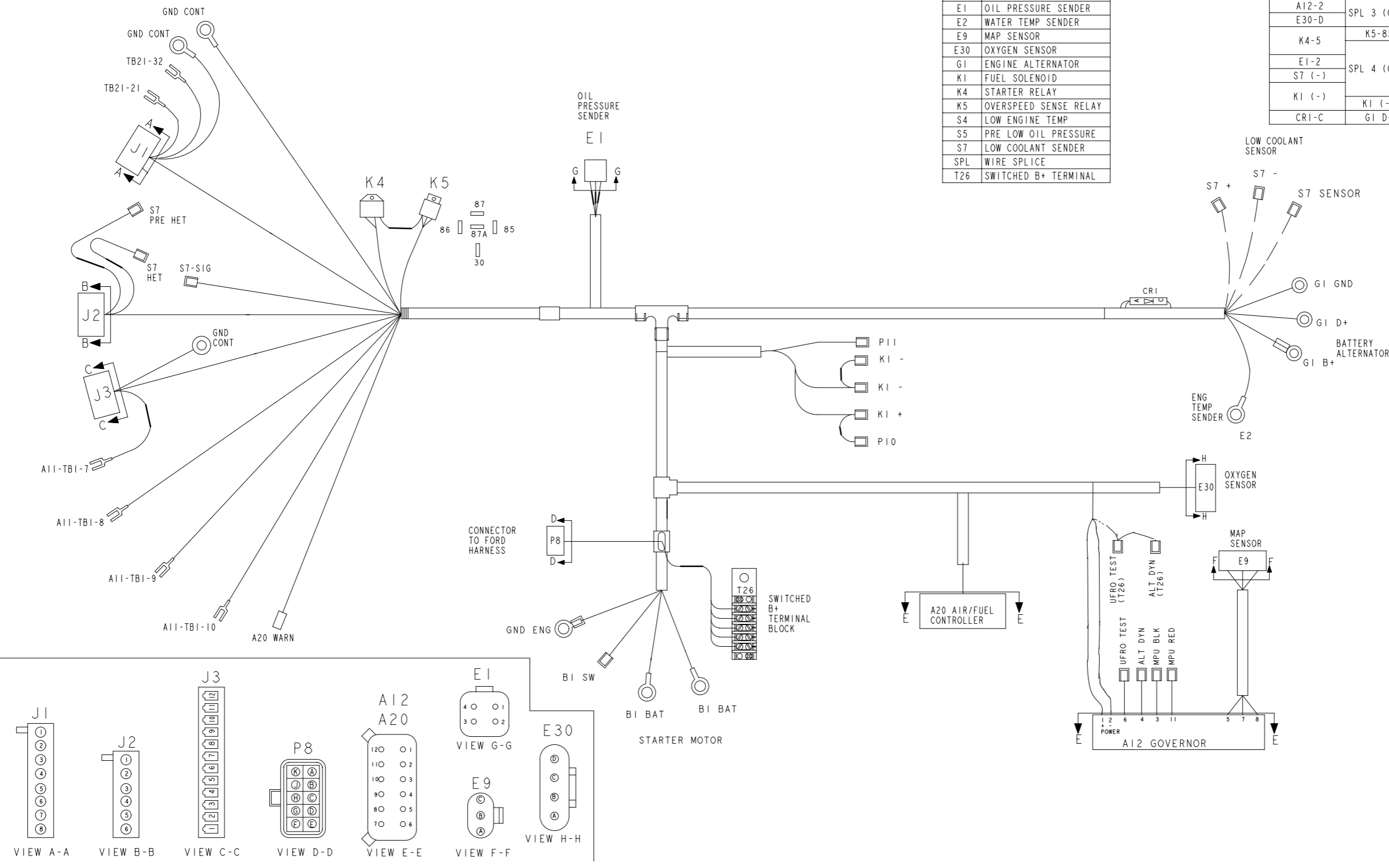

o. 8-4 09
ev.
odified 8-0



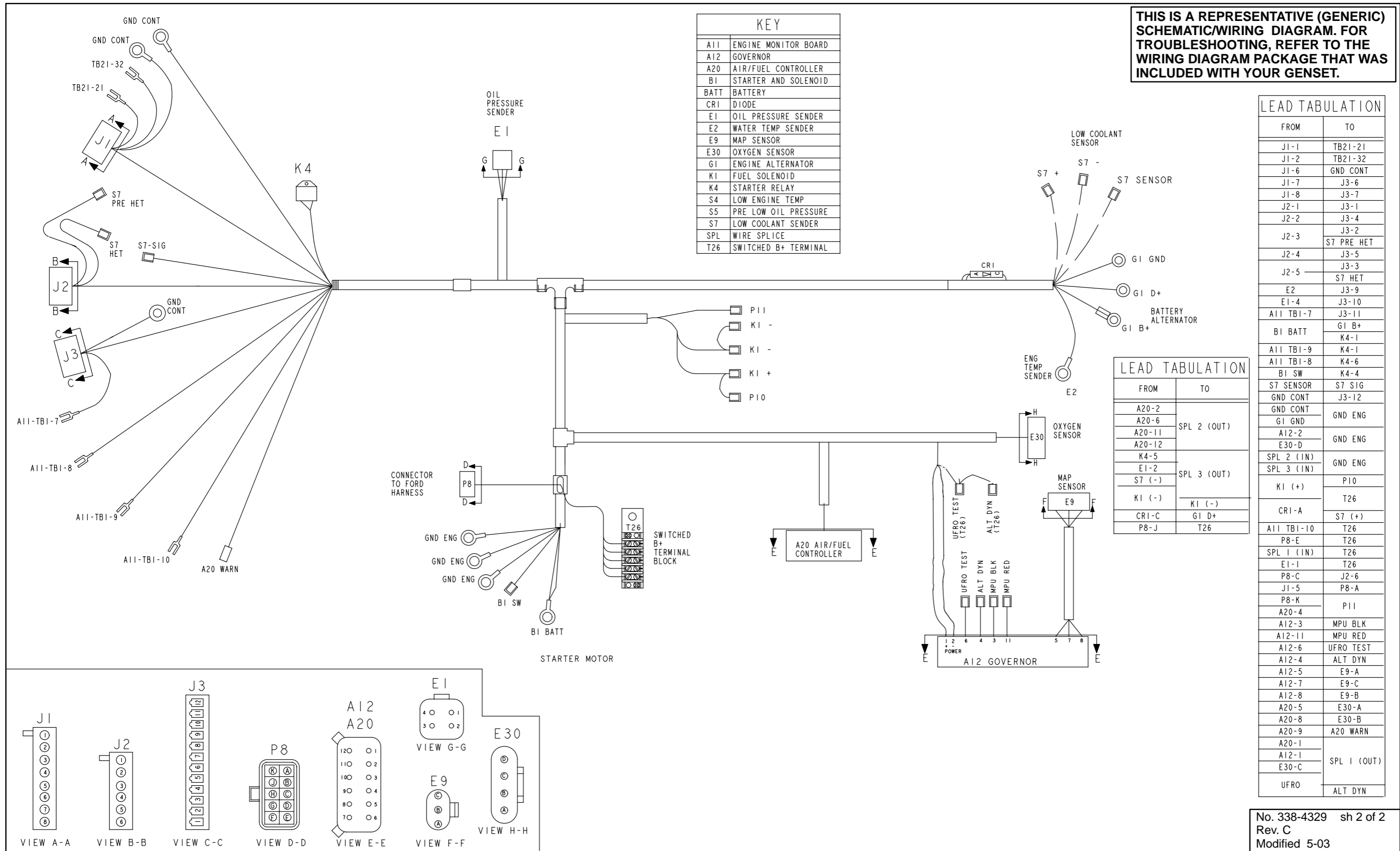

THIS IS A REPRESENTATIVE (GENERIC) SCHEMATIC/WIRING DIAGRAM FOR TROUBLESHOOTING, REFER TO THE WIRING DIAGRAM PACKAGE THAT WAS INCLUDED WITH YOUR GENSET.

V10 (TURBO/NATURALLY ASPIRATED) ENGINE HARNESS (E-CONTROL IGNITION)

Cummins Power Generation
1400 73rd Avenue N.E.
Minneapolis, MN 55432
1-800-888-6626
763-574-5000 International Use
Fax: 763-528-7229

Cummins is a registered trademark of Cummins Inc.



Redistribution or publication of this document
by any means, is strictly prohibited.