

# DYNAGEN<sup>®</sup>

**control solutions you can trust**

# ES52

*Auto Start Engine Controller*

**Installation and User Manual for the ES52 Auto Start Engine Controller.**

**Full Version**

File: MAN-0001 R3.0, ES52 User Manual.doc  
Date: December 2015

**Thank You For Purchasing This DynaGen Product**

**Please Read Manual Before Installing Unit**

## **Receipt of Shipment and Warranty Return Information**

Upon receipt of shipment, carefully remove the unit from the shipping container and thoroughly examine the unit for shipping damage. In case of damage, immediately contact the carrier and request that an inspection report be filed prior to contacting DynaGen.

All returned items are to be shipped prepaid and include a Return Material Authorization (RMA) number issued by DynaGen.

## **Limited Warranty**

For warranty information refer to the standard terms and conditions of sale at <http://www.dynagen.ca>.

## **Dynagen ES52 Support Webpage**

For up-to-date manuals and other information please see the Support section of the Dynagen website at [www.dynagen.ca/support](http://www.dynagen.ca/support).

### **ES52 Family of Products – Speed Signal Connector Change Notice**

This change will take effect in March of 2011 for all new orders. This applies only to the 2-wire speed signal connection (for mag pickup or generator output). All other connectors and controller features remain unchanged.

The existing connector and cable of Figure 2 will be replaced by the connector shown in Figure 1. The maximum voltage rating of 300V will remain unchanged. Please adjust your drawings and wire harness fabrication accordingly.

The new connector style utilizes industry standard 1/4" spade terminals. Customers are advised to select appropriate (insulated) mates to plug onto the spade terminals (female 1/4" insulated crimp connector).

Please note that the current units ship with an 8ft length of cable with a plug. This cable will become obsolete with the new connector system and thus will not be provided with shipments.

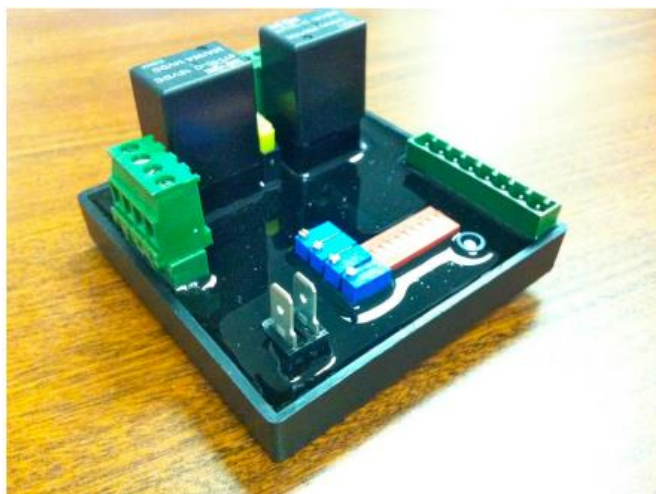

**Figure 1 New Connector 1/4" spade terminals**



**Figure 2 Old Connector Plug-in with Cable**

## ES52 Specifications

<b>Operating VDC limits:</b>	3.3VDC min - 30VDC max Provided minimum 8VDC Present at Starting.
<b>Standby current draw:</b>	12.2mA at 12VDC (12.4mA at 24VDC)
<b>Operating current draw:</b>	140mA at 12VDC (80mA at 24VDC)
<b>Reverse polarity protected:</b>	Internal protection will prevent damage to unit under a reverse polarity condition. Re-connect power leads properly, and normal operation will resume.
<b>J1113-11 Transients</b>	Pulse 1A (Supply Disconnect), Pulse 2A (Sudden Disconnect), Pulse 4 (Starter Motor Engagement), Pulse 5 (Load Dump). Details of the test parameters are available, please consult with factory.
<b>Speed sensing input accepts:</b>	Generator AC output directly Fly Wheel Alternator Engine Alternator Magnetic Pickup
<b>Speed sensing maximum rating:</b>	Withstands Line Voltage up to <b>300VAC</b>
<b>Operating temperature range:</b>	-40 °C to +70 °C
<b>Operating humidity range:</b>	0 to 95% non-condensing
<b>Fuel &amp; Crank contact output:</b>	<b>10Amps</b> maximum each continuous sourcing (+Bat) output
<b>Annunciation outputs:</b>	Sourcing (+Bat) outputs ( <b>300mA</b> maximum per output)
<b>Lamp Test terminal:</b>	Close to +Battery to test LED's
<b>Actual unit weight:</b>	0.67 lb (0.30kg)
<b>Shipping weight:</b>	1 lb (0.45kg)
<b>Unit dimensions:</b>	3.302" x 3.342" x 1.8"
<b>Shipping dimensions:</b>	4" (10.16cm) x 4" (10.16cm) x 3" (7.62cm)

## Table of Contents

<b>1. INTRODUCTION</b> .....	<b>6</b>
<b>2. WIRING INSTALLATION GUIDELINES</b> .....	<b>7</b>
2.1 WIRE SIZING.....	7
2.2 WIRING GUIDELINES .....	8
2.3 TERMINAL DESCRIPTIONS.....	9
2.4 GENERAL WIRING DIAGRAM .....	10
2.5 ADJUSTMENTS AND SETUP PROCEDURES .....	13
2.5.1 <i>Selecting the Engine Speed Range</i> .....	14
2.5.2 <i>Oil Switch Verification</i> .....	14
2.5.3 <i>Selecting a Timer Function</i> .....	15
2.5.4 <i>Adjusting Timer Duration</i> .....	16
2.5.5 <i>Crank and Crank Rest</i> .....	16
2.5.6 <i>Selecting the Maximum Number of Crank Tries</i> .....	16
2.5.7 <i>Crank Disconnect and Over-speed Pot Adjustment</i> .....	17
2.5.8 <i>Loss of Speed (...During Cranking: DIP 9)</i> .....	18
2.5.9 <i>Warm up</i> .....	18
<b>3. OPERATION</b> .....	<b>19</b>
3.1 ES52 STARTUP / SHUTDOWN BEHAVIOR.....	19
3.2 FRONT PANEL LED INDICATIONS.....	19
<b>4. TROUBLESHOOTING GUIDELINES</b> .....	<b>20</b>
<b>5. TECHNICAL NOTES ON FREQUENTLY ASKED QUESTIONS</b> .....	<b>22</b>

## 1. Introduction

The ES52 provides Automatic Start/Stop and protection control for all types of Engine-driven equipment. Simplicity of use, safety, features, versatility and over-all quality are paramount, providing the most cost effective and reliable solution available. Ours came to be one of the smallest controllers available, with the best value per dollar-cost, backed by an **Industry Leading 5 Year Warranty**.

The ES52 maintains backward compatibility to the extent that it can replace similar products without substantial rewiring. Functionally, however, it is loaded with unique features:

- "No speed signal" detection: Should the frequency of the speed sensing signal go to Zero while the engine is running, or fail to appear during cranking, a No Speed Failure is asserted and specifically indicated. **NOTE**: Speed signal detection during cranking can be disabled via an onboard Dip Switch. In some cases when using generator mains as speed signal source it is required to disable this shutdown (when residual is very low).
- Differential speed sensing inputs (for twisted-pair connection): Very effective interference prevention by means of noise cancellation.
- Excellent EMI handling: Software detection of, and recovery from, noise corruption.
- Replaceable Relays: Replaceable relays provided within on board sockets. Relays Rated 20Amps at 30VDC.
- Replaceable Fuse: On board replaceable 20Amp fuse, mini-fuse (standard automotive type).
- Reverse Polarity Protection: No requirement for series diode on supply.
- 3.3VDC to 30VDC, -40°C to +85°C Operation: Works anywhere, anytime.
- Zero Speed Restart<sup>TM</sup>: Prevents starter pinion wear by ensuring that no engagement of the starter is possible unless the speed is Zero.
- Oil Bypass<sup>TM</sup>: Waits 15 Seconds from start for 1-3 crank tries, and 20 Seconds for more than 3 crank tries, before enabling Low Oil pressure monitoring. This requires no user setting.
- Four Timer Functions: Glow Plug, *Smart Choke*<sup>TM</sup>, Air-Gate and Slow.
- Rest Time Indication: Provides feedback between crank attempts.
- Warm Up: Turns an output on which can control a load device. Warm Up timer output is provided on all ES52 units via Terminal 19. Warm Up timer is fixed at 2 Minutes.
- Small Size: 3.302" x 3.342" x 1.842" 0.67lbs.

## 2. Wiring Installation Guidelines

**Danger:** The controller does not generate a warning prior to *Automatic* Engine start. Do not work on the Engine while power is applied to the unit. It is highly recommended that warning signs be placed on Engine equipment indicating the above.

Following these instructions will help avoid common installation problems during wiring and setup.

- Battery must be disconnected before any wiring connections are made.
- Wire length from the engine to the controller should not exceed 6 meters (20 feet).

### 2.1 Wire Sizing

Wiring size and type should be as specified below. **Use stranded wire**, since solid wire has a tendency to crack, break and loosen over time.

Terminal	Wire Size	Current max.	Function
CON 1	18	100mA	Speed signal connection via on board connector
1	18	100mA	LED Test Switch
2	18	7mA	Oil Pressure Switch
3	18	7mA	High Temperature Switch
4	18	7mA	Auxiliary Input Switch
5	14	10 A	Starter Solenoid/Pilot Relay
6	12	20 A	Battery negative (-)
7	12	20 A	Auto Switch
8	12	20 A	RSC1 (remote start contact connection)
9	12	20 A	RSC2 (remote start contact connection)
10	12	20 A	Start/Stop Connection
11	14	10 A	Fuel Solenoid/Pilot Relay
12	18	300mA	Timer Output
13 to 18	18	300mA	Annunciation Outputs
19	18	300mA	Warmup Output
20	18	300mA	<u>Annunciator Common Ground Only</u> <b>(DO NOT use this as main ground connection)</b>

## 2.2 Wiring Guidelines

1. **WARNING: DO NOT** apply external voltage to annunciator outputs (terminals 13 to 18). This will damage the ES52. If this may occur in your application, place a diode in series with each affected annunciator output.
2. **DO NOT** use wire smaller than **18 AWG**.
3. The connections supplying DC power to the ES52 panel should preferably run directly from the battery posts with no splices or other connections except a 25A fuse connecting the positive line directly to the +Battery terminal. Avoid, as much as possible, using chassis (aluminum or iron engine parts) as return conductor for battery negative voltage; copper wiring is recommended. Failure to follow the above may result in erratic operation, due to large voltage drops across wiring connections.
4. **DO NOT** short **Crank** output or **Fuel** outputs to ground, as this will cause on board **20Amp** fuse to blow and may result in damage to the ES52's onboard relays.
5. When replacing fuse, removable terminals and relays, only use factory recommended parts.
6. **DO NOT** use **AC** coil slave relays from controller outputs. Use intermediate relays of suitable size and coil rating.  
**NOTE: All ES52 engine controllers are shipped standard with 12VDC coil relays for +12 VDC systems. If the engine controller is used in a +24 VDC system, the onboard relays MUST be replaced with 24VDC coil relays.**
7. **DO NOT** exceed the maximum rated **current** and **voltage** on each of the controller outputs. **Do not** exceed **10 Amps** for the **Fuel** output , **10 Amps** for the **Crank** output, and **300mA** for the **Annunciation** and **Timer** outputs.
8. The **Annunciation** and **Timer** outputs are internally protected against overload and short circuit (fault) **NOTE:** When a fault appears on one of the annunciation outputs, only that specific output becomes un-operable, all other annunciation outputs and the entire front panel LED's continue to operate. When the fault is removed and the unit is restarted, the output resumes proper operation.
9. Two wires must be connected for the speed signal
10. Diodes are provided across **Fuel**, **Crank**, and **Annunciation** outputs, to protect the outputs from inductive kick-back. Diodes should be placed across slave relay contacts when used to actuate any inductive loads, such as solenoids, to protect the contacts from damage caused by arcing. In addition to prolonging the useful life of the relays, placing such diodes will help reduce generated electrical noise.
11. To verify the operation of engine controller outputs, measure voltage (i.e. meter in volts) when outputs should be **ON**.

## 2.3 Terminal Descriptions

Term #	Description
CON1 (Speed)	<p>Speed signal input for crank disconnect, engine run, and over-speed sensing. Generator output, magnetic pickup (MPU) sensor, or alternator output can be used.</p> <ul style="list-style-type: none"> <li>- Use at least twisted pair wiring for this connection.</li> <li>- Polarity does not matter.</li> <li>- Use two female 0.250" inch insulated female quick connects for the connection.</li> </ul> <p>For MPU Sensor:</p> <ul style="list-style-type: none"> <li>- One side of the MPU must both be grounded and connected to the controller otherwise erratic behavior can result.</li> <li>- Use a shielded MPU with a shielded cable grounded at one end only for best reliability.</li> </ul>
1	<b>Lamp test.</b> Connecting +12/24 VDC to lamp test activates all of the front panel LED's. <b>NOTE: Annunciation outputs DO NOT activate under led test.</b>
2	<b>Oil pressure input.</b> For proper operation, oil input must be connected to ground or +12/24 VDC via an oil switch. This switch <b>must</b> be the <b>N.O.</b> type, close on failure (low pressure). When active shuts down the engine.
3	<b>Temperature switch.</b> For proper operation, temperature input must be connected to ground or +12/24 VDC via a temperature switch. This switch <b>must</b> be the <b>N.O.</b> type, close on failure (high temperature). When active shuts down the engine.
4	<b>The Auxiliary input.</b> For proper operation, Aux. Input must be connected to ground or +12/24 VDC via a sensor switch. This switch <b>must</b> be the <b>N.O.</b> type, close on failure. When active shuts down the engine.
5	<b>Crank output</b> provides <b>10Amps</b> maximum. Crank output closes to +12/24 VDC during cranking, and opens when the engine has started, or during crank rest.
6	<b>Battery ground</b> connection for the controller module. A good ground connection, <b>directly from the battery</b> , is required for proper operation.
7	<b>Auto.</b> When +12/24 VDC is applied; the controller is in the standby mode waiting for a Start/Stop signal (+12/24 VDC applied to Start/Stop).
8 - 9	<p><b>Remote Start Contacts</b></p> <p>RSC1 is tied internally to AUTO (terminal 7) and RSC2 is tied internally to Start/Stop (terminal 10) so when RSC1 and RSC2 are shorted they bring the battery positive that is at the Auto terminal to the Start/Stop terminal which causes the controller start the engine (see Start/Stop below) and provide power to the crank and fuel outputs.</p> <p>This means the current for <b>Crank output</b> and <b>Fuel output</b> will pass through the remote start contacts. The wiring and the remote device/switch must be rated for this current draw. If this is a problem an external relay can be used. See the tech note at the end of this manual.</p>
10	<b>Start/Stop.</b> When +12/24 VDC is applied, the controller is powered and proceeds to start the engine. The power for the <b>crank output</b> and <b>fuel output</b> is obtained from this terminal. If the 20A fuse is blown the ES52 will not start.

11	<b>Fuel output</b> provides <b>10Amps</b> maximum. Fuel output closes to +12/24 VDC when start signal is actuated, and opens when either an Engine failure is detected or when stop signal is applied.
12	<b>Timer output.</b> This output has one of four possible functions (Glow Plug, <i>Smart Choke™</i> , Air-Gate or Slow). This output closes to +12/24 VDC when activated.
13	<b>Low Oil pressure output.</b> Oil output closes to +12/24 VDC when the engine shuts down due to a Low Oil pressure condition. Flashing Low Oil output indicates an Auxiliary Input failure.
14	<b>High Temperature output.</b> Temperature output closes to +12/24 VDC when the engine shuts down due to a high temp condition.
15	<b>Over-crank output.</b> Over-crank output closes to +12/24 VDC when the engine shuts down due to an Over-crank failure.
16	<b>Over-speed output.</b> Over-speed output closes to +12/24 VDC on an Over-speed failure and is open otherwise. Flashing output indicates Loss of Speed Signal.
17	<b>Engine running output.</b> Engine Running output closes to +12/24 VDC when the engine speed is greater than the crank disconnect setting, and opens when the engine stops. Flashing output indicates Crank Rest period.
18	<b>Engine failure output.</b> Engine failure output activates on any failure (closes to +12/24 VDC when activated).
19	<b>Warmup output.</b> Output turns on after the controller has been running for <b>2 minutes and 10 seconds</b> . Output turns on immediately if battery voltage is applied to Start/Stop (terminal 10) and the speed is greater than the crank disconnect pot setting when the controller is not cranking.
<p><u>Pins 12 to 19 Note</u>  The maximum rating of each output depends on how many outputs are on simultaneously on pins 10 to 19. Do not exceed these values:  1 on = 300 mA, 2 on = 230 mA, 3 on = 160 mA, 4 on = 123 mA, 5 on = 91 mA, 6 on = 80 mA, 7 on = 66 mA, 8 on = 52mA.  Good practice is to use 50% of the maximum rating.</p>	
20	<b><u>Common ground</u></b> - <u>For annunciation outputs only. DO NOT USE AS MAIN GROUND TO CONTROLLER UNIT.</u>

## 2.4 General Wiring Diagram

See next page for the wiring diagram and dimensions.

### **ATTENTION**

All ES52 Controllers come with 12VDC Relays for 12V systems.  
For 24V systems replace with 24VDC Relays.

#### ES52 Variant Note:

A diode across Auto and Start/Stop terminals is required on versions of the ES52 with the Cool-Down feature (ES52 EI, FE, and LT variants). See the tech notes section at the end of this manual for further information. The standard ES52 version does not require this.

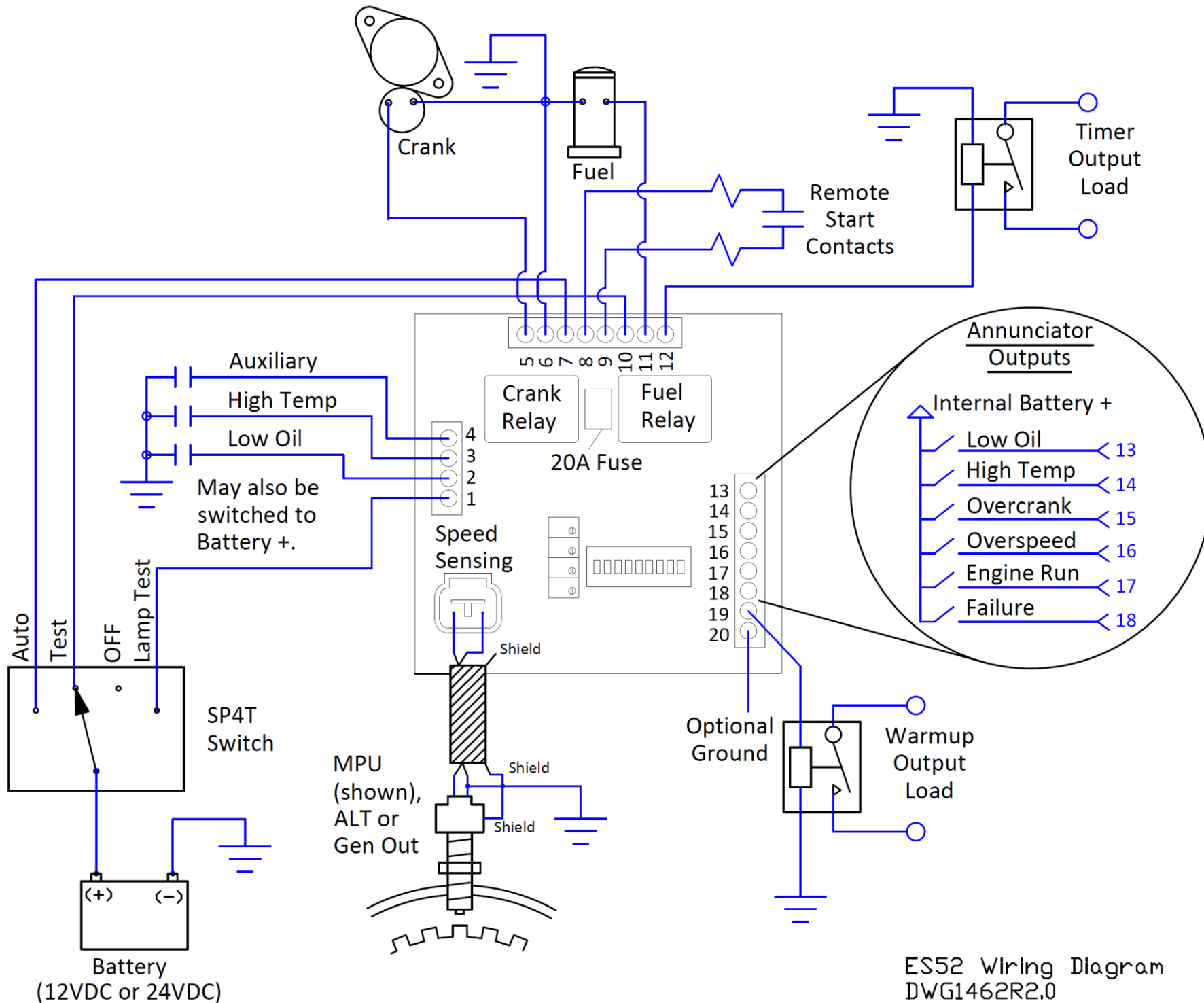

ES52 Wiring Diagram  
DWG1462R2.0

REVISIONS				
ZONE	REV	DESCRIPTION	DATE	APPROVED
	2	GENERAL REVISION	24 OCT 08	

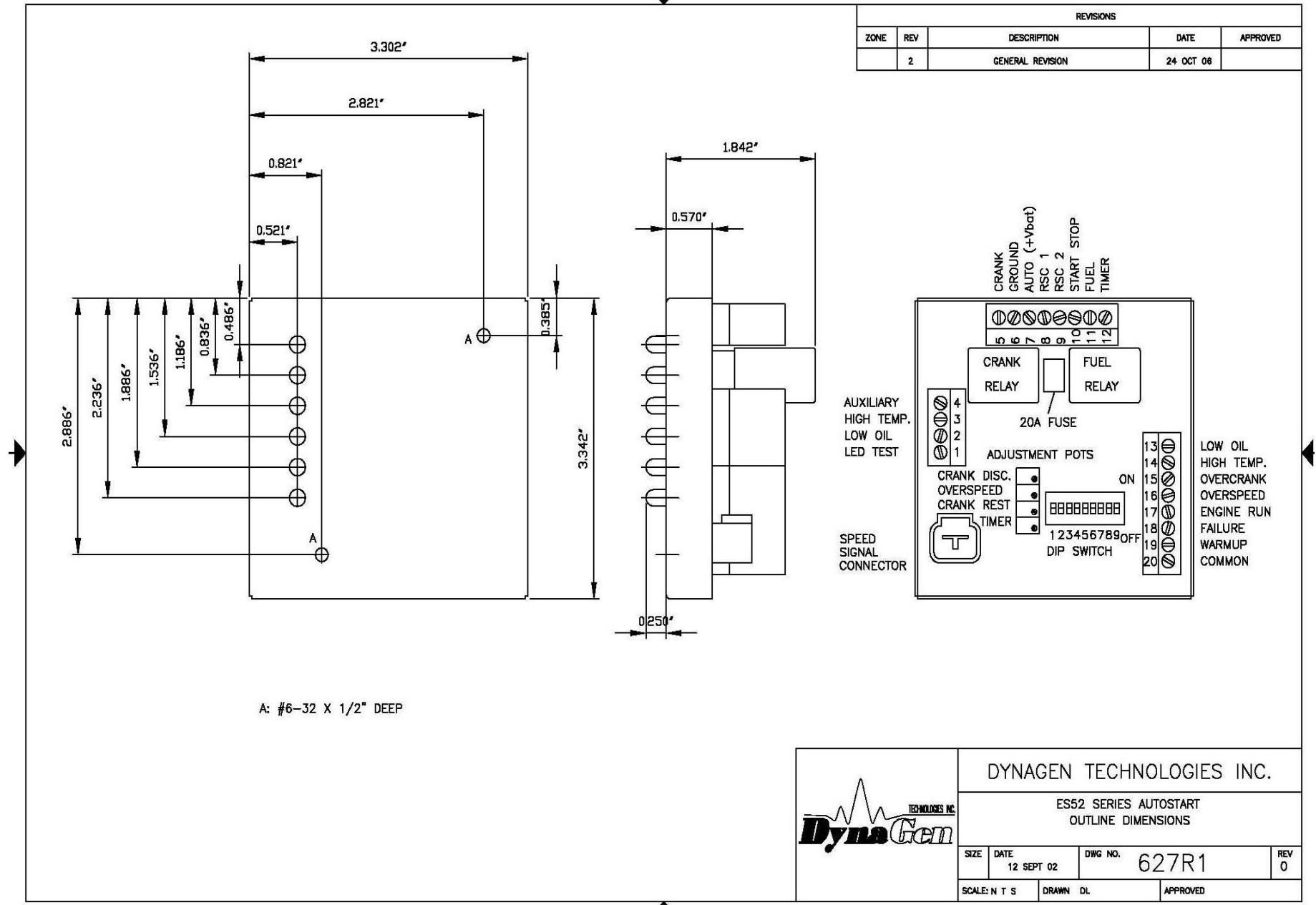

A: #6-32 X 1/2" DEEP

	DYNAGEN TECHNOLOGIES INC.		
	ES52 SERIES AUTOSTART OUTLINE DIMENSIONS		
SIZE	DATE	DWG NO.	REV
	12 SEPT 02	627R1	0
SCALE: N T S		DRAWN: DL	APPROVED

## 2.5 Adjustments and Setup Procedures





**Warning:** The following procedures will require engine operation. Be sure to follow all safety guidelines and wiring procedures.

The rear of the ES52 controller contains **4** adjustable pots, and **9** DIP switches.

### Potentiometer (Pot) Adjustment

“Potentiometer” is abbreviated as “pot” throughout. To increase a pot’s setting, turn it clockwise. To decrease it, turn it counter-clockwise. On board Pots are 20 turns nominal, therefore turn pots fully 20 turns to ensure that you are at either the minimum or maximum setting.

Potentiometers are shown below as they appear on the rear of the ES52 series units

1. Crank Disconnect	1 
2. Over-Speed	2 
3. Crank/Rest	3 
4. Timer	4 

CRANK TRIES				SPEED SETTING				TIMER (52 Model Only)						
S1	S2	S3	#	S4	S5	Range	CRDC	OVSP	S7	S8	Setting			
on	on	on	setup	off	off	lo	12 - 140	44 - 300						
off	on	on	6	on	on	hi	60 - 4156	300 - 8492						
on	off	on	5	CRDC - Crank Disconnect (Hz)										
off	off	on	4	OVSP - Overspeed (Hz)										
on	on	off	3	S6 OIL VERIFICATION				off	off	Glow Plug				
off	on	off	2	on	Enabled									
on	off	off	1	off	Disabled									
off	off	off	-	single crank attempt - 4 to 256 sec								on	off	Airgate
<b>LOSS OF SPEED WHILE CRANKING</b>				S9	on-Enabled	off-Disabled								
							on	on	Slow					

Label on Rear of ES52 series units.

"Oil Bypass<sup>TM</sup>" period refers to the delay period (fixed at 15 seconds for 1-3 crank tries and 20 seconds for more than 3 crank tries) immediately after the Engine Running LED illuminates (Engine starts). During this period the oil input is bypassed (ignored).

### **The steps to calibrate the ES52 controller to a specific system are as follows:**

1. Select the Engine Speed Range ( DIP switches 4, 5)
2. Oil Switch Verification - oil switch enabled or disabled (DIP switch 6)
3. Select a Timer function - (DIP switches 7 & 8)
4. Adjusting Timer setting - (Only needed for Slow and Glow Plug functions)
5. Crank/rest time calibration
6. Selecting the maximum number of Crank Tries (DIP switches 1, 2 & 3)
7. Crank Disconnect / Over-speed calibration
8. Loss of Speed (During Cranking) – Enable / Disable

See the following sections for a more detailed explanation of each.

#### 2.5.1 Selecting the Engine Speed Range

Two speed ranges are provided to permit greatest accuracy when adjusting Crank Disconnect and Over-speed settings. The speed ranges are selectable from DIP switches 4 and 5.

Generator output: When using generator output (50 or 60 Hz) speed range 1 (LO) is required.

Flywheel Alternator: When using a flywheel alternator speed range 1 (LO) will be required. Refer to engine's specification for number of poles attached to flywheel. i.e. 1 pole (60Hz), 2 poles (120 Hz), & 4 poles (240 Hz).

Engine Alternator: An engine alternator would require speed range 1 (LO) or 2 (HI). Refer to engine's specification for pulley ratio and number of poles before selecting range.

Magnetic pickup: A magnetic pickup would require speed range 2(HI).

Range	SW 4	SW 5	Crank Disconnect (Hz)	Over-speed (Hz)
1(LO)	OFF	OFF	12 - 140 Hz	44 – 300 Hz
2(HI)	ON	ON	60 - 4156 Hz	300 - 8492 Hz

#### Selecting the Proper Speed Range

#### 2.5.2 Oil Switch Verification

The oil pressure switch must be the type that opens when oil pressure is normal, and closes on Low Oil pressure (failure condition or engine stopped). **DIP switch 6 must be set to the ON position if you wish to enable oil verification, and set to the OFF position if oil verification is to be disabled.** If DIP switch 6 is ON, prior to Cranking, the controller will attempt to verify that the pressure switch is connected and operating properly by checking if the circuit is closed. If the oil pressure switch does not work or the wire fails to make the connection, the engine will be prevented from starting, and the ES52 will assume a 'wait and see' mode (indicated by a steady Low Oil and flashing Engine Running LED). As soon as the oil pressure switch closes, Cranking will proceed as usual. (If the engine starts, the controller will check for a Low Oil failure condition only after the *Oil Bypass<sup>TM</sup>* period). *Notice that if this verification was not*

performed, a 'bad connection' of the oil switch might go unnoticed until such time as oil runs out, and engine damage occurs!

**Note:**

- i) Oil circuit verification is only performed in the following conditions:
  - a) On the first Cranking attempt
  - b) If the engine has been previously running, and more than 5 minutes of rest has elapsed.
- ii) If DIP switch 6 is set to the off position, the ES52 does not provide oil verification. The ES52 goes immediately into cranking; it will then check for a low oil failure condition after the oil bypass period has elapsed.

SW 6	Oil switch verification
ON	Enabled
OFF	Disabled

### 2.5.3 Selecting a Timer Function

The timer function is configurable from DIP switches 7 & 8. The output terminal associated with this timer setting is terminal #12. It has four configurable functions, of which two are adjustable:

**Glow Plug:** The Glow Plug timer is **adjustable from 0 - 32 seconds**. Glow Plug is a timing function used with Diesel engines. This output is energized on every Crank attempt for a set time *prior* to Cranking engine.

**Choke:** The choke function is used on gasoline engines having an electric choke. The choke output is energized 2½ seconds into the cranking cycle, but only on even numbered Crank attempts (Exception; single crank attempt mode allows choke). If engine speed remains above Crank Disconnect setting, Choke output is turned off; but as soon as speed falls below Crank Disconnect, it is re-applied. This ON/OFF regulation will continue, if necessary, as long as the *Oil Bypass™* period is in effect.

**Air-gate:** The air-gate output is used to control an air damper and only actuates for a fixed **10 seconds** immediately after an Over-speed Failure occurs. This feature is used for some Diesel engines that cannot be stopped quickly enough by merely shutting off the Fuel in the event of an Over-speed condition. An electrically operated air damper is installed at the air intake, which effectively 'gags' the engine to a stop. Refer to engine's manual for more information.

**Slow:** This function is **adjustable from 0 - 256 seconds** via the "Timer" pot. The "Timer" output energizes when engine speed goes above Crank Disconnect speed (engine starts), and remains so for the prescribed duration. It is called "Slow" because it would, presumably, be used to tell a

*governor* to 'go slowly'; for such applications as irrigation pumps, where running slowly for the first minute or two prevents 'water hammer'.

The timer settings are as specified in the following table.

SW 7	SW8	Timer function	Adjustable Time
OFF	OFF	Glow Plug	0 - 32 seconds
ON	OFF	Air-gate	Not Adjustable(10 sec.)
OFF	ON	Choke	Not Adjustable
ON	ON	Slow	0 - 256 seconds

#### 2.5.4 Adjusting Timer Duration

**(Glow Plug and 'Slow' only, as Air-gate and Choke do not use pot) (0 - 32 seconds For Glow Plug and 0 - 256 seconds for slow)**

For the **Glow Plug setting (DIP switches 7 & 8 off)**:

- Remove wires connected to the Timer terminal #12 and Crank terminal # 5.
- Apply power to Start/Stop terminal # 10.
- Measure the time the "Timer" LED remains ON.
- Remove power from Start/Stop terminal # 10.
- Increase or decrease pot setting as required. Resolution is **1.6 seconds/turn**.
- Return to step b.

For the **slow setting (DIP switches 7 & 8 on)**:

- Apply power to Start/Stop terminal # 10.
- Allow the engine to Crank and start, Engine Running LED turns ON.
- The "Timer" LED will illuminate, measure the time that the LED remains ON.
- Increase or decrease pot setting as required pot resolution is **12.8 seconds/turn**.
- Return to step a.

Re-connect wires to the Timer terminal #12 and Crank terminal # 5 before proceeding to Step 5.

#### 2.5.5 Crank and Crank Rest

Enter **Setup Mode** by setting DIP switches 1, 2 & 3 to the ON position. Apply power to Auto, and the over crank LED will flash. The time between flashes indicates the Crank and Crank Rest time. Adjust pot accordingly to increase or decrease Crank/Rest time.

#### 2.5.6 Selecting the Maximum Number of Crank Tries

The Crank tries are adjustable from DIP switch positions 1, 2 and 3. Select the Crank tries most appropriate for your application. **Note** that an extended Crank attempt range is available, which extends the Crank time to a time spanning from 4 to 256 seconds.

CRANK ATTEMPTS	SWITCH 1	SWITCH 2	SWITCH 3	TIME RANGE
SETUP	ON	ON	ON	4 - 36 sec
6	OFF	ON	ON	4 - 36 sec
5	ON	OFF	ON	4 - 36 sec
4	OFF	OFF	ON	4 - 36 sec
3	ON	ON	OFF	4 - 36 sec
2	OFF	ON	OFF	4 - 36 sec
1	ON	OFF	OFF	4 - 36 sec
1	OFF	OFF	OFF	4 - 256 sec

### 2.5.7 Crank Disconnect and Over-speed Pot Adjustment

The **Crank disconnect pot** turned fully counterclockwise gives a frequency of **12Hz** in low speed mode and **60Hz** in high speed mode. One turn gives about **6.4Hz** in low speed and **205Hz** in high speed. The **Over-speed pot** turned fully counterclockwise gives a frequency of **44Hz** in low speed mode and **300Hz** in high speed mode. One turn gives about **13Hz** in low speed and about **410Hz** in high speed.

It takes approximately **20 turns** to go to the minimum or maximum value. Turning the pot **counterclockwise** decreases the crank disconnect / over speed. Turning the pot **clockwise** increases the crank disconnect / over speed.

Each pot has a clutch to protect from overturning and thus requires one to two turns to overcome this clutch if the pot is at the minimum or maximum position before the value actually starts changing. **Since it is not known exactly when the clutch is overcome the set value will have an error of approximately two turns.**

To determine the proper crank disconnect and over speed the best method is to use a signal generator (also known as a function generator). If you do not have one, follow this procedure.

1. Power unit in Auto.
2. Turn the Crank Disconnect pot fully counterclockwise (20 + 2 turns).
3. Turn the Over Speed pot fully clockwise (20 + 2 turns).

#### Adjusting the Crank Disconnect Pot

4. Measure the frequency of the speed source during cranking if you do not know it.
5. Adjust the crank disconnect pot – using the Hz/turn information above – to a value above the cranking frequency. Keep in mind the two turn tolerance.
6. Run unit as required and readjust pot as required for reliable start and to prevent grinding of the starter. Limit cranking time while performing this calibration to prevent damage to the starter.

### Adjusting the Over Speed Pot

7. Run unit and adjust over speed counterclockwise until unit shuts down on over speed failure.
8. Then adjust over speed pot clockwise to the desired headroom.

### 2.5.8 Loss of Speed (...During Cranking: DIP 9)

In the event there is a loss of speed, while cranking or running, the unit will shut down, and this is indicated by a **flashing Over-speed LED**. Loss of speed is defined as no speed signal for **at least 3 seconds**. Loss of speed begins 3 seconds into the crank cycle.

The **Loss of Speed While Cranking** portion can be disabled via DIP switch # 9. When the DIP switch is in the UP or ON position, the Loss of Speed While Cranking function is enabled. When the DIP switch is in the DOWN or OFF position, the Loss of Speed While Cranking function is disabled. NOTE: The Loss of Speed feature is maintained during all running conditions.

Note: If unit is configured for Generator Output, there may not be enough residual voltage during cranking for this feature. It is recommended to disable this feature.

The following values are minimal recommended voltages for speed signal:

20 HZ - .075 V (75mV)

60 HZ - .6V (600mV)

4500 HZ - .8V (800 mV)

### 2.5.9 Warm up

A Warm up timer is provided on all ES52 series engine controllers. Terminal 19 is the Warm up timer output. This output energizes 2 minutes after the engine running LED turns on (i.e. Speed above crank disconnect setting). When a stop signal is initiated, the Warm up output turns off.

This Warm up output can be used to control a load device, which allows a generator to warm up before connecting the load.

## 3. Operation

### 3.1 ES52 Startup / Shutdown Behavior

Note: The fuel output remains on during crank rest. There is no way to disable this.

### 3.2 Front Panel LED INDICATIONS

What the LED's look like	Condition/Failure
<b>No LED's ON.</b>	"Ready" unit waiting for start signal, +12/24 VDC to Auto terminal.
	"OFF", no +12/24 VDC to Auto terminal.
<b>Low Oil, steady</b>	Low Oil Pressure Failure
<b>Low Oil, flashing</b>	Auxiliary Input Failure
<b>High Temperature, steady</b>	Over-temperature Failure
<b>Over-crank, steady</b>	Engine would not start after specified Crank tries.
<b>Over-Speed, steady</b>	Speed Signal present above Over-Speed setting
<b>Over-speed, flashing</b> <b>Was engine Cranking?</b>	No speed signal available while cranking.
<b>Was engine Running?</b>	The speed signal was zero while running for 3 seconds. The engine has stalled, or the speed signal has been lost.
<b>Engine Running, steady</b>	Engine Controller is in running mode of operation.
<b>Engine Running, flashing</b>	Crank-rest period. Cranking will resume soon.
<b>"Timer", steady</b> <b>Is Over-speed LED ON?</b> <b>Is Engine Running LED ON?</b> <b>Is the engine Cranking?</b> <b>If the engine is not cranking or running</b>	10 second Air-gate timer Slow timer feature, (pot adjustable) Choke feature Glow Plug timer feature (pot adjustable)
<b>Low Oil steady while Engine Running Flashing</b>	Oil switch is not closed (miss-wired or not Installed). <b>Engine will crank when oil switch verifies.</b>
<b>Over-speed and over crank LED's flash alternately</b>	Invalid speed range - check DIP switches 4 & 5 Crank disconnect set too high

## 4. Troubleshooting Guidelines

TROUBLE	POSSIBLE CAUSE	SUGGESTED ACTION
Overcrank LED flashing	Unit is in setup mode. All DIP switches are on.	Set the DIP switches properly.
	All DIP switches are not on.	The unit is damaged. Replace.
Unit does not operate. Battery voltage present at the Start/stop terminal.	Power leads to unit are reversed.	Confirm correct wiring for ground and +bat, and re-attempt testing.
	Bad ground connection from engine to controller unit.	Run wire directly from battery - to the ground terminal #6 on controller unit.
	The 20A fuse is blown.	Replace 20A fuse.
All annunciator outputs are on.	Voltage transient on battery (maybe load dump) or outputs.	The unit is damaged. Replace.
Engine starts and immediately goes into Over-speed shutdown	Over-speed pot setting too low	Increase Over-speed pot setting to desired value.
	Improper speed range setting	Check to ensure that controller is set to proper speed range (Dip SW 4 & 5)
Engine does not crank	Battery is low or terminals are dirty	Clean terminals and re-charge battery
	Crank circuitry wiring improperly connected	Refer to engine control wiring section and check crank connections
	Bad ground connection from engine to controller	Run wire directly from battery - to the ground terminal #6 on controller unit.
	Crank relay damaged or on board fuse is blown	Check wiring, on board 20A fuse and relay. Replace fuse, relay and re-test controller again
Engine cranks but does not start	Fueling issue	Check fuel level, add fuel if necessary. Check for air pockets and fuel lines.
	Fuel relay damaged	Check fuel relay and replace if damaged.
Engine starts but shuts down after " <i>Oil Bypass<sup>TM</sup></i> period" due to low oil/high temp/extra	Oil/temp/extra input wiring improperly connected.	Check wiring for proper connections.
Engine starts, but running LED does not illuminate.	Improper speed range setting	Check to ensure that controller is set to proper speed range (DIP switches 4,5)
	Fault (short or overload) on one of the annunciator outputs	Check for fault, once fault is corrected then operation resumes.

	Crank disconnect POT set too high	Decrease crank disconnect pot setting
Annunciation output not working	Fault (short or overload) on one of the annunciator outputs	Check for fault, once fault is corrected then annunciation operation resumes.
Timer LED and timer output does not activate	Timer pot set to zero	Increase timer pot setting, turn pot clockwise
Timer LED works O.K. but timer output does not activate	Fault (short or overload) on timer output.	Check for fault, once fault is corrected then output operation resumes.
Flashing Over-speed LED (indicates loss of speed signal)	Speed signal improperly connected, missing, or damaged.	Check speed signal wiring; replace damaged speed signal source.
	Crank output damaged, not working	Check wiring and replace controller
	Starter or starter solenoid damaged	Replace/repair damaged starter or starter solenoid.
	Engine stalled.	Check fueling.
Flashing Over-speed using Generator output during cranking.	Not enough residual voltage during cranking.	Set DIP switch # 9 to OFF
Alternating flashing of over-speed & over-crank	Crank disconnect set too high	Check crank disconnect
	Wrong speed range	Check speed range
Flashing run LED & solid oil LED	Oil switch not closed as it should be	Check oil switch wiring.
		Turn DIP switch #6 OFF to disable oil verification.
Solid oil LED immediately on start-up, without engine actually cranking or starting.	False speed signal being detected by controller. This problem can sometimes occur in installations where there is AC power from inverters near generator output lines connected to the speed signal cable.	Avoid running AC lines from inverter in same conduit as generator output lines.
		Install a small step down transformer between the speed sensing wires and the generator output.
		If the neutral from the generator output is not grounded, attach it to ground at generator.

## 5. Technical Notes On Frequently Asked Questions

### 1. 10A Diode On Auto/Off/Test Switch On All Units With Cool-Down Feature ONLY! (EI, FE, and LT variants).

This tech note does NOT apply to standard ES52 units!

When using a single switch for auto/off /test on any ES52 series controller **that has the cool-down feature**, a 10A diode must be installed between test and auto with the band pointing to the auto terminal. This diode allows power to go to the auto terminal as well as the test terminal when the switch is put in test position. It is necessary to have the auto terminal powered as well as the test terminal when the unit is used in the test/manual mode. The diode offers a one-way jumper that only lets the current go from test to auto and not from auto to test. If the controller is to be used in a two-switch configuration with one being for auto and one for test, the Auto Switch has to be ON as well as the test switch when the unit is to be used in test/manual. If only the test terminal is provided with power, the unit will not operate properly.

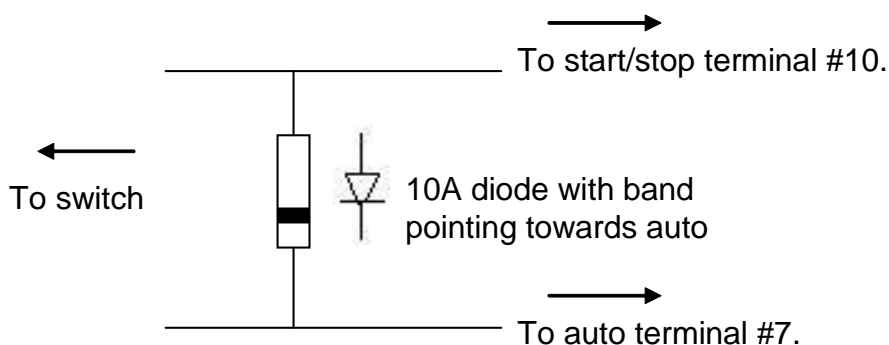

### 2. Controller Memory Clear Time

The ES52 needs 10 seconds for its memory to clear. When the power to the controller is turned off and then back on again without waiting a few seconds to clear the memory, a loss of speed will be indicated by the ES52 because the controller remains in run mode and senses that the generator has stopped. This would be indicated by a Flashing Overspeed LED. By leaving the ES52 OFF for 10 seconds before it is returned to the Auto setting the memory will be cleared and it will function as intended.

### 3. Step-Down Transformer Use On Speed Sensing Cable With Inverter Systems

In some applications engine controllers are used on generators where there is no utility connection and inverters are used to provide AC power instead of a utility. Inverters can produce harmonics that can cause small AC signals to appear on wires that are near any power lines being fed by the inverter. If the generator output wires are located close to a line being powered by an inverter, a small AC signal can appear on the generator output lines when the inverter is on. This signal can cause the engine controller to react as if the generator is running if the speed sensing wires are connected to the generator output lines. This small AC signal can cause the controller to appear to have a Low Oil Failure when the remote start contacts are closed or the controller is put in the manual/test mode. The controller may think the generator is already running and immediately check to make sure there is oil pressure. Since the engine really hasn't started yet, there is no oil pressure and the controller sees a low oil fault. This is seen as the Oil LED turning on solid even before the engine starts to engage the starter.

Without this false speed signal the controller will not look for oil pressure until the engine has started to run and the crank disengages if oil verification is disabled. Simply installing a small transformer between the generator output and the speed sensing terminals on the controller can eliminate this false speed signal. This transformer should be rated for 120 or 240 volts on the input or primary coil (depending on the generator output voltage you are using for speed sensing), and have an output voltage of around 12VAC on the secondary of the transformer. The two wires from the secondary of the transformer are connected to the two wires of the speed sensing terminals on the ES52 controller. The step-down transformer acts to reduce the false speed signal on the line to a level that the engine controller will not recognize as the engine running. A common size transformer that would serve this purpose would be 24VA.

Step Down Transformer Connections On Speed Sensing Cable

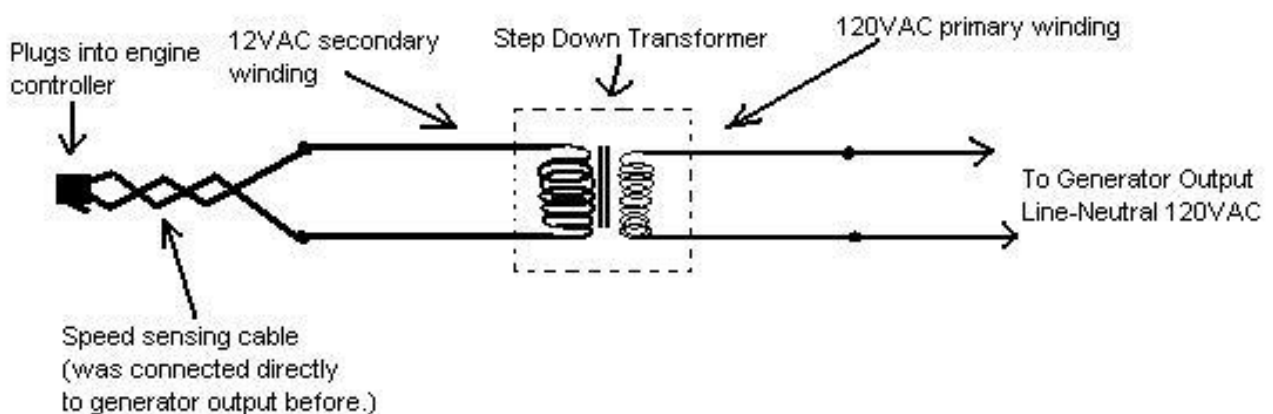

#### 4. Connecting ES52 to a Transfer Switch (or remote device)

The ES52 remote start contacts carry high current, up to 20A peak during starting (for more info see RSC1 and RSC2 in section 2.3 on page 9). If necessary use an external normally open relay to limit the current to the remote device.

Below is an example using the Vigilant transfer switch. Since the Vigilant remote start contacts are rated at 10 Amps an external relay is necessary to ensure the contacts are not damaged.

