



GSC200

Auto Start Engine & Transfer Switch Controller

Installation and User Manual for the GSC200 Controller

Full Version

File: GSC200_R1_1doc
8/12/2008

LIMITED WARRANTY POLICY: DynaGen Technologies Inc. hereafter known as the Seller warrants articles sold hereunder to be free from defects in material and workmanship. These express warranties are the sole warranties of the Seller and any other warranties, expressed, implied in law, or implied in fact, are hereby specifically excluded. The Seller's sole obligation under its warranty shall be, at its option, to either issue a credit, or repair or replace any article or part thereof, which is proved to be defective. Any adjustment of credits will be based upon original billing prices. All warranties shall expire 5 years from date of shipment by the Seller, unless otherwise specified in other written communications from the Seller. Any replacement product provided to the Buyer shall be subject to the original warranty period, which will expire 5 years from the date of shipment of the original article. Notice of claimed breach of warranty must be given within the applicable period. No allowances shall be made to the Buyer for any transportation, duties, brokerage fees, labor costs, or parts adjustments or repairs, or any other work, unless said charges are authorized in writing, in advance, by the Seller. The Seller shall, in no event, be liable for special or consequential damages or for loss of profit. The warranty shall not extend to any articles or parts thereof which have been installed, used, or serviced, other than in conformity with the Seller's application specifications, manuals, bulletins, or instructions, or, if none, shall have been subjected to improper installation, misuse, or neglect. The warranties shall not apply to any materials or parts thereof, furnished by the Buyer, or acquired from others at the Buyer's request and/or to the Buyer's specifications or designs. The foregoing limitations on the Seller's liability in the event of breach of warranty shall also be the absolute limit of the Seller's liability in the event of the Seller's negligence in manufacture, installation, service, or otherwise, with regard to the articles covered hereby, and upon the expiration of the stated warranty period, all such liabilities shall terminate.

RETURNS: If any article is claimed to be defective in material or workmanship, the Seller, upon notice promptly given, will issue a written return material authorization (RMA) with shipping instructions for return to the Seller. All returns must be accompanied by an RMA number or shipments will not be accepted by the Seller. Articles which are returned as defective, but are found to meet the specifications agreed upon, will be subject to a re-testing charge. At the discretion of the Seller, unused and undamaged Standard Products may, under certain circumstances, be accepted back for credit or exchange. A restocking charge of 15% will apply. Unused custom designed products will not be accepted back for credit or exchange.

For questions or comments regarding this product, contact:

DynaGen Technologies Inc.
Phone (902) 562 0133
Fax: (902) 567 0633
Email: sales@dynagen.ca
WEB SITE: www.dynagen.ca

SPECIFICATIONS FOR THE GSC200

Operating Voltage:	7 to 30VDC continuous Zero volts operation for 100mS (assumes supply was 12VDC before initiating starting)
Operating Temperature:	-40 °C to +85 °C (LCD Display operates from to -16 °C to 70 °C)

Front Panel Indications

-High intensity LED's with regulated brightness

LCD Display:

- LCD display for hour meter.

Adjustments

Warm-up:	0 - 200 seconds (After Failure Bypass Feature)
Cool-Down:	0 - 300 seconds (in 5 second increments)
Crank Disconnect:	12 to 140Hz
Overspeed:	40 – 200Hz
Underspeed:	40 – 200Hz
Crank Rest:	4 - 32 seconds (GREEN Engine Run LED will flash during Crank Rest)
Delay on Start:	0 – 59 seconds (GREEN Engine Run LED will flash during Delay on Start)
Crank Tries:	1 to 10
Failure Bypass:	10 – 55 seconds
Low Battery Indication:	7 – 35 VDC

Timer adjustments:

Preheat: 0 - 255 seconds

InputsSpeed Sensing:

-Generator Output Speed Sensing

-Maximum Input Voltage: 300VAC RMS

-Minimum Input Voltage: 0.7VAC RMS Generator Output Sensing

-60Hz Rejection Filter Included

-Loss of Speed Signal Included

Failure Inputs:

Oil Pressure
Coolant Temperature
2 Auxiliary Inputs

-Programmable for switch configuration NO or NC

Protection:

- Reverse polarity protected
- Inputs are electrostatic discharge protected
- Maximum power supply surge before damage: 1500V for 250us

Outputs:

- All outputs switched to +battery (sourcing)
- 2 Auxilliary Outputs: User configurable to one of 6 different options through software.

Connections

- Removable terminal blocks for input and output connections

Programming

- Windows based software interface utilizing the parallel port of your PC
- Needs no power to program using the PC Interface – uses power from parallel port of PC

-Specifications May Change Without Notification

CONTROLLER OVERVIEW

General Failure Conditions

Low Battery Voltage Indication

Oil Pressure Input

High Temperature Input

Auxiliary Inputs

Hour Meter

Exerciser Function

Transfer Switch Controls

Utility Sensing

GENERAL FAILURE CONDITIONS

The following conditions can cause the GSC200 controller to shut down the Engine Generator system unexpectedly.

Low Oil Pressure	Low Oil Failure is indicated by a steady on Red Low Oil pressure Led
High Coolant Temperature	High coolant temperature is indicated by a steady on RED High water temp LED
Overcrank	Overcrank failure is indicated by a steady on RED Overcrank LED
Overspeed	Overspeed failure is indicated by a steady on RED Overspeed LED
Loss of Speed	Loss of speed signal is indicated by a steady on RED Loss of speed LED
Underspeed (If Enabled)	Underspeed failure is indicated by a flashing RED Loss of speed LED The Underspeed failure will only occur when the Underspeed condition remains for more than 3 seconds.

LOW BATTERY VOLTAGE INDICATION

When the battery voltage drops below the user defined set point which can be programmed between 7 and 35VDC, the controller will illuminate the RED Low battery LED. The Low battery LED will be illuminated at any time during OFF, AUTO and MANUAL modes. The Low battery indication will be disabled during failure conditions.

LOW OIL INPUT

The Low Oil Input can be wired to either a NO (normally open) or NC (normally closed) switch (must be correctly defined in software), the switch must be the type that closes to ground on failure. A failure delay can be set in software to be certain that a failure has actually occurred; the delay can be set from 0.5 to 6 seconds in 0.5 second increments.

NOTE: *The Low Oil Input failure is disabled during the failure bypass time.*

HIGH TEMPERATURE INPUT

The High Temperature Input can be wired to either a NO (normally open) or NC (normally closed) switch (must be correctly defined in software), the switch must be the type that closes to ground on failure. A failure delay can be set in software to be certain that a failure has actually occurred; the delay can be set from 0.5 to 6 seconds in 0.5 second increments.

NOTE: *The High Temperature Input failure is disabled during the failure bypass time.*

AUXILIARY INPUTS

There are two available Auxiliary Inputs which can be configured to either indicate a warning or generate a failure in software. Both of these inputs can be wired to either a NO (normally open) or NC (normally closed) switch (must be correctly defined in software), the switch must be the type that closes to ground on failure. A failure delay can be set in software to be certain that a failure has actually occurred; the delay can be set from 0.5 to 6 seconds in 0.5 second increments.

NOTE: *The Auxiliary Input failures are disabled during the failure bypass time.*

HOUR METER

The hour meter displays the total accumulated generator run time. The display represents both hours and minutes in the form 1234.5. The last digit on the hour meter will represent the time in 1/10's of an hour. Please note that the accumulated time displayed on the hour meter can not be reset.

EXERCISER FUNCTION

The exerciser function is programmable only through the front panel buttons. When the controller is first powered up in Auto mode the Engine Run LED will flash to indicate that the Exerciser Function has not been programmed if not already programmed. There are four intervals for the Exerciser selectable, once a week, once every 2 weeks, once every 3 weeks and once every 4 weeks. At programming you must make note of the time of the Exercise event as there is no way to retrieve that information once programming is complete. The exercise cycle will last for 15 minutes plus the Cooldown period (if Cooldown enabled). The exercise cycle can be interrupted by pressing the OFF button during the cycle, but the controller will resume the cycle if returned to AUTO with time remaining in the cycle. How to program the Exerciser Function is explained later in the manual.

TRANSFER SWITCH CONTROLS

The transfer switch controls can either be enabled or disabled in software. This allows the controller to be used only as an Engine Controller. Please note that disabling the transfer switch controls does not disable or turn off the Exerciser Function, it only disables the controller from starting the generator on a loss of utility.

UTILITY SENSING

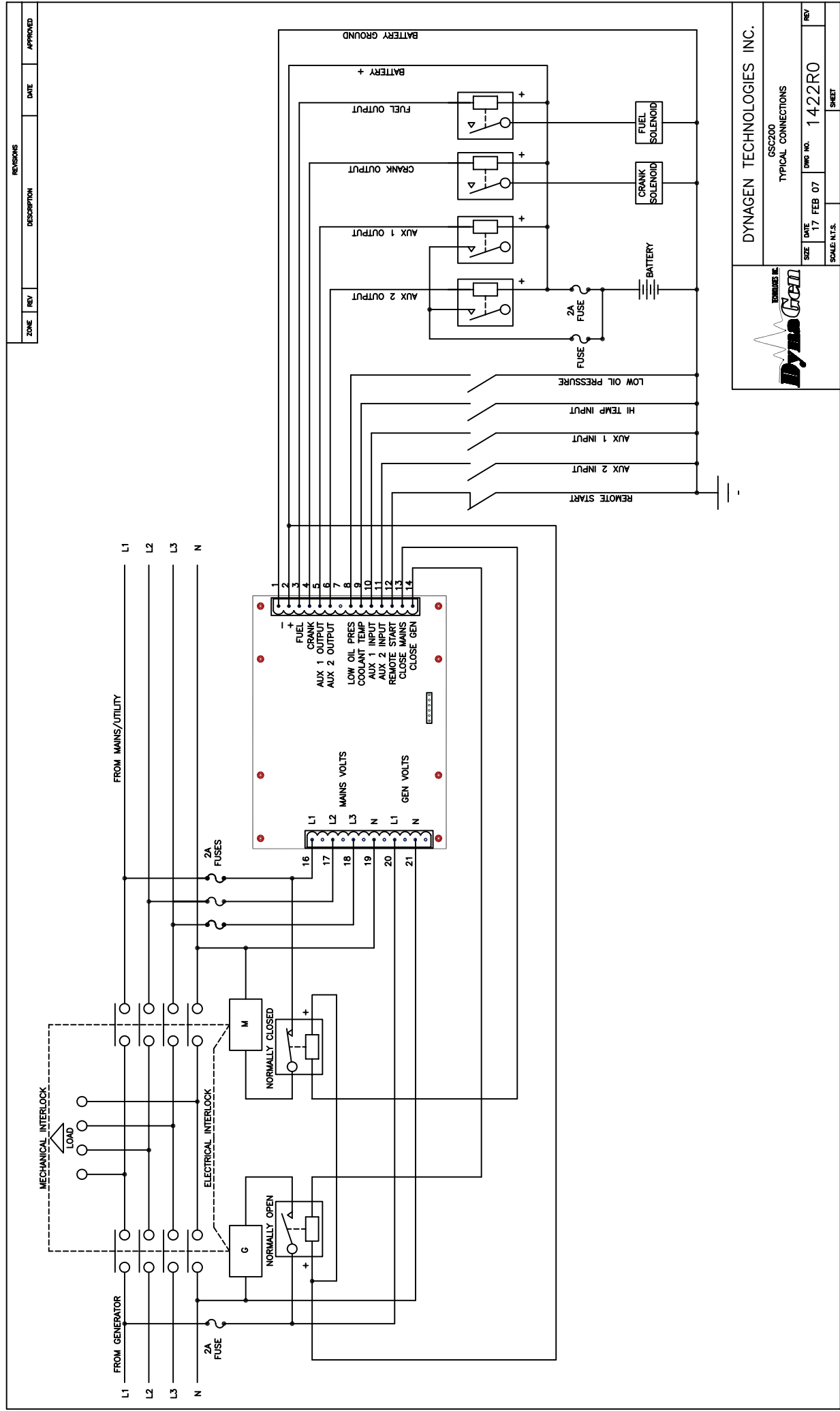

REVISIONS		DATE	APPROVED
ZONE	REV	DESCRIPTION	

DynGen
EXHAUST INC.

DYNAGEN TECHNOLOGIES INC.

GSC200
TYPICAL CONNECTIONS

DATE	DWG NO.	REV
17 FEB 07	1422R0	

SCALE: N.T.S. SHEET

Utility sensing is measured from line to neutral and can accept voltages up to 300VAC. Single or three phase sensing is user selectable in the GSC200 Configurator software.

LED INDICATIONS

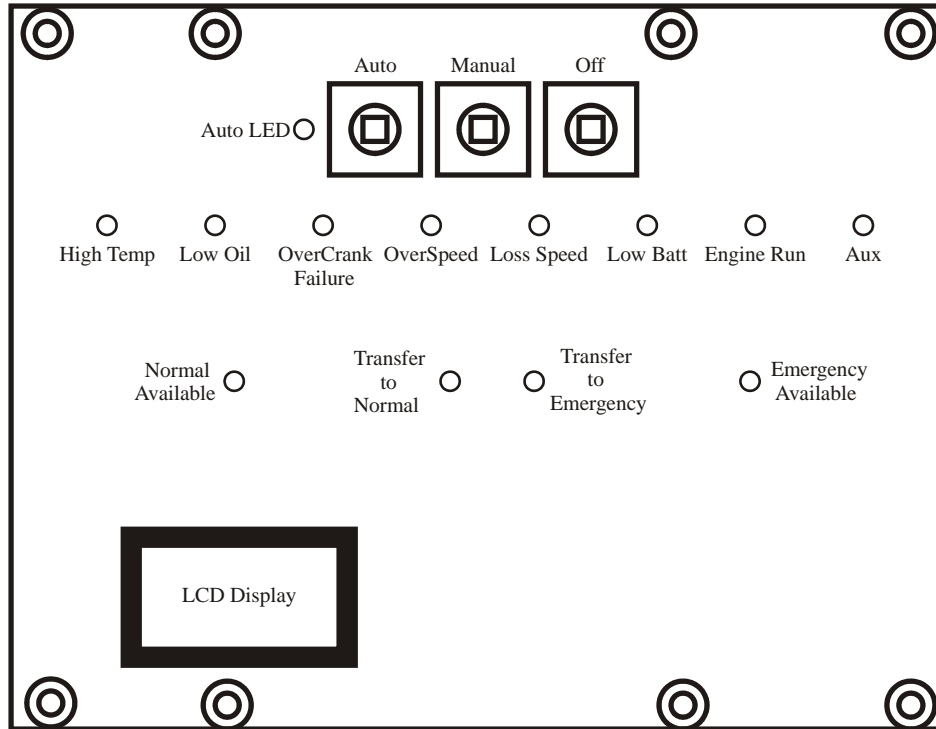

AUTO LED: GREEN

The Auto LED will illuminate when the controller is placed into Auto.

HIGH TEMP LED: RED

The High Temp LED will illuminate when the High Temperature switch activates.

LOW OIL LED: RED

The Low Oil LED will illuminate when the Low Oil switch activates.

OVERCRANK LED: RED

The Overcrank LED will illuminate when the controller completes the selected amount of Crank tries without successfully starting the Engine.

OVERSPEED LED: RED

The Overspeed LED will illuminate when the Engine's speed exceeds the value set by the user unless Overspeed has been disabled in the software.

LOSS OF SPEED LED: RED

The Loss of Speed LED will illuminate when the speed signal drops to zero while the Engine is running.

LOW BATTERY LED: RED

The Low Battery LED will illuminate when the battery voltage drops below the value set by the user.

ENGINE RUN LED: GREEN

The Engine Run LED will illuminate when the engine starts and speed is detected by the controller.

AUXILIARY LED: RED

The Auxiliary LED has two purposes, first as an indication for Auxiliary Output 1, which can be set for one of 6 different functions by the user, and also as an indication for Auxiliary Output 2, which also can be set for one of 6 different functions by the user. Both Auxiliary outputs can also be disabled in the software. When the chosen function of Auxiliary Output 1 goes active the Auxiliary LED will flash as the indication. When the chosen function of Auxiliary Output 2 goes active the Auxiliary LED will be steady on to indicate the failure.

NORMAL AVAILABLE LED: GREEN

The Normal Available LED will illuminate when the Voltage Sensing detects that the Utility is available.

TRANSFER TO NORMAL LED: GREEN

The Transfer to Normal LED will illuminate when the Transfer Switch is in the Normal position.

EMERGENCY AVAILABLE LED: RED

The Emergency Available LED will illuminate when the Voltage Sensing detects that the Generator source is available.

TRANSFER TO EMERGENCY LED: RED

The Transfer to Emergency LED will illuminate when the Transfer Switch is in the Emergency position.

LCD DISPLAY:

The LCD display will show the total time that the generator has ran. This time is displayed when the controller is in Engine run mode and can not be reset.

PROGRAMMING THE GSC200

All of the features of the GSC200 that are user selectable or adjustable can be selected or adjusted by using the GSC200 Configurator, the exception to this is the Exerciser Function which can only be programmed by the use of the front panel buttons.

Programming the Exerciser Function

To enable the Exerciser Function of the GSC200, press and hold the Auto button, the Auto button must remain held until the entire process is complete, after about 8 seconds the GREEN Engine Run LED will blink, after the LED blinks press the Manual button the correct amount of times to set the interval between Exercise cycles. The following chart shows the intervals that correspond to the number of times to press the Manual button.

Number of Button Presses	Interval Time
1	Once Every 1 Week
2	Once Every 2 Weeks
3	Once Every 3 Weeks
4	Once Every 4 Weeks

NOTE: Please make note of the exact time that the programming of the Exerciser Function was done as there is no way to retrieve this information from the controller once programming is complete. This will be the time that the Exerciser will activate each time.

Once you complete the programming of the Exerciser the controller will immediately perform an Exerciser cycle. The cycle begins with the GREEN Engine Run LED beginning to blink for 60 seconds, this is the alert that an Exerciser cycle is about to begin. Once the alert time expires, the generator will start and if LOAD is selected in the Configurator software the transfer switch will transfer to the generator source. If NO LOAD is selected in the Configurator software then the generator will simply run for the duration of the cycle with no transfer from the utility source. The duration of the Exerciser cycle is 15 Minutes plus the Cooldown period if Cooldown is selected in the Configurator software.

Once the Exerciser cycle has begun you can interrupt the cycle by pushing the OFF button, however the time will continue to count down so if the controller returns to AUTO the generator will start.

To disable the Exerciser Function, press and hold the Auto button, the Auto button must remain held until the entire process is complete, after about 8 seconds the GREEN Engine Run LED will blink, after the LED blinks press the OFF button and the Exerciser Function will be disabled.

NOTE: If at any time the battery is disconnected from the controller, the Exerciser Function will be reset to disabled and the controller will again flash the indication that the Exerciser Function is not programmed when the controller is put into Auto mode.