



OPT and AST Series Transfer Switch Technical Bulletin

1.	OPT/AST Series (Discontinued).....	3
1.1	Operation.....	3
1.2	Replacement Relay Boards	8
1.3	RB41 Series: White Molex Connector Info	9
1.4	Troubleshooting	10

1. OPT/AST Series (Discontinued)

1.1 Operation

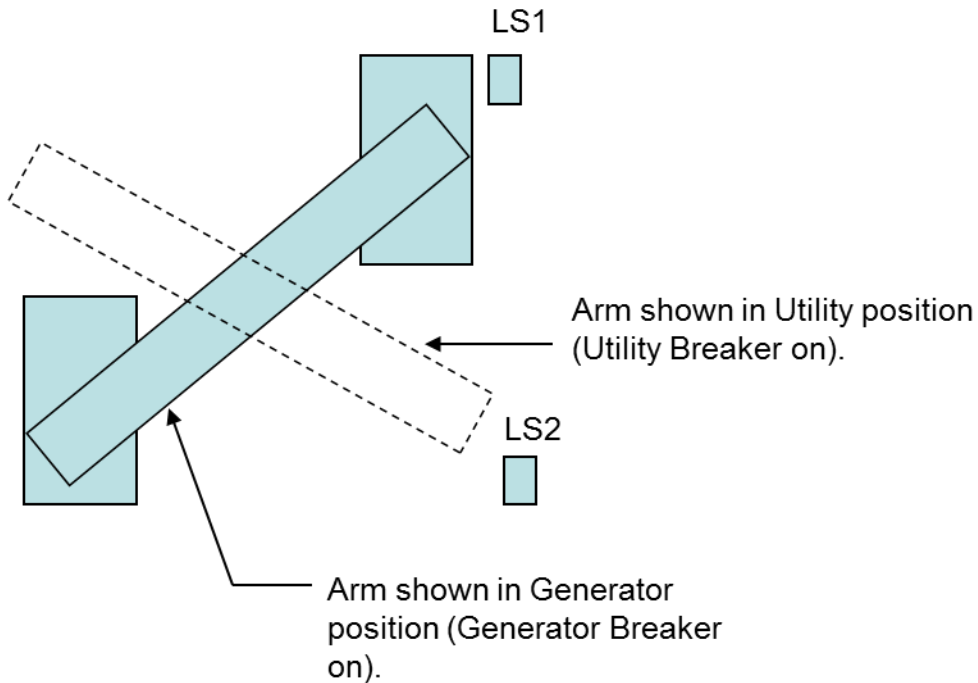

Figure 1 – AST/OPT Transfer Arm

Basic principle of switch operation is a lever arm rotates to switch on the generator breaker or utility breaker. This is done by a Motor [M] that rotates in one direction only.

Two controllers are used: RB41 and an external timing controller such as the TSC3 or ES53. The RB41 does the “sensing” and transfer. The TSC3 controller is responsible for the delays and starting the generator. If the TSC3 controller is not connected to the RB41, the RB41 would transfer immediately upon loss of utility.

Note 1: Older switches may have an RB40 instead. The RB41 is backwards compatible.

Note 2: Older switches may have a TSC1 instead of a TSC3. The TSC3 is backwards compatible.

RB41 Terminals

TB1 Terminal (5 pin)

- 1 – Red Wire – [K4] control
- 2 – Black Wire – Ground for K3 and K4 control.
- 3 – White Wire - [K3] control
- 4, 5 – Brown and Green Wires – RSC signal to start external controller (e.g. TSC3) that utility is lost or an exercise is desired. These two wires are shorted to signal that utility is lost or open to signal utility is available.

TB3 Terminal (4 pin)

- 1 – Exerciser clock start common terminal (Battery voltage is always on this terminal).
- 2 – Exerciser clock start NO terminal. This closes to terminal 1 when the exerciser clock triggers an exercise.
- 3 – AC Neutral to power exerciser clock.
- 4 – AC Power from utility phase A to power the exerciser clock. The clock runs from battery when utility power is not available.

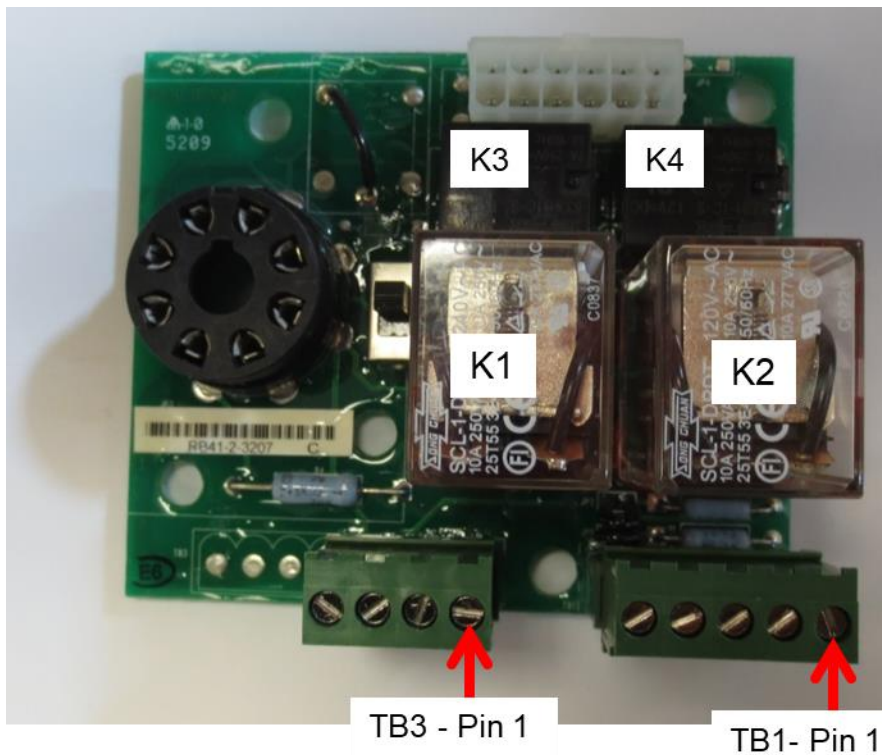

Figure 2 – RB41 Pinout

RB41 – Motor Circuit

[K1] initiates motor movement to transfer to emergency or utility based on utility phase A. Power to the motor is obtained from either the utility or generator side depending on the direction of transfer.

An external controller (e.g. TSC3 or ES53) can delay the transfer by outputting high on contacts K3 and K4 which opens the relay keeping the motor off. If no external controller is connected transfer begins immediately.

Limit switches [LS1 and LS2] are responsible for stopping the motor when the lever arm is in the correct position. If load is not detected when the lever is in the correct position another relay on the relay board [K2] overrides the limit switch to allow the motor to continue to rotate to attempt to turn on the breaker.

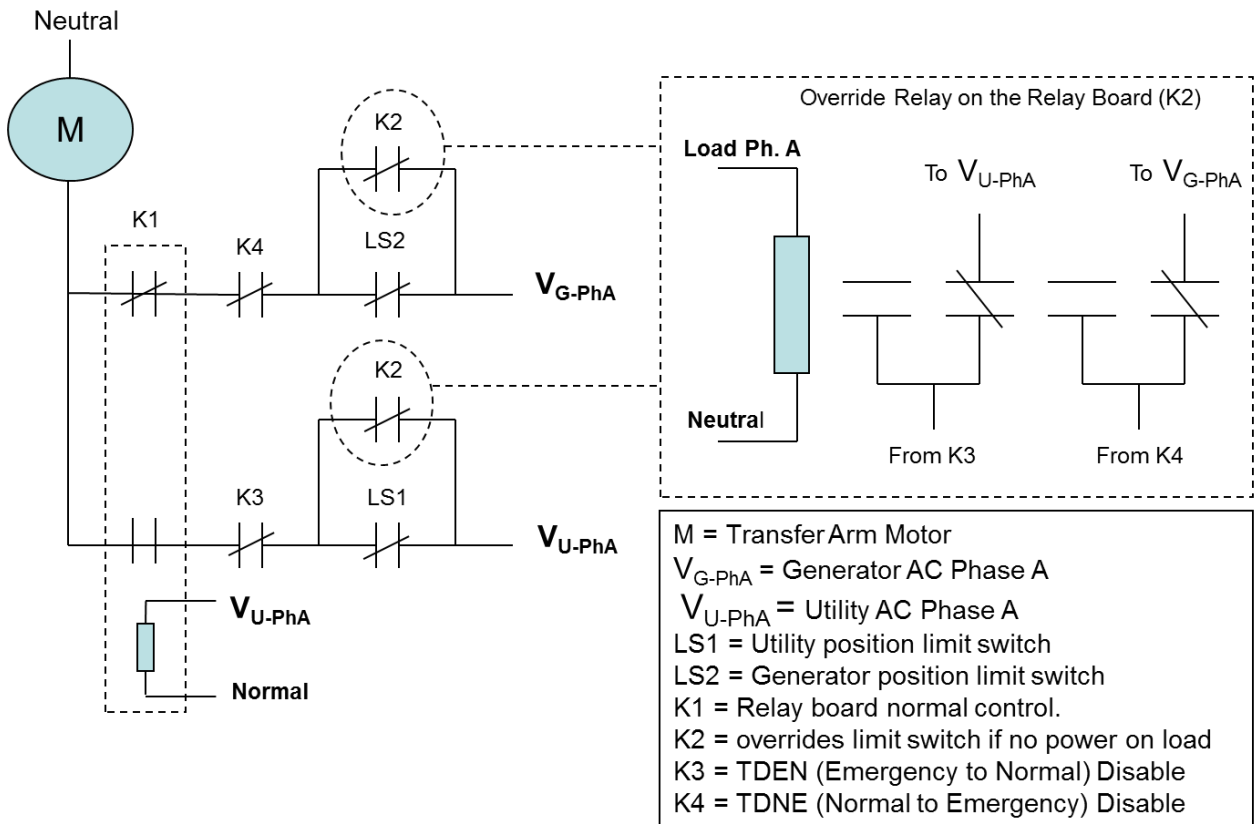

Figure 3 – RB41 Motor Circuit

RB41 – Lost of Utility Start/Stop Logic

For the AST and OPT switches.

When utility power is lost a separate NO contact on the [K1] relay shorts the RB41 terminals TB1-4 and TB1-5 which applies battery positive to TSC3 terminal 9. This tells the TSC3 that utility is lost. When utility is available the contact opens removing the short between RB41 terminals 5-4 and 5-5 removing the voltage on TSC3 terminal 9 which tells the TSC3 utility is available.

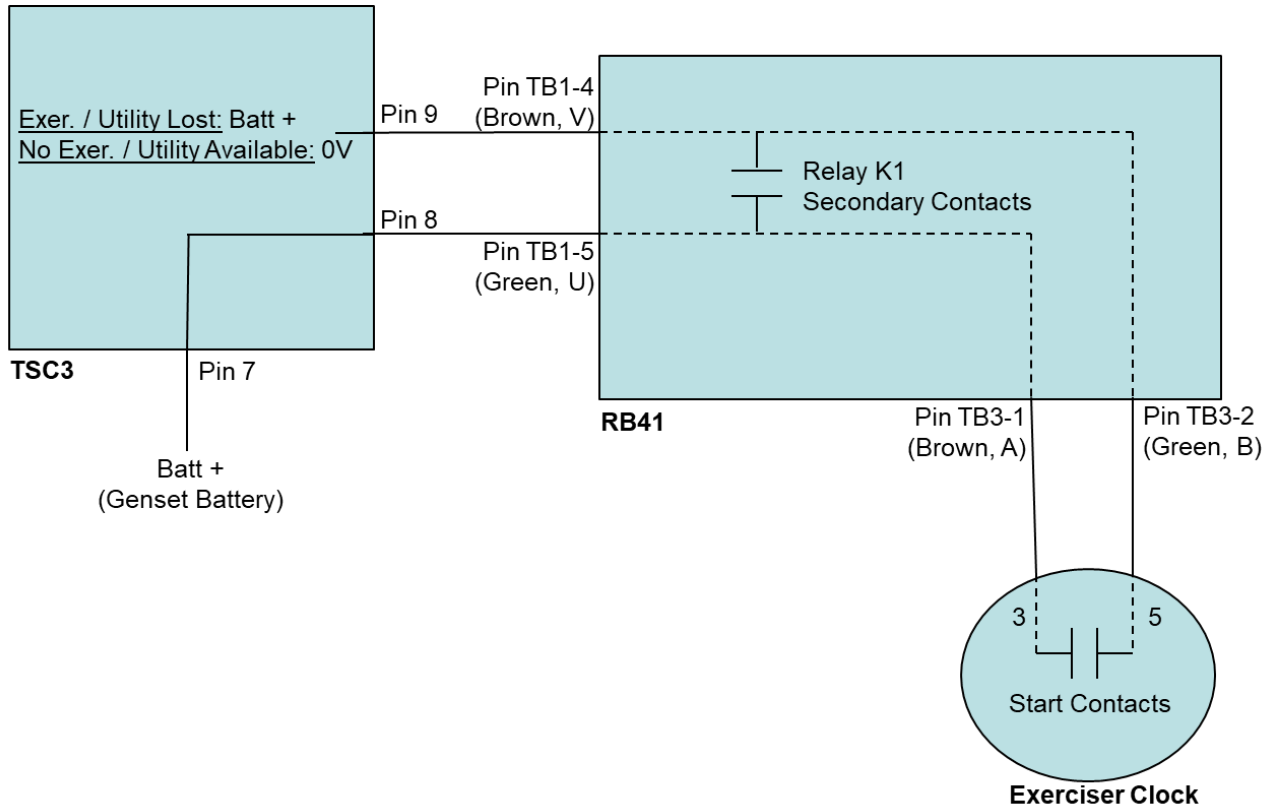

Figure 4 – AST Transfer Switch RB41 control logic

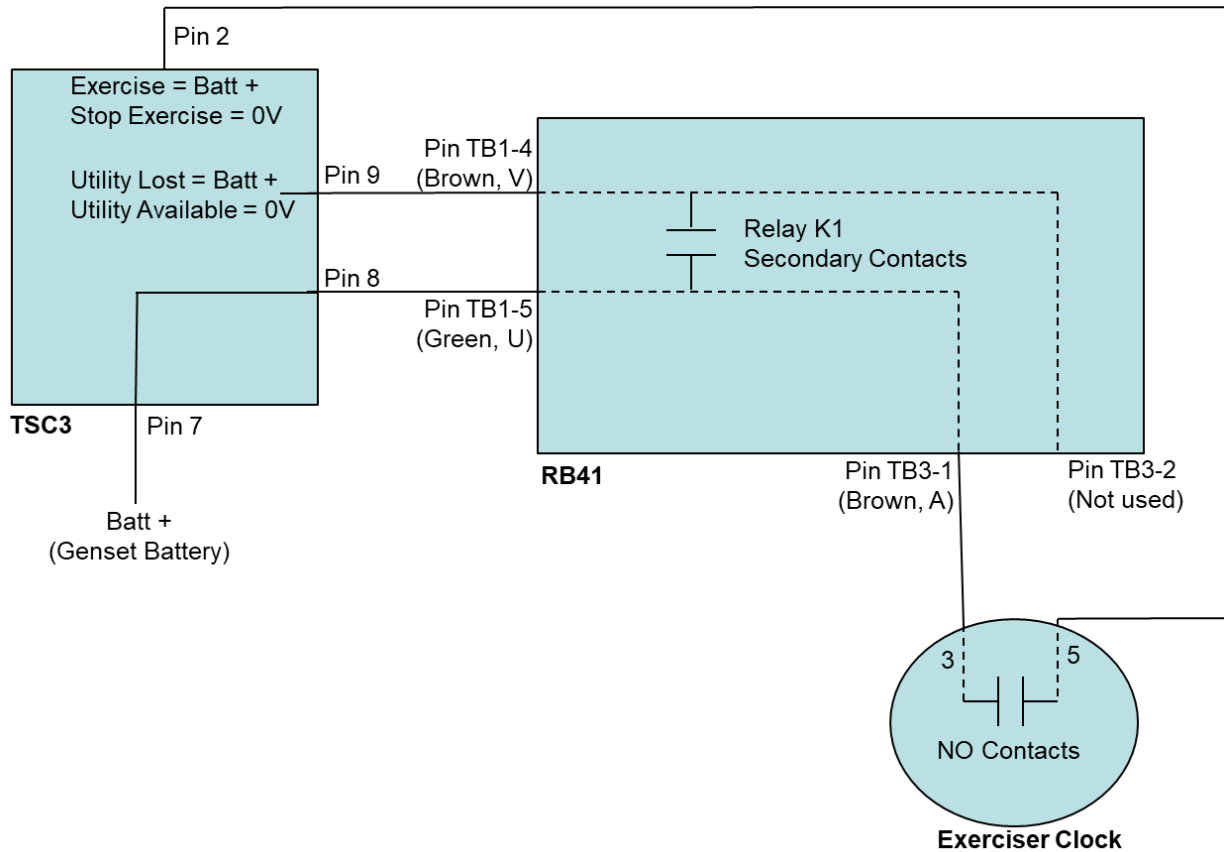

Figure 5 – OPT Transfer Switch RB41 control logic

RB41 – Exerciser Start/Stop Logic

AST Transfer Switch

Very similar to the loss of utility signal except the exerciser clock contact will close instead of the K1 secondary contacts which will signal the TSC3 that utility is “lost” and cause it to start the engine.

OPT Transfer Switch

The exerciser clock will apply 12VDC to the exerciser input on the TSC3. This will tell the TSC3 to do an exercise. When the exercise is finished the exerciser clock will remove the 12VDC which tells the TSC3 that the exercise is done.

In the OPT the TSC3 has a load/no load option and an exerciser output which will turn on a NC relay for the load option to cut utility voltage to the RB41. The RB41 will then transfer to emergency as it thinks utility is lost.

1.2 Replacement Relay Boards

Single phase applications: use RB41-2

Three phase applications: use RB41-3

There are older revisions but all can be replaced with these two. There are two connectors on board: (1) green Euro style connector, (2) white Molex type connector.

See below for photo of RB41-2. RB41-3 is identical except it uses a larger Molex connector (the white connector).

The slide switch (select switch) must be in the off position (towards the white Molex connector) if the voltage sensing relay is not being used. Otherwise if there is no relay in place the RB41 will think there is a utility fault and attempt to switch to emergency.

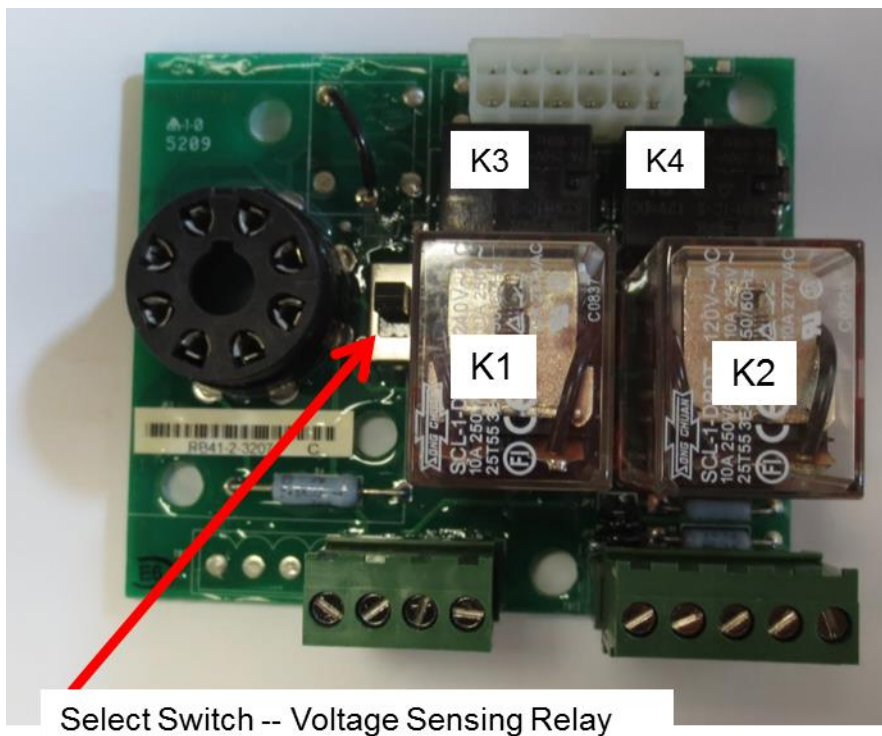

Figure 6 – RB41-2

1.3 OPT Replacement Clock

The Dynagen part number for the exerciser clock is ACC0073.

1.4 RB41 Series: White Molex Connector Info

RB41-2 uses CON0028 (Molex 39-28-1123, 2x6) connector on its board. This is used internally to connect to the contactor and other components of the transfer switch.

RB41-3 is the same board as RB41-2 except it uses CON0038 (Molex 39-28-1123, 2x7) instead of CON0028.

CON0014 (Molex 39-01-2125, 2x6 plug) is the plug that connects to CON0028.

CON0010 (Molex 39-01-2145, 2x7 plug) is the plug that connects to CON0038.

The crimp pins used for these two plugs are CON0015 (Molex 39-00-0039) which are the same as the pins used in the GSC400 Molex connectors.

DWG1410 is a kit of 5 wires with CON0015 crimps.

1.5 Troubleshooting

(1) Motor continues to run for abnormal time or continuously. Power turns on and off (i.e. lights turn on and off).

Breaker is working. Power is being applied to load side.

- Limit switch damaged or not switching on due to wear.
 - o Adjust Limit switch.
- Limit switch works but motor inertia causes motor to continue pass limit switch eventually causing limit switch to close its contacts again. Transfer switch then thinks it has not switched breaker (has no memory) and tries again.
 - o Tighten the central arm pivot. This will provide more friction to arm to prevent motor from overshooting.
- Relay board is bad causing limit switch to be bypassed.
 - o Troubleshoot and replace relay board.
- Was the RB41 board replaced? Check that there is an orange wire from pin 7 of the 2x6 RB41 connector (refer to wiring diagram in manual) to the load side of the transfer switch. Had a case where this was missing.
 - o If missing, add.

(2) Motor continues to run for abnormal time or continuously. Power does NOT turn on and off (i.e. lights do not turn on and off), power remains off.

Breaker not turning on or bad breaker causing no power to be applied to load side of transfer switch. The limit switch override feature causes reattempts to be made to turn on the breaker as it detects no load.

- Breaker good, but not being activated by the arm.
 - o Adjust the arm portion that activates the breaker. Wear can cause the arm not to exert sufficient force against the breaker.
- Bad breaker
 - o Replace breaker

(3) Generator does not start when utility is lost.

- (a) Manually start the generator and confirm there is the proper AC voltage and AC frequency at the emergency lugs of the transfer switch.
 - o If there is an issue address it.
- (b) Remove the two wires from the remote start contacts on the user terminal inside the transfer switch. Touch them together.
 - o The generator starts.
 - Replace the wires and go to the next step.
 - o The generator does not start.

- There is an issue with the wiring for the remote start. Resolve.
- (c) For transfer switches with a TSC3 (or older) measure the voltage between pins 6 and 7. It should read the voltage of the genset battery.
 - If it does not check the battery + and battery neg. connectors to the transfer switch.
- (d) Check that the RB41 board works properly. Shut off utility power to simulate loss of utility. Disconnect the 5pin green connectors from the RB41 board. Manually start the genset. The transfer switch should switch to emergency immediately once the genset has started.
 - The transfer switch does not switch to emergency.
 - The RB41 board could be defective.
 - The transfer switch does switch to emergency.
 - The RB41 is working properly. Plug in RB41 5pin green connector. Leave utility power off. Continue to next troubleshooting step.
- (e) Measure DC voltage across TSC3 terminals 6 and 9.
 - Voltage is same as the genset battery voltage. Continue to next step.
 - Measure zero voltage or much lower than genset battery voltage. Wiring issue in factory harness between RB41 and TSC3. Check for bad or loose wires.
- (f) Remove wires from TSC3 terminals 5 and 11. Measure resistance across terminals 5 and 11. Ensure the TDES (time delay engine start is over); TDES light should come on for TDES and then turn off (unless it is set at zero seconds). Measure when it has turned off.
 - Zero ohms (or near that) is measured.
 - The TSC3 appears to be working fine. Go to step (h).
 - Infinite ohms (no continuity) is measured.
 - There is an issue with the TSC3 or relay on the TSC3. Go to the next step.
- (g) Check the relay on the TSC3 board. There should be 120 Ohms across the coils. Check continuity between command and normally open contacts in the unpowered and powered states.
 - Relay is defective.
 - Replace relay.
 - Relay is not defective.
 - Go to the next step.
- (h) Remove the two wires on the remote start contacts on the user terminal switch. Measure the remote start contacts on the terminal switch.
 - Zero Ohms is measured.

- The transfer switch is operating fine.
- Infinite Ohms is measured.
 - There is an issue in the factory wiring between the TSC3 and the user connections terminal block. Maybe a wire is loose or broken.

(4) Generator does not start on an exercise.

- (a) Check that the exerciser clock is programmed correctly including the time and day. The exerciser could be set to run manually. If it is programmed correctly continue to the next step.
- (b) Unplug the wires from the common (terminal 3) and the normal open (terminal 5) contacts on the back of the exerciser. Caution: the clock is powered from high voltage on terminals 1 and 2.

Check that during an exercise that there is zero ohms (continuity) between terminals 3 and 5.

- If there is not continuity.
 - The exerciser clock is defective. Replace.
- If there is continuity.
 - Go to the next step.
- (c) Check that the two wires between terminals 3 and 5 on the exerciser and the RB41 are not shorted or open.
- (d) Repeat all the steps in “Generator does not start when utility is lost.”