

DYNAGEN[®]

power controls you can trust

Vigilant Series

Automatic Transfer Switch



VTS 100A/200A Automatic Transfer Switch

Installation and User Manual

Full Version File: MAN-0071 R1.8, VTS 100-200A User Manual.doc (September 2013)

Thank You for Purchasing This DynaGen Product

Please Read Manual before Installing Unit

Receipt of Shipment and Warranty Return Information

Upon receipt of shipment, carefully remove the unit from the shipping container and thoroughly examine the unit for shipping damage. In case of damage, immediately contact the carrier and request that an inspection report be filed prior to contacting DynaGen.

All returned items are to be shipped prepaid and include a Return Material Authorization (RMA) number issued by DynaGen. RMA forms are available by contacting DynaGen Technical Support through the contact methods listed below.

Limited Warranty

For warranty information refer to the standard terms and conditions of sale at <http://www.dynagen.ca>.

Dynagen VTS Webpage

For up-to-date manuals and other information please see the VTS section of the Dynagen website at: U <http://www.dynagen.ca/products/VTS.htm>U

Table of Contents

VTS 100A / 200A Specifications	4
1.0 Vigilant Product Series	5
1.1 Receiving, Handling, and Storage	6
1.1.1 Receiving:	
1.1.2 Handling	
1.1.3 Storage	
1.2 Vigilant Product Number Identification	7
2.0 Vigilant Series Installation and Wiring	8
2.1 General Information	
2.2 Mounting Location	
2.3 Recommended Upstream Protection	
2.4 Power Connections	
2.5 Lug Torque Connections	
2.6 VTS 1000/2000 Series Customer Connections	
3.0 Vigilant Series General Operation	14
4.0 Vigilant Series adjustments and settings	15
4.1 System adjustment	
4.2 Timer adjustment	
4.3 Test adjustment	
5:0 Open Type Transfer Switches	19
6.0 Manual Transfer of Mechanism	20
7.0 Recommended Maintenance	21
8.0 Drawings	22
9.1 VTS 100A 2P N1/3 General Arrangement	
9.2 VTS 200A 2P N1 General Arrangement	
9.3 VTS 200A 2P N3 General Arrangement	
9.4 VTS1 100/200A Wiring Diagram	
9.5 VTS2 100/200A Wiring Diagram	
9.0 Exerciser/External LED	27
10.0 Service Notes	30

VTS 100A / 200A Specifications



Vigilant Series Transfer Switches do not support Delta configurations.

Vigilant Series	<u>1000 series</u> Controls not included	<u>2000 series</u> Controls included	
UL1008	Optional Standby rated only.		
AC Current Rating	100A, 2-pole	200A, 2-pole	
AC Voltage Rating	120/240V		
	AC Voltage sensing is line to neutral.¹		
Ambient Temperature Rating	113 ⁰ F (45°C) at 100A 131 ⁰ F (55°C) at 90A 149 ⁰ F (65°C) at 75A 158 ⁰ F (70°C) at 70A Do not exceed 158 ⁰ F (70°C).	113 ⁰ F (45°C) at 200A 131 ⁰ F (55°C) at 180A 149 ⁰ F (65°C) at 150A 158 ⁰ F (70°C) at 140A Do not exceed 158 ⁰ F (70°C).	
RSC Rating	10A Maximum		
DC Operating Voltage	12/24 VDC (Voltage Range 9 - 30 VDC)		
DC Power Cons.	25mA @ 12 VDC		
Control Setting Ranges	Function	Range	Setting
	Time Delay Engine Start	3-32 seconds	13 seconds (1.56Vdc@ TP J2-1)
	Time Delay Transfer to Emergency	11-64 seconds	21 seconds (0.78Vdc@ TP J2-2)
	Time Delay Transfer to Normal	9-256 seconds	256 seconds (5.00Vdc@ TP J2-3)
	Time Delay Engine Cooldown	0-256 seconds	256 seconds (5.00Vdc@ TP J2-4)
	Normal Line Sensing Under Voltage	Dropout (11-18%) Pickup (6-13%) (+/- 2% accuracy)	Dropout (18%) Pickup (13%) (+/- 2% accuracy)
	Normal Line Sensing Under Frequency	5-12% (+/- 1% accuracy)	12% (+/- 1% accuracy)
	Emergency Line Sensing Under Voltage	Dropout (11-18%) Pickup (6-13%) (+/- 2% accuracy)	Dropout (18%) Pickup (13%) (+/- 2% accuracy)
Over/Under Voltage Sensing	Dropout (11-18%) Pickup (6-13%) adjustable Percentage above or below normal voltage to recognize an unacceptable voltage condition. (+/- 2% accuracy)		
Over/Under Frequency Sensing	5-12% adjustable Percentage above or below normal freq to recognize an unacceptable frequency condition. (+/- 1% accuracy)		
Exerciser Timer	Included on 2000 series transfer switch		
Test switch	Included on 2000 series transfer switch		

UL Withstand / Closing Ratings	22,000A when used with properly rated 100A circuit breaker 25,000A when used with properly rated 200A circuit breaker
Lug Capacities	100A – 1/0 to 14 AWG 200A – 1/0 to 250MCM
Overall Dimensions	100A/Open Type – 13”x 12”x 0.5”@240 / 18”x 18”x 0.5”@480 100A/Enclosure – 16”x 14”x 06”@240 / 20”x 20”x 06”@480 200A/Open Type – 22”x 18”x 0.5” 200A/Enclosure – 24”x 20”x 06”
Weight	100A @ 25 LB, 200A @ 51 LB

* Applies to 2000 series only.

¹One of the connected L-N phases must be below the under-voltage threshold to initiate transfer sequence.

1:0 Vigilant Product Series:

The VTS series transfer switch consists of 2 uniquely designed product series. Product series consist of the 1000 or 2000 series. Each series has been specifically designed with its own unique operating functionality.

The 1000 series is represented by the VTS1 product identifier. The 1000 series provides a basic transfer switch mechanism with no control circuitry provided. The 1000 series is specifically designed with a 12 position terminal block provided to allow customer addition of suitable control circuitry as desired.

The 2000 series is represented by the VTS2 product identifier. The 2000 series is specifically designed with all required sensing circuitry provided. The sensing circuitry allows automatic transfer of an electrical load to a stand-by power source in the event of an over/under voltage or frequency condition on any or all phases of the normal power source. Upon the restoration of the normal supply, the electrical load will be automatically re-transferred to the normal power source. Optional engine controls may be added to allow the safe operation of the generator including proper engine failure shutdown.

All Vigilant Transfer switch mechanisms incorporate a double throw action switching device for automatic transferring. The VTS mechanism is a contactor operated device controlled by a set of normal and emergency solenoids. Manual operation is also provided for manual transfer of the load between the power sources if necessary.

VTS 1000 Series



VTS 2000 Series



1:1 Receiving, Handling, and Storage



Receiving:

Every effort is made to ensure that your vigilant transfer switch arrives at its destination undamaged and ready for installation. The packing is designed to protect the transfer switches internal components as well as the enclosure. Care should be taken to protect the equipment from impact at all times. Do not remove the protective packaging until the equipment is at the installation site and ready to be installed.

When the transfer switch reaches its destination, the customer should inspect the shipping box and transfer switch for any signs of damage that occurred during transportation. Any damage should be reported to a DynaGen representative once a thorough inspection is complete.

A shipping label affixed to the shipping box includes a variety of product and shipping information, such as items and Customer numbers. Make certain that this information matches your order information.

Each transfer switch enclosure is packaged in its own box. Heavy-duty cardboard sides surround the enclosure for protection. Do not discard the packing material until the transfer switch is ready for installation.

Important documents will be found inside the Vigilant transfer switch enclosure protective packaging box including the Vigilant transfer switch user manual, VTSC100 controller manual (2000 series) and system wiring diagrams are included.



Handling:

As previously mentioned, each Vigilant transfer switch is packaged in its own individual box. Protect the equipment from impact at all times and do not double stack. Once the transfer switch is at the installation site and ready to be installed, the packaging material may be removed.



Storage:

Although well packaged, this equipment is not suitable for outdoor storage. If the transfer switch is to be stored indoors for any period of time, it should be stored with its protective packaging in place. Protect the transfer switch at all times from excessive moisture, dirty conditions, corrosive conditions, and other contaminants. It is strongly recommended that the package-protected equipment be stored in a climate-controlled environment of -20 to 65°C (-4 to 149°F), with a relative humidity of 80% or less. Do not stack other equipment on top of the stored switches.

1.2 Vigilant Product Number Identification



The Vigilant Transfer Switch product numbering scheme provides significant information pertaining to a specific model. The product Number Identification Table (see Table 1) provides the required interpretation information. An example is offered to initially simplify the process.

A product number VTSX-XXXX-X-XXX-XX-X-XX-XX would consist of a combination of information from the following table.

TABLE1: IDENTIFICATION TABLE

Position 1-4	Position 6-9	Position 11	Position 13-15	Position 17-18	Position 20	Position 22-23	Position 25-26
Series	Amperage	Phase	AC Voltage	DC Voltage	Neutral Delay	Enclosure	Labeling
VTS1=1000 VTS2=2000	0100=100A 0200=200A 0400=400A 0600=600A 1000=1000A 1250=1250A	2=single 3=three 4=four	240=240V 208=208V 480=480V	12=12V 24=24V	X=none D=Delay	N1=nema1 N3=nema3 N4=nema4 NX=Open	LS=DynaGen LX=Custom

Example: The product number VTS2-0100-2-240-12-X-N1-LS would be described as follows:

The transfer switch has the VTSC100 controls included. The transfer switch is designed for a single phase 240V system with a current rating of up to 100A maximum. The transfer switch may be installed in a 12VDC system. The transfer switch does not come with Delay on Neutral option (TDNP) and shipped in a Nema 1 enclosure. The transfer switch includes DynaGen labeling.

VIGILANT SERIES™
TRANSFER SWITCH

SERIAL NUMBER

RATING: VOLTS HZ

 AMPS PHASE

SYSTEM VOLTS

MODEL NUMBER

MANUF. DATE

2:0 Vigilant Series Installation and Wiring:

2:1 General Information:

All Vigilant transfer switches are factory tested and approved. Customer installation requires the mounting of the transfer switch as well as all external wiring for normal and emergency operation. Once the transfer switch is properly installed, it should be visually inspected and approved before any testing is performed.



Vigilant Series Transfer Switches do not support Delta configurations.



CAUTION: Adequate lifting means must be used to lift and mount the transfer switch during installation. Failure to do so could result in personal injury.

2:2 Mounting Location:

All Vigilant transfer switches require that adequate lifting means are used to install the switch at its mounting location. Be certain to choose a location that offers a flat mounting surface which is capable of supporting the transfer switch (see product specifications for proper weight details). Caution must be taken at the installation site to make sure the site is free from excessive moisture, fluctuating temperature ranges, dust, corrosive materials etc. Before any drilling takes place be certain the drilling area is free of any hazards including electrical wiring, piping etc. Extreme caution should be exercised when any installation and drilling are performed to protect the transfer switch from any debris including contaminants, filings etc. Any debris within the transfer switch may result in a system malfunction.

2:3 Recommended Upstream Protection

When protected by a circuit breaker rated at 100/200A maximum. This switch is suitable for use on a circuit capable of delivering not more than:

22,000A RMS SYMMETRICAL AT 240V FOR 100A SWITCHES
25,000A RMS SYMMETRICAL AT 240V FOR 200A SWITCHES

*For suitable circuit breakers see table 2, page 10

Use copper or aluminum wiring 60/75C rating for power terminals.



WARNING: Power lines may carry high voltage which can cause serious injury or death. Extreme caution must be exercised when any power connections are being installed to the transfer switch. All power connections must be de-energized before any installations are performed.

2:4 Power Connections:

Proper power cables need to be installed to the transfer switch and should be installed by qualified professionals only. Improper installation or connections of these power cables are extremely dangerous and may cause severe injury or death. All power connections are to be connected to the proper lugs which are included on the switch contactor and neutral block assembly. Connect the Normal, Emergency, Neutral and load cables to the terminals which are clearly marked on the transfer switch (see figure 1). Verify that all connections are correct before tightening lugs. All power cable lug connections must be tightened to the proper torque values as shown in table 3.

FIGURE 1: Power Cable Connection Locations

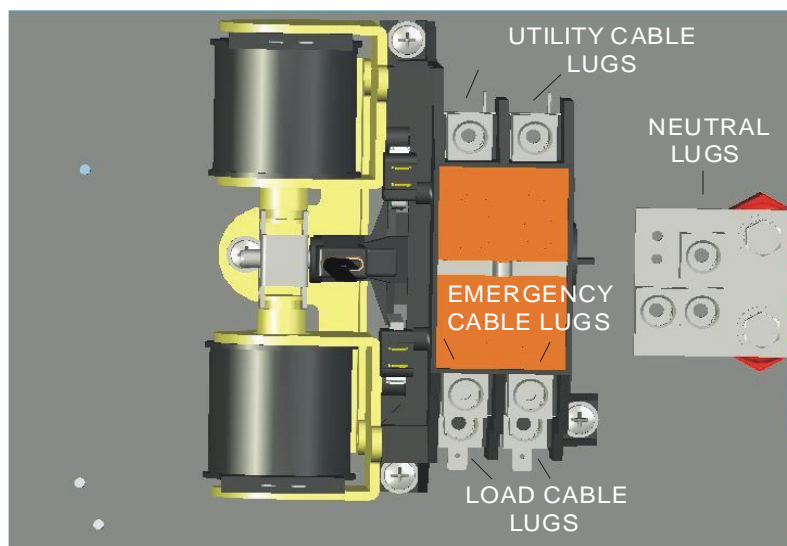

WARNING: Be certain to install the supplied transparent protective shield to the switch mechanism after the proper connections are performed. The protective shield can be found attached to the inside of the enclosure.

TABLE 2A: 100A Suitable Circuit Breakers

Cat. No.	Manufacturer	Electrical Ratings
HED4	SIEMENS	125 A, 240 V, 100 KA
QCHW	CH	125 A, 240 V, 22 KA
FCL	CH	100 A, 240 V, 200 KA
FB	CH	100 A, 240 V, 200 KA
FDC	CH	150 A, 240 V, 200 KA
FI	Square D	100 A, 240 V, 200 KA
ED4, ED6	Siemens	125 A, 240 V, 65 KA
HED4, HED6	Siemens	125 A, 240 V, 100 KA
CED6	Siemens	125 A, 240 V, 200 KA

TABLE 2B: 200A Suitable Circuit Breakers

Cat. No.	Manufacturer	Electrical Ratings
SF	GE	250 A, 240 V, 65 KA
BHW	CH	225 A, 240 V, 25 KA
FD	CH	225 A, 240 V, 65 KA
HFD	CH	225 A, 240 V, 100 KA
JDB, JD	CH	225-250 A, 240 V, 65 KA
HJD	CH	225-250 A, 240 V, 100 KA
JDC	CH	250 A, 240 V, 200 KA
DK, KD, KDB	CH	400 A, 240 V, 65 KA
HKD	CH	400 A, 240 V, 100 KA
KDC, LCL, LA	CH	400 A, 240 V, 200 KA
KI	Square D	250 A, 240 V, 200 KA
LE, LX	Square D	400 A, 240 V, 100 KA
LXI	Square D	400 A, 240 V, 200 KA
FD6-A, FXD6-A	Siemens	250 A, 240 V, 65 KA
HFD6	Siemens	250 A, 240 V, 100 KA
CFD6	Siemens	250 A, 240 V, 200 KA
TFL	GE	225 A, 240 V, 100 KA
THLC2	GE	225 A, 240 V, 200 KA
SFL, SFP	GE	250 A, 240 V, 100 KA

The following chart shows the required electrical tightening torque for specific power cable wire sizes.

TABLE 3A: 100A Lug Torque Values

AWG or circular mill size	Tighten torque in inch pounds	
	Screw driver	External drive wrench
14	35	75
12	35	75
10	35	75
8	40	75
6	45	110
4	45	110
2	50	150
1	50	150
1/0	50	180

Wire size range 1/0 to #14 AWG copper using illSCO lug # CA5-SP

TABLE 3B: 200A Lug Torque Values

Internal socket size across flats in inches	Tightening torque in inch pounds
5/16	275

Wire size range 1/0 to 250MCM copper using illSCO lug # CA6-RP

2.5 VTS 2000 Series Customer Connections

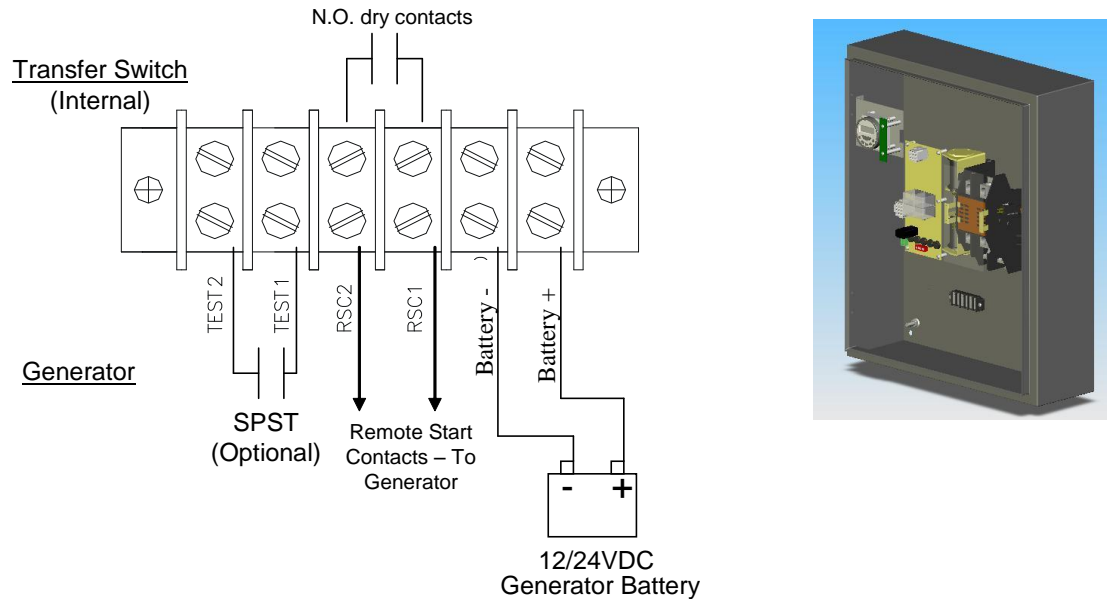

- Please note the VTS2000 Series Transfer Switch consists of the above 6 position terminal block for customer connections.
 - **Battery +** and **Battery -** must be connected for operation of the VTSC100 controller. Either 12VDC or 24VDC. **A 1A fuse should be placed on the Battery + connection.** Do not use an isolated power supply to power the controller as the controller requires a reference to neutral for AC Sensing which it obtains from the distribution system via battery -.
 - **RSC1** and **RSC2** need to be connected to the remote start/stop connections of the generator to allow automatic starting. These are N.O. dry contacts.
 - An optional customer supplied test switch may be installed by the customer using the **Test 1** and **Test 2** terminals. A closed circuit between the test connections will simulate a utility failure. See wiring diagram for details.

The **battery charger** needs to be of high quality. Low quality battery chargers will often go into full recharge mode due to VTSC100 (VTS2 controller) current draw. This will quickly wear out the battery.

2.6 VTS 1000 Series Customer Connections

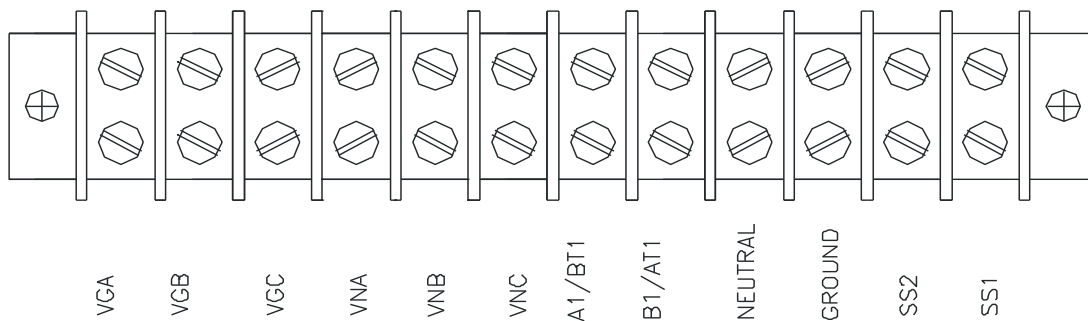

* Please note the VTS1000 Series Transfer Switch consists of the above 12 position terminal block for customer sensing connections. See wiring diagram for details

VGA – Emergency Voltage Sensing Phase A

VGA – Emergency Voltage Sensing Phase B

VGA – Emergency Voltage Sensing Phase C

VNA – Normal Voltage Sensing Phase A

VNA – Normal Voltage Sensing Phase B

VNA – Normal Voltage Sensing Phase C

A1/BT1 – VNA Contactor Sensing

B1/AT1 – VGA Contactor Sensing

Neutral – Power Neutral Line

Ground – Ground Connection Location

SS2 – Remote Start contacts*

SS1 – Remote Start contacts*

*Applying 12VDC between SS2 and SS1 will energize a relay causing a manual transfer to emergency of the transfer switch.

3:0 Vigilant Series General Operation:

The VTS series transfer switch in combination with DynaGen's VTSC100 timing module will allow for the automatic transfer of an electrical load to a stand-by power source in the event of an over/under voltage or frequency condition on any or all phases of the normal power supply.

In the event of an over/under voltage or frequency condition of utility power, the onboard VTSC100 sensing circuitry will begin the initiation of the transfer process. Upon initial sensing of a loss of utility power the Vigilant series transfer switch is specifically designed to allow an engine start time delay period (TDES) to expire before starting the generator. This engine start time delay is user adjustable from the VTSC100 preventing unnecessary engine starts from a temporary loss of utility. In the event the utility source is not restored after the engine start time delay has expired the remote contacts will close sending a signal to the generator's automatic start controller.

When the VTSC100 senses that the generator has started, and is within acceptable limits, the transfer switch will wait until the normal to emergency time delay (TDNE) has expired before switching to the neutral position. While in the neutral position the transfer switch will transfer back to normal supply if the utility is restored. With no utility source the transfer switch will stay in the neutral position until the delay on neutral time has expired allowing the transfer switch to temporarily stop at the neutral position during either the normal to emergency or emergency to normal transfers. The temporary stop allows controlled isolation between both normal and emergency sources. After the neutral delay has expired the transfer switch will complete the transfer to the destination source. All connected loads will be transferred to the emergency power source.

While the transfer switch is in the emergency position, the VTSC100 will constantly monitor the utility source voltage and frequency status. Once the utility source is restored the transfer switch will wait until the emergency to normal time delay (TDEN) has expired before switching to the neutral position. The TDEN delay is user adjustable from the VTSC100 to prevent unnecessary transfers caused by momentary utility restoration conditions. If the utility source remains stable after the emergency to normal time delay expires the transfer switch will transfer to the neutral position. The transfer switch will stay in the neutral position until the delay on neutral time has expired. If the utility source fails during this delay period, there will be a transfer back to the emergency position. When the delay on neutral time expires the transfer switch will transfer to the normal position. All connected loads are transferred to the normal power source.

When connected loads are transferred back to the normal power source an engine cooldown period (TDEC) will be initiated allowing the generator to run in a no load condition. This engine cooldown time delay is user adjustable from the VTSC100 allowing the generator to continue running for an adjustable period after the normal utility is restored.

4:0 Vigilant Series adjustments and settings:



Danger: Never adjust settings while energized.
Completely isolate all sources of power from controller and transfer switch mechanism before making any adjustments.

The Vigilant Series adjustments and settings may be made from the onboard VTSC100 transfer switch controller (* VTS 2000 series only). The general settings and adjustments for the VTS 2000 series are as follows. Please refer to the VTSC100 controller user manual for detailed information on adjustments.

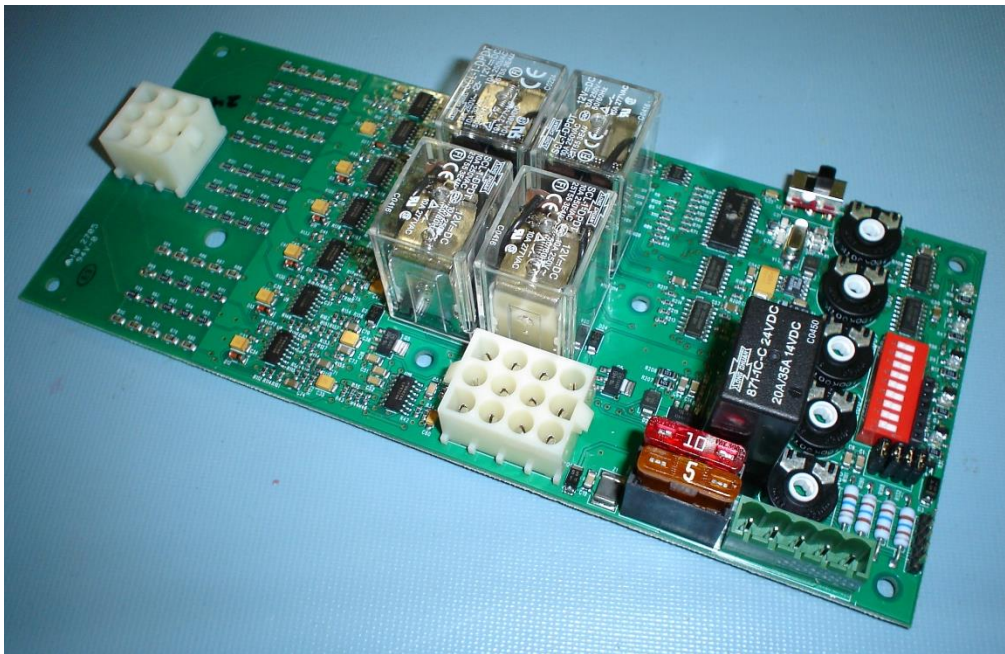

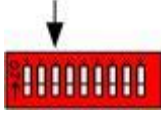

4.1 System Adjustments:

1: 120/240 or 277/480 VAC: Switch #1.

DO NOT ADJUST: Please note that this setting is factory set and must not be adjusted by the customer. Improper system voltage settings may cause the controller to function improperly. 120/240 and 277/480 VAC systems require specific hardware, so simply adjusting this setting in the field will not convert the system voltage of the board.

VTSC100 boards used in the VTS 100A/200A Series Automatic Transfer Switch must have switch location #1 in the OFF position (configured for 120/240 VAC system).

2: 50/60 HZ: Switch #2.

The dip switch located on the VTSC100 is used to set the unit for 50 or 60 Hz systems. When switch location #2 is on, the system is configured for 60 Hz. When switch location #2 is off, the unit is configured for 50 Hz systems.

3: Load/No Load: Switch #3.

The dip switch located on the VTSC100 may be used for load/no load exerciser testing. When switch location #3 is on, the system is configured for a load test condition allowing transfer to an emergency power source. When switch location #3 is off, the unit is configured for a no load test condition with no transfer to an emergency power source. This setting applies to the engine exerciser test only. Please refer to the VTSC100 user manual for a more advanced and detailed outlook.

4: Under/Over voltage: Switch #4, 5, and 6.

The dip switch located on the VTSC100 may be used to set the Over/Under voltage setting. Depending upon the positions of Dip Switch locations 4, 5 and 6 the VTSC100 will determine the percentage range to recognise a utility failure. The failure percentage adjustments can range from 11 to 18 percent of the normal power source for dropout and 6 to 13 percent for pickup. Switch 4, 5, and 6 off for 18% and on for 11% dropout. Please refer to the VTSC100 user manual for a more advanced and detailed outlook.

5: Under/Over Frequency: Switch #7, 8, and 9

The dip switch located on the VTSC100 is used to set the Over/Under frequency setting. Depending upon the positions of Dip Switch locations 7, 8 and 9 the VTSC100 will determine the percentage range to recognise a utility failure. The failure percentage adjustments can range from 5 to 12 percent of the normal power source. Switch 7, 8, and 9 off for 12% and on for 5% range. Please refer to the VTSC100 user manual for a more advanced and detailed outlook.

Timing Adjustments: (*VTS 2000 series only*)

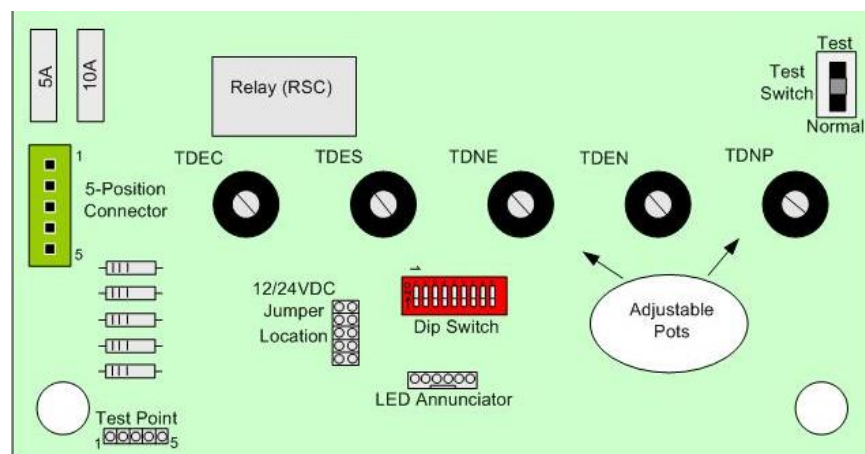

- 1: **TDES:** Time Delay Engine Start: This delay prevents unnecessary engine starts. When the VTSC100 determines a utility failure it will wait for the engine start time delay to expire before trying to start the generator.
- 2: **TDNE:** Time Delay Normal to Emergency: This delay allows the generator to stabilize before any load is transferred. This normal to emergency time delay allows the generator to be fully running before supplying power to a load.
- 3: **TDEN:** Time Delay Emergency to Normal: This delay allows the utility source to be monitored for stability. This emergency to normal time delay allows the utility to be monitored for the set amount of time to confirm that it is fully restored and stable.
- 4: **TDEC:** Time Delay Engine Cool: This delay allows the engine to continue running after the transfer switch returns to the normal position. When the VTSC100 recognizes that the transfer switch is in the normal position after a emergency to normal transfer, the generator will continue to run under a no load condition until the engine cool time delay has expired.
- 5: **TDNP:** Time Delay Neutral Position: This delay is not available on the VTS 100A/200A Series Automatic Transfer Switch. It is only available on the 600A series and above.

Testing Adjustments: (*VTS 2000 series only*)



1: **Controller test switch:**

Manual testing of DynaGen’s VLC 2000 series transfer switches may be achieved by manual adjustment of the test switch located on the VTSC100. The controller test switch will allow manual testing of the transfer switch. The purpose of the test switch is to simulate a utility power failure. Normally the test switch would be set to the normal position, allowing proper sensing for normal utility faults. To simulate a utility fault when no fault actually exists, the test switch would be set to the test position allowing the transfer switch to transfer to the emergency position. After testing, utility power can be restored simply by setting the test switch back to the normal position.

2: **Remote test switch:**

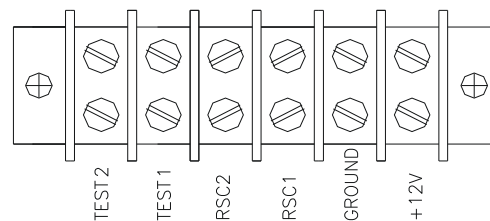

The remote test switch will allow remote testing of the transfer switch. The purpose of the remote test is to perform a manual test of the transfer switch. The remote test switch may be installed by the customer; the switch would be installed between the test 1 and test 2 on the terminal block. Normally the test switch would be set to the Disable position, allowing proper sensing for normal utility faults. To simulate a utility fault when no fault actually exists, the test switch would be set to the Enable position allowing the transfer switch to transfer to the emergency position. A SPST test switch rated at a minimum of 1A should be used.



3: **Exerciser**

The purpose of the exerciser is to perform a test of the transfer switch either manually or automatically. The exerciser may be customer adjusted to any specific time or day in which to perform a test. The exerciser can perform a test for a load or no load condition. For details instructions on operational and setting instructions see the “Exerciser” section on page 27.

5:0 Open Type Transfer Switches:

Open type options allow transfer switches to be shipped with no enclosures. All open type UL approved transfer switches will be required to be placed in a minimum size enclosure to allow proper spacing between electrical components and the enclosure wall. The following chart shows the minimum required dimensions to allow the safe operation of these Switches.

Transfer Switch Amperage Rating	Enclosure Dimensions (Height x Width x Diameter)
100A@240V	16 x 14 x 06
100A@480V	20 x 20 x 06
200A	24 x 20 x 06

The transfer switch must be in accordance with the following requirements:

For models VTS 1000 or 2000 series rated at 200A or below:

1. The minimum spacing requirements per UL-1008 must not be less than 1/4" through air and 3/8" over the surface of the insulating material. These measures must exist between any uninsulated live part and another uninsulated live part of opposite polarity, uninsulated grounded part other than the enclosure or any exposed metal part.



6:0 MANUAL TRANSFER OF MECHANISM



WARNING: Manual transferring is not recommended. If performing an emergency manual transfer, be certain to isolate the transfer switch from all power and load sources. Never transfer under load.

Removable handle for manual transfer



Manual transfer handle lever location

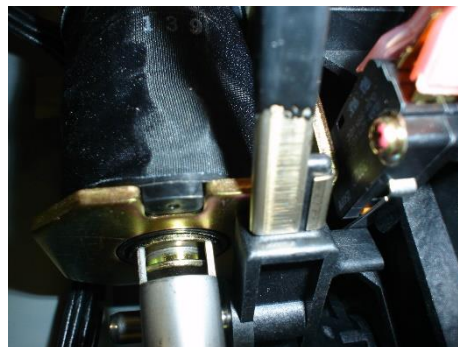

Manual transfer handle position

Manual transferring is not recommended. If the transfer switch fails to transfer in an emergency, an optional manually transfer may be performed. Caution must be taken to confirm that the transfer switch is isolated from all possible load sources before transferring. Please note the flat side of the removable handle must face away from the power connection side of the switch mechanism as seen in the “Manual transfer handle position” photo above for easy transferring. Always remove the handle from the manual transfer handle lever location after each transfer.

- In 100/200A transfer switches, the manual transfer lever located on the contactor is used to manually transfer between the normal (utility) and emergency (generator) position. With the lever facing up toward the normal side, the switch will be in the normal position. With the lever down facing toward the emergency side, the switch will be in the emergency position.

7:0 RECOMMENDED MAINTENANCE



WARNING: When performing any maintenance of the mechanism, isolate the transfer switch from all possible sources of power.



Periodically inspect all terminals (load, line and control), and all fasteners for any loose parts or wiring.

Test the transfer switch operation upon initial installation. Periodically check for any excessive wear on any mechanical operating parts or wiring connections. Clean or replace parts when necessary.

All transfer switch parts are made of corrosion resistant material or is plated, coated or painted for corrosion protection.

Procedure	Action
Making the transfer switch safe for inspection and maintenance.	Disconnect all possible power sources before switch inspection.
Inspect transfer switch location for possible safety issues	Inspect mounting location for any safety or fire issues. Inspect for dirt, wiring damage and mechanical damages.
Inspect transfer switch for loose hardware.	Check all hardware including controller, exerciser, terminals etc. for any looseness due to vibrations etc.
Check for any overheating due to loose connections	Check for any discoloration, melting or blistering of any wiring or connections
Perform regular testing of transfer switch	Perform regular testing of the switch to check for proper operation in case of emergency

8:1 VTS 100A 2P N1/3R ARRANGEMENT

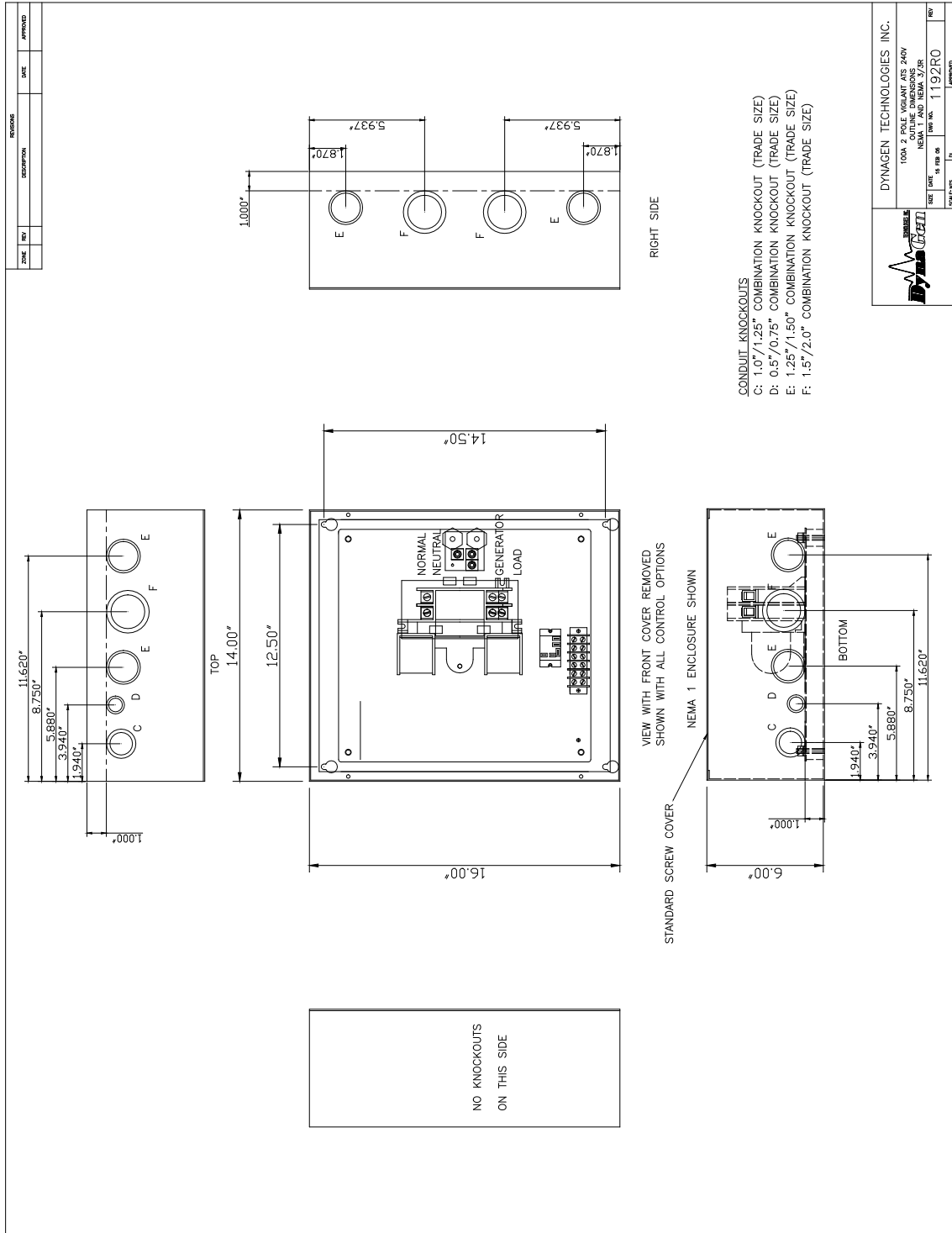

8:2 VTS 200A 2P N1 ARRANGEMENT

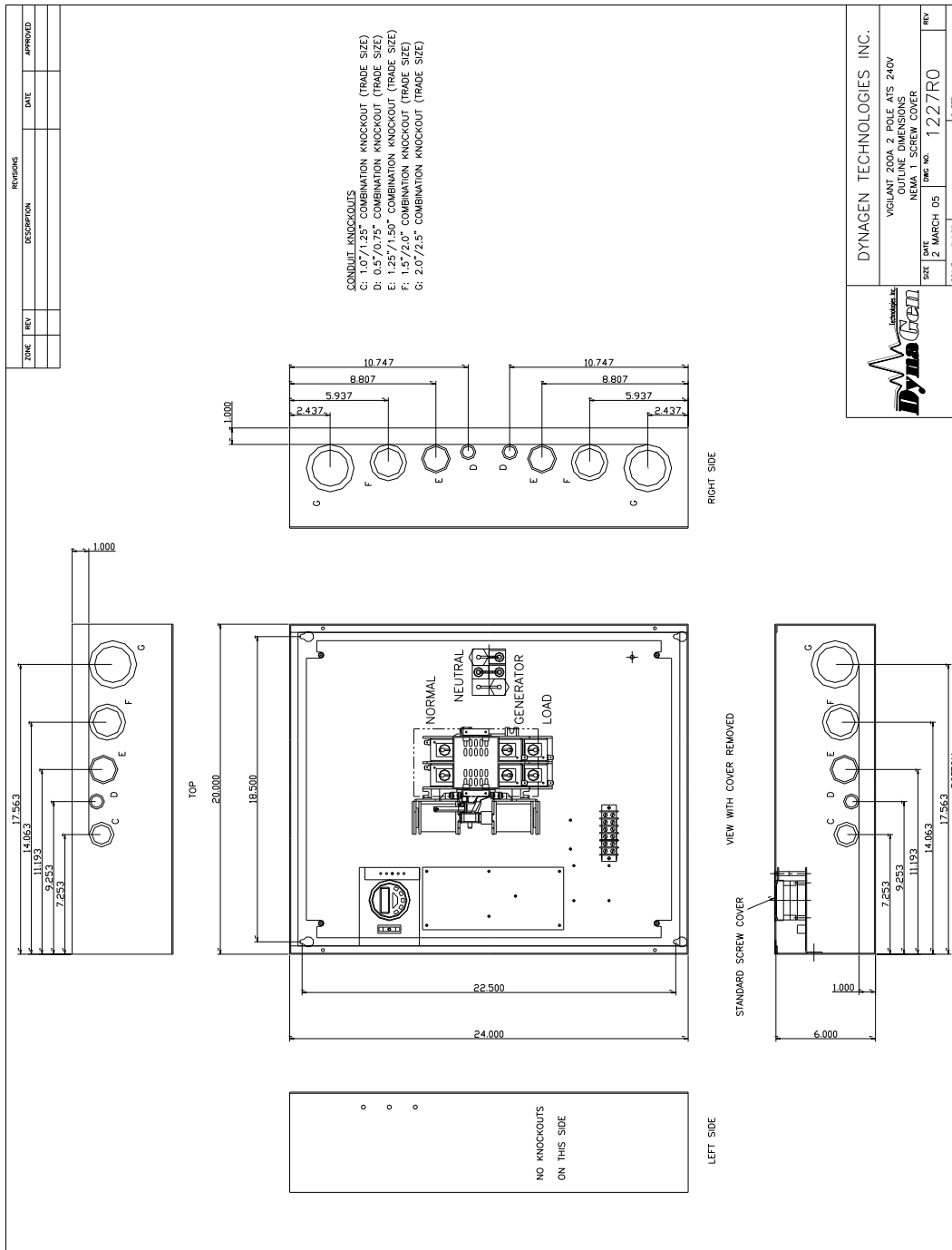

8:3 VTS 200A 2P N3R ARRANGEMENT

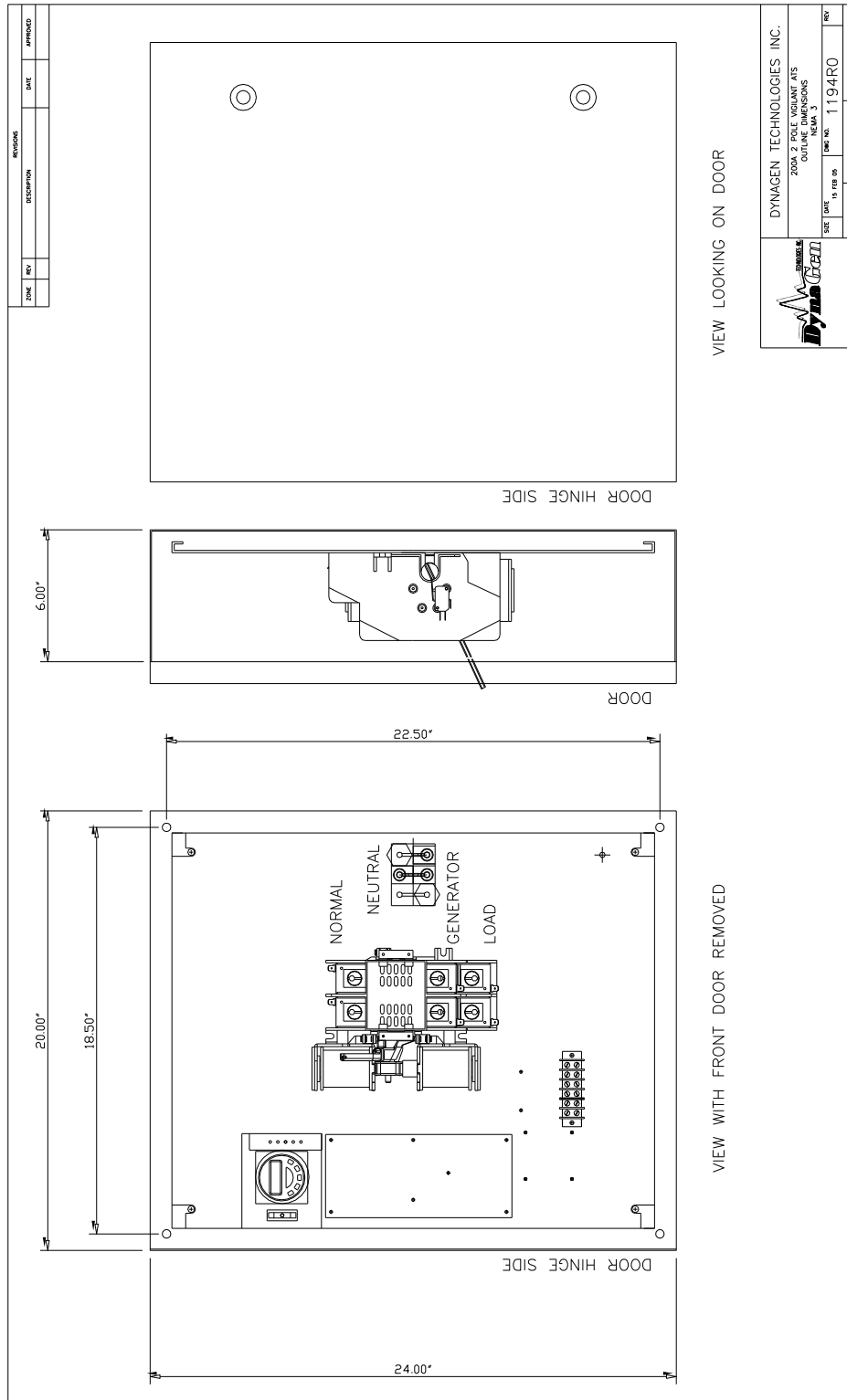

8:4 VTS1100/200-2-120/240V WIRING DIAGRAM

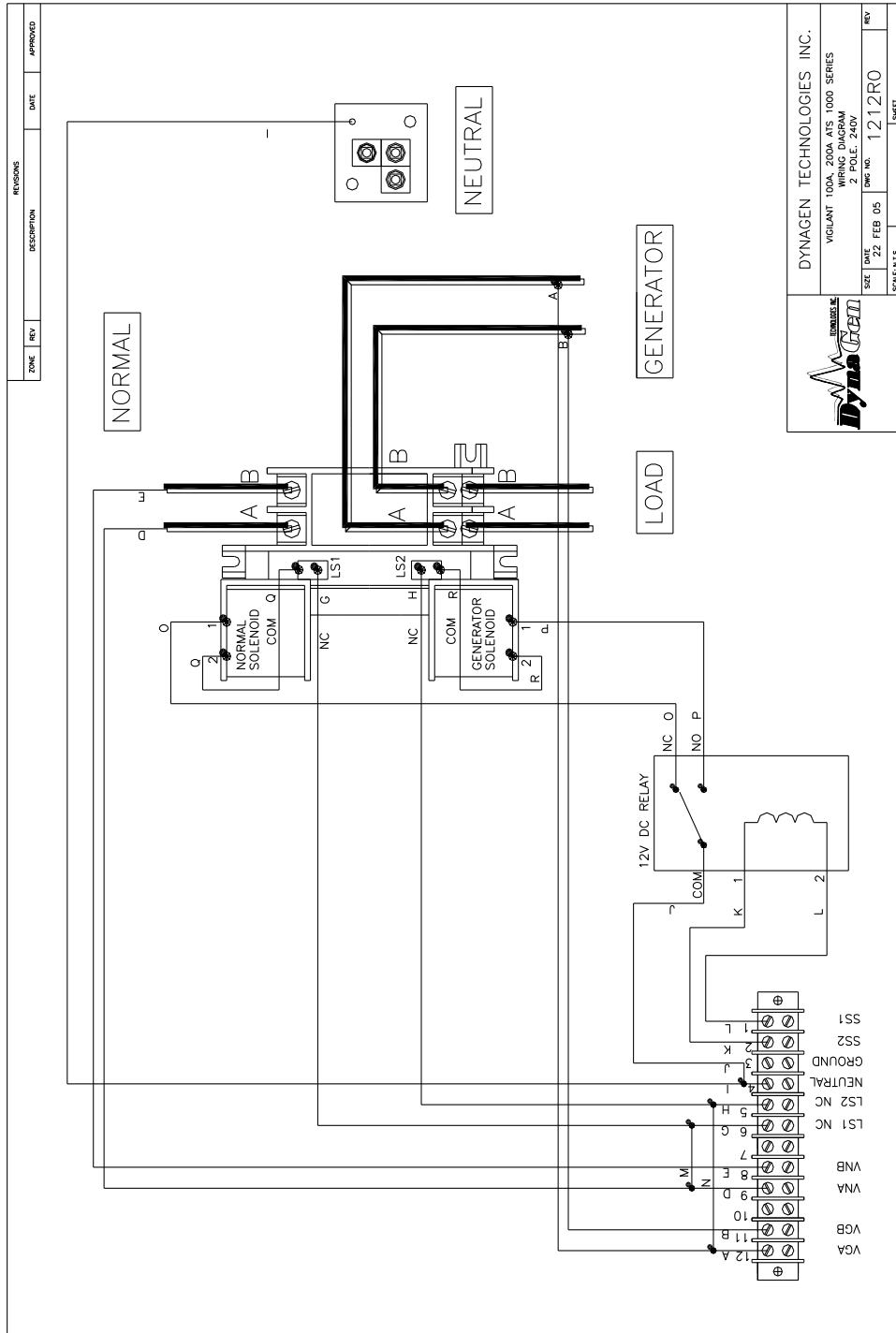

8:5 VTS2100/200-2-120/240 WIRING DIAGRAM

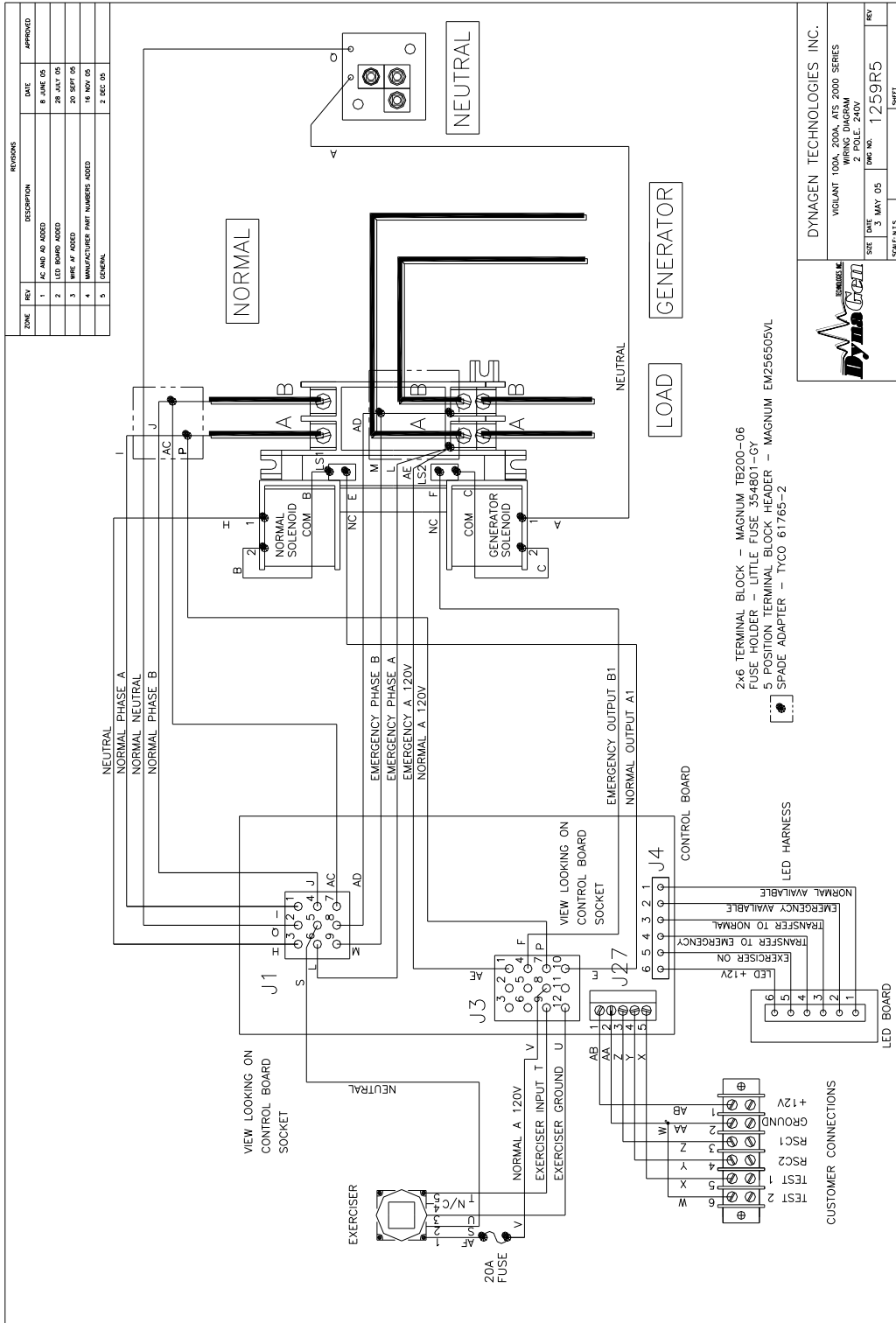

9.0 ENGINE EXERCISER AND EXTERNAL LED ANNUNCIATION

Introduction

All Vigilant 2000 series transfer switches include an external engine exerciser and LED annunciation. The engine exerciser is easily adjustable from outside the transfer switch enclosure. External LED indication is included on all Vigilant 2000 series switches allowing visual controller status. The user may set the engine exerciser to simulate a utility power failure and test the functionality of the transfer switch system. The exact day and time may be specified for testing. External LED indication is available for normal available, emergency available, transfer to normal, transfer to emergency and exercise/test run illumination is explained in detail in the VTSC100 user manual. The functions of the exerciser time clock are described below. The exercise time clock is used to set specific times to test the transfer switch operation. The RESET BUTTON initializes the time clock erasing any previous program. The following will explain how to:

1. Set current time and date
2. Set program timing
3. Review your program
4. On/Auto/Off mode



NEMA 1



NEMA 3

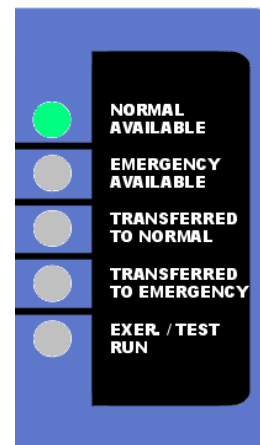

Note: The exerciser clock has a backup battery. The clock runs off the battery when utility power is not available. The battery is not rechargeable.

Clearing the exerciser

Clear the timer before continuing below. To do this, press the round button just above the Minute button.

Set current time and date:

1. Press Clock and Day buttons until current day shows. Release both buttons for current day setting.
2. Press Clock and Hour buttons until current hour shows. Release both buttons for current hour setting.
3. Press Clock and Min buttons until current minute shows. Release both buttons for current minute setting.

Set program timing:

1. Press timer button on the exerciser clock. The “1ON” will appear at the left side of the display. The “1ON” represents when the testing start will begin.
2. Press Day button to select the program day period. There are 10 possible choices to choose from which can be selected by repeatedly pressing the Day button. The 10 possible selections are:

1. Mo. to Su.	6. Fr.	11. Mo. to Sa.
2. Mo.	7. Sa.	12. Mo. to We.
3. Tu.	8. Su.	13. Th. to Sa.
4. We.	9. Mo. to Fr.	14. Mo., We., Fr.
5. Th.	10. Sa. to Su.	15. Tu., Th., Sa.
3. Press Hour button to set hour.
4. Press Min button to set minute.
5. After setting the above testing start time, press the Timer button. After pressing the Timer button the “1OFF” will appear at the left side of the display. The “1OFF” represents when the testing will end.
6. Repeat the above steps 2, 3 and 4 to set the time when the system test is to end.
7. Press the Clock button to start the exerciser clock.

Note: Unused ON and OFF times must have dashes not zeros. The time of day is displayed in the 24-hour notation, so 00:00 is midnight.

Program review:

1. Repeatedly press Timer button to advance display to each subsequent “On” or “Off” user settings.
2. The user set Days and Times will be displayed.
3. To make a change in a specific setting, Repeat Set Program timing above.

On/Auto/Off mode:

1. The On/Auto/Off mode may be selected by pressing the manual button.
2. When the On mode is selected, the transfer switch will go directly to the test mode. The test mode will stay active until the On mode is not selected.
3. When the Auto mode is selected, the timer will monitor the user settable program times. The transfer switch will be tested using the programmed start and end times.

Note: go to Off mode first then back to the Auto Mode when coming from the On mode. The generator will continue to run if Auto is selected directly from Run.

4. When the Off mode is selected, the timer will not monitor any user settable program times. The exerciser will not signal to start the generator when it is in the “off” mode.

When the transfer switch is not connected to an energized utility source, the exerciser timer will use an internal battery for memory storage. With the exerciser in the OFF position very little current draw is required. With the exerciser in the ON position a larger current draw is required. With the exerciser in the AUTO position very little current draw is required when the program is not initiated. See chart below for internal battery current draw:

Exerciser Position	Current Draw
ON	80 uA/Hour
OFF	5 uA/Hour
AUTO (program not initiated)	5 uA/Hour
AUTO (program initiated)	80 uA/Hour

The internal battery current draw would not be applicable when an energized utility source is supplying power to the switch.

SERVICE NOTES-100A VIGILANT ATS 1000 and 2000 series

<u>CONTENTS</u>	<u>PAGE</u>
Replacement Parts Identification. _____	31
Wiring Diagram and Wiring Harness Identification. _____	31
Control Board Replacement. _____	31
Switch unit Replacement. _____	34
Switch Lug Replacement. _____	36
Timer Replacement. _____	37
LED Board Replacement. _____	37
Wiring Harness Replacement. _____	38
Neutral Plate Replacement. _____	39
Neutral Plate Lugs Replacement. _____	39

REPLACEMENT PARTS Figure 1

The listing below identifies replacement parts. Order by using the description and stock code number. In addition, provide the serial number of the transfer switch in question.

<u>Description</u>	<u>Stock Code Number</u>
100A Contactor	SWT0038
Control Board 12 volt relay. 240v working. no neutral delay.	VTSC100-240-12-X
Control Board 24 volt relay. 240v working. no neutral delay.	VTSC100-240-24-X
100A Contactor and Neutral Lugs	CON0121
100A Neutral Plate	DWG1185R3
100A Neutral Insulator	INN0001
Timer (2000 series only)	ACC0073
LED Board (2000 series only)	VTS-ANNL
12v dc Relay (1000 series only)	RLY0032

WIRING DIAGRAMS and WIRE HARNESS

<u>Vigilant Switch Model</u>	<u>Wiring Diagram</u>	<u>Wire Harness</u>
VTS2-0100-2-240-X	1259R5	1267R5
VTS1-0100-2-240-X	1212R1	1272R1

It is recommended that after completing any of the following procedures, a test be performed to verify the proper operation of the transfer switch.



WARNING: When replacing any parts of the mechanism, isolate the transfer switch from all possible sources of power.

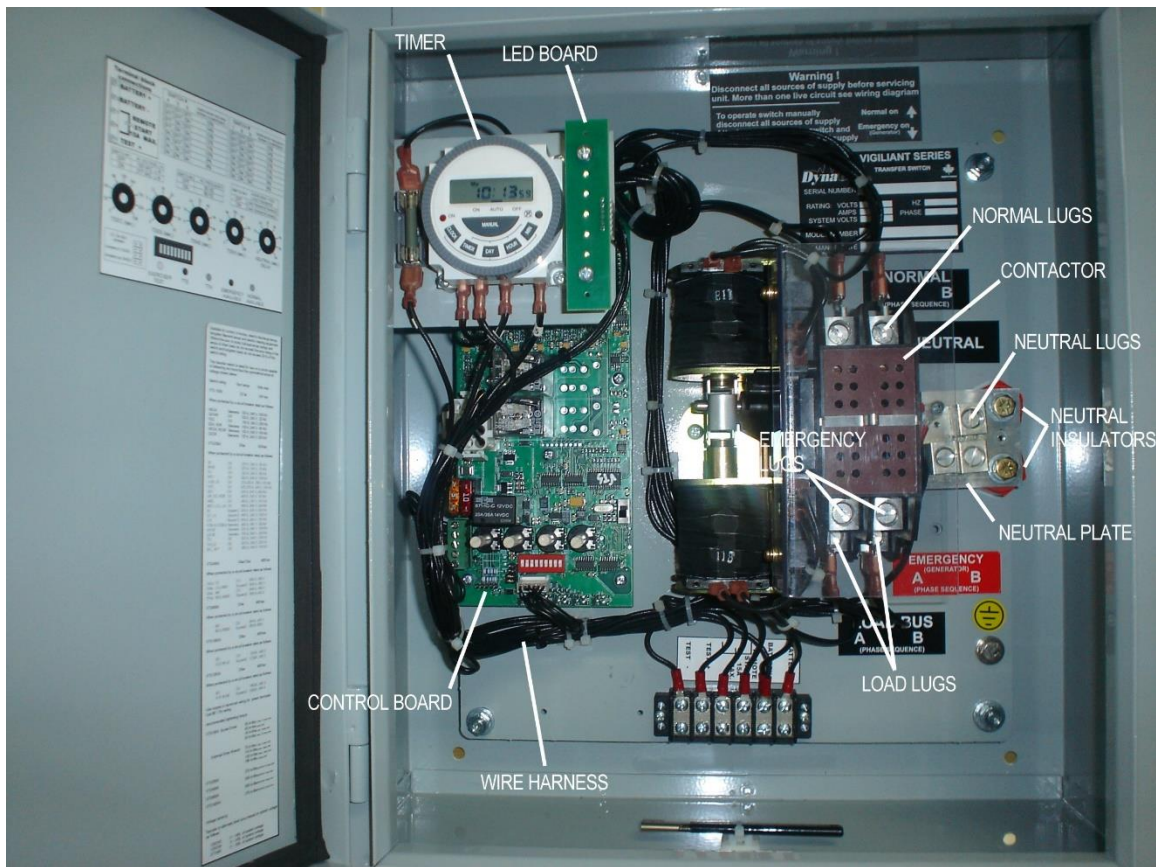

Figure 1. REPLACEMENT PARTS

TO REPLACE THE CONTROL BOARD

First, make certain that the switch is disconnected from all power and control sources.

Undo the front cover screws, or open the door depending on the enclosure style.

The timer support bracket will have to be removed first to allow full access to the control board. Use a 3/8" nut driver to remove the two sets of #10 nuts and washers holding the timer support bracket to the side of the enclosure. Figure 2. The bracket assembly can now be gently moved aside to allow access to the control board screws.

Unplug all the connections to the control board. The green 5-pin connector pulls straight out. The white 9 and 12-pin connectors pull straight out by gripping the connectors such that the top and bottom locking clips on each connector are released by this action. Disconnect the 6-pin connector at the bottom of the control board.

Remove seven screws securing the control board to the inner panel. Figure 3.



Figure 2. REMOVING THE TIMER SUPPORT BRACKET

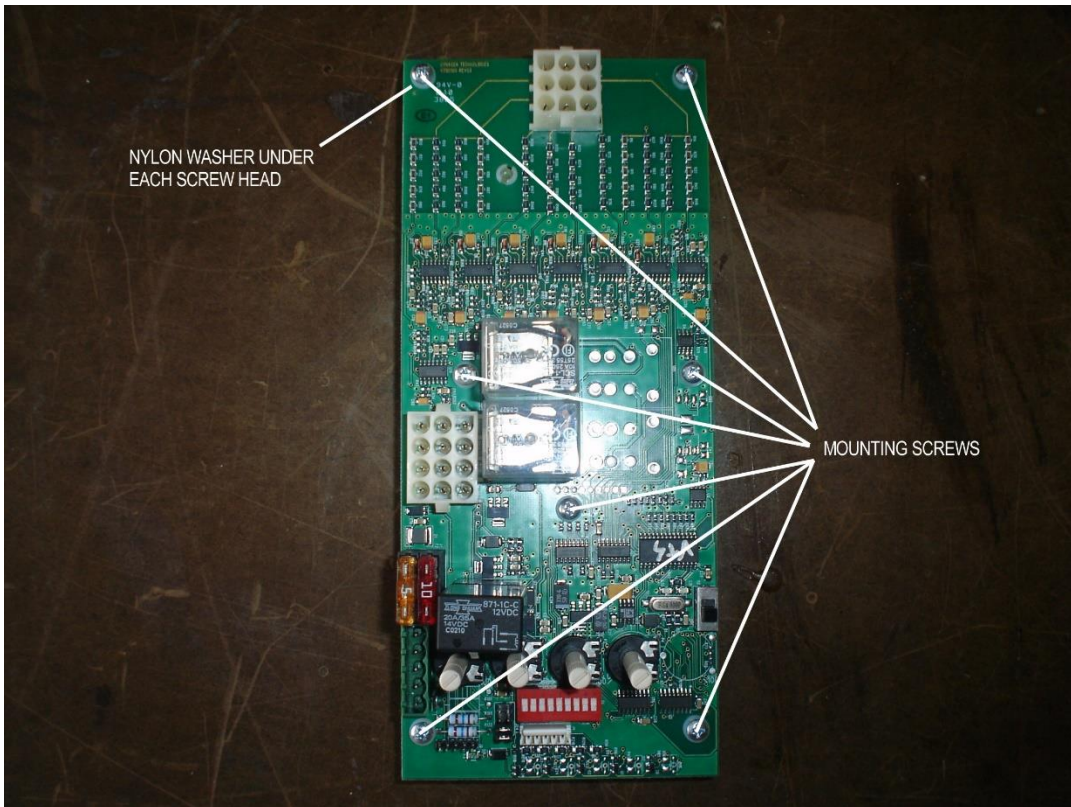

Figure 3. CONTROL BOARD MOUNTING SCREW LOCATIONS

The control board can now be removed from the inner panel.
Remove each screw, spacer and nylon washer from the old board, and replace in the new board. Do not forget the single self retaining nylon spacer. Figure 4.

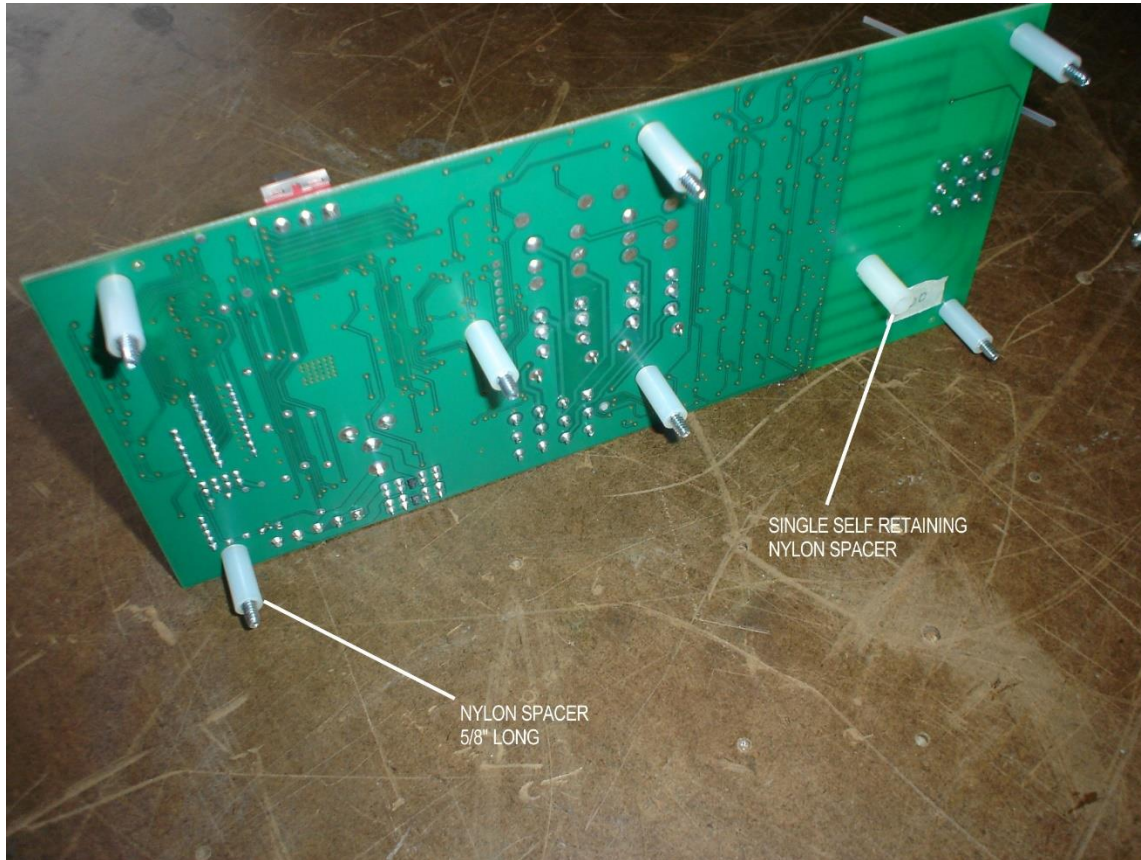

Figure 4. CONTROL BOARD NYLON SPACERS

The replacement control board can now be installed by following this procedure in the reverse order. Note the orientation of the control board when installing. The white 9-pin socket is at the top. Align the control board with the mounting holes. Tighten the screws evenly to avoid undue stress on the circuit board. Tighten to 5in-lb max. Replace the timer support bracket. Tighten the nuts to 25in-lb.

TO REPLACE THE SWITCH UNIT

First, make certain that the switch is disconnected from all power and control sources.

Undo the front cover screws, or open the door depending on the enclosure style.

Unfasten, but do not remove two screws securing the transparent switch cover. Figure 5.

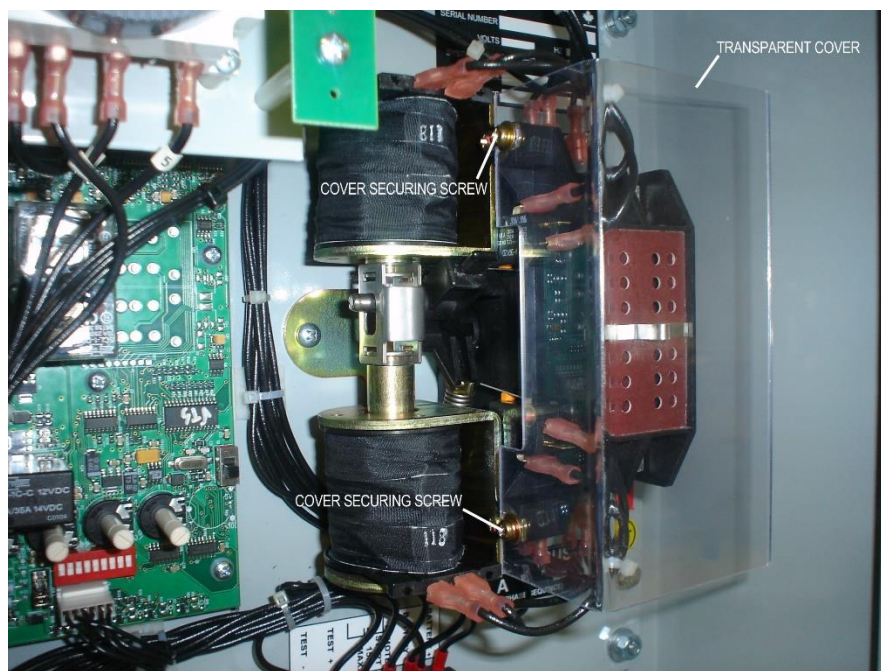

Figure 5. TRANSPARENT COVER SECURING SCREWS

The cover has slots which fit over the screws, so it is not necessary to completely remove them in order to remove the cover. The switch cover can now be lifted clear.

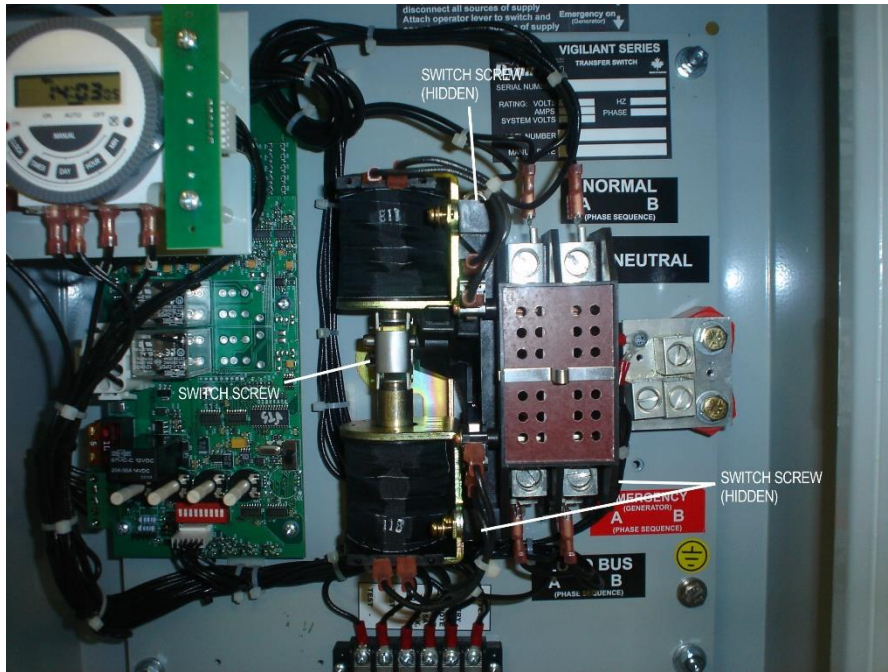

Figure 6. SWITCH SECURING SCREWS

Disconnect all the power and control wiring connections to the switch. Carefully withdraw the power cables from the switch terminals.

Remove four screws securing the switch unit to the inner panel. The switch unit can now be removed from the inner panel. Figure 6.

Follow this procedure in the reverse order to install a replacement switch unit. Do not exceed 25in-lb torque when replacing the switch screws.

Confirm all wiring connections by consulting the wiring diagram. The individual wires are identified at each end. Note the wire connections to the two limit switches shown in figure 7.

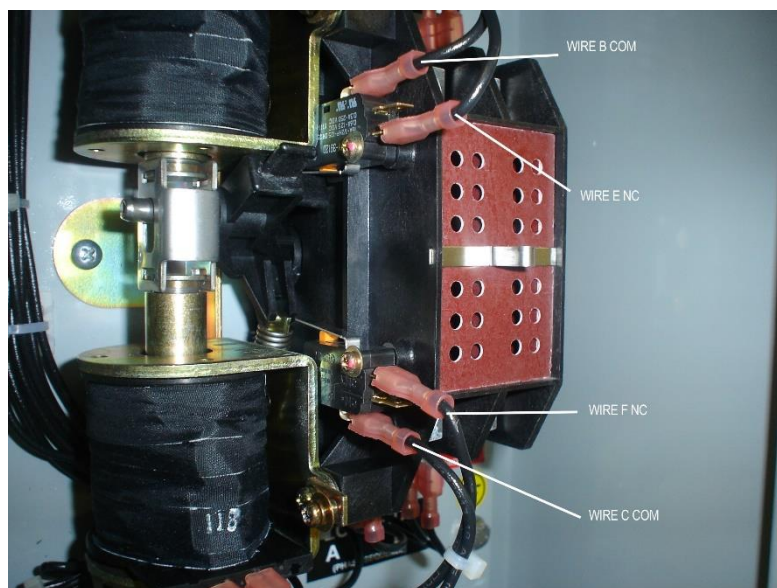

Figure 7. LIMIT SWITCH CONNECTIONS

TO REPLACE THE SWITCH LUGS

Remove the switch as described above.

All the lug securing screws can be accessed from the underside of the switch unit. Figure 8. Use a #2 Phillips screwdriver to detach the lugs and spade terminal adaptors.

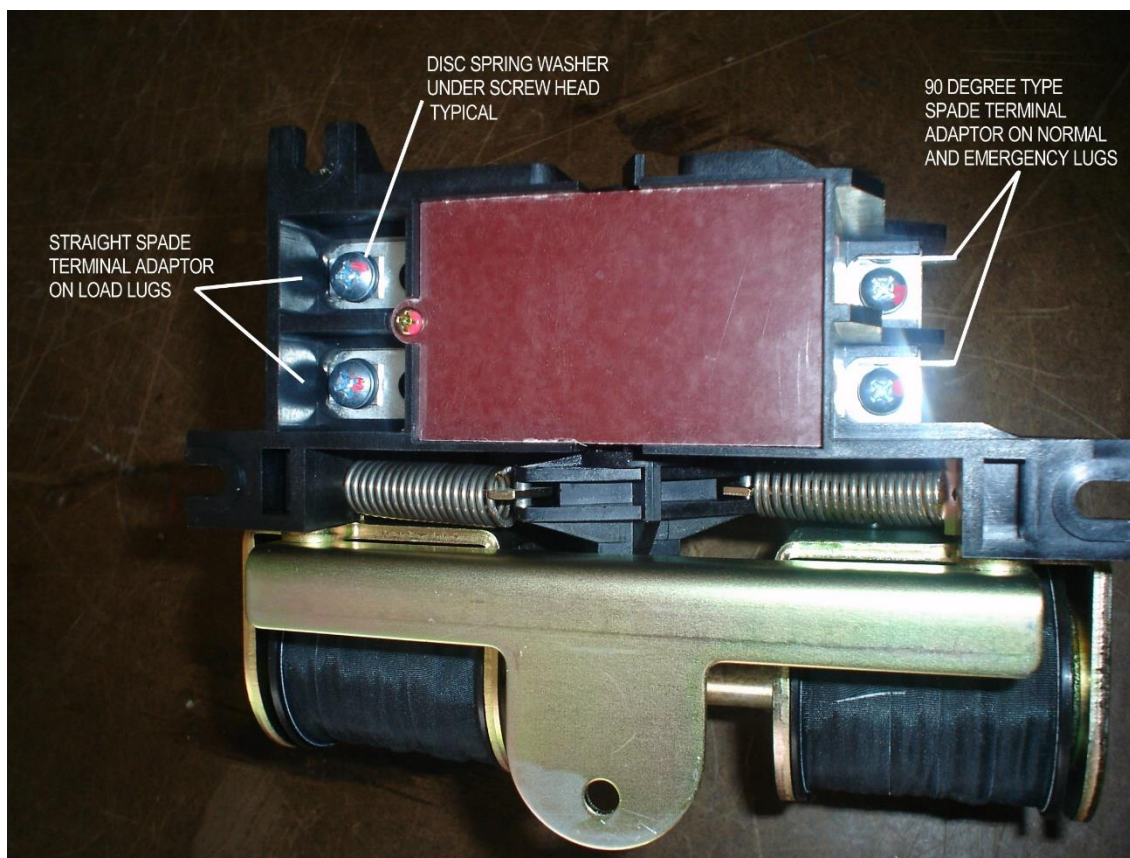

Figure 8. UNDERSIDE OF SWITCH SHOWING TERMINAL MOUNTING SCREWS

Re-assemble using the same hardware. The disc spring washer is assembled under the head of the screw, then the spade terminal adaptor. The end of the screw is then passed through the switch strap and screwed into the terminal lug. Note that the straight spade terminal adaptor is only used at the load lug locations. The normal and emergency spade terminal adaptors are the 90 degree type. Torque all the lug securing screws to 26 in-lb.

TO REPLACE THE TIMER UNIT

First, make certain that the switch is disconnected from all power and control sources.

Undo the front cover screws, or open the door depending on the enclosure style.

Disconnect the timer wiring.

Remove four screws securing the timer to the support bracket and lift the timer off. Figure 9.

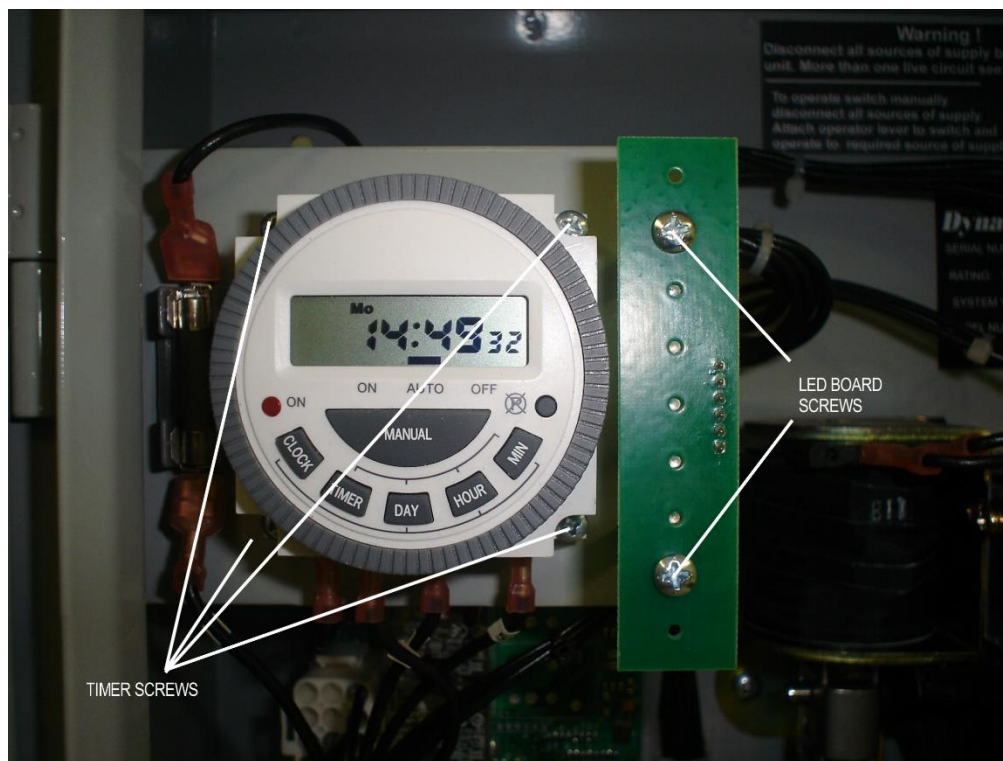

Figure 9. TIMER AND LED BOARD SCREWS

Re-use the four screws and spacers.

Follow this procedure in the reverse order to install a replacement timer unit. Do not exceed 5in-lb torque when replacing the timer screws.

TO REPLACE THE LED BOARD

First, make certain that the switch is disconnected from all power and control sources.

Undo the front cover screws, or open the door depending on the enclosure style.

Unplug the LED board wire connector.

Remove two screws securing the LED board to the support bracket and lift the LED board off. Figure 9.

Re-use the two screws and spacers. Note that one 5/8" and one 1" long spacer are used on each screw.

Follow this procedure in the reverse order to install a replacement LED board. Do not exceed 5in-lb torque when replacing the LED board screws.

Note the orientation of the replacement board. The wire connector is on the right hand side.

TO REPLACE THE WIRING HARNESS

The replacement wiring harness is supplied as a complete unit, pre-formed as far as possible thus permitting a virtual "drop in" installation once the original harness is removed.

First, make certain that the switch is disconnected from all power and control sources.

Undo the front cover screws, or open the door depending on the enclosure style.

Disconnect the white 9 and 12-pin connectors from the control board. Pull them straight out by gripping the connectors such that the top and bottom locking clips on each connector are released by this action.

Disconnect the 6-pin connector at the bottom of the control board. Disconnect the green 5-pin connector from the control board.

Pull all the spade terminal connectors from both the switch unit and the timer. Remove the 6-pin connector from the LED board.

Disconnect all the wires from the 6-position terminal block and neutral block. Figure 10.

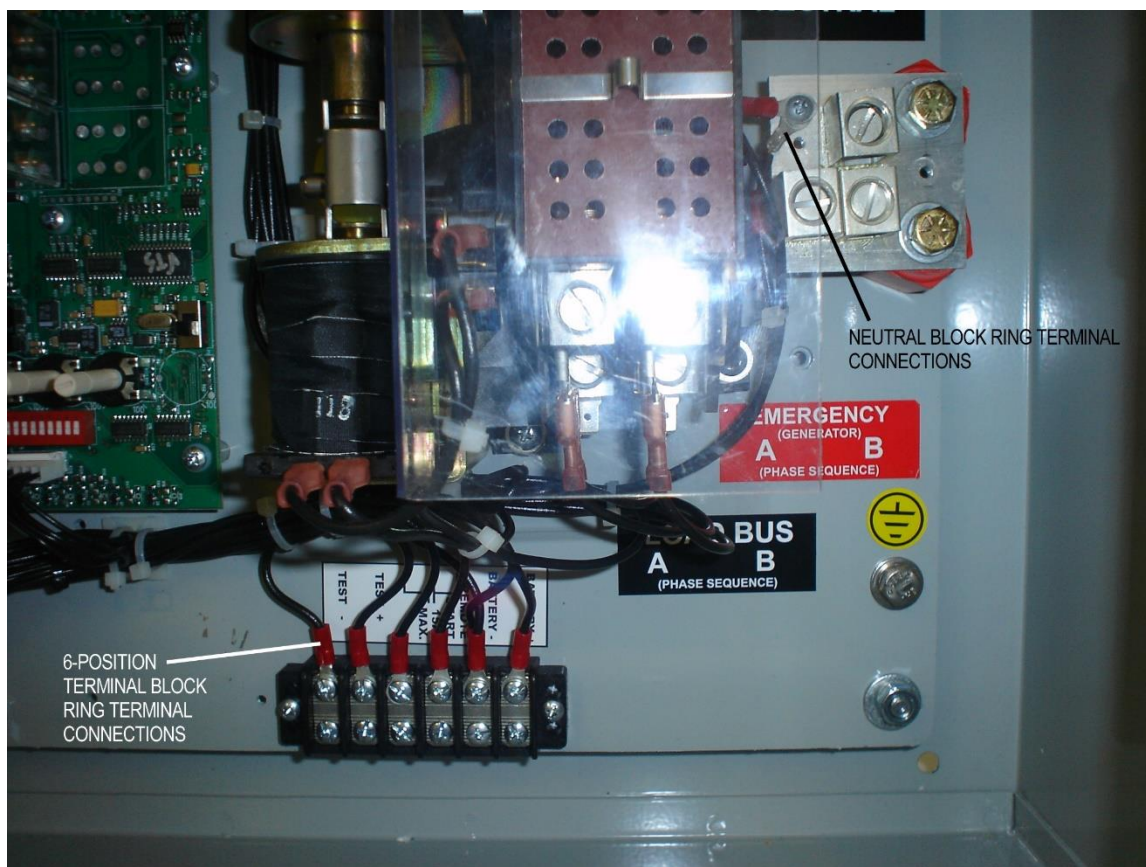

Figure 10. WIRE HARNESS 6-POSITION TERMINAL BLOCK and NEUTRAL CONNECTIONS

Use wire cutters to sever the nylon wire ties to release the original harness at the tie rap base locations.

Note the general layout of the original harness before lifting it clear.

Install the replacement harness with reference to the wiring diagram for the wire terminations. Each wire is identified with a letter on both ends. Check the installation and replace the nylon tie raps to secure the harness.

TO REPLACE THE NEUTRAL PLATE ASSEMBLY

First, disconnect the wires attached to the neutral plate. The neutral plate is secured to the supporting insulators by two ¼"-20 x ½" long hexagon screws, flat washers and spring lockwashers. Figure 11. By removing these screws the neutral plate assembly may be detached from the insulators. Be sure to grip the insulators with a suitable tool to prevent them from rotating when removing the hexagon screws. Tighten the screws to 40 in-lb. when re-assembling, again holding the insulators to prevent them from rotating.

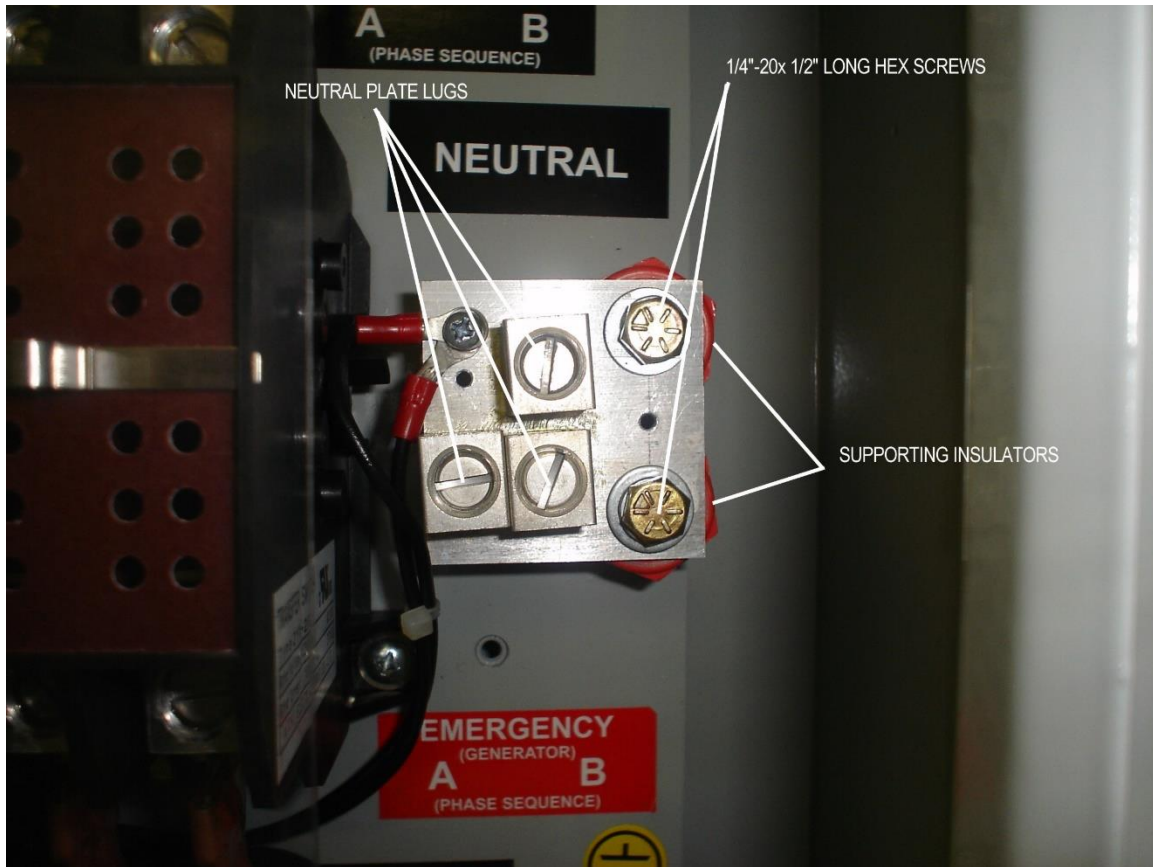

Figure 11. NEUTRAL PLATE ASSEMBLY

TO REPLACE THE NEUTRAL PLATE LUGS Figure 11

First remove the neutral plate. The screws securing the lugs are #10-32 x 5/16" long. These thread into the lug, from the reverse side of the neutral plate with a flat washer against the plate and a spring lockwasher under the head of the screw. Apply an oxide inhibitor to the lug/plate surfaces. Tighten the screws securing the lugs to 26 in-lb.

SERVICE NOTES-200A VIGILANT ATS 1000 and 2000 series

CONTENTS

PAGE

Replacement Parts Identification. _____	41
Wiring Diagram and Wiring Harness Identification. _____	41

Control Board Replacement.	41
Switch unit Replacement.	43
Switch Lug Replacement.	45
Timer Replacement.	46
LED Board Replacement.	46
Wiring Harness Replacement.	47
Neutral Plate Replacement.	47
Neutral Plate Lugs Replacement.	48

REPLACEMENT PARTS Figure 1.

The listing below identifies replacement parts. Order by using the description and stock code number. In addition, provide the serial number of the transfer switch in question.

<u>Description</u>	<u>Stock Code Number</u>
200A Contactor	SWT0068
Control Board 12v relay. 240v working. no neutral delay.	VTSC100-240-12-X
Control Board 24v relay. 240v working. no neutral delay.	VTSC100-240-24-X
200A Contactor and Neutral Lugs	CON0124
200A Neutral Plate	DWG1186R2
200A Neutral Insulator	INN0001
Timer (2000 series only)	ACC0073
LED Board (2000 series only)	VTS-ANNL
12v dc Relay (1000) series only)	RLY0032

WIRING DIAGRAMS and WIRE HARNESS

<u>Vigilant Switch Model</u>	<u>Wiring Diagram</u>	<u>Wire Harness</u>
VTS2-0200-2-240-X	1259R5	1267R5
VTS1-0200-2-240-X	1212R1	1272R1

It is recommended that after completing any of the following procedures, a test be performed to verify the proper operation of the transfer switch.



WARNING: When replacing any parts of the mechanism, isolate the transfer switch from all possible sources of power.

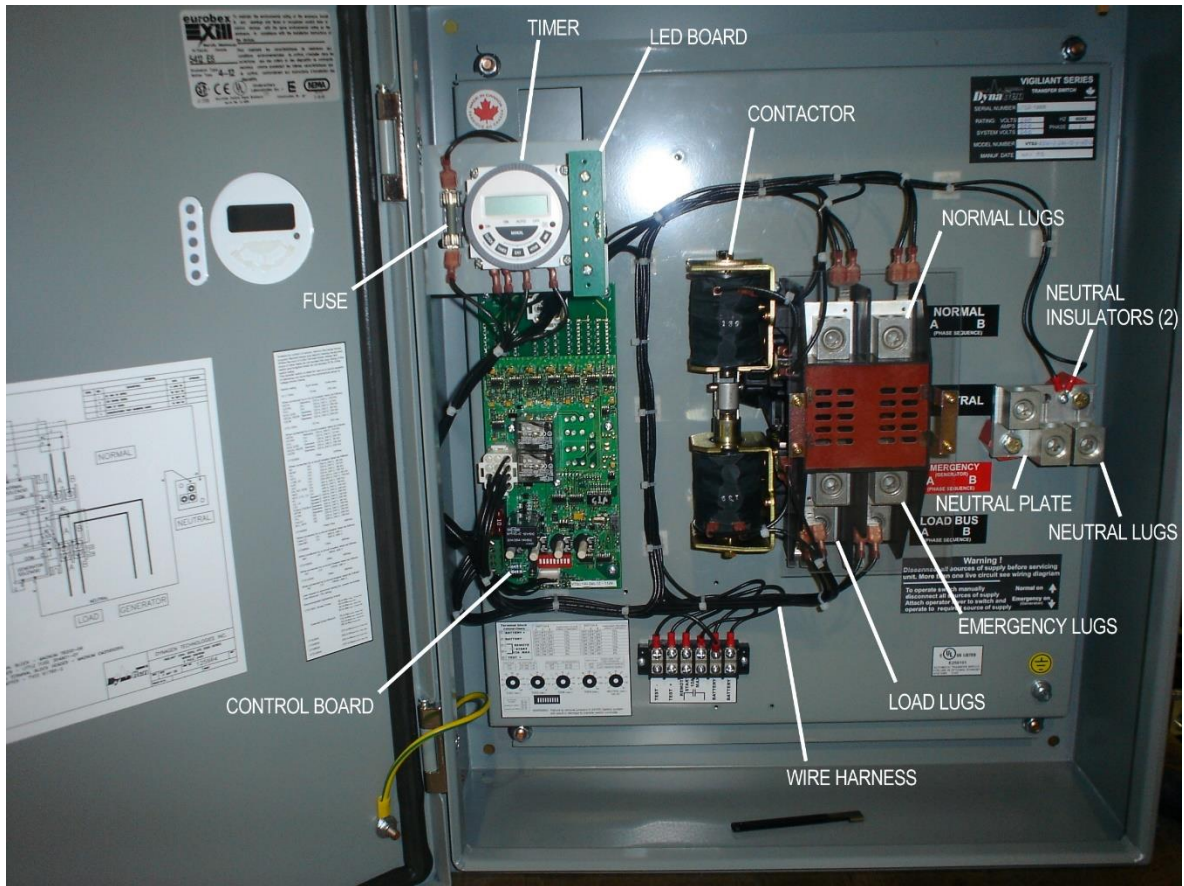

Figure 1. REPLACEMENT PARTS

TO REPLACE THE CONTROL BOARD

Unplug all the connections to the control board. The green 5-pin connector pulls straight out. The white 9 and 12-pin connectors pull straight out by gripping the connectors such that the top and bottom locking clips on each connector are released by this action. Disconnect the 6-pin connector at the bottom of the control board.

Remove seven screws securing the control board to the inner panel. Figure 2.

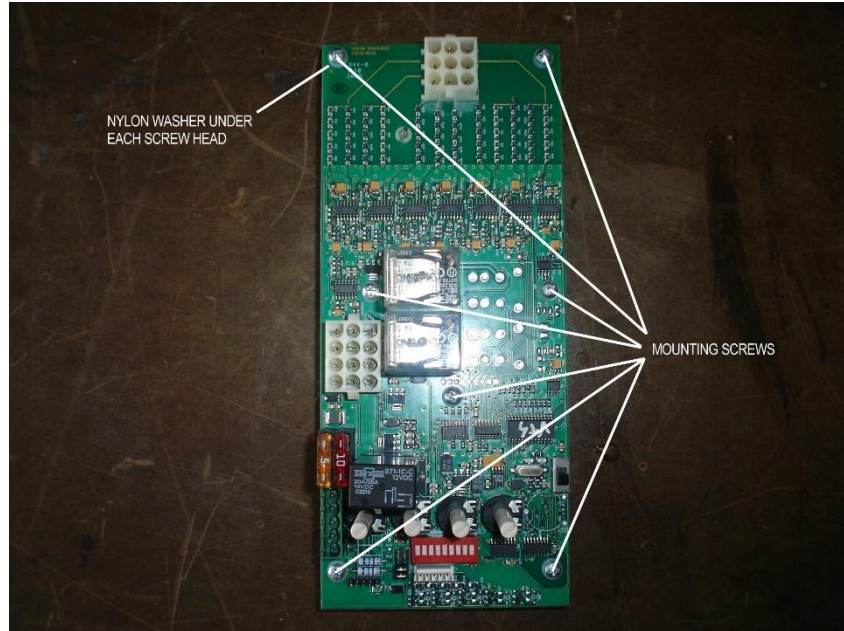

Figure 2. CONTROL BOARD MOUNTING SCREW LOCATIONS

The control board can now be removed from the inner panel. Remove each screw, spacer and nylon washer from the old board, and replace in the new board. Do not forget the single self retaining nylon spacer. Figure 3.

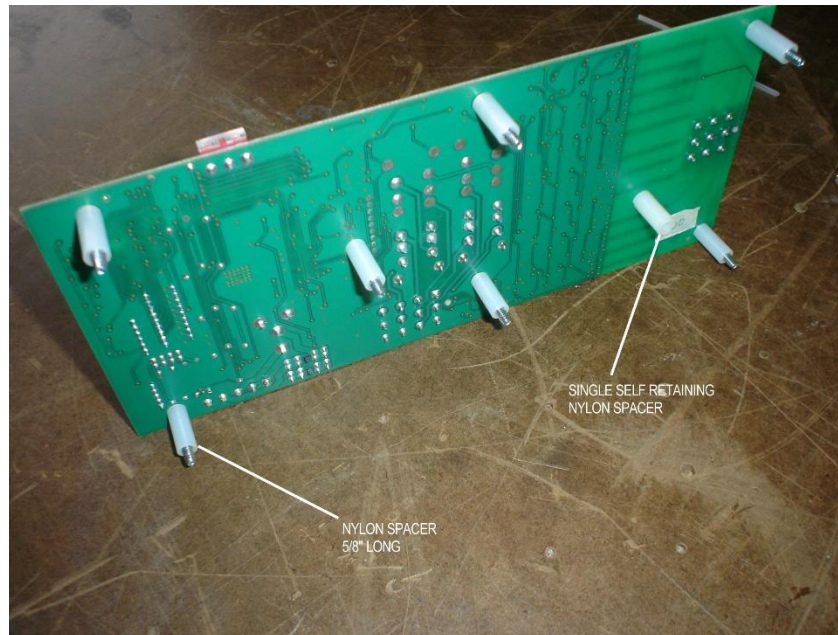

Figure 3. CONTROL BOARD NYLON SPACERS

The replacement control board can now be installed by following this procedure in the reverse order. Note the orientation of the control board when installing. The white 9-pin socket is at the top. Align the control board with the mounting holes. Tighten the screws evenly to avoid undue stress on the circuit board. Tighten to 5in-lb max.

TO REPLACE THE SWITCH UNIT

First, make certain that the switch is disconnected from all power and control sources.

Undo the front cover screws, or open the door depending on the enclosure style.

Remove the transparent switch cover by gripping the two long sides and gently pressing down in the center of the cover with thumbs. This will allow the cover retaining bracket tongues to be withdrawn from the slots in the switch housing. Figure 4.

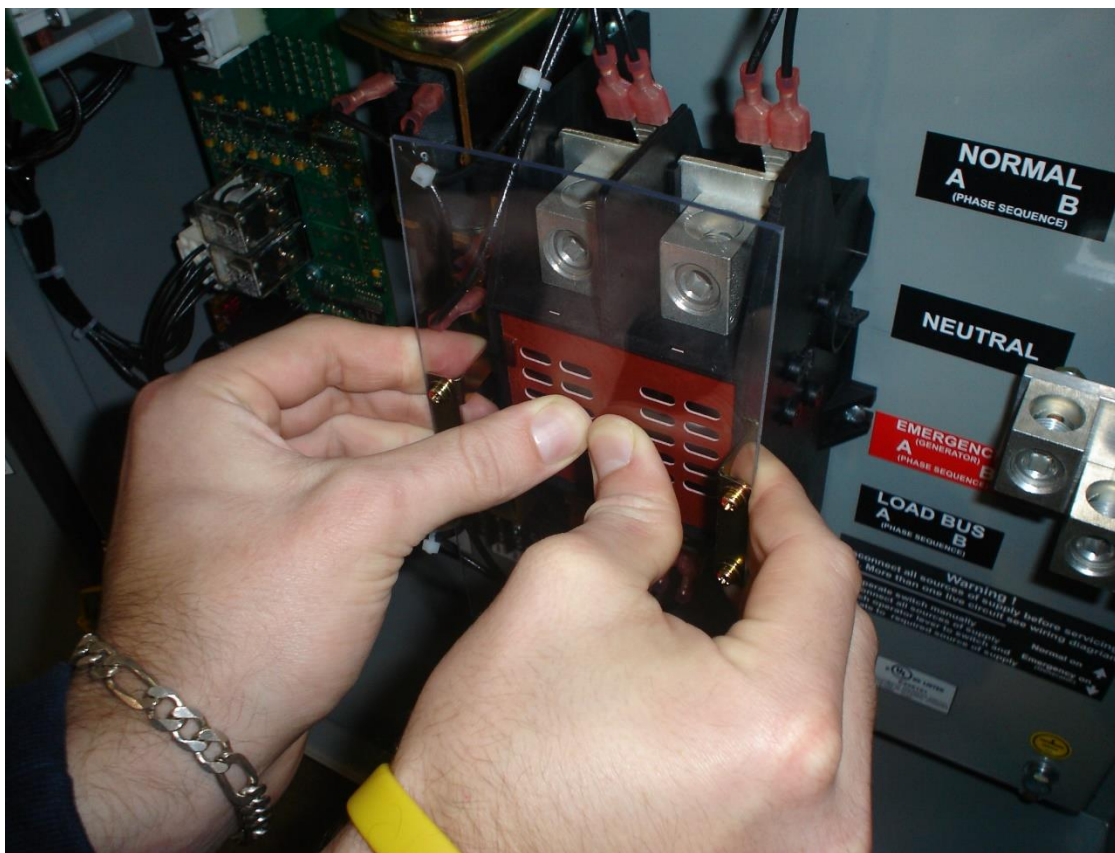

Figure 4. TRANSPARENT COVER REMOVAL

Disconnect all the power and control wiring connections to the switch. Carefully withdraw the power cables from the switch terminals.

Remove four screws securing the switch unit to the inner panel. The switch unit can now be removed from the inner panel.

Follow this procedure in the reverse order to install a replacement switch unit. Do not exceed 25in-lb torque when replacing the switch screws.

Confirm all wiring connections by consulting the wiring diagram. The individual wires are identified at each end. Note the wire connections to the two limit switches shown in figure 5.

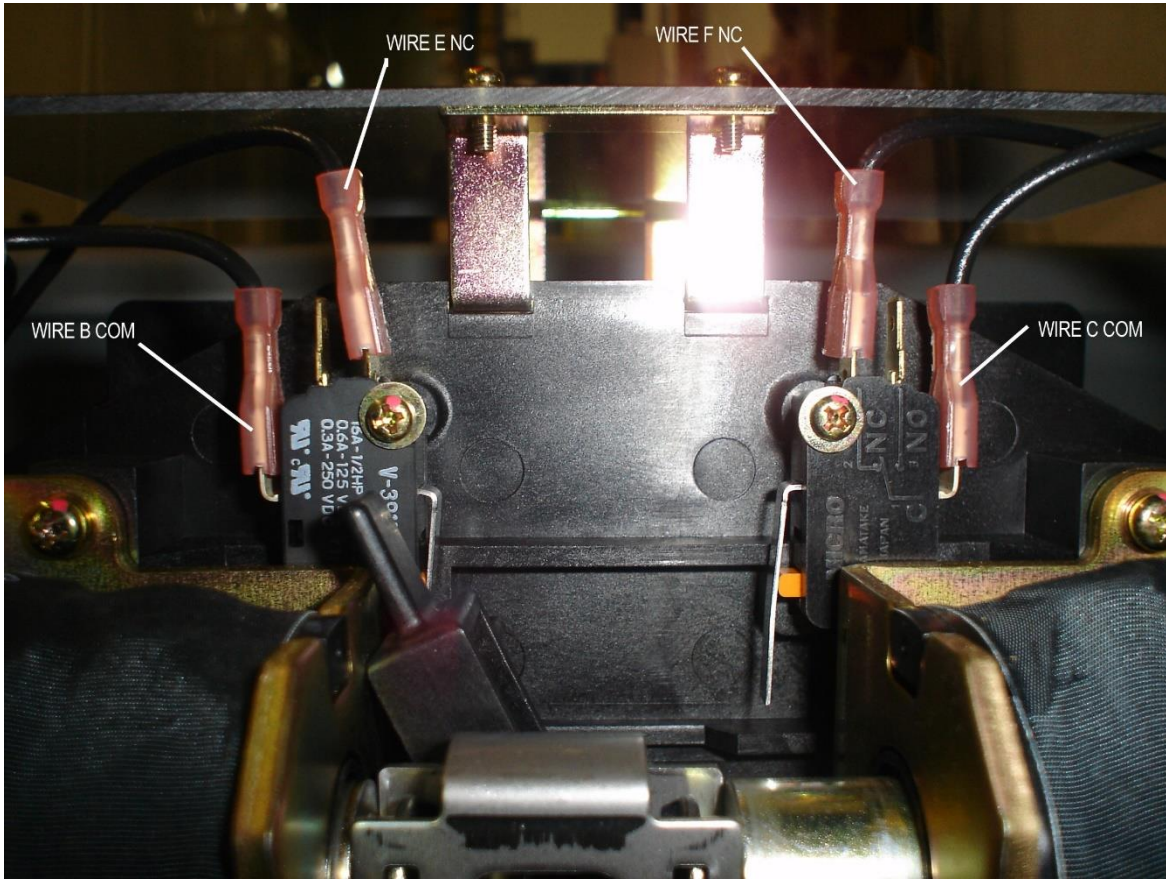

Figure 5. LIMIT SWITCH CONNECTIONS

TO REPLACE THE SWITCH LUGS

Remove the switch as described above.

The normal lugs may be removed directly from the switch with a 7/16" socket. Figure 6.

To remove the load lugs, the load adaptor plates have to be removed first. Figure 7. Use a #2 Phillips screwdriver to remove the two screws in each switch strap, which will allow the lug adaptor plate to be slid out of the switch housing. The switch lug can now be removed from the adaptor plate with a 7/16" socket. The emergency lugs can now be removed directly from the switch with a 7/16" socket. Follow this procedure in reverse to reassemble. Note that the screws securing the lugs use a disc spring washer under the head of the screw, then a flat washer. Tighten these lug screws to 60in-lb. The load adaptor plates screws use a spring lockwasher under the head of the screw, then a flat washer. These screws should also be torqued to 29.5in-lb.

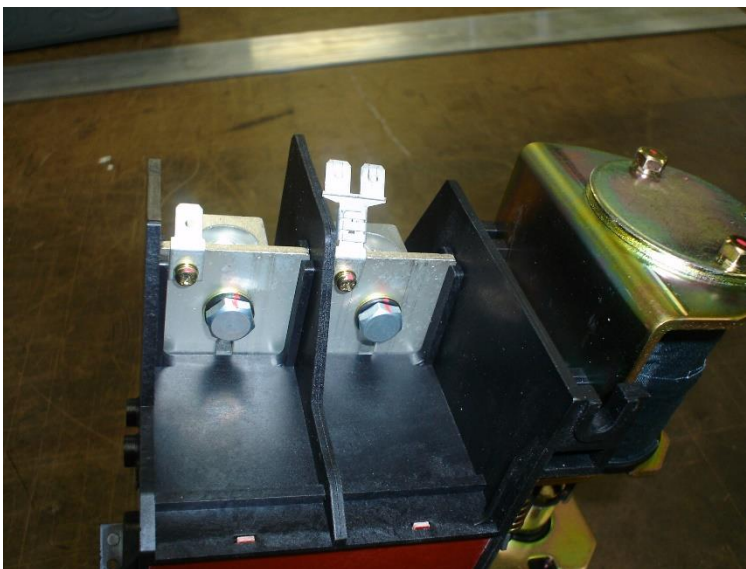

Figure 6. UNDERSIDE OF SWITCH SHOWING THE NORMAL LUG MOUNTING SCREWS

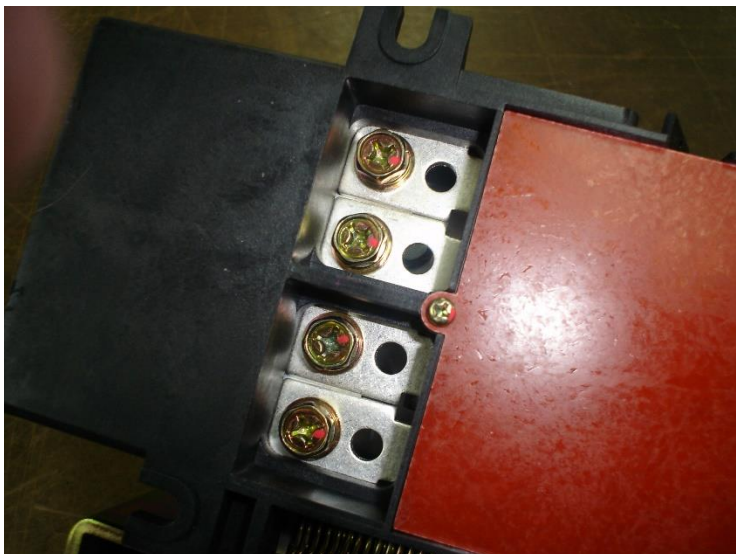

Figure 7. UNDERSIDE OF SWITCH SHOWING THE LOAD LUG ADAPTOR PLATE SCREWS

TO REPLACE THE TIMER UNIT

First, make certain that the switch is disconnected from all power and control sources.

Undo the front cover screws, or open the door depending on the enclosure style.

Disconnect the timer wiring.

Remove four screws securing the timer to the support bracket and lift the timer off. Figure 8.

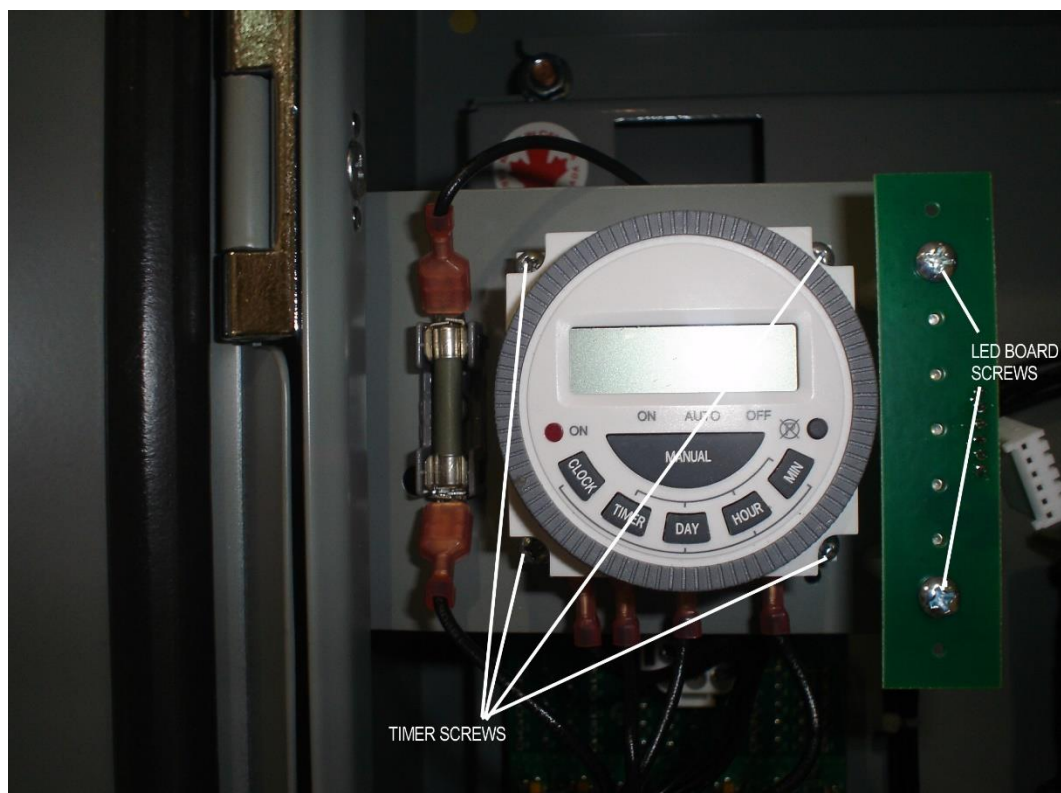

Figure 8. TIMER AND LED BOARD SCREWS

Re-use the four screws and spacers.

Follow this procedure in the reverse order to install a replacement timer unit. Do not exceed 5in-lb torque when replacing the timer screws.

TO REPLACE THE LED BOARD

First, make certain that the switch is disconnected from all power and control sources.

Undo the front cover screws, or open the door depending on the enclosure style.

Unplug the LED board wire connector.

Remove two screws securing the LED board to the support bracket and lift the LED board off. Figure 8.

Re-use the two screws and spacers. Note that one 5/8" and one 1" long spacer are used on each screw.

Follow this procedure in the reverse order to install a replacement LED board. Do not exceed 5in-lb torque when replacing the LED board screws.

Note the orientation of the replacement board. The wire connector is on the right hand side.

TO REPLACE THE WIRING HARNESS

The replacement wiring harness is supplied as a complete unit, pre-formed as far as possible thus permitting a virtual “drop in” installation once the original harness is removed.

First, make certain that the switch is disconnected from all power and control sources.

Undo the front cover screws, or open the door depending on the enclosure style.

Disconnect the white 9 and 12-pin connectors from the control board. Pull them straight out by gripping the connectors such that the top and bottom locking clips on each connector are released by this action.

Disconnect the 6-pin connector at the bottom of the control board. Disconnect the green 5-pin connector from the control board.

Pull all the spade terminal connectors from both the switch unit and the timer. Remove the 6-pin connector from the LED board.

Disconnect all the wires from the 6-position terminal block and neutral block.

Use wire cutters to sever the nylon wire ties to release the original harness at the tie rap base locations.

Note the general layout of the original harness before lifting it clear.

Install the replacement harness with reference to the wiring diagram for the wire terminations. Each wire is identified with a letter on both ends. Check the installation and replace the nylon tie raps to secure the harness.

TO REPLACE THE NEUTRAL PLATE ASSEMBLY

First, disconnect the wires attached to the neutral plate. The neutral plate is secured to the supporting insulators by two 1/4”-20 x 5/8” long hex screws, flat washers and spring lockwashers. Figure 9. By removing these screws the neutral plate assembly may be detached from the insulators. Be sure to grip the insulators with a suitable tool to prevent them from rotating when removing the hexagon screws. Tighten the screws to 40 in-lb. when re-assembling, again holding the insulators to prevent them from rotating.

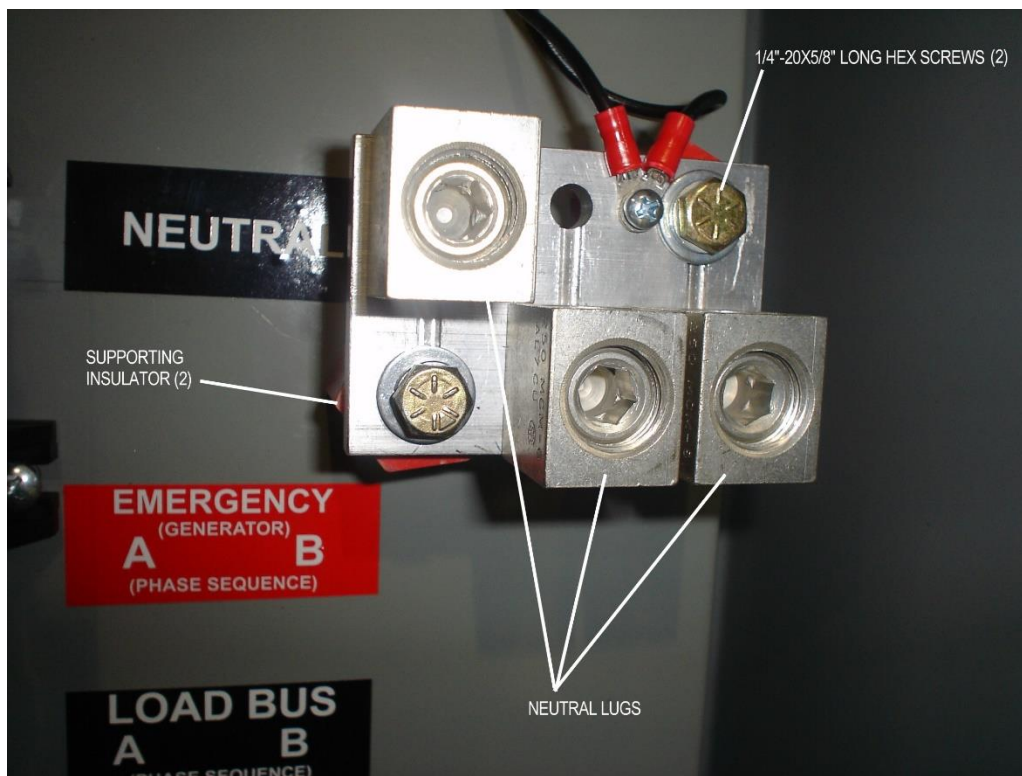

Figure 9. NEUTRAL PLATE ASSEMBLY

TO REPLACE THE NEUTRAL PLATE LUGS

First remove the neutral plate. The screws securing the lugs are 1/4"-20 x 5/8" long. These thread into the lug, from the reverse side of the neutral plate with two flat washers against the plate and a spring lockwasher under the head of the screw. It is important that two flat washers are used to prevent undue penetration of the screw into the wire lug. Apply an oxide inhibitor to the lug/plate surfaces. Tighten the screws securing the lugs to 60 in-lb.