

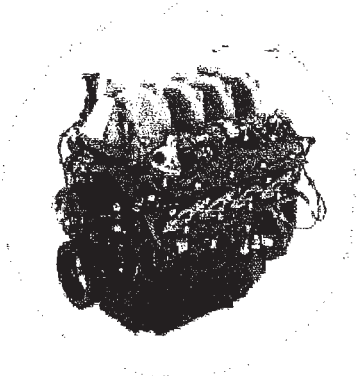

POWER SOLUTIONS, INC.

OPERATION AND MAINTENANCE MANUAL

CERTIFIED STATIONARY PRODUCT



VORTEC 8100 V8

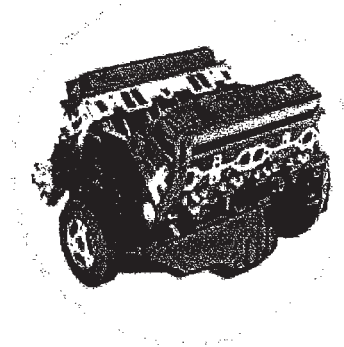

VORTEC 5000 V8

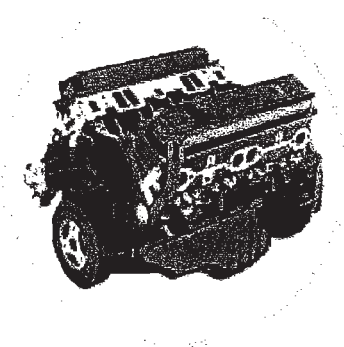

VORTEC 5700 V8

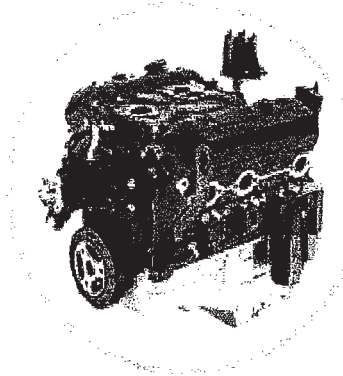

VORTEC 4300 V6

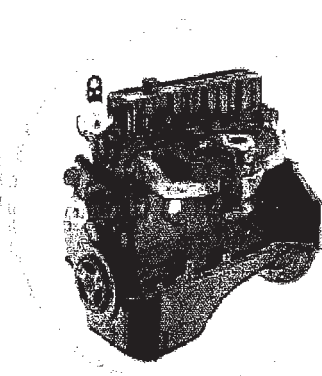

3.0L L4

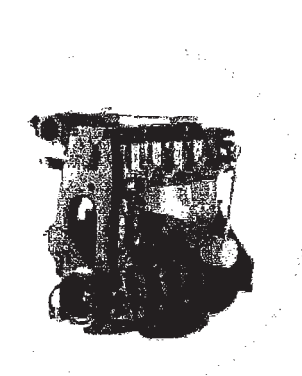

1.6L L4

Industrial Gasoline & Alternative Fueled Engines

A product by Power Solutions, Inc
Wood Dale, IL

36100014 -REV 1/2009

Table of Contents

TOPIC	PAGE
Introduction	4
How to Use This Manual	4
Engine Identification	4
Parts and Service	5
Service Literature	5
Operating Instructions	5
Fuel Systems	5
Governors	5
Oil Pressure Gauge	5
Temperature Gauge	6
Voltmeter	6
Tachometer/Hourmeter	6
Starting the Engine	6
LPG or NG Fuel Systems	7
Stopping the Engine	7
Fuel Recommendations	7
Fuel Quality	7
Spark Plugs	8
Power Loss at Higher Elevations	8
Maintenance Instructions	8
Initial Start Up Maintenance	8
Routine Maintenance	8
Scheduled Preventive Maintenance	8
Engine Oil Level Check	9
Adding Engine Oil	9
Changing Engine Oil and Filter	9

TOPIC	PAGE
Engine Oil Quality	9
Engine Oil Recommendation	10
Oil Filter	10
Engine Air Cleaner	10
Safety Element	11
Cooling System	11
Coolant Level	11
Radiator	12
Fan Belts	12
Serpentine Belt	12
V-Type Belt	12
Fuel Filter	12
Fuel Shut Off	13
Ignition Systems	13
Types of Ignition Systems	13
Ignition Timing	13
Spark Plugs	13
Storage	14
One to Six Months	14
Extended Periods	14
Removing the Engine From Storage	14
Maintenance Schedule	15
General Specifications	16

No part of this publication may be reproduced without written permission from Power Solutions, Inc. At the time of publication, all of the information included in this publication is accurate to the best of our knowledge. Power Solutions, Inc. cannot be responsible for information that has changed after this book was published.

Introduction

Power Solutions, Inc. is pleased that you have selected our engine for your requirements. Power Solutions, Inc. takes great pride in our tradition of quality products produced from our line of industrial gasoline and alternative fuel engines.

Prior to starting the engine at your facility, certain checks should be made. Please read the Initial Start-Up inspection requirements in the Maintenance Section of this manual. If you have further questions please contact your PSI account representative or Customer Support Engineer

How to Use this Manual

This manual contains instructions on the safe operation and preventive maintenance of your PSI industrial engine. We urge you to read this manual prior to start up or operation of the engine.

The Table of Contents permits you to quickly open the manual to any section.

Power Solutions, Inc., engines are built with a variety of standard and/or optional components to suit a broad range of customer requirements. This manual does not identify equipment as standard or optional. All the equipment described in this manual may not be found on your engine or power unit.

Please pay special attention to the NOTES, CAUTIONS, and WARNINGS. WARNINGS remind you to be careful in areas where carelessness can cause personal injury. CAUTIONS are given to prevent you from error that could cause damage to the equipment. NOTES give you added information designed to help you.

The descriptions and specifications contained in this manual were in effect at the time of publication. Power Solutions, Inc. reserves the right to discontinue models at any time, or to change specifications or design without notice and without incurring obligation.

Engine Identification

An identification label is affixed to the right side of the engine on the rocker cover when looking at the engine from the flywheel end.. (The engine serial number is also stamped into the left side of the cylinder block near the engine flywheel.) The label contains the engine family number and a serial number which identifies the engine from other PSI engines. The engine model and serial number are required when seeking information concerning the engine and/or ordering replacement service parts.

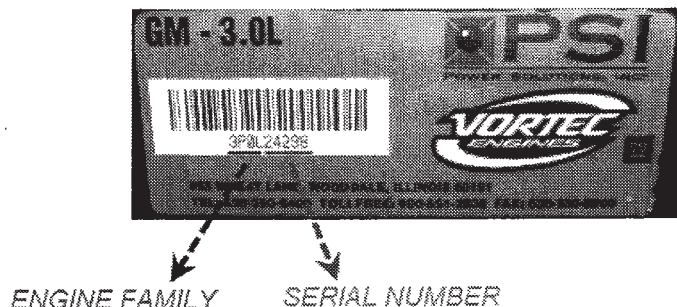

Parts and Service

Replacement parts can be obtained from Power Solutions, Inc. by calling the Aftermarket Parts Department at 888-331-5769. The engine model and serial number will be required when seeking information and/or ordering parts.

Service and technical support for PSI engines can be obtained by contacting the Service Department at 888-331-5764 or via email at service@powergreatlakes.com.

Service Literature

Additional operator manuals and service manuals for specific PSI engines can be obtained by contacting the Parts or Service Department at 888-331-5769.

Operating Instructions

Fuel Systems

The fuel system installed on your engine operates with an Integrated Electronic Pressure Regulator (IEPR) and a diaphragm style variable venturi mixer. The IEPR will regulate the fuel pressure being delivered to the mixer; these parts are not adjustable and should not be tampered with. Proper inlet fuel pressure is critical to the proper operation of the fuel system and engine; you should review the pressure, volume, and BTU recommendations prior to commissioning the engine.

Governors

PSI engines have an isochronous governor installed. The governor controls the movement of the throttle plate via a 0-12 volt signal and a ground provided by the Engine Control Module. The throttle plate allows the correct amount of air to enter the engine; this movement is monitored by using 2 throttle position sensors located internal to the governor. The ECM monitors various engine sensors to determine what the correct throttle position should be.

Oil Pressure Reading

The oil pressure reading shows the engine lubrication system pressure in pounds per square inch (psi) and should be checked frequently to ensure that the system is functioning correctly. Should the pressure fluctuate or drop, stop the engine and find the cause. Do not operate the engine at lower than normal oil pressure (see maintenance schedule for minimum engine oil pressure).

CAUTION: Do not continue to operate your engine below the normal operating range. Severe engine damage could occur.

Temperature Reading

The coolant temperature reading will indicate overheating which may arise from low coolant level, plugged radiator, loose fan belt or faulty thermostat. Coolant level should be checked daily.

CAUTION: If the engine continues to overheat, have the cooling system checked and serviced.

Voltage Reading

The voltage reading indicates the battery charging voltage. If the meter consistently indicates less than 13 volts or more than 15.7 volts under normal operating conditions, you should have the engine electrical system checked by a qualified service technician.

Tachometer/Hourmeter

The tachometer indicates the engine speed in hundreds of revolutions per minute (rpm). It serves, as a guide to insure that engine speed is set correctly.

The hour meter records the hours of operation and is used to determine when periodic maintenance is required.

Starting the Engine

Warning: All internal combustion engines give off various fumes and gases while running. Do not start or run the engine in a closed or poorly ventilated building where exhaust gases can accumulate. Avoid breathing these gases as they may contain poisonous carbon monoxide, which can endanger your health or life if inhaled steadily for even a few minutes.

If the engine is equipped with a manual clutch it must be disengaged prior to starting the engine. Starting the engine with the clutch engaged imposes unnecessary strain on the battery, starter, and driven components.

CAUTION: If the engine stalls or falters during starting, wait 3 to 4 seconds before re-engaging the starter. This will prevent possible damage to the starter or the engine. **DO NOT** operate the starter for periods longer than 30 seconds at a time. An interval of at least 1-minute should be observed between cranking periods to protect the starter from overheating.

LPG or NG Fuel Systems

Turn on the gas supply to the engine. Turn the ignition key to the START position. After the engine starts release the key to the ON position.

Stopping the Engine

Return the engine to idle speed. If the machine is equipped with a clutch, move the clutch lever to the disengaged position. Run engine for a few minutes at idle to allow the coolant system to cool down before turning the ignition switch to the OFF position.

Note: Gasoline fuel injected engines will generally shut off immediately when the key is switched to the off position. When the key is switched off, power to the fuel injector(s), fuel pump and engine control module (ECM) is removed.

Note: LPG engines equipped with a distributorless ignition system (DIS) may run on several seconds after the key is switched to the off position. This may be a normal function of the engine control system running fuel out of the vapor hose to prevent engine backfiring on restart. The engine may run up to 5 seconds after the key is switched to off. Check with the Equipment Manufacture for proper shut down operation.

WARNING: Avoid injury when checking a Hot Engine. Allow the engine to cool down before removing the radiator cap.

CAUTION: Before restarting the engine ensure that both the coolant system and the engine oil level have been checked and re-filled if necessary.

Fuel Recommendations

Fuel Quality

PSI NG engines are designed to operate on pipeline quality natural gas with a heat value of 1050 BTU or higher. LPG engines and fuel systems are designed to operate on HD-5 or HD-10 specification LPG fuel. Fuel other than HD-5 or HD-10 may cause harm to the engine's emission control system and a warranty claim may be denied on this basis if operators can readily find the proper fuel. Use of any other fuel may result in your engine no longer operating in compliance with CARB or EPA emissions requirements.

Spark plugs

Always use the recommended spark plugs for your engine. Hotter or colder plugs, or similar plugs that are not exact equivalents to the recommended plugs, can cause permanent engine damage, reduce the engines useful life, and cause many other problems such as hard starting, spark knock and run-on. Installing new spark plugs regularly is one of the best ways to keep your engine at peak performance.

Power Loss at Higher Elevations

All engines will experience power loss when operated at elevations above sea level, unless they are turbocharged or supercharged. Turbochargers and superchargers are mechanical pumps that put extra air into the engine to make up for the lower air density at higher elevations.

MAINTENANCE INSTRUCTIONS

Initial Start Up Maintenance

The initial start-up checks must be made before putting the engine into service. Please refer to the Maintenance Schedule and perform the initial start-up operations in the sequence shown in column 1.

Routine Maintenance

Routine maintenance provides the best solution for making sure that the engine is ready when you are. The following are some routine service points:

- Make daily checks of the engine oil and coolant levels
- Repair any oil or coolant leaks immediately
- Check battery condition and cables frequently
- Keep the engine air filter clean
- Monitor engine coolant temperature
- Monitor engine oil pressure
- Check voltmeter and charging system

Scheduled Preventive Maintenance

Refer to the Maintenance Schedule to ensure that all of the maintenance items listed are checked and replaced as recommended at the hours shown.

Engine Oil Level Check

The engine oil level should be checked daily. It is recommended that the oil be checked just before the engine is started for the first time for that day. The oil level should be between the 'Add' and the 'Full' marks on the dipstick.

CAUTION: Do not operate the engine with the oil level below the bottom or 'Add' mark on the dipstick, or above the top or 'Full' mark on the dipstick.

Adding Engine Oil

It is normal to add some oil in the period of time between oil changes. The amount will vary with the severity of operation. When adding or replacing engine oil, be sure the oil meets or exceeds the recommended specification.

Changing Engine Oil and Filter

The engine oil and filter must be changed every 150 hours or every 3 months whichever occurs first. Under normal operating conditions, you do not need to change them more often if you use oil and filters of the recommended quality.

The oil and filter should be changed more often if the engine is operating in dusty or extremely dirty areas, or during cold weather. No oil additives or break-in oil change is required.

Engine Oil Quality

To achieve proper engine performance and durability, it is important that you use only engine lubricating oils of the correct quality in your engine. Proper quality oils also provide maximum efficiency for crankcase ventilation systems, which reduces pollution.

Important: use only engine oils displaying the American Petroleum Institute (API) "Starburst" Certification Mark 'FOR GASOLINE ENGINES' on the container.

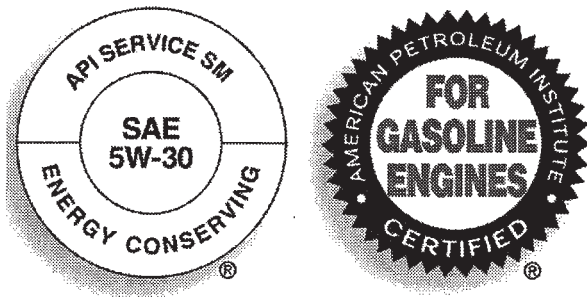

Gasoline engines that are converted for LPG or NG fuels **MUST** use oils labeled 'FOR GASOLINE ENGINES'. Do not use oils that are specifically formulated for Diesel Engines only. CC or CD classifications oils, even when labeled Heavy Duty or for Natural Gas Engines, **ARE NOT ACCEPTABLE**.

Engine Oil Recommendation

Multi-viscosity oils are recommended. SAE 10W-30 is recommended for your engine from 0 degrees F (-18 degrees C) or above. If ambient temperatures are consistently below 0 degrees F, SAE 5W-30 oil can be used. Synthetic oils are not recommended for industrial or stationary engines.

Oil Filter

The filter protects your engine from harmful, abrasive, or sludgy particles without blocking the flow of oil to vital engine parts.

To replace the filter, use a proper filter wrench to remove the filter.

Clean the filter mounting base and lightly coat the gasket surface of the new filter with engine oil. Hand tighten the filter until the gasket contacts the base, then tighten another ½ turn. Fill the engine with the correct amount of oil and run the engine. Verify oil pressure is okay and check for oil leaks at the drain plug and oil filter gasket. Tighten as necessary to stop any oil leakage noted.

Engine Air Cleaner

The engine air cleaner filters air entering the engine intake system and acts as a silencer and flame arrester when assembled to the intake system. Air that contains dirt and grit produces an abrasive fuel mixture and can cause severe damage to the cylinder walls and piston rings. Damage to the cylinder walls and piston rings will cause high oil consumption and shorten engine life. A restricted or dirty air cleaner will also cause a rich fuel mixture. Thus, it is extremely important that the air cleaner be serviced properly at the recommended intervals.

CAUTION: Service the air cleaner more frequently under severe dusty or dirty conditions.

Remove the primary air cleaner element from the air cleaner assembly and inspect the element for foreign material restrictions or signs of excessive wear or damage. Replace the element if necessary. Remove all dust and foreign matter from the air cleaner housing. Reinstall the air cleaner element. Reinstall the air cleaner cup, and securely fasten the retaining clips.

Safety Element

If your engine is equipped with an air cleaner which utilizes a safety element, ensure that the element is properly in place before installing the primary element.

Change the safety element annually.

Cooling System

Coolant Level

Check the coolant level of the radiator daily and only when the engine is cool. Generally a good time to do this is just prior to starting the engine for the first time each day.

Maintain the coolant level at $\frac{3}{4}$ to $1\frac{1}{2}$ inches below the filler neck seat of the radiator when the coolant is cold. When ever coolant level checks are made inspect the condition of the radiator cap rubber seal. Make sure it is clean and free of any dirt particles which would keep it from seating on the filler neck seat. Rinse off with clean water if necessary. Also make sure that the filler neck seat is free of any dirt particles.

WARNING: Never remove the radiator cap under any conditions while the engine is operating. Failure to follow these instructions could result in damage to the cooling system, engine, or cause personal injury. To avoid having scalding hot coolant or steam blow out of the radiator, use extreme caution when removing the radiator cap from a hot radiator. If possible, wait until the engine has cooled, then wrap a thick cloth around the radiator cap and turn slowly to the first stop. Step back while the pressure is released from the cooling system. When all the pressure has been released, press down on the cap and remove it slowly.

DO NOT add coolant to any engine that has become overheated until the engine cools. Adding coolant to an extremely hot engine can result in a cracked block or cylinder head.

The engine manufacturer recommends the cooling system be filled with a 50/50 mixture of antifreeze and water. The use of DexCool "Long Life" type coolant is required. This antifreeze is typically a bright orange in color and should meet the requirements issued by PSI. Coolant should have a minimum boiling point of 300F (149c) and a freezing point no higher than -34F (-37c).

Plain water may be used in an emergency (except in freezing temperatures), but replace it with the specified coolant as quickly as possible to avoid damage to the system.

Radiator

Inspect the exterior of the radiator for obstructions. Remove all bugs, dirt or foreign material with a soft brush or cloth. Use care to avoid damaging the core fins. If available, use low pressure compressed air or a stream of water in the opposite direction of the normal air flow. Check all hoses and connections for leaks. If any of the hoses are cracked, frayed, or feel spongy, they must be replaced.

Fan Belts

The water pump is belt driven. The same belt may also drive the fan and/or the alternator. The drive belts should be properly adjusted at all times. A loose belt can cause improper alternator, fan and water pump operation, in addition to overheating.

Serpentine Belt

Some PSI engines utilize serpentine belts on the front of the engine. This type of belt system incorporates a belt tensioning device which keeps the belt at the proper tension.

This belt should be checked routinely for cracks or 'checking' on the groove side of the belt. If cracks or 'checking' are apparent the belt must be changed.

V-Type Belt

V-Type belts are generally tensioned by adjusting the alternator, or through a mechanical belt tensioner. The belt is generally correctly tensioned when there is 7-10mm of deflection on the belt between the water pump and alternator.

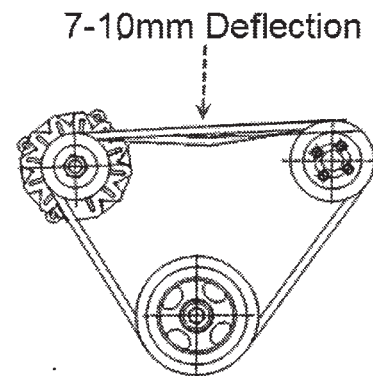

Fuel Filter

LPG Engines

LP, fuel like all other motor fuels is subject to contamination from outside sources. Refueling of the equipment tank and removal of the tank from the equipment can inadvertently introduce dirt and other foreign matter into the fuel system. It is therefore necessary to filter the fuel prior to entering the fuel system components down stream of the tank. An inline fuel filter has been installed in the fuel system to remove the dirt and foreign matter from the fuel, which is replaceable as a unit only. Maintenance of the filter is critical to proper operation of the fuel system and should be replaced according to the maintenance schedule or more frequently under severe operating conditions.

Fuel Shut-Off

LPG and NG engines are equipped with a fuel shut-off. The fuel shut-off is located between the fuel supply and the IEPR/DEPR. The purpose of the fuel shut off is to prevent or allow fuel flow from the supply source to the engine fuel system. The shut off is a 12 volt solenoid (Normally closed) that is controlled by the engine ECM.

Ignition Systems

Types of Ignition Systems

PSI engines use two types of ignition systems. 1) Distributor-less electronic ignition and 2) High Voltage Switch (HVS) ignition. Both types of ignition are controlled by the engine ECU. Distributor-less electronic ignition is utilized on the 1.6L and 8.1L engines. All other engine models use a HVS ignition system which consists of a distributor and HVS ignition coil.

Ignition Timing

Proper adjustment of the ignition timing must be obtained to provide the optimum engine power output and economy. Ignition timing for both the Distributor-less and HVS systems are controlled by the ECU and is not adjustable.

NOTE: Do not attempt to adjust timing on the ignition systems. Timing is not adjustable.

Spark Plugs

Spark plugs should be replaced at the recommended intervals described in the Maintenance Schedule. Use only the recommended spark plug or an equivalent as described in the General Specifications.

Spark plug gap, should be adjusted as recommended in the General Specifications.

When removing spark plugs, always note which cylinder each plug came out of. Look at the porcelain around the center electrode of each plug. You can detect many engine problems from the color and type of deposits that have built up on the white porcelain. For example, if the deposits are a glossy brown, that cylinder is burning excess oil. If the deposits are a very dark gray or sooty black color, your engine is running rich, and you are burning excess fuel. The optimum color of the deposits on the porcelain is light tan or light brown. This shows optimum fuel mixture and proper engine running conditions. If the deposits are almost white, the engine may be running excessively lean.

Lean running is very detrimental to your engine life, and should be corrected immediately. If one or more cylinders are burning oil, the smoke from the engine will be a blue-gray color. Most common causes are piston rings (worn out or not broken in) and valve stem seals (cut, nicked, or worn out). If

the engine is running rich the exhaust smoke will be a sooty black color and it will smell like gasoline (on gasoline engines).

Storage

One to Six Months

If the engine or machine is to be placed in storage for a period of one to six months it is recommended that the following steps be followed:

- Protect the air cleaner inlet from water entry
- Protect the exhaust outlet or muffler outlet from water entry
- Check the coolant protection and top off radiator
- Store indoors if possible

For Extended Periods

Follow the above recommended procedures, plus do the following:

- Drain the engine crankcase and refill with recommended oil
- Change the oil filter
- Disconnect and remove the battery
- Clean exterior surface of the engine
- If the engine is equipped with an automotive type clutch or PTO clutch, make sure that the clutch is disengaged

Removing the Engine From Extended Storage

When removing the engine from extended storage:

- Install a fully charged battery
- Remove all protective coverings from the air inlet, air cleaner, exhaust, and muffler openings
- Check the coolant level in the radiator and verify the protection level of the coolant
- Check the engine oil level.
- Start the engine and allow it to run at slow idle. Verify engine oil pressure
- Run the engine at idle until the coolant temperature approaches 120 degrees F (49 degrees C)
- Run the engine a various speeds for approximately 15 minutes
- Shut the engine down, drain the oil, change the oil filter, and re-fill with the recommended grade of oil

CERTIFIED STATIONARY ENGINE MAINTENANCE REQUIREMENTS

Perform the following maintenance on the engine at the hours indicated and at equivalent hour intervals thereafter.										
	Interval Hours									
	Daily	1000	1500	2000	2500	3000	3500	4000	4500	5000
General Maintenance Section										
Visual check for fluid leaks	X									
Check engine oil level	X									
Check coolant level	X									
Change engine oil and filter	Every 150 hours or 120 days of operation									
Check LPG system for leaks	Prior to any service or maintenance activity									
Inspect accessory drive belts for cracks, breaks, splits or glazing		X		X		X		X		X
Inspect electrical system wiring for cuts, abrasions or corrosion				X				X		
Inspect all vacuum lines and fittings for cracks, breaks or hardening				X				X		
Engine Coolant Section										
Clean debris from radiator core	Every 100 hours or 60 days of operation									
Change coolant		X		X		X		X		X
Inspect coolant hoses for cracks, swelling or deterioration		X		X		X		X		X
Base Engine – Prime Engines										
Compression Test			X			X			X	
Replace/Rebuild Cylinder Heads					X					X
Base Engine – Turbo Charged Emergency Engines										
Replace/Rebuild Cylinder Heads		X		X						
Replace Turbo Charger										
Engine Ignition System										
Replace spark plugs		X		X		X		X		X
Clean secondary ignition coil tower		X		X		X		X		X
Check spark plug wires for cuts abrasions or hardening		X								
Replace distributor cap and rotor				X				X		
Replace spark plug wires				X				X		
Fuel System Maintenance										
Inspect air cleaner	Every 200 hours, or every 100 hours in dusty environment									
Replace filter element	Annually, or as required in dusty environments									
Replace fuel filter		X		X		X		X		X
Inspect Shut-off Valve for leaks and closing				X				X		
Leak check fuel lines				X				X		
Check air induction for leaks		X		X		X		X		X
Check manifold for vacuum leaks		X		X		X		X		X
Drain Vaporizer oil build up	Every 2500 hrs									
Engine Exhaust System										
Inspect exhaust manifold for leaks				X				X		
Inspect exhaust piping for leaks				X				X		
Check HEGO sensor(s) connector and wires for burns, cuts or damage				X				X		
Inspect catalyst for mechanical damage				X				X		

GENERAL SPECIFICATIONS

Power Solutions, Inc.

GM Powertrain Industrial Engines

Engine	1.6L	3.0L	4.3L	5.0L/5.7L	8.1L/8.1L Turbo
Type	1.6-2V	3.0L L4	4.3L V-6	5.7L V-8 GEN-1E	8.1L V-8
Displacement cc (c.i.d.)	1600 (98)	2966 (181)	4294 (262)	5735 (350)	8127 (496)
Compression Ratio	9.5:1	10.5:1	9.4:1	9.4:1	9.1:1
Valve Configuration	Overhead Cam	Push Rod Actuated Overhead Valve	Push Rod Actuated Overhead Valve	Push Rod Actuated Overhead Valve	Push Rod Actuated Overhead Valve
Valve Lifters	Hydraulic	Flat Follower	Hydraulic Roller	Hydraulic Roller	Hydraulic Roller
Bore x Stroke mm (inches)	79.0x81.5 (3.11x3.21)	101.60x91.44 (4.00x3.60)	101.60x88.39 (4.00x3.48)	101.60x88.39 (4.00x3.48)	107.95x111 (4.25x4.37)
Main Bearing Caps	2 Bolt	2 Bolt	2 Bolt	2 Bolt	4 Bolt
Balance Method	External	External	Internal Balance Shaft	External	External
Intake Manifold	Mixer	Mixer	Mixer	Mixer	Mixer
Firing Order	1-3-4-2	1-3-4-2	1-6-5-4-3-2	1-8-4-3-6-5-7-2	1-8-7-2-6-5-4-3
Oil Capacity	3.4 qts. (3.2L)	4 qts. (3.8L)	4.5 qts. (4.3L)	4.5 qts. (4.3L)	8 qts. (7.6L)
With Oil Filter	3.7 qts. (3.5L)	5 qts. (4.7L)	5 qts. (4.7L)	5 qts. (4.7L)	9 qts. (8.5L)
Oil Filter		PF-25 or Equivalent	PF-47/PF-52 or Equivalent	PF-1218 or Equivalent	PF-454 or Equivalent
Minimum Oil Pressure (Hot)	21 psi @ idle	6 psi @ 1000 rpm 18 psi @ 2000 rpm	6 psi @ 1000 rpm 18 psi @ 2000 rpm	6 psi @ 1000 rpm 18 psi @ 2000 rpm	5 psi @ 1000 rpm 15 psi @ 2000 rpm
Coolant Capacity (Engine)	3.5 qts.	4 qts. (3.78L)	7.75 qts. (7.3L)	8.1 qts (7.8L)	14.5 qts (13.7L)
Coolant Capacity (W/PSI Rad)	10 qts	12 qts. (11.4L)	17 qts. (16L)	17.5 qts. (16.6L)	28 qts (26.5L)
Fuel Type	NG, LPG	LPG, NG	LPG, NG	LPG, NG	LPG, NG
Engine Rotation (Flywheel End)	CCW	CCW	CCW	CCW	CCW
Ignition System	Distributor-less Electronic (ECU)	High Voltage Switch (HVS)	High Voltage Switch (HVS)	High Voltage Switch (HVS)	Distributor-less Electronic (ECU)
Ignition Timing	ECM Controlled Not Adjustable	ECM Controlled Not Adjustable	ECM Controlled Not Adjustable	ECM Controlled Not Adjustable	ECM Controlled Not Adjustable
Spark Plugs	AC Delco 93206675	AC Delco R42LTS or R44LTS	AC Delco R42LTS or R44LTS	AC Delco R42LTS or R44LTS	AC Delco R42LTS or R44LTS
Spark Plug Gap	0.035"	0.035"	0.035"	0.035"	0.035"
Valve Clearance (Lash)					
Intake	No Adjustment	½ to 1 Turn Down From 0 Lash	Net Lash	1 Turn Down From 0 Lash	Net Lash
Exhaust	OHC Engine		No Adjustment		No Adjustment
Manufactured	Toluca, Mexico	Toluca, Mexico	Tonawanda, NY	Toluca, Mexico	Tonawanda, NY
Revised 1/2008					

