

OPERATION & MAINTENANCE MANUAL

MITSUBISHI DIESEL ENGINE S16R

NOTE

The operator and supervisor are requested to read this Operation and Maintenance Manual carefully before operating the engine or conducting inspection and maintenance.

Never operate the engine or conduct maintenance work without completely understanding this manual.

October 2003



INTRODUCTION

This manual contains information for operation, inspection and maintenance of the Mitsubishi Engines.

Please read this manual carefully to understand the operation, inspection and maintenance procedures in order to use the engine properly.

Failure to follow directions in this manual can lead to serious accidents.

Limited Warranty

The manufacturer, at its option, will repair or replace any parts returned intact to the manufacturer only when the manufacturer, upon inspection, determines to be defective in material and/or workmanship.

The foregoing shall constitute the limited warranty provided by the manufacturer.

The manufacturer will provide the limited warranty only to the user with whom the manufacturer concludes the original contract, and shall not provide the limited warranty to a user to whom the ownership of the product may be transferred.

- The manufacturer makes no warranties, either express or implied, except as provided in this manual, including without limitation thereof, warranties as to marketability, merchantability, fitness for a particular purpose or use, or against infringement of any patent.
- The manufacturer will not be liable for any damages or consequential damages, including without limitation thereof, damages or other costs resulting from any abuse, misuse, misapplication of the engine and devices supplied by the manufacturer.
- The manufacturer will not be liable for any damages or personal injuries resulting from any modification, without the manufacturer's written permission, of the engine and devices supplied by the manufacturer.
- The manufacturer will not be liable for any damages or production losses caused by the use of fuel, engine oil and/or long life coolant that are not recommended by the manufacturer.

Important Information

- To avoid potential hazard, accident prevention activities must be planned methodically and conducted continually by considering all aspects of engine operation, maintenance and inspection. Everyone including managers and supervisors should actively participate, recognize one's role and organize oneself and one's work to ensure a safe environment.
- The foremost safety objective is to prevent accidents which could result in injury or death, or damage equipment.
- Observe all related federal/national and local codes and regulations to reduce the possibility of personal injury.
- The manufacturer cannot foresee all potential danger of the engine, potential danger resulting from human error and others, or danger caused by a specific environment in which the engine is used.

Since there are many actions that cannot be performed or must not be performed, it is not possible to indicate every caution in this manual or on warning labels. As such, it is extremely important to follow directions in this manual and also to take general safety measures when operating, maintaining and inspecting the engine.

- This manual has been prepared for people whose native language is English. When the engine is used by individuals whose native language is not English, the customer is requested to provide thorough safety guidance to the operators. Also add safety, caution and operating signs that describe the original warning label statements in the native language of the operators.
- The engine must be operated, maintained and inspected only by qualified persons who have thorough knowledge of engines and their danger and also received danger avoidance training.
- To prevent occurrence of an accident, do not attempt to carry out any operation other than those described in this manual, or to use the engine for any unapproved purpose.
- When the ownership of the engine is transferred, be sure to provide this manual with the engine to the new owner. Also inform the manufacturer of

the name and address of the new owner of the engine.

- This manual is copyrighted and all rights are reserved. The drawings and technical reference, including this manual, may not, in whole or in part, be duplicated, photocopied, translated, or reproduced in any electronic medium or machine readable form without prior written consent from the manufacturer.
- The contents in this manual are subject to change without notice for improvement of the engine.
- Your engine may differ from the photographs and figures in this manual.
Please note that, depending on specifications, items described in this manual may differ from those on your engine in shape, or may not be installed on your engine.
- If you need more detailed information or have questions, contact a Mitsubishi dealer.
- If this manual is misplaced, obtain a new copy from a Mitsubishi dealer as soon as possible.





Warnings

The following two methods are used to call the attention of the operators and maintenance personnel to the potential danger of the engine.

- Warning statements in the manual
- Warning labels affixed on the engine

Warning Statements

The warning statements in this manual describe potential danger in operating, inspecting or maintaining the engine by using the following five classifications to indicate the degree of potential hazard. Failure to follow these directions can lead to serious accidents which can result in personal injury, or death in the worst case.

	Indicates a highly hazardous situation which, if not avoided, can result in death or serious injury.
	Indicates a potentially hazardous situation which, if not avoided, can result in death or serious injury.
	Indicates a potentially hazardous situation which, if not avoided, can result in minor or moderate injury.
	Indicates a potentially hazardous situation which, if not avoided, can result in property damage.
	Indicates important information or information which is useful for engine operation.

Explanation of Terms

Abbreviations, Standards and Others

- API = American Petroleum Institute
- ASTM = American Society for Testing and Materials
- JIS = Japanese Industrial Standards
- MIL = Military Specifications and Standards (U.S.)
- MSDS = Material Safety Data Sheet
- SAE = Society of Automotive Engineers (U.S.)
- LLC = Long Life Coolant

Units of Measurement

Measurements are based on the International System of Units (SI), and they are converted to the metric system units in this manual based on the following conversion rates.

- Pressure: 1 MPa = 10.197 kgf/cm²
- Torque: 1 N·m = 0.10197 kgf·m
- Force: 1 N = 0.10197 kgf
- Horsepower: 1 kW = 1.341 HP = 1.3596 PS
- Meter of mercury: 1 kPa = 0.7 cmHg
- Meter of water: 1 kPa = 10.197 cmH₂O (cmAq)
- Engine speed: 1 min⁻¹ = 1 rpm

CONTENTS

Chapter 1

BASIC SAFETY PRECAUTIONS

Warning Fire and Explosion	1-1
Keep flames away	1-1
Keep engine and surrounding area clean	1-1
Never open crankcase until engine cools	1-1
Check for fuel, oil and exhaust gas leaks	1-1
Use flameproof light	1-1
Do not short electrical wires	1-1
Keep fire extinguishers and first-aid kit nearby	1-1
Warning Stay Clear of All Rotating and Moving Parts	1-2
Install protective covers on rotating parts	1-2
Check surrounding area for safety	1-2
Stay clear of all rotating and moving parts while engine is operating	1-2
Lock out and Tag out	1-2
Always stop engine before inspection and maintenance	1-2
Always return turning tools to original position	1-2
Warning Be Careful of Burns	1-3
Do not touch engine during operation or immediately after operation	1-3
Open radiator filler cap carefully	1-3
Add coolant only after coolant temperature drops	1-3
Do not dismount heat protection covers	1-3
Warning Be Careful of Exhaust Fume Poisoning	1-3
Perform engine operation in a well-ventilated site	1-3
Warning Protect Ears from Noises	1-3
Wear earplugs	1-3
Warning Be Careful When Lifting Engine	1-4
Lifting engine carefully	1-4
Do not climb onto engine	1-4
Always watch your footing	1-4
Caution Be Careful of Handling Engine Oil and LLC	1-4
Use only specified fuel, engine oil and coolant (LLC)	1-4
Handle LLC carefully	1-4
Properly dispose of drained oil and LLC	1-4
Caution Service Battery	1-5
Handle battery carefully	1-5

Caution When Abnormality Occurs	1-5
If engine overheats, conduct cooling operation before stopping engine	1-5
If engine stops due to abnormality, exercise caution when restarting	1-5
If oil pressure drops, stop engine immediately	1-5
If V-belt breaks, stop engine immediately	1-5
Caution Other Cautions	1-6
Never modify engine	1-6
Never break seals	1-6
Perform all specified pre-operation inspections and periodic inspections	1-6
Perform engine break-in	1-6
Warm up engine before use	1-6
Never operate engine under overload condition	1-6
Conduct cooling operation before stopping engine	1-6
Do not splash water on engine	1-6
Conduct proper maintenance of air cleaner	1-7
Observe safety rules at workplace	1-7
Wear proper work clothes and protective gear	1-7
Use appropriate tools for maintenance work	1-7
Do not operate starter for prolonged time	1-7
Do not turn off battery switch while engine is operating	1-7
Cautions concerning transportation	1-7
Caution About Warning Labels	1-8
Maintain and inspect warning labels	1-8
Warning labels	1-8

Chapter 2

NAME OF PARTS

Engine External Diagrams	2-1
Left View	2-1
Right View	2-1
Equipment and Instrument	2-2
Starting and Shutdown Devices	2-2
Start Switch	2-2
Stop Switch	2-2
Manual stop lever	2-2
Stop Solenoid	2-2
Instruments	2-3
Oil Pressure Unit	2-3
Thermo Unit	2-3
Revolution Detection Pickup	2-3
Engine Protection Devices	2-4

Oil Pressure Switch	2-4
Oil Filter Alarm Switch	2-4
Thermo Switch.....	2-4
Air Cleaner Indicator	2-5
Using Turning Gear	2-6

Chapter 3 OPERATION

Fuel System	3-1
Pouring fuel.....	3-1
Bleed the fuel system	3-2
Priming pump cap tightening method	3-3
Lubricating System.....	3-4
Pouring engine oil.....	3-4
Cooling System.....	3-5
Pouring coolant.....	3-5
Checking Battery.....	3-6
Electrolyte level.....	3-6
Inspecting specific gravity of electrolyte	3-6
Test Operation	3-7
Starting and stopping.....	3-7
Inspection	3-7
Normal Engine Operation	3-8
Preparations for Operation	
(Pre-Start Inspection)	3-8
External Inspection	3-8
Checking Fuel Level in Tank	3-9
Checking Engine Oil Level.....	3-9
Checking Coolant Level.....	3-10
Checking Fuel Control Link.....	3-10
Air cleaner indicator	3-11
Inspection of Air Tank Air Pressure	3-11
Draining Water from Air Tank	3-11
Starting	3-12
Warming-up Operation.....	3-12
During warming-up operation	3-12
External inspection during warming-up.....	3-12
Operation	3-13
Stopping.....	3-14
Emergency Stop.....	3-14
Inspection After Stopping.....	3-14

Chapter 4 MAINTENANCE

Cautions concerning maintenance.....	4-1
Stop the engine before checking or adding fuel, oil or coolant	4-1
Handle battery electrolyte carefully	4-1
Handle LLC carefully	4-1
Always wear protective gear	4-1
Use recommended fuel, engine oil and coolant.....	4-1
Perform all pre-start inspections and periodic inspections	4-1
Use only genuine mitsubishi parts	4-1
Fuel	4-2
Recommended fuel	4-2
Handling fuel	4-2
Engine oils	4-4
Properties of engine oils and their influence on engine performance	4-4
Main properties of engine oils	4-4
Dispersibility.....	4-4
Acid neutralization ability	4-4
Viscosity.....	4-4
Recommended engine oil	4-5
Selection of oil viscosity	4-5
Genuine engine oil	4-5
Engine oils in the market.....	4-6
Handling engine oil.....	4-6
Service limits of engine oil.....	4-7
Definition of properties of engine oil	4-7
Engine oil analysis service	4-8
How to order engine oil sampling tool set.....	4-8
Coolant and LLC	4-9
Recommended coolant	4-9
Long life coolant (LLC)	4-9
Genuine-LLC.....	4-9
LLC in the market.....	4-10
Maintenance of LLC	4-10
Replacement intervals of LLC.....	4-10
LLC concentration.....	4-10
Importance of LLC.....	4-11
Characteristics of LLC additive and important notes	4-11
Examples of abnormalities caused by LLC	4-11
Pitting on iron parts.....	4-11

Corrosion of aluminum parts..... 4-11
 Pitting and clogging of radiator 4-11
Filters.....4-12
Electrical parts.....4-12
 Cautions on operating engine in cold weather season4-13
Fuel..... 4-13
 Engine oil 4-13
 Coolant..... 4-13
 Battery..... 4-13
 Maintenance after cold season 4-13

Chapter 5
PERIODIC MAINTENANCE CHART

How to Use Periodic Maintenance Chart.....5-1
 Periodic Maintenance Chart..... 5-1
 Periodic maintenance chart for regular-use engine .. 5-1
 Periodic maintenance chart for emergency engine .. 5-1
 Periodic maintenance chart for general-purpose engine 5-1
 General Definition of Regular-Use Engine, Emergency Engine and General-Purpose Engine.... 5-2
 General definition of regular-use engine..... 5-2
 General definition of emergency engine 5-2
 General definition of general-purpose engine..... 5-2
 Periodic Maintenance Chart for Engine in Regular Use.....5-3
 Periodic Maintenance Chart for Emergency Engine5-5
 Periodic Maintenance Chart for General-Purpose Power Supply Engine.....5-8

Chapter 6
PERIODIC INSPECTION AND MAINTENANCE PROCEDURES

External View.....6-1
 External Inspection..... 6-1
 Inspecting the V-belt and adjusting the belt tension 6-2
 Inspecting the V-belt 6-2
 Adjusting the V-belt tension 6-2
 Inspection of Damper 6-3

External inspection of damper6-3
 Damper temperature management.....6-3
Fuel System 6-4
 Draining Water from Fuel Tank 6-4
 Inspection of Fuel Control Linkage Ball Joints . 6-4
 Cleaning Fuel Tank 6-5
 Changing Fuel Filters 6-6
Lubricating System 6-7
 Changing Engine Oil, Oil Filters and Bypass Oil Filter 6-7
 Draining engine oil6-7
 Oil filters and bypass oil filter6-7
 Pouring engine oil.....6-8
 Inspection of Engine Oil for Mixing of Fuel and Water..... 6-8
 Changing Governor Oil Filter 6-9
Cooling System..... 6-10
 Changing Coolant 6-10
 Draining coolant..... 6-10
 Cleaning the cooling system..... 6-10
 Pouring coolant.....6-11
 Inspection and Cleaning Radiator Fins 6-11
Inlet Exhaust System 6-12
 Inspection of Turbocharger 6-12
 Draining Water From Exhaust Muffler..... 6-12
 Cleaning Pre-Cleaner..... 6-13
 Cleaning and Inspecting Air Cleaner Element 6-14
Electrical System 6-15
 Inspection of Starters 6-15
 Inspection of Alternator 6-15
 Checking Battery 6-16
 Inspecting electrolyte level.....6-16
 Inspecting specific gravity electrolyte.6-16
Air Starter System..... 6-17
 Draining Water and Cleaning Air Starter Strainer..... 6-17
 Draining Water from Air Tank..... 6-17
 Inspection Safety Valve of Air Tank 6-17
 Draining Water from Air Starter Compressor . 6-18

Chapter 7
TRANSPORTATION

Lifting Engine Carefully.....7-1

**Chapter 8
LONG-TERM STORAGE**

Long-term storage8-1
 Storing Engine in Non-operable Condition for More Than 3 Months 8-1
 Preparation for Storage 8-1
 Maintenance during Storage..... 8-1
 Using Engine after Storage..... 8-2
 Storing Engine in Operable Condition for More Than 3 Months 8-2
 Operating Engine for Maintenance Purposes..... 8-2

**Chapter 9
TROUBLESHOOTING**

General Precautions.....9-1
 Contact a Mitsubishi Dealer for Repair Service 9-1
 Examination before Work..... 9-1
 Notes Regarding Contamination 9-1
 Notes Regarding Parts Handling..... 9-1
 Work Safety..... 9-1
 How to Troubleshoot9-2
 Starters Do Not Crank or Crank Slowly, Resulting in Start Failure..... 9-2
 Starters Crank, But Engine Does Not Start..... 9-2
 Other Problems and Countermeasures9-3
 Engine Output is Low 9-3
 Exhaust Smoke is White or Blue 9-3
 Exhaust Smoke is Black or Dark Gray 9-4
 Fuel Consumption is High..... 9-4
 Engine Oil Consumption is High 9-4
 Engine Overheats 9-5
 Engine Oil Pressure is Faulty 9-5
 When Fuel Has Run Out9-5

**Chapter 10
MAIN SPECIFICATIONS**

Main Specifications.....10-1

List of Illustrations

fig.1-1 Warning labels 1-8

fig.2-1 Left view2-1
 fig.2-2 Right View2-1
 fig.2-3 Start switch and stop switch.....2-2
 fig.2-4 Manual Stop Lever2-2
 fig.2-5 Stop Solenoid.....2-2
 fig.2-6 Oil Pressure Unit.....2-3
 fig.2-7 Thermo Unit2-3
 fig.2-8 Revolution Detection Pickup2-3
 fig.2-9 Oil Pressure Switch.....2-4
 fig.2-10 Oil Filter Alarm Switch.....2-4
 fig.2-11 Thermo Switch2-4
 fig.2-12 Air Cleaner Indicator2-5
 fig.2-13 Turning gear position (Engine in operation). 2-6
 fig.2-14 Turning gear position (Shaft pushed in).2-6
 fig.2-15 Turning gear position (Turning shaft)2-6
 fig.3-1 Using the priming pump3-2
 fig.3-2 Fuel filters3-2
 fig.3-3 Fuel injection pump3-2
 fig.3-4 Priming pump cap tightening method.....3-3
 fig.3-5 Priming pump cap packing.....3-3
 fig.3-6 Oil filler and oil level gage3-4
 fig.3-7 Pouring engine oil on valve mechanisms and chamber3-4
 fig.3-8 Coolant drain cock on the engine.....3-5
 fig.3-9 Coolant drain cock on the water pump.....3-5
 fig.3-10 Radiator coolant level.....3-5
 fig.3-11 Coolant level in reserve tank.....3-5
 fig.3-12 Inspecting electrolyte level.3-6
 fig.3-13 Inspecting specific gravity of electrolyte.....3-6
 fig.3-14 Checking valves for open/closed position.....3-8
 fig.3-15 Oil filler and oil level gage3-9
 fig.3-16 Radiator cap.....3-10
 fig.3-17 Radiator coolant level.....3-10
 fig.3-18 Reserve tank coolant level.....3-10
 fig.3-19 Checking fuel control link3-10
 fig.3-20 Air cleaner indicator3-11
 fig.3-21 Inspection of Air Tank Air Pressure.....3-11
 fig.3-22 Draining water from air tank.....3-11
 fig.3-23 Manual stop lever.....3-14
 Fig.4-1 Recommended fuel4-2
 Fig.4-2 Recommended fuel according to

air temperature 4-2

Fig.4-3 Recommended engine oil 4-5

Fig.4-4 Recommended oil viscosity according to air temperature 4-5

Fig.4-5 Jukoil cojera,new mariner 4-5

Fig.4-6 Engine oil sampling tool set 4-8

Fig.4-7 GLASSY - LLC 4-9

fig.6-1 Inspecting the V-belt and adjusting the belt tension..... 6-2

fig.6-2 External inspection of damper..... 6-3

fig.6-3 Managing the damper temperature 6-3

fig.6-4 Clean fuel tank 6-4

fig.6-5 Inspection of the fuel control linkage for looseness 6-4

fig.6-6 Removing the fuel control linkage 6-4

fig.6-7 Cleaning fuel tank 6-5

fig.6-8 Changing fuel filters 6-6

fig.6-9 Fuel filter 6-6

fig.6-10 Oil filters and bypass oil filter 6-7

fig.6-11 Oil filter 6-7

fig.6-12 Oil filter and oil level gage 6-8

fig.6-13 Governor oil filter..... 6-9

fig.6-14 Changing governor oil filter 6-9

fig.6-15 Radiator cap..... 6-10

fig.6-16 Draining coolant (Engine main parts) 6-10

fig.6-17 Draining coolant (Water pump) 6-10

fig.6-18 Radiator..... 6-11

fig.6-19 Reserve tank..... 6-11

fig.6-20 Cleaning radiator fins 6-11

fig.6-21 Inspection of turbocharger 6-12

fig.6-22 Draining water from exhaust muffler 6-12

fig.6-23 Cleaning Pre-Cleaner..... 6-13

fig.6-24 Removing air cleaner element 6-14

fig.6-25 Cleaning air cleaner element 6-14

fig.6-26 Inspecting air cleaner element 6-14

fig.6-27 Air cleaner indicator 6-14

fig.6-28 Inspection of starters 6-15

fig.6-29 Inspection of alternator..... 6-15

fig.6-30 Inspecting electrolyte level 6-16

fig.6-31 Inspecting specific gravity electrolyte 6-16

fig.6-32 Air starter strainer..... 6-17

fig.6-33 Draining water from air tank.....6-17

fig.6-34 Inspection safety valve of air tank.....6-17

fig.6-35 Air starter compressor.....6-18

fig.7-1 Hangers for lifting7-1

fig.7-2 The center of gravity for the engine7-1

List of Tables

Table 3-1 Specific gravity of electrolyte.....3-6

Table 3-2 Data for rated speed3-13

Table 4-1 Recommended Fuel4-2

Table 4-2 Recommended and limit values of fuel property4-3

Table 4-3 Service Limit for Engine Oil Properties....4-7

Table 4-4 Engine oil sampling tool sets4-8

Table 4-5 Water quality standards.....4-9

Table 4-6 Recommended LLC concentration (for reference only)4-10

Table 5-1 Periodic Maintenance Chart for Engine in Regular Use.....5-3

Table 5-2 Periodic Maintenance Chart for Emergency Engine5-5

Table 5-3 Periodic Maintenance Chart for General-Purpose Power Supply Engine5-8

Table 6-1 Temperature Management with Thermo Label.....6-3

Table 6-2 Specific gravity of electrolyte.....6-16

Table 8-1 Recommended Rust-preventive Oil and Corrosion Inhibitor.....8-1

Table 9-1 Starters Do Not Crank or Crank Slowly, Resulting in Start Failure9-2

Table 9-2 Starters Crank, But Engine Does Not Start9-2

Table 9-3 Engine Output is Low9-3

Table 9-4 Exhaust Smoke is White or Blue9-3

Table 9-5 Exhaust Smoke is Black or Dark Gray9-4

Table 9-6 Fuel Consumption is High9-4

Table 9-7 Engine Oil Consumption is High.....9-4

Table 9-8 Engine Overheats.....9-5

Table 9-9 Engine Oil Pressure is Faulty9-5

Table 10-1 Main Specifications..... 10-1

Chapter 1

BASIC SAFETY PRECAUTIONS

Warning Fire and Explosion

Keep flames away

Store fuel and engine oil in a well-ventilated area.

Make sure that the caps of fuel and engine oil containers are tightly closed, and store them in the designated site.

Do not use flames or smoke where fuel or oil is handled or cleaning solvent is used for washing parts.

Spilled fuel, oil and LLC should be wiped immediately and thoroughly. Spilled fuel, oil and LLC can ignite and cause fire.



Keep engine and surrounding area clean

Do not store combustible (such as fuel, engine oil and LLC), explosive or dangerous materials near the engine. Those substances can cause a fire or explosion.

Keep the engine and the surrounding area free of dust, dirt and foreign materials, since they can cause fire or the engine to overheat.

Clean the top surface of the battery after performing maintenance work. Dust on the battery may cause a short-circuit.

The engine must be used at least 1 m [3.3 ft.] away from buildings and other equipment to prevent possible fire caused by engine heat.

Never open crankcase until engine cools

If the cover is opened while the engine is still hot, fresh air comes into crankcase and oil mist can be ignited by engine heat, then it may lead to the explosion of the engine.

Never open the engine crankcase cover before the engine becomes cool, wait at least 10 minutes after the engine stops.

Check for fuel, oil and exhaust gas leaks

Inspect fuel, oil and exhaust pipes regularly for damage and looseness. If a fuel, oil and exhaust gas leak is found, repair the leakage immediately. Fuel or oil spilled on a hot surface of the engine, and exhaust gas blown onto a combustible material may cause fire and result in personal injury and/or damage to equipment.

Use flameproof light

When inspecting fuel, engine oil, coolant, battery electrolyte, etc., use a flameproof light. An ordinary light may ignite and cause an explosion.

Do not short electrical wires

Before inspecting or servicing any electrical component, disconnect the ground cable from the negative (-) battery terminal to prevent short-circuit and fire.

Loose terminals or damaged cables/wires can cause a short-circuit that may result in fire. Before operating the engine, inspect the cables and wires, and repair or replace if necessary.

Keep fire extinguishers and first-aid kit nearby

Keep fire extinguishers nearby, and be familiarized with their usage.

Keep a first-aid kit at the designated place, and make sure it is easily accessible at anytime.

Establish response procedures to follow in the event of fire or accident, and post information concerning emergency contact locations and their contact methods.



Warning Stay Clear of All Rotating and Moving Parts

Install protective covers on rotating parts

Make sure the protective covers of the engine are correctly installed.

Repair any damaged or loose covers.

When the engine is coupled to other equipment or the radiator, install protective covers on the exposed connecting belt and coupling.

Never remove protective covers for rotating parts such as the damper cover, camshaft cover or rocker cover while the engine is operating.

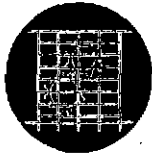

Check surrounding area for safety

Before starting the engine, check to make sure no one is near the engine and tools are not left on or near the engine. Verbally notify persons within the immediate area when starting the engine.

When the starter device is posted with a sign that prohibits startup operation, do not operate the engine.

Stay clear of all rotating and moving parts while engine is operating

Do not approach rotating and moving parts (output shaft, flywheel, fan belts and pulleys) of the engine while the engine is in operation.

Rotating parts can entangle your body or tools and result in serious injury.

Keep items that can be easily entangled by rotating parts away from the engine.

If your body or tool contacts rotating and moving parts, serious injury may occur as a result.



Lock out and Tag out

Be sure to lock out and tag out before starting inspection and maintenance.

Lockout and tagout are effective methods of cutting off machines and equipment from energy sources.

To lock out and tag out, pull out the key from the starter switch, turn off the battery switch, and post a tag on the starter switch indicating "Do Not Operate." The starter key switch should be kept by the person performing the inspection and maintenance. For the air starter system, close the main valve of the air tank, and post a tag indicating "Do Not Open the Valve."

Always stop engine before inspection and maintenance

Be sure to stop the engine before conducting inspection and maintenance. Never attempt to adjust the engine parts while the engine is running. Conducting inspection and maintenance on an operating engine can result in a serious accident of entanglement by rotating parts.

Always return turning tools to original position

Be sure to remove all turning tools used during maintenance and inspection.

Starting the engine with the turning tools inserted or turning gears engaged may not only cause engine damage but personal injury as well.

Warning Be Careful of Burns

Do not touch engine during operation or immediately after operation

Do not touch the main and exhaust parts of the engine during operation or immediately after operation to prevent burns.



To conduct maintenance and inspection, wait until the engine cools sufficiently as indicated with the temperature gage.

Open radiator filler cap carefully

Never open the radiator filler cap while the engine is operating or immediately after it is stopped.

The engine coolant is hot during engine operation and immediately after operation. If the radiator filler cap is opened when the coolant is at operating temperature, steam and hot coolant may blow out, causing skin burns as a result.

When opening the cap, stop the engine and allow the coolant temperature to drop sufficiently. Cover the cap with a cloth or use thick rubber glove, and then slowly open the cap.

When closing the cap, be sure to tighten securely.

Add coolant only after coolant temperature drops

Do not add coolant immediately after the engine stops. Wait until the coolant temperature lowers sufficiently to prevent burns.

Do not dismount heat protection covers

The high-temperature exhaust components are installed with heat protection covers. Do not dismount these heat protection covers. If they must be removed during inspection and maintenance, be sure to reinstall them after completing the inspection and maintenance.

Warning Be Careful of Exhaust Fume Poisoning

Perform engine operation in a well-ventilated site

Exhaust gas from the engine contains carbon monoxide and other harmful substances.

Do not operate the engine in an enclosed area (inside a warehouse, tunnel, etc.) or in a site where all sides are blocked, since exhaust fumes can cause gas poisoning.

If the engine must be operated in an enclosed area, discharge the exhaust gas to the outside and provide adequate ventilation.

Connect an exhaust duct to the exhaust pipe to lead exhaust gas to the outside, and make sure exhaust gas does not leak from the duct joints.

Make sure the exhaust gas does not blow in the direction of plants or animals.



Warning Protect Ears from Noises

Wear earplugs

Be sure to wear earplugs when entering into the engine room.

The earplugs can be quite useful to protect ears from various engine noises.



⚠ Warning Be Careful When Lifting Engine

Lifting engine carefully

To lift the engine, use slings capable of supporting the weight of the engine.

Attach appropriate slings to the hangers on the engine.

Keep the engine balanced during lifting by considering the center of gravity of the engine.

Keep the angle formed by slings attached to hangers within 60°. If the angle exceeds this limit, excessive load is applied on the hangers and may damage the hangers.

If wire ropes contact the engine, place a cloth or other soft padding to prevent damage to the engine and wire ropes.



Do not climb onto engine

Never climb onto the engine.

To work on parts located on the upper section, use a ladder, stand, etc.

Climbing on the engine can not only damage entire parts, but also cause parts to fall off and result in injury.

Always watch your footing

Use a stable work platform to stand on when working on the upper part of the engine and other hard-to-reach places.

Standing on a decrepit stand or parts box may result in personal injury.

Do not put obstacles on the stand.



⚠ Caution Be Careful of Handling Engine Oil and LLC

Use only specified fuel, engine oil and coolant (LLC)

Use fuel, oil and LLC specified in this manual, and handle them carefully.

Use of any other fuel, oil or LLC, and improper handling may cause various engine problems and malfunctions.

Obtain the MSDSs issued by the fuel, oil and LLC suppliers, and follow the directions on the MSDSs for proper handling.

Handle LLC carefully

Wear safety mask and rubber gloves when handling LLC. Avoid contact with skin and eyes to prevent personal injury.

Should LLC be accidentally swallowed, induce vomiting immediately and seek medical attention.

Should LLC enter eyes, flush immediately with plenty of water and seek medical attention. If LLC is spilled on skin or clothes, wash immediately with lot of water.

Keep flammable materials away from LLC to prevent fire. Never use flames or generate sparks near LLC since flames or sparks can cause fire.

Drained LLC is harmful. Do not dispose of into conventional sewage. Contact a Mitsubishi dealer for the disposal of drained LLC.

Properly dispose of drained oil and LLC

Do not dispose of engine oil, used cleaning oil or LLC into conventional sewage.

Prepare drip pan or other containers to receive oil and LLC drained from the engine. Do not drain them directly onto the ground.

For disposal of drained oil and LLC, consult a Mitsubishi dealer.

Caution Service Battery

Handle battery carefully

- Batteries release flammable hydrogen gas and oxygen. Never use flames or generate sparks near the battery since flames or sparks can cause an explosion.
- Do not use the battery when the fluid surface is lower than the minimum required level. Using a battery with a low electrolyte level can result in an explosion.
- Do not short the battery terminals with a tool or other metal object.
- When disconnecting battery cables, remove the cable from the negative (-) terminal first. When reconnecting cables, attach the cable to the positive (+) terminal first.
- Charge the battery in a well-ventilated area, with all filling hole plugs removed.
- Make sure the cable clamps are securely installed on the battery terminals. A loose cable clamp can cause sparks that may result in an explosion.
- Before servicing electrical components or conducting electric welding, set the battery switch to the [OFF] position or disconnect the cable from the negative (-) battery terminal to cut off the electrical current.
- Electrolyte contains dilute sulfuric acid. Careless handling of the battery can cause loss of sight and burns.
- Wear safety goggles and rubber gloves when working with the battery (replenishment of fluid, charging, etc.)
- If electrolyte is spilled on skin or clothes, wash immediately with lots of water. Then, use soap to clean thoroughly.
- If electrolyte enters eyes, flush immediately with lots of fresh water and see a physician as soon as possible.
- Should you accidentally swallow electrolyte, gargle with plenty of water, then drink lots of water. Consult a physician immediately.



Caution When Abnormality Occurs

If engine overheats, conduct cooling operation before stopping engine

If the engine overheats, do not stop the engine immediately. Abrupt stopping of an overheated engine may cause the coolant temperature to rise, resulting in seizing of the engine. If the engine overheats, operate the engine at low idling speed (cooling operation), and stop the engine after the coolant temperature lowers sufficiently.

Do not add coolant immediately after stopping the engine. Adding coolant to a hot engine may cause damage to the cylinder head from sudden change in temperature. Add coolant gradually after the engine cools to room temperature.

If engine stops due to abnormality, exercise caution when restarting

If the engine stops due to an abnormality, do not restart the engine immediately. If the engine stops with an alarm, check and correct the cause of the problem before restarting. Operating the engine without correcting the problem may result in serious engine problems.

If engine oil pressure drops, stop engine immediately

If the engine oil pressure decreases, stop the engine immediately, and inspect the lubricating system including the oil level and pump. Operating the engine with low oil pressure may cause seizing of bearings and other parts.

If V-belt breaks, stop engine immediately

If the V-belt breaks, stop the engine immediately. Continued operation of the engine without the V-belt will cause the alternator to stop working. Continued operation of the engine without the V-belt in place causes coolant to change into steam and blow out, thus resulting in burns.

Caution Other Cautions

Never modify engine

Unauthorized modification of the engine will void the maker's warranty.

Modification of the engine may not only cause engine damage but may result in personal injury as well.

If there is a need to modify the engine, please contact a Mitsubishi dealer.

Never break seals

To ensure proper engine operation, the fuel control links are attached with seals that prevent accidental change of the injection volume and rotation speed settings. Operating the engine without these seals in place can result in the following problems, and also invalidates the warranty.

- Rapid wear of moving and rotating parts
- Engine damage such as seizing of engine parts
- Increased consumption of fuel and lubricating oil
- Degradation of engine performance due to improper balance between fuel injection volume and governor operation.

Perform all specified pre-operation inspections and periodic inspections

Conduct the pre-operation inspections and periodic inspections as described in this manual.

Failure to conduct the specified inspections may cause various engine problems and damage to parts, as well as serious accidents.

Perform engine break-in

Break in a new engine by operating it with a light load and at a speed lower than normal during the first 50 hours of operation.

Operating a new engine under high load or severe conditions during the break-in period can shorten the service life of the engine.

Warm up engine before use

If the auxiliary devices for the starter (water heater, engine oil priming pump etc.) are not installed, let the engine idle for 5 to 10 minutes before using the engine for work.

Warm-up operation circulates lubricants in the engine and contributes to a longer service life and economical operation.

Do not conduct warm-up operation for an extended period of time. Prolonged warm-up operation causes carbon build-up in the cylinders that leads to incomplete combustion.

Never operate engine under overload condition

If the engine shows an overload condition such as the emission of exhaust smoke, decrease the load immediately so that the engine operates at appropriate output and load.

Overloading the engine causes not only high fuel consumption but also excessive carbon deposits inside the engine. Carbon deposits cause various problems and can shorten the service life of the engine.

Conduct cooling operation before stopping engine

Before stopping the engine, let it idle at low speed for 5 to 6 minutes to cool.

Stopping the engine immediately after high-speed operation can cause engine parts to heat up and shorten the service life of the engine.

During cooling operation, check the engine for abnormalities.

Do not splash water on engine

Do not allow rainwater, etc., to enter the engine through the air inlet or exhaust openings.

Do not wash the engine while it is in operation, since the engine may suck in the cleaning fluid (water). If the engine is started with water inside the combustion chambers, water hammer action can *damage the engine and result in serious accidents.*

Conduct proper maintenance of air cleaner

The major cause of abnormal wear on engine parts is dust entering with intake air. Worn parts result in an increase of oil consumption, decrease of output, and starting difficulties. Conduct maintenance of the air cleaner according to the following directions to ensure optimum air filtering performance.

- Do not conduct maintenance of the air cleaner while the engine is operating.
Without the air cleaner in place, the turbocharger can suck foreign particles into the engine, decrease the load immediately so that the engine operates at appropriate output and load.
- When removing the air cleaner, do not allow dust attached on the air cleaner to enter into the engine.
- If equipped with a dust indicator, conduct maintenance only when the clog warning sign appears. While servicing the air cleaner, do not let dust enter into the air cleaner, damage or deform the element.

Observe safety rules at workplace

Observe the safety rules established at your workplace when operating and maintaining the engine.

Do not operate the engine if you are feeling ill. Operation of the engine with reduced awareness may cause accidental operations that may result in accidents. In such case, you should inform your supervisor of your condition.

When working in a team of two or more persons, use specified hand signals to communicate among the workers.

Wear proper work clothes and protective gear

Wear the work clothes specified by your workplace. Wear a hardhat, face shield, safety shoes, dust protective mask, gloves and other protective gear as needed.

When handling compressed air, wear safety goggles, hardhat, gloves and other necessary protective gear. Compressed air may cause personal injury when not wearing the proper protective gear.

Use appropriate tools for maintenance work

Use appropriate tools according to the type of maintenance work, and use them correctly. If tools are damaged, replace with new tools.

Do not operate starter for prolonged time

Do not use the starter for more than 10 seconds at a time. If the engine does not start, wait for at least 30 seconds before cranking again.

Continuous operation of the starter will cause draining of the battery as well as the starter to seize.

Do not turn off battery switch while engine is operating

Do not turn off the battery switch while the engine is in operation.

Turning off the battery switch while the engine is in operation not only stops the instrument operations but also damages the electronic devices on the secondary side.

Cautions concerning transportation

When transporting the engine using a truck, consider the engine weight, width and height to ensure safety. Abide by the pertinent laws and regulations.

Caution About Warning Labels

Maintain and inspect warning labels

Make sure all warning labels are legible.

If the description and/or illustration on a warning label cannot be seen clearly, clean or replace the label.

To clean warning labels, use a cloth, water and soap. Do not use solvents, gasoline or other chemicals to clean warning labels. Cleaning with chemicals may cause the labels to peel off.

If warning labels are damaged or missing, replace with new labels.

If a part of the engine with warning label is replaced with new part, also attach new warning label to the new part.

To obtain replacement warning labels, contact a Mitsubishi dealer.

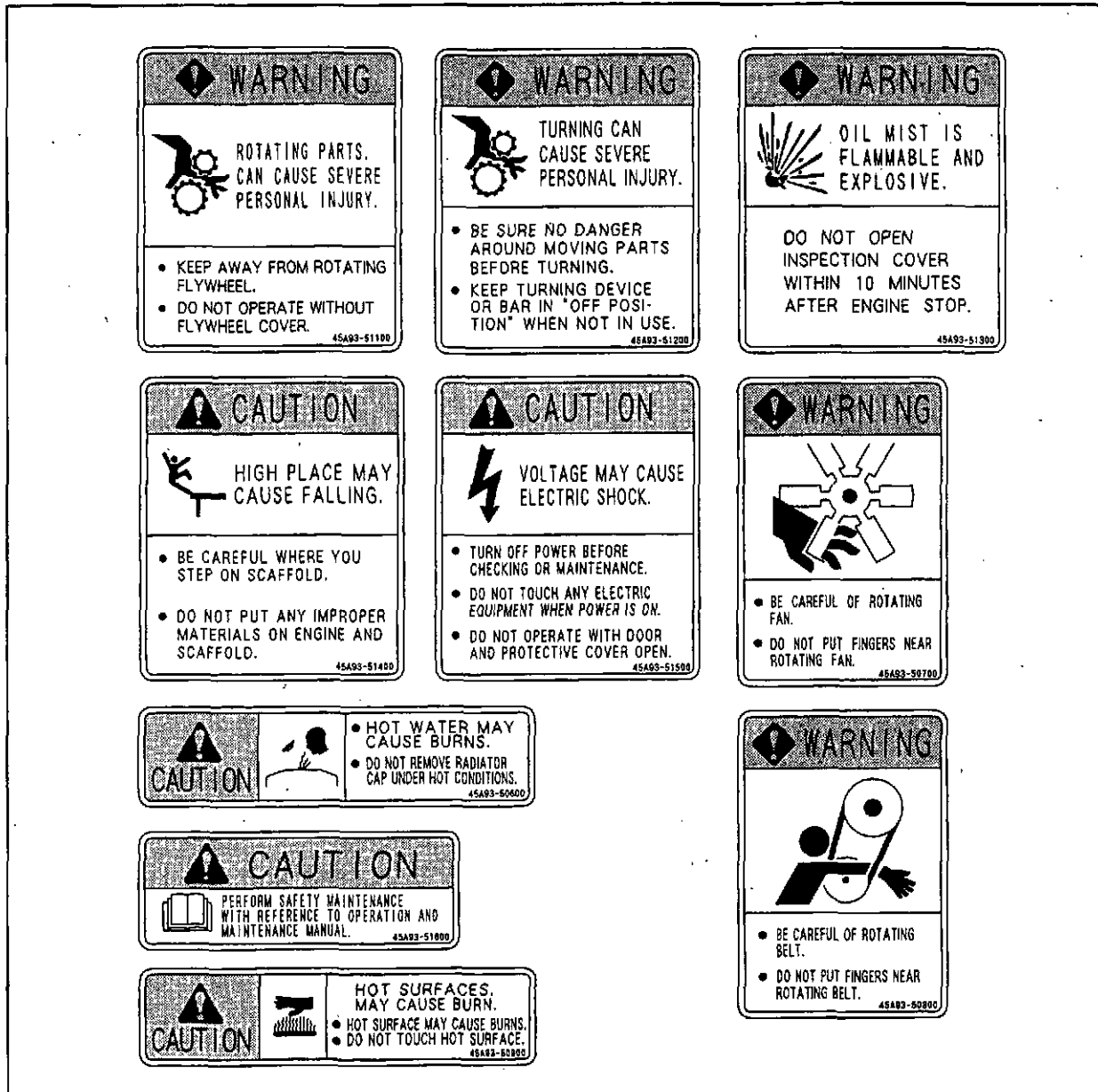

fig. 1-1 Warning labels

Chapter 2

NAME OF PARTS

Engine External Diagrams

The external diagram is for standard type of the engine.

The installed equipment and shapes differ on the engine type.

Left View

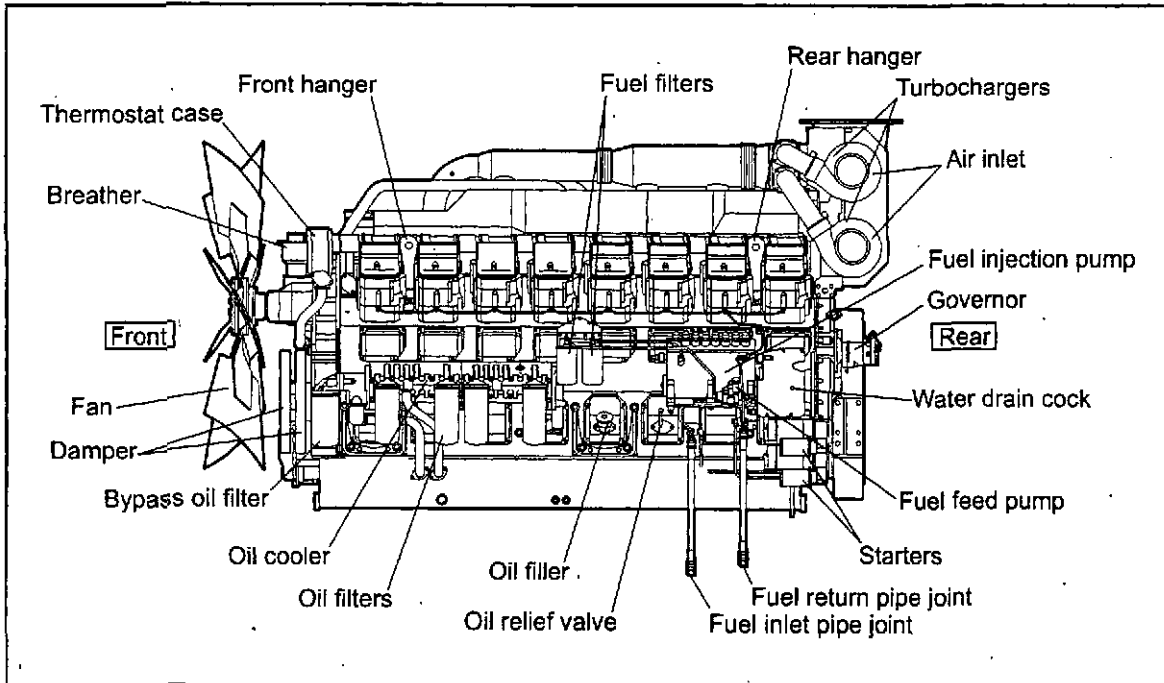

fig.2-1 Left view

Right View

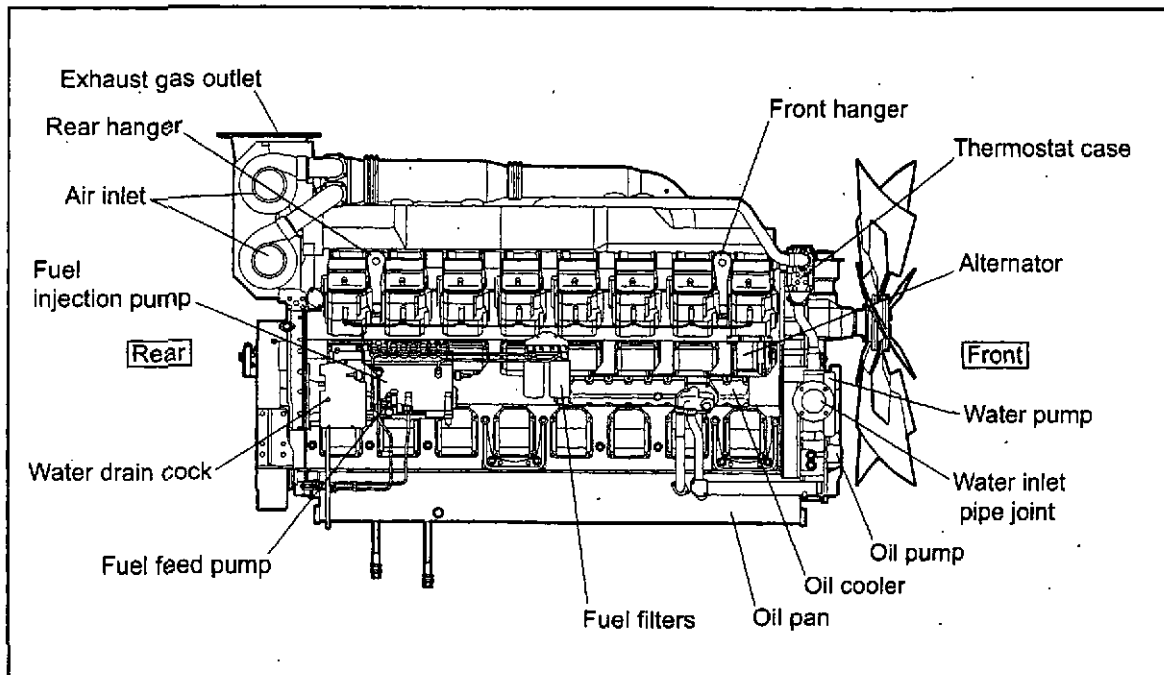

fig.2-2 Right view

Equipment and Instrument Starting and Shutdown Devices

The shape and type of the starting and shutdown devices may vary from those described below depending on the engine specifications.

Start Switch

When the start switch on the operation panel is pressed, starting air is supplied to the air starter system and cranks the engine.

Stop Switch

When the stop switch on the operation panel is pressed, the shutdown cylinder operates and moves the control shaft of the fuel injection pump to the no-injection position to shut down the engine operation.

Manual stop lever

Use the manual stop lever to shut down the engine in the event of an emergency.

If the starter switch fails to stop engine operation, use the manual stop lever.

When the lever is moved in the [STOP] direction, the engine stops operation.

Note: Should the engine continue operating even after the manual stop lever is operated, cut off the fuel supply to stop the engine.

Stop Solenoid

The stop solenoid operates for normal shutdown of engine operation. The stop solenoid moves the rack of the fuel injection pump to stop fuel injection, thus shutting down the engine operation.

The "RUN-ON" type solenoid sets the start switch to the "OFF" position by de-energizing the stop solenoid and pushing the rod out by internal spring power which makes the rack of the fuel injection pump move to the non-injection direction.

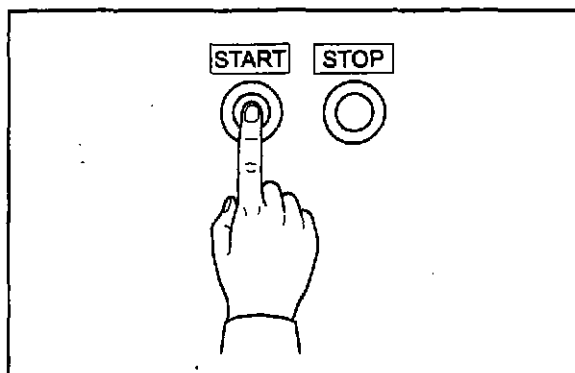

fig.2-3 Start switch and stop switch

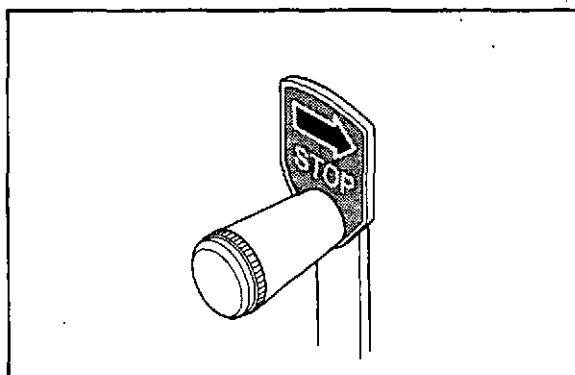

fig.2-4 Manual Stop Lever

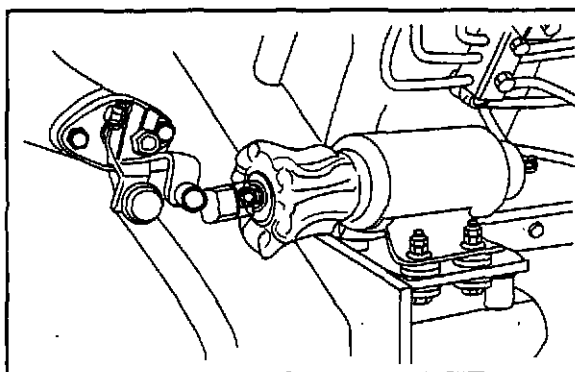

fig.2-5 Stop Solenoid

Instruments

This section describes about devices which transmit signals to necessary instruments of the engine in operation. Please read carefully and understand functions of each device.

Oil Pressure Unit

The oil pressure unit is installed above the oil filter for the detection of engine oil pressure.

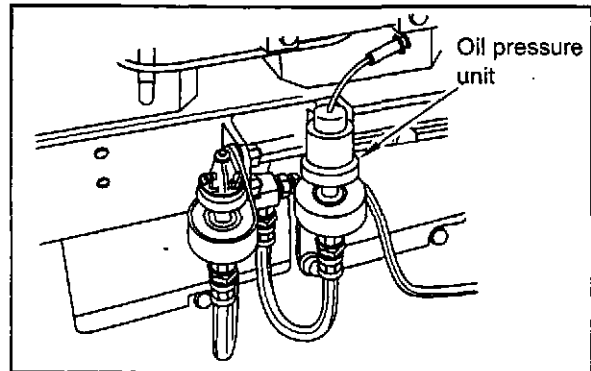

fig.2-6 Oil pressure unit

Thermo Unit

The thermo unit is installed under the thermostat cover for the detection of the temperature of engine coolant. Operating temperature range: 50 to 120°C [122 to 248°F]

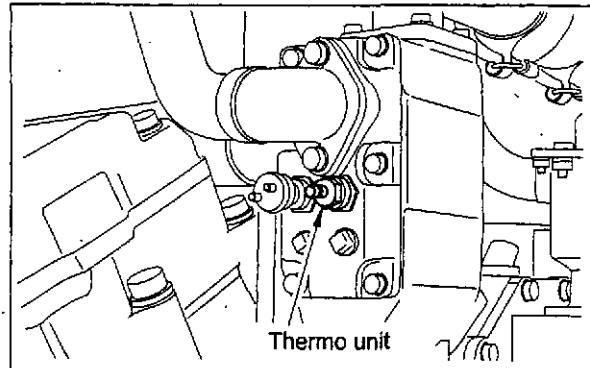

fig.2-7 Thermo unit

Revolution Detection Pickup

The revolution detection pickup is installed on the fly-wheel housing for the detection of engine speed.

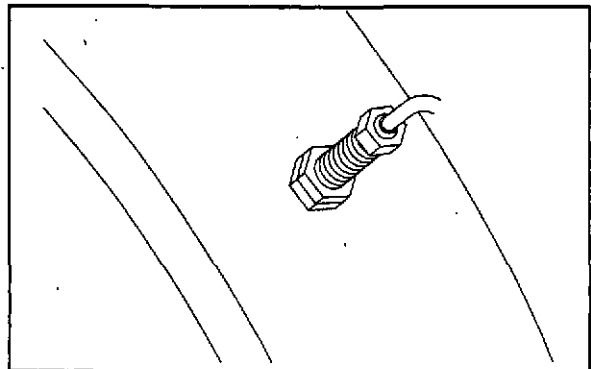

fig.2-8 Revolution Detection Pickup

Engine Protection Devices

The engine protection devices activate an alarm when an abnormality occurs in the engine in order to protect the engine and prevent serious problems and accidents. When a protection device is activated, stop the engine, examine the cause of the abnormality, and take corrective measures.

If the cause of the problem is unknown, contact a Mitsubishi dealer.

Protection devices installed on the engine and their types (setting values) and shapes vary depending on the engine specifications. The following describes the typical protection devices installed in a Mitsubishi engine.

Oil Pressure Switch

The oil pressure switch turns on and generates an alarm when the pressure of engine lubricating oil drops below the preset level. The switch is activated when the oil pressure becomes the entire engine speed range.

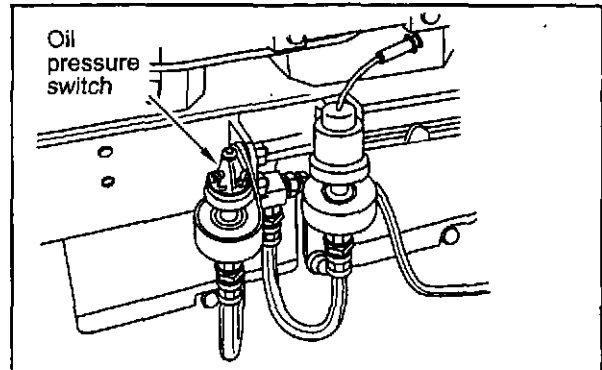

fig.2-9 Oil pressure switch

Oil Filter Alarm Switch

The oil filter alarm switch turns on and generates an alarm when oil filters become clogged. The switch is activated when the pressure difference before and after oil filters reaches the limit. Immediately replace to new oil filter when the alarm is generated and at the same time replace the engine oil.

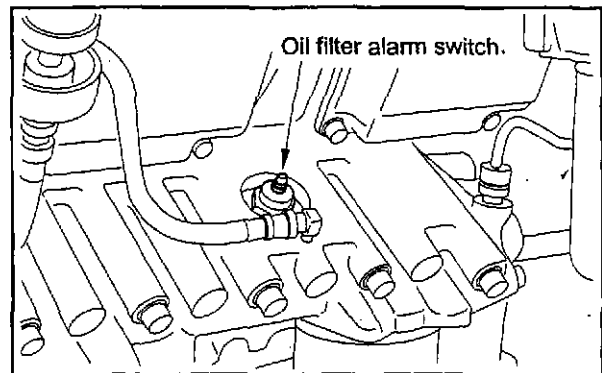

fig.2-10 Oil filter alarm switch

Thermo Switch

A thermo switch is installed to avoid overheating. The thermo switch generates alarm sound when the coolant temperature reaches specified level.

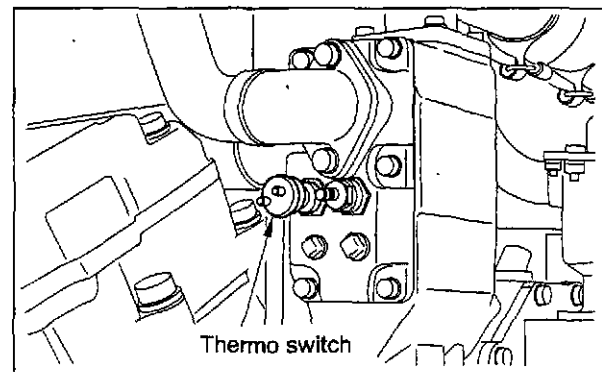

fig.2-11 Thermo switch

Air Cleaner Indicator

When the air cleaner element is clogged, the indicator alarms with its red signal. Be sure to clean the element immediately when alarm signal is shown.

After cleaning, press the button on top of the indicator to re-set the alarm signal.

While serving the air cleaner, do not enter dust into the air cleaner or damage the element.

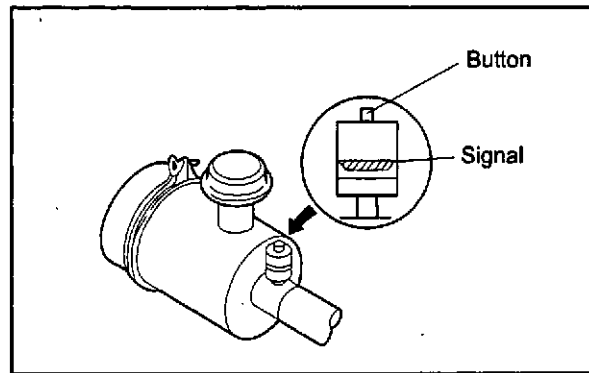

fig.2-12 Air cleaner indicator

Using Turning Gear

▲ WARNING

Before starting the engine, return (pull out) the turning gear to the original position. Starting the engine with the turning gear pushed in not only damages the ring gear but also may result in personal injury.

- 1 Loosen the two bolts, and remove the plate from the shaft groove.

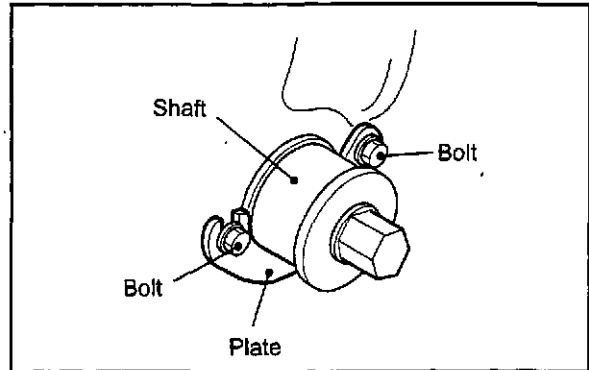

fig.2-13 Turning gear position(Engine in operation)

- 2 Push in the shaft fully to engage it with the ring gear.

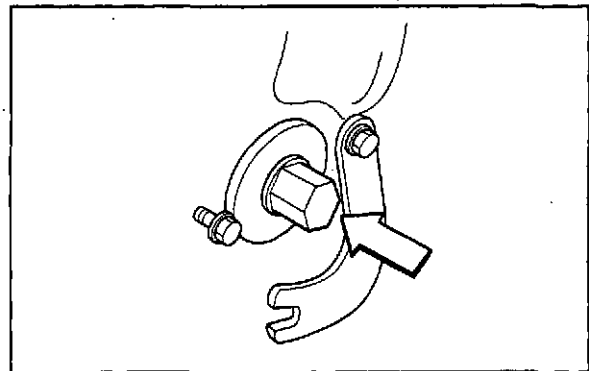

fig.2-14 Turning gear position(Shaft pushed in)

- 3 Turn the shaft using a socket wrench and a ratchet handle.
- 4 After turning, pull out the shaft, insert the plate in the shaft groove, and tighten the bolts.

▲ CAUTION

Make sure the plate is securely inserted in the shaft groove.

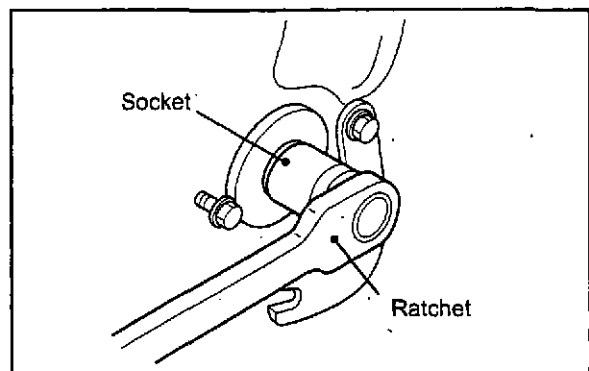

fig.2-15 Turning gear position(Turning shaft)

Chapter 3

OPERATION

Preparation for Operation of New or Overhauled Engine

Before operating a new or overhauled engine, do the following inspection. For second operation onward, do the following normal operation outlined on page 3-8 "Normal Engine Operation".

Fuel System

CAUTION

When handling fuel, make sure there are no flames near the engine.

Wipe any spilled fuel completely. Spilled fuel can ignite and cause fire.

CAUTION

Do not remove the strainer when filling the fuel tank.

Use fuel specified in "Fuel" (4-2).

Pouring fuel

- 1 Make sure the insides of the fuel tank and fuel pipes are clean.
- 2 Pour fuel into the fuel tank.
- 3 Remove the fuel feed pipe and drain plug from the fuel inlet of the engine, and check the discharged fuel for dust particles.
- 4 Reinstall the drain plug and fuel feed pipe.
- 5 Add fuel until the fuel level gage indicates "FULL."

Bleed the fuel system

WARNING

When fuel overflows from the air vent plug, wipe thoroughly with a cloth. Spilled fuel is a fire hazard.

After bleeding, lock the priming pump cap securely. If the cap is not locked tightly, the priming pump can be damaged, causing fuel leakage that may lead to a fire. To lock the priming pump cap, follow the procedure described on the following page.

CAUTION

Closing all air vent plugs before locking the priming pump cap disallows the priming pump cap from returning to the original position due to internal pressure.

Bleed air from the location closest to the fuel tank that are the fuel filters, then the fuel injection pump.

Fuel filters

- 1 Loosen the air vent plug on the fuel filter of the double-filter system by rotating about 1.5 turns.
- 2 Loosen the priming pump cap by turning counterclockwise and move it up and down.
- 3 When there are no air bubbles in the fuel flowing from the air vent plug, tighten the air vent plug to the specified torque.
- 4 Repeat the same procedure with the right fuel filter.
- 5 Repeat the same procedure with the fuel filters located on the other side of the engine.

Fuel injection pump

- 1 Loosen the air vent cock on the fuel injection pump by rotating about 1.5 turns.
- 2 Move the priming pump cap up and down repeatedly. When there are no air bubbles in the fuel flowing from the air vent cock, press down the priming pump cap and turn the cap clockwise.
- 3 Tighten the air vent cock on the fuel injection pump.

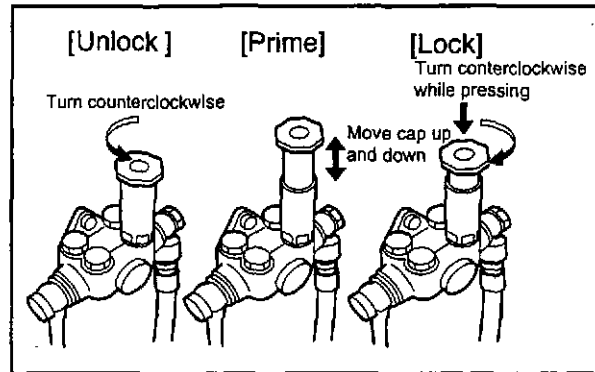

fig.3-1 Using the priming pump

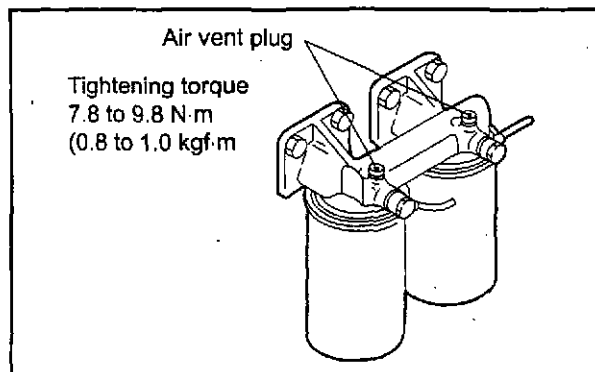

fig.3-2 Fuel filters

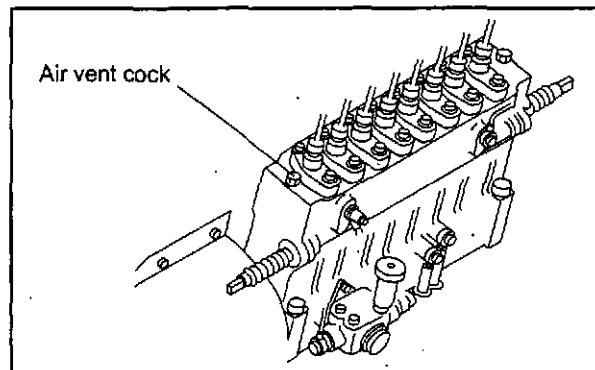

fig.3-3 Fuel injection pump

Priming pump cap tightening method

- 1 Turn the priming pump cap by hand until the force required to turn the cap increases suddenly.
- 2 With the cap at the position described above, place a mark on the cap.
- 3 Then, use a wrench or another appropriate tool to tighten the priming pump cap $90 \pm 10^\circ$.
- 4 Check the cap to make sure that the head packing is not protruding.

Note: If the head packing is protruding, loosen the priming pump cap, check the packing to make sure it is not damaged, then retighten the priming pump cap.

If the head packing is damaged, the priming pump or feed pump must be replaced. Contact a Mitsubishi dealer.

CAUTION

If the priming pump cap is not tightened firmly, internal threads can wear quickly due to friction caused by engine vibrations, resulting in sudden ejection of the priming pump cap to cause a fuel spill.

On the other hand, if the priming pump cap is tightened with excessive force (turned 120° or more), the head of the priming pump can become damaged.

To prevent such problems, be sure to turn the cap the specified angle ($90 \pm 10^\circ$).

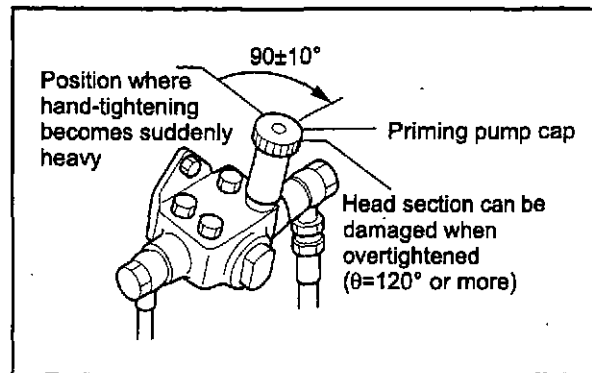

fig.3-4 Priming pump cap tightening method

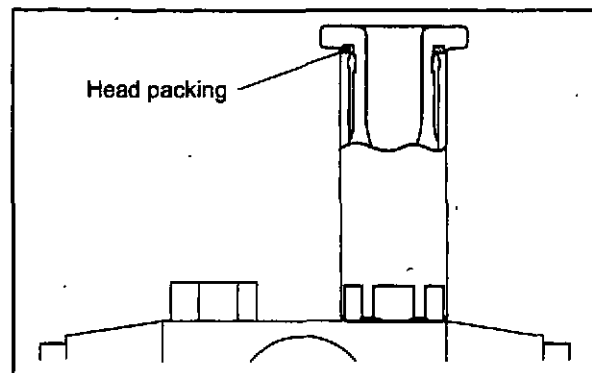

fig.3-5 Priming pump cap packing

Lubricating System

Pouring engine oil

- 1 Remove the cap from the oil filler located on the left side of the engine.
- 2 Pour engine oil of the specified type.

Specified engine oil: Class CD or CF
(API Service Classification)

Engine oil capacity

Oil pan: 200 L [52.84 U.S. gal.]
(entire engine: 250 L [66.05 U.S. gal.])

Note: Regarding engine oil, refer to "Engine Oil" (4-4).

- 3 Check the oil pan and other parts for oil leaks. Repair any oil leakage found.
- 4 Operate the engine oil priming pump to circulate oil in the engine.
- 5 Remove the rocker cover, and make sure that oil is supplied to the valve mechanisms.
- 6 Stop the priming pump. After about 30 minutes, add engine oil until the oil level reaches the Maximum line on the oil level gage.
- 7 Reinstall the cap on the oil filler.
- 8 The oil level should be between the MAXIMUM and MINIMUM marks on the oil level gage. If the oil level is low, add engine oil of the specified type.
- 9 Check the oil pan and other parts for oil leaks. Repair any oil leakage found.
- 10 Crank the engine for about 10 seconds or less using the starters, and wait for about 1 minute. Repeat the above cranking operation several times to circulate oil throughout the engine.

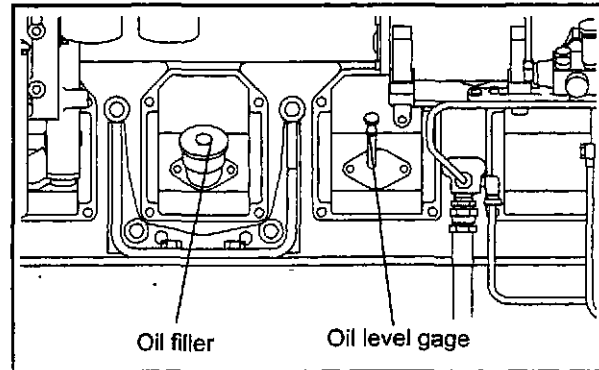

fig.3-6 Oil filler and oil level gage

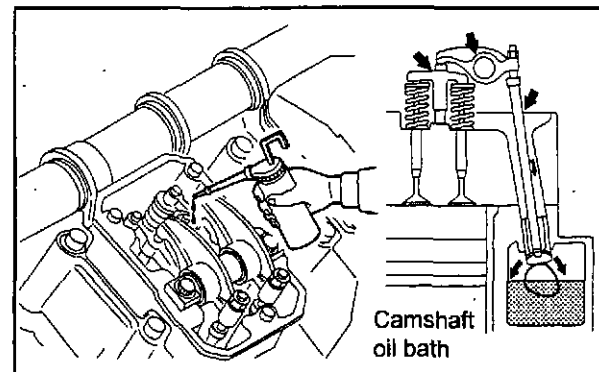

fig.3-7 Pouring engine oil on valve mechanisms and chamber

CAUTION

To crank the engine, shut off the fuel supply to the engine (keep the control rack of the fuel injection pump in the OFF position) and operate the starters.

When conducting the above cranking operation, also check the items to be inspected for the cooling system by cranking.

- 11 Check the oil level with the oil level gage again, and add oil if necessary.

Cooling System

Pouring coolant

1 Make sure the drain cocks on the engine and water pump are closed firmly.

2 Remove the radiator cap, and pour undiluted LLC.

Note: Determine the amounts of LLC and water to be poured by using the LLC concentration chart.

Regarding coolant, refer to "Coolant and LLC" (4-9).

Regarding engine oil capacity, refer to "Main Specifications" (10-1).

3 Pour water (soft water with minimal impurities, such as tap water) slowly to the full level.

Note: For thorough removal of air, loosen the air vent cocks on the upper sections of the air cooler water pipes (right and left).

4 Check the radiator and other parts for coolant leaks. If coolant leakage is found, repair.

5 When coolant reaches the full level, close the radiator cap securely.

6 Crank the engine for about 10 seconds or less using the starters.

7 Wait for about 1 minute, then repeat the above cranking operation several times to remove air from the water pump.

CAUTION

To crank the engine, shut off the fuel supply to the engine (keep the control rack of the fuel injection pump in the OFF position) and operate the starters. When conducting the above cranking operation, also check the items to be inspected for the lubricating system by cranking.

8 Check the coolant level in the radiator.

9 When the reserve tank is installed, pour coolant to the [FULL] level.

Note: Always add coolant having the same LLC concentration.

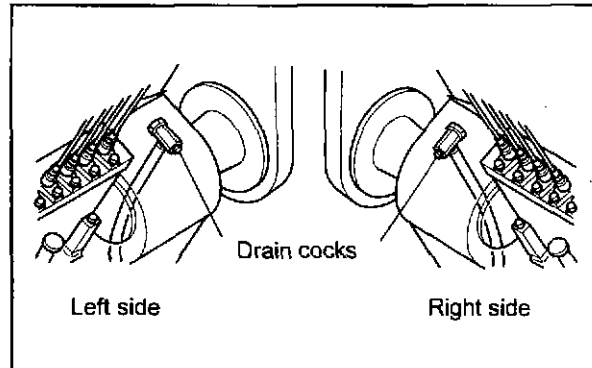

fig.3-8 Coolant drain cock on the engine

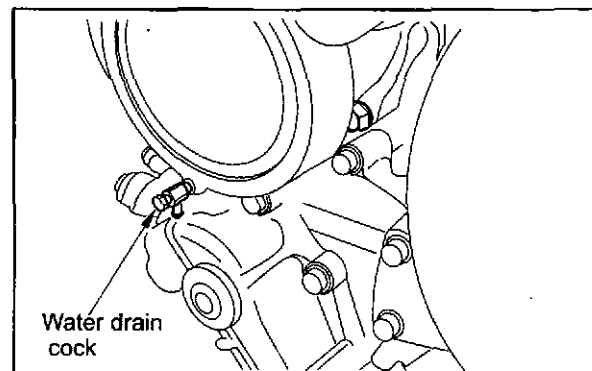

fig.3-9 Coolant drain cock on the water pump

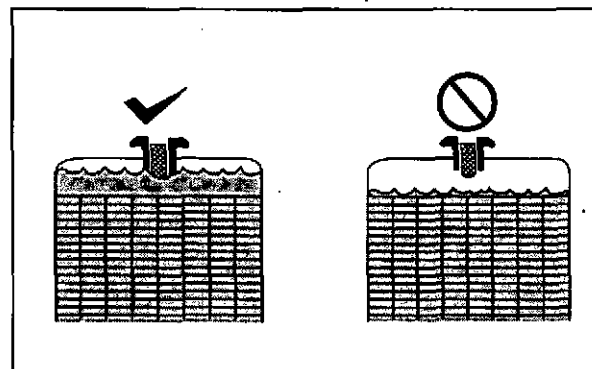

fig.3-10 Radiator coolant level

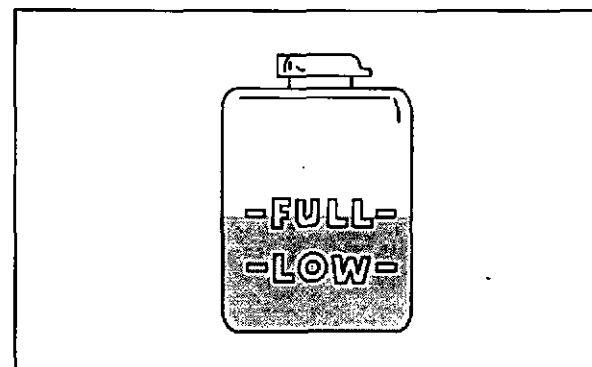

fig.3-11 Coolant level in reserve tank

Checking Battery

⚠ WARNING

If electrolyte is spilled on the eyes, skin or clothes, wash immediately with plenty of water. If electrolyte enters the eyes, flush immediately with lots of fresh water and see a physician.

Do not use flames near the battery. When handling the battery, be careful of sparks generated by accidental shorting.

Regarding other cautions in handling the battery, refer to "Caution Service Battery" (1-5).

Electrolyte level

Electrolyte evaporates during use and the fluid level gradually decreases. The fluid surface should be between the LOWER LEVEL and UPPER LEVEL lines. If there are no level lines on the battery, make sure that the fluid surface is about 10 to 15 mm [0.394 to 0.591 in.] above the top edges of the plate. If the fluid level is lower, remove the caps and add distilled water to the proper level.

Note: When pouring fresh electrolyte, pour the fluid carefully.

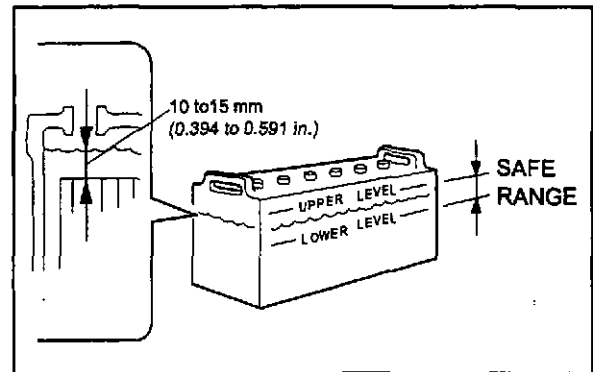

fig.3-12 Inspecting electrolyte level

Checking specific gravity of electrolyte

Check the specific gravity of the electrolyte. If the specific gravity measured at 20 °C [68 °F] is lower than 1.22, then charge the battery.

Table 3-1 Specific gravity of electrolyte

Specific gravity at 20°C [68°F]	Condition	Remedy
From 1.26 to 1.28	Fully charged	-
From 1.22 to 1.26	Charged	Charge
Less than 1.22	Discharged	Charge

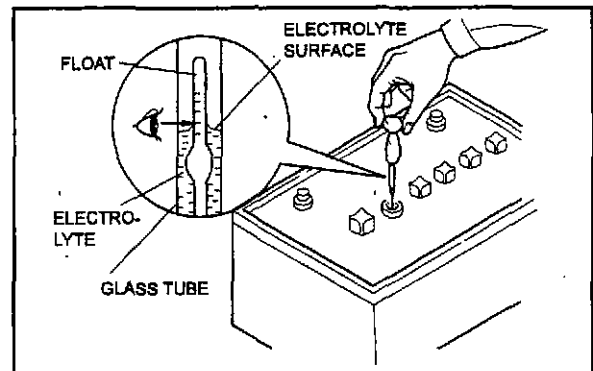

fig.3-13 Inspecting specific gravity of electrolyte

Test Operation

To conduct a test operation, follow the procedures below.

Note: Refer to "Normal Engine Operation" (3-8) to operate the engine.

Starting and stopping

- 1 Start the engine.
- 2 Operate the engine at low idling speed (600 to 650 min⁻¹) under no load for 5 to 10 minutes for a warm-up operation.
- 3 Stop the engine.

Inspection

- 1 Do not operate the engine for 30 minutes.
- 2 During this period, check the engine and surrounding area for leakage of fuel, engine oil and coolant.
- 3 After the engine remains non-operative for 30 minutes, check the oil level with the oil level gage.
- 4 If the oil level is low, add engine oil of the same brand and type through the oil filler.
- 5 Open the expansion tank cap, and check the coolant level.

CAUTION

Remove the expansion tank cap only after the engine cools to room temperature. Place a cloth over the cap, and turn the cap about a half turn to release internal pressure. Opening the expansion tank cap while the engine is hot causes steam and hot coolant to spray out, resulting in skin burns.

- 6 If the coolant level is low, add coolant to the specified level.

CAUTION

Always add coolant having the same LLC concentration.

- 7 When the reserve tank is installed, pour coolant to the [FULL] level.

Normal Engine Operation

The following describes the procedures for operating the engine in normal operating condition.

▲ CAUTION

Should an engine abnormality be observed during operation, stop the engine and correct the problem, or contact a Mitsubishi dealer.

Preparations for Operation (Pre-Start Inspection)

Always conduct the following inspection before starting the engine.

External Inspection

▲ CAUTION

A fire can be caused by combustible materials placed near hot engine parts (exhaust manifolds and other exhaust gas passages) or battery, fuel leaks, and oil leaks. Check the engine exterior carefully. If an abnormality is found, be sure to repair or contact a Mitsubishi dealer.

Before starting the engine, clean the top surface of the battery with wet cloth.

Inspect the engine exterior as described below.

1 Make sure there is no combustible material near the engine or battery. Also, check to make sure the engine and battery are clean.

If combustible materials or waste are found near the engine or battery, remove them.

2 Check the entire engine for leakage of fuel, engine oil coolant. If leaks are found, repair leakage or contact a Mitsubishi dealer.

3 Check the electrical wiring including the starters and alternator.

4 Make sure the following valves, plugs and cocks are open or closed properly:

- Fuel feed valve..... Open
- Coolant drain cock (plug) Closed
- Oil drain valve Closed
- Air supply valve (air tank)..... Open

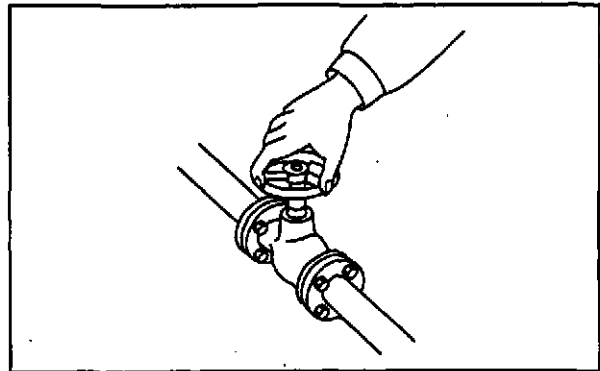

fig.3-14 Checking valves for open/closed position

Draining Water from Fuel Tank

WARNING

When handling fuel, make sure there are no flames or heat source in the area.
Wipe any spilled fuel completely. Spilled fuel can ignite and cause fire.

CAUTION

Do not remove the strainer when filling the fuel tank.
Use fuel specified in "Fuel" (4-2).

Fuel mixed with water and/or dust not only reduces the output but can also cause malfunctions of the fuel system. Drain water from the fuel tank by following procedures below.

- 1 Place a fuel receiving tray (capacity: 2 L [0.53 U. S. gal] or more) under the drain cock on the fuel tank.
- 2 Open the drain cock on the fuel tank, and drain at least 1 to 2 L [0.26 to 0.53 U. S. gal] of fuel.
- 3 Make sure water and dust particles were drained together with fuel, then close the drain cock.

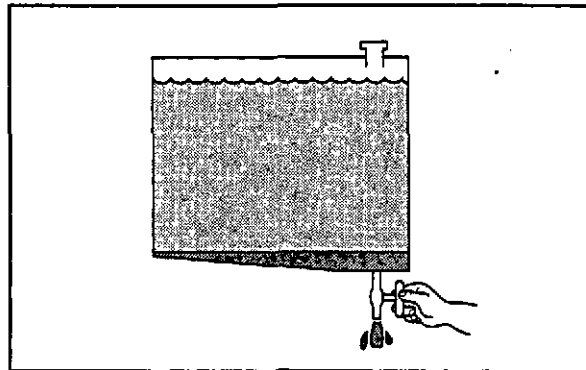

fig.3-15 Draining water from fuel tank

Checking Engine Oil Level

- 1 Check the oil level in the oil pan.
- 2 Pull out the oil level gage and wipe it with a cloth.
- 3 Insert the oil level gage fully into the oil level gage guide, then pull out the gage again.
- 4 The oil level should be between the MAXIMUM and MINIMUM marks on the oil level gage.
- 5 If the oil level is low, add engine oil of the specified type through the oil filler.
- 6 Check the oil pan and other parts for oil leakage.

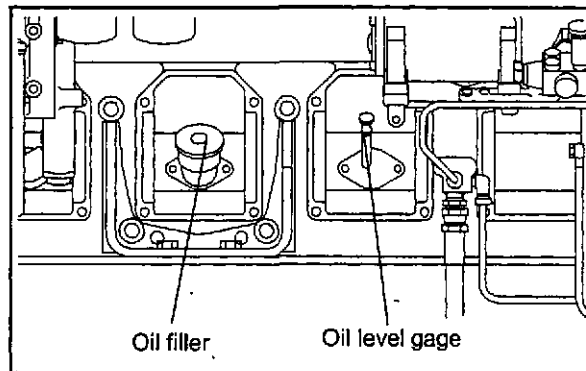

fig.3-16 Oil filler and oil level gage

Checking Coolant Level

Remove the radiator cap only after the engine cools to room temperature. Place a cloth over the cap, and turn the cap about a half turn or stand the lever to upright position to release internal pressure. Opening the radiator cap while the engine is hot causes steam and hot coolant to spray out, resulting in skin burns.

- 1 Open the radiator cap and check the coolant level.
- 2 If the coolant level is low, add coolant to the specified level.

CAUTION

Always add coolant having the same LLC concentration.

Note: Determine the amounts of LLC and water to be poured by using the LLC concentration chart. Regarding coolant, refer to "Coolant and LLC" (4-9).

- 3 If the reserve tank is installed, pour coolant to the reserve tank up to the [FULL] line.

Checking Fuel Control Link

Check fuel control link for smooth movement. Also check ball joint for looseness and play.

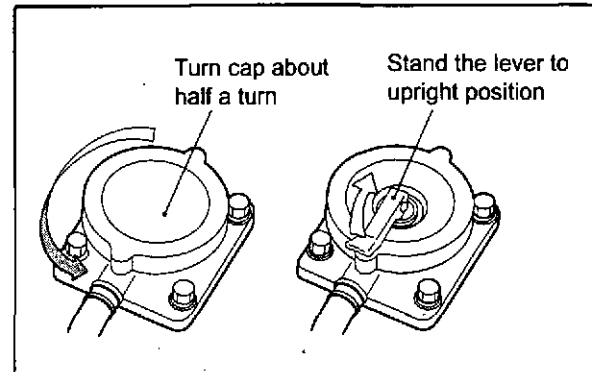

fig.3-16 Radiator cap

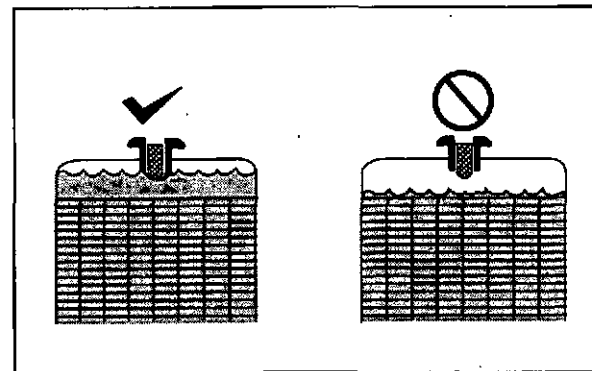

fig.3-17 Radiator coolant level

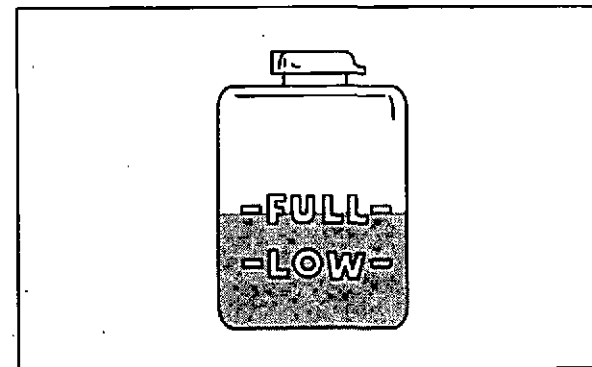

fig.3-18 Reserve tank coolant level

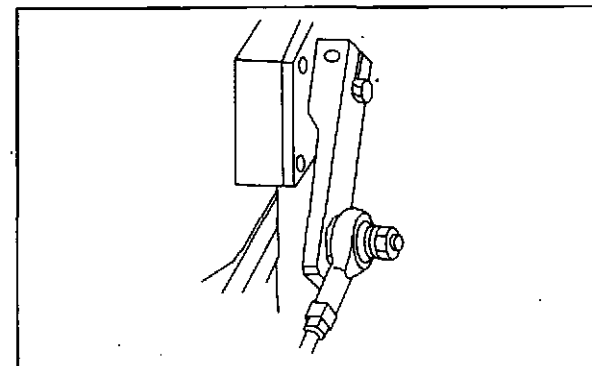

fig.3-19 Checking fuel control link

Inspection of Air Tank Air Pressure

Check the air pressure gage to see if the air pressure in the air tank conforms to the standard.

Air tank internal pressure standard:

2.94 MPa (30 kgf/cm²) [426 psi]

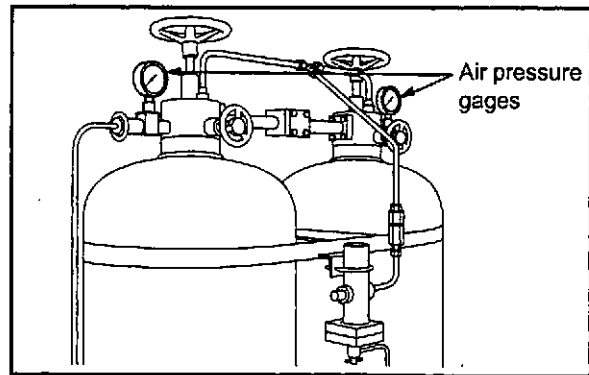

fig.3-21 Inspection of air tank air pressure

Starting

The starting method varies depending on the application and specifications. Start the engine according to the specified procedure.

WARNING

Before starting the engine, check to make sure no one is near the engine and tools are not left on or near the engine. In loud voice, notify people in the area when starting the engine.

CAUTION

Never load the engine at starting time. (Disengage the clutch if it is installed.)

Warming-up Operation

WARNING

Do not approach rotating parts while in operation.

Entanglement by rotating parts can cause serious injury.

CAUTION

Do not conduct warm-up operation for an extended period of time.

Prolonged warm-up operation causes carbon buildup in the cylinders that leads to incomplete combustion.

Do not turn the battery switch to OFF. Turning the battery switch to OFF while the engine is in warm-up operation causes malfunctioning of instruments and deteriorates the diodes and transistors in the alternator.

Never turn the key to START position. If so, starter may be damaged.

During warming-up operation, do not load the engine if exhaust smoke is black. Overloading the engine (indicated by black smoke) not only causes high fuel consumption but also excessive carbon deposits inside the engine, thus it can reduce the service life of the engine.

After the engine starts, operate at no load min. rated speed for 5 to 10 minutes to warm up.

During warming-up operation

During warming-up operation, check if the oil pressure is in the range of standard value.

Also, make sure the oil pressure gage is operating properly.

Note: The oil pressure gage indicates higher pressure than normal immediately after the engine starts since the oil temperature is low. This does not denote an abnormality. The pressure gradually lowers to the normal level as the oil temperature rises.

External inspection during warming-up

Check the external view of the engine to make sure there is no fuel, oil, cooling water or exhaust gas leakage from joints.

Operation

▲ WARNING

Do not approach rotating parts while in operation. Entanglement by rotating parts can cause serious injury.

▲ CAUTION

Do not touch any part of the engine while it is operating or immediately after it is shut down. A hot engine can cause burns.

CAUTION

Provide adequate ventilation in the engine room. If air supplied to the engine room is restricted, the room temperature increases and can affect engine output and performance.

During the first 50 hours of operation, break-in the engine by operating it with light load and at lower speed than normal.

Operating the engine under high load or severe conditions during the break-in period can shorten the service life of the engine.

Do not turn the battery switch to OFF when the engine is in operation. Turning the battery switch to OFF while the engine is in operation not only stops the battery charge but also causes malfunctioning of instruments and deteriorates the diodes and transistors in the alternator.

Never turn the key to the START position while the engine is operating. The starter may be damaged.

After the warm-up operation, start operating the engine with load.

Inspection during operation

Check for leakages.

Inspect the exterior of the engine to make sure there is no leakage from joints.

Check to make sure the engine does not produce abnormal noise or vibrations.

Inspect the engine for abnormal operating sound and vibrations such as knocking.

Check to make sure the exhaust gas is normal color.

Check the color of the exhaust gas discharged from the exhaust pipe.

Note: Regarding abnormal exhaust gas conditions, refer to "Other Problems and Countermeasures" (9-3).

Check to make sure the instruments and gages indicate normal values.

Table 3-2 Data for rated speed

Item	Standard value
Engine oil pressure gage	0.49 to 0.64 MPa (5 to 6.5 kgf/cm ²) [71 to 92 psi]
Coolant temperature	70 to 90.°C [158 to 194 °F]

Note:(a) When the oil pressure drops below 0.29 MPa (3 kgf/cm²) [42.7 psi] in normal operation, or below 0.10 MPa (1 kgf/cm²) [14.2 psi] at minimum speed with no load, stop the engine immediately. Before restarting the engine, check and correct the cause of the problem.

(b) When the high temperature alarm switch is activated in normal operation, change the engine operation immediately to no-load idling (600 min⁻¹) condition until the engine temperature decreases to normal operating level. Then, operate the engine for another 5 or 6 minutes for cooling before stopping the engine. Before restarting the engine, check and correct the cause of the problem.

Stopping

CAUTION

Stopping the engine abruptly while engine parts are hot due to high-speed operation can be a cause for heat up of the engine parts and shorten the service life of the engine. Before stopping the engine, let it operate at low idle speed for 5 to 6 minutes to cool down operation. Stopping the engine immediately after high-speed operation can cause engine parts to be heated up and result in bad effects.

During cooling operation, check the engine for abnormalities.

Do not accelerate the engine prior to shutting it down.

Do not restart the engine immediately after it shuts down due to an abnormality. If an alarm is generated when the engine stops, locate the cause of the problem and correct the problem before restarting the engine.

Continuing engine operation without correcting the problem can result in a serious accident.

For stopping the engine, follow the instructions since stopping procedure varies depending upon the models and its installed equipment.

Emergency Stop

CAUTION

When stopping the engine by pulling the speed control lever, continue pulling the lever until the engine stops completely. If not, the engine may start again

To stop the engine with emergency lever, pull the manual lever to the arrow direction and continue pulling the lever until the engine stops completely.

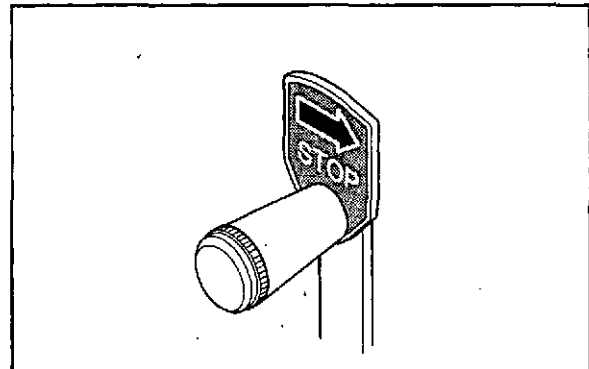

fig.3-22 Manual stop lever

Inspection After Stopping

Inspect the engine parts to make sure there is no fuel, oil or coolant leakage. If a fuel or oil leak is found, repair the leakage or contact a Mitsubishi dealer.

Chapter 4 MAINTENANCE

Cautions concerning maintenance

Stop the engine before checking or adding fuel, oil or coolant

Be sure to stop the engine before checking and adding fuel, engine oil or coolant.

Do not check coolant immediately after the engine stops. Make sure the coolant temperature is sufficiently low when checking coolant.

Never attempt to adjust parts while the engine is in operation.

Failure to follow the above instructions may cause fire, skins burns or entanglement by rotating parts.

Handle battery electrolyte carefully

▲ CAUTION

If battery electrolyte contacts your skin, flush immediately with plenty of water.

If battery electrolyte enters your eyes, flush immediately with plenty of water and seek medical attention at once.

Handle LLC carefully

▲ CAUTION

If LLC is accidentally swallowed, induce vomiting immediately and seek medical attention at once.

If LLC enters your eyes, flush immediately with plenty of water and seek medical attention at once.

LLC is a strong alkaline solution. Do not drink or allow it to contact your eyes.

Always wear protective gear

▲ CAUTION

Wear protective gear such as a hardhat, face shield, work clothes, safety shoes, dust protective mask, etc. Be sure to wear protective goggles and other protective devices when handling compressed air. Compressed air can cause personal injury if it handled carelessly.

Use recommended fuel, engine oil and coolant

CAUTION

Use fuel, engine oil and coolant specified in this manual. Use extreme care when handling.

Perform all pre-start inspections and periodic inspections

CAUTION

Conduct the pre-start inspection and periodic inspection as instructed in this manual.

Failure to conduct pre-start inspections and periodic inspections may cause various engine problems such as damage of parts, and could result in serious accidents in worst case scenario.

Use only genuine mitsubishi parts

CAUTION

When replacing parts with new ones, use only genuine Mitsubishi parts.

To obtain new parts, contact your Mitsubishi dealer.

Fuel

Recommended fuel

Use recommended fuel specified in this manual.

Do not refill fuel tank more than the specified level, as it may result in a fire.

Use fuel that meets the values specified in the table of "Recommended and Limit Values of Fuel Property" (4-3).

Use a diesel oil that meet "JIS K2204, Diesel Oil" or equivalent.

It is necessary to use fuel that has a pour point suitable for the ambient temperature. Choose the fuel type from the chart on the right.

Table 4-1 Recommended Fuel

Standard	Classification
JIS K2204	TYPE 1, TYPE 2, TYPE 3
ASTM D975	No. 1-D, No. 2-D
BS 2869	CLASS-A1, CLASS A-2
DIN 51601	DIESEL-FUEL
ISO 8217	DMX-CLASS

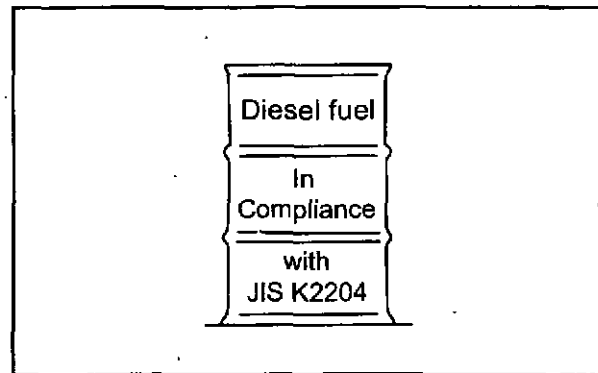

Fig.4-1 Recommended fuel

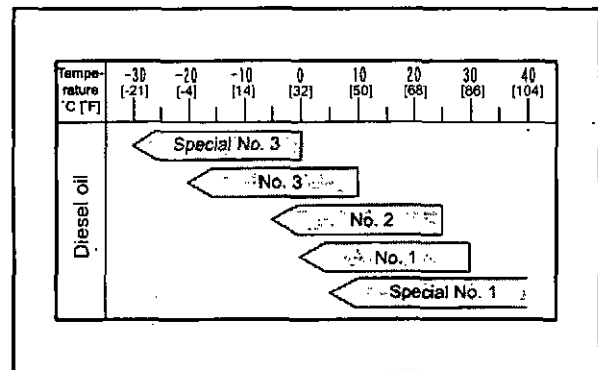

Fig.4-2 Recommended fuel according to air temperature

Handling fuel

When using fuel in a storage tank, leave it to sit for more than 24 hours so that dust and water can settle at the bottom. Then, use the upper clean fuel.

Fill up the fuel tank or service tank at the end of each day of operation. This prevents water from mixing with fuel in the tank and also gives time for dust and water to separate and settle at the bottom of the tank.

Before refilling, clean the areas around the caps thoroughly and remove the caps from the drum and tank. Also clean your hands and the hose before refueling. When using a hand-operated pump, be careful not to pump water or sediment accumulated at the bottom of the storage tank.

Be sure to use a strainer when filling fuel tank. For a complete filtration, it is recommended to use of a clean lint-free cloth together with the strainer.

Table 4-2 Recommended and limit values of fuel property

Property		Limit value	Remarks	Recommend value
Flash point		As stipulated by regulation	As stipulated by regulation	JIS K2204, 2205 Diesel fuel: 50°C or higher Class-A heavy oil: 60°C [140°F] or higher
Distillation	Initial boiling point	170°C [338°F] or higher	170°C [338°F] or higher	JIS K2254
	90% boiling point	330 to 380°C [626 to 716°F]	330 to 380°C [626 to 716°F]	
Pour point		6°C [10.8°F] or more below ambient temperature		JIS K2269
Cloud point		Ambient temperature or below		
Carbon residue (10% residual oil)		0.4 weight % or lower	1.0 weight % or lower	JIS K2270
Cetane number		45 or higher	45 or higher	
Cetane index (new)		45 or higher	45 or higher	JIS K2280-1996
Kinetic viscosity		2.0 mm ² /s [0.0031 in ²] or higher (30°C [86°F]) 8.0 mm ² /s [0.0124 in ²] or lower (50°C [122°F]) 10.5 mm ² /s [0.0163 in ²] or lower (40°C [104°F]) 16.0 mm ² /s [0.0248 in ²] or lower (30°C [86°F])		
Sulfur content		0.2 weight % or lower	1.0 weight % or lower	JISK25410.05 weight % (same as diesel fuel) is recommended.
Water and sediment		0.1 volume % or lower	0.1 volume % or lower	JIS K2275
Ash		0.03 weight % or lower	0.03 weight % or lower	JIS K2272
Copper plate corrosion (100°C [212°F], 3 hrs.)		No.3 or lower	No.3 or lower	ASTM - No.3 JIS K2513 - Discoloration No.3
Specific gravity (15°C [59°F])		0.83 to 0.87	0.80 to 0.87	
Coking test		Should not be carbonized more than 75% at 250°C [482°F]	Should not be carbonized 100% at 250°C [482°F]	Fed791B (U.S.) 250°C [482°F]x24Hr 230°C [446°F]x24Hr 180°C [356°F]x48Hr
		Should not be evaporated more than 55% at 230°C [446°F]		
		Should not be turn to tar at 180°C [356°F]		
Aromatics content (HPLC method)		38 weight % or lower	38 weight % or lower	JIS K 2536 Total of aromatic content
Asphaltene		0.1 weight % or lower	0.1 weight % or lower	ICP analysis (U.K.)
Particulate contaminant		5.0 mg / l or lower	5.0 mg / l or lower	JIS B9931 Including foreign substances in the fuel pipe lines

Engine oils

Properties of engine oils and their influence on engine performance

Engine oil plays a role of lubrication of engine and has a great influence on the performance and durability of engine

Distinctive differences of engine oil from other oils are that engine oil lubricates hot sections adjacent to the combustion chamber and is strongly affected by the combustion products. Engine oils, therefore, are required to have cooling, sealing, deterging, and neutralizing abilities in addition to the lubricating function. Because diesel engines especially produce acid products such as sulfuric acid due to sulfur content of fuel and soot due to imperfect combustion that contaminates oils, engine oils for diesel engines must have capabilities not only to withstand severe lubricating conditions, but also to neutralize acids products to prevent them from agglomeration and deposition. The function of performance required for engine oils is shown below:

- Good detergent dispersability for at high temperature application for the prevention of contamination and deposition of sludge and soot.
- Excellent acid neutralizing capability to inhibit oxidation due to sulfur content of fuel.
- Good oxidation stability that withstands the long hours at high temperature.
- Appropriate viscosity to maintain lubricity and low-temperature startability.
- Good rust and corrosion resistance to water.
- Good foam resistance to prevent the lubricating quality from lowering due the oxidation.

Main properties of engine oils

Dispersibility

Engine oil performance degrades through the oxidation and also by external causes. Acid products such as sulfuric acid due to sulfur content of fuel become insoluble sludge. Incomplete combustion of fuel creates soot in oil.

Those sludge and soot in oil are accumulated in the groove or on inner surface of piston ring and will result in seizure or wear of piston ring, or it will lower heat transfer of piston ring drastically. Dispersibility of engine oil is to disperse sludge and soot in oil in order to prevent from the deposition.

Acid neutralization ability

Compared to gasoline fuel, diesel oil or A-fuel oil produces more sulfuric acid due to high sulfur content in fuel during combustion, and the sulfuric acid contaminates the oil. To neutralize the sulfuric acid, engine oils are required to have an excellent neutralizing ability. Engine oils for diesel engines usually contain a detergent metal agent that has high neutralization ability.

Viscosity

Viscosity is the measure of oil's resistance to flow. In general, the viscosity of a simple liquid decreases with increasing temperature and vice versa. This characteristic of viscosity directly relates to low-temperature startability, lubricity, fuel consumption by friction loss, and oil consumption.

For identification of an oil's viscosity, SAE (Society Automotive Engineers) numbers are widely used. (The viscosity of engine oil identified by the number of SAE shows thick and thin of viscosity at particular temperature.)

The characteristics of engine oils are identified not only by viscosity number that shows thick and thin of viscosity at particular temperature, but also by viscosity index that shows the changes in oil viscosity with changes in temperature. When viscosity index of oil is high, which means the change of viscosity due to temperature is small.

Viscosity index (VI)-100 of oil is generally used for application of diesel engine. Oils indicated by, for instance, VI-100 is called single grade oil, which falls under one range of viscosity. There is also oils that called multigrade oil which viscosity fall under two range of viscosity and they are indicated by, for instance, SAE 15W-40, which means that at lower temperature, oil has 15W grade, and also has 40 grade at higher temperature. ("W" indicates the suitability of oil for colder temperature). In other word, 15W-40 indicated by oil demonstrates SAW15 grade of viscosity at lower temperature and 40 grade viscosity at higher temperature.

Recommended engine oil

CAUTION

Use only recommended engine oils in this manual. Never use other oils. The use of inappropriate or inferior oils will result in sticking of piston ring, seizure between piston and cylinder, or premature wear of bearings and moving parts, and significantly shortens the service life of engine.

Many oil standards, which established through special engine tests, are available to determine the quality of oil depending application of engines and operating conditions. Among those standards, SAE viscosity grades and API (American Petroleum Institute) service classifications are mostly used to classify engine oils. SAE specifies the viscosity only while API service classification indicates quality level of engine oil. Seven grades from CA to CF-4 are provided for diesel engine oil. For Mitsubishi diesel engine, CD or CF graded oils is recommended as they are suitable for supercharging and high load application.

In addition, CE grade oil is established for the use with fuel of 0.5 % sulfur content or less and CF-4 for the use of fuel of 0.2% sulfur content or less. Thus when using A-fuel oil that often has 0.5% sulfur content or above, do not use CE or CF-4 graded oil.

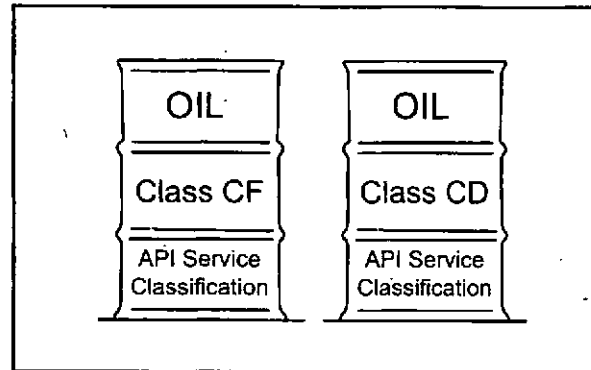

Fig.4-3 Recommended engine oil

Selection of oil viscosity

Use the following chart to select the appropriate oil viscosity according to the ambient temperature. Excessively high oil viscosity causes power loss and an abnormal rise of oil temperature, while excessively low oil viscosity accelerates wear due to inadequate lubrication, and also causes a decrease in engine output due to leakage of combustion gas.

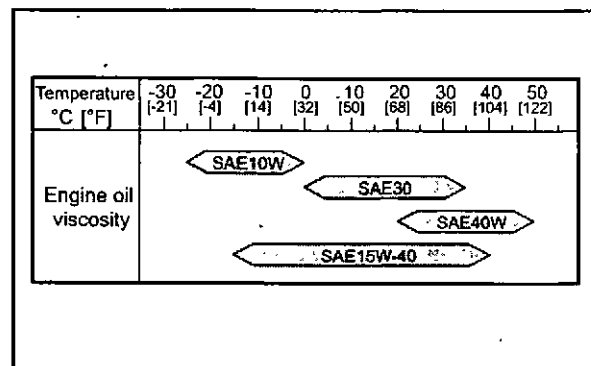

Fig.4-4 Recommended oil viscosity according to air temperature

Genuine engine oil

Mitsubishi Heavy Industries, Ltd. offers the best suited oils, which yielded from many tests, to Mitsubishi diesel engines. We highly recommend the use of our genuine engine oil. For land use engine, "JUKOIL Cojera 15W-40 or 15W-30" and for marine engine, "JUKOIL New Mariner 15W-40 or 15W-30" are available.

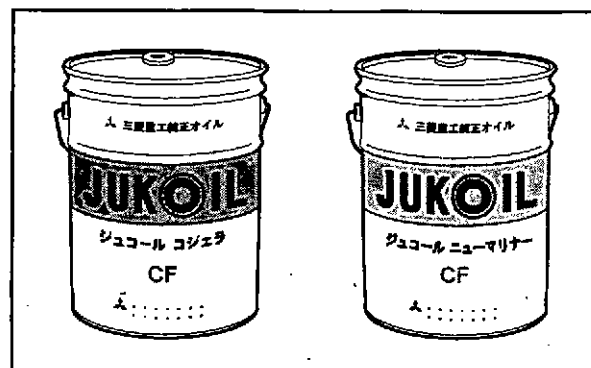

Fig.4-5 Jukoil cojera, new mariner

Engine oils in the market

Mitsubishi Heavy Industries, Ltd. does not warrant the engine if oils in the market are used.

The quality and performance of commercially available oils as well as their components variations are in the responsibility of engine oil suppliers. Before purchasing commercial oils, be sure to discuss the suitability of engine oil with the oil supplier.

Handling engine oil

Before filling engine with engine oil, stop the engine and make sure there are no open flames and other fire hazards near the engine. Leaked or spilled oil on hot surfaces or electrical components can cause a fire. Wipe off any spilled oil immediately and thoroughly. After filling, securely close the filler cap.

CAUTION

Never mix different brands of engine oil. Mixing different brands of engine oil may cause a chemical reaction by additives in the engine oil that could degrade the engine oil quality.

When handling oil of more than the legally specified quantities, be sure to have the work performed by a service station in compliance with the legal regulations.

When removing oil from the engine or oil can, use an oil pump. Do not suck oil with the mouth to siphon.

Be sure to close the cap on the oil can after use.

Keep oil in a well-ventilated place and out of direct sunlight.

Be sure to obtain the MSDS (material safety data sheet) of the engine oil used and follow the instructions of the MSDS.

Service limits of engine oil

Engine oil degrades by the use and by lapse of time.

Be sure to renew engine oil if a property exceeds the limit.

Table 4-3 Service Limit for Engine Oil Properties

Propertie		Service limit	Test Method
Viscosity	cst@ 100C	Within +30 and -15% of new oil	JIS K2283
Total base number	mgKOH/g	2.0 or more with hydrochloric acid (HCL) method 1/2 of new oil or more with perchloric acid (PCA) method	JIS K2501
Total acid number	mgKOH/g	Up to +3.0 of new oil	JIS K2501
Water content	Vol %	0.2 or less	JIS K2501
Flash point (open cup)	°C	180 or more	JIK K2275
Pentane insolubles	Wt %	0.5 or less	Comply with ASTM D893
Pentane insolubles coagulated	Wt %	3.0 or less	Comply with ASTM D893

Definition of properties of engine oil

Viscosity

Viscosity is a basic physical property of engine and considered as the most important aspect of oil when evaluating.

Contamination of oil by blow-by gas and deterioration of oil by its natural aging degrade the performance of viscosity that will cause the deposition of sludge in the interval engine and oil filter clogging. Contamination of oil by fuel and sheared molecules of viscosity index improver in oil also degrade the performance of viscosity that will cause insufficient lubrication and friction/wear of engine parts.

Total base number

Total base number (TBN) shows the ability to neutralize acids such as organic acid due to the engine oil oxidation, or sulfurous acid or sulfuric acid due to sulfur content of fuel.

Because TBN indicates the amount of dispersant detergent in oil, it can be used to estimate consumption of basic dispersant detergent. The ability to disperse sludge declines as dispersant detergent is being used up.

Total acid number

Total acid number in oil increases as the organic acid is being derived by the engine oil oxidation, or sulfurous acid or sulfuric acid derived by the combustion of sulfur content of fuel, or the oil is contaminated with imperfect combustion products. The increase of total

acid number will result in corrosion or wear of inner parts of engine (such as cylinder liner or metals) derived by sulfur content, and piston ring seizure by sludge.

Water

Water in oil promotes corrosion/wear, and decreases lubricity in sliding parts.

Flash point

Flash point is lowered by contamination by fuels. Flash point is measured to check the dilution of fuel. The dilution of fuel reduces oil film, and causes insufficient lubrication that will cause friction or wear of engine parts.

Insolubles

Insolubles include acid products of engine oil, imperfect combustion products, sludge or soot, metal abrasive particles and dust. Insolubles are an indication of degradation/contamination of oil.

Dispersant detergent, which is one of additives in engine oil, absorbs sludge particles, and disperses them as fine particles in oil.

Total insolubles density and remaining dispersibility can be obtained by measuring insolubles and coagulated insolubles (using chemical specialities to stop action of disperse detergent and to collect the sludge dispersed in oil) and by which, piston ring seizure or premature wear can be prevented before occurring.

Engine oil analysis service

For a long term service life of engine, Mitsubishi Heavy Industries, Ltd. offers an engine oil analysis service. The service includes special oil sampling tools, the sample oil analysis and the result data.

The engine oil analysis service provides the following information:

- The quantity of fine metal powder in engine oil due to abrasion, by which worn parts can be located.
- Water, LLC, or salt that should not be in engine oil can be detected.
- Engine oil deteriorating conditions, with that, appropriate engine oil renewal intervals, operating conditions, proper inspection and maintenance schedule can be planned.

The engine oil analysis service can diagnose the internal condition of an engine, which used to require engine disassembly. It is highly recommended to take advantage of our engine oil analysis service as you can learn the engine condition before any malfunctions are appeared on the engine.

How to order engine oil sampling tool set

The oil sampling pump is reusable, but oil sampling bottle and suction pipe must be replaced each time. For replacing tools, order them through the regular part supply system. The analysis fee is included in the price of the sampling bottle. Therefore, if you sample the oil in other bottles, you will not receive our analysis service. Also, note that *optional analysis requires addition charge.*

Table 4-4 Engine oil sampling tool sets

Product name	Part no.	Remarks
Engine oil sampling set	36291-19100	Contains oil sampling pump, pipes and bottles
Oil sample bottle set	36291-00098	1 Carton: 6 bottles Includes suction pipes and oil sample data labels

Oil sampling bottle set: 1 carton: 6 bottles includes suction pipes and analyzing data of sample oil

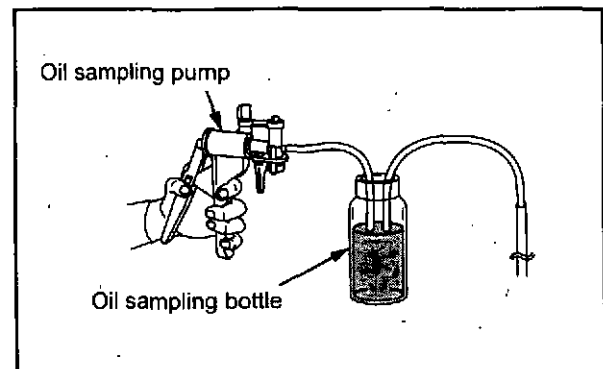

Fig.4-6 Engine oil sampling tool set

Coolant and LLC

Recommended coolant

Use soft water (e.g. tap water) for the engine cooling system. The water quality must meet the requirements in the Table below. Basically, the water quality should be within the recommended value, however, within limit is acceptable.

Table 4-5 Water quality standards

Item	Chemical symbol	Unit	Recommended	Limit	Main adverse effect	
					Corrosion and rust	Scale formation
pH (25°C [77°F])	-	-	6.5 to 8.0	6.5 to 8.5	○	○
Electrical conductivity (25°C [77°F])	-	mS/m	<25	<40	○	○
Total hardness	CaCO ₃	ppm	<95	<100	-	○
M alkalinity	CaCO ₃	ppm	<70	<150	-	○
Chlorine ion	Cl	ppm	<100	<100	○	-
Sulfuric acid ion	SO ₄ ²⁻	ppm	<50	<100	○	-
Total iron	Fe	ppm	<1.0	<1.0	-	○
Silica	SiO ₂	ppm	-	<50	-	○
Residue from evaporation	-	ppm	<250	<400	-	○

Note: Figures in parentheses are the standard value. In addition to the items specified above, turbidity is specified to be below 15 mg/liter.

Long life coolant (LLC)

⚠ CAUTION

LLC is TOXIC. If LLC is accidentally swallowed, induce vomiting immediately and seek medical attention at once. In case of contact with your eyes, flush immediately with plenty of water and seek medical attention at once.

Use an all-season, non-amine type LLC.

Do not use antifreeze solution that prevents only freezing. Be sure to use long life coolant (LLC) as coolant, because it prevents not only freezing of coolant but also rusting of the cooling system.

Genuine LLC

Mitsubishi Heavy Industries, Ltd. recommends the use of our genuine long life coolant "GLASSY," which is the most appropriate coolant for Mitsubishi diesel engine.

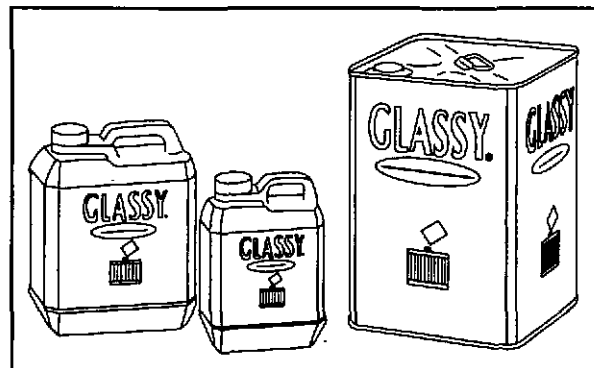

Fig.4-7 GLASSY - LLC

LLC in the market

CAUTION

Never mix Mitsubishi genuine LLC with other brand LLC. Mixing with other brand LLC degrades the performance of the genuine LLC

Mitsubishi Heavy Industries, Ltd. does not warrant the engine if LLC of other brand is used. The quality and performance of commercially available LLCs as well as their components variations are in the responsibility of LLC suppliers. Before purchasing commercial LLC, be sure to discuss the suitability of LLC with the LLC supplier.

Use only all-season LLC (non-amine type). Do not use antifreeze alone instead of LLC.

Maintenance of LLC

CAUTION

LLC is toxic. Never dispose of coolant containing LLC drained from engine into regular sewage. For disposal of used coolant, consult your Mitsubishi dealer.

Replacement intervals of LLC

CAUTION

Be sure to renew LLC (coolant) at the specified intervals in this manual. Failure to renew LLC may cause malfunctions due to cavitation

The coolant containing LLC recommended in this manual should be renewed every 8000 hours or 2 years, whichever comes first, for a regular-use or general-purpose engine. For an emergency-use engine, renew coolant every 2 years.

LLC concentration

When determining the LLC concentration, provide a margin of 5°C [9°F] below the expected lowest temperature in your region. Maintain the LLC concentration between 30 and 60% throughout the year.

LLC of less than 30% concentration does not provide sufficient corrosion protection. If the LLC concentration is as low as several percent, it may accelerate corrosion. LLC of more than 60% concentration can adversely affect its freeze protection characteristic and cause the engine to overheat easily.

When adding coolant, do not add plain water. Always use coolant having the same LLC concentration.

Table 4-6 Recommended LLC concentration
(for reference only)

Lowest ambient temperature °C [°F]	up to -15 [5]	up to -24 [-11]	up to -36 [-32]	up to -43 [-45]
LLC concentration (%)	30	40	50	55

Note: The concentration above is based on the Mitsubishi genuine GLASSY long life coolant.

For determining the accurate LLC concentration, refer to the instructions for the LLC used.

Importance of LLC

Today's trend is toward smaller and more lightweight engines offering greater output, lower fuel consumption and lower exhaust emission level.

Conditions to which engine coolant is subjected, therefore, are becoming severer due to longer operating hours, higher coolant temperature and higher coolant circulating speed.

Many different materials such as steel, aluminum, copper, solder and rubber are used in the cooling system, and they are also subjected to the severe conditions described above.

Those materials have different ionization characteristics, and this difference accelerates corrosion through the medium of engine coolant.

To prevent such a problem, the use of LLC (long life coolant) is very important.

Characteristics of LLC additive and important notes

LLC contains several chemicals in such proportions as to produce chemical reactions that suppress corrosion (ionization) of engine parts in contact with the coolant.

LLC loses its effectiveness by hours of use as well as lapse of time.

Moreover, if the chemicals are not well proportioned to match the metals used in the cooling system, certain chemicals in the LLC become rapidly used up and result in dissolution of metals instead of protecting metals from corrosion.

Consequently, other corrosion preventing chemicals react with dissolving metals and accelerate corrosion. This condition generates more severe corrosion than when plain soft water is used. This is a typical problem caused by the use of inappropriate LLC.

Examples of abnormalities caused by LLC

Pitting on iron parts

Amines are generally effective in suppressing the rusting of ferrous metals, but they are said to cause problems for copper parts.

Dissolved copper (copper corrosion) in the cooling system deposits on iron parts and the copper deposits cause a corrosion and then pitting on iron parts that has a high ionization characteristics due to galvanic or local-cell action.

Corrosion of aluminum parts

Silicate is highly effective in protecting aluminum against rusting. However, it is unstable in a solution in which pH is 9 or lower, and can turn to gel and precipitate in the solution. For this reason, the pH is usually specified to be about 10 to ensure a high alkaline level.

This means, after silicate is used up, the high alkalinity causes chemical attacks on aluminum. To prevent this problem, proper maintenance of the coolant is required.

(Example)

Rapid wear of mechanical seals in the water pump due to secondary effects of silicate gel formed.

Corrosion of aluminum parts after silicate is consumed.

Pitting and clogging of radiator

When LLC deteriorates or when its concentration in the coolant is too low, the anti-corrosion performance of LLC lowers and results in the corrosion of metals.

Brass and solder tend to corrode faster than other metals, and corrosion of these metals is said to cause water leakage and clogs.

(Example)

Holes and clogs in radiator

Filters

Do not use the filter that has dent on its case.

It may damage the filter, or may cause fuel/oil leaks, which could result in a fire during operation.

The function of filters is to remove impurities such as dust particles from fuel, engine oil and air starter system. While it is important to provide clean fuel, engine oil and air, filters must be replaced regularly to ensure maximum engine performance and extend the service life of the engine.

When replacing filters, use genuine Mitsubishi parts.

Do not wash and reuse cartridge-type filters.

Always use new filters.

When filters are replaced, check the used and removed filters for metal particles. If metal particles are found, consult your Mitsubishi dealer.

Electrical parts

Do not splash water on electrical parts. Water can cause electrical leakage and short-circuiting and result in equipment damage. Wet electrical parts can also cause electric shock.

When cleaning the engine, keep water away from electrical parts.

If malfunctioning of electrical parts is suspected, consult your Mitsubishi dealer.

Also, do not disassemble nor reassemble electrical parts.

Cautions on operating engine in cold weather season

When the ambient temperature is low, the fuel and engine oil become thick, and the coolant can freeze. As a result, the engine fails to start or the cylinder heads may be damaged. To prevent these problems, observe the following directions.

Fuel

When handling fuel, make sure there are no open flames or other fire hazards near the engine.

Wipe off any spilled fuel completely. Spilled fuel can ignite and cause a fire.

Use appropriate fuel according to the ambient temperature.

Note: For fuel, refer to "Fuel" (4-2).

Engine oil

Use engine oil suitable to the ambient temperature.

Note: For engine oil, refer to "Engine oils" (4-4).

Coolant

▲ CAUTION

Remove the radiator cap only after the engine is cooled to the room temperature. Place a cloth over the cap, and loosen the cap about a half-turn or stand the lever to upright position to release pressure. Opening the radiator cap while the engine is hot causes steam and hot coolant to blow out and result in skin burns.

Freezing of coolant due to cold temperatures can damage the crankcase. Be sure to use all-season long life coolant that prevents freezing of cooling water.

Note: For coolant, refer to "Coolant and LLC" (4-9).

Battery

Do not use open flames near the battery. When handling the battery, be careful of sparks generated by accidental shorting.

▲ CAUTION

If battery electrolyte is spilled on your skin, flush immediately with lots of water. If the electrolyte enters your eyes, flush immediately with lots of fresh water and seek medical attention at once. For other cautions about handling batteries, refer to "Caution Service Battery" (1-5).

When the ambient temperature decreases to a very low level, the charging rate becomes low even if the specific gravity of electrolyte remains the same. Therefore, in a cold area the battery may not provide sufficient power to start the engine. Also battery electrolyte easily freezes when its specific gravity is low. It is, therefore, recommended to additionally charge the battery to increase the specific gravity of electrolyte and the charging rate.

Note: For the inspection of specific gravity of electrolyte, refer to "Checking specific gravity of electrolyte" (6-14).

Maintenance after cold season

When a cold season ends, change fuel, engine oil and coolant to those suitable for the outside temperature in accordance with the specifications described in this manual.

Chapter 5

PERIODIC MAINTENANCE CHART

How to Use Periodic Maintenance Chart

Periodic inspection not only extends the service life of the engine but also serves to ensure safe operation. Be sure to conduct inspections and maintenance according to the periodic maintenance chart. The maintenance chart shows the standard service intervals. Whenever you notice the abnormalities mentioned below, make sure the service must be performed to the defective part of the engine, regardless recommended service intervals in the "Periodic Maintenance Chart"; abnormal noise, black exhaust smoke, white exhaust smoke, abnormally high temperature of exhaust gas, abnormal vibration in engine, fuel, oil or exhaust gas leakage.

Note: Appropriate service intervals vary depending on the usage and operating conditions as well as consumption of fuel, oil and coolant.

Check the operating record of the engine to determine the most appropriate service intervals. (Feel free to consult a Mitsubishi dealer regarding service intervals.)

Perform service items listed under the service interval. Service items with shorter intervals should also be included in the longer interval service.

Items marked with □ in the maintenance chart require special tools or large equipment. For the servicing of these items, consult a Mitsubishi dealer.

Periodic Maintenance Chart

Appropriate service intervals vary depending on the engine specifications. Perform all daily inspection and maintenance items in an accordance with the following 3 categories.

Periodic maintenance chart for regular-use engine

When the engine is used as a regular use engine, perform the periodic inspection and maintenance in accordance with the "Periodic Maintenance Chart for Engine in Regular Use".

Periodic maintenance chart for emergency engine

When the engine is used as an emergency engine, perform the periodic inspection and maintenance in accordance with the "Periodic Maintenance Chart for Emergency Engine".

Due to the nature of application, an emergency engine is subject to demanding operating conditions such as a quick startup and immediate supply of power. In addition, it must operate reliably in the event of an emergency. Therefore, be sure to perform the daily inspection and also conduct the following operation for maintenance purposes.

Once every week: Operate the engine under no load (for 3 to 5 minutes).

(When operating the engine for the adjustment of peripheral devices, limit the operating time to 10 minutes.)

Once every month: Operate the engine under load (for 15 to 30 minutes with more than 1/2 load).

If the engine cannot be operated under load every month, operate the engine under load (more than 1/2 load) for more than 2 hours.

During the engine maintenance operation, check the ease of startup, oil pressure, and exhaust color and vibration.

Periodic maintenance chart for general-purpose engine

If the engine is used for different purposes other than the above usage, do maintenance according to the "Periodic Maintenance Chart for General-Purpose Power Supply Engine".

General Definition of Regular-Use Engine, Emergency Engine and General-Purpose Engine

General definition of regular-use engine

An engine operated with a constant base load for the purpose of generating electric power, which is used independently or in combination with commercial power supply.

An engine operated under a fluctuating load throughout a day for supplying rated electric power in lieu of commercial power.

General definition of emergency engine

An engine used for emergency power generation such as main power supply and commercial power supply.

General definition of general-purpose engine

An engine used for a purpose other than power generation - for example, to drive a pump, as the main engine for a ship, and for an industrial vehicle - and operated under constant or cyclically varying load and speed.

Periodic Maintenance Chart for Engine in Regular Use

Table 5-1 Periodic Maintenance Chart for Engine in Regular Use (1 / 2)

Service Item		Page
Every 50 service hours or every month	Draining Water from the Fuel Tank	*
First 50 service hours for new or reconditioned engine	Retightening the Bolts and Nuts	*
	Changing Engine Oil, Oil Filters and Bypass Oil Filter (It is recommended to analyze the engine oil properties at the same time.) (The oil filters must be changed when the filter alarm lights.)	6-6
Every 250 service hours or every year	Changing Engine Oil, Oil Filters and Bypass Oil Filter (It is recommended to analyze the engine oil properties at the same time.) (The oil filters must be changed when the filter alarm lights.)	6-6
	Changing Governor Oil Filter	6-8
First 250 service hours for new or reconditioned engine	Inspection and Adjustment of Valve Clearances (Also inspect the valve mechanisms at the same time.)	*
Every 1000 service hours	Inspection of V-belt and Adjustment of Belt Tension	6-2
	Changing Fuel Filters	6-5
Every 2000 service hours	Changing V-belt	6-2
	Inspection of Fuel Control Linkage Ball Joints	6-4
	Inspection and Adjustment of Valve Clearances (Also check the valve mechanisms at the same time.)	*
	Inspection and Adjustment of Fuel Injection Timing	*
	Changing Fuel Injection Nozzle Tips (Check the spray condition and adjust the fuel injection pressure after replacement.)	*
	Checking Movement of the Rack (during operation) of the Fuel Injection Pump (including the governor)	*
Every 4000 service hours	Overhaul the Top End of the Engine Remove the cylinder head, and inspect and service the combustion chambers. • Inspect the connecting rod • Visually inspect top surfaces of each piston • Inspect the cylinder liner surfaces	*
	Inspection of Damper	6-3
	Inspection of Turbocharger	6-11
	Inspection of Starters	6-13
	Inspection of Alternator	6-13
	Checking the Protective Devices for Proper Operation	*
	Replacing the Unit Seals and Oil Seals in the Water Pump	*
	Checking the LLC Concentration in the Coolant	*

Items marked with * require special tools or large equipment. For servicing of these items, consult a Mitsubishi dealer.

Table 5-1 Periodic Maintenance Chart for Engine in Regular Use (2 / 2)

	Service Item	Page
Every 8000 service hours	Conduct a Major Overhaul Disassemble engine-clean, check and change major parts. <Parts to be changed> Inlet and exhaust valve seats, inlet and exhaust valves, valve rotators, valve cotters, rocker arm adjusting screws, valve push rods, bridge caps, camshaft bushings, camshaft expansion plugs, main bearings, cylinder liners, main bearing cap bolts and washers, piston rings, connecting rod bearings, damper, crankcase thrust plate and consumable items (gaskets, oil seals, O-rings, etc.) <In second overhaul, replace the following parts in addition to the parts listed above> Cylinder head bolts, valve guides, valve bridge guides, valve bridges, valve springs, tappets, camshaft thrust plates, rocker bushings, thrust plates, pistons, piston pins, connecting rod bolts, connecting rod bushings, rocker bushings, etc.	*
	Inspection and Testing of Fuel Injection Pump(Replace parts, if necessary.)	*
	Inspection and Testing of Governor (Replace parts, if necessary.)	*
	Correction or Replacement of Protective Devices. High coolant temperature, low oil pressure, overspeeding, starting failure, water supply failure, undervoltage, overvoltage, overcurrent, low coolant level in tank, low fuel level in tank, low air pressure in tank, etc.	*
	Checking the Auxiliary Devices for Proper Operation Water heater, oil heater, oil priming pump, fuel transfer pump, governor motor, etc.	*
Every 2 years	Changing Coolant	6-9
When required	Bleed the fuel system	3-2
	Inspection and Cleaning Radiator Fins	6-10
	Cleaning and Inspecting Air Cleaner Element	6-12
	Cleaning the Inside of the Engine Breathers	*
	Inspecting or Replacing the Stop Solenoid	*
	Inspecting or Replacing the Couplings	*
	Inspecting the Vibration-isolating Rubber	*

Items marked with * require special tools or large equipment. For servicing of these items, consult a Mitsubishi dealer.

Periodic Maintenance Chart for Emergency Engine

Table 5-2 Periodic Maintenance Chart for Emergency Engine (1 / 3)

Service item		Page	
Every week	Conducting External Inspection.(Check for leakage of fuel, oil and coolant.)	3-8	
	Checking the Fuel Level in the Fuel Tank	3-1	
	Checking Engine Oil Level	3-9	
	Checking Coolant Level	3-10	
	Inspection of Air Tank Air Pressure	3-11	
	Check air cooler for water leaks.	*	
	Conducting an Engine Maintenance Operation(Operate the engine under no load for 5 to 10 minutes.) Check for ease of starting, color of exhaust smoke, abnormal vibration, abnormal noise, abnormal smell and gauge indication " (oil pressure gauge, coolant temperature gauge, oil temperature gauge, exhaust temperature gauge, tachometer, etc.)"	*	
Every month	Inspection of Fuel Control Linkage Ball Joints	6-4	
	Clean fuel filter (wire element type) - turn handle one or two times.	-	
	Inspection of Engine Oil for Mixing of Fuel and Water	6-7	
	Electrolyte level	6-14	
	Check oil level in air compressor - add oil.	-	
	Draining Water from Air Tank	6-15	
	Conducting Engine Maintenance Operation (Operate the engine with more than 1/2 load for 15 to 30 minutes.) Check for ease of starting, color of exhaust smoke, abnormal vibration, abnormal noise, abnormal smell and gauge indication (oil pressure gauge, coolant temperature gauge, oil temperature gauge, exhaust temperature gauge, tachometer, etc.) Check fuel injection pump and hydraulic and electronic governor rack movement."	*	
Every 6 months	Checking LLC Concentration in the Coolant	*	
	Cleaning the Inside of the Coolant Tank	*	
Every year	Basic block	Inspection of V-belt and Adjustment of Belt Tension	6-2
		Inspection of External Bolts and Nuts for Tightness, and Retighten If Necessary	*
		Inspection of Damper	6-3
		Inspection and Adjustment of Valve Clearance (Inspect the parts related to valve mechanism at the same time.)	*
		Inspection of Vibration-isolating Rubber	*
		Inspection of Foundation Bolts	*
		Inspection or Replacement of Couplings	*
	Fuel system	Drain water and sediment from fuel tank.	*
		Drain water from fuel filter (wire element type).	*
		Inspection and Adjustment of Fuel Injection Nozzle Spray Condition and Spray Pressure	*
		Inspection and Adjustment of Fuel Injection Timing	*

Items marked with * require special tools or large equipment. For servicing of these items, consult a Mitsubishi dealer.

Table 5-2 Periodic Maintenance Chart for Emergency Engine (2 / 3)

Service Item		Page	
Every year	Lubrication system	Analyzing Engine Oil Properties	*
		Inspection and Adjustment of Engine Oil Pressure (Maintenance operation)	*
	Cooling system	Inspection of Water Pump	*
		Inspection, Disassembly and Cleaning of Electromagnetic Valve and Pressure Reducing Valve of the Cooling System	*
		Inspection, Disassembly and Cleaning of Strainer (including with/ ball tap) of Cooling Water	*
		Analyzing Coolant Properties (when only soft water is used) (Change coolant according to the analysis results.)	*
	Air inlet system	Cleaning and Inspecting Air Cleaner Element	6-12
		Cleaning Pre-Cleaner	6-11
	Electrical system	Inspection of Starters	6-13
		Inspection of Alternator	6-13
		Checking specific gravity of electrolyte	6-14
		Inspection of Air Heater	*
	Air - start system	Draining Water and Cleaning Air Starter Strainer	6-15
		Inspection Safety Valve of Air Tank	6-15
		Check starter valve.	*
		Check solenoid valve - clean.	*
		Check distributor valve.	*
		Check air compressor drive belt.	*
	Checking Protection Devices for Proper Operation High coolant temperature, low oil pressure, overspeeding, starting failure, water supply failure, undervoltage, overvoltage, overcurrent, low coolant level in tank, low fuel level in tank, low air pressure in tank, etc.		*
	Checking Auxiliary Devices for Proper Operation Engine control, fuel transfer pump, governor motor, room ventilating fan, solenoid, storage pump, water tank ball tap, water heater, oil heater, oil priming pump, etc.		*
Every 2 years	Inspection of Fuel Control Linkage Ball Joints		6-4
	Changing Fuel Filters		6-5
	Changing Engine Oil, Oil Filters and Bypass Oil Filter (It is recommended to analyze engine oil properties at the same time.) (Change oil filters whenever filter alarm turns on.)		6-6
	Changing Coolant		6-9
	Inspection of Turbocharger		6-11
	Draining Water From Exhaust Muffler		6-11
	Inspection of Thermostat		*
	Clean fuel filter (wire element type).		*
	Overhaul air compressor.		*

Items marked with * require special tools or large equipment. For servicing of these items, consult a Mitsubishi dealer.

Table 5-2 Periodic Maintenance Chart for Emergency Engine (3 / 3)

	Service Item	Page
Every 4 years	Cleaning Fuel Tank	6-4
	Inspection and Cleaning Radiator Fins	6-10
	Cleaning and Inspecting Air Cleaner Element	6-12
	Checking Oil Cooler for Soiling, Clogging and Leakage	*
	Checking Oil Pump for Discoloration and Other External Defects	*
	Inspection and Testing of Fuel Injection Pump (Replace parts if necessary.)	*
	Inspection and Testing of Governor (Replace parts if necessary.)	*
	Changing the Rubber Hoses	*
	Repair or Replacement of Instruments Oil pressure gauge, coolant temperature gauge, oil temperature gauge and tachometer.	*
Every 8 years	Inspection and Replacement of Main Engine Parts (major overhaul) Inlet and exhaust valves and valve seats (lapping), valve guides, pistons, piston rings, connecting rod metals, connecting rod bushings, cylinderliners and crankshaft (If the parts for No. 1 and No. 2 cylinders are found defective, change the parts for all cylinders.)	*
	Replacement of Damper	*
	Repair or Replacement of Oil Pump	*
	Replacement of Fuel Injection Nozzle Tips (Adjust the spray condition and spray pressure after replacement.)	*
	Replacement of Rubber Parts and O-rings	*
	Replacement of Unit Seal, Oil Seal of the Water Pump	*
	Disassembly and Inspection of Turbocharger	*
	Disassembly and Cleaning of Air Cooler	*
	Repair or Replacement of Vibration-isolating Rubber	*
	Repair or Replacement of Couplings	*
	Adjustment or Replacement of Governor Motor	*
	Adjustment or Replacement of Air Ventilation Fan of the Room	*
	Inspection or Replacement of Stop Solenoid	*
	Adjustment or Replacement of Ball Tap of Water Tank	*
Replacement of Other Consumables	*	

Items marked with * require special tools or large equipment. For servicing of these items, consult a Mitsubishi dealer.

Periodic Maintenance Chart for General-Purpose Power Supply Engine

Table 5-3 Periodic Maintenance Chart for General-Purpose Power Supply Engine (1 / 2)

Service Item		Page
Every 50 service hours or every month	Draining Water from Fuel Tank	3-9
	Draining Water Air Starter Strainer	6-15
	Draining Water from Air Tank	6-15
After first 50 service hours for new engine	Retightening External Bolts and Nuts for Looseness	*
	Changing Engine Oil, Oil Filters and Bypass Oil Filter (It is recommended to analyze engine oil properties at the same time.) (Change the oil filters whenever the filter alarm turns on.)	6-6
Every 250 service hours or every year	Inspection of V-belt and Adjustment of Belt Tension	6-2
	Changing Engine Oil, Oil Filters and Bypass Oil Filter (It is recommended to analyze engine oil properties at the same time.) (Change the oil filters whenever the filter alarm turns on.)	6-6
	Changing Governor Oil Filter	6-8
	Inspection and Cleaning Radiator Fins	6-10
	Draining Water From Exhaust Muffler	6-11
	Inspection Safety Valve of Air Tank	6-15
First 250 service hours for new engine	Inspection and Adjustment of Valve Clearances (Check the valve mechanism and parts at the same time.)	*
Every 1000 service hours or every 2 years	Changing Fuel Filters	6-5
	Cleaning Air Starter Strainer	6-15
	Change zinc rods.	*
Every 2000 service hours or every 3 years	Retightening External Bolts and Nuts	*
	Inspection and Adjustment of Valve Clearances (Check the valve mechanism and parts at the same time.)	*
	Inspection and Adjustment of Fuel Injection Timing	*
	Replacement of Fuel Injection Nozzle Tips (Inspect and adjust spray condition and fuel injection pressure after replacement).	*
	Checking Operation of Protection Devices	*
Every 4000 service hours or every 5 years	Overhaul of Top End of Engine Remove the cylinder head, and inspect and service the combustion chambers. <ul style="list-style-type: none"> • Disassemble, inspect and service the cylinder head. • Inspect the intake and exhaust valves, and lap the valves against seats • Visually inspect the top surface of each piston. • Inspect the cylinder liner surfaces. 	*
	Inspection of Damper	6-3
	Inspection of Fuel Control Linkage Ball Joints	6-4
	Cleaning Air Cooler	*
	Wash heat exchanger	*

Items marked with * require special tools or large equipment. For servicing of these items, consult a Mitsubishi dealer.

Table 5-3 Periodic Maintenance Chart for General-Purpose Power Supply Engine (2 / 2)

	Service Item	Page
Every 8000 service hours	Conducting Major Overhaul Disassemble engine-clean, check and change major parts.	*
	Inspection and Testing of Fuel Injection Pump(Replace parts, if necessary.)	*
	Inspection and Testing of Governor (Replace parts, if necessary.)	*
	Correction or Replacement of Protective Devices High coolant temperature, low oil pressure, overspeeding, starting failure, water supply failure, undervoltage, overvoltage, overcurrent, low coolant level in tank, low fuel level in tank, low air pressure in tank, etc.	*
	Checking the Auxiliary Devices for Proper Operation Water heater, oil heater, oil priming pump, fuel transfer pump, governor motor, etc.	*
Every 2 years	Changing Coolant	6-9
When required	Bleed the fuel system	3-2
	Cleaning Pre-Cleaner	6-11
	Cleaning and Inspecting Air Cleaner Element	6-12

Items marked with * require special tools or large equipment. For servicing of these items, consult a Mitsubishi dealer.

Chapter 6

PERIODIC INSPECTION AND MAINTENANCE PROCEDURES

External View

External Inspection

▲ CAUTION

A fire can be caused by combustible materials placed near hot engine parts (exhaust manifolds and other exhaust gas passages) or battery, fuel leaks, and oil leaks. Check the engine exterior carefully. If an abnormality is found, be sure to repair or contact a Mitsubishi dealer.

Before starting the engine, clean the top surface of the battery with wet cloth.

Inspect the engine exterior as described below.

- 1 Make sure there is no combustible material near the engine or battery. Also, check to make sure the engine and battery are clean.
If combustible materials or waste are found near the engine or battery, remove them.
- 2 Check the entire engine for leakage of fuel, engine oil or coolant. If leaks are found, repair leakage or contact a Mitsubishi dealer.
- 3 Check the electrical wiring including the starters.

Inspection of V-belt and Adjustment of Belt Tension

CAUTION

If damage or surface separation is found on the V-belt during inspection, replace the V-belt.

Keep oil and grease away from the belt, since they may cause the belt to slip and shorten the service life.

Excessive V-belt tension can cause rapid wear of the alternator bearing and shorten the service life of the belt.

Adjust the belt tension accurately by following the procedures below.

Inspecting the V-belt

- 1 Inspect the external appearance of the V-belt. If damage or surface separation is found on the V-belt, replace the V-belt with a new belt.
- 2 When force (approx. 98 to 147 N [10 to 15 kgf]) applied to the center section of the V-belt causes the belt to deflect 10 to 15 mm [0.39 to 0.59 in.], the belt tension is appropriate.
- 3 To adjust the belt tension, turn the adjusting rod.

Adjusting the V-belt tension (Alternator side)

- 1 Remove the alternator front cover and belt cover.
- 2 Loosen all retaining bolts on the alternator and adjusting rod.
- 3 Loosen the upper and lower lock nuts on the adjusting rod.

Note: Note that the lower nut on the adjusting rod has left-hand threads.

- 4 Turn the adjusting rod to adjust the V-belt tension.
- 5 After the tension adjustment, tighten the upper and lower lock nuts.
- 6 Tighten all the retaining bolts on the alternator and adjusting rod.
- 7 Reinstall the alternator front cover and belt cover.

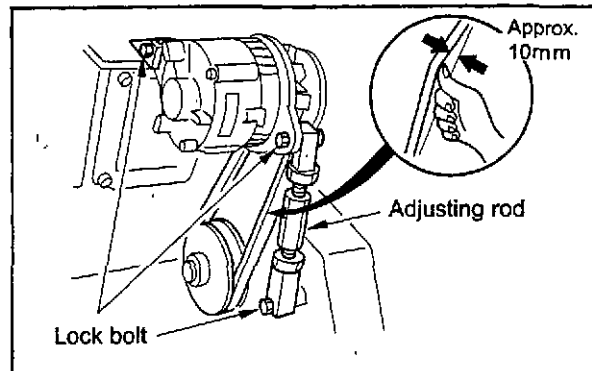

fig.6-1 Inspecting the V-belt and adjusting the belt tension

Adjusting the V-belt tension (Water pump side)

- 1 Remove the belt cover.
- 2 Loosen all the retaining bolts on the tension pulley sliding plate.
- 3 Loosen the lock nuts on the adjusting rod and tighten the bolts to have belt tension.
- 4 Retighten all the retaining bolts on the tension pulley sliding plate.
- 5 Reinstall the belt cover.

Inspection of Damper

External inspection of damper

CAUTION

When installing a damper protective cover to the engine, do not use a cover that encloses the damper. Installation of a closed cover can cause damper damage due to heat.

Check the vibration damper for oil leakage, scratches, deformation, discoloration and peeling of paint.

Check carefully for swelling on the cover (use a scale), oil leaks from the shim, discoloration and peeling of paint due to heat.

Note: If the vibration damper is defective, consult a Mitsubishi dealer.

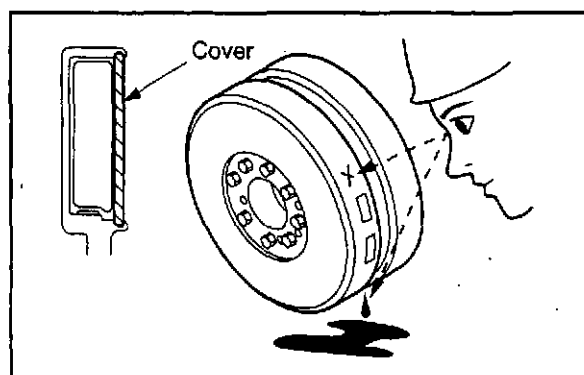

fig.6-2 Inspecting the damper

Damper temperature management

For proper operation, heat of the vibration damper must be dissipated from its surface to prevent excessive damper heating. Mitsubishi inspects each engine before shipment to ensure proper operating temperature of the vibration damper. However, the vibration damper temperature varies depending on ambient conditions. Therefore, observe the following suggestions and provide sufficient ventilation for the vibration damper and equipment.

In the case of viscous damper of regular use engine, make sure the temperature of the outside damper surface does not exceed 90 °C [194 °F] after the engine is operated at the rated output for 1 hour, and emergency engine for 100 °C [212 °F]. In the case of viscous rubber damper of regular use engine, make sure the temperature does not exceed 80 °C [176 °F], and emergency engine for 90 °C [194 °F]. It is recommended to use the thermo label for temperature management of the vibration damper in regular use engine.

Table 6-1 Temperature Management with Thermo Label

Parts name	Parts No.	Temperature measuring range
Thermo label 75-95	32522-04100	75 to 95 °C [167 to 203 °F]
Thermo label 100-120	32522-04200	100 to 120 °C [212 to 248 °F]
Thermo label 50-70	32522-04300	50 to 70 °C [122 to 158 °F]

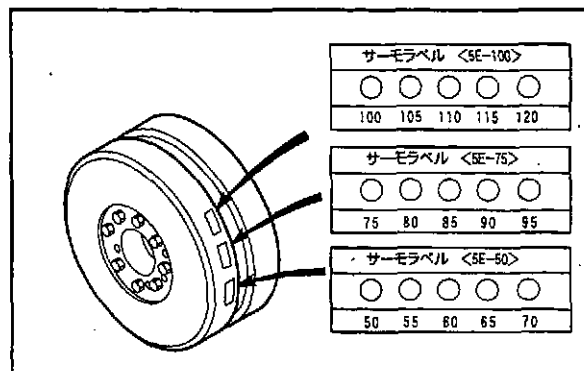

fig.6-3 Managing the damper temperature

When installing a safety cover over the vibration damper, check ventilation carefully and make sure the damper temperature remains below the above temperature with the cover in place.

Fuel System

Inspection of Fuel Control Linkage Ball Joints

Check the ball joints in the fuel control linkage for looseness.

If the amount of looseness is more than 0.1 mm [0.004 in.], replace the ball joints.

CAUTION

If the ball joint attached with a seal is loose, consult a Mitsubishi dealer.

If the seal on the ball joint is broken, the warranty may be invalidated.

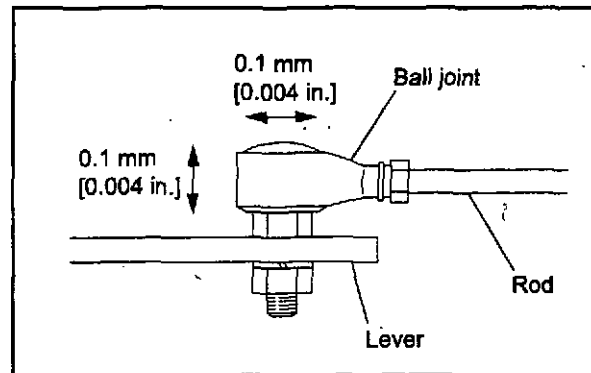

fig.6-4 Inspection of the fuel control linkage for looseness

If the ball joints are integrated in the control linkage, replace the control linkage when the ball joints are loose.

When installing ball joints, be sure to tighten the nuts firmly.

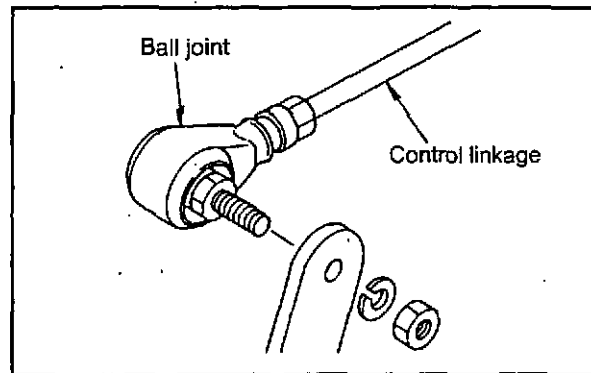

fig.6-5 Removing the fuel control linkage

Cleaning Fuel Tank

WARNING

When handling fuel, make sure there are no flames near the engine.

Wipe any spilled fuel completely. Spilled fuel can ignite and cause fire.

CAUTION

Do not remove the strainer when filling the fuel tank.

Use fuel specified in "Fuel" (4-2).

- 1 Close the valve on the fuel supply line from the fuel tank.
- 2 Arrange a fuel receiving can.
- 3 Drain all fuel from the fuel tank through the drain cock located on the bottom of the fuel tank into the fuel receiving can.
- 4 Clean the inside of the fuel tank.

Note: Regarding cleaning of the fuel tank, refer to the instructions provided with the fuel tank.

- 5 Bleed the fuel system.

Note: Regarding bleeding of the fuel system, refer to "Bleed the fuel system" (3-2).

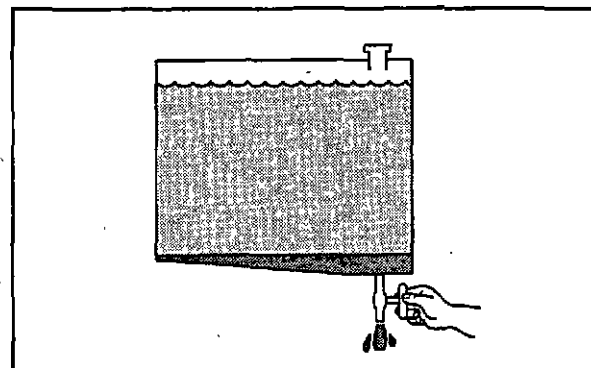

fig.6-6 Cleaning fuel tank

Changing Fuel Filters

WARNING

When handling fuel, make sure there are no flames near the engine.
Wipe any spilled fuel completely. Spilled fuel can ignite and cause fire.

- 1 Clean the area around the fuel filters.
- 2 Place a fuel receiving tray under the fuel filters.
- 3 Using the provided filter wrench, remove each fuel filter.
- 4 Wipe fuel from the fuel filter cartridge mounting surface of the filter bracket with a cloth.
- 5 Check the new fuel filter for proper seating of the gaskets.
- 6 Apply clean fuel to the gaskets on the new fuel filter.
- 7 Install the fuel filter. When the gasket contacts the mounting surface on the filter bracket, further rotate 3/4 to a full turn.

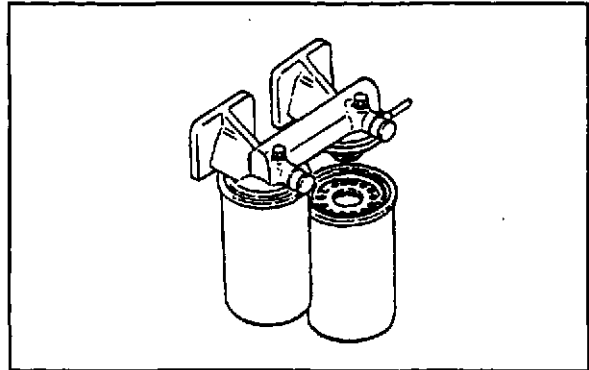

fig.6-7 Changing fuel filters

CAUTION

Do not use the filter wrench for the installation of fuel filters.

Do not dent or scratch the fuel filter surfaces.

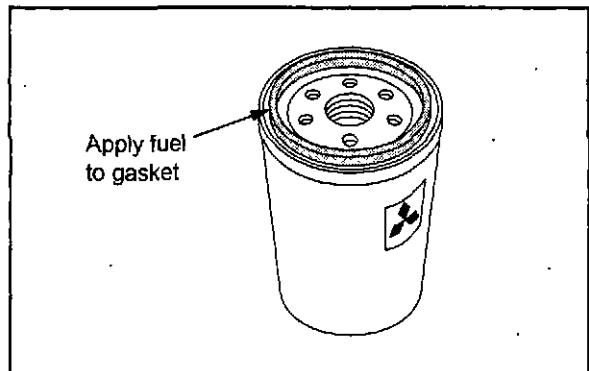

fig.6-8 Fuel filter

- 8 After installing the new fuel filter, bleed the fuel system.

Note: Regarding bleeding of the fuel system, refer to "Bleeding Fuel System" (6-14).

- 9 Start the engine and let it idle for several minutes.
- 10 Check the fuel filter mounting sections for fuel leakage. If fuel leakage is found, loosen the fuel filter and check the gaskets for damage. If there is no gasket damage, retighten the fuel filter.

Lubricating System

Changing Engine Oil, Oil Filters and Bypass Oil Filter

WARNING

To drain oil or change oil filters, wear gloves. Hot engine oil and parts may cause burns.

CAUTION

When changing engine oil, change the oil filters and bypass oil filter at the same time.

It is recommended to analyze engine oil properties at the same time.

Also change the oil filters whenever the filter alarm turns on.

Draining engine oil

To ensure thorough drainage, drain engine oil while it is still warm after engine operation.

Note: Do not suck out the engine oil when draining.

Changing oil filters and bypass oil filter

- 1 Clean the area around the oil filters.
- 2 Place an oil-receiving tray under the oil filters.
- 3 Using the provided filter wrench, remove each oil filter.

Note: Check the filter elements in the removed oil filter for metal particles. If metal particles are found, consult a Mitsubishi dealer. Also change the oil filters whenever the filter alarm turns on.

- 4 Wipe oil from the oil filter mounting surface on the filter alarm bracket with a cloth.
- 5 Check the new oil filter for proper seating of the gaskets.
- 6 Apply clean engine oil to the gaskets on the new oil filter.
- 7 Install the oil filter. When the gasket contacts the mounting surface on the filter bracket; further rotate 3/4 to a full turn.

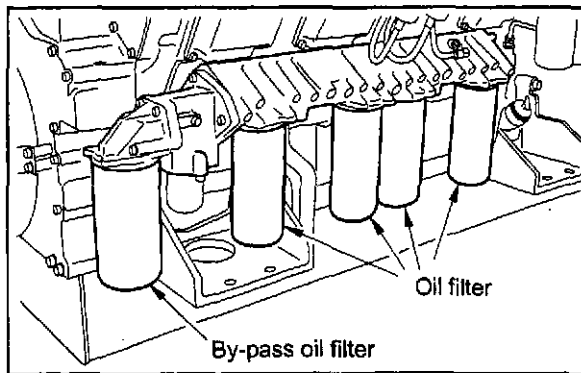

fig.6-9 Oil filters and bypass oil filter

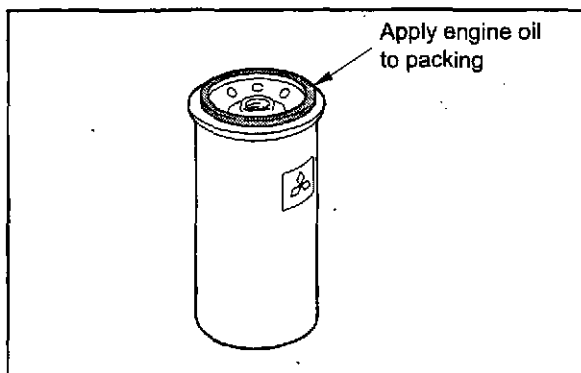

fig.6-10 Oil filter

CAUTION

Do not use the filter wrench for the installation of oil filters.

Do not dent or scratch the oil filter cartridge surfaces.

Pouring engine oil

- 1 Reinstall the drain plug.
- 2 Remove the cap from the oil filler.
- 3 Pour designated engine oil to the specified level.

Specified engine oil: Class CD or CF

(API Service Classification)

Engine oil capacity

Oil pan: 200 L [52.84 U.S. gal.]

(entire engine: 250 L [66.05 U.S. gal.])

Note: Regarding engine oil, refer to "Engine Oil" (4-4).

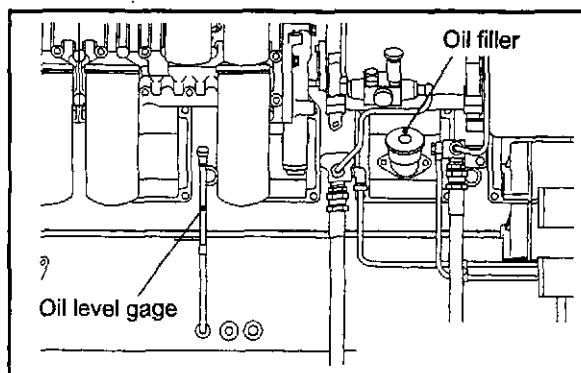

fig.6-11 Oil filler and oil level gage

- 4 Check the oil level in the oil pan.
Pull out the oil level gage and wipe it with a cloth.
- 5 Insert the oil level gage fully into the oil level gage guide, then pull the gage out again.
The oil level should be between the **MAXIMUM** and **MINIMUM** marks on the oil level gage.
If the oil level is low, add engine oil of the specified type.
- 6 Check the oil pan and other parts for oil leakage. Repair any oil leakage found.
- 7 Crank the engine for about 10 seconds or less using the starters, and wait for about 1 minute.
- 8 Repeat the above cranking operation several times to circulate oil in the engine.

CAUTION

To crank the engine, shut off the fuel supply to the engine (keep the control rack of the fuel injection pump in the OFF position) and operate the starters.

- 9 Check the oil level with the oil level gage again, and add oil if necessary.

Inspection of Engine Oil for Mixing of Fuel and Water

Sample 1 to 2 L [0.26 to 0.53 U. S. gal] of engine oil, and check for abnormal odor and discoloration to determine the mixing of fuel and water.

If fuel is mixed with the engine oil, the oil will smell like fuel.

If water is mixed with the engine oil, the oil will be milky white.

If fuel and/or water is mixed with the engine oil, contact a Mitsubishi dealer.

Note: Regarding replenishment of engine oil, refer to "Lubricating System" (3-4).

If the engine continues to operate with engine oil mixed with fuel or water, the engine oil viscosity decreases and this can cause serious accidents such as seizing of bearings. If fuel or water is detected in the engine oil, find the cause of the problem, and repair. If the problem cannot be corrected easily, contact a Mitsubishi dealer.

Changing Governor Oil Filter

⚠ WARNING

To drain oil or change oil filters, wear gloves. Hot engine oil and parts may cause burns.

- 1 Place the oil receiving tray under the governor filter.
- 2 Loosen the air vent plug and remove the drain plug. Drain oil in the filter.
- 3 Remove the oil pipe from the center bolt.
- 4 Remove the center bolt and remove the case from the bracket. Remove the used element from the case.
- 5 Put a new element in the case using the center bolt.
- 6 Install the case to the filter bracket. Tighten the center bolt.
- 7 Install the oil pipe to the center bolt.
- 8 Install the drain plug.
- 9 Remove the air vent plug and fill up the filter with engine oil. Install the air vent plug.
- 10 After filling oil up, reinstall the air vent plug.

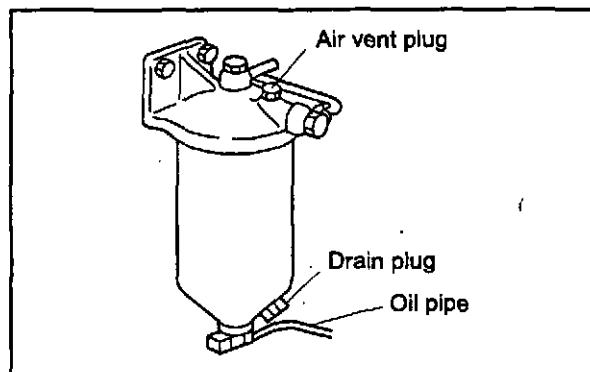

fig.6-12 Governor oil filter

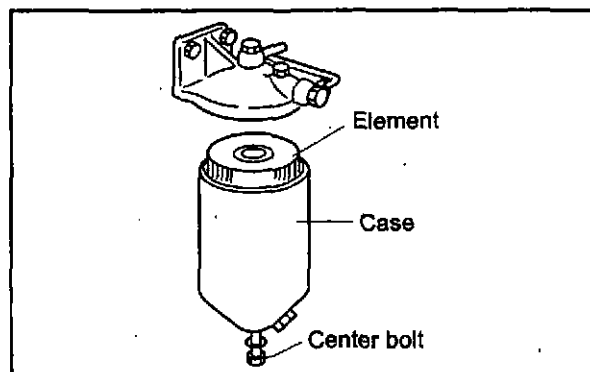

fig.6-13 Changing governor oil filter

Cooling System

Changing Coolant

WARNING

Remove the radiator cap only after the engine cools to room temperature. Place a cloth over the cap, and turn the cap about a half turn or stand the lever to upright position to release internal pressure. Opening the radiator cap while the engine is hot causes steam and hot coolant to blow out, resulting in skin burns. Coolant (containing LLC) drained from an engine is toxic, and must not be disposed of into regular sewage. For disposal of used coolant, consult a Mitsubishi dealer.

CAUTION

The service life of LLC is 2 years. Be sure to change coolant at least once every 2 years.

Draining coolant

- 1 When draining coolant immediately after engine operation, let the engine idle at low speed for 5 to 6 minutes and lower the coolant temperature to 70 to 80°C [158 to 176°F].
- 2 Open the radiator cap.
- 3 Place coolant receiving cans under the drain cocks on the engine and water pump, and open the drain cocks to drain coolant.

Cleaning the cooling system

- 1 Close the drain cocks or plug.
- 2 Pour a cleaning solution (non-corrosive solution to rubber and metals) in the cooling system, and operate the engine at 800 to 900 min⁻¹ for about 15 minutes, then drain the cleaning solution.
- 3 Close the drain cocks or plugs.
- 4 Pour fresh water, and operate the engine at 800 to 900 min⁻¹ for about 10 minutes.
Continue flushing the cooling system in the above manner until the draining water is clear.

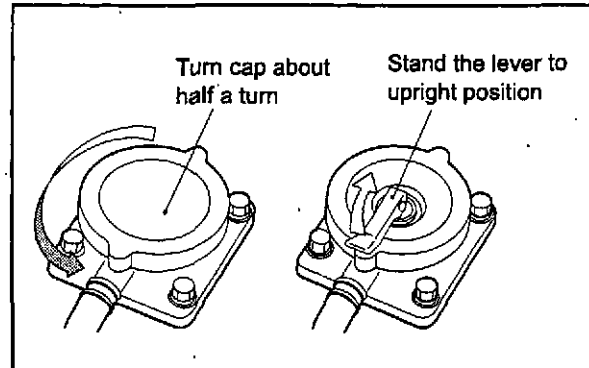

fig.6-14 Radiator cap

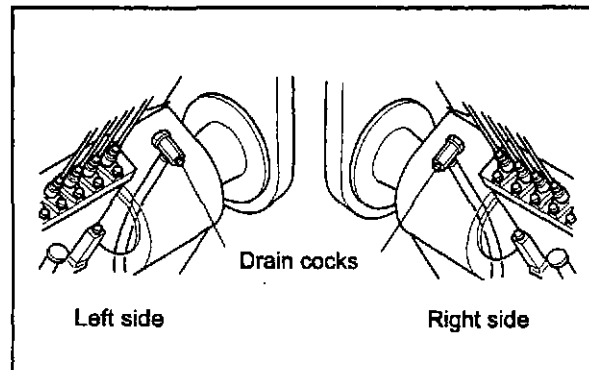

fig.6-15 Draining coolant (Engine main parts)

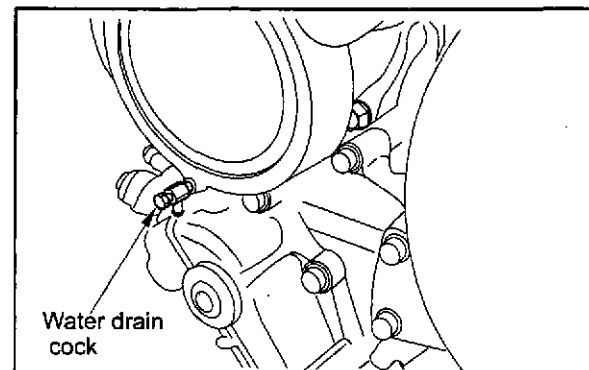

fig.6-16 Draining coolant (Water pump)

Pouring coolant

- 1 Make sure the drain cocks on the engine and water pumps are closed tightly.
- 2 Remove the expansion tank cap, and pour undiluted LLC.

Note: (a) Determine the amounts of LLC and water to be poured by using the LLC concentration chart.
 (b) Regarding coolant, refer to "Coolant" (4-5).

Coolant capacity (engine only)
 Approx. 170 L [44.91 U.S.gal.]

- 3 Pour water (soft water with minimal impurities, such as tap water) slowly to the full level.
- 4 Check the expansion tank and other parts for coolant leakage.
 If coolant leakage is found, repair.
- 5 When coolant reaches the full level, close the expansion tank cap securely.
- 6 Crank the engine for about 10 seconds or less using the starters.
 Wait for about 1 minute, then repeat the above cranking operation several times to remove air from the water pump.

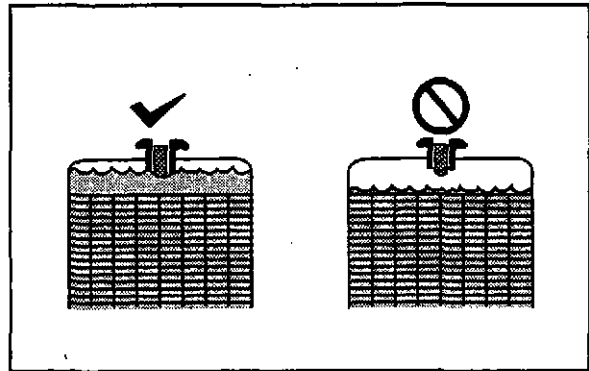

fig.6-17 Radiator

CAUTION

To crank the engine, shut off the fuel supply to the engine (keep the control rack of the fuel injection pump in the OFF position) and operate the starters.

- 7 Check the coolant level in the expansion tank.
- Note: Coolant to be added should have the same LLC concentration as the coolant in the engine.

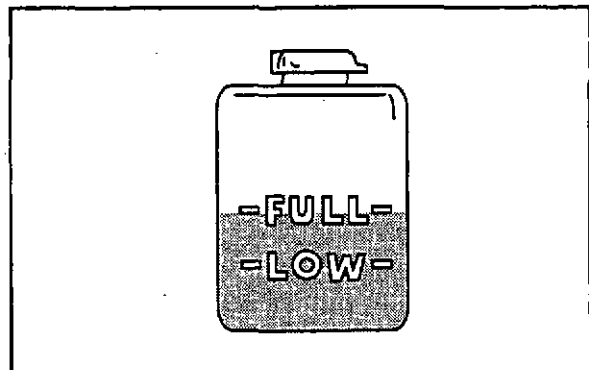

fig.6-18 Reserve tank

Inspection and Cleaning Radiator Fins

Check radiator fins for holes and cracks.

To clean radiator fins, blow compressed air in the direction opposite to normal air flow.

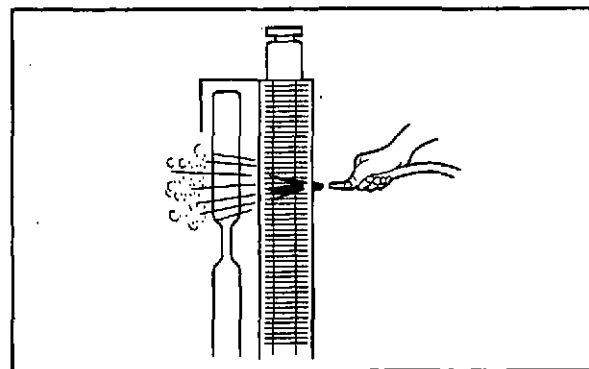

fig.6-19 Cleaning radiator fins

Pouring coolant

- 1 Make sure the drain cocks on the engine and water pumps are closed tightly.
- 2 Remove the expansion tank cap, and pour undiluted LLC.

Note: Determine the amounts of LLC and water to be poured by using the LLC concentration chart. Regarding coolant, refer to "Coolant and LLC" (4-9).

Regarding engine oil capacity, refer to "Main Specifications" (10-1).

- 3 Pour water (soft water with minimal impurities, such as tap water) slowly to the full level.
- 4 Check the expansion tank and other parts for coolant leakage.
If coolant leakage is found, repair.
- 5 When coolant reaches the full level, close the expansion tank cap securely.
- 6 Crank the engine for about 10 seconds or less using the starters.
Wait for about 1 minute, then repeat the above cranking operation several times to remove air from the water pump.

CAUTION

To crank the engine, shut off the fuel supply to the engine (keep the control rack of the fuel injection pump in the OFF position) and operate the starters.

- 7 Check the coolant level in the expansion tank.

CAUTION

Coolant to be added should have the same LLC concentration as the coolant in the engine.

Inspection and Cleaning Radiator Fins

Check radiator fins for holes and cracks.

To clean radiator fins, blow compressed air in the direction opposite to normal air flow.

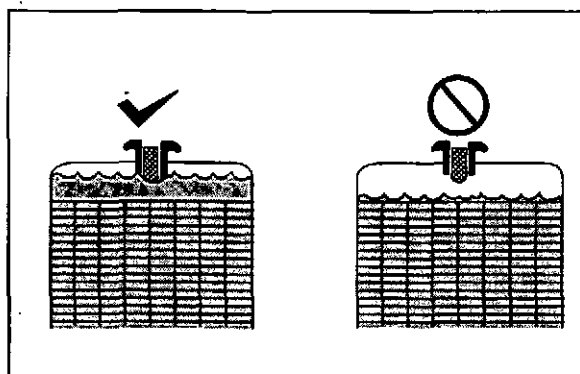

fig.6-18 Radiator

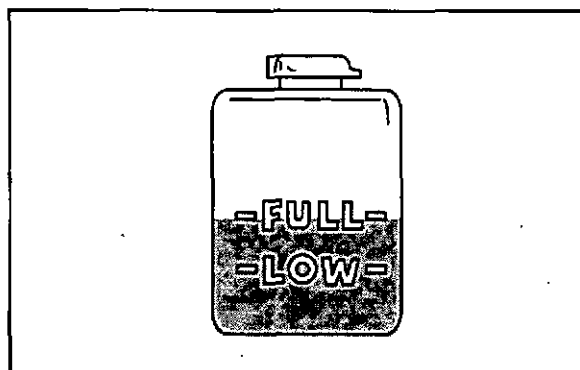

fig.6-19 Reserve tank

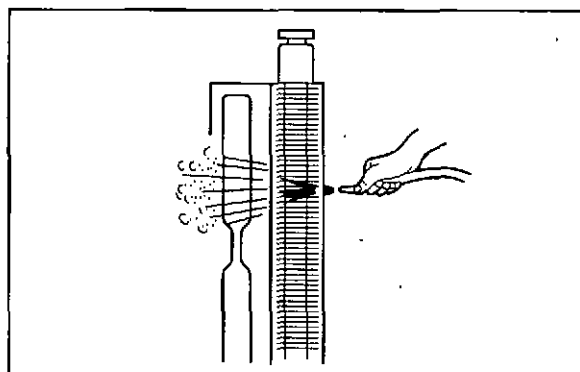

fig.6-20 Cleaning radiator fins

Cleaning and Inspecting Air Cleaner Element

CAUTION

Do not service the air cleaner while the engine is running. Maintenance of the air cleaner while the engine is in operation can cause dust to enter the engine and result in rapid wear of parts, leading to a shorter service life.

Never knock or hit the element.

- 1 Remove the air cleaner cap.
- 2 Remove the wing nut securing the element in place. Pull out the element from the body, and install a new element.
- 3 Blow compressed air (0.69 MPa (7 kgf/cm²) [100 psi] or lower) onto the inside surface of the element to remove dust and other contaminants.
- 4 To remove dust stuck on the element, blow dry compressed air onto the outside surface from a distance. Blow compressed air on the inside surface toward outside along the net pattern. Then, blow compressed air on the outside and inside surface again.
- 5 After cleaning, place a light bulb in the element to check for damage, pinholes and worn sections.

CAUTION

If damage is found in the element or if the air cleaner indicator shows red sign soon after the cleaned element is installed, install a new filter element in the air cleaner.

If the indicator shows a red sign, after the clean element is installed, reset the indicator by pressing the reset button.

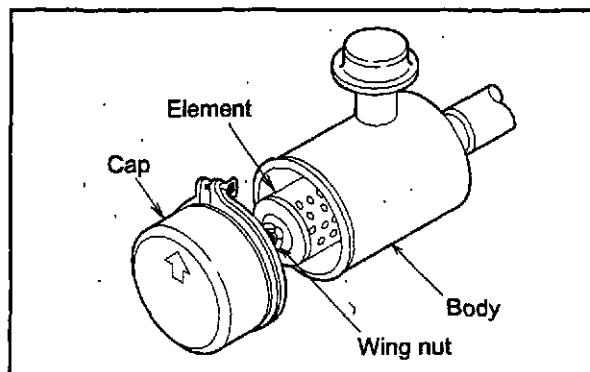

fig.6-23 Removing air cleaner element

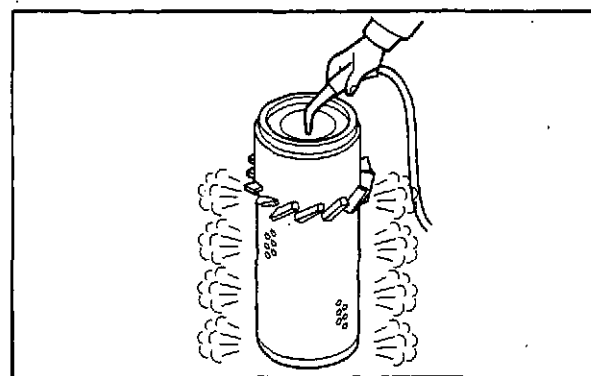

fig.6-24 Cleaning air cleaner element

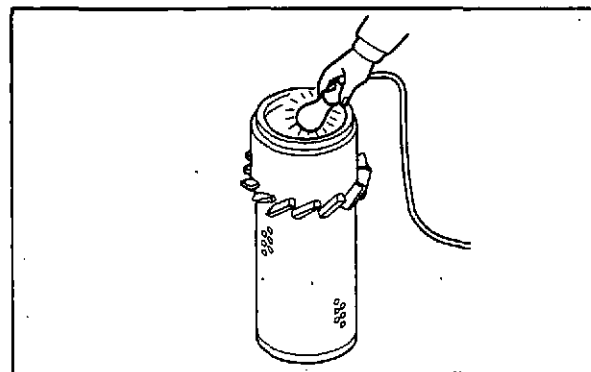

fig.6-25 Inspecting air cleaner element

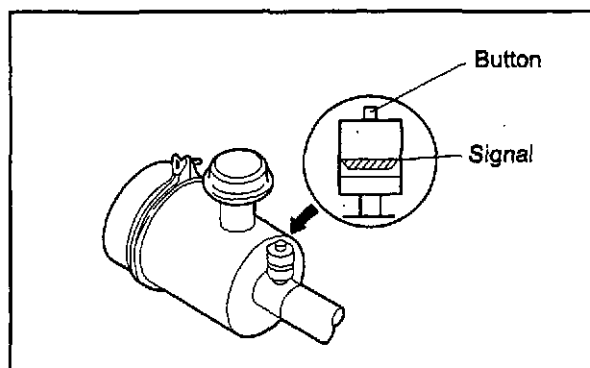

fig.6-26 Air cleaner indicator

Electrical System Inspection of Starters

CAUTION

Do not set the starter switch to the START position. Otherwise, the engine may start operating unexpectedly.

- 1 Check the exterior of the starters for damage.
- 2 If the starters are dusty, blow dirt using compressed air.

Note: If the starters are defective, consult a Mitsubishi dealer.

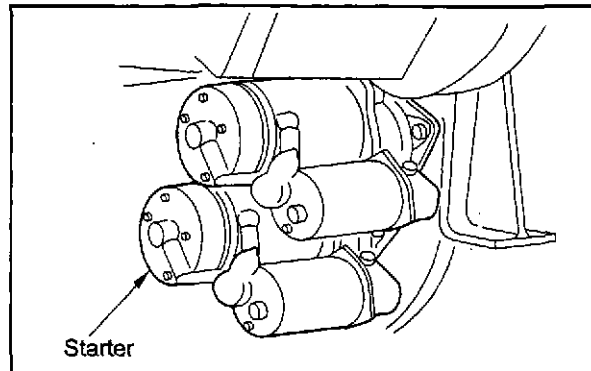

fig.6-27 Inspection of Starters

Inspection of Alternator

- 1 Check the exterior of the alternator for damage.
- 2 If the alternator is dusty, blow dirt using compressed air.
- 3 Remove the V-belt, and turn the pulley to make sure it rotates smoothly.

Note: If the alternator is defective, consult a Mitsubishi dealer.

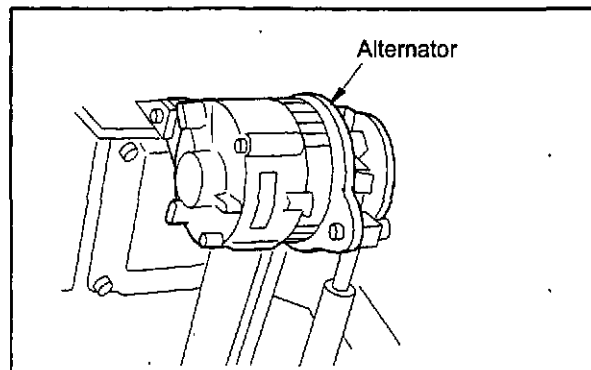

fig.6-28 Inspection of Alternator

Checking Battery

⚠ WARNING

If electrolyte is spilled on the eyes, skin or clothes, wash immediately with plenty of water. If electrolyte enters the eyes, flush immediately with lots of fresh water and see a physician.

Do not use flames near the battery. When handling the battery, be careful of sparks generated by accidental shorting.

Regarding other cautions in handling the battery, refer to "Caution Service Battery" (1-5).

Electrolyte level

Electrolyte evaporates during use and the fluid level gradually decreases. The fluid surface should be between the LOWER LEVEL and UPPER LEVEL lines. If there are no level lines on the battery, make sure that the fluid surface is about 10 to 15 mm [0.394 to 0.591 in.] above the top edges of the plate. If the fluid level is lower, remove the caps and add distilled water to the proper level.

Note: When pouring fresh electrolyte, pour the fluid carefully.

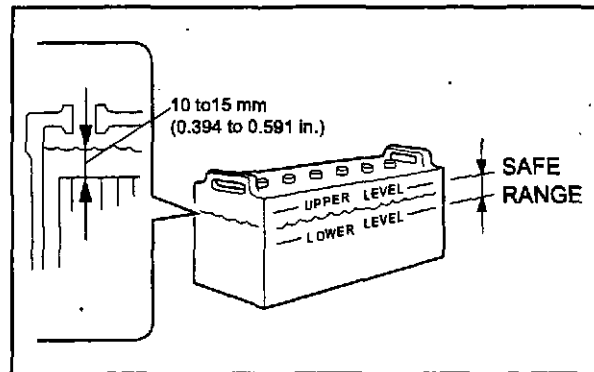

fig.6-29 Inspecting electrolyte level

Checking specific gravity of electrolyte

Check the specific gravity of the electrolyte. If the specific gravity measured at 20 °C [68 °F] is lower than 1.22, then charge the battery.

Table 6-2 Specific gravity of electrolyte

Specific gravity at 20°C [68°F]	Condition	Remedy
From 1.26 to 1.28	Fully charged	-
From 1.22 to 1.26	Charged	Charge
Less than 1.22	Discharged	Charge

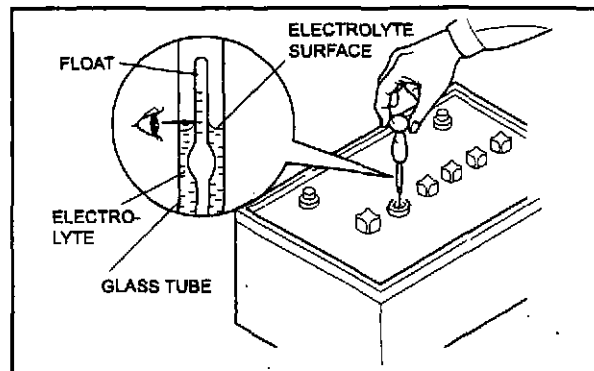

fig.6-30 Inspecting specific gravity of electrolyte

Air Starter System

Draining Water and Cleaning Air Starter Strainer

- 1 Close the starter valve handle of the air starter tank.
- 2 Remove the drain plug of air starter strainer and drain water from the air strainer.
- 3 Remove the cap and remove the filter from the cap.
- 4 Clean the filter with diesel fuel, then blow compressed air to dry.
- 5 Reinstall the air strainer as it is.
- 6 Open the air starter handle slowly.

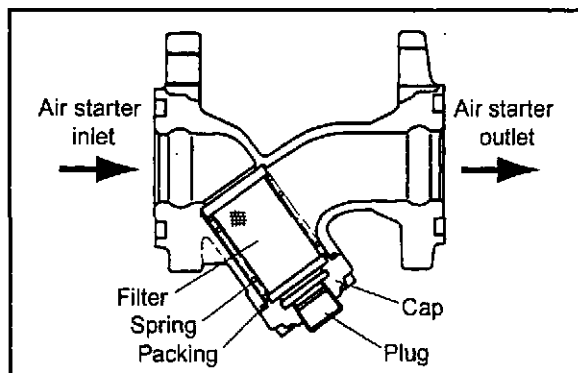

fig.6-31 Air starter strainer

Draining Water from Air Tank

WARNING

Slowly open the starting air handle of the air tank. If the handle is opened quickly, the engine can start abruptly and cause an unexpected accident.

- 1 Close the starting air handle of the air tank.
 - 2 Open the drain valve handle located under the drain valve on the front side of the tank to drain accumulated water from the tank.
- Note: The amount of drained water can vary depending on the relative humidity and air consumption.
- 3 Close the drain valve handle after draining water.
 - 4 Open the starting air handles slowly.

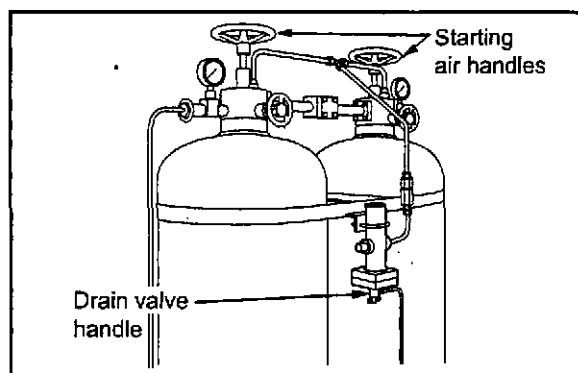

fig.6-32 Draining water from air tank

Inspection Safety Valve of Air Tank

Check to make sure the safety valve opens to relieve pressure when the air pressure in the tank rises abnormally.

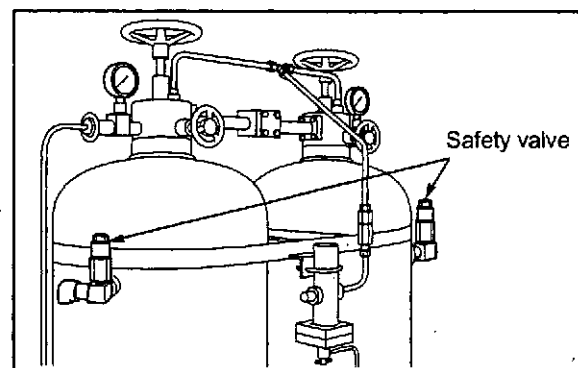

fig.6-33 Inspection safety valve of air tank

Draining Water from Air Starter Compressor

- 1 Check the starter valve handle of the air strainer tank.
- 2 Remove the drain plug and drain water from the air strainer compressor.
- 3 Install the drain plug after draining water.
- 4 Open the starter valve handle of the air starter tank slowly.

Note: The air compressor model and shape differ on the type of the engine.

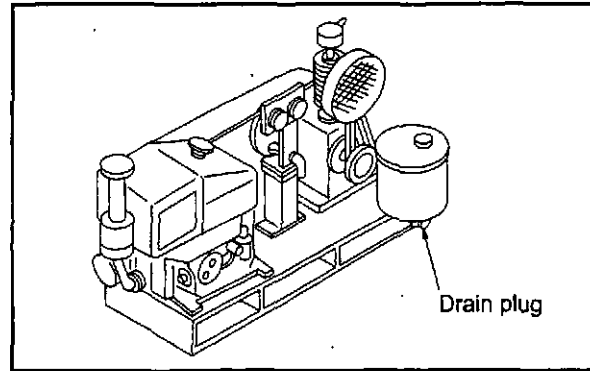

fig 6-34 Air starter compressor

Chapter 7

LONG-TERM STORAGE

Long-term storage

The following describes the method to store the engine in a non-operable condition for more than three months and the method for storing the engine in an operable condition for more than three months.

If the engine is not properly prepared for a long-term storage of more than three months, internal engine parts can rust and become damaged. Be sure to follow the directions below when storing the engine for an extended period of time.

Storing Engine in Non-operable Condition for More Than 3 Months Preparation for Storage

- 1 Drain engine oil, and pour rust-preventive oil (NP-10-1 to NP-10-3) into the engine.
- 2 Prepare a fuel mixture containing 50% rust-preventive oil (NP-9), and pour it into the fuel tank.
- 3 Operate the engine at a speed of 800 to 1000 min⁻¹ (idling) for 5 to 10 minutes under no load.
- 4 Immediately after stopping the engine, spray volatile corrosion inhibitor (V.C.I.) through the inlet side to prevent rust on the air intake system.
- 5 With the engine not in operation, drain the fuel mixture from the fuel tank.
- 6 Apply rust-preventive oil (NP-3) liberally on the exposed sections of the machine.
- 7 Seal air inlet, exhaust outlet, breather and other openings with adhesive cloth tape.
- 8 Loosen the V-belt.
- 9 Wrap adhesive cloth tape on the terminals of the starters and alternator, and seal the openings. Cover these sections with polyethylene sheet or processed polyethylene paper, and place desiccants in the polyethylene covers.
- 10 Disconnect cables from the battery terminals, and charge the battery. Clean the terminals, apply a thin coat of grease, and store them in a cool and dry room.
- 11 Cover the entire engine.

- Note:(a) Store the engine in a well-ventilated indoor location.
- (b) Coolant does not need to be drained since it contains long life coolant. (Add long life coolant to increase the concentration between 30 and 60%.)
- (c) Post a sign at an easily noticeable location to warn that the rust-preventive oil in the engine must be replaced with engine oil and the fuel tank must be filled with fuel before operating the engine.
- (d) New engine oil may be used in place of rust-preventive oil (NP-10-1 to NP-10-3).

Table 7-1 Recommended Rust-preventive Oil and Corrosion Inhibitor

JIS No.	Recommended product	Application
K2246	NP-3 Nippon Oil Corporation Anti Rust P-1400	Prevention of rust on exposed machine surfaces
	NP-9 Nippon Oil Corporation Anti Rust P-2100	Prevention of rust on fuel system
	NP-10-2 Nippon Oil Corporation Anti Rust P-230	Prevention of rust on lubricating system
Z1519	- Ryokou Kagaku V.C.I.Diana volatile corrosion inhibitor	Prevention of rust on air intake system

Maintenance during Storage

Charge the battery once a month.
After checking proper electrolyte level in the battery, charge the battery.

Using Engine after Storage

- 1 Remove the cover from the engine.
- 2 Connect a fully charged battery.
- 3 Remove the covers from the starters and alternator.
- 4 Adjust the tension of the V-belt.

Note: Regarding adjustment of V-belt tension, refer to "Inspection of V-belt and Adjustment of Belt Tension" (6-2).

- 5 Remove sealing tapes from the openings of the engine.
- 6 Drain rust-preventive oil, and pour appropriate engine oil.

Note: Regarding engine oil, refer to "Engine Oil" (4-4).

- 7 Fill the fuel tank with fuel, and bleed the fuel system.

Note: Regarding bleeding of the fuel system, refer to "Bleed the fuel system" (3-2).

- 8 Inspect all sections of the engine.
- 9 Remove the rocker covers, and pour oil on the valve mechanisms.
- 10 Crank the engine for about 10 seconds, and repeat the cranking operation 3 times at an interval of about 1 minute.

CAUTION

To crank the engine, shut off the fuel supply to the engine and operate the starters.

- 11 Make sure the engine oil pressure rises.

Starting the engine

- 1 Start the engine.

CAUTION

With regards to starting the engine, refer to "Preparations for Operation (Pre-Start Inspection)" (3-8).

- 2 Conduct a warm-up operation to circulate oil throughout the engine.
- 3 Apply load and increase the engine speed to the rated speed.

Storing Engine in Operable Condition for More Than 3 Months

When the engine is not operated during storage of more than three months, internal engine parts can rust and lose oil film. As a result, the engine can seize when it is started after storage. To prevent this, the engine must be operated periodically for maintenance purposes during storage.

Operating Engine for Maintenance Purposes

Operate the engine for maintenance purposes at least once a month by following the directions below.

- 1 With no fuel supplied to the engine (press the engine stop button to shut off fuel injection), operate the starters twice at intervals of about 15 seconds and check the engine oil pressure gage to make sure the oil pressure increases.
- 2 After the engine starts, operate under no load for 5 to 10 minutes.

Chapter 8

TRANSPORTATION

Lifting Engine Carefully

⚠ WARNING

To lift the engine, use wire ropes, shackles and slings capable of supporting the weight of the engine.

Attach slings to the hangers provided on the engine to lift the engine.

Keep the engine balanced during lifting by considering the engine's center of gravity. Keep the angle formed by slings attached to hangers within 60° . If the angle exceeds this limit, excessive load is applied on the hangers and may damage the hangers.

Attach wire ropes to the hanger after removing the pipe cover and the insulator near the hanger for lifting.

To prevent wire ropes from contacting the engine, place a cloth or other soft padding to prevent damage to the engine and wire ropes.

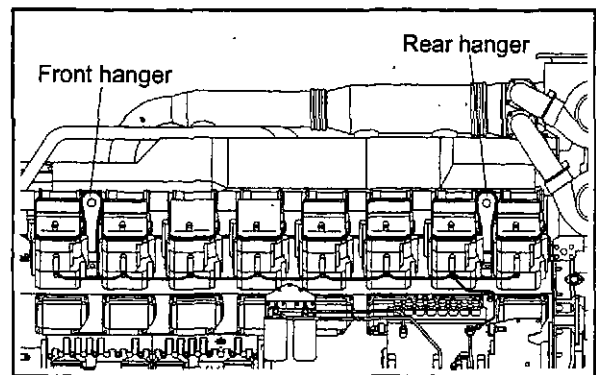

fig.8-1 Hangers for lifting

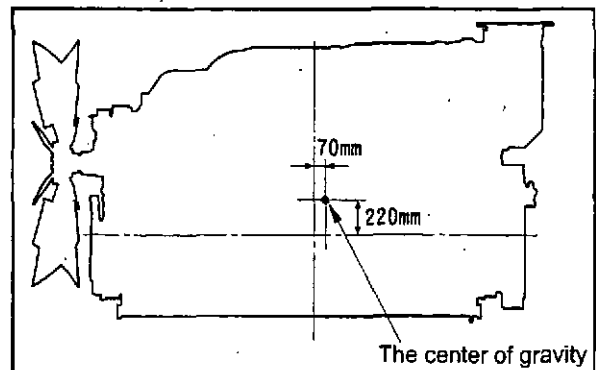

fig.8-2 The center of gravity for the engine

Chapter 9

TROUBLESHOOTING

General Precautions

Contact a Mitsubishi Dealer for Repair Service

Repairing a malfunctioning engine may require special equipment or potentially dangerous work, except for relatively simple procedures such as the change and addition of fuel, engine oil and coolant. In the event of the engine generates a malfunction, contact a Mitsubishi dealer.

Examination before Work

Before troubleshooting, examine possible causes of the problem and try to see if the same problem has occurred in the past.

Check the parts that may be causing the problem in the most efficient order.

When disassembling a component, pay close attention to the disassembly sequence so that you can reassemble the component efficiently.

Notes Regarding Contamination

Dust and foreign particles are the most common cause of rapid wear of parts.

When disassembling a component, take measures to prevent dust and foreign particles from entering the component being disassembled.

Notes Regarding Parts Handling

Handle parts carefully.

When replacing parts, use only genuine parts by referring to the parts catalog.

Work Safety

Be sure to use wrenches of correct size. Using a wrench of a wrong size not only damages nuts but can also cause personal injury.

Use correct tools and perform work with utmost caution.

Be sure to estimate the weight of the part being dismounted. If the removed part is too heavy, it may fall during lifting, causing damage to the part as well as personal injury.

How to Troubleshoot

Starters Do Not Crank or Crank Slowly, Resulting in Start Failure

Table 9-1 Starters Do Not Crank or Crank Slowly, Resulting in Start Failure

Problem	Cause	Remedy	
Start failure	Electrical system	Blown fuse	Change fuse.
		Faulty wire connection between battery and starter switch	Connect wire correctly.
		Faulty wire connection between battery, starters and starter switch	Connect wire correctly.
		Insufficiently charged battery	Inspect and adjust V-belt tension. Refer to "Inspection of V-belt and Adjustment of Belt Tension" (6-2).
		Specific gravity of battery fluid too low	Charge battery.
		Faulty battery	Install new battery.
		Faulty starter or starter relay	Consult a Mitsubishi dealer.
	Lubricating system	Oil viscosity too high	Use appropriate engine oil. Refer to "Engine Oil" (4-4).
	Fuel system	Air in fuel system	Bleed fuel system. Refer to "Fuel System" (3-1).
		Low fuel level	Add fuel.
		Clogged fuel filters	Change fuel filters. Refer to "Changing Fuel Filters" (6-5).
		Faulty fuel feed pump	Consult a Mitsubishi dealer.
		Faulty fuel injection pump	Consult a Mitsubishi dealer.
	Engine mechanical	Faulty moving parts (Interference between valves and pistons, or foreign items in cylinders)	Consult a Mitsubishi dealer.

Starters Crank, But Engine Does Not Start

Table 9-2 Starters Crank, But Engine Does Not Start

Problem	Cause	Remedy	
Engine does not start	Fuel system	Empty fuel tank	Add fuel, and bleed fuel system. Refer to "Fuel System" (3-1).
		Damaged fuel pipe	Consult a Mitsubishi dealer.
		Loose fuel pipe connection	Tighten connection. Consult a Mitsubishi dealer.
		Improper fuel	Use proper fuel. Refer to "Fuel" (4-2).
		Dust or water mixed in fuel	Remove dust or water from fuel tank. Refer to "Cleaning Fuel Tank" (6-4).
		Clogged fuel filters	Replace fuel filters. Refer to "Changing Fuel Filters" (6-5).
		Faulty fuel feed pump	Consult a Mitsubishi dealer.
		Faulty fuel injection pump	Consult a Mitsubishi dealer.
	Air intake system	Clogged air cleaner	Clean pre-cleaner. Refer to "Cleaning and Inspecting Air Cleaner Element" (6-12).
	Engine mechanical	Compression pressure low (damaged cylinder liner, piston or piston ring, or faulty valve seat or nozzle packing seal)	Consult a Mitsubishi dealer.

Other Problems and Countermeasures

Engine Output is Low

Table 9-3 Engine Output is Low

Cause	Remedy
Engine oil viscosity too high	Use engine oil of appropriate viscosity according to ambient temperature. Refer to "Engine Oil" (4-4).
Improper fuel	Use proper fuel. Refer to "Fuel" (4-2).
Insufficient air intake (clogged air cleaner)	Clean air cleaner element, or replace if necessary. Refer to "Cleaning and Inspecting Air Cleaner Element" (6-12).
Engine overcooling	Cover the radiator or consult a Mitsubishi dealer.
Clogged fuel filter	Replace fuel filters. Refer to "Changing Fuel Filters" (6-5).
Insufficient cooling (overheating)	Consult a Mitsubishi dealer.
Incorrect valve clearance	Consult a Mitsubishi dealer.
Faulty fuel feed pump	Consult a Mitsubishi dealer.
Faulty fuel injection pump	Consult a Mitsubishi dealer.
Faulty fuel injection nozzles	Consult a Mitsubishi dealer.
Incorrect fuel injection timing	Consult a Mitsubishi dealer.
Low compression pressure (worn cylinder liners, worn piston rings, etc.)	Consult a Mitsubishi dealer.

Exhaust Smoke is White or Blue

Table 9-4 Exhaust Smoke is White or Blue

Cause	Remedy
Excessive amount of engine oil	Maintain correct oil level. Refer to "Lubricating System" (3-4).
Engine oil viscosity too high	Use engine oil of appropriate viscosity according to ambient temperature. Refer to "Engine Oil" (4-4).
Overcooling	Cover the radiator or consult your Mitsubishi dealer.
Faulty thermostat (water temperature does not rise)	Consult a Mitsubishi dealer.
Faulty fuel injection nozzles (uneven injection among cylinders)	Consult a Mitsubishi dealer.
Incorrect fuel injection timing	Consult a Mitsubishi dealer.
Low compression pressure (worn piston liners, worn piston rings, etc.)	Consult a Mitsubishi dealer.
Improper fuel (low cetane number)	Use proper fuel. Refer to "Fuel" (4-2).

Exhaust Smoke Is Black or Dark Gray

Table 9-5 Exhaust Smoke is Black or Dark Gray

Cause	Remedy
Improper fuel	Use proper fuel. Refer to "Fuel" (4-2).
Incorrect valve clearance	Consult a Mitsubishi dealer.
Faulty fuel feed pump	Consult a Mitsubishi dealer.
Low compression pressure (worn piston liners, worn piston rings, etc.)	Consult a Mitsubishi dealer.
Insufficient intake air (improper ventilation, clogged air cleaner)	Clean air cleaner element, or replace if necessary. Refer to "Cleaning and Inspecting Air Cleaner Element" (6-12).
Incorrect fuel injection timing	Consult a Mitsubishi dealer.
Faulty fuel injection nozzles	Consult a Mitsubishi dealer.
Faulty fuel injection pump	Consult a Mitsubishi dealer.

Fuel Consumption is High

Table 9-6 Fuel Consumption is High

Cause	Remedy
Faulty fuel feed pump	Consult a Mitsubishi dealer.
Faulty fuel injection pump	Consult a Mitsubishi dealer.
Incorrect fuel injection timing	Consult a Mitsubishi dealer.
Improper fuel	Use proper fuel. Refer to "Fuel" (4-2).
Low compression pressure (worn piston liners, worn piston rings, etc.)	Consult a Mitsubishi dealer.
Insufficient intake air (improper ventilation, clogged air cleaner)	Clean air cleaner element, or replace if necessary. Refer to "Cleaning and Inspecting Air Cleaner Element" (6-12).

Engine Oil Consumption is High

Table 9-7 Engine Oil Consumption is High

Cause	Remedy
Excessive amount of engine oil	Maintain correct oil level. Refer to "Lubricating System" (3-4).
Engine oil viscosity too low	Use engine oil of appropriate viscosity according to ambient temperature. Refer to "Engine Oil" (4-4).
Engine oil leakage	Consult a Mitsubishi dealer.
Worn cylinder liners, worn piston rings	Consult a Mitsubishi dealer.
Worn valve stem seals	Consult a Mitsubishi dealer.

Engine Overheats

Table 9-8 Engine Overheats

Cause	Remedy
Radiator, heat exchanger leakage	Consult a Mitsubishi dealer.
Low coolant level	Add coolant.
Faulty water pump	Consult a Mitsubishi dealer.
Faulty thermostat	Consult a Mitsubishi dealer.

Engine Oil Pressure is Faulty

Table 9-9 Engine Oil Pressure is Faulty

Cause	Remedy
Insufficient amount of engine oil	Maintain correct oil level. Refer to "Lubricating System" (3-4).
Engine oil viscosity too low	Use engine oil of appropriate viscosity according to ambient temperature. Refer to "Engine Oil" (4-4).
Clogged oil filter	Replace oil filters. Refer to "Changing Engine Oil, Oil Filters and Bypass Oil Filter" (6-6).
Faulty oil pump	Consult a Mitsubishi dealer.
Faulty relief valve	Consult a Mitsubishi dealer.
Faulty oil pressure sensor	Consult a Mitsubishi dealer.

Note: (a) If the problem cannot be corrected easily or when a problem other than those listed above occurs, consult a Mitsubishi dealer.

(b) When ordering replacement parts, provide the engine serial number. When requesting repair, provide the engine serial number and service hour meter reading.

When Fuel Has Run Out

When fuel runs out during engine operation, causing the engine to stop, follow the procedures below to restart the engine.

- 1 Return the starter switch to the OFF position.
- 2 Add fuel to the fuel tank.

Note: Regarding filling of the fuel tank, refer to "Draining Water from Fuel Tank" (3-9).

- 3 Bleed the fuel system.

Note: Regarding bleeding of the fuel system, refer to "Bleed the fuel system" (3-2).

- 4 Restart the engine.

Note: Regarding starting of the engine, refer to "Preparations for Operation (Pre-Start Inspection)" (3-8).

Chapter 10

MAIN SPECIFICATIONS

Main Specifications

Table 10-1 Main Specifications Table

Engine model	S16R
Type	Water-cooled 4-stroke cycle, turbocharged diesel, air cooler
Number of cylinders, arrangement	16-V
Bore x Stroke (mm [in.])	170 x 180 [6.70 x 7.10]
Total displacement (L [cu.in.])	65.37 [3985]
Combustion type	Direct injection
Compression ratio	14.0:1(TA,TK) 13.5:1(TA-2,TK-2)
Firing order	1-9-6-14-2-10-4-12-8-16-3-11-7-15-5-13
Rotation direction	Counterclockwise as viewed from flywheel
Dimensions (L x W x H (mm) [in.])	Approx. 2875[113.19]x1360[53.58]x1810[71.26]
Dry weight (kg [lb.])	Approx. 6200[13668]
Fuel	Diesel fuel
Fuel injection pump	Mitsubishi PS8 type x 2
Fuel filter	Cartridge-type paper element, spin-on type
Fuel injection nozzle	Hole type
Initial fuel injection pressure (MPa (kgf/cm ²) [psi])	34.3 (350) [4979]
Lubricating system	Forced circulation type (pressure feed by oil pump)
Lubrication oil	Class CD or CF oil (API service classification)
Engine oil capacity (liter [U.S.gallon])	Oil pan: Approx.200 [52.83] Whole engine:Approx.250[66.05]
Oil filter	Paper element (equipped with bypass filter, spin-on type)
Oil cooler	Water cooled multi-plate (equipped with crankcase)
Cooling system	Force water cooling
Cooling water capacity (liter [U.S. gallon])	Approx.170 [44.91] (in engine only)
Starting system	Electrical start (air motor type or direct air type) (only for type-1)
Starter	24 V - 7.5 kW x 2
Alternator	24 V - 30 A
Turbocharger	Mitsubishi TD13 or TD10 x 4

