



Nissan Engine Operator Manual

Dependable Power Solutions . . . It's All We Do!

100 Power Drive Mankato, MN 56001
Phone 507.625.7973 Fax 507.625.2968 Toll Free 800.325.5450 www.mtu-online.com

Forward

This booklet has been prepared to provide the necessary information for the operation, inspection and maintenance of the Nissan Engine.

We urge you to follow the recommendations contained in this booklet so that the Nissan Engine will remain free of trouble throughout its working life. Please familiarize yourself with the booklet and refer to it when necessary.

If you encounter any problems with your Nissan Engine contact the authorized MTU Onsite Energy service dealer in your area.

All information, specifications and illustrations in this manual are on a basis of the latest data obtainable at the time of the publication. MTU Onsite Energy reserves the right to make changes or improvements at any time without notice.

Contents

Forward	2
Contents	2
Operation	3
Other Handling and Operations	4
Daily Care	7
IC Ignition System	14
Trouble Diagnosis and Corrections	16
Recommended Lubricant	21
Engine Serial Number	23
Service Data and Specifications	24

Operation

HANDLING OF NEW ENGINE

The life and performance of an engine are greatly influenced by how it is handled and serviced during the initial period.

Operate the engine by observing the following precautions during the initial 100 hours of operation.

Cautions in operation

1. Prior to starting, engine block heaters need to be on and working properly.
2. Always maintain the operation speed of 1800 rpm.
3. Do not overload the engine.

Starting the engine

1. Before starting, check the engine oil and coolant level and fill or add if necessary.
2. Visually check the engine for leaks, loose belt or foreign objects that may interfere with operation.
3. Check instrumentation for proper oil pressure (above 30 psi).

During engine operation

1. During operation, always make sure that the cooling water temperature and lubricating oil pressure are both within normal operating range. Normal cooling water temperature is 167 to 210°F and oil pressure is 30-75 psi.
2. Always be aware of the condition of the engine, paying attention to any abnormal vibration, noise or other unusual circumstances. If any abnormality is found, immediately stop the operation, examine the cause, and make the necessary correction.

Stopping the engine

Stopping the engine immediately after heavily loaded operation will deteriorate the engine and/or may cause high engine temperature alarm to activate because it is still in a very hot state. If high engine temperature alarm activates, the unit will not restart until alarm is manually cleared.

Upon completion of operation, allow engine to cool down; recommended cool down time is 5 minutes.

Periodic inspections

Perform periodical inspection and replacement of the following items: engine oil, oil filter, air cleaner element, fuel filter element, radiator, coolant level, and coolant quality. Follow maintenance schedule found later in this manual.

Other Handling and Operations

COLD AND HOT WEATHER OPERATION

In cold weather

- **Oil**

Use engine oil suitable for ambient temperature.

- **Coolant**

Mix coolant to a 50/50 mixture for proper and safe operation of the cooling system. Refer to chart for proper freezing point of mixture.

Coolant capacity (Engine proper):

3.5 lit. (3.70 US qt., 3.07 Imp qt)

Coolant mixture ratio

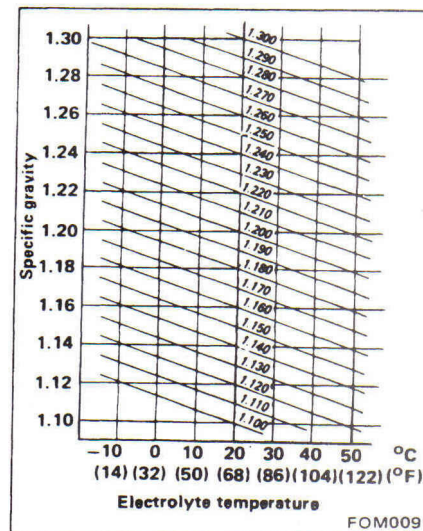
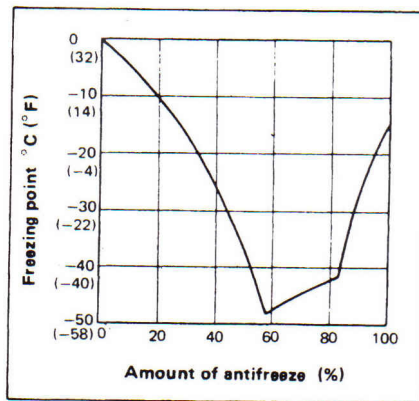

- **Battery**

Battery should not be left in discharged state. When battery performance becomes questionable, check the specific gravity of the electrolyte, terminals of battery and alternator for belt tension, as well as battery charger for proper operation.

The normal specific gravity is 1.260 as corrected at 20°C (68°F). It changes approximately 0.0007 for every 1°C (1.8°F). If the specific gravity for electrolyte does not reach the desirable value, charge the battery soon. Be sure to disconnect the battery charger before removing battery cables.

PROCEDURES FOR PLACING THE ENGINE IN LONG-TERM STORAGE

Before storing the engine for a long period of time (more than six months), perform the following procedures to prevent formation of rust. If the storage period is short, follow the maintenance procedures for the engine as described in the previous paragraph.

Lubricating system

Drain the engine oil, pour the specified amount of rust preventive oil into the oil pan, and then run the engine under no load at approximately 1800 rpm for about 10 minutes. Stop the engine, and seal all the openings of the lubricating system with sealing tape.

For a greater rust preventing effect, perform this operation in combination with the rust preventing procedure for the fuel system and cooling system.

Cooling system

Flush the cooling system and pour antifreeze or an anti-rust agent into the cooling water. Run the engine under no load at 1800 rpm for about 10 minutes. Stop the engine, and seal all of the openings in the cooling system (such as overflow pipe, etc.) with sealing tape. If antifreeze is used, keep the cooling water in the system. If an anti-rust agent is used, thoroughly drain the cooling water before sealing.

When using antifreeze, pay attention to the freezing point of coolant and choose a mixing ratio of at least 30%; a mixing ratio of less than 30% provides only a limited rust preventing effect. Note that the anti-rust agent will freeze when the temperature falls below 0°C (32°F). In such event, either thoroughly drain the cooling water or use antifreeze.

Combustion chamber

After completing the rust preventive procedure, allow the engine temperature to drop to room temperature. Then disconnect the air cleaner from the carburetor and spray or pour rust preventing oil into the combustion chamber. Next, disconnect cables and crank the engine five to ten times, and then reinstall the spark plug cables.

Engine exterior

Using a petroleum solvent, remove dirt and oil from the uncoated metal surfaces of the engine (intake manifold, exhaust manifold, rocker cover, fan belt grooves of pulleys, etc.). Spray or apply anti-rust agent to the cleaned surfaced. Do not apply any antirust agent to the fan and belt grooves of pulleys.

Others

1. Loosen fan belt.
2. Seal the air intake hole of the air cleaner and air outlet hole of the exhaust tube with adhesive tape.
3. When storing the engine as a complete assembly outdoors, cover it fully with a porous water-proof bag. Do not use a vinyl bag because it lacks porosity and retains water inside.

Preparations for operation after long-term storage

1. Remove all adhesive sealing tapes from the openings of the engine.
2. Drain the rust preventing oil and anti-rust agent by using the following procedure, and replace it with the specified amount of engine oil, fuel and cooling water.

- a. Lubricating system:
Drain oil through the drain plug of oil pan and oil filter.
 - b. Cooling system:
If antifreeze is used, drain cooling water from the drain valves on the radiator and cylinder block and flush the cooling system. If an anti-rust agent is used, flush the cooling system. Refill 50/50 with coolant and distilled water. Plug in block heater and allow coolant to warm up.
 - c. Exterior of engine:
Clean the exterior surfaces of the engine with a petroleum solvent (Trichlene).
3. Replace oil filter and air cleaner.
 4. Adjust the fan belt for proper tension.
 5. Check and adjust valve clearance. Apply engine oil to the rocker arm and other valve mechanism.
 6. Check the battery electrolyte level and specific gravity. Refill and/or recharge if it is necessary.
 7. Before the engine starts, disconnect the spark plug cables from spark plugs.
 8. Crank the engine for about 10 seconds. Repeat this cranking operation two or three times in order to disperse engine oil to every portion of the engine, and then install the spark plug cables.
 9. Start the engine unloaded and run at 1800 rpm for about 15 minutes.
 10. Make sure that the oil pressure is operating in the safe range and coolant temperature is normal, and that the engine does not produce any abnormal vibration or noise.

Daily Care

In order to prevent trouble during operation, it is necessary that the operator be aware of the condition of the engine. To achieve this awareness, the operator must inspect the engine during routine maintenance.

If you note any defects, notify your authorized MTU Onsite Energy dealer.

CHECK ENGINE OIL LEVEL

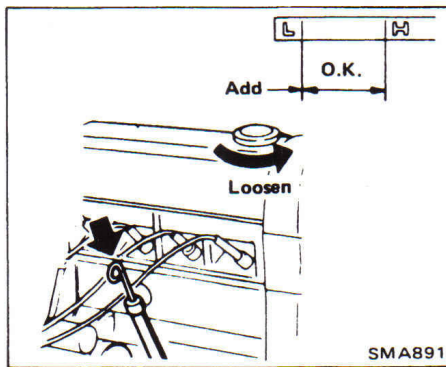

To check the oil level, pull out the dip stick, wipe it clean and reinsert it; remove it again to read the oil level. The level should be between the “L” and “H” marks.

CHECK COOLING LEVEL

Remove the radiator cap and check the coolant level. Also check the cap and determine if it functions correctly. The coolant level is correct if it is near to the filler neck of radiator. Insufficient coolant level may be caused by leakage from the engine radiator or overflow reservoir. Check carefully for any sign of leakage; if no leaks are discovered, add coolant through the filler neck portion of the radiator and add as needed to overflow reservoir.

CHECKING THE ENGINE FOR LEAKAGE

1. Insure that the engine, radiator and hoses are not leaking.
2. Check each portion of the engine and make sure that there is no sign of an oil leak.
3. Check the fuel system to make sure that all connections are firmly tightened.

ENGINE MAINTENANCE SCHEDULE – NISSAN MODEL H20 - H25

The following table lists the periodic maintenance required to ensure quality performance and good mechanical conditions of the Engine and Fuel Systems for your generator set.

MAINTENANCE OPERATION

Periodic maintenance should be performed after specified intervals have elapsed in hours or annually, whichever comes first.	250 hrs.	500 hrs.	750 hrs.	1000 hrs.	1250 hrs.	1500 hrs.	1750 hrs.	2000 hrs.	2250 hrs.	2500 hrs.	Annual
1. Intake & exhaust valve clearances (operating temperature)	I	I	I	I	I	I	I	I	I	I	I
2. Drive belt tension	I	I	I	I	I	I	I	I	I	I	I
3. Cylinder head bolts & manifold nuts	T	I	I	I	I	I	I	I/T	I	I	I/T
4. Radiator	I/C	I/C	I/C	I/C	I/C	I/C	I/C	I/C	I/C	I/C	I/C
5. Engine oil	R	R	R	R	R	R	R	R	R	R	R
6. Oil filter	R	R	R	R	R	R	R	R	R	R	R
7. Air cleaner element	I	I/R	I	I/R	I	I/R	I	I/R	I	I/R	I
8. Ignition timing (LPG & NG)	I	I	I	I	I	I	I	I	I	I	I
9. Spark plugs	I	I/R	I	I/R	I	I/R	I	I/R	I	I/R	I
10. Distributor inside (IC ignition system)	I	I	I	I	I/C	I	I	I	I	I/C	I
11. Charging system – engine alternator	I	I	I	I	I	I	I	I	I	I	I
12. Battery	I	I	I	I	I	I	I	I	I	I	R
13. Fuel line supply and connectors portion for LPG and NG leakage	I	I	I	I	I	I	I	I	I	I	I
14. Fuel line supply and connectors for damage	I	I	I	I	I	I	I	I	I	I	I
15. Strainer (optional)	I/C	I/C	I/C	I/C	I/C	I/C	I/C	I/C	I/C	I/C	I/C
16. LPG/NG manual shutoff lock off (optional)	I	I	I	I	I	I	I	I	I	I	I

Abbreviations:

- I = Inspection**
- R = Replace**
- C = Clean**
- D = Drain**
- T = Retighten**

MAINTENANCE OPERATION

MTU Onsite Energy recommends the following maintenance be performed by trained and certified representatives.

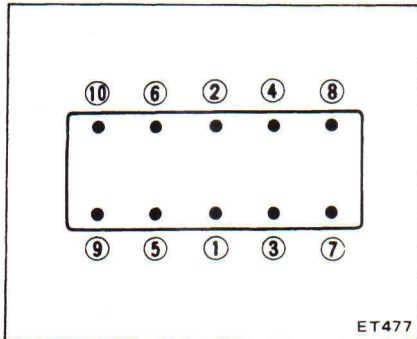

Retightening cylinder head nuts, manifold bolts and nuts.

Cylinder head bolts

When the engine is cold, retightening should be made in the sequence shown.

Required Torque: **Cylinder head bolt**
H20 - H25
78 to 93 N M
(8.0 to 9.5 kg-m,
58 to 69 ft-lb)

Required Torque: **Manifold nuts**
14 to 18 N m
(1.4 to 1.8 kg-m,
10 to 13 ft-lb)

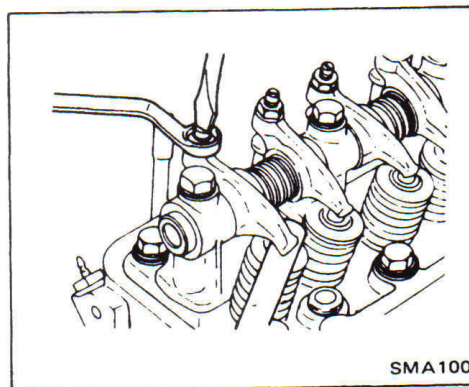
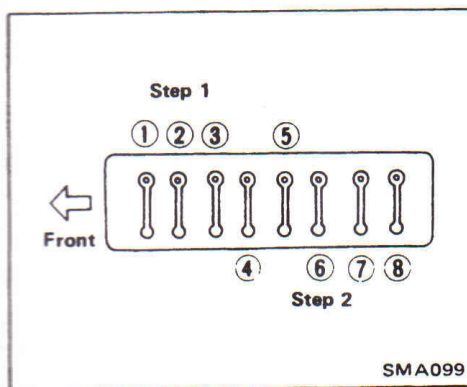

Adjusting intake and exhaust valve clearance

Adjustment should be made while engine is warm but not running.

1. Start engine and warm it up, sufficiently. Then turn off engine.
2. Remove valve rocker cover.
3. Rotate crankshaft.

(1) Set No. 1 cylinder in top dead center on its compression stroke and adjust valve clearances.

(2) Set No. 4 cylinder in top dead center on its compression stroke and adjust valve clearances.

Valve clearance (Hot):

Intake & exhaust:

0.35 mm (0.015 in)

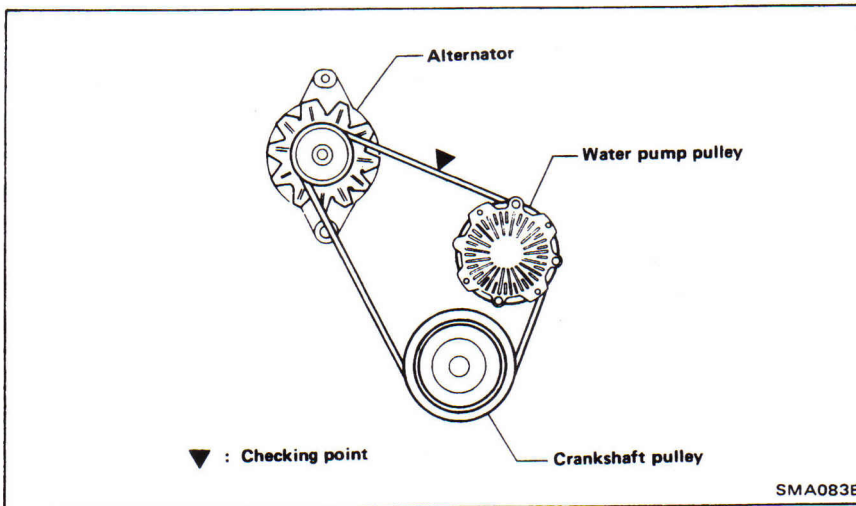

CHECKING AND ADJUSTING DRIVE BELTS

1. Visually inspect for cracks, fraying, wear or oiliness. The belts should not touch the bottom of the pulley groove.
2. Check belt tension by pushing midway between pulleys.

Drive belt deflection:

8 to 12 mm (0.31 to 0.47 in)

Pushing force:

98 N (10 kg. 22 lb)

Changing engine oil and oil filter

1. Start engine and warm up engine sufficiently, then stop engine.
2. Remove oil filter cap and oil pan drain plug, and allow oil to drain.

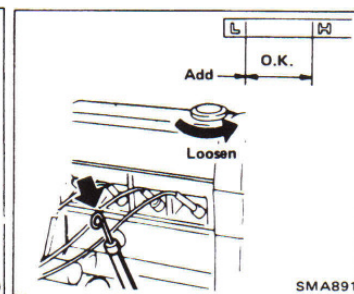
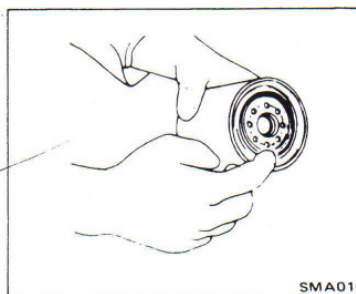
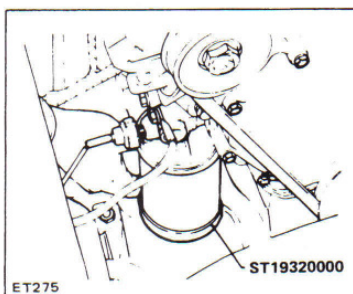

WARNING:

Be careful not to burn yourself, as the engine oil may be hot.

- **A milky oil indicates the presence of cooling water; isolate the cause and take corrective measure.**
- **An oil with extremely low viscosity indicates dilution with fuel.**

3. Clean and install oil pan drain plug with washer.

Required Torque: **Oil pan drain plug**
 20 to 28 N m
 (2.0 to 3.0 kg-m, 14 to 22 ft-lb)

Oil Filter

MTU Onsite Energy Part Number: 76420

4. Using filter wrench, remove oil filter.
5. Wipe oil filter mounting surface with a clean rag.
6. Smear a little engine oil on rubber gasket of new oil filter and fill filter with oil.
7. Install new oil filter. Handtighten ONLY. DO NOT use a wrench to tighten the filter.
8. Refill engine with new recommended engine oil, referring to Recommended Lubricants. Check oil level with dipstick.

Oil Capacity:

	Unit: liter (US qt., Imp qt)
With oil filter	3.8 (4.0, 3.34)
Without oil filter	3.5 (3.70, 3.07)

9. Start engine. Check area around drain plug and oil filter for any sign of oil leakage. If any leakage is evident, these parts have not been properly installed.
10. Warm up engine sufficiently. Then stop engine and wait a few minutes. Check oil level. If necessary, add engine oil.

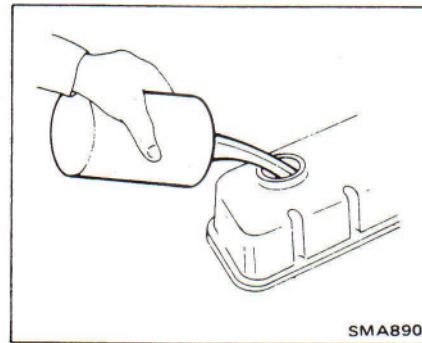

Changing engine coolant

WARNING:

To avoid the danger of being scalded, never attempt to change the coolant when the engine is hot.

When using antifreeze coolant, mix the antifreeze coolant with distilled water, observing instructions attached to antifreeze container.

Cleaning radiator

Clean inside of radiator with dry compressed air.

Checking cooling system, hoses and connections.

Check hoses and fittings for loose connections or deterioration. Retighten or replace hoses and clamps if necessary.

MTU Onsite Energy recommends that the following service be performed by a trained and certified technician.

Checking engine compression pressure

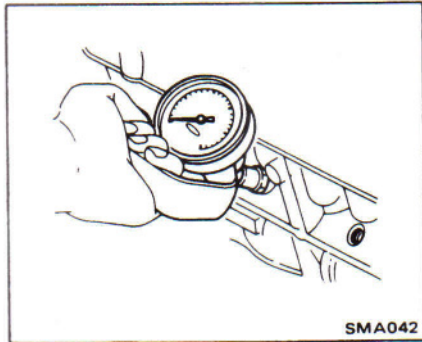

1. Warm up engine sufficiently, then stop engine.
2. Remove all spark plugs.
3. Properly attach a compression tester to spark plug hole in cylinder being tested.
4. Set carburetor throttle butterfly at fully-open position.
5. Crank engine and read gauge indication. Engine compression measurement should be made as quickly as possible.

Compression pressure:

Standard

1,275 kPa (12.75 bar, 13.0kg/cm², 185 psi)/300 rpm

Minimum

1,079 kPa (10.79 bar, 110.0 kg/cm², 158 psi)/300 rpm

6. Cylinder compression in cylinders should not be less than 80% of the highest reading. If cylinder compression in one or more cylinders is low, pour a small quantity of engine oil into cylinders through the spark plug holes and retest compression.
 - If adding oil helps the compression pressure, chances are that piston rings are worn or damaged.
 - If pressure stays low, valve may be sticking or sealing improperly.
 - If cylinder compression in any two adjacent cylinders is low, and if adding oil does not help the compression, there is leakage past the gasketed surface.
 - Oil and water in combustion chambers can result from this problem.

Checking fuel lines (Hoses, piping, connections, etc.)

Check fuel lines for proper attachment, leaks, cracks, damage, loose connections, chaffing and deterioration. If necessary, replace any damaged or defective parts.

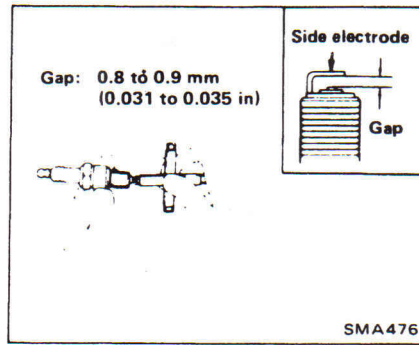
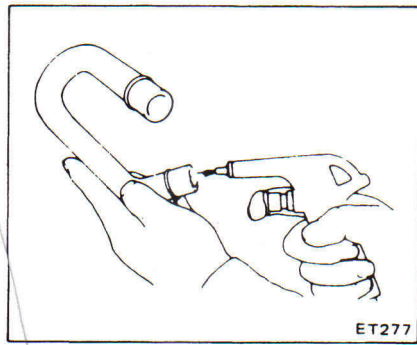

Cleaning and replacing air cleaner element (Dry paper type)

1. Remove air cleaner and blow dust off inner side of element with dry compressed air. **Be careful not to drop dirt into carburetor.**
2. Install air cleaner.

Checking crankcase ventilation hose

1. Check hoses and hose connections for leaks.
2. Check each hose for cracks or distortion.
3. Disconnect all hoses and blow them out with dry compressed air. If any hose cannot be made free of obstructions, replace with a new one.

Checking and replacing spark plugs

1. Disconnect the high tension cables from spark plugs. **Do not pull on the cable.**
2. Remove spark plugs with spark plug wrench.
3. Clean plugs in sand blast cleaner.
4. Inspect insulator for cracks or chips, gasket or damage or deterioration and electrode for wear or burning. If they are excessively worn, replace with new ones.
5. Check spark plug gap (see above diagram SMA476).

Spark plug type: Reference Parts Manual

IC Ignition System

IC IGNITION SYSTEM TROUBLE-SHOOTING

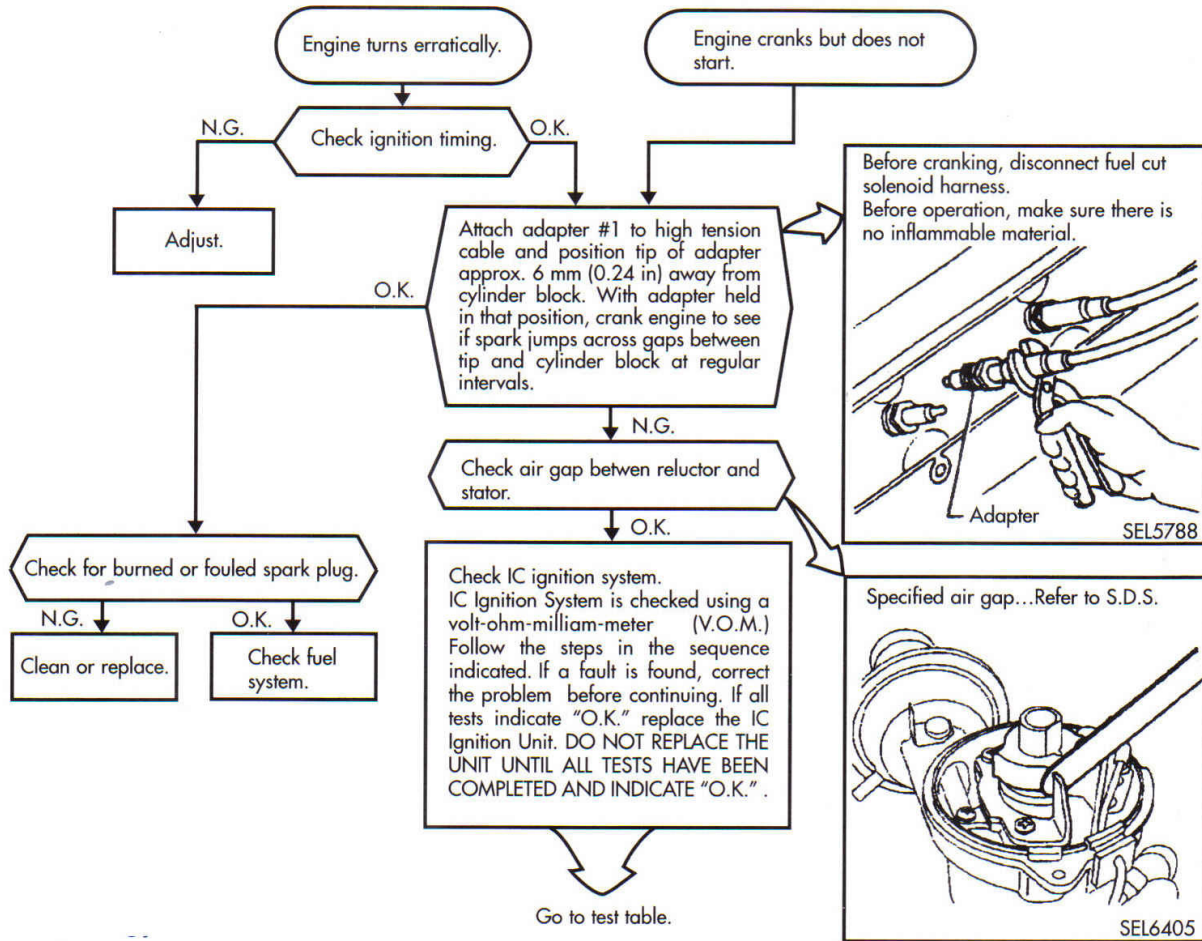

When current is flowing, never touch with bare hand high tension cables or any other parts with high voltage. If parts are moist, touching them could cause an electric shock, even if they are insulated. Always wear dry, well-insulated gloves or wrap affected parts with dry cloth before handling.

NOTE:

1. When performing the following tests, use a multimeter which can measure accurately in the following ranges; 0 to 20V D.C.; 0 to 1,000Ω; 0 to 10V A.C.; 0 to 50,000Ω.
2. If possible, start the generator and let it run for 5 to 15 minutes. This will bring all components to normal operating temperature, and will make it easier to diagnose intermittent problems.
3. It is not necessary to disconnect the harness connectors when performing the tests which follow. Simply insert the motor probes into the back of appropriate connector cavity.

BATTERY MAINTENANCE

Checking electrolyte level

Check the fluid level in each filler. If necessary, add only distilled water. Replace battery annually.

Do not overfill.

Checking electrolyte gravity

1. Place the hydrometer in the cell. Be sure the float is not in contact with the cylinder wall.
2. Take in enough electrolyte into the hydrometer to allow the float to suspend freely between the top and bottom of the cylinder.
3. Read indication.

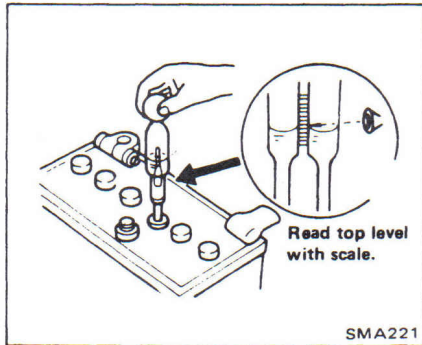

Battery:
MTU Onsite Energy Part Number: 74112

	Permissible value	Fully charged value [at 20°C (68°F)]
Other climates	Over 1.20	1.26
Frigid climate	Over 1.22	1.28
Tropical climate	Over 1.18	1.24

Trouble Diagnosis and Corrections

Condition	Probable cause	Corrective Action
Cannot crank engine or slow cranking	Improper grade oil Partially discharged battery Malfunctioning battery Loose alternator belt Trouble in charging system Wiring connection trouble in starting circuit Blown fuse Malfunctioning starting motor	Replace with proper grade oil Charge battery Replace Adjust Inspect Correct Replace Repair or replace
Engine will crank normally but will not start	In this case, the following trouble causes may exist, but in many cases ignition system or fuel system is in trouble. Ignition system in trouble Fuel system in trouble (low fuel, low fuel psi, low fuel volume) Valve mechanism does not work properly Low compression	Check spark plug firstly by following procedure. Disconnect high tension cable from one spark plug and hold it about 10 mm (0.39 in) from the engine metal part and crank the engine. Fill fuel, check fuel psi with gauge, check fuel volume.
Ignition system out of order	Disconnection of high tension cable Loose connection or disconnection in primary circuit	Replace Repair or replace
Fuel system out of order	Faulty governor Faulty or dirty magnetic pickup unit (mpu)	Must be 7" to 11" WC 4-6 oz. Check resistance
Low compression	Incorrect spark plug tightening or faulty gasket Improper grade engine oil or low viscosity Incorrect valve clearance Compression leak from valve seat Sticky valve stem Weak or damaged valve springs Compression leak at cylinder head gasket	Tighten to normal torque or replace gasket Replace with proper grade oil Adjust Remove cylinder head and lap valves Correct or replace valve and valve guide Replace Replace gasket

Condition	Probable cause	Corrective Action
	Sticking damaged piston ring Warm piston ring or cylinder (Trouble-shooting procedure) Inject a small quantity of engine oil in spark plug hole, and then measure cylinder compression Compression increases Compression does not change	Replace piston rings Overhaul engine Malfunctioning cylinder or piston ring Compression leaks from valve, cylinder head or head gasket
Others	Incorrect valve clearance Extremely low revolution Malfunctioning of the ignition system (spark plug, high tension cable, ignition coil, etc.) Incorrect basic ignition timing Faulty P.C.V. valve Clogged air cleaner filter Loose manifold and cylinder head bolts	Adjust Adjust Replace Adjust Replace Replace air cleaner filter Retighten bolts
Improper Engine Speed (Low)	Fuel pressure Low volume Bent butterfly Stuck fuel solenoid	Check 7-11" WC 4-6 oz NG = 270 cfh, LP = 173 cfh Replace Replace
Improper Engine Speed (High)	Fuel pressure Faulty L Series Governor Faulty magnetic pickup unit or control setting Bent butterfly	Check 7-11" WC 4-6 oz. Refer to governor manual Check resistance Replace
Others	Incorrect valve clearance Extremely low revolution Malfunction of the ignition system (spark plug, high tension cable, ignition coil, etc.) Incorrect basic ignition timing Faulty P.C.V. valve Clogged air cleaner filter	Adjust Adjust Replace Adjust Replace Replace air cleaner filter

Condition	Probable cause	Corrective Action
	Loose manifold and cylinder head bolts	Retighten bolts
Engine Power Not Up To Normal	Low compression	Previously mentioned.
Ignition system out of order	Incorrect ignition timing	Adjust
	Damaged spark plugs	Clean, adjust or replace plugs
Fuel system out of order	Clogged fuel pipe or strainer, fuel psi switch, manual shut off valve (optional)	Clean
Air intake system out of order	Clogged air cleaner	Clean or replace filter
	Air inhaling from manifold gasket or throttle body gasket	Replace gasket
	Faulty P.C.V. valve	Replace
Overheating	Insufficient coolant	Replenish
Intake louver blocked recirculating hot air	Loose fan belt	Adjust fan belt
Exhaust air opening blocked	Worn or oiled fan belt	Replace
	Inoperative thermostat	Replace
	Worn water pump	Replace
	Clogged or leaky radiator	Flush, repair or replace
	Faulty radiator filter cap	Replace
	Air in cooling system	Retighten each part of cooling system
	Improper engine oil grade	Replace with proper grade oil
	Incorrect ignition timing	Adjust
Overcooling	Inoperative thermostat	Replace
Noisy Engine Engine knocking	Overloaded engine	Use right gear in driving
	Carbon knocking	Disassemble cylinder head and remove carbon
	Timing knocking	Adjust ignition timing
	Fuel knocking	Use specified octane fuel
Mechanical knocking Crankshaft bearing	Pre-ignition (misusing of spark plug)	Use specified spark plug
	This strong dull noise increases when engine is accelerated. To locate the place, cause a misfire in each cylinder. If the noise stops by the misfire, this cylinder generates the noise.	This is caused by worn or damaged bearings, or unevenly worn crankshaft. Renew bearings and adjust or change crankshaft. Check lubrication system.
Connecting rod bearing knocking	This is a little higher-pitched noise than the crankshaft knocking, and also increases when engine is accelerated. Cause a	Same as the case of crankshaft bearings

Condition	Probable cause	Corrective Action
	misfire in each cylinder and if the noise diminishes almost completely, this crankshaft bearing generates the noise.	
<p>Mechanical knocking Piston cylinder noise</p> <p>Piston pin noise</p> <p>Water pump noise</p> <p>Others</p>	<p>When you hear an overlapping metallic noise which increases its magnitude with the revolution of engine and which decreases as engine is warmed up, this noise is caused by piston and cylinder. To locate the place, cause a misfire in each cylinder.</p> <p>This noise is heard at each highest and lowest dead end of piston. To locate the place, cause a misfire in each cylinder.</p> <p>This noise may be caused by worn or damaged bearings, or by the uneven surface of sliding parts</p> <p>An improper adjustment of valve clearance</p> <p>Noise of timing chain</p> <p>An excessive end play on crankshaft</p>	<p>This may cause an abnormal wearing of cylinder and lower compression which in turn will cause a lower out-put power and excessive consumption of oil.</p> <p>Overhaul engine.</p> <p>This may cause a wear on piston pin, or piston pin hole. Renew piston and piston pin assembly.</p> <p>Replace water pump with a new one</p> <p>Adjust</p> <p>Adjust the tension of chain</p> <p>Disassemble engine and renew main bearing</p>
<p>Abnormal combustion (Backfire, afterfire, run-on, etc.)</p> <p>Improper ignition timing</p> <p>Fuel system out of order</p> <p>Faulty cylinder head, etc.</p>	<p>Improper ignition timing</p> <p>Improper heat range of spark plugs</p> <p>Damaged throttle body or manifold gasket (backfire afterfire)</p> <p>Improperly adjusted valve clearance</p> <p>Excess carbon in combustion chamber</p> <p>Damaged valve spring (backfire, afterfire)</p>	<p>Adjust</p> <p>Use specified spark plugs</p> <p>Replace them with new parts</p> <p>Adjust</p> <p>Remove head and get rid of carbon</p> <p>Replace it with a new one</p>
<p>Excessive oil consumption</p> <p>Oil leakage</p> <p>Excessive oil consumption</p>	<p>Loose oil drain plug</p> <p>Loose or damaged oil pan gasket</p> <p>Loose or damaged chain cover gasket</p> <p>Worn oil seal in front and rear of crankshaft</p> <p>Loose or damaged rocker cover gasket</p>	<p>Tighten it</p> <p>Renew gasket or tighten it</p> <p>Renew gasket or tighten it</p> <p>Renew oil seal</p> <p>Renew gasket or tighten it (but not too much)</p>

Condition	Probable cause	Corrective Action
	Improper tightening of oil filter	Renew gasket and tighten it with the proper torque
	Loose or damaged oil pressure switch	Renew oil pressure switch or tighten it
	Cylinder and piston wear	Overhaul cylinder and renew piston
	Improper location of piston ring gap or reversely assembled piston ring	Remount piston rings
	Damaged piston rings	Renew rings. Repair or renew piston and cylinder
	Worn piston ring groove and ring	Renew piston and piston ring
	Fatigue of valve oil seal lip	Replace seal lip with a new one
	Work valve stem	Renew valve or guide
Others	Inadequate quality of engine oil	Use the designated oil
	Engine overheat	Previously mentioned
	Malfunction of P.C.V. system	Check or replace
Trouble in other functions		
Decreased oil pressure	Improper grade oil	Replace with proper grade oil
	Overheat	Previously mentioned
	Malfunctioning oil pump regulator valve	Disassemble oil pump and repair or replace it
Decreased oil pressure	Functional deterioration of oil pump	Repair or replace it with a new one
	Blocked oil filter	Replace with a new one
Excessive wear on the sliding parts	Increased clearance in various sliding parts	Disassemble and replace the worn parts with new ones
	Blocked oil strainer	Clean it
	Malfunctioning oil gauge pressure switch	Replace it with a new one
Scuffing of sliding parts	Oil pressure decreases	Previously mentioned
	Damaged quality or contamination of oil	Exchange the oil with proper one and change oil filter
	Clogged air cleaner filter	Clean or replace filter
	Overheat or overcool	Previously mentioned
	Improper fuel mixture	Check the fuel system

Condition	Probable cause	Corrective Action
	Decrease of oil pressure	Previously mentioned
	Insufficient clearances	Adjust to the sufficient clearances
	Overheat	Previously mentioned
	Improper fuel mixture	Check the fuel system
	Improper ignition timing	Adjust

Recommended Lubricant

LUBRICANT

Lubricant	Specifications	Remarks
LP/Natural Gas	API SD or SE	For further details, refer to the recommended SAE viscosity chart.
Antifreeze	-	Ethylene glycol base

SAE VISCOSITY NUMBER

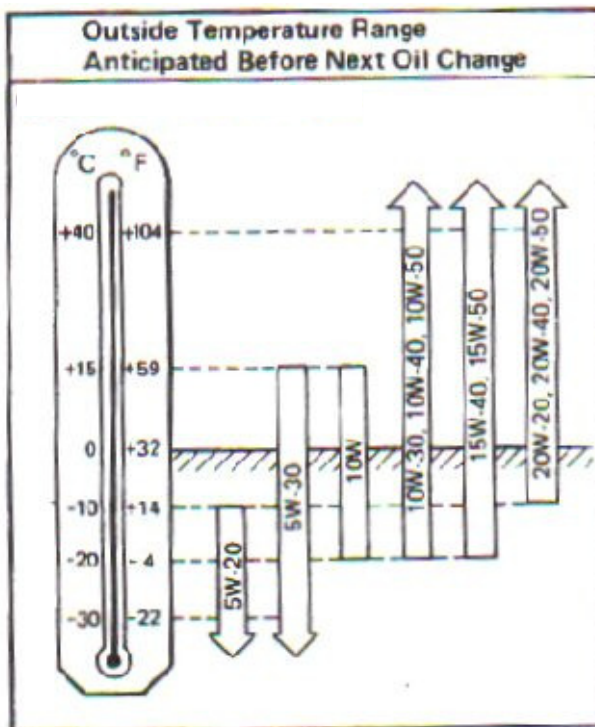

LUBRICATION SYSTEM DIAGRAM

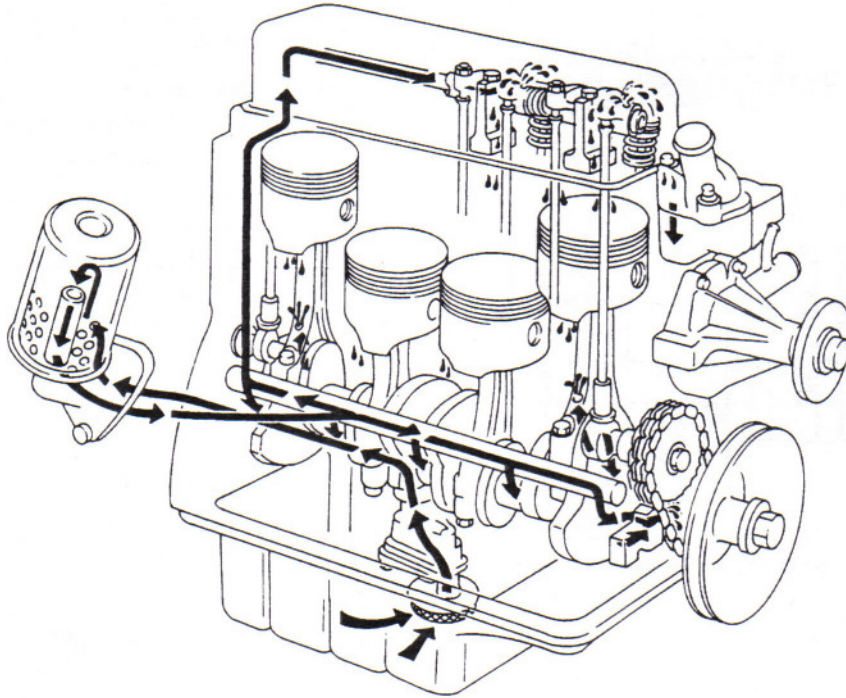

COOLING SYSTEM DIAGRAM

Cooling Circuit

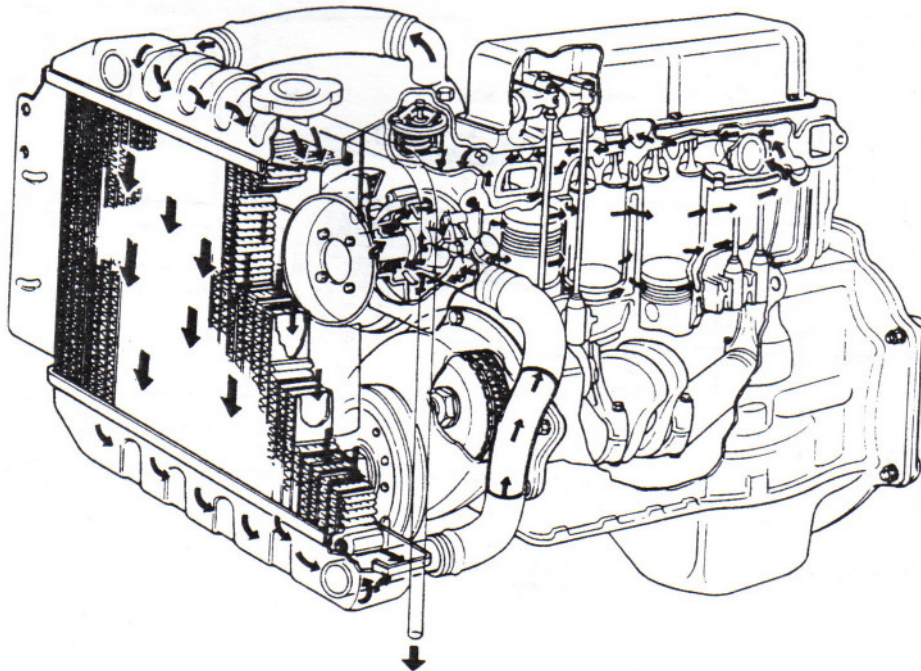

Engine Serial Number

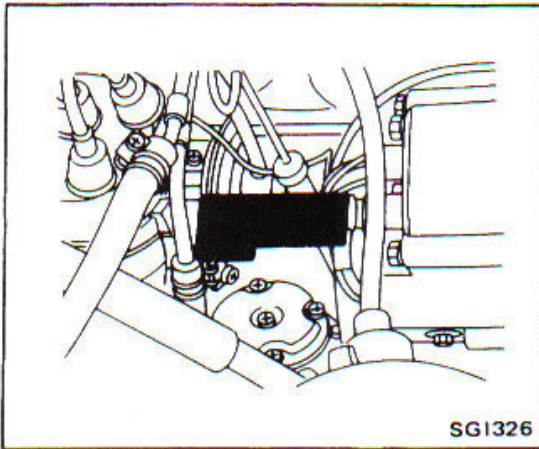

The engine serial number is stamped on the right side of cylinder block.

H20- H25-Sxxxxx x

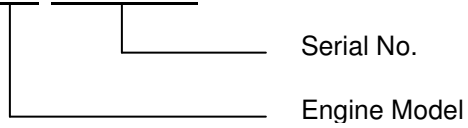

Service Data and Specifications

INSPECTION AND ADJUSTMENT

Item	Engine model	H20-H25
Valve clearance (Hot) mm (in) Intake Exhaust		0.38 (0.015)
Fan belt deflection mm (in) Applied pushing force N (kg lb)		1 to 13 (0.040 to 0.51) 98 (10, 22)
Engine oil capacity Lit. (US qt, Imp qt) With oil filter Without oil filter		3.8 (4.0, 3.34) 3.5 (3.70, 3.07)
Engine compression pressure kPa (bar, k/cm ² , psi)/rpm Standard Minimum		1,275 (12.75, 13.0, 185)/300 1,079 (10.79, 11.0, 156)/300
Spark plug Type Gap mm (in)		BP4WES, BPR4ES 0.8 - 0.9 (0.031 - 0.035)
Distributor Air gap mm (in)		0.35 - 0.45 (0.014 - 0.018)
High tension cable resistance		Less than 30,000
Ignition timing idle speed B.T.D.C. degree/rpm		4°/650

TIGHTENING TORQUE

UNIT	N•m	kg-m	ft-lb
Cylinder head bolt	74 – 83	7.5 – 8.5	54 – 61
Rocker cover nuts	1.8 – 2.7	0.18 – 0.28	1.3 – 2.0
Rocker shaft	49 – 59	5.0 – 6.0	36 – 43
Connecting rod cap bolts H20-H25	38 – 44	3.9 – 4.5	28 – 33
Main bearing cap bolt	83 – 93	8.5 – 9.5	61 – 69
Flywheel housing fixing bolts	43 – 58	4.4 – 5.9	32 – 43
Flywheel fixing bolts or driving plate	132 – 142	13.5 – 14.5	98 – 105
Camshaft sprocket bolt	29 – 39	3.0 – 4.0	22 – 29
Oil pan bolts	6.4 – 7.5	0.65 – 0.76	4.7 – 5.5
Oil pan drain plug	20 – 39	2.0 – 4.0	14 – 29
Manifold nuts	16 – 19	1.6 – 1.9	12 – 14
Crank pulley bolt	142 – 152	14.5 – 15.5	105 – 112
Engine front cover bolts	16 – 19	1.6 – 1.9	12 – 14
Alternator bolts	44 – 59	4.5 – 6.0	33 – 43