

**OPERATION AND
MAINTENANCE
INSTRUCTIONS**

**CATERPILLAR
D398 AND D379
MARINE ENGINES**

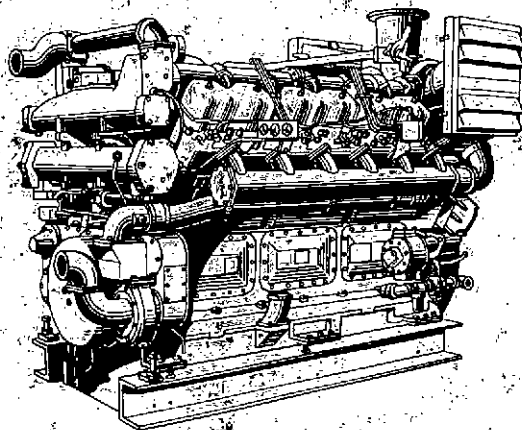

SERIAL NUMBERS

69B1-UP D379

67B1-UP D398

Avoid Accidents

Most accidents, whether they occur in the air, in industry, on the farm, at home, on the highways, or at sea, are caused by someone's failure to follow simple and fundamental safety rules or precautions. For this reason most accidents can be prevented by recognizing the real cause and doing something about it before the accident occurs.

Regardless of the care used in the design and construction of any type of equipment, there are many conditions that cannot be completely safeguarded against without interfering with reasonable accessibility and efficient operation.

A careful operator is the best insurance against an accident.

The complete observance of one simple rule would prevent many thousands of serious injuries each year. That rule is: "Never attempt to clean, oil or adjust a machine while it is in motion."

Inspections service tabs (1) and (2) are attached to the Engine Warning and Information plate of each engine. The serviceman performing the inspection will remove a tab after each inspection. In addition, the serviceman will complete a report of his inspection which is to be signed by the OEM machine owner or his representative. The Inspection Service Report is then sent to Caterpillar to become a part of the engine history record.

ENGINE WARNING AND INFORMATION PLATE

This plate is mounted on the engine. A similar plate should be mounted so as to be in the full view of the operator.

- 1-Inspection No. 1 tab.
- 2-Inspection No. 2 tab.

MOBIL	NO. OF CYL.	ROSE	STEEL
ENGINE SERIAL NO.			
DATE DELIVERED	INSPECTION NO. 1		
DEALER	INSPECTION NO. 2		
500 HOURS OF MILE			
HIGH MILE ENGINE R.P.M.			
FULL LOAD ENGINE R.P.M.			
VALVE SETTINGS			
I.P. SETTING AT SEA LEVEL			
INJECTION TIMING			
VALVE SETTING AT I.C.			
BILL OF MATERIAL OR ESG NO.			
WARNING: TURBOCHARGED ENGINES ONLY - ENGINE HAS BEEN CORRECTLY SET TO OPERATE AT ALTITUDE LIMIT SHOWN INSPECTION NO. 2			
<small> DOWNDRAUGHT AND TURBOCHARGED AIR INTAKE - DO NOT CHANGE VALVE SETTING, INJECTION TIMING OR ENGINE SPEED WITHOUT PER- MITS. OPERATIONS: THE MAIN INTAKE MUST BE CHANGING FROM CATERPILLAR DESIGN MODEL OPERATION AT A SINGLE ALTITUDE. THIS TO OPERATION AND REINSTALLMENT INSTALLMENT THE ONLY DESIGNATION. </small>			

Table of Contents

	Page
INSTALLATION INSTRUCTIONS	8-12
LUBRICATION INSTRUCTIONS	13-23
OPERATION INSTRUCTIONS	25-44
MAINTENANCE INSTRUCTIONS	45-63
ATTACHMENT INSTRUCTIONS	65-88
INDEX	89-90
CAPACITIES	Inside Back Cover
LOCATION OF SERIAL NUMBER	Inside Back Cover

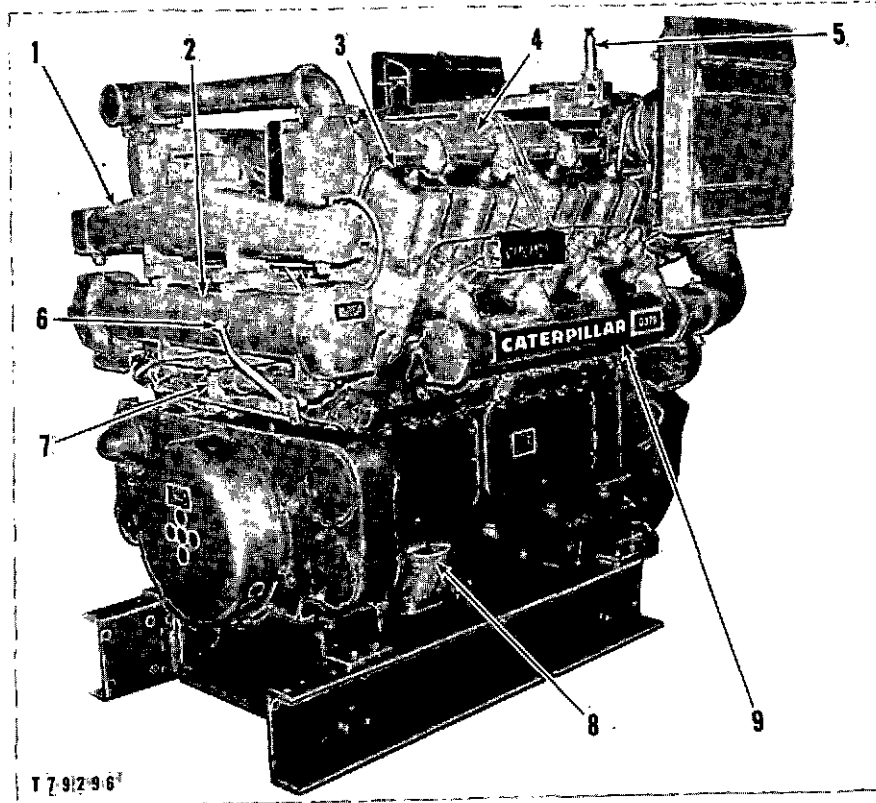

T 7-912-9-67

D379 MARINE ENGINE - LEFT FRONT VIEW

1-Diesel fuel filter housing. 2-Diesel engine crankcase lubricating oil filter housing. 3-Cylinder head valve cover. 4-Water cooled exhaust manifold. 5-Governor control lever. 6-Diesel fuel priming pump. 7-Service meter. 8-Diesel engine crankcase lubricating oil filler cap. 9-Air inlet manifold.

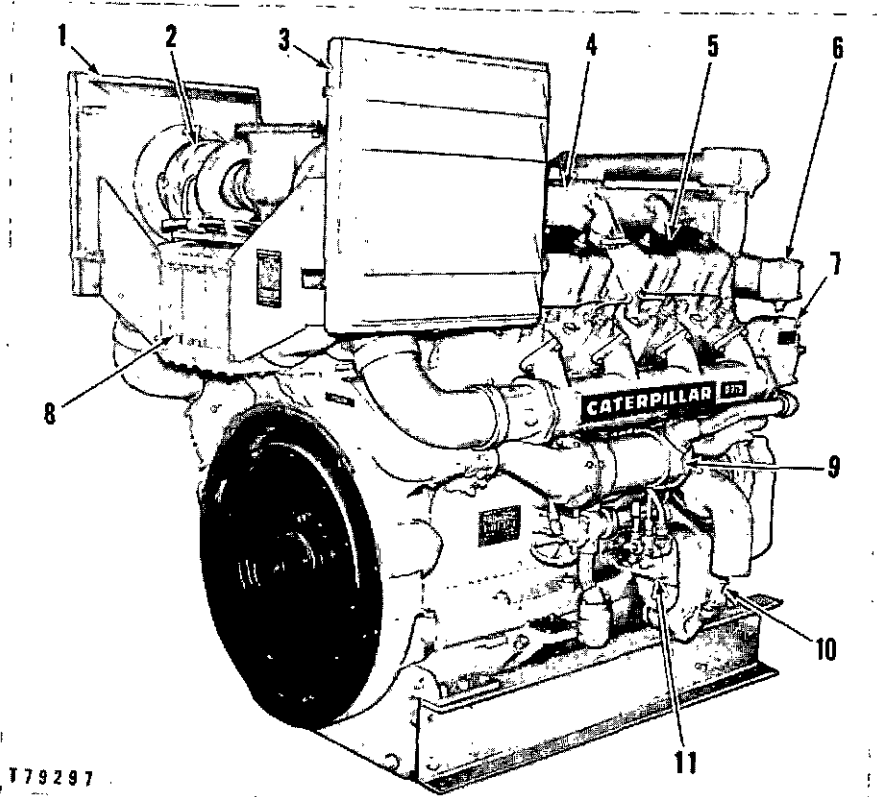

179297

D379 MARINE ENGINE - RIGHT REAR VIEW

1-Air cleaner. 2-Turbocharger. 3-Air cleaner. 4-Water cooled exhaust manifold.
 5-Cylinder head valve cover. 6-Diesel fuel filter housing. 7-Diesel engine crankcase lubricating oil filter housing. 8-Aftercooler. 9-Diesel engine crankcase lubricating oil cooler. 10-Diesel engine crankcase lubricating oil pump.
 11-Fuel transfer pump.

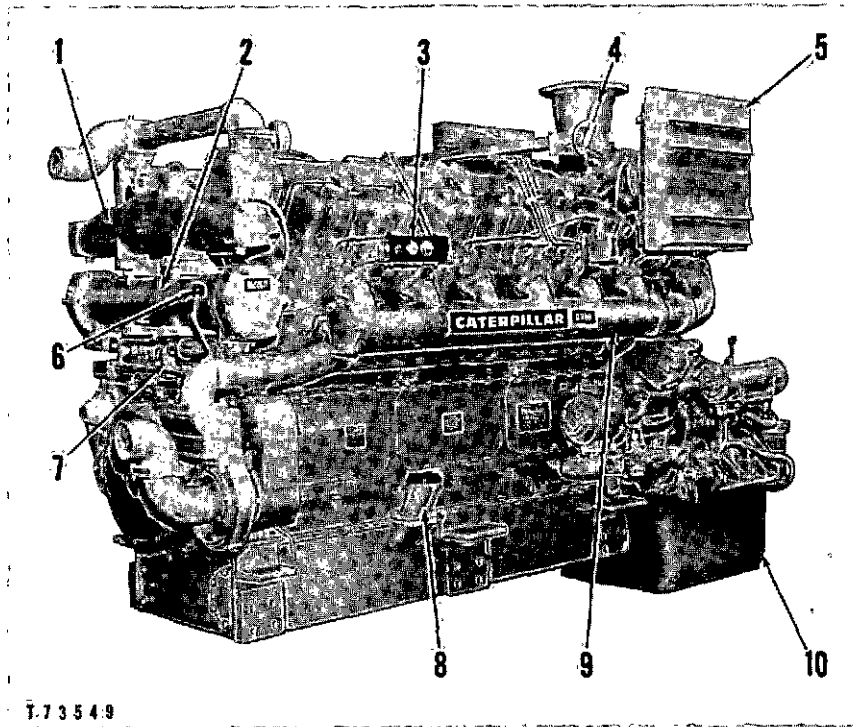

D398 MARINE ENGINE — LEFT FRONT VIEW

1—Diesel fuel filter. 2—Crankcase lubricating oil filter. 3—Instrument panel. 4—Governor control. 5—Air cleaner. 6—Diesel fuel priming pump. 7—Service meter. 8—Crankcase lubricating oil filler tube. 9—Air inlet manifold. 10—Marine gear.

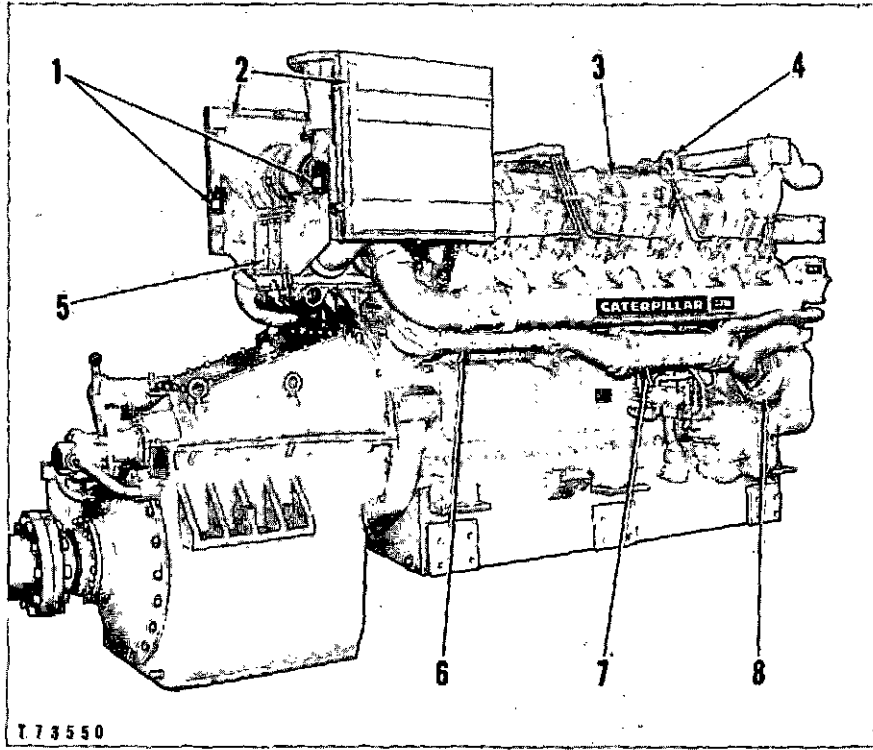

D398 MARINE ENGINE — RIGHT REAR VIEW

- 1—Air cleaner service indicators.
- 2—Air cleaners.
- 3—Water-cooled exhaust manifold.
- 4—Diesel engine front lifting eyes.
- 5—Aftercooler.
- 6—Diesel engine water manifold.
- 7—Diesel engine crankcase lubricating oil cooler.
- 8—Diesel engine fresh water pump.

Installation Instructions

There are a number of factors that warrant careful consideration when installing an engine. Careful thought and planning on installation details can pay dividends in increased engine life and successful operation. Attention should be given to installation details that will make operation and maintenance easy, such as ample clearance around bulkheads and surrounding machinery. Accessibility for adjustment and maintenance should be assured and proper provision made for pumping out crank-case oil. The following comments will touch briefly on some of the more important factors, but for more specific recommendations, it is suggested that your Caterpillar dealer be consulted.

COOLING

Probably the most important consideration is that of making sure the engine will cool properly

Install a 4 inch (101.6 mm.) or larger sea water intake suction pipe at a sufficient level below the water line so the opening will not be uncovered by a heavy sea. Care should also be taken not to locate this opening too close to the bottom, as sand and dirt will be drawn into the line in shallow water. A duplex type of basket strainer with 1/16 inch (1.57 mm.) openings **must** be installed in the suction line to keep foreign accumulations from reaching the raw water pump and damaging the impeller. Also, install all drain plugs furnished.

Connect a 2 1/2 inch (63.5 mm.) or larger sea water overflow pipe to the outlet side of the heat exchanger. This pipe can discharge directly overboard and a portion of the water may be diverted through the exhaust pipe for cooling with a wet exhaust system. In this latter instance the location and design of the exhaust pipe must be such that no water can possibly get back into the engine by flooding through the individual cylinder exhaust valves due to excessive rolling and pitching of the vessel when operating on a heavy sea.

DIESEL FUEL TANKS

In many cases the lack of space in small boats makes it advisable to install several small fuel tanks in convenient locations rather than one large one. When this occurs it is suggested that the fuel lines from all the tanks be connected to a combined fuel manifold and sediment condensation trap as illustrated. Since this forms a common connection for all tanks, it simplifies the supplying of fuel to the engine.

The baffle plates reduce fuel agitation thus trapping sediment and condensation which can be drawn off when necessary through the drain. Fuel by-passed at the fuel filter housing is returned to the trap rather than the individual tanks, thereby eliminating the danger of overflow.

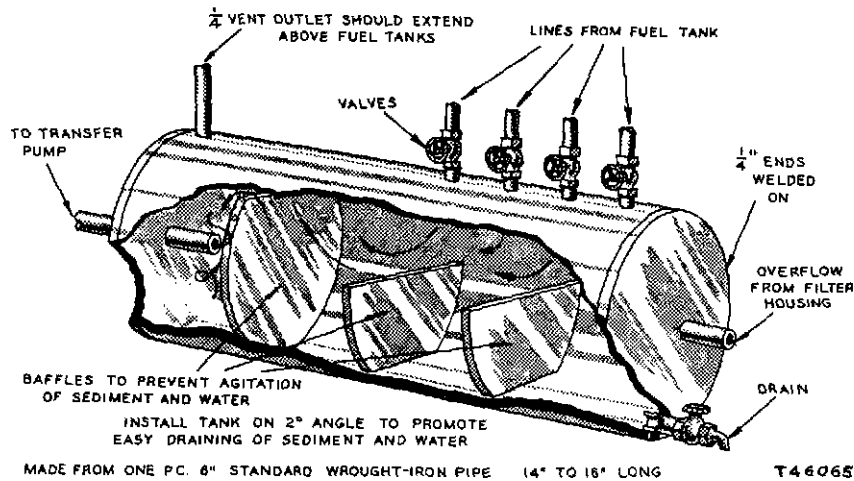

SEDIMENT TRAP

If any of the tanks are so mounted that there is a suction lift required, then it will be essential that all of the other tank connections be tightly closed by the valves shown, or the suction lift of the pump will be broken by air leaks from another tank.

FUEL LINES

Flexible fuel lines are recommended on all permanent installations. The transfer pump will lift fuel the height of 12 feet (3.7 meters) through no more than 50 feet (15.24 meters) of fuel line. Connect a return line from the fuel transfer pump to the top of the diesel tank or sediment trap if so equipped.

It is essential that there be no air leaks in the suction system. Even a small leak will destroy the suction lift of the transfer pump.

EXHAUST LINES

Flexible connections should be used to prevent transmission of engine vibrations to exhaust piping. Flexible metal tubing is generally recommended for the exhaust connections at the engine. The exhaust outlet should be protected from the weather so that rain and snow cannot enter the line and get into the engine. The exhaust lines should be as short as possible. Long exhaust lines or lines with several bends should be of increased diameter so as not to create excessive back pressure. The back pressure for a new installation should not exceed 15 inches (38.1 cm.) of water at full load and rated speed, when measured with a manometer at the exhaust connection of the engine. Exhaust from the starting engine, if diesel engine is so equipped, should be carried in a separate line and not connected into the diesel exhaust line.

ENGINE MOUNTING AND SHAFT ALIGNMENT

Coupling Alignment: Extreme care should be exercised in the alignment of the engine and propeller shaft. The alignment of the marine gear coupling and the propeller shaft coupling should be checked after the vessel has been launched as hull distortion sometimes takes place after the vessel is in the water. Uncouple the propeller shaft from the marine gear and check the propeller shaft alignment. There are two particular points of alignment that must be considered. These two points are commonly referred to as angular or face alignment and bore alignment. There should be less than .0005 inch (.0126 mm.) per inch of diameter face misalignment and .005 inch (.126 mm.) bore misalignment. If the variation is greater than this amount, alignment can be restored by adjusting the leveling capscrews. Hold-down bolts or lag screws should be of such diameter as to make a tight fit in the hole of the support bracket. This is necessary to prevent movement of the engine on its supports. At frequent intervals, check this alignment especially in freight boats. Failure to keep the engine and propeller shaft in alignment would cause damage to the various marine gear parts and propeller shaft bearing.

Marine Gear Installation: When a marine gear is not installed at the factory or is removed and reinstalled, care should be taken to insure correct alignment between the marine gear and the engine. Improper alignment will result in undue wear or damage to the marine gear mechanism. It is recommended you consult your Caterpillar dealer for specific information on installing a marine gear on the diesel engine.

Frequently the design of a vessel necessitates the engine being installed with a slight slope from fore to aft. This angle of inclination should never exceed 10°. If the angle of inclination is between 10° and 17°, consult your Caterpillar dealer.

DIESEL ENGINE CRANKCASE OIL LEVEL GAUGE MARKING

The engine has had most of the oil drained from the crankcase before shipment from the factory. Before installing the engine prepare for marking the oil level gauge by leveling the engine, removing the crankcase drain plug and draining any oil accumulation. Install the drain plug.

When the engine has been installed in its final location, fill the crankcase with the quantity of oil recommended on the capacity chart on the inside back cover of the Operation and Maintenance Instructions. Then run the engine for a short period of time to distribute oil to all parts of the engine. The oil level should then be checked with the engine running. The oil level indicated by the top of the oil on the gauge should be permanently marked on the gauge for the full "running level." This will vary depending upon the angle at which the engine is mounted in the vessel. It is recommended that the low mark on the gauge be left in its present position.

MARINE GEAR CONTROLS

Remote Controls: The marine gear control should be installed with the neutral position plainly marked in the pilot house to avoid unnecessary slipping of the clutches during the idling periods. The linkages should operate freely without excessive looseness to insure complete engagement of the clutch. Brackets, levers and rods should be of sufficient strength to prevent bending, buckling or breaking. Plenty of travel room should be allowed rod ends and levers to assure complete engagement of the clutch.

To prolong the life of the marine gear clutch, provisions should be made for the time requirement necessary for proper clutch engagement. If the controls are of the single lever type, adjustment must be made so that the engine remains at low idle speed until the marine gear clutch is fully engaged.

CRANKCASE BREATHER FUMES DISPOSAL

The crankcase breather fumes disposal tube should be directed or extended to a location that will prevent an oily film from being deposited in the engine room. If oily fumes were allowed to be drawn into the engine dry type air cleaner, frequent air cleaner filter element servicing will result. A 1.5 inch (3.81 cm.) tube not to exceed 25 feet (7.6 meters) in length connected to the crankcase breather fumes disposal tube and piped to the atmosphere is recommended. Greater lengths will cause excessive crankcase back pressure. Also in order to keep crankcase pressure low, the number of bends should be kept to a minimum. Loops and low spots in the tube should be avoided or improper crankcase breathing will result from trapped condensate in the loops and low spots.

CORRECT AIR CLEANING IS NECESSARY

Caterpillar air cleaners are designed to remove all harmful elements from the air entering the engine. Dusty atmospheric conditions will cause frequent servicing and short element life. Precleaners are available to provide reasonable service periods and element life. Air inlet extension can be utilized to provide cleaner and cooler air to the air cleaner. Your Caterpillar dealer has additional information.

ELECTRICAL EQUIPMENT

Generator and Alternator Regulator: When the engine is equipped with a 32 volt charging system it is advisable to mount the generator regulator at same location other than on the engine. This will reduce to a minimum, any damage or irregular operation of the generator regulator which might be caused by vibration or oil and water from the engine.

The transistor alternator regulator is an assembly of transistors, resistors, condensers and diodes; and contains no moving parts. These com-

ponents could be damaged if exposed to temperatures above 140° F. in still air or 170° F. in moving air. It is advisable to mount the alternator regulator away from the engine.

Battery Installation: Storage batteries should not be placed on the floor. A rack high enough to place them in a comfortable position for maintenance should be built of wood or metal and heavily painted with an acid-resistant paint. The batteries should be located where heat from the engine or other source will not reach them and cause their temperature to become excessive. Storage battery ratings are based on a battery temperature of 77° F. If the area where the batteries are installed can be kept near or below this temperature, it will help in obtaining good engine cranking and good service life. Batteries should not be stored in a discharged state.

Lubrication Instructions

Marine Gear information is covered in the Operation and Maintenance Instruction Book for the Marine Gear

SERVICE METER

The Service Meter is located at the front of the engine below the engine crankcase lubricating oil filter housing. It is geared to the engine, and when the crankshaft turns as many revolutions as are made in an hour at average operating speed on an average job application, the dial advances one number. There are some applications that will result in either a lower or higher than normal average engine speed. Under this condition, the advance in the Service Meter reading will differ from the number of clock hours of operation.

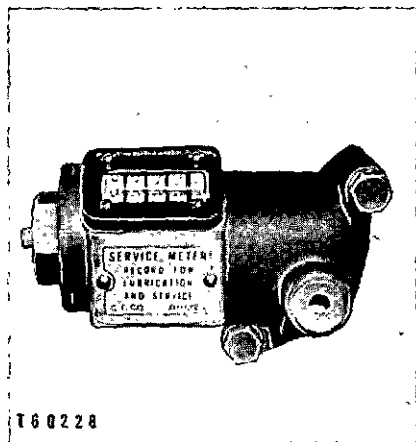

SERVICE METER

The purpose of the Service Meter is to indicate when to perform the recommended maintenance and lubrication operations. The established intervals in the lubrication chart and maintenance instructions are given in service hours, so daily readings will tell when to service the engine. Rely on the Service Meter and not on the clock to measure service intervals.

GENERAL LUBRICATION INFORMATION

Careful attention to the following information on lubricants and their proper selection will add much to performance, economy and long life of your engine. The lubrication chart specifies the lubricants to be used, the points to be serviced and the hourly intervals of servicing according to service hours.

Lubricate all miscellaneous points, not equipped with fittings, with crankcase lubricating oil every 50 service hours.

It is extremely important in handling the oil to keep it clean. Every precaution should be taken to use only clean filler cans and to be sure that all dirt is removed from the filler cap before it is taken off for filling. The operator should take every precaution to prevent dirt from getting into any system to extend the life of the engine.

Naturally, any precautions taken during cold weather to house the engine, cover it with a tarpaulin, or warm it before starting, will cause more rapid oil distribution and contribute to quicker starting. The engine should always be allowed to idle at approximately half engine speed for several minutes after starting to assure adequate lubrication before operating at normal load.

DESCRIPTION OF LUBRICANTS

The lubricants recommended for use in this engine can be identified by the sub-headings that follow: The proper selection of one of these types of crankcase lubricating oils, and SAE grade of oils can be made from the information in the topic, TYPE OF LUBRICANTS AND SAE GRADES TO USE.

Crankcase Lubricating Oils

Superior Lubricants (Series 3): These are additive-type oils that have been identified as meeting a rigid, high quality standard and certified for use in all Caterpillar Diesel Engines. See your Caterpillar dealer for brand names of products conforming to this specification.

MIL-L-2104A or MIL-L-2104B Specification Oils: These oils are additive-type but are milder than Superior Lubricants (Series 3) Oils. They can be used as specified for various compartments satisfactorily. Your oil supplier is familiar with those oils.

Lubricating Grease

Multipurpose-Type Grease: This lubricant is a mixture of mineral oil and metallic or nonmetallic thickeners.

Use NLGI No. 2 Grade for most temperatures. For extremely low temperatures, use NLGI No. 0 or No. 1 Grade.

This grease can be applied to all points, such as chassis, wheel bearing, universal joint and other miscellaneous applications.

Water Pump Grease: This lubricant should be insoluble in water to prevent an emulsification of the lubricant. An emulsification of the lubricant could allow water in the bilge to leak by the seal into the marine gear housing.

Type of Lubricants and SAE Grades to Use

The grade of oil is classified in terms of viscosity (fluidity or flow ability) and is identified with numbers called SAE numbers. Oil with lower SAE numbers are more fluid and flow more readily than do those with the higher numbers. Crankcase lubricating oils are recommended for use

in gear compartments because of their superior oxidation and corrosion inhibitors.

SAE 10W oil should be fluid enough for easy cranking at starting atmospheric temperatures down to at least -10°F . When starting in temperatures below -10°F ., the diesel engine crankcase lubricating oil should be warmed to provide fluidity in cold weather. **Do not dilute** the diesel engine crankcase lubricating oil.

The oil specification chart will aid in the proper oil grade selection for the various compartments. The proper SAE grade of oil to select is determined by the atmospheric temperature at which the machine is started. However, during **operation** SAE 10W oil can be used successfully in the diesel engine crankcase when atmospheric temperatures are as high as 70°F .

OIL SPECIFICATION CHART

Compartment	SAE GRADE OF OIL TO USE AT STARTING ATMOSPHERIC TEMPERATURE			
	Above $+32^{\circ}\text{F}$.	$+32^{\circ}\text{F}$. to $+10^{\circ}\text{F}$.	$+10^{\circ}\text{F}$. to -10°F .	-10°F . and Lower
Diesel Engine Crankcase	Superior Lubricants (Series 3) SAE 30* SAE 10W* SAE 10W Heat SAE 10W			
Starting Engine Crankcase	Superior Lubricants (Series 3) or MIL-L-2104A or B SAE 10W SAE 10W SAE 10W **Dilute SAE 10W			
Starting Engine Transmission	Superior Lubricants (Series 3) SAE 30 SAE 10W SAE 10W **Dilute SAE 10W			
Front Power Take-off Gear Case	Superior Lubricants (Series 3) SAE 30 SAE 30 SAE 10W SAE 10W			

*In seasons or locations where starting atmospheric temperatures are below 32°F ., SAE 10W oil should be used to insure free circulation, even though daytime operating atmospheric temperatures may rise as high as 70°F .

**In lower temperatures it may be necessary to dilute oil with kerosene so it will be fluid enough to insure free circulation. This should be done before stopping, then operate the engine for a few minutes to mix the kerosene and oil. Evaporation in the engine crankcase under steady operation may make it necessary to again add kerosene to maintain proper fluidity.

Crankcase Lubricating Oil Change Periods

The crankcase lubricating oil change periods for these engines have been carefully established for the purpose of protecting the service life of the engine as economically as possible.

Oil change periods for engines similar in size are sometimes established by chemical analysis of a sample of the lubricating oil. Due to the several other factors that must be considered in determining satisfactory oil change periods, chemical analysis alone is not sufficient for this purpose.

Change the oil and filter elements after the first 10 service hours of operation of a reconditioned engine.

DIESEL ENGINE CRANKCASE LUBRICATING OIL CHANGE PERIOD CHART
Use Only Superior Lubricants (Series 3)

FUEL SULPHUR CONTENT	OIL CHANGE PERIOD*	FILTER ELEMENT CHANGE PERIOD*
0.4% or less	750 Service Hrs.	375 Service Hrs.
0.4% to 1.0%	375 Service Hrs.**	375 Service Hrs.

*Regardless of time operated, the crankcase oil and filter elements should be changed at least every six months.

**Reduce crankcase oil change periods one half when sulphur content is greater than 1.0%.

T81506

LUBRICATION CHART
CATERPILLAR
D398 AND D379
MARINE ENGINES

The illustration on the following page indicates the approximate locations of all points requiring servicing.

The chart is keyed to this illustration and to the related detailed topics and illustrations on the succeeding pages. The service intervals are measured in service meter hours.

CO Crankcase Lubricating Oil

1

DIESEL ENGINE CRANKCASE LUBRICATING OIL FILTER

Remove drain plugs (7) in each end cover and drain plugs (8) from the lubricating oil filter housing. Remove end cover (9) on the oil inlet (right) end of the housing. Remove the four used lubricating oil filter elements and discard them. It may be necessary to also remove the end cover from the filtered oil outlet (left) end of the housing so that the used filter elements may be pushed out of the inlet end of the housing. When cleaning the inside of the filter housing always clean from the filtered oil outlet (left) end toward the oil inlet (right) end of the housing so that the unfiltered oil will not enter the filtered oil passage to the engine. Install new Caterpillar elements (10), the filter housing end cover or both covers if both have been removed, and the drain plugs. See the "Diesel Engine Crankcase Lubricating Oil Change Period Chart."

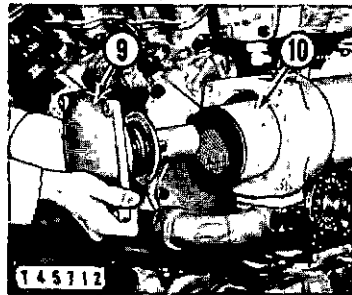
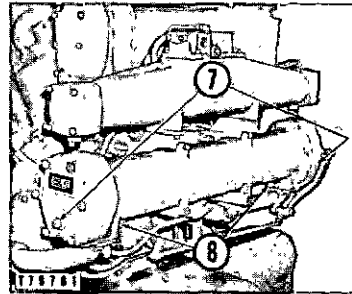

1

DIESEL ENGINE CRANKCASE

Use Superior Lubricants (Series 3) only

After draining the crankcase lubricating oil, refill at (11). Start and run the diesel engine for two minutes, then while the engine is running, check the oil level on the gauge. It will be necessary to add oil to bring the oil level up to the "full" mark on the gauge. If the diesel engine is equipped with a remotely mounted crankcase lubricating oil auxiliary tank, the engine will have to run considerably longer and a greater amount of oil must be added to the diesel engine crankcase to bring the oil level up to the "full" mark on the gauge. Do not overfill. See the topic, "Type of Lubricants and SAE Grades to Use."

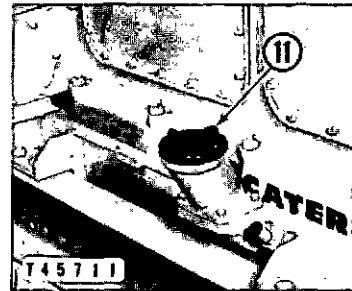

1

DIESEL ENGINE CRANKCASE BREATHER

At each crankcase lubricating oil change period, remove crankcase breather (12) from the cylinder block and wash the element, inside the breather, with clean kerosene or diesel fuel. If gasket is damaged, it must be replaced. Reinstall the breather.

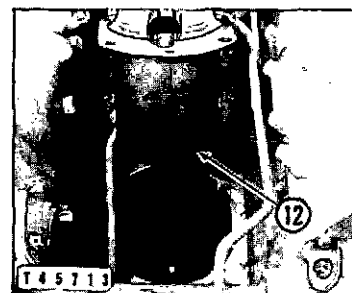

CO Crankcase Lubricating Oil

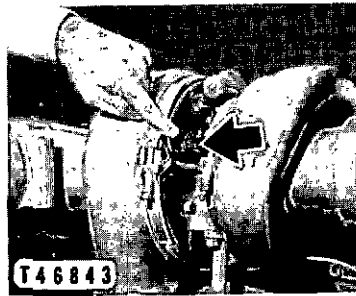

1

TURBOCHARGER BREATHER

(Engines Before 69B118 and 67B105)

At each oil change period, remove the element from the turbocharger breather and wash in clean kerosene. Install the element.

BR Ball and Roller Bearing Lubricant

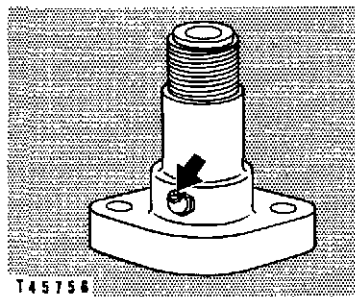

2

TACHOMETER DRIVE

Lubricate with one stroke from a grease gun every 1000 service hours.

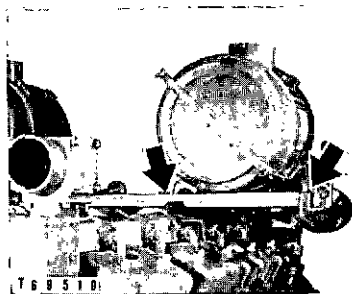

GOVERNOR CONTROL SHAFT

(Engines Before 69B97 and 67B96)

Lubricate with one stroke from a grease gun every 1000 service hours.

Lubrication of Attachments

The following list of identifying letters, names of attachments requiring lubrication and types of lubricant required will help in lubrication of attachments.

SEE DETAILED INSTRUCTIONS UNDER
EACH CORRESPONDING TOPIC NUMBER HEADING

Point and Identification	Lubri- cant	SERVICE HOURS					
		10	50	125	250	1000	2000
A STARTING ENGINE CRANKCASE	CO	X			†C		
B STARTING ENGINE TRANSMISSION	CO				X	CW	
C STARTING ENGINE ELECTRIC STARTER	CO	SEE DETAILED INFORMATION					
D AIR STARTING MOTOR OILER	CO	X					
E AIR STARTING MOTOR GEAR DRIVE	BR	SEE DETAILED INFORMATION					
F DIESEL ENGINE ELECTRIC STARTER	CO	SEE DETAILED INFORMATION					
G AIR STARTING MOTOR DRIVE END BEARING	CO						L
H FRONT POWER TAKE-OFF GEAR CASE	CO		X				C
I FRONT POWER TAKE-OFF THROW-OUT COLLAR	BR	L					
J FRONT POWER TAKE-OFF PILOT BEARING	BR			L			
K CHARGING GENERATOR	BR	SEE DETAILED INFORMATION					
L CHARGING ALTERNATOR	BR	SEE DETAILED INFORMATION					
M AIR STARTING MOTOR PLAIN END	BR	SEE DETAILED INFORMATION					
N ENCLOSED CLUTCH							
SHIFT COLLAR	BR	L					
CLUTCH SHAFT BEARING	BR			L			
CLUTCH PILOT BEARING	BR			L			
O ENCLOSED CLUTCH SHIFT COLLAR SHAFT	BR		L				

Key to Lubricants

CO CRANKCASE LUBRICATING OIL

BR BALL AND ROLLER BEARING LUBRICANT

Key to Symbols

X — CHECK, ADD OIL IF NECESSARY
L — LUBRICATE

C — CHANGE CW — CHANGE AND WASH
† — DEPENDING ON DUST CONDITIONS

CO Crankcase Lubricating Oil

A

STARTING ENGINE CRANKCASE

Check the oil level every 10 service hours with starting engine stopped. Oil should be up to "full" mark on gauge (2).

Every 125 to 250 service hours, depending on dust conditions, drain the crankcase at (3). When draining, the engine must be level so the oil in the starting engine clutch compartment will drain. Wash the crankcase breather at each oil change period. Refill the crankcase at (1). Fill slightly above the "full" mark on the gauge. Start and run the starting engine at least one minute to equalize the oil level in the crankcase and clutch compartment. Stop the engine and check the oil level. The oil level should be up to the "full" mark on the gauge. See the topic, "Type of Lubricants and SAE Grades to Use."

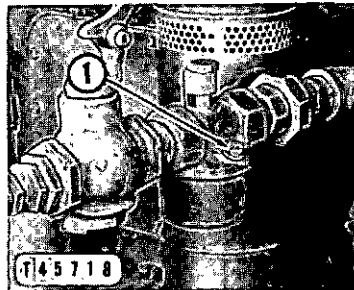
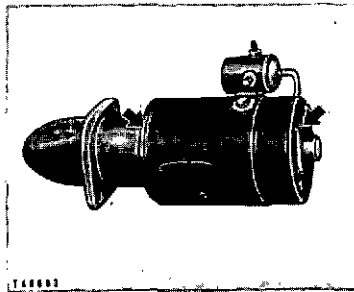
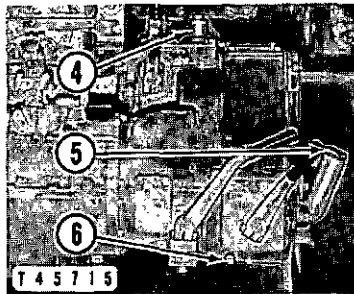
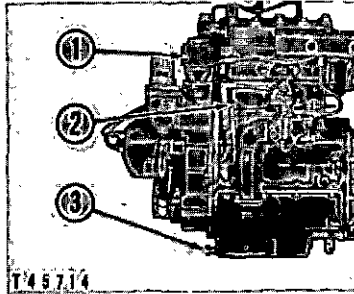

B

STARTING ENGINE TRANSMISSION

Every 250 service hours check the oil level on the gauge (5) in the filler opening. Fill to "full" mark on gauge. Remove breather (4), disassemble and wash.

Every 1000 service hours, remove drain plug (6). Wash and refill the transmission. See the topic, "Washing Gear Compartments."

C

STARTING ENGINE ELECTRIC STARTER

The electric starting motor for the starting engine is equipped with bearings of a type that make lubrication necessary only when the starter is disassembled for cleaning or servicing. Two or three drops of oil for each bearing is sufficient.

D

AIR STARTING MOTOR OILER

Every 10 service hours check oil level in oiler by removing plug (1). Keep the bowl approximately one-half to three-fourths full. Do not overfill.

CO Crankcase Lubricating Oil

F

DIESEL ENGINE ELECTRIC STARTER

Electric starting motor for the diesel engine is equipped with bearings of a type that makes lubrication necessary only when the starter is disassembled for cleaning or servicing.

To lubricate, remove the starting motor and the plugs. Saturate the wicks with crankcase lubricating oil. Install the plugs and starting motor.

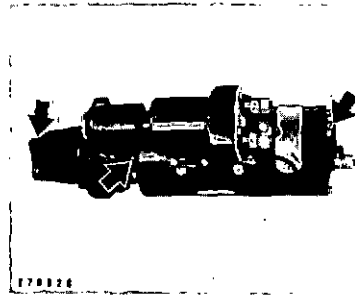

G

AIR STARTING MOTOR DRIVE END BEARING

The air starting motor for the diesel engine has a bearing in the drive end that requires lubrication every 2000 service hours, or whenever the motor is removed for any reason.

To lubricate remove the starting motor and the plug (1). Saturate the wick with crankcase lubricating oil. Reinstall the plug and starting motor.

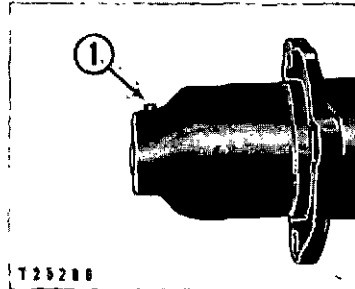

H

FRONT POWER TAKE-OFF GEAR CASE

(3:1 anti-engine rotation reduction)

Every 50 service hours check oil level by removing plug (2). Oil should be to the level of the plug opening. Remove breather (1) to add or refill with oil.

Every 2000 service hours drain by removing plug (3). Clean and install the plug. Remove breather (1) and wash in clean kerosene or diesel fuel. Refill the case to the level of plug (2).

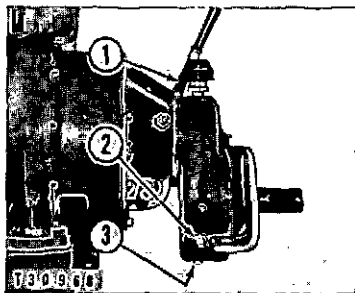

BR Ball and Roller Bearing Lubricant

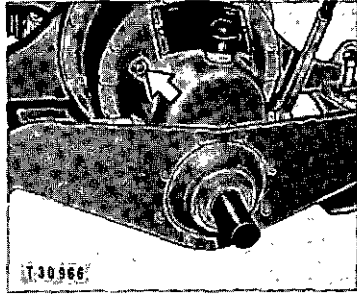

I

FRONT POWER TAKE-OFF THROW-OUT COLLAR

(3:1 anti-engine rotation reduction)

Lubricate clutch throwout collar every 10 service hours before starting the engine.

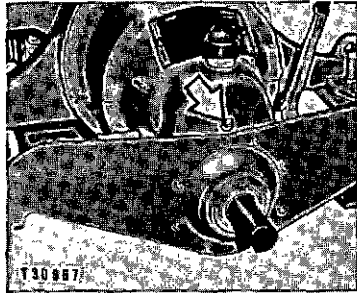

J

FRONT POWER TAKE-OFF PILOT BEARING

(3:1 anti-engine rotation reduction)

Lubricate clutch pilot bearing every 125 service hours of operation.

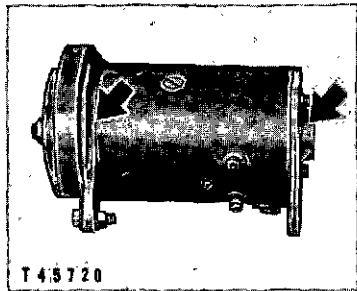

K

CHARGING GENERATOR

12 volt generators have bearings packed with Ball and Roller Bearing Lubricant making lubrication necessary only when the generator is disassembled for cleaning or servicing.

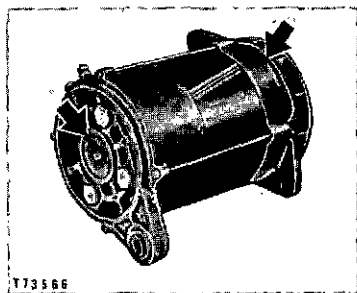

L

CHARGING ALTERNATOR

Under normal operating conditions the alternator bearings will not require lubrication between reconditioning periods. At the time of reconditioning, half fill the reservoir in each end frame with a special lubrication, available from your Caterpillar dealer.

BR Ball and Roller Bearing Lubricant

E and M

AIR STARTING MOTOR GEAR DRIVE AND PLAIN END

Air starting motor gear drive and plain end bearing compartments are packed at the time of assembly and require no periodic lubrication. If the motor is disassembled for any reason, No. 1 BALL AND ROLLER BEARING LUBRICANT should be used to fill the compartments.

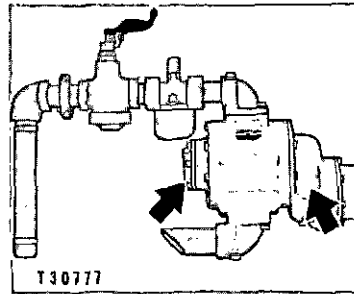

N

ENCLOSED CLUTCH

Lubricate shift collar through fitting (1) every 10 service hours.

Lubricate clutch shaft bearing through fitting (2) every 125 service hours.

Lubricate clutch pilot bearing through fitting at (3) with one or two strokes from the grease gun every 125 service hours.

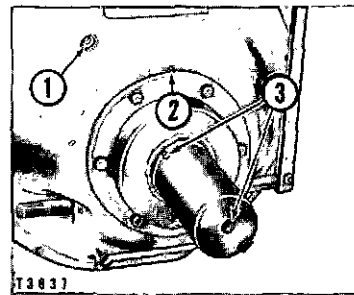

O

ENCLOSED CLUTCH SHIFT COLLAR SHAFT

Lubricate shift collar shaft bearings at (1) every 50 service hours.

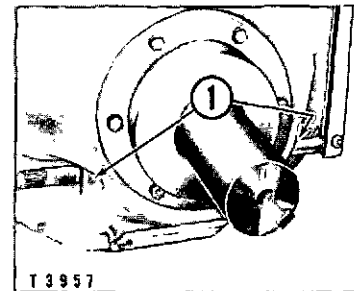

Operation Instructions

Marine Gear information is covered in the Operation and Maintenance Instructions Book for the Marine Gear

WARNING

Remove covering from air cleaner element before starting engine.

PREPARING THE ENGINE FOR USE

New Engine Initial Service: The first duty of anyone charged with the care and operation of an engine is to give it a detailed inspection, including a check to see that all shipping straps, brackets, bolts and skids are removed, and to lubricate all parts as directed in the LUBRICATION INSTRUCTIONS section of this book.

Fill the diesel fuel tank, taking care no dirt, water, or other foreign substances are admitted with the fuel. Give particular attention to the details of fuel handling as outlined under the topic, CARE OF THE FUEL SUPPLY. Fill the starting engine fuel tank with gasoline when equipped with gasoline starting system.

Fill the cooling system with clean soft water and rust inhibitor, or with the correct anti-freeze solution if temperatures below freezing are likely to be encountered. See the topic, COOLING SYSTEM.

Prime the raw water pump before starting the engine. See the topic, RAW WATER COOLING SYSTEM.

New Engine Recheck: After the first 100 to 125 service hours of operation, tighten the diesel engine air inlet and exhaust manifolds, and the turbocharger mounting bolts. When equipped with a gasoline starting engine, tighten the starting engine exhaust connections and carburetor elbow.

New Operator's Responsibility: The operator who is given the responsibility of care and operation of an engine already in service, should first, check it for necessary lubrication, fuel supply and coolant in the cooling system.

Second, make any necessary adjustments to obtain satisfactory performance from the engine. If the engine has been moved to a new altitude, see the topic, ALTITUDE OPERATION.

STARTING THE ENGINE

Before Starting: Be sure to check the oil level in the diesel engine crankcase to make sure the oil level is above the "add oil" mark on the gauge.

When the engine is equipped with a safety shut-off control or safety alarm switches, see the topics, SAFETY SHUT-OFF CONTROL and SAFETY ALARM SWITCHES before attempting to start the engine.

Place the marine gear control lever in neutral position and disengage or remove all possible load from the engine. Then start the engine as described in whichever one of the following topics applies, GASOLINE STARTING ENGINE, ELECTRIC STARTING MOTOR, or AIR STARTING MOTOR. If the diesel engine is equipped with hydraulic starting, follow the topic, POSITION THE CONTROLS FOR STARTING in the AIR STARTING topic and continue to the topic, STARTING THE DIESEL ENGINE, as a guide.

Gasoline Starting Engine

The gasoline engine may be used to start the diesel engine without the use of starting aids. However, starting aids may be used in lower temperatures to obtain quicker starts.

Position Controls For Starting: Before attempting to start the starting engine, position the controls of both the diesel and starting engine:

1. Check the crankcase oil level in the starting engine to make certain the oil is up to the "full" mark on the gauge.
2. Pull the compression release lever (1) toward the inlet manifold, to the compression released position (2).

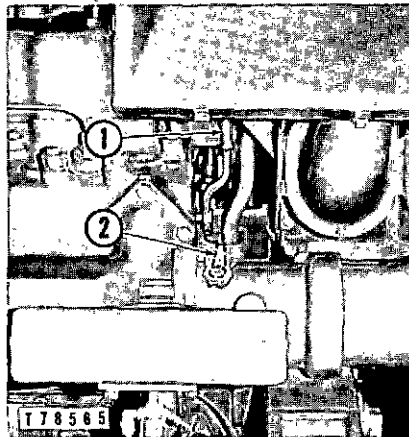

COMPRESSION RELEASE CONTROL LEVER

1-Compression release lever in run position. 2-Released position.

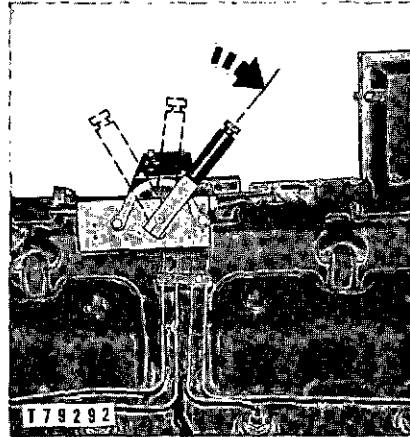

GOVERNOR CONTROL LEVER IN SHUT-OFF POSITION

3. Move the governor control lever toward the rear of the engine to the shut-off position so the fuel injection pumps are closed.
4. The transmission control lever (4) must be in the HIGH position for starting the diesel engine.

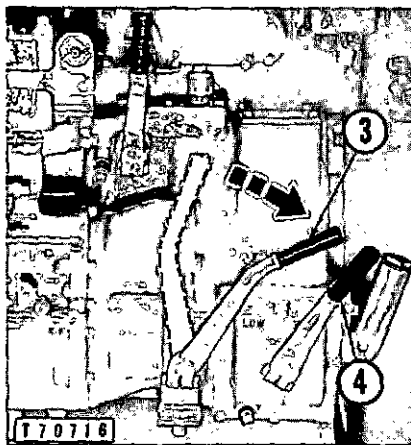

CONTROLS POSITIONED FOR STARTING

3-Clutch control lever in brake applied position. 4-Transmission control lever in HIGH position for starting the diesel engine.

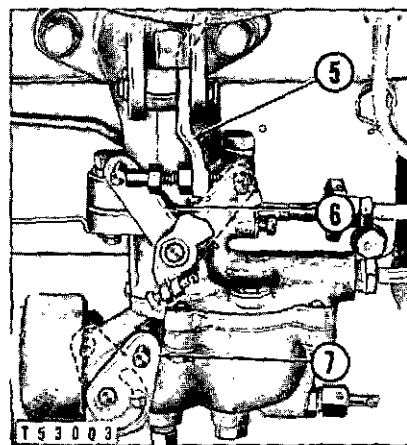

STARTING ENGINE CONTROLS

5-Idling latch, 6-Throttle control lever, 7-Choke control lever.

5. See that the starting engine clutch is disengaged by moving the clutch control lever to the rear of the diesel engine to the brake applied position (3).
6. Open the starting engine fuel valve by turning the fuel valve control, on the sediment bowl, in the counterclockwise direction.
7. Turn the starting engine choke control lever (7) clockwise to choke the engine.
8. Move the idling latch (5) to hold the throttle control lever (6) in the $\frac{1}{4}$ to $\frac{1}{2}$ engine speed position.
9. Turn ON the magneto switch.

Starting The Starting Engine: The starting engine may be started manually or by means of the starting engine electric starter if so equipped.

Helpful suggestions for starting the starting engine in cold weather are in the topic, **STARTING IN COLD WEATHER.**

Manual Starting

1. Insert the crank into position and crank until the engine starts. **Pull the crank through a compression stroke. DO NOT attempt in any manner to spin or push the crank through a cranking arc. Crank until the engine starts.**
2. Move the choke control counterclockwise when the engine will run without choking. Temperature and altitude will vary the length of time it is necessary to have the choke on. Actual experience in starting will determine this interval.

When the engine starts, keep the engine speed low until the crank-case lubricating oil has a chance to warm up and better lubricate the engine.

Electric Starting

1. Press the electric starter switch to crank the engine. **Do not run the starter for more than thirty seconds at a time. Then, allow two minutes intermission for cooling before using it again.** If the electric starter pinion disengages for any reason before the engine starts, release the starter switch and wait until the starting motor stops turning and the starting engine stops "rocking" before again pressing the starter switch.
2. Move the choke control counterclockwise when the engine will run without choking. Temperature and altitude will vary the length of time it is necessary to have the choke on. Actual experience in starting will determine this interval.

When the engine starts, keep the engine speed low until the crank-case lubricating oil has a chance to warm up and better lubricate the engine.

Starting The Diesel Engine: When using the gasoline starting engine, the steps to start the diesel engine should be carefully followed to prevent damage to the starter pinion or the flywheel ring gear.

1. Move the idling latch (5) up to allow the starting engine to run at full governed speed.

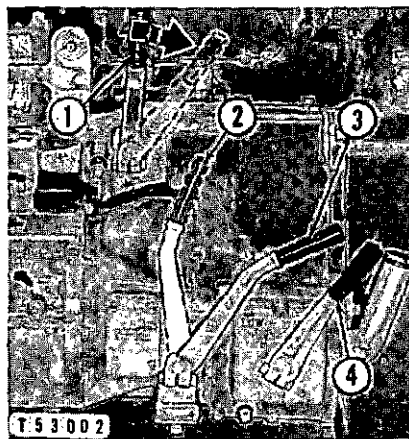

STARTING PINION AND CLUTCH CONTROL LEVERS

- 1-Pinion control lever. 2-Clutch control lever engaged position. 3-Clutch control lever in brake applied position.
4-Starting engine transmission control lever.

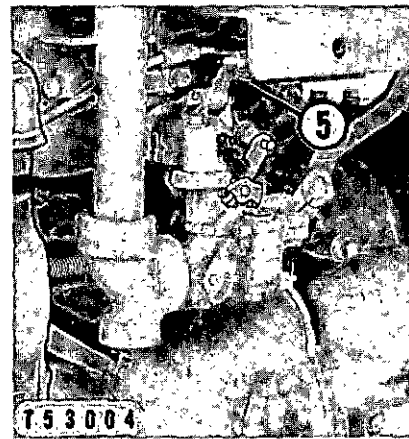

STARTING ENGINE THROTTLE AND CHOKE CONTROL POSITIONS FOR HIGH IDLE SPEED

- 5-Throttle control idling latch up to allow full governed speed.

2. Apply the starting engine clutch brake to stop the starter pinion from rotating, by pulling the clutch control lever all the way back and hold it in the brake applied position (3).
3. Engage the starter pinion with the flywheel ring gear by pulling back on the starter pinion control lever (1), then release the clutch brake and partially engage the clutch to be sure of full engagement of the starter pinion.
4. Engage the starting engine clutch by pushing the lever forward to position (2). If the engine slows to the stalling point when the clutch is engaged, as it might in cold weather, disengage the clutch and let the engine pick up speed again. If the normal cranking speed cannot be reached with the transmission control lever in HIGH speed position, the starting engine transmission will be found to be quite beneficial. See the topic STARTING IN COLD WEATHER.
5. Push the compression release control lever away from the inlet manifold to the diesel engine run position when the starting engine is cranking the diesel engine at normal cranking speed.

The heat generated when the starting engine is cranking the diesel engine against compression, and the circulation of the coolant by the starting engine water pump through the diesel engine warms the cylinders, pistons, and combustion chambers to the starting temperature.

Allow the starting engine to crank the diesel engine against compression for a few minutes to add heat to the diesel engine before starting it. Actual experience will determine the length of time necessary to crank the diesel engine to warm it sufficiently to assure easy starting. Cold temperatures will require longer periods of cranking against compression before injecting fuel.

6. Move the governor control lever to approximately half engine speed position.

GOVERNOR CONTROL LEVER IN
APPROXIMATELY HALF ENGINE
SPEED POSITION

◆

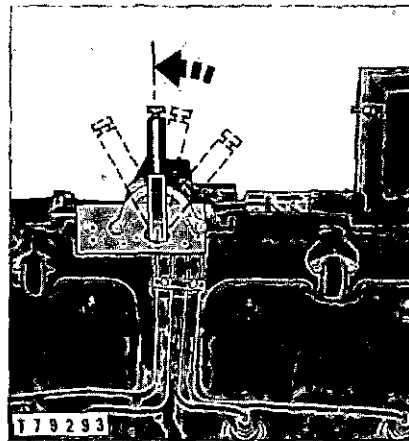

After the diesel engine starts, reduce engine speed to low idle with no load. Do not apply any load to the engine or increase engine speed until normal oil pressure is indicated on the gauge. Avoid unnecessary accelerating of the engine before operating temperatures are obtained. When the gauge indicates normal oil pressure, the engine should be allowed to run for five minutes with the governor control lever at approximately half speed position before applying the load. During this period the engine gauges should be observed for proper readings as explained in the topic, GAUGES.

When the diesel engine begins to run, the starter pinion automatically disengages, but it is necessary to disengage the starting engine clutch.

An ether aid can be used for quicker starting in lower temperatures, spray ether into the air cleaner inlet of the diesel engine at this point in the starting operation. See the topic, STARTING IN COLD WEATHER.

If the diesel engine is thoroughly heated but does not start, see that everything is correctly set for starting. If smoke has been coming from the diesel engine exhaust pipe, fuel has been reaching the cylinders. If no smoke is evident when the governor control lever is in the half engine speed position, check the fuel supply. If the diesel fuel tank is empty, or if the valve was closed, fill the tank or prime the fuel system as outlined under the topic, PRIMING THE FUEL SYSTEM. In case there may be water or dirt in the fuel system, or if the fuel injection equipment is suspected, see the topic, FUEL INJECTION EQUIPMENT.

7. Disengage the starting engine clutch by pulling back on the control lever.
8. Stop the starting engine by moving the throttle control and latching it in idling position. Close the starting engine fuel valve, allowing the engine to burn all the fuel in the carburetor. Then turn OFF the magneto switch.

Electric Starting

The diesel engine electric starting motor can be used successfully in atmospheric or engine room temperatures of 60°F. (16°C.) or above **without** the use of a starting aid. **It is not advisable** to use the diesel engine electric starting motor in temperatures below 60°F. (16°C.) without the use of a starting aid. See the topic, STARTING IN COLD WEATHER. Even when a starting aid is used in temperatures below 32°F. (0°C.), it is advisable to use crankcase lubricating oil of a lower viscosity in the engine crankcase to reduce the cranking effort required. See the topic, TYPE OF LUBRICANTS AND SAE GRADES TO USE.

The engine must be kept in the best mechanical condition possible, the batteries kept fully charged and all terminals kept clean and tight for satisfactory performance of the starting system in lower atmospheric or

room temperatures. In extremely cold temperatures the use of an engine room heater or cooling system auxiliary heater will make starting easier.

Position Controls for Starting: Before attempting to start the diesel engine the controls should be correctly positioned as follows:

1. Normally the compression release control shaft remains in the run position, unless it is desired to crank the engine for some purpose other than starting.
2. Disengage the flywheel clutch or remove any load possible from the engine.
3. Move the governor control lever to approximately half engine speed position.

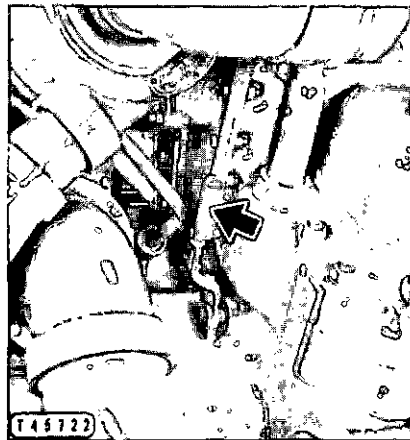

COMPRESSION RELEASE
LEVER IN RUN POSITION

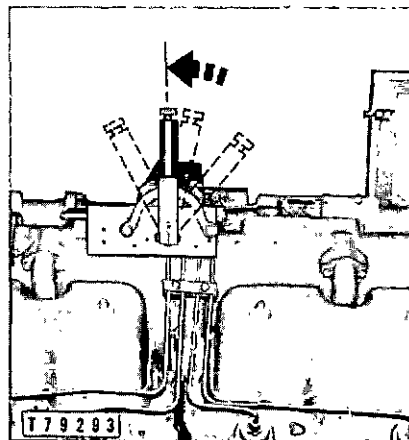

GOVERNOR CONTROL LEVER IN
APPROXIMATELY HALF ENGINE
SPEED POSITION

Starting The Diesel Engine: After positioning the controls correctly, the diesel engine may be started as follows:

1. Press the starter switch to crank the engine against compression.
2. If the engine does not start in a few seconds, continue to crank the diesel engine but shut off the fuel supply by moving the governor control lever to the shut-off position for about ten seconds to clear the cylinders of raw fuel.
3. If the diesel engine fails to start within **thirty seconds**, release the starter switch and wait **two minutes** to allow the electric starting motor to cool before using it again.
4. If the electric starting motor pinion is disengaged for any reason before the engine starts, wait until the electric starting motor stops rotating and the diesel engine stops "rocking" before again pressing the starter switch.

After the diesel engine starts, reduce engine speed to low idle with no load. Do not apply any load to the engine or increase engine speed until normal oil pressure is indicated on the gauge. Avoid unnecessary accelerating of the engine before operating temperatures are obtained. When the gauge indicates normal oil pressure, the engine should be allowed to run for five minutes with the governor control lever at approximately half speed position before applying the load. During this period the engine gauges should be observed for proper readings as explained in the topic, GAUGES.

Air Starting

The diesel engine air starting motor **can** be used successfully in atmospheric or engine room temperatures or 60°F. (16°C.) or above without the use of a starting aid. **It is not advisable** to use the diesel engine air starting motor in temperatures below 32°F. (0°C.) without the use of a starting aid. See the topic, STARTING IN COLD WEATHER. Even when a starting aid is used in temperatures below 32°F. (0°C.), it is *advisable* to use crankcase lubricating oil of a lower viscosity in the engine crankcase to reduce the cranking effort required. See the topic, TYPE OF LUBRICANTS AND SAE GRADES TO USE.

An installation with 250 pounds air pressure in a 28 cubic feet (790 liters) air receiver should provide an adequate volume of air for starting the diesel engine. The air pressure should be regulated to 100 pounds pressure before the air enters the control valve.

Position Controls For Starting: Before attempting to start the diesel engine the controls should be correctly positioned as follows:

1. Normally the compression release control shaft remains in the run position, unless it is desired to crank the engine for some purpose other than starting.
2. Disengage the flywheel clutch or remove any load possible from the engine.

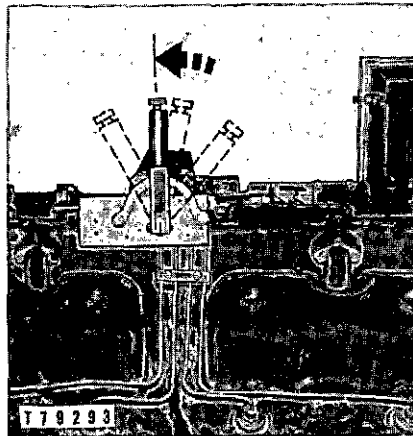

GOVERNOR CONTROL LEVER IN
APPROXIMATELY HALF ENGINE
SPEED POSITION

3. Move the governor control lever to approximately half engine speed position.

Starting The Diesel Engine: After positioning the controls correctly, the diesel engine may be started as follows:

1. Pull up on the air valve control to crank the engine against compression.
2. If the engine does not start in a few seconds, continue to crank the diesel engine but shut off the fuel supply by moving the governor control lever to the shut-off position for about ten seconds to clear the cylinders of raw fuel.
3. If the air starting motor pinion disengages for any reason before the engine starts, release the air valve control and wait until the engine stops "rocking" before again pulling up on the air valve control.

AIR VALVE CONTROL

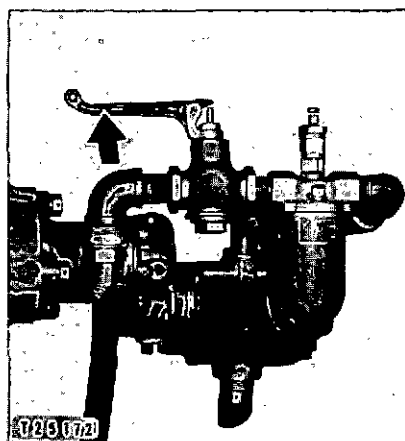

After the diesel engine starts, reduce engine speed to low idle with no load. Do not apply any load to the engine or increase engine speed until normal oil pressure is indicated on the gauge. Avoid unnecessary accelerating of the engine before operating temperatures are obtained. When the gauge indicates normal oil pressure, the engine should be allowed to run for five minutes with the governor control lever at approximately half speed position before applying the load. During this period the engine gauges should be observed for proper readings as explained in the topic, GAUGES.

OPERATING STARTING AIDS

Starting the diesel engine at temperatures above 60°F. (16°C.) using the electric starter, or 32°F. (0°C.) using the air starter, may be accomplished without the use of starting aids as instructed in the preceding topics.

STARTING AID CHART

STARTING TEMPERATURE	STARTING METHOD	STARTING AID	HEATING TIME TO USE AND/OR ETHER AID
Above 60°F.	Electric	None	None
	Air or Gasoline	None	None
Between 60°F. and 32°F.	Electric	Glow Plugs	1 Minute
		Ether	Ether Aid
Between 32°F. and 0° F.	Electric	None	None
		Ether	Ether Aid
	Air or Gasoline	Glow Plugs and Ether	1 to 2 Minutes and Ether Aid
		Glow Plugs	1 to 3 Minutes
		Ether	Ether Aid
		Glow Plugs and Ether	1 to 2 Minutes and Ether Aid
Between 0°F. and - 10°F.	Electric, Air or Gasoline	Ether	Ether Aid
		Glow Plugs and Ether	3 to 5 Minutes and Ether Aid
Below - 10°F.	Air or Gasoline	Glow Plugs or Ether, or Both	Heat cooling system and crankcase oil

When using the electric or air starting motor in lower temperatures, the glow plug starting aid, an ether aid, or both should be used. Pressure ether dispensers and commercially available, engine mounted ether dispensers are available and can be used as an aid in low temperature starting. Only experience can determine the temperatures at which the starting aid should be used. The controls should be positioned as instructed in the topic covering the method of starting to be used, and the following additional instructions should be carefully followed. This will permit the quickest possible start and conserve the battery or air supply. See the STARTING AID CHART.

When using ether for starting, continue cranking until the engine starts. However, do not run the **electric** starting motor for more than 30 seconds at a time, then allow 2 minutes intermission before using it again.

Starting Between 60°F. and 32°F.

The use of starting aids between these temperatures is needed only when electric starting is used to start the diesel engine.

1. Move the HEAT and START switch to the HEAT position for the length of time necessary. See the STARTING AID CHART.

NOTE

Each glow plug uses approximately 4 amperes while the switch is in the HEAT position. This is actually a small amount in comparison to the starting motor load of possibly as many as 800 amperes that is imposed on the battery when the switch is in START position.

HEAT AND START SWITCH

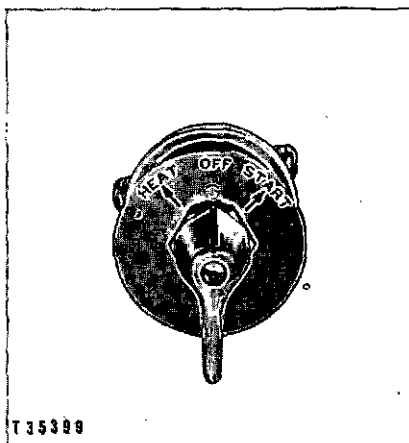

2. Move the HEAT and START switch to the START position. As soon as the engine starts, return the switch to the HEAT position and hold it there until the engine begins to run smoothly.

If the engine fails to start after 10 seconds of cranking, move the switch to the HEAT position for about 30 seconds before cranking the engine again. When the starting motor is cranking, the battery voltage is reduced and the glow plugs cool. Reheating them after 10 seconds of cranking makes the glow plugs more effective and conserves the battery. When the engine starts, return the switch to HEAT position for few seconds or for a period long enough to assure that the engine will continue to run.

After the diesel engine is running smoothly, reduce engine speed to low idle with no load. Do not apply any load to the engine or increase engine speed until normal oil pressure is indicated on the gauge. Avoid unnecessary accelerating of the engine before operating temperatures are obtained. When the gauge indicates normal oil pressure, the engine should be allowed to run for five minutes with the governor control lever at approximately half speed position before applying the load. During this period the engine gauges should be observed for proper readings as explained in the topic, GAUGES.

Do not turn the HEAT and START switch to the HEAT position while the engine is warm and running.

3. If the diesel engine fails to start within **thirty seconds**, release the starter switch and wait **two minutes** to allow the electric starting motor to cool before using it again.

4. If the electric starter pinion is disengaged for any reason before the engine starts, wait until the electric starter stops rotating and the diesel engine stops "rocking" before again turning the switch to the START position.

If a pressurized ether dispenser is to be used as a starting aid, move the switch to the START position or press the starter switch. While the electric starter is turning the diesel engine, carefully spray ether toward the air cleaner inlet until the engine starts. If the diesel engine fails to start within **thirty seconds**, release the starter switch and wait **two minutes** to allow the electric starter to cool before using it again.

NOTE

Use only enough ether to start the diesel engine or keep it running if the engine starts to stall.

Starting Between 32°F. and -10°F.

Starting between 32°F. (10°C.) and -10°F. (-23.3°C.), using either the electric or air starting motor, may be accomplished with the use of starting aids in the following manner.

1. Move the HEAT and START switch to the HEAT position for the length of time necessary. See the STARTING AID CHART.

NOTE

Each glow plug uses approximately 4 amperes while the switch is in the HEAT position. This is actually a small amount in comparison to the starter load of possibly as many as 800 amperes that is imposed on the battery when the switch is in START position.

2. Move the HEAT and START switch to the START position, press the starter switch or pull upon the air valve control to crank the engine.

While the starter is turning the diesel engine, carefully spray ether toward the air cleaner inlet until the engine starts. If the electric starter is being used to start the diesel engine and the engine fails to start in thirty seconds, release the starter switch and wait two minutes to allow the electric starter to cool before using it again.

3. As soon as the engine starts, return the switch to the HEAT position and spray ether toward the air cleaner inlet as required to prevent stalling. Hold the switch in the HEAT position until the engine begins to run smoothly.

After the diesel engine is running smoothly, reduce engine speed to low idle with no load. Do not apply any load to the engine or increase engine speed until normal oil pressure is indicated on the gauge. Avoid unnecessary accelerating of the engine before operating temperatures are obtained. When the gauge indicates normal oil pressure, the engine should be allowed to run for five minutes with the governor control lever at approximately half speed position before applying the load. During this

period the engine gauges should be observed for proper readings as explained in the topic, GAUGES.

NOTE

Use only enough ether to start the diesel engine or keep it running if the engine starts to stall.

Starting Below -10°F .

When starting in temperatures below -10°F . (-23.3°C .), the coolant in the cooling system and the crankcase lubricating oil should be warmed. When heating the cooling system in these lower temperatures, the coolant should be maintained between $+15^{\circ}\text{F}$. (-9.5°C .) and $+30^{\circ}\text{F}$. (-1°C .) for easy cranking, quicker starting and rapid oil distribution. Follow the starting procedures outlined above and in the topic, STARTING IN COLD WEATHER.

When electric starting is used, an oversize or paralleled battery may be required to maintain cranking speeds.

GAUGES

After the engine starts, and at frequent intervals while the engine is operating, the engine gauges should be observed for proper readings as explained in the following paragraphs:

GAUGES

- 1-Crankcase lubricating oil pressure gauge.
2-Water temperature gauge.
3-Fuel pressure gauge.

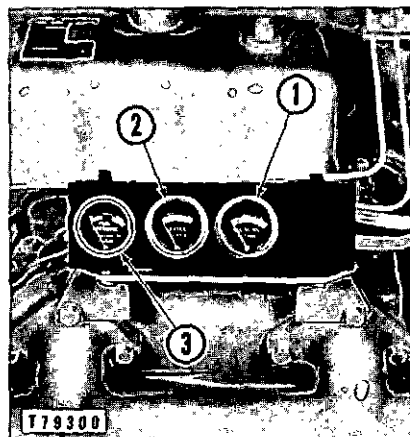

Oil Pressure Gauge: Immediately after the engine has started, check the crankcase lubricating oil pressure gauge (1) to see that it is registering. When the engine is running at rated engine speed the gauge should register in the "OPERATING RANGE." A lower pressure reading is normal at low idling speeds. If no pressure is indicated, investigate at once.

Water Temperature Gauge: The indicator on the water temperature gauge (2) should register in the "OPERATING RANGE". The water temperature regulators within the diesel engine cooling system are designed to give an approximate minimum coolant temperature of 180°F . (82°C .) under full load. The maximum operating temperature will vary according to the air temperature and load factor, but should never exceed boiling temperature at the prevailing altitude.

Fuel Pressure Gauge: The indicator on the fuel pressure gauge (3) should register in the NORMAL (green) range. See the topic, FUEL SYSTEM.

Ammeter: On engines equipped with a charging generator or alternator, the ammeter should be checked to see that the indicator is registering in the charging range (indicator on the + side of zero). If the indicator registers in the discharging range (indicator on the - side of zero) investigate at once. If the ammeter shows no charge it may be that the circuit breaker in the junction box is open, if the engine is so equipped. To close the circuit breaker press the reset button on the junction box and again check the ammeter to see if it is registering in the charging range. When it is necessary to close the circuit breaker after each start, it indicates the regulator is not functioning properly. See the topic, ALTERNATOR REGULATOR or GENERATOR REGULATOR.

STARTING THE LOAD

When the engine has run long enough to warm up, move the governor control lever to the SLOW position to bring the engine to low idle speed. Move the marine gear control lever in the desired direction until it snaps in place.

When referring to propeller rotation, it is assumed that a person is standing astern of (behind) the vessel and faces forward (toward the front). Rotation of the propeller is determined by the direction of rotation of the upper part of the propeller when the vessel is moving forward. Thus, a clockwise rotation would define a right-hand propeller, while counterclockwise refers to a left-hand propeller. Whether a given rotation is forward or reverse will depend upon the propeller.

To prolong the life of the clutches and gears reduce the engine speed when reversing the direction of rotation of the reverse gear in normal operation.

STOPPING THE LOAD

When it becomes necessary to stop transmitting power, move the governor control to the reduced speed position and then move the marine gear control lever to the neutral position.

STOPPING THE DIESEL ENGINE

Correctly stopping the diesel engine will allow some of the hot areas in the engine to gradually cool, thus extending engine service life. The correct diesel engine stopping procedure is as follows:

1. After the normal load is removed from the engine allow it to idle five minutes with the governor control lever at half engine speed position.
2. Reduce engine speed to low idle speed and allow the engine to run for thirty seconds.

3. Stop the diesel engine while it is running at low idle speed by moving the governor control lever to the shut-off position. Do not accelerate the engine speed above low idle before stopping the engine.

Close the diesel engine fuel tank valve. Close the sea valve to shut off the raw water supply.

If the engine must stand without shelter, cover the exhaust pipe (including starting engine exhaust pipe if so equipped) to exclude rain or snow. If the temperature is below freezing, or if freezing weather is expected before the engine will be started again, see that the cooling system is adequately protected against freezing. See the topic, COOLING SYSTEM, for information about anti-freeze solutions and cooling system draining.

DAILY CARE

Attention should be given to the operations mentioned in this topic, every 10 service hours or daily, whichever occurs first.

A daily check of the engine should be made to see if there are any loose nuts, bolts or parts worn to such an extent that they are no longer serviceable. If corrective steps are taken immediately on discovery of loose or worn parts, fewer forced stops and more economical operation will result. Points to be checked daily, or every 10 service hours, are as follows:

1. Exhaust and inlet manifold, turbocharger mounting bolts and air cleaner connections, inspect for tightness. The manifolds should be air tight.
2. Cooling system, add coolant or anti-freeze if necessary. Be sure the filler cap seal is in good condition and that the cap is installed tightly.
3. Fuel pressure gauge, inspect with engine running to see that indicator is not in red range.
4. Diesel engine air cleaner, with the engine stopped, inspect for dirt in cleaner body when operating conditions are extremely dusty.
5. Check the operation of the turbocharger to see that no vibration or excessive noise is present. The "muffled high pitched whine" is the normal sound of the turbocharger. If the turbocharger is defective it will usually be noisy only under load.

When the diesel engine is operating continuously, the starting engine should be run for a few minutes each day to dissipate condensation and renew the oil film on the bearing surfaces and cylinder walls

Fill the fuel tank at the end of the day's run. See the topic, CARE OF THE FUEL SUPPLY TANK for other periodic care.

Dirt should not be allowed to accumulate on the engine. A few minutes spent daily in keeping it clean are well repaid in improved appearance, and greater ease and safety in operation and maintenance.

STARTING IN COLD WEATHER

If the starting systems and the diesel engine have been given adequate and regular maintenance service, and the precautions necessary for cold weather operation are taken, ordinary cold weather will not cause difficulty in starting or loss of efficiency.

Lubricants: As the starting atmospheric temperatures become lower, where warm housing facilities are not available, lubricants of lower viscosity should be used. In temperatures below -10°F . it is advisable to warm the lubricants. See the topic, TYPE OF LUBRICANTS AND SAE GRADES TO USE.

Coolant: When the temperature is below freezing, sufficient anti-freeze solution should be used in the cooling system to prevent freezing. Commercial solutions are available for this purpose or glycerine may be used. See the topic, COOLING SYSTEM.

The liquid in the cooling system may be warmed to make starting easier and quicker. When warming anti-freeze solutions, keep away from flames, as some of these solutions may be inflammable. Avoid getting the solution hot, and even a warm solution should be poured very slowly into a cold cooling system to prevent damage by sudden expansion.

Fuel: Fuel must be "free flowing" enough to flow readily through the fuel lines at the lowest temperature at which the engine will be started and operated. For additional information on this subject, see the topic, FUELS.

Electrical Equipment: During cold weather, more attention should be given to the condition of the battery. It should be tested frequently and charged as often as necessary to insure sufficient power for starting. All switches and connections in the electrical system should be inspected and kept in good condition to prevent losses through improper contacts. See the topic, BATTERY.

Starting the Starting Engine: If the engine has been standing without shelter in extremely cold weather, the following suggestions will materially assist starting.

Crank the starting engine several revolutions with the magneto switch off, the choke ON, the throttle slightly open and the starting engine clutch disengaged. This will better distribute oil to the bearings and cylinder walls.

Sometimes moisture, or fuel which has not vaporized, collects on the starting engine spark plugs. They may be dried out by removing them and pouring gasoline over the electrodes. Ignite the gasoline and allow it to burn. **Use care to prevent fire.**

Pouring a small amount of gasoline on the electrodes before they are replaced in the engine is more effective in promoting combustion than priming the cylinders with gasoline. A small amount of gasoline in the

cylinders will remove the film of oil from the cylinder wall and interfere with compression.

Follow the starting procedure covered in the topics, GASOLINE STARTING and either MANUAL STARTING or ELECTRIC STARTING whichever applies.

When the engine starts, keep the engine speed low until the crankcase lubricating oil has a chance to get warm and better lubricate the engine.

Starting the Diesel Engine: When starting in temperatures below -10°F . (-23°C .) using gasoline starting, the coolant in the cooling system and the crankcase lubricating oil should be warmed. When heating the cooling system in these lower temperatures, the coolant should be maintained between $+15^{\circ}\text{F}$. (-9.5°C .) and $+30^{\circ}\text{F}$. (-1°C .) for easy cranking, quicker starting and rapid oil distribution.

When using the electric or air starting motor in lower temperatures, an ether aid should be used. Pressure ether dispensers are available and can be used as an aid in low temperature starting. Starting aids may also be used with the gasoline starting engine method of starting, however, only experience can determine the temperatures at which the starting aid should be used. The controls should be positioned as instructed in the topic covering the method of starting to be used. While the starter (either gasoline, electric or air) is turning the diesel engine, carefully spray ether toward the air cleaner inlet until the engine starts.

NOTE

Use only enough ether to start the diesel engine or keep it running if the engine starts to stall. Use of ether in excess of amount necessary to start the engine can result in damage to internal engine parts.

If the diesel engine is being started with the gasoline starting engine and the pinion clashes and will not engage with the ring gear, proceed as follows:

1. Stop the starting engine after the lubricating oil is thoroughly warm.
2. Engage the starter pinion. (It may be necessary to rotate the starter pinion by the use of the electric starter or hand crank.)
3. Disengage the starting engine clutch by pushing the control lever to the rear.
4. Restart the starting engine.
5. With the starting engine running at high idle speed, engage the starting engine clutch to start the diesel engine.

If the normal cranking speed cannot be reached with the transmission control lever in HIGH speed position, the starting engine transmission will be found quite beneficial.

To use the starting engine transmission for starting a cold engine proceed as follows:

1. Disengage the starting engine clutch by moving the starting engine clutch lever to the disengaged position (1).
2. Move the starting engine transmission shift lever into LOW position (2). The transmission can be shifted from one speed to the other when

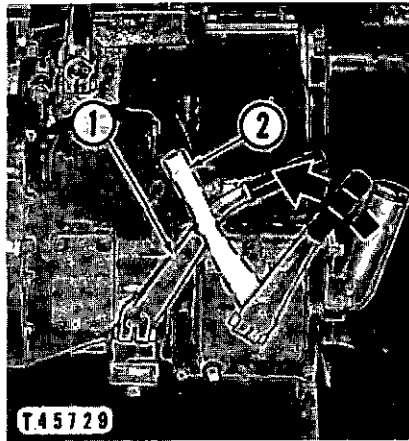

**STARTING ENGINE TRANSMISSION
CONTROL LEVERS**

1-Starting engine clutch lever in disengaged position. 2-Transmission shift control lever when moved to low position.



**COMPRESSION RELEASE LEVER
IN RUN POSITION**

the starter pinion lever is in either engaged or disengaged position, but the clutch must be disengaged.

3. Engage the starting engine clutch and after the cranking effort is reduced, move the compression release lever to the run position.

NOTE

Diesel engine governor control lever should be in shut-off position when cranking with the starting engine in LOW.

4. Allow the starting engine to turn the diesel engine for several minutes as the heat of compression will assure easy starting.
5. Disengage the starting engine clutch, shift the starting engine transmission to HIGH. With the starting engine running at high idle speed, engage the starting engine clutch to start the diesel engine.

NOTE

When the starting engine has cranked the diesel engine for several minutes, push the reset button on the safety shut-off control and see that the safety shut-off control reset knob is all the way out so that the diesel engine will start.

When electric starting is used, an oversize or paralleled battery may be required to maintain cranking speeds.

STORAGE

Lubricate all points mentioned in the lubrication chart if the engine is to be stored or left standing for any length of time. This will protect against rusting.

Diesel Engine: If the engine is to be stored or left standing for a long period of time, the lubricating oil may drain away from the cylinder walls and piston rings. This lack of lubricant permits the rings and liners to rust. It also permits unnecessary wear caused by metal-to-metal contact between the pistons, rings and liners when the engine is started before fresh oil has reached these surfaces. The lack of lubricant may not cause any noticeable change in engine operation after it has been started but it does contribute to shorter engine life.

The oil film should be renewed by running the engine once a week until it is thoroughly warm. This will circulate the oil and prevent rusting from condensation.

Starting Engine: The oil film should be renewed in the starting engine by running the engine once a week until it is thoroughly warm.

Cooling System: If the temperature will be below freezing, the cooling system should be drained if it has not been serviced as instructed in the topic, COOLING SYSTEM.

Raw Water Cooling System: When the temperature is below freezing, the raw water system should be drained at the low points in the system after each day's run. Refer to the topic, COOLING SYSTEM.

Battery: Keep the battery charged by running the engine once a week or taking the battery to your Caterpillar dealer for charging.

When replacing a battery that has been removed, make certain the correct battery post is connected to the ground cable. Failure to connect the battery terminal to the correct post will damage the voltage regulator and the alternator. See the topic, WIRING.

Fuel Tank: If the engine is to be stored or left standing longer than a normal work day, fill the tank with clean fuel to drive out moisture laden air. This will prevent condensation and rust from forming inside the tank. If the machine is to be stored with the fuel tank empty or partially filled, commercially available rust preventive Vapor Phase Inhibitor

Crystals should be placed in a cloth bag and hung inside the tank filler opening to prevent moisture and rust from collecting. Crystals should not be dropped into the fuel as they will not function when saturated with fuel. *Remove the crystals before the fuel tank is to be refilled with fuel.*

ALTITUDE OPERATION

The maximum turbocharger speed is determined by the fuel rack setting, the high idle speed, turbine nozzle and the altitude at which the engine is operated. The rack and high idle speed settings have been established to permit the engine to be operated at the altitude marked on the warning plate on the front valve cover on the right side of the engine. The turbine nozzle is the same for all altitudes, but the engine fuel rack setting and high idle speed vary with altitude. If the fuel rack setting is greater than specified for the altitude at which the engine is being operated or the high idle speed is too high, **serious damage or injury due to turbocharger overspeeding may result.**

The maximum altitude at which the engine may be operated at the present setting is marked on the warning plate on the front valve cover on the right side of the engine. The governor housing and turbocharger are sealed for your protection. **Changes to the turbocharger, fuel rack setting, or high idle speed should be made only by your Caterpillar dealer.**

The engine can be operated at a lower altitude than marked on the warning plate without danger of turbocharger overspeeding, but with slightly less than maximum performance, however the fuel rack setting must be changed when operated at a lower altitude to get full power. **When operated at a higher altitude, the fuel rack setting must be changed by your Caterpillar dealer.** After making any changes, a new altitude limit will be marked on the warning plate and the governor housing will be resealed for your protection. This will assure you correct settings have been made.

IMPORTANT: Consult your Caterpillar dealer before operating at a higher altitude than is marked on the warning plate.



Maintenance Instructions

Marine Gear information is covered in the Operation and Maintenance Instruction Book for the Marine Gear

The foregoing paragraphs have been devoted to instructions which are necessary for day-to-day operation of the engine. The following topics give detailed instructions regarding the care and adjustment of the various parts.

AIR CLEANERS

The dry type air cleaners are used without oil.

Regular service intervals, along with close visual inspection of the dry type air cleaner, are necessary for proper cleaning of the engine inlet air. The service interval will vary with the weather and working conditions. During dry, dusty months where dust conditions are severe, it will be necessary to service the air cleaner frequently. In damp weather and other conditions of little or no dust, the service interval can be extended.

Diesel Engine Dry Type Air Cleaner

Visual inspection of the gaskets and seals is important in keeping dust from by-passing the air cleaner filter element. Air leakage can upset proper air cleaner action. If the condition of any of the replaceable seals and gaskets is questionable, replace them. If the sealing ends of the filter element or the element pleats are damaged, replace the element.

To extend the service life of the element, the exhaust and air cleaner inlet pipes should be arranged so that exhaust and/or oil fumes do not enter the engine air cleaner.

The air cleaner service indicator is connected to the air inlet passage between the air cleaner and the engine. The air cleaner service indicator contains a red marked piston which gradually rises with restriction to the air flow. When the entire piston is visible it will lock in this position. This

AIR CLEANER SERVICE INDICATOR



T-67D-9, 9:2

indicates a need for air cleaner service. The piston will remain in this position whether or not the engine is running. After servicing the air cleaner, reset the piston by depressing the plunger in the bottom of the indicator.

Excessive engine exhaust smoke and/or loss of power may indicate the need for servicing the air cleaner.

Filter Element: Every 50 to 250 service hours, depending on dust conditions, remove the filter element for inspection and cleaning. This period may be extended in clean atmosphere and can only be determined by experience. **Never service the air cleaner while the engine is running.**

An extra filter element should be kept on hand for replacement or for use in the air cleaner while the element that was removed is being cleaned.

Panel Type Air Cleaner:

1. To remove filter element (1), unfasten the six clamps (3) which holds the door to the base, remove door (2) and filter element (1).

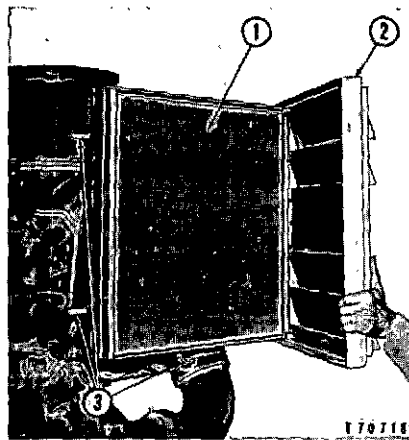

DRY TYPE AIR CLEANER

1-Filter element. 2-Door. 3-Clamps.

2. Inspect the element and if it is damaged, install a new element. The metal filter frame can be damaged by dropping or bumping. A bent frame may not seal properly and may allow unfiltered air to enter the engine cylinders causing premature engine wear.
3. Clean the filter element by using one of the methods in the topic FILTER ELEMENT CLEANING.
4. Thoroughly clean all parts of the air cleaner.
5. Install the air cleaner filter element as shown. Channel (5) is on the engine side of the filter element. This channel must be in a horizontal position when installed so as to properly engage clamping ring brace (4).

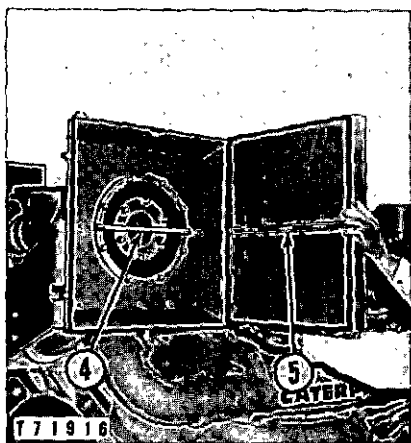

INSTALLING FILTER ELEMENT

4-Clamping ring brace. 5-Channel.



6. Install the door to the base and fasten the six clamps.

If after cleaning, the engine exhaust smoking and/or loss of power has not been corrected, or the restriction has not been reduced, install a new element. **Replace the filter element at least once a year.**

Single-Stage Single-Element Air Cleaner:

1. To remove the filter element, loosen the two wing nuts (1), remove the end cover (2) and the filter element (3).

DRY TYPE AIR CLEANER

1-Wing nut. 2-End cover.
3-Filter element.

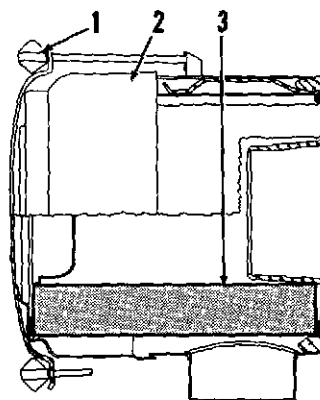

7 38258

2. Inspect the element and if it is damaged, install a new element.

3. Remove any dirt which has accumulated on the bottom of the case

and clean the filter element using one of the methods covered in the topic, FILTER ELEMENT CLEANING.

4. Thoroughly clean all parts of the air cleaner. Inspect the gaskets and install new ones if they are damaged.
5. Assemble the air cleaner. This air cleaner requires no oil.

If after cleaning, the engine exhaust smoking and/or loss of power has not been corrected, or the restriction has not been reduced, install a new Caterpillar element.

Replace the filter element at least once a year.

Filter Element Cleaning

The ends of a filter element can be damaged by bumping or tapping. Bent and/or dented ends cannot seal properly and may allow unfiltered air to enter the engine cylinders thus causing premature engine wear.

Clean the filter element using one of the following methods:

1. Using clean, dry air, at a pressure not to exceed 100 PSI, proceed as follows:

Direct air at an angle against the inside (engine side) of the element to loosen any imbedded dirt. Best results can be obtained by moving the air hose so that air is directed at an angle along the complete length of each pleat.

Blow off loose dirt by directing air against the outside of the element. Repeat this procedure until the element is clean. Make certain that no dirt is inside the element.

2. Using clean water, at a pressure not to exceed 40 PSI, proceed as follows:

Direct water at an angle against the inside (engine side) of the element to loosen any imbedded dirt. Best results can be obtained by using a water hose without a nozzle and moving it so that water is directed at an angle along the complete length of each pleat. Wash off loose dirt by directing water against the outside of the element.

Repeat this procedure until the element is clean. Make certain that no dirt is on the engine side of the element, and thoroughly dry the element before installing it.

3. Some oily and/or sooty deposits can be removed by washing the element in a solution of warm water and a good household non-sudsing detergent. Rinse with clean water and thoroughly dry the element before installing it.

WASHING THE CRANKCASE

Whenever the diesel engine or starting engine oil pan is removed for any reason it should be thoroughly cleaned before it is reinstalled. The oil pump screen should also be cleaned while the oil pan is off the engine.

SUMP PUMP

The lubricating oil sump pump is mounted on the right side of the engine near the flywheel housing. The sump pump provides a convenient method of removing both the diesel engine crankcase lubricating oil and marine gear lubricating oil.

A line or hose connected to the sump pump with a 1/2 inch pipe nipple in place of the plug (1) will allow the oil to be pumped into a suitable container instead of the bilge.

SUMP PUMP
1-Outlet plug. 2-Sump pump handle.
3-Sump pump. 4-Selector valve.

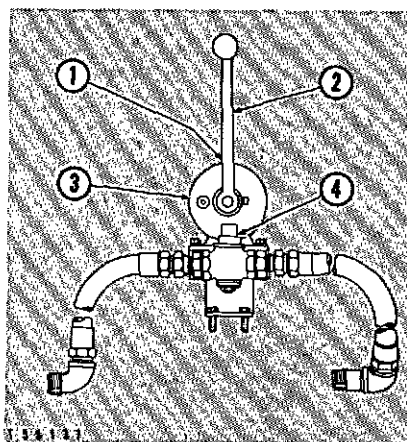

To use the pump proceed as follows:

1. Place a selector valve (4) to the correct position for draining the desired compartment.
2. With plug (1) removed from the outlet and if necessary a hose or pipe connected to the outlet, move the pump handle (2) back and forth until all the oil is pumped from the compartment selected.
3. Remove the pipe or hose and reinstall the plug in the sump pump outlet.

FUELS

As a source of power the diesel engine has two outstanding advantages over the gasoline engine. The first is its lower rate of fuel consumption — and second its ability to use less expensive fuels. In selecting a fuel, it should be pointed out that distillates are especially desirable because, in refining, they are heated to a vaporous state and condensed in another container; thus, all the sediment and residue remain in the still. Always buy the **lowest priced distillate fuel giving satisfactory operation.**

In the United States and Canada, there are two general classes of fuel available for diesel engines. The American Society for Testing Materials (ASTM) has established these classes in their specifications. One class is that group of fuels marketed as fuel oil (domestic furnace oil); the other is that marketed as diesel fuel oil. No. 2 fuel oil and No. 2D diesel fuel oil are recommended for use in Caterpillar Diesel Engines. More expensive "premium" fuels such as No. 1 fuel and No. 1D diesel fuel oil are not necessary or recommended for normal operating conditions.

There is considerable variation in the composition of fuels distributed under the No. 2 grade classifications. For desirable engine service, it is most important to give special attention to pour point, cloud point, filterability, sulphur content and cetane number of the fuel.

Pour Point: The pour point of the fuel has no effect on engine performance, so long as the fuel is fluid enough to flow from the diesel fuel tank to the engine fuel transfer pump. The pour point of the fuel should be at least 10°F. below the lowest atmospheric temperature at which the engine must start and operate. This will generally provide a fuel that will flow readily from the fuel tank to the engine fuel transfer pump. In sub-zero (-18°C.) weather it may be necessary to use No. 1 fuel oil or No. 1D diesel fuel oil to obtain unusually low pour point fuels.

Cloud Point: Cloud point is a low temperature property frequently not reported in fuel characteristics. It is the temperature at which wax crystals become visible, and it is generally above the pour point of the fuel. The cloud point should be below the lowest atmospheric temperature at which the engine will be operated so the filter will not be plugged with the wax formation.

Filterability: A good clean fuel should contain no more than .1% sediment and water. Dirty fuels lead to early filter plugging and in addition, with some fuels, fuel stability and fuel compatibility can result in the formation of gums and resins which also reduce filter life.

Sulphur Content: As the sulphur content of the fuel increases, the oil change periods should be reduced as indicated in the topic, DIESEL ENGINE CRANKCASE LUBRICATING OIL CHANGE PERIODS.

Cetane Number: This is an indication of fuel's ignition quality and should never be less than 35 for Caterpillar Engines. A higher cetane number is required at higher altitudes and for easier starting at low temperatures.

There is no world-wide standardization of diesel fuels and the ASTM classifications are not used in many export territories. Therefore, for best results, consult your Caterpillar dealer because he is familiar with fuels that are marketed in his particular area. He will be glad to advise you.

CARE OF THE FUEL SUPPLY

Keep The Fuel Clean: Too much emphasis cannot be placed on the importance of using only clean diesel fuel. It is important to buy clean fuel, and keep it clean. The best fuel can be rendered unsatisfactory by inadequate storage facilities or careless handling. The clearance between the fuel injection pump plunger and the barrel is very small, actually less than .0001 inch (0.00254 mm.), which makes it evident that the invisible particles of dirt which might pass through the filters can damage these finely finished parts.

Effort should be constantly expended to prevent contamination of the fuel. An important step is to reduce the number of times the fuel must be handled. When the fuel can be delivered by the distributor to fuel storage tanks and then pumped from the fuel storage tank to the diesel engine fuel tank, the handling is reduced to a minimum.

Since natural settling is an effective method of cleaning diesel fuel, the fuel should be allowed to stand at least 24 hours in the fuel storage tank after the tank has been filled before fuel is transferred to the diesel engine fuel tank. Be sure to drain all water and sediment that has settled to the bottom of the storage tank before the tank is refilled. Occasionally, drain all of the fuel and clean the tank thoroughly.

CARE OF THE DIESEL FUEL TANK

Fill the diesel fuel tank at the end of the day, because the incoming fuel will drive out the moisture-laden air and prevent condensation. Every 125 service hours before starting the engine, open the drain cock under the diesel fuel tank and drain off any sediment or water which may have accumulated.

FUEL FILTERING SYSTEM

As the resin impregnated cellulose material fuel filter elements in the fuel filter housing gradually becomes clogged with foreign material, the position of the fuel gauge indicator will work back from the original position in the NORMAL (green) range, to the CAUTION (white) range and later into the OUT (red) range. When the indicator shows in the OUT (red) range, the fuel filter elements should be replaced.

Fuel Filter

Draining Fuel Filter Housing: Every 50 service hours, or even daily in cold temperatures (32°F. or below), drain the filter housing of sediment and water which settles to the bottom of the compartment. Close the diesel fuel tank valve, remove the filter housing drain plugs (2) and open the vent valve (1) in the housing. Replace the drain plugs, and prime the system. See the topic, PRIMING THE FUEL SYSTEM.

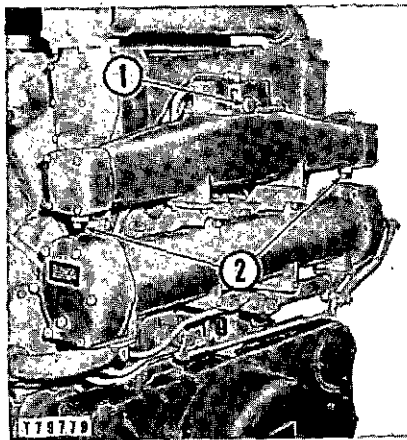

DRAINING FUEL FILTER HOUSING

1-Vent valve. 2-Drain plugs.

Fuel Filter Element: When the element has collected enough contamination to interfere with engine performance, it must be replaced with a new element. The element will continue to collect particles until fuel will no longer flow through it at a rate to maintain maximum engine performance. The element will not discharge its burden into the clean fuel.

The final fuel filter element collects and holds contaminants and cannot be washed or otherwise restored.

Removing Used Filter Elements: To remove the used filter elements, proceed as follows:

1. Close the diesel fuel line valve.
2. Remove the filter housing drain plugs.
3. Open the vent in the filter housing.

REMOVING FUEL FILTER ELEMENTS

1-Housing. 2-End cover.
3-Filter element.

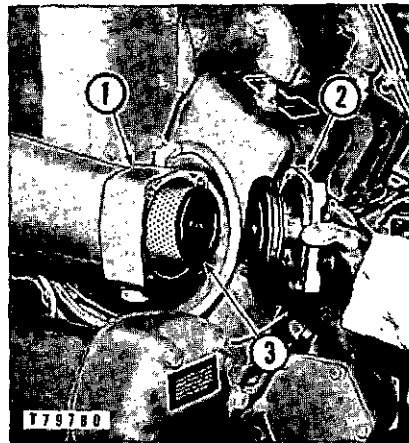

4. Thoroughly clean around the end cover to be removed.
5. Remove end cover (2) from housing (1).
6. Remove the six filter elements (3) and discard them. Both end covers when removed will permit the inside of the housing to be cleaned if so desired.

Installing Filter Element in Housing: To install the element in the housing proceed as follows:

1. Inspect the end cover gasket or gaskets if both end covers have been removed and replace if damaged.
2. Install new Caterpillar filter elements.
3. Install end cover or both covers if both have been removed. Install the drain plugs.
4. Prime the system as outlined in the topic, PRIMING THE FUEL SYSTEM.

Keep New Filter Elements On Hand: An extra set of filter elements should be kept on hand for replacement. Always keep the elements wrapped in their original cartons to insure against dust and dirt accumulations which will shorten the life of the elements if it gets on the outside or may cause damage to the fuel injection equipment if it gets on the inside.

PRIMING THE FUEL SYSTEM

Any time the fuel flow is broken and air is allowed to get into the fuel system, the system must be primed. If air is left in the lines, the fuel system may become air bound, resulting in inability to start the diesel engine or the misfiring of one or more cylinders.

1. Check to see that the diesel fuel tank valve is open.
2. Move the governor control lever to the shut-off position, so the fuel injection pumps are closed.
3. Open the fuel filter vent valve (1) on top of the filter housing.

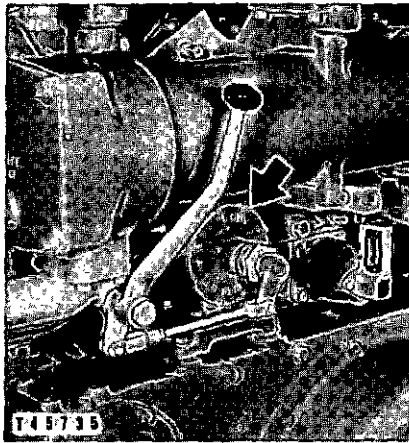

FUEL PRIMING PUMP

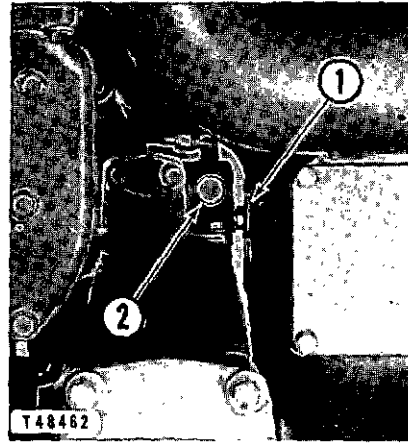

FUEL PRIMING CONTROL

1-Vent valve. 2-Bleed indicator window.

4. Operate the fuel priming pump lever until fuel, with no air bubbles, can be seen through the small round fuel bleed indicator window (2). When the flow of fuel becomes continuous, with no air bubbles, close the vent valve.
5. The fuel injection lines to the cylinders may have to be bled if the engine runs unevenly after priming the system. Bleed the fuel lines one at a time with the engine running. To bleed a fuel injection line loosen the fuel line nut at the cylinder until fuel flows from the loosened nut, then tighten the nut. Continue bleeding each fuel injection line until the engine runs smoothly.

FUEL INJECTION EQUIPMENT

When improper fuel injection is affecting the diesel engine operation, a systematic check should be made to determine the cause. The most likely cause is dirt or water in the fuel. Drain the sediment from the fuel tank and drain the fuel filter housing. Check the fuel pressure gauge as mentioned in the topic, FUEL FILTERING SYSTEM. Replace the filters if necessary. Then prime the fuel system until clean fuel without air bubbles passes through the bleed indicator window. If the fuel system is air bound, priming the system will overcome the difficulty.

When the engine is running irregularly, and smoking, a fuel injection valve may not be spraying the fuel properly.

As the clearance between the plunger and the barrel of a fuel injection pump increases, due to wear, fuel leakage occurs. When the leakage increases to the point where insufficient fuel is injected into the cylinder, a loss of power is noticeable. With the loss of power, hard starting is also encountered.

Fuel Injection Valves

Testing Fuel Injection Valves: Whenever an engine performs in such a manner that a fuel injection valve is suspected of causing trouble, test all fuel injection valves. To test the injection valves, loosen the fuel injection line nuts at the fuel injection valves, one at a time, while the engine is running. When a nut is loosened and the exhaust smoking is completely or partially eliminated and the irregularity in running is not affected, this identifies the probable location of a defective valve and a new one should be installed in that cylinder to definitely determine if the valve removed was defective.

Never wire brush or scrape a fuel injection valve nozzle assembly as this will damage the finely machined orifice. Your Caterpillar dealer has the proper tools for cleaning and testing fuel injection valves.



**LOOSEN FUEL LINE NUTS
TO TEST VALVES**

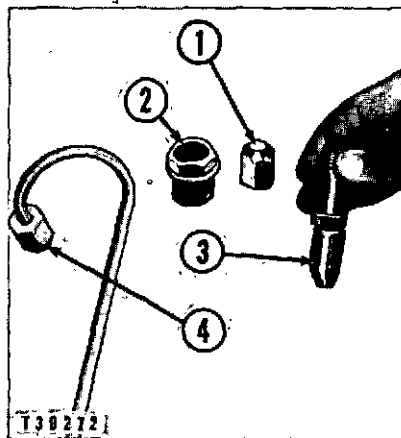

**REMOVING FUEL INJECTION
VALVE**

1-Cap. 2-Retainer nut. 3-Fuel injection valve nozzle assembly. 4-Plug.

Removing Fuel Injection Valves: Before removing a valve use a brush to clean around the valve and connections. Remove the glow plug, if so equipped, to avoid accidental damage to it. See the topic, GLOW PLUGS.

Loosen the fuel injection line at the pump and disconnect it from the valve. Immediately install the plug (4) to prevent dirt from entering the fuel injection line. Remove the valve retainer nut (2) and lift out the fuel injection nozzle assembly (3) and valve body as a unit. If the fuel injection valve will not be immediately installed, the cap (1) should be put on the valve body to prevent dirt entering the valve body and nozzle assembly.

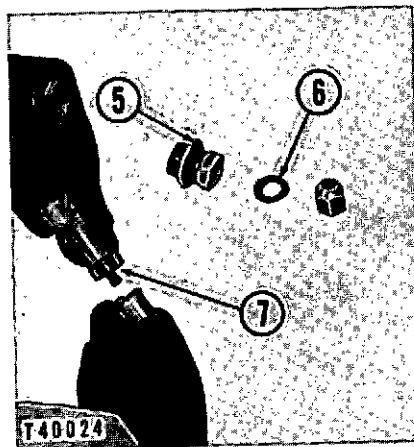

INSTALLING FUEL INJECTION VALVE

5—Large seal. 6—Small seal. 7—Injection valve body.

Installing Fuel Injection Valves: Before installation of a fuel injection valve, be sure the wrench is clean. Put the dust cover on the valve body as soon as possible to prevent dirt entering the fuel passage. Install the fuel injection valve in the following manner:

1. Screw the injection valve body (7) into the fuel injection valve nozzle assembly (3) only finger tight. The threads of the body and nozzle assembly are made to fit loosely. The clearance between the threads provides a passage for fuel to enter the nozzle assembly from the body.
2. Insert the nozzle assembly and valve body as a unit into the pre-combustion chamber opening. Turning the body in a clockwise direction and at the same time pressing down will assure alignment of the serrations.
3. Install a new large seal (5) on the retainer nut. A light coating of lubricant on the seal will permit it to seat properly.
4. Tighten the retainer nut to a torque of 100 to 110 pounds feet to prevent leaks between the nozzle assembly and the nozzle assembly seat.
5. Place a new small seal (6) over the threads on the top of the valve body and on the retainer nut.
6. Connect the fuel injection line and tighten the nuts.

Fuel Injection Pumps

Testing Fuel Injection Pumps: It is not usual for one pump on an engine to require replacement unless all the pumps are worn. Worn fuel injection pumps will result in loss of power and hard starting. When loss of power and hard starting is accompanied with a clear exhaust, good compression and no blow-by gases from the crankcase breather it indicates the fuel injection pumps may be worn. The tools and information required to service and check fuel injection pumps are available at your Caterpillar dealer.

COOLING SYSTEM

Fresh Water System

Coolants: Water used in the cooling system should be soft, or as free as possible from scale forming minerals. Treat the available water with Caterpillar Rust Inhibitor. The use of this rust inhibitor in the cooling system will prevent the formation of rust. It will also retard, and in some cases completely eliminate mineral deposits within the engine. Most commercial anti-freeze solutions contain rust inhibitors, therefore, it is not necessary to use rust inhibitors with those anti-freeze solutions which do contain inhibitors. Your Caterpillar dealer stocks Caterpillar Rust Inhibitor in convenient one quart cans. Directions for its use are printed on each can.

When the temperature is below freezing sufficient anti-freeze should be used in the cooling system to prevent freezing. Various anti-freeze mixtures such as ethylene glycol (Prestone, G.M., Permaguard, Zerex, etc.), denatured ethyl alcohol, methanol (synthetic wood or methyl alcohol), and glycerine are all suitable for use. Alcohol can be used successfully but, because it readily evaporates at the normal operating temperature of the diesel engine the solution should be tested frequently — even daily — and kept up to correct strength. This loss by evaporation is objectionable **but the temperature regulator should not be removed.** Doing so might make the solution run cooler and save the alcohol, but is not desirable for good performance. It is essential, therefore, that the coolant be tested frequently to assure adequate protection.

Filling: Fill the fresh water cooling system by pouring the coolant into the surge tank filler opening.

SURGE TANK
FILLER OPENING



During operation, the coolant will expand due to heat of the engine. For this reason, the expansion tank should not be completely filled when the engine and coolant are cold, as the excess coolant will be wasted through the overflow pipe, when it expands. Actual experience will determine the level of coolant required.

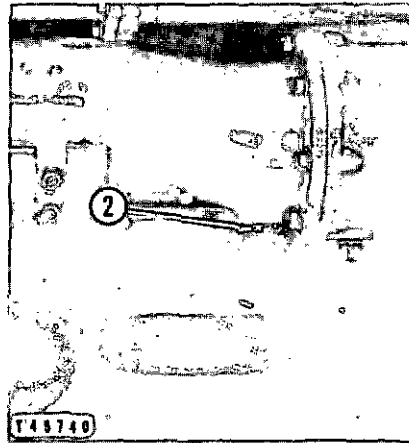
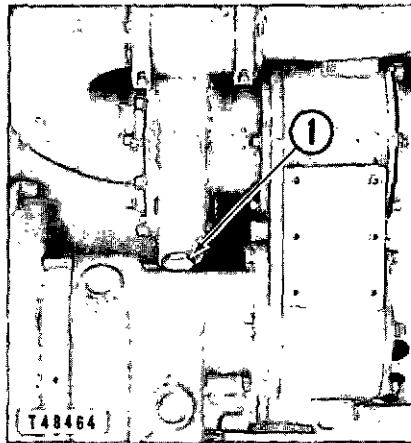

COOLING SYSTEM DRAIN PLUGS

1-Water pump drain plug. 2-Oil cooler drain plug.

Draining: The cooling system can be drained by removing the filler cap for the expansion tank and the drain plug (1) in the bottom of the water pump located on the right side of the engine. Remove the drain plug (2) from the elbow of the oil cooler, remove the drain plug (3) from the left front side and the drain plate (4) from the right rear side of the cylinder block and drain plug (5) from the elbow on the right side of the flywheel housing. When the system is equipped with a heat exchanger, remove the drain plugs at the ends of the core.

If the diesel engine is equipped with a gasoline starting engine, drain later starting engines by removing the cylinder block drain plug (6).

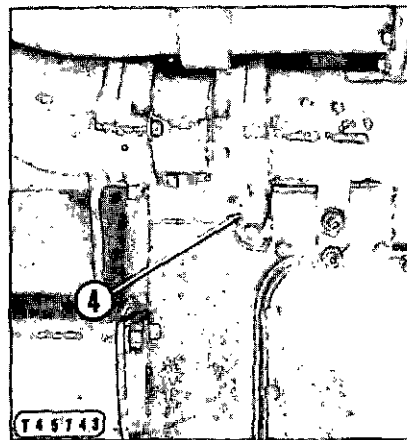

COOLING SYSTEM DRAINS

3-Left front plug on cylinder block. 4-Right rear drain plate on cylinder block.

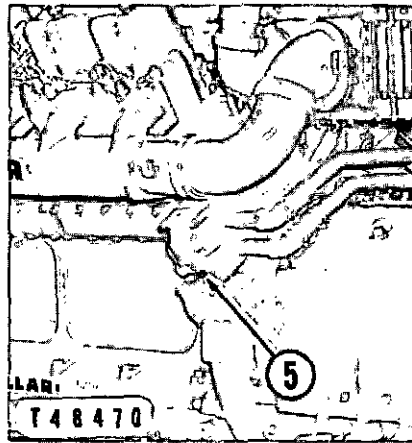

FLYWHEEL HOUSING DRAIN

5-Drain plug in elbow.

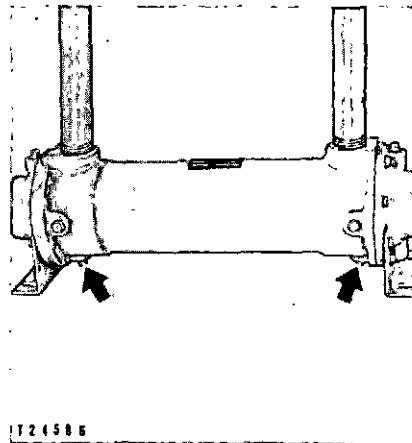

**HEAT EXCHANGER FRESH WATER
DRAIN PLUGS**

Drain earlier starting engines by removing the starting engine water elbow drain plug at the rear of the starting engine cylinder block.

STARTING ENGINE DRAIN PLUG
6-Cylinder block drain plug.

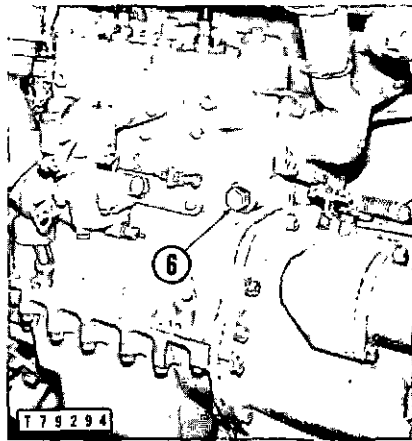

Cleaning the Cooling System: Wash the cooling system periodically. To wash, stop the engine when it is at normal operating temperature and drain as quickly as possible. Flush thoroughly, then fill with a solution of one pound of Oxalic Acid or Sodium Bisulfate per five gallons of water. Run the engine at operating temperature one-half to one hour, then drain and flush until water is clear. Fill with a solution of one-half pound of Sal Soda per ten gallons of water and run the engine ten minutes. Drain, flush and fill with water, adding corrosion inhibitor or the desired amount of anti-freeze.

Cleaning The Oil Cooler: About every 900 service hours, oftener if necessary, the oil cooler should be cleaned to prevent a decrease in cooling efficiency.



CLEANING OIL COOLER
TUBES

To clean the oil cooler, stop the engine, shut off the supply of water to the oil cooler and remove the core from the engine. A rod no larger than 13/64 inch (5.15 mm.) in diameter can be used to push through the tubes of the core to remove accumulations. Reinstall the oil cooler core.

When the end bonnets are removed for cleaning the oil cooler, it will not be necessary to drain the crankcase oil.

Raw Water System

In certain waters, heat exchangers may become less efficient due to formation of scale, foreign materials or accumulated sediment. As such materials accumulate, the fresh water temperature indicator will show a gradual day-to-day increase in reading. Before this reading approaches the boiling point this accumulated material should be removed.

Draining: The raw water cooling system should be drained when the vessel is to be left in storage, at the end of a day's run in freezing temperature, or when the heat exchanger is to be cleaned. To drain the cooling system: First, close the sea valve. Second, remove the water drain plug in the raw water pump. Third, remove the drain plugs (2) from the end bonnets (1) of the heat exchanger. If the raw water piping is equipped with drain plugs, remove the drain plugs.

To prime the raw water pump, remove the filler plug from the tank on top of the pump and fill with water. The pump should be primed when-

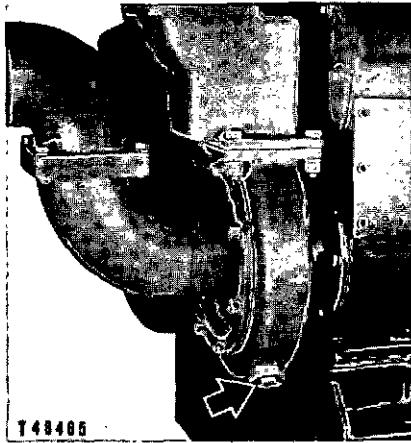

RAW WATER PUMP
DRAIN PLUG

ever the pump has been drained. After priming the pump, install the filler plug.

HEAT EXCHANGER DRAINING
1-End Bonnets. 2-Raw water drain plugs.

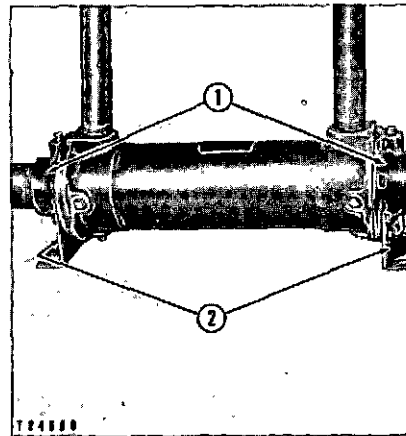

Cleaning the Heat Exchanger: The heat exchanger should be cleaned when the water temperature is continuously 195° F. to 205° F. (91° C. to 96° C.) or more during operation.

Close the sea valve and drain the exchanger of raw water by removing the drain plugs (2). Remove the end bonnets (1) from each end of the exchanger. A rod not larger than 9/32 inch (7.11 mm.) can be used to push through the tubes of the core to remove accumulations. Reinstall the end bonnets and open the sea valve. When the engine is started, any accumulations which were loosened in the tubes will be flushed out of the core.

When the end bonnets are removed to clean the heat exchanger core, it will not be necessary to drain the fresh water system.

Zinc Plugs: Zinc plugs are installed in the raw water system for the purpose of localizing any electrolytic action which may be set up. For easy

identification, all zinc plugs are painted red. Two zinc rods are located in the bottom of the raw water aftercooler, two zinc plugs in the heat exchanger, and two zinc plugs in the ends of the marine gear oil cooler. The plugs should be removed and inspected every 25 service hours and replaced if they are deteriorated. To inspect them close the sea valve, drain the heat exchanger of raw water and remove the zinc plugs. When inspecting the zinc plugs do not be deceived by their outside appearance but tap them lightly with a small hammer. If they crack or crumble, new zinc elements should be installed. If they are not deteriorated and merely appear to be corroded they may be cleaned by scraping away the corrosion.

When the zinc plugs are removed for inspection, it will not be necessary to drain the fresh water system.

DIESEL ENGINE VALVE CLEARANCE ADJUSTMENT

Check the valve clearance every 1000 service hours. The compression release lever must be in the run position and the engine stopped to check or adjust valve clearance and compression release clearance. Rotate the engine crankshaft in the direction of engine rotation until the pushrod is at the lowest point and the valve to be adjusted is closed.

To Adjust:

1. Loosen valve adjusting screw locknut (2).
2. Turn adjusting screw (3) to allow a thickness gauge of the correct thickness to be passed between end of the valve and valve rocker

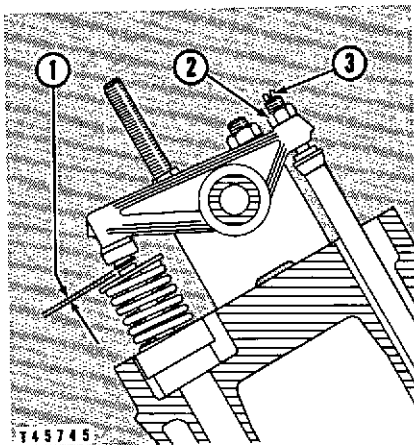

VALVE CLEARANCE ADJUSTMENT
1-Valve clearance, inlet valve .015 inch (0.38 mm.), exhaust valve .035 inch (0.89 mm.). 2-Locknut. 3-Adjusting screw.

at (1). Valve clearance on a cold engine should be .015 inch (0.38 mm.) for inlet valves and .035 inch (0.89 mm.) for exhaust valves.

3. Tighten locknut (2) and recheck the clearance.

Compression Release Adjustment: Check the compression release clearance at (1) each time inlet valve clearances are changed or checked, the compression release lever must be in the run position. To adjust proceed as follows:

1. Loosen locknut (3).
2. Turn rod end (2) to allow a thickness gauge of the correct thickness to be passed between rod end (2) and the tail of the valve rocker at (1). The clearance should be .025 to .030 inch (0.64 to 0.76 mm.).
3. Tighten locknut (3) and recheck the clearance.

COMPRESSION RELEASE ADJUSTMENT

1-Compression release clearance .025 to .030 inch (0.64 to 0.76 mm.). 2-Rod end. 3-Locknut.

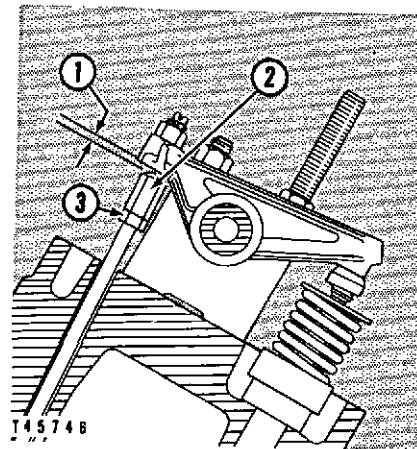

Check Valve Rotators: Valve rotators are located under each valve spring, in the diesel engine cylinder head. Check the valve rotators with the engine running, after the valve clearance adjustment check has been made, to see if the valves rotate. The rotating of valves decreases carbon build up and uneven wear, thereby increasing the life of the valves. To check, draw a pencil line on the valve spring retainer and observe the valve rotation. If the valves do not turn the valve rotators should be replaced. See your Caterpillar dealer.

Attachment Instructions

Marine Gear information is covered in the **Operation and Maintenance Instruction Book for the Marine Gear**

Attachments are available from your Caterpillar dealer. Many of these attachments will add to operator comfort and convenience as well as increase the usefulness of your engine.

GASOLINE STARTING ENGINE FUEL SYSTEM

Keeping the starting engine fuel tank filled will prevent condensation in the tank. Periodically drain any water which may have accumulated in the starting engine fuel tank sediment bowl.

Carburetor Adjustments: To obtain an approximate carburetor adjustment, turn the adjusting screws gently against their seats. Then back off the high speed mixture adjusting screw (3) one turn from the closed position and the low idle mixture adjusting screw (1) one-half turn from the closed position.

A more accurate adjustment can be obtained while the engine is running at full governed speed by turning the high speed mixture adjusting screw out to make the mixture richer or in to make it leaner. Adjust this screw to a point that will give the greatest amount of power with a clear exhaust. Turn the low idle mixture adjusting screw (1) until the engine will idle regularly at slow speed without emitting black smoke from the exhaust. Turn this screw out to make the mixture leaner or in to make it richer. Turn the low idle speed control screw (2) to the left (out) to decrease low idle speed or to the right (in) to increase the speed.

CARBURETOR ADJUSTMENT

- 1-Low idle mixture adjusting screw.
- 2-Low idle speed control screw.
- 3-High speed mixture adjusting screw.

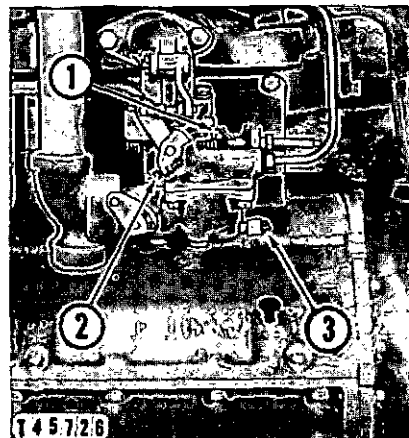

Sediment Bowl Filter: The sediment bowl (1) collects water and sediment that may be in the fuel. To remove the collected water and sediment, close the valve (2) and remove the bowl by unscrewing the nut (4) that clamps it to the body of the valve. Unscrew the edge-type filter element (5) and shake it in kerosene or some nonflammable cleaning fluid.

STARTING ENGINE SEDIMENT BOWL FILTER

1-Sediment bowl. 2-Valve. 3-Gasket.
4-Nut. 5-Edge type filter element.

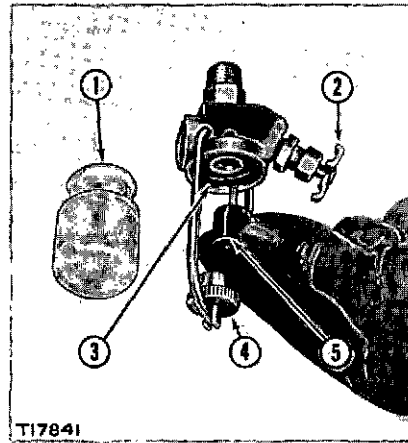

When the bowl is replaced see that the gasket (3) is clean, is in the correct position, and is not broken.

STARTING ENGINE DRY TYPE AIR CLEANER

Every 250 service hours clean the filter element. The element may have to be cleaned more often under dusty conditions or whenever hard starting and/or loss of speed and power is observed. To service the element proceed as follows:

1. Unscrew the wing nuts (1) which retain the assembly.
2. Remove the air cleaner cover plate (2) and the filter element (3).
3. Clean the element by directing clean dry air under pressure (not to exceed 100 PSI) against the inside of the element forcing air through the element to the outside. Do not let dust collect on the inside of the element.
4. While the filter is removed inspect and clean all parts of the cleaner before assembly.

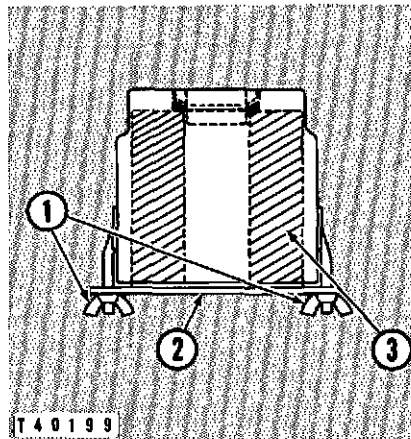

AIR CLEANER ASSEMBLY

1-Wing nuts. 2-Cover plate.
3-Filter element.

If the element is damaged or if after cleaning, the engine is hard to start and/or loss of power has not been corrected, install a new Caterpillar element.

Replace the filter element at least once a year.

SAFETY DRIP COLLECTOR

Gasoline starting engines are equipped with a safety drip collector. It is located below the carburetor. The safety drip collector is connected to the starting engine carburetor so the collector can catch any excess fuel from the carburetor, thus the hazard from gasoline fumes is cut to a minimum. Remove bowl (1) and wash occasionally.

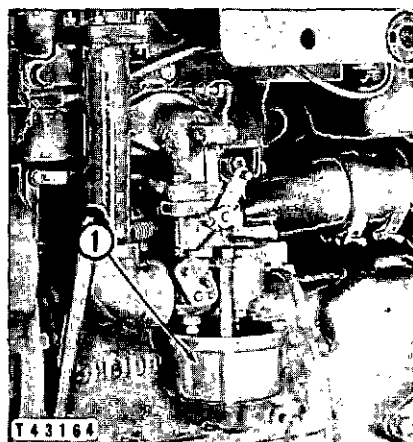

SAFETY DRIP COLLECTOR
1-Bowl.

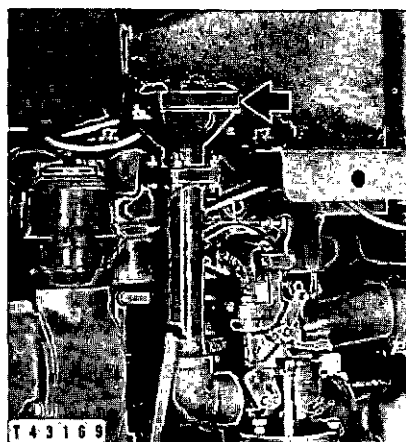

FLAME ARRESTER

STARTING ENGINE FLAME ARRESTER

The starting engine has a flame arrester on the inlet manifold to reduce fire hazard if the starting engine back-fires.

Remove the flame arrester occasionally to clean the small openings by removing the fastening screws. Use a wire brush to clean out any dirt or corrosion, then wash it with kerosene or some non-inflammable cleaning fluid. Replace the flame arrester and tighten the screws.

STARTING ENGINE VALVE CLEARANCE ADJUSTMENT

The valve clearance adjustment should be checked every 2000 service hours. To check the adjustment remove the carburetor and valve cover. The valve clearance check or adjustment should be made when the engine is hot. To check, crank the engine until the valve closes and the valve lifter is at its lowest position.

To Adjust: Turn the adjusting screw until there is .008 inch (0.2 mm.) clearance at (2) between the adjusting screw and the end of the valve stem. Check this clearance with a thickness gauge (1).

STARTING ENGINE VALVE CLEARANCE ADJUSTMENT

1-Thickness gauge. 2-There should be .008 inch (0.2 mm.) clearance at this point.

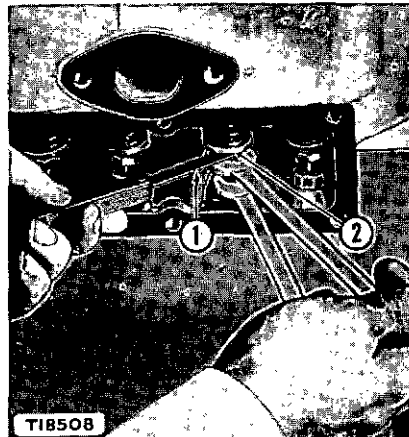

SPARK PLUG ADJUSTMENT

The spark plugs should be examined every 1000 service hours. The gap should be kept at approximately .030 inch (.76 mm.). Measure this gap with a thickness gauge. To adjust the gap, bend the outer electrode.

STARTING ENGINE MAGNETO

Do Not Lubricate The Magneto At Any Point: The bearings are packed with a ball and roller bearing grease when assembled, and this should be replaced only when the magneto is taken to your Caterpillar dealer for checking or reconditioning.

Checking Contact Point Opening: Every 1000 service hours check the contact point opening.

To check, first remove the distributor cap. Care should be taken in removing the cap not to damage the gasket. Clean any carbon dust from

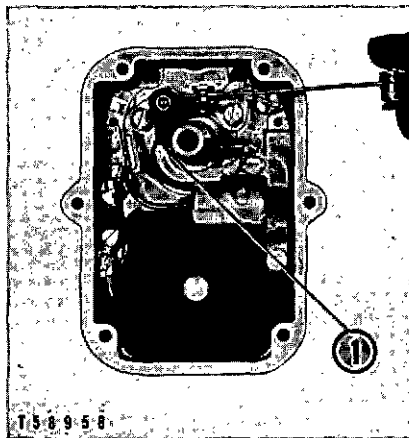

CHECKING CONTACT POINT OPENING

1-Contact point bumper block on one of the highest elevations of the cam.

inside the cap and any carbon track from the rotor by using a soft cloth dampened with a nonflammable cleaning fluid. Remove the distributor rotor, then turn the engine until the contact point bumper block (1) is on one of the highest elevations of the cam. Check the clearance with a thickness gauge between the contact point as illustrated. This clearance should be .015 inch (.38 mm.).

Adjusting Contact Point Opening: Loosen the screws (2) which hold the adjustable contact point bracket and move the bracket by inserting a screwdriver in the slot (3) and turn either clockwise or counterclockwise until the correct point opening is obtained. Then tighten the fastening screws and recheck the adjustment.

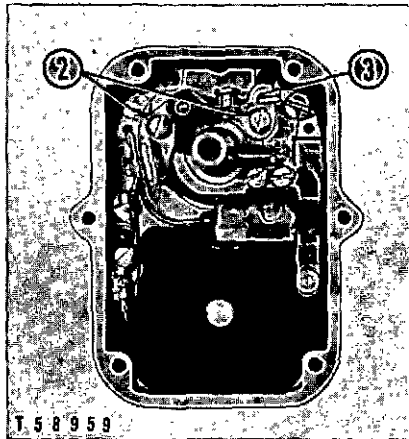

**ADJUSTING CONTACT POINT
OPENING**

2-Bracket fastening screws.
3-Slot.

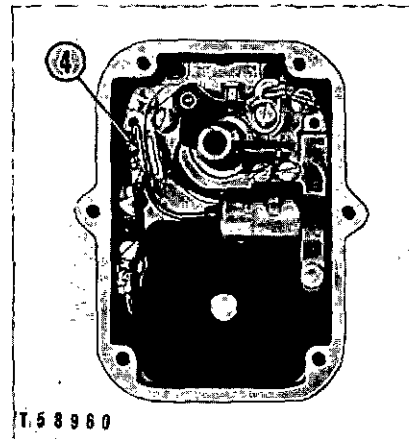

REMOVING CONTACT POINTS

4-Spring clamp screw.

To Remove The Contact Points: To remove the contact points, remove the spring clamp screw (4). Remove the two screws (2) used in adjusting the contact point opening.

Testing: A magneto may be tested when coupled to the engine by turning the switch, ON, removing the cable from a spark plug and holding the terminal $\frac{1}{8}$ inch (3.17 mm.) away from the metal base of the plug while cranking the engine. If no spark passes from the terminal to the metal base, disconnect the magneto switch wire from the terminal on the magneto and test again. If a spark now occurs with the switch wire removed, the wire from the magneto to the switch has become grounded or the switch requires replacement. If, with the switch wire off, the magneto still does not fire, remove the magneto as instructed in the next paragraph and take it to your Caterpillar dealer for testing.

To Remove The Magneto For Testing: Disconnect the cables from the magneto. Remove the two bolts that hold the magneto to the timing gear cover and lift off the magneto.

To Time The Magneto To The Engine: To time the magneto to the engine, proceed as follows:

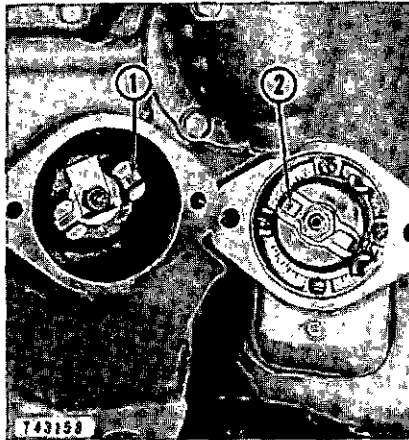

TIMING MARKS

1-Mark "X" on magneto drive. 2-Mark "X" on the impulse coupling tang.

1. Locate the "X" mark (1) on the starting engine magneto drive.
2. Turn the magneto impulse coupling until the "X" mark (2) on the tang is in such a position as to line up with the mark on the magneto drive.
3. Install the magneto with the "X" marks together and tighten the bolts.

To Reinstall Magneto Wires: To reconnect the magneto wires proceed as follows:

1. Place the spark plug wire from number 1 cylinder (the cylinder farthest away from the flywheel) into the number 1 wire receptacle of the magneto cap.
2. Install the other spark plug wire.
3. Reconnect ground wire.

STARTING ENGINE CLUTCH

To Test The Adjustment: Pull the clutch lever forward to the engaged position. The lever should go into position with a distinct snap, and should require a reasonably hard pull.

To Adjust: Remove the plate from the rear of the clutch compartment. Turn the spider (3) with a screwdriver until the lock pin (2) is accessible. Pull the lock pin out and turn the collar (1) to the right until the lock pin drops into the next hole.

Test the adjustment by engaging the clutch. If one hole gives a slightly loose adjustment and the next gives too tight an adjustment, use the looser adjustment.

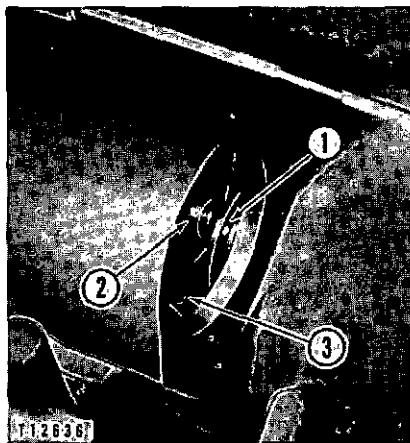

STARTING ENGINE CLUTCH ADJUSTMENT

1-Collar. 2-Lock pin. 3-Spider.

AIR STARTING MOTOR OILER

The air starting motor oiler automatically meters oil into the air system in the form of a fine fog to lubricate the air motor vanes when the air control valve is opened. An air director tube (venturi tube) located in the air passage of the oiler body (3) delivers air pressure above the oil in bowl (4). Oil flows from the bowl through a tube and drilled passage in oiler body (3) into the air stream and then to the motor.

The oiler is designed to operate satisfactorily in a perpendicular position as long as the bowl is kept filled to the proper level. The oiler should be regulated to meter about four drops of oil per minute to the air stream.

Oil drips into the air stream only when air passes through the oil to the air motor.

To regulate the drops of oil from the oiler.

1. Crank the engine with the compression release lever in the start position and the governor control in the shut-off position.
2. Turn valve needle (1) counterclockwise to increase or clockwise to decrease the amount of oil.

AIR STARTING MOTOR OILER

1-Valve needle. 2-Top plug. 3-Oiler body. 4-Bowl. 5-Sight feed glass.

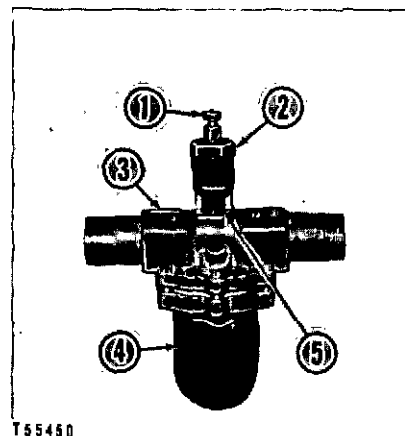

I 55450

3. While cranking the engine watch the sight feed glass (5) to see the oil dripping.

If the oiler becomes clogged or cannot be adjusted to deliver the proper quantity of oil, remove top plug (2) and valve needle (1) from the plug. Lift the oil drip gland out of the body and wash it in kerosene or some nonflammable cleaning fluid. Be sure the oil passage is open in both the body and drip gland before reinstalling the top plug. If it is suspected that dirt or sludge has accumulated in bowl (4) remove the bowl and clean it thoroughly in kerosene or some nonflammable cleaning fluid and blow out the passages in the body with compressed air.

When the jar on the air silencer becomes more than half filled with oil, remove the oiler body filler plug and fill the oiler with clean oil. Dispose of the oil in the air silencer jar and reinstall the jar.

ELECTRICAL SYSTEM

12 and 32 Volt Systems

The basic electrical system is composed of the following:

1. Battery.
2. Wiring.
3. Generator or alternator.
4. Generator regulator or alternator regulator.

These components functioning together produce and store the electricity necessary for operating the electrical equipment on the machine and each is dependent upon the others for satisfactory operation. In the event of failure or improper operation it is essential to check the entire electrical system, as a defect in one component can cause damage to another.

The topics which follows describe the proper maintenance of the components to assure satisfactory operation of the electrical system.

Battery

Every 50 service hours, or more often when continuous operation without the use of the battery is encountered, the following attention should be given to the battery to insure high efficiency and maximum operating life.

Testing: The battery should be tested with a hydrometer and kept to a specific gravity of 1.250 or above. Always test a battery for state of charge before adding water. A dangerously low point of charge is indicated by a hydrometer reading of 1.150 which will permit the battery to freeze at temperatures only a few degrees below the freezing point of water. A specific gravity of 1.250 will permit the battery to withstand temperatures as low as -60°F . without freezing.

When the specific gravity difference between cells of the battery exceeds .025, it indicates the battery may soon need replacing.

Water Addition: The water level should be maintained $\frac{3}{8}$ inch (9.5 mm.) above the separators or insulators by addition of distilled water or "approved water" (water free from impurities by analysis). Do not overfill or underfill the cells of the battery as either has a detrimental effect on battery life.

Charging: The charging rate is correct when the battery maintains a minimum specific gravity of 1.250 and does not require the addition of more than 1 ounce of water per cell per week or 50 service hours.

When there is evidence of either overcharging or undercharging, the cause should be found and corrected as soon as possible to protect the service life of the battery. See the topic, GENERATOR, GENERATOR REGULATOR and WIRING.

Cleanliness: Keep the top of the battery clean and dry to prevent current losses and keep the terminals clean and tight. To clean corrosion from the battery terminals, scrub them with a weak solution of bicarbonate of soda (baking soda) and water. Dry the battery thoroughly, then coat the terminals with lubricant to prevent corrosion. Keep the battery securely fastened in its compartment at all times.

Installation: When installing a battery in its compartment fasten it securely and be sure to attach the cables to the correct battery terminals. Incorrect grounding of the battery will reverse the polarity of the electrical system and cause damage to the generator regulator. See the topics GENERATOR REGULATOR, ALTERNATOR REGULATOR and ALTERNATOR.

Wiring

The wiring forms an important part of the electrical system and care should be used to protect it from damage. When the electrical system is being serviced, check the wiring for loose or dirty connections, worn insulation or broken wires. Inspect the battery terminals and cables. Poor connections or wiring can cause trouble or damage in other parts of the electrical system. See the topics, BATTERY, GENERATOR, GENERATOR REGULATOR, ALTERNATOR and ALTERNATOR REGULATOR.

Wiring Diagrams: The diagrams are furnished so that when it becomes necessary to disturb the electrical equipment for purpose of reconditioning or parts replacement, reassembling may be accomplished without difficulty.

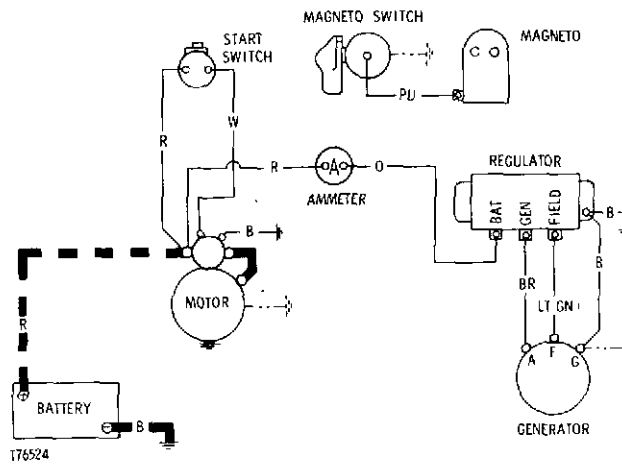

WIRING DIAGRAM FOR ENGINES EQUIPPED WITH A 12 VOLT 35 AMPERE ELECTRIC SYSTEM FOR STARTING ENGINE

COLOR CODE	
B	BLACK
W	WHITE
R	RED
O	ORANGE
BR	BROWN
LT GN	LIGHT GREEN
PU	PURPLE
W/B	WHITE WITH BLACK STRIPE

CABLE SIZE	MAXIMUM RECOMMENDED TOTAL BATTERY CABLE LENGTH	
	12 VOLT	24-32 VOLT
0	4.0 FEET	15.0 FEET
00	5.0 FEET	18.0 FEET
000	6.0 FEET	21.0 FEET
0000	7.5 FEET	27.0 FEET

WIRE AND CABLE SHOWN DOTTED, CUSTOMER FURNISHED.

IF ALTERNATOR RATED OUTPUT IS GREATER THAN 45 AMPERES, THE WIRES MARKED (X) ARE TO BE WIRED WITH THE HEAVY GAUGE WIRE SUPPLIED IN THE WIRING KIT GROUP.

T77679

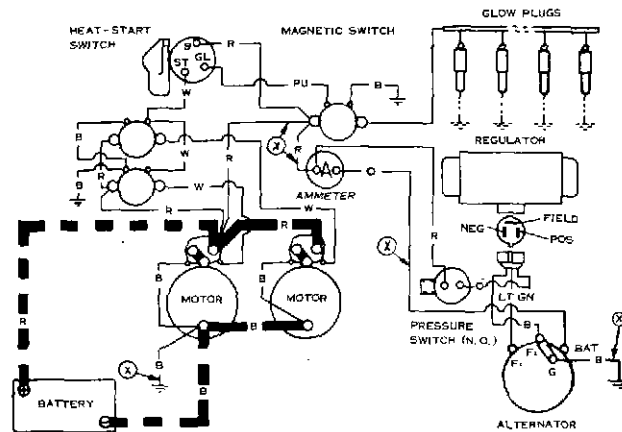

T76541

(Later)

WIRING DIAGRAM FOR ENGINES EQUIPPED WITH EITHER A 30 VOLT 60 AMPERE OR A 32 VOLT 60 AMPERE CHARGING ALTERNATOR WITH GLOW PLUGS AND ELECTRIC STARTING

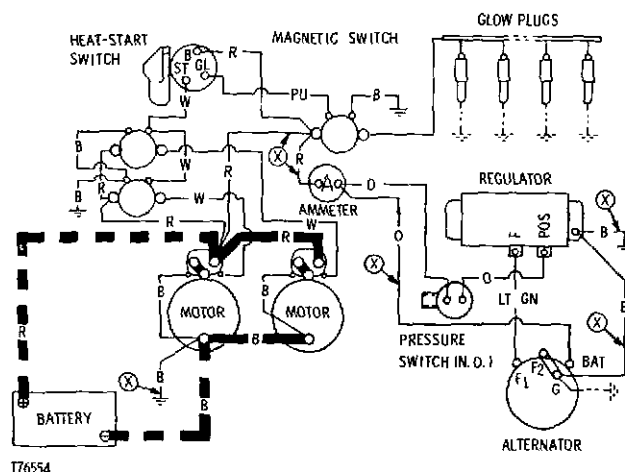

(Earlier)

WIRING DIAGRAM FOR ENGINES EQUIPPED WITH EITHER A 30 VOLT
60 AMPERE OR A 32 VOLT 60 AMPERE CHARGING ALTERNATOR
WITH GLOW PLUGS AND ELECTRIC STARTING

12 Volt System

Generator

Never operate a generator with an open circuit between it and the battery.

General Reconditioning: Every 2000 service hours, the generator should be removed and the commutator and brushes checked for glaze or darkening. At the same time the generator should be completely disassembled, washed and have all worn parts replaced. It is suggested that this cleaning and reconditioning be entrusted to your Caterpillar dealer.

Generator Removal: Remove all wires from the generator and tag them so that they may be connected correctly when the generator is reinstalled. Remove the bolts or stud nuts that hold the generator in position and lift off the generator.

Generator Installation: Whenever a generator is installed, or reconnected to the generator regulator, it must be polarized **before** starting the engine. Follow the instructions carefully to prevent damage to the generator, generator regulator or both, due to incorrect polarizing.

1. Place the generator in position and install the bolts or stud nuts.
2. Connect all wires to the generator, regulator and battery. See the topic, WIRING.
3. Polarize the generator.

Polarizing Generators: Turn the disconnect switch ON, if engine is so equipped. Connect a jumper wire momentarily between the regulator

terminals marked BAT and GEN. Make sure all connections are clean and tight. See the topics, BATTERY, GENERATOR REGULATOR and WIRING.

Generator Regulator

The generator regulator is adjusted at the factory for average operating conditions. The regulator may have to be readjusted to provide the proper charging rate for the particular operating conditions of the machine. In case of failure of either the regulator or generator, both units should be taken to your Caterpillar dealer, where the output of the generator can be checked and the regulator adjusted accordingly.

Charging Rate: The normal function of the generator regulator is to adjust the generator charging rate by sensing the state of charge in the battery. As the battery becomes fully charged, the charging rate should drop until the ammeter indicates a rate only perceptibly above zero.

When improper charging of the battery is encountered, the entire electrical system should be carefully checked. Loose or dirty connections, worn or broken wires, or a faulty generator can prevent a good regulator from functioning properly. See the topics, BATTERY, GENERATOR, and WIRING.

Polarity: Electrical systems may have either the positive or negative terminals grounded. When connecting the battery, be sure to ground the same battery terminal that was originally grounded. On new installations or where the battery grounding is questioned, check the generator regulator to determine the polarity of the system. The battery must be grounded as indicated on the regulator or damage will result.

The voltage and polarity of the electrical system are marked either on the cover or on the base of the regulator near a mounting hole. These marks may appear in any of the following forms: "12 VOLTS - NEGATIVE GROUND," "12V - NEG." or "12 V N." Similar marks are used for other voltages and for POSITIVE ground systems.

30 Volt and 32 Volt Systems

Charging Alternator

Never operate a charging alternator with an open circuit between it and the battery.

The 32 volt self-rectifying charging alternator is designed to give long service periods with a minimum amount of maintenance. The grease reservoirs, for each of the two ball bearings on which the rotor is mounted, eliminate the need for frequent bearing lubrication. Six rectifier diodes change A. C. power to D. C. power.

Alternator Removal: Remove all wires from the alternator and tag them so that they may be connected correctly when the alternator is installed. Remove the bolts or stud nuts that hold the alternator in position and lift off the alternator.

Charging Alternator Installation: Remove the power supply to the electrical system by disconnecting the positive and negative battery cables. Install the alternator. Connect the tagged wires to the correct alternator terminals and the battery cables to their respective battery terminals.

CAUTION

Do not attempt to polarize the alternator. If an accidental connection is made between the "BAT" terminal (3) and either of the "F" terminals, (1) or (2), on the alternator, the rectifiers in the alternator and the transistors in the regulators will be damaged.

CHARGING ALTERNATOR

1-"F1" terminal. 2-"F2" terminal.
3-"BAT" terminal.

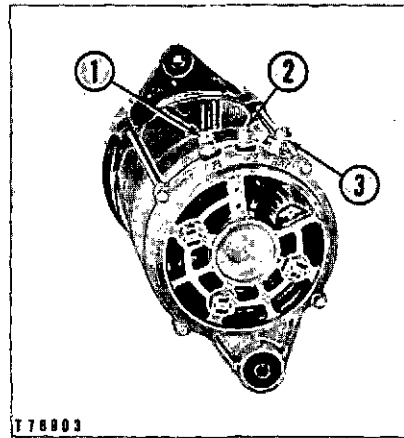

Do not make or break any alternator connections with the alternator operating. Making or breaking an alternator connection with a heavy load on the circuit could result in damage to the voltage regulator. Never operate the alternator without the battery connected in the circuit. When recharging the battery from an external source disconnect the battery from the alternator to prevent damage to the alternator rectifiers. Before using booster cables to start the engine, be sure of the lead polarity and connect the batteries correctly. To connect the booster cables incorrectly for even an instant will destroy the alternator's rectifying diodes. Do not operate the alternator simultaneously with a DC generator on a common battery circuit.

Charging Alternator Belt Adjustment

The generator belt should be checked every 250 service hours for proper adjustment. Correct adjustment exists when the belt can be pushed downward 9/16 to 13/16 inch (1.4 to 2.0 cm.) with approximately 25 pounds pressure exerted midway between the pulleys.

Adjusting Belt: Loosen the bolt (1) and hinge bolts (2). Move the generator out until the belt can be pushed downward $9/16$ to $13/16$ inch (1.4 to 2.0 cm.) with a force of approximately 25 pounds exerted midway between the pulleys.



ALTERNATOR BELT ADJUSTMENT

1-Bolt. 2-Hinge bolts.



When a belt (or belts) need replacing, a matched set which is available from your Caterpillar dealer should be used. Always install a matched set — never only one.

Alternator Regulator

The alternator regulator should be mounted where the ambient temperatures will not exceed 170° F. in moving air, or 140° F. in still air.

The alternator regulator senses the charge condition of the battery as well as electrical system power demand, and controls the alternator output accordingly. As the battery becomes fully charged, the charging rate should drop until the ammeter indicates a rate only perceptibly above zero.

Charging Rate: The alternator regulator is adjusted at the factory for average operating conditions. This voltage setting should maintain the batteries in a fully charged condition and not require more than 1 ounce of water be added per cell per 50 service hours. The regulator may require adjusting to provide the proper charging rate for the particular ambient temperature in which the engine is being operated.

Overcharging of the battery will usually be indicated by the need of frequent addition of water to the battery cells. See the subject of water addition under the topic BATTERY. If the battery is continually in a low state of charge, first check the entire electrical system and battery for loose or dirty connections, worn or broken wires, or corroded terminals. When either undercharging or overcharging occurs, the alternator and regulator should be taken to your Caterpillar dealer where the alternator

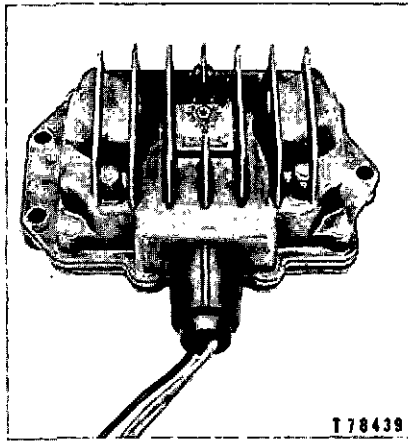

**FULL TRANSISTOR ALTERNATOR
REGULATOR**

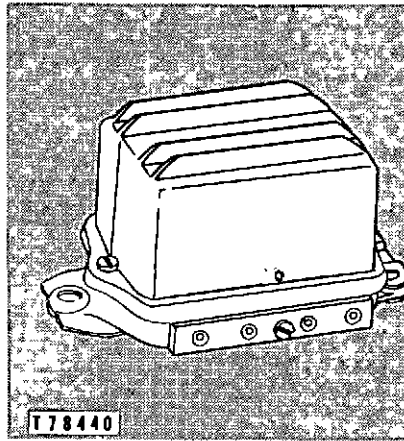

**TRANSISTOR TYPE ALTERNATOR
REGULATOR**

output can be checked and the charging rate changed to properly charge the battery.

ELECTRIC STARTER

(12 and 32 volt systems)

No periodic service is indicated for the electric starter brushes between general reconditioning periods. The brushes should only be inspected after removal of the starter from the engine and removal of the commutator end bearing frame. The 32 volt electric starter commutator end and drive end bearings are equipped with wicks for lubrication purposes. The wicks should be saturated with oil whenever the electric starter is removed or disassembled.

General Reconditioning: Approximately every 4,000 service hours, the starter should be removed so that it may be completely disassembled, washed and have all parts replaced that show evidence of being unsatisfactory for reason of wear. Do not use a degreaser or high temperature cleaning method when cleaning parts of the starter or overrunning clutch. If the overrunning clutch turns roughly when rotated in the overrunning direction or slips in the cranking direction, after the clutch has been washed, it must be replaced with a new clutch. It is suggested that cleaning and reconditioning be entrusted to your Caterpillar dealer.

GLOW PLUGS

Maintenance: If it is suspected that the glow plugs are not correctly assisting in starting, the system should be checked for defective glow plugs with the engine stopped. The ammeter should be observed when making this check to show that each glow plug uses approximately 4 amperes.

An ammeter of sufficient capacity should be connected between the glow plug side of the magnetic switch and the lead wire to the glow plug harness. Then move the HEAT and START switch to the HEAT position. A reading on the ammeter should be approximately equal to the number of glow plugs in the system multiplied by 4. Any reading that varies appreciably from this may indicate one or more defective glow plugs.

To locate the defective glow plug or plugs, check each glow plug separately by removing the leads from the glow plugs, one at a time, with the HEAT and START switch in the HEAT position. **Reconnect the lead to the plug before removing the lead from the next glow plug to be checked.** When a lead is removed from a glow plug, with no variation shown on the ammeter, it can be assumed that the plug is defective and should be replaced.



GLOW PLUG

To remove a defective glow plug, disconnect the lead from the glow plug; unscrew the glow plug from the precombustion chamber.

Apply anti-seizure compound to the thread of a new glow plug and install the glow plug into the precombustion chamber, tightening it to a torque of from 10 to 12 pounds feet.

The glow plug should first be removed before removing and replacing a fuel injection valve to eliminate the possibility of damaging the glow plug.

SAFETY ALARM SWITCHES

The engine may be equipped with a water temperature alarm switch and an oil pressure alarm switch. A signal light, horn or bell or a combination can be placed in the circuit so that the operator will be warned in case the water temperature or oil pressure reach dangerous levels. The operator can then shutdown the engine and correct the difficulty. For further information see your Caterpillar dealer.

TYPICAL SAFETY ALARM CIRCUIT

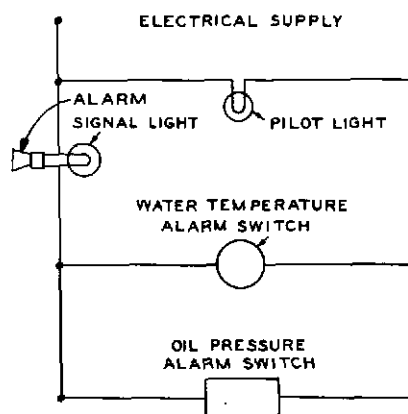

T17569

Water Temperature Alarm Switch

The water temperature alarm switch is located in the water temperature regulator housing at the front of the engine if not equipped with safety shut-off arrangement. The rise in engine water temperature causes the metallic coil to expand, operating a single throw, snap-acting, magnetic switch. This switch is open during cold and normal water temperature ranges. When excessive temperatures are reached the switch is closed thus sounding the alarm.

The switch is designed to be installed in series with an alarm switch or relay switch having a rating not to exceed the maximum as follows:

1. In circuits of single phase, 115 volts alternating current, connected directly to the alarm, 5 amperes.
2. In circuits of single phase, 230 volts alternating current, connected directly to the relay, 2.5 amperes.
3. In circuits up to 600 volts alternating current, where another switch (relay) is operated, 1 ampere.
4. In circuits of 125 volts, where a direct current relay is employed, .5 ampere.
5. In circuits of 250 volts, where a direct current relay is employed, .25 ampere.

Oil Pressure Alarm Switch

The oil pressure alarm switch is mounted at the front of the engine on a bracket fastened to the accessory drive housing. When the engine oil pressure drops to the danger point a diaphragm actuates the contact points thus closing the circuit to sound the alarm.

The switch is designed to be installed in series with alarm or relay switch having a rating not to exceed the maximum as follows:

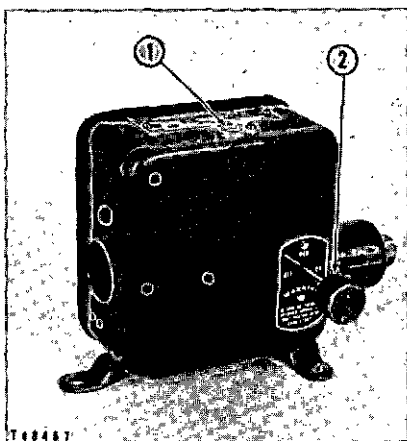

**OIL PRESSURE
ALARM SWITCH**

1—Adjusting screw. 2—Control knob.

- 1—Circuits of 115 volts, alternating current, 15 amperes.
- 2—Circuits of 230 volts, alternating current, 15 amperes.
- 3—Circuits of 6 to 32 volts, direct current, 15 amperes.
- 4—Circuits of 115 volts, direct current, 6.5 amperes.
- 5—Circuits of 230 volts, direct current, 3.3 amperes.

Oil Pressure Alarm Switch Operation: When the engine is stopped the oil pressure drops closing the switch and causing the alarm to sound. A control knob (2) is provided to stop the alarm when the arrow on the knob is turned to the START or OFF position. When the engine starts pressure builds up and the knob automatically flips to RUN position. Watch to be sure it does change after each start, as this indicates that alarm contactor is ready to function in case of no oil pressure.

Adjustments: This control was originally set at factory, but if it is necessary to change factory setting, proceed as follows:

- 1—Set manual control knob with arrow pointing to RUN. This places the control in the running position.
- 2—Decrease all tension on main spring by turning adjusting screw (1) to left (counterclockwise).
- 3—Connect pressure bellows to air pressure line and increase the air pressure to a little more than 12 psi. Decrease the air pressure to 8 psi, the pressure at which the contacts should close, sounding the alarm.
- 4—Hold pressure on bellows constant and turn adjusting screw to right (clockwise) just to point where contacts close.

SAFETY SHUT-OFF CONTROL

The safety shut-off control is a safety device which is mechanically connected to the diesel engine and will protect the engine from damage

SAFETY SHUT-OFF CONTROL

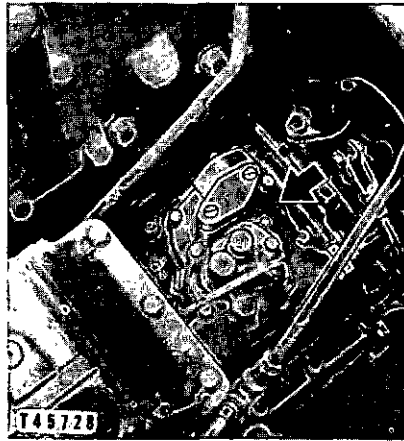

by automatically stopping the engine if either the lubricating oil pressure drops and stays below safe limits or if the speed of the engine becomes excessive.

A high water temperature safety shut-off attachment is available from your Caterpillar dealer. The high water temperature shut-off attachment is connected with the safety shut-off control and will stop the engine if high water temperatures in the engine cooling system occur.

In the event that the safety shut-off control has stopped the engine because of engine overspeed, low lubricating oil pressure or high water temperatures, the reason for the engine shutdown must be determined and corrected. After the reason for the engine shutdown has been determined and corrected the safety shut-off control must be reset before the engine can be started. See the topic **RESETTING THE SAFETY SHUT-OFF CONTROL**.

Operation: The safety shut-off control is geared to the diesel engine. The overspeed carrier (3) and worm shaft (1) are always turning whenever the diesel engine crankshaft is rotating. The latch (4), when latched as shown, holds the spring loaded rod (5) away from the diesel engine fuel injection pump rack. Slide (2) has a rack that can mesh with worm shaft (1). Diesel engine lubricating oil pressure holds the slide away from the worm shaft. If the lubricating oil pressure drops and stays below safe operating limits, slide (2) meshes with and moves along worm shaft (1). In seven seconds, at engine operating speed, the slide contacts latch (4) and unlatches rod (5). The spring loaded rod when unlatched, moves and holds the fuel injection pump rack in the shut-off position thus stopping the diesel engine. If the diesel engine overspeeds, a spring controlled weight in overspeed carrier (3) moves out by centrifugal force, strikes latch (4) and unlatches rod (5) stopping the diesel engine as previously explained.

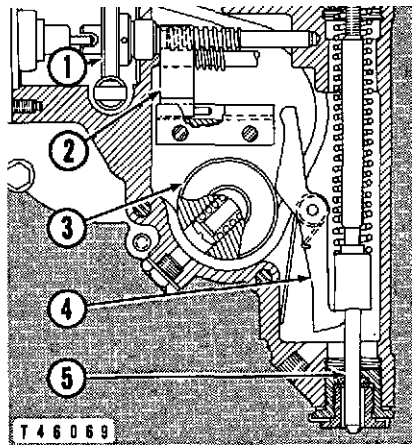

SAFETY SHUT-OFF CONTROL

1-Worm shaft. 2-Slide. 3-Overspeed carrier. 4-Latch. 5-Rod.

The safety shut-off control must be reset by pulling on the safety shut-off control reset knob before the diesel engine fuel injection pump rack can be moved from the shut-off position.

The diesel engine can be stopped by pushing the manual shut-off button (1). The shut-off button, when pushed, simulates an overspeed engine condition by mechanically moving the spring controlled weight far enough out of the overspeed carrier until the weight strikes the latch and releases the spring loaded rod. The rod, when released moves and holds the fuel injection pump rack in the shut-off position, thus stopping the engine.

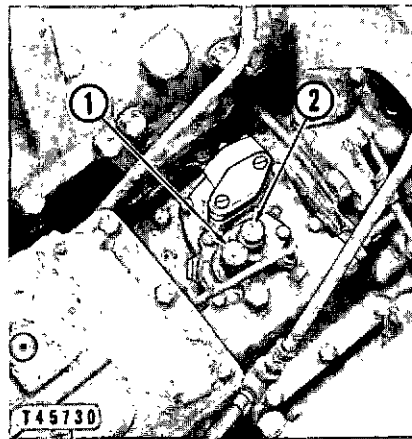

SAFETY SHUT-OFF CONTROL

1-Manual shut-off button. 2-Reset button.

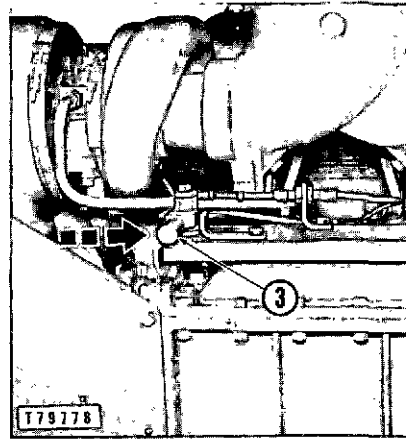

SAFETY SHUT-OFF CONTROL

3-Reset lever.

Resetting the Safety Shut-off Control: After the safety shut-off control has stopped the engine, the shut-off control must be reset before the diesel engine fuel injection pump rack can be moved from the shut-off

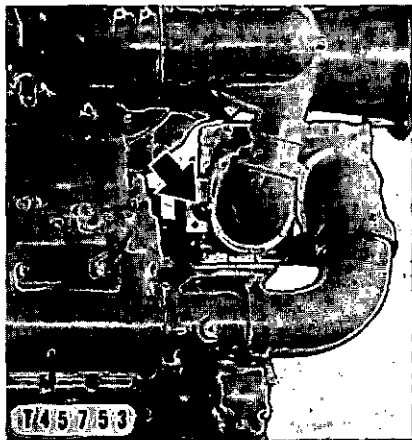

**SAFETY SHUT-OFF CONTROL
RESET KNOB**

position and the engine started. First, push down on reset button (2). Then, on later engines move reset lever (3) to the right until the safety mechanism latches. On earlier engines pull out the safety shut-off control reset knob until the safety mechanism latches.

CAUTION

After starting, if sufficient oil pressure has not developed, the engine will shut off again after running approximately seven seconds at operating speed. Therefore, **check the oil pressure immediately** after starting by observing the oil pressure gauge indicator to see that it is in the operating range.

Safety Shut-off Control Adjustment: The only adjustment is for maximum RPM shut-off. Whenever the control has been disassembled or the adjustment disturbed, adjust the maximum RPM shut-off as follows:

1. Remove the plug (1) from the bottom of the shut-off control housing.

SAFETY SHUT-OFF CONTROL
1-Plug. 2-Weight adjusting screw.

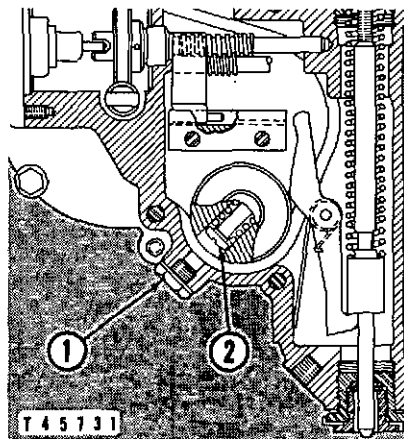

2. Turn the weight adjusting screw (2) in (clockwise) to raise and out (counterclockwise) to lower the maximum RPM shut-off. One complete turn will change the maximum limit 45 to 60 RPM.

NOTE

It may be necessary to rotate the engine flywheel until the adjusting screw can be reached with a screwdriver.

There is no oil pressure shut-off adjustment.

Water Temperature Shut-off: The water temperature safety shut-off attachment in itself is a valve connected with the oil pressure portion of the safety shut-off control. If high water temperature in the cooling system occurs, the valve will open and reduce the lubricating oil pressure in the safety shut-off control and it is actually the safety shut-off control that functions and stops the engine.

BILGE PUMP

Clutch Adjustment: The clutch adjustment should be checked by moving the clutch control lever to the engaged position. It should go in with a distinct snap, and should require a reasonably hard push.

To adjust, disengage the clutch and loosen the setscrew (1). Turn the adjusting collar (2) a few degrees in a clockwise direction; then tighten the setscrew before testing for correct adjustment.

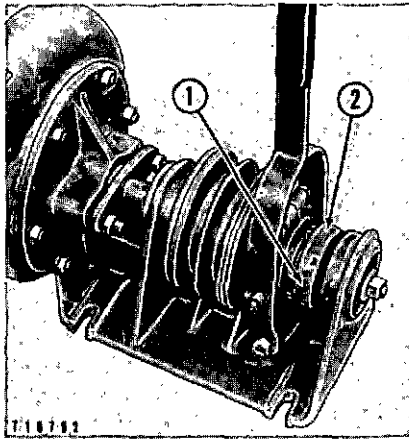

CLUTCH ADJUSTMENT
1-Setscrew. 2-Adjusting collar.

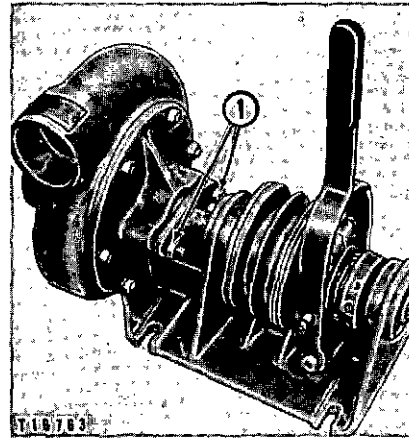

PACKING ADJUSTMENT
1-Nuts.

Packing Adjustment: With the pump in operation tighten the pump shaft packing by tightening the nuts (1) until the leak stops. The packing should be only tight enough to stop any leak, but not tight enough to bind the shaft.

Priming and Draining: When it becomes necessary to prime the pump remove the plug (1) on the front face of the pump and pour water into the pump with the pump not operating. Replace the filler plug and engage the clutch.

A line with a shut-off cock may be connected to the pump in place of the plug (1) and the other end of the line to a water supply for the purpose of priming the pump.

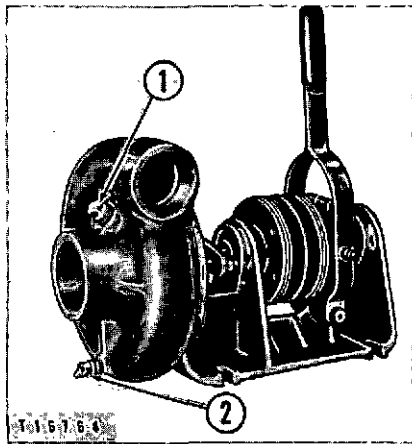

PRIMING AND DRAINING

1-Filler plug. 2-Drain cock.

The pump should be drained when the vessel is to be left in storage, or at the end of a day's run in freezing temperatures. To drain the pump open the drain cock (2).

Open the shut-off cock, if so equipped, to allow the water to drain from the priming line when draining the pump.

FRONT POWER TAKE-OFF

Front Power Take-Off Clutch Adjustment: Remove the inspection cover and rotate the clutch until the lock pin can be reached. Push in the lock

FRONT POWER TAKE-OFF CLUTCH

1-Adjusting lock pin.
2-Adjusting ring.

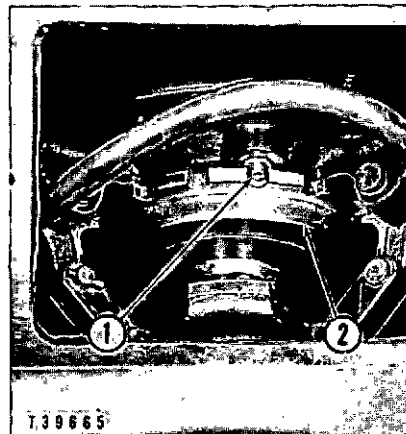

pin (1) and tighten the clutch by turning the adjusting ring (2) to the right or clockwise until the lock pin moves into the next notch. Test the adjustment by engaging the clutch. If one notch gives too tight an adjustment and the other gives a slightly loose adjustment, use the looser adjustment. Replace the inspection cover.

WASHING GEAR COMPARTMENTS

Washing the Starting Engine Transmission: The starting engine transmission should be washed every 1000 service hours. Remove the drain plug after the starting engine has been turning the transmission gears and has warmed the oil. After the oil has drained, replace the drain plug and fill the compartment to the proper level with kerosene or clean diesel fuel. Set the starting and diesel engine controls in the positions as outlined in the topic, STARTING THE ENGINES, then start the starting engine and engage the starting engine clutch. Allow the starting engine to turn the transmission gears for several minutes. Disengage the starting clutch, stop the starting engine and remove the transmission drain plug. After all the cleaning fluid has drained, replace the drain plug and fill the transmission with fresh oil to the correct level as instructed in the LUBRICATION INSTRUCTIONS section of this book.

Index

	Page		Page
Air Cleaners	45	Fuel Tank	51
Correct Air Cleaning Is Necessary	11	Oil Filter Housing	17
Diesel Engine - Dry Type	46-47	Raw Water System	60
Filter Element, Cleaning	48	Electric Starting Methods	
Service Indicator	45	Diesel Engine	30
Starting Engine	66	Starting Engine	28
Air Starting	32	Electrical Equipment	11-42-72-79
Air Supply	32	Engine Mounting and	
Motor Oilier	71	Shaft Alignment	10
Alternator	76	Ether Starting Aid	34-36-37
Belt Adjustment	77	Exhaust Lines	9
Voltage Regulator	11-78	Filter Elements:	
Altitude Operation	44	Air Cleaner	46-47-66
Ammeter	38	Fuel Filter	52
Attachment Instructions	65	Lubricating Oil	17
Ball and Roller Bearing		Front Power Take-off	87
Lubricant	14-16-20	Fuel	38-40-50
Battery	12-43-72	Filter Element	52
Bilge Pump	86	Filtering System	52
Capacities	Inside Back Cover	Injection Equipment	54
Carburetor Adjustment	65	Pumps	56
Care of:		Valves	55
Diesel Fuel Tank	43-51	Lines	9
Fuel Supply	51	Pressure Gauge	38-52
Cleaning Procedures for:		Priming System	53
Air Cleaner Filter Elements	48	Starting Engine System	65
Cooling System	59-61	Supply, Care of the	51
Heat Exchanger	61	Tank, Care of the	43-51
Oil Cooler	60	Gauges	37
Clutch, Starting Engine	70	Ammeter	38
Compression Release Adjustment	63	Fuel Pressure	38-52
Cooling System	8-43-57	Oil Pressure	37
Cleaning	59-61	Water Temperature	37
Coolants	40-57	Generator	75-76
Draining	58-60	Belt Adjustment	77
Filling	57	Voltage Regulator	11-76
Crankcase:		Glow Plug	34-36-79
Breather Fumes Disposal	11	Heat Exchanger	59-61
Lubricating Oil,		Installation Instructions	8
Description	14-16-20	Lubrication	
Oil Change Period Chart	15A	Chart	15A
Daily Care	39	Grease	14
Diesel Fuel Tank, Care of	8-43-51	Information	13-14
Direct Electric Starting	30	Instructions	13-15A
Draining:		Lubricants	14-40
Cooling System	58-60		
Crankcase	16		
Fuel Filter Housing	52		

INDEX—Continued

	Page		Page
Magneto	68	Diesel Engine	25-28-30-32-41
Maintenance Instructions	45	Direct Electric	30
Marine Gear:		Gasoline Starting Engine	26-40
Controls	11	Electric Start	28
Installation	10	Manual Start	27
Manual Starting	27	Starting Aid Chart	34
Model Views	4-7	Starting Aids	33-34-36-79
Oil Pressure	37	Starting Engine	26-43
Alarm Switch	81	Air Cleaner	66
Oil Level Gauge Marking	10	Clutch	70
Oil Specification Chart	15	Draining	20-58
Oil Viscosity Recommendations	15	Flame Arrester	67
Operation Instructions	25	Fuel System	65
Diesel Engine	25-28-30-32-41	Magneto	68
Starting Engine	26-40	Safety Drip Collector	67
Electric Starter	28	Starter Electric	28-79
Manual Starting	27	Starting Method	26-34-40
Panel Type Air Cleaner	46	Valve Clearance Adjustment	67
Position Controls for Starting	28-31-32	Wiring Diagram	74
Preparing the Engine for Use	25	Stopping the:	
Priming the Fuel System	53-54	Diesel Engine	38
Pumps, Fuel Injection	56	Load	38
Raw Water Cooling System	43-60	Starting Engine	30
Resetting the Safety		Storage	43
Shut-off Control	84	Sump Pump	49
Safety Alarm Switches	80	Table of Contents	3
Safety Devices	80-82	Temperature, Operating, Diesel	
Safety Drip Collector	67	Engine	37
Safety Shut-off Control	82-85	Type of Lubricants and SAE	
Sediment Bowl Filter	65	Grades to Use	14
Serial Number Location		Valve Clearance Adjustment	
Inside Back Cover		Diesel Engine	62
Service Meter	13	Starting Engine	67
Single Stage Air Cleaner	47	Valve Rotators, Checking	63
Spark Plug Adjustment	68	Valves, Fuel Injection	55
Specific Gravity, Battery	73	Voltage Regulator	11-76
Starter - Electric:		Washing the Crankcase	49
Diesel Engine	30-79	Washing Gear Compartments	88
Starting Engine	24-27-79	Water Temperature	
Starting Methods:		Alarm Switch	81
Air	32	Gauge	37
Cold Weather	34-36-40	Wiring Diagrams	73-74-75
		Zinc Elements	61

Capacities

Approximate Quantities

	U.S. Measure	Imperial Measure	Metric Measure Liters
Crankcase Lubricating Oil System			
Diesel Engine Only (D379)	50 gal.	41.6 gal.	189,2
(D398)	70 gal.	58.3 gal.	266
Diesel Engine Auxiliary Tank	25 gal.	20.8 gal.	94,6
Starting Engine	2.5 qt.	2.1 qt.	2,4
Starting Engine Transmission	4 qt.	3.4 qt.	3,8
Cooling System			
Diesel Engine (D379)	56 gal.	46.6 gal.	210
(D398)	80 gal.	66.6 gal.	302,7

Location Of Serial Number

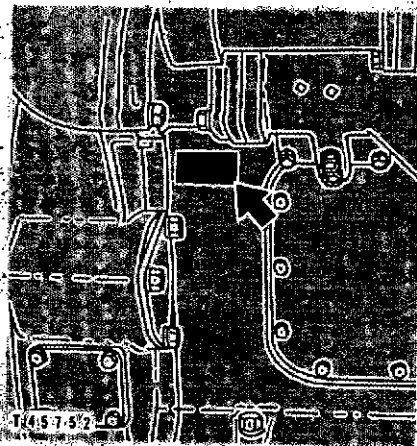

CATERPILLAR

Caterpillar, Cat and Traxcavator are Registered Trademarks
of Caterpillar Tractor Co.

FE045088-01

PRINTED IN U.S.A.