

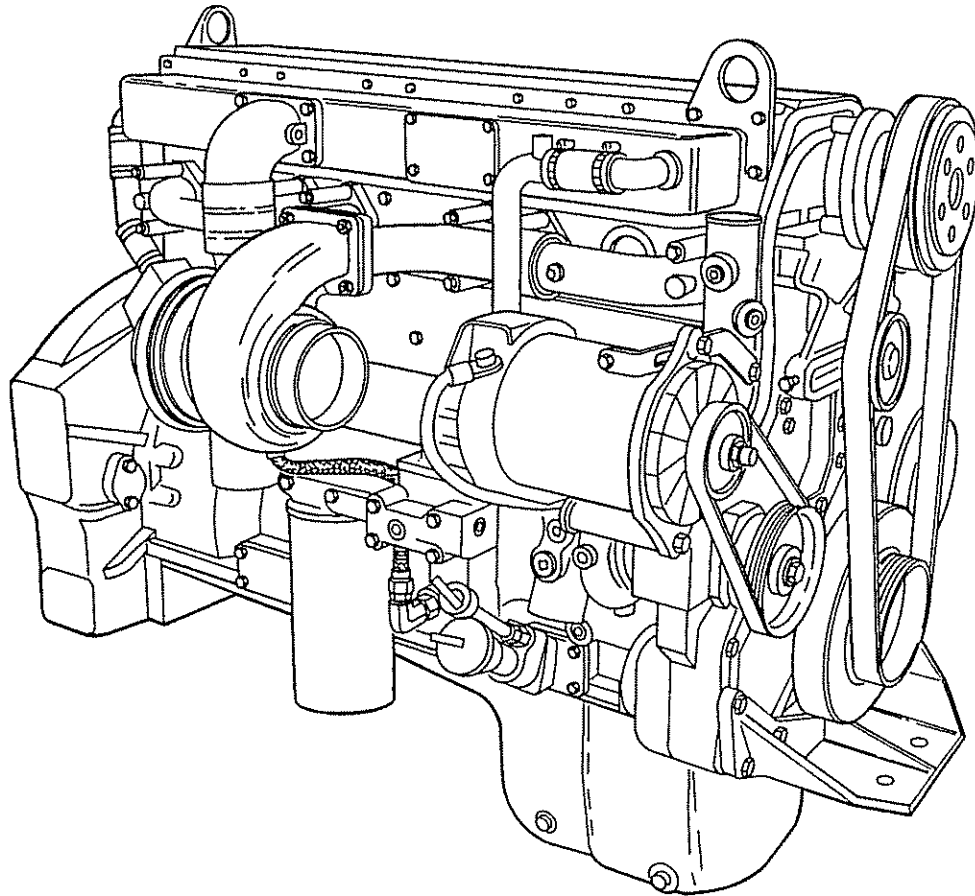

Operation and Maintenance Manual M11 Series Engines Industrial Models



00200010

Foreword

This manual contains information for the correct operation and maintenance of your Cummins engine. It also includes important safety information, engine and systems specifications, troubleshooting guidelines, and listings of Cummins Authorized Repair Locations and component manufacturers.

Read and follow all safety instructions. Refer to the WARNING in the General Safety Instructions in Section i - Introduction.

Keep this manual with the equipment. If the equipment is traded or sold, give the manual to the new owner.



















The information, specifications, and recommended maintenance guidelines in this manual are based on information in effect at the time of printing. Cummins Engine Company, Inc. reserves the right to make changes at any time without obligation. If you find differences between your engine and the information in this manual, contact your local Cummins Authorized Repair Location or call 1-800-DIESELS (1-800-343-7357).

The latest technology and the highest quality components were used to produce this engine. When replacement parts are needed, we recommend using only genuine Cummins or ReCon® exchange parts. These parts can be identified by the following trademarks:



Note: Warranty information is located in Section W. Make sure you are familiar with the warranty or warranties applicable to your engine.

Table of Contents

	Section	
Introduction	i	
Engine Identification	E	
Operating Instructions	1	
Maintenance Guidelines	2	
Maintenance Procedures at Daily Interval	3	
Maintenance Procedures at Weekly Interval	4	
Maintenance Procedures at 250 Hours or 6 Months	5	
Maintenance Procedures at 1,500 Hours	6	
Maintenance Procedures at 6,000 Hours or 2 Years	7	
Maintenance Procedures at 6,000 Hours	8	
Adjustment, Repair and Replacement	A	
System Diagrams	D	
Service Literature	L	
Component Manufacturers	M	
Service Assistance	S	
Troubleshooting Symptoms	TS	
Specifications	V	
Warranty	W	
Index	X	

Important Reference Numbers

Fill in the part name and number in the blank spaces provided below. This will give you a reference whenever service or maintenance is required.

Engine Model		
Engine Serial Number (ESN)		
Control Parts List (CPL)		
Fuel Pump Part Number		
Filter Part Numbers:		
• Air Cleaner Element		
• Lubricating Oil Filter		
– Bypass		
– Full-flow		
– Combination		
• Fuel		
• Fuel-Water Separator		
Belt Part Numbers		

Section i - Introduction

Section Contents

	Page
About the Manual	i-1
Acronyms and Abbreviations.....	i-8
General Safety Instructions.....	i-7
Important Safety Notice	i-7
How to Use the Manual	i-1
Illustrations	i-6
Symbols	i-2
To the Owner and Operator	i-1

THIS PAGE LEFT INTENTIONALLY BLANK.

To the Owner and Operator

Preventative maintenance is the easiest and least expensive type of maintenance. Follow the maintenance schedule recommendations outlined in Maintenance Guidelines (Section 2).

Keep records of regularly scheduled maintenance.

Use the correct fuel, oil, and coolant in your engine as specified in Maintenance Specifications (Section V).

Cummins Engine Company, Inc. uses the latest technology and the highest quality components to produce its engines. Cummins recommends using only genuine Cummins parts and ReCon® exchange parts.

Personnel at Cummins Authorized Repair Locations have been trained to provide expert service and parts support. If you have a problem that **cannot** be resolved by a Cummins Authorized Repair Location, follow the steps outlined in Service Assistance (Section S).

About the Manual

This manual contains information needed to correctly operate and maintain your engine as recommended by Cummins Engine Company, Inc. Additional service literature can be ordered from your Cummins distributor.

This manual does **not** cover vehicle or equipment maintenance procedures. Consult the vehicle or equipment manufacturer for specific maintenance recommendations.

Both metric and U.S. customary values are listed in this manual. The metric value is listed first, followed by the U.S. customary in brackets.

Numerous illustrations and symbols are used to aid in understanding the meaning of the text. Refer to Symbols in this section for a complete listing of symbols and their definitions.

Each section of the manual is preceded by a 'Section Contents' to aid in locating information quickly.

How to Use the Manual

This manual is organized according to intervals at which maintenance on your engine is to be performed. A table (schedule) which gives required intervals and checks to be made is located in Section 2. Locate the interval at which you are performing maintenance then follow the steps given in that section for all the procedures to be performed. In addition, the procedures completed under previous maintenance intervals which are due for scheduled maintenance **must** also be performed.

Keep a record of all the checks and inspections made. A record form for recording date or hours at which maintenance checks were performed is located at the end of Section 2.

Refer to Section TS for a guide to troubleshooting your engine. Follow the directions outlined in 'Troubleshooting Procedures and Techniques' and 'Troubleshooting Symptoms Charts' at the front of that section to locate and correct engine problems.

Refer to Section V for specifications recommended by Cummins Engine Company, Inc. for your engine. Specifications and torque values for each engine system are given in that section.

Symbols

The following symbols have been used in this manual to help communicate the intent of the instructions. When one of the symbols appears, it conveys the meaning defined below:



WARNING - Serious personal injury or extensive property damage can result if the warning instructions are **not** followed.



CAUTION - Minor personal injury can result or a part, an assembly, or the engine can be damaged if the caution instructions are **not** followed.



Indicates a **REMOVAL** or **DISASSEMBLY** step.



Indicates an **INSTALLATION** or **ASSEMBLY** step.



INSPECTION is required.



CLEAN the part or assembly.



PERFORM a mechanical or time **MEASUREMENT**.



LUBRICATE the part or assembly.



Indicates that a **WRENCH** or **TOOL SIZE** will be given.



TIGHTEN to a specific torque.



PERFORM an electrical **MEASUREMENT**.



Refer to another location in this manual or another publication for additional information.



The component weighs 23 kg [50 lb] or more. To avoid personal injury, use a hoist or get assistance to lift the component.

Simbolos

Los símbolos siguientes son usados en este manual para clarificar el proceso de las instrucciones. Cuando aparece uno de estos símbolos, su significado se especifica en la parte inferior.



ADVERTENCIA - Serios daños personales o daño a la propiedad puede resultar si las instrucciones de Advertencia **no** se consideran.



PRECAUCION - Daños menores pueden resultar, o de piezas del conjunto o el motor puede averiarse si las instrucciones de Precaución **no** se siguen.



Indica un paso de **REMOCION** o **DESMONTAJE**.



Indica un paso de **INSTALACION** o **MONTAJE**.



Se requiere **INSPECCION**.



LIMPIESE la pieza o el montaje.



EJECUTESE una **MEDICION** mecánica o del tiempo.



LUBRIQUESE la pieza o el montaje.



Indica que se dará una **LLAVE DE TUERCAS** o el **TAMAÑO DE HERRAMIENTA**.



APRIETESE hasta un par torsor específico.



EJECUTESE una **MEDICION** eléctrica.



Para información adicional refiérase a otro emplazamiento de este manual o a otra publicación anterior.



El componente pesa 23 kg [50 lb] o mas. Para evitar dano corporal empleen una cabria u obtengan ayuda para elevar el componente.

Symbole

In diesem Handbuch werden die folgenden Symbole verwendet, die wesentliche Funktionen hervorheben. Die Symbole haben folgende Bedeutung:



WARNUNG - Wird die Warnung **nicht** beachtet, dann besteht erhöhte Unfall- und Beschädigungsgefahr.



VORSICHT - Werden die Vorsichtsmassnahmen **nicht** beachtet, dann besteht Unfall- und Beschädigungsgefahr.



AUSBAU bzw. **ZERLEGEN**.



EINBAU bzw. **ZUSAMMENBAU**.



INSPEKTION erforderlich.



Teil oder Baugruppe **REINIGEN**.



DIMENSION - oder **ZEITMESSUNG**.



Teil oder Baugruppe **ÖLEN**.



WERKZEUGGRÖSSE wird angegeben.



ANZUG auf vorgeschriebenes Drehmoment erforderlich.



Elektrische **MESSUNG DURCHFÜHREN**.



Weitere Informationen an anderer Stelle bzw. in anderen Handbüchern.



Das teil wiegt 23 kg [50 lb] oder mehr. Zur Vermeidung von Körperverletzung Winde benutzen oder Hilfe beim Heben des teils in Anspruch nehmen.

Symboles

Les symboles suivants sont utilisés dans ce manuel pour aider à communiquer le but des instructions. Quand l'un de ces symboles apparaît, il évoque le sens défini ci-dessous:



AVERTISSEMENT - De graves lésions corporelles ou des dommages matériels considérables peuvent survenir si les instructions données sous les rubriques "Avertissement" ne sont pas suivies.



ATTENTION - De petites lésions corporelles peuvent survenir, ou bien une pièce, un ensemble ou le moteur peuvent être endommagés si les instructions données sous les rubriques "Attention" ne sont pas suivies.



Indique une opération de **DEPOSE**.



Indique une opération de **MONTAGE**.



L'INSPECTION est nécessaire.



NETTOYER la pièce ou l'ensemble.



EFFECTUER une **MESURE** mécanique ou de temps.



GRAISSER la pièce ou l'ensemble.



Indique qu'une **DIMENSION DE CLE** ou **D'OUTIL** sera donnée.



SERRER à un couple spécifique.



EFFECTUER une **MESURE** électrique.



Se reporter à un autre endroit dans ce manuel ou à une autre publication pour obtenir des informations plus complètes.



Le composant pèse 23 kg [50 lb] ou davantage. Pour éviter toute blessure, employer un appareil de levage ou demander de l'aide pour le soulever.

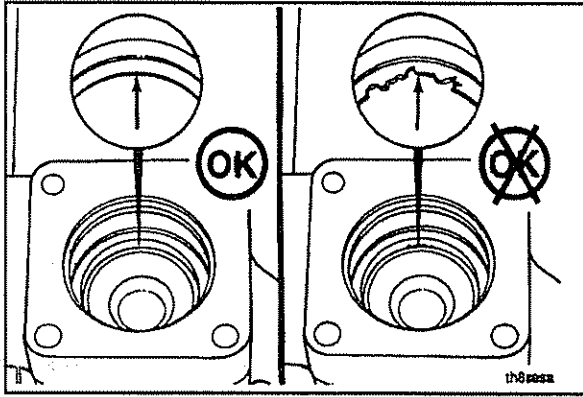

Illustrations

Some of the illustrations throughout this manual are generic and will **not** look exactly like the engine or parts used in your application. The illustrations can contain symbols to indicate an action required and an acceptable or **not** acceptable condition.

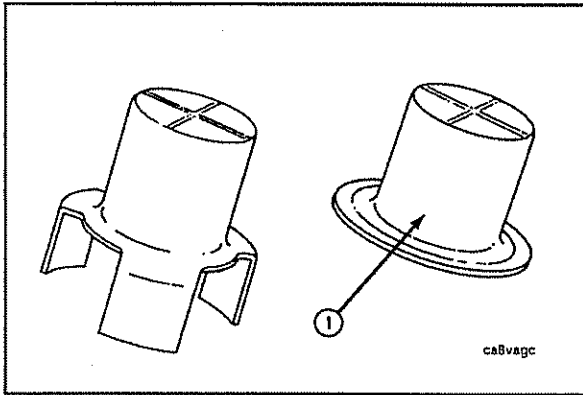

The illustrations are intended to show repair or replacement procedures. The procedure will be the same for all applications, although the illustration can differ.

General Safety Instructions

Important Safety Notice

▲ WARNING ▲

Improper practices or carelessness can cause burns, cuts, mutilation, asphyxiation or other bodily injury or death.

Read and understand all of the safety precautions and warnings before performing any repair. This list contains the general safety precautions that **must** be followed to provide personal safety. Special safety precautions are included in the procedures when they apply.

- Make sure the work area surrounding the product is dry, well lit, ventilated, free from clutter, loose tools, parts, ignition sources and hazardous substances. Be aware of hazardous conditions that can exist.
- **Always** wear protective glasses and protective shoes when working.
- Rotating parts can cause cuts, mutilation or strangulation.
- Do **not** wear loose-fitting or torn clothing. Remove all jewelry when working.
- Disconnect the battery (negative [-] cable first) and discharge any capacitors before beginning any repair work. Disconnect the air starting motor if equipped to prevent accidental engine starting. Put a "Do **Not** Operate" tag in the operator's compartment or on the controls.
- Use **ONLY** the proper engine barring techniques for manually rotating the engine. Do **not** attempt to rotate the crankshaft by pulling or prying on the fan. This practice can cause serious personal injury, property damage, or damage to the fan blade(s) causing premature fan failure.
- If an engine has been operating and the coolant is hot, allow the engine to cool before you slowly loosen the filler cap and relieve the pressure from the cooling system.
- Do **not** work on anything that is supported **ONLY** by lifting jacks or a hoist. **Always** use blocks or proper stands to support the product before performing any service work.
- Relieve all pressure in the air, oil, fuel and the cooling systems before any lines, fittings, or related items are removed or disconnected. Be alert for possible pressure when disconnecting any device from a system that utilizes pressure. Do **not** check for pressure leaks with your hand. High pressure oil or fuel can cause personal injury.
- To prevent suffocation and frostbite, wear protective clothing and **ONLY** disconnect fuel and liquid refrigerant (freon) lines in a well ventilated area. To protect the environment, liquid refrigerant systems **must** be properly emptied and filled using equipment that prevents the release of refrigerant gas (fluorocarbons) into the atmosphere. Federal law requires capturing and recycling refrigerant.
- To avoid personal injury, use a hoist or get assistance when lifting components that weigh 23 kg [50 lb] or more. Make sure all lifting devices such as chains, hooks, or slings are in good condition and are of the correct capacity. Make sure hooks are positioned correctly. **Always** use a spreader bar when necessary. The lifting hooks **must not** be side-loaded.
- Corrosion inhibitor, a component of SCA and lubricating oil, contains alkali. Do **not** get the substance in your eyes. Avoid prolonged or repeated contact with skin. Do **not** swallow internally. In case of contact, immediately wash skin with soap and water. In case of contact, immediately flood eyes with large amounts of water for a minimum of 15 minutes. **IMMEDIATELY CALL A PHYSICIAN. KEEP OUT OF REACH OF CHILDREN.**
- Naptha and Methyl Ethyl Ketone (MEK) are flammable materials and **must** be used with caution. Follow the manufacturer's instructions to provide complete safety when using these materials. **KEEP OUT OF REACH OF CHILDREN.**
- To avoid burns, be alert for hot parts on products that have just been turned off, and hot fluids in lines, tubes, and compartments.
- **Always** use tools that are in good condition. Make sure you understand how to use them before performing any service work. Use **ONLY** genuine Cummins or Cummins ReCon® replacement parts.
- **Always** use the same fastener part number (or equivalent) when replacing fasteners. Do **not** use a fastener of lesser quality if replacements are necessary.
- Do **not** perform any repair when fatigued or after consuming alcohol or drugs that can impair your functioning.
- Some state and federal agencies in the United States of America have determined that used engine oil can be carcinogenic and can cause reproductive toxicity. Avoid inhalation of vapors, ingestion, and prolonged contact with used engine oil.

Acronyms and Abbreviations

AFC	Air Fuel Control	km/l	Kilometers per Liter
API	American Petroleum Institute	kPa	Kilopascal
ASA	Air Signal Attenuator	LNG	Liquid Natural Gas
ASTM	American Society of Testing and Materials	LTA	Low Temperature Aftercooling
°C	Celsius	MIP	Mixer Inlet Pressure
CARB	California Air Resources Board	MPa	Megapascal
C.I.D.	Cubic Inch Displacement	mph	Miles Per Hour
CNG	Compressed Natural Gas	mpq	Miles Per Quart
CPL	Control Parts List	N•m	Newton-meter
cSt	Centistokes	NG	Natural Gas
ECM	Electronic Control Module	OEM	Original Equipment Manufacturer
ECS	Emission Control System	ppm	Parts Per Million
EPA	Environmental Protection Agency	psi	Pounds Per Square Inch
EPS	Engine Position Sensor	PTO	Power Takeoff
°F	Fahrenheit	rpm	Revolutions Per Minute
GVW	Gross Vehicle Weight	SAE	Society of Automotive Engineers
Hg	Mercury	SCA	Supplemental Coolant Additive
hp	Horsepower	STC	Step Timing Control
H₂O	Water	VS	Variable Speed
ICM	Ignition Control Module	VSS	Vehicle Speed Sensor

Section E - Engine Identification

Section Contents

	Page
Engine Diagrams	E-4
Engine Identification	E-1
Cummins Engine Nomenclature	E-1
Engine Dataplate	E-1
Fuel Pump Dataplate	E-1
Specifications	E-2
Air Intake System	E-3
Batteries (Specific Gravity)	E-3
Cooling System	E-2
Electrical System	E-3
Exhaust System	E-3
Fuel System	E-2
General Specifications	E-2
Lubricating Oil System	E-2

THIS PAGE LEFT INTENTIONALLY BLANK.

Engine Identification

Engine Dataplate

The engine dataplate shows specific information about your engine. The engine serial number and control parts list (CPL) provide information for ordering parts and service needs. The engine dataplate **must not** be changed unless approved by Cummins Engine Company, Inc.

The dataplate is located on the fuel pump side of the engine, on the side of the rocker housing. Have the following engine data available when communicating with a Cummins Authorized Repair Location. The information on the dataplate is **mandatory** when sourcing service parts.

1. Engine Serial Number (ESN)
2. Control Parts List (CPL)
3. Model
4. Horsepower and rpm rating

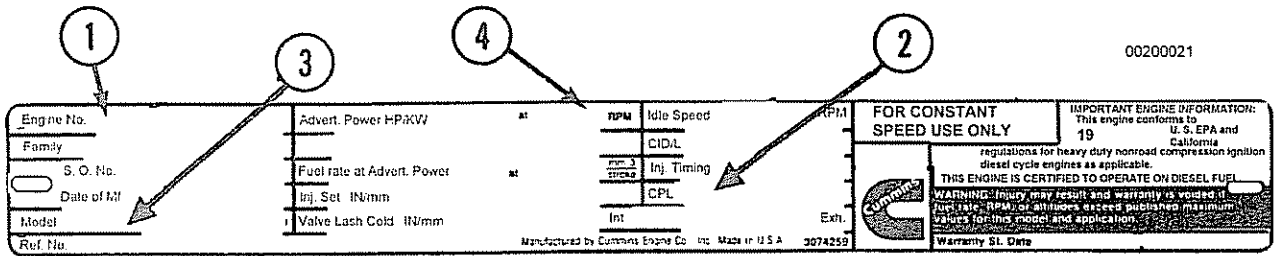
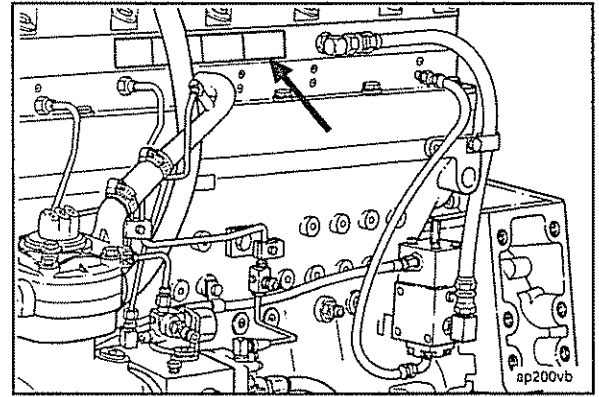

Fuel Pump Dataplate

The fuel pump dataplate is located on the top of the fuel pump. It provides information for fuel pump calibration.

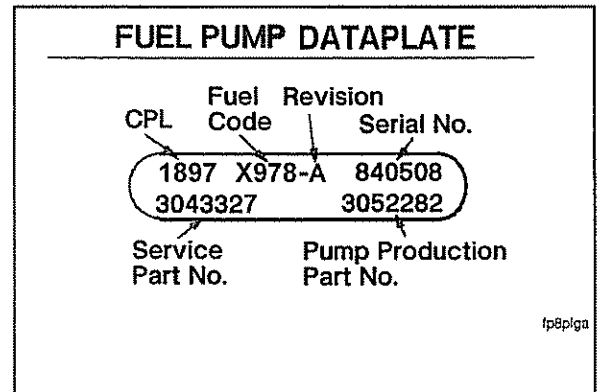

Cummins Engine Nomenclature

The Cummins engine nomenclature provides the data as illustrated in the graphic.

NOTE: The following letters designate some of the different market applications for a Cummins engine.

- A = Agriculture
- C = Construction
- G = Generator Drive

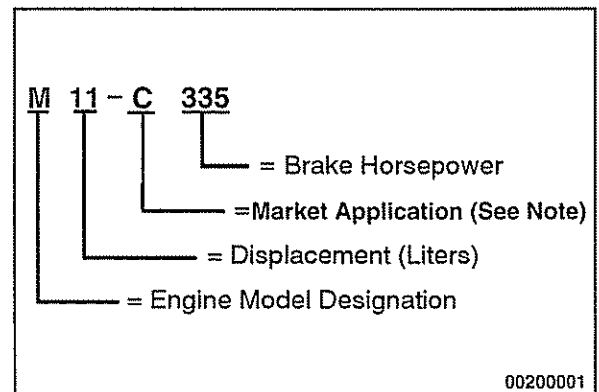

Specifications

General Specifications

Horsepower (Refer to engine dataplate)

Engine speed @ Maximum Output:

Standard Rating (rpm) 2100

Bore and Stroke 125 mm [4.921 in] x 147 mm [5.787 in]

Displacement 10.8 liters [661 C.I.D.]

Firing Order 1-5-3-6-2-4

Engine Weight (with Standard Accessories):

Dry Weight 929 Kg [2045 lb]

Wet Weight 981 Kg [2160 lb]

Crankshaft Rotation — (viewed from the front of the engine) Clockwise

Fuel System

For performance and fuel rate values, refer to the engine data sheet or the fuel pump code for the particular model involved.

Fuel Inlet Maximum Restriction:

Clean Fuel Filter 102 mm Hg [4 in Hg]

Dirty Fuel Filter 204 mm Hg [8 in Hg]

Fuel Drain Line Maximum Restriction

Without Check Valves 63 mm Hg [2.5 in Hg]

With Check Valves 165 mm Hg [6.5 in Hg]

Fuel Inlet Maximum Temperature 71°C [160°F]

Engine Minimum Cranking Speed 150 RPM

Lubricating Oil System

Oil Pressure:

Low Idle (Minimum Allowable) 70 kPa [10 psi]

At 1200 rpm or Torque Peak (Minimum Allowable) 207 kPa [30 psi]

Oil Capacity of Standard Engine:

Combination Filter 2.6 liters [0.7 U.S. gallon]

Oil Pan (High-Low) 34 - 26.5 liters [9 - 7 U.S. gallon]

Cooling System

Coolant Capacity (Engine only-Aftercooled) 12.9 liters [3.4 U.S. gal.]

Standard Modulating Thermostat-Range 82° to 93°C [180 to 200°F]

Cylinder Block Coolant Pressure (Pressure Cap Removed):

Minimum

Closed Thermostat - 1800 RPM - No Load 138 kPa [20 psi]

Maximum

Closed Thermostat 275 kPa [40 psi]

Maximum Allowable Operating Temperature 100°C [212°F]

Minimum Recommended Operating Temperature 71°C [160°F]

Maximum Allowable Deaeration Time 35 minutes

Minimum Recommended Pressure Cap 48 kPa [7 psi]

Air Intake System

Maximum Temperature Rise Between Ambient Air and Engine Inlet Air:
(Ambient (Above 0° [32°F]) 17°C [30°F]

Maximum Intake Restriction (Clean Air Filter Element) 254 mm H₂O [10.0 in H₂O]

Maximum Intake Restriction (Dirty Air Filter Element) 635 mm H₂O [25.0 in. H₂O]

Exhaust System

Maximum Back Pressure From Piping and Silencer (Combined):

Hg 76 mm [3 in]

H₂O 1016 mm [40 in]

Exhaust Pipe Size (Normally Acceptable Inside Diameter) 102 mm [4 in.]

Electrical System

Minimum Recommended Battery Capacity

System Voltage	Ambient Temperature			
	-18°C [0°F]		0°C [32°F]	
	Cold Cranking Amperes	Reserve Capacity ¹ Amperes	Cold Cranking Amperes	Reserve Capacity ¹ Amperes
12 Volt	1800	640	1280	480
24 Volt ²	900	320	640	240

1. The number of plates within a given battery size determines reserve capacity. Reserve capacity determines the length of time which sustained cranking can occur.
2. CCA ratings are based on two 12 volt batteries in series.

A minimum of 9 volts at the ECM connector is required to power-up the ECM on CENTRY engines.

Batteries (Specific Gravity)

Specific Gravity at 27°C [80°F]	State of Charge
1.260 to 1.280	100%
1.230 to 1.250	75%
1.200 to 1.220	50%
1.170 to 1.190	25%
1.110 to 1.130	Discharged

Engine Diagrams

The following illustrations contain information about engine components, filter locations, drain points and access locations for instrumentation and engine controls. The information and configuration of components shown in these drawings are of a general nature. Some component locations will vary depending on applications and installations.

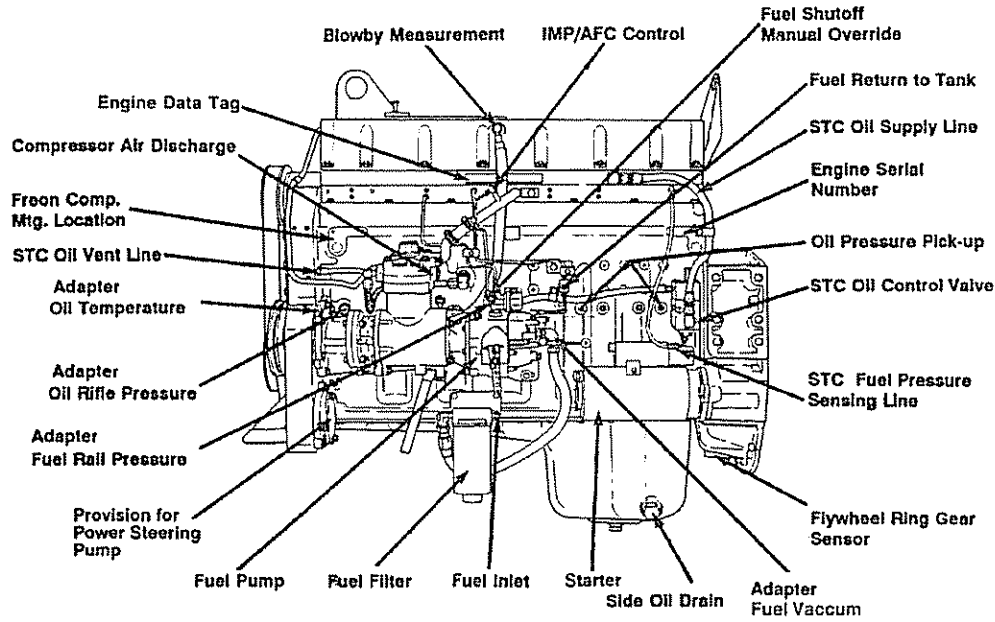

STC Fuel Pump Side

0m200g3

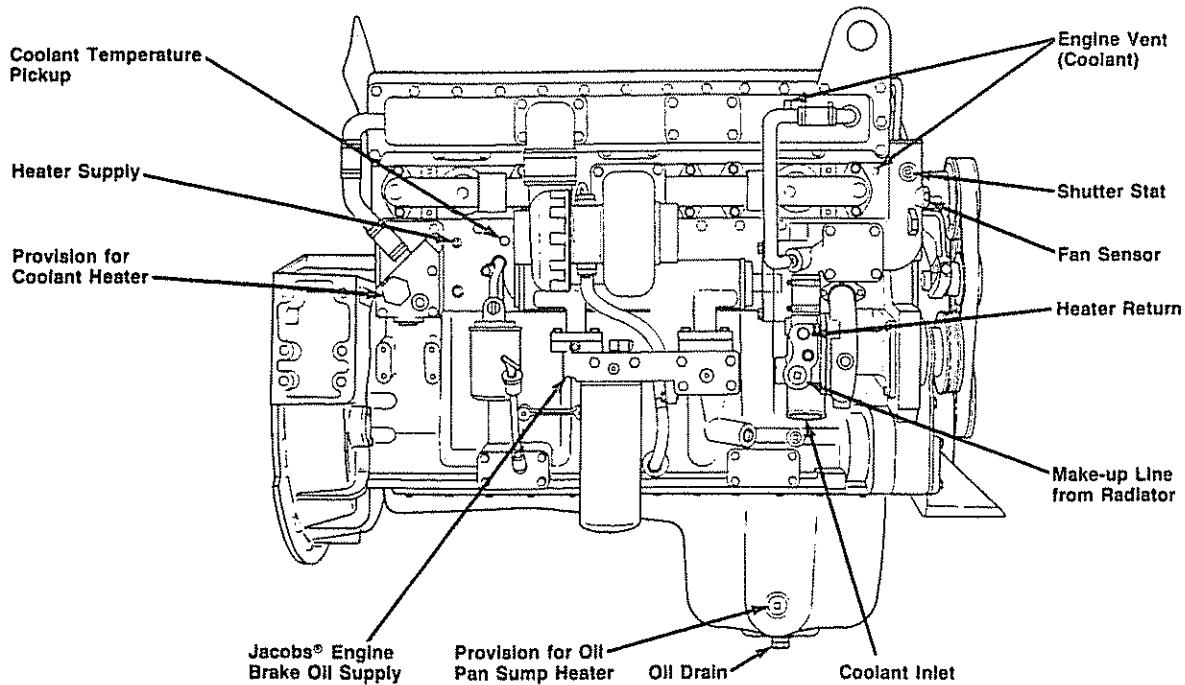

Exhaust Side

00200002

Section 1 - Operating Instructions

Section Contents

	Page
Cold Weather Operation	1-7
Shutters	1-9
Thermo Control Settings	1-8
Winterfronts	1-9
Cold Weather Starting Using Starting Fluid	1-4
With Mechanical or Electrical Metering Equipment (Ether).....	1-4
Engine Operating Range	1-6
Engine Shutdown	1-9
Normal Starting Procedure	1-2
Operating Instructions - General Information	1-1
Operating the Engine	1-5
PTO Application with Variable Speed	1-9

THIS PAGE LEFT INTENTIONALLY BLANK.

Operating Instructions - General Information

Correct care of your engine will result in longer life, better performance and more economical operation.

Follow the daily maintenance checks listed in Maintenance Guidelines, Section 2.

The new Cummins engine associated with this manual does **not** require a 'break-in' procedure. Section 1 of this manual provides all of the necessary information required for proper engine operation.



M11 Engine Maintenance Schedule					
Check or Replenish	Check	Change	Adjust	Check	Check and Lubricate
<ul style="list-style-type: none"> Oil level Water level Coolant level 	<ul style="list-style-type: none"> Air filter (replace or clean) Paralleling air filter Paralleling air filter Paralleling air filter Paralleling air filter Paralleling air filter 	<ul style="list-style-type: none"> Lubricants (oil) Paralleling oil Paralleling oil Paralleling oil Paralleling oil Paralleling oil 	<ul style="list-style-type: none"> Valves and injectors 	<ul style="list-style-type: none"> Control air system 	<ul style="list-style-type: none"> Injectors Fuel pump
<ul style="list-style-type: none"> Control air system Water level Paralleling air filter Paralleling air filter Paralleling air filter 	<ul style="list-style-type: none"> Air filter (replace or clean) Paralleling air filter Paralleling air filter Paralleling air filter Paralleling air filter 	<ul style="list-style-type: none"> Lubricants (oil) Paralleling oil Paralleling oil Paralleling oil Paralleling oil 	<ul style="list-style-type: none"> Valves and injectors 	<ul style="list-style-type: none"> Control air system 	<ul style="list-style-type: none"> Injectors Fuel pump
<ul style="list-style-type: none"> Oil level Water level Paralleling air filter Paralleling air filter 	<ul style="list-style-type: none"> Air filter (replace or clean) Paralleling air filter Paralleling air filter 	<ul style="list-style-type: none"> Lubricants (oil) Paralleling oil Paralleling oil 	<ul style="list-style-type: none"> Valves and injectors 	<ul style="list-style-type: none"> Control air system 	<ul style="list-style-type: none"> Injectors Fuel pump

NOTE: Refer to the applicable sections in service operation and maintenance procedures.

- Follow the scheduled maintenance and operational recommendations for all non-Cummins components and accessories. Cummins accessories include an alternator, alternator belt, battery, battery charger, and battery disconnect switch. The battery disconnect switch must be performed at least every 12 months or 12 months, whichever ever occurs first.
- These maintenance intervals must be performed at least in parallel, otherwise adjust the. At each scheduled maintenance interval, perform the scheduled maintenance procedures which are due to scheduled maintenance.
- Do not change the correct filter if the RCA recommendation level is over 3 years.

00200018

Check the oil pressure indicators, temperature indicators, warning lights, and other gauges daily to make sure they are operational.

Avoid exposure of your engine to corrosive chemicals.

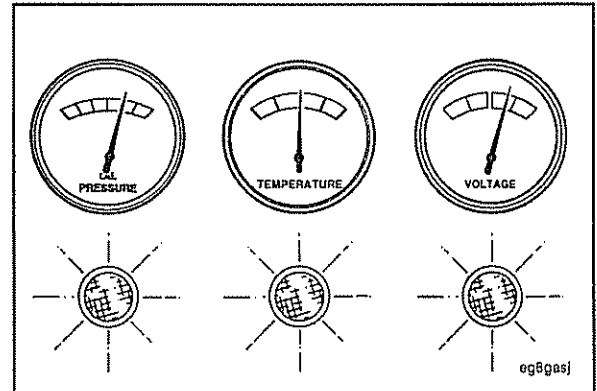

▲ WARNING ▲

DO NOT OPERATE A DIESEL ENGINE WHERE THERE ARE OR CAN BE COMBUSTIBLE VAPORS. These vapors can be sucked through the air intake system and cause engine acceleration and over-speeding which can result in a fire, an explosion, and extensive property damage. Numerous safety devices are available, such as air intake shutoff devices, to minimize the risk of over-speeding where an engine, due to its application, might operate in a combustible environment, such as due to a fuel spill or gas leak. Remember, Cummins has no way of knowing the use you have for your engine. **THE EQUIPMENT OWNER AND OPERATOR ARE RESPONSIBLE FOR SAFE OPERATION IN A HOSTILE ENVIRONMENT. CONSULT YOUR CUMMINS AUTHORIZED REPAIR LOCATION FOR FURTHER INFORMATION.**

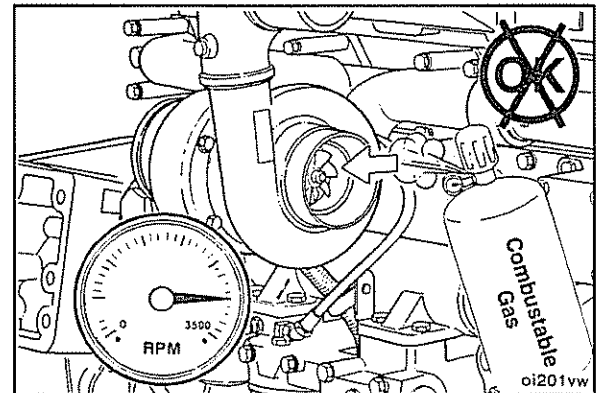

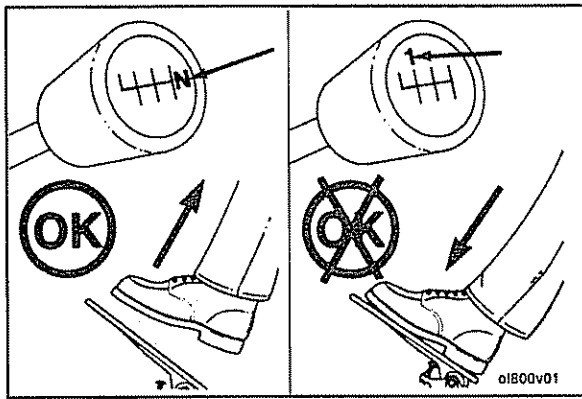

Normal Starting Procedure

⚠ CAUTION ⚠

To prevent damage to the starting motor, do not engage the starting motor more than 30 seconds. Wait 2 minutes between each attempt to start (electrical starting motors only).

- Disengage the driven unit, or if equipped, put the transmission in neutral.
- Activate the ignition switch to open the fuel pump shutoff valve.
- Start the engine with the throttle in the idle position.

NOTE: Engines equipped with air starting motors require a minimum of 480 kPa [70 psi].

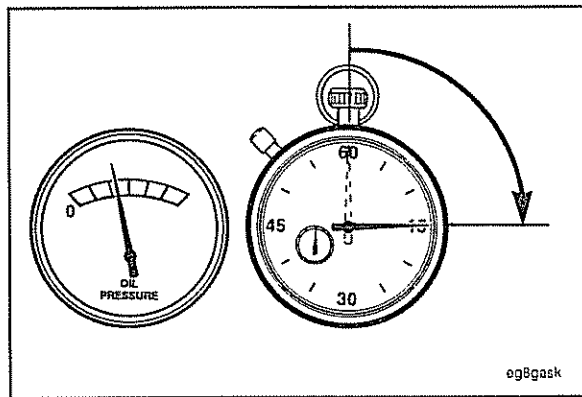

The engine **must** have adequate oil pressure within 15 seconds after starting. If the warning light indicating low oil pressure has **not** gone out or there is no oil pressure indicated on a gauge within 15 seconds, shut off the engine immediately to avoid engine damage. Confirm the correct oil level in the oil pan.

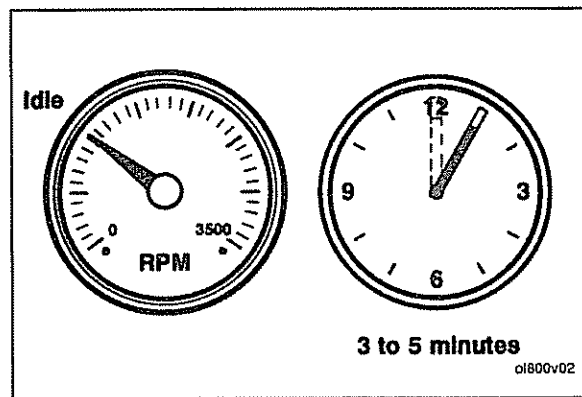

Idle the engine 3 to 5 minutes before operating with a load.

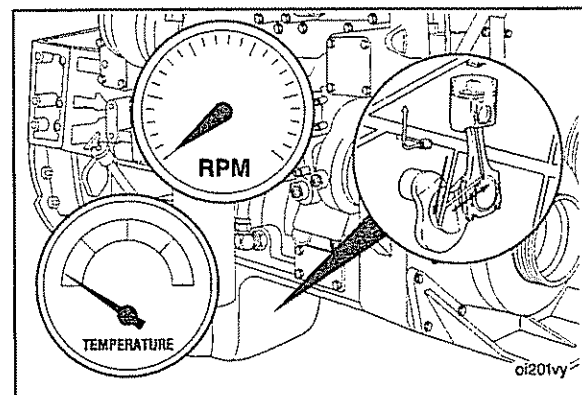

Increase the engine speed (rpm) slowly to provide adequate lubrication to the bearings and to allow the oil pressure to stabilize.

Do not keep the engine at low idle for long periods. Long periods at low idle, more than 10 minutes, can damage an engine because combustion chamber temperatures drop so low the fuel will **not** burn completely. This will cause carbon to build up around the injector spray holes and piston rings and can cause the valves to stick.

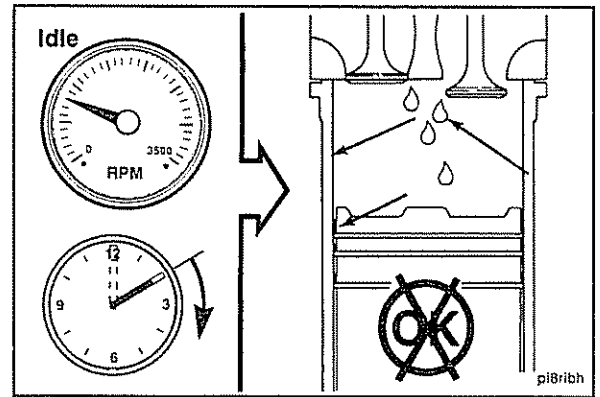

If the engine coolant temperature becomes too low, below 60°C [140°F], raw fuel will wash the lubricating oil off the cylinder walls and dilute the crankcase oil. Fuel dilution adversely affects lubricating oil properties and can shorten engine life. Utilize the fast idle to prevent these conditions.

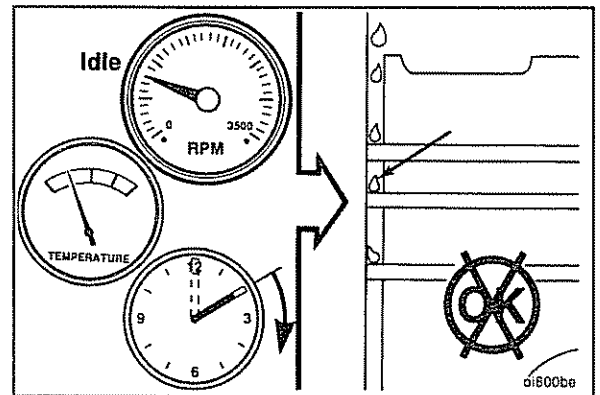

▲ WARNING ▲

To avoid possible arcing, always disconnect the negative (-) cable first, and connect it last.

▲ CAUTION ▲

When using jumper cables to start the engine, make sure to connect the cables in parallel: positive (+) to positive (+) and negative (-) to negative (-). When using an external electrical source to start the engine, turn the disconnect switch to the "OFF" position. Remove the key before attaching the jumper cables.

The accompanying illustration shows a typical parallel battery connection. This arrangement doubles the cranking amperage.

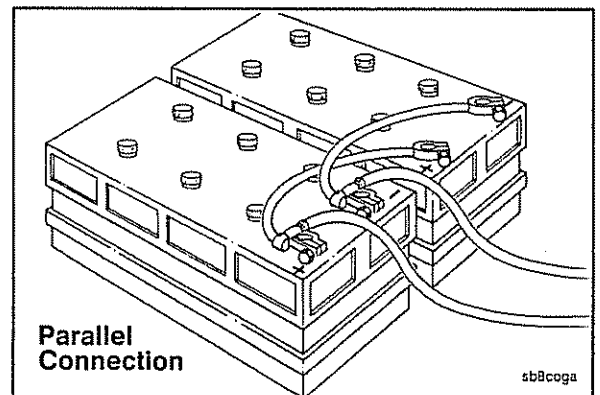

This illustration shows a typical series battery connection. This arrangement, positive to negative, doubles the voltage.

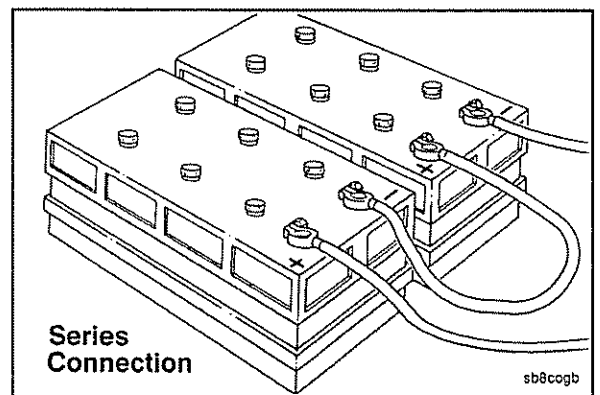

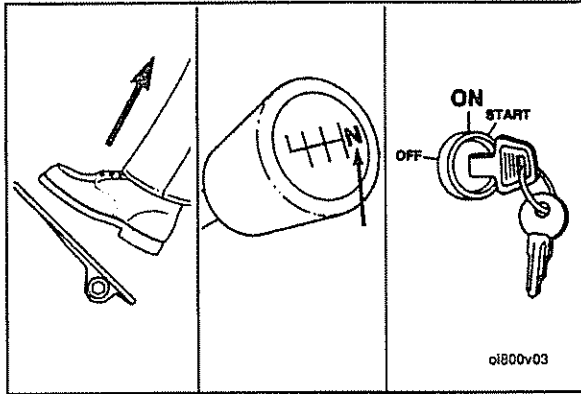

Cold Weather Starting Using Starting Fluid

With Mechanical or Electrical Metering Equipment (Ether)

1. Set the throttle at idle.
2. Disengage any driven accessories and put the transmission in neutral.
3. Activate the ignition switch to open the fuel pump shutoff valve.

▲ WARNING ▲

Do not use volatile cold starting aids in underground mine or tunnel operations due to the potential of an explosion. Check with the local U.S. Bureau of Mines Inspector for instructions.

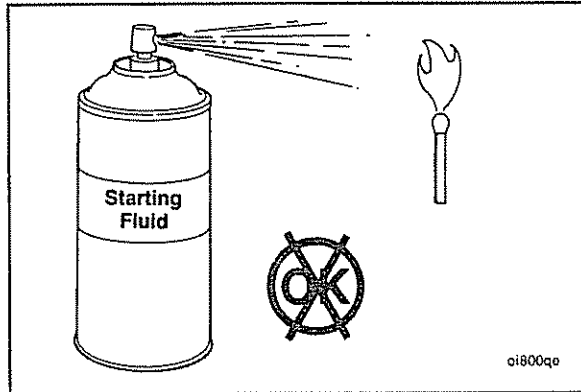

▲ WARNING ▲

Starting fluid is highly flammable and explosive. Keep flames, sparks, and arcing switches away from starting fluid.

Due to increased safety hazards and potential for engine damage, do **NOT** use starting fluid without metering equipment.

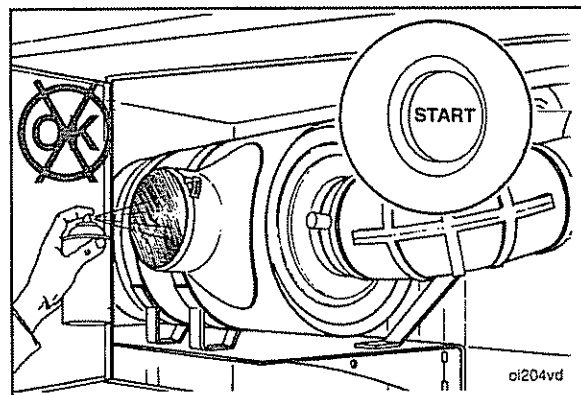

▲ CAUTION ▲

Do not use excessive amounts of starting fluid when starting an engine. The use of too much starting fluid will cause engine damage.

4. While cranking the engine, inject a metered amount of starting fluid.

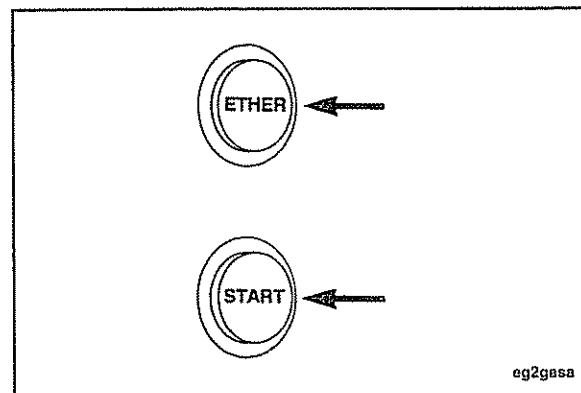

The engine **must** have adequate oil pressure within 15 seconds after starting. If the warning light indicating low oil pressure has **not** gone out or there is no oil pressure indicated on a gauge within 15 seconds, shut off the engine immediately to avoid engine damage. Confirm the correct oil level in the oil pan.

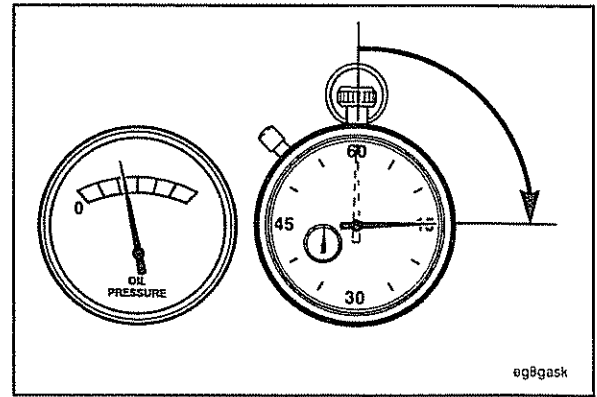

Do **not** increase the engine speed above low idle until the coolant temperature gauge needle starts to move or 10 minutes have elapsed. This will provide adequate lubrication to the bearings.

Monitor the oil pressure after normal operation is initiated.

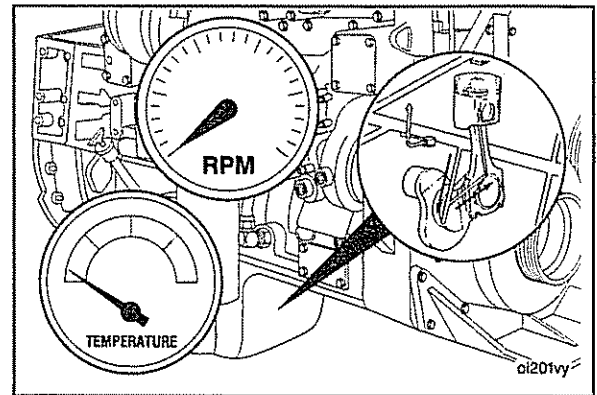

Operating the Engine

Monitor the oil pressure and coolant temperature gauges frequently. Refer to Lubricating Oil System Specifications or Cooling System Specifications, in Section V, for recommended operating pressures and temperatures. Shut off the engine if any pressure or temperature does **not** meet the specifications.

NOTE: Continuous operation with a low coolant temperature, below 60°C [140°F], or a high coolant temperature, above 100°C [212°F], can damage the engine.

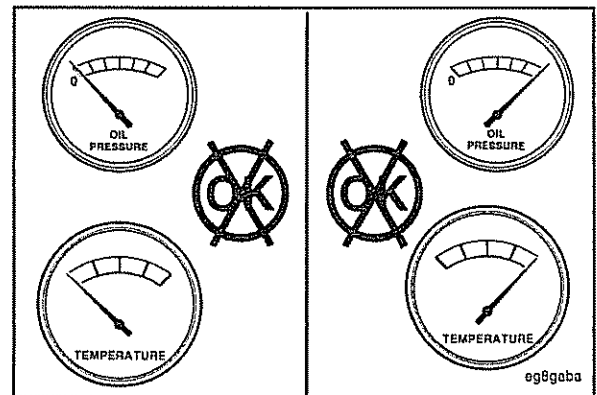

If an overheating condition starts to occur, reduce the power output of the engine by releasing the throttle pedal pressure or shifting the transmission to a lower gear, or both, until the temperature returns to the normal operating range. If the engine temperature does **not** return to normal, shut off the engine and refer to Troubleshooting Symptoms, Section TS, or contact a Cummins Authorized Repair Location.

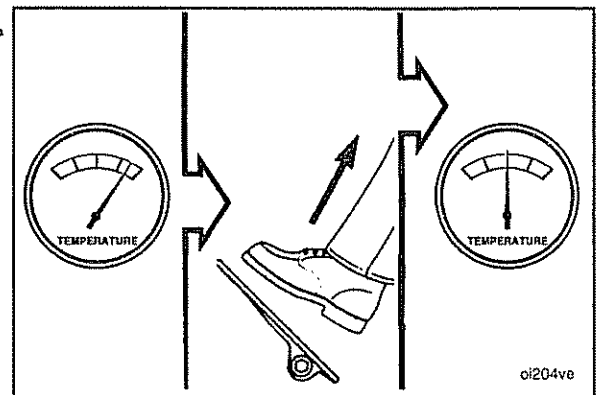

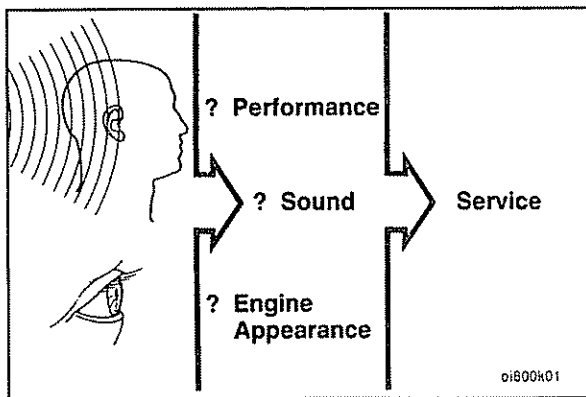

Most failures give an early warning. Look and listen for changes in performance, sound, or engine appearance that can indicate service or engine repair is needed. Some changes to look for are as follows:

- Engine misfires
- Vibration
- Unusual engine noises
- Sudden changes in engine operating temperatures or pressures
- Excessive smoke
- Loss of power
- An increase in oil consumption
- An increase in fuel consumption
- Fuel, oil, or coolant leaks

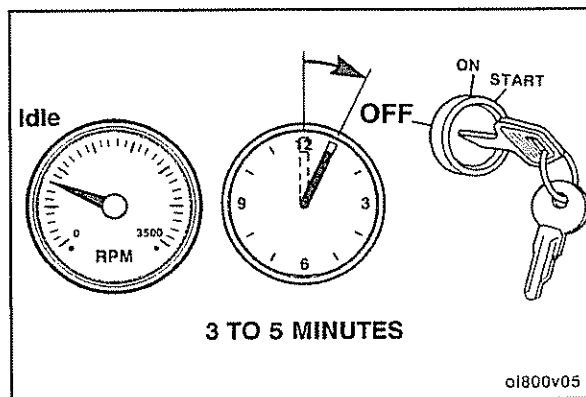

Allow the engine to idle 3 to 5 minutes before shutting it off after a full load operation. This allows adequate cool down of pistons, cylinder liners, bearings, and turbocharger components.

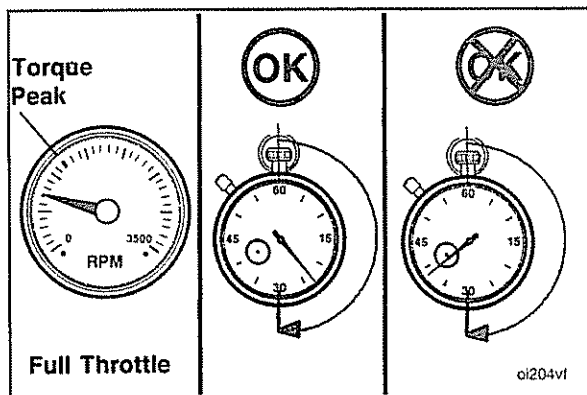

Engine Operating Range



Do not operate the engine at excessive full throttle operation below peak torque rpm (refer to engine dataplate for peak torque rpm) for more than 30 seconds. This condition will shorten engine life to overhaul, can cause serious engine damage, and is considered driver abuse.

Cummins engines are designed to operate successfully at full throttle under transient conditions down to peak torque engine speed. This is consistent with recommended operating practices.



Do not operate the engine beyond high idle speed. Operating the engine beyond high idle speed can cause severe engine damage. The engine speed must not exceed 2,450 rpm under any circumstances. When descending a steep grade, use a combination of transmission gears and engine or service brakes to control the vehicle and engine speed.



To prevent damage to the camshaft and the valve train when using an engine compression brake, do not exceed governed speed.

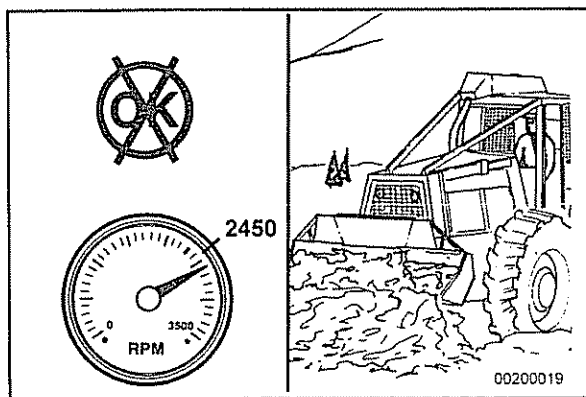

Cold Weather Operation

It is possible to operate diesel engines in extremely cold environments if they are properly prepared and maintained. The correct lubricants, fuels, and coolant **must** be used for the cold weather range for which the vehicle is being operated. Refer to the chart below for recommendations in different operating ranges.

Winterize 0° to -23°C [32° to -10°F]	Winterize -23° to -32°C [-10° to -25°F]	Arctic Specifications -32° to -54°C [-25° to -65°F]
<p>Use 50 percent ethylene glycol antifreeze and 50 percent water in your coolant mixture.</p> <p>Use multi viscosity oil meeting API, CG-4 or CF-4 specifications.</p> <p>Fuel to have maximum cloud and pour points 6°C [10°F] lower than ambient temperature in which engine operates.</p>	<p>Use 50 percent ethylene glycol antifreeze and 50 percent water in your coolant mixture.</p> <p>Use multi viscosity oil meeting API CG-4 or CF-4 specifications.</p> <p>Fuel to have maximum cloud and pour points 6°C [10°F] lower than ambient temperatures in which engine operates.</p>	<p>Use 60 percent ethylene glycol antifreeze and 40 percent water in your coolant mixture.</p> <p>Use Arctic oil meeting API CG-4 or CF-4 specifications.</p> <p>Fuel to have maximum cloud and pour points 6°C [10°F] lower than ambient temperature in which engine operates.</p>

The following cold weather operating aids are required for cold weather situations:

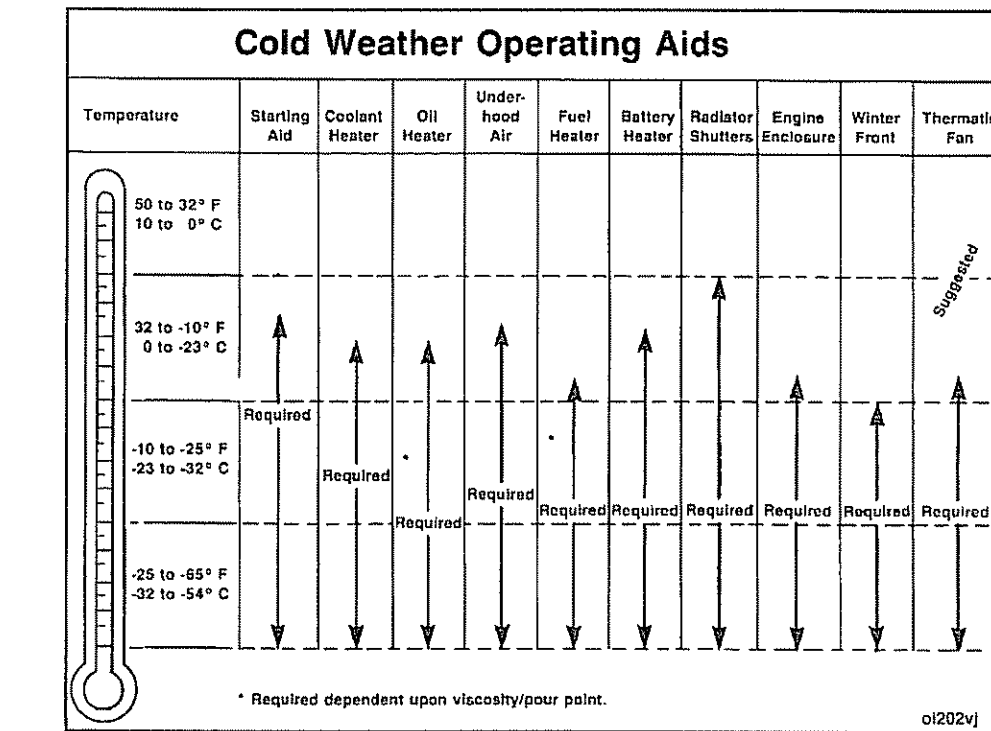

Thermo Control Settings

The temperatures listed in this chart for coolant temperature sensing fan control and intake manifold temperature sensing fan control are correct for vehicles which allow the ECM to control the on/off operation of the cooling fan. Consult your local OEM for other types of control.

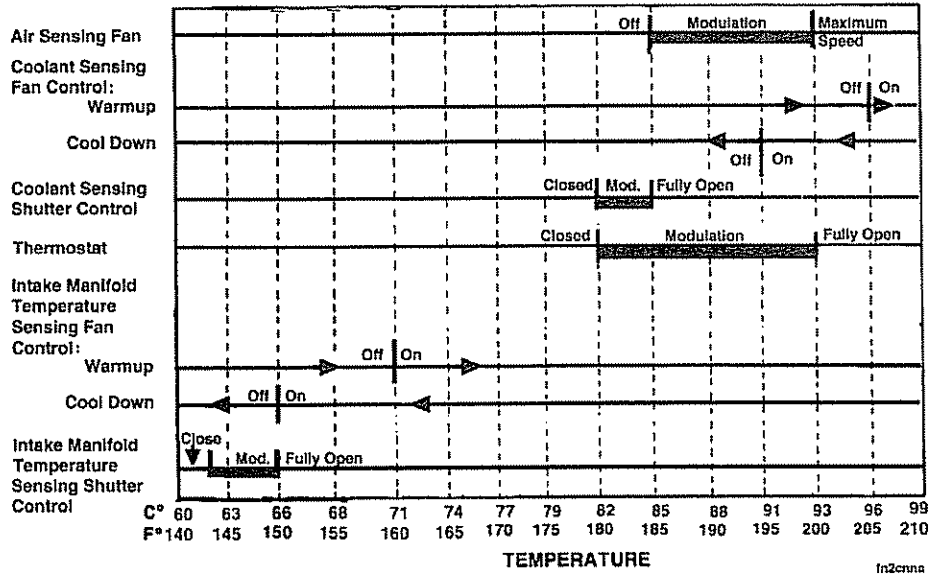

Winterfronts

Canvas or plastic "winterfront" and "engine compartment covers" can be required when operating in cold temperatures. Winterfront and engine compartment covers will protect the engine and engine compartment from cold air flow and eliminate shutter leakage. Winterfronts are designed so that the cover opening **must** be adjusted manually depending on the ambient temperature and operation of the radiator shutters. Engine compartment covers **must not** restrict the air intake and exhaust systems during operation.

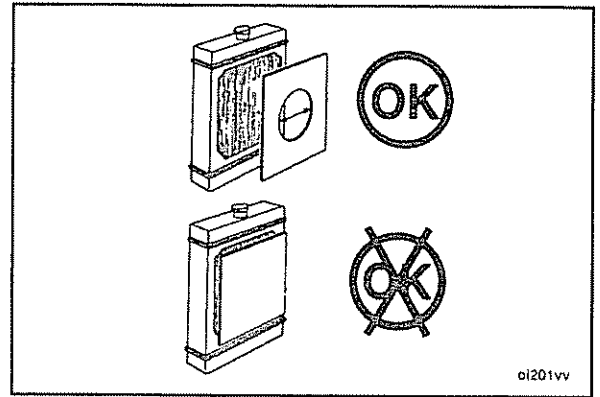

Shutters

The flow of air across the radiator core into the engine compartment can be prevented by installing radiator shutters. Because air flow has a major effect on heat loss through radiation, reducing the air flow with shutters will reduce the time required for engine warm-up and help maintain engine operating temperature.

Shutters **must** operate in the same temperature range as the thermostat with which they are used.

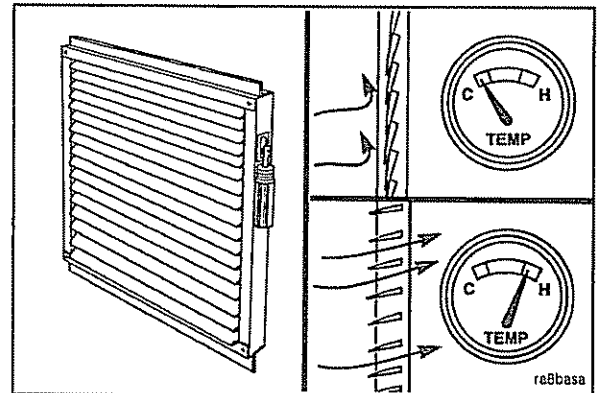

Engine Shutdown

1. Allow the engine to idle 3 to 5 minutes before shutting it off after a full load operation. This allows adequate cool down of pistons, cylinders, bearings, and turbo-charger components.
2. Turn the ignition key switch to the "OFF" position.

NOTE: If the engine fails to stop running, rotate the manual fuel shutoff thumb screw **counterclockwise** to make sure the valve is **not** being held open by the manual override screw.

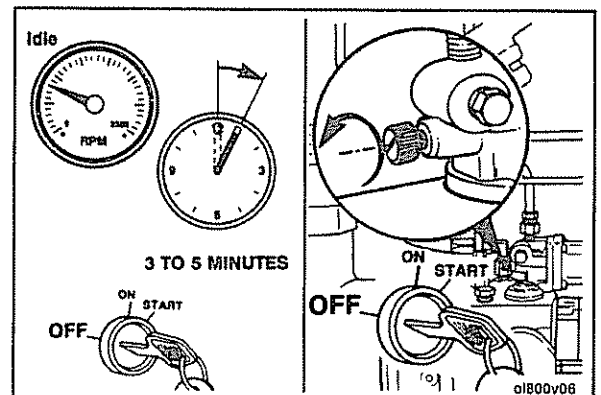

PTO Application with Variable Speed

The variable speed governor on power takeoff applications is used to control engine speed at the desired RPM.

To engage the variable speed governor with the engine idling on standard throttle:

1. Put the variable speed control lever (1) in the idle position,
2. Lock the standard throttle lever (2) in the full open position,
3. Adjust the variable speed control lever (1) to the speed desired.

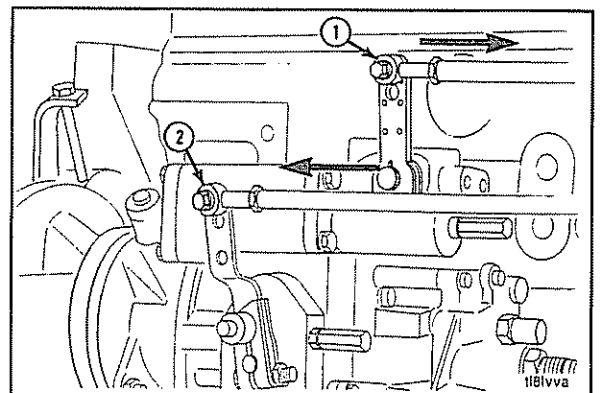

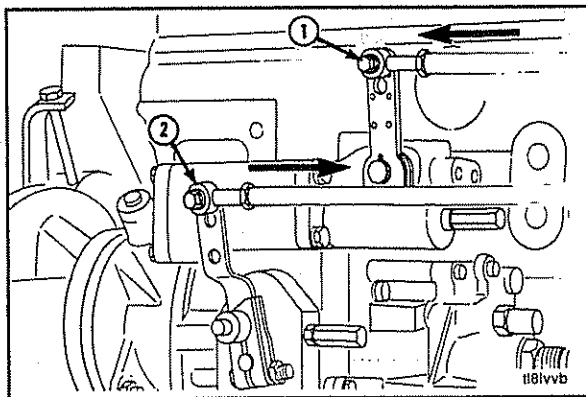

To return to standard throttle operation:

1. Return the standard throttle (2) to the idle position,
2. Lock the variable speed control lever (1) in the maximum speed position.

Section 2 - Maintenance Guidelines

Section Contents

	Page
Maintenance Guidelines - General Information	2-1
Maintenance Record Form	2-5
Maintenance Schedule	2-2
Page References for Maintenance Instructions	2-3
Tool Requirements	2-1

THIS PAGE LEFT INTENTIONALLY BLANK.

Maintenance Guidelines - General Information

Cummins Engine Company, Inc. recommends that the engine be maintained according to the Maintenance Schedule in this section.

If the engine is operating in ambient temperatures consistently below -18°C [0°F] or above 38°C [100°F], perform maintenance at shorter intervals. Shorter maintenance intervals are also required if the engine is operated in a dusty environment. See your Cummins Authorized Repair Location for recommended intervals.

Some of these maintenance procedures require special tools, or **must** be done by qualified personnel. These procedures are outlined in the specific manuals as follows:

Procedure	Bulletin No.	Description
Clean and calibrate the injectors	3810344	PT (Type D) Top Stop Injector Shop Manual
Clean and calibrate the fuel pump	3379084	Fuel Pump (PT Type G) Rebuild and Calibrate
Repair and rebuild components	3666075	Shop Manual, M11 Series Engines

If your engine is equipped with a component or an accessory **not** manufactured by Cummins Engine Company, Inc., refer to the component manufacturer's maintenance recommendations. A listing of supplier's addresses and telephone numbers is provided in Component Manufacturers (Section M).

Use the chart provided at the end of this section as a convenient way to keep a record of maintenance performed.

Tool Requirements

Most of the maintenance operations described in this manual can be performed with common hand tools (metric and S.A.E. wrenches, sockets, and screwdrivers).

The following is a list of special service tools required for some maintenance operations:

Tool Part No.	Description
3375044	Torque Wrench Kit (Torque Wrench and Screwdriver Adapter)
3375049	Oil Filter Wrench
3376592	Torque Wrench (Valve and Injector Adjustment)
3823024	Injector Puller
3376807	Engine Coolant and Fuel Filter Wrench
3822524	Belt Tension Gauge, Click Type (v-belts and v-ribbed with 4 or 5 ribs)
3822525	Belt Tension Gauge, Click Type (v-ribbed with 6 to 12 ribs)
ST-537	Dial Depth Gauge
ST-669	Torque Wrench Adapter (Used with 3376592 Torque Wrench)
ST-1138	Belt Tension Gauge (v-belts)
ST-1225	Thermostat Seal Mandrel
ST-1272-11	Chip Removing Tool
ST-1293	Belt Tension Gauge (v-ribbed belts)

Contact your nearest Cummins Authorized Repair Location for the required service tools.

Maintenance Schedule

M11 Industrial Engine Maintenance Schedule ^{(1), (3)}					
Daily or Refueling	Weekly ⁽³⁾	Every 250 Hours or 6 Months ^{(2),(3),(4)}	Every 1500 Hours ⁽³⁾	Every 6000 Hours or 2 Years ⁽³⁾	Every 6000 Hours ⁽³⁾
Check	Check	Change	Adjust	Clean	Clean and Calibrate
<ul style="list-style-type: none"> • Operator's report • Engine oil level • Coolant level 	<ul style="list-style-type: none"> • Air intake system for wear points or damage to piping, loose clamps, and leaks • Air cleaner restriction 	<ul style="list-style-type: none"> • Lubricating oil • Lubricating oil filter • Fuel filter • Coolant filter 	<ul style="list-style-type: none"> • Valves and injectors 	<ul style="list-style-type: none"> • Cooling system 	<ul style="list-style-type: none"> • Injectors • Fuel pump
Visually Inspect	Check and Clean	Replace	Check	Change	Inspect
<ul style="list-style-type: none"> • Cooling Fan • Engine for damage, leaks, and loose chunked or frayed belts • Crankcase breather tube 	<ul style="list-style-type: none"> • Air cleaner element 	<ul style="list-style-type: none"> • Element on Cummins two cylinder air compressor, if equipped with an air cleaner 	<ul style="list-style-type: none"> • Torque on turbocharger mounting nuts • Torque on engine mounting bolts • Shutterstats and thermatic fans (if equipped) 	<ul style="list-style-type: none"> • Heavy duty coolant 	<ul style="list-style-type: none"> • Turbocharger • Air compressor • Fan hub • Fan idler pulley assembly • Vibration damper
Drain	Drain	Check	Inspect		
<ul style="list-style-type: none"> • Fuel-water separator 	<ul style="list-style-type: none"> • Moisture from air tanks 	<ul style="list-style-type: none"> • Engine coolant SCA concentration level 	<ul style="list-style-type: none"> • Water pump 		
			Clean		
			<ul style="list-style-type: none"> • Water pump weep hole 		

NOTE: Refer to the appropriate sections for complete inspection and maintenance procedures.

1. Follow the equipment manufacturer's recommended maintenance procedures for all non-Cummins manufactured engine accessories. Common accessories include: air compressor, alternator, batteries and electrical components, engine brake, exhaust brake, fan clutch, freon compressor, and starter. Refer to Section M for addresses and telephone numbers.
2. For standby generator applications, the recommended oil change interval is 250 hours or 12 months, whichever comes first.
3. These maintenance intervals **must** be performed at hours or months, whichever occurs first. At each scheduled maintenance interval, perform ALL previous maintenance procedures which are due for scheduled maintenance.
4. **Do not** change the coolant filter if the SCA concentration level is over 3 units.

Page References for Maintenance Instructions

For your convenience, listed below are the page numbers which contain specific instructions for performing the maintenance checks listed in the maintenance schedule.

Daily or Refueling

Drive belts - inspect	3-5
Lubricating oil level - check	3-2
Coolant level - check	3-2
Cooling fan - inspect	3-4
Fuel-water separator - drain	3-2
Crankcase breather tube (ice buildup) - visual check	3-5

Weekly

Air intake system - visual check	4-5
Air cleaner restriction - check	4-1
Air cleaner element - check	4-1
Air tanks and resevoirs - drain	4-7

Every 250 Hours or 6 Months

Lubricating oil - change	5-2
Lubricating oil filters - change	5-2
Fuel filter - change	5-1
Coolant filter - change	5-7
Air compressor air cleaner element - replace	5-9
Supplemental Coolant Additive Concentration (SCA) - check	5-8

Every 1,500 Hours

Valves and injectors - adjust	6-1
Turbocharger mounting nuts - check torque	6-8
Engine mounting bolts - check torque	6-9
Shutters and thermatic fan (if equipped) - check	6-8
Water pump - inspect	6-7
Engine - steam clean	6-9

Every 6,000 Hours or 2 Years

Cooling system - clean	7-1
Coolant and anti-freeze - change	7-1

Every 6,000 Hours

Injectors - clean and calibrate	8-1
Fuel pump - clean and calibrate	8-5
Turbocharger - inspect	8-9
Air compressor - inspect	8-11
Fan hub - inspect	8-9
Fan idler pulley assembly - inspect	8-8
Vibration damper - inspect	8-1

Section 3 - Maintenance Procedures at Daily Interval

Section Contents

	Page
Coolant Level	3-2
Maintenance Check	3-2
Crankcase Breather Tube	3-5
Maintenance Check	3-5
Daily Maintenance Procedures - General Information	3-1
Drive Belts	3-5
Maintenance Check	3-5
Engine Operation Report	3-1
Fan, Cooling	3-4
Inspect for Reuse	3-4
Fuel-Water Separator	3-2
Drain	3-2
Lubricating Oil Level	3-2
Maintenance Check	3-2

THIS PAGE LEFT INTENTIONALLY BLANK.

Daily Maintenance Procedures - General Information

Good maintenance begins with day-to-day awareness of the engine and its system.

Before starting the engine, check the oil and coolant levels. Look for:

- Leaks
- Loose or damaged parts
- Worn or damaged belts
- Any change in engine appearance

Engine Operation Report

The engine **must** be maintained in top mechanical condition if the operator is to get optimum satisfaction from its use. The maintenance department needs daily running reports from the operator to make necessary adjustments in the time allocated and to make provisions for more extensive maintenance work as the reports indicate the necessity.

Comparison and intelligent interpretation of the daily report along with a practical follow-up action will eliminate most failures and emergency repairs.

Report to the Maintenance Department any of the following conditions:

- Low lubricating oil pressure
- Low power
- Abnormal water or oil temperature
- Unusual engine noise
- Excessive smoke
- Excessive use of coolant, fuel, or lubricating oil
- Any fuel, coolant, or lubricating oil leaks

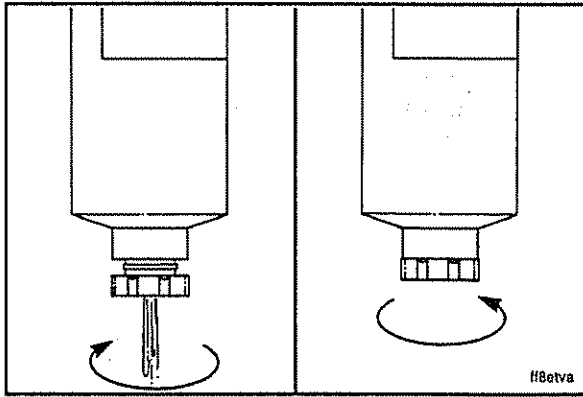

Fuel-Water Separator

Drain

Cummins Engine Company, Inc. requires a fuel-water separator to be installed in the fuel supply system. Drain the water and sediment from the separator daily.

Shut off the engine. Use your hand to open the drain valve. Turn the valve **counterclockwise** approximately 1 1/2 to 2 turns until draining occurs. Drain the filter sump of water until clear fuel is visible.

When closing the drain valve, do **not** overtighten the valve. Overtightening can damage the threads. Turn the valve **clockwise** to close the drain valve.

Dispose of the drained water in accordance with local environmental regulations.

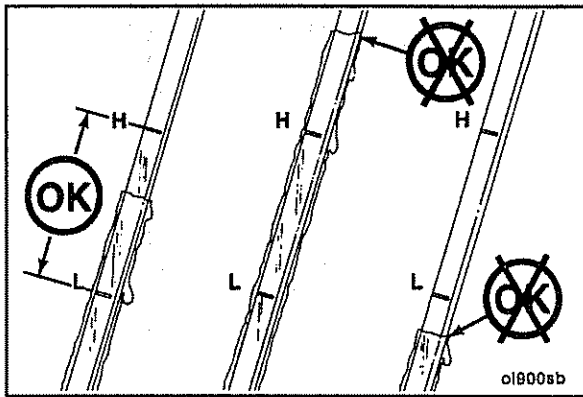

Lubricating Oil Level

Maintenance Check

The engine **must** be level when checking the oil level to make sure the measurement is correct.

Check the oil level daily.

Never operate the engine with the oil level below the "L" (Low) mark, or above the "H" (High) mark. Wait at least five minutes after shutting off the engine to check the oil level. This allows time for the oil to drain to the oil pan.

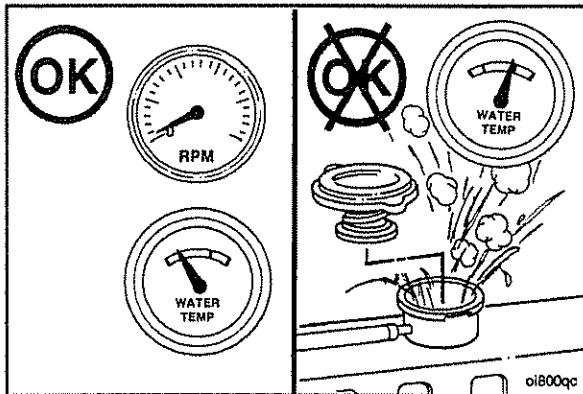

Coolant Level

Maintenance Check

▲ WARNING ▲

Do not remove the radiator cap from a hot engine. Wait until the temperature is below 50°C [120°F] before removing the pressure cap. Failure to do so can result in personal injury from heated coolant spray or steam. Remove the filler cap slowly to relieve coolant system pressure.

Never use a sealing additive to stop leaks in the cooling system. This can result in cooling system plugging and inadequate coolant flow causing the engine to overheat.

The coolant level **must** be checked daily.

⚠ CAUTION ⚠

Do not add cold coolant to a hot engine. Engine castings can be damaged. Allow the engine to cool to below 50°C [120°F] before adding coolant.

Cummins Engine Company, Inc. recommends using either a 50/50 mixture of good quality water and fully formulated antifreeze, or fully formulated coolant when filling the cooling system. The fully formulated antifreeze or coolant **must** meet TMC RP 329 or TMC RP 330 specifications. Refer to Coolant Recommendations and Specifications in Section V.

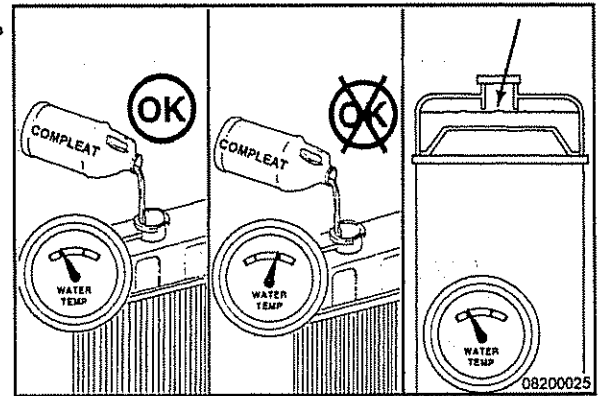

Fully formulated antifreeze **must** be mixed with good quality water at a 50/50 ratio (40 to 60% working range). A 50/50 mixture of antifreeze and water gives a -36°C [-34°F] freeze point and a boiling point of 110°C [228°F], which is adequate for locations in North America. The actual lowest freeze point of ethylene glycol antifreeze is at 68%. Using higher concentrations of antifreeze will raise the freeze point of the solution and increase the possibility of a silicate gel problem.

Use ethylene glycol antifreeze year-round to provide freeze point and boil-over protection.

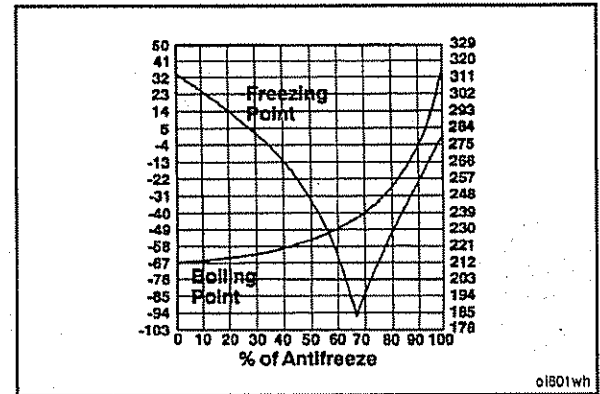

The Fleetguard® refractometer, Part No. CC2800, **must** be used to accurately measure the freeze point of the coolant.

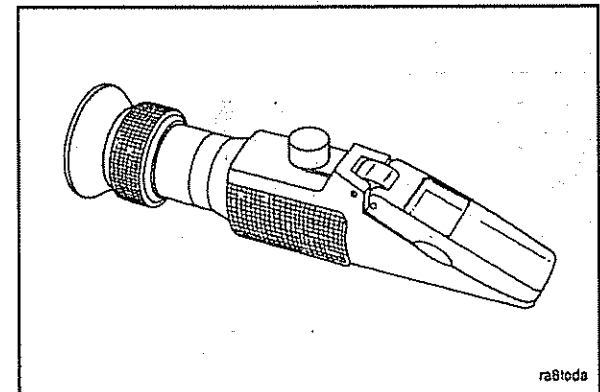

Fill the cooling system with coolant to the bottom of the fill neck in the radiator fill or expansion tank.

NOTE: Some radiators have two fill necks, both of which **must** be filled when the cooling system is drained.

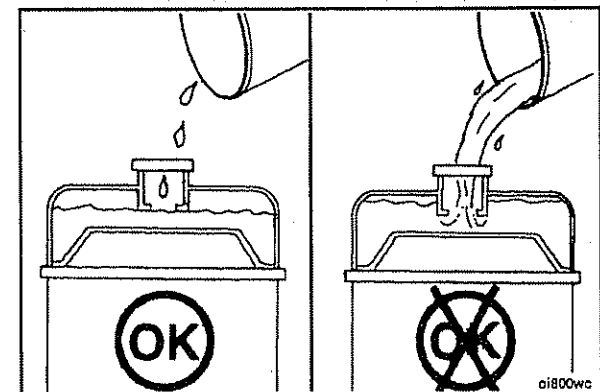

Fan, Cooling

Inspect for Reuse

▲ WARNING ▲

Do not rotate the engine by pulling or prying on the fan. The fan blade(s) can be damaged and cause the fan to fail and cause serious personal injury or property damage. Use the accessory drive shaft to rotate the crankshaft.

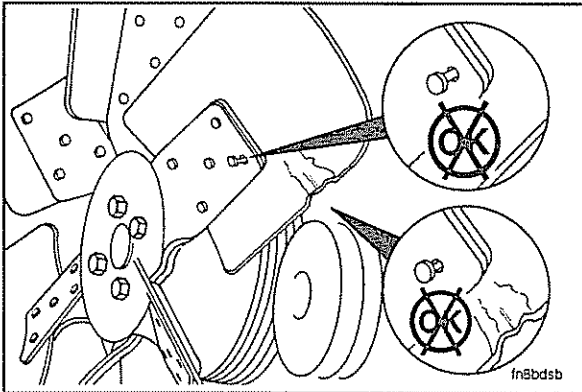
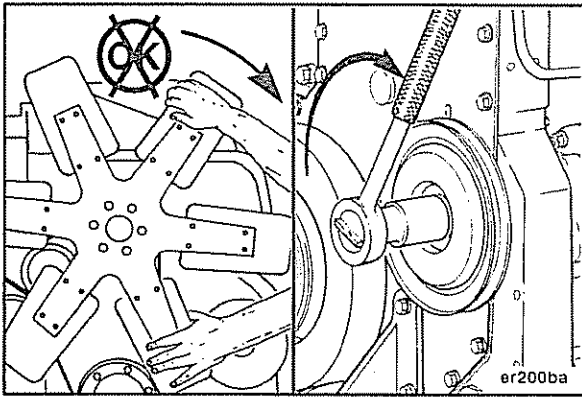

A visual inspection of the cooling fan is required daily. Check for cracks, loose rivets, and bent or loose blades. Check the fan to make sure it is securely mounted. Tighten the capscrews if necessary.

▲ WARNING ▲

Do not straighten a bent fan blade, or continue to use a damaged fan. A bent or damaged fan blade can fail during operation and cause serious personal injury or property damage.

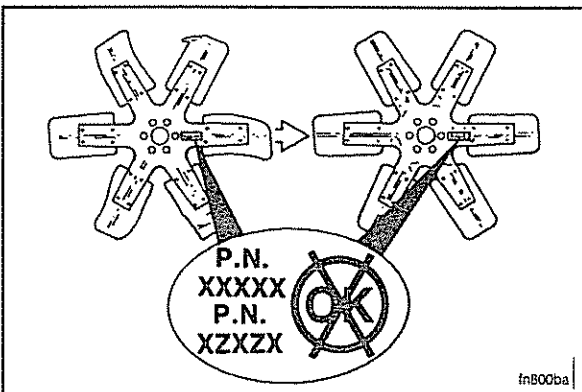
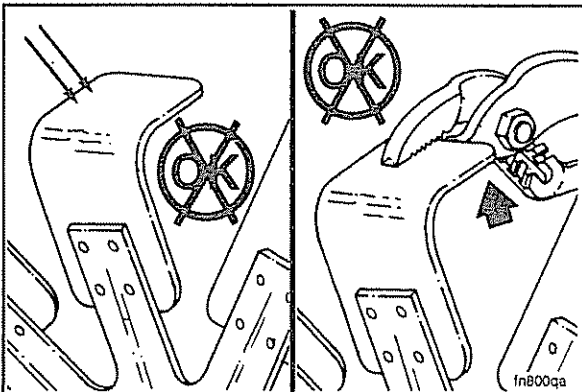

Replace any original equipment fan that is damaged with a fan of the identical part number. Cummins Engine Company, Inc. must approve any other fan changes.

Drive Belts

Maintenance Check

Visually inspect the belts daily. Replace the belt if it is frayed or has chunks of material missing. Small cracks are acceptable. Adjust belts that have a glazed or shiny surface which indicates belt slippage. Correctly installed and tensioned belts will show even pulley and belt wear. Refer to Section A for belt adjustment and replacement procedures.

Belt damage can be caused by:

- Incorrect tension
- Incorrect size or length
- Pulley misalignment
- Incorrect installation
- Severe operating environment
- Oil or grease on the belts

Measure the belt tension in the center span of the pulleys.

Refer to the Belt Tension Chart, Section V, for the correct gauge and tension value for the belt width used.

An alternate method (deflection) can be used to check belt tension by applying 110 N [25 lbf] between the pulleys on v-belts. If the deflection is more than one (1) belt thickness per foot of pulley center distance, the belt tension **must** be adjusted.

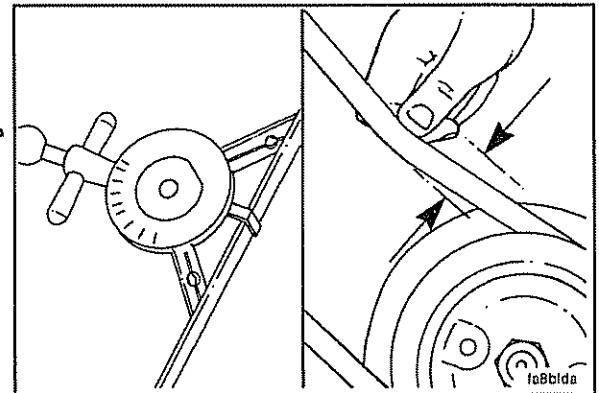
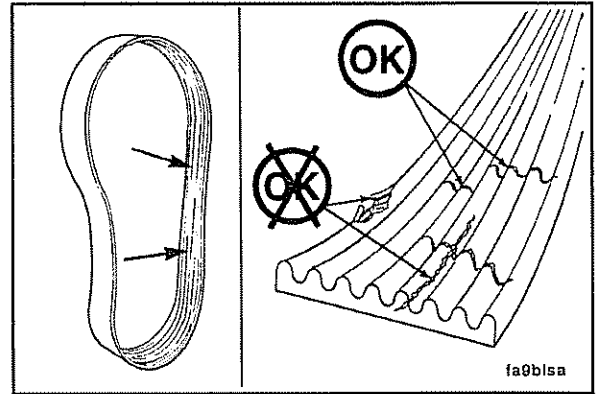

Crankcase Breather Tube

Maintenance Check

Check the crankcase breather tube daily during cold weather operations for ice buildup which could obstruct the tube.

If an ice buildup is present, remove the breather tube, if necessary, and clear the obstruction.

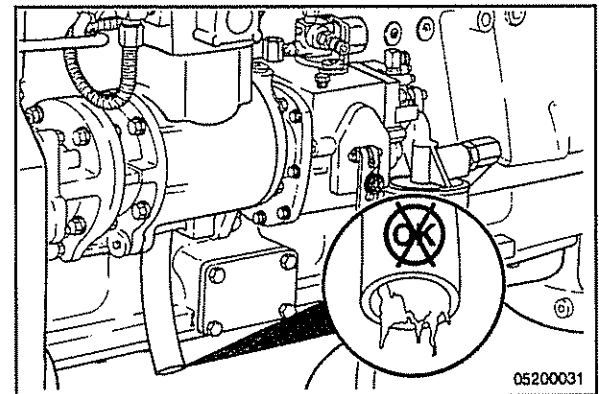

Maintenance Procedures at Weekly Interval

Section Contents

	Page
Air Cleaner Element, Cartridge Type	4-4
Maintenance Check	4-4
Air Cleaner Element, Dual Heavy Duty Dry Type	4-3
Maintenance Check	4-3
Air Cleaner Element, Paper Type	4-1
Maintenance Check.....	4-1
Air Cleaner Element, Single Heavy Duty Dry Type	4-2
Maintenance Check	4-2
Air Cleaner Restriction	4-1
Maintenance Check	4-1
Air Leaks, Air Intake System	4-5
Maintenance Check.....	4-5
Air Tanks and Reservoirs	4-7
Drain	4-7
Weekly Maintenance Procedures - General Information	4-1

THIS PAGE LEFT INTENTIONALLY BLANK.

Weekly Maintenance Procedures - General Information

All checks or inspections listed under the daily maintenance interval **must** also be performed at this time in addition to those listed under this maintenance interval.

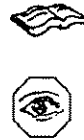

M11 Engine Maintenance Schedule					
Check	Interval	Every 100 Hours or 8 Months	Every 1000 Hours	Every 2000 Hours or 1 Year	Every 4000 Hours
Check	Check	Change	Adjust	Check	Check and Change
<ul style="list-style-type: none"> 1. Check oil level 2. Check air filter 3. Check water level 4. Check battery 5. Check fan belt 6. Check drive belt 7. Check generator belt 	<ul style="list-style-type: none"> 1. Air filter restriction 2. Air filter element 3. Air filter housing 4. Air filter indicator 	<ul style="list-style-type: none"> 1. Lubricating oil 2. Lubricating oil filter 3. Coolant level 	<ul style="list-style-type: none"> 1. Valve and piston 	<ul style="list-style-type: none"> 1. Cooling system 	<ul style="list-style-type: none"> 1. Piston and cylinder 2. Fuel pump
Weekly Interval	Check and Change	Replace	Check	Change	Inspect
<ul style="list-style-type: none"> 1. Check fan belt 2. Check drive belt 3. Check generator belt 4. Check water level 5. Check battery 6. Check oil level 7. Check air filter 8. Check air filter indicator 	<ul style="list-style-type: none"> 1. Air filter element 	<ul style="list-style-type: none"> 1. Lubricating oil 2. Lubricating oil filter 3. Coolant level 4. Coolant filter 5. Coolant pump 6. Coolant hose 7. Coolant hose clamp 8. Coolant hose bracket 9. Coolant hose support 10. Coolant hose clamp 11. Coolant hose clamp 12. Coolant hose clamp 13. Coolant hose clamp 14. Coolant hose clamp 15. Coolant hose clamp 16. Coolant hose clamp 17. Coolant hose clamp 18. Coolant hose clamp 19. Coolant hose clamp 20. Coolant hose clamp 21. Coolant hose clamp 22. Coolant hose clamp 23. Coolant hose clamp 24. Coolant hose clamp 25. Coolant hose clamp 26. Coolant hose clamp 27. Coolant hose clamp 28. Coolant hose clamp 29. Coolant hose clamp 30. Coolant hose clamp 31. Coolant hose clamp 32. Coolant hose clamp 33. Coolant hose clamp 34. Coolant hose clamp 35. Coolant hose clamp 36. Coolant hose clamp 37. Coolant hose clamp 38. Coolant hose clamp 39. Coolant hose clamp 40. Coolant hose clamp 41. Coolant hose clamp 42. Coolant hose clamp 43. Coolant hose clamp 44. Coolant hose clamp 45. Coolant hose clamp 46. Coolant hose clamp 47. Coolant hose clamp 48. Coolant hose clamp 49. Coolant hose clamp 50. Coolant hose clamp 51. Coolant hose clamp 52. Coolant hose clamp 53. Coolant hose clamp 54. Coolant hose clamp 55. Coolant hose clamp 56. Coolant hose clamp 57. Coolant hose clamp 58. Coolant hose clamp 59. Coolant hose clamp 60. Coolant hose clamp 61. Coolant hose clamp 62. Coolant hose clamp 63. Coolant hose clamp 64. Coolant hose clamp 65. Coolant hose clamp 66. Coolant hose clamp 67. Coolant hose clamp 68. Coolant hose clamp 69. Coolant hose clamp 70. Coolant hose clamp 71. Coolant hose clamp 72. Coolant hose clamp 73. Coolant hose clamp 74. Coolant hose clamp 75. Coolant hose clamp 76. Coolant hose clamp 77. Coolant hose clamp 78. Coolant hose clamp 79. Coolant hose clamp 80. Coolant hose clamp 81. Coolant hose clamp 82. Coolant hose clamp 83. Coolant hose clamp 84. Coolant hose clamp 85. Coolant hose clamp 86. Coolant hose clamp 87. Coolant hose clamp 88. Coolant hose clamp 89. Coolant hose clamp 90. Coolant hose clamp 91. Coolant hose clamp 92. Coolant hose clamp 93. Coolant hose clamp 94. Coolant hose clamp 95. Coolant hose clamp 96. Coolant hose clamp 97. Coolant hose clamp 98. Coolant hose clamp 99. Coolant hose clamp 100. Coolant hose clamp 	<ul style="list-style-type: none"> 1. Lubricating oil 2. Lubricating oil filter 3. Coolant level 4. Coolant filter 5. Coolant pump 6. Coolant hose 7. Coolant hose clamp 8. Coolant hose bracket 9. Coolant hose support 10. Coolant hose clamp 11. Coolant hose clamp 12. Coolant hose clamp 13. Coolant hose clamp 14. Coolant hose clamp 15. Coolant hose clamp 16. Coolant hose clamp 17. Coolant hose clamp 18. Coolant hose clamp 19. Coolant hose clamp 20. Coolant hose clamp 21. Coolant hose clamp 22. Coolant hose clamp 23. Coolant hose clamp 24. Coolant hose clamp 25. Coolant hose clamp 26. Coolant hose clamp 27. Coolant hose clamp 28. Coolant hose clamp 29. Coolant hose clamp 30. Coolant hose clamp 31. Coolant hose clamp 32. Coolant hose clamp 33. Coolant hose clamp 34. Coolant hose clamp 35. Coolant hose clamp 36. Coolant hose clamp 37. Coolant hose clamp 38. Coolant hose clamp 39. Coolant hose clamp 40. Coolant hose clamp 41. Coolant hose clamp 42. Coolant hose clamp 43. Coolant hose clamp 44. Coolant hose clamp 45. Coolant hose clamp 46. Coolant hose clamp 47. Coolant hose clamp 48. Coolant hose clamp 49. Coolant hose clamp 50. Coolant hose clamp 51. Coolant hose clamp 52. Coolant hose clamp 53. Coolant hose clamp 54. Coolant hose clamp 55. Coolant hose clamp 56. Coolant hose clamp 57. Coolant hose clamp 58. Coolant hose clamp 59. Coolant hose clamp 60. Coolant hose clamp 61. Coolant hose clamp 62. Coolant hose clamp 63. Coolant hose clamp 64. Coolant hose clamp 65. Coolant hose clamp 66. Coolant hose clamp 67. Coolant hose clamp 68. Coolant hose clamp 69. Coolant hose clamp 70. Coolant hose clamp 71. Coolant hose clamp 72. Coolant hose clamp 73. Coolant hose clamp 74. Coolant hose clamp 75. Coolant hose clamp 76. Coolant hose clamp 77. Coolant hose clamp 78. Coolant hose clamp 79. Coolant hose clamp 80. Coolant hose clamp 81. Coolant hose clamp 82. Coolant hose clamp 83. Coolant hose clamp 84. Coolant hose clamp 85. Coolant hose clamp 86. Coolant hose clamp 87. Coolant hose clamp 88. Coolant hose clamp 89. Coolant hose clamp 90. Coolant hose clamp 91. Coolant hose clamp 92. Coolant hose clamp 93. Coolant hose clamp 94. Coolant hose clamp 95. Coolant hose clamp 96. Coolant hose clamp 97. Coolant hose clamp 98. Coolant hose clamp 99. Coolant hose clamp 100. Coolant hose clamp 	<ul style="list-style-type: none"> 1. Water pump 2. Water pump bracket 3. Water pump clamp 4. Water pump support 5. Water pump clamp 6. Water pump clamp 7. Water pump clamp 8. Water pump clamp 9. Water pump clamp 10. Water pump clamp 11. Water pump clamp 12. Water pump clamp 13. Water pump clamp 14. Water pump clamp 15. Water pump clamp 16. Water pump clamp 17. Water pump clamp 18. Water pump clamp 19. Water pump clamp 20. Water pump clamp 21. Water pump clamp 22. Water pump clamp 23. Water pump clamp 24. Water pump clamp 25. Water pump clamp 26. Water pump clamp 27. Water pump clamp 28. Water pump clamp 29. Water pump clamp 30. Water pump clamp 31. Water pump clamp 32. Water pump clamp 33. Water pump clamp 34. Water pump clamp 35. Water pump clamp 36. Water pump clamp 37. Water pump clamp 38. Water pump clamp 39. Water pump clamp 40. Water pump clamp 41. Water pump clamp 42. Water pump clamp 43. Water pump clamp 44. Water pump clamp 45. Water pump clamp 46. Water pump clamp 47. Water pump clamp 48. Water pump clamp 49. Water pump clamp 50. Water pump clamp 51. Water pump clamp 52. Water pump clamp 53. Water pump clamp 54. Water pump clamp 55. Water pump clamp 56. Water pump clamp 57. Water pump clamp 58. Water pump clamp 59. Water pump clamp 60. Water pump clamp 61. Water pump clamp 62. Water pump clamp 63. Water pump clamp 64. Water pump clamp 65. Water pump clamp 66. Water pump clamp 67. Water pump clamp 68. Water pump clamp 69. Water pump clamp 70. Water pump clamp 71. Water pump clamp 72. Water pump clamp 73. Water pump clamp 74. Water pump clamp 75. Water pump clamp 76. Water pump clamp 77. Water pump clamp 78. Water pump clamp 79. Water pump clamp 80. Water pump clamp 81. Water pump clamp 82. Water pump clamp 83. Water pump clamp 84. Water pump clamp 85. Water pump clamp 86. Water pump clamp 87. Water pump clamp 88. Water pump clamp 89. Water pump clamp 90. Water pump clamp 91. Water pump clamp 92. Water pump clamp 93. Water pump clamp 94. Water pump clamp 95. Water pump clamp 96. Water pump clamp 97. Water pump clamp 98. Water pump clamp 99. Water pump clamp 100. Water pump clamp 	

NOTE: Refer to the appropriate sections for service inspection and maintenance procedures.

- Follow the manufacturer's instructions for component maintenance procedures for all non-Case/Cummins parts. Do not use any other parts or accessories unless they are specifically approved for use with this engine and alternator.
- For specific component applications, the recommended oil change interval is 100 hours or 12 months, whichever comes first.
- These maintenance intervals must be performed at least at 100 hours or 12 months, whichever comes first. At each interval use appropriate materials, perform all (1) specified maintenance procedures which are listed for scheduled maintenance.
- Do not change the coolant level if the RCL (coolant level) is only 1 unit.

00200018

Air Cleaner Restriction Maintenance Check

Once a week check the air cleaner restriction. Maximum intake air restriction is 635 mm H₂O [25 in H₂O].

Never operate the engine without an air cleaner. Intake air **must** be filtered to prevent dirt and debris from entering the engine and causing premature wear. Follow the filter manufacturer's instructions when cleaning or replacing the air cleaner element.

Check the air cleaner service indicator, if equipped. Change the filter element when the red indicator flag (2) is at the raised position in the window (1). After the air cleaner has been serviced, reset the button (3) in the end of the service indicator.

Vacuum switches actuate a warning light on the instrument panel when the air restriction becomes excessive.

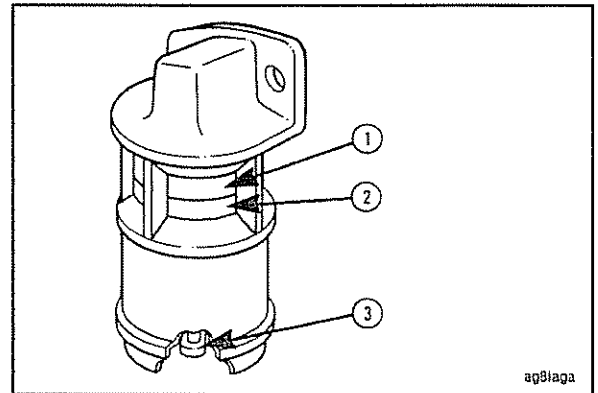

Air Cleaner Element, Paper Type Maintenance Check

NOTE: The illustrations in this section show typical parts. The particular engine parts can vary.

The paper element (6) in a dry-type air cleaner can be cleaned several times by using compressed air to remove the dirt, approximately 207 kPa [30 psi]. Do **not** hold the air jet too close to the paper element when cleaning.

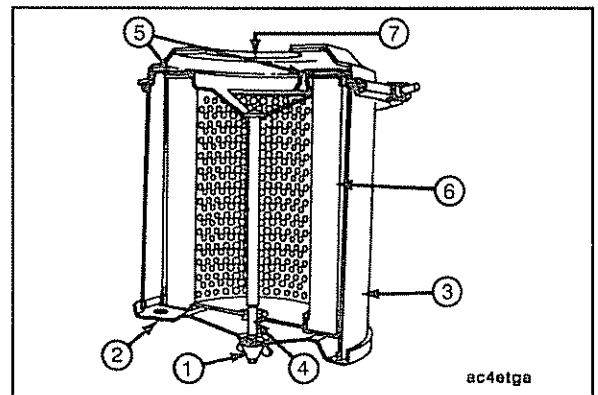

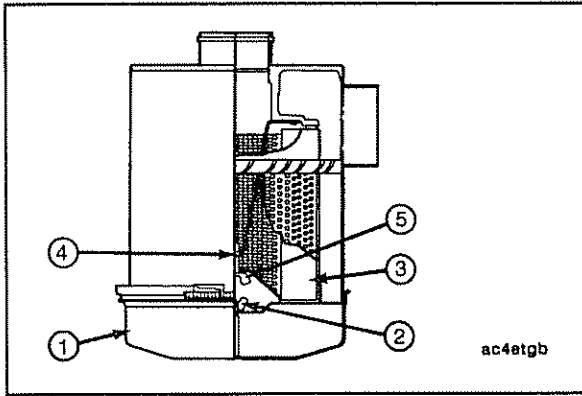

△ CAUTION △

Holes, loose end seals, dented sealing surfaces, and other forms of damage render the cleaner inoperative and require immediate element replacement.

Elements that have been cleaned several times will finally clog and air flow to the engine will be restricted. After cleaning the element, check the restriction as previously described. Replace the element if necessary.

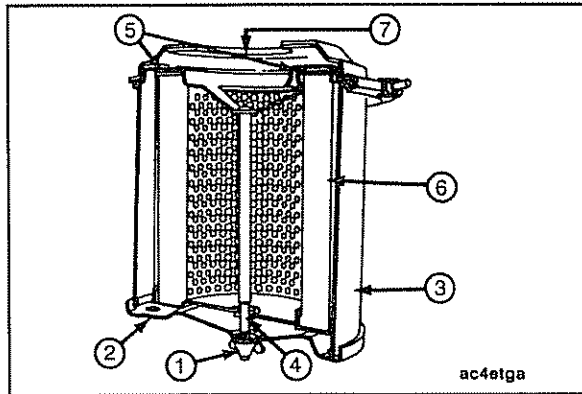

△ CAUTION △

Pull the cover and the element straight out when removing them from the housing to avoid damage to the element.

Remove the wing nut (1) that secures the bottom cover (2) to the cleaner housing (3). Remove the cover.

Pull the element (6) down from the center bolt (4).

Remove the gasket (5) from the outlet end (7) of the housing.

Install the element in the reverse order.

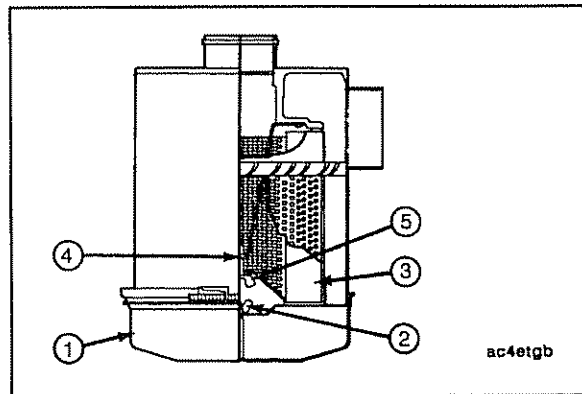

Air Cleaner Element, Single Heavy Duty Dry Type

Maintenance Check

Heavy duty air cleaners combine centrifugal cleaning with element filtering before air enters the engines.

Before disassembly, wipe dirt from the cover and the upper portion of the air cleaner.

To clean the single types, loosen the wing bolt and remove the band securing the dust pan (1).

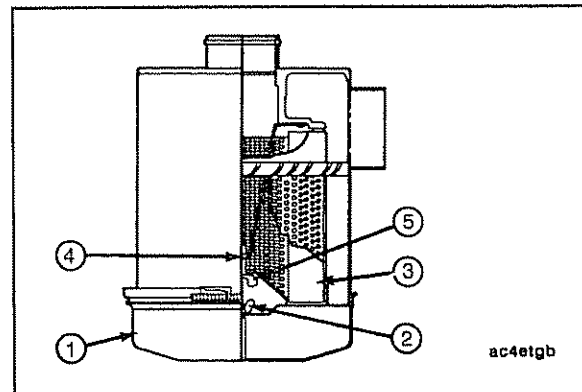

Loosen the wing nut (2). Remove the dust shield (3) from the dust pan (1). Clean the dust pan and shield.



Remove the wing nut (5) and secure the air cleaner primary element in the air cleaner housing. Inspect the rubber sealing washer on the wing nut (4).



Clean the element from the clean air side with compressed air **not** exceeding 207 kPa [30 psi]. Inspect the element after cleaning. Install the cleaned primary element or a new element.

Make sure the gasket washer is in place under the wing nut before tightening.

Assemble the dust shield and dust pan again. Position them to the air cleaner housing and secure with the band.

Air Cleaner Element, Dual Heavy Duty Dry Type

Maintenance Check

Heavy duty air cleaners combine centrifugal cleaning with element filtering before air enters the engines.

Before disassembly, wipe dirt from the cover and the upper portion of the air cleaner.

To clean the dual types, loosen the wing bolt (1) and remove the band securing the dust pan (2).

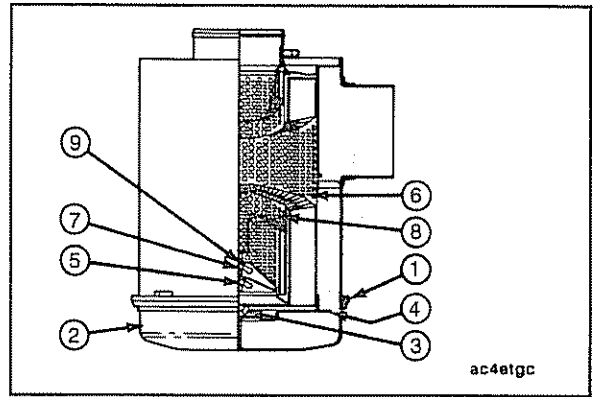

Loosen the wing nut (3). Remove the dust shield (4) from the dust pan (2). Clean the dust pan and shield.

Remove the wing nut (5) and secure the air cleaner primary element (6) in the air cleaner housing. Inspect the rubber sealing washer on the wing nut (9).

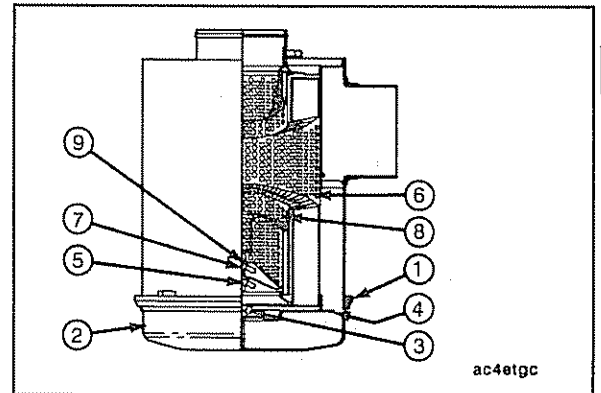

Clean the element from the clean air side with compressed air **not** exceeding 207 kPa [30 psi]. Inspect the element after cleaning. Install the cleaned primary element or a new element.

Make sure the gasket washer is in place under the wing nut before tightening.

Assemble the dust shield and dust pan again. Position them to the air cleaner housing and secure with the band.

On the dual element type Cyclopac cleaner, check the air restriction indicator. If the air restriction is excessive, disassemble the air cleaner. Remove the wing nut (7) and replace the safety element (8).

Assemble the air cleaner as described above.

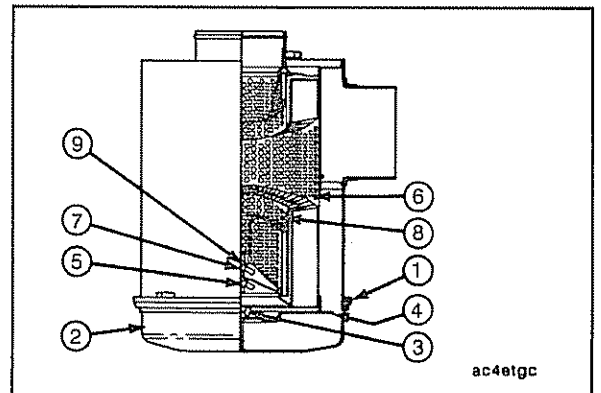

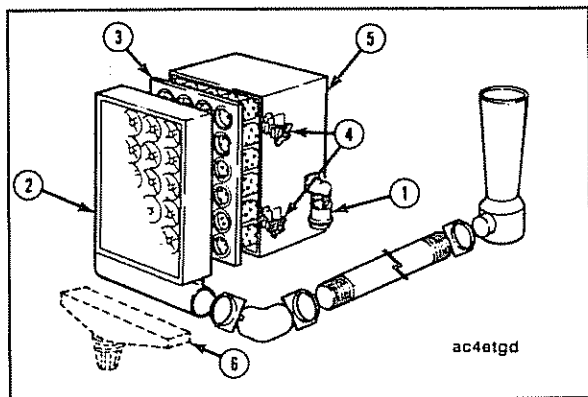

Air Cleaner Element, Cartridge Type Maintenance Check

Loosen the wing nuts (4) on the air cleaner housing (5) to remove the pre-cleaner panel with the dust bin (6). To remove the pre-cleaner panel (2) equipped with an exhaust aspirator, loosen the u-bolt clamp securing the pre-cleaner to the aspirator tubing.

Remove the dirty Pamic cartridge (3) by inserting your fingers in the cartridge opening (loosen all four corners of the cartridge, one at a time) and pulling it straight out.

With the larger cartridge, it can be necessary to break the seal along the edges of the cartridge. After the seal has been broken, pull the cartridge straight out and slightly up so the cartridge will clear the sealing frame and edges of the air cleaner housing.

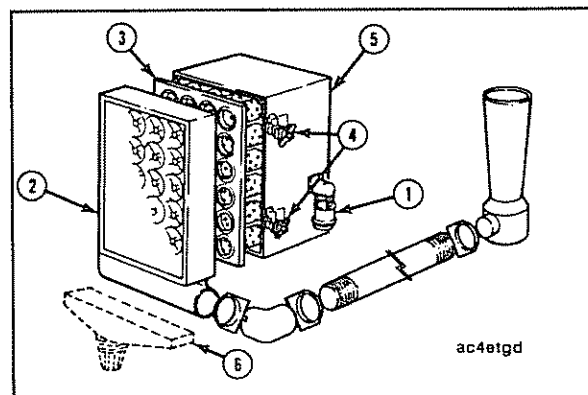

Clean the pre-cleaner openings (2) of all soot, oil film, and any other objects that can become lodged in the openings. Remove any dust or dirt in the lower portion of the pre-cleaner and aspirator tubing. Inspect the inside of the air cleaner housing for foreign material.



Inspect the dirty cartridge for soot or oil. If there is soot inside the Pamic tubes, check for leaks in the engine exhaust system, exhaust blow-back into the air intake, and exhaust from other equipment. If the cartridge appears oily, check for fumes escaping from the crankcase breather. Excessive oil mist shortens the life of any dry-type cartridge. Troubleshooting at this point can appreciably lengthen new cartridge life.

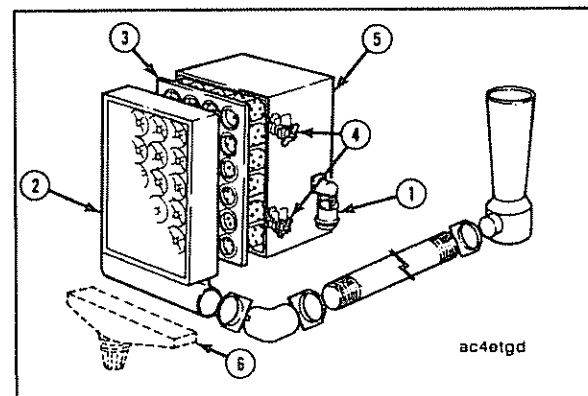

It is **not** recommended to clean and reuse the cartridge. When returned to service, life expectancy of a cleaned cartridge will be only a fraction of the original service life.

Inspect clamps and flexible hose or tubing to make sure all fittings are air tight on cleaners with exhaust aspirators.

The pre-cleaner dust bin (6) is self-cleaning.

M11 Maintenance Procedures at Weekly Interval

Inspect the new filter cartridge for shipping damage before installing the filter.

To install a new cartridge, hold the cartridge (3) in the same manner as when removing it from the housing. Insert the clean cartridge into the housing. Avoid hitting the cartridge tubes against the sealing flange on the edges of the air cleaner housing.

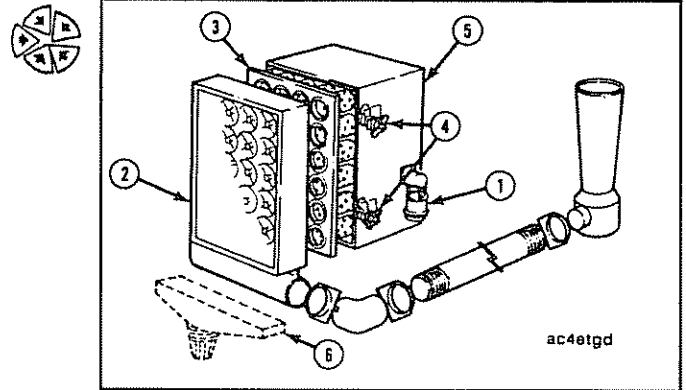

As the cleaner requires no separate gaskets for seals, care **must** be taken when inserting the cartridge to make certain it is properly seated within the cleaner housing. Firmly press all edges and corners of the cartridge with your fingers to effect a positive air seal against the sealing flange of the housing. The cartridge **must not** be pounded or pressed in the center to seal.

Replace the pre-cleaner panel (2) and tighten the wing nuts (4) by hand. For final tightness, turn the wing nuts 1 to 1-1/2 turns with a small adjustable wrench. Do **not** tighten too much. On a pre-cleaner with an exhaust aspirator, assemble the aspirator tube to the pre-cleaner panel and tighten the u-bolt.

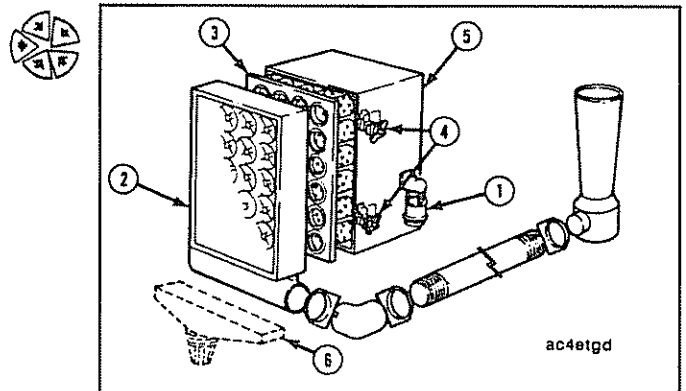

Care **must** be taken to keep the cleaner face unobstructed.

Reset the mechanical inlet air restriction indicator.

Air Leaks, Air Intake System

Maintenance Check

⚠ CAUTION ⚠

Engine intake air must be filtered to prevent dirt and debris from entering the engine. If intake air piping is damaged or loose, unfiltered air will enter the engine and cause premature wear.

Inspect the intake air piping once a week for cracked hoses, damage, or loose clamps.

Replace damaged pipes and tighten loose clamps as necessary to make sure the air intake system does **not** leak.

Torque Value: 8 N•m [72 in-lb]

Check for corrosion of the intake system piping under the clamps and hoses. Corrosion can allow corrosive products and dirt to enter the intake system. Disassemble and clean as required.

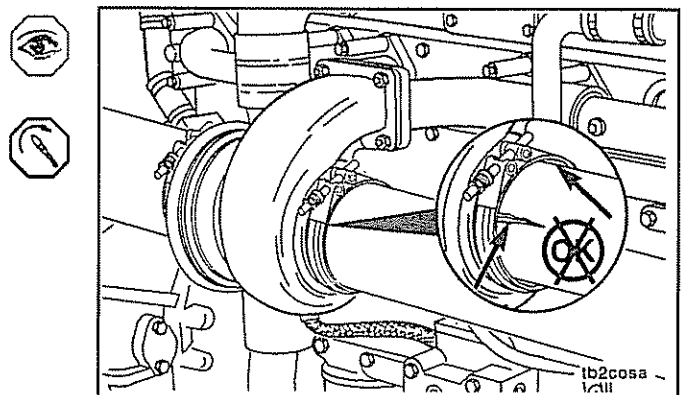

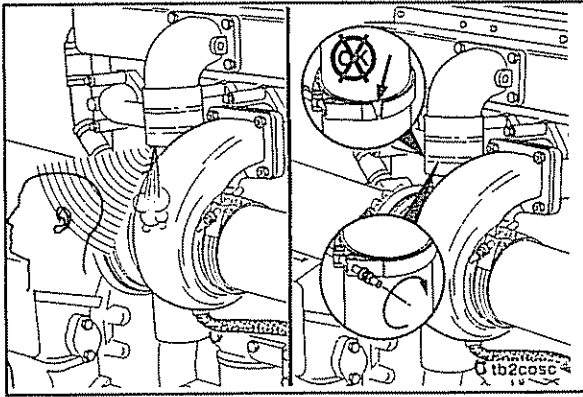

The noise can be caused by an air leak from the:

- turbocharger to discharge elbow connection

Inspect for damage. Tighten loose clamps.



Torque Value: 8 N•m [72 in-lb]

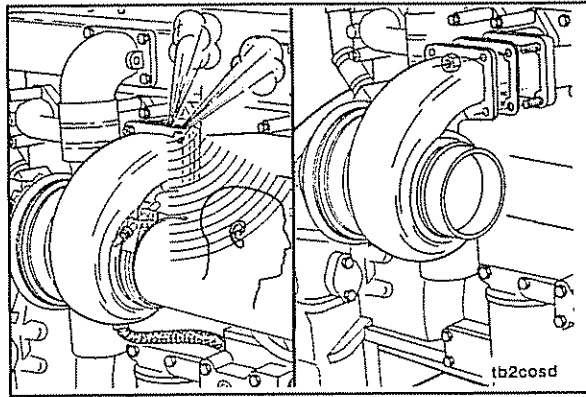

- turbocharger to exhaust manifold mounting gasket

Replace the gasket. Refer to Section A for turbocharger removal and installation.

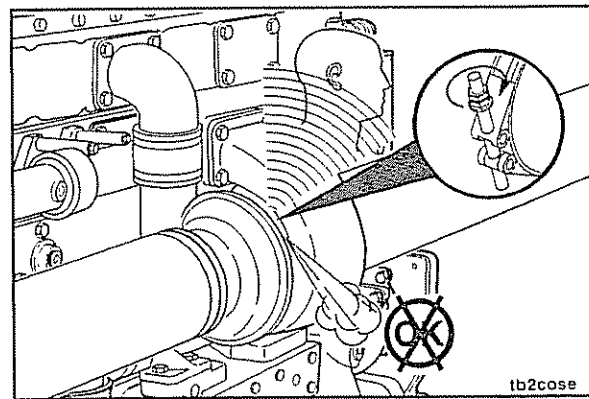

- turbine housing sealing surface exhaust leak

Tighten the turbine housing cap screws.



Torque Value:

Cap screws	14 N•m	[120 in-lb]
V-band	16 N•m	[140 in-lb]

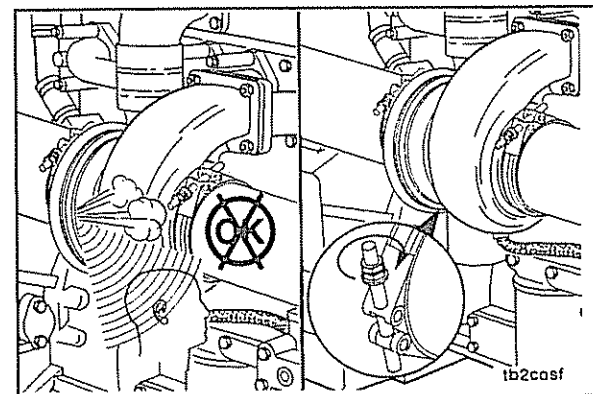

- compressor housing sealing surface air leak

Tighten the compressor housing v-band clamp nut.



Torque Value:

Cap screws	7 N•m	[60 in-lb]
V-band	9 N•m	[75 in-lb]

Air Tanks and Reservoirs

Drain

Open the draincock on the wet tank to drain any moisture accumulated in the air system. If oil is present, the air compressor system **must** be checked. Refer to the Troubleshooting and Repair Manual, M11 Series Engines (STC, CELECT™, CELECT™ Plus Models), Bulletin No. 3666139.

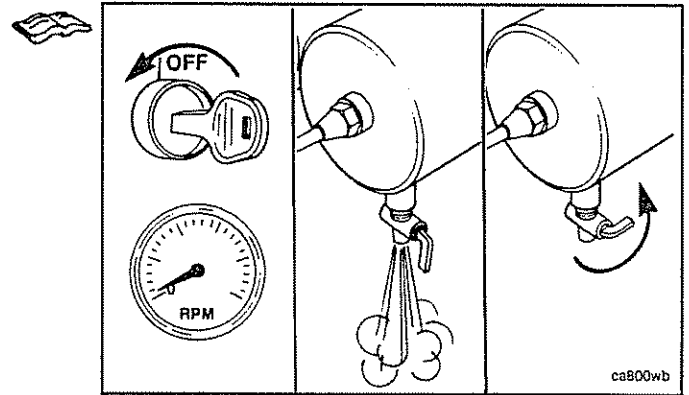

Maintenance Procedures at 250 Hours or 6 Months

Section Contents

	Page
Air Compressor Air Cleaner Element	5-9
Maintenance Service	5-9
Coolant Filter	5-7
Install	5-7
Remove	5-7
Fuel Filter (Spin-On Type)	5-1
Install	5-1
Fuel-Water Separator (Superfilter)	5-1
Remove	5-1
Lubricating Oil and Filters	5-2
Cummins/Fleetguard® Filter Specifications	5-4
Lubricating Oil Filters	5-4
Drain	5-2
Fill	5-5
Maintenance Procedures - General Information	5-1
Supplemental Coolant Additive (SCA)	5-8
Maintenance Check	5-8

THIS PAGE LEFT INTENTIONALLY BLANK.

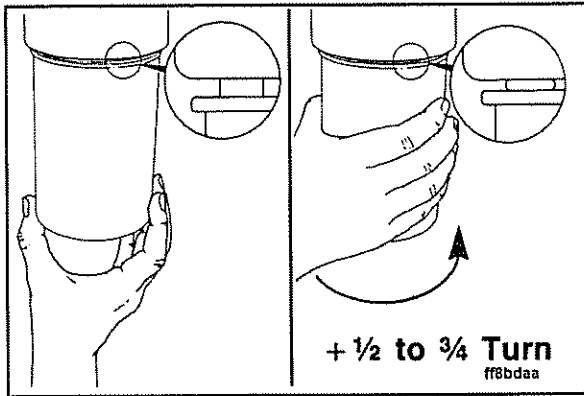

CAUTION

Mechanical overtightening of the filter can distort the threads or damage the filter element seal.

Install the filter on the filter head. Turn the filter until the gasket contacts the filter head surface.

Tighten the filter an additional one-half to three-fourths of a turn after the gasket contacts the filter head surface, or as specified by the filter manufacturer.

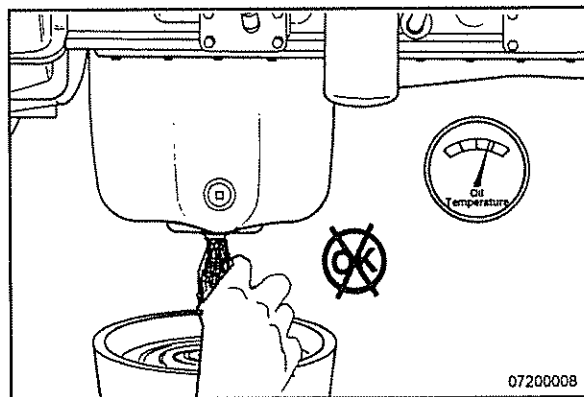

Lubricating Oil and Filters

Drain

Change the lubricating oil and filter(s) at the specified oil change interval. Refer to Lubricating Oil Recommendations/Specifications (Section V) to find the correct change interval for your application.

WARNING

Some state and federal agencies in the United States of America have determined that used engine oil can be carcinogenic and can cause reproductive toxicity. Avoid inhalation of vapors, ingestion, and prolonged contact with used engine oil.

WARNING

Avoid direct contact of hot oil with your skin. Hot oil can cause personal injury.

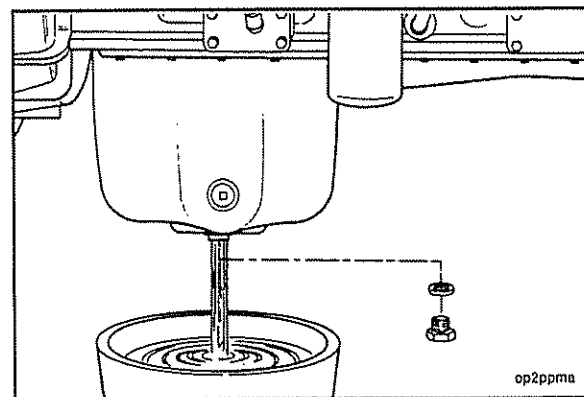

Change the lubricating oil and filter at the specified oil change interval. Refer to Lubricating Oil Recommendations/Specifications in Section V to find the correct change interval for you application.

Operate the engine until the water temperature reaches 60°C [140°F]. Shut off the engine. Remove the oil drain plug from the bottom of the lubricating oil pan. Do not remove the plugs on either side of the oil pan to drain the oil. They will not allow the oil to drain completely.

NOTE: Fittings used in the bottom drain opening of the oil pan other than Cummins specified parts **must not** exceed the following size and weight limits:

Oil Drain Fitting Specs

Length	63.50 mm	[2.500 in]
Diameter	41.28 mm	[1.625 in]
Weight	0.363 mm	[0.80 lbf]

Do not use fittings other than the Cummins supplied fitting in the side drain location.

**M11
Maintenance Procedures at 250 Hours or 6 Months**

On standby generator applications, Cummins Engine Company, Inc. recommends oil sampling and analysis at the time of oil change to monitor oil contaminant levels.

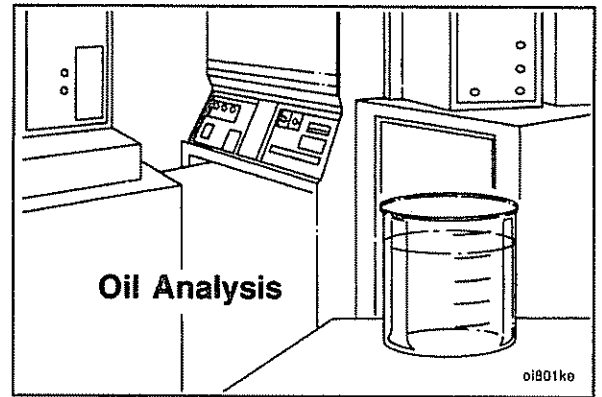

Clean the area around the lubricating oil filter head.
Use oil filter wrench, Part No. 3375049, to remove the filter
Clean the gasket surface of the filter head. The o-ring can stick on the filter head. Make sure it is removed.

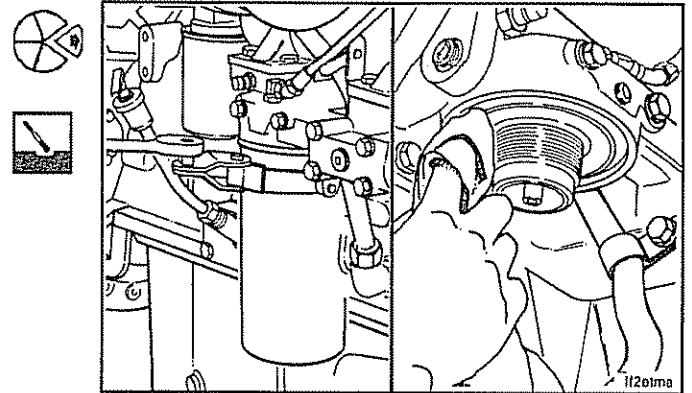

Cummins/Fleetguard® Filter Specifications

Lubricating Oil Filters

Cummins Engine Company, Inc. requires a lubricating oil filter(s) be used that meets the specifications given in the table below.

Lubricating Oil Filter Specifications			
Per Cummins Source Approval Method (SAM)	Combo (LF3000) 10,634	Full Flow (LF670) 10,509	Bypass (LF777) 10,547
Flow vs. Restriction Pressure differential at 40 GPM maximum	21 kPa [3 psi]	21 kPa [3 psi]	N/A
Element Collapse Pressure differential	1034 kPa [150 psi]	1034 kPa [150 psi]	1034 kPa [150 psi]
Partical Retention Absolute retention, percent of 40 micrometre and above, minimum	N/A	100%	N/A
Percent retention of 20 to 30 micrometre	N/A	95 %	N/A
Hydrostatic Pressure Pressure, minimum	1724 kPa [250 psi]	1724 kPa [250 psi]	1724 kPa [250 psi]

Fill

Clean the oil filter head surface

Use clean 15W-40 oil to coat the gasket surface of the filter.

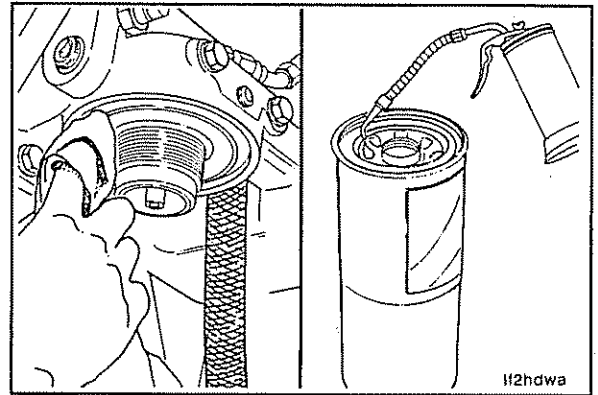

Use the correct oil filter for your engine. Cummins Engine Company, Inc. requires a lubricating oil filter(s) be used that meets the specifications given in the table following this text block per Cummins SAM 10,509/10,547/10,634.

Combination Lube Filter

Cummins Part No. 3318853

Fleetguard® Part No. LF-3000

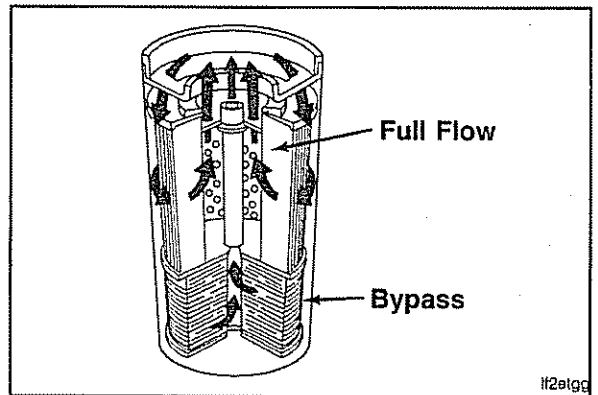

CAUTION

The lack of lubrication during the delay until the filter is pumped full of oil at startup is harmful to the engine.

Fill the filter with clean 15W-40 oil.

CAUTION

Mechanical overtightening of the filter can distort the threads or damage the filter element seal.

Install the filter on the filter head. Tighten the filter until the gasket contacts the filter head surface.

Use oil filter wrench, Part No. 3375049, to tighten the filter to the specifications supplied with the filter.

Clean and check the oil drain plug threads and the seal surface.

Install the oil drain plug in the lubricating oil pan.

Torque Value: 88 N•m [65 ft-lb]

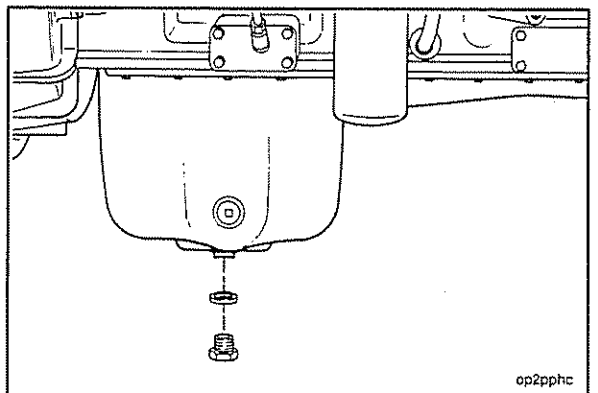
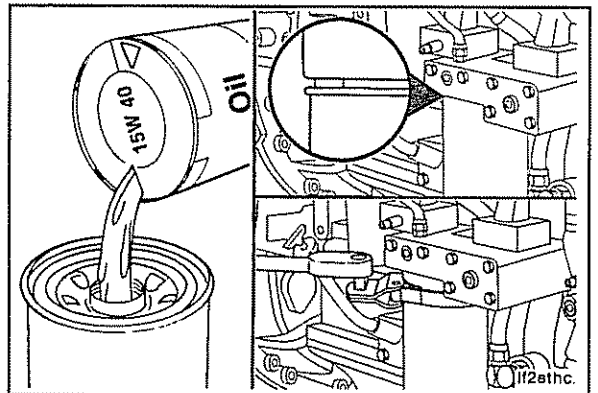

Maintenance Procedures at 250 Hours or 6 Months

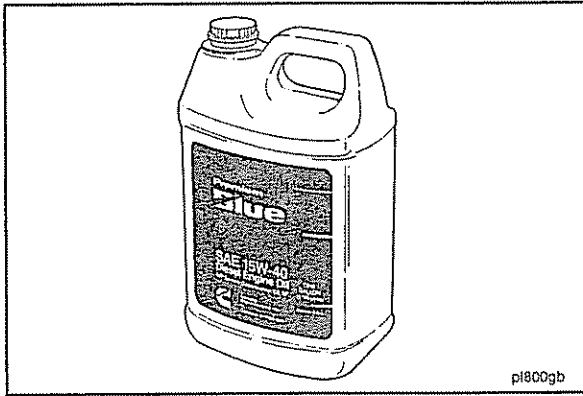

Use a high quality API CG-4 or CF-4 15W-40 multi-viscosity oil such as Cummins Premium Blue, or its equivalent, in Cummins engines. Choose the correct oil for your operating climate as outlined in Section V.

NOTE: In areas where CG-4 or CF-4 engine oils are **not** yet available, contact your Cummins Distributor for other oil recommendations.

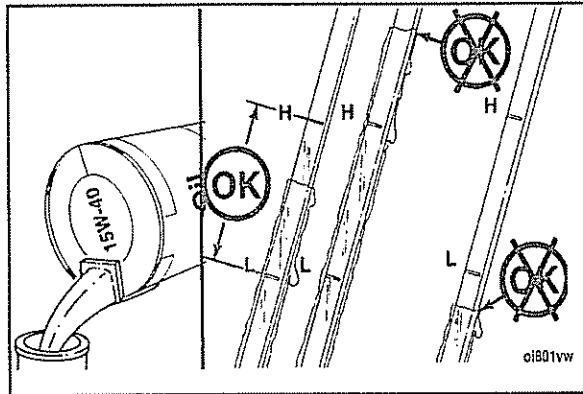

Fill the engine with clean oil to the correct level. Total system capacity including filter is approximately 39 liters [10.3 U.S. gal].

NOTE: The oil pan capacity is 34 liters [9 U.S. gal]. The filter capacity is 2.6 liters [0.7 U.S. gal].

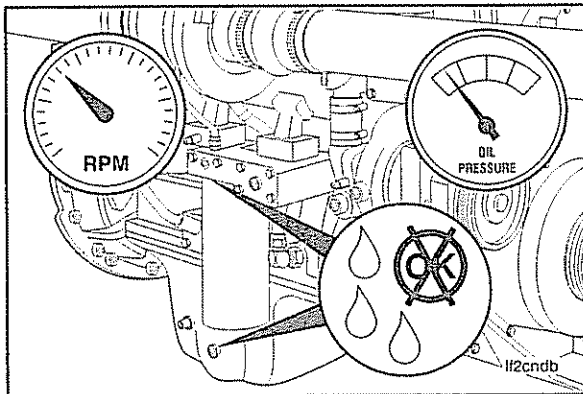

Operate the engine at idle speed to inspect for leaks at the filter(s) and the drain plug.

NOTE: Engine oil pressure **must** be indicated on the gauge within 15 seconds after starting. If oil pressure is **not** registered within 15 seconds, shut off the engine immediately to avoid engine damage. Confirm the correct oil level in the oil pan.

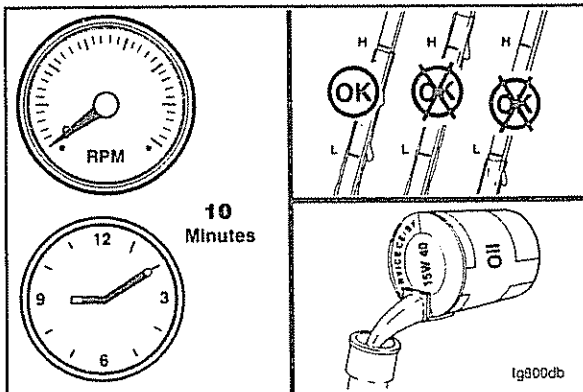

Shut off the engine. Wait approximately 10 minutes for the oil to drain back from the upper parts of the engine to the oil pan.

Check the oil level again. Add oil as necessary to bring the level up to the "H" (high) mark on the dipstick.

Coolant Filter

Remove

Change the coolant filter at every oil and filter change interval unless the supplemental coolant additive (SCA) level is over three units. Refer to Coolant Additive Concentration — Check in this section.

NOTE: The SCA level **must** be tested every six months.

The correct coolant filter to be used is determined by the total cooling system capacity and other operational factors. Refer to Coolant Recommendations and Specifications (Section V) for the correct filter selection.

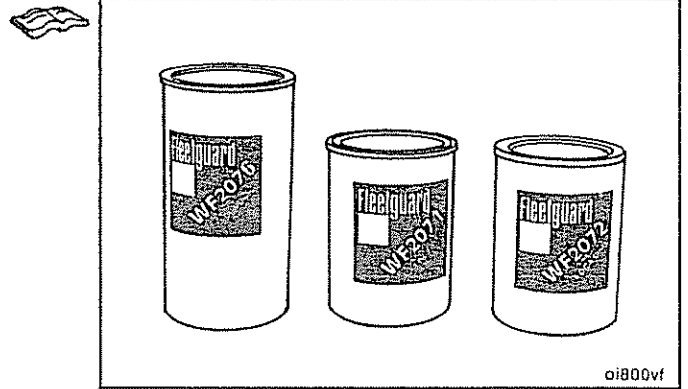

▲ WARNING ▲

Do not remove the radiator cap from a hot engine. Hot steam will cause serious personal injury. Remove the coolant system pressure cap and close the shutoff valve(s), if equipped, before removing the coolant filter. Failure to do so can result in personal injury from heated coolant spray.

Turn the valve on the filter head to the "OFF" position.

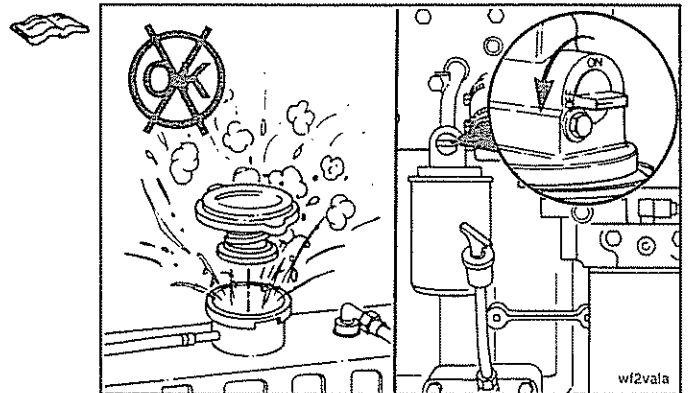

▲ WARNING ▲

There could be slight coolant leakage with the valve in the "OFF" position. Use caution when cleaning the gasket surface to avoid contact with hot coolant. Failure to do so can result in personal injury from heated coolant.

Remove and discard the coolant filter. Clean the gasket surface.

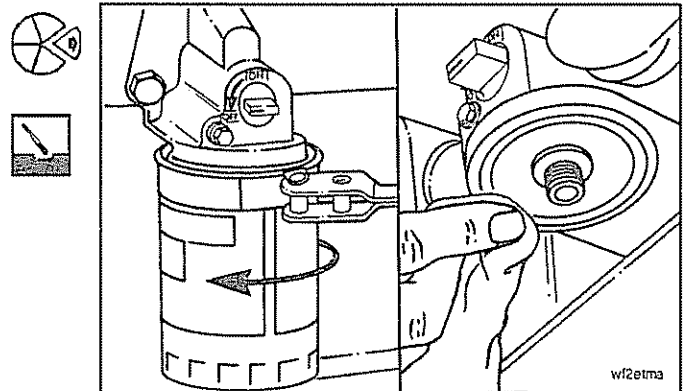

Install

Apply a film of lubricating oil to the gasket sealing surface before installing the new coolant filter.

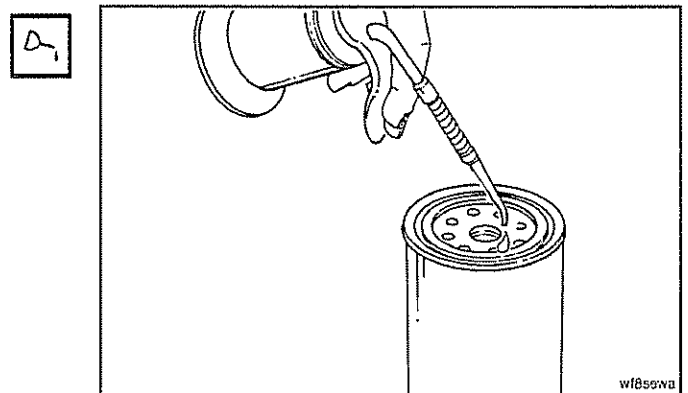

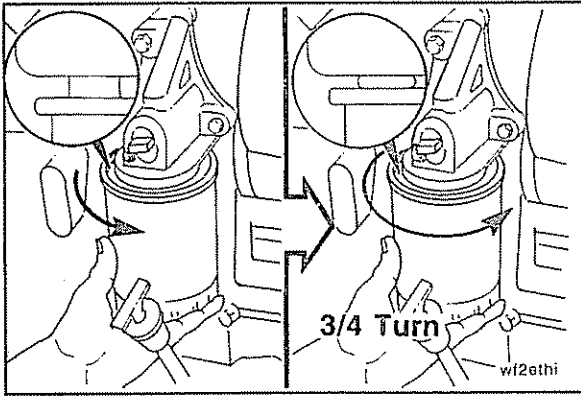

CAUTION

Mechanical over-tightening can distort the filter threads or damage the filter head.

Install the new filter on the filter head. Tighten the filter until the gasket contacts the filter head surface.

Tighten the filter an additional one-half to three-fourths of a turn, or as specified by the filter manufacturer.

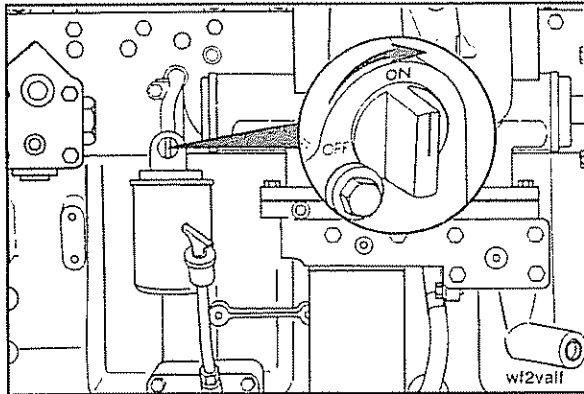

CAUTION

The valve must be in the "ON" position to prevent engine damage.

Turn the valve on the filter head to the "ON" position and install the coolant system pressure cap.

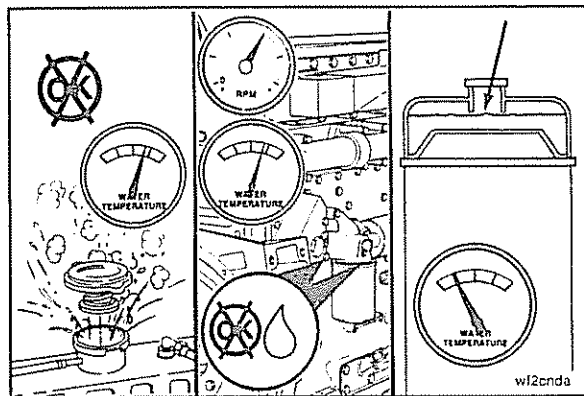

Operate the engine and check for leaks.

After the air has been purged from the system, check the coolant level again.

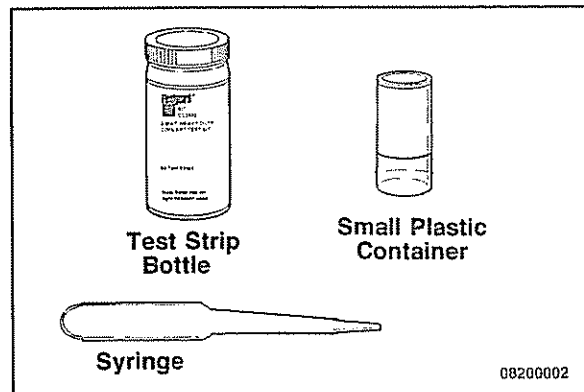

Supplemental Coolant Additive (SCA) Maintenance Check

Check the SCA concentration level:

- At least twice a year
- At every subsequent oil drain interval if the concentration is above 3 units
- Whenever coolant is added to the cooling system between filter changes

Use Fleetguard® coolant test kit, Part No. CC2602, to check the concentration level. Instructions are included with the test kit. Refer to Coolant Recommendations and Specifications in Section V for the correct SCA level.

Air Compressor Air Cleaner Element Maintenance Service

Every 250 hours remove the wing nut which secures the cover to the housing. Remove the cover and the element. Clean the cover and the housing with a clean cloth. Inspect the rubber gasket on the center bolt. Replace if damaged. Install a new element, Fleetguard® Part No. AF-251 or Cummins Part No. 256837, in the front cover and assemble over the center bolt. Use your fingers to install and tighten the wing nut.

NOTE: If other compressors are used, follow the manufacturer's service requirements.

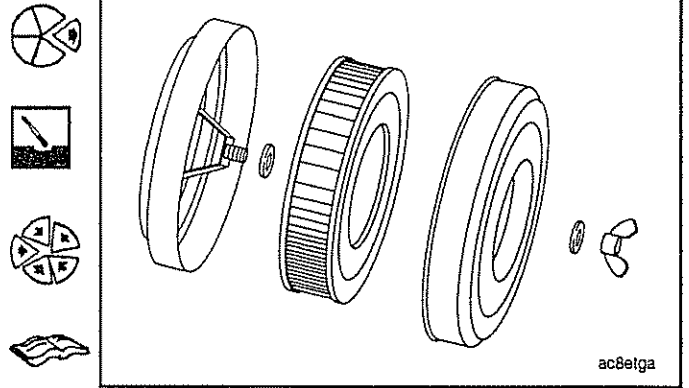

Maintenance Procedures at 1,500 Hours

Section Contents

	Page
Engine Mounting Bolts	6-9
Maintenance Check	6-9
Engine Steam Cleaning	6-9
Clean	6-9
Maintenance Procedures - General Information	6-1
Overhead Set	6-1
Adjust	6-1
Radiator Shutter Assembly	6-8
Maintenance Check	6-8
Turbocharger	6-8
Maintenance Check	6-8
Water Pump	6-7
Maintenance Check	6-7



THIS PAGE LEFT INTENTIONALLY BLANK.

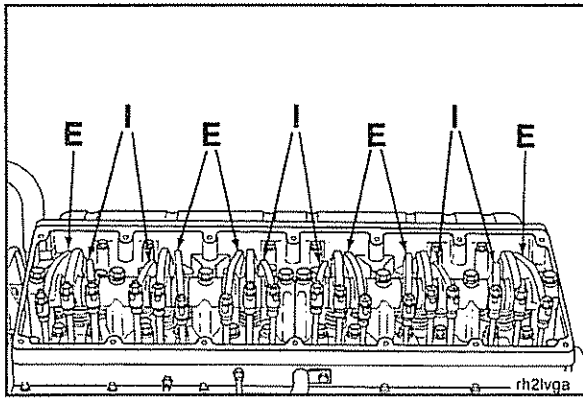

Each cylinder has three rocker levers:

- The long rocker lever (E) is the exhaust lever.
- The center rocker lever is the injector lever.
- The short rocker lever (I) is the intake lever.

Refer to the accompanying chart for valve rocker lever locations.

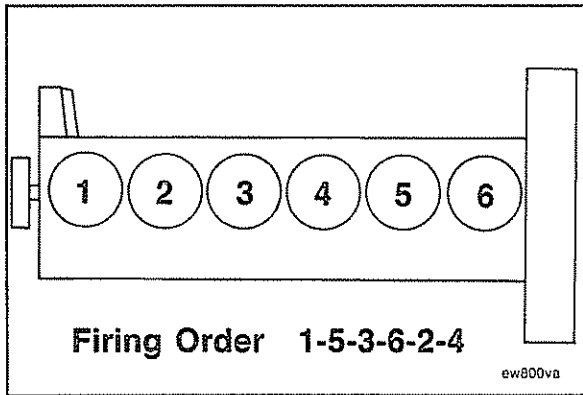

The crankshaft rotation is **clockwise** when viewed from the front of the engine.

The cylinders are numbered from the front gear cover end of the engine.

The engine firing order is 1-5-3-6-2-4.

STC Injector and Valve Adjustment Sequence			
Bar Engine in Direction of Rotation	Pulley Position	Set Cylinder Injector	Valve
Start	A	3	5
Advance to	B	6	3
Advance to	C	2	6
Advance to	A	4	2
Advance to	B	1	4
Advance to	C	5	1

Firing Order: 1-5-3-6-2-4

oi200vi

The valves and injectors on the same cylinders are **not** adjusted at the same index mark on the accessory drive pulley on STC engines.

One pair of valves and one injector are adjusted at each pulley index mark **before** rotating the accessory drive to the next index mark.

Two crankshaft revolutions are required to adjust all the valves and injectors.

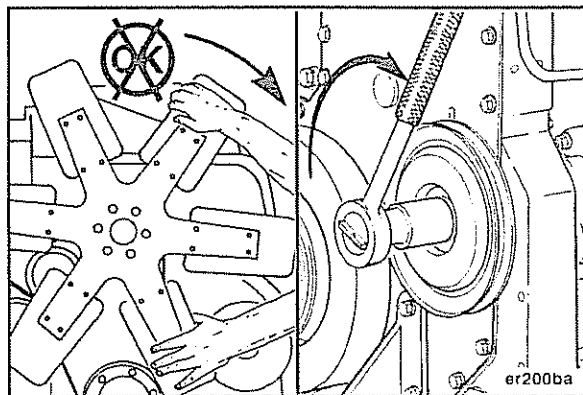

▲ WARNING ▲

Do not pull or pry on the fan to manually rotate the crankshaft. To do so can damage the fan blades. Damaged fan blades can cause premature fan failures which can result in serious personal injury or property damage.

The valve set marks are located on the accessory drive pulley. The marks align with a pointer on the gear cover.

Use the accessory drive shaft to rotate the crankshaft.

The adjustment can begin on any valve set mark. In the following example the adjustment will begin on the "A" valve set mark with cylinder number five valves closed and cylinder number three injector ready for adjustment.

Rotate the accessory drive shaft **clockwise** until the "A" valve set mark on the accessory drive pulley is aligned with the pointer on the gear cover.

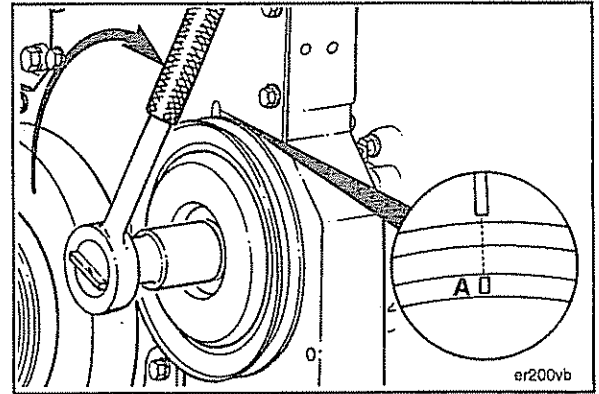

When the "A" mark is aligned with the pointer, the intake and exhaust valves for cylinder number five **must** be closed. If these conditions are **not** correct, cylinder number four injector and cylinder number two valves **must** be ready to set.

Both valves are closed when both rocker levers are loose and can be moved from side to side.

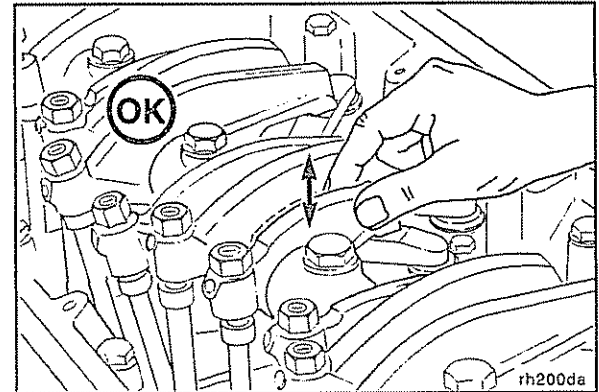

Loosen the injector adjusting screw locknut on cylinder number three. Tighten the adjusting screw until all the clearance is removed from the injector train.

Tighten the adjusting screw one additional turn to correctly seat the link.

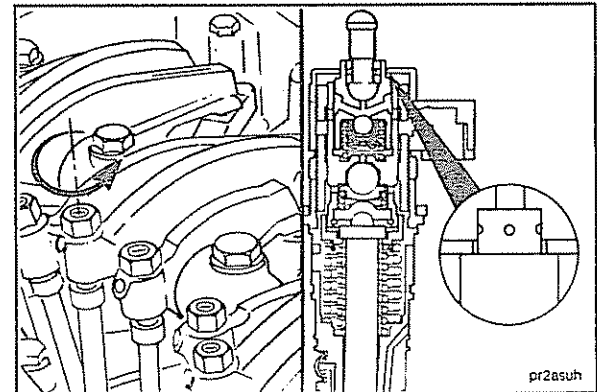

Loosen the injector adjusting screw until the STC tappet touches the top-cap of the injector.

Be sure to loosen the adjusting screw enough, so there is no preload on the injector. This will be accomplished when the rocker lever is loose enough to move.

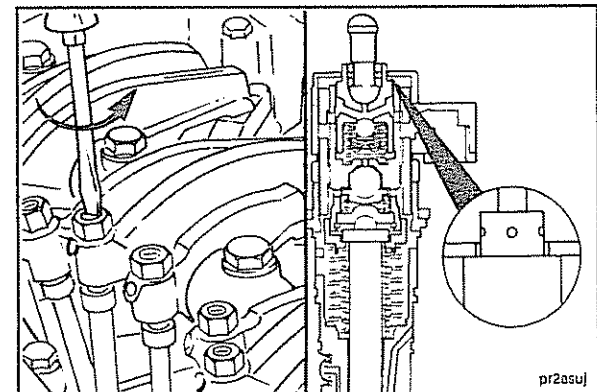

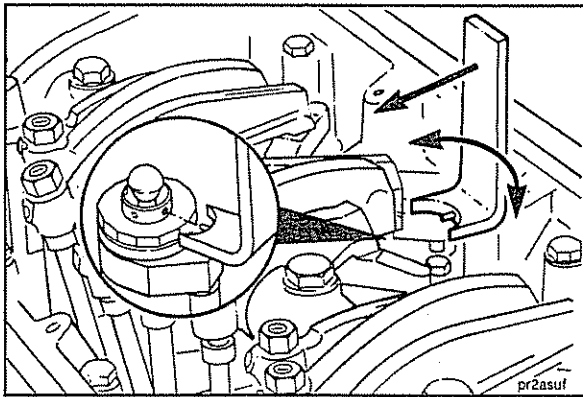

Place the STC tappet adjusting tool, Part No. 3823348, on the upper surface of the STC injector top-cap. Rotate the tool around the tappet until the tool's locating pin is inserted into one of the four holes in the top of the tappet.

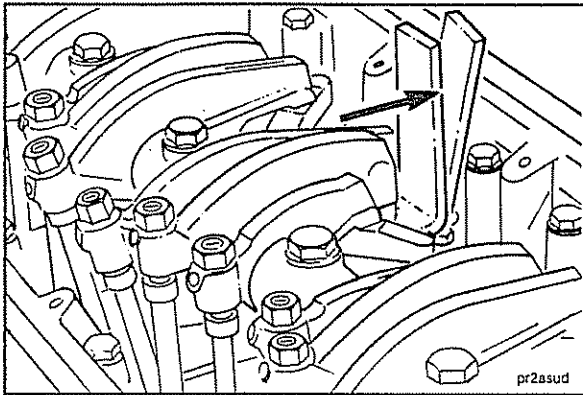

Apply thumb pressure to the tool handle to hold the tappet in the maximum upward position.

NOTE: Apply only enough force to the tool to hold the tappet in the maximum upward position. Excess force will cause the tool to break.

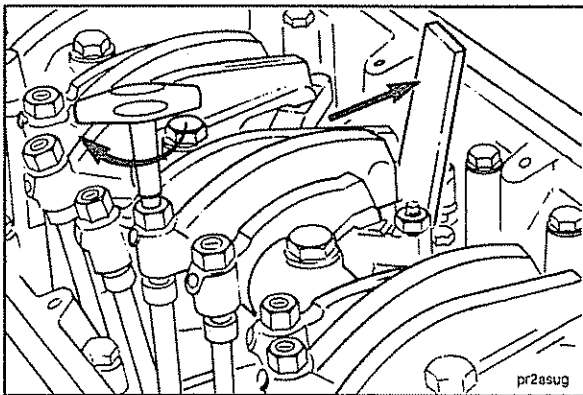

CAUTION

An overtightened setting on the injector adjusting screw will produce increased stress on the injector train and the camshaft injector lobe which can result in engine damage.

Use torque wrench, Part No. 3376592, to tighten the adjusting screw while holding the tappet in the maximum upward position.

Torque Value: 0.6 to 0.7 N•m [5 to 6 in-lb]

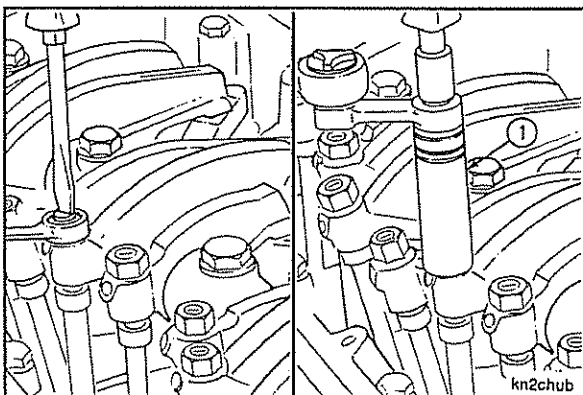

Hold the adjusting screw in this position. The adjusting screw **must not** turn when the locknut is tightened.

Torque Value:

- **Without Torque Wrench Adapter:**
61 N•m [45 ft-lb]
- **With Torque Wrench Adapter (1):**
47 N•m [35 ft-lb]

The tappet tool **must** be removed before rotating the crankshaft to prevent damage to the tappet.

Remove the tappet adjusting tool.

Check to make sure the injector push rod can be rotated by hand. If it can't, the setting is too tight.

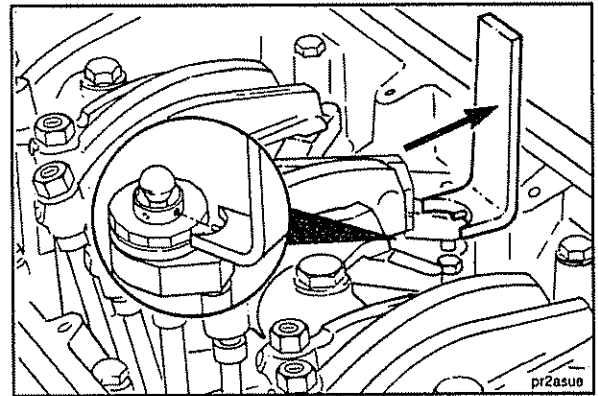

Adjust the valves on the appropriate cylinder according to the sequence chart before rotating the accessory drive to the next valve set mark.



STC Injector and Valve Adjustment Sequence			
Bar Engine in Direction of Rotation	Pulley Position	Set Cylinder Injector	Set Cylinder Valve
Start	A	3	5
Advance to	B	6	3
Advance to	C	2	6
Advance to	A	4	2
Advance to	B	1	4
Advance to	C	5	1

Firing Order: 1-5-3-6-2-4 ol200vi

Select a feeler gauge for the correct valve lash specification.

	Valve Lash Specification	
	mm	in
Intake	0.36	0.014
Exhaust	0.69	0.027

Insert the feeler gauge between the top of the crosshead and the rocker lever pad.

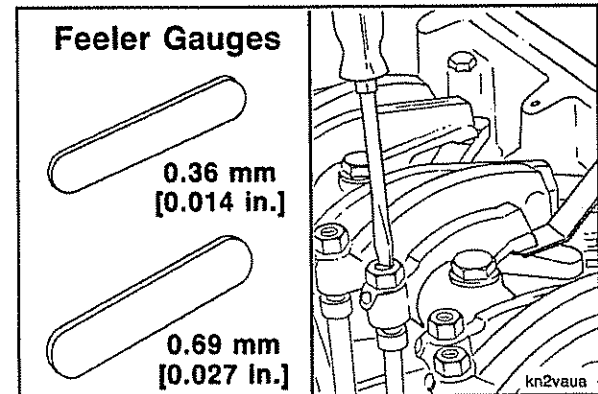

Two different methods for establishing valve lash clearance are described below. Either method can be used; however, the torque wrench method has proven to be the most consistent. It eliminates the need to feel the drag on the feeler gauge.



- **Torque Wrench Method:** Use the inch pound torque wrench. Part No. 3376592, (normally used to set preload on top stop injectors), and tighten the adjusting screw.

Torque Value: 0.7 N•m [6 in-lb]

- **Touch Method:** Tighten the adjusting screw until a light drag is felt on the feeler gauge.

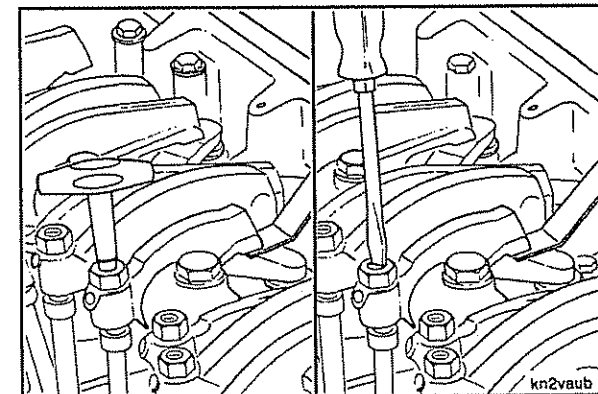

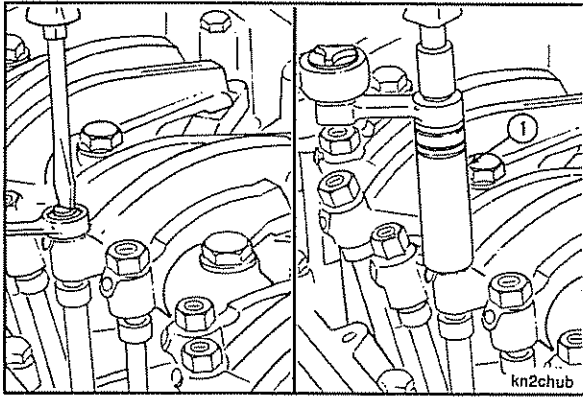

Hold the adjusting screw in this position. The adjusting screw **must not** turn when the locknut is tightened. Tighten the locknut.

Torque Value:

- **Without Torque Wrench Adapter:**
61 N•m [45 ft-lb]
- **With Torque Wrench Adapter (1):**
47 N•m [35 ft-lb]

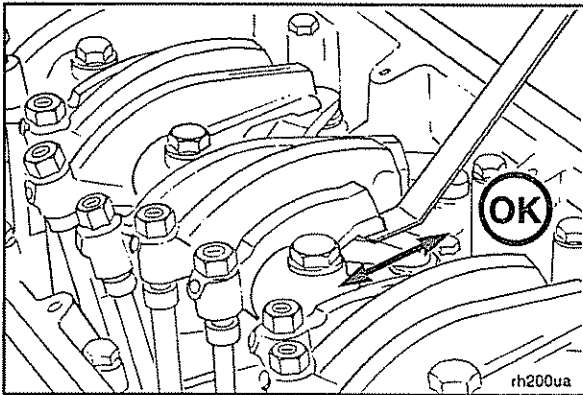

After tightening the locknut to the correct torque value, check to make sure the feeler gauge will slide backward and forward between the crosshead and the rocker lever with only a slight drag.

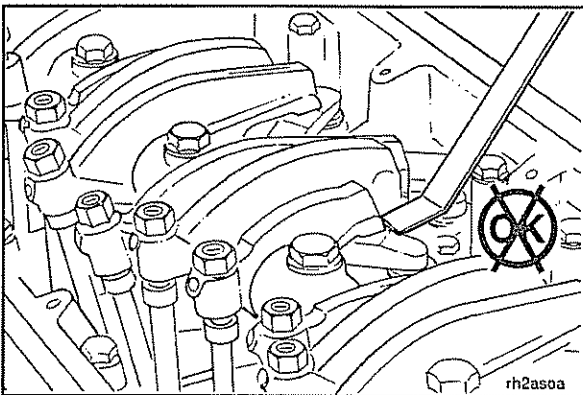

If using the touch method, attempt to insert a feeler gauge that is 0.03 mm [0.001 inch] thicker between the crosshead and the rocker lever pad. The valve lash is **not** correct when a thicker feeler gauge will fit.

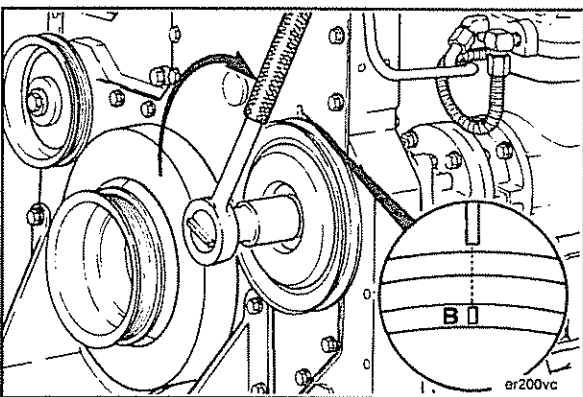

After adjusting the valves, rotate the accessory drive and align the next valve set mark on the accessory drive pulley with the pointer on the gear cover.

**M11
Maintenance Procedures at 1,500 Hours**

Adjust the appropriate injector and valves following the Injector and Valve Adjustment Sequence Chart.



Repeat the process to adjust all injectors and valves.

After adjusting all the injectors and valves, check the torque on the adjusting screw locknuts to make sure none were overlooked.

STC Injector and Valve Adjustment Sequence			
Bar Engine in Direction of Rotation	Pulley Position	Set Cylinder Injector Valve	
Start	A	3	5
Advance to	B	6	3
Advance to	C	2	6
Advance to	A	4	2
Advance to	B	1	4
Advance to	C	5	1

Firing Order: 1-5-3-6-2-4 o1200vl

If the valve cover gasket was **not** damaged, it can be used again. If the gasket was damaged, it **must** be discarded and a new one used.



Install the gasket on the cover.

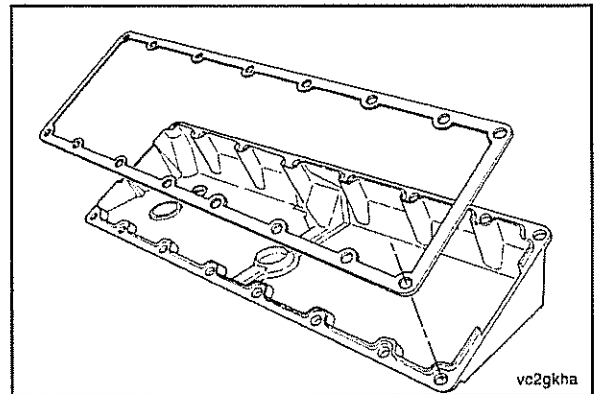

Install the cover on the rocker lever housing.
Install the 16 isolators, spacers and capscrews in the cover.
Tighten the capscrews in the sequence shown.



Torque Value: 15 N•m [130 in-lb]

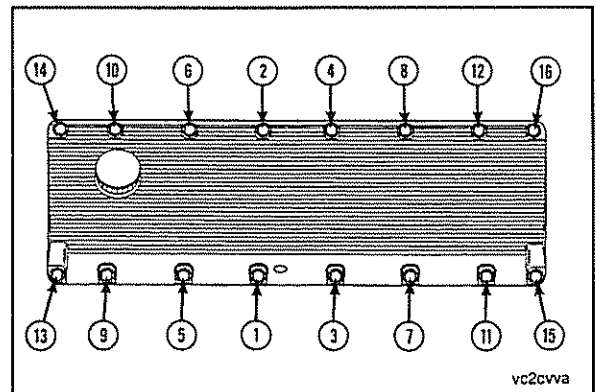

**Water Pump
Maintenance Check**

Every 1500 hours visually check the water pump body for indications of water leakage at the weep hole.



A streak or chemical buildup at the weep hold is **not** justification for water pump replacement. If a steady flow of coolant or oil is observed, replace the water pump with a new or rebuilt unit.



Refer to Section A for the replacement procedure.

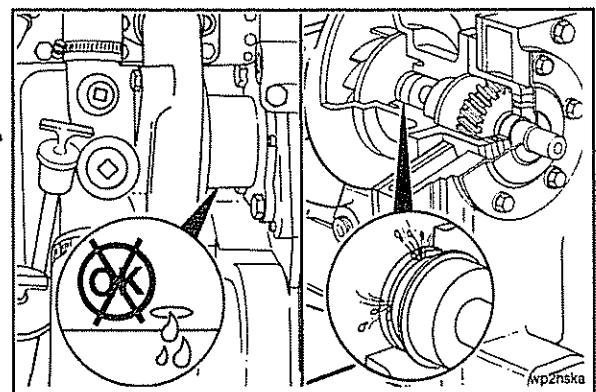

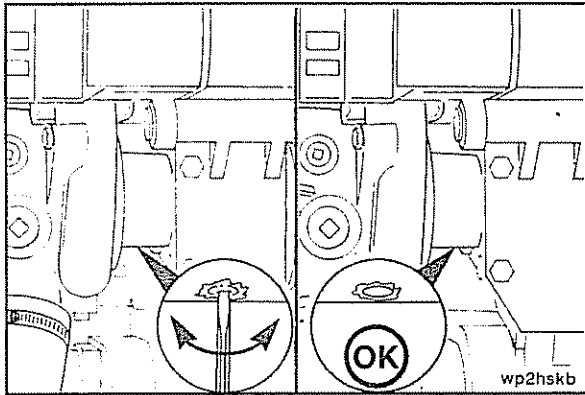

Make sure the weep hole is open. A small screwdriver or a similar tool can be used to remove any debris.

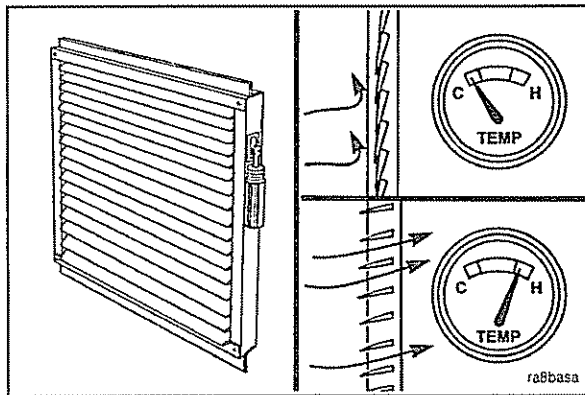

Radiator Shutter Assembly Maintenance Check



Check the shutters and the thermostatic fan every 1500 hours.

Check the shutters in the closed position to be sure they are completely closed.

NOTE: If the shutters are **not** closed, refer to the manufacturer's instructions.

Be sure the shutters open completely at the desired temperature setting.

NOTE: If the shutters are **not** open, refer to the manufacturer's instructions.

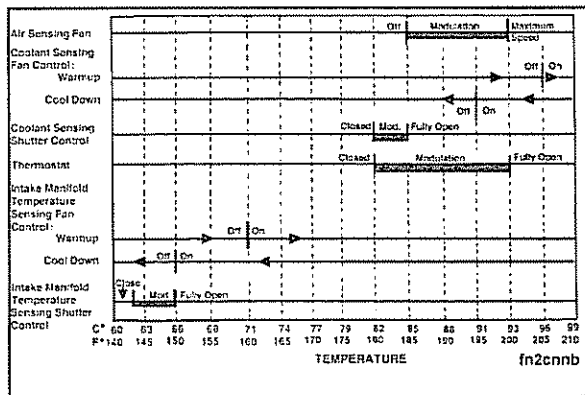

Shutters and thermostatic fans **must** be set to operate in the same temperature range as the thermostat with which they are used. Refer to the Thermal Control Settings chart in Section 1.

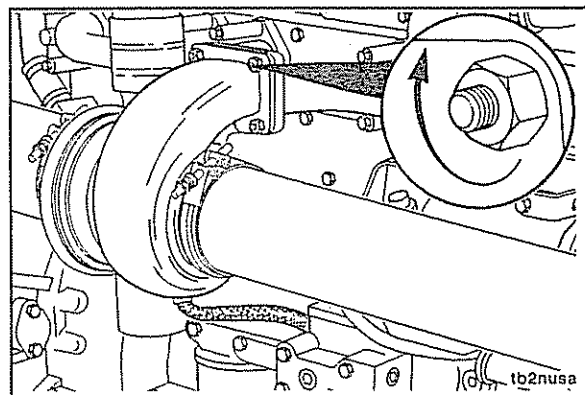

Turbocharger Maintenance Check



Every 1500 hours check the turbocharger mounting nuts.

Tighten the mounting nuts if necessary.

Torque Value: 61 N•m [45 ft-lb]

**M11
Maintenance Procedures at 1,500 Hours**

Check the turbine housing sealing surface for exhaust leaks.

If a leak is found, tighten the turbine housing capscrews or v-band clamp nut.

Torque Value:

Capscrews	14 N•m	[120 in-lb]
V-Band	16 N•m	[140 in-lb]

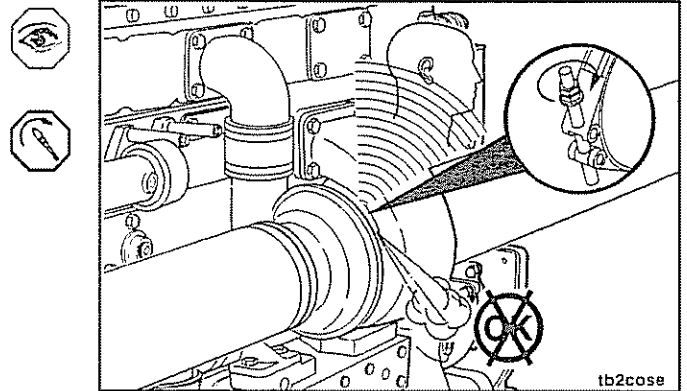

Check the compressor housing sealing surface for leaks.

If a leak is found, tighten the compressor housing capscrews or v-band clamp nut.

Torque Value:

Capscrews	9 N•m	[75 in-lb]
V-Band	9 N•m	[75 in-lb]

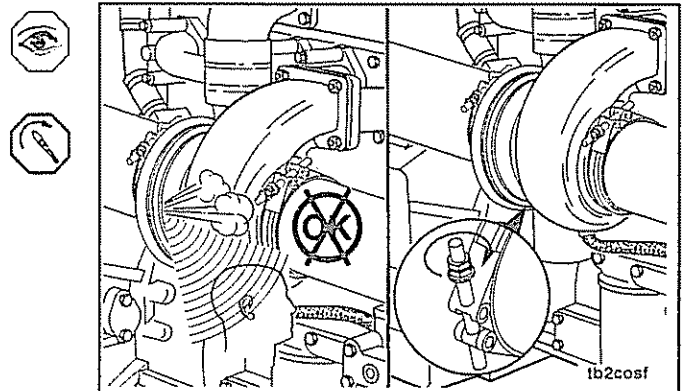

Engine Mounting Bolts

Maintenance Check

Every 1500 hours check the torque on the engine mounting nuts and bolts. Tighten any that are loose. Refer to the equipment manufacturer for torque specifications. Inspect the rubber for deterioration and age hardening. Replace any broken or lost bolts, capscrews, or damaged rubber.

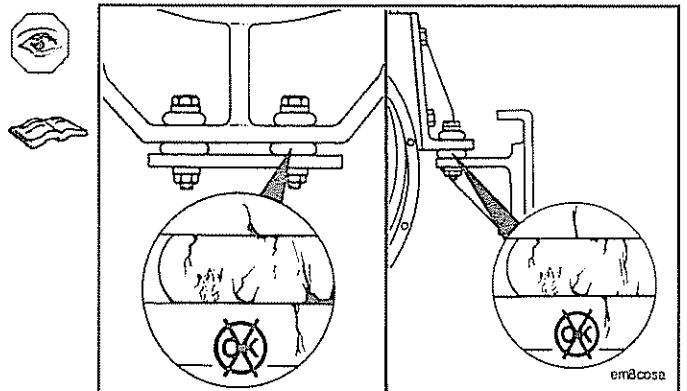

Engine Steam Cleaning

Clean



When using a steam cleaner, wear protective clothing and safety glasses or a face shield. Hot steam can cause serious personal injury.

Every 1500 hours the engine **must** be steam cleaned. Steam is the best method of cleaning a dirty engine or a piece of equipment. If steam is **not** available, use a solvent to wash the engine.

Protect all electrical components, openings, and wiring from the full force of the cleaner spray nozzle.

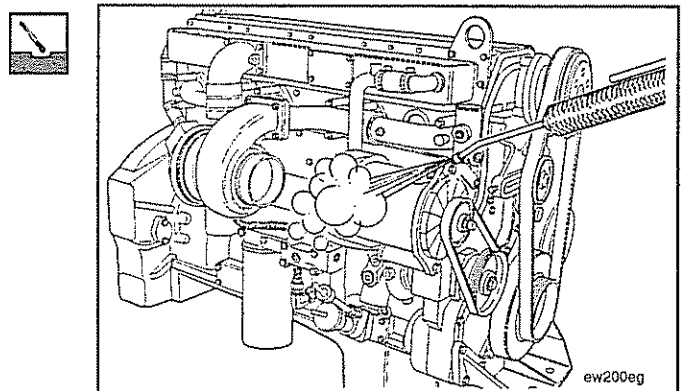

Maintenance Procedures at 6,000 Hours or 2 Years

Section Contents

	Page
Cooling System	7-1
Clean	7-1
Maintenance Check.....	7-3
Antifreeze	7-3
Maintenance Procedures - General Information	7-1



THIS PAGE LEFT INTENTIONALLY BLANK.

Maintenance Procedures - General Information

All checks or inspections listed under the daily maintenance interval **must** also be performed at this time in addition to those listed under this maintenance interval.

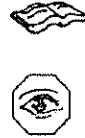

M11 Engine & Generator Subsystem					
Check or Measure	Interval	Every 250 Hours or 2 Months	Every 1000 Hours	Every 6000 Hours or 2 Years	Every 6000 Hours
Check	Check	Check	Adjust	Clean	Check and Clean
Operator's Manual Engine oil level Coolant level Air cleaner Fuel filter	All valves open Fuel filter Air filter Coolant level Fuel filter Air cleaner	Lubricating oil Lubricating oil Lubricating oil Lubricating oil Lubricating oil Lubricating oil	Throttle valve Injection valve Injection valve Injection valve Injection valve Injection valve	Cooling system Cooling system Cooling system Cooling system Cooling system Cooling system	Pressure Fuel pump Fuel pump Fuel pump Fuel pump Fuel pump
Visually inspect	Check and Clean	Replace	Check	Change	Inspect
Change oil Engine oil Coolant Fuel filter Air cleaner Fuel filter Air cleaner	All valves open Fuel filter Air filter Coolant level Fuel filter Air cleaner	Injection valve Injection valve Injection valve Injection valve Injection valve Injection valve	Throttle valve Injection valve Injection valve Injection valve Injection valve Injection valve	Throttle valve Injection valve Injection valve Injection valve Injection valve Injection valve	Pressure Fuel pump Fuel pump Fuel pump Fuel pump Fuel pump
Check	Clean	Clean	Inspect	Inspect	Inspect
Operator's Manual Coolant level Fuel filter Air cleaner Fuel filter Air cleaner	Injection valve Injection valve Injection valve Injection valve Injection valve Injection valve	Throttle valve Injection valve Injection valve Injection valve Injection valve Injection valve	Throttle valve Injection valve Injection valve Injection valve Injection valve Injection valve	Throttle valve Injection valve Injection valve Injection valve Injection valve Injection valve	Pressure Fuel pump Fuel pump Fuel pump Fuel pump Fuel pump

NOTE: Refer to the operator's manual for complete inspection and maintenance procedures.
1. Failure to perform maintenance or replacement procedures for all items covered may result in engine damage, reduced performance, or safety hazards. Always use proper safety procedures when working on the engine. Never attempt to start the engine if it is not in proper condition.
2. For daily generator operation, the maximum of 6000 hours or 2 years, whichever comes first, must be used.
3. These maintenance intervals must be performed at least at the intervals shown. At each interval and subsequent interval, perform all preventive maintenance procedures which are due for scheduled maintenance.
4. Do not change the coolant filter if the A/C compressor will be used.

Cooling System

Clean

Every 6,000 hours or 2 years of operation, whichever comes first, change the coolant and antifreeze.



Do not use caustic cleaners in the cooling system. Aluminum components will be damaged.

The cooling system **must** be clean to work correctly and to eliminate buildup of harmful chemicals.

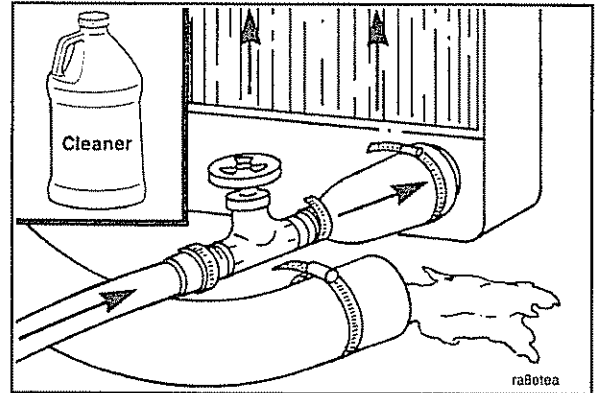

Wait until the temperature is below 50°C [120°F] before removing the coolant system pressure cap. Failure to do so can cause personal injury from heated coolant spray.

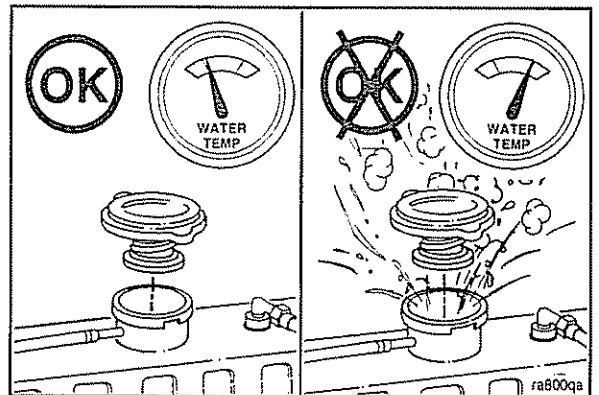

RESTORE is a heavy duty cooling system cleaner which removes corrosion products, silicate gel and other deposits. The performance of RESTORE is dependent on time, temperature, and concentration levels. An extremely scaled or flow restricted system, for example, can require higher concentrations of cleaners, higher temperatures, or longer cleaning times or the use of RESTORE PLUS. Up to twice the recommended concentration levels of RESTORE can be used safely. RESTORE PLUS **must** be used only at its recommended concentration level. Extremely scaled or fouled systems can require more than one cleaning.

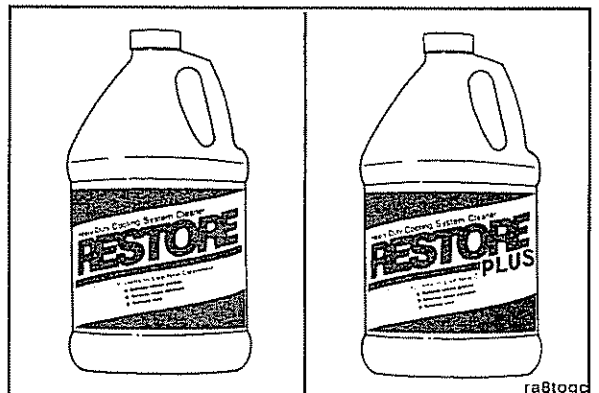

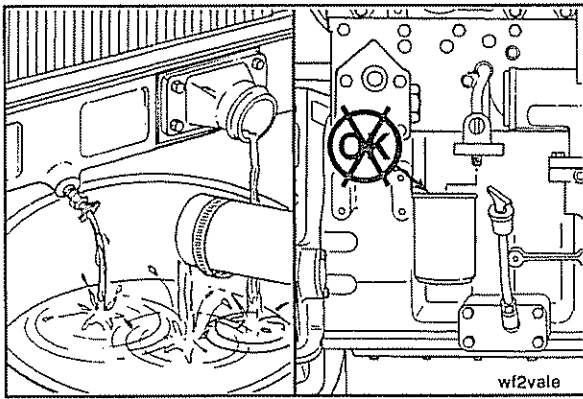

NOTE: Dispose of used antifreeze and coolant in accordance with federal, state, and local environmental regulations.

Drain the cooling system. Do **not** allow the cooling system to dry out.

Do **not** remove the coolant filter.

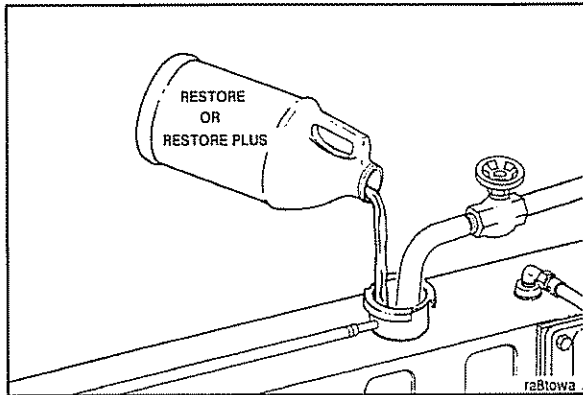

CAUTION

Fleetguard® RESTORE contains no antifreeze. Do not allow the cooling system to freeze during the cleaning operation.

Immediately add 3.8 liters [1 U.S. gal.] of Fleetguard® RESTORE, RESTORE PLUS, or equivalent, for each 38 to 57 liters [10 to 15 U.S. gal.] of cooling system capacity, and fill the system with plain water.

Turn the heater temperature switch to high to allow maximum coolant flow through the heater core. The blower does **not** have to be on.

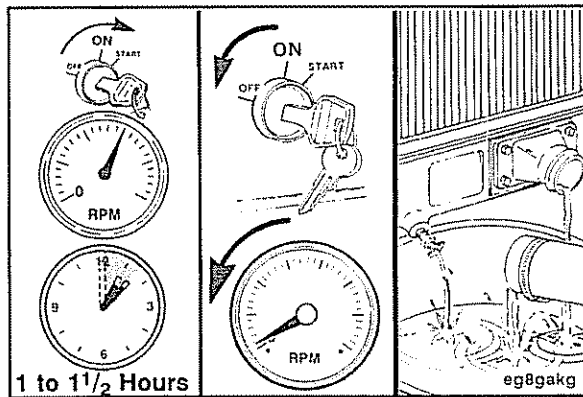

Operate the engine at normal operating temperatures, at least 85°C [185°F], for 1 to 1-1/2 hours.

Shut off the engine and drain the cooling system.

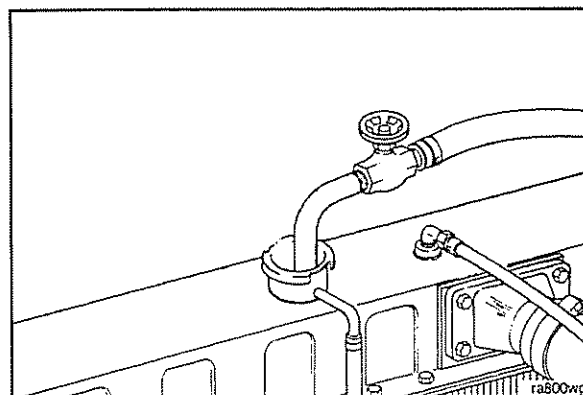

Fill the cooling system with clean water.

**M11
Maintenance Procedures at 6,000 Hours or 2 Years**

Operate the engine at high idle for five minutes with the coolant temperature above 85°C [185°F].

Shut off the engine and drain the cooling system.

If the water being drained is still dirty, the system **must** be flushed again until the water is clean.

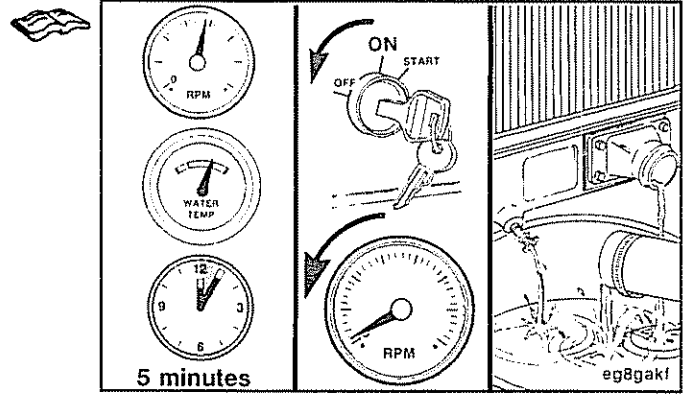

Fill the cooling system with **Fully Formulated Coolant** or a 50/50 mixture of **Fully Formulated Antifreeze** and good quality water. Use a service filter to bring the coolant to the correct SCA concentration level. Refer to the Coolant Specifications in Section V.

Install the pressure cap. Operate the engine until it reaches a temperature of 80°C [180°F], and check for coolant leaks.

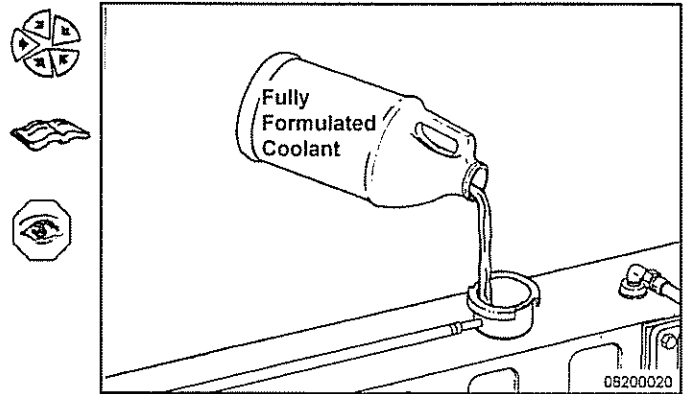

Maintenance Check

Antifreeze

Fully formulated antifreeze **must** be mixed with good quality water at a 50/50 ratio (40 to 60% working range). A 50/50 mixture of antifreeze and water gives a -36°C [-34°F] freeze point and a boiling point of 110C [228F], which is adequate for locations in North America. The actual lowest freeze point of ethylene glycol antifreeze is at 68%. Using higher concentrations of antifreeze will raise the freeze point of the solution and increase the possibility of a silicate gel problem.

Refer to Section V for water and antifreeze recommendations.

The Fleetguard® refractometer, Part No. C2800, provides a reliable, easy to read, and accurate measurement of freeze point protection and glycol (antifreeze) concentration.

The freeze point protection **must** be checked if coolant is added to the cooling system. Refer to the manufacturer's instructions for correct operation.

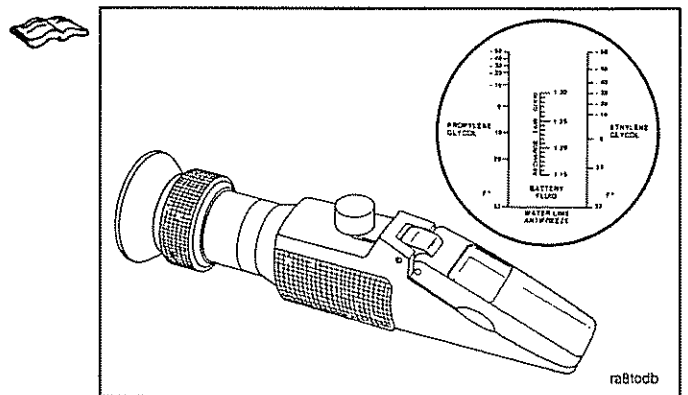
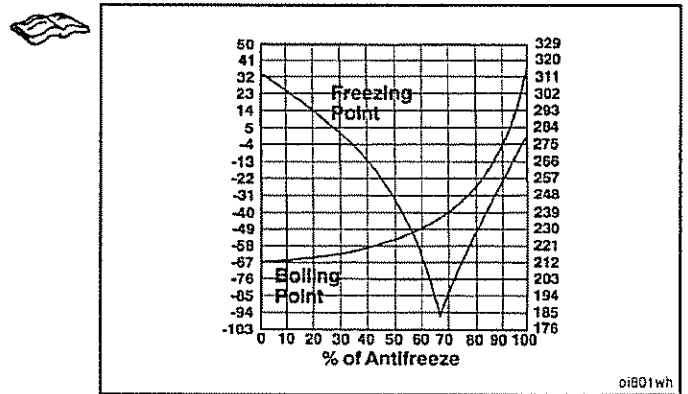

Maintenance Procedures at 6,000 Hours

Section Contents

	Page
Air Compressor Maintenance	8-11
Maintenance Check	8-11
Air Compressor Discharge — Inspect	8-11
Air Compressor Intake — Inspect	8-13
Fan Drive Idler Pulley Assembly	8-8
Maintenance Check	8-8
Fan Hub, Belt Driven	8-9
Maintenance Check	8-9
Fuel Pump	8-5
Install	8-7
STC	8-7
Remove	8-5
STC	8-5
Injector	8-1
Install	8-3
STC	8-3
Remove	8-1
STC	8-1
Maintenance Procedures - General Information	8-1
Turbocharger	8-9
Maintenance Check	8-9
Axial Clearance — Checking	8-10
Radial Bearing Clearance — Checking	8-9
Vibration Damper, Single	8-1
Maintenance Check	8-1

THIS PAGE LEFT INTENTIONALLY BLANK.

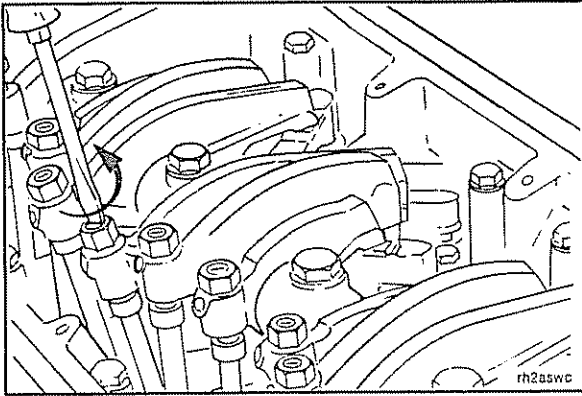

Loosen the locknut and turn out the adjusting screw on each injector and valve rocker lever.

Some push rods are under compression due to the valves being open. Rotate the crankshaft **clockwise** with the accessory drive pulley to relieve the spring tension.

NOTE: Mark the position of the push rods as they are removed. Due to wear patterns on the cam follower sockets and adjusting screws, the push rods **must** be installed in the same position as from which they are removed.

Hold the push rod with one hand to prevent it from falling into the engine. Loosen each adjusting screw and remove the push rod.

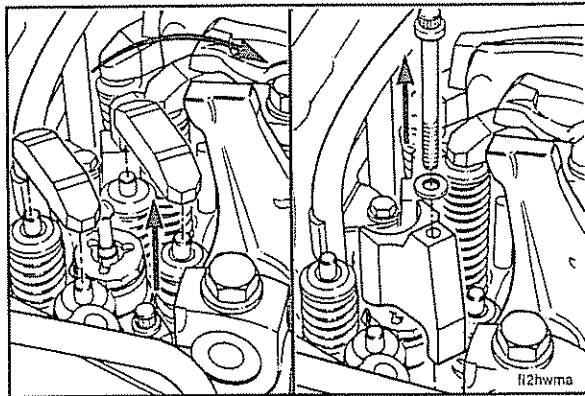

NOTE: Do **not** remove the links from STC injectors.

Rotate the injector and valve rocker levers up on each cylinder.

Remove the crossheads. Mark the position and orientation of the crossheads as they are removed. Due to wear patterns, they **must** be installed in the same locations from which they were removed.

Loosen the injector hold down capscrew and remove the hold down.

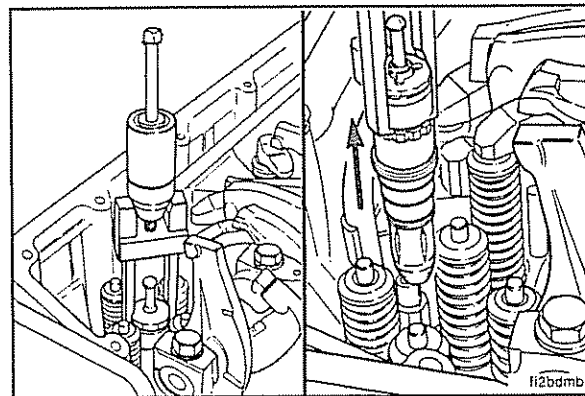

Use injector puller, Part No. 3823024, to remove the injectors.

Take the injectors to a Cummins Authorized Repair Location.

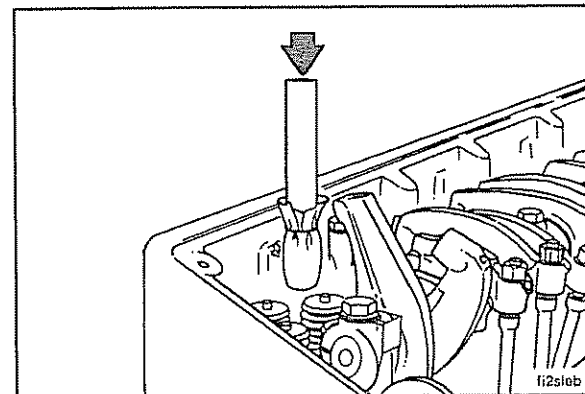

Do **not** use anything metal to scrape the injector copper sleeves. Damage to the injector sleeve can occur.

Use a clean wooden stick with a clean cloth wrapped around the end to remove all of the carbon from the injector copper sleeves in the cylinder head.

Install

STC

Install three new o-rings over the injector into the retaining grooves. Do **not** twist the o-rings.

Lubricate the o-rings with clean 15W-40 oil just before installation.

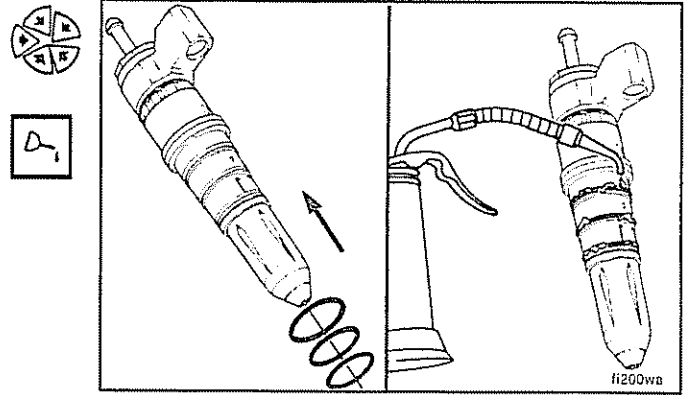

Check the bores in the cylinder head for burrs or sharp edges which can damage the o-rings. Repair damaged injector bores.

Install new o-rings on the STC oil manifold connections.

Align the injector with the oil manifold connections and install the injector into the cylinder head injector bore.

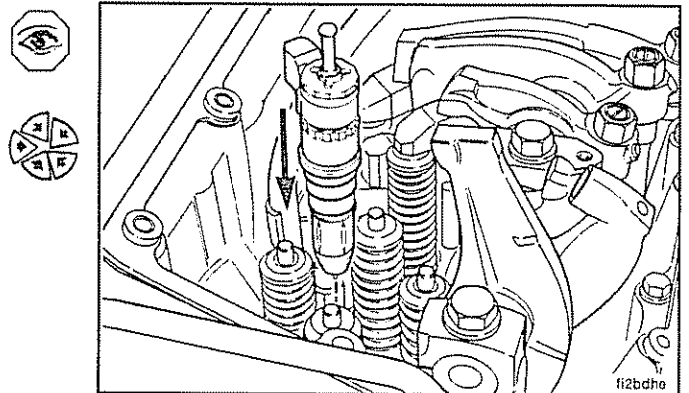

⚠ CAUTION ⚠

Be sure to place the instrument used to install the injectors on the top cap of the injector, not on the plunger or link. The plungers will be damaged.

Install a deep well socket 27 mm [1 1/16 in] over the top link of the injector. Use the socket so it will still rest completely on the top surface of the injector top cap to avoid bending the inner part of the top cap.

Use a clean, blunt instrument to seat the injector in the bore.

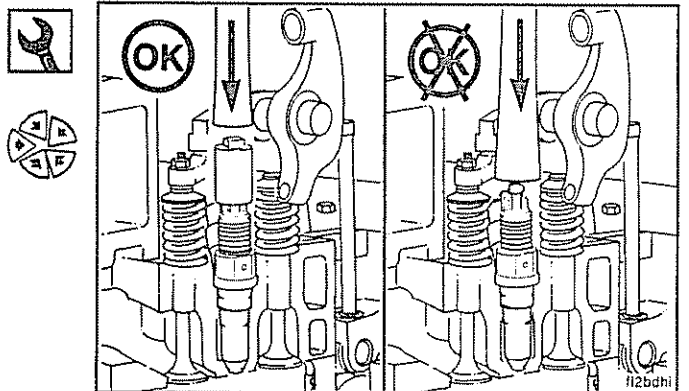

A "snap" will be heard and felt as the injector is seated.

If the injector does **not** seat, remove it and check the o-rings for damage. Replace damaged o-rings.

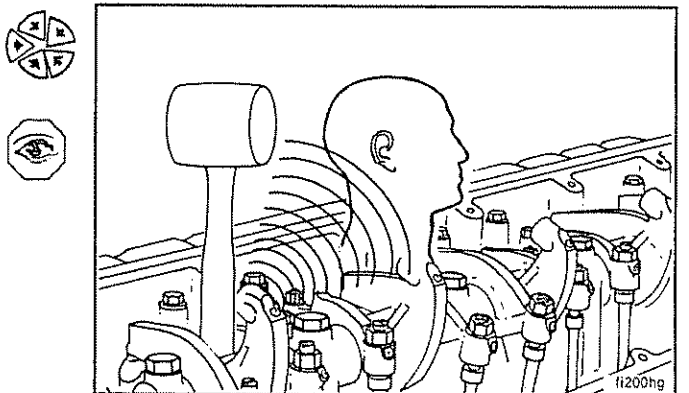

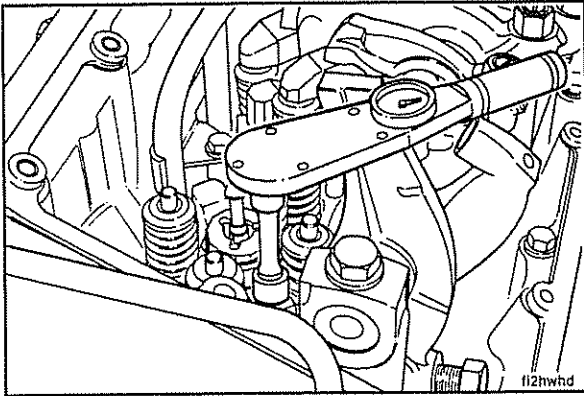

Install the injector hold down and capscrew.

Torque Value: 75 N•m [55 ft-lb]

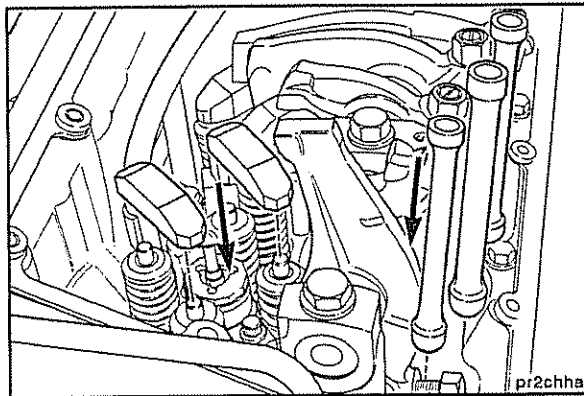

Install the crossheads on the valves.

Rotate the rocker levers down and install the push rods and push tubes.

NOTE: It is necessary to bar the engine over and install the push rods and push tubes as camshaft position allows.

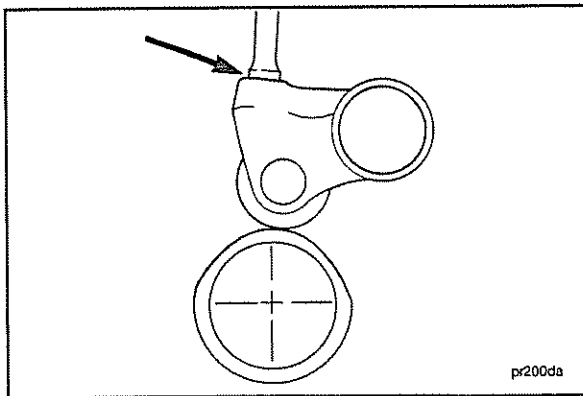

Make sure the push rods are properly seated in the cam follower sockets.

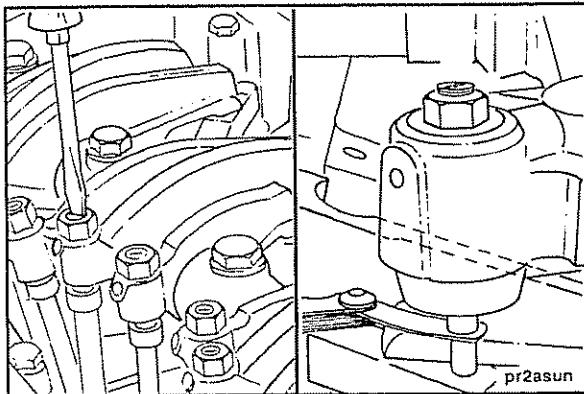

Turn the adjusting screw for each rocker lever in until it is properly seated in the push rod socket.

Adjust all valves and injectors. Refer to Overhead — Adjust (Section 6).



M11
Maintenance Procedures at 6,000 Hours

Inspect the rocker lever cover gasket for cuts or damage. If necessary, install a new gasket.

Install the rocker lever cover.

Install the 16 isolators and capscrews. Tighten the capscrews in the sequence shown.

Torque Value: 15 N•m [130 in-lb]

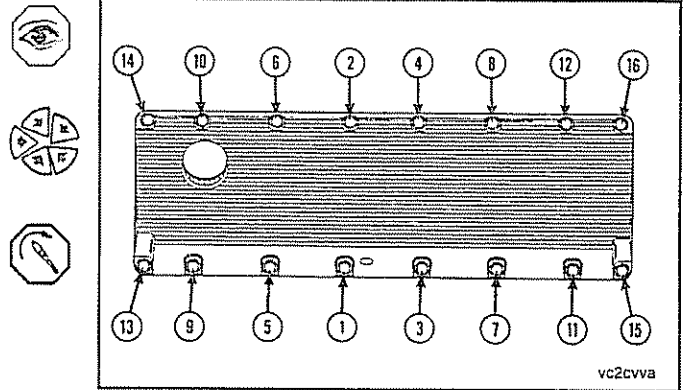

Fuel Pump

Remove

STC

Every 6,000 hours, clean and calibrate the fuel pump.

Calibration requires special equipment and **must** be done at a Cummins Authorized Repair Location.

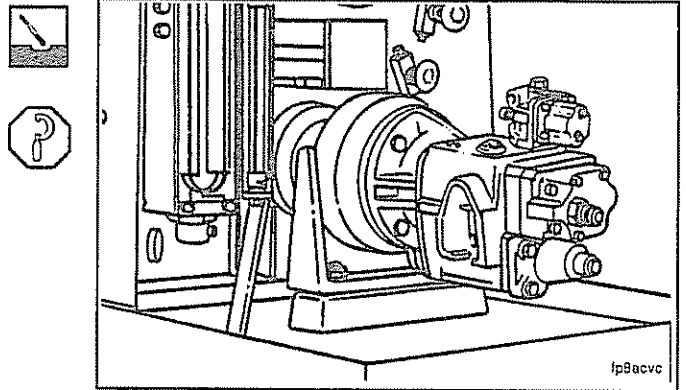

Disconnect the battery cables.

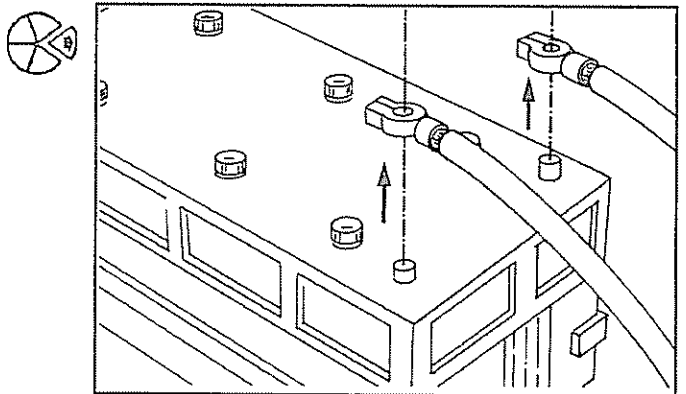

Clean the fuel pump and the surrounding area before removing it from the engine.

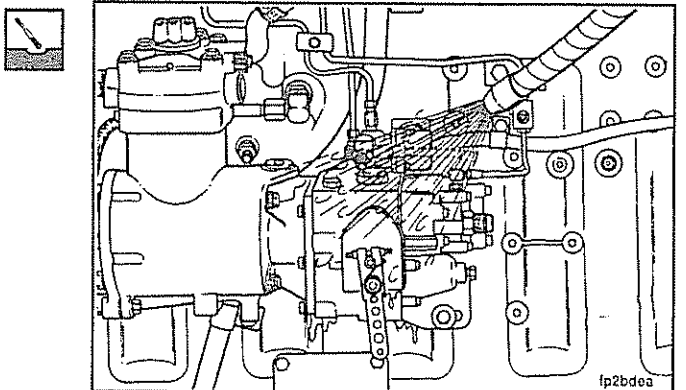

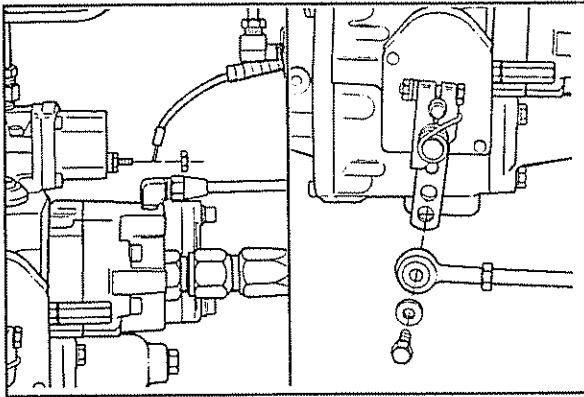

Remove the wire to the fuel shutoff valve.
Remove the linkage from the throttle lever.

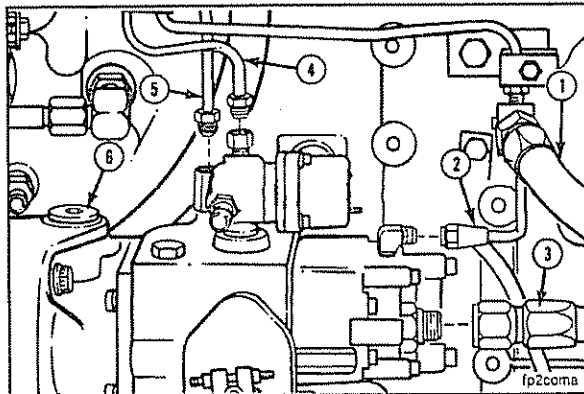

Remove the fuel tubing and air tube:

- Fuel drain line from the T-block connection (1)
- Gear pump cooling drain (2)
- Gear pump suction line (3)
- Fuel supply to the injectors (4)
- AFC air supply tube (5)
- Tachometer cable (if used) (6)

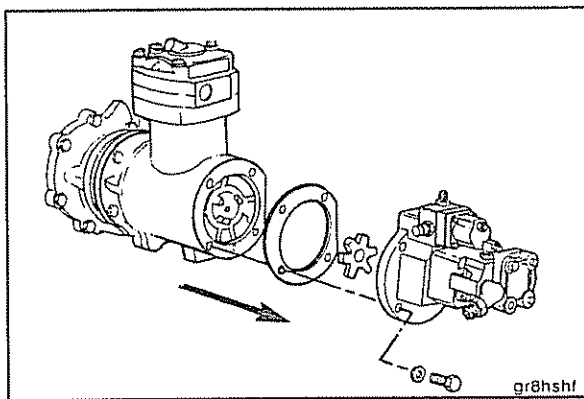

Remove the two fuel pump support bracket to cylinder block bracket mounting capscrews.

Remove the four fuel pump mounting capscrews and the fuel pump.

Remove the drive coupling.

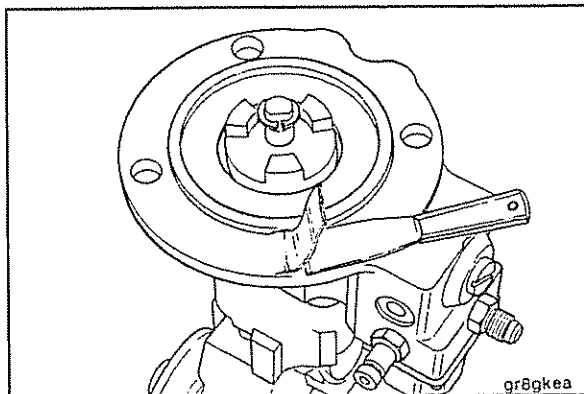

Clean the gasket surfaces of the pump support and the air compressor.



Inspect the mounting surfaces for damage.

Inspect the jaw coupling spider and the jaw coupling hub for damage or wear.

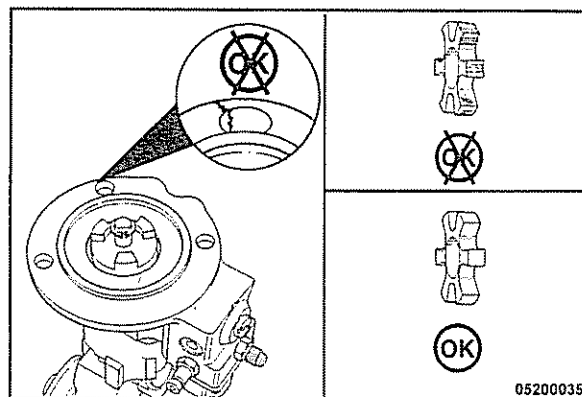

Install STC

Install the fuel pump drive coupling.

Use a new gasket when installing the fuel pump.

Install the four 12 point fuel pump mounting capscrews.

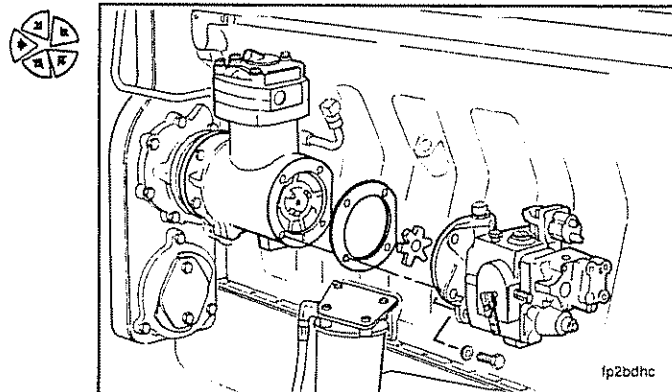

Install the two fuel pump support bracket capscrews to the cylinder block bracket. Tighten the four fuel pump mounting capscrews.

Torque Value: 47 N•m [35 ft-lb]

Tighten the two support bracket to cylinder block capscrews.

Torque Value: 47 N•m [35 ft-lb]

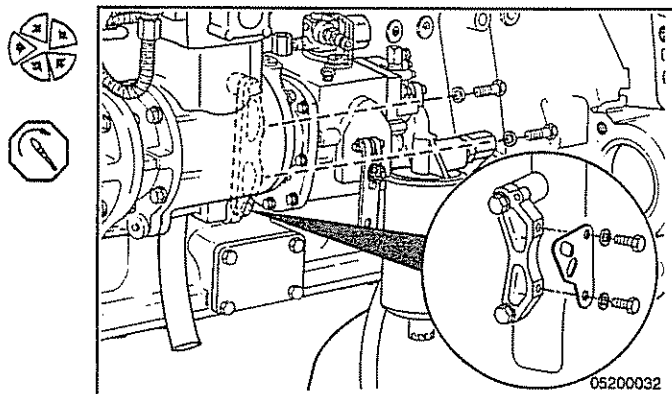

Install the AFC air tube and fuel tubing:

- Fuel drain from the T-block connection (1)
- Gear pump cooling drain (2)
- Gear pump suction line (3)
- Fuel supply to the injectors (4)
- AFC air supply tube (5)
- Tachometer cable (if used) (6)

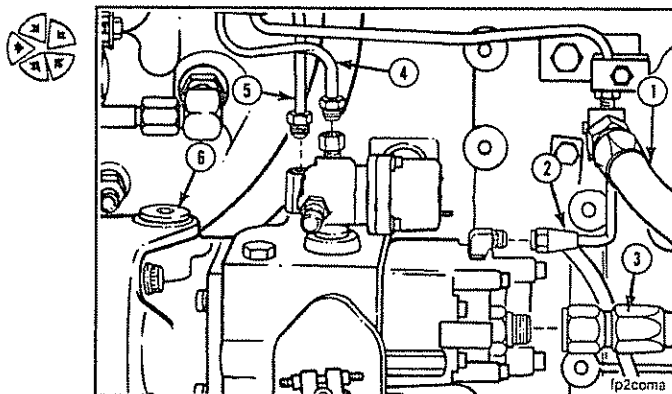

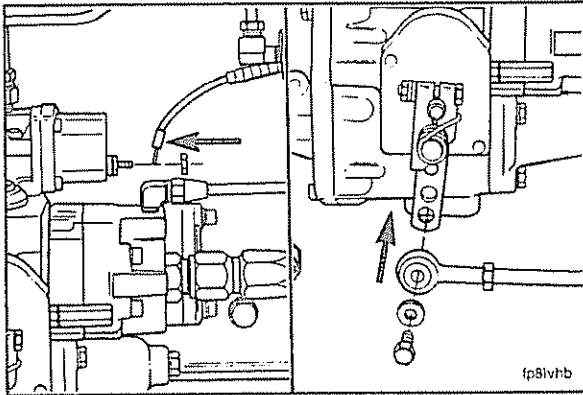

Install the electric wire to the fuel shutoff valve. The wire connection nut **must** be clean and tight.

Torque Value: 3 N•m [25 in-lb]

Install the linkage to the throttle lever.

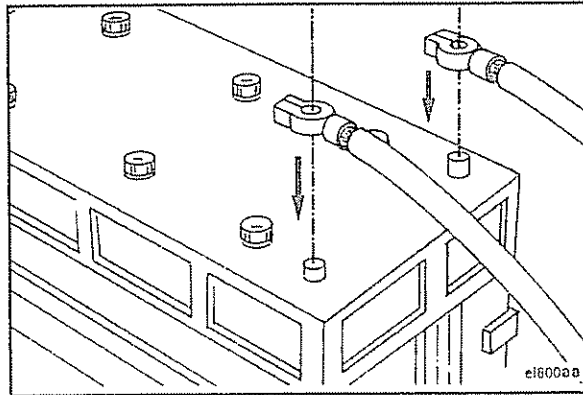

Install the battery cables.

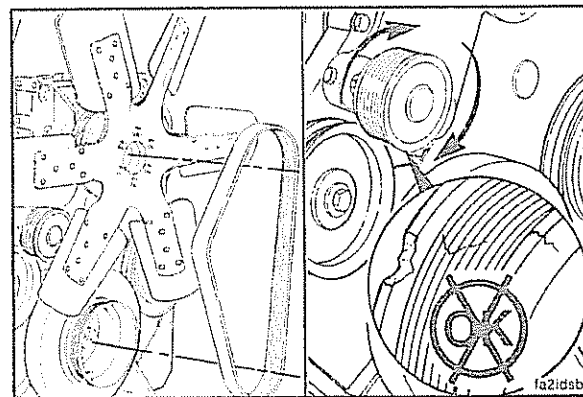

Fan Drive Idler Pulley Assembly Maintenance Check



Every 6,000 hours, measure the pulley end clearance.

Remove the fan drive belt.



Visually inspect the idler pulley for:

- Freedom of rotation
- Cracked, chipped or broken pulley grooves

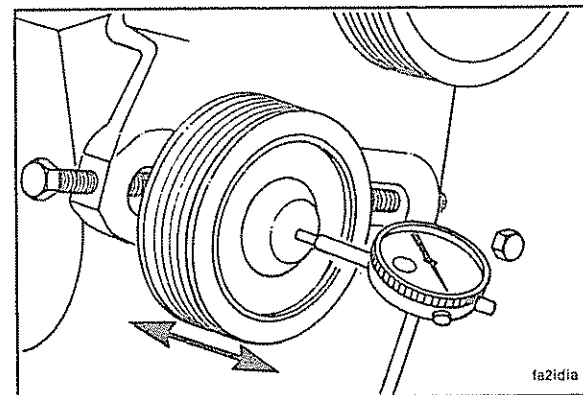

Measure the idler pulley end clearance.



Idler Pulley End Clearance		
mm		in
0.025	MIN	0.0010
0.250	MAX	0.0100

Replace or rebuild the idler pulley if the end clearance is **not** within these specifications. Refer to Section A for the replacement procedure. Refer to M11 Shop Manual, Bulletin No. 3666075, for rebuilding procedures..

Fan Hub, Belt Driven

Maintenance Check

Every 6,000 hours, measure the drive pulley flange end clearance.

Remove the fan drive belt.

Visually inspect the fan hub for:

- Freedom of rotation
- Cracks
- Grease seal leakage

Measure the fan hub end clearance.

Fan Hub End Clearance		
mm		in
0.08	MIN	0.003
0.41	MAX	0.016

Replace or rebuild the fan hub if the end clearance does **not** meet these specifications. Refer to Section A for the replacement procedure. Refer to the M11 Shop Manual, Bulletin No. 3666075, for rebuilding the fan hub.

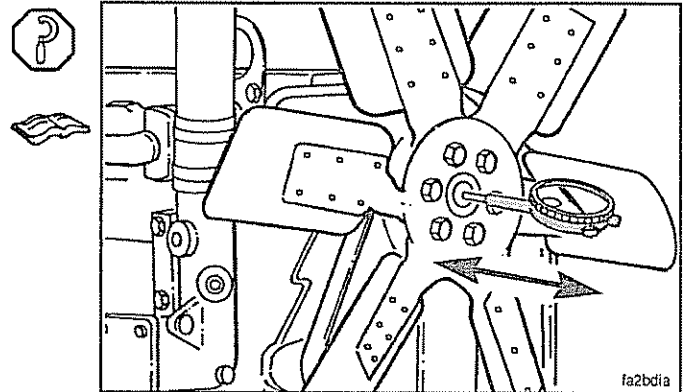
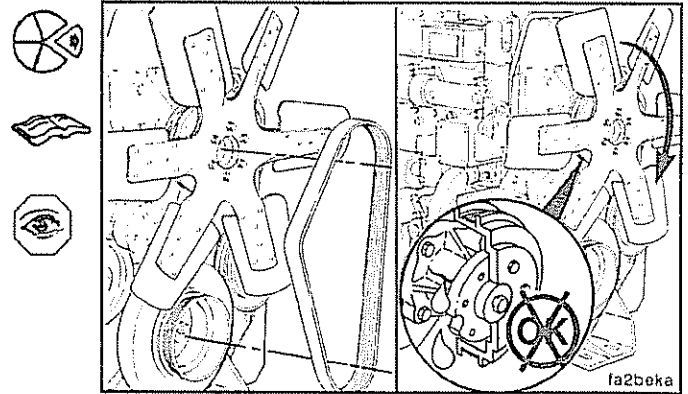

Turbocharger

Maintenance Check

Every 6,000 hours, inspect the turbocharger. Remove the air intake and the exhaust piping. Check the turbocharger as follows:

- Look for damaged or cracked compressor or turbine blades. Check to see that the turbocharger shaft spins freely.

If visual inspections or dimensional checks indicate a problem, contact a Cummins Authorized Repair Location for assistance. Refer to the model number on the turbocharger dataplate.

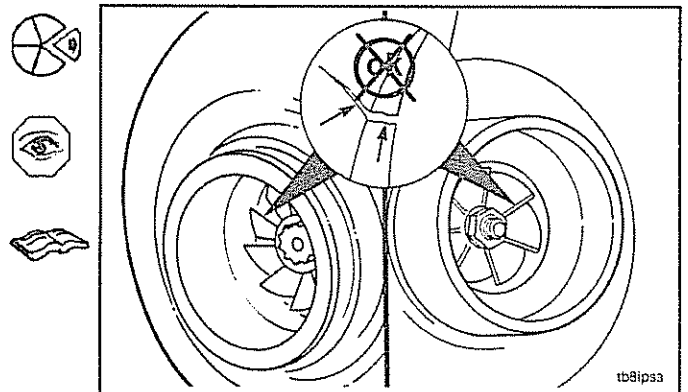

Radial Bearing Clearance — Checking

Remove the intake and exhaust pipes from the turbocharger.

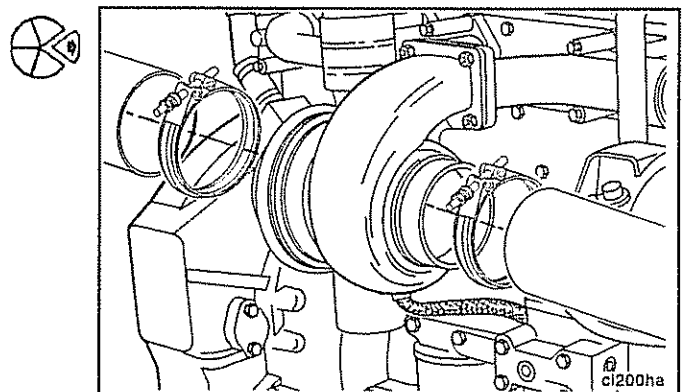

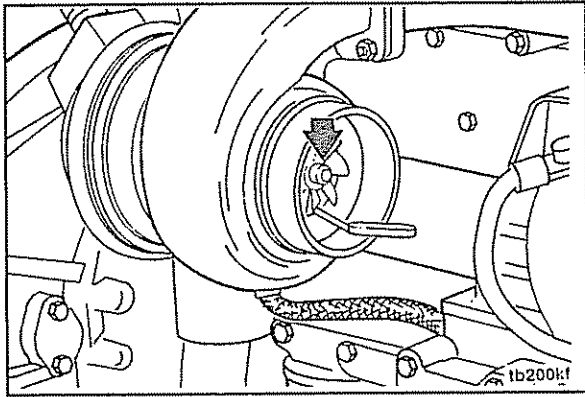

Use a narrow blade or a wire type feeler gauge to measure the clearance between the compressor wheel and housing.

Gently push the compressor wheel toward the compressor housing and gauge.

Record this clearance.

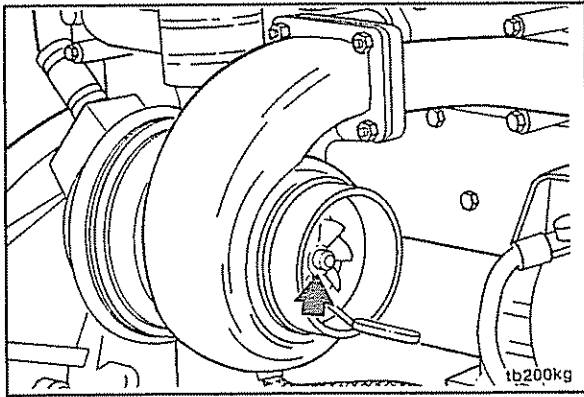

With the feeler gauge in the same location, gently push the compressor wheel away from the compressor housing and measure the clearance between the compressor wheel and housing.

Record this clearance.

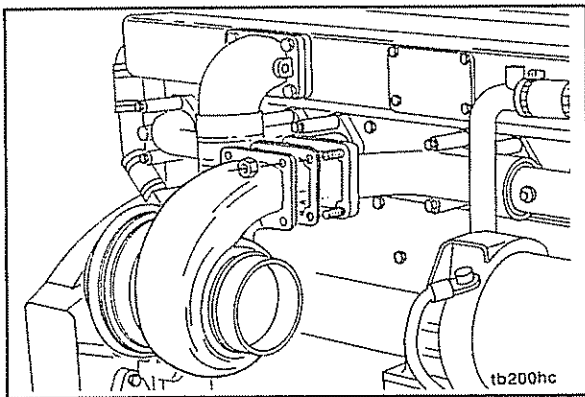

Subtract the smaller clearance from the larger clearance. This is the radial bearing clearance.

Radial Bearing Clearance		
mm		in
0.15	MIN	0.006
0.64	MAX	0.025

Replace the turbocharger if the radial bearing clearance does **not** meet the specifications. Refer to Section A for the replacement procedure.

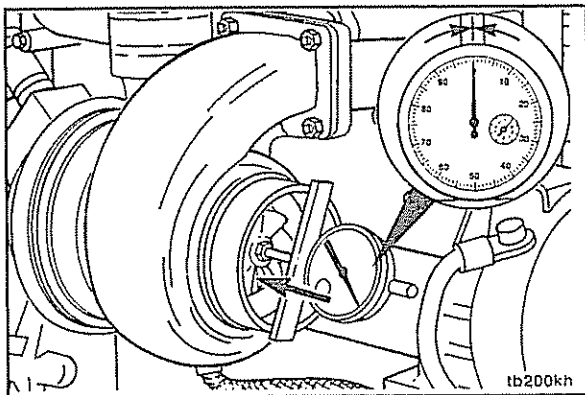

Axial Clearance — Checking

Use dial depth gauge, Part No. ST-537.

Push the rotor assembly away from the gauge.

Set the gauge on zero (0).

Push the rotor assembly toward the gauge and record the data.

Axial Clearance		
mm		in
0.038	MIN	0.0015
0.089	MAX	0.0035

Replace the turbocharger if the clearance does **not** meet the specifications. Refer to Section A for the replacement procedure.

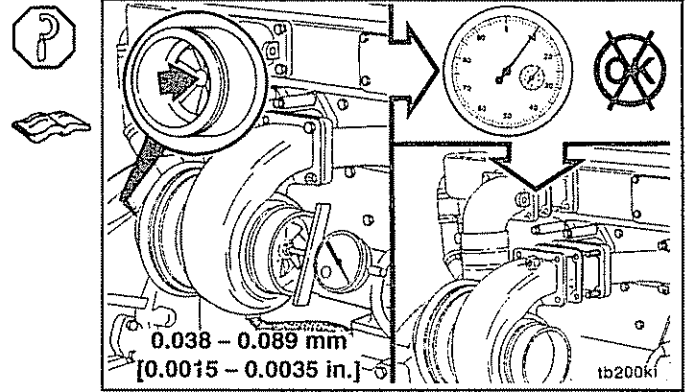

Install the exhaust pipe and tighten the clamp.

Install the intake pipe and tighten the clamp.

Torque Value: 8 N•m [72 in-lb]

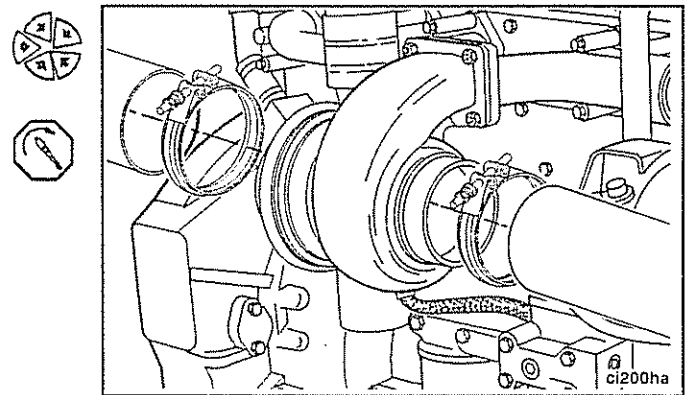

Air Compressor Maintenance

Maintenance Check

A complete inspection of the air compressor is required every 6,000 hours.

All air compressors have a small amount of oil carryover which lubricates the piston rings and moving parts. When this oil is exposed to normal air compressor operating temperatures over a period of time, it will form varnish or carbon deposits. If the following inspections are **not** done, the air compressor piston rings will be affected by high operating temperatures and pressures, and will **not** seal correctly.

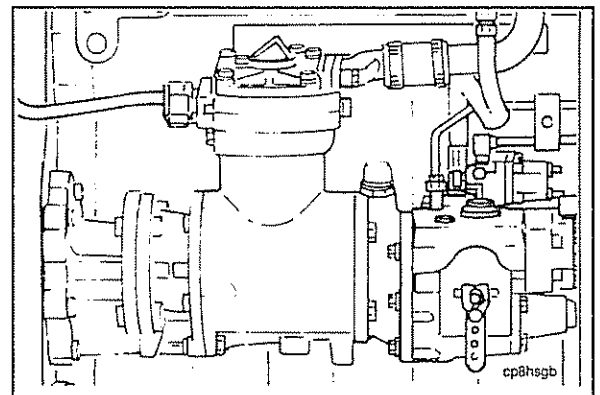

Air Compressor Discharge — Inspect

Shut off the engine.

Open the drain cock on the wet tank to release compressed air from the system.

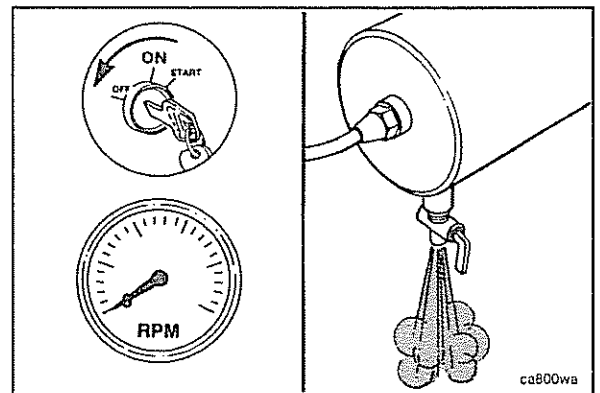

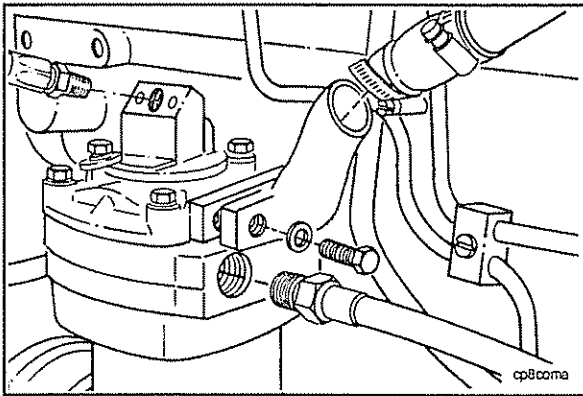

Remove the air inlet and outlet connections from the air compressor.

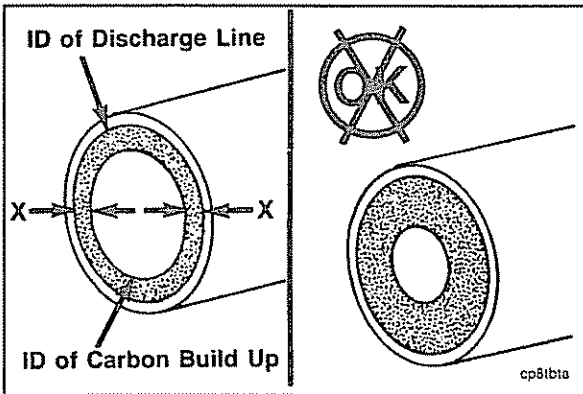

Measure the total carbon deposit thickness inside the air discharge line as shown.

NOTE: The carbon deposit thickness **must not** exceed 1.6 mm [0.06 (1/16)-inch].

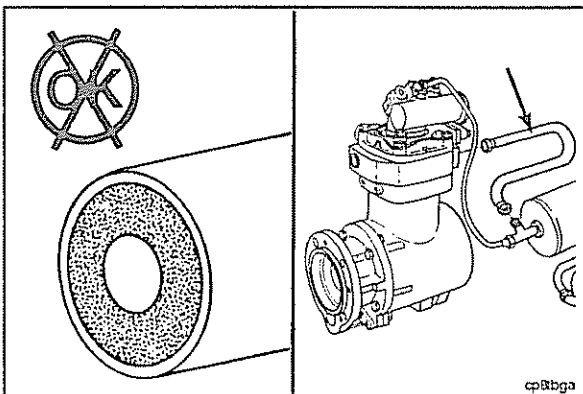

▲ WARNING ▲

The air discharge line must be capable of withstanding extreme heat and pressure to prevent personal injury and property damage. Refer to the manufacturer's specifications.



NOTE: If the total carbon deposit thickness exceeds specification, remove and clean, or replace the air discharge line. Refer to the manufacturer's material specifications.

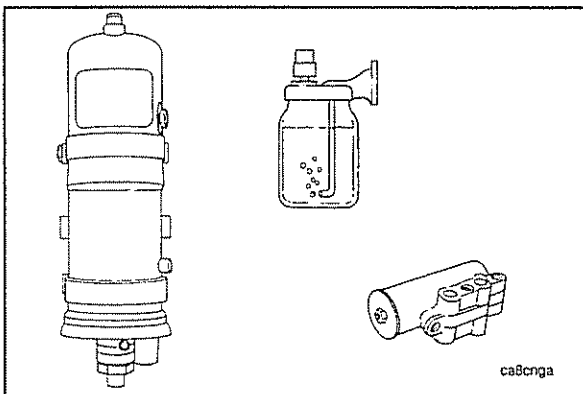

Inspect any air driers, spitter valves, pressure relief valves and alcohol injectors for carbon deposits or malfunctioning parts. Inspect for air leaks. Maintain and repair the parts according to the manufacturer's specifications.



Air Compressor Intake — Inspect



WARNING

Hold the unloader valve down when removing the capscrews. Personal injury can result from the sudden release of the spring loaded unloader valve.

Remove the capscrews, the lock washers and the flat washers that secure the unloader valve assembly to the cylinder head cover. Remove the unloader valve assembly and the spring from the cylinder head and the cover.

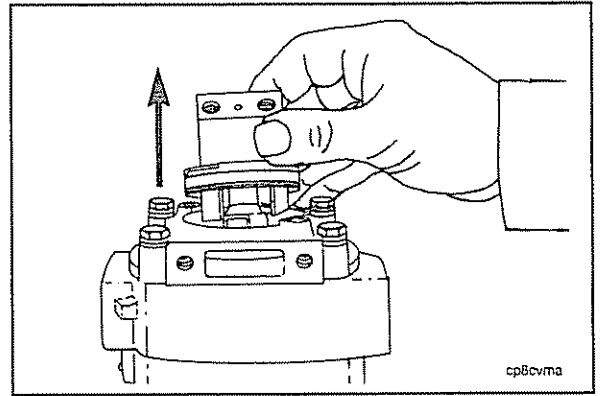

The air compressor is built with one of the two types of unloader valves. One is referred to as a flat hat type and the other is a three prong.

The cleaning procedure is the same for both.

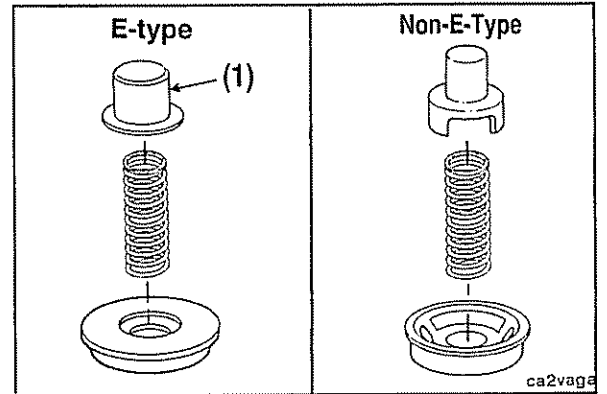

Visually inspect the unloader valve for carbon buildup. If carbon or heavy varnish is present, remove, clean and inspect the compressor head and the valve assembly. Replace parts as necessary. Refer to the Master Repair Manual Holset Air Compressors, Bulletin No. 3666121 for procedures or contact your nearest Cummins Authorized Repair Location:

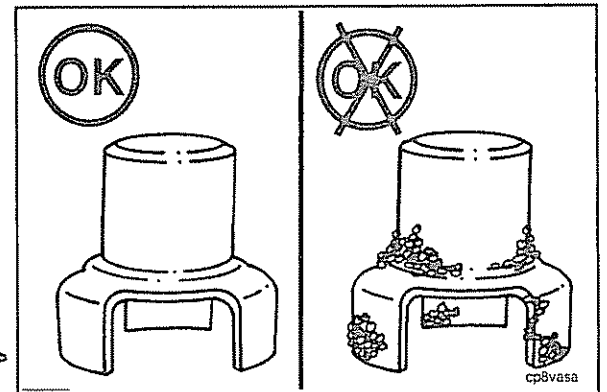

If the unloader valve is clean or only lightly varnished, install a new o-ring on the unloader body and a new rectangular seal inside the unloader body cavity.

The open side of the rectangular seal **must** face the top of the unloader body.

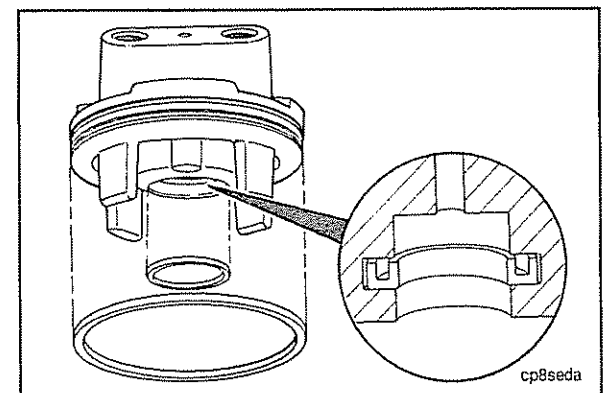

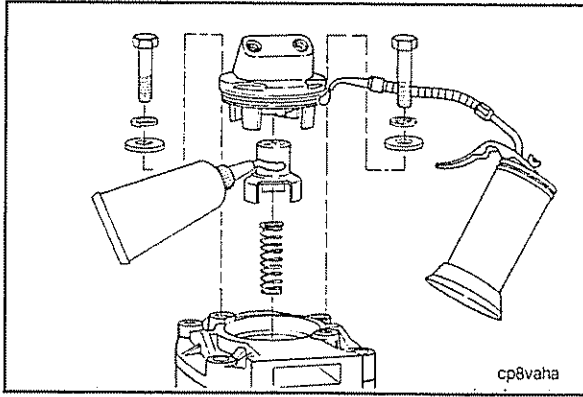

Lubricate the unloader cap with anti-seize compound. Lubricate the unloader body o-ring with engine oil. Assemble the unloader assembly to the cylinder head cover. Tighten the capscrews.

Torque Value: 14 N•m [10 ft-lb]

Section A - Adjustment, Repair and Replacement

Section Contents

	Page
Air Starting Motor	A-19
Coolant Thermostat	A-10
Install	A-11
Remove	A-10
Drive Belt, Alternator	A-2
Adjust	A-2
Install	A-4
Remove	A-3
Drive Belt, Cooling Fan	A-1
Adjust	A-1
Install	A-2
Remove	A-1
Engine Storage - Long Term	A-19
Fan Drive Idler Pulley Assembly	A-12
Install	A-13
Remove	A-12
Fan Hub, Belt Driven	A-14
Install	A-15
Remove	A-14
Turbocharger	A-16
Install	A-17
Remove	A-16
Water Pump	A-4
Install	A-7
Remove	A-4



THIS PAGE LEFT INTENTIONALLY BLANK.

Drive Belt, Cooling Fan

Adjust

Do **not** adjust belt tension to full value with the adjusting screw. Belt tension can increase when the locknut is tightened and cause reduced belt and bearing life.

- Loosen the idler pulley shaft locknut.
- Use belt tension gauge, Part No. ST-1293, to adjust the belt to the correct tension. Refer to the Belt Tension Chart (Section V) for the correct value.

- Tighten the idler pulley shaft locknut.

Torque Value: 190 N•m [140 ft-lb]

- Check the belt tension again to make sure the belt is **not** too tight.

Remove

Loosen the fan idler pulley shaft locknut.

Turn the adjusting screw **counterclockwise** to release the belt tension.

Move the fan idler pulley and fan pulley centers as close as possible. The belt can then be removed without excessive force.

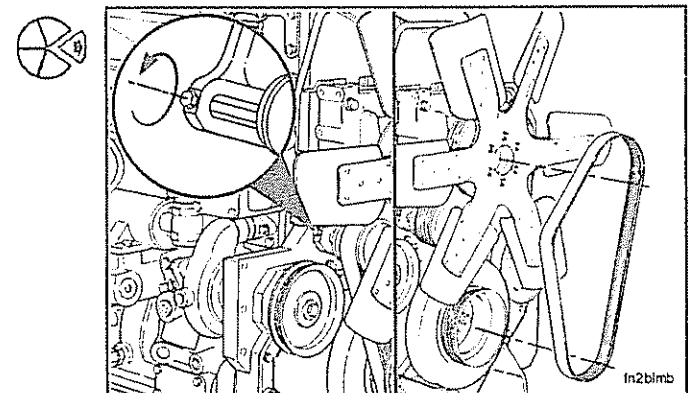
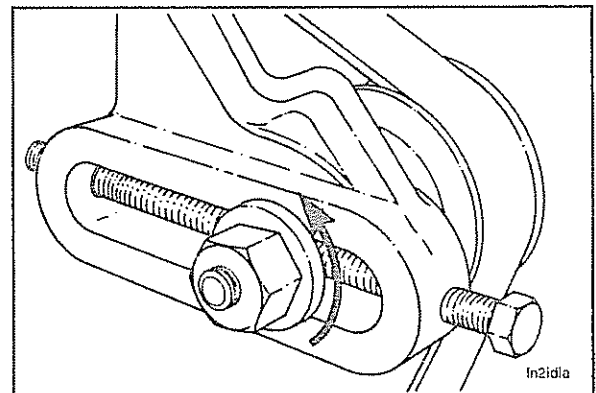
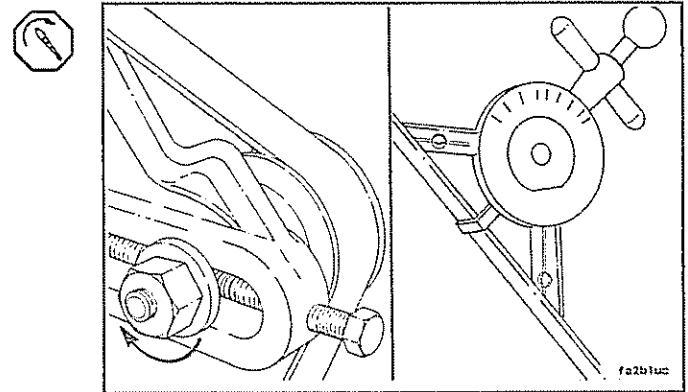
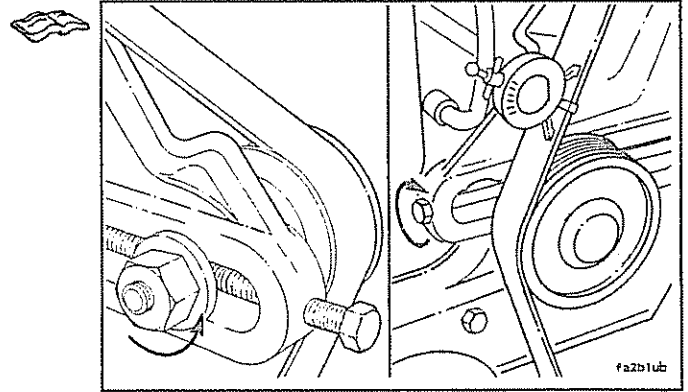

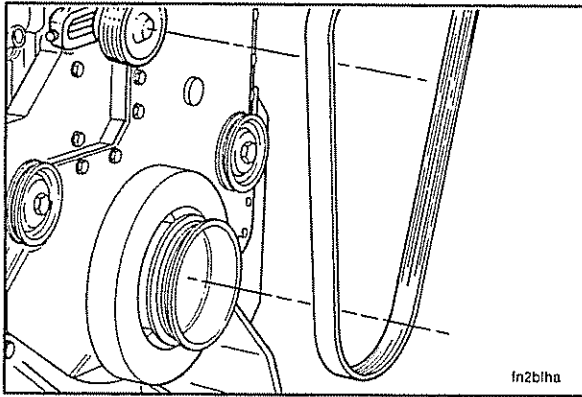

Install

CAUTION

To prevent damage to the pulley and new belt, do not roll the belt over the pulley or pry it on with a tool.

Install a new fan belt on the pulleys.

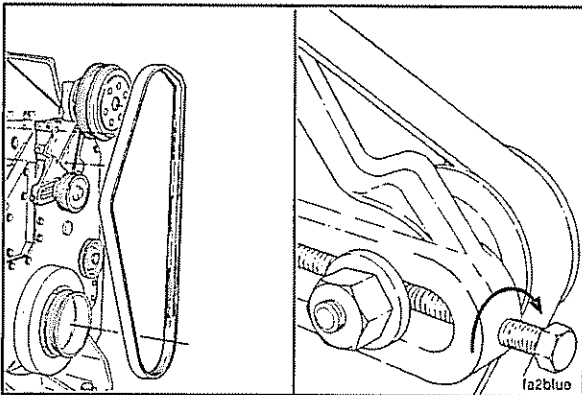

Use belt tension gauge, Part No. ST-1293, to measure the belt tension. Refer to Drive Belt Tension in Section V for the correct belt tension for the belt you are installing.

Turn the adjusting screw to adjust the belt tension.

NOTE: A belt is considered used if it has been in operation 10 minutes or longer. If used belt tension is below the minimum value, tighten the belt to the maximum value. Replace the belt if it will **not** maintain correct tension.

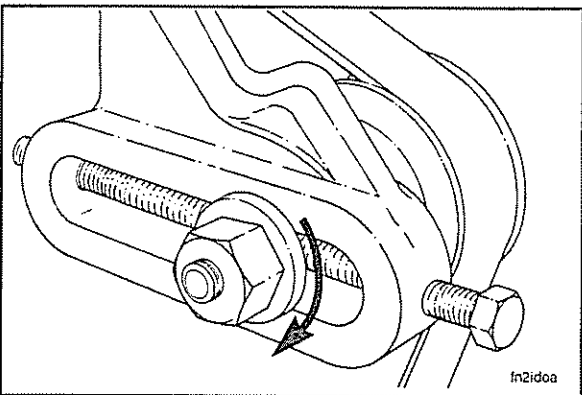

Tighten the idler pulley shaft locknut.

Torque Value: 190 N•m [140 ft-lb]

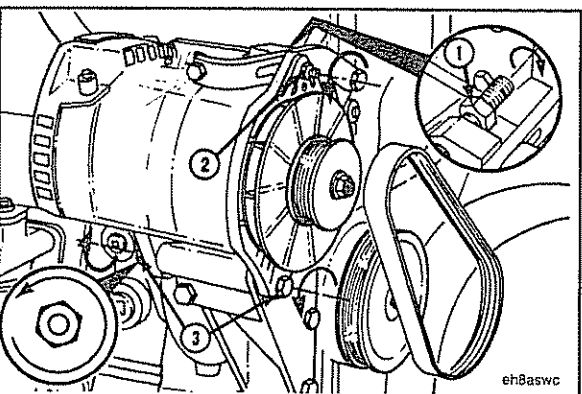

Drive Belt, Alternator

Adjust

Loosen the adjusting screw locknut (1).

Loosen the adjustment link locking capscrew (2).

Loosen the pivot capscrew and nut (3).

M11
Section A - Adjustment, Repair and Replacement

Use belt tension gauge, Part No. ST-1293, to measure belt tension.

Turn the alternator adjusting screw **clockwise** to tighten the belt. Refer to Drive Belt Tension in Section V for the correct belt tension for the belt you are adjusting.

NOTE: A belt is considered used if it has been in operation for 10 minutes or longer.

NOTE: If the alternator drive belt has more than five ribs, refer to the belt tension chart in Section V for correct belt adjustment.

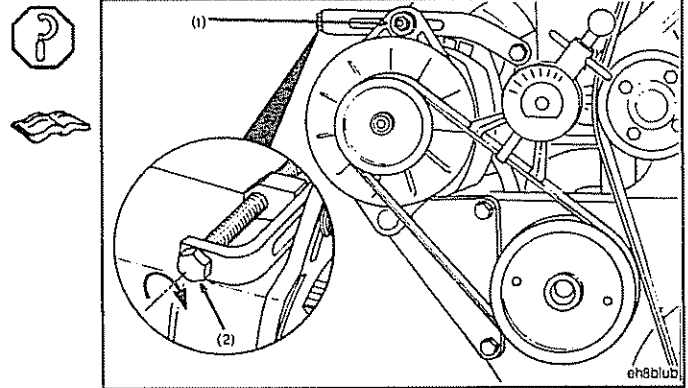

Tighten the adjusting screw locknut (2) against the retainer.
Tighten the adjustment link locking capscrew (3).

Torque Value: 80 N•m [60 ft-lb]

Tighten the pivot capscrew (4) and nut (5).

Torque Value: 47 N•m [35 ft-lb]

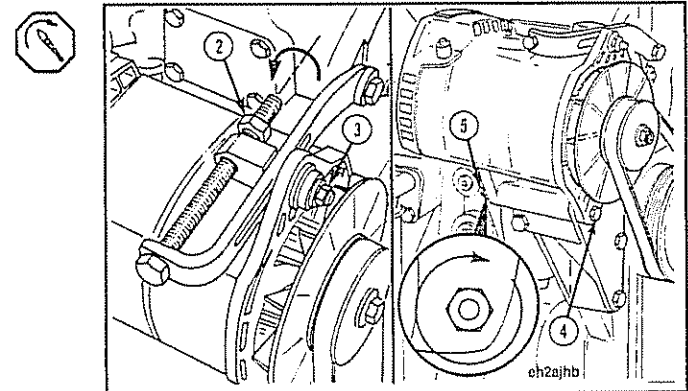

Remove

Loosen the adjusting screw locknut (1).

Loosen the adjustment link locking capscrew (2).

Loosen the alternator mounting capscrew (3).

Turn the adjusting screw (4) **counterclockwise** to release tension.

Remove the alternator belt.

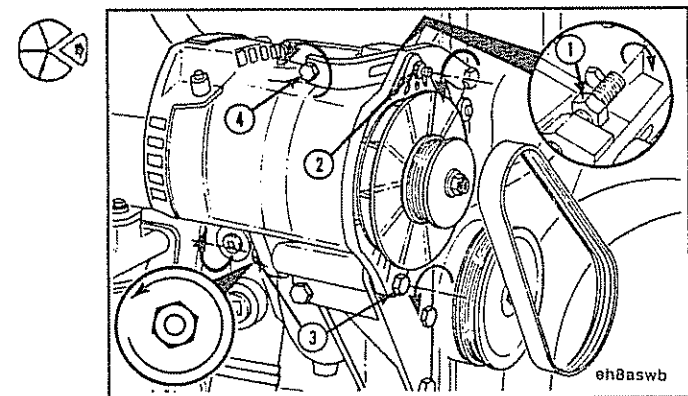

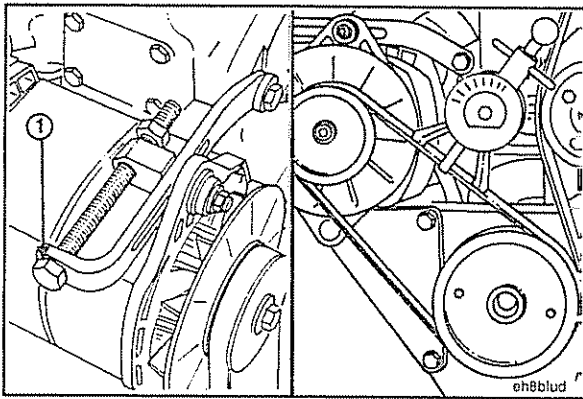

Install

Install a new belt on the water pump and alternator pulleys. To prevent damage, do **not** roll a belt over the pulley or pry it on with a tool.



Turn the adjusting screw (1) **clockwise** to increase the belt tension.



Use belt tension gauge, Part No. ST-1293, to measure the belt tension. Refer to Drive Belt Tension in Section V for the correct tension value for the belt you are installing.

NOTE: A belt is considered used if it has been in operation for 10 minutes or longer.

NOTE: If the alternator drive belt has more than five ribs, refer to the belt tension chart in Section V for correct belt adjustment.

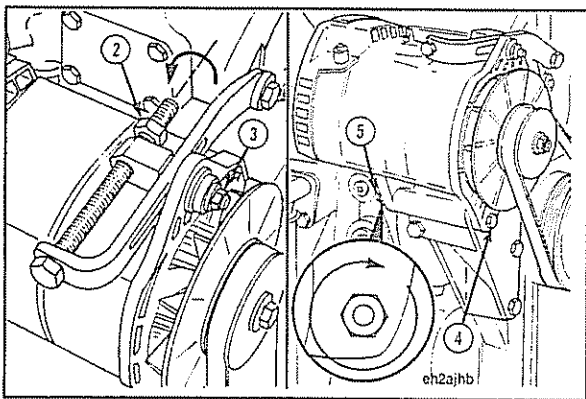

Tighten the adjusting screw locknut (2) against the retainer.

Tighten the adjustment link locking capscrew (3).

Torque Value: 80 N•m [60 ft-lb]

Tighten the pivot capscrew (4) and nut (5).

Torque Value: 47 N•m [35 ft-lb]

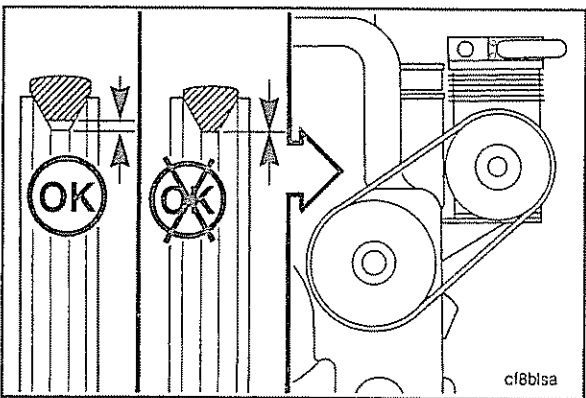

Belts **must not** touch the bottom of the pulley grooves, nor **must** they protrude over 3 mm [3/32-inch] above the top edge of the groove.

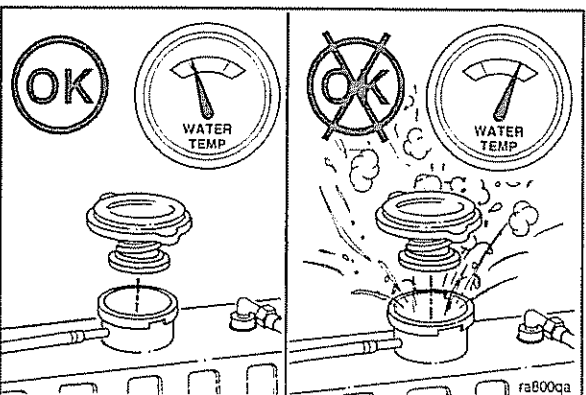

Water Pump

Remove



WARNING

Do not remove the radiator cap from a hot engine. Wait until the temperature is below 50°C [120°F] before removing the coolant system pressure cap. Failure to do so can cause serious personal injury from heated coolant spray.

Remove the radiator cap after the engine is cool.

Drain the cooling system as follows:

- Open the radiator draincock.
- Remove the lower radiator hose from the radiator and water pump.

NOTE: If the coolant is **not** going to be reused, dispose of used coolant and antifreeze in accordance with federal, state, and local regulations.

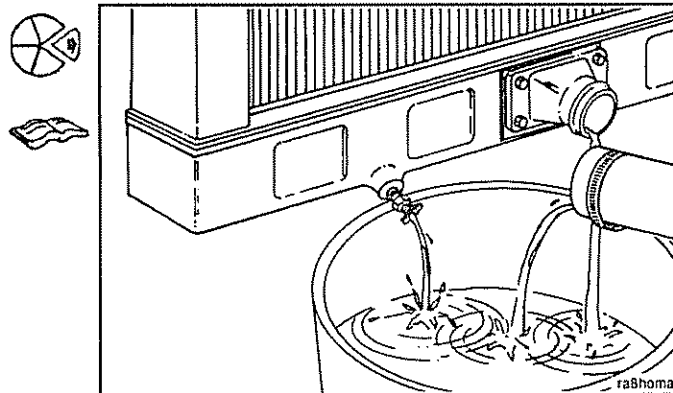

Remove the alternator drive belt.

Remove the water pump pulley retaining capscrew.

Use the standard pulley puller, Part No. ST-647, and two 5/16 X 18 X 2 capscrews to remove the pulley.

NOTE: Be sure the puller capscrews are threaded all the way through the puller before applying pressure to the puller screw.

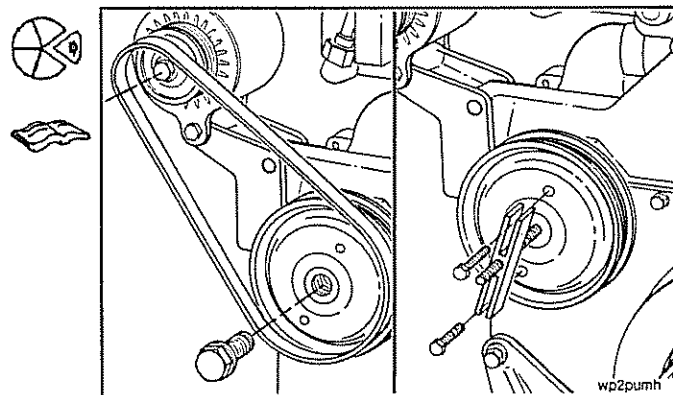

Remove the alternator.

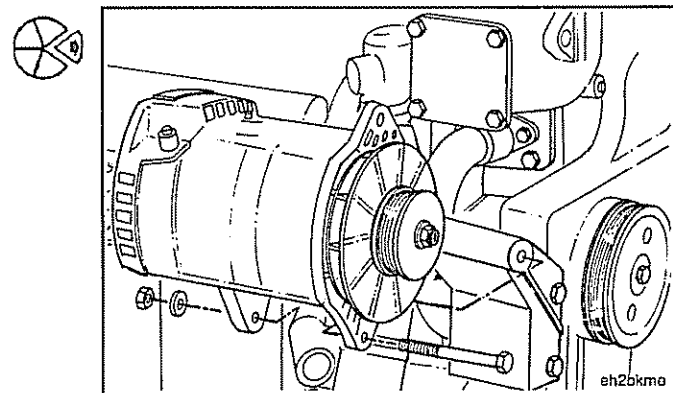

Remove the dust seal.

Remove the five water pump oil seal capscrews, clamping ring, oil seal and gasket.

NOTE: Remove the dust seal as the seal carrier is removed or use a heel bar, or similar tool, to pry the dust seal away from the seal case. Then remove the dust seal by hand.

Discard the oil seal and dust seal.

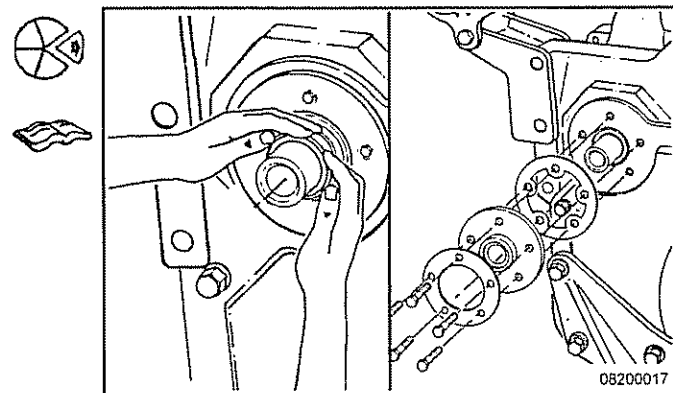

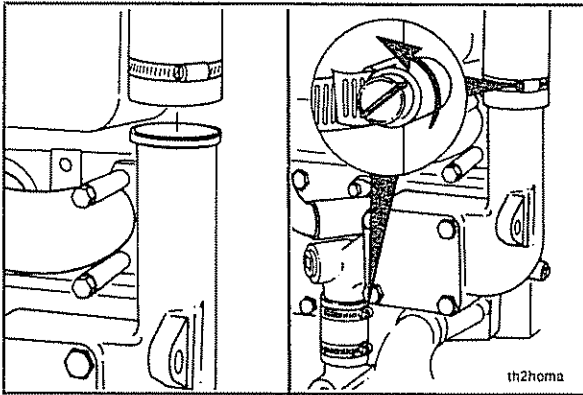

Remove the upper radiator hose from the thermostat housing.

Loosen the coolant bypass hose clamps.

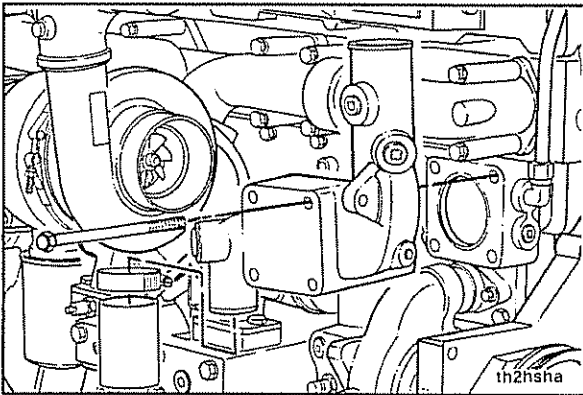

Remove the four thermostat housing mounting capscrews and the thermostat housing.

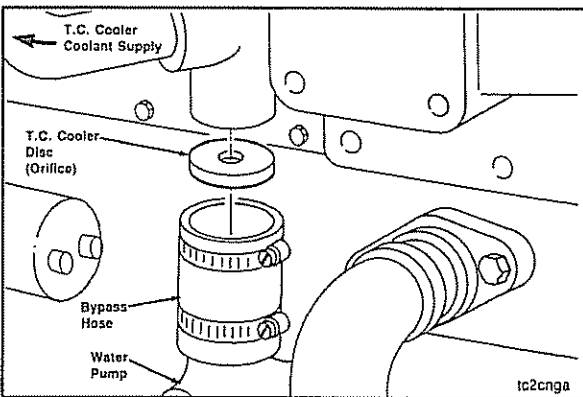

The coolant flow to provide cooling to the torque converter (if equipped) is achieved using a disc inside the coolant bypass hose to direct engine coolant to the inlet side of the torque converter cooler.

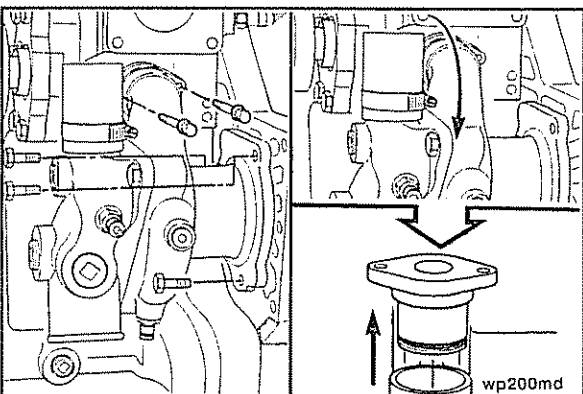

Remove the two water pump water transfer connection capscrews.

Remove the three water pump mounting capscrews.

Rotate the water pump outward so the water transfer connection can be removed from the water pump.

Remove the water transfer connection from the water pump.

M11
Section A - Adjustment, Repair and Replacement

Remove the water pump. Twist the pump outward from the top and angle the rear of the pump downward as it is being removed to allow the pump to pass the thermostat housing support.

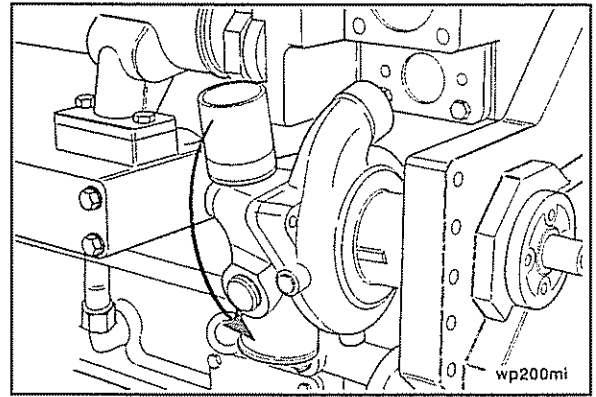

Install

Install a new o-ring on the water pump mounting flange.

NOTE: The water pump **must** be twisted outward from the top until the transfer outlet clears the thermostat housing support during installation.

Install the water pump.

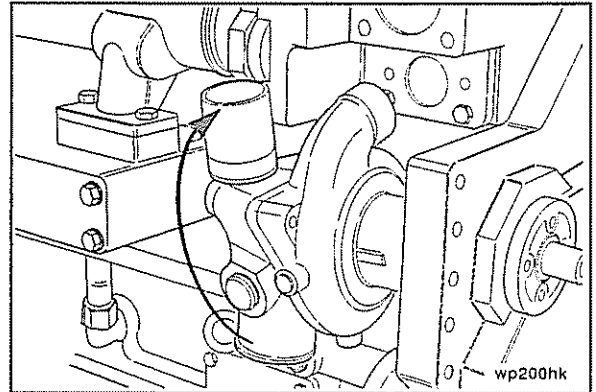

Install a new o-ring on the water pump water transfer tube.

Install the connection into the water pump.

Twist the water pump inward and install the three water pump mounting capscrews.

Torque Value: 47 N•m [35 ft-lb]

Install a new gasket on the water pump water transfer connection. Install and tighten the water transfer connection capscrews.

Torque Value: 25 N•m [18 ft-lb]

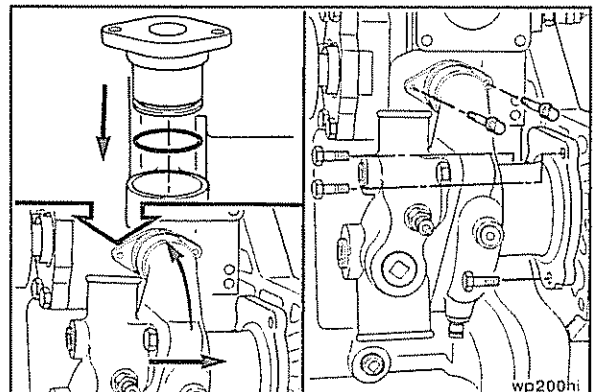

If the engine is equipped with a torque convertor cooler, install the disc in the bypass hose before installing the thermostat housing.

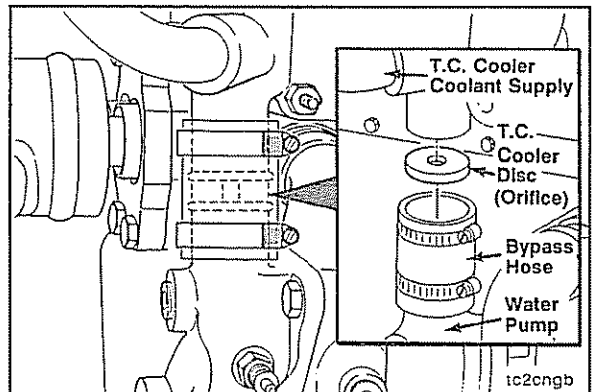

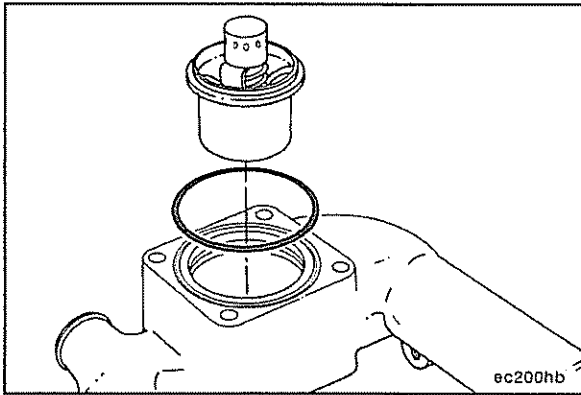

Install the thermostat in the housing.

Install a new seal in the groove on the thermostat housing mounting surface.

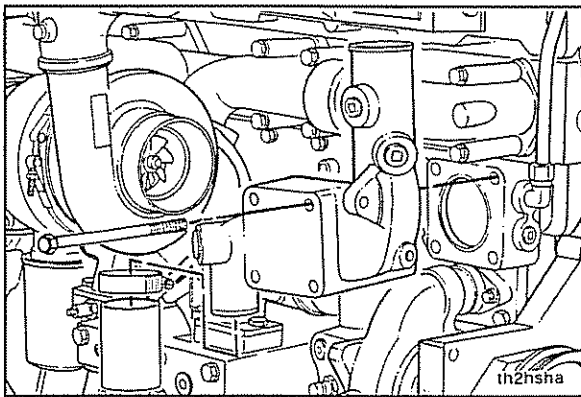

Install the hose on the thermostat housing bypass outlet.

Install the thermostat housing and four mounting capscrews.



Torque Value: 54 N•m [40 ft-lb]

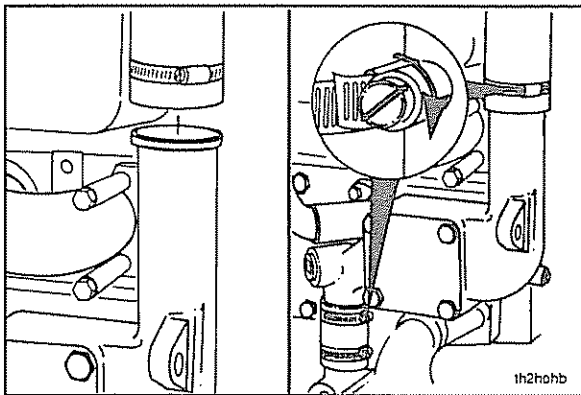

Equally space the bypass hose over the water pump connection and thermostat housing connection, and tighten the bypass hose clamps.

Torque Value: 3 N•m [30 in-lb]



Install the upper radiator hose. Refer to the manufacturer's specifications for the correct torque value.



Install the lower radiator hose. Refer to the manufacturer's specifications for the correct torque value.

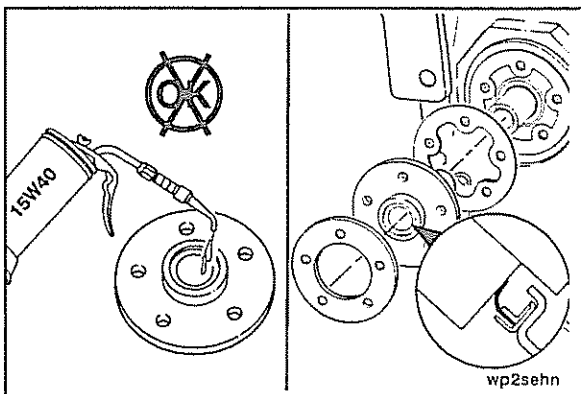

The oil seal **must** be installed with the lip of the seal and the shaft clean and dry. Do **not** lubricate. The yellow dust lip **must** be facing out.

Install the new gasket and oil seal. Use the installation sleeve provided with the new seal to install the seal.

The capscrew threads **must** be coated with thread sealant, Part No. 3823494, to prevent oil leakage.

Torque Value: Step 1 7 N•m [60 in-lb]
Step 2 20 N•m [180 in-lb]

M11
Section A - Adjustment, Repair and Replacement

Place a light film of oil or antifreeze on the inside diameter of the oil seal dust seal.

Install the dust seal onto the shaft with the larger outside diameter facing towards the engine.

Push the dust seal back by hand on the shaft until the entire dust seal contacts the oil seal case.

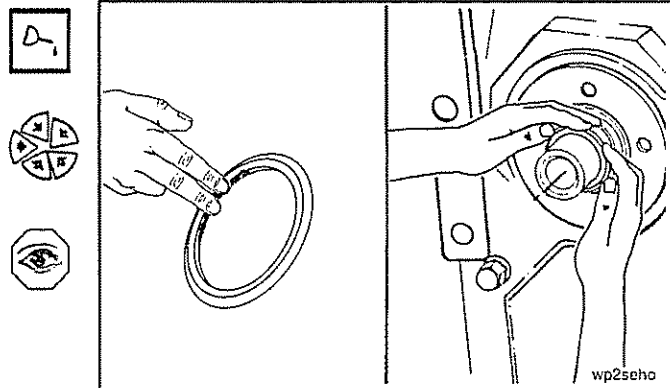

Use the Part No. 3377401 Pulley Pusher Adapter (1) and the Part No. 3376326 Pulley Pusher (2) to install the pulley.

Install the capscrew in the shaft.

Torque Value: 75 N•m [55 ft-lb]

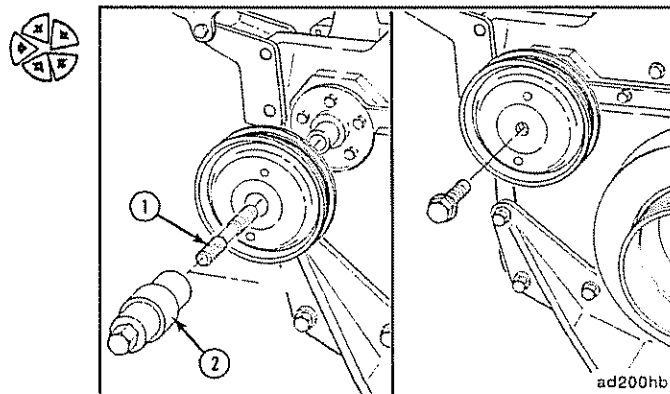

Install the alternator.

Install and adjust the alternator drive belt.

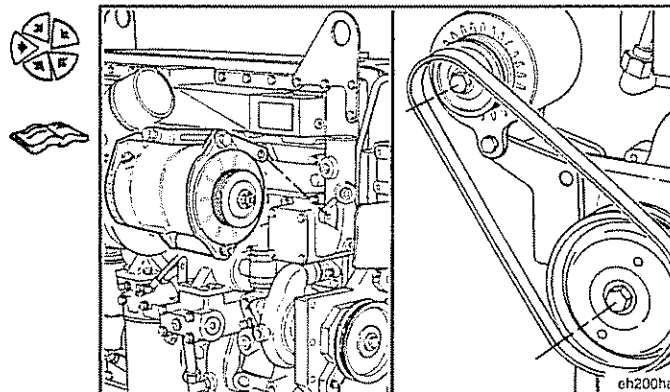

Close the radiator draincock and install the lower radiator hose.

Tighten the hose clamp(s).

Refer to the manufacturer's specifications for the correct torque value.

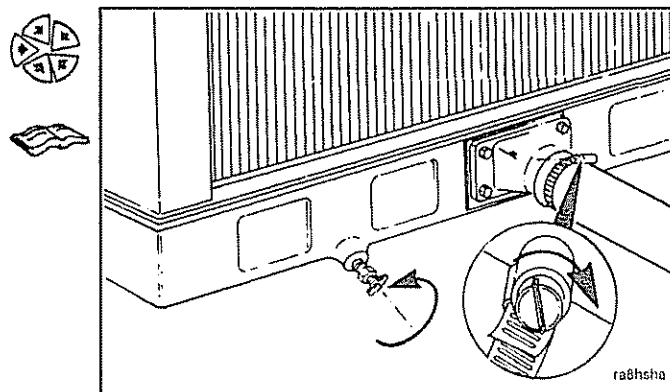

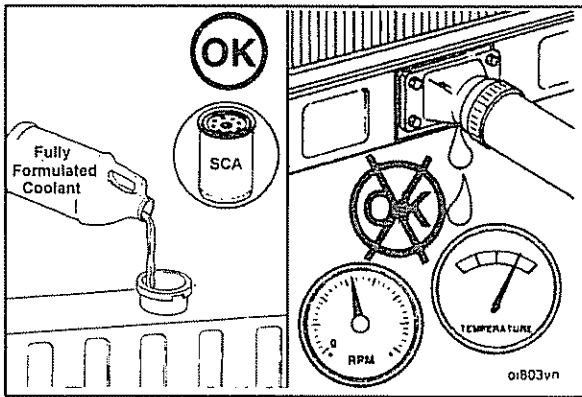

The correct concentration of coolant additives **must** be used in the cooling system. Refer to Section V.



Fill the cooling system.

Operate the engine until it reaches a temperature of 80°C [180°F] and check for coolant leaks.

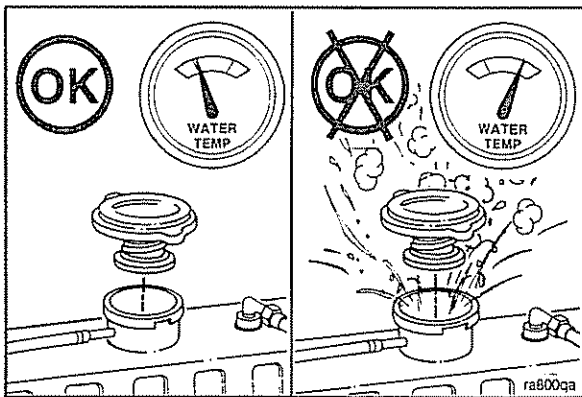

Coolant Thermostat

Remove



WARNING

Do not remove the radiator cap from a hot engine. Wait until the temperature is below 50°C [120°F] before removing the coolant system pressure cap. Failure to do so can cause serious personal injury from heated coolant spray.

Remove the radiator cap after the engine is cool.

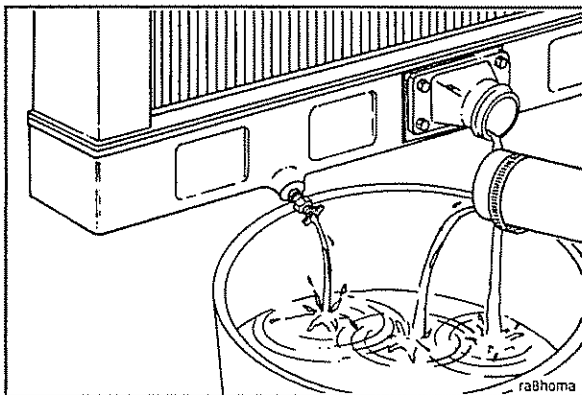

NOTE: If the coolant will **not** be reused, dispose of the coolant in accordance with federal, state, and local environmental regulations.

Drain the cooling system as follows:

- Open the radiator draincock.
- Remove the lower radiator hose.

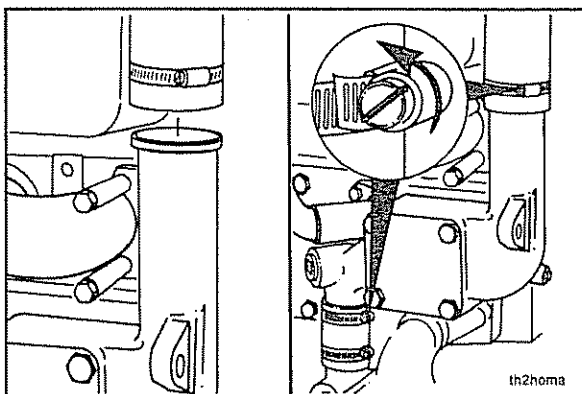

Remove the upper radiator hose from the thermostat housing.

Loosen the coolant bypass hose clamps.

NOTE: Some models could have a converter cooler disc located in the bypass hose.

M11
Section A - Adjustment, Repair and Replacement

Remove the four thermostat housing mounting capscrews and the thermostat housing.

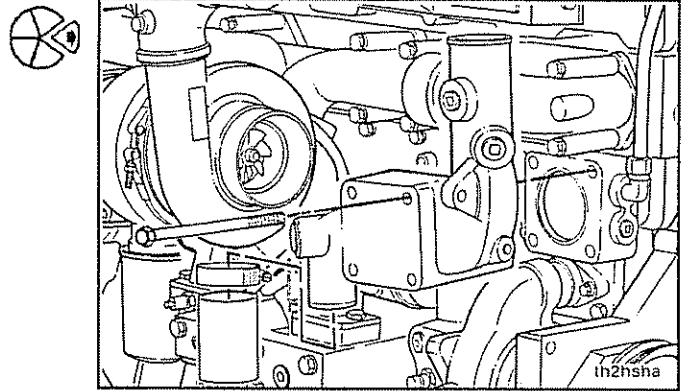

Remove the thermostat from the housing.

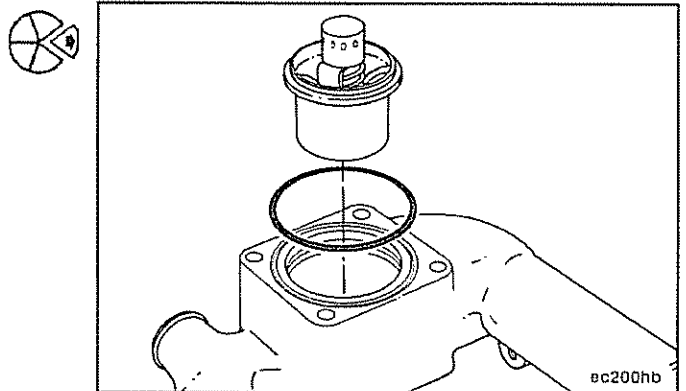

Install

Install the thermostat in the housing.

Install a new seal in the groove on the thermostat housing mounting surface.

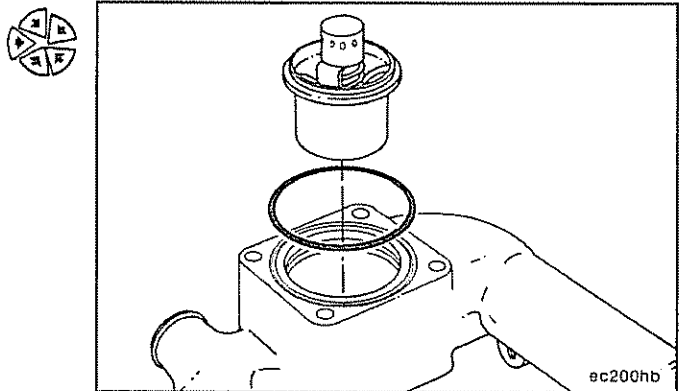

Install the hose on the thermostat housing bypass outlet.
Install the thermostat housing and four mounting capscrews.

Torque Value: 54 N•m [40 ft-lb]

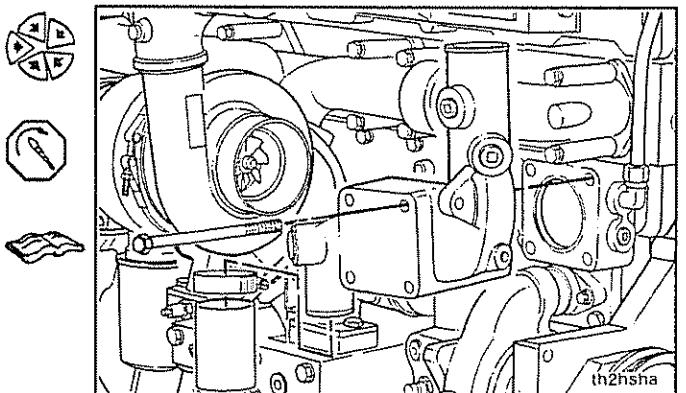

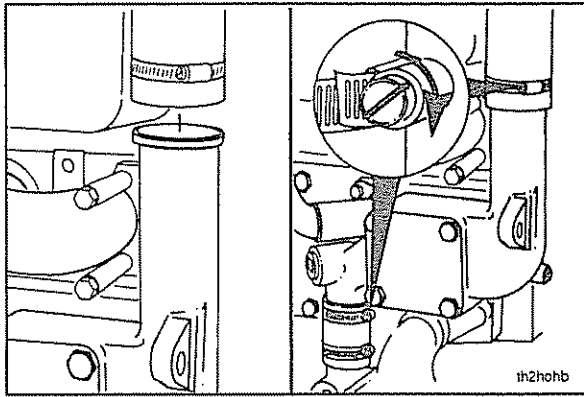

Install the upper radiator hose to the thermostat housing outlet. Refer to the manufacturer's specifications for the correct torque value.



Tighten the coolant bypass hose clamps.

Torque Value: 3 N•m [30 in-lb]

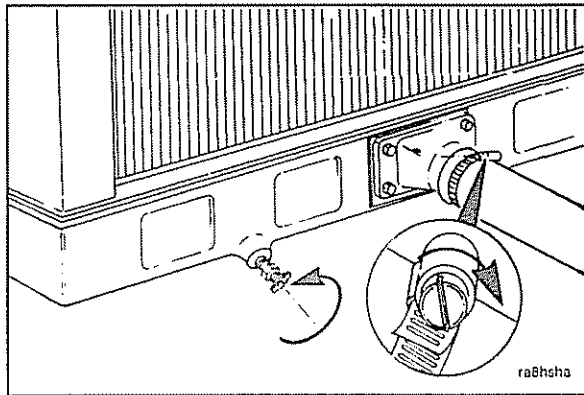

Close the radiator draincock and install the lower radiator hose.

Tighten the hose clamp. Refer to the manufacturer's specifications for the correct torque value.

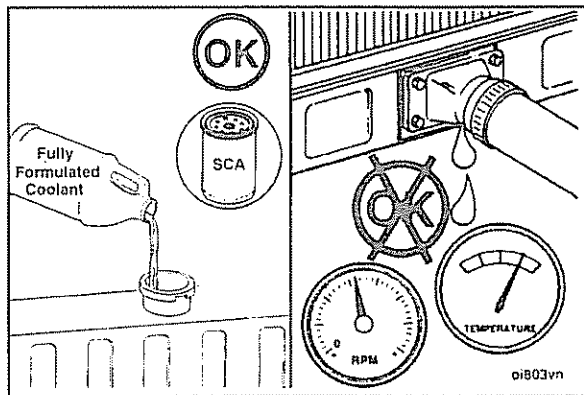

The correct concentration of coolant additives **must** be used in the cooling system. Refer to Section V.



Fill the cooling system.

Operate the engine until it reaches a temperature of 80°C [180°F] and check for coolant leaks.

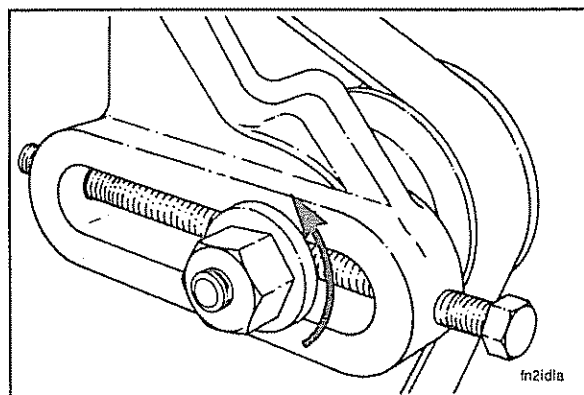

Fan Drive Idler Pulley Assembly

Remove

Loosen the fan idler pulley shaft locknut.

M11
Section A - Adjustment, Repair and Replacement

Loosen the adjusting mechanism and move the fan idler pulley and fan pulley centers as close as possible.
Remove the fan belt.

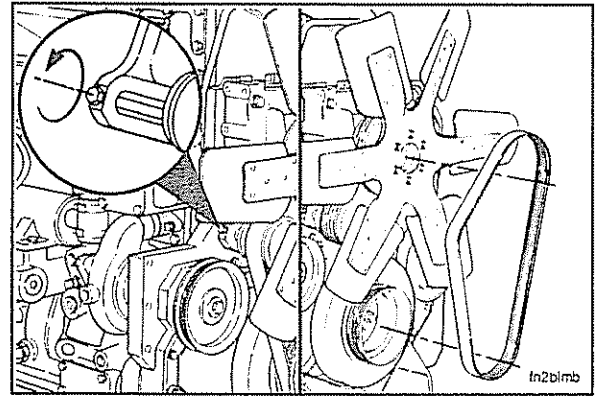

Remove the roll pin and washer from the idler pulley adjusting screw.
Remove the locknut and washer from the back of the idler pulley shaft.
Remove the adjusting screw.
Remove the fan idler pulley from the fan hub support bracket.

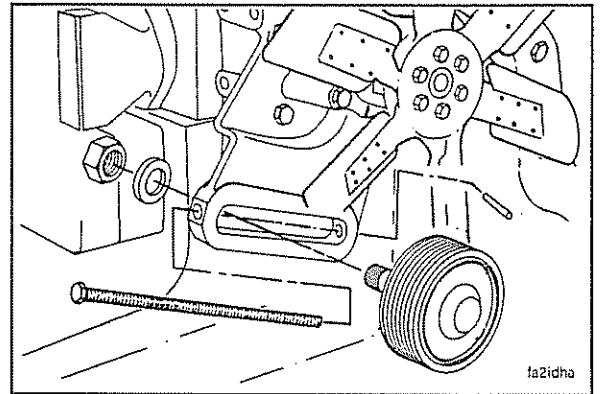

Install

NOTE: Do not tighten the locknut until the fan drive belt has been installed and adjusted.

Install the idler pulley in the fan hub support bracket.
Install the washer and locknut on the idler pulley shaft.

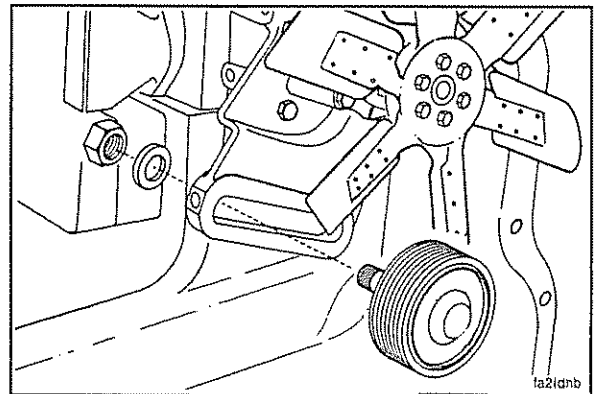

Install the adjusting screw in the idler pulley shaft.
Turn the adjusting screw in far enough to install the washer and roll pin in the shaft at the bottom of the fan hub support bracket.

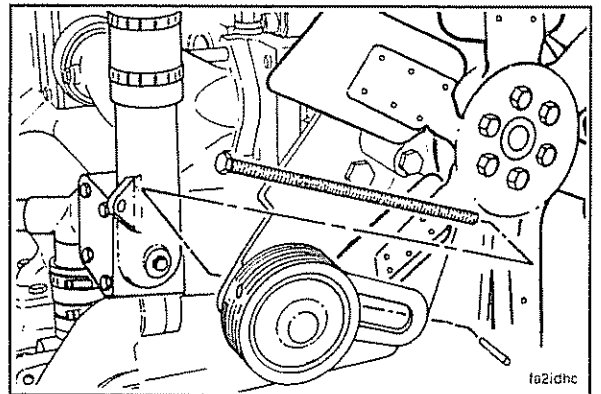

Section A - Adjustment, Repair and Replacement

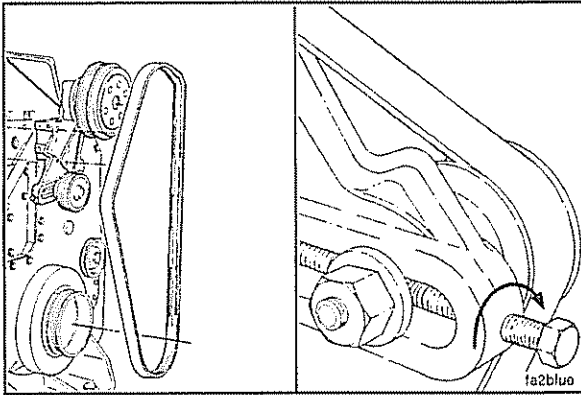

Install and adjust the fan drive belt.

Tighten the idler pulley shaft locknut.

Torque Value: 190 N•m [140 ft-lb]



Check the belt tension again after the locknet is tightened.

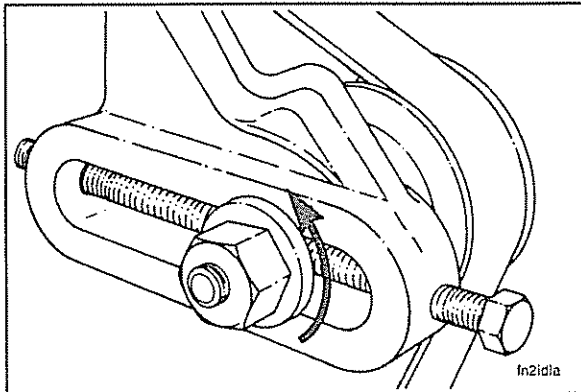

Fan Hub, Belt Driven

Remove

Loosen the fan idler pulley shaft locknut.

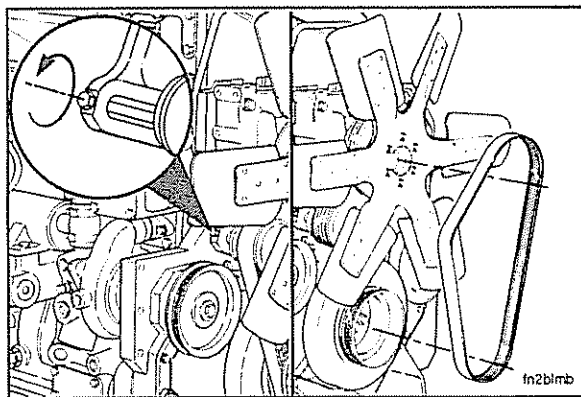

Loosen the adjusting mechanism and move the fan idler pulley and fan pulley centers as close as possible.

Remove the fan belt.

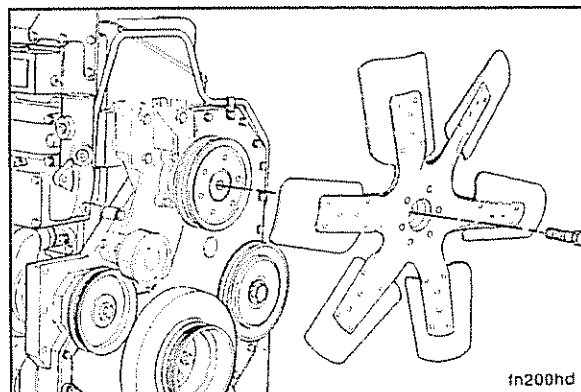

Remove the fan and clutch assembly.



M11
Section A - Adjustment, Repair and Replacement

Remove the fan drive pulley.
Remove the four capscrews and the fan hub.

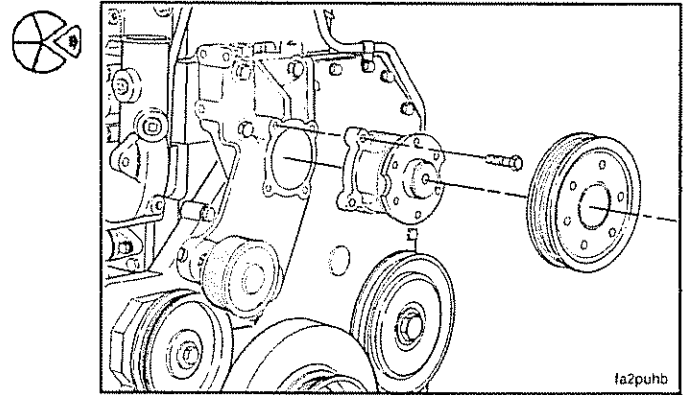

Install
Install the new fan hub and four capscrews.
Torque Value: 47 N•m [35 ft-lb]

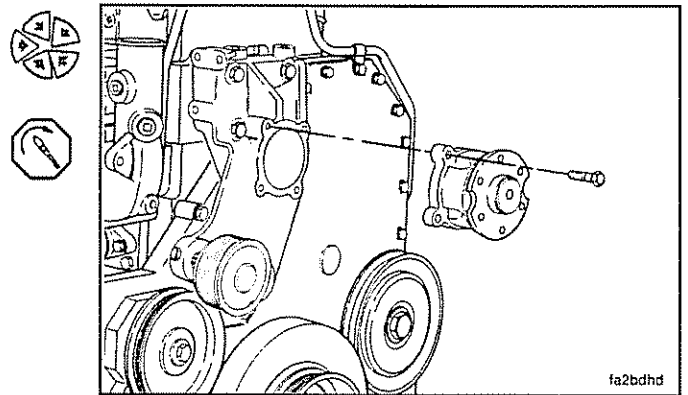

Install the fan drive pulley.
Install the fan and clutch assembly.
Install and tighten the mounting capscrews.
Torque Value: 68 N•m [50 ft-lb]
Install, adjust and tighten the fan drive belt. Refer to Drive Belt Tension in Section V for the correct belt tension.

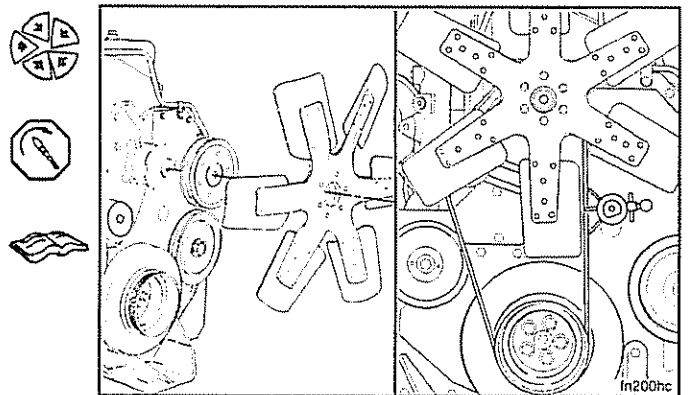

Tighten the fan idler pulley shaft locknut.
Torque Value: 190 N•m [140 ft-lb]
Check the belt tension again after the locknut is tightened.

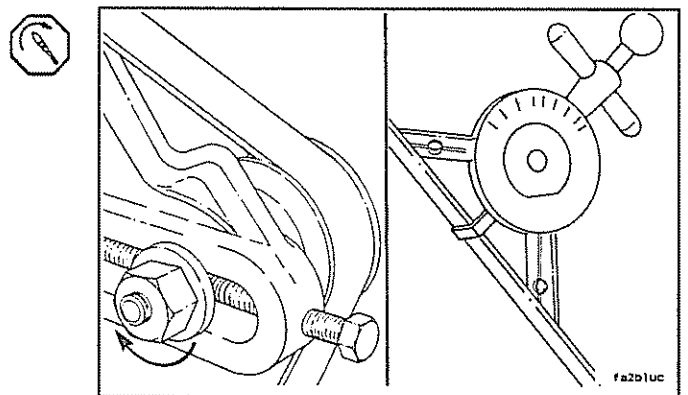

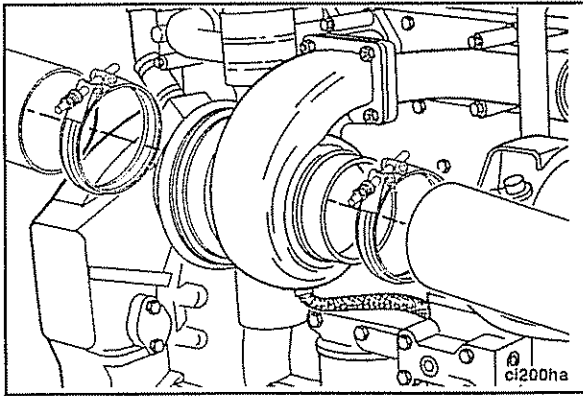

Turbocharger

Remove

Remove the intake and exhaust pipes from the turbocharger.

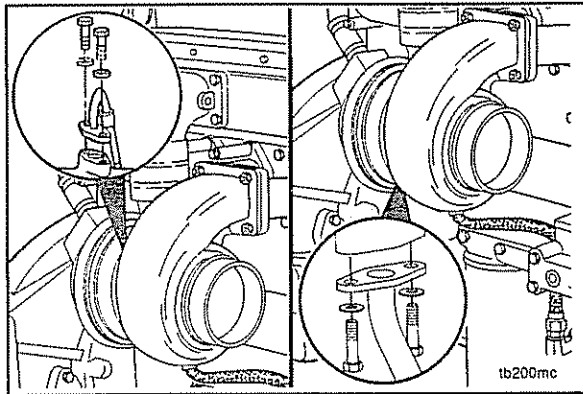

Remove the oil supply line from the turbocharger.

Remove the oil drain line from the turbocharger.

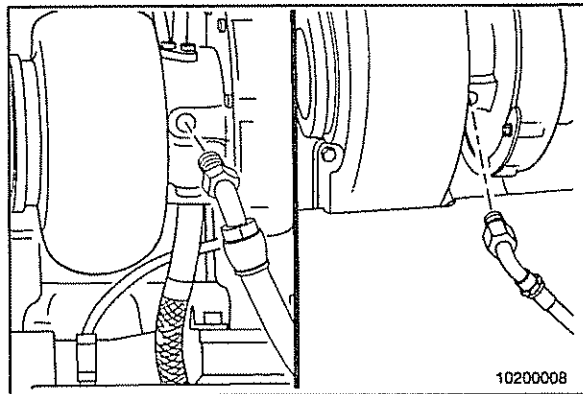

NOTE: Some applications use water-cooled turbochargers.

If a water-cooled turbocharger is used, drain the cooling system and remove the water supply and return lines from the turbocharger.

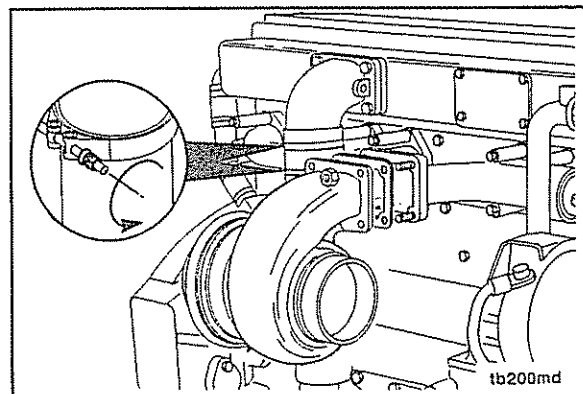

Loosen the hose clamps on the aftercooler air inlet connection.

Remove the four turbocharger mounting nuts.

Remove the turbocharger and gasket.

Install

Apply a film of high temperature anti-seize compound to the turbocharger mounting studs in the exhaust manifold and the turbocharger.

Use a new gasket when installing the turbocharger.

Install the aftercooler air inlet hose evenly over the turbocharger outlet and the aftercooler inlet.

Install and tighten the four mounting nuts.

Torque Value: 61 N•m [45 ft-lb]

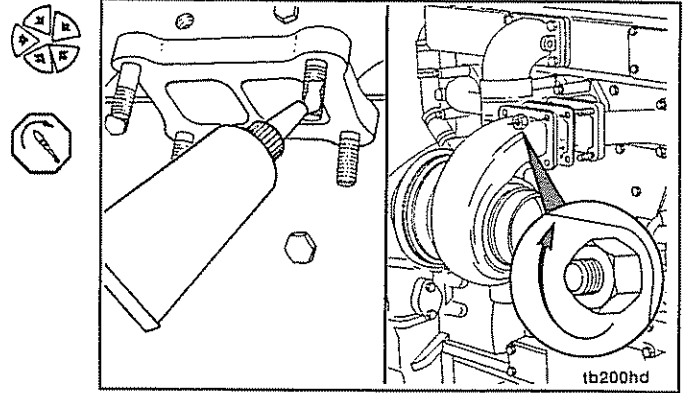

Tighten the hose clamps.

Torque Value: 8 N•m [75 in-lb]

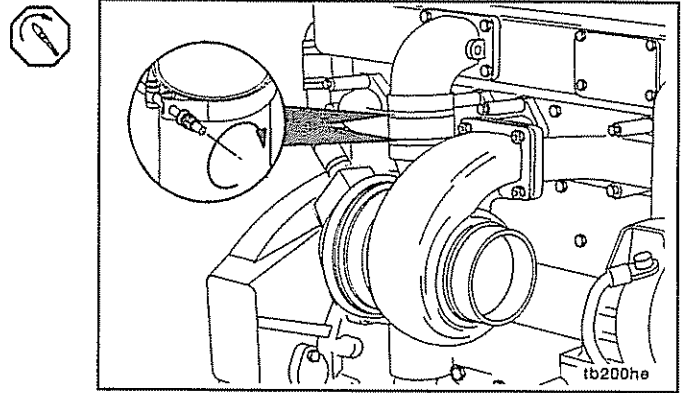

Install a new gasket on the turbocharger oil drain line connection and install the drain line to the bottom of the turbocharger. Tighten the turbocharger the two capscrews.

Torque Value: 27 N•m [20 ft-lb]

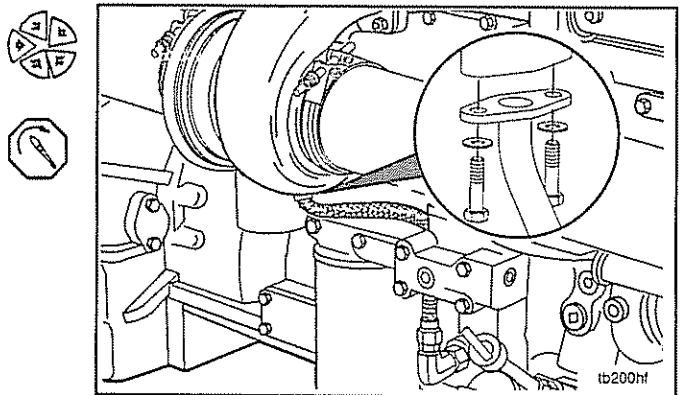

Pour 50 to 60 cc [2.0 to 3.0 ounces] of clean engine oil in the turbocharger oil supply line fitting.

Install a new gasket on the turbocharger oil supply line and install the supply line to the top of the turbocharger. Tighten the two capscrews.

Torque Value: 20 N•m [15 ft-lb]

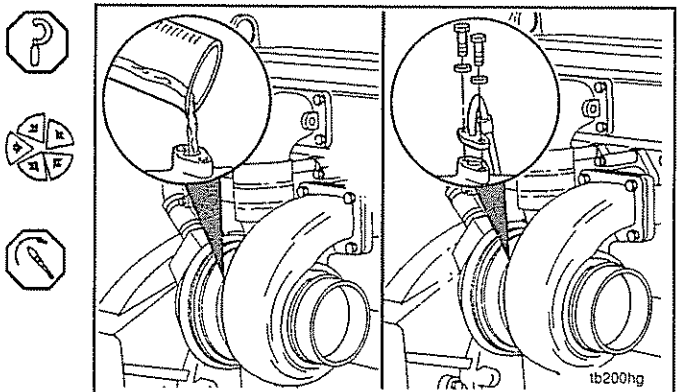

Section A - Adjustment, Repair and Replacement

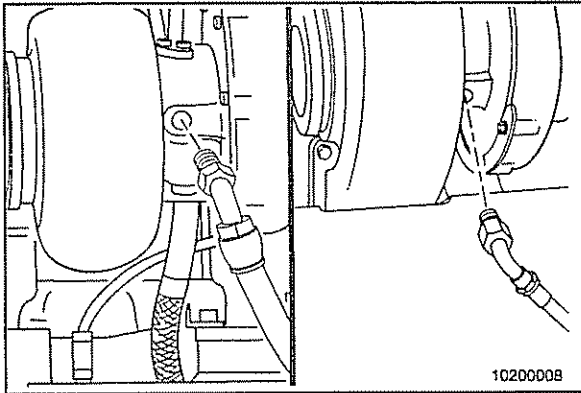

NOTE: Some applications use water-cooled turbochargers. Install the water supply and return lines, if applicable, to the turbocharger and tighten.



Torque Value: 35 N•m [25 ft-lb]

Fill the cooling system. Refer to Section 7.

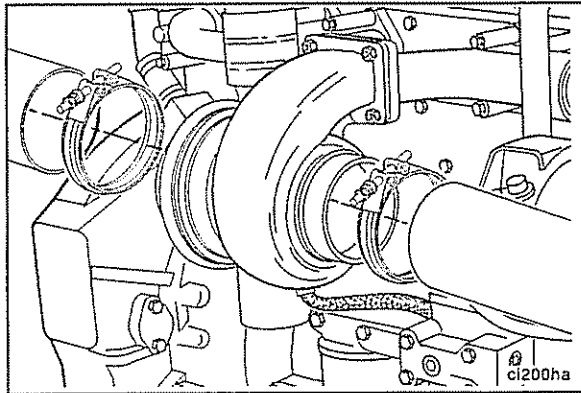

Install the intake pipe and tighten the clamp.
Install the exhaust pipe and tighten the clamp.



Torque Value: 8 N•m [72 in-lb]

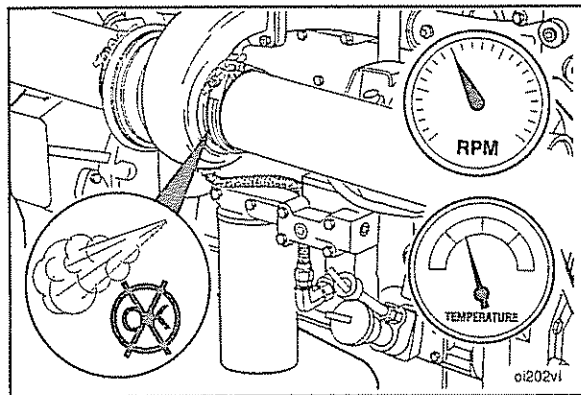

Operate the engine and check for air leaks.

Air Starting Motor

The air starting motor system (tanks, line sizes, and valves) is designed and installed by the original equipment manufacturers and starting motor suppliers. Refer any questions about the air starting systems to the manufacturer.

Air Starting Motor Maintenance

- Do **not** operate the air starting motor with air pressure lower than 480 kPa [70 psi].
- Maintain the air compressor according to the recommendations outlined in the manual.
- For maximum efficiency, the hoses, tubes, and lines **must not** leak.
- Refer to the original equipment manufacturer's and starting motor manufacturer's manuals for specific information regarding the starting motors, valves, and systems.

Engine Storage - Long Term

If the engine will be out of service longer than 6 months, take special precautions to prevent rust. Contact the nearest Cummins Authorized Repair Location, or refer to the Engine Shop Manual, Bulletin No. 3666075, for information concerning engine storage procedures.



Section D - System Diagrams

Section Contents

	Page
Flow Diagram, Air Intake System	D-5
Flow Diagram	D-5
Flow Diagram, Compressed Air System	D-7
Flow Diagram	D-7
Flow Diagram, Cooling System	D-4
Flow Diagram	D-4
Flow Diagram, Exhaust System	D-6
Flow Diagram	D-6
Flow Diagram, Fuel System	D-2
Flow Diagram	D-2
Flow Diagram, Lubricating Oil System	D-3
Flow Diagram	D-3
System Diagrams - General Information	D-1



THIS PAGE LEFT INTENTIONALLY BLANK.

System Diagrams - General Information

The following drawings show the flow through the engine systems. Although parts can change between different applications and installations, the flow remains the same. The systems shown are:

- Fuel System
- Lubricating Oil System
- Coolant System
- Intake Air System
- Exhaust System
- Compressed Air System

Knowledge of the engine systems can help you in troubleshooting, service, and general maintenance of your engine.



Flow Diagram, Fuel System

Flow Diagram

Fuel System - STC

1. Fuel Inlet Supply
2. Fuel Filter
3. Fuel Pump
4. Fuel to Injectors
5. Injector
6. Fuel Drain Return
7. Gear Pump Cooling Return

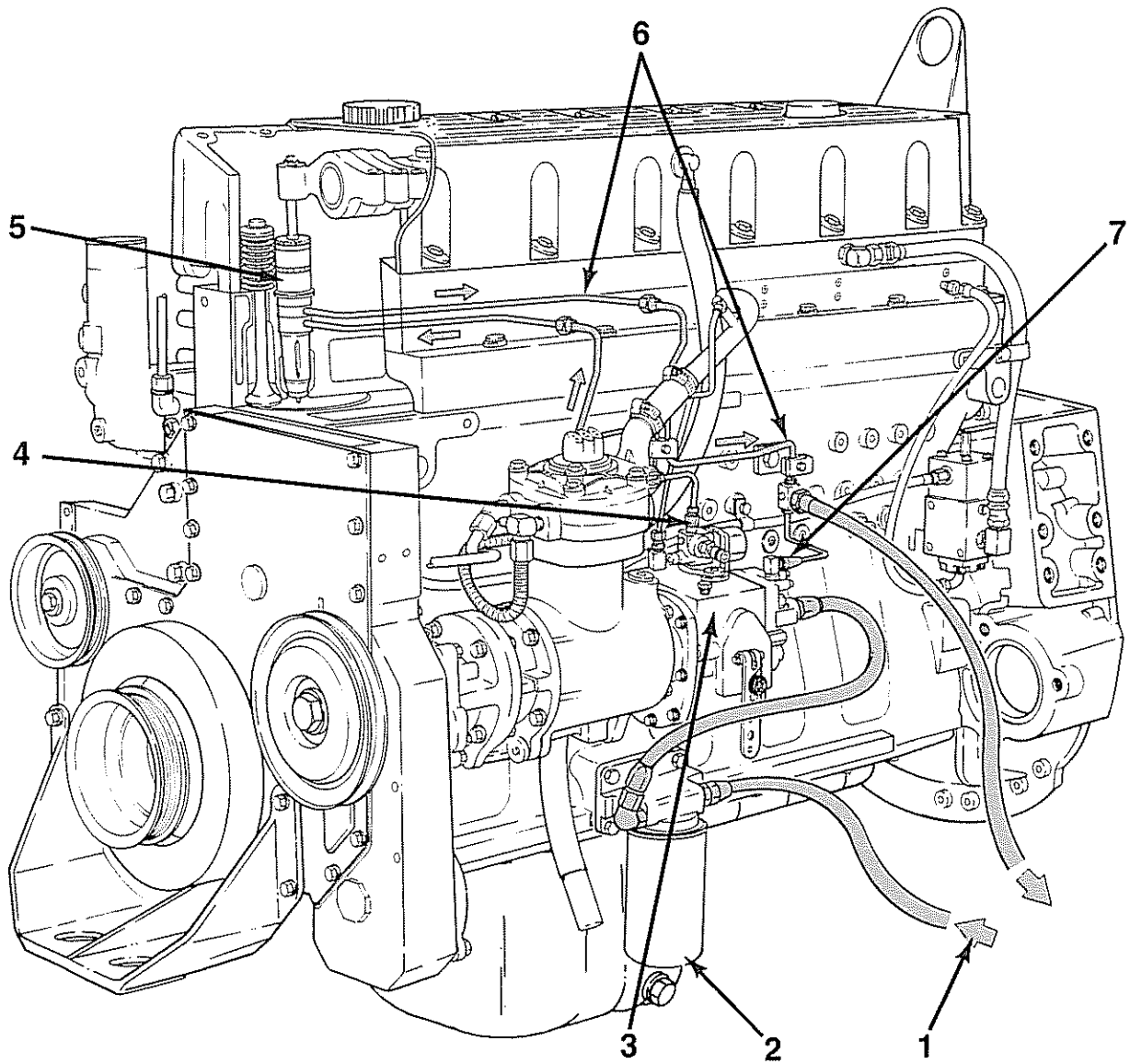

Flow Diagram, Lubricating Oil System

Flow Diagram

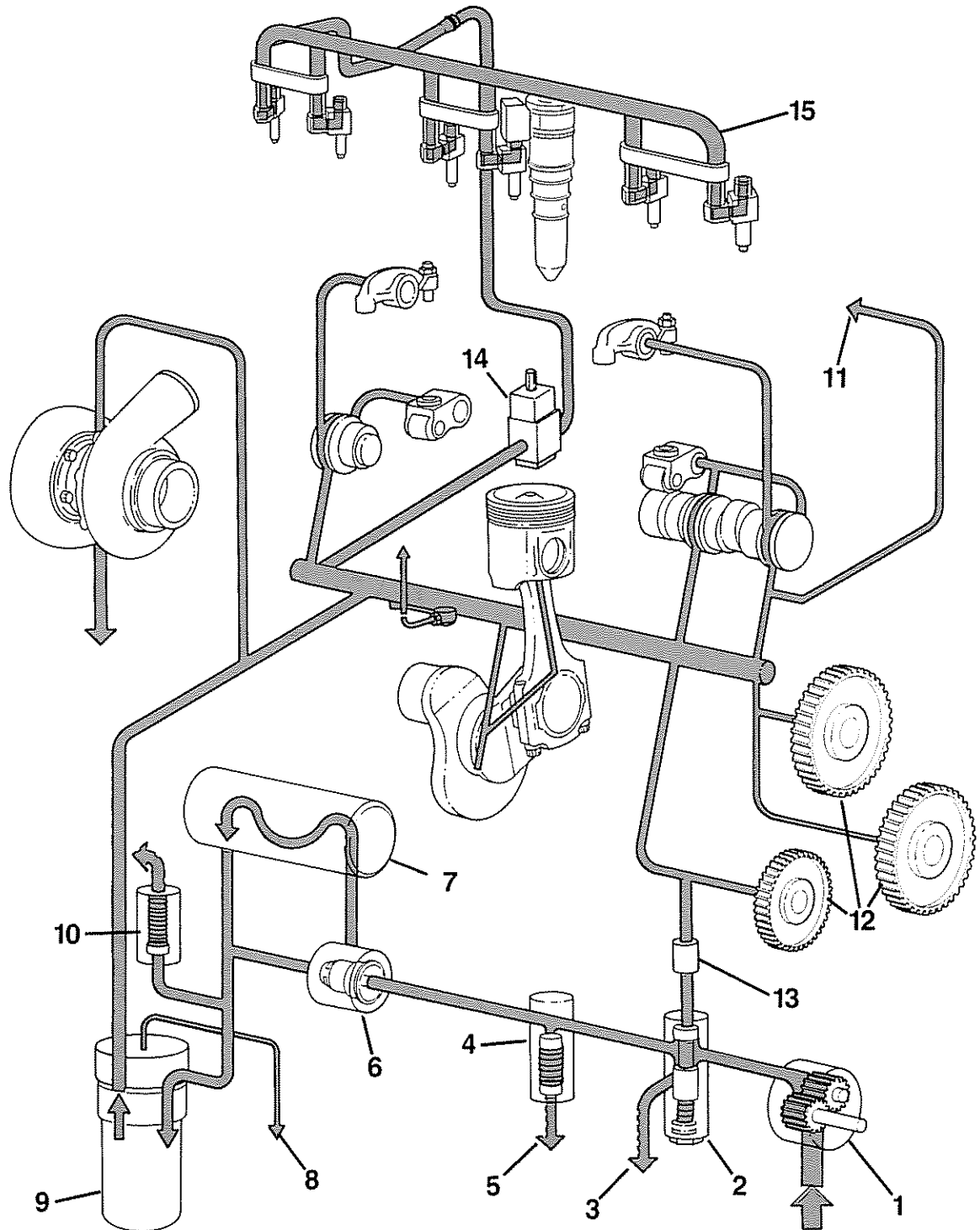

- | | |
|--------------------------------|------------------------------------|
| 1. Oil Pump | 9. Combination Oil Filter |
| 2. Pressure Regulator Valve | 10. Filter By-pass Valve |
| 3. Oil Return to Pan | 11. Accessory Drive/Air Compressor |
| 4. High Pressure Relief Valve | 12. Idler Gears |
| 5. Oil Return to Pan | 13. Viscosity Sensor |
| 6. Oil Thermostat | 14. STC Control Valve |
| 7. Oil Cooler | 15. STC Oil Manifold |
| 8. By-pass Filtered Oil Return | |

Flow Diagram, Cooling System

Flow Diagram

Coolant System

1. Water Pump Coolant Inlet
2. Coolant to Lower Manifold Cavity
3. Coolant to Cylinder Liner Block Cavity
4. Coolant to Cylinder Head
5. Coolant to Upper Manifold Cavity
6. Lower Manifold Coolant to Oil Cooler
7. Oil Cooler to Upper Manifold Cavity

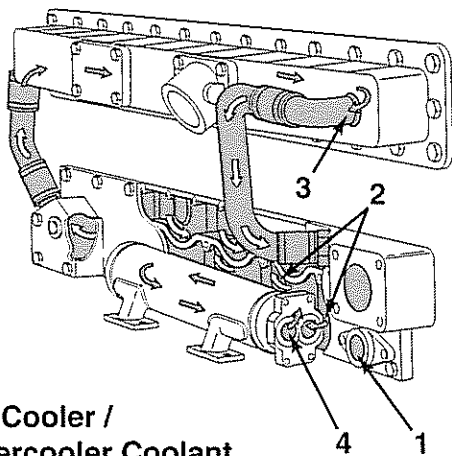
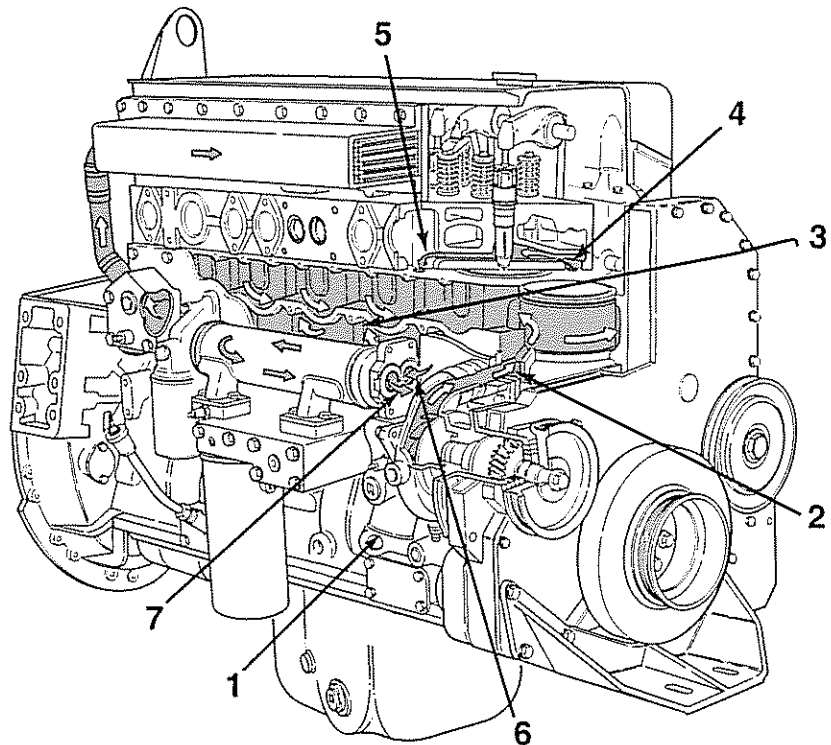

Oil Cooler / Aftercooler Coolant

1. Coolant Entry to Lower Manifold Cavity
2. Lower Manifold Coolant to Oil Cooler / Aftercooler
3. Aftercooler Coolant Outlet to Upper Manifold Cavity
4. Oil Cooler Water Outlet to Upper Manifold

Orifice Directs Coolant Flow To The Torque Converter Cooler When Thermostat Is Closed

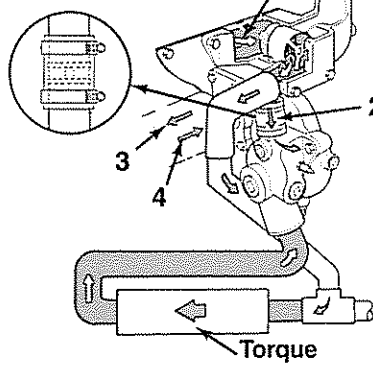

Closed

1. Upper Manifold Cavity (Coolant to Thermostat)
2. Coolant Bypass (Return to Water Pump)
3. Lower Manifold Cavity to Cooler
4. Cooler to Upper Manifold Cavity (Before Thermostat)

Thermostat

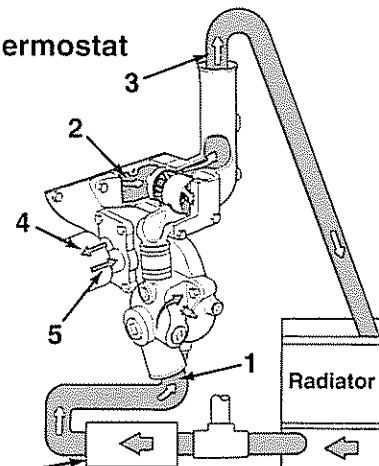

Open

1. Water Pump Coolant Inlet
2. Upper Manifold Cavity (Coolant to Thermostat)
3. Coolant Outlet
4. Lower Manifold Cavity to Cooler
5. Cooler to Upper Manifold Cavity (Before Thermostat)

Flow Diagram, Air Intake System

Flow Diagram

Intake System

1. Filtered Intake Air to Turbocharger
2. Turbocharger Air to Aftercooler
3. Aftercooler
4. Intake Manifold
5. Intake Valve Ports

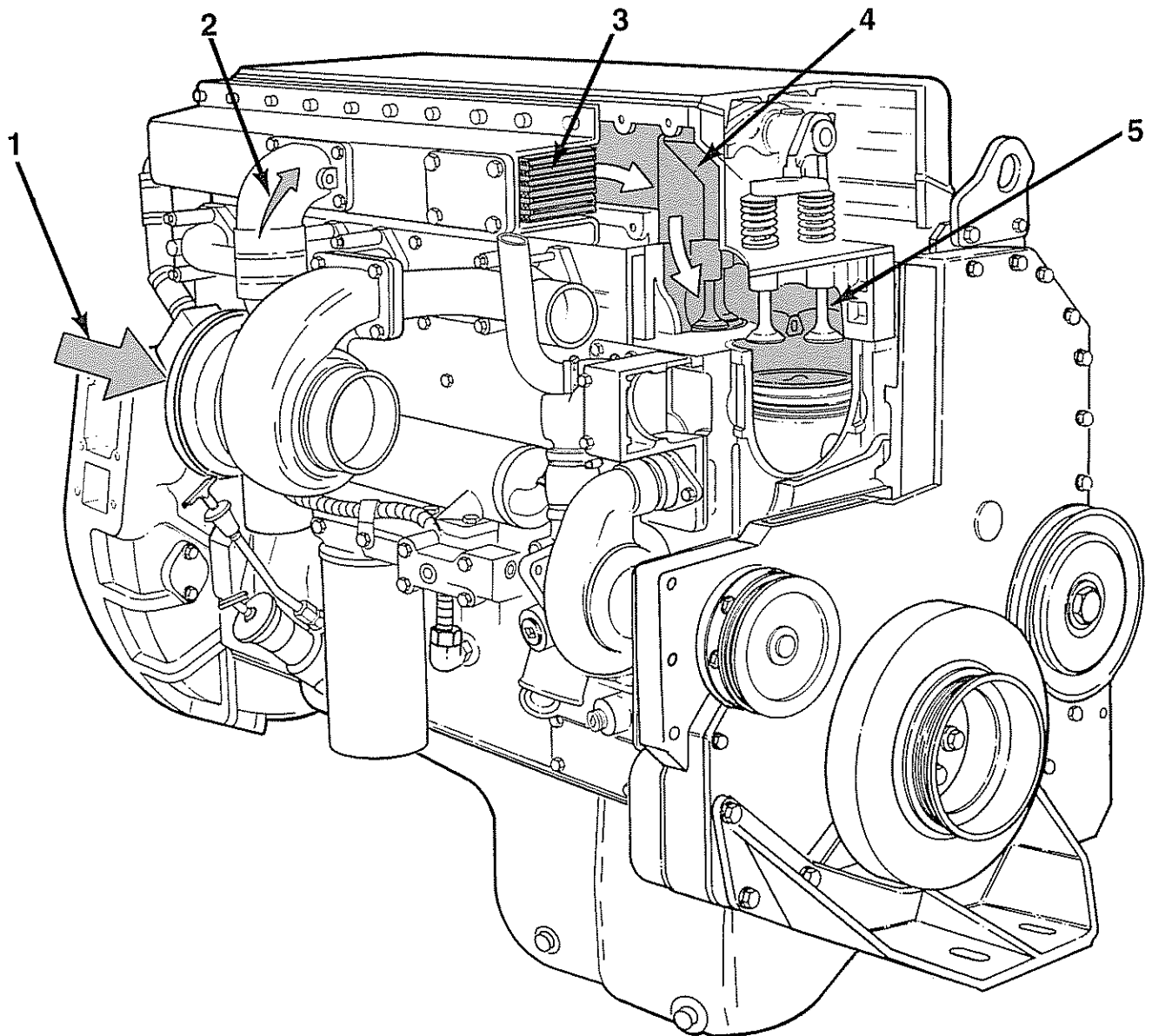

Flow Diagram, Exhaust System

Flow Diagram

Exhaust System

1. Exhaust Valve Ports
2. Exhaust Manifold
3. Turbocharged Exhaust Outlet

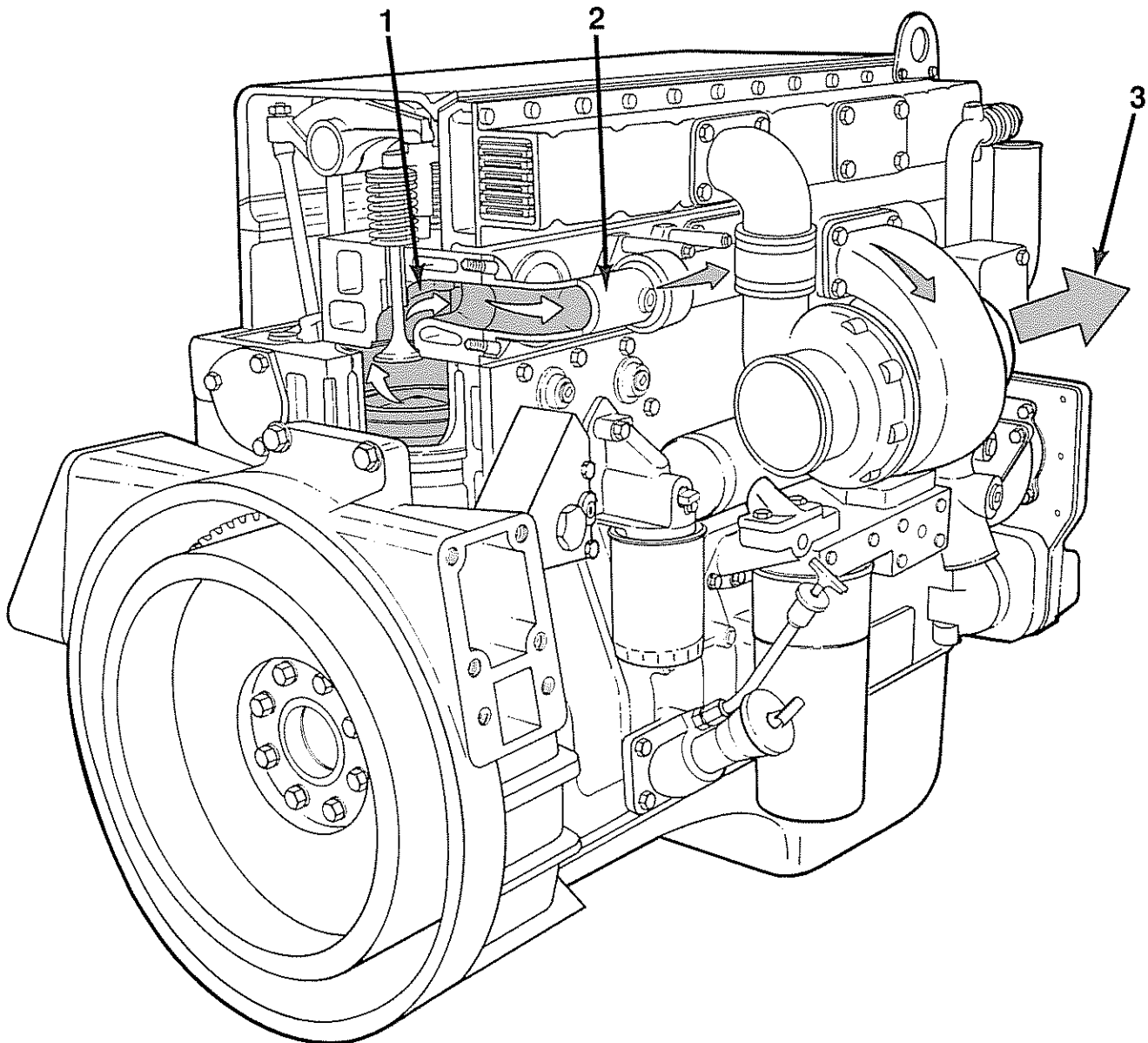

Flow Diagram, Compressed Air System

Flow Diagram

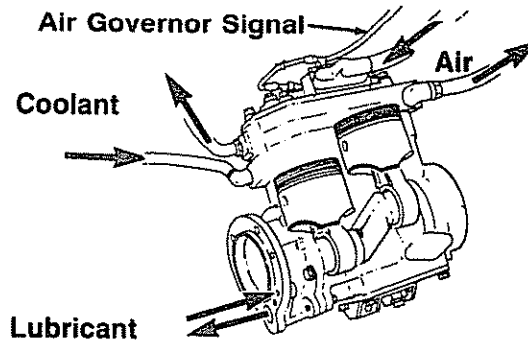
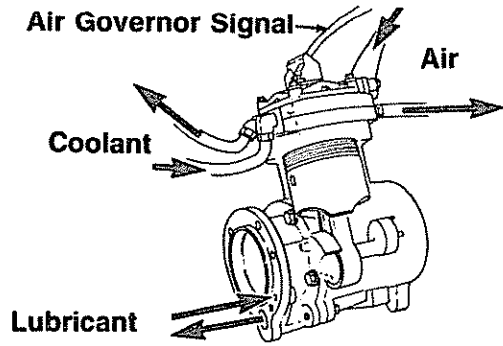

cp800pb



Section L - Service Literature

Section Contents

	Page
Additional Service Literature.....	L-1
Literature Order Form.....	L-3
Service Literature Ordering Location.....	L-2



THIS PAGE LEFT INTENTIONALLY BLANK.

Additional Service Literature

The following publications can be purchased by filling in and mailing the Literature Order Form:

Bulletin No.	Title of Publication
3666139	Troubleshooting and Repair Manual, M11 Series Engines
3666075	Shop Manual, M11 Series Engines
3666076	Specifications Manual, M11 Series Engines
3810388	L10 Overhead Reuse Guidelines
3810340	Cummins Engine Oil Recommendations
3379001	Fuel for Cummins Engines (QP-20)
3810344	PT (Type D) Top Stop Injector Shop Manual
3379084	Fuel Pump (PT Type G) Rebuild and Calibrate
3810490	Shop and Installation Manual - Rear Engine Power Takeoff



Service Literature Ordering Location

Region	Ordering Location
United States and Canada	Cummins Distributors or Contact 1-800-DIESELS (1-800-343-7357)
U.K., Europe, Mid-East, Africa, and Eastern European Countries	Cummins Engine Co., Ltd. Royal Oak Way South Daventry Northants, NN11 5NU, England
South and Central America (excluding Brazil and Mexico)	Cummins Americas, Inc. 16085 N.W. 52nd Avenue Hialeah, FL 33104
Brazil and Mexico	Cummins Engine Co., Inc. International Parts Order Dept., MC 40931 Box 3005 Columbus, IN 47202-3005
Far East (excluding Australia and New Zealand)	Cummins Diesel Sales Corp. Literature Center 8 Tanjong Penjuru Jurong Industrial Estate Singapore
Australia and New Zealand	Cummins Diesel Australia Maroondah Highway, P.O.B. 139 Ringwood 3134 Victoria, Australia

Obtain current price information from your local Cummins Distributor.

Literature Order Form

Use this form for prompt handling of your literature order.

Item	Bulletin Number	Title of Publication	Quantity	U.S. Price Each	Amount
1				\$	\$
2					
3					
4					
5					
6					
Order Total					\$

Contact your Cummins distributor for prices and availability.

For problems with literature orders (for U.S.A. and Canada), contact 1-800-DIESELS (1-800-343-7357). All other locations contact your local Distributor.

Prices subject to change without notice.

Please cut on dotted line

Literature Order Form

Use this form for prompt handling of your literature order.

Item	Bulletin Number	Title of Publication	Quantity	U.S. Price Each	Amount
1				\$	\$
2					
3					
4					
5					
6					
Order Total					\$

Contact your Cummins distributor for prices and availability.

For problems with literature orders (for U.S.A. and Canada), contact 1-800-DIESELS (1-800-343-7357). All other locations contact your local Distributor.

Prices subject to change without notice.

Mail the Literature Order Form along with your ship-to address to your nearest Cummins distributor.

FROM:		
Name:		
Street Address:		
City:	State/Province:	Zip/Postal Code:
Country:		

SHIP TO: (Name and address where literature is to be shipped)		
Name:		
Street Address:		
City:	State/Province:	Zip/Postal Code:
Country:		

Please cut on dotted line

Mail the Literature Order Form along with your ship-to address to your nearest Cummins distributor.

FROM:		
Name:		
Street Address:		
City:	State/Province:	Zip/Postal Code:
Country:		

SHIP TO: (Name and address where literature is to be shipped)		
Name:		
Street Address:		
City:	State/Province:	Zip/Postal Code:
Country:		

Section M - Component Manufacturers

Section Contents

	Page
Component Manufacturers' Addresses	M-1
Air Compressors.....	M-1
Air Cylinders	M-1
Air Heaters.....	M-1
Air Starting Motors	M-1
Alternators.....	M-1
Auxiliary Brakes	M-1
Belts.....	M-1
Catalytic Convertors	M-1
Clutches.....	M-1
Coolant Heaters	M-2
Coolant Level Switches	M-1
Drive Plates.....	M-2
Electric Starting Motors	M-2
Electronic Switches	M-2
Engine Protection Controls	M-2
Fan Clutches.....	M-2
Fans.....	M-2
Fault Lamps	M-2
Filters.....	M-2
Flexplates.....	M-2
Fuel Coolers.....	M-2
Fuel Warmers.....	M-2
Gauges	M-2
Governors	M-3
Heat Sleeves.....	M-3
Hydraulic and Power Steering Pumps.....	M-3
In-Line Connectors	M-3
Oil Heaters.....	M-3
Prelubrication Systems.....	M-3
Radiators.....	M-3
Throttle Assemblies.....	M-3
Torque Converters	M-3



THIS PAGE LEFT INTENTIONALLY BLANK.

Component Manufacturers' Addresses

NOTE: The following list contains addresses and telephone numbers of suppliers of accessories used on Cummins engines. Suppliers can be contacted directly for any specifications **not** covered in this manual.

Air Compressors

Bendix Heavy Vehicles Systems
Div. of Allied Automotive
901 Cleveland Street
Elyria, OH 44036
Telephone: (216) 329-9000

Holset Engineering Co., Inc.
1320 Kemper Meadow Drive
Suite 500
Cincinnati, OH 45240
Telephone: (513) 825-9600

Midland-Grau
Heavy Duty Systems
Heavy Duty Group Headquarters
10930 N. Pamona Avenue
Kansas City, MO 64153
Telephone: (816) 891-2470

Air Cylinders

Bendix Ltd.
Douglas Road
Kingswood
Bristol
England
Telephone: 0117-671881

Catching Engineering
1733 North 25th Avenue
Melrose Park, IL 60160
Telephone: (708) 344-2334

TEC - Hackett Inc.
8909 Rawles Avenue
Indianapolis, IN 46219
Telephone: (317) 895-3670

Air Heaters

Fleetguard, Inc.
1200 Fleetguard Road
Cookeville, TN 38502
Telephone: (615) 526-9551

Kim Hotstart Co.
P.O. Box 11245
Spokane, WA 99211-0245
Telephone: (509) 534-6171

Air Starting Motors

Ingersoll Rand
Chorley New Road
Horwich
Bolton
Lancashire
England
BL6 6JN
Telephone: 01204-65544

Ingersoll-Rand Engine
Starting Systems
888 Industrial Drive
Elmhurst, IL 60126
Telephone: (708) 530-3875

StartMaster
Air Starting Systems
A Division of Sycon Corporation
9595 Cheney Avenue
P. O. Box 491
Marion, OH 43302
Telephone: (614) 382-5771

Alternators

Robert Bosch Ltd.
P.O. Box 98
Broadwater Park
North Orbital Road
Denham
Uxbridge
Middlesex UD9 5HG
England
Telephone: 01895-833633

Butec Electrics
Cleveland Road
Leyland
PR5 1XB
England
Telephone: 01744-21663

C.A.V. Electrical Equipment
P.O. Box 36
Warple Way
London
W3 7SS
England
Telephone: 01-743-3111

A.C. Delco Components Group
Civic Offices
Central Milton Keynes
MK9 3EL
England
Telephone: 01908-66001

C. E. Niehoff & Co.
2021 Lee Street
Evanston, IL 60202
Telephone: (708) 866-6030

Delco-Remy America
2401 Columbus Avenue
P.O. Box 2439
Anderson, IN 46018
Telephone: (317) 646-3528

Leece-Neville Corp.
400 Main Street
Arcade, NY 14009
Telephone: (716) 492-1700

Auxiliary Brakes

The Jacobs Manufacturing Company
Vehicle Equipment Division
22 East Dudley Town Road
Bloomfield, CT 06002
Telephone: (203) 243-1441

Belts

Dayco Rubber U.K.
Sheffield Street
Stockport
Cheshire
SK4 1RV
England
Telephone: 061-432-5163

T.B.A. Belting Ltd.
P.O. Box 77
Wigan
Lancashire
WN2 4XQ
England
Telephone: 01942-59221

Dayco Mfg.
Belt Technical Center
1955 Enterprize
Rochester Hills, MI 48309
Telephone: (810) 853-8300

Gates Rubber Company
900 S. Broadway
Denver, CO 80217

Goodyear Tire and
Rubber Company
Industrial Products Div.
2601 Fortune Circle East
Indianapolis, IN 46241
Telephone: (317) 898-4170

Catalytic Convertors

Donaldson Company, Inc.
1400 West 94th Street
P.O. Box 1299
Minneapolis, MN 55440
Telephone: (612) 887-3835

Nelson Division
Exhaust and Filtration Systems
1801 U.S. Highway 51 P.O. Box 428
Stoughton, WI 53589
Telephone: (608) 873-4200

Walker Manufacturing
3901 Willis Road
P.O. Box 157
Grass Lake, MI 49240
Telephone: (517) 522-5500

Coolant Level Switches

Robertshaw Controls Company
P.O. Box 400
Knoxville, TN 37901
Telephone: (216) 885-1773

Clutches

Twin Disc International S.A.
Chaussee de Namur
Nivelles
Belguim
Telephone: 067-224941

Twin Disc Incorporated
1328 Racine Street
Racine, WI 53403
Telephone: (414) 634-1981

Coolant Heaters

Fleetguard, Inc.
1200 Fleetguard Road
Cookeville, TN 38502
Telephone: (615) 526-9551

Drive Plates

Detroit Diesel Allison
Division of General Motors
Corporation
P.O. Box 894
Indianapolis, IN 46206-0894
Telephone: (317) 242-5000

Electric Starting Motors

Butec Electrics
Cleveland Road
Leyland
PR5 1XB
England
Telephone: 01744-21663

C.A.V. Electrical Equipment
P.O. Box 36
Warple Way
London
W3 7SS
England
Telephone: 01-743-3111

A.C. Delco Components Group
Civic Offices
Central Milton Keynes
MK9 3EL
England
Telephone: 0908-66001

Delco-Remy America
2401 Columbus Avenue
P.O. Box 2439
Anderson, IN 46018
Telephone: (317) 646-3528

Leece-Neville Corp.
400 Main Street
Arcade, NY 14009
Telephone: (716) 492-1700

Nippondenso Inc.
2477 Denso Drive
P.O. Box 5133
Southfield, MI 48086
Telephone: (313) 350-7500

Electronic Switches

Cutler-Hammer Products
Eaton Corporation
4201 N. 27th Street
Milwaukee, WI 53216
Telephone: (414) 449-6600

Engine Protection Controls

Flight Systems Headquarters
Hempt Road
P.O. Box 25
Mechanicsburg, PA 17055
Telephone: (717) 697-0333

The Nason Company
2810 Blue Ridge Blvd.
West Union, SC 29696
Telephone: (803) 638-9521

Teddington Industrial
Equipment
Windmill Road
Sunburn on Thames
Middlesex
TW16 7HF
England
Telephone: 09327-85500

Fan Clutches

Holset Engineering Co. Ltd.
P.O. Box A9
Turnbridge
Huddersfield, West Yorkshire
England HD6 7RD
Telephone: 01484-22244

Horton Industries, Inc.
P.O. Box 9455
Minneapolis, MN 55440
Telephone: (612) 378-6410

Rockford Clutch Company
1200 Windsor Road
P.O. Box 2908
Rockford, IL 61132-2908
Telephone: (815) 633-7460

Fans

Truflo Ltd.
Westwood Road
Birmingham
B6 7JF
England
Telephone: 021-557-4101

Hayes-Albion Corporation
Jackson Manufacturing Plant
1999 Wildwood Avenue
Jackson, MI 49202
Telephone: (517) 782-9421

Engineered Cooling Systems, Inc.
201 W. Carmel Drive
Carmel, IN 46032
Telephone: (317) 846-3438

Brookside Corporation
P.O. Box 30
McCordsville, IN 46055
Telephone: (317) 335-2014

TCF Aerovent Company
9100 Purdue Rd., Suite 101
Indianapolis, IN 46268-1190
Telephone: (317) 872-0030

Kysor-Cadillac
1100 Wright Street
Cadillac, MI 49601
Telephone: (616) 775-4681

Schwitzer
6040 West 62nd Street
P.O. Box 80-B
Indianapolis, IN 46206
Telephone: (317) 328-3010

Fault Lamps

Cutler-Hammer Products
Eaton Corporation
4201 N. 27th Street
Milwaukee, WI 53216
Telephone: (414) 449-6600

Filters

Fleetguard International Corp.
Cavalry Hill Industrial Park
Weedon
Northampton NN7 4TD
England
Telephone: 01327-41313

Fleetguard, Inc.
1200 Fleetguard Road
Cookeville, TN 38502
Telephone: (615) 526-9551

Flexplates

Corrugated Packing and
Sheet Metal
Hamsterley
Newcastle Upon Tyne
England
Telephone: 01207-560-505

Allison Transmission
Division of General Motors
Corporation
P.O. Box 894
Indianapolis, IN 46206-0894
Telephone: (317) 242-5000

Midwest Mfg. Co.
29500 Southfield Road, Suite 122
Southfield, MI 48076
Telephone: (313) 642-5355

Wohlert Corporation
708 East Grand River Avenue
P.O. Box 20217
Lansing, MI 48901
Telephone: (517) 485-3750

Fuel Coolers

Hayden, Inc.
1531 Pomona Road
P.O. Box 848
Corona, CA 91718-0848
Telephone: (909) 736-2665

Fuel Warmers

Fleetguard, Inc.
1200 Fleetguard Road
Cookeville, TN 38502
Telephone: (615) 526-9551

Gauges

A.I.S.
Dyffon Industrial Estate
Ystrad Mynach
Hengoed
Mid Glamorgan
CF8 7XD
England
Telephone: 01443-812791

Grasslin U.K. Ltd.
Vale Rise
Tonbridge
Kent
TN9 1TB
England
Telephone: 01732-359888

Icknield Instruments Ltd.
Jubilee Road
Letchworth
Herts
England
Telephone: 04626-5551

Superb Tool and Gauge Co.
21 Princip Street
Birmingham
B4 61E
England
Telephone: 021-359-4876

Kabi Electrical and Plastics
Cranborne Road
Potters Bar
Herts
EN6 3JP
England
Telephone: 01707-53444

Datcon Instruments
P.O. Box 128
East Petersburg, PA 17520
Telephone: (717) 569-5713

Rochester Gauges, Inc.
11616 Harry Hines Blvd.
P.O. Box 29242
Dallas, TX 75229
Telephone: (214) 241-2161

Governors

Woodward Governors Ltd.
P.O. Box 15
663/664 Ajax Avenue
Slough
Bucks
SL1 4DD
England
Telephone: 01753-26835

Woodward Governor Co.
P.O. Box 1519
Fort Collins, CO 80522
Telephone: (303) 482-5811
(800) 523-2831

Barber Colman Co.
1354 Clifford Avenue
Loves Park, IL 61132
Telephone: (815) 637-3000

United Technologies
Diesel Systems
1000 Jorie Blvd.
Suite 111
Oak Brook, IL 69521
Telephone: (312) 325-2020

Heat Sleeves

Bentley Harris Manufacturing Co.
100 Bentley Harris Way
Gordonville, TN 38563
Telephone: (313) 348-5779

Hydraulic and Power Steering Pumps

Hobourn Automotive
Temple Farm Works
Priory Road
Strood
Rochester
Kent, England
ME2 2BD
Telephone: 01634-71773

Honeywell Control Systems Ltd.
Honeywell House
Charles Square
Bracknell
Berks RG12 1EB
Telephone: 01344-4245

Sundstrand Hydratec Ltd.
Cheney Manor Trading Estate
Swindon
Wiltshire
SN2 2PZ
England
Telephone: 01793-30101

Sperry Vickers
P.O. Box 302
Troy, MI 48084
Telephone: (313) 280-3000

Z.F.
P.O. Box 1340
Grafvonsoden Strasse
5-9 D7070
Schwaebisch Gmuend
Germany
Telephone: 7070-7171-31510

In-Line Connectors

Pioneer-Standard Electronics, Inc.
5440 Neiman Parkway
Solon, OH 44139
Telephone: (216) 349-1300

Deutsch
Industrial Products Division
37140 Industrial Avenue
Hemet, CA 92343
Telephone: (714) 929-1200

Oil Heaters

Fleetguard, Inc.
1200 Fleetguard Road
Cookeville, TN 38502
Telephone: (615) 526-9551

Kim Hotstart Co.
P.O. Box 11245
Spokane, WA 99211-0245
Telephone: (509) 534-6171

Prelubrication Systems

RPM Industries, Inc.
Suite 109
55 Hickory Street
Washington, PA 15301
Telephone: (412) 228-5130

Radiators

JB Radiator Specialties, Inc.
P.O. Box 292087
Sacramento, CA 95829-2087
Telephone: (916) 381-4791

The G&O Manufacturing Company
100 Gando Drive
P.O. Box 1204
New Haven, CT 06505-1204
Telephone: (203) 562-5121

Young Radiator Company
2825 Four Mile Road
Racine, WI 53404
Telephone: (910) 271-2397

L and M Radiator, Inc.
1414 East 37th Street
Hibbing, MN 55746
Telephone: (218) 263-8993

Throttle Assemblies

Williams Controls, Inc.
14100 SW 72nd Avenue
Portland, OR 97224
Telephone: (503) 684-8600

Torque Converters

Twin Disc International S.A.
Chaussee de Namur
Nivelles
Belgium
Telephone: 067-224941

Twin Disc Incorporated
1328 Racine Street
Racine, WI 53403-1758
Telephone: (414) 634-1981

Rockford Powertrain, Inc.
Off-Highway Systems
1200 Windsor Road
P.O. Box 2908
Rockford, IL 61132-2908
Telephone: (815) 633-7460

Modine Mfg. Co.
1500 DeKoven Avenue
Racine, WI 53401
Telephone: (414) 636-1640

Section S - Service Assistance

Section Contents

	Page
Service Assistance	S-1
Distributors - International	S-18
Distributors and Branches - Australia	S-13
Distributors and Branches - Canada	S-11
Distributors and Branches - New Zealand	S-14
Distributors and Branches - United States	S-4
Division and Regional Offices	S-3
Emergency and Technical Service	S-1
Problem Solving	S-2
Regional Offices - International	S-15
Routine Service and Parts	S-1



THIS PAGE LEFT INTENTIONALLY BLANK.

Service Assistance

Routine Service and Parts

Personnel at Cummins Authorized Repair Locations can assist you with the correct operation and service of your engine. Cummins has a worldwide service network of more than 5,000 Distributors and Dealers who have been trained to provide sound advice, expert service, and complete parts support. Check the telephone directory yellow pages or refer to the directory in this section for the nearest Cummins Authorized Repair Location.

Emergency and Technical Service

The Cummins Customer Assistance Center provides a 24-hour, toll free telephone number to aid in technical and emergency service when a Cummins Authorized Repair Location can **not** be reached or is unable to resolve an issue with a Cummins product.

If additional assistance is required, call Toll-Free:

1-800-DIESELS
(1-800-343-7357)

- Includes all 50 states, Bermuda, Puerto Rico, Virgin Islands, and the Bahamas.
- Outside of North America contact your Regional Office. Telephone numbers and addresses are listed in the International Directory.

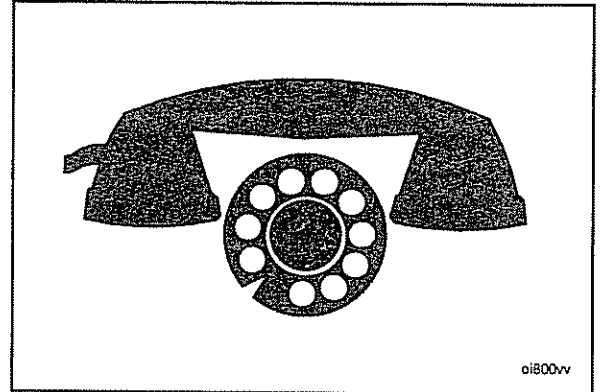

Problem Solving

Normally, any problem that arises with the sale, service, or repair of your engine can be handled by a Cummins Authorized Repair Location in your area. Refer to the telephone directory yellow pages for the one nearest you. If the problem has **not** been handled satisfactorily, follow the steps outlined below:

1. If the disagreement is with a Dealer, talk to the Cummins Distributor with whom he has his service agreement.
2. If the disagreement is with a Distributor, call the nearest Cummins Division or Regional Office; however, most problems are solved below the Division or Regional office level. Telephone numbers and addresses are listed in this section. Before calling, write down the following information:
 - a. Engine model and serial number
 - b. Type and make of equipment
 - c. Total kilometers [miles] or hours of operation
 - d. Warranty start date
 - e. Nature of problem
 - f. Summary of the current problem arranged in the order of occurrence
 - g. Name and location of the Cummins Distributor or Dealer
3. If a problem can **not** be resolved satisfactorily through your Cummins Authorized Repair Location or Division Office, write to:

Customer Relations - 41403, Cummins Engine Company, Inc., Box 3005, Columbus, IN 47202-3005

Division and Regional Offices

NOTE: The following list contains offices in U.S., Canada, Australia, New Zealand, and Puerto Rico.

United States

Northern Division Office

Cummins Engine Company, Inc.
21 Southpark Blvd.
Greenwood, IN 46143
Telephone: (317) 885-4400
FAX: (317) 885-4423

Southern Division Office

Cummins Engine Company, Inc.
425 Franklin Road S.W.
Suite 500
Marietta, GA 30067
Telephone: (404) 423-1108
FAX: (404) 499-8240

Western Division Office

Cummins Engine Company, Inc.
5660 Greenwood Plaza Blvd.
Englewood, CO 80111
Telephone: (303) 773-2866
FAX: (303) 779-1629

Western Regional Office

Cummins Engine Company, Inc.
569 First Street West
Sonoma, CA 95476
Telephone: (707) 935-3842
FAX: N/A

Plains Regional Office

Cummins Engine Company, Inc.
1901 Central Drive
Suite 356
Bedford, TX 76021
Telephone: (817) 267-3172
FAX: N/A

Canada

Canadian Division Office

Cummins Diesel of Canada, Ltd.
700 Dorval Drive
Suite 600
Oakville, Ontario L6K 3V3
Telephone: (905) 842-8070
FAX: (905) 842-8075

Western Canada Regional Office

Cummins Diesel of Canada, Ltd.
18452 - 96th Avenue
Surrey, B.C. V3T 4W2
Telephone: (604) 882-5727
FAX: (604) 882-9110

Eastern Canada Regional Office

Cummins Diesel of Canada Ltd.
7200 Trans Canada Hwy.
Pt. Cuaire, Quebec H9R 1C0
Telephone: (514) 695-2402
FAX: (514) 695-8917

Central Canada Regional Office

Cummins Diesel of Canada Ltd.
4887 - 35th Street SE
Calgary, Alberta T2B 3C6
FAX: (403) 569-9974

Australia Regional Office

Diesel ReCon Australia

2 Caribbean Drive
Scoresby, Victoria 3179
Australia
Telephone: (61) 3-765-3222
FAX: (61) 3-763-0079

NOTE: This office also serves New Zealand.

Cummins Americas Regional Office

Cummins Caribbean

16085 N. W. 52nd Avenue
Hialeah, FL 33014
Telephone: (305) 621-1300

NOTE: This office serves Puerto Rico and South America excluding Brazil.



Distributors and Branches - United States

Alabama

Birmingham Distributor

Cummins Alabama, Inc.
2200 Pinson Highway
P.O. Box 1147
Birmingham, AL 35201
Telephone: (205) 841-0421
FAX: (205) 849-5926

Mobile Branch

Cummins Alabama, Inc.
1924 Beltline Highway,
I-65 North
P.O. Box 2566
Mobile, AL 36601
Telephone: (334) 456-2236
FAX: (334) 452-6419

Mobile Onan/Marine Branch

Cummins Alabama, Inc.
3422 Georgia Pacific Avenue
Mobile, AL 36617
Telephone: (334) 452-6426
FAX: (334) 473-6657

Montgomery Branch

Cummins Alabama, Inc.
2325 West Fairview Avenue
P.O. Box 9271
Montgomery, AL 36108
Telephone: (334) 263-2594
FAX: (334) 263-2594

Alaska

Anchorage - (Branch of Seattle)

Cummins Northwest, Inc.
2618 Commercial Drive
Anchorage, AK 99501-3905
Telephone: (907) 279-7594
FAX: (907) 276-6340

Arizona

Phoenix Distributor and Branch

Cummins Southwest, Inc.
2239 North Black Canyon Hwy.
P.O. Box 6688
Phoenix, AZ 85005-6688
Telephone: (602) 252-8021
FAX: (602) 253-6725

Tucson Branch

Cummins Southwest, Inc.
1912 West Prince Road
Tucson, AZ 85705
Telephone: (602) 887-7440
FAX: (602) 887-4173

Arkansas

Little Rock - (Branch of Memphis)

Cummins Mid-South, Inc.
6600 Interstate 30
Little Rock, AR 72209
Telephone:
Sales: (501) 569-5600
Service: (501) 569-5656
Parts: (501) 569-5613
FAX: (501) 565-2199

California

San Leandro Distributor

Cummins West, Inc.
1601 Aurora Drive
San Leandro, CA 94577
Telephone: (510) 351-6101
FAX: (510) 352-3925

Arcata Branch

Cummins West, Inc.
4801 West End Road
Arcata, CA 95521
Telephone: (707) 822-7392
FAX: (707) 822-7585

Bakersfield Branch

Cummins West, Inc.
4601 East Brundage Lane
Bakersfield, CA 93307
Telephone: (805) 325-9404
FAX: (805) 861-8719

Fresno Branch

Cummins West, Inc.
2740 Church Avenue
Fresno, CA 93706
Telephone: (209) 495-4745
FAX: (209) 486-7402

Hayward Distribution Center

Cummins West, Inc.
788 Sandoval Way
Hayward, CA 94544
Telephone: (510) 351-6101
FAX: (510) 429-0957

Redding Branch

Cummins West, Inc.
20247 Charlanne Drive
Redding, CA 96002
Telephone: (916) 222-4070
FAX: (916) 224-4075

San Leandro Branch

Cummins West, Inc.
1601 Aurora Drive
San Leandro, CA 94577
Telephone: (510) 351-6101
FAX: (510) 614-9159

Stockton Branch

Cummins West, Inc.
41 West Yokuts Avenue
Suite 131
Stockton, CA 95207
Telephone: (209) 473-0386
FAX: (209) 478-2454

West Sacramento Branch

Cummins West, Inc.
2661 Evergreen Avenue
West Sacramento, CA 95691
Telephone: (916) 371-0630
FAX: (916) 371-2849

Los Angeles Distributor

Cummins Cal Pacific Inc.
1939 Deere Avenue (Irvine)
Irvine, CA 92714
Telephone: (714) 253-6000
FAX: (714) 253-6070 or 253-6080

Montebello Branch

Cummins Cal Pacific Inc.
1105 South Greenwood Avenue
Montebello, CA 90640
Telephone: (213) 728-8111
FAX: (213) 889-7422

Rialto Branch

Cummins Cal Pacific Inc.
3061 S. Riverside Avenue
Rialto, CA 92377
Telephone: (909) 877-0433
FAX: (909) 877-3787

San Diego Branch

Cummins Cal Pacific Inc.
310 N. Johnson Avenue
El Cajon, CA 92020
Telephone: (619) 593-3093
FAX: (619) 593-0600

Colorado

Denver Distributor

Cummins Rocky Mountain, Inc.
5100 East 58th Avenue
Commerce City, CO 80022
Telephone: (303) 287-0201
FAX: (303) 288-7080

Denver Onan/Industrial Branch

Cummins Rocky Mountain, Inc.
5720 Holly Street, Unit A
Commerce City, CO 80022
Telephone: (303) 286-7697
FAX: (303) 287-4837

Durango Branch

Cummins Rocky Mountain, Inc.
13589 County Road 213
Durango, CO 81301
Telephone: (970) 259-7470
FAX: (970) 259-7482

Grand Junction Branch

Cummins Rocky Mountain, Inc.
2380 U.S. Highway 6 & 50
P.O. Box 339
Grand Junction, CO 81501
Telephone: (303) 242-5776
FAX: (303) 243-5495

Greeley Branch

Cummins Rocky Mountain, Inc.
120 East 18th Street
Greeley, CO 80631
Telephone: (970) 351-0448
FAX: N/A

Connecticut

Hartford Distributor

Cummins - Connecticut, Inc.
260 Murphy Road
Hartford, CT 06114
Telephone: (203) 527-9156
FAX: (203) 527-9955

Florida

Tampa Distributor

Cummins Southeastern Power, Inc.
Corporate Office
5421 N. 59th Street
Tampa, FL 33610
Telephone: (813) 621-7202
FAX: (813) 621-8250

Ft. Myers Branch

Cummins Southeastern Power, Inc.
2671 Edison Avenue, Unit #3
Ft. Myers, FL 33916
Telephone: (813) 337-1211
FAX: (813) 337-5374

Jacksonville Branch

Cummins Southeastern Power, Inc.
2060 West 21st Street
P.O. Box 12036
Jacksonville, FL 32209
Telephone: (904) 355-3437
FAX: (904) 354-4594

Hialeah (Miami) Branch

Cummins Southeastern Power, Inc.
9900 N.W. 77th Court
Hialeah Gardens, FL 33016
Telephone: (305) 821-4200
FAX: (305) 557-2992

Orlando Branch

Cummins Southeastern Power, Inc.
4820 North
Orange Blossom Trail
Orlando, FL 32810
Telephone: (407) 298-2080
FAX: (407) 290-8727

Tampa Branch

Cummins Southeastern Power, Inc.
5910 E. Hillsborough Avenue
P. O. Box 11737
Tampa, FL 33680
Telephone: (813) 626-1101
FAX: (813) 628-4183

Georgia

Atlanta Distributor

Cummins South, Inc.
5125 Georgia Highway 85
College Park, GA 30349-5976
Telephone: (404) 763-0151
FAX: (404) 766-2132

Albany Branch

Cummins South, Inc.
1915 W. Oakridge Drive
Albany, GA 31707-4938
Telephone: (912) 888-6210
FAX: (912) 883-1670

Atlanta Branch

Cummins South, Inc.
100 University Avenue, S.W.
Atlanta, GA 30315-2202
Telephone: (404) 527-7800
FAX: (404) 527-7832

Augusta Branch

Cummins South, Inc.
1255 New Savannah Road
Augusta, GA 30901-3891
Telephone: (706) 722-8825
FAX: (706) 722-7553

Savannah Branch

Cummins South, Inc.
8 Interchange Court
Savannah, GA 31401-1627
Telephone: (912) 232-5565
FAX: (912) 232-5145

Hawaii

Honolulu Distributor

Cummins Hawaii Diesel Power, Inc.
215 Puuhale Road
Honolulu, HI 98619-2235
Telephone: (808) 845-6606
FAX: (808) 842-7546

Idaho

Boise - (Branch of Salt Lake City)

Cummins Intermountain, Inc.
2851 Federal Way
P.O. Box 5212
Boise, ID 83705
Telephone: (208) 336-5000
FAX: N/A

Pocatello - (Branch of Salt Lake City)

Cummins Intermountain, Inc.
14299 Highway 30 West
Pocatello, ID 83201
Telephone: (208) 234-1661
FAX: (208) 234-1662

Illinois

Chicago Distributor

Cummins Northern Illinois, Inc.
7145 Santa Fe Drive
Hodgkins, IL 60525
Telephone: (708) 579-9222
FAX: (708) 352-7547

Bloomington-Normal - (Branch of Indianapolis)

Cummins Mid-States Power, Inc.
P.O. Box 348
(at U.S. 51 N and I-55)
414 W. Northtown Road
Bloomington-Normal, IL 61761
Telephone: (309) 452-4454
FAX: (309) 452-1642

Harrisburg (Branch of St. Louis)

Cummins Gateway, Inc.
Rt. 4, Box 629
Harrisburg, IL 62946
Telephone: (618) 273-4138
FAX: (618) 273-4531

Rock Island - (Branch of Omaha)

Cummins Great Plains Diesel, Inc.
7820 - 42nd Street West
P.O. Box 4445
Rock Island, IL 61204
Telephone: (309) 787-4300
FAX: (309) 787-4397

Indiana

Indianapolis Distributor

Cummins Mid-States Power, Inc.
P.O. Box 42917
3762 West Morris Street
Indianapolis, IN 46242-0917
Telephone: (317) 243-7979
FAX: (317) 240-1925

Evansville - (Branch of Louisville)

Cummins Cumberland, Inc.
7901 Highway 41 North
Evansville, IN 47711
Telephone: (812) 867-4400
FAX: (812) 421-3282

Ft. Wayne Branch

Cummins Mid-States Power, Inc.
3415 Coliseum Blvd. West
(At Jct. I-69 & 30/33)
Ft. Wayne, IN 46808
Telephone: (219) 482-3691
FAX: (219) 484-8930

Gary - (Branch of Chicago)

Cummins Northern Illinois, Inc.
1440 Texas Street
Gary, IN 46402
Telephone: (219) 885-5591
FAX: (219) 883-4817

Indianapolis Branch

Cummins Mid-States Power, Inc.
P. O. Box 42917
3621 West Morris Street
Indianapolis, IN 46242-917
Telephone: (317) 244-7251
FAX: (317) 240-1215

Onan Branch

Mid-States Power & Refrigeration
Division of Cummins Mid-States Power
4301 W. Morris Street
P.O. Box 42917
Indianapolis, IN 46240-0917
Telephone: (317) 240-1867
FAX: (317) 240-1975

Iowa

Cedar Rapids - (Branch of Omaha)

Cummins Great Plains Diesel, Inc.
625 - 33rd Avenue SW
P.O. Box 1107
Cedar Rapids, IA 52406
Telephone: (319) 366-7537 (24 hours)
FAX: (319) 366-7562

Des Moines - (Branch of Omaha)

Cummins Great Plains Diesel, Inc.
1680 N.E. 51st Avenue
P.O. Box B
Des Moines, IA 50313
Telephone: (515) 262-9591
Parts: (515) 262-9744
FAX: (515) 262-0626

Des Moines - (Branch of Omaha)

Midwestern Power Products
Division of Cummins Great Plains Diesel, Inc.
5194 N.E. 17th Street
Des Moines, IA 50313
Telephone: (515) 264-1650
FAX: (515) 264-1651

Kansas

Colby - (Branch of Kansas City, Missouri)

Cummins Mid-America, Inc.
1880 South Range
Colby, KS 67701
Telephone: (913) 462-3945
FAX: (913) 462-3970

Garden City - (Branch of Kansas City, Missouri)

Cummins Mid-America, Inc.
2208 West Mary
Garden City, KS 67846
Telephone: (316) 275-2277
FAX: (316) 275-2533

Wichita - (Branch of Kansas City, Missouri)

Cummins Mid-America, Inc.
5101 North Broadway
Wichita, KS 67219
Telephone: (316) 838-0875
FAX: (316) 838-0704

Kentucky

Louisville Distributor

Cummins Cumberland, Inc.
(Corporate Office)
304 Whittington Parkway
Suite 200
Louisville, KY 40220
Telephone: (502) 426-9300
FAX: (502) 327-9851

Hazard Branch

Cummins Cumberland, Inc.
Highway 15 South
P.O. Box 510
Hazard, KY 41701
Telephone: (606) 436-5718
FAX: (606) 436-4038

Louisville Branch

Cummins Cumberland, Inc.
9820 Bluegrass Parkway
Louisville, KY 40299
Telephone: (502) 491-4263
FAX: (502) 499-0896

Louisiana

Morgan City - (Branch of Memphis)

Cummins Mid-South, Inc.
Hwy. 90 East
P.O. Box 1229
Amelia, LA 70340
Telephone: (504) 631-0576
FAX: (504) 631-0081

New Orleans - (Branch of Memphis)

Cummins Mid-South, Inc.
110 E. Airline Highway
Kenner, LA 70062
Telephone: (504) 468-3535
FAX: (504) 465-3408

Maine

Bangor (Branch of Boston)

Cummins Northeast, Inc.
142 Target Industrial Circle
Bangor, ME 04401
Telephone: (207) 941-1061
FAX: (207) 945-3170

Scarborough - (Branch of Boston)

Cummins Northeast, Inc.
10 Gibson Road
Scarborough, ME 04074
Telephone: (207) 883-8155
FAX: (207) 883-5526

Maryland

Baltimore Distributor

Cummins Chesapeake Power, Inc.
6120 Holabird Avenue
Baltimore, MD 21224-6198
Telephone: (410) 633-5161
FAX: (410) 633-6031/5540

Baltimore Branch

Cummins Chesapeake Power, Inc.
3140 Washington Boulevard
Baltimore, MD 21230-1090
Telephone: (410) 644-6500
FAX: (410) 644-2438

Massachusetts

Boston Distributor

Cummins Northeast, Inc.
100 Allied Drive
Dedham, MA 02026
Telephone: (617) 329-1750
FAX: (617) 329-4428

West Springfield Branch

Cummins Northeast, Inc.
177 Rocus Street
Springfield, MA 01104
Telephone: (413) 737-2659
FAX: (413) 731-1082

Mexico

Tijuana - (Branch of Los Angeles)

Distribuidora Cummins De Baja
Blvd. 3ra. Oeste No. 17523
Fracc. Industrial
Garita de Otay C.P. 22400
Tijuana, Baja California
Mexico
Telephone: 011-52-66-238433
FAX: 011-52-66-238649

Michigan

Detroit (Novi) Distributor

Cummins Michigan, Inc.
41216 Vincenti Court
Novi, MI 48375
Telephone: (810) 478-9700
FAX: (810) 478-1570

Blissfield, Michigan

Diesel Fuel Systems, Inc.
Subsidiary of Cummins Michigan Inc.
211 N. Jipson Street
Blissfield, MI 49228
Telephone: (517) 486-4324
FAX: (517) 486-3614

Dearborn Branch

Cummins Michigan, Inc.
3760 Wyoming Avenue
Dearborn, MI 48120
Telephone: (313) 843-6200
FAX: (313) 843-6070

Grand Rapids Branch

Cummins Michigan, Inc.
3715 Clay Avenue, S.W.
Grand Rapids, MI 49508
Telephone: (616) 538-2250
FAX: (616) 538-3830

Grand Rapids Branch

Standby Power, Inc.
7580 Expressway Drive S.W.
Grand Rapids, MI 49548
Telephone: (616) 281-2211
FAX: (616) 281-3177

Iron Mountain - (Branch of De Pere)

Cummins Great Lakes, Inc.
P.O. Box 703
1901 Stevenson Avenue
Iron Mountain, MI 49801
Telephone: (906) 774-2424
(800) 236-2424
FAX: (906) 774-1190

Novi Branch

Cummins Michigan, Inc.
25100 Novi Road
Novi, MI 48375
Telephone: (810) 380-4300
FAX: (810) 380-0910

Saginaw Branch

Cummins Michigan, Inc.
722 N. Outer Drive
Saginaw, MI 48605
Telephone: (517) 752-5200
FAX: (517) 752-4194

Standby Power - (Branch of Detroit)

Standby Power, Inc.
12130 Dixie
Redford, MI 48239
Telephone: (313) 538-0200
FAX: (313) 538-3966

Minnesota

St. Paul Distributor

Cummins Diesel Sales, Inc.
2690 Cleveland Avenue North
St. Paul, MN 55113
Mailing Address:
P.O. Box 64578
St. Paul, MN 55164
Telephone: (612) 636-1000
FAX:
Office/Sales: (612) 638-2442
Parts/Service: (612) 638-2497

Duluth Branch

Cummins Diesel Sales, Inc.
3115 Truck Center Drive
Duluth, MN 55806-1786
Telephone: (218) 628-3641
FAX: (218) 628-0488

Hibbing Branch

Cummins Diesel Sales, Inc.
604 West 41st Street
P.O. Box 159
Hibbing, MN 55746
Telephone: (218) 263-7558
FAX: (218) 263-7400

Mississippi

Jackson - (Branch of Memphis)

Cummins Mid-South, Inc.
325 New Highway 49 South
P.O. Box 54224
Jackson, MS 39288-4224
Telephone:
Admin.: (601) 932-7016
Parts: (601) 932-2720
Service: (601) 939-1800
FAX: (601) 932-7399

Missouri

Kansas City Distributor

Cummins Mid-America, Inc.
1760 Universal
P.O. Box 4985
Kansas City, MO 64120
General Accounting Office
Telephone: (816) 483-5070
FAX: (816) 483-5013

Kansas City Branch

Cummins Mid-America, Inc.
3527 Gardner Avenue
Kansas City, MO 64120
Telephone: (816) 483-6313
FAX: (816) 483-4073

Kansas City Fuel Systems Branch

Cummins Mid-America, Inc.
2810 Nicholson
Kansas City, MO 64120
Telephone: (816) 241-3400
FAX: (816) 241-5434

Joplin Branch

Cummins Mid-America, Inc.
3507 East 20th Street
Joplin, MO 64801
Telephone: (417) 623-1661
FAX: (417) 623-1817

Springfield Branch

Cummins Mid-America, Inc.
3637 East Kearney
Springfield, MO 65803
Telephone: (417) 862-0777
FAX: (417) 862-4429

St. Louis Distributor

Cummins Gateway, Inc.
7210 Hall Street
St. Louis, MO 63147
Telephone: (314) 389-5400
FAX: (314) 389-9671

Columbia Branch

Cummins Gateway, Inc.
5221 Highway 763 North
Columbia, MO 65202-1028
Telephone: (314) 449-3711
FAX: (314) 449-3712

Sikeston Branch

Cummins Gateway, Inc.
101 Keystone Drive
Sikeston, MO 63801
Telephone: (314) 472-0303
FAX: (314) 472-0306

Montana

Billings - (Branch of Denver)

Cummins Rocky Mountain, Inc.
5151 Midland Road
P.O. Box 30377
Billings, MT 59101
Telephone: (406) 245-4194
FAX: (406) 245-7923

Great Falls - (Branch of Denver)

Cummins Rocky Mountain, Inc.
415 Vaughn Road (59404)
P.O. Box 1199
Great Falls, MT 59403
Telephone: (406) 452-8561
FAX: (406) 452-9911

Missoula - (Branch of Seattle)

Cummins Northwest, Inc.
4950 North Reserve Street
Missoula, MT 59802-1498
Telephone: (406) 728-1300
FAX: (406) 728-8523

Nebraska

Omaha Distributor and Branch

Cummins Great Plains Diesel, Inc.
5515 Center Street
P.O. Box 6068
Omaha, NE 68106
Telephone: (402) 551-7678 (24 Hours)
FAX: (402) 551-1952

Kearney Branch

Cummins Great Plains Diesel, Inc.
515 Central Avenue
P.O. Box 1326
Kearney, NE 68847
Telephone: (308) 294-1994
FAX: (308) 234-5776

Nevada

Elko - (Branch of Salt Lake City)

Cummins Intermountain, Inc.
5370 East Idaho Street
Elko, NV 89801
Telephone: (702) 738-6405
FAX: (702) 738-1719

Las Vegas - (Branch of Salt Lake City)

Cummins Intermountain, Inc.
2750 Losee Road
North Las Vegas, NV 89036
Mailing Address:
P.O. Box 3997
North Las Vegas, NV 89036-3998
Telephone: (702) 399-2339
FAX: (702) 399-7457

Sparks - (Branch of Salt Lake City)

Cummins Intermountain, Inc.
150 Glendale Avenue
Sparks, NV 89431
Telephone: (702) 331-4983
FAX: (702) 331-7429

New Jersey

Newark - (Branch of Bronx)

Cummins Metropower, Inc.
41-85 Doremus Ave.
Newark, NJ 07105
Telephone: (201) 242-2255
FAX: (201) 242-6142

New Mexico

Albuquerque - (Branch of Phoenix)

Cummins Southwest, Inc.
1921 Broadway N.E.
Albuquerque, NM 87102
Telephone: (505) 247-2441
FAX: (505) 842-0436

Farmington - (Branch of Phoenix)

Cummins Southwest, Inc.
1101 North Troy King Road
Farmington, NM 87401
Telephone: (505) 327-7331
FAX: (505) 326-2948

New York

Bronx Distributor

Cummins Metropower, Inc.
890 Zerega Avenue
Bronx, NY 10473
Telephone: (718) 892-2400
FAX: (718) 892-0055

Albany - (Branch of Boston)

Cummins Northeast, Inc.
101 Railroad Avenue
Albany, NY 12205
Telephone: (518) 459-1710
FAX: (518) 459-7815

Buffalo - (Branch of Boston)

Cummins Northeast, Inc.
480 Lawrence Bell Dr.
Williamsville, NY 14221-7090
Telephone: (716) 631-3211
FAX: (716) 626-0799

Syracuse - (Branch of Boston)

Cummins Northeast, Inc.
6193 Eastern Avenue
Syracuse, NY 13211
Telephone: (315) 437-2751
FAX: (315) 437-8141

North Carolina

Charlotte Distributor

Cummins Atlantic, Inc.
11101 Nations Ford Road (28273)
P.O. Box 240729
Charlotte, NC 28224-0729
Telephone: (704) 588-1240
FAX: (704) 587-4870

Charlotte Branch

Cummins Atlantic, Inc.
3700 North Interstate 85
Charlotte, NC 28206
Telephone: (704) 596-7690
FAX: (704) 596-3038

Greensboro Branch

Cummins Atlantic, Inc.
513 Preddy Boulevard (27406)
P.O. Box 22066
Greensboro, NC 27420-2066
Telephone: (910) 275-4531
FAX: (910) 275-8304

Wilson Branch

Cummins Atlantic, Inc.
1514 Cargill Avenue (27893)
P.O. Box 1177
Wilson, NC 27894-1117
Telephone: (919) 237-9111
FAX: (919) 237-9132

North Dakota

Fargo - (Branch of St. Paul)

Cummins Diesel Sales, Inc.
4050 West Main Avenue (58103)
P.O. Box 2111
Fargo, ND 58107
Telephone: (701) 282-2466
FAX: (701) 281-2543

Grand Forks - (Branch of St. Paul)

Cummins Diesel Sales, Inc.
4728 Gateway Drive (58201)
P.O. Box 12637
Grand Forks, ND 58208-2637
Telephone: (701) 775-8197
FAX: (701) 775-4833

Minot - (Branch of St. Paul)

Cummins Diesel Sales, Inc.
1501 - 20th Avenue, S.E. (58701)
P.O. Box 1179
Minot, ND 58702
Telephone: (701) 852-3585
FAX: (701) 852-3588

Ohio

Columbus Distributor and Branch

Cummins Ohio, Inc.
4000 Lyman Drive
Hilliard (Columbus), OH 43026
Telephone: (614) 771-1000
FAX: (614) 771-0769

Akron Branch

Cummins Ohio, Inc.
1033 Kelly Avenue
Akron, OH 44306
Telephone: (216) 773-7821
FAX: (216) 773-2201

Cincinnati Branch

Cummins Ohio, Inc.
10470 Evendale Drive
Cincinnati, OH 45241
Telephone: (513) 563-6670
FAX: (513) 563-0594

Cleveland Branch

Cummins Ohio, Inc.
7585 Northfield Road
Cleveland, OH 44146
Telephone: (216) 439-6800
FAX: (216) 439-7390

Lima Branch

Cummins Ohio, Inc.
960 Broadway St.
Lima, OH 45804
Telephone: (419) 227-2641
FAX: (419) 225-5506

Strasburg Branch

Cummins Ohio, Inc.
777 South Wooster Avenue
Box 136
Strasburg, OH 44680
Telephone: (216) 878-5511
FAX: (216) 878-7666

Toledo Branch

Cummins Ohio, Inc.
801 Illinois Avenue
Maumee
(Toledo), OH 43537
Telephone: (419) 893-8711
FAX: (419) 893-5362

Youngstown Branch

Cummins Ohio, Inc.
7145 Masury Road
Hubbard
(Youngstown), OH 44425
Telephone: (216) 534-1935
FAX: (216) 534-5606

Oklahoma

Oklahoma City - (Branch of Arlington)

Cummins Southern Plains, Inc.
5800 West Reno
P.O. Box 1636
Oklahoma City, OK 73101-1636
Telephone: (405) 946-4481 (24 hours)
FAX: (405) 946-3336

Tulsa - (Branch of Arlington)

Cummins Southern Plains, Inc.
9725 E. Admiral Place
P.O. Box 471616
Tulsa, OK 74147-1616
Telephone: (918) 838-2555 (24 hours)
FAX: (918) 838-9818

Oregon

Bend - (Branch of Seattle)

Cummins Northwest, Inc.
3500 N. Highway 97 (97701-5729)
P.O. Box 309
Bend, OR 97709-0309
Telephone: (503) 389-1900
FAX: (503) 389-1909

Coburg/Eugene - (Branch of Seattle)

Cummins Northwest, Inc.
91201 Industrial Parkway
Coburg, OR 97401
(Mailing Address)
P.O. Box 10877
Eugene, OR 97440-2887
Telephone: (503) 687-0000
FAX: (503) 687-1977

Medford - (Branch of Seattle)

Cummins Northwest, Inc.
4045 Crater Lake Highway
Medford, OR 97504-9796
Telephone: (503) 779-0151
FAX: (503) 772-2395

Pendleton - (Branch of Seattle)

Cummins Northwest, Inc.
223 S.W. 23rd Street
Pendleton, OR 97801-1810
Telephone: (503) 276-2561
FAX: (503) 276-2564

Portland - (Corporate Branch of Seattle)

Cummins Northwest, Inc.
4711 N. Basin Avenue
P.O. Box 2710 (97208-2710)
Portland, OR 97217-3557
Telephone: (503) 289-0900
FAX: (503) 286-5938

Portland - (Branch of Seattle)

Cummins Northwest, Inc.
4711 N. Basin Avenue
P. O. Box 2710 (97208-2710)
Portland, OR 97217-3557
Telephone: (503) 289-0900
FAX: (503) 286-5938

Pennsylvania

Philadelphia Distributor

Cummins Power Systems, Inc.
2727 Ford Road
Bristol, PA 19007-6895
Telephone: (215) 785-6005 and
(609) 563-0005
FAX: (215) 785-4085

Bristol Branch

Cummins Power Systems, Inc.
2727 Ford Road
Bristol, PA 19007-6895
Telephone: (215) 785-6005 and
(609) 563-0005
FAX: (215) 785-4728

Clearfield Branch

Cummins Power Systems, Inc.
501 Williams Street
Clearfield, PA 16830-1426
Telephone: (814) 765-2421
FAX: (814) 765-2988

Harmar Branch

Cummins Power Systems, Inc.
3 Alpha Drive
Harmar, PA 15238-2901
Telephone: (412) 820-8300
FAX: (412) 820-8308

Harrisburg Branch

Cummins Power Systems, Inc.
4499 Lewis Road
Harrisburg, PA 17111-2541
Telephone: (717) 564-1344
FAX: (717) 558-8217

Monroeville Branch

Cummins Power Systems, Inc.
2740 Mossie Boulevard
Monroeville, PA 15146-2712
Telephone: (412) 856-6700
FAX: (412) 856-9822

Puerto Rico

Puerto Nuevo - (Branch of Tampa)

Cummins Diesel Power, Inc.
#31 Calle "C"
El Matadero
Puerto Nuevo, Puerto Rico 00920
Telephone: (809) 793-0300
FAX: (809) 793-1072

South Carolina

Charleston - (Branch of Charlotte)

Cummins Atlantic, Inc.
3028 Montague Avenue
Charleston, SC 29418
Telephone: (803) 554-5112
FAX: (803) 745-0745

Charleston - (Onan Branch of Charlotte)

Cummins Atlantic Inc.
Atlantic Power Generation
3028 West Montague Avenue
Charleston, SC 29418
Telephone: (803) 554-9804
FAX: (803) 745-0745

Columbia - (Branch of Charlotte)

Cummins Atlantic, Inc.
1233 Bluff Road (29201)
P.O. Box 13543
Columbia, SC 29201-3543
Telephone: (803) 799-2410
FAX: (803) 779-3427

South Dakota

Sioux Falls - (Branch of Omaha)

Cummins Great Plains Diesel, Inc.
701 East 54th Street North
Sioux Falls, SD 57104
Telephone: (605) 336-1715
FAX: (605) 336-1748

Tennessee

Memphis Distributor & Distribution Center

Cummins Mid-South, Inc.
666 Riverside Drive
P.O. Box 3080
Memphis, TN 38103
Telephone: (901) 577-0666
FAX: (901) 522-8758

Chattanooga - (Branch of Atlanta)

Cummins South, Inc.
1509 East 26th Street
Chattanooga, TN 37407-1095
Telephone: (615) 629-1447
FAX: (615) 629-1494

Knoxville - (Branch of Louisville)

Cummins Cumberland, Inc.
1211 Ault Road
Knoxville, TN 37914
Telephone: (615) 523-0446
FAX: (615) 523-0343

Memphis Branch

Cummins Mid-South, Inc.
1784 E. Brooks Road
Memphis, TN 38116
Telephone:
Sales/Admin.: (901) 345-7424
Parts: (901) 345-1784
Service: (901) 345-6185
FAX: (901) 346-4735

Nashville - (Branch of Louisville)

Cummins Cumberland, Inc.
706 Spence Lane
Nashville, TN 37217
Telephone: (615) 366-4341
FAX: (615) 366-5693

Texas

Arlington Distributor

Cummins Southern Plains, Inc.
600 N. Watson Road
P.O. Box 90027
Arlington, TX 76004-3027
Telephone: (817) 640-6801 (24 Hours)
FAX: (817) 640-6852

Amarillo Branch

Cummins Southern Plains, Inc.
5224 Interstate 40 -
Expressway East
P.O. Box 31570
Amarillo, TX 79120-1570
Telephone: (806) 373-3793 (24 hours)
FAX: (806) 372-8547

Corpus Christi Branch

Cummins Southern Plains, Inc.
1302 Corn Products Road
P.O. Box 48
Corpus Christi, TX 78403-0048
Telephone: (512) 289-0700 (24 hours)
FAX: (512) 289-7355

Dallas Branch

Cummins Southern Plains, Inc.
3707 Irving Boulevard
Dallas, TX 75247
Telephone: (214) 631-6400 (24 hours)
FAX: (214) 631-2322

El Paso - (Branch of Phoenix)

Cummins Southwest, Inc.
14333 Gateway West
El Paso, TX 79927
Telephone: (915) 852-4200
FAX: (915) 852-3295

Fort Worth Branch

Cummins Southern Plains, Inc.
3250 North Freeway
Fort Worth, TX 76111
Telephone: (817) 624-2107 (24 hours)
FAX: (817) 624-3296

Houston Branch

Cummins Southern Plains, Inc.
4750 Homestead Road
P.O. Box 1367
Houston, TX 77251-1367
Telephone: (713) 675-7421 (24 hours)
FAX: (713) 675-1515

Mesquite Branch

Cummins Southern Plains, Inc.
2615 Big Town Blvd.
Mesquite, TX 75150
Telephone: (214) 321-5555 (24 hours)
FAX: (214) 328-2732

Odessa Branch

Cummins Southern Plains, Inc.
1210 South Grandview
P.O. Box 633
Odessa, TX 79760-0633
Telephone: (915) 332-9121 (24 hours)
FAX: (915) 333-4655

San Antonio Branch

Cummins Southern Plains, Inc.
6226 Pan Am Expressway North
P.O. Box 18385
San Antonio, TX 78218-0385
Telephone: (512) 655-5420 (24 hours)
FAX: (512) 655-3865

Stafford Onan Branch

Southern Plains Power
A Division of Cummins Southern Plains
11100 W. Airport Blvd.
Stafford, TX 77477
Mailing Address:
P.O. Box 2088
Houston, TX 77252-2088
Telephone: (713) 879-2828
FAX: (713) 879-2867

Utah

Salt Lake City Distributor

Cummins Intermountain, Inc.
1030 South 300 West
P.O. Box 25428
Salt Lake City, UT 84125
Telephone: (801) 355-6500
FAX: (801) 524-1351

Vernal Branch

Cummins Intermountain, Inc.
1435 East 335 South
P.O. Box 903
Vernal, UT 84078
Telephone: (801) 789-5732
FAX: N/A

Virginia

Richmond - (Branch of Charlotte)

Cummins Atlantic, Inc.
3900 Deepwater Terminal Road
Richmond, VA 23234
Telephone: (804) 232-7891
FAX: (804) 232-7428

Roanoke - (Branch of Charlotte)

Cummins Atlantic, Inc.
5307 Peters Creek Road
P.O. Box 7237
Roanoke, VA 24019-7237
Telephone: (703) 362-1673
FAX: (703) 362-1304

Tidewater - (Branch of Charlotte)

Cummins Atlantic, Inc.
Atlantic Power Generation
3729 Holland Blvd.
Chesapeake, VA 23323
Telephone: (804) 485-4848
FAX: (804) 485-5085

Washington

Seattle Distributor

Cummins Northwest, Inc.
811 S.W. Grady Way (98055-2944)
P.O. Box 9811
Renton, WA 98057-9811
Telephone: (206) 235-3400
FAX: (206) 235-8202

Chehalis Branch

Cummins Northwest, Inc.
1200 N.W. Maryland
Chehalis, WA 98532-1813
Telephone: (206) 748-8841
FAX: (206) 748-8843

Spokane Branch

Cummins Northwest, Inc.
East 3904 Trent Avenue (99202-4471)
P.O. Box 2746 -
Terminal Annex
Spokane, WA 99220-2746
Telephone: (509) 534-0411
FAX: (509) 534-0416

Tacoma Branch

Cummins Northwest, Inc.
3701 Pacific Highway East
Tacoma, WA 98424-1135
Telephone: (206) 922-2191
FAX: (206) 922-2379

Yakima Branch

Cummins Northwest, Inc.
1905 East Central Avenue (98901-3609)
P.O. Box 9129
Yakima, WA 98909-0129
Telephone: (509) 248-9033
FAX: (509) 248-9035

West Virginia

Charleston - (Branch of Louisville)

Cummins Cumberland, Inc.
Charleston Ordnance Center
P.O. Box 8456
South Charleston, WV 25303
Telephone: (304) 744-6373
FAX: (304) 744-8605

Fairmont - (Branch of Louisville)

Cummins Cumberland, Inc.
South Fairmount Exit, I-79
145 Middletown Road
Fairmont, WV 26554
Telephone: (304) 367-0196
FAX: (304) 367-1077

Wisconsin

DePere Distributor

Cummins Great Lakes, Inc.
Corporate Office
875 Lawrence Drive
P.O. Box 530
DePere (Green Bay), WI 54115
Telephone: (414) 337-1991
FAX: (414) 337-9746

Chippewa Falls Branch

Cummins Great Lakes, Inc.
4860 Hallie Road
Chippewa Falls, WI 54729
Telephone: (715) 720-0680
FAX: (715) 720-0685

DePere Branch

Cummins Great Lakes, Inc.
939 Lawrence Drive
P. O. Box 530
DePere (Green Bay), WI 54115
Telephone: (414) 336-9631
(800) 236-1191
FAX: (414) 336-8984

Milwaukee Branch

Cummins Great Lakes, Inc.
9401 South 13th Street
P.O. Box D
Oak Creek, WI 53154
Telephone: (414) 768-7400
(800) 472-8283
FAX: (414) 768-9441

Wausau Branch

Cummins Great Lakes, Inc.
4703 Rib Mountain Drive
Wausau, WI 54401
Telephone: (715) 359-6888
(800) 236-3744
FAX: (715) 359-3744

Wyoming

Gillette - (Branch of Denver)

Cummins Rocky Mountain, Inc.
2700 Hwy. 14 & 16 North
P.O. Box 1207 (82717)
Gillette, WY 82716
Telephone: (307) 682-9611
FAX: (307) 682-8242

Rock Springs - (Branch of Salt Lake City)

Cummins Intermountain, Inc.
2000 Foothill Blvd.
P.O. Box 1634
Rock Springs, WY 82901
Telephone: (307) 362-5168
FAX: (307) 362-5171

Distributors and Branches - Canada

Alberta

Edmonton Distributor

Cummins Alberta
14755 - 121A Avenue
Edmonton, Alberta T5L 2T2, Canada
Telephone: (403) 455-2151
FAX: (403) 454-9512

Calgary Branch

Cummins Alberta
4887 - 35th Street S.E.
Calgary, Alberta T2B 3H6, Canada
Telephone: (403) 569-1122
FAX: (403) 569-0027

Hinton Branch

Cummins Alberta
135 Veats Avenue
Hinton, Alberta T7V 1S8, Canada
Telephone: (403) 865-5111
FAX: (403) 865-5714

Lethbridge Branch

Cummins Alberta
240 - 24th Street North
Lethbridge, Alberta T1H 3T8, Canada
Telephone: (403) 329-6144
FAX: (403) 320-5383

British Columbia

Vancouver Distributor

Cummins British Columbia
18452 - 96th Avenue
Surrey, B.C., Canada
V4N 3P8
Telephone: (604) 882-5000
FAX: (604) 882-5080

Kamloops Branch

Cummins British Columbia
976 Laval Crescent
Kamloops, B.C. Canada V2C 5P5
Telephone: (604) 828-2388
FAX: (604) 828-6713

Prince George Branch

Cummins British Columbia
102- 3851- 18th Avenue
Prince George, B.C. V2N 1B1
Telephone: (604) 564-9111
FAX: (604) 564-5853

Sparwood Branch

Cummins British Columbia
731 Douglas Fir Road
Sparwood, B.C. VOB 2G0, Canada
Telephone: (604) 425-0522
FAX: (604) 425-0323

Tumbler Ridge Branch

Cummins British Columbia
Industrial Site, Box 226
Tumbler Ridge, B.C.
Canada VOC 2W0
Telephone: (604) 242-4217
FAX: (604) 242-4906

Manitoba

Winnipeg Distributor

Cummins Mid-Canada Ltd.
489 Oak Point Road
P.O. Box 1860
Winnipeg, MB R3C 3R1, Canada
Telephone: (204) 632-5470
FAX: (204) 697-0267

New Brunswick

Fredericton - (Branch of Montreal)

Cummins Diesel
Branch of Cummins Americas, Inc.
R.R.#1 Doak Road
Fredericton,
New Brunswick E3B 4X2, Canada
Telephone: (506) 451-1929
FAX: (506) 451-1921

Newfoundland

St. John's - (Branch of Montreal)

Cummins Diesel
Branch of Cummins Americas, Inc.
122 Clyde Avenue
Donovans Industrial Park
Mount Pearl, Newfoundland A1N 4S3
Canada
Telephone: (709) 747-0176
FAX: (709) 747-2283

Wabush - (Branch of Montreal)

Cummins Diesel
Branch of Cummins Americas, Inc.
Wabush Industrial Park
Wabush, Newfoundland A0R 1B0
Telephone: (709) 282-3626
FAX: (709) 282-3108

Nova Scotia

Halifax - (Branch of Montreal)

Cummins Diesel
Branch of Cummins Americas, Inc.
50 Simmonds Drive
Dartmouth, Nova Scotia B3B 1R3
Telephone: (902) 468-7938
FAX: (902) 468-5177
Parts: (902) 468-6560

Ontario

Toronto Distributor

Cummins Ontario Inc.
Corporate Office & Parts Distribution
Centre
301 Wyecroft Road
Oakville, Ontario L6K 2H2, Canada
Telephone: (905) 844-5851
FAX: (905) 844-7040

Toronto Branch

Cummins Ontario Inc.
150 N. Queen Street
Etobicoke, Ontario, Canada M9C 1A8
Telephone: (416) 621-9921
FAX: (416) 633-8343

Kenora - (Branch of Winnipeg)

Cummins Mid-Canada Ltd.
P.O. Box 8
Kenora, Ontario P9N 3X1
Telephone: (807) 548-1941
FAX: (807) 548-8302

Ottawa Branch

Cummins Ontario Inc.
3189 Swansea Crescent
Ottawa, Ontario K1G 3W5, Canada
Telephone: (613) 736-1146
FAX: (613) 736-1202

Thunder Bay Branch

Cummins Ontario Inc.
1400 W. Walsh Street
Thunder Bay
Ontario P7E 4X4
Telephone: (807) 577-7561
FAX: (807) 577-1727

Whitby Branch

Cummins Ontario Inc.
1311 Hopkins Street
Whitby, Ontario L1N 2C2, Canada
Telephone: (905) 668-6886
FAX: (905) 668-1375

Quebec

Montreal Distributor

Cummins Diesel
Branch of Cummins Americas, Inc.
7200 Trans Canada Highway
Pointe Claire, Quebec H9R 1C2,
Canada
Telephone: (514) 695-8410
FAX: (514) 695-8917

Montreal Branch

Cummins Diesel
Branch of Cummins Americas, Inc.
7200 Trans Canada Highway
Pointe Claire, Quebec H9R 1C2,
Canada
Telephone: (514) 695-8410
Sales: (514) 695-4555
Parts: (514) 694-5880
FAX: (514) 695-8917

Quebec City Branch

Cummins Diesel
Branch of Cummins Americas, Inc.
2400 Watt Street
Ste. Foy, Quebec G1P 3T3, Canada
Telephone: (418) 651-2911
FAX: (418) 651-0965
Parts: (418) 651-8434

Saskatchewan

Lloydminster - (Branch of Winnipeg)

Cummins Mid-Canada Ltd.
3709 - 44th Street
P.O. Box 959
Lloydminster, SK S9V 0Y9
Telephone: (306) 825-2062
FAX: (306) 825-6702

Regina - (Branch of Winnipeg)

Cummins Mid-Canada Ltd.
110 Kress Street
P.O. Box 98
Regina, SK S4P 2Z5, Canada
Telephone: (306) 721-9710
FAX: (306) 721-2962

Saskatoon - (Branch of Winnipeg)

Cummins Mid-Canada, Ltd.
3001 Faithful Avenue
P.O. Box 7679
Saskatoon, SK S7K 4R4, Canada
Telephone: (306) 933-4022
FAX: (306) 242-1722

Distributors and Branches - Australia

Sydney (Lansvale)

Cummins Diesel Sales & Service
P.O. Box 150
Cambramatta, 2166
New South Wales, Australia
Location:
164-170 Hume Highway
Lansvale, 2166, Australia
Telephone: (61-2) 728-6211

Branches:

Adelaide

Cummins Diesel Sales & Service
P.O. Box 108
Blair Athol, 5084
South Australia, Australia
Location:
45-49 Cavan Road
Gepps Cross, 5094
Telephone: (61-8) 262-5211

Brisbane

Cummins Diesel Sales & Service
P.O. Box 124
Darra, 4076
Queensland, Australia
Location:
33 Kimberley Street
Darra, 4076, Australia
Telephone: (61-7) 375-3277

Cairns

Cummins Diesel Sales & Service
P.O. Box 7189
Cairns Mail Centre, 4870
Queensland, Australia
Location:
Cnr. Toohey & Knight Streets
Portsmith, Cairns, 4870
Telephone: (61-70) 35-1400

Campbellfield

Cummins Diesel Sales & Service
Private Bag 9
Campbellfield, 3061
Victoria, Australia
Location:
1788-1800 Hume Highway
Campbellfield, 3061
Telephone: (613) 357-9200

Dandenong

Cummins Diesel Sales & Service
Lot 7 Greens Road
Dandenong, 3175
Victoria, Australia
Telephone: (613) 706-8088

Darwin

Cummins Diesel Sales & Service
P.O. Box 37587
Winnellie, 0821
Northern Territory, Australia
Location:
Lot 1758 Graffin Crescent
Winnellie, 0821
Telephone: (61-89) 47-0766

Devonport

Cummins Diesel Sales & Service
P.O. Box 72E
Tasmania, Australia
Location:
2 Matthews Way
Devonport, 7310
Telephone: (61-04) 24-8800

Emerald

Cummins Diesel Sales & Service
P.O. Box 668
Emerald, 4720
Queensland, Australia
Location:
Capricorn Highway
Emerald, 4720
Telephone: (61-79) 82-4022

Grafton

Cummins Diesel Sales & Service
P.O. Box 18
South Grafton, 2461
New South Wales, Australia
Location:
18-20 Induna Street
South Grafton, 2461
Telephone: (61-66) 42-3655

Hexham

Cummins Diesel Sales & Service
21 Galleghan Street
Hexham, 2322
New South Wales, Australia
Telephone: (61-49) 64-8466

Kalgoorlie

Cummins Diesel Sales & Service
P.O. Box 706
Kalgoorlie, 6430
Western Australia, Australia
Location:
16 Atbara Street
Kalgoorlie, 6430
Telephone: (61-90) 21-2588 or 21-2994

Mackay

Cummins Diesel Sales & Service
P.O. Box 842
Mackay, 4740
Queensland, Australia
Location:
4 Presto Avenue
Mackay, 4746
Telephone: (61-79) 55-1222

Mount Gambier

Cummins Diesel Sales & Service
P.O. Box 2219
Mount Gambier, 5290
South Australia, Australia
Location:
2 Avey Road
Mount Gambier, 5290
Telephone: (61-87) 25-6422

Penrith

Cummins Diesel Sales & Service
P.O. Box 132
Cambridge Park, 2747
New South Wales, Australia
Location:
7 Andrews Road
Penrith, 2750
Telephone: (61-47) 29-1313

Queanbeyan

Cummins Diesel Sales & Service
P.O. Box 527
Queanbeyan, 2620
New South Wales, Australia
Location:
15-27 Bayldon Road
Queanbeyan, 2620
Telephone: (61-62) 97-3433

Swan Hill

Cummins Diesel Sales & Service
P.O. Box 1264
Swan Hill, 3585
Victoria, Australia
Location:
5 McAllister Road
Swan Hill, 3585
Telephone: (61-50) 32-1511

Tamworth

Cummins Diesel Sales & Service
P.O. Box 677
Tamworth, 2320
New South Wales, Australia
Location:
Lot 65 Gunnedah Road
Tamworth, 2340
Telephone: (61-67) 65-5455

Welshpool

Cummins Diesel Sales & Service
P. O. Box 52
Welshpool, 6986
Western Australia, Australia
Location:
50 Kewdale Road
Welshpool, 6106
Telephone: (61-9) 458-5911

Wodonga

Cummins Diesel Sales & Service
P.O. Box 174
Wodonga, 3690
Victoria, Australia
Location:
9-11 McKoy Street
Wodonga, 3690
Telephone: (61-60) 24-3655

Distributors and Branches - New Zealand

Auckland

Cummins Diesel Sales & Service (NZ)
Ltd.
Private Bag 92804
Penrose, Auckland, New Zealand
Location:
440 Church Street
Penrose
Telephone: (64-9) 579-0085

Branches:

Auckland

Cummins Diesel Engines
Private Bag 92804
Penrose, Auckland, New Zealand
Location:
440 Church Street
Penrose
Telephone: (64-9) 579-0085

Christchurch

Cummins Diesel Engines
P.O. Box 16-149
Hornby, Christchurch, New Zealand
Location:
35 Parkhouse Road
Sockburn, Christchurch
Telephone: (64-3) 348-8170

Mt. Maunganui

Cummins Diesel Engines
P.O. Box 4005
Mt. Maunganui, New Zealand
Location:
101 Totara Street
Mt. Maunganui
Telephone: (64-7) 575-0545

Palmerston North

Cummins Diesel Engines
P.O. Box 9024
Palmerston North, New Zealand
Location:
852-860 Tremaine Avenue
Telephone: (64-6) 356-2209

Regional Offices - International

North Africa Regional Office - Algiers

Cummins Corporation
Bureau de Liaison
38, Lotissement Benachour Abdelkader
Cheraga
42300 Wilaya de Tipasa
Algeria
Telephone: (213) 2374326

Country
Covered: Algeria

European Regional Office - Mechelen

Cummins Diesel N.V.
Blarenberglaan 4
Industriepark Noord 2
2800 Mechelen
Brussels
Telephone: (32-15) 20003

Countries
Covered: Austria Luxembourg
Belgium Netherlands
Czech Republic Norway
Denmark Portugal
Finland Slovakia
Greece Spain
Hungary Sweden
Iceland Switzerland
Israel

Cumbrasa Regional Office - Brazil

Cummins Brasil S.A.
Rua Jati, 266
07180-900 Guarulhos
Sao Paulo, Brazil
Mailing Address:
P.O. Box 13
07180-900 Guarulhos
Sao Paulo, Brazil
Telephone: (55-11) 945-9811

Country
Covered: Brazil

Beijing Regional Office - China

Cummins Corporation
China World Tower, Suite 917
China World Trade Center
No. 1 Jian Guo Men Wai
Beijing 100004
People's Republic of China
Telephone: (86-1) 505-4209/10

Countries
Covered: China
Mongolia

Bogota Regional Office - Colombia

Cummins Engine Co. de Colombia S.A.
Carrera 11A No. 90-15 Of. 601/602
Bogota, D.E., Colombia
Telephone: (57-1) 610-4849
Mailing Address:
Apartado Aereo 90988
Bogota D.E., Colombia

Countries
Covered: Argentina Ecuador
Bolivia Paraguay
Chile Peru
Colombia Uruguay

Lyon Regional Office - France

Cummins Diesel Sales Corporation
39, rue Ampere - Zone Industrielle
69680 Chassieu
France
Telephone: (33) 72-22-92-72

Countries
Covered: Algeria Martinique
France New Caledonia
Guadeloupe Reunion
Guyana

Gross-Gerau Regional Office - Germany

Cummins Diesel Deutschland GmbH
Odenwaldstr. 23
D-6080 Gross-Gerau
Germany
Telephone: (49-6152) 174-0

Countries
Covered: Albania Poland
Bulgaria Romania
*Czech Southeastern
Republic Europe
Germany Slovika
Luxembourg

*Marine Only

Hong Kong Regional Office - Hong Kong

Cummins Engine H.K. Ltd.
Unison Industrial Centre
15th Floor, Units C & D
27-31 Au Pui Wan Street
P. O. Box 840 Shatin
Fo Tan, Shatin, N.T.
Hong Kong
Telephone: (852) 606-5678

Country
Covered: Hong Kong

Pune Kirloskar Regional Office - India

Kirloskar Cummins Limited
Kothrud
Pune - 411 029, India
Telephone: (91-212) 33-0240, 33-5435, 33-1105

Countries
Covered: Bhutan
India
Nepal

Milan Regional Office - Italy

Cummins Diesel Italia S.P.A.
Piazza Locatelli 8
Zona Industriale
20098 San Giuliano Milanese
Milan, Italy
Telephone: (39-2) 982-81235/6/7

Country
Covered: Italy

North Asia Regional Office - Japan

Cummins Diesel Sales Corporation
1-12-10 Shintomi
Chuo-ku, Tokyo 104
Japan
Telephone: (81-3) 3555-3131/2/3/4/5

Country
Covered: Japan

Seoul Regional Office - Korea

Cummins Korea Ltd.
5th Floor, Hye Sung Building
35-26 Sam Sung Dong, Kang Nam Ku
Seoul, South Korea
Telephone: (82-2) 516-0431/2/3, 517-3370/1

Country
Covered: South Korea

Cummsa Regional Office - Mexico

Cummins, S.A. de C.V.
Arquimedes No. 209
Col. Polanco
11560 Mexico, D.F.
Mexico
Telephone: (52-5) 254-3822/3783/3622
Mailing/Shipping Address:
Gonzalez de Castilla Inc.
P.O. Box 1391
4605 Modern Lane
Modern Industrial Park
Laredo, TX 78040
Telephone: (512) 722-5207

Country
Covered: Mexico

Moscow Regional Office - Russia

Cummins Engine Co., Inc.
Park Place
Office E708
Leninsky Prospect 113
Russia 11798
Telephone: (7-502) 256-5122 or 256-5123

Countries
Covered: Armenia Lithuania
Azerbaijan Moldova
Bolarus Russia
Estonia Tadjhikstan
Georgia Turkmenistan
Kirghizia Ukraina
Latvia Uzbekistan

South And East Asia Area Office - Singapore

Cummins Diesel Sales Corporation
8 Tanjong Penjuru
Jurong Industrial Estate
Singapore 2260
Telephone: (65) 265-0155

Countries
Covered: Bangladesh Malaysia
Brunei Mongolia
Burma/Mynamar Philippines
Cambodia Singapore
China Sri Lanka
Hong Kong Taiwan
Indonesia Thailand
Laos Vietnam
Macau

Taipei Regional Office - Taiwan

Cummins Corporation - Taiwan
12th Floor, No. 149
Min-Sheng E. Road
Section 2
Taipei, Taiwan
R.O.C. 104
Telephone: (886-2) 515-0891

Country
Covered: Taiwan

Turkey and Iran Regional Office - Turkey

Cummins Corporation
Istanbul Office
Buyukdere Cad.
Beytem Han, Kat 11
Sisli 80220
Istanbul
Telephone: (90-1) 246-2575/2775/2545

Countries
Covered: Iran
Turkey

**Middle East/Africa Regional Office -
Daventry (U.K.)**

Cummins Engine Company Ltd.
Royal Oak Way South
Daventry, Northants NN11 5NU
England
Telephone: (44-1327) 76000

Countries Covered:

	MIDEAST	
Afghanistan	Jordan	Saudi Arabia
Bahrain	Kuwait	Sudan
Cyprus	Lebanon	Syria
Djibouti	Oman	U.A.E.
Egypt	Pakistan	Yemen
Iraq	Qatar	
	NORTH/WEST AFRICA	
Benin	Gabon	Mauritania
Burkina-Paso	Gambia	Morocco
Cameroon	Ghana	Niger
Cape Verde	Guinea	Nigeria
Central African Republic	Guinea- Bissau	Sao Tome & Principe
Chad	Liberia	Senegal
Cote d'Ivoire	Libya	Siera Leone
Equatorial Guinea	Mali	Togo
	Malta	Tunisia
	SOUTH AFRICA	
Botswana	Namibia	Swaziland
Lesotho	South Africa	

New Malden Regional Office - U.K.

Cummins Engine Company Limited
46-50 Coombe Road
New Malden
Surrey KT3 4QL
England
Telephone: (44-81) 949-6171

Countries

Covered: Ireland
United Kingdom

**Latin America Regional Office - Miramar
(U.S.A.)**

Cummins Americas, Inc.
Miramar Park of Commerce
3450 Executive Way
Miramar, FL 33025
Telephone: (305) 431-5511

Countries

Covered: Argentina Guatemala
Bolivia Honduras
Chile Nicaragua
Colombia Panama
Costa Rica Paraguay
Dominican Republic Peru
El Salvador Uruguay
Ecuador Venezuela

Caracas Regional Office - Venezuela

Cummins Engine Company
Oficina de Delegado
Torre La Primera, Oficina 5-D
Av. Francisco de Miranda
Chacao, Caracas 1060

Mailing Address:

Cummins Engine Company M-227
c/o Jet Cargo International
P.O. Box 020010
Miami, FL 33102-0010 U.S.A.
Telephone: (58-2) 32-0563, 32-718

Countries

Covered: Costa Rica Honduras
Dominican Republic Nicaragua
El Salvador Panama
Guatemala Venezuela

**East/Southern Africa Regional Office - Harare,
Zimbabwe**

Cummins Zimbabwe (Private) Limited
72 Birmingham Road
Southerton
Harare, Zimbabwe

Mailing Address:

P.O. Box ST363
Southerton
Harare, Zimbabwe
Telephone: (263-4) 67645, 60553, 69220

Countries

Covered: Angola Reunion
Burundi Rwanda
Comoros Island Seychelles
Congo Somalia
Ethiopia Tanzania
Kenya Uganda
Madagascar Zaire
Malawi Zambia
Mauritius Zimbabwe
Mozambique

Distributors - International

ABU DHABI

- See United Arab Emirates

AFGHANISTAN

- See Middle East Regional Office

ALBANIA

- See Germany Regional Office -
Gross-Gerau

ALGERIA

Algiers

Cummins Corporation
Bureau de Liaison
38, Lotissement Benachour Abdelkader
Cheraga
43200 Wilaya de Tipasa
Algeria
Telephone: (213) 237-43-26

AMERICAN SAMOA

- See South Pacific Regional Office

ANDORRA

- See European Regional Office -
Mechelen

ANTIGUA

Miami (Office In U.S.A.)
Cummins Southeastern Power, Inc.
9900 N.W. 77 Court
Hialeah Gardens, FL 33016
Telephone: (305) 821-4200

ARGENTINA

Buenos Aires

Distribuidora Cummins, S.A.
(DICUMAR)
Av. Del Libertador 602 Piso 5
Buenos Aires, Argentina
Telephone: (54-1)814-1895/1395/1393

ARUBA, ISLAND OF

- See Netherlands Antilles

AUSTRIA

Neudoerfl

Cummins Diesel Motorenvertriebsges
m.b.H. Trenner & Co.
Bickfordstr. 25
A-7201 Neudoerfl
Austria
Telephone: (43-2622) 77418/77625

BAHAMAS

Miami (Office in U.S.A.)

Cummins Southeastern Power, Inc.
9900 N.W. 77 Court
Hialeah Gardens, FL 33016
Telephone: (305) 821-4200

BAHRAIN

Bahrain

Yusuf Bin Ahmed Kanoo W.L.L.
P.O. Box 45, Manama
Bahrain
Telephone: (973) 400414/400506

BALEARIC ISLANDS

Madrid (Office in Spain)

Cummins Ventas y Servicio, S.A.
Torrelaguna, 56
28027 Madrid, Spain
Telephone: (34-91) 367-2000
376-2404

BANGLADESH

Dhaka

Equipment & Engineering Co., Ltd.
G.P.O. Box 2339
Dhaka 1000, Bangladesh
Location:
56, Dilkusha Commercial Area
2nd Floor/Eastern Block
Telephone: (880-2) 234357, 234060

BARBADOS

Miami (Office in U.S.A.)

Cummins Southeastern Power, Inc.
9900 N.W. 77 Court
Hialeah Gardens, FL 33016
Telephone: (305) 821-4200

BELGIUM

Brussels

Cummins Distributor
Belgium S.A.
623/629 Chaussee de Haecht
B-1030 Brussels, Belgium
Telephone: (24 hr.)
(32-2) 216-81-10

BELIZE

Tampa (Office in U.S.A.)

Cummins Southeastern Power, Inc.
5421 N. 59th Street
Tampa, FL 33610
Telephone: (813) 621-7202

BENIN

- See Togo

BERMUDA

Bronx (Office in U.S.A.)

Cummins Metropower, Inc.
890 Zerega Avenue
Bronx, NY 10473
Telephone: (718) 892-2400

BHUTAN

Pune (Office in India)

Cummins Diesel Sales &
Service (India) Ltd.
35A/1/2, Erandawana
Pune - 411 038, India
(State of Maharashtra) India
Telephone: (91-212) 331234/331554/
331635/330066/
330166/330356/
31703

BOLIVIA

La Paz

Machinery & Auto Service
Casilla 4042
La Paz, Bolivia
Location:
Av. 20 de Octubre Esq.
Rosendo Gutierrez
Telephone: (591-2) 379650, 366394

BONAIRE, ISLAND OF

- See Netherlands Antilles

BOTSWANA

- See East and Southern Africa Re-
gional Office - Harare

BRAZIL

Ananindeua

Marcos Marcelino & Companhia
Ltda.
Rodovia BR-316, Km 9
67020-010 Ananindeua, Para,
Brazil
Telephone: (55-91) 235-4100/4132/
4143/4012

Belo Horizonte

Distribuidora Cummins
Minas S.A.
31950-640 Olhos D'Agua Norte
Belo Horizonte, MG
Brazil
Telephone: (55-31) 288-1344

Campo Grande

Distribuidora Cummins
Mato Grosso Ltda.
Rodovia BR 163 Km 01
79060-000 Campo Grande
Mato Grosso do Sul, Brazil
Telephone: (55-67) 787-1166

Curitiba

Distribuidora Cummins Parana S.A.
Rua Brasilio Itibere, 2195
80230 Curitiba, Parana
Brazil
Telephone: (55-41) 222-4036

Fortaleza

Distribuidora Cummins Diesel
Do Nordeste Ltda.
Av. da Abolicao, 3882,
Mucuripe
60165-081 Fortaleza, Ceara
Brazil
Telephone: (55-85) 263-1212

Goianian

Distribuidora de Motores Cummins
Centro Oeste Ltda.
Av. Caiapo 777 - Setor Sta. Genoveva
74672-400 Goiania, Goias
Brazil
Telephone: (55-62) 207-1010

Manaus

Distribuidora Cummins
Amazonas Ltda.
Estrada da Ponta Negra, 6080 - Sao
Jorge
69037 Manaus, Amazonas,
Brazil
Telephone: (55-92) 656-5444

Porto Alegre

Distribuidora Cummins
Meridional S.A.
Rua Dona Alzira, 98, Sarandi
91110-010 Porto Alegre,
Rio Grande do Sul, Brazil
Telephone: (55-51) 340-8222

Rio de Janeiro

Distribuidora Cummins
Leste Ltda.
Rua Sariema, 138-Olaria
21030-550 Rio de Janeiro,
Rio de Janeiro, Brazil
Telephone: (55-21) 290-7899

Sao Paulo

Companhia Distribuidora
de Motores Cummins
Rua Martin Burchard, 291 - Bras
03043-020 Sao Paulo,
Sao Paulo, Brazil
Telephone: (55-11) 270-2311

BRITISH VIRGIN ISLANDS

- See Puerto Rico

BRUNEI

- See Malaysia

BURKINA - FASO

- See North/West Africa Regional
Office - Daventry

BULGARIA

- See Germany Regional Office - Gross-
Gerau

BURMA

Kuala Lumpur (Office In Malaysia)

Contact: Scott &
English (M) Sdn Bhd
P.O. Box 10324
50710 Kuala Lumpur
West Malaysia
Location:
16 Jalan Chan Sow Lin
55200 Kuala Lumpur
West Malaysia
Telephone: (60-3) 2211033

BURUNDI

Brussels (Office in Belgium)

Bia, S.A.
Rameistraat, 123
B-3090 - Overijse, Belgium
Telephone: (32-2) 6892811

CAMBODIA

- See South & East Asia Regional Office
- Singapore

CANARY ISLANDS

Madrid (Office in Spain)

Cummins Ventas y
Servicio, S.A.
Torrelauna, 56
28027 Madrid, Spain
Telephone: (34-91) 3672000/3672404

CAPE VERDE

- See North/West Africa Regional Office
- Daventry

CENTRAL AFRICAN REPUBLIC

- See North/West Africa Regional Office
- Daventry

CEYLON

- See Sri Lanka

CHAD

- See North/West Africa Regional Office
- Daventry

CHILE

Santiago

Distribuidora Cummins Diesel
S.A.C.I.
Casilla Postal 1230
Calle Bulnes 1203
Santiago, Chile
Corporate Office:
Av. Providencia 2653, Office 1901
Santiago, Chile
Telephone: (56-2) 698-2113/4/5,
697-3566/7/8,
697-2709

CHINA, PEOPLE'S REPUBLIC

- See China Regional Office - Beijing

COLOMBIA

Barranquilla

Cummins de Colombia S.A.
Apartado Aereo 5347
Barranquilla, Colombia
Location: Calle 30, No. 19 - 21
Telephone: (57-58) 40-02-06/40-13-46

Bogota

Cummins Colombiana Ltda.
Apartado Aereo No. 7431
Bogota, D.E. Colombia
Location:
Av. Americas X Carrera
42C No. 19-45
Telephone: (57-1) 244-5688/5882

Bucaramanga

Cummins API, Ltda.
Apartado Aereo 352
Bucaramanga, Colombia
Location:
Autopista a Giron, Km 7
Telephone: (57-76) 468060

Cali

Distribuidora Cummins del Valle, Ltda.
Apartado Aereo No. 6398
Cali, Colombia
Location:
Av. 3a. # 39-35 - Vipasa
Telephone: (57-3) 65-4343

Medellin

Equipos Tecnicos Ltda.
Apartado Aereo No. 2046
Medellin, Colombia
Location: Carrera 52 No. 10-184
Telephone: (57-4) 255-4200

Pereira

Equipos Tecnicos Ltda. C.Q.R.
Apartado Aereo No. 1240
Pereira, Colombia
Location: Carrera 8a. No. 45-39
Telephone: (57-63) 366341

COMOROS

- See East and Southern Africa Re-
gional Office - Harare

CONGO, PEOPLE'S REPUBLIC

Brussels (Office in Belgium)

Bia, S.A.
Rameistraat, 123
B-3090
Overijse, Belgium
Telephone: (32-2) 6892811

CORSICA

- See France

COSTA RICA

San Jose

Servicios Unidos, S.A.
P.O. Box 559
San Jose, Costa Rica
Location:
100 metros al este de
Excelsior Antiguo
Curridabat, San Jose
Telephone Office: (506) 53-93-93
Telephone Service Shop:
(506) 26-00-76

CUBA

Miami (Office in U.S.A.)

Cummins Southeastern Power, Inc.
9900 N.W. 77 Court
Hialeah Gardens, FL 33016
Telephone: (305) 821-4200

CYPRUS

Nicosia

Alexander Dimitriou & Sons Ltd.
P.O. Box 1932
Nicosia, Cyprus
Location:
4 Salamis Avenue
Telephone: (357-2) 349450

CZECH REPUBLIC

- See European Regional Office -
Mechelen

DENMARK

Glostrup

Preben Lange Industrimaskiner A/S
Post Box 166
2605 Broendby, Denmark
Location:
Midtager 22
Telephone: (45-43) 96-21-61

DJIBOUTI

- See Middle East Regional Office -
Daventry

DOMINICA

Miami (Office in U.S.A.)

Cummins Southeastern Power, Inc.
9900 N.W. 77 Court
Hialeah Gardens, FL 33016
Telephone: (305) 821-4200

DOMINICAN REPUBLIC

Santo Domingo

Argico C. Por A.
P.O. Box 292-2 Feria
Santo Domingo
Dominican Republic, ZP-6
Location:
Calle Jose A. Soler
No. 3, ESQ.
Avenida Lope de Vega
Telephone: (809) 562-6281

DUBAI

- See United Arab Emirates

ECUADOR

Guayaquil

Motores Cummins (MOTCUM) S.A.
P.O. Box 1062
Guayaquil, Ecuador
Location:
Avenida Carlos Julio
Arosemena Km. 4
Telephone: (593-4) 203995/201177

Quito

Rectificadora Botar S.A.
P.O. Box 17-01-3344
Quito, Ecuador
Location:
Av. 10 de Agosto No. 5980
Telephone: (593-2) 465-176/177/
178/195/197

EGYPT

Cairo

ADAT
P.O. Box 1572
Cairo, Egypt
Sales and Service Location:
25, Pyramid Road
Giza, Cairo, Egypt
Telephone: (20-2) 384-6607/384-6609
385-4001/2/4/5/6/8/9

EL SALVADOR

San Salvador

Salvador Machinery
Company, S.A. de C.V.
P.O. Box 125
San Salvador, El Salvador
Location:
Blvd. Ejercito Nacional
Telephone: (503) 711022, 228388

ENGLAND

- See United Kingdom

EQUATORIAL GUINEA

- See North/West Africa Regional Office
- Daventry

ESTONIA

- See Moscow Regional Office - Moscow

FAROE ISLANDS

Wellingborough (Office in United Kingdom)

Cummins Diesel
Denington Industrial Estate
Wellingborough
Northants NN8 2QH,
England
Telephone: (44-933) 276231

FERNANDO PO

- See Spain

FIJI

- See Cummins Diesel Sales & Service
New Zealand Ltd.

FINLAND

Helsinki

Machinery OY
P.O. Box 56
SF 00511 Helsinki, Finland
Location:
Teollisuuskatu 29
Telephone: Int: (358-9) 77221

FRANCE

Lyon

Cummins Diesel
Sales Corporation
39, rue Ampere Z.I.
69680 Chassieu, France
Telephone: (33) 72-22-92-72
Parts and Service Telephone:
(33) 72-22-92-69

GABON

- See North/West Africa Regional Office
- Daventry

GAMBIA

Senegal (Matforce)

GEORGIA

- See Moscow Regional Office - Moscow

GERMANY

Gross-Gerau

Cummins Diesel Deutschland GmbH
P.O. Box 1134
D-6080 Gross-Gerau,
Germany
Location: Odenwaldstr. 23
Telephone: (49-6152) 174-0

GHANA

Accra

Leyland DAF (Ghana) Ltd.
P.O. Box 2969
Accra, Ghana
Location:
39/40 Ring Road South
Industrial Estate
Telephone: (233-21) 22-88-06

GREECE

Athens

Eliopoulos Brothers Ltd.
P.O.B. 51528
14 Km. National Rd.
Athens-Lamia
14510 Kifissia, Greece
Telephone: (30-1) 6202401/6202066/
6201955

GREENLAND

- See Denmark

GRENADA

Miami (Office in U.S.A.)

Cummins Southeastern Power, Inc.
9900 N.W. 77 Court
Hialeah Gardens, FL 33016
Telephone: (305) 821-4200

GUADELOUPE

Miami (Office in U.S.A.)

Cummins Southeastern Power, Inc.
9900 N.W. 77 Court
Hialeah Gardens, FL 33016
Telephone: (305) 821-4200

GUAM

Barrigada

Mid-Pac Far East, Inc.
Airport Industrial Park
825 Tiyan Parkway
Barrigada, Guam 96921
Telephone: (671) 632-5160

GUATEMALA

Guatemala City

Maquinaria y Equipos, S.A.
P.O. Box 2304
Guatemala City, Guatemala
Location:
Carretera Amatitlan
Km 12 zona 12
Telephone: (502-2) 773334/719

GUINEA BISSAU

- See North/West Africa Regional Office
- Daventry

GUYANA

Miami (Office in U.S.A.)

Cummins Southeastern Power, Inc.
9900 N.W. 77 Court
Hialeah Gardens, FL 33016
Telephone: (305) 821-4200

GUYANA, FRENCH

Miami (Office in U.S.A.)

Cummins Southeastern Power, Inc.
9900 N.W. 77 Court
Hialeah Gardens, FL 33016
Telephone: (305) 821-4200

HAITI

Miami (Office in U.S.A.)

Cummins Southeastern Power, Inc.
9900 N.W. 77 Court
Hialeah Gardens, FL 33016
Telephone: (305) 821-4200

HOLLAND

- See Netherlands

HONDURAS

Tegucigalpa

Comercial Laeisz
Honduras, S.A.
P.O. Box 1022
Tegucigalpa, D.C., Honduras
Location:

Zona La Burrera,
Blvd. Toncontin
Frente a Gasolinera Esso.
Telephone: (504) 333570/335615

HONG KONG

Kowloon

Cummins Engine H. K. Ltd.
P.O. Box 840 Shatin
N.T., Hong Kong
Location:

Unison Industrial Centre
15th Floor, Units C & D
27-31 Au Pui Wan Street
Fo Tan, Shatin, Hong Kong
Telephone: (852) 606-5678

INDIA

Pune

Cummins Diesel Sales &
Service (India) Ltd.
35A/1/2, Erandawana
Pune - 411 038, (State of Maharashtra)
India
Telephone: (91-212) 331234, 331554,
331635, 330066,
330166, 330356,
331703

Bombay

Cummins Diesel Sales &
Service (I) Ltd.
298, Perin Nariman Street, Fort,
Bombay 400001, India
Telephone: (91-22) 2863566/2862247

Calcutta

Cummins Diesel Sales &
Service (I) Ltd.
94, Tivoli Court, I/C Ballygunge
Circular Road
Calcutta 700 019 (West Bengal), India
Telephone: (91-33) 2478065/2470481/
2470774

New Delhi

Cummins Diesel Sales &
Service (I) Ltd.
Flat No. 307, Meghdoot Building
94 Nehru Place
New Delhi 110 019, India
Telephone: (91-11) 6431051/6445756/
6452817

Raipur

Cummins Diesel Sales &
Service (I) Ltd.
Plot No. 15, Jalashay Marg
Choube Colony
Raipur 492 001 (Madhya Pradesh),
India
Telephone: (91-771) 24994/23157/29498

Ranchi

Cummins Diesel Sales &
Service (I) Ltd.
'Shanti Kunj' C-202, Vidyalaya Marg
Road No. 1, Ashoknagar
Ranchi 834 002 (Bihar)
India
Telephone: (91-651) 301948/303623

INDONESIA

Jakarta

P.T. Alltrak 1978
P.O. Box 64/KBYL
Jakarta Selatan 12330, Indonesia
Location:
J1. R.S.C. Veteran No. 4
Bintaro, Rempoa
Telephone: (62-21) 736-1978/736-3302

IRAN

Tehran

Technical Service Development
Company
P.O. Box 13445/741
No. 152 Sohravardi Crossing
Dr. Beheshti Avenue
Tehran, Iran
Telephone:
Head Office: (98-21) 846666, 851021-7
Work Shop: (98-21) 995021-2/993240

IRAQ

- See Middle East Regional Office -
Daventry

IRELAND

Wellingborough (Office in England)

Cummins Diesel
Denington Estate
Wellingborough
Northants NN8 2QH, England
Telephone: (44-933) 276231

ISRAEL

Tel Aviv

Israel Engines &
Trailers Co. Ltd.
Levinson Brothers Engineers
P. O. Box 390
33 Hahashmal Street
Tel Aviv, Israel 61003
Telephone: (972-3) 5607671

ITALY

Milan

Cummins Diesel Italia S.p.A.
Piazza Locatelli, 8
Zona Industriale Sesto Ulteriano
20098 S. Giuliano
Milanese (Milan), Italy
Telephone: (39-2) 9828-1235/6/7

IVORY COAST

- See Cote d' Ivoire

JAMAICA

Miami (Office in U.S.A.)

Cummins Southeastern Power, Inc.
9900 N.W. 77 Court
Hialeah Gardens, FL 33016
Telephone: (305) 821-4200

JAPAN

Tokyo

Cummins Diesel (Japan) Ltd.
1-12-10-Shintomi
Chuo-ku, Tokyo 104
Japan
Telephone: (81-3) 3555-8511

JORDAN

Amman

S.E.T.I. Jordan Limited
P.O. Box 8053
Amman, Jordan
Telephone: (962-6) 621867/621884

KENYA

Nairobi

Werrot & Company Limited
P.O. Box 41216
Nairobi, Kenya
Location:
Lusaka Road
Telephone: (254-150) 20316

KOREA, SOUTH

Seoul

Hwa Chang Trading Co., Ltd.
Central P.O. Box No. 216
Seoul, South Korea
Location:
143-11 Doksan-dong, Kuro-ku
Telephone: (82-2) 854-0071/2/3/4/5,
869-1411/2/3

KUWAIT

Kuwait

General Transportation &
Equipment Co.
(Sales Department)
P.O. Box 1096
13011 Safat, Kuwait
Location:
Shuwaikh Behind
Canada Dry Factory
Telephone: (965) 4833380/1/2

Kuwait

General Transportation &
Equipment Co.
(Service Department)
East Ahmadi Area
13011 Safat, Kuwait
Telephone: (965) 3981577

LAOS

- See South and East Asia Regional Of-
fice - Singapore

LATVIA

- See Moscow Regional Office - Moscow

LEBANON

Beirut

S.E.T.I. Charles Keller
S.A.L.
B.P. 16-6726
Beirut, Lebanon
Location:
Corniche du Fleuve
Telephone: (961-1) 425040/41

LESOTHO

- See South Africa

LIBYA

- See North/West Africa Regional Office
- Davenport

LIECHTENSTEIN

- See Switzerland

LUXEMBOURG

Gross-Gerau (Office in Germany)

Cummins Diesel Deutschland GmbH
P.O. Box 11 34
Odenwaldstrasse 23
D-6080 Gross-Gerau, Germany
Telephone: (49-6152) 174-0

MACAU

- See Hong Kong

MADAGASCAR

- See East and Southern Africa Re-
gional Office - Harare

MADEIRA ISLANDS

- See Portugal

MALAYSIA

Kuala Lumpur

Cummins Diesel Sales & Service
Div. of Scott & English
(M) Sdn. Bhd.
P.O. Box 10324
50710 Kuala Lumpur, West Malaysia
Location:
16 Jalan Chan Sow Lin
55200 Kuala Lumpur
Telephone: (60-3) 2211033

MALI

- See Senegal (Matforce)

MALTA

Valletta

Plant & Equipment Ltd.
Regency House
254, Republic Street
Valletta, Malta
Telephone: (356) 23-26-20, 23-33-43,
23-16-23, 24-75-17

MARTINIQUE

Miami (Office in U.S.A.)

Cummins Southeastern Power, Inc.
9900 N.W. 77 Court
Hialeah Gardens, FL 33016
Telephone: (305) 821-4200

MEXICO

Guadalajara

Cummins Del Occidente, S.A.
Lazaro Cardenas No. 2950
Fracc. Alamo Industrial
45560 Guadalajara, Jal. Mexico
Telephone: (52-3) 670-93-06, 670-53-38,
670-63-61, 670-62-33

Monterrey

Tecnica Automotriz, S.A.
Av. Alfonso Royes
No. 3637 Nte.
Monterrey, Nuevo Leon, Mexico
Telephone: (52-83) 51-41-51, 51-46-56

Merida

Cummins Del Sureste, S.A. de C.V.
Av. Aviacion Civil No. 647
Esquina Calle 100
Col. Sambula
97259 Merida, Yucatan, Mexico
Telephone: (52-99) 24-11-55, 24-00-15

Puebla

Cummins de Oriente, S.A. de C.V.
Av. Reforma No. 2112,
Puebla, Pue. Mexico
Telephone: (52-22) 48-76-74, 48-76-75

Queretaro

Distribuidor Cummins Del Centro, S.A.
de C.V.
Blvd. Bernardo Quintana No. 518
Col. Arboledas
C.P. 76140 Queretaro, Qro., Mexico
Telephone: (52-42) 12-41-90, 12-58-90,
12-62-94, 14-04-16,
14-08-81, 14-15-91

Tlalnepantla

Distribuidor Cummins
Metropolitana, S.A. DE C.V.
Sor Juana Ines de la Cruz No. 555
54000 Tlalnepantla, Edo. de Mexico,
Mexico
Telephone: (52-5) 327-38-00, 390-64-37,
390-12-27

MOROCCO

Casablanca

Societe Auto-Hall, S.A.
44 Avenue Lalla Yacout
Casablanca, Morocco
Telephone: (212) 31-84-60, 31-70-52,
31-90-56, 31-70-44

MOZAMBIQUE

- See East and Southern Africa Regional Office - Harare

NAMIBIA (Southwest Africa)

Windhoek

Propower, Namibia
P.O. Box 3637, Windhoek 9000
Namibia (Southwest Africa)
Location:
7 Nasmyth Street
Southern Inudustria
Telephone: (264-61) 37693

NEPAL

Pune (Office in India)

Cummins Diesel Sales &
Service (India) Ltd.
35A/1/2, Erandawana
Pune, - 411 038, (State of Maharashtra)
India
Telephone: (91-212) 331234, 331554,
331635, 330066,
330166, 330356,
331703

NETHERLANDS

Dordrecht

Cummins Diesel Sales &
Service, b.v.
Galvanistraat 35
3316 GH Dordrecht
Netherlands
Telephone: (31-78) 18-12-00

NETHERLANDS ANTILLES

Miami (Office in U.S.A.)

Cummins Southeastern Power, Inc.
9900 N.W. 77 Court
Hialeah Gardens, FL 33016
Telephone: (305) 821-4200

NEW CALEDONIA

- See South Pacific Regional Office - Melbourne

NEW GUINEA

- See Papua New Guinea

NICARAGUA

Managua

F. Alf. Pellas & Cia.
Apartado Postal No. 46
Managua, Nicaragua
Location:
6a. Calle
30 y 31 Avs. N.O., Zona 5
Telephone: (505-2) 660616

NIGERIA

Lagos

SCOATRAC MOSEL
P.M.B. 21108
Ikeja, Lagos
Nigeria
Location:
Apapa-Oshodi Expressway
Isolo Industrial Estate,
Isolo
Telephone: (234-1) 52-15-39, 52-19-31,
52-46-70

Paris (Office in France)

SCOATRAC MOSEL
c/o SCOA
9 et 11 rue Robert de Flers
75740 Paris, Cedex 15
France
Telephone: (33-1) 40-58-48-48

NORTHERN IRELAND

- See United Kingdom

NORWAY

Oslo

Cummins Diesel Salg & Service A/S
P.O. 6288
Etterstad 0603, Oslo 6
Norway
Location:
Verkseler Furulunds vei 11
Telephone: (47) 22326110

OMAN

Ruwi

Universal Engineering
Services L.L.C.
P.O. Box 5688
Ruwi
Sultanate of Oman
Telephone: (968) 590830, 591304

PAKISTAN

Karachi

- See Middle East Regional Office - Daventry

PANAMA

Panama City

Grupo Tiesa, S.A.
Apartado Postal #55-0549
Partillo, Panama
Telephone: (507) 67-3866

PAPUA NEW GUINEA

Sydney (Office in Australia)

Cummins Diesel Sales & Service
P.O. Box 150
Cabramatta, 2166
New South Wales, Australia

PARAGUAY

Asuncion

Automotores y Maquinaria,
S.R.L.
Yegros y Fulgencio R. Moreno
P.O. Box 1160
Asuncion, Paraguay
Telephone: (595-21) 493111, 493115

PERU

Lima

Comercial Diesel
del Peru S.A.
P.O. Box 14-0234
Lima, Peru
Location:
Ave. V.R. Haya
de la Torre 2648
Lima 3, Peru
Telephone: (51-14) 74-3173/4374/
3144/2281

PHILIPPINES

EDSA

Power Systems, Inc. EDSA
P.O. Box 3241
Manila
Philippines 1501
Location:
79E. Delos Santos Ave.
Mandaluyong, Metro Manila
Telephone: (63-2) 791769, 791771,
5311945, 5315448,
5311934, 5312531,
53414513

POLAND

- See Germany Regional Office - Gross-Gerau

PORTUGAL

Lisbon

Electro Central
Vulcanizadora, Lda.
P.O. Box 3077
1302 Lisbon, Portugal
Location:
Rua Conselheiro
Martins de Carvalho
Lote 1480
1400 Lisboa (Restelo)
Telephone: (351-1) 3015361

QATAR

Doha

Jaidah Motors & Trading Co.
P.O. Box 150
Doha, Qatar (Arabian Gulf)
Telephone: (974) 810000

REUNION

- See Lyon Regional Office - Lyon

RIO DE ORO

- See Spain

ROMANIA

- See Germany Regional Office - Gross-Gerau

RUSSIA

- See Moscow Regional Office - Moscow

RWANDA

Brussels (Office in Belgium)

Bia, S.A.
Rameistraat, 123
B-3090 - Overijse, Belgium
Telephone: (32-2) 6892811

ST. LUCIA

Miami (Office in U.S.A.)

Cummins Southeastern Power, Inc.
9900 N.W. 77 Court
Hialeah Gardens, FL 33016
Telephone: (305) 821-4200

ST. VINCENT

Miami (Office in U.S.A.)

Cummins Southeastern Power, Inc.
9900 N.W. 77 Court
Hialeah Gardens, FL 33016
Telephone: (305) 821-4200

SAN MARINO

- See Italy

SAO TOME AND PRINCIPE

- See North/West Africa Regional Office
- Daventry

SAUDI ARABIA

Dammam

General Contracting Company
P.O. Box 5111
Dammam 31422, Saudi Arabia
Telephone: (966-3) 842-1216

SCOTLAND

- See United Kingdom

SENEGAL

Dakar

Matforce
B.P. 397
Dakar, Senegal
Location:
10 Avenue Faidherbe
Telephone: (221) 22-30-40

SEYCHELLES

- See East/Southern Africa Regional Office - Harare

SIERRA LEONE

- See North/West Africa Regional Office
- Daventry

SINGAPORE

Singapore

Applied Diesel Sales & Service Pte Ltd
8 Tanjong Penjuru
Jurong Industrial Estate
Singapore 2260
Telephone: (65) 261-3555

SLOVAKIA

- See European Regional Office -
Mechelen

SOLOMON ISLANDS

- See South Pacific Regional Office -
Melbourne

SOMALIA

- See East and Southern Africa Re-
gional Office - Harare

SOUTH AFRICA

Johannesburg

Propower Pty. Ltd.
Private Bag X4
Wendywood 2144
South Africa
Location:
13 Eastern Service Road
Kelvin 2054
Telephone: (27-11) 444-3225

SOUTHWEST AFRICA

- See Namibia

SPAIN

Madrid

Cummins Ventas y
Servicio S.A.
Torrelaguna, 56
28027 Madrid, Spain
Telephone: (34-91) 367-2000/3672404

SPANISH GUINEA

- See Spain

SRI LANKA

Colombo

Trade Promoters Ltd
P.O. Box 321
69, Walukarama Road
Colombo 3
Sri Lanka
Telephone: (94-1) 573927, 574651,
575005

SUDAN

Khartoum

Bittar Engineering Ltd.
P.O. Box 1011
Gambouria Street
Khartoum, Sudan
Telephone: (249-11) 70952, 71245,
70306

SURINAM

Miami (Office in U.S.A.)

Cummins Southeastern Power, Inc.
9900 N.W. 77 Court
Hialeah Gardens, FL 33016
Telephone: (305) 821-4200

SWAZILAND

- See South Africa

SWEDEN

Stockholm

SMA Maskin AB
Aggelundavagen 7
S-17562 Jarfalla
Sweden
Telephone: (46-8) 621-25-00

SWITZERLAND

Regensdorf

Robert Aebi AG
Riedthofstrasse 100
8105 Regensdorf
Switzerland
Telephone: (41-1) 842-5111

SYRIA

Damascus

Puzant Yacoubian & Sons
P.O. Box 3617
Damascus, Syria
Location:
Abou Baker El Saddik Street
Kafar Sousse Square
Telephone: (963-11) 231547/8/9

TAHITI, ISLAND OF

- See French Polynesia

TAIWAN

Taipei

Cummins Corporation - Taiwan Branch
12th Floor, No. 149
Min-Sheng E. Road, Sec. 2
Taipei, Taiwan
Telephone: (886-2) 515-0891

TANZANIA

Dar es Salaam

Riddoch Motors 1987 Ltd
P.O. Box 40040
Dar es Salaam
Tanzania
Location:
92 Kipawa-Pugu Road
Dar es Salaam
Telephone: (255-51) 44493, 41140

THAILAND

Bangkok

Diethelm & Company Ltd.
1696 New Petchburi Road
Bangkok 10310, Thailand
Telephone: (66-2) 254-4900

TOGO (and BENIN)

Lome

Togomat
B.P. 1641
Lome, Togo
Location:
Zone Industrielle CNPPME
Telephone: (228) 21-23-95

TONGA, ISLAND OF

- See South Pacific Regional Office -
Melbourne

TRINIDAD and TOBAGO

Miami (Office in U.S.A.)

Cummins Southeastern Power Inc.
9900 N.W. 77 Court
Hialeah Gardens, FL 33016
Telephone: (305) 821-4200

TURKEY

Istanbul

Hamamcioglu Muesseseleri
Ticaret T.A.S.
P.K. 136
80222 Sisli
Istanbul, Turkey
Location:
Buyukdere Caddesi, 13/A
80260 Sisli
Istanbul, Turkey
Telephone: (90-1) 231-3406, 234-5123

UKRAINA

- See Moscow Regional Office - Moscow

UNITED ARAB EMIRATES

Abu Dhabi

Technical Oilfield Supplies Centre
P.O. Box 2647
Abu Dhabi,
United Arab Emirates
Telephone: (971-2) 723863, 723298

UNITED KINGDOM

Wellingborough

Cummins Diesel
Denington Estate
Wellingborough
Northants NN8 2QH, England
Telephone: (44-933) 276231

UPPER VOLTA

- See Burkina - Faso

URUGUAY

Montevideo

Santaro S.A.
P.O. Box 379
Montevideo
Uruguay
Location:
Avenida Millan No. 2441
Telephone:(598-2) 293908

U.S.S.R.

- See Moscow Regional Office - Moscow

VATICAN CITY

- See Italy

VENEZUELA

Caracas

Sudimat
Apartado Postal 1322
Carmelitas
Caracas 1010
Venezuela
Location:
Final Avenida San Martin
Urb. la Quebradita
Caracas 1061
Telephone: (58-2) 442-6161/2647

VIETNAM

Hanoi

Diethelm & Co. Ltd. Engineering
Room No. 1, 2nd Floor
8 Trang Thi Street
Hanoi, Vietnam
Telephone: (84-4) 260-332, 244-394

Ho Chi Minh City

Diethelm & Co. Ltd. Engineering
3rd Floor, IBC Building
1 Me Linh Square
District 1
Ho Chi Minh City, Vietnam
Telephone: (84-8) 294-102, 294-103

WESTERN SAMOA

- See South Pacific Regional Office -
Melbourne

YEMEN ARAB REPUBLIC

Sana'a

Zubieri Trading Co.
P.O. Box 535
Sana'a, Yemen Arab Republic
Location:
Zubieri Street
Telephone: (967-1) 244400/79149

YEMEN, SOUTH

- See Middle East Regional Office -
Daventry

YUGOSLAVIA

- See Southeastern Europe

ZAIRE

Brussels (Office in Belgium)

N.V. Bia, S.A.
Rameistraat, 123
B-3090 - Overijse, Belgium
Telephone: (32-2) 689-28-11

ZAMBIA

Ndola

N.E.I. (Zambia) Ltd.
P.O. Box 71501
Ndola, Zambia
Telephone: (260-2) 610729

ZIMBABWE

Harare

Cummins Zimbabwe (Pvt) Ltd.
P.O. Box ST363
Southerton
Harare, Zimbabwe
Location:
72 Birmingham Road
Southerton, Harare
Telephones: (263-4) 67645, 69220

Section TS - Troubleshooting Symptoms

Section Contents

	Page
Procedures and Techniques.....	TS-1
Troubleshooting Symptoms Charts.....	TS-1
SYMPTOM: Air Compressor Air Pressure Rises Slowly.....	TS-2
SYMPTOM: Air Compressor Noise Excessive.....	TS-3
SYMPTOM: Air Compressor Pumping Excess Lubricating Oil Into Air System.....	TS-4
SYMPTOM: Air Compressor Will Not Maintain Adequate Air Pressure (Not Pumping Continuously).....	TS-5
SYMPTOM: Air Compressor Will Not Stop Pumping.....	TS-6
SYMPTOM: Alternator Not Charging or Insufficient Charging.....	TS-7
SYMPTOM: Coolant Loss — External.....	TS-8
SYMPTOM: Coolant Temperature Above Normal — Gradual Overheat.....	TS-9
SYMPTOM: Coolant Temperature Above Normal — Sudden Overheat.....	TS-11
SYMPTOM: Coolant Temperature Below Normal.....	TS-12
SYMPTOM: Crankcase Gases (Blowby) — Excessive.....	TS-13
SYMPTOM: Engine Acceleration and Response Poor.....	TS-14
SYMPTOM: Engine Cranks But Will Not Start (No Smoke From Exhaust).....	TS-15
SYMPTOM: Engine Decelerates Slowly.....	TS-16
SYMPTOM: Engine Difficult to Start or Will Not Start — Exhaust Smoke Present.....	TS-17
SYMPTOM: Engine Noise Excessive.....	TS-18
SYMPTOM: Engine Noise Excessive — Combustion Knocks.....	TS-19
SYMPTOM: Engine Power Output Low.....	TS-20
SYMPTOM: Engine Runs Rough at Idle.....	TS-22
SYMPTOM: Engine Runs Rough or Misfires.....	TS-23
SYMPTOM: Engine Shuts Off Unexpectedly or Dies During Deceleration.....	TS-24
SYMPTOM: Engine Speed Surges at Low Idle.....	TS-25
SYMPTOM: Engine Speed Surges (Other Than Low Idle).....	TS-26
SYMPTOM: Engine Starts But Will Not Keep Running.....	TS-27
SYMPTOM: Engine Vibration Excessive.....	TS-28
SYMPTOM: Engine Will Not Crank or Cranks Slowly (Air Starting Motor).....	TS-29
SYMPTOM: Engine Will Not Crank or Cranks Slowly (Electric Starting Motor).....	TS-30
SYMPTOM: Engine Will Not Reach Rated Speed When Loaded.....	TS-31
SYMPTOM: Engine Will Not Shut Off.....	TS-32
SYMPTOM: Fuel Consumption — Excessive.....	TS-33
SYMPTOM: Fuel in Coolant.....	TS-34
SYMPTOM: Fuel in the Lubricating Oil.....	TS-35
SYMPTOM: Lubricating Oil Consumption Excessive.....	TS-36
SYMPTOM: Lubricating Oil Contaminated.....	TS-37
SYMPTOM: Lubricating Oil Pressure High.....	TS-38
SYMPTOM: Lubricating Oil Pressure Low.....	TS-39
SYMPTOM: Lubricating Oil Sludge in the Engine Crankcase Excessive.....	TS-40
SYMPTOM: Lubricating Oil Temperature Above Specification.....	TS-41
SYMPTOM: Smoke, Black — Excessive.....	TS-42
SYMPTOM: Smoke, White — Excessive.....	TS-43
SYMPTOM: Turbocharger Boost Pressure Low.....	TS-44
SYMPTOM: Turbocharger Leaks — Engine Oil or Fuel.....	TS-45

THIS PAGE LEFT INTENTIONALLY BLANK.

Procedures and Techniques

A thorough analysis of the customer's complaint is the key to successful troubleshooting. The more information known about a complaint, the faster and easier the problem can be solved.

The Troubleshooting Symptom Charts are organized so that a problem can be located and corrected by doing the easiest and most logical things first. Complete all steps in the sequence shown from top to bottom.

It is **not** possible to include all the solutions to problems that can occur; however, these charts are designed to stimulate a thought process that will lead to the cause and correction of the problem.

Follow these basic troubleshooting steps:

- Get all the facts concerning the complaint
- Analyze the problem thoroughly
- Relate the symptoms to the basic engine systems and components
- Consider any recent maintenance or repair action that can relate to the complaint
- Double-check before beginning any disassembly
- Solve the problem by using the symptom charts and doing the easiest things first
- Determine the cause of the problem and make a thorough repair
- After repairs have been made, operate the engine to make sure the cause of the complaint has been corrected

Troubleshooting Symptoms Charts

Use the charts on the following pages of this section to aid in diagnosing specific engine symptoms. Read each row of blocks from top to bottom. Follow through the chart to identify the corrective action.



SYMPTOM: Air Compressor Air Pressure Rises Slowly

Cause

Correction

Intake Air Restriction to Air Compressor Excessive (Naturally Aspirated Air Compressors Only)

Replace air compressor air cleaner (if installed). Check engine intake air restriction if air compressor inlet is installed in intake piping between air cleaner and turbocharger.

OK



Air System Leaks

Check for air compressor gasket leaks. Check safety pressure valve leaks. Rating **must** be 150 psi. Check safety pressure valve location. Move if located near air compressor outlet. Refer to the manufacturer's instructions for other air system leaks.

OK



Carbon Buildup Excessive in the Air Discharge Line. Check Valve and/or Cylinder Head

To check carbon buildup, refer to Section 8. To replace air compressor head, refer to Master Repair Manual Holset Air Compressors, Bulletin No. 3666121. To replace discharge line, refer to equipment manufacturer.

OK



Contact a Cummins Authorized Repair Facility

SYMPTOM: Air Compressor Noise Excessive

Cause

Carbon Buildup Excessive in the Air Discharge Line. Check Valve and/or Cylinder Head

Correction

To check carbon buildup, refer to Air Compressor Carbon Buildup. To replace air compressor head, refer to Master Repair Manual Holset Air Compressors, Bulletin No. 3666121. To replace air discharge line(s), refer to the equipment manufacturer.

OK



Contact a Cummins Authorized Repair Facility



SYMPTOM: Air Compressor Pumping Excess Lubricating Oil Into Air System

Cause	Correction
Engine Oil Drain Intervals Excessive	Verify correct oil drain intervals. Refer to Section V.
OK ↓	
Intake Air Restriction to Air Compressor Excessive (Naturally Aspirated Air Compressor Only)	Replace air compressor air cleaner (if installed). Check engine intake restriction if air compressor inlet is installed in intake piping between air cleaner and turbocharger.
OK ↓	
Air Compressor Pumping Time Excessive	Check air compressor duty cycle. Refer to Installation Recommendations — Compressed Air Systems, Bulletin No. 3382886.
OK ↓	
Carbon Buildup Excessive in the Discharge Line, Check Valve and/or Cylinder Head	To check carbon buildup, refer to Air Compressor Carbon Buildup. To replace the air compressor head, refer to the Master Repair Manual Holset Air Compressors, Bulletin No. 3666121. To replace the air compressor discharge line(s), refer to the equipment manufacturer. Check the turbocharger for oil leadage. Refer to the M11 Shop Manual, Bulletin No. 3666075.
OK ↓	
Contact a Cummins Authorized Repair Facility	

SYMPTOM: Air Compressor Will Not Maintain Adequate Air Pressure (Not Pumping Continuously)

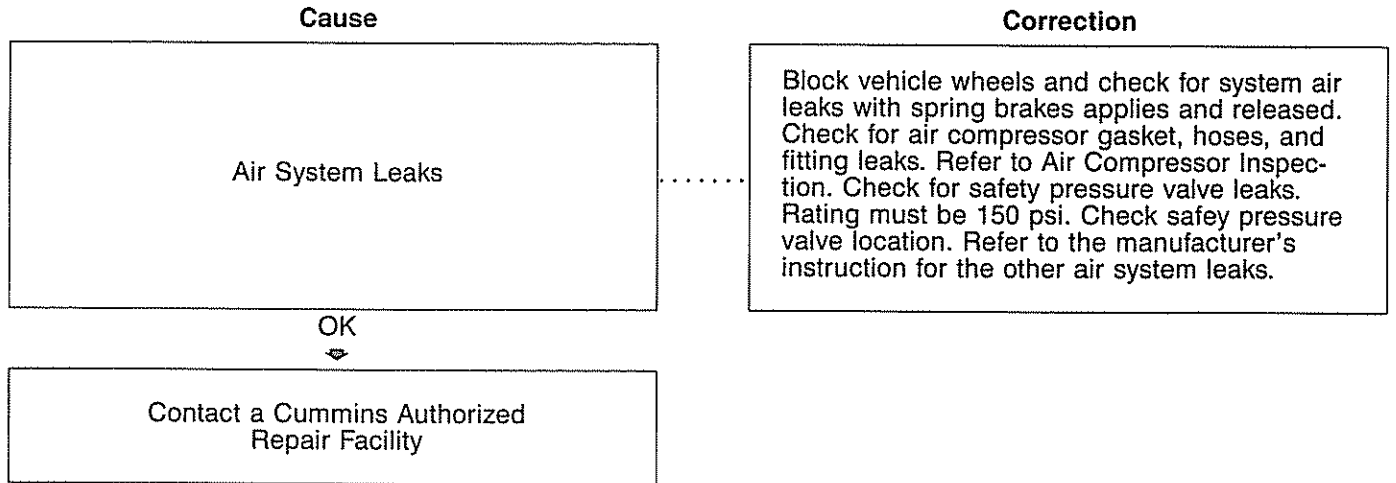

SYMPTOM: Air Compressor Will Not Stop Pumping

Cause

Correction

Air System Leaks

Block vehicle wheels and check for system air leaks with spring brakes applied and released. Check for air compressor gasket leaks. Check safety pressure valve for leaks. Rating must be 150 psi. Check safety pressure valve location. Move if located near air compressor outlet. Refer to the manufacturer's instructions for other air system leaks.

OK



Contact a Cummins Authorized Repair Facility

SYMPTOM: Alternator Not Charging or Insufficient Charging

Cause	Correction
Alternator Belt Loose	Check belt tension. Refer to Section A.
OK	
Battery Cable or Connection Loose. Broken or Corroded (Excessive Resistance)	Check battery cables and connections.
OK	
Batteries Failed	Check battery condition.
OK	
Alternator Pulley Loose on Shaft	Tighten pulley.
OK	
Contact a Cummins Authorized Repair Facility	



SYMPTOM: Coolant Loss — External

Cause	Correction
Coolant Level High	Check coolant level. Refer to the manufacturer for specifications.
OK ↓	
Coolant Leaks	Visually inspect hoses, hose clamps, coolant draincocks, expansion plugs, pipe plugs, fittings, radiator core, air compressor head gasket, cylinder head gasket, lubricating oil cooler, water pump seal, fuel heater, torque converter cooler, transmissions cooler, and so on. Tighten or replace if necessary.
OK ↓	
Incorrect or Malfunctioning Radiator Cap	Check the radiator pressure cap.
OK ↓	
Contact a Cummins Authorized Repair Facility	

SYMPTOM: Coolant Temperature Above Normal — Gradual Overheat

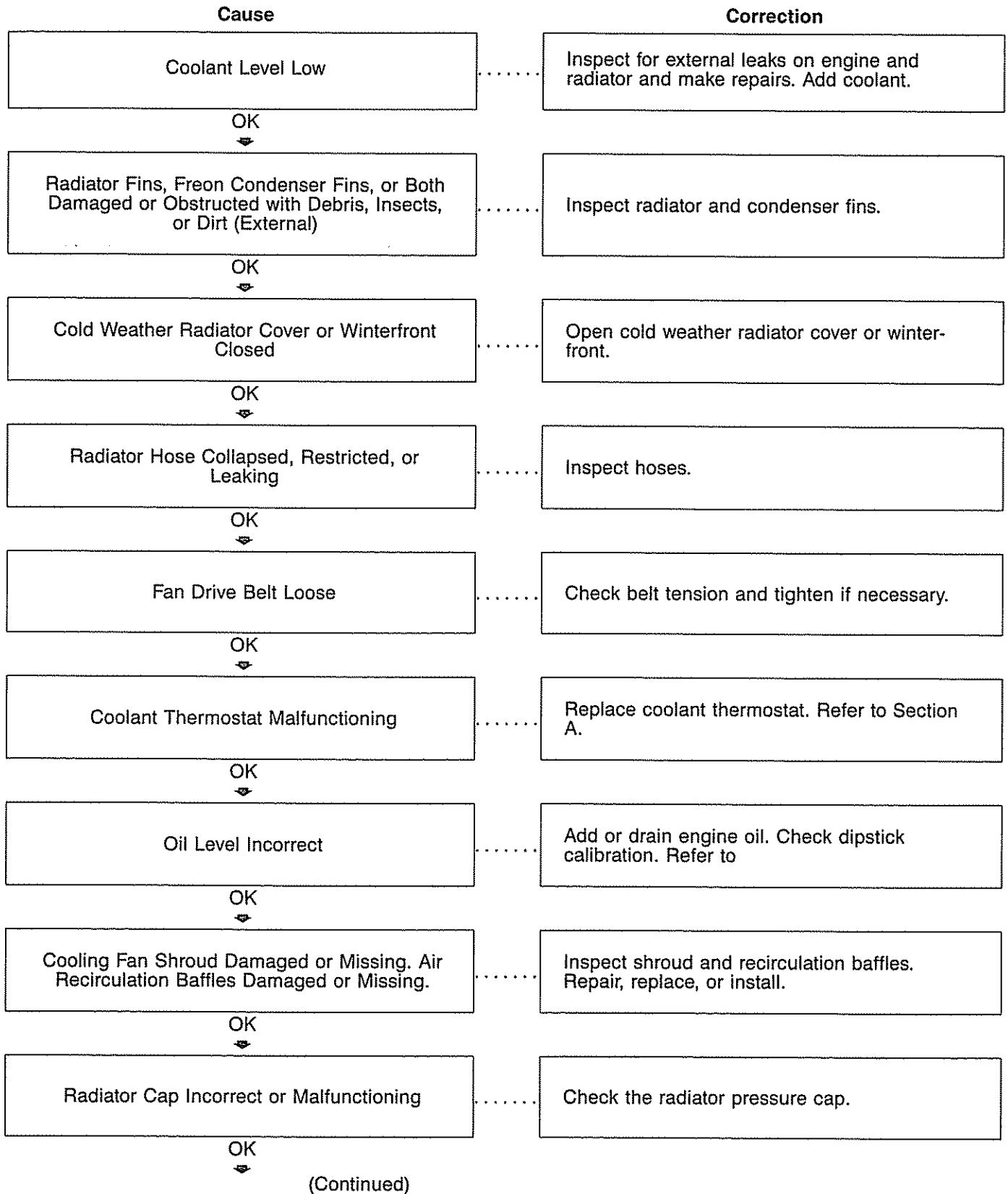

(Continued)

SYMPTOM: Coolant Temperature Above Normal — Gradual Overheat (Continued)

Cause

Overconcentration of Antifreeze or Supplemental Coolant Additives

OK



Contact a Cummins Authorized Repair Facility

Correction

Use correct concentration. Refer to Section V.

SYMPTOM: Coolant Temperature Above Normal — Sudden Overheat

Cause	Correction
Coolant Level Low	Inspect for external leaks on engine and radiator. Make repairs as necessary. Add coolant.
OK ↓	
Radiator Hose Collapsed, Restricted or Leaking	Inspect hoses.
OK ↓	
Fan Drive Belt Broken	Replace belt if broken. Refer to Section A.
OK ↓	
Radiator Cap Incorrect or Malfunctioning. Cap Rate Pressure Tool Low	Check the radiator pressure cap.
OK ↓	
Coolant Thermostat Damaged or Malfunctioning	Replace the coolant thermostat. Refer to Section A.
OK ↓	
Contact a Cummins Authorized Repair Facility	



SYMPTOM: Coolant Temperature Below Normal

Cause	Correction
Continuously Operating in Low Ambient Temperature	Refer to Cold Weather Operation, Bulletin No. 3387266-R.
OK ↓	
Radiator Shutters Stuck in Open Position or Opening Early	Check shutter operation. Repair or replace if necessary.
OK ↓	
Temperature Gauge and/or Sensor Malfunctioning	Test the gauge and sensor. Repair or replace if necessary.
OK ↓	
Contact a Cummins Authorized Repair Facility	

SYMPTOM: Crankcase Gases (Blowby) — Excessive

Cause

Correction

Crankcase Breather Vent Tube Restricted

..... Check breather tube restriction.

OK



Contact a Cummins Authorized
Repair Facility



SYMPTOM: Engine Acceleration and Response Poor

Cause

Correction

Vehicle Drive Train not Correctly Matched to Engine

Review specification of engine and drive train components.

OK

Contact a Cummins Authorized Repair Facility

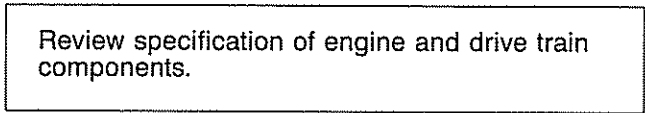
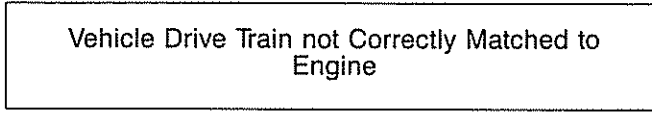

SYMPTOM: Engine Cranks But Will Not Start (No Smoke From Exhaust)

Cause	Correction
Fuel in Tank Too Low	Add fuel
OK ↓	
Starting Motor Rotation Incorrect	Check direction of crankshaft rotation. Replace starting motor.
OK ↓	
Shutoff Valve Closed	Use manual override. Repair fuel shutdown solenoid.
OK ↓	
Fuel Filter Plugged or Suction Line Broken or Plugged	Replace fuel filter and suction line.
OK ↓	
Fuel Connection Loose on Suction Side of Pump	Tighten all fuel fittings and connections from fuel tank to fuel pump.
OK ↓	
Return Fuel Lines Restricted or Plugged	Replace return fuel lines.
OK ↓	
Fuel Suction Stand Pipe in Fuel Tank Broken	To check, refer to the manufacturer's instructions.
OK ↓	
Contact a Cummins Authorized Repair Facility	

SYMPTOM: Engine Decelerates Slowly

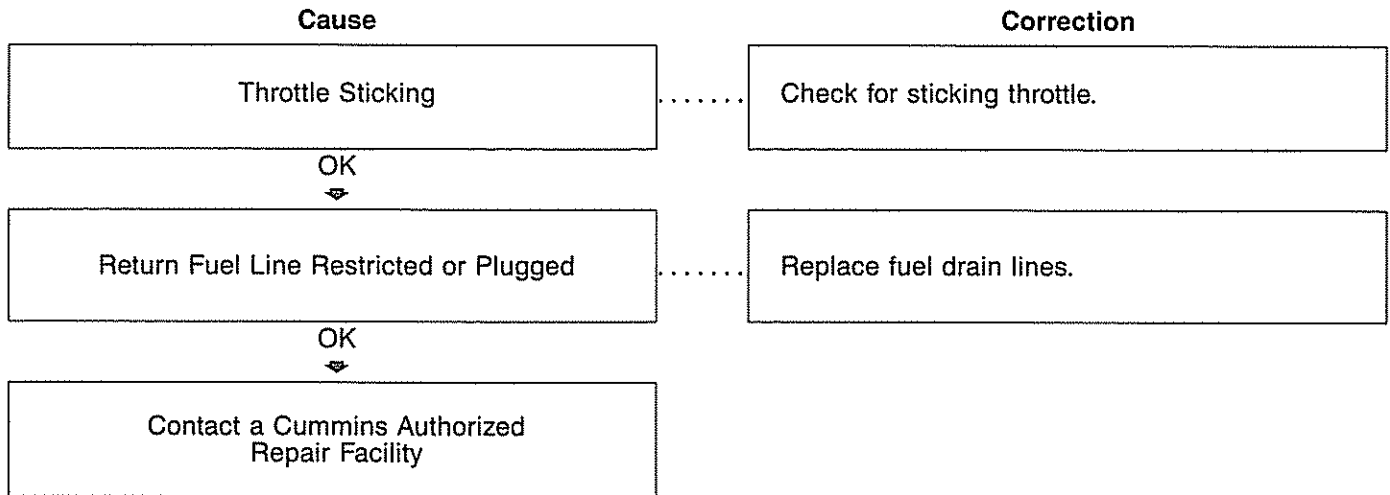

SYMPTOM: Engine Difficult to Start or Will Not Start — Exhaust Smoke Present

Cause	Correction
Battery Does Not Have at Least 7 Volts	Recharge battery
OK	
Starting Procedure Incorrect	Refer to the vehicle manufacturer's starting instructions.
OK	
Engine Cranking Speed Too Slow	Check engine cranking rpm. Refer to symptom chart Engine Will Not Crank or Cranks Slowly.
OK	
Engine Driven Units Engaged	Disengage engine driven units.
OK	
Fuel Shutoff Valve is Not Open	Check for loose wires and verify that the solenoid is functioning.
OK	
Starting Aid Needed for Cold Weather or Malfunction	Check and repair or replace cold starting aid if necessary.
OK	
Fuel Filter Plugged	Replace fuel filter.
OK	
Intake Air or Exhaust System Restricted	Check intake air and exhaust system for restrictions.
OK	
Contact a Cummins Authorized Repair Facility	

SYMPTOM: Engine Noise Excessive

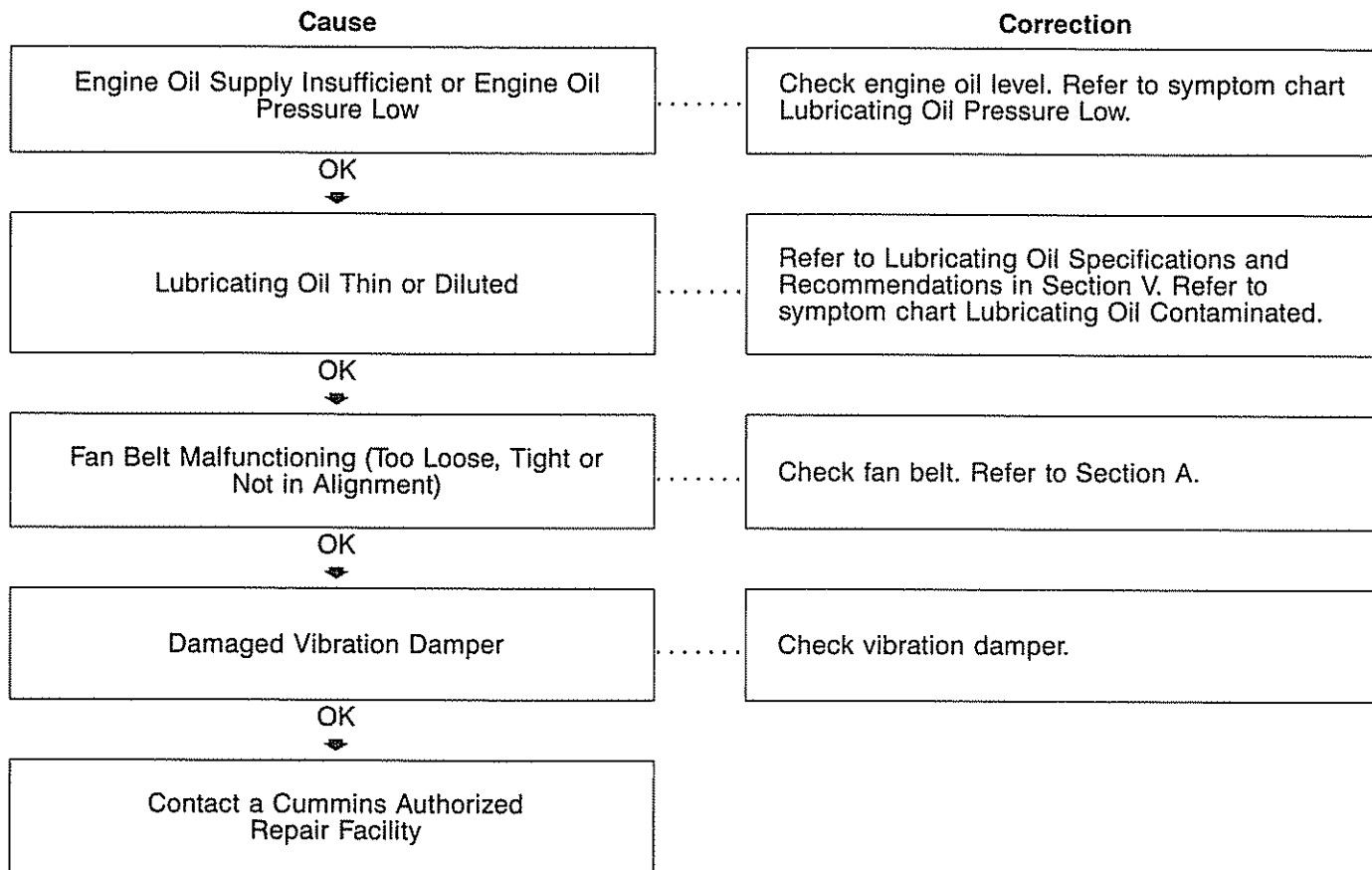

SYMPTOM: Engine Noise Excessive — Combustion Knocks

Cause	Correction
Ambient Air Temperature Too Low	Check winterfront and under hood air.
OK ↓	
Ether Starting Aid Malfunctioning	Repair or replace ether starting aids.
OK ↓	
Fuel Quality Poor	Verify by operating from a temporary tank with good fuel. Clean and flush the fuel supply tanks.
OK ↓	
Contact a Cummins Authorized Repair Facility	



SYMPTOM: Engine Power Output Low

Cause	Correction
Vehicle Drive Train Not Correctly Matched to Engine	Review specifications of engine and drive train components.
OK ↓	
Excessive Load for Engine Horsepower Rating	Reduce vehicle load.
OK ↓	
Engine Operation Above Recommended Altitude	Derate engine above 3600 meters [12,000 feet].
OK ↓	
Turbocharger Incorrect	Check part number versus control parts list (CPL) and replace turbocharger, if necessary.
OK ↓	
Fuel Suction Line or Fuel Filter Restricted	Check fuel line for restriction. Replace fuel filter.
OK ↓	
Lubricating Oil Level Too High	Check dipstick calibration and oil pan capacity.
OK ↓	
Throttle Linkage Adjustment Incorrect	Check throttle linkage adjustment for full opening of throttle lever.
OK ↓	
Intake or Exhaust System Restricted	Check intake and exhaust systems for restrictions.
OK ↓	
Intake Air, Aftercooler, or Exhaust Gas Leak	Check for loose or damaged piping connections or missing pipe plugs. Check turbocharger and exhaust manifold mounting.
OK ↓	
Air in Fuel (Spongy Throttle is Symptom)	Check for air in fuel. Tighten fuel connections and filter. Check fuel tank stand pipe.
OK ↓	

(Continued)

SYMPTOM: Engine Power Output Low (Continued)

Cause	Correction
Fuel Drain Line Restricted or Fuel Tank Vents Plugged	Check fuel drain line for loops, crimps, or clamped points. Remove, clean, or replace vents.
OK	
Fuel Quality Poor	Verify by operating engine from a temporary tank that contains good fuel. Refer to Fuel Oil Specifications.
OK	
High Fuel Temperatures (Above 70°C [158°F])	Fill fuel tanks. Turn off fuel heater.
OK	
Contact a Cummins Authorized Repair Facility	



SYMPTOM: Engine Runs Rough at Idle

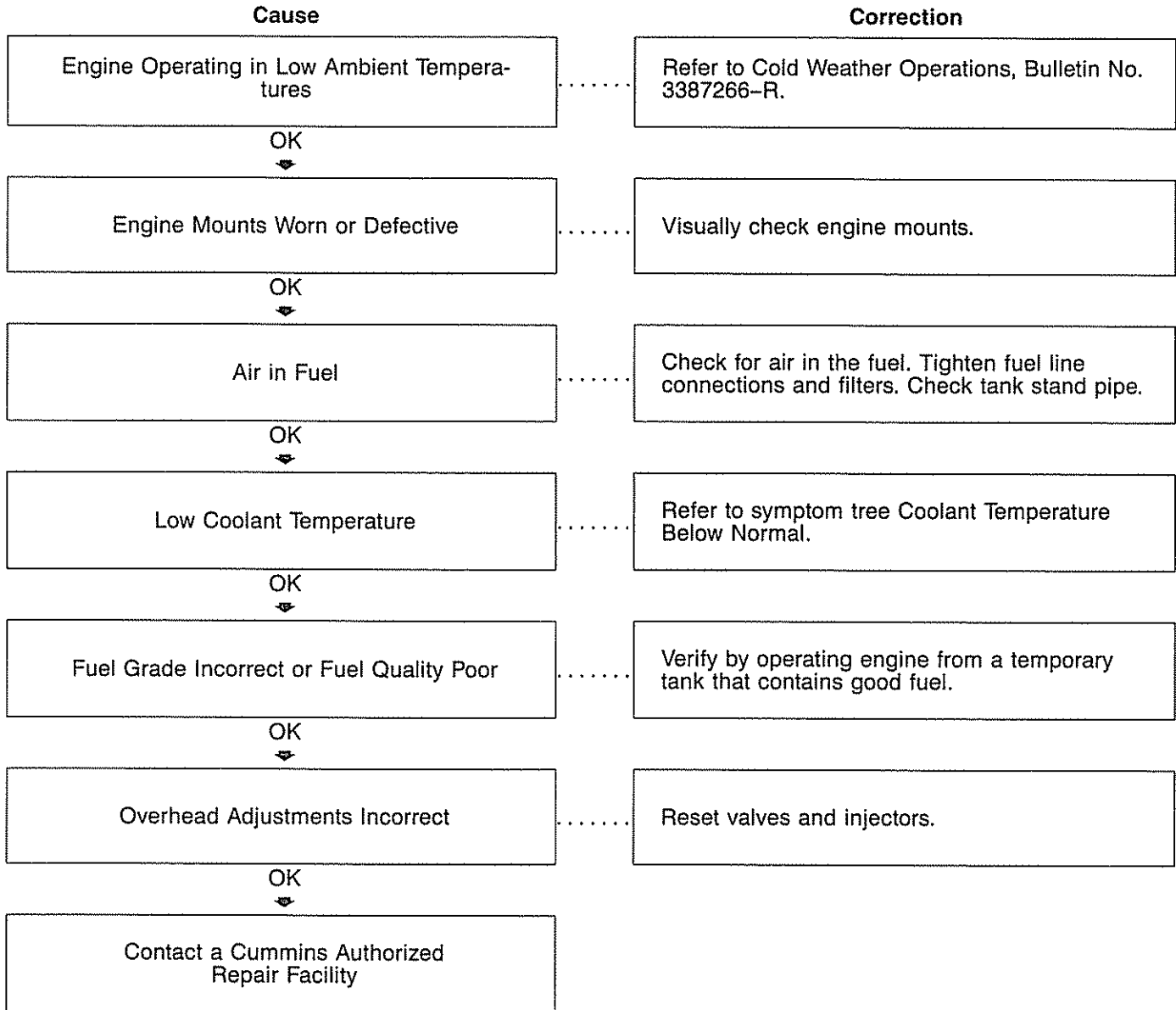

SYMPTOM: Engine Runs Rough or Misfires

Cause	Correction
Condition Only Occurs at Idle	Refer to the symptom chart Engine Runs Rough at Idle.
OK	
Engine Operating in Low Ambient Temperature	Refer to Cold Weather Operation, Bulletin No. 3387266-R.
OK	
Fuel Injection Lines Leaking	Inspect and correct leaks in fuel lines and fittings.
OK	
Fuel Grade Incorrect or Fuel Quality Poor	Verify by operating the engine with clean fuel from a temporary tank.
OK	
Air in Fuel	Check for air in the fuel. Tighten the fuel line connections and filter(s).
OK	
Fuel Supply Line Restriction Excessive	Check for plugged fuel filter and/or excessive fuel supply line restriction. Refer to Section V for specifications.
OK	
Overhead Adjustment Incorrect	Check for a bent or mislocated push rod, crossheads, and rocker levers. Adjust overhead.
OK	
Contact a Cummins Authorized Repair Facility	

SYMPTOM: Engine Shuts Off Unexpectedly or Dies During Deceleration

Cause	Correction
Engine Will Not Restart	Refer to symptom chart Engine Will Not Start
OK ↓	
Fuel Inlet Restriction or Air in the Fuel	Check fuel tanks, fuel filter, fuel lines, connections, and fuel cooling plate.
OK ↓	
Low Battery Voltage	Check battery power supply circuits.
OK ↓	
Fuel Shutoff Solenoid Voltage Low. Fuel Shutoff Valve Closed	Check fuel shutoff solenoid valve circuit.
OK ↓	
Contact a Cummins Authorized Repair Facility	

SYMPTOM: Engine Speed Surges at Low Idle

Cause	Correction
Fuel Level Low in the Tank	Fill supply tank.
OK	
Fuel Inlet Restriction or Air in the Fuel	Change fuel filter(s). Check for air in the fuel. Tighten the fuel line connections and filter(s).
OK	
Return Fuel Line Restricted or Plugged	Replace fuel drain line.
OK	
Contact a Cummins Authorized Repair Facility	



SYMPTOM: Engine Speed Surges (Other Than Low Idle)

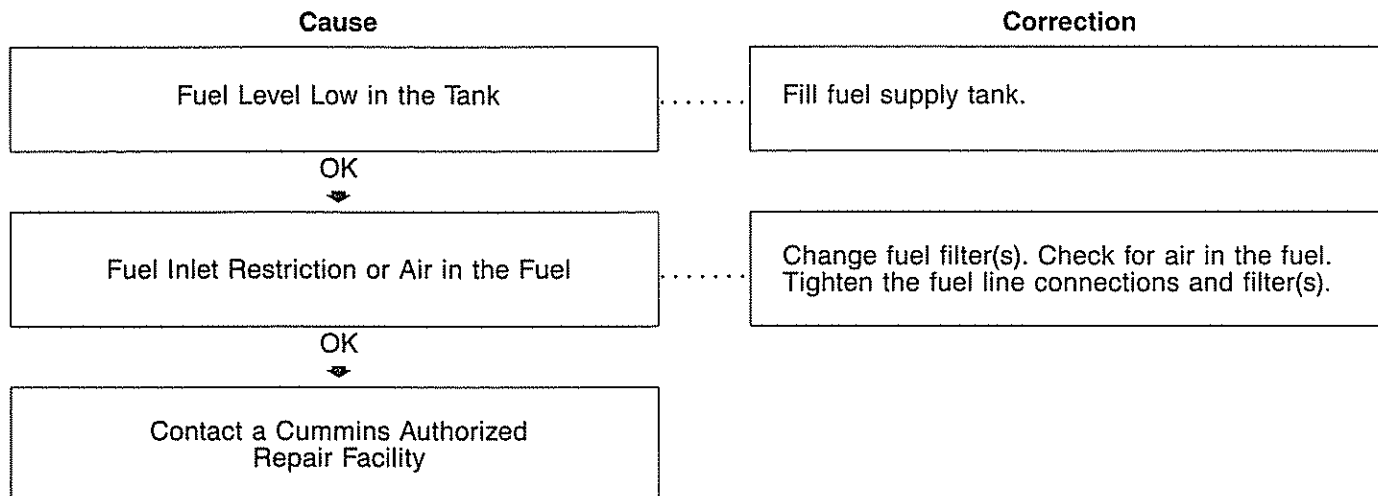

SYMPTOM: Engine Starts But Will Not Keep Running

Cause	Correction
Fuel Level in Tank Too Low	Add fuel.
OK	
Engine Driven Units Engaged	Disengage engine driven units.
OK	
Air in the Fuel System	Check for air in fuel. Tighten fuel connections. Tighten filter. Check fuel tank stand pipe.
OK	
Fuel Filter Plugged or Fuel Waxing Due to Cold Weather	Replace fuel filter. Weather conditions can require fuel heater.
OK	
Fuel Suction Line Restricted	Inspect fuel line for restriction.
OK	
Fuel Contaminated	Verify by operating engine from a temporary supply tank.
OK	
Intake or Exhaust System Restricted	Check intake and exhaust restriction.
OK	
Contact a Cummins Authorized Repair Facility	

SYMPTOM: Engine Vibration Excessive

Cause	Correction
Engine Misfiring	Refer to symptom tree Engine Runs Rough or Misfires.
OK	
Engine Idle Speed Too Low	Adjust idle speed.
OK	
Fan is Loose, Damaged or Unbalanced	Check fan.
OK	
Engine Belt Driven Accessories Malfunctioning: Fan Hub, Alternator, Freon Compressor, Hydraulic Pump or Air Compressor	Check for interference. Loosen belt, if applicable, to isolate component from vibration.
OK	
Engine Mounts Worn or Defective	Visually check engine mounts.
OK	
Contact a Cummins Authorized Repair Facility	

SYMPTOM: Engine Will Not Crank or Cranks Slowly (Air Starting Motor)

Cause	Correction
Air Pressure Insufficient in Air Tank	Increase pressure using external air supply.
OK ↓	
Engine Drive Units Engaged	Disengage engine driven units.
OK ↓	
Oil Incorrect for Operating Conditions	Change oil and filters. Use the type recommended (15W-40). Check operation.
OK ↓	
Contact a Cummins Authorized Repair Facility	



SYMPTOM: Engine Will Not Crank or Cranks Slowly (Electric Starting Motor)

Cause	Correction
Engine Drive Units Engaged	Disengage engine driven units.
OK ↓	
Battery Connections Broken, Loose, or Corroded	Check for damage. Clean and tighten if necessary.
OK ↓	
Battery Charge Low	Check electrolyte level and specific gravity. Recharge or replace batteries.
OK ↓	
Battery Rating Too Low	Replace battery with correct rating.
OK ↓	
Oil for Operating Conditions Incorrect	Change oil and filters. Use the type recommended (15W-40). Check operation.
OK ↓	
Battery Temperature Too Low	Check battery heater operation. Refer to the manufacturer's instructions.
OK ↓	
Contact a Cummins Authorized Repair Facility	

SYMPTOM: Engine Will Not Reach Rated Speed When Loaded

Cause	Correction
Excessive Load for Engine Horsepower Rating	Reduce vehicle load or use lower gear.
OK ↓	
Tachometer Has a Malfunction	Check with hand or digital tachometer.
OK ↓	
Throttle Linkage Adjustment Incorrect	Check for full throttle travel.
OK ↓	
Fuel Suction Line Restricted	Check fuel inlet for restriction.
OK ↓	
Contact a Cummins Authorized Repair Facility	



SYMPTOM: Engine Will Not Shut Off

Cause	Correction
Fuel Pump Manual Override Open	Check to make sure manual override screw is out to maximum travel.
OK	
Fuel Pump Shutoff Valve Disc Stuck	Check operation of fuel shutdown solenoid.
OK	
Key Switch Circuit Malfunctioning	Check vehicle key switch circuit.
OK	
Fuel Tank Vents Plugged	Remove, clean, or replace vents.
OK	
Fuel Drain Line Restricted	Check fuel drain line for loops, crimps, or clamped points.
OK	
Engine Running on Fumes Drawn into Air Intake	Locate and isolate the source of fumes.
OK	
Contact a Cummins Authorized Repair Facility	

SYMPTOM: Fuel Consumption — Excessive

Cause	Correction
Verify Complaint	If low power is relevant, go to symptom tree Engine Power Output Low. If acceleration is poor, go to symptom tree Engine Acceleration and Response Poor. If excessive fuel consumption is relevant, continue with this chart.
OK ↓	
Oil Level Incorrect	Check oil level.
OK ↓	
Intake Air Restriction Excessive	Visually inspect air filter and restriction indicator. Replace air filter if necessary.
OK ↓	
Fuel Leaks	Visually check fuel system and supply for leaks.
OK ↓	
Driving Technique Incorrect	Refer to Section 1.
OK ↓	
Vehicle and Environmental Factors: (Ambient Temperature, Wind, Tires, Axle Alignment, Routes etc.)	Consider vehicle and environmental factors when evaluating fuel consumption.
OK ↓	
Hourmeter Calibrated Wrong	Repair or calibrate hourmeter. Calculate fuel consumption with readjusted hour figures.
OK ↓	
Contact a Cummins Authorized Repair Facility	

SYMPTOM: Fuel in Coolant

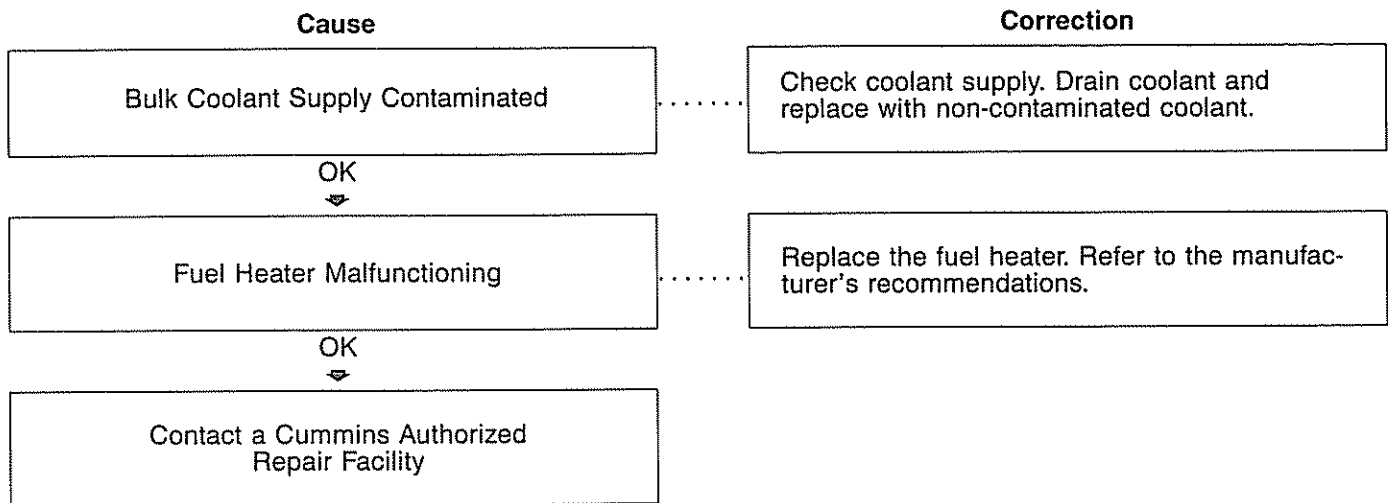

SYMPTOM: Fuel in the Lubricating Oil

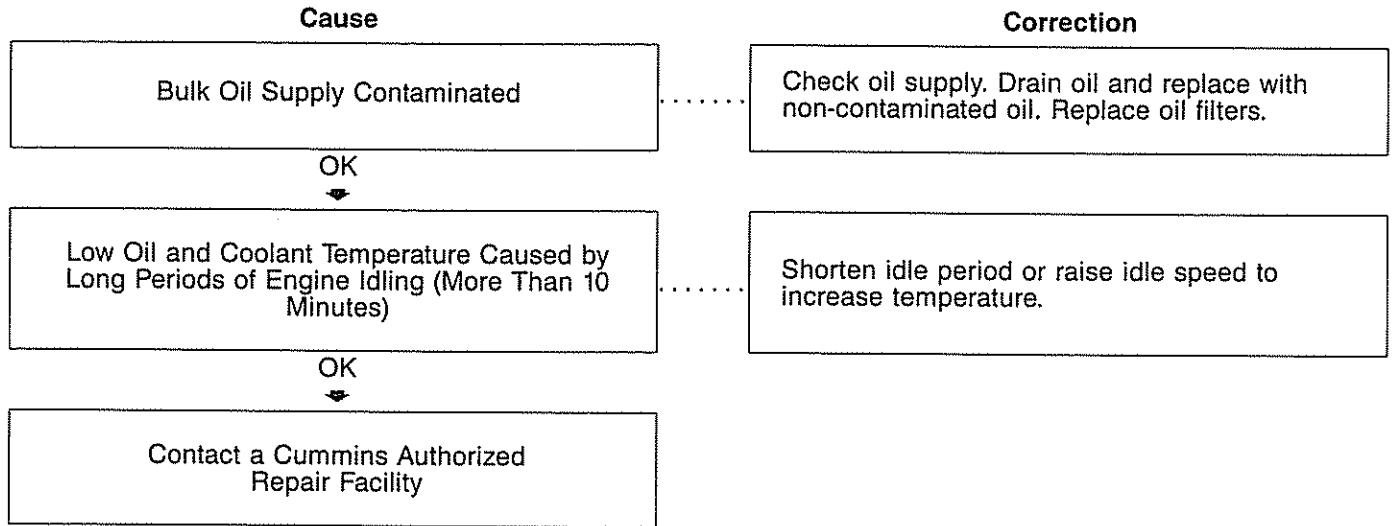

SYMPTOM: Lubricating Oil Consumption Excessive

Cause	Correction
Verify Oil Consumption Rate	Check oil added versus hours.
OK ↓	
External Oil Leaks	Tighten capscrews, pipe plugs, and fittings as needed. Refer to Section V. Replace gaskets as necessary.
OK ↓	
Extended Oil Change Intervals	Check and revise oil change intervals. Refer to Section V.
OK ↓	
Oil Does Not Meet Specifications	Change engine lubricating oil.
OK ↓	
Crankcase Breather or Breather Tube Plugged	Check crankcase breather and tube.
OK ↓	
Contact a Cummins Authorized Repair Facility	

SYMPTOM: Lubricating Oil Contaminated

Cause	Correction
Identify Contamination	Perform an oil analysis to determine the contaminates.
OK ↓	
Bulk Oil Supply Contaminated	Check oil supply. Drain oil and replace with non-contaminated oil. Replace oil filters.
OK ↓	
Oil Sludge Excessive	Refer to symptom tree Lubricating Oil Sludge in the Crankcase Excessive.
OK ↓	
Fuel in the Oil	Refer to symptom tree Fuel in the Lubricating Oil.
OK ↓	
Coolant in the Oil , Internal Engine Component Leaks	Contact an Authorized Repair Facility



SYMPTOM: Lubricating Oil Pressure High

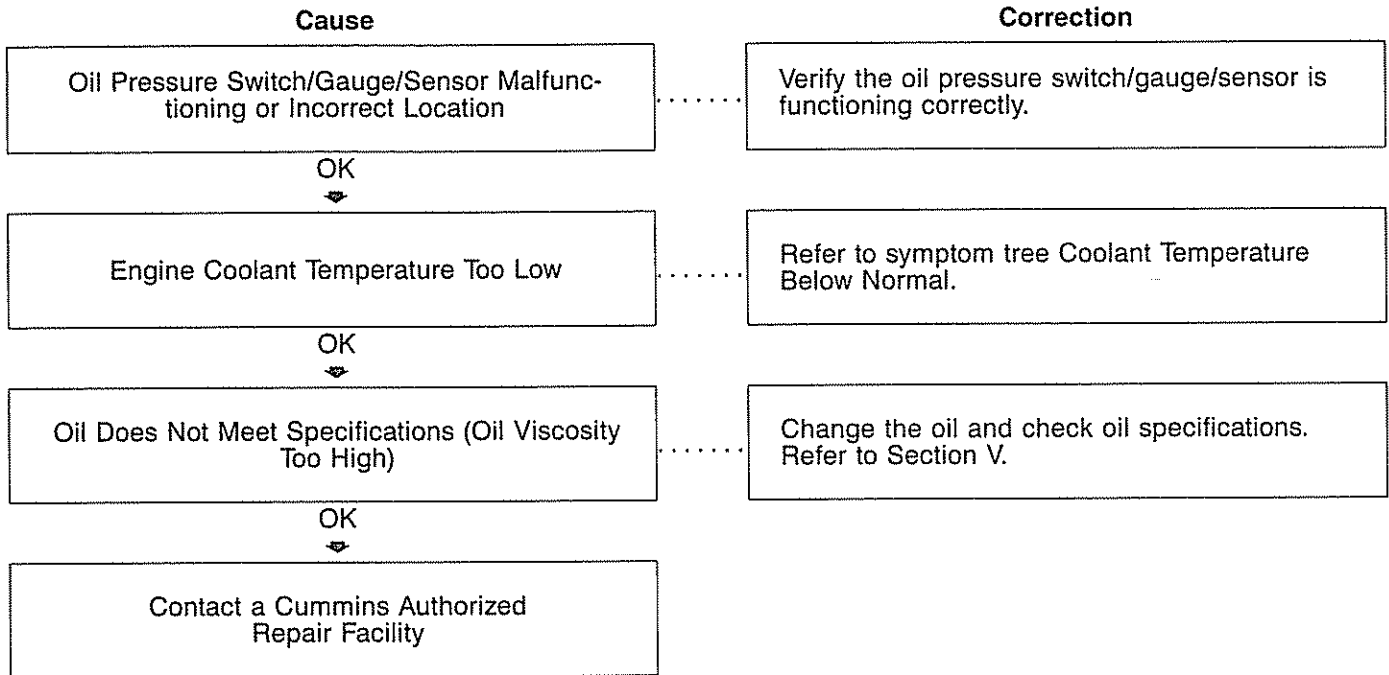

SYMPTOM: Lubricating Oil Pressure Low

Cause	Correction
<p>Incorrect Oil Level</p> <p>OK ↓</p>	<p>Check for oil leaks. Add or drain engine oil. Check dipstick calibration.</p>
<p>External Oil Leaks</p> <p>OK ↓</p>	<p>Visually inspect for oil leaks. Repair as necessary.</p>
<p>Oil Pressure Switch/Gauge/Sensor Malfunctioning or Incorrect Location</p> <p>OK ↓</p>	<p>Verify the pressure switch/gauge/sensor is functioning correctly.</p>
<p>Engine Angularity or Power Angle Exceeding Limit</p> <p>OK ↓</p>	<p>Check power angle in vehicle. Check terrain where low oil pressure occurs. Refer to specifications.</p>
<p>Incorrect Oil Specifications</p> <p>OK ↓</p>	<p>Change oil and check oil specifications.</p>
<p>Oil Temperature Above Normal (120°C [250°F])</p> <p>OK ↓</p>	<p>Refer to symptom tree Lubricating Oil Temperature Above Normal.</p>
<p>Oil Contaminated With Fuel or Coolant</p> <p>OK ↓</p>	<p>Refer to symptom tree Lubricating Oil Contaminated.</p>
<p>Oil Filter(s) Plugged</p> <p>OK ↓</p>	<p>Change oil and filter(s). Review change interval. Refer to Section V.</p>
<p>Contact a Cummins Authorized Repair Facility</p>	

SYMPTOM: Lubricating Oil Sludge in the Engine Crankcase Excessive

Cause	Correction
Bulk Oil Supply Contaminated	Check oil supply. Drain oil and replace with non-contaminated oil. Replace oil filters.
OK ↓	
Oil Does Not Meet Specifications	Change oil and filters. Check oil specifications. Refer to Section V.
OK ↓	
Oil Drain Interval and/or Oil Filter Replacement Interval Incorrect	Check records. Compare to specifications. Refer to Section V.
OK ↓	
Fuel Grade or Fuel Quality Poor or Incorrect.	Check fuel and compare to specifications. Refer to Section V. Inspect/replace fuel filters and fuel.
OK ↓	
Engine Coolant and Oil Temperature Too Low	Refer to symptom tree Coolant Temperature Below Normal.
OK ↓	
Crankcase Breather or Breather Tube Plugged	Check breather and tube.
OK ↓	
Coolant in the Oil	Contact an Authorized Repair Facility.

SYMPTOM: Lubricating Oil Temperature Above Specification

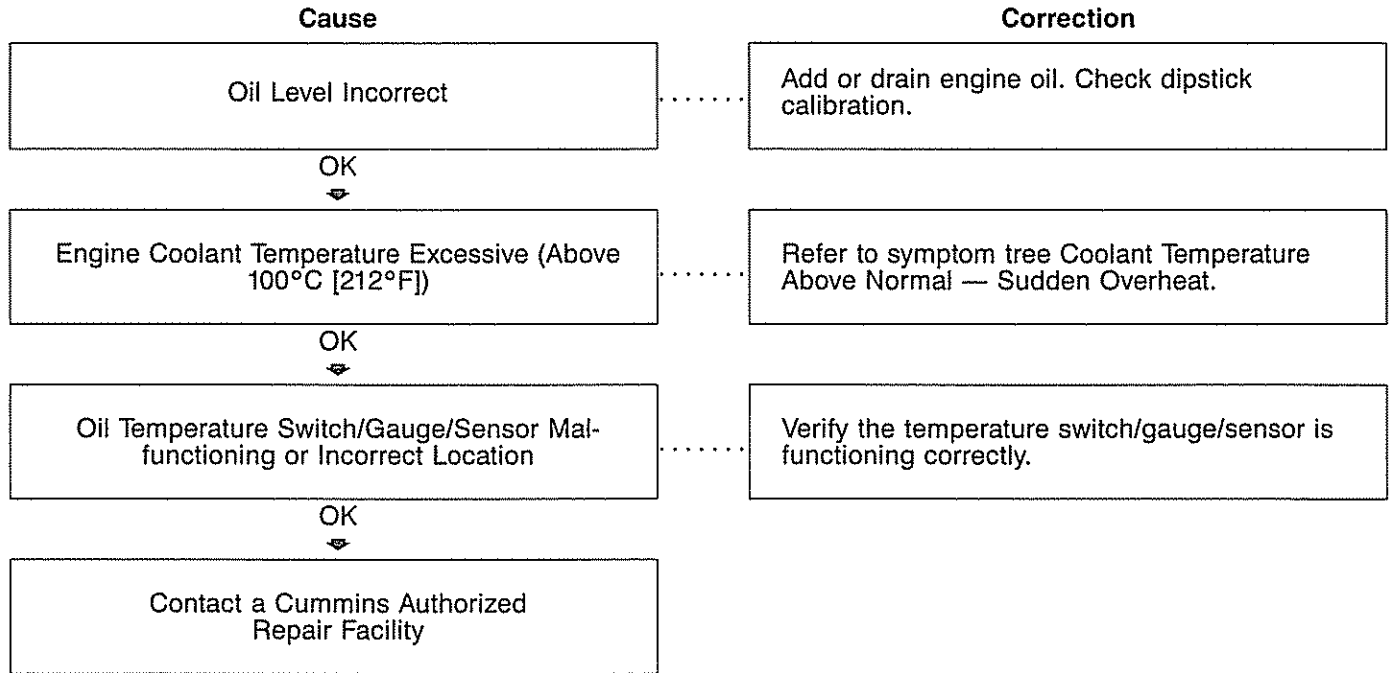

SYMPTOM: Smoke, Black — Excessive

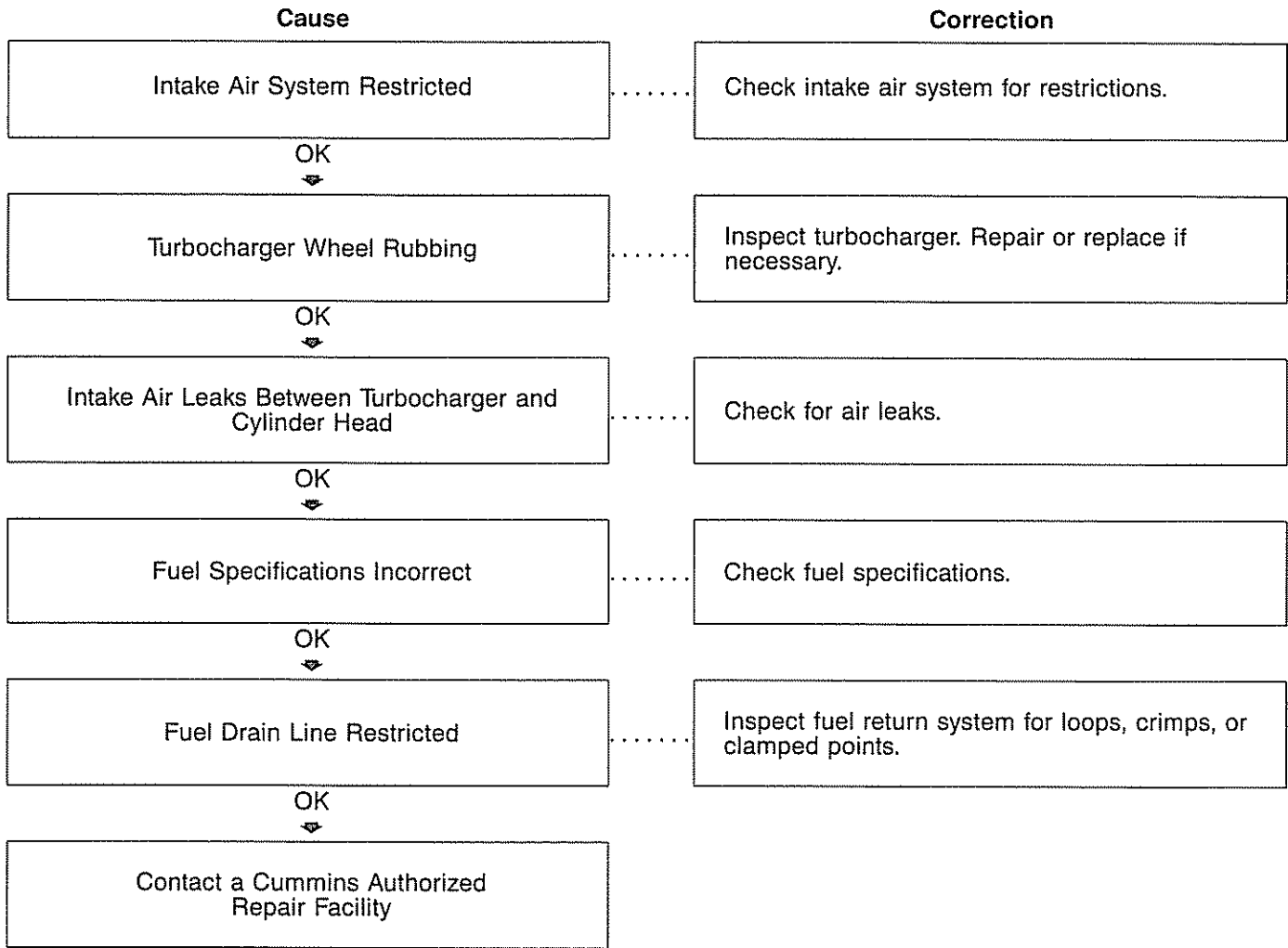

SYMPTOM: Smoke, White — Excessive

Cause	Correction
Engine Block Heater Malfunctioning	Check electrical source and wiring to cylinder block heater. Replace block heater as required. Refer to the manufacturer's instructions.
OK	
Intake Air Temperature Too Low	Check the shutter operation and winterfront.
OK	
Coolant Temperature Too Low	Refer to symptom chart Coolant Temperature Below Normal.
OK	
Fuel Grade Incorrect or Fuel Quality Poor	Verify by operating engine from a temporary tank that contains good fuel. Refer to Section V.
OK	
Overhead Adjustment Incorrect	Check/adjust valves and injectors.
OK	
STC Valve Malfunction	Contact an Authorized Repair Facility



SYMPTOM: Turbocharger Boost Pressure Low

Cause

Correction

Turbocharger Incorrect

Check part number versus control parts list (CPL). Replace turbocharger if necessary. Refer to Control Parts List, Bulletin No. 3379133.

OK



Intake or Exhaust Air Leaks

Check for loose or damaged piping, loose or damaged connections, and missing pipe plugs. Check turbocharger and exhaust manifold mounting.

OK



Air Compressor Connection Loose or Damaged

Check connection between manifold and air compressor. Repair or replace as necessary.

OK



Contact a Cummins Authorized Repair Facility

SYMPTOM: Turbocharger Leaks — Engine Oil or Fuel

Cause	Correction
Operating for Extended Periods Under Light or No-Load Conditions (Slobbering)	Review vehicle operation. Refer to Section 1.
OK ↓	
Engine Oil or Fuel Entering Turbocharger	Remove intake and exhaust piping and check for engine oil or fuel.
OK ↓	
Turbocharger Drain Line Obstructed	Check and clean line.
OK ↓	
Contact a Cummins Authorized Repair Facility	



Section V - Maintenance Specifications

Section Contents

	Page
Arctic Operation	V-20
Capscrew Markings and Torque Values	V-21
Capscrew Markings and Torque Values — Metric	V-22
Capscrew Markings and Torque Values — U.S. Customary	V-23
Coolant Recommendations and Specifications	V-10
Coolant Replacement Requirements	V-17
Cooling System Sealing Additives	V-12
Cooling System Soluble Oils	V-12
Fleetguard® DCA4 Service Filters and Liquid Precharge	V-13
Fully Formulated Coolant/Antifreeze	V-10
Supplemental Coolant Additive (SCA)	V-14
Test Intervals	V-16
Testing SCA Concentration Level CC-2602 Test Kit	V-15
Precautions and Instructions for Proper Kit Use	V-15
Drive Belt Tension	V-18
Engine Component Torque Values	V-19
Fuel Recommendations and Specifications	V-6
Lubricating Oil Recommendations and Specifications	V-7
General Information	V-8
New Engine Break-in Oils	V-7
Arctic Operation Engine Oil	V-7
Oil Drain Intervals	V-9
Specifications	V-1
Air Intake System	V-2
Batteries (Specific Gravity)	V-4
Compressed Air System	V-2
Holset® SS296/SS296E/QE296 A/C Models	V-3
Holset® SS338/QE338 A/C Models	V-2
Holset® ST676 A/C Model	V-3
Cooling System	V-1
Cummins/Fleetguard® Filter Specifications	V-5
Lubricating Oil Filters	V-5
Electrical System	V-4
Exhaust System	V-2
Fuel System	V-1
General Specifications	V-1
Lubricating Oil System	V-1



THIS PAGE LEFT INTENTIONALLY BLANK.

Specifications

General Specifications

Horsepower (Refer to engine dataplate)

Engine speed @ Maximum Output:

Standard Rating (rpm) 2100

Bore and Stroke 125 mm [4.921 in] x 147 mm [5.787 in]

Displacement 10.8 liters [661 C.I.D.]

Firing Order 1-5-3-6-2-4

Engine Weight (with Standard Accessories):

Dry Weight 929 Kg [2045 lb]

Wet Weight 981 Kg [2160 lb]

Crankshaft Rotation — (viewed from the front of the engine) Clockwise

Fuel System

For performance and fuel rate values, refer to the engine data sheet or the fuel pump code for the particular model involved.

Fuel Inlet Maximum Restriction:

Clean Fuel Filter 102 mm Hg [4 in Hg]

Dirty Fuel Filter 204 mm Hg [8 in Hg]

Fuel Drain Line Maximum Restriction

Without Check Valves 63 mm Hg [2.5 in Hg]

With Check Valves 165 mm Hg [6.5 in Hg]

Fuel Inlet Maximum Temperature 71°C [160°F]

Engine Minimum Cranking Speed 150 RPM

Lubricating Oil System

Oil Pressure:

Low Idle (Minimum Allowable) 70 kPa [10 psi]

At 1200 rpm or Torque Peak (Minimum Allowable) 207 kPa [30 psi]

Oil Capacity of Standard Engine:

Combination Filter 2.6 liters [0.7 U.S. gallon]

Oil Pan (High-Low) 34 - 26.5 liters [9 - 7 U.S. gallon]

Cooling System

Coolant Capacity (Engine only-Aftercooled) 12.9 liters [3.4 U.S. gal.]

Standard Modulating Thermostat-Range 82° to 93°C [180 to 200°F]

Cylinder Block Coolant Pressure (Pressure Cap Removed):

Minimum

Closed Thermostat - 1800 RPM - No Load 138 kPa [20 psi]

Maximum

Closed Thermostat 275 kPa [40 psi]

Maximum Allowable Operating Temperature 100°C [212°F]

Minimum Recommended Operating Temperature 71°C [160°F]

Maximum Allowable Deaeration Time 35 minutes

Minimum Recommended Pressure Cap 48 kPa [7 psi]

Air Intake System

Maximum Temperature Rise Between Ambient Air and Engine Inlet Air: (Ambient (Above 0° [32°F])	17°C [30°F]
Maximum Intake Restriction (Clean Air Filter Element)	254 mm H ₂ O [10.0 in H ₂ O]
Maximum Intake Restriction (Dirty Air Filter Element)	635 mm H ₂ O [25.0 in. H ₂ O]

Exhaust System

Maximum Back Pressure From Piping and Silencer (Combined):	
Hg	76 mm [3 in]
H ₂ O	1016 mm [40 in]
Exhaust Pipe Size (Normally Acceptable Inside Diameter)	102 mm [4 in.]

Compressed Air System

Holset® SS338/QE338 A/C Models

Cylinders	1
Compressor Swept Volume @ 1250 RPM	6.2 L per sec. [13.20 CFM]
Piston Displacement	296 cc [18.06 C.I.D.]
Bore	92.08 mm [3.625 in.]
Stroke	44.45 mm [1.750 in.]
Speed	Engine Speed
Cooling	Engine Coolant
Lubrication	Engine Lubricating Oil
Plumbing Line Sizes	
Coolant Inlet and Outlet (Pipe Fitting)	0.375 in. NPTF
Air Inlet (Inside Diameter)	22.22 mm [0.875 in.]
Air Outlet (Minimum Inside Diameter)	12.7 mm [0.50 in.]
Height, Overall (Approximate)	31.1 cm [12.25 in.]
Width, Overall (Approximate)	14.6 cm [5.75 in.]
Length, Overall (Approximate)	22.9 cm [9.00 in.]
Weight (Approximate)	18 kg [40.0 lbs]

Holset® SS296/SS296E/QE296 A/C Models

Cylinders	1
Compressor Swept Volume @ 1250 RPM	7.1 L per sec. [15.0 CFM]
Piston Displacement	338 cc [20.63 C.I.D.]
Bore	98.4 mm [3.875 in]
Stroke	44.5 mm [1.75 in]
Speed	Engine Speed
Cooling	Engine Coolant
Lubricating	Engine Lubricating Oil
Plumbing Line Sizes:	
Coolant Inlet and Outlet (Pipe Fitting)	0.375 in NPTF
Air Inlet	22.22 mm [0.875 in]
Air Outlet	12.7 mm [0.50 in]
Height, Overall (Approximate)	31.1 cm [12.25 in]
Width, Overall (Approximate)	14.6 cm [5.75 in]
Length, Overall (Approximate)	22.9 cm [9.00 in]
Weight (Approximate)	18 Kg [40.0 lbs]

Holset® ST676 A/C Model

Cylinders	2
Compressor Swept Volume @ 1250 RPM	14.2 L per sec. [30.00 CFM]
Piston Displacement	676 cc [41.3 C.I.D.]
Bore	92.08 mm [3.625 in.]
Stroke	50.8 mm [2.00 in.]
Speed	Engine Speed
Cooling	Engine Coolant
Lubrication	Engine Lubricating Oil
Coolant Inlet and Outlet (Pipe Fitting)	0.50 in. NPTF
Air Inlet (Inside Diameter)	22.22 mm [0.875 in.]
Air Outlet (Minimum Inside Diameter)	15.88 mm [0.625 in.]
Height, Overall (Approximate)	34.3 cm [13.50 in.]
Width, Overall (Approximate)	17.8 cm [7.00 in.]
Length, Overall (Approximate)	28.7 cm [11.30 in.]
Weight (Approximate)	33.5 kg [74.50 lbs.]

NOTE: In applications where duty cycles average 10 percent or more, or air pressures are above 862 kPa [125 psi]; use a discharge line with a minimum inside diameter of 15.9 mm [0.625 in] for single cylinder compressors and 25.4 mm [1.00 in] for twin cylinder compressors to prevent carbon buildup. Examples of these applications are as follows: refuse trucks, pickup and delivery trucks, transit buses and equipment with high accessory air usage.

Electrical System

Minimum Recommended Battery Capacity

System Voltage	Ambient Temperature			
	-18°C [0°F]		0°C [32°F]	
	Cold Cranking Amperes	Reserve Capacity ¹ Amperes	Cold Cranking Amperes	Reserve Capacity ¹ Amperes
12 Volt	1800	640	1280	480
24 Volt ²	900	320	640	240

1. The number of plates within a given battery size determines reserve capacity. Reserve capacity determines the length of time which sustained cranking can occur.
2. CCA ratings are based on two 12 volt batteries in series.

A minimum of 9 volts at the ECM connector is required to power-up the ECM on CENTRY engines.

Batteries (Specific Gravity)

Specific Gravity at 27°C [80°F]	State of Charge
1.260 to 1.280	100%
1.230 to 1.250	75%
1.200 to 1.220	50%
1.170 to 1.190	25%
1.110 to 1.130	Discharged

Cummins/Fleetguard® Filter Specifications

Fleetguard is a subsidiary of Cummins Engine Company. Fleetguard filters are developed through joint testing at Cummins and Fleetguard. Fleetguard filters are standard on new Cummins engines. Cummins Engine Company, Inc. recommends their use.

Fleetguard products meet all Cummins' Source Approval Test standards to provide the quality filtration necessary to achieve the engine's design life. If other brands are substituted, the purchaser should insist on products which the supplier has tested to meet Cummins' high quality standards.

Cummins **cannot** be responsible for problems caused by non-genuine filters which do **not** meet Cummins' performance or durability requirements.

Lubricating Oil Filters

Cummins Engine Company, Inc. requires a lubricating oil filter(s) be used that meets the specifications given in the table below.

Lubricating Oil Filter Specifications			
Per Cummins Source Approval Method (SAM)	Combo (LF3000) 10,634	Full Flow (LF670) 10,509	Bypass (LF777) 10,547
Flow vs. Restriction Pressure differential at 40 GPM maximum	21 kPa [3 psi]	21 kPa [3 psi]	N/A
Element Collapse Pressure differential	1034 kPa [150 psi]	1034 kPa [150 psi]	1034 kPa [150 psi]
Partical Retention Absolute retention, percent of 40 micrometre and above, minimum	N/A	100%	N/A
Percent retention of 20 to 30 micrometre	N/A	95 %	N/A
Hydrostatic Pressure Pressure, minimum	1724 kPa [250 psi]	1724 kPa [250 psi]	1724 kPa [250 psi]



Fuel Recommendations and Specifications

▲ WARNING ▲

Do not mix gasoline or alcohol with diesel fuel. This mixture can cause an explosion.

▲ CAUTION ▲

Due to the precise tolerances of diesel injection systems, it is extremely important that the fuel be kept clean and free of dirt or water. Dirt or water in the system can cause severe damage to both the fuel pump and the fuel injectors.

▲ CAUTION ▲

Do not use diesel fuel blended with lube oil in engines equipped with a catalytic converter. Damage to the converter will result.

Cummins Engine Company, Inc. recommends the use of ASTM No. 2 D fuel. The use of No. 2 diesel fuel will result in optimum engine performance.

At operating temperatures below 0°C [32°F], acceptable performance can be obtained by using blends of No. 2 D and No. 1 D.

NOTE: Lighter fuels can reduce fuel economy.

The viscosity of the fuel **must** be kept above 1.3 cSt at 40°C [104°F] to provide adequate fuel system lubrication.

The following chart lists acceptable alternate fuels for M11 Plus engines.

Acceptable Substitute Fuels - Cummins CELECT™ Plus Fuel System									
No. 1D Diesel	No. 2D Diesel	No. 1K Kerosene	Jet-A	Jet-A1	JP-5	JP-8	Jet-B	JP-4	CITE
1	OK	1	1	1	OK	OK	NOT OK	NOT OK	NOT OK

1. OK - ONLY if fuel lubricity is adequate. Refer to Fuel for Cummins Engines, Bulletin No. 3379001.
 2. Acceptable ONLY if
 - chrome plated injector plated injector plungers fuel additive AND the heavy duty carbon graphite bushed gear pump are used, or
 - the fuel is blended with enough fuel additive to increase the lubricity above the minimum level. Refer to Fuel for Cummins Engines, Bulletin No. 3379001.
NOTE: Any adjustment to compensate for reduced performance with a fuel system using substitute fuel is not warrantable.

Additional information for fuel recommendations and specifications can be found in Fuel for Cummins Engines, Bulletin No. 3379001. See ordering information in the back of this manual.

Lubricating Oil Recommendations and Specifications

New Engine Break-in Oils

Special "break-in" engine lubricating oils are **not** recommended for new or rebuilt Cummins engines. Use the same type oil during the "break-in" as that which is used in normal operation.

⚠ CAUTION ⚠

A sulfated ash limit of 1.85 percent has been placed on all engine lubricating oils recommended for use in Cummins engines. Higher ash oils can cause valve and/or piston damage and lead to excessive oil consumption.

Additional information regarding lubricating oil availability throughout the world is available in the E.M.A. Lubricating Oils Data Book for Heavy Duty Automotive and Industrial Engines. The data book can be ordered from the Engine Manufacturers Association, One Illinois Center, 111 East Wacker Drive, Chicago, IL U.S. A. 60601. The telephone number is: (312) 644-6610.

Arctic Operation Engine Oil

⚠ CAUTION ⚠

The use of a synthetic base oil does not justify extended oil change intervals. Extended oil change intervals can decrease engine life due to factors such as corrosion, deposits, and wear.

If an engine is operated in ambient temperatures consistently below -23°C [-10°F] and there are no provisions to keep the engine warm when it is **not** in operation, use a synthetic CE/SF engine oil with adequate low temperature properties such as 5W-20 or 5W-30.

The oil supplier **must** be responsible for meeting the performance service specifications



General Information

The use of quality engine lubricating oils combined with appropriate oil drain and filter change intervals is a critical factor in maintaining engine performance and durability.

Cummins Engine Company, Inc. recommends the use of a high quality SAE 15W-40 heavy duty engine oil, such as Cummins Premium Blue, which meets the American Petroleum Institute (API) performance classification CG-4 or CF-4.

NOTE: In areas where CG-4 or CF-4 engine oils are **not** yet available, contact your Cummins Distributor for other oil recommendations.

A sulfated ash limit of 1.0 mass percent is suggested for optimum valve and piston deposit, and oil consumption control. The sulfated ash **must not** exceed 1.85 mass percent.

For further details and discussion of engine lubricating oils for Cummins engines, refer to Cummins Engine Oil Recommendations, Bulletin No. 3810340.

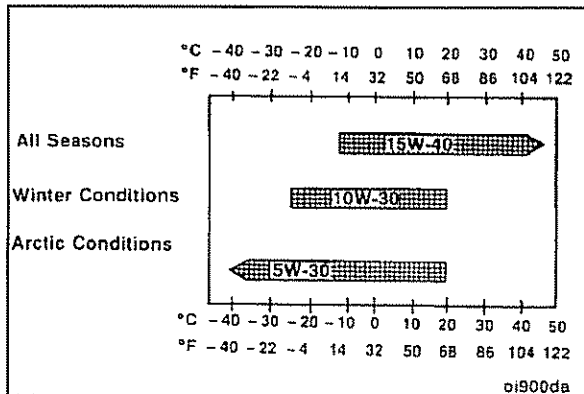

The use of low viscosity oils, such as 10W or 10W-30 can be used to aid in starting the engine and in providing sufficient oil flow at ambient temperatures below -5°C [23°F]. However, continuous use of low viscosity oils can decrease engine life due to wear. Refer to the accompanying chart.

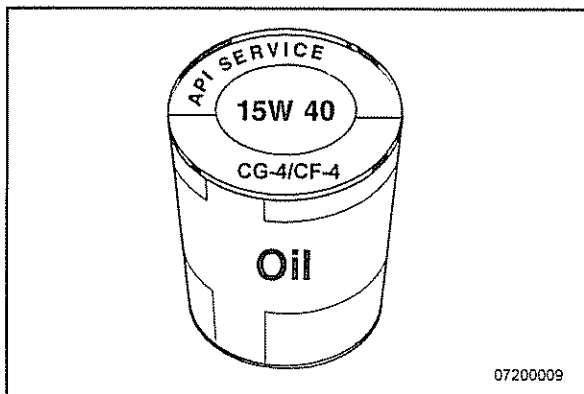

The API service symbols are shown in the accompanying illustration. The upper half of the symbol displays the appropriate oil categories.

The lower half can contain words to describe oil energy conserving features.

The center section identifies the SAE oil viscosity grade.

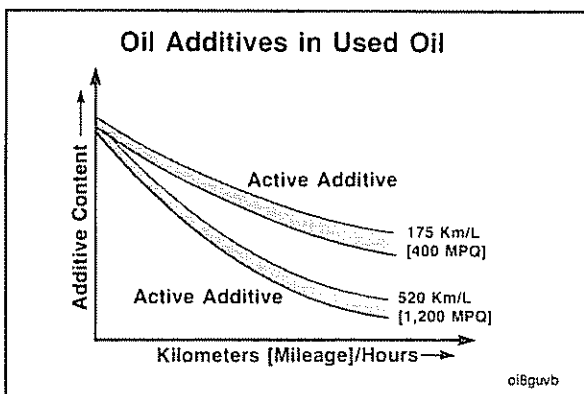

As the engine oil becomes contaminated, essential oil additives are depleted. Lubricating oils protect the engine as long as these additives are functioning properly. Progressive contamination of the oil between oil and filter change intervals is normal. The amount of contamination will vary depending on the operation of the engine, kilometers or miles on the oil, fuel consumed, and new oil added.

Extending oil and filter change intervals beyond the recommendations will decrease engine life due to factors such as: corrosion, deposits, and wear.

Refer to the oil drain chart in this section to determine which oil drain interval to use for your application.

Oil Drain Intervals

Do **not** extend lubricating oil and filter change intervals unless the engine is operating with very low fuel consumption and high oil consumption. Extended oil and filter change intervals will decrease engine life due to factors such as: corrosion, deposits and wear.

Use the following table to determine the oil drain interval for your application.

USE THE FOLLOWING OIL DRAIN INTERVALS FOR YOUR APPLICATION		
Vehicle/Equip.	Hrs	Mos
Mining Truck	250	6
Cranes	250	6
Backhoe	250	6
Dozer	250	6
Scraper	250	6
Skidder	250	6
Farm Tractors	250	6
Combines	250	6
Irrigation Equip.	250	6
Generator Set	250	6
Standby Generator	250	12
Air Compressor	250	6



Coolant Recommendations and Specifications

Cummins recommends the use of fully formulated antifreeze or coolant containing a pre-charge of Supplemental Coolant Additive (SCA). The antifreeze or coolant **must** meet the specifications outlined in The Maintenance Council (TMC) Recommended Practice (RP) 329 (ethylene glycol) or RP 330 (propylene glycol). The use of fully formulated antifreeze or coolant significantly simplifies cooling system maintenance.

Copies of TMC specifications can be obtained through Cummins Engine Company, Inc., or by contacting:

**The Maintenance Council
American Trucking Association
2200 Mill Road
Alexandria, VA 22314-5388
Phone (703) 838-1763
Fax (703) 836-6070**

Fully formulated **antifreeze** contains balanced amounts of antifreeze, SCA, and buffering compounds, but does **NOT** contain 50% (percent) water. Fully formulated **coolant** contains balanced amounts of antifreeze, SCA, and buffering compounds already premixed 50/50 with deionized water.

The following pages will give an explanation of water, antifreeze, and SCA's. They will also explain how to test antifreeze and SCA levels.

This section also contains information on cooling system maintenance and a coolant treatment chart that is used to determine the correct SCA service filter.

Alternative maintenance practices for cooling systems can be found in Cummins Coolant Requirements and Maintenance, Bulletin No. 3666132.

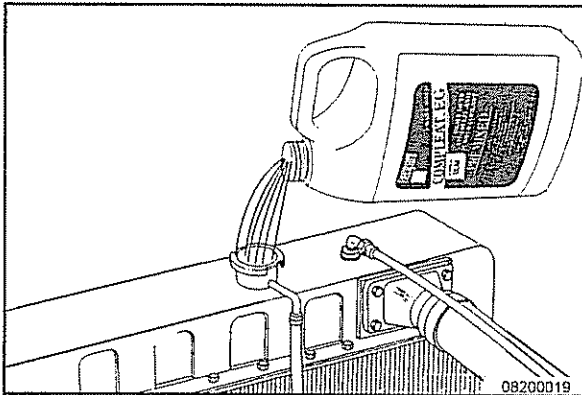

Fully Formulated Coolant/Antifreeze

Cummins Engine Company, Inc. recommends using either a 50/50 mixture of good quality water and fully formulated antifreeze, or fully formulated coolant when filling the cooling system. The fully formulated antifreeze or coolant **must** meet TMC RP 329 or TMC RP 330 specifications.

Water Quality	
Calcium Magnesium (Hardness)	Maximum 170 ppm as (CaCO ₃ + MgCO ₃)
Chloride	40 ppm as (Cl)
Sulfur	100 ppm as (SO ₄)

18200001

Good quality water is important for cooling system performance. Excessive levels of calcium and magnesium contribute to scaling problems, and excessive levels of chlorides and sulfates cause cooling system corrosion.

M11
Section V - Maintenance Specifications

Cummins Engine Company, Inc. recommends using Fleetguard® Compleat. It is available in both glycol forms (ethylene and propylene) and complies with TMC standards.

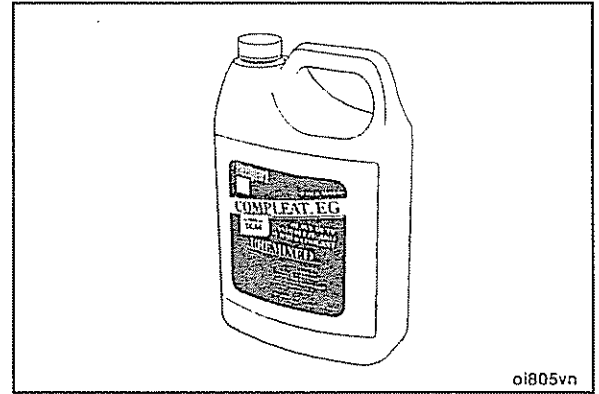

Fully formulated antifreeze **must** be mixed with good quality water at a 50/50 ratio (40 to 60% working range). A 50/50 mixture of antifreeze and water gives a -36°C [-34°F] freeze point and a boiling point of 110°C [228°F], which is adequate for locations in North America. The actual lowest freeze point of ethylene glycol antifreeze is at 68%. Using higher concentrations of antifreeze will raise the freeze point of the solution and increase the possibility of a silicate gel problem.

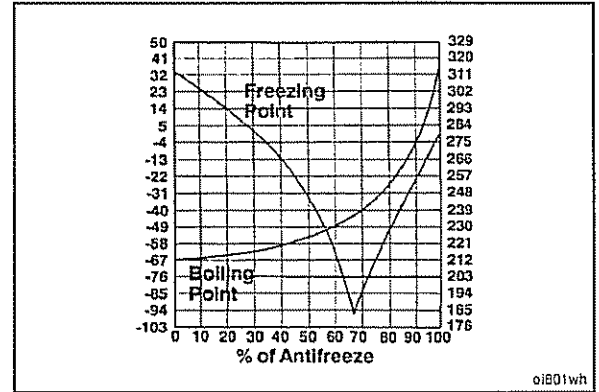

A refractometer **must** be used to **accurately** measure the freeze point of the coolant.

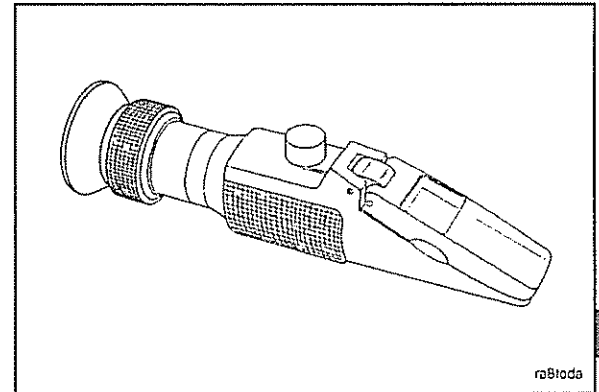

Do **not** use a floating ball hydrometer. Using floating ball hydrometers can give incorrect reading.

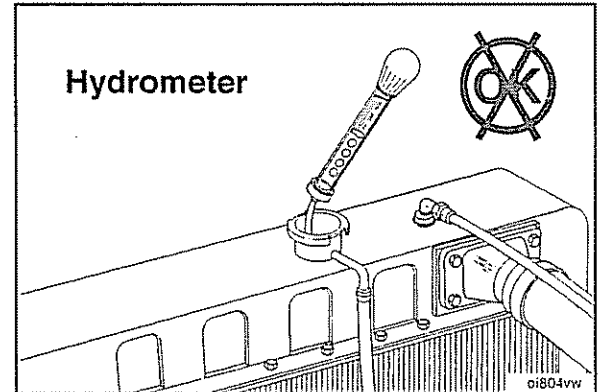

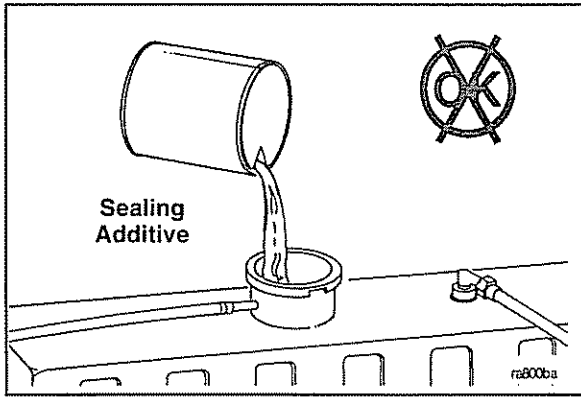

Cooling System Sealing Additives

Do **not** use sealing additives in the cooling systems. The use of sealing additives will:

- build up in coolant low flow areas,
- clog coolant filters,
- plug radiator and oil cooler.

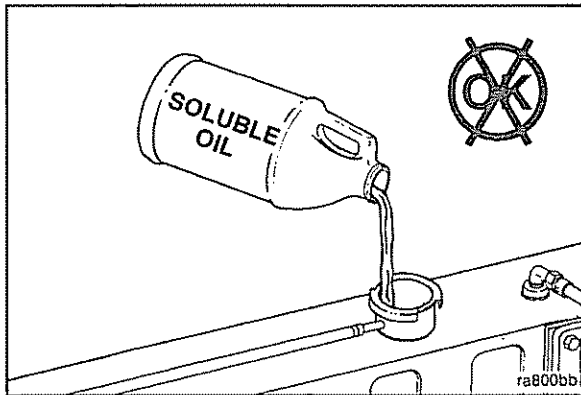

Cooling System Soluble Oils

Do **not** use soluble oils in the cooling system. The use of soluble oils will:

- allow cylinder liner pitting,
- corrode brass and copper,
- damage heat transfer surfaces,
- damage seals and hoses.

Fleetguard® DCA4 Service Filters and Liquid Precharge

DCA4 Service Filters:		DCA (Fleetcool) Service Filters:	
Part No.	SCA Units	Part No.	SCA Units
WF2070	2	WF2050	2
WF2071	4	WF2051	4
WF2072	6	WF2052	6
WF2073	8	WF2053	8
WF2074	12	Not Available	12
WF2075	15	WF2054	15
WF2076	23	WF2055	23
WF2077	(blank filter without SCAs)	WF2077	(blank filter without SCAs)

DCA4 Liquid			DCA (Fleetcool) Liquid		
Part No.	Size	SCA Units	Part No.	Size	SCA Units
DCA60L	0.47 l [1 U.S. pt.]	5	DCA30L	0.47 l [1 U.S. pt.]	5
DCA65L	1.89 l [2 U.S. qt.]	20	DCA35L	1.89 l [2 U.S. qt.]	20
DCA70L	3.78 l [1 U.S. gal]	40	DCA40L	3.78 l [1 U.S. gal]	40
DCA75L	18.9 l [5 U.S. gal]	200	DCA45L	18.9 l [5 U.S. gal]	200
DCA80L	208 l [55 U.S. gal]	2200	DCA50L	208 l [55 U.S. gal]	2200

Maintenance Intervals for Cooling Systems up to 76 Liters [20 U.S. Gallons]						
Install service filter(s) and/or liquid containing number of SCA units below:						
Service Interval	System Size in Liters [U.S. Gallons]					
	Kilometers	[Miles]	[Hours]	4-19 [1-5]	19-38 [6-10]	42-57 [11-15]
72001-80000	[45001-50000]	1126-1250	8	12	23	30
64001-72000	[40001-45000]	1001-1125	4	12	15	26
56001-64000	[35001-40000]	876-1000	4	8	12	23
48001-56000	[30001-35000]	751-875	4	6	12	20
40001-48000	[25001-30000]	626-750	4	6	10	18
32001-40000	[20001-25000]	501-625	2	6	8	15
24001-32000	[15001-20000]	376-500	2	4	6	12
16001-24000	[10001-15000]	251-375	2	4	6	8
0-16000	[0-10000]	0-250	2	2	4	6

Maintenance Intervals for Cooling System up to 1514 Liters [400 U.S. Gallons]										
Install service filter(s) and/or liquid containing number of SCA units below:										
Service Interval	System Size in Liters [U.S. Gallons]									
	79-144 [21-30]	117-189 [31-50]	193-284 [51-75]	288-378 [76-100]	382-568 [101-150]	572-757 [151-200]	761-946 [201-250]	950-1135 [251-300]	1139-1325 [301-350]	1329-1574 [351-400]
751-1000	25	50	80	100	150	200	250	300	350	400
501-750	20	35	60	75	110	150	190	225	260	300
251-500	15	25	40	50	75	100	125	150	175	200
0-250	10	15	20	25	40	50	65	75	90	100

Notes:

- A. Consult the vehicle equipment manufacturer's maintenance information for total cooling system capacity.
- B. When draining and replacing the coolant, **always** pre-charge the cooling system to a SCA level of 1.5 units per gallon. This concentration level **must never** be allowed to go below 1.2 units and **must** be controlled when the level is greater than 3 units. Action needed when the level goes below 1.2 is a filter and liquid pre-charge; from 1.2 to 3.0 units, filter only; above 3.0, test at every oil change until level falls to 3.0 or below.

NOTE: When performing service which requires draining the cooling system, take special precautions to collect it in a clean container, seal it to prevent contamination, and save for reuse.

- C. Change coolant filters at each oil change to protect the cooling system. Consult the coolant capacity chart to determine the correct coolant filter for a given cooling system capacity and oil drain interval.

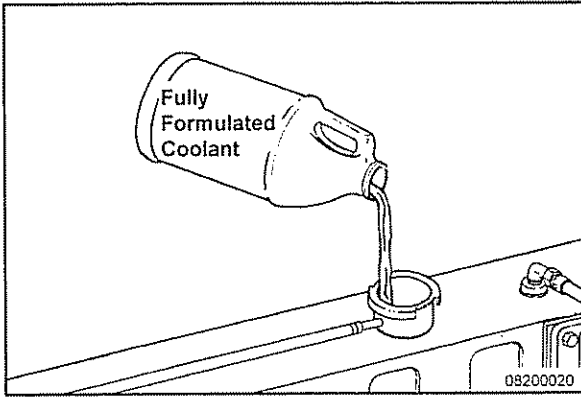

Supplemental Coolant Additive (SCA)

Fully formulated products contain SCA's and are required to protect the cooling system from fouling, solder blooming, and general corrosion. The cooling filter is required to protect the coolant system from abrasive materials, debris, and precipitated coolant additives.

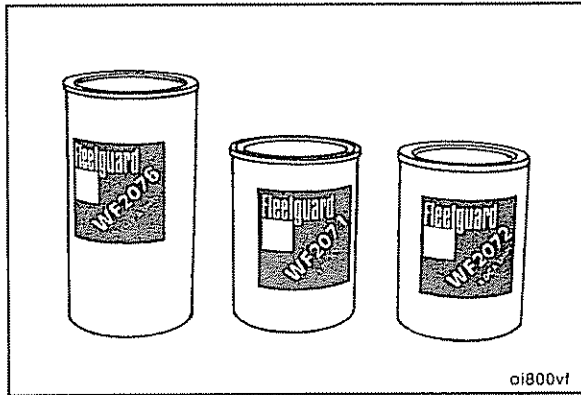

Supplemental coolant additives, or equivalent, are used to prevent liner pitting, corrosion, and scale deposits in the cooling system.

Use the correct Fleetguard® coolant filter to maintain the recommended SCA concentration in the system.

Maintain the correct concentration by changing the service filter at each oil drain interval.

NOTE: The correct filter is determined by the total cooling system capacity and oil drain interval. Refer to the Coolant Capacity Charts.

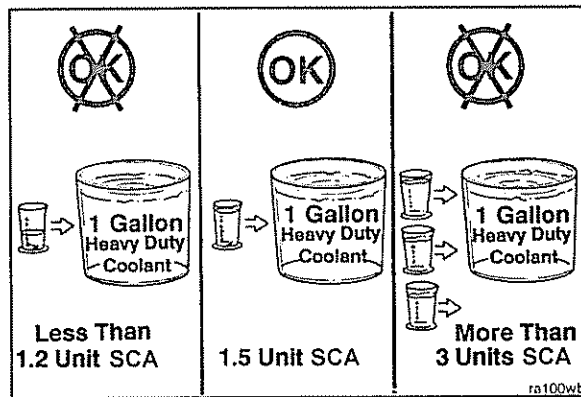

⚠ CAUTION ⚠

Insufficient concentration of the coolant additives will result in liner pitting and engine failure.

The SCA concentration **must not** fall below 1.2 units or exceed 3 units per gallon of cooling system capacity.

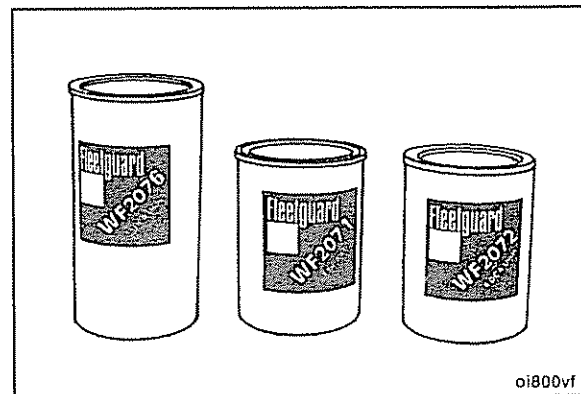

Use the correct Fleetguard® coolant filter to maintain the recommended SCA concentration in the system.

Maintain the correct concentration by changing the service coolant filter at each oil drain interval.

NOTE: The correct filter is determined by the total cooling system capacity and oil drain interval.

Testing SCA Concentration Level CC-2602 Test Kit

Carefully follow the instructions to test the coolant and take the appropriate action recommended by the kit.

Precautions and Instructions for Proper Kit Use

- The coolant sample to be tested **must** be between 10° and 54°C [50° and 130°F]. If the sample is too cold or too hot, you will get incorrect results.
- To get the best color match results, compare test strip pads to the color chart in daylight or under cool white fluorescent lighting. If unsure about a specific color match when a test does fall between two colors on the color chart, choose the lower numbered block. It is safer to underestimate your results than to overestimate.
- The test strips do have a limited shelf life and are sensitive to humidity and extreme heat. Proper handling and storage is necessary to protect the life of the strips.
- Keep the cap tightly sealed on the test strip bottle except when removing a strip. Store away from direct sunlight and in an area where the temperature will generally stay below 32°C [90°F].
- Do **not** use the test strips after the expiration date stamped on the bottle.
- Discard the kit if any of the pads on the unused strips have turned light brown or pink.
- Use one strip at a time and take care **not** to touch any of the pads on the strip. Doing so will contaminate the pads and affect the test results.
- If the strip container is left uncapped for 24 hours, moisture in the air will render the strips useless, although no discoloration will be evident.
- Only use the color chart supplied with the kit.
- Clean and dry the sample cup and syringe after each use. This will prevent contaminating future samples.
- Following the correct test times is very important. Use a clock or stopwatch.



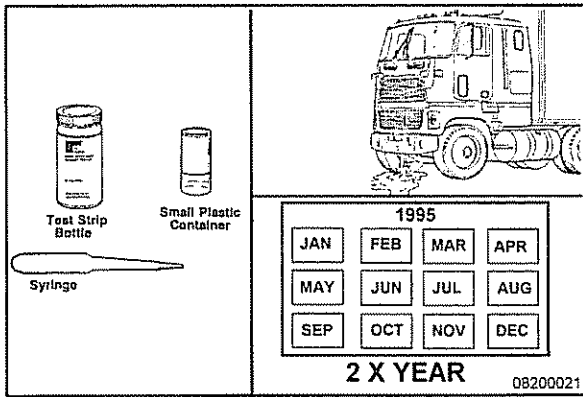

Test Intervals

Testing is recommended if the operator is **not** sure of his cooling system condition due to leaks, uncontrolled topping off of the system, or major coolant loss.

Testing is also recommended twice a year to monitor the SCA level. If the SCA level is above 3 units, test at subsequent oil drain intervals until the concentration is back under 3 units. When the concentration is back under 3 units, start installing the correct service filters at each drain interval.

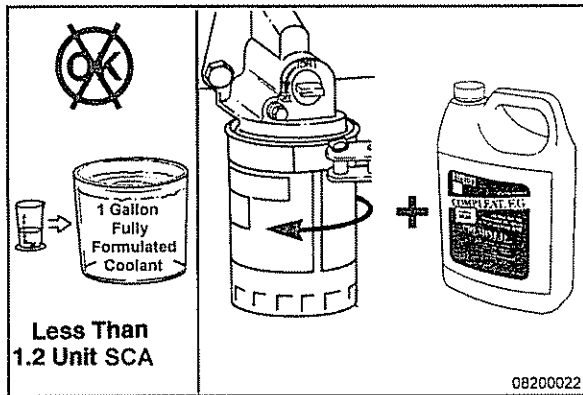

If the concentration is below 1.2 units per gallon, replace the filter and precharge with liquid.

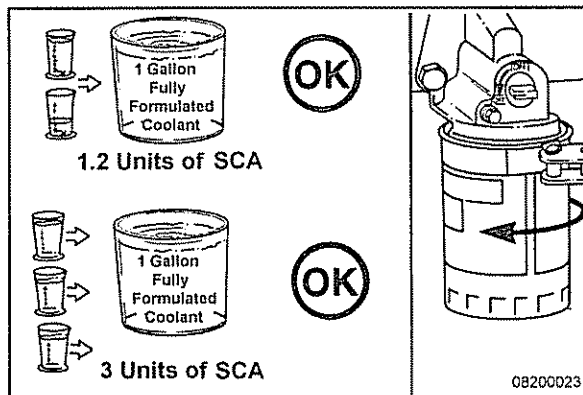

If the concentration is 1.2 to 3 units per gallon, replace the filter.

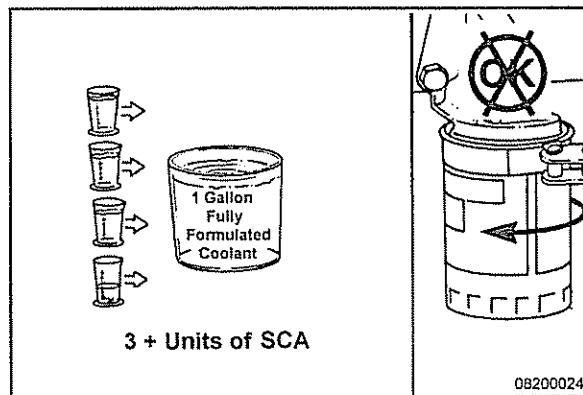

If the concentration is above 3 units per gallon, do **not** replace the service filter. Test the coolant at subsequent oil drain intervals until the concentration is back under 3 units. When the concentration is back under 3 units, start installing service filters at each oil change interval.

M11
Section V - Maintenance Specifications

NOTE: Do **not** utilize the test kit to maintain minimum SCA concentration levels (i.e., 1.5 units).

NOTE: In some instances the A or B reading can be high. However, it is the combined reading that is important. **So, always follow the chart.**

	25%	33%	40%	50%	60%			
	+10	+5	0	-5	-10			
	-20	-30	-45	-60				
Row 4	0.8	1.4	2.5	2.9	3.4	3.8	4.5	5.2
Row 3	0.8	1.4	2.2	2.4	2.8	3.2	3.9	4.5
Row 2	0.8	1.4	1.7	1.9	2.2	2.6	3.2	3.9
Row 1	0.8	1.2	1.4	1.6	1.9	2.3	2.9	3.6
Row 0	0.7	1.0	1.1	1.3	1.6	2.0	2.6	3.3
	0.5	0.6	0.8	1.0	1.3	1.6	2.3	3.0
	0.2	0.3	0.5	0.7	1.0	1.3	2.0	2.7
	A	B	C	D	E	F	G	H

09800006

CC2602 Coolant Test Kit

- Works with any SCA formulation (Call 1-800-521-4005 if you have this test kit and the color chart does not show the number of units of SCA per gallon of coolant).

Probablizer:

3318169S Plug

- Installs on the engine for easy coolant sampling

3318168S Cap

- Use with Monitor C bottle to sample coolant

CC2700 Monitor C

- Lab analysis of coolant samples

Call the following numbers to get answers to any questions you may have about cooling system maintenance.

Cummins: 1-800-DIESELS
1-800-521-4005

1-800-22-FILTERS
1 - 800 - 223 - 4583

00200003

Coolant Replacement Requirements

Drain and flush the cooling system after 6,000 hours, or 2 years of service. Refill with either new **fully formulated coolant** or a 50/50 mixture of good quality water and fully formulated antifreeze, and install the correct service coolant filter.

NOTE: If the coolant is **not** going to be reused, dispose of used coolant/antifreeze in accordance with federal, state, and local laws and regulations.

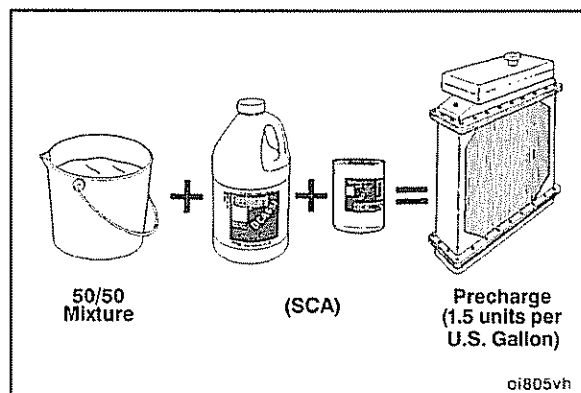

Drive Belt Tension

SAE Belt Size	Belt Tension Gauge Part No.		Belt Tension New		Belt Tension Range Used*	
	Click-type	Burroughs	N	lbf	N	lbf
0.380 in	3822524		620	140	270 to 490	60 to 110
0.440 in	3822524		620	140	270 to 490	60 to 110
1/2 in	3822524	ST-1138	620	140	270 to 490	60 to 110
11/16 in	3822524	ST-1138	620	140	270 to 490	60 to 110
3/4 in	3822524	ST-1138	620	140	270 to 490	60 to 110
7/8 in	3822524	ST-1138	620	140	270 to 490	60 to 110
4 rib	3822524	ST-1138	620	140	270 to 490	60 to 110
5 rib	3822524	ST-1138	670	150	270 to 530	60 to 120
6 rib	3822525	ST-1293	710	160	290 to 580	65 to 130
8 rib	3822525	ST-1293	890	200	360 to 710	80 to 160
10 rib	3822525	3823138	1110	250	440 to 890	100 to 200
12 rib	3822525	3823138	1330	300	530 to 1070	120 to 240
12 rib K section	3822525	3823138	1330	300	890 to 1070	200 to 240

NOTE: This chart does not apply to automatic belt tensioners.

- * A belt is considered used if it has been in service for ten minutes or longer.
- * If used belt tension is less than the minimum value, tighten the belt to the maximum used belt value.

Engine Component Torque Values

Component	Wrench Size	Torque Value	
		N•m	ft-lb
Oil Pan Drain Plug	1-1/4	88	65
Turbocharger Mounting Nuts	16 mm	68	50
Air Compressor Unloader Valve Capscrews	1/2 in.	14	10
Fan Drive Idler Pulley Shaft Locknut		165 to 190	120 to 140
Injector Adjusting Screw Locknut W/Adapter, Part No. ST-669	3/4 in	61	45
Injector/Valve Adjusting Screw Locknut Without Adapter, Part No. ST-669	3/4 in.	47	35
Engine Brake Adjusting Screw Locknut W/Adapter, Part No. ST-669		50	40
Engine Brake Adjusting Screw Locknut Without Adapter, Part No. ST-669		47	35
Fuel Pump Mounting Capscrews	7/16 in	47	35
Fuel Pump Bracket to Cylinder Block Bracket		45	35
Fuel Pump Bracket to Fuel Pump Housing	7/16 in	11	95 in-lb
Rocker Lever Cover Capscrews	13 mm	15	130 in-lb
Injector Holddown Clamps		75	55



Arctic Operation

⚠ CAUTION ⚠

The use of a synthetic base oil does not justify extended oil change intervals. Extended oil change intervals can decrease engine life due to factors such as corrosion, deposits, and wear.

If an engine is operated in ambient temperatures consistently below -23°C [-10°F] and there are no provisions to keep the engine warm when it is **not** in operation, use a synthetic CE/SF engine oil with adequate low temperature properties such as 5W-20 or 5W-30.

The oil supplier **must** be responsible for meeting the performance service specifications

Capscrew Markings and Torque Values



When replacing capscrews, always use a capscrew of the same measurement and strength as the capscrew being replaced. Using the wrong capscrews can result in engine damage.

Metric capscrews and nuts are identified by the grade number stamped on the head of the capscrew or on the surface of the nuts. U.S. Customary capscrews are identified by radial lines stamped on the head of the capscrew.

The following examples indicate how capscrews are identified:

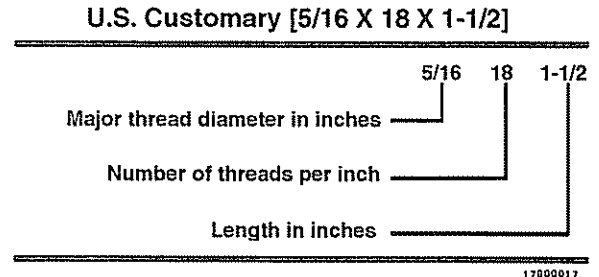
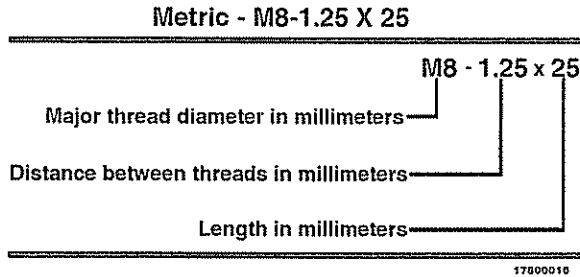

NOTES:

1. **Always** use the torque values listed in the following tables when specific torque values are **not** available.
2. Do **not** use the torque values in place of those specified in other sections of this manual.
3. The torque values in the table are based on the use of lubricated threads.
4. When the ft-lb value is less than 10, convert the ft-lb value to in-lb to obtain a better torque with an in-lb torque wrench. Example: 6 ft-lb equals 72 in-lb.



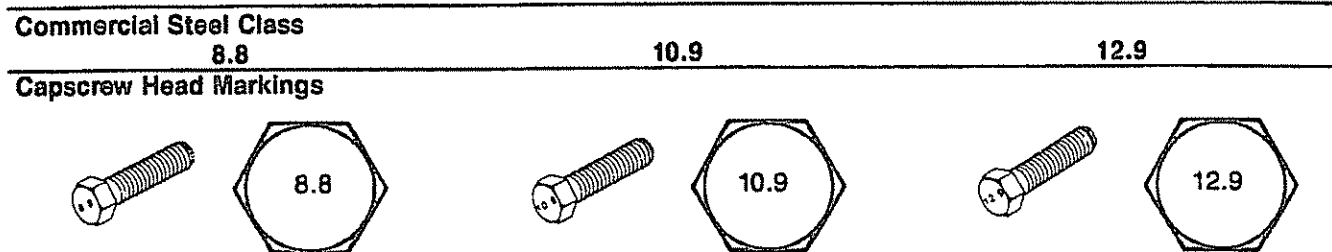

Capscrew Markings and Torque Values — Metric

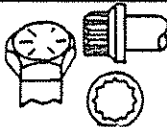

Body Size	Torque				Torque				Torque			
	Cast Iron		Aluminum		Cast Iron		Aluminum		Cast Iron		Aluminum	
	Diam.				Diam.				Diam.			
mm	N•m	ft-lb	N•m	ft-lb	N•m	ft-lb	N•m	ft-lb	N•m	ft-lb	N•m	ft-lb
6	9	5	7	4	12	9	7	4	14	9	7	4
7	14	9	11	7	18	14	11	7	23	18	11	7
8	25	18	18	14	33	25	18	14	40	29	18	14
10	45	33	30	25	60	45	30	25	70	50	30	25
12	80	60	55	40	105	75	55	40	125	95	55	40
14	125	90	90	65	165	122	90	65	195	145	90	65
16	180	130	140	100	240	175	140	100	290	210	140	100
18	230	170	180	135	320	240	180	135	400	290	180	135

Capscrew Markings and Torque Values — U.S. Customary

SAE Grade Number	5	8
Capscrew Head Markings These are all SAE Grade 5 (3) line		
		
	Capscrew Torque - Grade 5 Capscrew	Capscrew Torque - Grade 8 Capscrew

Capscrew Body Size	Cast Iron		Aluminum		Cast Iron		Aluminum	
	N•m	ft-lb	N•m	ft-lb	N•m	ft-lb	N•m	ft-lb
1/4 - 20	9	7	8	6	15	11	8	6
- 28	12	9	9	7	18	13	9	7
5/16 - 18	20	15	16	12	30	22	16	12
- 24	23	17	19	14	33	24	19	14
3/8 - 16	40	30	25	20	55	40	25	20
- 24	40	30	35	25	60	45	35	25
7/16 - 14	60	45	45	35	90	65	45	35
- 20	65	50	55	40	95	70	55	40
1/2 - 13	95	70	75	55	130	95	75	55
- 20	100	75	80	60	150	110	80	60
9/16 - 12	135	100	110	80	190	140	110	80
- 18	150	110	115	85	210	155	115	85
5/8 - 11	180	135	150	110	255	190	150	110
- 18	210	155	160	120	290	215	160	120
3/4 - 10	325	240	255	190	460	340	255	190
- 16	365	270	285	210	515	380	285	210
7/8 - 9	490	360	380	280	745	550	380	280
- 14	530	390	420	310	825	610	420	310
1 - 8	720	530	570	420	1100	820	570	420
- 14	800	590	650	480	1200	890	650	480

Section W - Warranty

Section Contents

	Page
California Emission Control System Warranty Statement	W-6
Cummins Warranty - International Industrial	W-1
Cummins Warranty - United States and Canada Industrial	W-3



THIS PAGE LEFT INTENTIONALLY BLANK.

Cummins Warranty - International Industrial

Coverage

PRODUCTS WARRANTED

This warranty applies to new Engines sold by Cummins Engine Company, Inc., hereinafter 'Cummins', and delivered to the first user on or after February 1, 1993, that are used in industrial (off-highway) applications anywhere in the world where Cummins-approved service is available, except the United States* and Canada. Different warranty coverage is provided for Engines used in marine, generator drive and certain defense applications.

BASE ENGINE WARRANTY

This warranty covers any failures of the Engine, under normal use and service, which result from a defect in material or factory workmanship (Warrantable Failure).

Coverage begins with the sale of the Engine by Cummins. Coverage continues for two years or 2,000 hours of operation, whichever occurs first, from the date of delivery of the Engine to the first user, or from the date the unit is first leased, rented or loaned, or when the Engine has been operated for 50 hours, whichever occurs first. If the 2,000 hour limit is exceeded during the first year, coverage continues until the end of the first year.

EXTENDED MAJOR COMPONENTS WARRANTY

The Extended Major Components Warranty covers Warrantable Failures of the Engine cylinder block, camshaft, crankshaft and connecting rods (Covered Parts).

Bushing and bearing failures are not covered.

This coverage begins with the expiration of the Base Engine Warranty and ends three years or 10,000 hours of operation, after the date of delivery of the Engine to the first user, or from the date the unit is first leased, rented or loaned, or from when the Engine has been operated for 50 hours, whichever occurs first.

These warranties are made to all Owners in the chain of distribution, and Coverage continues to all subsequent Owners until the end of the periods of Coverage.

Cummins Responsibilities

DURING THE BASE ENGINE WARRANTY

Cummins will pay for all parts and labor needed to repair the damage to the Engine resulting from a Warrantable Failure.

Cummins will pay for the lubricating oil, antifreeze, filter elements, and other maintenance items that are not reusable due to a Warrantable Failure.

Cummins will pay reasonable costs for mechanics to travel to and from the equipment site, including meals, mileage and lodging, when the repair is performed at the site of the failure.

Cummins will pay reasonable labor costs for Engine removal and reinstallation when necessary to repair a Warrantable Failure.

DURING THE EXTENDED MAJOR COMPONENTS WARRANTY

Cummins will pay for the repair or, at its option, replacement of the defective Covered Part and any Covered Part damaged by a Warrantable Failure of the defective Covered part.

Owners Responsibilities

DURING THE BASE ENGINE WARRANTY

Owner is responsible for the cost of lubricating oil, antifreeze, filter elements and other maintenance items replaced during warranty repairs unless such items are not reusable due to the Warrantable Failure.

DURING THE EXTENDED MAJOR COMPONENTS WARRANTY

Owner is responsible for the cost of all labor needed to repair the Engine, including the labor to remove and reinstall the Engine. When Cummins elects to repair a part instead of replacing it, Owner is not responsible for the labor needed to repair the part.

Owner is responsible for the cost of all parts required for the repair except for the defective Covered Part and any Covered Part damaged by a Warrantable Failure of the defective Covered Part.

Owner is responsible for the cost of lubricating oil, antifreeze, filter elements and other maintenance items replaced during repair of a Warrantable Failure.

DURING THE BASE ENGINE AND EXTENDED MAJOR COMPONENTS WARRANTIES

Owner is responsible for the operation and maintenance of the Engine as specified in the applicable Cummins Operation and Maintenance Manual. Owner is also responsible for providing proof that all recommended maintenance has been performed.

Before the expiration of the applicable warranty, Owner must notify a Cummins distributor, authorized dealer or other repair location approved by Cummins of any Warrantable Failure and make the product available for repair by such facility. Locations are listed in the Cummins International Sales and Service Directory.

Owner is responsible for communication expenses, meals, lodging and similar costs incurred as a result of a Warrantable Failure.

Owner is responsible for non-Engine repairs, "downtime" expenses, cargo damage, fines, all applicable taxes, all business costs and other losses resulting from a Warrantable Failure.

Limitations

Cummins is not responsible for failures or damage resulting from what Cummins determines to be abuse or neglect, including, but not limited to: operation without adequate coolants or lubricants; overfueling; overspeeding; lack of maintenance of lubricating, cooling or intake systems; improper storage, starting, warm-up, run-in or shutdown practices; unauthorized modifications of the Engine. Cummins is also not responsible for failures caused by incorrect oil or fuel or by water, dirt or other contaminants in the fuel or oil.

Accessories, except for clutches and filters, supplied by Cummins as part of a fire pump or power unit (package units) are covered for the duration of the Base Engine Warranty period.

Starters, alternators, power steering pumps and non-Cummins air compressors supplied by Cummins on B or C Series Engines that are not supplied as part of a package unit are covered for six months from the date of delivery of the Engine to the first user, or the date the Engine is first leased, rented or loaned, or from when the Engine has been operated for 50 hours, whichever occurs first.

Except for the accessories noted previously, Cummins does not warrant accessories which bear the name of another company. Such non-warranted accessories include, but are not limited to: fans, air conditioning compressors, clutches, filters, transmissions, torque converters, steering pumps, non-Cummins fan drives, and air cleaners.

Cummins Compusave units are covered by a separate warranty.

Before a claim for excessive oil consumption will be considered, Owner must submit adequate documentation to show that consumption exceeds Cummins published standards.

Failures of belts and hoses supplied by Cummins are not covered beyond the first 500 hours or one year of operation, whichever occurs first.

Parts used to repair a Warrantable Failure may be new Cummins parts, Cummins approved rebuilt parts, or repaired parts. Cummins is not responsible for failures resulting from the use of parts not approved by Cummins.

A new Cummins or Cummins-approved rebuilt part used to repair a Warrantable Failure assumes the identity of the part it replaced and is entitled to the remaining coverage hereunder.

CUMMINS DOES NOT COVER WEAR OR WEAROUT OF COVERED PARTS.

CUMMINS IS NOT RESPONSIBLE FOR INCIDENTAL OR CONSEQUENTIAL DAMAGES.

THESE WARRANTIES SET FORTH HEREIN ARE THE SOLE WARRANTIES MADE BY CUMMINS IN REGARD TO THESE ENGINES. CUMMINS MAKES NO OTHER WARRANTIES, EXPRESS OR IMPLIED, OR OF MERCHANTABILITY OR FITNESS FOR A PARTICULAR PURPOSE.

In case of consumer sales, in some countries, the Owner has statutory rights which cannot be affected or limited by the terms of this warranty.

Nothing in this warranty excludes or restricts any contractual rights the Owner may have against third parties.

Cummins Warranty - United States and Canada Industrial

Coverage

PRODUCTS WARRANTED

This warranty applies to new Engines sold by Cummins Engine Company, Inc., hereinafter 'Cummins', and delivered to the first user on or after February 1, 1993, that are used in industrial (off-highway) applications in the United States* and Canada, except for Engines used in marine, generator drive and certain defense applications, for which different warranty coverage is provided.

BASE ENGINE WARRANTY

This warranty covers any failures of the Engine, under normal use and service, which result from a defect in material or factory workmanship (Warrantable Failure).

Coverage begins with the sale of the Engine by Cummins. Coverage continues for two years or 2,000 hours of operation, whichever occurs first, from the date of delivery of the Engine to the first user, or from the date the unit is first leased, rented or loaned, or when the Engine has been operated for 50 hours, whichever occurs first. If the 2,000 hour limit is exceeded during the first year, coverage continues until the end of the first year.

EXTENDED MAJOR COMPONENTS WARRANTY

The Extended Major Components Warranty covers Warrantable Failures of the Engine cylinder block, camshaft, crankshaft and connecting rods (Covered Parts).

Bushing and bearing failures are not covered.

This coverage begins with the expiration of the Base Engine Warranty and ends three years or 10,000 hours of operation from the date of delivery of the Engine to the first user, or from the date the unit is first leased, rented or loaned, or from when the Engine has been operated for 50 hours, whichever occurs first.

CONSUMER PRODUCTS

The warranty on Consumer Products in the United States is a LIMITED warranty. **CUMMINS IS NOT RESPONSIBLE FOR INCIDENTAL OR CONSEQUENTIAL DAMAGES.** Any implied warranties applicable to Consumer Products in the United States terminate concurrently with the expiration of the express warranties applicable to the product. In the United States, some states do not allow the exclusion of incidental or consequential damages, or limitations on how long an implied warranty lasts, so the limitations or exclusions herein may not apply to you.

These warranties are made to all Owners in the chain of distribution, and Coverage continues to all subsequent Owners until the end of the periods of Coverage.

Cummins Responsibilities

DURING THE BASE ENGINE WARRANTY

Cummins will pay for all parts and labor needed to repair the damage to the Engine resulting from a Warrantable Failure.

Cummins will pay for the lubricating oil, antifreeze, filter elements, and other maintenance items that are not reusable due to the Warrantable Failure.

Cummins will pay reasonable costs for mechanics to travel to and from the equipment site, including meals, mileage and lodging, when the repair is performed at the site of the failure.

Cummins will pay reasonable labor costs for Engine removal and reinstallation when necessary to repair a Warrantable Failure.

DURING THE EXTENDED MAJOR COMPONENTS WARRANTY

Cummins will pay for the repair or, at its option, replacement of the defective Covered Part and any Covered Part damaged by a Warrantable Failure of the defective Covered part.

Owners Responsibilities

DURING THE BASE ENGINE WARRANTY

Owner is responsible for the cost of lubricating oil, antifreeze, filter elements and other maintenance items provided during warranty repairs unless such items are not reusable due to the Warrantable Failure.

DURING THE EXTENDED MAJOR COMPONENTS WARRANTY

Owner is responsible for the cost of all labor needed to repair the Engine, including the labor to remove and reinstall the Engine. When Cummins elects to repair a part instead of replacing it, Owner is not responsible for the labor needed to repair the part.

Owner is responsible for the cost of all parts required for the repair except for the defective Covered Part and any Covered Part damaged by a Warrantable Failure of the defective Covered Part.

Owner is responsible for the cost of lubricating oil, antifreeze, filter elements and other maintenance items replaced during repair of a Warrantable Failure.

DURING THE BASE ENGINE AND EXTENDED MAJOR COMPONENTS WARRANTIES

Owner is responsible for the operation and maintenance of the Engine as specified in the applicable Cummins Operation and Maintenance Manual. Owner is also responsible for providing proof that all recommended maintenance has been performed.

Before the expiration of the applicable warranty, Owner must notify a Cummins distributor, authorized dealer or other repair location approved by Cummins of any Warrantable Failure and make the Engine available for repair by such facility. Locations in the United States and Canada are listed in the Cummins Off Highway Authorized Dealer Directory.

Owner is responsible for communication expenses, meals, lodging and similar costs incurred as a result of a Warrantable Failure.

Owner is responsible for non-Engine repairs, "downtime" expenses, cargo damage, fines, all applicable taxes, all business costs and other losses resulting from a Warrantable Failure.

Limitations

Cummins is not responsible for failures or damage resulting from what Cummins determines to be abuse or neglect, including, but not limited to: operation without adequate coolants or lubricants; overfueling; overspeeding; lack of maintenance of lubricating, cooling or intake systems; improper storage, starting, warm-up, run-in or shutdown practices; unauthorized modifications of the Engine. Cummins is also not responsible for failures caused by incorrect oil or fuel or by water, dirt or other contaminants in the fuel or oil.

For power units and fire pumps (package units), this warranty applies to accessories, except for clutches and filters, supplied by Cummins which bear the name of another company.

Except for power units and fire pumps, this warranty does not apply to accessories which bear the name of another company. Such non-warranted accessories include, but are not limited to: alternators, starters, fans, air conditioning compressors, clutches, filters, transmissions, torque converters, steering pumps, and non-Cummins fan drives, engine compression brakes and air compressors.

Cummins Compusave units are covered by a separate warranty.

Before a claim for excessive oil consumption will be considered, Owner must submit adequate documentation to show that consumption exceeds Cummins published standards.

Failures of belts and hoses supplied by Cummins are not covered beyond the first 500 hours or one year of operation, whichever occurs first.

Parts used to repair a Warrantable Failure may be new Cummins parts, Cummins approved rebuilt parts, or repaired parts. Cummins is not responsible for failures resulting from the use of parts not approved by Cummins.

A new Cummins or Cummins-approved rebuilt part used to repair a Warrantable Failure assumes the identity of the part it replaced and is entitled to the remaining coverage hereunder.

CUMMINS DOES NOT COVER WEAR OR WEAROUT OF COVERED PARTS.

CUMMINS IS NOT RESPONSIBLE FOR INCIDENTAL OR CONSEQUENTIAL DAMAGES.

THESE WARRANTIES SET FORTH HEREIN ARE THE SOLE WARRANTIES MADE BY CUMMINS IN REGARD TO THESE ENGINES. CUMMINS MAKES NO OTHER WARRANTIES, EXPRESS OR IMPLIED, OR OF MERCHANTABILITY OR FITNESS FOR A PARTICULAR PURPOSE.

This warranty gives you specific legal rights, and you may also have other rights which vary from state to state.

Emission Warranty

Products Warranted

This emission warranty applies to new Engines marketed by Cummins that are used in the United States* in vehicles designed for Industrial off-highway use. This warranty applies to Engines delivered to the ultimate purchaser on or after January 1, 1996.

Coverage

Cummins warrants to the ultimate purchaser and each subsequent purchaser that the Engine is designed, built and equipped so as to conform at the time of sale by Cummins with all U.S. Federal emission regulations applicable at the time of manufacture and that it is free from defects in workmanship or material which would cause it not to meet these regulations within the longer of the following periods: (A) Five years or 3,000 hours of operation, whichever occurs first, as measured from the date of delivery of the Engine to the ultimate purchaser, or (B) The Base Engine Warranty.

If the vehicle in which the Engine is installed is registered in the state of California, a separate California Emission Warranty also applies.

Limitations

Failures, other than those resulting from defects in materials, or workmanship, are not covered by this warranty.

Cummins is not responsible for failures or damage resulting from what Cummins determines to be abuse or neglect, including, but not limited to: operation without adequate coolant or lubricants; overfueling; overspeeding; lack of maintenance of lubricating, cooling or intake systems; improper storage, starting, warm-up, run-in or shutdown practices; unauthorized modifications of the Engine. Cummins is also not responsible for failures caused by incorrect fuel or by water, dirt or other contaminants in the fuel.

Cummins is not responsible for non-Engine repairs, "downtime" expenses, cargo damage, fines, all business costs or other losses resulting from a Warrantable Failure.

CUMMINS IS NOT RESPONSIBLE FOR INCIDENTAL OR CONSEQUENTIAL DAMAGES.

*Includes American Samoa, the Commonwealth of Northern Mariana Islands, Guam, Puerto Rico, and the U.S. Virgin Islands.



California Emission Control System Warranty Statement

Products Warranted

This Emission Control System Warranty applies to heavy-duty off-road diesel engines certified with the California Air Resources Board beginning with the year 1996, marketed by Cummins, and registered in California for use in industrial off-highway applications.

Your Warranty Rights and Obligations

The California Air Resources Board and Cummins Engine Company, Inc., are pleased to explain the emission control system warranty on your 1996 engine. In California, new heavy-duty off-road diesel engines must be designed, built and equipped to meet the State's stringent anti-smog standards. Cummins must warrant the emission control system on your engine for the periods of time listed below provided there has been no abuse, neglect or improper maintenance of your engine.

Your emission control system may include parts such as the fuel injection system and the air induction system. Also included may be hoses, belts, connectors and other emission-related assemblies.

Where a warrantable condition exists, Cummins will repair your heavy-duty off-road diesel engine at no cost to you including diagnosis, parts and labor.

Manufacturer's Warranty Coverage

The 1996 and later heavy-duty off-road diesel engines are warranted for 5 years or 3,000 hours of engine operation, whichever first occurs from the date of delivery of the engine to the first user. If any emission-related part on your engine is defective, the part will be repaired or replaced by Cummins.

Coverage

This emission control system warranty applies only to the following M11 and N14 emission control parts:

Fuel Pump

AFC Plunger
AFC Spring
AFC/ASA Valve
AFC Setting
Throttle Shaft
No Air Setting
Static Timing

Injectors (STC)

Cup
Calibration
Top Stop
Spring
Spring Retainer
Sleeve
Check Ball Spring
Retainer Clip

Turbocharger

Compressor Wheel
Turbine Wheel
Turbine Oil Seal

Intake Manifold

Charge Air Cooler
Aftercooler

Exhaust Manifold

Oil Control Valve (STC)

Plunger
Spring
Oil Transfer Connection
Assembly

Injectors (CELECT™)

Body
Cup
Needle
Nozzle Spring
Barrel

Electronic Control System

Control Module
Boost Pressure Sensor
Coolant Temperature Sensor

Owner's Warranty Responsibilities

As the heavy-duty off-road diesel engine owner, you are responsible for the performance of the required maintenance listed in your Cummins Operation and Maintenance Manual. Cummins recommends that you retain all receipts covering maintenance on your heavy-duty off-road diesel engine, but Cummins cannot deny warranty solely for the lack of receipts or for your failure to ensure the performance of all scheduled maintenance.

You are responsible for presenting your heavy-duty off-road diesel engine to a Cummins dealer as soon as a problem exists. The warranty repairs should be completed in a reasonable amount of time, not to exceed 30 days.

As the heavy-duty off-road diesel engine owner, you should also be aware that Cummins may deny you warranty coverage if your heavy-duty off-road diesel engine or a part has failed due to abuse, neglect, improper maintenance or unapproved modifications.

Your engine is designed to operate on diesel fuel only. Use of any other fuel may result in your engine no longer operating in compliance with California's emissions requirements.

If you have any questions regarding your warranty rights and responsibilities, you should contact Cummins Customer Relation Department at 1-800-343-7357 or the California Air Resources Board at 9528 Telstar Avenue, El Monte, CA 91731.

Prior to the expiration of the applicable warranty, Owner must give notice of any warranted emission control failure to a Cummins distributor, authorized dealer or other repair location approved by Cummins and deliver the engine to such facility for repair. Repair locations are listed in Cummins United States and Canada Service Directory.

Owner is responsible for incidental costs such as: communication expenses, meals, lodging incurred by Owner or employees of Owner as a result of a warrantable failure.

Owner is responsible for business costs and losses, "downtime" expenses, and cargo damage resulting from a warrantable failure. CUMMINS IS NOT RESPONSIBLE FOR OTHER INCIDENTAL OR CONSEQUENTIAL DAMAGES, INCIDENTAL OR CONSEQUENTIAL DAMAGES INCLUDE BUT ARE NOT LIMITED TO FINES, THEFT, VANDALISM OR COLLISIONS.

Replacement Parts

Cummins recommends that any service parts used for maintenance, repair or replacement of emission control systems be new, genuine Cummins or Cummins approved rebuilt parts and assemblies, and that the engine be serviced by a Cummins distributor, authorized dealer or the repair location approved by Cummins. The owner may elect to have maintenance, replacement or repair of the emission control parts performed by a facility other than a Cummins distributor, an authorized dealer or a repair location approved by Cummins, and may elect to use parts other than new genuine Cummins or Cummins approved rebuilt parts and assemblies for such maintenance, replacement or repair; however, the cost of such service or parts will not be covered under this emission control system warranty.

Cummins Responsibilities

Repairs and service will be performed by any Cummins distributor, authorized dealer or other repair location approved by Cummins using new, genuine Cummins or Cummins approved rebuilt parts and assemblies. Cummins will repair any of the emission control parts found by Cummins to be defective without charge for parts or labor (including diagnosis which results in determination that there has been a failure of a warranted emission control part).

Emergency Repairs

In the case of an emergency where a Cummins distributor, authorized dealer, or other repair location approved by Cummins is not available, repairs may be performed by any available repair location using any replacement parts. Cummins will reimburse the Owner for expenses (including diagnosis), not to exceed the manufacturer's suggested retail price for all warranted parts replaced and labor charges based on the manufacturer's recommended time allowance for the warranty repair and the geographically appropriate hourly labor rate. A part not being available within 30 days or a repair not being complete within 30 days constitutes an emergency. Replaced parts and paid invoices must be presented at a Cummins authorized repair facility as a condition of reimbursement for emergency repairs not performed by a Cummins distributor, authorized dealer, or other repair location approved by Cummins.

Warranty Limitations

Cummins is not responsible for failures resulting from Owner or operator abuse or neglect, such as: operation without adequate coolant, fuel or lubricants; overfueling; overspeeding; lack of maintenance of lubricating, cooling or air intake systems; improper storage, starting, warm-up, run-in or shutdown practices.

The manufacturer warrants to the ultimate purchaser and each subsequent purchaser that the engine is designed, built, and equipped so as to conform with all applicable regulations adopted by the Air Resources Board, and that it is free from defects in materials and workmanship which cause the failure of a warranted part.

Any warranted part which is not scheduled for replacement as required maintenance, or which is scheduled only for regular inspection to the effect of "repair or replace as necessary" is warranted for the warranty period.

Any warranted part which is scheduled for replacement as required maintenance is warranted for the period of time prior to the first scheduled replacement point for that part.

The owner will not be charged for diagnostic labor which leads to the determination that a warranted part is defective, if the diagnostic work is performed at a warranty station.

The manufacturer is liable for damages to other engine components caused by the failure under warranty of any warranted part.

Cummins is not responsible for failures resulting from improper repair or the use of parts which are not genuine Cummins or Cummins approved parts.

These warranties, together with the express commercial warranties and emission warranty are the sole warranties of Cummins. There are no other warranties, express or implied, or of merchantability or fitness for a particular purpose.

About the Manual	i-1	Fleetguard® DCA4 Service Filters and Liquid Precharge	V-13
Acronyms and Abbreviations	i-8	Fully Formulated Coolant/Antifreeze	V-10
Additional Service Literature	L-1	Supplemental Coolant Additive (SCA)	V-14
Air Cleaner Element, Cartridge Type	4-4	Test Intervals	V-16
Maintenance Check	4-4	Testing SCA Concentration Level CC-2602 Test Kit	V-15
Air Cleaner Element, Dual Heavy Duty Dry Type	4-3	Precautions and Instructions for Proper Kit Use	V-15
Maintenance Check	4-3	Coolant Thermostat	A-10
Air Cleaner Element, Paper Type	4-1	Install	A-11
Maintenance Check	4-1	Remove	A-10
Air Cleaner Element, Single Heavy Duty Dry Type	4-2	Cooling System	7-1
Maintenance Check	4-2	Clean	7-1
Air Cleaner Restriction	4-1	Maintenance Check	7-3
Maintenance Check	4-1	Antifreeze	7-3
Air Compressor Air Cleaner Element	5-9	Crankcase Breather Tube	3-5
Maintenance Service	5-9	Maintenance Check	3-5
Air Compressor Maintenance	8-11	Cummins Warranty - International Industrial	W-1
Maintenance Check	8-11	Cummins Warranty - United States and Canada Industrial ...	W-3
Air Compressor Discharge — Inspect	8-11	Daily Maintenance Procedures - General Information	3-1
Air Compressor Intake — Inspect	8-13	Drive Belt, Alternator	A-2
Air Leaks, Air Intake System	4-5	Adjust	A-2
Maintenance Check	4-5	Install	A-4
Air Starting Motor	A-19	Remove	A-3
Air Tanks and Reservoirs	4-7	Drive Belt, Cooling Fan	A-1
Drain	4-7	Adjust	A-1
Arctic Operation	V-20	Install	A-2
California Emission Control System Warranty Statement	W-6	Remove	A-1
Capscrew Markings and Torque Values	V-21	Drive Belt Tension	V-18
Capscrew Markings and Torque Values — Metric	V-22	Drive Belts	3-5
Capscrew Markings and Torque Values — U.S. Customary ..	V-23	Maintenance Check	3-5
Cold Weather Operation	1-7	Engine Component Torque Values	V-19
Shutters	1-9	Engine Diagrams	E-4
Thermo Control Settings	1-8	Engine Identification	E-1
Winterfronts	1-9	Cummins Engine Nomenclature	E-1
Cold Weather Starting Using Starting Fluid	1-4	Engine Dataplate	E-1
With Mechanical or Electrical Metering Equipment (Ether)	1-4	Fuel Pump Dataplate	E-1
Component Manufacturers' Addresses	M-1	Engine Mounting Bolts	6-9
Air Compressors	M-1	Maintenance Check	6-9
Air Cylinders	M-1	Engine Operating Range	1-6
Air Heaters	M-1	Engine Operation Report	3-1
Air Starting Motors	M-1	Engine Shutdown	1-9
Alternators	M-1	Engine Steam Cleaning	6-9
Auxiliary Brakes	M-1	Clean	6-9
Belts	M-1	Engine Storage - Long Term	A-19
Catalytic Convertors	M-1	Fan, Cooling	3-4
Clutches	M-1	Inspect for Reuse	3-4
Coolant Heaters	M-2	Fan Drive Idler Pulley Assembly	A-12
Coolant Level Switches	M-1	Install	A-13
Drive Plates	M-2	Maintenance Check	8-8
Electric Starting Motors	M-2	Remove	A-12
Electronic Switches	M-2	Fan Hub, Belt Driven	A-14
Engine Protection Controls	M-2	Install	A-15
Fan Clutches	M-2	Maintenance Check	8-9
Fans	M-2	Remove	A-14
Fault Lamps	M-2	Flow Diagram, Air Intake System	D-5
Filters	M-2	Flow Diagram	D-5
Flexplates	M-2	Flow Diagram, Compressed Air System	D-7
Fuel Coolers	M-2	Flow Diagram	D-7
Fuel Warmers	M-2	Flow Diagram, Cooling System	D-4
Gauges	M-2	Flow Diagram	D-4
Governors	M-3	Flow Diagram, Exhaust System	D-6
Heat Sleeves	M-3	Flow Diagram	D-6
Hydraulic and Power Steering Pumps	M-3	Flow Diagram, Fuel System	D-2
In-Line Connectors	M-3	Flow Diagram	D-2
Oil Heaters	M-3	Flow Diagram, Lubricating Oil System	D-3
Prelubrication Systems	M-3	Flow Diagram	D-3
Radiators	M-3	Fuel Filter (Spin-On Type)	5-1
Throttle Assemblies	M-3	Install	5-1
Torque Converters	M-3	Fuel-Water Separator (Superfilter)	5-1
Coolant Filter	5-7	Remove	5-1
Install	5-7	Fuel Pump	8-5
Remove	5-7	Install	8-7
Coolant Level	3-2	STC	8-7
Maintenance Check	3-2	Remove	8-5
Coolant Recommendations and Specifications	V-10	STC	8-5
Coolant Replacement Requirements	V-17	Fuel Recommendations and Specifications	V-6
Cooling System Sealing Additives	V-12	Fuel-Water Separator	3-2
Cooling System Soluble Oils	V-12	Drain	3-2

Index
Page X-2

General Safety Instructions	i-7	SYMPTOM: Alternator Not Charging or Insufficient Charging	TS-7
Important Safety Notice	i-7	SYMPTOM: Coolant Loss — External	TS-8
How to Use the Manual	i-1	SYMPTOM: Coolant Temperature Above Normal —	
Illustrations	i-6	Gradual Overheat	TS-9
Injector	8-1	SYMPTOM: Coolant Temperature Above Normal —	
Install	8-3	Sudden Overheat	TS-11
STC	8-3	SYMPTOM: Coolant Temperature Below Normal	TS-12
Remove	8-1	SYMPTOM: Crankcase Gases (Blowby) — Excessive	TS-13
STC	8-1	SYMPTOM: Engine Acceleration and Response Poor	TS-14
Literature Order Form	L-3	SYMPTOM: Engine Cranks But Will Not Start	
Lubricating Oil and Filters	5-2	(No Smoke From Exhaust)	TS-15
Cummins/Fleetguard® Filter Specifications	5-4	SYMPTOM: Engine Decelerates Slowly	TS-16
Lubricating Oil Filters	5-4	SYMPTOM: Engine Difficult to Start or Will Not	
Drain	5-2	Start — Exhaust Smoke Present	TS-17
Fill	5-5	SYMPTOM: Engine Noise Excessive	TS-18
Lubricating Oil Level	3-2	SYMPTOM: Engine Noise Excessive —	
Maintenance Check	3-2	Combustion Knocks	TS-19
Lubricating Oil Recommendations and Specifications	V-7	SYMPTOM: Engine Power Output Low	TS-20
General Information	V-8	SYMPTOM: Engine Runs Rough at Idle	TS-22
New Engine Break-in Oils	V-7	SYMPTOM: Engine Runs Rough or Misfires	TS-23
Arctic Operation Engine Oil	V-7	SYMPTOM: Engine Shuts Off Unexpectedly or	
Oil Drain Intervals	V-9	Dies During Deceleration	TS-24
Maintenance Guidelines - General Information	2-1	SYMPTOM: Engine Speed Surges at Low Idle	TS-25
Maintenance Procedures - General Information	5-1	SYMPTOM: Engine Speed Surges (Other Than Low Idle)	TS-26
Maintenance Record Form	2-5	SYMPTOM: Engine Starts But Will Not Keep Running	TS-27
Maintenance Schedule	2-2	SYMPTOM: Engine Vibration Excessive	TS-28
Normal Starting Procedure	1-2	SYMPTOM: Engine Will Not Crank or Cranks	
Operating Instructions - General Information	1-1	Slowly (Air Starting Motor)	TS-29
Operating the Engine	1-5	SYMPTOM: Engine Will Not Crank or Cranks	
Overhead Set	6-1	Slowly (Electric Starting Motor)	TS-30
Adjust	6-1	SYMPTOM: Engine Will Not Reach Rated	
Page References for Maintenance Instructions	2-3	Speed When Loaded	TS-31
Procedures and Techniques	TS-1	SYMPTOM: Engine Will Not Shut Off	TS-32
PTO Application with Variable Speed	1-9	SYMPTOM: Fuel Consumption — Excessive	TS-33
Radiator Shutter Assembly	6-8	SYMPTOM: Fuel in Coolant	TS-34
Maintenance Check	6-8	SYMPTOM: Fuel in the Lubricating Oil	TS-35
Service Assistance	S-1	SYMPTOM: Lubricating Oil Consumption Excessive	TS-36
Distributors - International	S-18	SYMPTOM: Lubricating Oil Contaminated	TS-37
Distributors and Branches - Australia	S-13	SYMPTOM: Lubricating Oil Pressure High	TS-38
Distributors and Branches - Canada	S-11	SYMPTOM: Lubricating Oil Pressure Low	TS-39
Distributors and Branches - New Zealand	S-14	SYMPTOM: Lubricating Oil Sludge in the	
Distributors and Branches - United States	S-4	Engine Crankcase Excessive	TS-40
Division and Regional Offices	S-3	SYMPTOM: Lubricating Oil Temperature	
Emergency and Technical Service	S-1	Above Specification	TS-41
Problem Solving	S-2	SYMPTOM: Smoke, Black — Excessive	TS-42
Regional Offices - International	S-15	SYMPTOM: Smoke, White — Excessive	TS-43
Routine Service and Parts	S-1	SYMPTOM: Turbocharger Boost Pressure Low	TS-44
Service Literature Ordering Location	L-2	SYMPTOM: Turbocharger Leaks — Engine Oil or Fuel	TS-45
Specifications	V-1	Turbocharger	A-16
Air Intake System	V-2, E-3	Install	A-17
Batteries (Specific Gravity)	V-4, E-3	Maintenance Check	6-8
Compressed Air System	V-2	Axial Clearance — Checking	8-10
Holset® SS296/SS296E/QE296 A/C Models	V-3	Radial Bearing Clearance — Checking	8-9
Holset® SS338/QE338 A/C Models	V-2	Remove	A-16
Holset® ST676 A/C Model	V-3	Vibration Damper, Single	8-1
Cooling System	V-1, E-2	Maintenance Check	8-1
Cummins/Fleetguard® Filter Specifications	V-5	Water Pump	A-4
Lubricating Oil Filters	V-5	Install	A-7
Electrical System	V-4, E-3	Maintenance Check	6-7
Exhaust System	V-2, E-3	Remove	A-4
Fuel System	V-1, E-2	Weekly Maintenance Procedures - General Information	4-1
General Specifications	V-1, E-2		
Lubricating Oil System	V-1, E-2		
Supplemental Coolant Additive (SCA)	5-8		
Maintenance Check	5-8		
Symbols	i-2		
System Diagrams - General Information	D-1		
To the Owner and Operator	i-1		
Tool Requirements	2-1		
Troubleshooting Symptoms Charts	TS-1		
SYMPTOM: Air Compressor Air Pressure Rises Slowly	TS-2		
SYMPTOM: Air Compressor Noise Excessive	TS-3		
SYMPTOM: Air Compressor Pumping Excess			
Lubricating Oil Into Air System	TS-4		
SYMPTOM: Air Compressor Will Not Maintain			
Adequate Air Pressure (Not Pumping Continuously)	TS-5		
SYMPTOM: Air Compressor Will Not Stop Pumping	TS-6		