

The "CPU"
Type
Intelligence
System

**PART 10
THE "CPU"
TYPE
INTELLIGENCE
SYSTEM**

**STANDBY
ELECTRIC
POWER
SYSTEMS**

All Series

TABLE OF CONTENTS	
SECTION	TITLE
10.1	System Familiarization
10.2	Automatic Operating Sequences
10.3	Utility Voltage Sensor Circuit Board
10.4	The CPU Circuit Board
10.5	Sensor and Timer Settings

Section 10.1 SYSTEM FAMILIARIZATION

General

The CPU type intelligence system consists of two solid state circuit boards called (a) a utility voltage sensor board and (b) the CPU board. Both circuit boards are housed in a circuit board compartment in the transfer switch enclosure door.

This system differs from the "Logic" type intelligence system in several ways. The most obvious difference is that the CPU system utilizes only two circuit boards, while the Logic system has three boards. This was accomplished by having the CPU circuit board assume the dual tasks of (a) controlling the 7-day exercise timer and (b) performing the tasks of the system control circuit board.

Another major difference between the two systems is that the "Logic" system's system control circuit board is fully programmable. The CPU circuit board does not offer this advantage but, instead, relies on fixed sensors and timers.

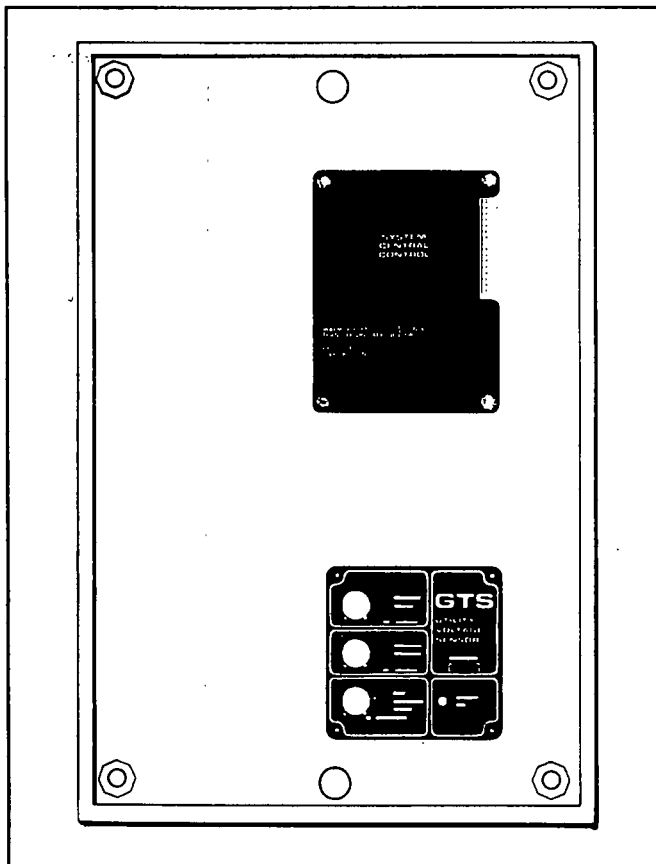

Figure 1. The Two Circuit Board (CPU) System

What the System Does

The utility voltage sensor board constantly monitors "Utility" power source voltage. Should that source voltage drop below a preset level, the utility voltage sensor board will initiate closure of the 2-wire start circuit (wires 178/183). On closure of that circuit, a DC control/latch-crank circuit board (housed in the generator console) will crank and start the engine. The sensor circuit board will also open a "utility loss sensor" circuit to the CPU board, to "tell" that board that "Utility" power has failed.

With standby generator AC output available to the transfer switch, the CPU circuit board will be turned on. The CPU board incorporates sensors and timers to control automatic operation, as follows:

- An "engine minimum run timer" on the CPU board will start timing. This timer establishes the minimum length of time the engine must run before it can be shut down in automatic mode. The timer prevents shutdown of a cold engine.
- An "engine warmup timer" starts timing. This timer provides an engine warmup period before electrical loads are transferred to the "Standby" source.
- A "standby voltage sensor" looks for an acceptable (preset) "Standby" source voltage. Transfer of loads to the "Standby" source cannot occur until that source voltage is above a preset level.
- A "standby frequency sensor" prevents transfer to the "Standby" source until that source frequency is above a preset level.
- When (a) the engine has warmed up and (b) standby voltage and frequency have reached preset levels, the CPU circuit board will energize a transfer relay. Transfer of loads to the "Standby" power supply will then occur.

NOTE: If so equipped, a time delay at neutral relay will be energized at the same time as the transfer relay. With the time delay neutral relay energized, the main contacts will trip to neutral. The main contacts will remain at "Neutral" (load disconnected from both power source sides) as long as the time delay neutral relay remains energized. A "time delay neutral timer" on the CPU board establishes the length of time the time delay neutral relay remains energized. When that timer has timed out, transfer of loads to the "Standby" side will occur.

The utility voltage sensor board continues to seek an acceptable (preset) "Utility" source voltage. On restoration of that source voltage above a preset level and for a preset time, the sensor board closes the "utility loss sensor" circuit to the CPU board. This "tells" the CPU

What the System Does (Continued)

circuit board that "Utility" source voltage has been restored.

NOTE: A "line interrupt delay timer" on the utility sensor board delays closure of the "utility loss sensor" circuit for a preset time interval. This time interval is required, to prevent retransfer that might otherwise occur as a result of transient voltages.

When the "line interrupt delay timer" times out, CPU board action will (a) de-energize the transfer relay, and (b) energize the time delay neutral relay (if so equipped). The following events will then take place:

- **Units Without Time Delay Neutral:** When the transfer relay de-energizes, "Utility" source voltage is delivered to transfer mechanism terminals and retransfer back to the "Utility" source occurs.
- **Units with Time Delay Neutral:** When the transfer relay de-energizes, the main contacts will trip to "Neutral". A "time delay neutral timer" on the CPU board will time. When that timer has timed out, the time delay neutral relay will de-energize and the main contacts will complete their travel to the "Utility" source side.

Following retransfer back to the "Utility" source, an "engine cooldown timer" on the CPU board will start timing. When that timer has timed out, circuit board action will open the 2-wire start circuit (178/183) and the generator will shut down.

The 7-Day Exercise Feature

The CPU circuit board incorporates a "7-day exercise" circuit. This feature will start the generator once every seven days (at a preset time and on a preset day). The generator will run (exercise) for a preset time interval and then shut down. During the exercise runup, transfer to the "Standby" source may or may not occur, as selected by means of a "bypass transfer on exercise" switch. The "bypass" switch is located on the CPU board.

Section 10.2

AUTOMATIC OPERATING SEQUENCES

Introduction

Timers and sensors on the CPU circuit board, used to regulate automatic operation, are fixed and non-adjustable. That is, the CPU circuit board is non-programmable.

The utility voltage sensor circuit board provides three adjustable settings as follows:

1. Voltage Pickup setting
 - a. Establishes the "Utility" source voltage required before retransfer back to that power source can occur.
 - b. Adjustment settings are given in "percent of utility" voltage.
 2. Voltage Dropout setting
 - a. Establishes the voltage dropout point at which standby generator startup and transfer to "Standby" will occur.
 - b. Adjustment settings are given in "percent of pickup voltage".
 3. Line Interrupt Delay Timer
 - a. Establishes the time delay between "Utility" voltage dropout below the "voltage dropout" setting and generator startup.
 - b. The time delay is required to prevent false generator starts that might otherwise be caused by transient voltage dips.
 - c. Adjustment settings are given in "seconds".
- e. A "Standby Operating" lamp on the switch enclosure door is OUT and operating voltage for the CPU circuit board is not available.
 2. If "Utility" source voltage drops below the setting of the utility voltage sensor board's "voltage dropout sensor", the following events will occur:
 - a. The circuit board's "Utility On" lamp (LED) goes out and the "utility loss sensor" circuit to the CPU board is opened.
 - b. The utility voltage sensor board's "line interrupt delay timer" starts timing. The timer can be set at any point between 0.1 and 10 seconds.
 - c. If voltage is still low when the timer has finished timing, the following events will occur:
 - (1) Utility voltage sensor board action will close the 2-wire start circuit (178/183).
 - (2) The generator engine will crank and start as controlled by a DC control/latch-crank circuit board in the generator console.
 3. On engine startup, the following events will occur:
 - a. A "Standby Operating" lamp on the transfer switch enclosure door illuminates.
 - b. Transformer reduced "Standby" source voltage is delivered to the CPU circuit board, which now becomes operational.
 - c. An "engine minimum run timer" on the CPU board starts timing.
 - (1) The timer is fixed at 10 minutes. That is, the engine must run for at least 10 minutes before it can be shut down in automatic mode.
 - (2) The "engine minimum run timer" prevents shut-down of a cold engine.
 - d. An "engine warmup timer", also on the CPU board, starts timing.
 - (1) "Engine warmup timer" setting is fixed at 30 seconds.
 - (2) Transfer of loads to the "Standby" power supply cannot occur until the timer has timed out.
 - e. A "standby voltage sensor" and a "standby frequency sensor" on the CPU board look for a preset, acceptable "Standby" source voltage and frequency.
 - (1) The "standby voltage" and "standby frequency" sensors are set at a fixed 80 percent of rated "Standby" source voltage and frequency.
 - (2) Transfer of the load to the "Standby" source can occur only if standby voltage and frequency are above the sensor settings.

NOTE: A special utility voltage sensor board is used on multi-voltage type transfer switches. The "multi-voltage" circuit board includes a voltage selector switch. Refer to Section 8.8.

Sequence of Automatic Operation

1. With an acceptable "Utility" source voltage sensing signal available to the utility voltage sensor board, the following conditions exist:
 - a. A "voltage dropout sensor" on the utility voltage sensor circuit board monitors the "Utility" source voltage.
 - b. A "Utility On" lamp (LED) on the utility voltage sensor board is ON.
 - c. A "Switch Position-Utility" lamp on the transfer switch enclosure door is ON.
 - d. Transformer reduced "Load" terminal voltage is delivered to the CPU circuit board, for operation of the 7-day exercise timer.

Sequence of Automatic Operation (Continued)

4. The CPU circuit board will initiate transfer to the "Standby" power supply, providing the following conditions have been met:

- a. Utility voltage sensor board must still hold the "utility loss sensor" circuit to the CPU board open. This "tells" the CPU board that "Utility" source voltage is still low.
- b. The "engine warmup timer" must have timed out.
- c. "Standby" AC voltage and frequency must be greater than 80 percent of system rated voltage and frequency.

NOTE: It must be emphasized that a transfer to "Standby" action cannot occur unless the utility voltage sensor board has opened the "utility loss sensor" circuit. That is, transfer to "Standby" cannot occur while "Utility" voltage is above the setting of the "voltage dropout sensor".

5. When all of the conditions in Sequence 4 above have been met, CPU board action will complete the transfer relay and (if so equipped) time delay relay circuits to ground.

- a. The transfer relay will energize, its normally-open contacts will close, and "Standby" source voltage will be delivered to the transfer mechanism terminals. Transfer to the "Standby" source will then occur.
- b. If so equipped, the time delay relay will energize at the same time as the transfer relay.
 - (1) Time delay relay's normally-closed contacts will open. This action will open the "Standby" voltage circuit to the transfer mechanism's "B power source side on" terminals, to prevent transfer to the "Standby" power source side.
 - (2) The transfer mechanism's main contacts will trip to "Neutral" and remain at that position as long as the time delay relay is energized.
 - (3) After five seconds, CPU board action will de-energize the time delay relay. The main contacts will then complete their movement to the "Standby" power source side.
- c. Electrical loads are now powered by the "Standby" power source.

6. The utility voltage sensor circuit board's "voltage pickup sensor" continues to seek an acceptable preset "Utility" source voltage.

- a. On restoration of "Utility" source voltage above the setting of the "voltage pickup sensor", utility voltage sensor board action closes the "utility loss sensor" circuit to the CPU board to "tell" the CPU board that "Utility" voltage has been restored.

b. A "return to utility timer" on the CPU board starts timing, will time for 30 seconds.

c. If the "utility loss sensor" circuit is still closed when the "return to utility timer" has finished timing, CPU board action will initiate the following:

(1) Circuit board action will de-energize a transfer relay. The relay's normally-closed contacts will close, to deliver "Utility" voltage to the transfer mechanism and retransfer back to the "Utility" power source will occur.

(2) If so equipped, CPU board action will energize a time delay neutral relay. The main contacts will then trip to "Neutral" and remain at "Neutral" as long as the time delay relay is energized. After five seconds, CPU board de-energizes the time delay relay and re-transfer back to the "Utility" source occurs.

7. On re-transfer back to the "Utility" side, an "engine cooldown timer" on the CPU circuit board starts timing.

- a. When the "engine cooldown timer" has finished timing, circuit board action will open the 2-wire start circuit (178/183) and engine shutdown will occur.
- b. The "engine minimum run timer" must also have timed out before engine shutdown can occur.

8. Following re-transfer back to the "Utility" source side and generator shutdown, the utility voltage sensor board continues to monitor "Utility" source voltage.

Section 10.3

UTILITY VOLTAGE SENSOR CIRCUIT BOARD

Introduction

See Figure 1. A standard utility voltage sensor board cover is shown. Note the voltage block just below the words "utility voltage sensor" on the cover. The circuit board's rated voltage must match the rated voltage of the system in which the board is used.

NOTE: Multi-voltage transfer switches use a utility voltage sensor board cover which mounts a "voltage selector switch". The switch permits a single circuit board to be used for several different rated voltage applications.

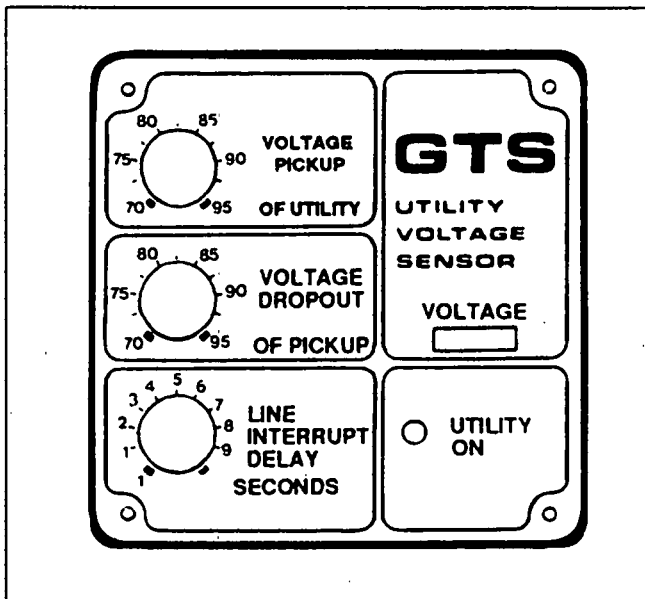

Figure 1. Utility Voltage Sensor Board Cover

Utility Voltage Sensing Connector

This 4-pin connector (Figure 2) connects the utility voltage sensor board to the utility sensing interface. Wires 224 through 227 attach to the connector. The utility sensing interface delivers a transformer reduced "Utility" sensing voltage to the circuit board via this connector. For sensing voltage inputs to the circuit board, see Test 3 on Page 8.10-2 or Test 26 on Page 9.9-10.

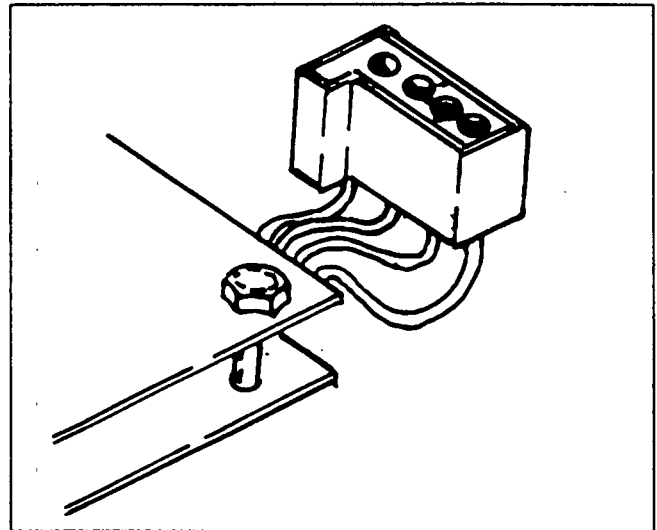

Figure 2. Utility Voltage Sensing Connector

Control System Connector

See Figure 3. Wires 177, 178, 199 and 202 attach to this connector.

Wires 177 and 178 form the 2-wire auto-start circuit. Closure of this circuit by circuit board action will occur during a "Utility" power outage, to initiate generator cranking and startup as controlled by a DC control/match-crank circuit board in the generator console.

Wires 199 and 202 (sometimes 199 and 200) are part of the "utility loss sensor" circuit which connects the utility voltage sensor board to the CPU circuit board. When "Utility" source voltage is available and above the setting of the "voltage dropout sensor", utility voltage sensor board action holds the circuit closed. However, should "Utility" voltage drop below the setting of the "voltage dropout sensor", utility voltage sensor board action will open the circuit to "tell" the CPU circuit board that "Utility" power has failed.

NOTE: Transfer to "Standby" cannot occur while the "utility loss sensor" circuit is closed.

Control System Connector (Continued)

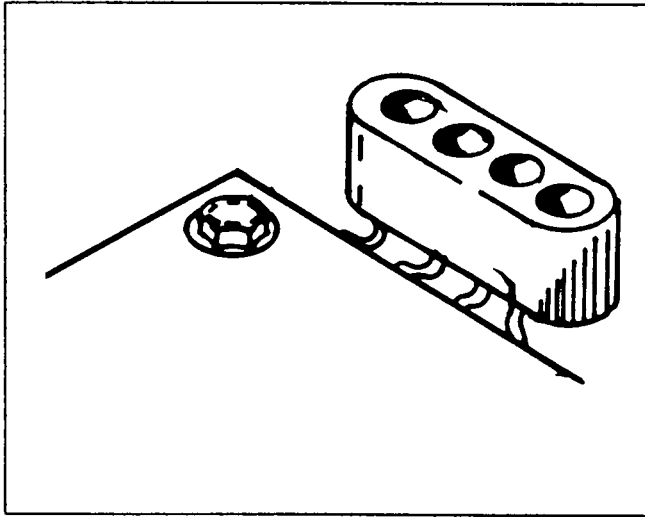

Figure 3. Control System Connector

The "Utility Loss Sensor" Circuit

Figure 4 is a simplified schematic of the "utility loss sensor" circuit. A transistor is used as a "switch", to open and close the circuit. The transistor holds the circuit closed as long as a voltage is applied to the base of the transistor. Remove the voltage that is applied to the transistor base and the circuit opens.

A voltage is applied to the transistor base as long as "Utility" source voltage is available and is above the setting of the "voltage dropout sensor". During this time, transistor action holds the "sensor" circuit closed. Wire 199 is the "high" side of the circuit, while wire 202 is the "low" (grounded) side.

When "Utility" voltage drops below the setting of the "voltage dropout sensor", circuit board action removes the voltage from the transistor base. The transistor then becomes an effective open circuit.

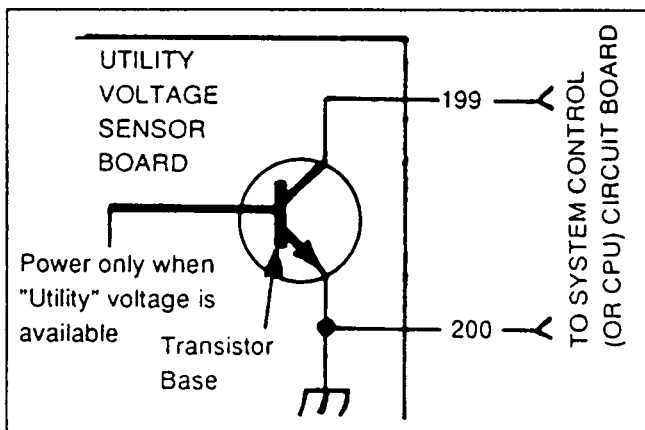

Figure 4. Schematic- Utility Loss Sensor Circuit

Circuit Board Calibration

The utility sensing interface transformers reduce the "Utility" power source voltage at a fixed ratio. Any variation in the actual "Utility" voltage supplied to the transfer switch will also result in a corresponding variation of the sensing voltage supplied to the utility voltage sensor board. For that reason, calibration of the circuit board to match the actual "Utility" source voltage may be required.

The correct procedure for calibrating the utility voltage sensor board can be found on Page 8.10-2 (Part 8, Section 8.10).

Proper calibration of the circuit board will establish the actual voltage present at the time of calibration as 100 percent, for "pickup" and "dropout" settings.

CAUTION: The installed transfer switch and the utility voltage sensor board must be rated at a voltage and phase that is compatible with the rated "Utility" and "Standby" system voltages. Do NOT attempt to calibrate a non-compatible circuit board in an attempt to make a non-compatible unit match the system voltages.

Section 10.4 THE CPU CIRCUIT BOARD

Introduction

Called the CPU or "central processing unit", this circuit board incorporates the various timers and sensors needed for automatic operation as well as the 7-day exercise timer. Timer and sensor settings are fixed and non-adjustable, except for the 7-day exercise timer's day and time selection.

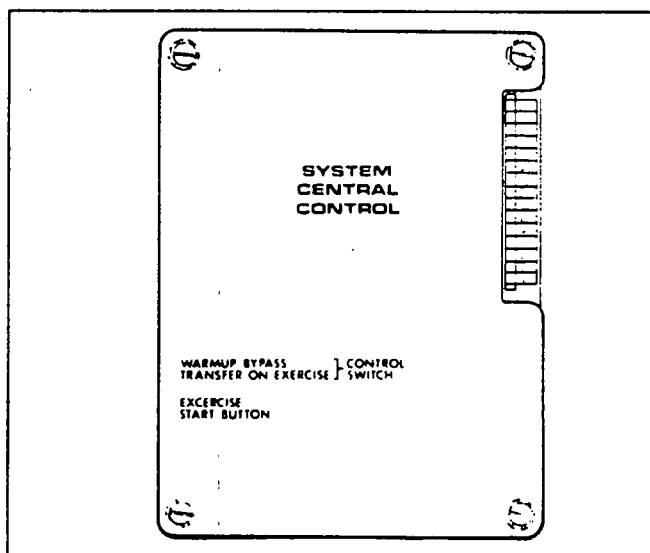

Figure 1. CPU Circuit Board Cover

Circuit Board Connector

A 15-pin connector is provided, to interconnect the CPU circuit board with other transfer switch components and circuits. The connector is shown in Figure 2. Pin numbers, associated wire numbers and circuit functions are listed in the chart that follows:

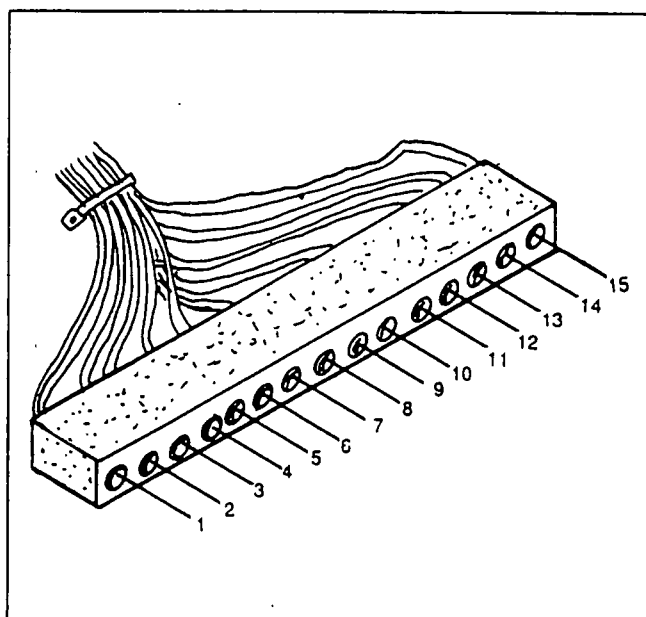

Figure 2. CPU Board Connector

Circuit Board Sensors and Timers

As previously mentioned, CPU board sensors and timers are fixed and non-adjustable. These include the following:

- An ENGINE MINIMUM RUN TIMER, fixed at 10 minutes.
- An ENGINE WARMUP TIMER, fixed at 30 seconds.
- A STANDBY VOLTAGE SENSOR, fixed at 80 percent of rated voltage.
- A STANDBY FREQUENCY SENSOR, fixed at 80 percent of rated frequency.
- A RETURN TO UTILITY TIMER, fixed at 30 seconds.
- An ENGINE COOLDOWN TIMER, fixed at 10 minutes.

The CPU board also provides (a) an engine warmup timer bypass switch, (b) a "set exercise time" switch, and (c) a "transfer on exercise" selector switch. See Section 10.5.

PIN NO.	WIRE NO.	CIRCUIT FUNCTION & DESCRIPTION
1	194	Delivers 12 volts DC to transfer relay coil with engine running.
2	202	Common ground
3	201	High (+) side of "Fast Test" signal circuit.
4	203	High (+) side of "Normal Test" signal circuit.
5	199	High (+) side of "utility voltage loss" sensor circuit.
6	177	Part of the 2-wire start circuit.
7	178	Part of 2-wire start circuit.
8	—	Not Used.
9	—	Not Used.
10	193	Low (grounded) side of time delay neutral relay coil circuit.
11	23	Low (grounded) side of transfer relay coil circuit.
12	191	Circuit board power supply from transformer TR1 (step-down "Standby" source voltage [about 21-24 volts AC] is delivered to this terminal and terminal 13).
13	192	Same as Pin No. 12.
14	185	Power supply for 7-day exercise timer. Reduced load terminal voltage from transformer TR2 is delivered here.
15	0	Same as Pin No. 14.

Section 10.5
SENSOR AND TIMER SETTINGS

Utility Voltage Sensor Circuit Board

VOLTAGE PICKUP SENSOR:

The voltage pickup sensor establishes the "Utility" power source voltage level at which retransfer back to that power source can occur. Easily adjustable to any setting between 70-95 percent of the nominal "Utility" power source voltage. The sensor was factory set to about 90 percent of "Utility" voltage.

VOLTAGE DROPOUT SENSOR:

Sensor establishes the "Utility" power source voltage level at which generator startup and transfer to "Standby" will be initiated. Sensor can be adjusted between 70-95 percent of the voltage pickup setting, is factory set to about 80 percent of that value.

LINE INTERRUPT DELAY TIMER:

This timer establishes a time delay interval between "Utility" voltage dropout below the voltage dropout sensor setting and generator startup. Such a time interval is required to prevent false starts that might otherwise occur because of transient voltage dips. Timer is adjustable from 0.1 to 10 seconds; it is factory set to about five (5) seconds.

NOTE: Wide differences can exist between "Utility" source supply voltages. It may be necessary to "calibrate" the utility voltage sensor circuit board to match "Utility" supply voltage. See "Circuit Board Calibration" on Page 10.3-2.

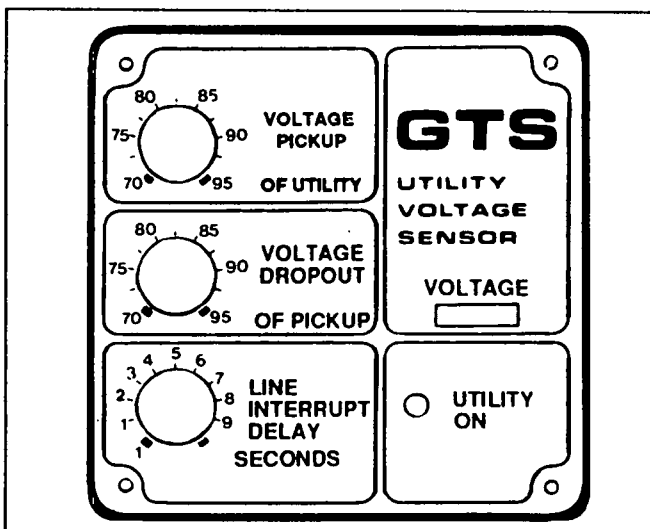

Figure 1. Utility Voltage Sensor Board Cover

CPU Circuit Board Selections

Sensors and timers on the CPU board are fixed and non-adjustable. However, several miniature switches are provided as follows.

ENGINE WARMUP TIMER BYPASS SWITCH:

Following engine startup, transfer of loads to the "Standby" source cannot occur until (a) the engine warmup timer has timed for about 30 seconds, (b) generator voltage has reached 80 percent of rated voltage, and (c) generator frequency has reached 80 percent of rated frequency.

If desired, the engine warmup timer can be bypassed. Transfer to "Standby" will then occur as soon as "Standby" voltage and frequency have reached 80 percent of rated voltage.

To bypass the engine warmup timer, actuate Switch "1" away from its "Off" position and toward the number "1". To place the engine warmup timer back into operation, actuate Switch 1 to its "Off" position.

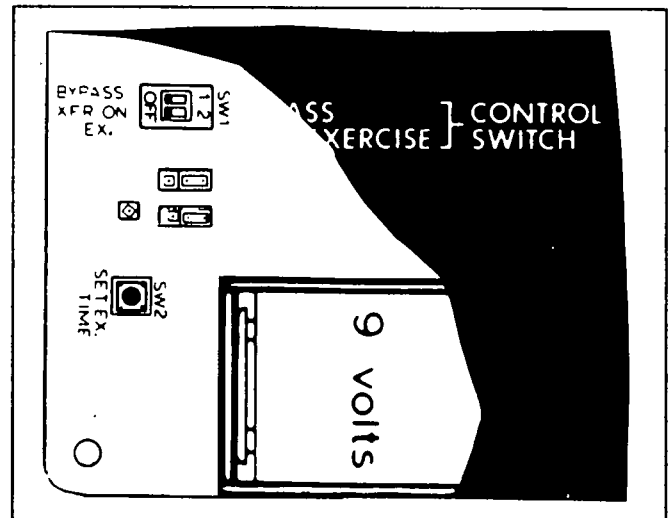

Figure 2. CPU Circuit Board Switches

TRANSFER ON EXERCISE SWITCH:

To transfer loads to the "Standby" power source during the 7-day exercise runup, actuate Switch 2 away from its "Off" position and toward the number "2". If no transfer is desired during exercise, set Switch 2 to "Off".

CPU Circuit Board Selections (Continued)
SELECTING EXERCISE DAY AND TIME OF DAY:

On the day and at the time of day you wish the system to start and exercise, push the "SET EX. TIME" switch in and hold for about 15 seconds. The generator will start and exercise every seven (7) days thereafter at the selected time of day.