

GENERAC®

“D” OPTION CONTROL PANEL

User Manual Operating Instructions

GENERAC
“D” OPTION
GENERAC®
CORPORATION

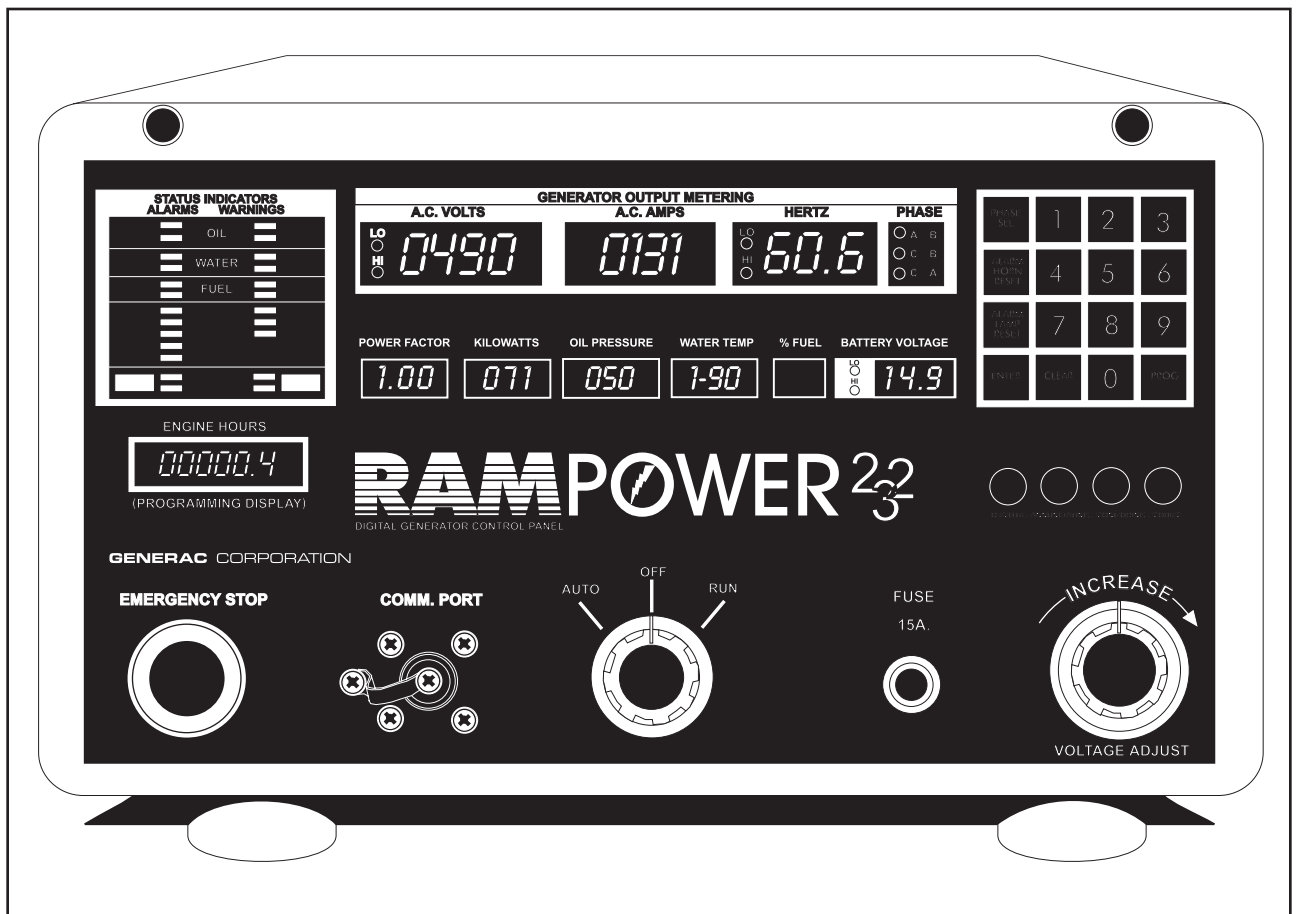

Manual No. A3303

Revision 0 (2/4/98)



THIS SYMBOL POINTS OUT IMPORTANT SAFETY INSTRUCTIONS, WHICH, IF NOT FOLLOWED, COULD ENDANGER THE PERSONAL SAFETY AND/OR PROPERTY OF YOURSELF AND OTHERS. READ AND FOLLOW ALL INSTRUCTIONS IN THE MANUAL BEFORE ATTEMPTING TO OPERATE THIS UNIT.

Printed in U.S.A.



OVERVIEW

The "D" option panel (or Rampower 232 tm) is a micro-processor based generating set control panel designed for Generac's range of Standby Generators. It has a fully digital user interface and comprehensive communications facilities.

The panel is housed in a sheet steel enclosure which meets NEMA 1 specifications. The front panel consists of a number of light emitting diode (LED) display windows showing generator operating conditions, a tactile keypad, alarm and status LED indicators, main fuse, emergency-stop switch and generator set controls.

CONTROL PANEL CIRCUIT BOARDS

The control panel contains three main circuit boards, the Automatic Voltage Regulator (AVR), various discrete components, and terminal blocks for external connections.

To find the location of the circuit boards, refer to the exploded view of the control panel in the back pages. The three main circuit boards have defined functions as follows.

■ PCB 1 MAIN CPU (CENTRAL PROCESSOR UNIT) BOARD

(P/N - A1053) This board houses the microprocessor, its memory, input and output (I/O) stages and all communication hardware (including optional modem for telephone system communications).

■ PCB 2 DISPLAY BOARD

(P/N - A1056) This board houses all the LED displays and annunciators and their respective driver circuitry.

■ PCB 3 INTERFACE BOARD

(P/N - A1054) This board houses all the components necessary to interface the CPU board to the "hostile" generator environment. This board conditions high voltage and current signals from the generator output. All control relays are mounted on this board. Connection to this board are by rugged screw terminals.

■ LOCATIONS OF CIRCUIT BOARDS

PCB's 1 and 2 are mounted together on the back of the hinged front panel, and PCB 3 is mounted on the left wall of the panel as you look at it from the front. The right wall houses the AVR and the optional electronic governor controller. Both of these units mounted on a chassis are accessible from the right side of the panel via removable covers to allow easy adjustment.

The rear wall houses the 2-amp or optional 10-amp battery charger subassembly.



WARNING: Remove 15 amp fuse from front panel during all engine maintenance to guard against accidental or remote startup.

DISPLAYS (Figure 1)

1. AC VOLTAGE DISPLAY (AC VOLTS)

A four digit LED display for monitoring the voltage of the selected phase. A key (PHASE SEL) selects which phase is displayed. LEDs indicate which phase is currently displayed. The range is 0-1,023VAC.

Figure 1 — Digital Displays on Option "D" Control Panel

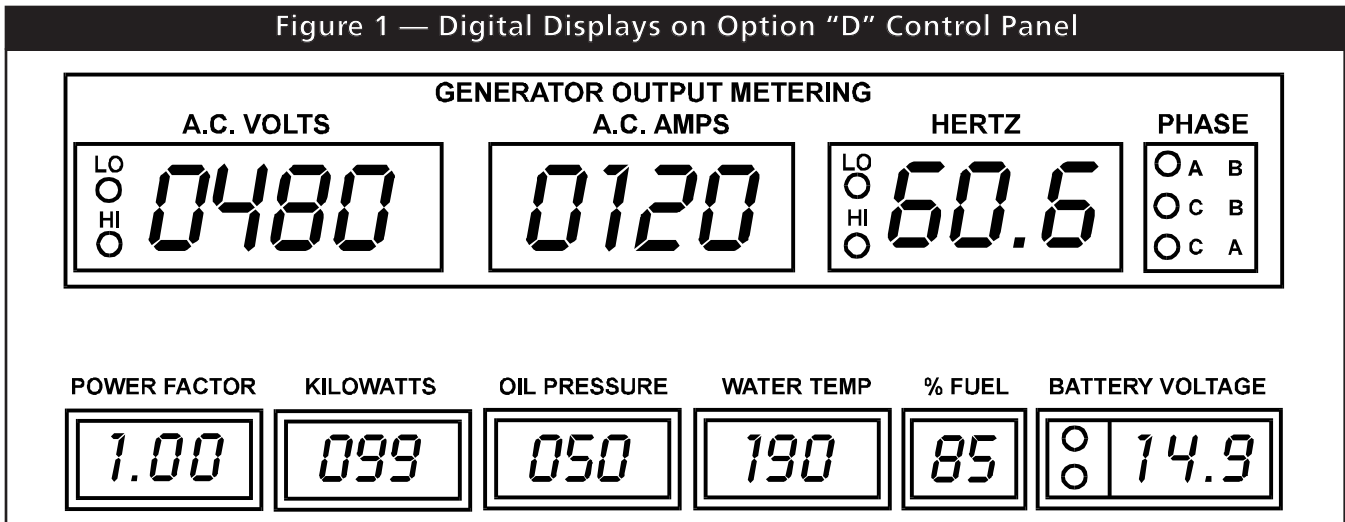



2. AC VOLTAGE INDICATORS (LO, HI)

A pair of LEDs (included in AC Volts Display), used to indicate that the generator's AC output voltage is high or Low. The set-points are user programmable. These alarms are latched and cause the alarm relay to latch.

Either will shut down the generator and cause a modem call-out if enabled. This alarm is enabled after the programmable alarm hold off timer expires.

3. AC CURRENT DISPLAY (AC AMPS)

A four digit LED display for monitoring the current in the selected phase. The range is 0-1,400A, depending on current transformer choice and setting of the programmable full scale current range.

4. FREQUENCY DISPLAY (HERTZ)

A three digit LED display for monitoring the frequency of the generator output. The range of this display is 40 to 70 Hz.

5. POWER FACTOR

A three digit LED display for monitoring the power factor of the selected phase. The range is 0-1.00.

6. POWER OUTPUT (KILOWATTS)

A three digit LED display for monitoring the total power output of the generator. The power output is the sum of all three phases, taking power factor into account.

7. OIL PRESSURE

A three digit display used to monitor engine oil pressure. The range is 0-100 PSI or 0-7.03 Kg/cm. If the sensor is short circuited, -S- will display. If the sensor is open circuited, -0- will display.

8. WATER TEMPERATURE

A three digit display used to monitor the engine water temperature. The range is 0° to 300° or -18° to 149°C. If the sensor is short circuited, -S- will display. If the sensor is open circuited, -0- will display.

% FUEL

An optional two digit display for monitoring the quantity of fuel remaining. The range is 0-99%.

10. BATTERY VOLTAGE DISPLAY

A three digit LED display for monitoring battery voltage. The range is 0 - 51.1VDC.

11. BATTERY VOLTAGE INDICATORS

A pair of LEDs (included in Battery Voltage Display) used to indicate a high or low battery voltage condition. The set points are user programmable. These alarms are latched and cause the alarm relay to latch. The do not shut down the generator but do cause a modem callout if enabled. The low battery indicator will be activated after six minutes of a low battery condition. This allows it to be used as a battery charger monitor.

12. ENGINE HOURS

A six digit LED display used to display engine running time in hours. The display is also used when entering the access code and changing settable parameters.

ALARM AND WARNING INDICATORS

(see Figure 2 on Page 4)

OIL

1. LOW OIL PRESSURE ALARM INDICATOR (LO PRES)

A red LED used to indicate a low oil pressure condition. The set point is user programmable. The alarm is latched and causes the alarm relay to latch, it shuts down the generator and causes a modem callout if enabled. This alarm is enabled after the programmable alarm hold off timer expires.

2. HIGH OIL TEMPERATURE ALARM INDICATOR (HIGH TEMP)

A red LED used to indicate a high oil temperature switch has been closed. This alarm is latched and causes the alarm relay to latch, it shuts down the generator and causes the modem to callout if enabled. This alarm is enabled at all times.

3. PRE-LOW OIL PRESSURE WARNING INDICATOR (PRE LO PRES)

A yellow LED used to indicate a warning low oil pressure condition exists. The set point is user programmable.

4. PRE-HIGH OIL TEMPERATURE (PRE HI TEMP)

A yellow LED used to indicate a high oil temperature switch has been closed.

WATER

5. HIGH WATER TEMPERATURE ALARM INDICATOR (HI TEMP)

A red LED used to indicate a high water temperature condition. The set point is user programmable. The alarm is latched and causes the alarm relay to latch. The alarm shuts down the generator and causes a modem callout if enabled. The alarm is enabled after the programmable alarm hold off timer expires.

7. PRE-HIGH WATER TEMPERATURE WARNING INDICATOR (PRE HI TEMP)

A yellow LED used to indicate a warning high water temperature condition exists. The set point is user programmable.

8. LOW WATER TEMPERATURE WARNING INDICATOR (LO TEMP.)

A yellow LED used to indicate a warning low water temperature exists. The set point is user programmable.

FUEL

9. HIGH FUEL ALARM INDICATOR (HI)

A red LED used to indicate a high fuel switch has been closed. This alarm is not latched and does not cause the alarm relay to latch, it does not shut down the generator and does not cause a modem callout. This alarm is enabled at all times. You also have the option of setting a level on the "FUEL %" display to activate this indicator.

10. CRITICAL LOW FUEL ALARM INDICATOR (CRITICAL LO)

A red LED used to indicate a low fuel switch has been closed. May also be optioned to activate on a settable number on the fuel % display. This alarm is latched and causes the alarm relay to latch, it does not shut down the generator and causes a modem callout if enabled. This alarm is enabled at all times.

11. LOW FUEL WARNING INDICATOR (LO)

A yellow LED used to indicate a low fuel switch has been closed. May also be optioned to activate below a settable number on the fuel % display.

12. EMERGENCY STOP ALARM INDICATOR (EMG STOP)

A red LED used to indicate the emergency stop switch has been activated. This alarm is latched and causes the alarm relay to latch, it shuts down the generator and causes a modem callout if enabled. This alarm is enabled at all times.

Figure 2 — Alarm Indicators

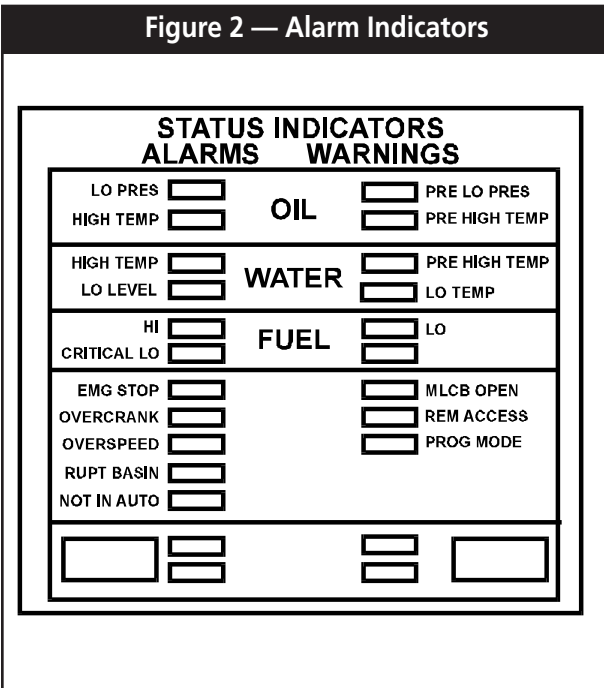

6. LOW LEVEL WATER ALARM INDICATOR (LO LEVEL)

A red LED used to indicate the radiator water level is low. The alarm is latched and causes the alarm relay to latch. The alarm shuts down the generator and causes a modem callout if enabled. This alarm is enabled after the programmable alarm hold off timer expires.

13. OVERCRANK ALARM INDICATOR (OVERCRANK)

A red LED used to indicate the engine did not start after eight starting attempts. The starting cycle is a programmable number of seconds of cranking followed by five seconds of OFF time. This alarm is latched, causes the alarm relay to latch, shuts down the generator and causes a modem callout if enabled.

14. GENERAL OVERSPEED ALARM INDICATOR (OVERSPEED)

A red LED used to indicate an overspeed condition. The set point is user programmable. The alarm is latched and causes the alarm relay to latch. The alarm shuts down the generator and causes a modem callout if enabled. The alarm is enabled after the engine starts. This indicator also illuminates if the RPM sensor fails.

15. RUPTURED BASIN ALARM INDICATOR (RUPT. BASIN)

A red LED used to indicate the double wall fuel tank has been ruptured. A float switch in the outer tank closes when a rupture occurs. The alarm latches, causes the alarm relay to latch, does not shut down the generator and causes the modem to callout if enabled. This alarm is enabled at all times.

16. NOT IN AUTO ALARM INDICATOR (NOT IN AUTO)

A red LED used to indicate the panel switch is not set to auto-start mode.

17. MAIN LINE CIRCUIT BREAKER (MLCB OPEN)

A yellow LED used to indicate a main line circuit breaker is open. This is an optional switch input.

18. REMOTE ACCESS INDICATOR (REM ACCESS)

A yellow LED used to indicate that modem communication is currently active.

19. PROGRAM MODE WARNING INDICATOR

A yellow LED used to indicate that the panel is in the program mode.

SPARES

20.SPARE ALARM INDICATORS (SPARES)

Two spare red LEDs for future alarms. These alarms are latched and cause the alarm relay to latch, they do shut down the generator and cause a modem callout if enabled. These alarms are enabled after the hold off timer expires.

21.SPARE WARNING INDICATORS (SPARES)

Two spare yellow LEDs for future warning indicators.

KEYPAD

Figure 3 — Keypad Features

| | | | |
|------------------|-------|---|------|
| PHASE SEL | 1 | 2 | 3 |
| ALARM HORN RESET | 4 | 5 | 6 |
| ALARM LAMP RESET | 7 | 8 | 9 |
| ENTER | CLEAR | 0 | PROG |

1. NUMERIC KEYS 0-9

Decimal numbers are included on a keypad for entry of passwords and setting of default values.

2. ENTER AND CLEAR KEYS

The enter key will be used to accept data input from the numeric keys. The clear key will be used to remove erroneous entries during programming.

3. PROGRAM KEY (PROG)

This button is used to enter the local programming mode. After pressing this key the programming display will show the word - 'access' prompting the user for the password. The password is a six digit number that is entered on the numeric keys and is displayed on the hour meter/programming display.



4. ALARM HORN RESET

This button is used to reset the alarm relay contacts.

5. ALARM LAMP RESET

This button is used to reset alarms that have been latched.

6. PHASE SELECT

This button will be used to select which of three phases is to be displayed.

CONTROLS (Figure 4)

1. EMERGENCY STOP SWITCH

One of two types will be fitted. This switch (colored RED) is a normally-closed, single-action, latching push button, which, when operated will immediately cause the generator to shut down.

2. RS-232 LOCAL COMMUNICATION PORT (COMM PORT)

This connector allows connection of a local computer to the panel for easy programming and diagnostic checking.

3. AUTO-OFF-RUN SWITCH

A 3-position rotary switch is provided for generator control. In 'Auto' the generator will wait for a signal, such as from an Automatic Transfer Switch. When it receives the remote start signal it will automatically initiate the generator start sequence. This only occurs assuming no shutdown alarm condition exists.

When selected to the 'Run' position, the generator will instantly be commanded to start assuming that no shutdown alarm condition exists. In the "Off" position the generator is inhibited from starting.

4. MAIN DC FUSE (FUSE 15A)

This fuse is rated at 15A, and is of the 1.25" x 0.25" glass type. Removal of this fuse inhibits all control panel functions, and is recommended during all maintenance operations.

5. VOLTAGE TRIM POTENTIOMETER (VOLTAGE ADJUST)

This control allows adjustment of the generator output voltage in the range +/- 5%.

INPUTS

■ AC VOLTAGE

Four terminals (PCB3: J2-1, J2-2, J2-3, J2-4) are provided for voltage measurement. Maximum input voltage is 1000VAC.

NOTE: Correct phasing for these terminals is essential for correct operation (see phasing diagrams on pages 13, 14 and 15).

■ AC CURRENT

Four terminals (PCB3: J2-7, J2-9, J2-11, J2-10) are provided for current measurement. The inputs will interface with current transformers having a 5A secondary winding at their rated current.

NOTE: Correct phasing for these terminals is essential for correct operation (see phasing diagram pages 13, 14 and 15).

Figure 4 — Control Switches and Knobs on Option "D" Control Panel

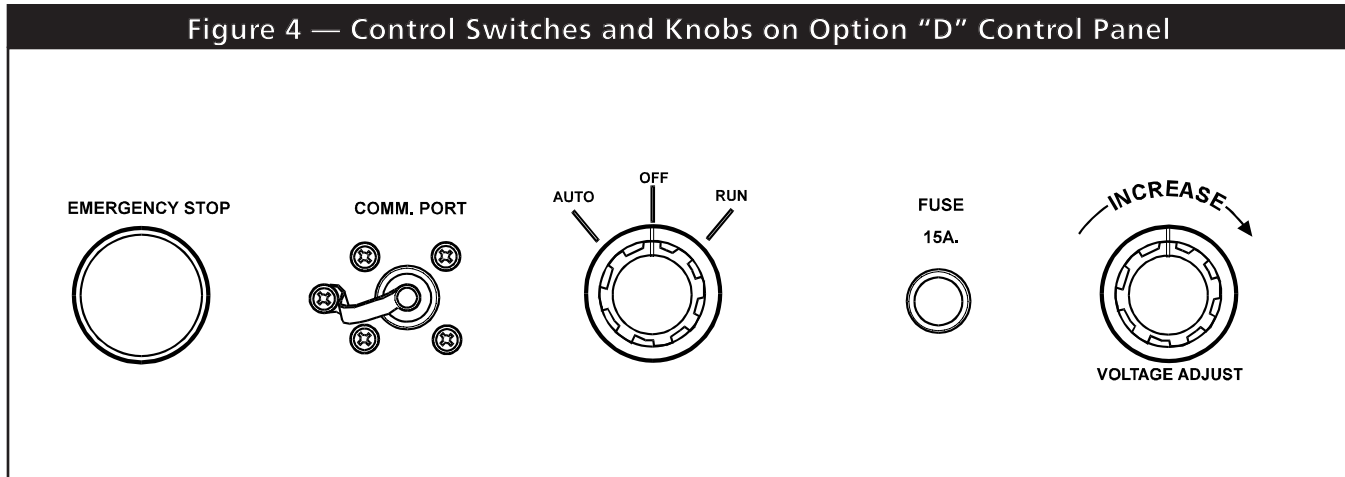



■ FUEL LEVEL INPUT (PCB1: J10-1)

An optional analogue input is provided for fuel level measurement. This is a 0-5V input. An input signal of 0V is equivalent to 0% remaining fuel and 5V is equivalent to 99% remaining fuel. The relationship between input voltage and fuel level is linear.

■ OIL PRESSURE INPUT (PCB1: J10-2)

An analogue input is provided for oil pressure measurement. This input will interface to the standard Generac sender unit (P/N - 53666).

■ WATER TEMPERATURE INPUT (PCB1: J10-3)

An analogue input is provided for coolant temperature measurement. This input will interface to the standard Generac thermistor sensor (P/N - 53667).

■ ENGINE SPEED SENSOR INPUT (PCB1: J10-5)

An input is provided for sensing engine speed by counting teeth on the flywheel via a magnetic proximity probe. The input interfaces to the Generac standard magnetic pickup (P/N - 81714).

■ COOLANT LEVEL SENSOR INPUT (PCB1: J10-4)

A dedicated analogue input is provided for sensing low coolant level. The input will interface to the Generac coolant level sensor (P/N - 57522).

■ EMERGENCY STOP CONTACT INPUT (PCB3: TB2-1, TB2-3)

An input is provided for an emergency stop switch(es). The switch contact is normally closed.

■ TRANSFER SWITCH/REMOTE START INPUT (PCB1: J7-12)

When selected to "AUTO" and this input is grounded, the generator will commence its start sequence. When the utility voltage drops, the transfer switch/remote start system will close a contact to ground this input.

■ PRE-HIGH OIL TEMPERATURE INPUT (PCB1: J7-7)

An optional input is provided for a pre-warning high oil temperature switch. (Switch to ground to alarm)

■ HIGH OIL TEMPERATURE INPUT (PCB1: J7-6)

An optional input is provided for an alarm high oil temperature switch. (Switch to ground to alarm)

■ HIGH FUEL LEVEL INPUT (PCB1: J7-5)

An input is provided for a high fuel level switch. (Switch to ground to alarm)

■ CRITICAL LOW FUEL LEVEL INPUT (PCB1: J7-4)

An input is provided for a low fuel level switch. (Switch to ground to alarm)

■ MAIN LINE CIRCUIT BREAKER INPUT (PCB1: J7-2)

An input is provided for a circuit breaker auxiliary contact to indicate that the main line circuit breaker is open. (Switch to ground to alarm)

■ RUPTURED BASIN INPUT (PCB1: J7-3)

An input is provided for a level switch indicating the fuel tank is ruptured. (Double wall fuel tanks only.) (Switch to ground to alarm)

■ SPARE ALARM INPUTS (PCB1: J7-1, J7-9)

Two inputs are provided for spare alarms. (Switch to ground to alarm)

■ SPARE WARNING INPUTS (PCB1: J7-10, J7-11)

Two inputs are provided for spare warning conditions. (Switch to ground to alarm)



OUTPUTS

■ STARTER SOLENOID OUTPUT (PCB3: TB1-8, TB1-9)

A relay contact output is provided to activate the starter solenoid. This form A relay is rated at 10 amps at 28VDC.

■ ALARM OUTPUT (PCB3: TB1-17(NC), TB1-18(COM), TB1-19(NO))

A relay contact output is provided that will activate on an alarm condition. This form C relay is rated at 10 amps at 28VDC.

■ LOAD CONTROL OUTPUT (PCB3: TB1-14(NC), TB1-15(COM), TB1- 16(NO))

A relay contact output is provided for load control. This contact will not energize unless the generator is running. It is a form C relay rated at 10 amps at 28VDC.

■ AUXILIARY OUTPUT (PCB3: TB1-11(NC), TB1-12(COM), TB1- 13(NO))

A relay contact output is provided for optional use. This form C relay is rated 10 amps at 28VDC.

■ PRE-HEATER OUTPUT (PCB3: TB1-9, TB1-10)

A relay contact output is provided to activate a diesel pre-heater. This form A relay is rated at 10 amps at 28VDC.

■ FUEL CONTROL RELAY (PCB3: TB1-5, TB1-6)

A relay contact output is provided to control the fuel solenoid/valve. This form A relay is rated at 10 amps at 28VDC.

COMMUNICATIONS

■ FRONT PANEL COMMUNICATIONS PORT

The front panel includes a connector for RS-232 serial communication.

■ MODEM

The unit can optionally be provided with a 2400 bps modem with "AT" command set which is FCC part 68 approved. The modem will allow performing the functions of the front panel at a remote site. However, the modem functions will not allow remote control of the engine if the front panel AUTO-OFF-RUN switch is in OFF or RUN mode.

■ REMOTE COMMUNICATIONS PORT

A RS485 communications port is provided on the main CPU board for remote annunciation. An optional remote annunciator will be available. The serial data available will include - the generator running status, battery charger failure, low battery voltage, high battery voltage, overcrank, overspeed, generator power, line power, not in auto, high water temperature, low oil pressure, pre-low fuel, pre-low water temp, pre-high water temp and pre-low oil pressure.

■ DIAL OUT OPTION

The dial out feature allows the panel to call out to a PC (computer) running GENLINK software when any alarm (red LEDs) occurs. Once this feature has been implemented the rampower software is placed in standby mode and waits for calls from any generator programmed for dial out. The program will then display the alarm responsible for dial out.

OPERATION OF GENERAC DIGITAL GENERATOR CONTROL PANEL

■ USING THE KEYBOARD

The use of most keys is self explanatory, but the operation of several keys requires some explanation. Pressing "ALARM RESET" turns off only the alarm relay. Alarm conditions continue to be displayed. Pressing "ALARM LAMP RESET" clears all alarm LEDs that are not current.

Pressing the "PROG" key will cause the programming digits to display "ACCESS". At this time, the access code must be entered (see Programmable Option 28). If an invalid access code is entered, the program will do nothing. Additional characters may be entered in an attempt to log on (only the last 6



digits are recognized). If no good code is entered, or no keyboard activity has occurred for 2 minutes, the program will revert to running time display.

If the correct access code is entered, the display will change to "00". At this time, the program is waiting for an option (see list below) to be entered. Twenty-eight options may be displayed and changed, if desired. The current setting remains unchanged if you press <ENTER>, or you can change it by entering a new number followed by <ENTER>. Exit the keyboard routine by pressing <ENTER> again any time the display shows "00".

Program variables can be modified in AUTO, OFF, and RUN

modes. It is recommended that the variables be changed while panel is in the OFF mode.

The options are listed in the chart below:

1. SELECT ENGLISH OR METRIC UNITS

Units will be changed on the panel for oil and pressure and water temperature.

2. FUEL DISPLAY

The fuel display should be turned off when an analogue fuel sensor is not being used. Alarm and warning leds for fuel are activated by either the critical low and high fuel switches or

| PROGRAMMABLE OPTIONS | | | |
|------------------------------------|-----------|------------------------------|--------------|
| DEFAULT | DEFAULT | RANGE or ALT | YOUR SETTING |
| 1. Select English or metric units. | 1=English | 2=Metric | |
| 2. Fuel display on/off | 1=OFF | 2=ON | |
| 3. Pre low oil pressure | <15 psi | 0-100 psi | |
| 4. Low oil pressure | <10 psi | 0-100 psi | |
| 5. Low water temp. | <90°F | 0-300°F | |
| 6. Pre high water temp. | >220°F | 0-300°F | |
| 7. High water temp. | >250°F | 0-300°F | |
| 8. Critical low fuel | <5% | 0-99% | |
| 9. Low fuel | <10% | 0-99% | |
| 10. High fuel | >95% | 0-99% | |
| 11. Low AC voltage | <90 VAC | 0-1023 VAC | |
| 12. High AC voltage | >230 VAC | 0-1023 VAC | |
| 13. Low battery voltage | <12.2 VDC | 0-51.1 VDC | |
| 14. High battery voltage | >15.0 VDC | 0-51.1 VDC | |
| 15. Low frequency limit | <57 Hz | 40-70 Hz | |
| 16. High frequency limit | >63 Hz | 40-70 Hz | |
| 17. Starting speed | >500 RPM | 0-3600 RPM | |
| 18. Overspeed | >2100 RPM | 0-3600 RPM | |
| 19. Alarm hold off time | 10 SEC | 0-60 SEC | |
| 20. Crank cycle on time | 5 SEC | 5-15 SEC | |
| 21. Flywheel teeth | 100 | 75-200 | |
| 22. Load control | 1=OFF | 2=ON | |
| 23. Set/reset aux output 1 | 1=OFF | 2=ON | |
| 24. Set CT Primary current | 150 | 50-1400A | |
| 25. Preheat time on | 0 SEC | 0-30 SEC | |
| 26. Preheat while cranking | 2=ON | 1=OFF | |
| 27. Select phasing | 1=SINGLE | 1=SINGLE 2=WYE 3=DELTA | |
| 28. Set user code | 000000 | 000000-999999 | |



the programmed values used with the analog sensor.

3. PRE LOW OIL PRESSURE

See alarm and warning indicators page 3.

4. LOW OIL PRESSURE

See alarm and warning indicators page 3.

5. LOW WATER TEMPERATURE

See alarm and warning indicators page 4.

6. PRE HIGH WATER TEMPERATURE

See alarm and warning indicators page 4.

7. HIGH WATER TEMPERATURE

See alarm and warning indicators page 4.

8. CRITICAL LOW FUEL

Used with analogue sensor to turn on red alarm led. See alarm and warning indicators page 4.

9. LOW FUEL

Used with analogue sensor to turn on yellow warning led. See alarm and warning indicators page 4.

10. HI FUEL

Used with analogue sensor to turn on red alarm led. See alarm and warning indicators page 4.

11. LOW AC VOLTAGE

A red led next to the AC VOLTS display is used to indicate this alarm. If the generator's AC voltage drops below this set value for more than 0.5 seconds an alarm occurs and the engine shuts down. The alarm is latched and causes the alarm relay to latch and produce a modem callout if enabled. This alarm is activated after the alarm hold off time is complete.

12. HIGH AC VOLTAGE

A red led next to the AC VOLTS display is used to indicate this alarm. If the generator's AC voltage goes above this set value for more than 0.5 seconds an alarm occurs and the engine is shutdown. The alarm is latched and causes the alarm relay to latch and produce a modem callout if enabled. This alarm is activated after the alarm hold off time is complete.

13. LOW BATTERY VOLTAGE

A red led next to the battery display is used to warn that battery voltage is below programmed limits. No shutdown occurs with this warning.

14. HIGH BATTERY VOLTAGE

A red led next to the battery display is used to warn that battery voltage is above programmed limits. No shutdown occurs with this warning.

15. LOW FREQUENCY LIMIT

A red led next to the HERTZ display is used to indicate this alarm. If the generator's frequency drops below this set value for more than 0.5 seconds an alarm occurs and the engine is shut down. The alarm is latched and causes the alarm relay to latch and produce a modem callout if enabled. This alarm is activated after the alarm hold off time is complete.

16. HIGH FREQUENCY LIMIT

A red led next to the HERTZ display is used to indicate this alarm. If the generator's frequency goes above this set value for more than 0.5 seconds an alarm occurs and the engine is shutdown. The alarm is latched and causes the alarm relay to latch and produce a modem callout if enabled. This alarm is activated after the alarm hold off time is complete.

17. STARTING SPEED

This is the speed at which the engine becomes self-sustaining and causes the starter to disengage. Alarm hold off timer is started when this rpm has been reached.

18. OVERSPEED

See alarm and warning indicators page 4.

19. ALARM HOLD OFF TIME

All alarms are ignored during alarm hold off time. If an alarm still persists after the hold off time it will become active.

20. CRANK CYCLE ON TIME

This is the length of time that starter stays engaged when given a command to start. There will be a 5 second off time after each on time. After 8 unsuccessful tries (each try consisting of 1 cycle crank on time and 1 off time) the overcrank alarm will latch the engine off and the alarm led will turn on.



21.FLYWHEEL TEETH

Preset at the factory. This is the number of teeth on the starter ring gear.

22.LOAD/UNLOAD CONTROL

This load control relay output has NO/NC contacts which can be used to connect the generator to the load once the generator's output voltage and frequency climb above the preprogrammed low AC voltage and low frequency limits. This relay can be controlled from the front panel or through GENLINK software via modem or RS232. See outputs on page 8.

23.ON/OFF AUX 1

This auxiliary relay output has NO/NC contacts which can be used as general purpose relay under front panel control. This relay can also be controlled from the front panel or through GENLINK software via modem or RS232. See outputs on page 8.

24.SET CT PRIMARY CURRENT

This is the current rating for the primary side of the CT with secondary side being 5 amps. D-panels are set up to use 5 amp secondaries.

25.PREHEAT TIME ON

Length of time that pre-heat device on diesel engine energized.

26.PREHEAT WHILE CRANKING

Allows pre-heater to be energized while engine is cranking.

27.SET USER CODE

This allows the user to change the default password. If new user password is lost or misplaced it is possible for Generac to access the panel through remote software to determine the password. It would be necessary that remote communication

be established with the panel via modem for Generac to access the password. All panels ship with the password defaulted to zero (000000).

28.SELECT PHASING

There are 3 possible generator configurations. They are single phase, 3 phase wye, or 3 phase Delta.

INSTALLATION NOTES

The "D" option control panel is designed to enhance the current range of Generac control panels. As such you can easily retrofit the panel to most Generac Standby Generators.

The anti-vibration mountings, fixing centers and overall dimensions are compatible with existing panels, as are the lower panel connections and most of the engine electrical connections. All engine temperature and oil pressure alarms and pre-alarms are derived from the analogue signals from engine senders, so the existing alarm and shutdown switches become redundant, these should be disconnected or removed from the engine.

Lower panel connections are identical and the panel plugs in to the existing lower panel connector. The only additional lower panel wiring is a separate neutral wire which should be wired from the lower panel neutral bar to the bullet connector marked "00" which is part of the lower panel connection harness protruding from the bottom of the 'D' option panel.

Refer to the wiring diagram, electrical schematic and typical engine schematic for more installation information.

PHASING DIAGRAMS

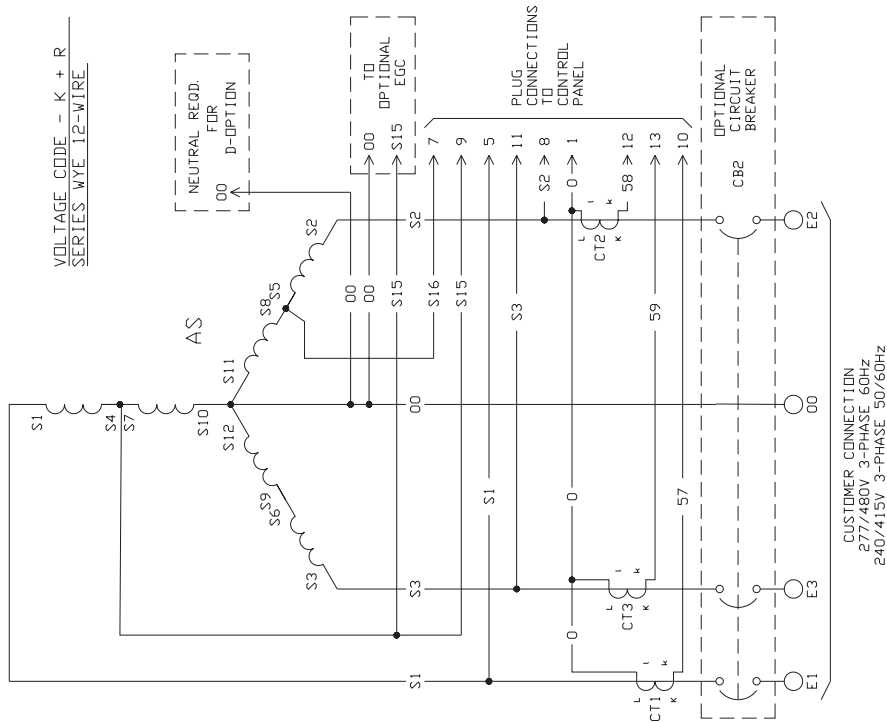
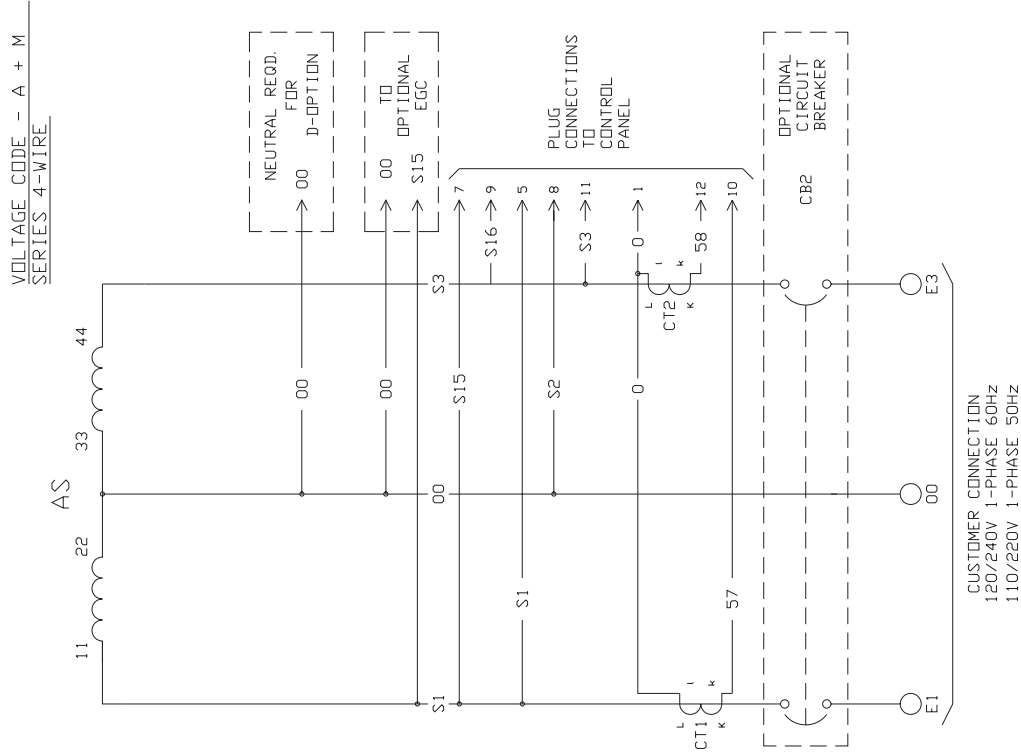

PHASING DIAGRAMS

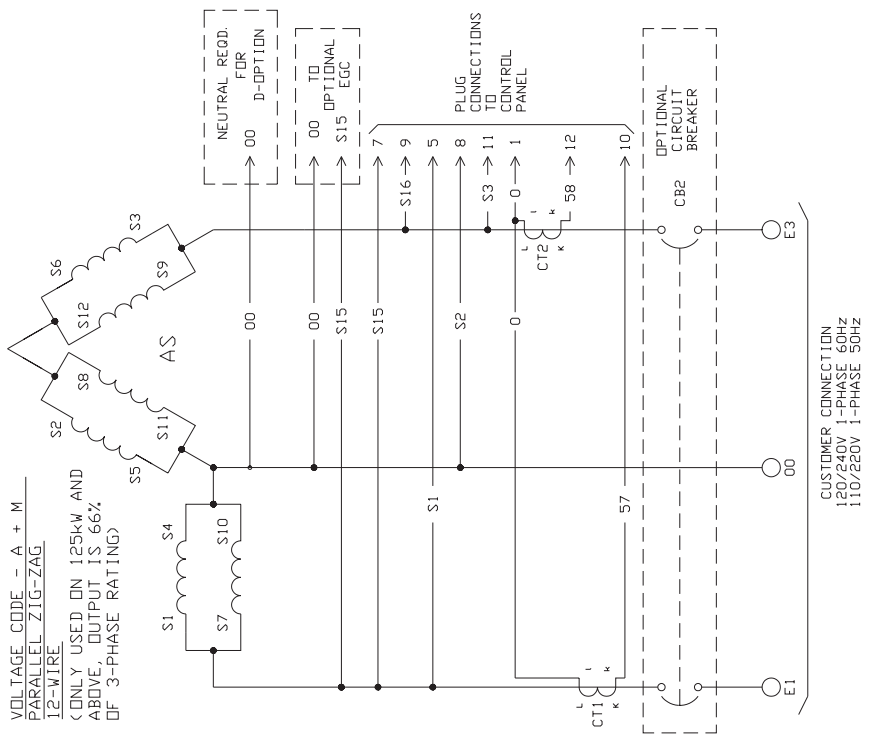
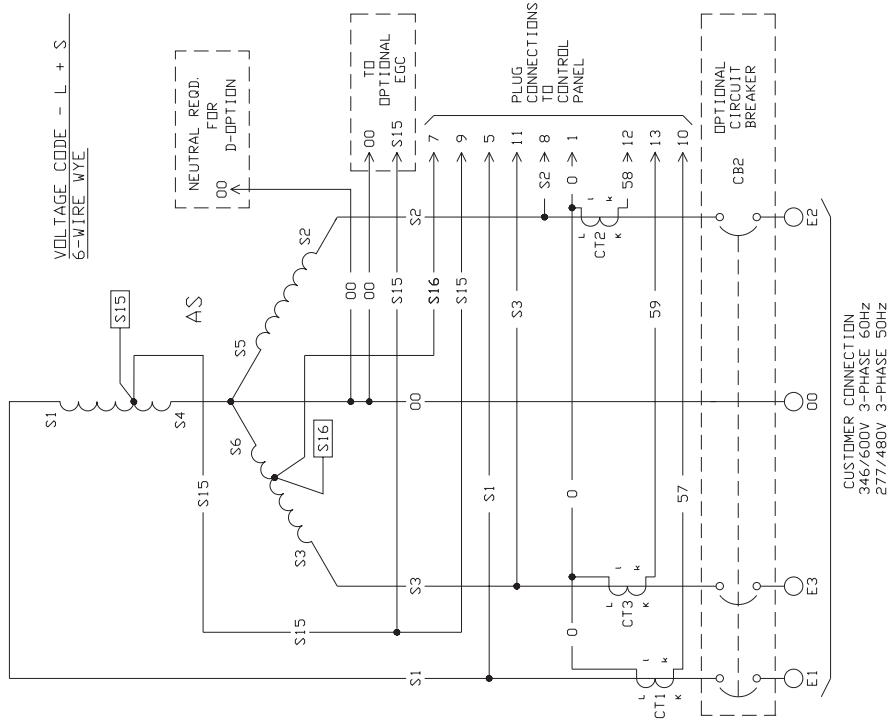

PHASING DIAGRAMS

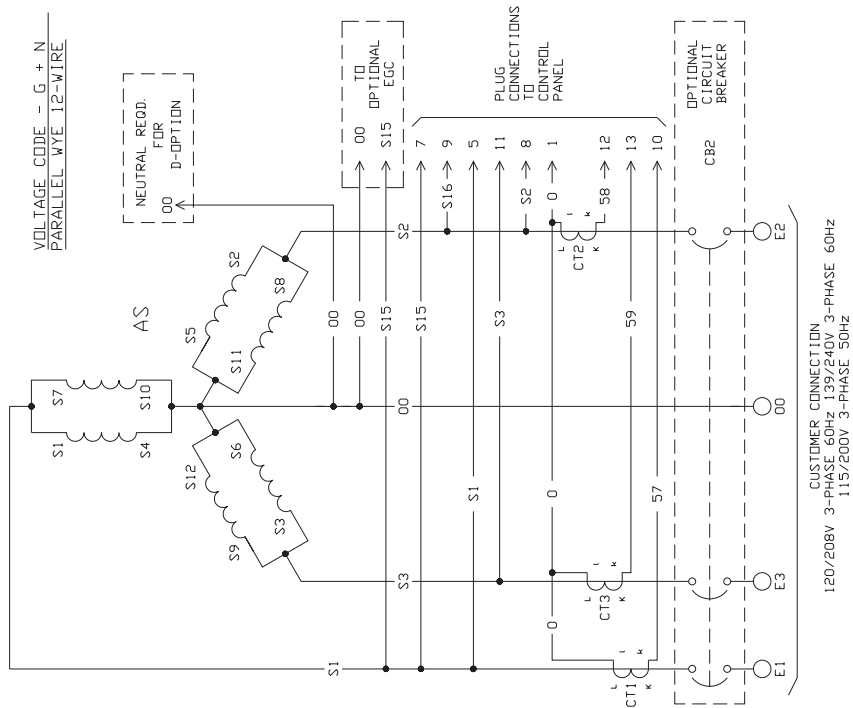
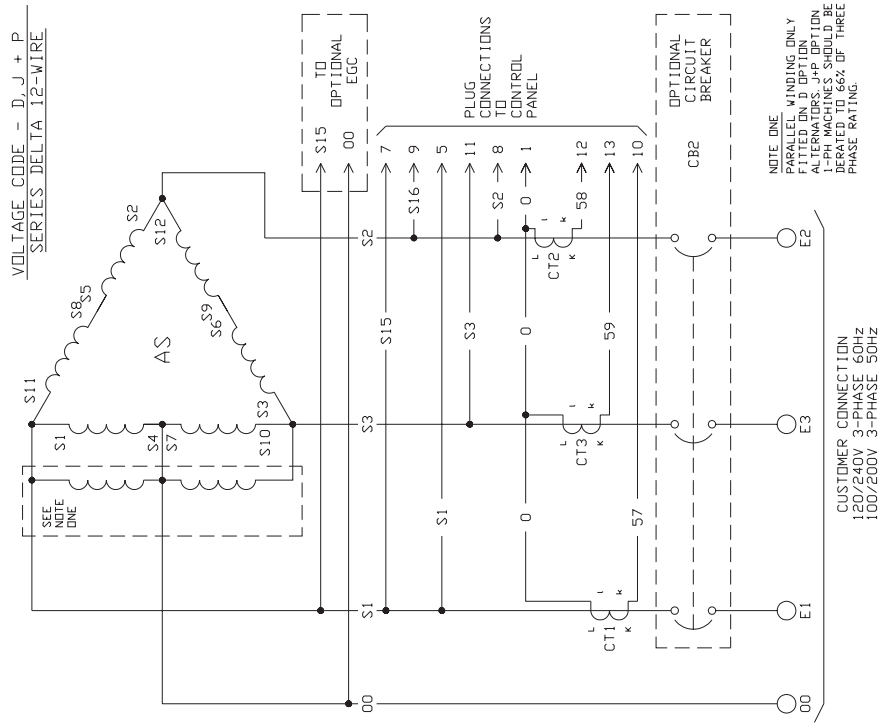

PHASING DIAGRAMS

EXCITATION POWER OPTIONS (USE EITHER OPTION A OR OPTION B ONLY)

OPTION A - DISPLACED PHASE WINDING

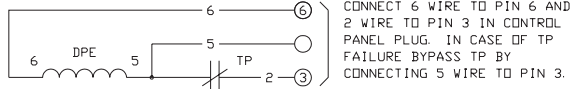

OPTION B - PERMANENT MAGNET GENERATOR (WITH AUXILIARY BATTERY CHARGE WINDINGS)

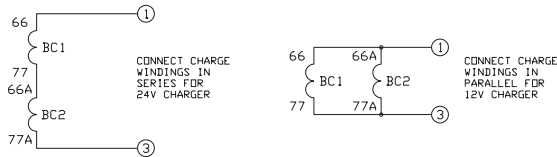
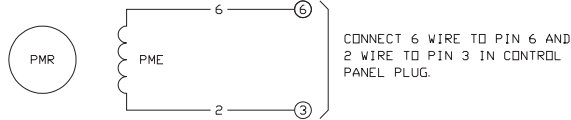

EXCITER FIELD OPTIONS

OPTION A - UNITS WITH BRUSHES

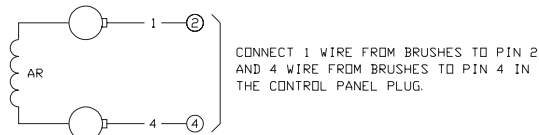

OPTION B - BRUSHLESS UNITS

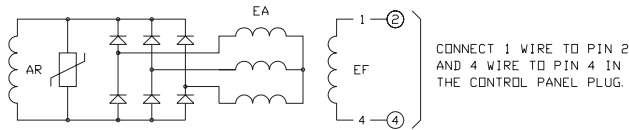

OPTIONAL CIRCUIT BREAKER STATUS AUXILIARY CONTACT

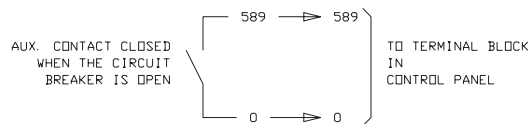

LEGEND

- AR ALTERNATOR ROTOR
- AS ALTERNATOR STATOR
- BC BATTERY CHARGE WINDING
- CB2 MAIN CIRCUIT BREAKER (OPTIONAL)
- CT CURRENT TRANSFORMER
- DPE DISPLACED PHASE EXCITATION WINDING
- EA BRUSHLESS EXCITER ARMATURE
- EF BRUSHLESS EXCITER FIELD
- EGC ELECTRONIC GOVERNOR CONTROL
- PMR PERMANENT MAGNET ROTOR
- PME PERMANENT MAGNET EXCITATION WINDING
- TP THERMAL PROTECTOR (AUTO-RESET)

READ THIS DRAWING IN CONJUNCTION WITH WIRING DIAGRAMS Nos. 99336 + 99491

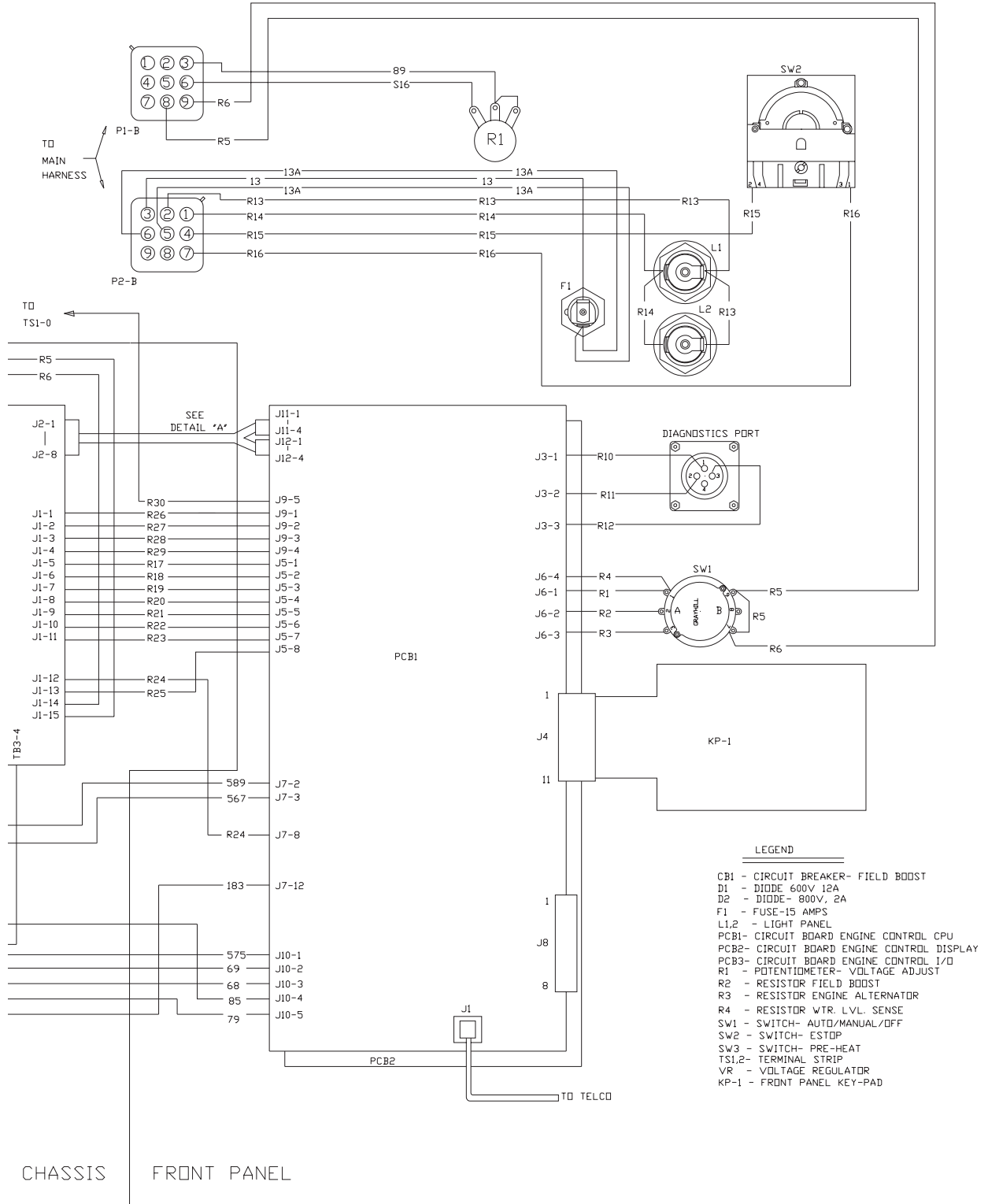

- LEGEND**
- CB1 - CIRCUIT BREAKER- FIELD BOOST
 - D1 - DIODE 600V 12A
 - D2 - DIODE- 800V, 2A
 - F1 - FUSE-15 AMPS
 - L1,2 - LIGHT PANEL
 - PCB1- CIRCUIT BOARD ENGINE CONTROL CPU
 - PCB2- CIRCUIT BOARD ENGINE CONTROL DISPLAY
 - PCB3- CIRCUIT BOARD ENGINE CONTROL I/O
 - R1 - POTENTIOMETER- VOLTAGE ADJUST
 - R2 - RESISTOR FIELD BOOST
 - R3 - RESISTOR ENGINE ALTERNATOR
 - R4 - RESISTOR WTR. LVL. SENSE
 - SW1 - SWITCH- AUTO/MANUAL/OFF
 - SW2 - SWITCH- ESTOP
 - SW3 - SWITCH- PRE-HEAT
 - TS1,2 - TERMINAL STRIP
 - VR - VOLTAGE REGULATOR
 - KP-1 - FRONT PANEL KEY-PAD

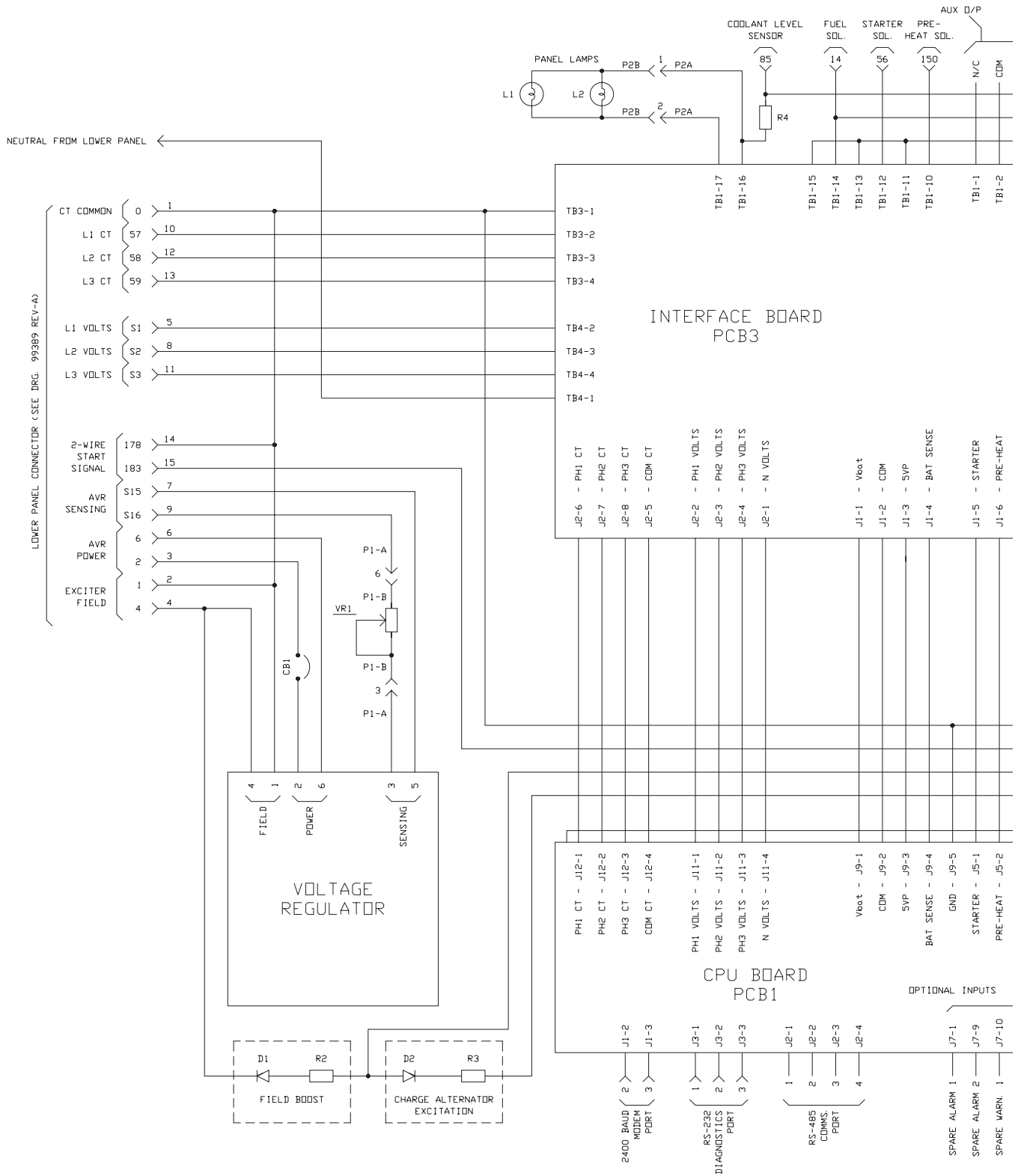

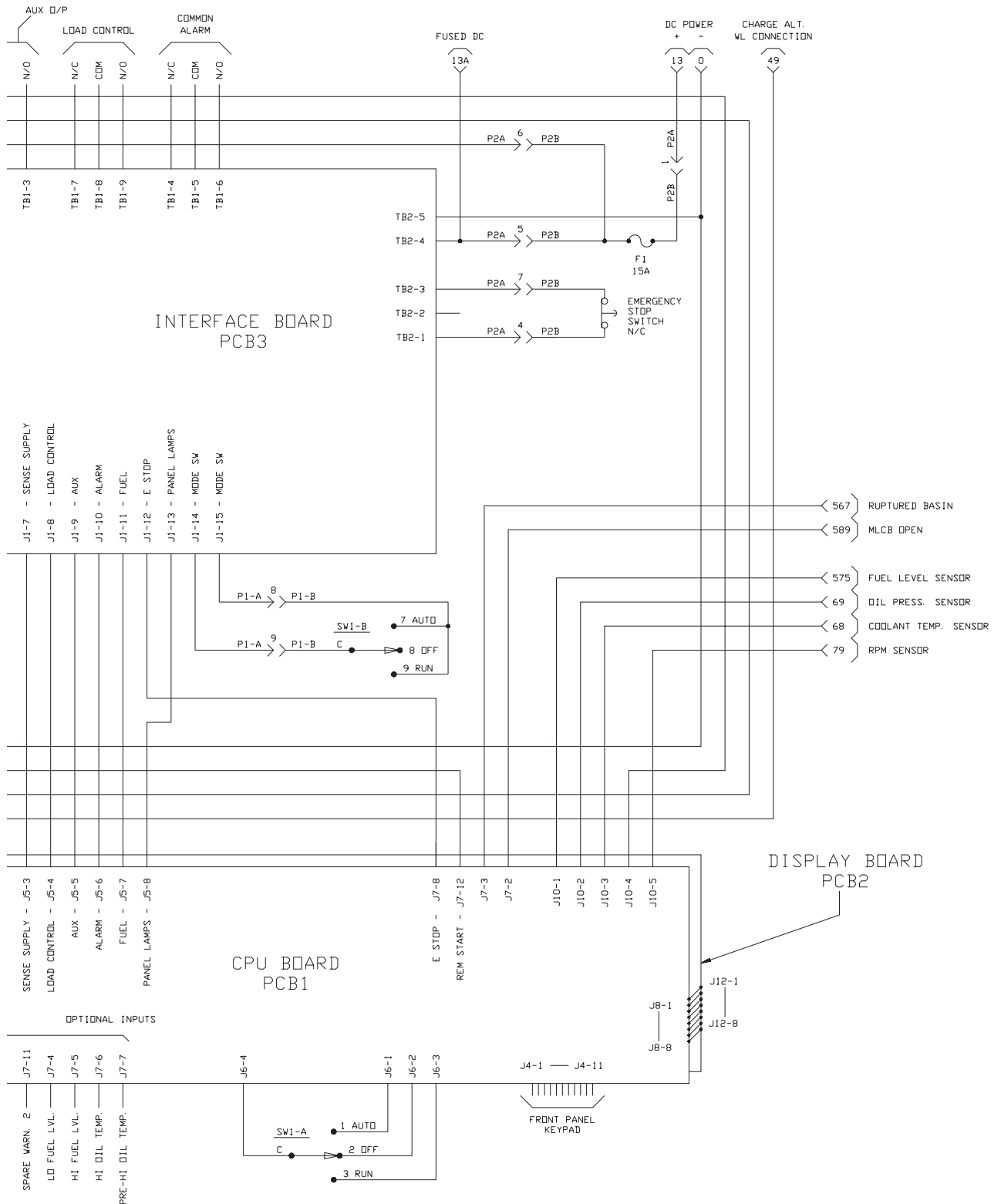

EXPLODED VIEW — CONTROL PANEL

Drawing No. A3103

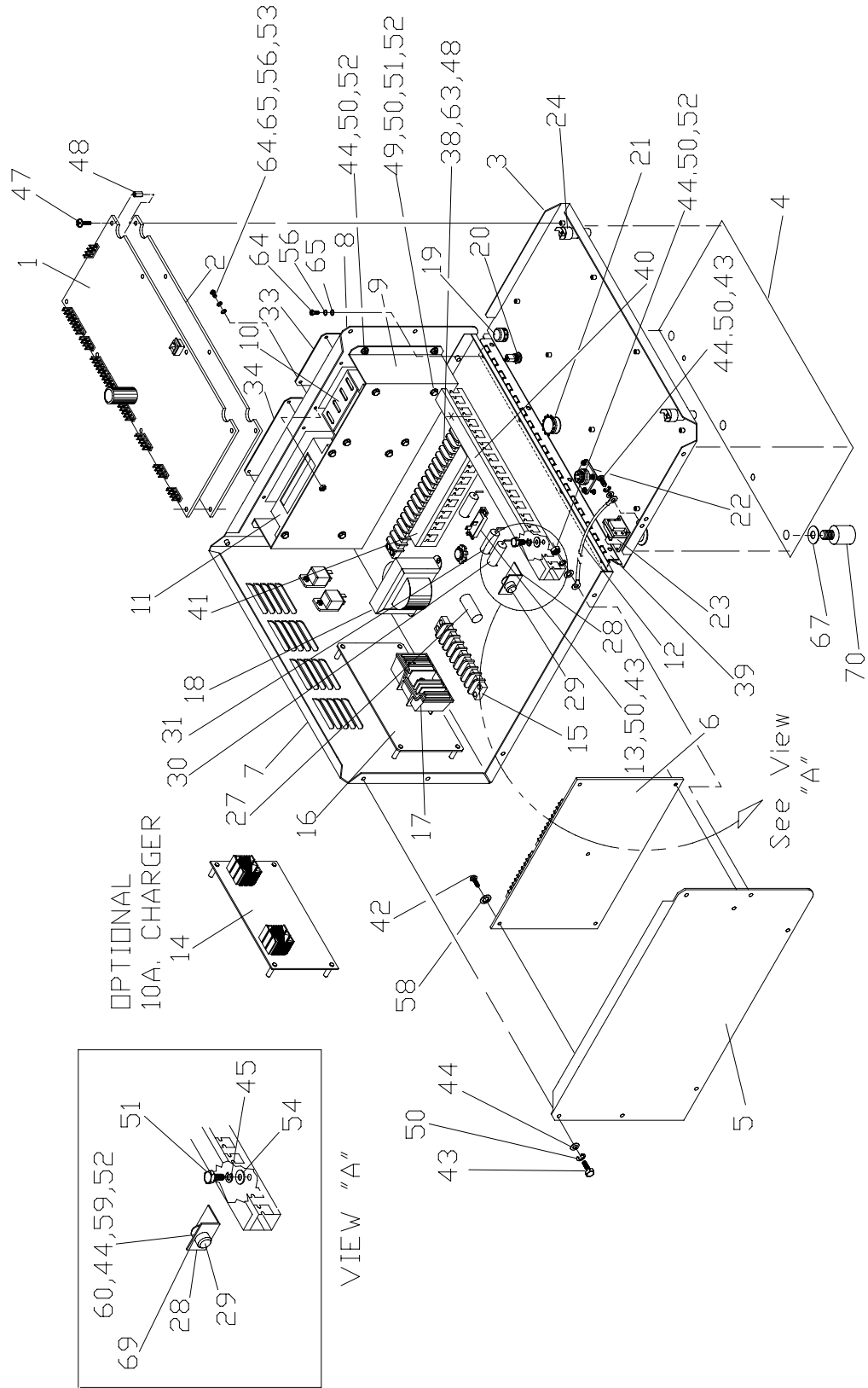

EXPLODED VIEW —CONTROL PANEL
Drawing No. A3103

| ITEM | PART NO. A1695 | PART NO. A1695A | QTY. | DESCRIPTION | ITEM | PART NO. A1695 | PART NO. A1695A | QTY. | DESCRIPTION |
|------|-------------------|--------------------|------|-----------------------------|------|-------------------|--------------------|------|------------------------------|
| 1 | A1053 | A1053 | 1 | CPU BOARD | 35 | A1666 | A1666 | 1 | FRONT PANEL HARNESS |
| 2 | A1056 | A1056 | 1 | DISPLAY BOARD | 36 | A1667 | A1667 | 1 | MAIN HARNESS |
| 3 | A1057 | A2274 | 1 | FRONT PANEL | 37 | A2566 | A2566A | 1 | INTERCONNECTING HARNESS |
| 4 | A1057A | A1057A | 1 | OVERLAY | 38 | 57335 | 57335 | 1 | MAIN TERMINAL BLOCK |
| 5 | A1437 | A2277 | 1 | LEFT HAND PANEL | 39 | 21985 | A2273 | 1 | HINGE |
| 6 | A1054 | A1054A | 1 | INTERFACE BOARD | 40 | A2400 | A2400 | 1 | TRUNKING |
| 7 | A1436 | A1436 | 1 | PANEL/BACK BOTTOM | 41 | A2400A | A2400A | 1 | TRUNKING |
| 8 | A1438 | A1438 | 1 | RIGHT HAND PANEL | 42 | 20752 | 20752 | 5 | 4-40 x 1/4-PPMS |
| 9 | A1440 | A1440 | 1 | AVR/GOV. CHASSIS | 43 | 33121 | 33121 | 15 | 10-32 x 1/2-HHMS |
| 10 | SEE TABLE C | - | - | AVR ASSEMBLY | 44 | 23897 | 23897 | 21 | FLAT WASHER #10 |
| 11 | SEE TABLE C | - | - | OPTIONAL ELEC. GOV. | 45 | 22097 | 22097 | 4 | LOCK WASHER 1/4 |
| 12 | A2275 | A2275 | 1 | FRONT PANEL STAY | 46 | | | 1 | LOW COOLANT BURDEN RESI9STER |
| 13 | SEE TABLE B | - | - | SEE TABLE B | 47 | 29606 | 29606 | 9 | 6-32 x 1/4-PHMS |
| 14 | SEE TABLE D | - | - | SEE TABLE D | 48 | 22155 | 22155 | 12 | LOCK WASHER #6 |
| 15 | 79524 | 79524 | 1 | BATT. CHARGER TERM. | 49 | 22188 | 22188 | 2 | HEX NUT 6-32 |
| 16 | A1439 | A1439 | 1 | 2A. CHARGER CHASSIS | 50 | 22152 | 22152 | 20 | LOCK WASHER #10 |
| 17 | SEE TABLE D | - | - | 2A. BATTERY CHARGER | 51 | 22287 | 22287 | 4 | 1/4-20 x 3/4-HHCS |
| 18 | SEE TABLE D | - | - | 2A. CHARGER TRANSFORMER | 52 | 22158 | 22158 | 6 | HEX NUT 10-32 |
| 19 | 71361 | 71361 | 1 | VOLTAGE TRIM POTENTIOMETER | 53 | 22471 | 22471 | 4 | HEX NUT 8-32 |
| 20 | 32300 | 32300 | 1 | 15A. FUSE HOLDER | 54 | 22473 | 22473 | 4 | FLAT WASHER 1/4 |
| | 22676 | 22676 | 1 | FUSE (NOT SHOWN) | 55 | 36261 | 36261 | 4 | POP RIVETS |
| 21 | A3033 | A3033 | 1 | PLANT CONTROL SWITCH | 56 | 22264 | 22264 | 4 | LOCK WASHER #8 |
| 22 | A3034 | A3034 | 1 | RS-232 CONNECTOR | 57 | 22985 | 22985 | 2 | FLAT WASHER #6 |
| 23 | 61129 | 98426A | 1 | EMERGENCY STOP P.B. | 58 | 23364 | 23364 | 8 | SHAKEPROOF INT. #6 |
| | NOT USED | 98426C | 1 | CONTACTS (NOT SHOWN) | 59 | 23762 | 23762 | 1 | SHAKEPROOF EXT. #10 |
| 24 | A3035 | A3035 | 2 | PANEL LAMPS | 60 | 30468 | 30468 | 1 | STEP WASHER-NYLON |
| 25 | A2560 | A2560 | 1 | STARTER RELAY (12V.) | 61 | 34616 | 34616 | 1 | STRAIGHT RELIEF |
| 26 | A2560 | A2560 | 1 | PRE-HEAT RELAY (12V.) | 62 | 36901 | 36901 | 8 | 6-32 x 3/8-PPHMS |
| 27 | A3036 | NOT USED | 1 | RESERVOIR CAPACITOR | 63 | 36909 | 36909 | 4 | 6-32 x 1-PPHMS |
| 28 | 55444 | 55444 | 1 | HEAT SINK (DIODE) | 64 | 36918 | 36918 | 8 | 8-32 x 1/2-PPHMS |
| 29 | 49939 | 49939 | 1 | FIELD BOOST DIODE | 65 | 38150 | 38150 | 8 | FLAT WASHER #8 |
| 30 | SEE TABLE A | - | - | FIELD BOOST RESISTOR | 66 | 39271 | 39271 | 1 | 90 DEG. STRAIN RELIEF |
| 31 | 44213 | 44213 | 1 | CAPACITOR, EXCITER RESISTOR | 67 | 47246 | 47246 | 8 | FLAT WASHER SPECIAL |
| | | | | RESISTOR | 68 | 64733 | 64733 | 4 | MOUNTING BRACKET |
| 32 | 25192 | 25192 | 1 | CHARGE ALT. EXCITER DIODE | 69 | 70370 | 70370 | 2 | WASHER-MICA |
| | | | | DIODE | 70 | 40479 | 40479 | 4 | VIBRATION DAMPNER |
| 33 | A1441B | A1441B | 1 | AUR COVER PLATE | | | | | |
| 34 | A1441A | A1441A | 1 | GOV. COVER PLATE | | | | | |

TABLE A-FIELD BOOST RESISTOR DATA

| | |
|--|---------------------------|
| ALL DIRECTLY EXCITED MACHINES UP TO 100KW WITH 12 OR 24V DC SYSTEMS | 5 OHM 25W P/N - 48352 |
| ALL BRUSHLESS MACHINES UP TO 100KW WITH 12V DC SYSTEMS | 25 OHM 25W P/N - 57405 |
| ALL BRUSHLESS MACHINES UP TO 100KW WITH 24V DC SYSTEMS | 50 OHM 25W P/N - 83364 |
| ALL BRUSHLESS MACHINES OVER 100KW 12 OR 24V DC SYSTEMS | 75 OHM 25W P/N - 86266 |

TABLE B - AVR POWER (DPE) CIRCUIT BREAKER DATA

| | |
|---|---------------------|
| ALL DIRECTLY EXCITED MACHINES 19 TO 45KW | 7A P/N - 48467 |
| ALL BRUSHLESS MACHINES 19 TO 26KW | 5.5A P/N - 54450 |
| ALL BRUSHLESS MACHINES 29 TO 41KW | 6.0A P/N - 48505 |
| ALL BRUSHLESS MACHINES 45 TO 100KW | 4.5A P/N - 48476 |
| ALL MACHINES OVER 100KW | 4.5A P/N - 48476 |

TABLE C-AVR/ELECTRONIC GOVERNOR CONTROLLER DATA

| | |
|---|-------------|
| ALL 60HZ MACHINES WITH GENERAC ALTERNATORS USE VOLTAGE REGULATOR | P/N - 67680 |
| ALL 50HZ MACHINES WITH GENERAC ALTERNATORS USE VOLTAGE REGULATOR | P/N - 92952 |
| BARBER COLMAN 12V 2500-5000HZ ELECTRONIC GOVERNOR CONTROLLER | P/N - 67709 |
| BARBER COLMAN 24V 2500-5000HZ ELECTRONIC GOVERNOR CONTROLLER | P/N - 67710 |
| BARBER COLMAN 12V 5000-9500HZ ELECTRONIC GOVERNOR CONTROLLER | P/N - 67711 |

TABLE D - BATTERY CHARGER OPTIONS

| DC VOLTAGE | RATED 2A | RATED 10A |
|------------|-------------|-------------|
| 12V | P/N - A3104 | P/N - A3105 |
| 24V | P/N - A3105 | P/N - A3107 |

NOTE - A MINIMUM 2A CHARGER MUST BE SUPPLIED

