

GENERAC®

POWER SYSTEMS, INC.

Owner's and Installation Manual

DG 50 Genset
Liquid-cooled, Gas Engine
Generator Set

Models:

04311-0 (50 kW/208V/Three-phase)

04313-0 (50 kW/480V/Three-phase)

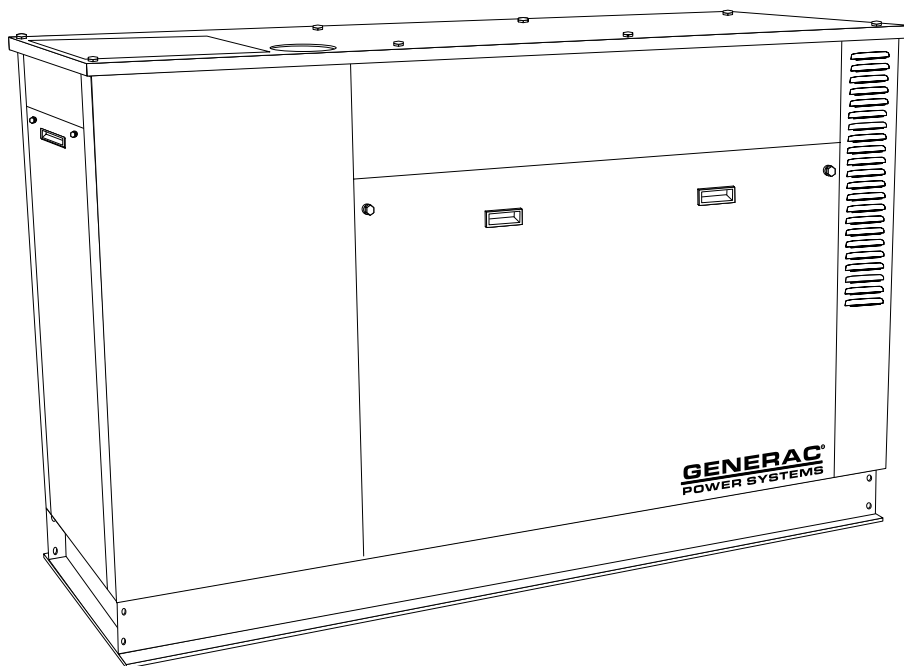

—▲ **DANGER** ▲—

**ONLY QUALIFIED ELECTRICIANS OR CONTRACTORS
SHOULD ATTEMPT INSTALLATION!!**

INTRODUCTION

The DG 50 is a self contained paralleling generator set, capable of supplying 50kW either as a standby generator, or, in parallel with the existing utility supply. This means it can be used to reduce the energy consumption from the utility company (by up to 50kW) when required (Base Loading mode). The unit can be put in parallel from either the front panel, a contact closure or via one of its communication channels.

In conjunction with an optional "Peak Shave Module", one or many units can be used to automatically reduce peak loading on the utility, thus avoiding the expensive penalties involved. The Peak Shave module can be programmed to operate in many different modes - base load daily, multiple times daily, work days only or, in Peak Shave mode to limit the utility loading to a programmable fixed value. Generator Power Factor can also be controlled from this module.

Both the DG 50 and the Peak Shave Module have multiple communication facilities. The stand alone DG 50 can be connected to a modem and communicate to a remote PC using Generac's proprietary software package "Genlink". The unit can also communicate concurrently with building management systems using the industry standard Modbus protocol. In either case, Engine status and health monitoring can be performed and the unit started (and stopped) in parallel mode.

The Peak Shave module can communicate with multiple generator sets on one site, then in turn, it can communicate this information to both a remote PC (Via modem; US Robotics V90 56K Sportster is recommended. See GenLink manual for proper setup.) and a building management system. In this case the Peak Shave module acts as a relay station between the DG 50's and the communicating devices.

◆ READ THIS MANUAL THOROUGHLY

If you do not understand any portion of this manual, contact Generac or your nearest Generac Authorized Dealer for starting, operating and servicing procedures.

Throughout this publication, and on tags and decals affixed to the generator, DANGER, WARNING, CAUTION and NOTE blocks are used to alert you to special instruction about a particular operation that may be hazardous if performed incorrectly or carelessly. Observe them carefully. Their definitions are as follows:



After this heading, you can read instructions that, if not strictly complied with, will result in personal injury or property damage.



After this heading, you can read instructions that, if not strictly complied with, may result in personal injury or property damage.



After this heading, you can read instructions that, if not strictly complied with, could result in damage to equipment and/or property.

NOTE:

After this heading, you can read explanatory statements that require special emphasis.

Generac® Power Systems, Inc.

These safety warnings cannot eliminate the hazards that they indicate. Common sense and strict compliance with the special instructions while performing the service are essential to preventing accidents.

Four commonly used safety symbols accompany the DANGER, WARNING and CAUTION blocks. The type of information each indicates is as follows:

 This symbol points out important safety information that, if not followed, could endanger personal safety and/or property of you and others.

 This symbol points out potential explosion hazard.

 This symbol points out potential fire hazard.

 This symbol points out potential electrical shock hazard.

The operator is responsible for proper and safe use of the equipment. We strongly recommend that the operator read this *Owner's Manual* and thoroughly understand all instructions before using this equipment. We also strongly recommend instructing other users to properly start and operate the unit. This prepares them if they need to operate the equipment in an emergency.

◆ CONTENTS

This manual contains pertinent owner's information, including warranty, electrical diagrams, exploded views and lists of repair parts, for the following models: 04311-0 and 04313-0

◆ OPERATION AND MAINTENANCE

It is the operator's responsibility to perform all safety checks, to make sure that all maintenance for safe operation is performed promptly, and to have the equipment checked periodically by a Generac Authorized Dealer. Normal maintenance service and replacement of maintenance parts are the responsibility of the owner/operator and, as such, are not considered defects in materials or workmanship within the terms of the warranty. Individual operating habits and usage contribute to the need for maintenance service.

Proper maintenance and care of your generator ensure a minimum number of problems and keep operating expenses at a minimum. See your Generac Authorized Dealer for service aids and accessories.

◆ HOW TO OBTAIN SERVICE

When your generator requires servicing or repairs, simply contact a Generac Authorized Dealer for assistance. Service technicians are factory-trained and are capable of handling all of your service needs.

When contacting a Generac Authorized Dealer or the factory about parts and service, always supply the complete model number and serial number of your unit as given on its data decal, which is located on your generator.

Model No. _____ Serial No. _____

AUTHORIZED DEALER LOCATION

To locate the GENERAC AUTHORIZED DEALER nearest you, please call:

1-800-333-1322

or visit our website at:
www.GENERAC.com

Introduction.....Inside Front Cover	
Read This Manual Thoroughly	IFC
Contents	IFC
Operation and Maintenance	IFC
How to Obtain Service	IFC
Authorized Dealer Locator Number	IFC
Safety Rules.....2	
Section 1 – General Information4	
1.1 Unpacking/Inspection	4
1.1.1 Lifting the Generator	4
1.2 Generator AC Connection Systems.....4	
1.3 Customer Terminal Block Connections	4
1.4 Specifications	5
1.4.1 Generator	5
1.4.2 Engine	5
1.5 Fuel Requirements and Recommendations.....5	
1.6 Engine Oil Requirements	5
1.7 The Battery.....5	
1.8 The AVR Power Module	6
1.9 The Throttle Actuator Module	6
1.10 The Overspeed Module	6
1.11 The Watchdog Module	6
1.12 The Battery Charger	6
1.13 The Exerciser Module.....7	
Section 2 – Operation.....7	
2.1 Control Console Components	7
2.1.1 Off	7
2.1.2 Manual	7
2.1.3 Automatic	7
2.2 Keypad	7
2.3 Display	9
2.3.1 Software Version Screen	9
2.3.2 Generator Command Screen	9
2.3.3 Generator Status Screen	9
2.3.4 Alarm Status Message Screen	9
2.3.5 Instrumentation Screen	9
2.3.6 Parameter Entry Screen	9
2.3.7 Alarm Log Screen.....10	
2.4 Alarms	10
2.4.1 Alarm Types	10
2.4.2 Activity Settings	10
2.5 Responding to Alarms	10
2.5.1 Accepting an Alarm.....10	
2.5.2 Clearing an Alarm.....10	
2.6 Alarm Type	10
2.6.1 Common Alarm Relay	10
2.6.2 Warning — Non-Latched	11
2.6.3 Alarm — Latched	11
2.6.4 Shutdown	11
2.7 Programmable Parameters	12
2.7.1 Preheat Enabled.....12	
2.7.2 Preheat Time	12
2.7.3 Exercise Options	12
2.7.4 User Password	12
2.7.5 Panel ID	12
2.7.6 Restore Defaults.....12	
2.7.7 Running Hours.....12	
2.7.8 Flywheel Teeth	12
2.7.9 Starter Disengage Speed	12
2.7.10 Number of Start Attempts	12
2.7.11 Start Timer	12
2.7.12 Start Attempt Pause Time	12
2.7.13 Cool Down Time	12
2.7.14 Warm Up Time.....13	
2.7.15 Alarm Hold Off Time	13
2.8 Programmable AVR Parameters	13
2.8.1 Power Output Setpoint Source	13
2.8.2 Generator Voltage Calibration	13
2.8.3 Utility Voltage Calibration.....13	
2.8.4 Power Factor	13
2.8.5 Power Output Setpoint.....13	
2.9 Governor Parameters	13
2.9.1 Gain	13
2.9.2 Stability	13
2.9.3 Differential	13
2.10 Droop Gain.....13	
2.11 Droop Select.....13	
2.12 Under Frequency Slope	14
2.13 Under Frequency Corner	14
2.14 Voltage Stability and Gain.....14	
2.14.1 Stability	14
2.14.2 Gain	14
2.15 Frequency Setpoint.....14	
2.16 AC Voltage Setpoint	14
2.17 Programmable Alarm Setpoints	14
2.17.1 Oil Pressure Alarms	14
2.17.2 Oil Temperature Alarms.....14	
2.17.3 Coolant Temperature Alarms	14
2.17.4 Battery Voltage Alarms	14
2.17.5 Engine Speed Alarms	14
2.17.6 Generator Voltage Alarms	15
2.17.7 Generator Frequency Alarms	15
2.17.8 Fuel Level Alarms.....15	
2.17.9 Overcrank Alarms	15
2.17.10 Coolant Level Alarm	15
2.17.11 Transfer Error Alarms	15
2.17.12 Internal Communication Alarm	16
2.18 Parallel Operation.....16	
2.18.1 Setting Up	16
2.18.2 Remote Parallel Operation (GenLink).....16	
2.18.3 Parallel Errors	16
2.18.4 Loss of Utility in Parallel	16
2.19 Serial Communications	16
2.19.1 GenLink	16
2.19.2 Remote Annunciator-Relay Panels	17
2.19.3 Building Management.....17	
2.19.4 Method of Connection	17
2.20 Additional Standard Components	17
2.20.1 Line Phase Selector Switch	17
2.20.2 AC Voltmeter	17
2.20.3 AC Ammeter.....17	
2.20.4 DC Panel Fuse	17
2.20.5 Emergency Stop Switch	17
2.20.6 Parallel Switch	18
2.21 The Transfer Switch	18
2.22 The Checksynch board.....18	
2.23 Relay Protection Scheme	19
Section 3 – Maintenance.....20	
3.1 Checking the Engine Oil Level	20
3.2 Changing the Engine Oil and Filter.....20	
3.2.1 Engine Oil Requirements	20
3.2.2 Oil and Filter Change Procedure	20
3.3 Changing the Engine Air Cleaner	21
3.4 Spark Plugs	21
3.5 Battery Maintenance.....21	
3.6 Cooling System.....22	
3.6.1 Engine Heater	22
3.7 Overload Protection for Engine DC Electrical System ..22	
3.7.1 Fuse	23
3.8 Engine Coolant	23
3.9 Miscellaneous Maintenance	23
3.9.1 Cleaning the Generator	23
3.9.2 Cleaning the Radiator.....23	
3.9.3 Rodent Protection.....23	
3.10 Out of Service Procedure	23
3.10.1 Removal From Service	23
3.11 Service Schedule	24
Section 4 – Troubleshooting.....25	
4.1 Troubleshooting Guide	25
Section 5 – Notes	26
Appendix 1 – Standard Configurations	27
Appendix 2 – F Panel Operations Display Map.....28	
Section 6 – Electrical Data	30
Section 7 – Exploded Views and Parts Lists.....37	
Section 8 – Warranty	Back Cover



! SAVE THESE INSTRUCTIONS – The manufacturer suggests that these rules for safe operation be copied and posted in potential hazard areas. Safety should be stressed to all operators and potential operators of this equipment. **!**

— **! DANGER !** —

! Utility voltage is present within the control cabinets of this unit. Unit should only be serviced by authorized personnel.

! WARNING: !

The engine exhaust from this product contains chemicals known to the state of California to cause cancer, birth defects or other reproductive harm.

! WARNING: !

This product contains or emits chemicals known to the state of California to cause cancer, birth defects or other reproductive harm.

Study these SAFETY RULES carefully before installing, operating or servicing this equipment. Become familiar with this *Owner's Manual* and with the unit. The generator can operate safely, efficiently and reliably only if it is properly installed, operated and maintained. Many accidents are caused by failing to follow simple and fundamental rules or precautions.

Generac cannot possibly anticipate every possible circumstance that might involve a hazard. The warnings in this manual, and on tags and decals affixed to the unit are, therefore, not all-inclusive. If you use a procedure, work method or operating technique Generac does not specifically recommend, you must satisfy yourself that it is safe for you and others. You also must make sure the procedure, work method or operating technique that you choose does not render the generator unsafe.

— **! DANGER !** —

! Despite the safe design of this generator, operating this equipment imprudently, neglecting its maintenance or being careless can cause possible injury or death. Permit only responsible and capable persons to operate or maintain this equipment.

! Potentially lethal voltages are generated by these machines. Ensure all steps are taken to render the machine safe before attempting to work on the generator.

! Parts of the generator are rotating and/or hot during operation. Exercise care near running generators.

! GENERAL HAZARDS !

- For safety reasons, Generac requires that the installation, initial start-up and maintenance of this equipment is carried out by a Generac Authorized Dealer.
- The engine exhaust fumes contain carbon monoxide, which can be DEADLY. This dangerous gas, if breathed in sufficient concentrations, can cause unconsciousness or even death. This exhaust system must be installed properly, in strict compliance with applicable codes and standards. Following installation, you must do nothing that might render the system unsafe or in noncompliance with such codes and standards.
- Keep hands, feet, clothing, etc., away from drive belts, fans, and other moving or hot parts. Never operate the unit with any drive belt or fan guard removed.
- Adequate, unobstructed flow of cooling and ventilating air is critical to correct generator operation. Do not alter the installation or permit even partial blockage of ventilation provisions, as this can seriously affect safe operation of the generator.
- When working on this equipment, remain alert at all times. Never work on the equipment when you are physically or mentally fatigued.
- Inspect the generator regularly, and repair or replace all damaged or defective parts immediately. Always use factory-authorized parts.
- Turn off the AC power to the battery charger before disconnecting the battery to minimize the chance of equipment damage.
- Before performing any maintenance on the generator, disconnect its battery cables to prevent accidental start-up. Disconnect the cable from the battery post indicated by a NEGATIVE, NEG or (–) first. Reconnect that cable last.
- Never use the generator or any of its parts as a step. Stepping on the unit can stress and break parts, and may result in dangerous operating conditions from leaking exhaust gases, fuel leakage, oil leakage, etc.



ELECTRICAL HAZARDS

- All generators covered by this manual produce dangerous electrical voltages and can cause fatal electrical shock. Utility power delivers extremely high and dangerous voltages to the transfer switch as does the standby generator when it is in operation. Avoid contact with bare wires, terminals, connections, etc., while the unit is running. Ensure all appropriate covers, guards and barriers are in place before operating the generator. If you must work around an operating unit, stand on an insulated, dry surface to reduce shock hazard.
- Do not handle any kind of electrical device while standing in water, while barefoot, or while hands or feet are wet. **DANGEROUS ELECTRICAL SHOCK MAY RESULT.**
- The National Electrical Code (NEC) requires the frame and external electrically conductive parts of the generator to be connected to an approved earth ground. Local electrical codes also may require proper grounding of the generator electrical system.
- After installing this standby electrical system, the generator may crank and start at any time without warning. When this occurs, load circuits are transferred to the STANDBY (generator) power source. To prevent possible injury if such a start and transfer occur, always set the generator's Auto/Off/Manual switch to its OFF position before working on equipment and remove the 15A fuse in front panel.
- In case of accident caused by electric shock, immediately shut down the source of electrical power. If this is not possible, attempt to free the victim from the live conductor. **AVOID DIRECT CONTACT WITH THE VICTIM.** Use a nonconducting implement, such as a rope or board, to free the victim from the live conductor. If the victim is unconscious, apply first aid and get immediate medical help.
- Never wear jewelry when working on this equipment. Jewelry can conduct electricity resulting in electric shock, or may get caught in moving components causing injury.

FIRE HAZARDS

- For fire safety, the generator must be installed and maintained properly. Installation always must comply with applicable codes, standards, laws and regulations. Adhere strictly to local, state and national electrical and building codes. Comply with regulations the Occupational Safety and Health Administration (OSHA) has established. Also, ensure that the generator is installed in accordance with the manufacturer's instructions and recommendations. Following proper installation, do nothing that might alter a safe installation and render the unit in noncompliance with the aforementioned codes, standards, laws and regulations.
- Keep a fire extinguisher near the generator at all times. Extinguishers rated "ABC" by the National Fire Protection Association are appropriate for use on the standby electric system. Keep the extinguisher properly charged and be familiar with its use. If you have any question pertaining to fire extinguishers, consult your local fire department.

EXPLOSION HAZARDS

- Do not smoke around the generator. Wipe up any fuel or oil spills immediately. Ensure that no combustible materials are left in the generator compartment, or on or near the generator, as FIRE or EXPLOSION may result. Keep the area surrounding the generator clean and free from debris.
- Gaseous fluids such as natural gas are extremely EXPLOSIVE. Install the fuel supply system according to applicable fuel-gas codes. Before placing the standby electric system into service, fuel system lines must be properly purged and leak tested according to applicable code. After installation, you must inspect the fuel system periodically for leaks. No leakage is permitted.

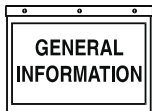

1.1 UNPACKING/INSPECTION

After unpacking, carefully inspect the contents for damage.

- This standby generator set has been factory installed in an all-weather, metal enclosure that is intended exclusively for outdoor installation.

If any loss or damage is noted at time of delivery, have the person(s) making the delivery note all damage on the freight bill or affix their signature under the consignor's memo of loss or damage. Cosignee is responsible to claim any shipping loss or damage with the shipper.

If you note loss or damage after delivery, separate the damaged materials and contact the carrier for claim procedures.

“Concealed damage” is understood to mean damage to the contents of a package that is not in evidence at the time of delivery, but is discovered later.

◆ 1.1.1 LIFTING THE GENERATOR



When lifting or hoisting equipment is used, be careful not to touch overhead power lines.

The generator's weight of more than 2,000 pounds requires proper tools and equipment, and qualified personnel to be used in all phases of handling and unpacking.

1.2 GENERATOR AC CONNECTION SYSTEMS

Three-phase generators are shipped from the factory with their stator AC output leads connected as low wye or high wye depending on configuration. This type of connection system will supply a 208 or 480-volt, three-phase output.

1.3 CUSTOMER TERMINAL BLOCK CONNECTIONS

There are two terminal blocks for customer connections. One terminal block is located inside the transfer switch enclosure immediately beneath the transfer switch (TB1). **DO NOT ENTER THIS ENCLOSURE WITH UTILITY VOLTAGE PRESENT OR WITH BATTERY POWER ON THE GENERATOR.** Terminal 1 is at the left hand end of the terminal block. The following user connections can be made to this terminal block for 120V AC utility for the jacket water heater and battery charger:

- Terminal 14 - Earth
- Terminal 15 - Neutral
- Terminal 16 - Live

The second terminal block is located on the left wall of the same enclosure (TB3) with terminal 1 located at the bottom. The following user connections can be made to this terminal block:

- Terminal 2,3 - Remote emergency stop switch (normally closed contact).
- Terminal 4,5 - Remote parallel switch (normally open contact). This duplicates the front panel parallel switch, the generator can be started and go into parallel from either switch.
- Terminal 6,8 - RS485 — (minus) communications port connection.
- Terminal 7,9 - RS485 + (plus) communications port connection. Use twisted pair shielded cable for this connection with the shield going to terminal 4 (earth). This is for connecting to the Peak Shave module, remote annunciator/relay panel or GenLink. See “Serial Connection - Method of Connection”.
- Terminal 10 - RS232 common communications port connection.
- Terminal 11 - RS232 tx communications port connection.
- Terminal 12 - RS232 rx communications port connection. Use 3 core shielded cable for this connection with the shield going to terminal 4 (earth). This is for connecting to the remote annunciator/relay panel or GenLink. See “Serial Connection - Method of Connection”.

1.4 SPECIFICATIONS

◆ 1.4.1 GENERATOR

Model.....	04311-0/04313-0
Rated Maximum Continuous AC Power Output (kW)*	50
Rated Voltage (volts).....	208/480
Rated Maximum Continuous Current at	
208 Volts, Three-phase (amps)	173
480 Volts, Three-phase (amps)	75
Number of Rotor Poles	4
Driven Speed of Rotor (rpm)	1,800
Type of Stator	12-wire Reconnectable
Rotor Excitation System	Brushless
Rotor and Stator Insulation	Class "H"

*Rated power of generator is subject to and limited by such factors as ambient temperature, altitude, engine condition and other factors. Engine power will decrease about 3.5 percent for each 1,000 feet above sea level; and also will decrease an additional 1 percent for each 12° C (10° F) above 15.5° C (60° F). Maximum output power of the generator is limited by maximum engine power.

◆ 1.4.2 ENGINE

Make	Generac
Displacement	5.7 liters (350 cu. in.)
Cylinder Arrangement	V-8
Bore	4.0 in. (101.6 mm)
Stroke	3.48 in. (88.4 mm)
Firing Order	1-8-4-3-6-5-7-2
Number of Main Bearings	5
Compression Ratio	9.4-to-1
No. of Teeth on Flywheel	168
Intake Air	Naturally Aspirated
Connecting Rods	Steel
Cylinder Head	Cast Iron
Pistons.....	Aluminum Alloy
Crankshaft	Iron
Ignition System	Electronic
Ignition Timing at 1,800 rpm	35 degrees BTDC
Rated Horsepower at 1,800 rpm.....	67
Spark Plug Gap	0.035 inch (.89 mm)
Recommended Spark Plugs.....	A/C Delco
Oil Pressure	50 psi
Total Oil Capacity	45 U.S. quarts (42.58 L)
Required Engine Oil	Penzoil Geo 15W-40
Type of Cooling System	Pressurized, closed recovery
Cooling Fan	Puller Type
Cooling System Capacity.....	5.5 U.S. gallons (20.8 L)
Recommended Coolant	Use a 50-50 mixture of ethylene glycol and soft water.

Fuel Consumption

Natural Gas	
04311-0	850 cfh
04313-0	850 cfh

NOTE:

Fuel consumption is given at rated maximum continuous power output when using natural gas rated at 1,000 Btu per cubic foot. Actual fuel consumption obtained may vary depending on such variables as applied load, ambient temperature, engine conditions and other environmental factors.

1.5 FUEL REQUIREMENTS AND RECOMMENDATIONS

Recommended fuels should have a Btu content of at least 1,000 Btus per cubic foot for natural gas. Ask your fuel supplier for the Btu content of your fuel.

Fuel pressure for natural gas is 11 inches to 14 inches of water column (0.6 psi) at all load ranges.

—▲ WARNING ▲—

▲ Gaseous fuels such as natural gas are highly explosive. Even the slightest spark can ignite such fuels and cause an explosion. No leakage of fuel is permitted. Natural gas, which is lighter than air, tends to collect in high areas; LP gas is heavier than air and tends to settle in low areas – install and use leak detectors accordingly.

1.6 ENGINE OIL REQUIREMENTS

Generac requires the DG 50 to be serviced using Penzoil Geo 15W-40 engine oil. Use of any other oil will invalidate lubrication related warranty claims.

—▲ CAUTION ▲—

▲ Any attempt to crank or start the engine before it has been properly serviced with the required oil may result in an engine failure.

1.7 THE BATTERY

Use a 12-volt, automotive-type storage battery (Group 27F) rated 90 amp hours or more and capable of a minimum of 600 cold-cranking amps at -17.8° C (0° F). Check the specific gravity and electrolyte levels at the intervals specified in the service schedule (Section 3.11). When using maintenance free batteries these procedures are not necessary. A negative ground system is used. Battery connections are shown on the wiring diagrams. Make sure the battery is correctly connected and terminals are tight. Observe battery polarity when connecting the battery to the generator set. Disconnect the cable from the negative (-) terminal first. Reconnect the negative (-) terminal last.

NOTE:

Damage may result if the battery connections are made in reverse.

Your generator is equipped with a battery trickle charger that is active when your unit is set up for automatic operation. The trickle charge is designed to help extend the life of your battery by maintaining the battery when the unit is not running.

—  **DANGER**  —

 Storage batteries give off explosive hydrogen gas. This gas can form an explosive mixture around the battery for several hours after charging. The slightest spark can ignite the gas and cause an explosion. Such an explosion can shatter the battery and cause blindness or other injury. Any area that houses a storage battery must be properly ventilated. Do not allow smoking, open flame, sparks or any spark producing tools or equipment near the battery. Disconnect the cable from the battery post indicated by a **NEGATIVE, NEG** or **(-)** first. Reconnect the **NEGATIVE** cable last.

 Battery electrolyte fluid is an extremely caustic sulfuric acid solution that can cause severe burns. Do not permit fluid to contact eyes, skin, clothing, painted surfaces, etc. Wear protective goggles, protective clothing and gloves when handling a battery. If you spill the fluid, flush the affected area immediately with clear water.

—  **WARNING**  —

 Do not dispose of the battery in a fire. The battery is capable of exploding.

 Do not open or mutilate the battery. Released electrolyte can be toxic and harmful to the skin and eyes.

 The battery represents a risk of high short circuit current. When working on the battery, always remove watches, rings or other metal objects, and only use tools that have insulated handles.

1.8 THE AVR POWER MODULE

This module is located on the outside of the control box, on the left, if looking from the battery side of the DG 50 (10 wires total).

The AVR Power Module houses the power electronics that drive the field of the alternator. The actual field control is done in the F panel and the signals are converted to power levels by this unit. It controls the output voltage and voltage stability of the generator. Stability and dynamic response can be adjusted via the front panel keyboard and display. (Dynamic response means how well the module responds to rapidly changing loads).

1.9 THE THROTTLE ACTUATOR MODULE

This module is located on the outside of the control box, in the middle, if looking from the battery side of the DG50 (5 wires total).

The Throttle Actuator Module houses the power electronics that drive the actuator module. The actual control is done inside of the F panel and the signals are converted to power levels by this unit. The module operates the throttle for the engine and controls the engine speed and stability. Stability and dynamic response can be adjusted via the front panel keyboard and display. Nominally the engine speed is controlled to give a 60Hz output, but this can be altered to 50Hz (or other speed) via the front panel.

1.10 THE OVERSPEED MODULE

The Overspeed module is located on the rear of the control panel door, to the right of the exerciser. It can be identified by the relay on the board. Access is gained via a special cabinet key. **HIGH VOLTAGES ARE PRESENT IN THIS CABINET.** Observe the safety rules.

The Overspeed module provides a secondary check on the engine speed. Normally the F panel will stop the engine (by cutting the fuel) if it overspeeds. If the F panel fails to stop the engine for some reason, the overspeed module will stop the engine if it reaches 2550 RPM.

1.11 THE WATCHDOG MODULE

The Watchdog module is located on the rear of the control panel door, to the right and below the exerciser. It can be identified by the Green LED on the board. Access is gained via a special cabinet key. **HIGH VOLTAGES ARE PRESENT IN THIS CABINET. OBSERVE THE SAFETY RULES.**

The watchdog module is present to keep an eye on the F panel. If it fails, it will stop the engine or prevent it from starting via the emergency stop circuit. The display, if still operable, will show - "Emergency Stop".

1.12 THE BATTERY CHARGER

This module is located on the outside of the control box, on the right, if looking from the battery side of the DG 50 (4 wires total).

It is capable of supplying up to 2.5A into the battery. It is powered from a 120 VAC standard utility supply which has to be wired into the generator on the customer terminal block connections.

1.13 THE EXERCISER MODULE

The Exerciser module is located on the rear of the control panel door. It can be identified by the clock display.

Access is gained via a special cabinet key. HIGH VOLTAGES ARE PRESENT IN THIS CABINET. Observe the safety rules. See the exerciser manual for operational details.

2.1 CONTROL CONSOLE COMPONENTS

The F panel control module performs all of the control functions within the DG 50. It controls engine starting and stopping, engine speed, output voltage and frequency, monitors engine performance, and decides when to operate the transfer switch. It can communicate with remote devices via communication ports. See Figures 2.1 and 2.2.

Figure 2.1 — Location of Control Console

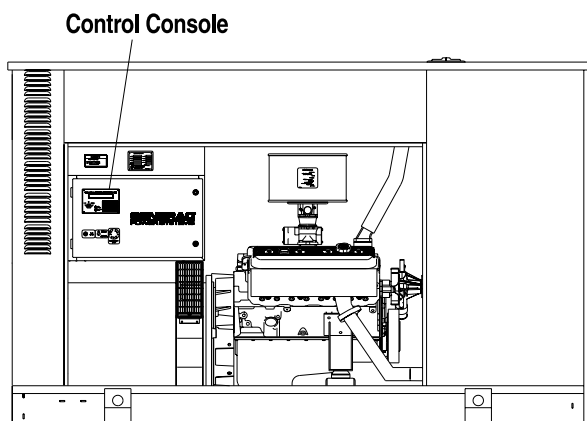

The front panel of the unit acts as the interface to the user. By means of a backlit 24 character LCD and a 6 key keypad, the user can examine data monitored by the unit and change parameters within the unit. In conjunction with the Emergency stop switch and the Parallel switch, the keyswitch can be used to start and stop the genset. The keyswitch allows the unit to be put into one of three modes.

◆ 2.1.1 OFF

In this mode, the generator will not start.

◆ 2.1.2 MANUAL

In manual mode, the generator will start immediately without altering the state of the transfer switch. If utility power fails while in manual mode, the breakers will not open. This prevents deadbus/checksynch problems. Manual mode is for limited testing of the unit.

◆ 2.1.3 AUTOMATIC

In automatic mode, as the name suggests, the generator will start automatically when power from the utility supply fails. You can also put the generator into parallel mode via the front panel toggle switch, remote contacts, or via the communication channels. Automatic is the normal mode of operation.

REFER TO THE "F PANEL OPERATIONS FLOW-CHART" (on page 8) for details about what the panel will do when power from the utility supply fails in each of the above keyswitch positions.

Figure 2.2 — Control Console

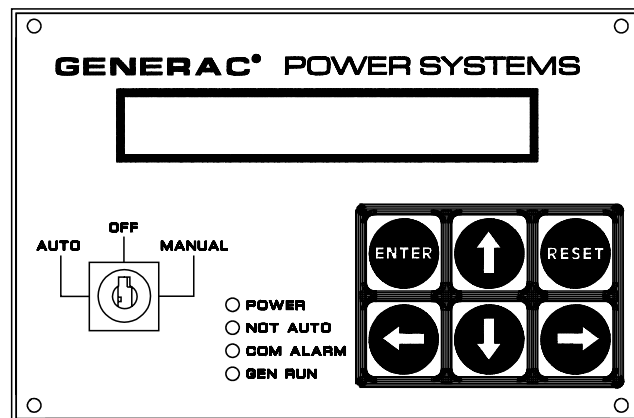

2.2 KEYPAD

The keypad consists of six keys labeled as follows:
↑ (Up), ↓ (Down), ← (Left), → (Right), Enter and Reset.

The left and right arrow keys are used to select the different pages on the display. The up and down arrow keys are used to scroll between options within a page. They are also used for selecting options when the user enters parameters into the unit. The enter key takes the user into a page on the display to change data (when applicable) and also accepts data that has been entered. It is also used to accept an alarm. The reset key ignores data that has been entered and returns the original value. It is also used to return from the parameter entry mode once the user has finished changing the data, and to reset any latched alarms that have been cleared.

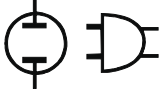

“F” PANEL OPERATIONS CHART

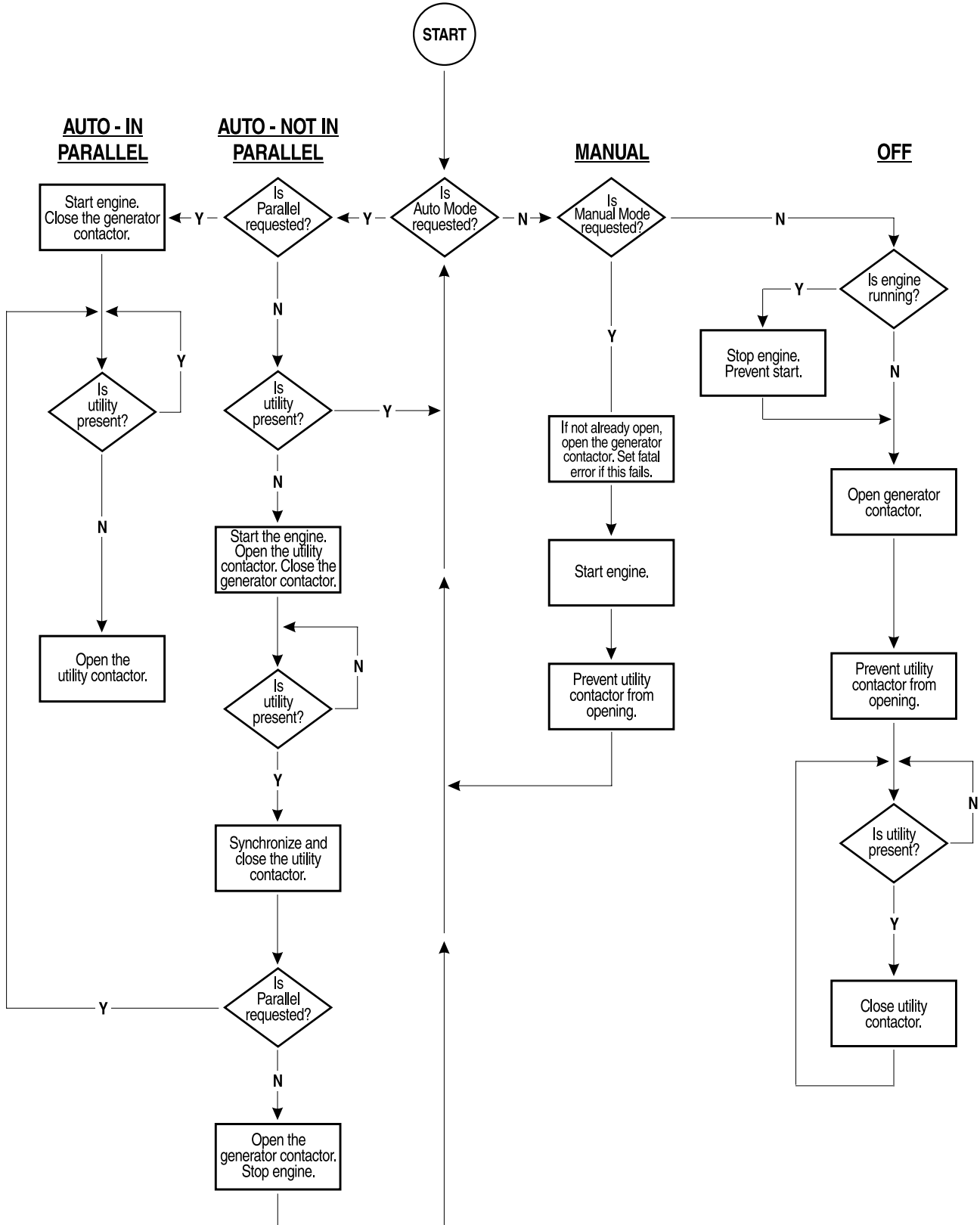



2.3 DISPLAY

The display is organized into a series of screens, each screen displays information about the status of the generator. For example, the "Alarm Status Message Screen" displays the highest priority current alarm or status condition. The user will be able to scroll between the screens using the left and right arrow keys. Certain actions also cause the display to change screens (e.g. when an alarm becomes active, the display automatically will go to the alarm status screen and display the alarm message).

The back light for the display is normally off. If the user presses any key, the back light will come on automatically and remain on for five minutes after the last key was pressed. It will also flash if any alarm is active.

When the display is showing certain screens, the user is able to scroll between relevant items within the screen using the up/down arrow keys. For example, if the display is showing the alarm status screen, the user can scroll between the current alarms with the up/down arrow keys.

A description of each screen is given below.

◆ 2.3.1 SOFTWARE VERSION SCREEN

This screen displays the software revision. Pressing the enter key in this screen will perform a display and LED test.

◆ 2.3.2 GENERATOR COMMAND SCREEN

This screen displays the command sent to the generator. The possible commands are as follows:

- Generator switched off
- Generator in manual mode
- Generator in auto mode - stop command
- Generator in auto mode - remote run command
- Generator in auto mode - serial link run command

◆ 2.3.3 GENERATOR STATUS SCREEN

This screen displays the current status of the generator. Options will be as follows:

- Stopped - ready to run
- Stopped - start inhibit active
- Pre-heating (with timer counting down)
- Attempting to start (with timer counting down and number of attempts)
- Pausing before start attempt (with timer counting down and number of attempts)
- Started - running up to speed
- Warming up
- Ready to accept load
- All alarms enabled
- Cooling down
- Stopping
- Stopped due to alarm

If the user has not pressed a key for some time, any change in status will cause this screen to be displayed provided that there are no active alarms or status messages from other inputs. If an alarm condition occurs, the alarm status screen will be displayed automatically.

◆ 2.3.4 ALARM STATUS MESSAGE SCREEN

This screen displays alarm messages and programmable status messages. Messages are displayed according to priority, with the shutdown alarms having highest priority, and status messages having lowest priority.

If an alarm becomes active, the display will switch to this screen and display the highest priority alarm message. The back light and alarm LED will flash. The user must press the enter key to accept the alarm, at which time the back light will be on continuously. If the alarm is non-latching, the alarm message will clear as soon as the condition is cleared. If the alarm is a latching alarm, then the user must press the reset key to clear the message. Once a message has cleared, the display will show the next priority alarm message.

After an alarm has been accepted (see Section 2.5.1 on page 10), the user is able to scroll through other active alarm and message screens using the up and down arrow keys.

◆ 2.3.5 INSTRUMENTATION SCREEN

This screen displays one of the analog signal values. Pressing the up or down arrow keys will scroll to other analog display screens. Refer to the F PANEL DISPLAY MAP (Appendix 2) to see the displayable readings and how to get to them.

◆ 2.3.6 PARAMETER ENTRY SCREEN

This screen allows the user to modify the various set points and programmable options. See the "Programmable Parameters" (Section 2.7, page 11) of this manual for more specific option information. The user must press the Enter key when this screen is displayed and will be prompted for a password. The password is a six-digit number and the default value is 000000. However, the user will be able to change the password. Digits are selected by using the up and down arrow keys, and the cursor is moved by using the left and right arrow keys. When the user presses the Enter key, the password will be checked. If the password is correct, the display will show one of the data entry screens.

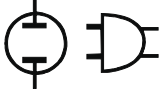

There are three parameter entry menus: "Engine Parameters", "System Alarm", and "AVR Parameters". The user will be able to scroll through the various parameters in each menu using the up and down arrow keys. The left and right arrow keys are used to switch between the four menus. When a parameter that requires changing is displayed, the user presses the Enter key to enable data entry. A cursor will appear at the first character that can be altered. The user can then change the character using the up and down arrow keys. The user can move to the next character or previous character using the left and right arrow keys. Pressing the Enter key will accept the new setting. Pressing the Reset key will ignore the new setting.

If an alarm condition occurs when the user is entering data, the data will be ignored, and the display will show the alarm screen. If a status condition occurs when data is being entered, the display will not change.

Once the user has finished entering data by pressing the Enter key, pressing the Reset key will allow the user to select other screens using the left and right arrow keys.

◆ 2.3.7 ALARM LOG SCREEN

The alarm log screen will display the last alarm logged. The last 19 alarms will be stored in memory. You can scroll through these with the up or down arrow keys.

Each alarm is logged with additional information about the state of the utility voltage, generator voltage, etc., at the time of the alarm. The display will cycle through these readings for the currently displayed alarm.

2.4 ALARMS

The DG 50 has a built-in alarm system to alert service personnel of operational conditions which require attention. See Section 2.5 for instructions on how to respond to these alarms. There are three basic types and three different activity settings as described below.

◆ 2.4.1 ALARM TYPES

- Non-latching — These alarms clear themselves once the alarm condition has ended.
- Latching — These alarms must be manually cleared even after the alarm condition has ended.
- Shutdown — Similar to latching alarms but they shut down operation of the unit and can only be reset by turning off the keyswitch.

◆ 2.4.2 ACTIVITY SETTINGS

- Always — This setting leaves the alarm always active even when the unit is not operating.
- Immediate — This setting leave the alarm inactive when the unit is not running but it becomes active as soon as the unit starts to crank and remains active until the unit stops.
- Hold Off — Similar to Immediate except that there is a programmable delay after startup before the alarm becomes active. The same delay time applies to all Hold Off type alarms.

2.5 RESPONDING TO ALARMS

◆ 2.5.1 ACCEPTING AN ALARM

When an alarm condition occurs, the alarm LED and the display backlight start flashing. If an audible alarm is installed, a common alarm relay closes causing a tone to sound. The audible tone and the flashing backlight are turned off by accepting the alarm using the "Enter" key on the keypad. The alarm LED will then change to steady and any audible alarm will be silenced.

◆ 2.5.2 CLEARING AN ALARM

For non-latching alarms, the alarm is cleared when the condition is no longer present. Latching alarms must be cleared by pressing the reset key if the alarm condition is no longer present. Shutdown alarms can only be cleared by turning the keyswitch to the off position.

2.6 ALARM TYPE

◆ 2.6.1 COMMON ALARM RELAY

The internal control box (F Panel) contains a relay which operates on any Alarm or Warning. The contacts of this relay all rated at 10A 227 VAC and 10A 30 VDC resistive. The contacts are available for customer connections to screw terminals on the back of the F Panel (Figure 2.3). There are 3 voltage-free connections:

- J6-9 — Normally Open
- J6-8 — Common
- J6-10 — Normally Closed

Figure 2.3 — Rear View of F Panel

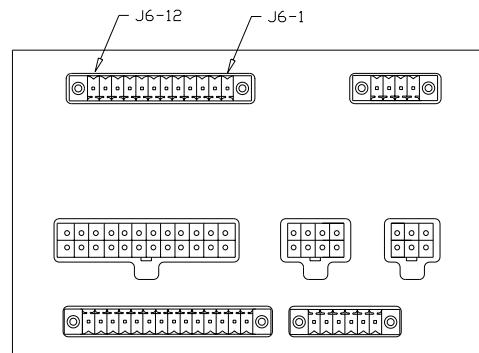

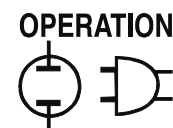

ALARMS

Alarm Message	Alarm Active	Alarm Type
Pre-Low Oil Pressure Warning	Hold Off	Non-Latch
Low Oil Pressure shutdown Alarm	Hold Off	Shutdown
Pre-High Coolant Temp. Warning	Hold Off	Non-Latch
High Coolant Temp. Shutdown Alarm	Hold Off	Shutdown
Low Coolant Temp. Warning	Always	Non-Latch
Pre-High Oil Temp. Warning	Immediate	Non-Latch
High Oil Temp. shutdown Alarm	Hold Off	Shutdown
Low Battery Voltage Warning*	Always	Non-Latch
Overspeed Alarm	Immediate	Shutdown
Underspeed	Hold Off	Latch
Overcrank Alarm	Immediate	Shutdown
Over Voltage	Hold Off	Shutdown
Under Voltage	Hold Off	Shutdown
Over Frequency	Hold Off	Shutdown
Under Frequency	Hold Off	Shutdown
High Fuel Warning	Always	Non-Latch
Low Fuel Warning	Always	Non-Latch
Critical Low Fuel Shutdown Alarm	Always	Shutdown
Low Coolant Level Alarm	Hold Off	Shutdown
Emergency Stop	Always	Shutdown
RPM Sensor Failure Alarm	Always	Shutdown
Start Inhibit – Oil Pressure	Immediate	Shutdown
Oil Pressure Sensor Failure	Always	Shutdown
Oil Temp. Sensor Failure	Always, Disabled	Shutdown
Coolant Temp. Sensor Failure	Always	Shutdown
High Battery Voltage Warning	Always	Non-Latch
Transfer Switch Fault	Always	Shutdown
Internal Communications Fault	Always	Shutdown

* Battery voltage must be below alarm limit for 5 minutes to trigger alarm.

◆ 2.6.2 WARNING - NON-LATCHED

This type of warning will activate the common alarm relay and flash the alarm LED and display back light. The associated message will be displayed on the screen. When the user accepts the warning (by pressing the Enter key), the back light will stop flashing, and the alarm LED will be on continuously. The message will be displayed on the alarm screen, but the user will be able to scroll through other screens. The LED and message will clear when the warning condition clears or is cleared.

◆ 2.6.3 ALARM - LATCHED

This type of alarm will act similarly to the non-latched warning, except that the alarm does not clear when the alarm condition clears. When the alarm condition occurs, the audible alarm sounds, the LED and back light flash as before, and the user must accept the alarm (see Section 2.5.1) to stop them.

The alarm will continue to be displayed on the screen even after the alarm condition has cleared. The user must either press the Reset key or turn the key-switch to the OFF position to clear the alarm after the alarm condition has cleared. The common alarm relay will activate.

◆ 2.6.4 SHUTDOWN

This type of alarm will act similar to the latched alarm but it also will stop the engine when the alarm condition occurs. It can be reset only by turning the key-switch to the OFF position. All shutdown alarms are latching. The common alarm relay will activate.

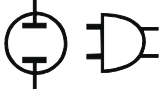

2.7 PROGRAMMABLE PARAMETERS

The F option panel allows the user to configure various options to control the generator starting and stopping cycles, alarm setpoints and operating settings for the generator. Parameters are entered either from the control module or via the serial link. A description of the programmable parameters follows.

◆ 2.7.1 PREHEAT ENABLED

This parameter determines how the preheat function works. The preheat can be fully disabled, enabled before starting only (for the duration of the preheat time), or before and during starting (for the duration of the preheat time and also while the starter is engaged). Note that if the user wishes to engage the preheat during starting but not to have a preheat before starting, it is possible to set the preheat time to zero.

◆ 2.7.2 PREHEAT TIME

When a start command is received, the engine may require preheating before the generator attempts to start. If the preheat function is enabled, this parameter allows the user to determine the time that the preheat contact closes before activating the starter solenoid.

◆ 2.7.3 EXERCISE OPTIONS

This parameter allows you to decide whether to simply run the engine when exercising the unit or to also do a transfer and run in parallel. Running in parallel also tests and exercises the transfer switch. Exercise times are set from the exerciser module.

◆ 2.7.4 USER PASSWORD

The user can set the password. This is a six-digit number and is set to 000000 at the factory.

◆ 2.7.5 PANEL ID

Each panel can have a unique six digit ID number. This allows the unit to be identified from GenLink and also from the peak shave module. In multiple generator installations with peak shave attached, separate Id's are necessary to allow the peak shave module (and GenLink, version 5.36 and above) to route the data to the correct generator. The number is initially programmed to 000000 and can be altered by the user/installer. In a multi generator configuration, the installer will set up these "addresses" and they SHOULD NOT BE CHANGED BY THE USER. Changing them will render the generator unusable by the peak shave module.

◆ 2.7.6 RESTORE DEFAULTS

By selecting this option, the factory set default parameters (as listed in the appendix) will be loaded into the parameters, overwriting the existing values. This should only be necessary if you have lost all the parameters.

◆ 2.7.7 RUNNING HOURS

The F panel keeps track of how many hours the engine has been running. This is displayed in hours and tenths of hours. Any run of less than 6 minutes duration will not be recorded. This parameter is for display only.

◆ 2.7.8 FLYWHEEL TEETH

This parameter holds the number of flywheel teeth. This value is used to determine the engine speed from the magnetic pickup signal.

◆ 2.7.9 STARTER DISENGAGE SPEED

This is the speed at which the engine should be self sustaining and the point at which the starter disengages. It is changeable by the user and is normally set to 500rpm.

◆ 2.7.10 NUMBER OF START ATTEMPTS

This parameter will determine how many times the engine will crank in an attempt to start the engine. For example, if it is set to two (2), the engine will crank two (2) times with a pause in between each crank cycle. If it fails to start, an overcrank alarm will be displayed.

◆ 2.7.11 START TIMER

Once a start command has been received and the preheat time has expired (if enabled), the starter solenoid will be engaged. This parameter allows the user to determine how long the starter solenoid is engaged before the start attempt is regarded as having failed. If the generator does not start within this time, the generator will wait for a preset time before attempting to start again. The user also can program the number of start attempts.

◆ 2.7.12 START ATTEMPT PAUSE TIME

If the generator does not start within the programmed start time, it will pause before trying to start again. This parameter determines the length of that pause.

◆ 2.7.13 COOL DOWN TIME

This parameter determines the length of time that the generator continues to run after a stop command is sent in AUTO mode in order to cool down the engine with no load.

Note:

If the key-switch is turned to the OFF position when the generator is running, it will stop immediately regardless of this setting.

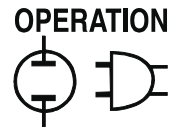

◆ 2.7.14 WARM UP TIME

Some applications require that the generator run for a given time before a load is applied. This parameter allows the user to set that time. Normally it will be set to zero seconds. The generator is ready to accept load when this timer expires.

◆ 2.7.15 ALARM HOLD OFF TIME

Once the engine has started, some alarm functions (such as low oil pressure and under speed) are not activated immediately since the engine must be given time to reach a stable condition. This parameter determines the time that elapses before the hold off alarms are activated.

2.8 PROGRAMMABLE AVR PARAMETERS

◆ 2.8.1 POWER OUTPUT SETPOINT SOURCE

This parameter allows you to select where the power setpoint comes from. The setpoint can be an analog input (0-5V) or can be set as a fixed value in the AVR parameters. When a peak shave module is connected and you are operating in peak shave mode, any power demands it sends to the generator will override all other power settings.

◆ 2.8.2 GENERATOR VOLTAGE CALIBRATION

This setting allows you to calibrate the generator voltage against a calibrated meter. Its range is 0.900 to 1.100. If you set the AC voltage setpoint to be 480 VAC say, and the meter shows 490 VAC, then INCREASE the scaling factor until the output voltage is correct. The reverse applies to a low voltage. The calibration is normally done at the factory. Correct readings are important to minimize circulating currents at the moment of paralleling.

◆ 2.8.3 UTILITY VOLTAGE CALIBRATION

This setting allows you to calibrate the utility voltage against a calibrated meter. Its range is 0.900 to 1.100. For example if the utility AC voltage is 480 VAC, and the meter shows 490 VAC, then DECREASE the scaling factor until the output voltage is correct. The reverse applies to a low voltage. This method is the opposite of calibrating the generator voltage. The calibration is normally done at the factory. Correct readings are important to minimize circulating currents at the moment of paralleling.

◆ 2.8.4 POWER FACTOR

In parallel mode, the power factor of the generator can be set by this value. If a peak shave module is connected, it will then override this setting if operating in peak shave mode. The power factor can be set from 80 to 100 representing 0.8 to 1.00 lagging.

◆ 2.8.5 POWER OUTPUT SETPOINT

This parameter should be programmed to the desired power output of the generator in parallel mode. It cannot affect the generator when operating in standby or when peak shaving. It can be programmed from 0-50kw but note that at low powers, the power factor will not be tightly held. The power output setpoint source should be set to "on screen"

2.9 GOVERNOR PARAMETERS

These parameters adjust the stability and dynamic frequency (and to some extent voltage) response of the generator to changing loads IN STANDBY MODE ONLY. They are normally factory set and should not need altering.

◆ 2.9.1 GAIN

Increase this value to speed up the response but not so much as to make the unit unstable. Ensure the unit is still stable at all loads when testing new values.

◆ 2.9.2 STABILITY

Increase this value to stabilize the frequency reading but reduce the dynamic response. Ensure the unit is still stable at all loads when testing new values.

◆ 2.9.3 DIFFERENTIAL

Increase this value to improve the dynamic response. Ensure the unit is still stable at all loads when testing new values.

2.10 DROOP GAIN

NOT USED. RESERVED FOR FUTURE USE.

2.11 DROOP SELECT

NOT USED. RESERVED FOR FUTURE USE.

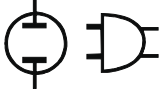

2.12 UNDER FREQUENCY SLOPE

This parameter controls the output voltage roll off when the generator is suddenly loaded such that its frequency temporarily drops. To allow the generator to recover, it drops its voltage and thus power output until the frequency recovers. The amount by which it drops voltage is proportional to the drop in frequency below the under frequency corner. The amount is controlled by this parameter which can be set from 1 to 3 where 1 is the smallest amount. It is factory preset and should only need changing if the generator struggles to recover from a sudden load application.

2.13 UNDER FREQUENCY CORNER

This is the frequency below which the generator will shed output volts to allow it to recover from a large sudden load application (as described as above). It is factory preset and should only need changing if the generator struggles to recover from a sudden load application.

2.14 VOLTAGE STABILITY AND GAIN

These parameters adjust the stability and dynamic voltage response of the generator to changing loads IN STANDBY MODE ONLY. They are normally factory set and should not need altering.

◆ 2.14.1 STABILITY

This parameter affects the stability of the generators output voltage. Increasing this parameter, improves the stability but may adversely affect load dumps or block loads. Ensure the unit is still stable at all loads when testing new values.

◆ 2.14.2 GAIN

This parameter improves the dynamic response of the generator to a changing load. Increasing this value improves the response. Ensure the unit is still stable at all loads when testing new values.

2.15 FREQUENCY SETPOINT

This parameter sets the nominal output frequency in standby mode only.

2.16 AC VOLTAGE SETPOINT

This parameter sets the nominal output AC voltage in standby mode only.

2.17 PROGRAMMABLE ALARM SETPOINTS

◆ 2.17.1 OIL PRESSURE ALARMS

The oil pressure input has two associated alarm functions. Both only operate after the hold off time has expired and both operate the common alarm relay. The pre-oil pressure warning is a non-latched, hold off alarm with a user-definable set-point. The low oil pressure shutdown alarm has a user definable set-point and will shut down the generator. The shutdown alarm set-point should be the lowest of the two settings so that the user will have some warning of a low oil condition before the generator is shut down.

◆ 2.17.2 OIL TEMPERATURE ALARMS

The oil temperature has two associated alarm functions. The oil temperature warning is a non-latched, immediate alarm. The oil temperature shutdown is a shutdown alarm that operates after the hold off time. Both alarm functions have programmable set-points and both operate the common alarm relay.

◆ 2.17.3 COOLANT TEMPERATURE ALARMS

The coolant temperature input has three associated alarms. The pre-high coolant temperature alarm is a non-latched, hold off alarm. The high coolant temperature alarm is a shutdown alarm that operates after the hold off time. The low coolant temperature warning is a non-latching, always active alarm. Set-points for each alarm are programmable. The alarms operate the common alarm relay.

◆ 2.17.4 BATTERY VOLTAGE ALARMS

The low battery voltage warning set-point is programmable. The warning will be activated if the battery voltage is below this value for more than five minutes. This is a non-latched, always active alarm. The "Power" LED on the front panel will not be lit if the battery voltage is less than this value. The high battery voltage alarm set-point is also programmable. The warning is active immediately when the battery voltage is higher than this value. The alarms operate the common alarm relay.

◆ 2.17.5 ENGINE SPEED ALARMS

The user can program the overspeed and the underspeed alarms. The overspeed alarm is an immediate shutdown alarm. Underspeed is a latched, hold off alarm. The alarms operate the common alarm relay.

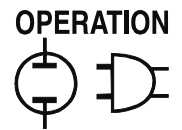

◆ 2.17.6 GENERATOR VOLTAGE ALARMS

A hold off alarm can be generated for high voltage and low voltage. The set-points are user-definable, and the alarms are shutdown alarms that operate after the hold off time. The alarms operate the common alarm relay.

◆ 2.17.7 GENERATOR FREQUENCY ALARMS

A hold off alarm can be generated for high frequency and low frequency. The set-points are user-definable, and the alarms are shutdown alarms that operate after the hold off time. The alarms operate the common alarm relay.

◆ 2.17.8 FUEL LEVEL ALARMS

The fuel level sensor has three associated alarms. The high fuel and low fuel warning alarms are non-latching, always active alarms with user-definable set-points. The critical low fuel shutdown alarm is always active and is a shutdown alarm. The alarms operate the common alarm relay.

◆ 2.17.9 OVERCRANK ALARM

This alarm is unlike other alarms as it is not associated with an analog or digital signal. The user is able to define the number of crank attempts, the length of each crank attempt and the rest time between cranks. After the last start attempt has been made, an overcrank alarm will be generated. The alarm operates the common alarm relay.

◆ 2.17.10 COOLANT LEVEL ALARM

This alarm is generated by the coolant level detector. This device senses whether coolant is present or not. It has no user-definable level setting and is a shutdown alarm that is active after the hold off time. There are no user-definable parameters for this alarm. The alarm operates the common alarm relay.

◆ 2.17.11 TRANSFER ERROR ALARMS

If the transfer switch fails or the unit fails to go into parallel, a transfer error alarm will be displayed and the generator shut down. The alarms operate the common alarm relay. See the table below for an explanation.

TRANSFER ERROR ALARMS

Transfer Error	Meaning	Possible Cause
1	Gen contactor failed to trip	The auxiliary contact on the breaker may be faulty. The breaker may be faulty . The interposing relays may be faulty. The voltage may be low.
2	Gen contactor failed to close	The auxiliary contact on the breaker may be faulty. The breaker may be faulty . The interposing relays may be faulty. The voltage may be low. The checksynch board may be faulty.
3	Utility contactor failed to close	The auxiliary contact on the breaker may be faulty. The breaker may be faulty . The interposing relays may be faulty. The voltage may be low. The checksynch board may be faulty.
4	Utility contactor failed to trip	The auxiliary contact on the breaker may be faulty. The breaker may be faulty . The interposing relays may be faulty. The voltage may be low.
5	Utility contactor failed to home	NOT CURRENTLY USED
6	Gen contactor failed to home	NOT CURRENTLY USED
7	Synchronizer timeout	Failed to sync in time with the utility. The controller may be faulty. The checksynch board may be faulty. The wiring may be faulty. A relay may be faulty. The throttle control may be unstable.
8	Negative power fault	Power flowed into the generator. Check the Current Transformer, ensure unit can run at full power in standby.
9	Engine fault	The engine stopped for another unrelated alarm. Examine the active alarms on the screen.
10	MCB open	The main circuit breaker is open, reset.
11	Contactor failed to latch	Mechanical problem with the breaker, it bounced in and out. Check it's mechanical adjustment.
15	Indeterminate fault	Failed to close on the the breakers on mutiple retries.

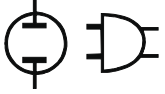

◆ 2.17.12 INTERNAL COMMUNICATION ALARM

If this alarm is displayed and cannot be reset, the control panel is faulty and should be replaced. The alarm operates the common alarm relay and is a shutdown alarm.

2.18 PARALLEL OPERATION

The DG 50 is capable of running in parallel with the utility supply (its output can be directly connected to the utility supply via the transfer switch). In order to do this, the output voltage, frequency and phase of the generator must match that of the utility. When the unit is commanded to "parallel", the control system matches all of these parameters and then closes the transfer switch onto the utility. It then acts simply as a power generator. The power the unit produces and the power factor are programmable via the LCD screen. The power can also be programmed to take it's setpoint from an analog (0-5V) input. Tolerances for paralleling (8 cycles) are:

- less than $\pm 6V$ difference
- less than ± 0.5 Hz difference
- less than $\pm 10^\circ$ synch difference

◆ 2.18.1 SETTING UP

Put the keyswitch in the OFF position and the parallel switch in the off (DOWN) position. Ensure the unit main circuit breaker is closed and that utility power is present. You can confirm this by looking at the utility voltage reading on the LCD panel. Ensure that the voltage readings have been calibrated (this is normally done at the factory). To do this, check that the actual generator voltage and utility voltage agree with the readout on the LCD display. If not, refer to the Programmable AVR parameters section - generator and utility voltage calibration.

To set up for parallel operation enter the required power and power factor into the unit. Go to the parameter entry page and then select "AVR PARAMETERS". First ensure that power is selected to come from "on screen" parameters and not from an analogue (0-5V) source. Set the power you require (0-50kw) then set the power factor (80 - 100 is 0.8 to 1.0 pf). Turn the keyswitch to the AUTO position, the unit should not start. Put the parallel toggle switch in the on position (UP), the engine will start and take several seconds to sync to the utility. The transfer switch will then close and power will slowly build up to the programmed level. You can see this by looking at the measured power (or current) on the screen. The measured power factor can also be seen on the screen. Note that at low power settings (less than 10kW) the power factor will not be tightly held.

◆ 2.18.2 REMOTE PARALLEL OPERATION (GENLINK)

The Generator can be put into parallel operation mode by using the PC based communication package - GenLink (version 5.36 and above). The same rules apply in this case as for local operation provided the keyswitch switch is in auto mode. See the GenLink manual for details on how to run GenLink. Connect the PC either directly to the serial port via the cable (optionally supplied), or connect the port to a modem (cable optionally supplied). See manual "Modbus for the DG 50" (part number D2901) for serial port and modem. Go to the parameters menu and enter the desired power, power factor and select "on screen" as the power source. On the main screen start the generator via the start button. When the generator has started, press the parallel button. Time will pass and the generator will get in sync and the transfer switch will close into parallel. You will see the power and power factor displayed on the GenLink screen. To exit parallel, press the stop button. If you exit GenLink while still in parallel, the unit will continue to parallel, if GenLink accidentally disconnects, the unit will exit the parallel mode and the engine will stop. The utility breaker will remain closed, supplying utility power to the load.

◆ 2.18.3 PARALLEL ERRORS

If the unit fails to parallel for any reason, a transfer error will be displayed. The table on page 15 lists the current errors and their possible causes.

◆ 2.18.4 LOSS OF UTILITY IN PARALLEL

If utility power is lost while in parallel, the unit will revert to standby operation. When utility power returns, the unit will return to parallel operation. Losing utility power also encompasses losing one phase, low or high utility voltage (10%) or poor utility frequency. See the "F panel operations flowchart" (pages 28-29) for more detail.

2.19 SERIAL COMMUNICATIONS

The control panel has both an RS232 and an RS485 communication port. Both of these ports can be used at the same time to communicate with various devices. Unless a remote annunciator or relay panel is configured to be connected to a port, all communications use the industry standard Modbus protocol (in binary format).

◆ 2.19.1 GENLINK

The control panel can communicate with GenLink (version 5.36 and above), which is a PC based program allowing both the interrogation of the generator and remote alteration of its parameters. The user will be able to start and stop the generator if it is in AUTO mode. GenLink communications can be either local via a serial link, or remote via a modem and can be connected to either port. If a modem is used, the control panel communications parameters must be set to "modem."

◆ 2.19.2 REMOTE ANNUNCIATOR-RELAY PANELS

The serial connections can be configured to allow the control panel to connect to remote annunciators and/or remote relay panels, on either port. If the RS232 port is used, an RS232 to RS485 converter box will be required. More than one RAP/RRP can be connected to the port in daisy chain fashion. See the Remote Annunciator Manual for connection details.

◆ 2.19.3 BUILDING MANAGEMENT

The control panel can be connected to a building management system to allow interrogation and alteration of the internal parameters. The generator can be started from this connection if the keyswitch is in the auto position. All communication uses Modbus protocol. See the document "Modbus for the DG 50" (Generac part number D2901) for connections and protocol details.

◆ 2.19.4 METHOD OF CONNECTION

If a peak shave module is connected to the generator, it will use the RS485 port. GenLink will communicate with the panel via the peak shave unit. Multiple generator sets can be linked to the peak shave unit via this port, and GenLink can interrogate each one individually. If a remote annunciator or remote relay panel is required, it will be connected to the RS232 port (via a 232/485 converter). In this way each unit can have a separate annunciator. GenLink could also communicate locally via a laptop to the RS232 port (if no other devices are connected) but this is not recommended. A building management system would connect to the peak shave module via a separate RS485 port on the peak shave module. If GenLink is not being used, it could be connected to the RS232 port but this is not recommended.

If no peak shave module is connected then the RS485 port is used for the remote devices (annunciator or relay) and the RS232 port is used for GenLink (via modem or serially). A building management system can connect to either of the ports provided there is nothing else connected to it. It can be used to duplicate the remote annunciator or relay panel if required (via PLC). See the document "Modbus for the DG 50" (Generac part number D2901) for connections and protocol details.

2.20 ADDITIONAL STANDARD COMPONENTS

◆ 2.20.1 LINE PHASE SELECTOR SWITCH

The line phase selector switch is located next to the panel meters on the back of the transfer switch box. It allows you to select which phase to monitor with the panel meters. See Figure 2.4.

◆ 2.20.2 AC VOLTMETER

This meter indicates the generator AC output voltage. By using the line phase selector switch mounted next to the meter, you can view A - B, B - C and C - A voltage. To determine the nominal rated AC voltage of your unit, refer to your unit's data plate. See Figure 2.4.

◆ 2.20.3 AC AMMETER

This meter indicates the current draw of connected electrical loads, in amps. Also see "Line-phase Selector Switch (Section 2.20.1)." For continuous operation, never exceed the rated maximum continuous current capacity of your generator. The meter is connected to the load side of the transfer switch and thus will NOT indicate power flowing back into the utility when in parallel mode. See Figure 2.4.

Figure 2.4 — Line Phase Selector Switch, AC Voltmeter & AC Ammeter

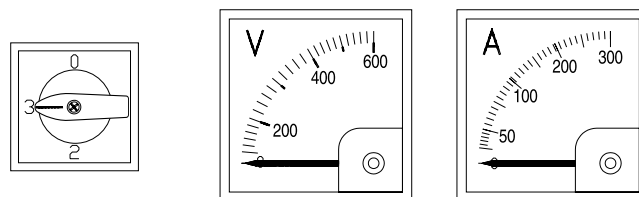

◆ 2.20.4 DC PANEL FUSE

This 15-amp fuse protects the panel components. This fuse is not to be confused with the control module internal fuse discussed in "Checking/Replacing the F Panel Control Module Internal Fuse." See Figure 2.5 on page 18.

◆ 2.20.5 EMERGENCY STOP SWITCH

When pressed, this switch will automatically shut down the entire generator set. The operator must twist and pull the switch out to its original position to reset it and allow for generator operation.

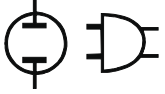

◆ 2.20.6 PARALLEL SWITCH

This switch is only effective when the keyswitch is in the AUTO position. It is on when toggled to the UP position. The switch commands the generator to start and parallel with the utility. It will generate a fixed amount of power as programmed in the AVR parameters menu. This power will either be supplied to a connected load or exported back to the utility company. For example, if you have selected 50KW to be generated and only have a 10KW load, then 10KW will go to the load and 40KW back to the utility.

Figure 2.5 — DC Panel Fuse, Emergency Stop Switch & Parallel Switch

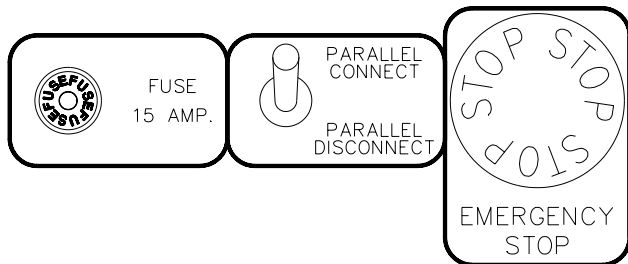

2.21 THE TRANSFER SWITCH

The Transfer Switch is located on the opposite side of the genset to the control panel. Access is made by removing the bolted cover from the box. UNDER NO CIRCUMSTANCES SHOULD THE COVER BE REMOVED WITH LIVE UTILITY PRESENT OR THE GENSET RUNNING. Observe the safety rules.

The transfer switch consists of two 200A contactors which can close either utility supply or generator supply to the load. In paralleling mode, both utility and generator can be closed to the load (and thus to each other). The transfer switch is operated via 240 VAC (nominal) solenoid coils which derive their power from the appropriate live source. The generator supply can only be closed to the load if the generator is running. Similarly, the utility can only be closed to the load if utility is live. The generator can only be tripped from the load if the utility is live, and the utility can only be tripped if the generator is live.

The coils are operated by interposing relay logic in the control cabinet and are ultimately controlled from the F panel.

The status of the two switches is fed back via auxiliary contacts to the F panel, which uses these signals to indicate any fault conditions.

As described in section 2.18, synchronizing is performed (when necessary) by the F panel itself, with the checksynch board providing a secondary safety check.

Open and closed indication is provided by an indicator on the front of the switch. The switches can be manually operated with an actuator lever which is located on the base of the transfer switch enclosure. You cannot close both the utility and generator switches at the same time. The switches can also be manually tripped by depressing the metal pins located in the holes on the transfer switch cover.

Connection of the load is via the three terminals T1,T2,T3 marked "customer load" - on the base and to the rear of the transfer switch. Polarity of this connection may be important so OBSERVE PHASE ROTATION when connecting to these terminals.

Connection of the utility is via the three terminals N1,N2,N3 marked "normal supply" -on the top of the transfer switch. Polarity of this connection IS important so OBSERVE CORRECT PHASE ROTATION when connecting to these terminals.

2.22 THE CHECKSYNCH BOARD

This module is located on the floor of the control box, behind the control panel. Access is gained via a special cabinet key. HIGH VOLTAGES ARE PRESENT IN THIS CABINET. Observe the safety rules.

The Checksynch Board provides a secondary level of protection when the controller is trying to close the transfer switches. Both the controller and the checksynch board must agree that it is safe to close the switch before the switch will operate. In this way, if a fault develops in one of the modules, it will be caught safely by the other module.

The board monitors the incoming utility and the output of the generator. In order for the unit to parallel, the voltages, frequency, phase rotation and phase of these supplies must agree with each other (see section 2.18), for a minimum period of time, before the transfer switch is allowed to close.

The board interfaces to the transfer switch via the interposing relay logic.

There are three green LED's on the board, the one towards the rear of the board indicates that the incoming utility is within voltage and frequency tolerances. The center LED indicates that the phase rotation of the two supplies is correct (you must run the generator with utility present to get this to operate). The tolerances for Checksynch board are:

- less than $\pm 10\%$ voltage
- less than ± 0.5 Hz
- less than $\pm 15^\circ$

The front LED indicates when the two supplies are in phase or in sync. As the unit tries to parallel, or is running in manual with utility present, it will illuminate for brief periods of time as the unit gets in sync.

The board will detect "deadbus" conditions (when either of the two supplies is missing) and will allow the transfer switch to close without looking for phase synchronization.

2.23 RELAY PROTECTION SCHEME

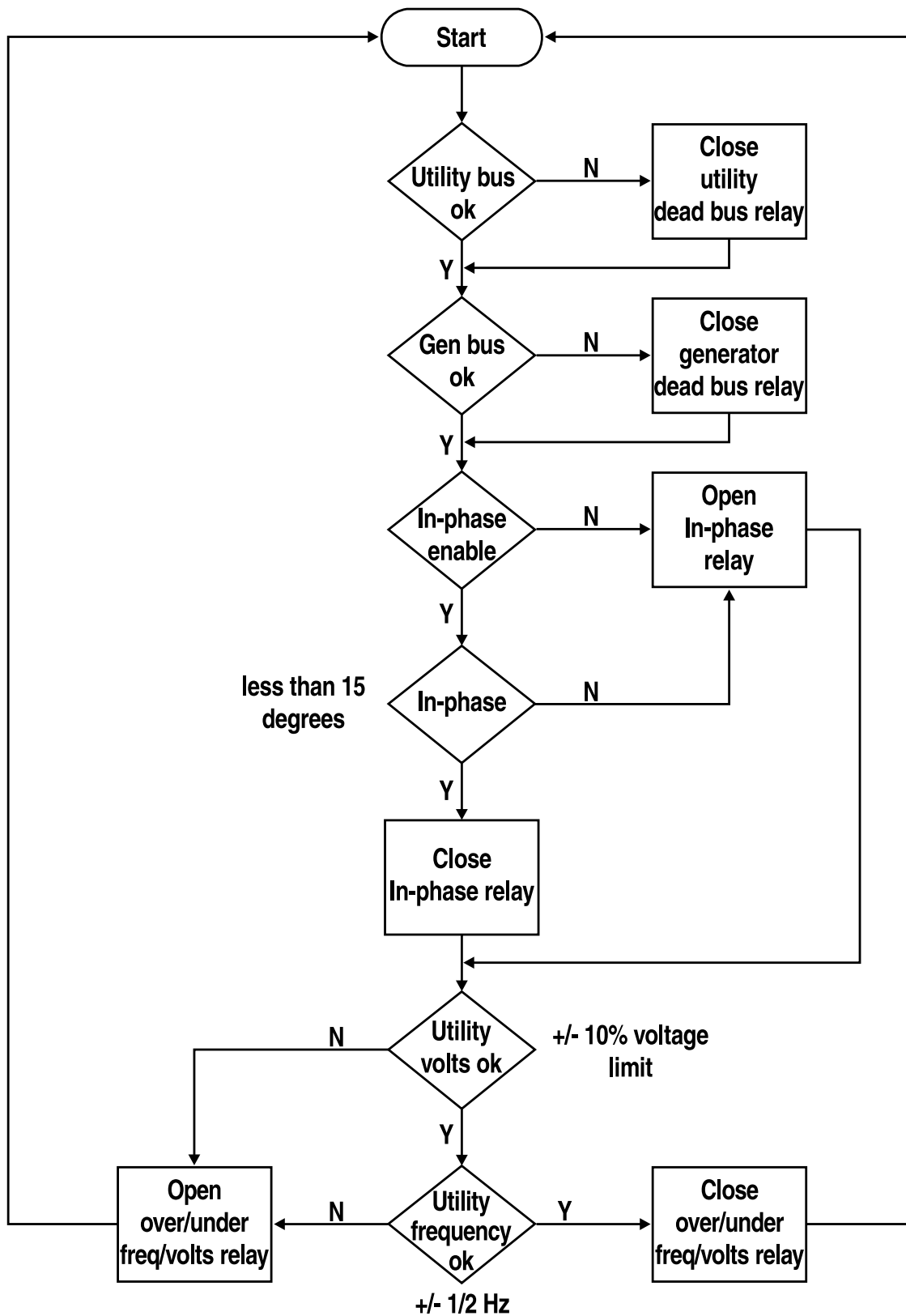

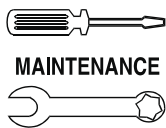

3.1 CHECKING THE ENGINE OIL LEVEL

For oil capacities, see “Specifications,” Section 1.4, Page 5. For engine oil requirements, see Section 1.6. To check the engine oil level, proceed as follows (Figures 3.1 and 3.2):

1. Remove the dipstick and wipe it dry with a clean cloth.
2. Install the dipstick fully into cap; then, remove it again. The oil level should be at the dipstick “Full” mark. If necessary, add oil to the “Full” mark only. **DO NOT FILL ABOVE THE “FULL” MARK.**
3. Install the dipstick.



⚠ Never operate the engine with the oil level below the “Add” mark on the dipstick. Doing this could damage the engine. If the oil level on the dipstick is below the “Add” mark, there may not be any reserve oil left in the reservoir. Check the reservoir oil and fill as needed per Section 3.2.2.

Figure 3.1 – Oil Dipstick and Fill

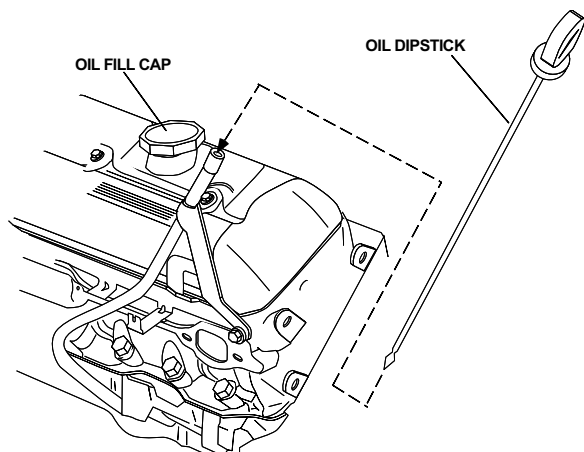

3.2 CHANGING THE ENGINE OIL AND FILTER

◆ 3.2.1 ENGINE OIL REQUIREMENTS

See Section 1.6, page 5.



⚠ Any attempt to crank or start the engine before it has been properly serviced with the required oil may result in an engine failure.

◆ 3.2.2 OIL AND FILTER CHANGE PROCEDURE

To change the oil and filter, proceed as follows:

Refer to the “Service Schedule,” (Section 3.11, Page 24) for engine oil and filter change intervals.

Drain the oil while the engine is still warm from running. This means you should warm up the engine, shut it down and drain it immediately.

The DG 50 has an extended run oil reservoir and a float valve mechanism that maintains a constant oil level in the oil pan.

The reservoir has an atmospheric vent. To avoid spillage during transit, the unit is shipped in a “semi-wet” state, with approximately 1 inch of oil in the reservoir. This amount of oil is enough to start the unit and run for several hours, but the upper reservoir needs to be filled according to the instructions below for extended maintenance operation.

A special pump kit (Part No. C8541) is available for this purpose. The kit includes a drain pump and a fill pump; one is meant for clean engine oil fill and the other for draining used engine oil out of the lower pan. To prevent cross-contamination, the fittings on the two hose assemblies are matched to the tank they are intended to drain or fill. The drain hose cannot be fitted to the reservoir and the fill hose cannot be fitted to the oil pan.

► 3.2.2.1 Draining the Engine Pan of Used Oil

1. At the recommended oil change interval, shut down the unit and connect the drain pump to the hose assembly attached to the lower pan.

NOTE:

Do not attempt drainage while the unit is operating.

2. Close the oil drain valve (Figure 3.2) and connect the pump to a 12 volt source such as the engine battery.

Figure 3.2 — Oil Drain Valve

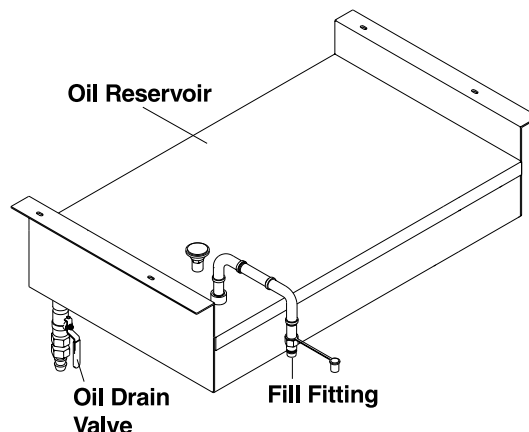

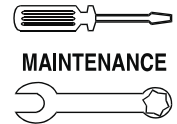

3. Check the direction of flow to ensure the oil is being drained out of the oil pan.
This pump may also be used to clean up any liquids that have collected in the spill pans lining the bottom of the unit.
4. Use oil filter wrench to turn the oil filters (Generac part number C3784, Figure 3.3) counterclockwise and remove them. Properly dispose of the old filters.

Figure 3.3 – Oil Filter and Air Cleaner

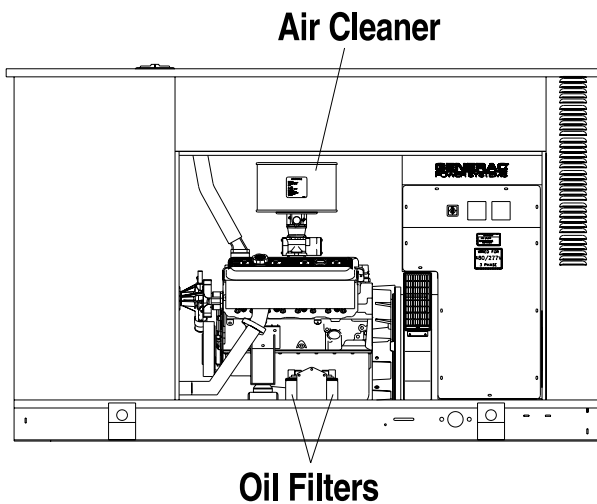

5. Apply a light coating of clean engine oil to the seal of each new oil filter. Install the filters and tighten by hand only. **DO NOT OVERTIGHTEN.**

▶ 3.2.2.2 Filling the Unit With Clean Oil

1. Remove the oil fill cap as shown in Figure 3.1 and fill the crankcase with oil as specified in Section 1.6. **DO NOT FILL ABOVE THE DIPSTICK “FULL” MARK.** Crankcase capacity is listed in Section 3.11.
2. The upper reservoir has a quick-disconnect fitting and a sight glass. Connect the hose from the fill pump to this fitting and pump fresh oil into the reservoir.
3. Monitor the sight glass carefully and fill the reservoir to the top of the sight glass. **DO NOT OVER-FILL.**
4. Open the tank valve and let the system balance to the proper level.



- ▲ After refilling the crankcase with oil, always check the oil level on the dipstick. Operating the engine with the oil level below the “Add” mark on the dipstick could damage the engine.**
5. Start the engine and check for oil leaks.
 6. Check the oil level after checking for leaks to ensure that the oil is filled to the proper level.

3.3 CHANGING THE ENGINE AIR CLEANER

To replace the engine air cleaner, (Generac part number C3197), simply remove the air cleaner cover and replace the air filter making sure it is positioned properly before reattaching the cover. See Figure 3.2.

See the “Service Schedule,” Section 3.11, Page 24, for recommended air cleaner maintenance.

3.4 SPARK PLUGS

Reset the spark plug gap or replace the spark plugs as necessary. See Section 3.11.

1. Clean the area around the base of the spark plugs to keep dirt and debris out of the engine.
2. Remove the spark plugs and check the condition. Clean the plugs by scraping using a wire brush. Do not blast the spark plugs to clean. Replace the spark plugs if worn or if reuse is questionable. See the “Service Schedule,” Section 3.11 for recommended inspection.
3. Check the spark plug gap using a wire feeler gauge. Adjust the gap to 0.035 inch (.89 mm) by carefully bending the ground electrode (Figure 3.4).

Figure 3.4 – Setting the Spark Plug Gap

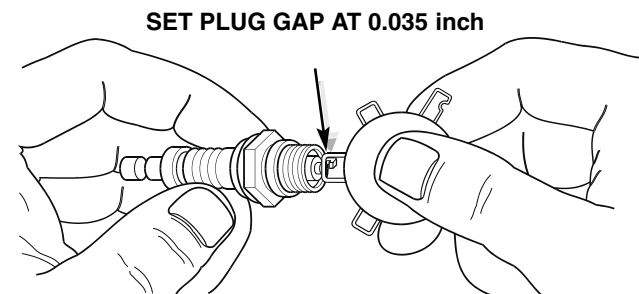

3.5 BATTERY MAINTENANCE

The battery should be inspected at intervals specified in the “Service Schedule,” Section 3.11. The following procedure should be followed for inspection:

1. Inspect the battery posts and cables for tightness and corrosion. Tighten and clean as necessary.
2. Check the battery fluid level of unsealed batteries and, if necessary, fill with **DISTILLED WATER ONLY. DO NOT USE TAP WATER IN BATTERIES. When using maintenance free batteries these procedures are not necessary.**
3. Have the state of charge and condition checked. This should be done with an automotive-type battery hydrometer or load test.

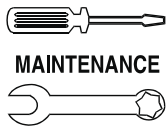

Section 3 – Maintenance

DG 50 Generator Set

⚠ DANGER ⚠

⚠ Storage batteries give off explosive hydrogen gas. This gas can form an explosive mixture around the battery for several hours after charging. The slightest spark can ignite the gas and cause an explosion. Such an explosion can shatter the battery and cause blindness or other injury. Any area that houses a storage battery must be properly ventilated. Do not allow smoking, open flame, sparks or any spark producing tools or equipment near the battery.

⚠ Battery electrolyte fluid is an extremely caustic sulfuric acid solution that can cause severe burns. Do not permit fluid to contact eyes, skin, clothing, painted surfaces, etc. Wear protective goggles, protective clothing and gloves when handling a battery. If you spill the fluid, flush the affected area immediately with clear water.

⚠ Do not use any jumper cables or booster battery to crank and start the generator engine. If the battery has completely discharged, remove it from the generator for recharging.

⚠ WARNING ⚠

⚠ Be sure the utility power supply is turned off, or sparking may occur at the battery posts as you attach the cables and cause an explosion.

NOTE:

Disconnect the cable from the negative (-) terminal first. Reconnect the negative (-) terminal last.

⚠ Be sure the Auto/Off/Manual switch is set to the OFF position before connecting the battery cables. If the switch is set to AUTO or MANUAL, the generator can crank and start as soon as the battery cables are connected.

3.6 COOLING SYSTEM

Air intake and outlet openings in the generator compartment must be open and unobstructed for continued proper operation. This includes such obstructions as high grass, weeds, brush, leaves and snow.

Without sufficient cooling and ventilating air flow, the engine/generator quickly overheats, which causes it to shut down. (See Figure 3.5 for vent locations.)

⚠ WARNING ⚠

⚠ The exhaust system of this product gets extremely hot and remains hot after shutdown. High grass, weeds, brush, leaves, etc. must remain clear of the exhaust. Such materials may ignite and burn from the heat of the exhaust system.

Figure 3.5 – Air Intake and Outlet Locations

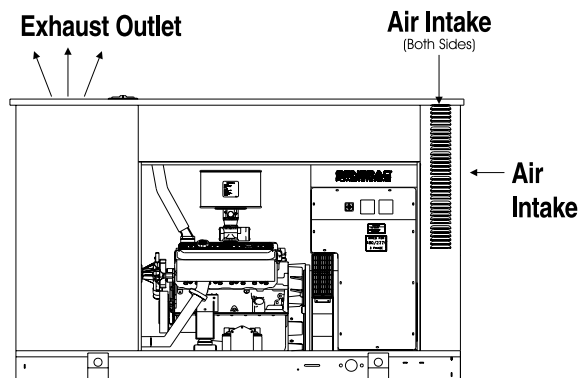

◆ 3.6.1 ENGINE HEATER

Your Generac generator comes equipped with a block heater (Figure 3.6) that is similar to the block heaters used in automotive applications.

Figure 3.6 – Engine Block Heater

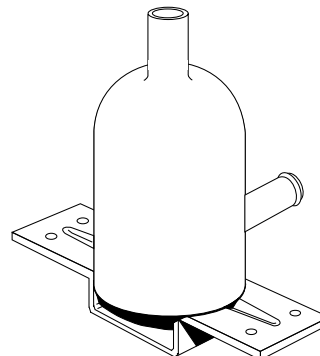

Refer to applicable wiring diagram(s) and electrical schematic(s) at the back of this manual for wiring connections.

3.7 OVERLOAD PROTECTION FOR ENGINE DC ELECTRICAL SYSTEM

Engine cranking, start-up and running are controlled by a solid-state engine controller circuit board. Battery voltage is delivered to that circuit board via a 15-amp fuse. These overcurrent protection devices will open if the circuit is overloaded.

⚠ CAUTION ⚠

⚠ If a circuit breaker opens or a fuse element melts, you should find the cause of the overload before resetting the circuit breaker or replacing the fuse.

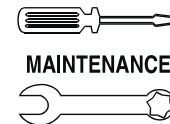

◆ 3.7.1 FUSE

The generator panel's 15-amp fuse (Figure 3.7) protects the DC control circuit against overload. The fuse is wired in series with the battery output lead to the panel. If the fuse element has melted open, you cannot crank or start the engine. You should replace the fuse using only an identical 15-amp replacement.

Figure 3.7 – Location of 15-amp Fuse

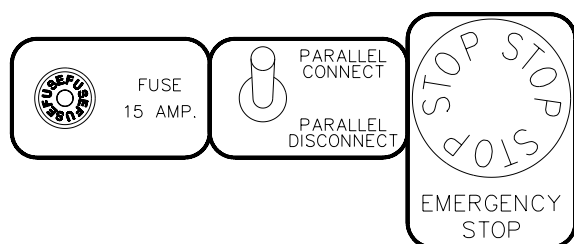

3.8 ENGINE COOLANT

- Add the recommended coolant mixture as necessary. See Section 1.4.2 on Page 5.
- Coolant should be at the bottom of the radiator filler neck. If the coolant level is low, inspect the gasket in the radiator pressure cap. Replace the cap, if necessary. To have the pressure cap tested, contact a Generac Authorized Dealer.

3.9 MISCELLANEOUS MAINTENANCE

◆ 3.9.1 CLEANING THE GENERATOR

Keep your generator as clean and as dry as possible. Dirt and moisture that accumulate on internal generator windings have an adverse effect on insulation resistance.

Periodically, clean the generator's exterior surfaces. A soft brush may be used to loosen caked on dirt. You can use a vacuum system or dry, low pressure air to remove any accumulations of dirt. The generator is housed inside an all-weather enclosure; clean the enclosure with a soft, damp cloth or sponge and water.

Although the enclosure will protect against rain entering the compartment, it is not designed to keep out high pressure water jets. Avoid the use of high pressure cleaning equipment.

Once each year, have the generator cleaned and inspected by a Generac Authorized Dealer. Service technicians will use dry, low pressure air to clean internal windings. Parts inside the control console should be cleaned and inspected at this time as well.

Finally, have the insulation resistance of stator and rotor windings checked. If insulation resistances are excessively low, the generator may require drying.

◆ 3.9.2 CLEANING THE RADIATOR

As indicated in the Service Schedule (Section 3.11) the radiator fins require periodic cleaning. Fouling of these fin openings will dramatically reduce the overall cooling capacity of the radiator and lead to frequent overheating. The fins are fragile and should be cleaned carefully. Damage to or bending of these fins will also reduce cooling capacity. Clean the fins only using a soft brush and a vacuum. A final cleaning using low pressure air directed at the fan side ONLY may help remove embedded material.

◆ 3.9.3 RODENT PROTECTION

The intrusion of rodents into the generator set can cause a wide range of problems, from failure of the unit to start, to personal injury and, in extreme circumstances, short circuit or fire. Although the unit was designed to limit this problem, further precautions can be taken by the owner to help minimize both the chance of rodent entry and the extent of any damage. Inside the generator set, the chance of rodent entry into the control panel is greatly reduced by the inclusion of adjustable wire connectors. Check that the wire connector screws are tight, thus closing off any gap between the access holes and the wires.

3.10 OUT OF SERVICE PROCEDURE

◆ 3.10.1 REMOVAL FROM SERVICE

If you cannot exercise the generator every seven days, and it is to be out of service longer than 90 days, prepare the generator for storage as follows:

1. Start the engine and let it warm up.
2. Close the fuel shutoff valve in the fuel supply line and allow the unit to shut down.
3. Once the unit has shut down, it will signal a fault on the control panel.
4. Set the Auto/Off/Manual switch to OFF and turn off the utility power to the transfer switch.
5. While the engine is still warm from running, drain the oil completely and refill the crankcase with required oil as described in Section 3.2.2.
6. Attach a tag to the engine indicating the viscosity and classification of the oil in the crankcase.
7. Remove the spark plug(s) and spray fogging agent into the spark plug(s) threaded openings. Reinstall and tighten the spark plug(s).
8. Remove the battery and store it in a cool, dry room on a wooden board. Never store the battery on any concrete or earthen floor.
9. Clean and wipe the entire generator.

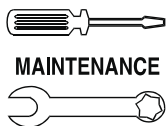

MAINTENANCE

Section 3 – Maintenance

DG 50 Generator Set

3.11 SERVICE SCHEDULE

ATTENTION: It is recommended that all service work be performed by your nearest Generac Authorized Dealer.

EVERY 1000 HOURS	PROCEDURE	QUANTITY	VISUALLY CHECK
	Change Oil (Engine Crankcase)	5 Quarts	Coolant Level
	Fill Oil Tank (Reserve Tank)	10 Gallons	Fan Belt
	Change Oil Filters (Part Number C3784)	2	Serpentine Belt
	Grease DC Charge Alternator	1	Air Filter
	Grease Fan Drive Shaft Bearing	1	Radiator Hoses & Clamps
		1	Spark Plugs & Wires
	Clean Radiator Fins		Radiator Fin Fouling
	Check exhaust manifold bolts. Torque to specifications listed in exploded view as necessary.		
	Check batteries per Sections 1.7 and 3.5		
EVERY 2000 HOURS	Same Items as 1000 Hour Maintenance		Same as 1000 Hour Maint.
	Change Spark Plugs (Part Number 59503)	8	DC Alternator Bearings
	Change Air Filter (Part Number C3197)	1	Upper & Lower Fan Drive Bearings
	Change Fan Belts (Part Number C6549)	2	Serpentine Belt Idler Bearing
	Change Serpentine Belt (Part Number C5482)	1	
EVERY 10000 HOURS	Change Cylinder Heads (Remanufactured)	2	Fan Drive Shaft Bearings
	Change Head Gasket	2	Water Pump Bearing
	Change Intake Manifold Gasket	2	Serpentine Belt Tensioner & Idler
	Change Valve Cover Gasket	2	
	Change Distributor Gasket (Part Number C4389)	1	
	Change Distributor Cap & Rotor	1 Each	
	Change Spark Plug Wires (Part Number C4701)	9	



4.1 TROUBLESHOOTING GUIDE

PROBLEM	CAUSE	CORRECTION
The engine will not crank.	<ol style="list-style-type: none"> 1. Fuse blown 2. Loose, corroded or defective battery cables 3. Defective starter contactor 4. Defective starter motor 5. Dead Battery 	<ol style="list-style-type: none"> 1. Replace fuse. 2. Tighten, clean or replace as necessary. 3. * 4. * 5. Charge or replace battery.
The engine cranks but will not start.	<ol style="list-style-type: none"> 1. Out of fuel 2. Defective fuel solenoid (FS) 3. Open #14 wire from engine control board 4. Defective spark plug(s) 5. Dirty/Blocked air filter 	<ol style="list-style-type: none"> 1. Replenish fuel. 2. * 3. * 4. Clean, re-gap or replace plug(s). 5. Clean or replace as required.
The engine starts hard and runs rough.	<ol style="list-style-type: none"> 1. Clogged or damaged air cleaner 2. Defective spark plug(s) 	<ol style="list-style-type: none"> 1. Check, clean or replace air cleaner. 2. Clean, re-gap or replace plug(s).
The engine starts, but then shuts down.	<ol style="list-style-type: none"> 1. Engine oil level low 2. Defective low oil pressure switch 3. Defective high temperature switch 4. Defective control board 5. Low coolant level 	<ol style="list-style-type: none"> 1. Check oil and add oil as needed. 2. * 3. * 4. * 5. Check coolant level, repair leaks and refill.
The Auto/Off/Manual switch is set to OFF, but the engine continues to run.	<ol style="list-style-type: none"> 1. Defective switch 2. Defective control board 	<ol style="list-style-type: none"> 1. * 2. *
There is no AC output from the generator.	<ol style="list-style-type: none"> 1. Generator main line circuit breaker open 2. Generator internal failure 	<ol style="list-style-type: none"> 1. Reset circuit breaker to ON (or closed). 2. *
There is no transfer to standby after utility source failure.	<ol style="list-style-type: none"> 1. Generator main line circuit breaker open 2. Defective transfer switch coil 3. Defective transfer relay 4. Transfer relay circuit open 5. Defective control logic board 	<ol style="list-style-type: none"> 1. Reset circuit breaker to ON (or closed). 2. * 3. * 4. * 5. *

***Contact your nearest Generac Authorized Dealer for assistance.**

STANDARD CONFIGURATIONS

GROUP	PARAMETER	DEFAULT VALUE	CHANGE TO:
Alarms	Fuel Level Alarm On/Off	Off	
	Battery High	15	
	Battery Low	10	
	Underfrequency	50	
	Overfrequency	70	
	Low Fuel Shutdown	0	
	Fuel Level Low Warning	5	
	Fuel Level High Setpoint	80	
	Undervoltage	350	150 for 208V*
	Overvoltage	530	270 for 208V*
	Overspeed	2300	
	Underspeed	1500	
	Coolant Low Temperature Shutdown Alarm	0	
	Coolant High Temperature Shutdown Alarm	245	
	Coolant High Temperature Warning	225	
	Oil Temperature shutdown Alarm	235	
	Oil Temperature Warning	225	
	Oil Pressure Shutdown Alarm	15	
Oil Pressure Warning	25		
Engine	Port Setting	Modem	
	Preheat	No	
	Exercise	No Transfer	
	Flywheel Teeth	168	
	Start Disengage Speed	500	
	Start Attempts	3	
	Cool Down	0	1 min.*
	Warmup	0	
	Alarm Hold Off	8	
	Start Pause	5	
	Start Timer	4	
	Preheat Timer	0	
AVR	Generator Model Number	DG 50	
	Power Source Select	On Screen	
	Generator Voltage Scaling	0.970	
	Utility Voltage Scaling	0.960	
	Power Factor	90	
	Power	50 kW	As Required
	Governor P Gain	20	
	Governor I Gain	50	150
	Governor D Gain	70	100
	AVR Droop	0	
	Droop Select	1	
	Slope	1	
	Corner Frequency	57	
	AVR Stability	35	
	AVR Gain	40	10 for 208V*
	Frequency	60	
	Voltage	480	480/208*

Appendix 2 – F Panel Operations Display Map

DG 50 Generator Set

OPERATION

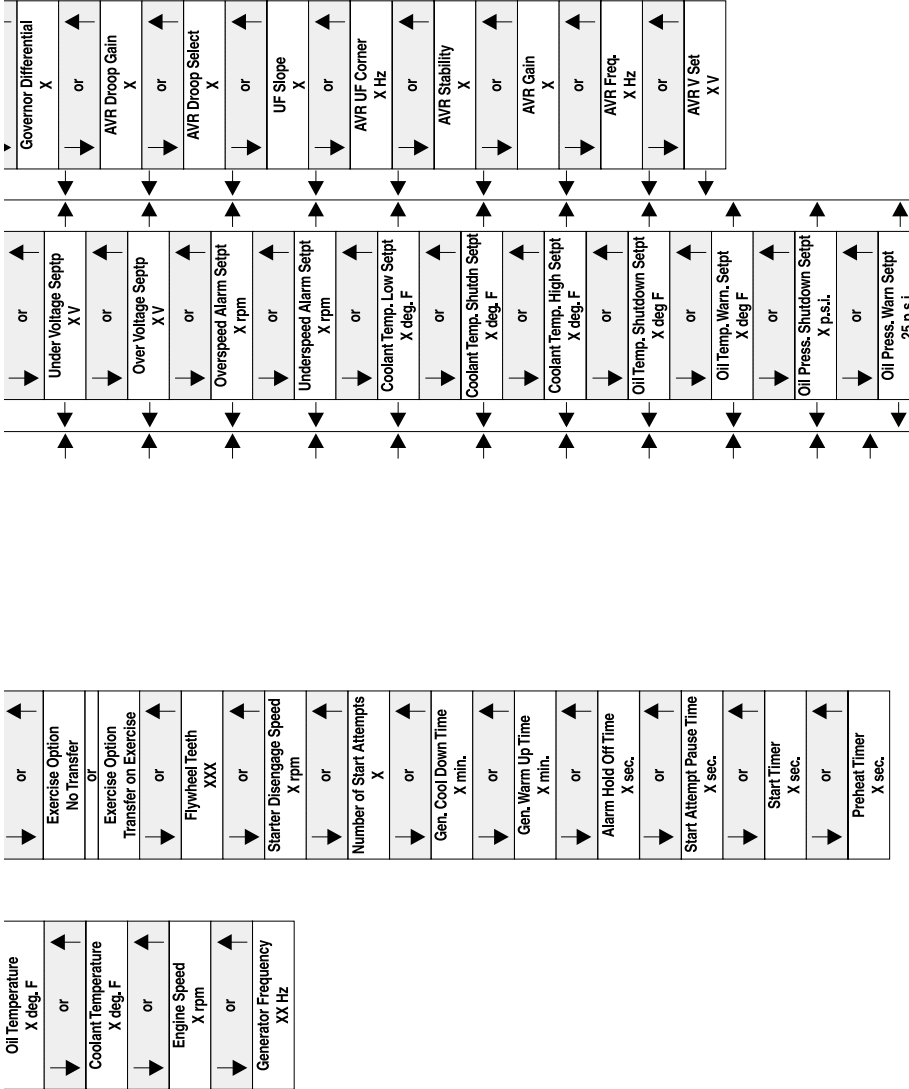
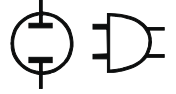

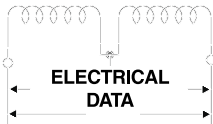

Section 6 – Electrical Data

DG 50 Generator Set

Wiring Diagram (Control Panel) – Drawing No. C5169-A

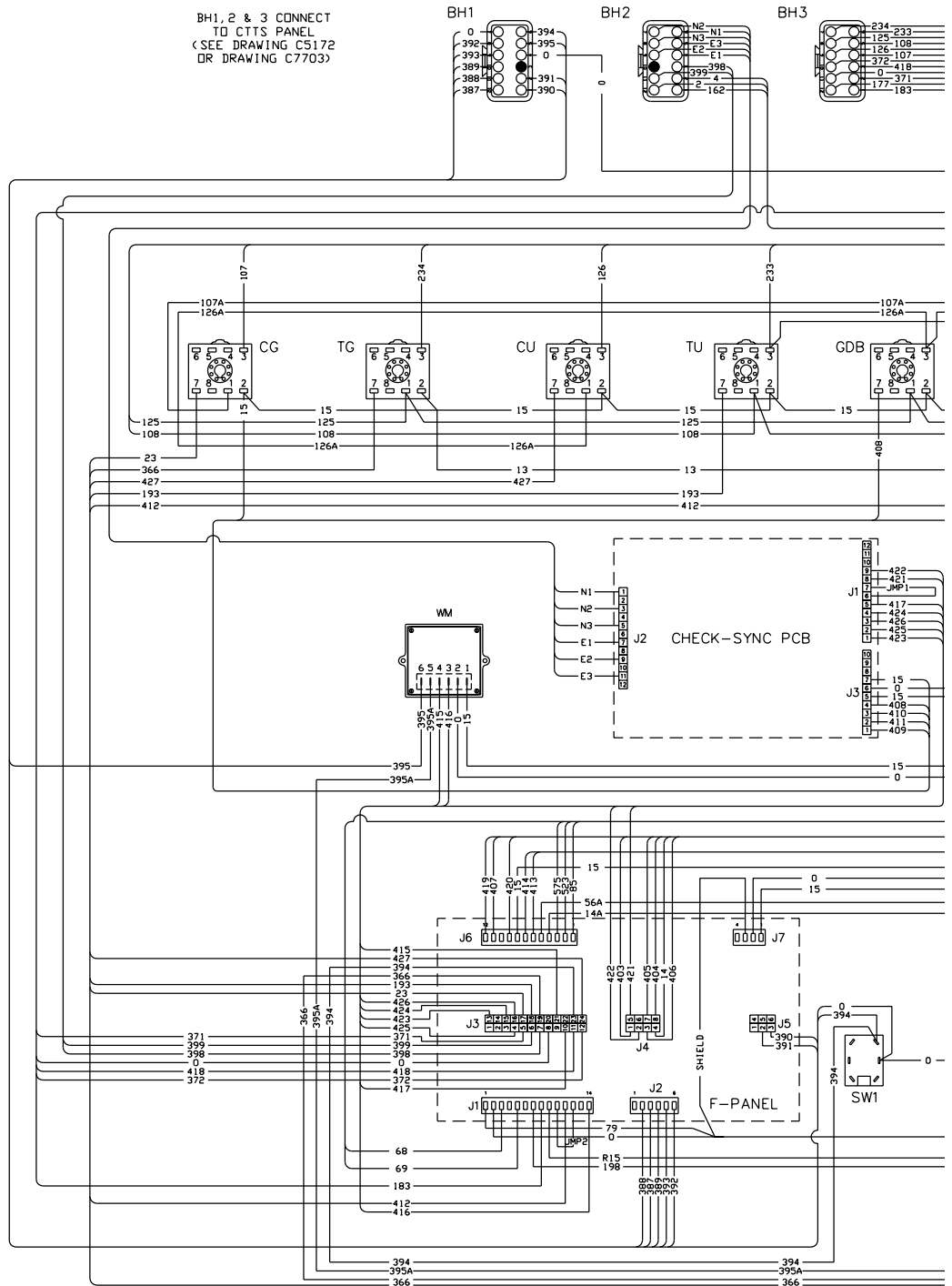

Section 6 – Electrical Data

DG 50 Generator Set Wiring Diagram (Control Panel) – Drawing No. C5169-A

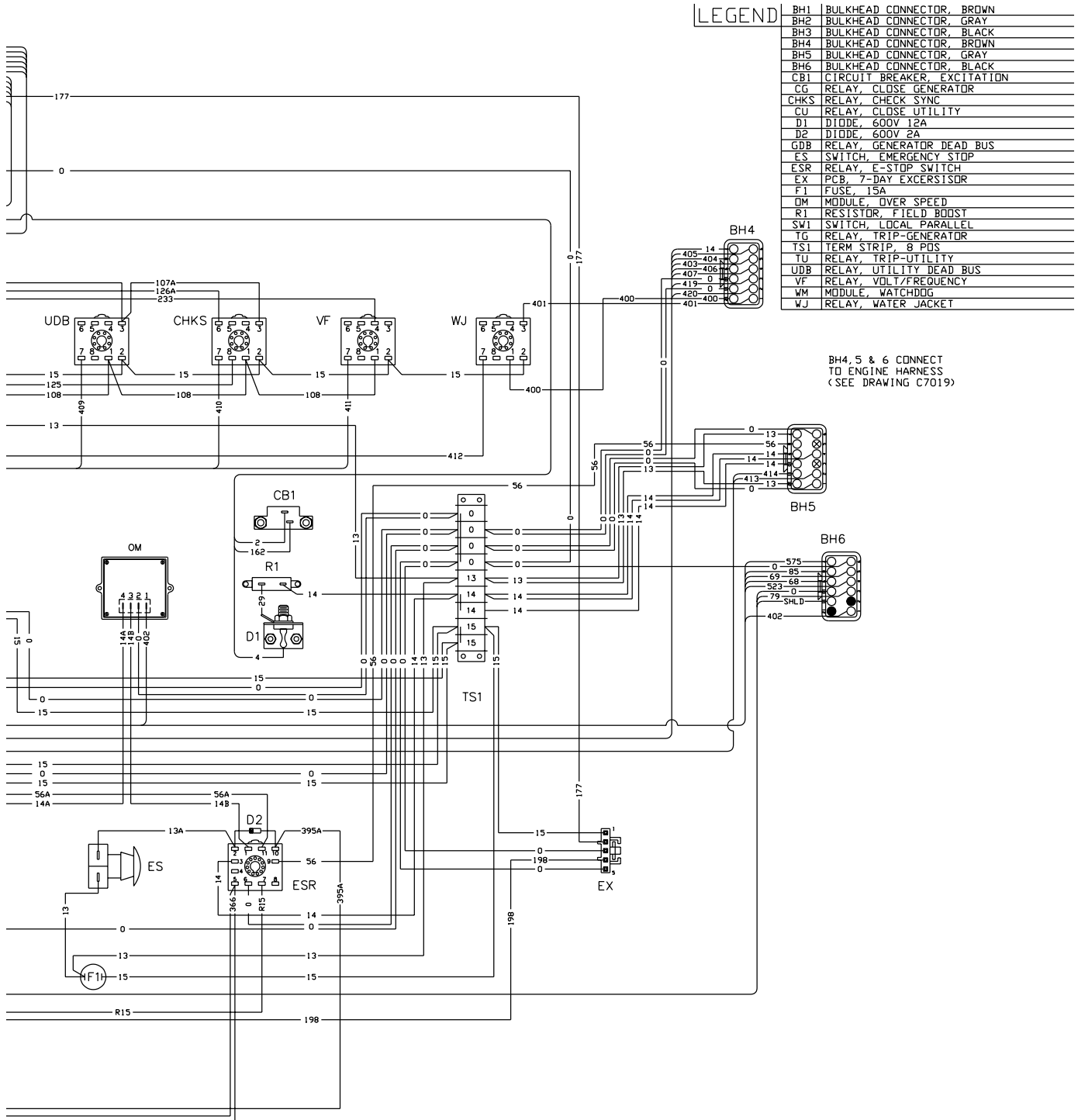
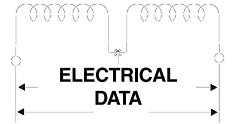

LEGEND	
BH1	BULKHEAD CONNECTOR, BROWN
BH2	BULKHEAD CONNECTOR, GRAY
BH3	BULKHEAD CONNECTOR, BLACK
BH4	BULKHEAD CONNECTOR, BROWN
BH5	BULKHEAD CONNECTOR, GRAY
BH6	BULKHEAD CONNECTOR, BLACK
CB1	CIRCUIT BREAKER, EXCITATION
CG	RELAY, CLOSE GENERATOR
CHKS	RELAY, CHECK SYNC
CU	RELAY, CLOSE UTILITY
D1	DIODE, 600V 12A
D2	DIODE, 600V 2A
GDB	RELAY, GENERATOR DEAD BUS
ES	SWITCH, EMERGENCY STOP
ESR	RELAY, E-STOP SWITCH
EX	PCB, 7-DAY EXERCISOR
F1	FUSE, 15A
OM	MODULE, OVER SPEED
R1	RESISTOR, FIELD BOOST
SW1	SWITCH, LOCAL PARALLEL
TG	RELAY, TRIP-GENERATOR
TS1	TERM STRIP, 8 POS
TU	RELAY, TRIP-UTILITY
UDB	RELAY, UTILITY DEAD BUS
VF	RELAY, VOLT/FREQUENCY
WM	MODULE, WATCHDOG
WJ	RELAY, WATER JACKET

BH4, 5 & 6 CONNECT
TO ENGINE HARNESS
(SEE DRAWING C7019)

Section 6 – Electrical Data

DG 50 Generator Set Wiring Diagram (120/208V Connection Box) – Drawing No. C7703

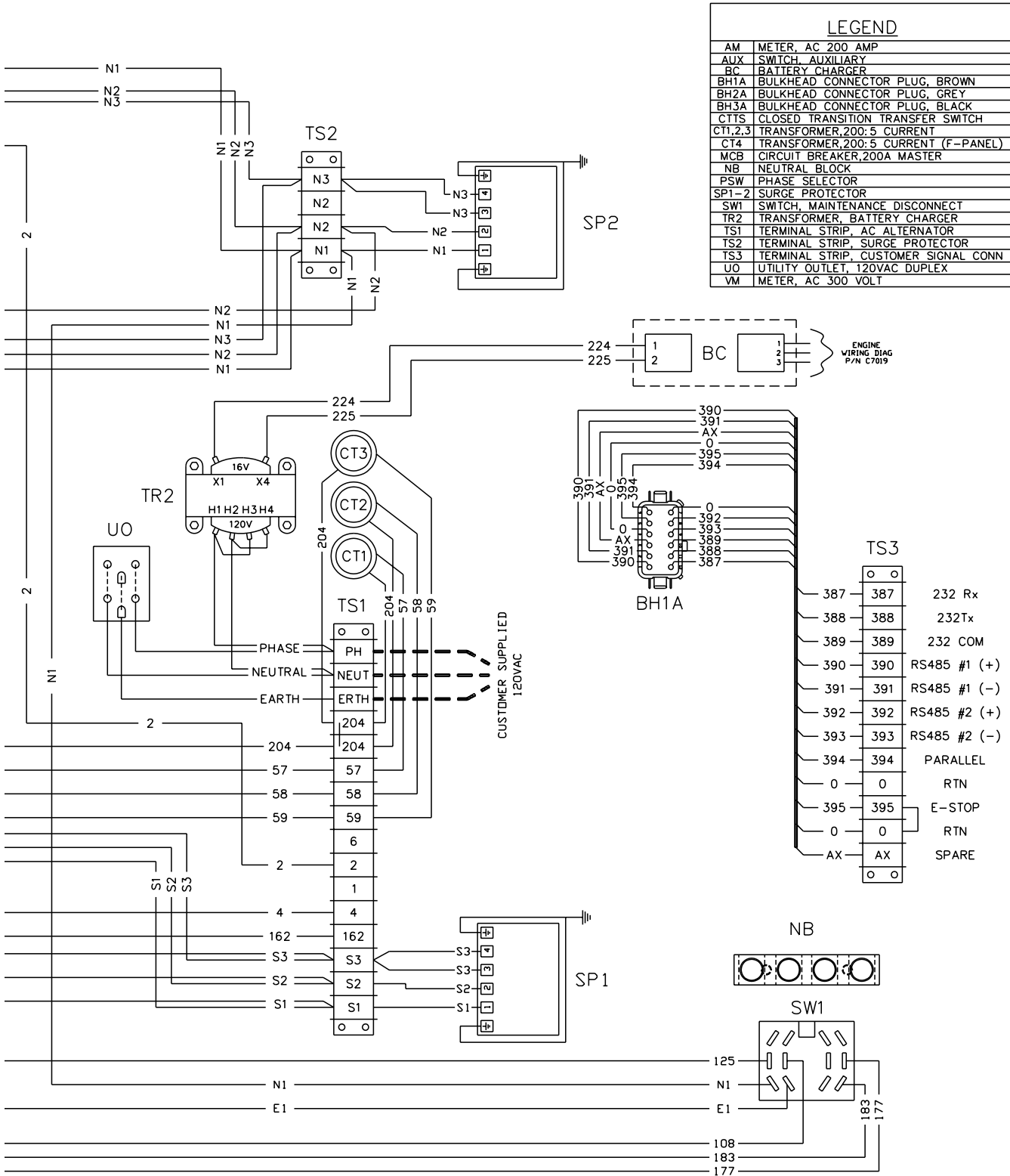
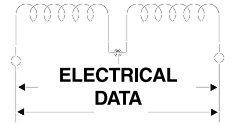

LEGEND	
AM	METER, AC 200 AMP
AUX	SWITCH, AUXILIARY
BC	BATTERY CHARGER
BH1A	BULKHEAD CONNECTOR PLUG, BROWN
BH2A	BULKHEAD CONNECTOR PLUG, GREY
BH3A	BULKHEAD CONNECTOR PLUG, BLACK
CTTS	CLOSED TRANSITION TRANSFER SWITCH
CT1,2,3	TRANSFORMER, 200:5 CURRENT
CT4	TRANSFORMER, 200:5 CURRENT (F-PANEL)
MCB	CIRCUIT BREAKER, 200A MASTER
NB	NEUTRAL BLOCK
PSW	PHASE SELECTOR
SP1-2	SURGE PROTECTOR
SW1	SWITCH, MAINTENANCE DISCONNECT
TR2	TRANSFORMER, BATTERY CHARGER
TS1	TERMINAL STRIP, AC ALTERNATOR
TS2	TERMINAL STRIP, SURGE PROTECTOR
TS3	TERMINAL STRIP, CUSTOMER SIGNAL CONN
UO	UTILITY OUTLET, 120VAC DUPLEX
VM	METER, AC 300 VOLT

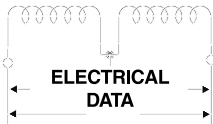

Section 6 – Electrical Data

DG 50 Generator Set

Wiring Diagram (480/277V Connection Box) – Drawing No. C5172

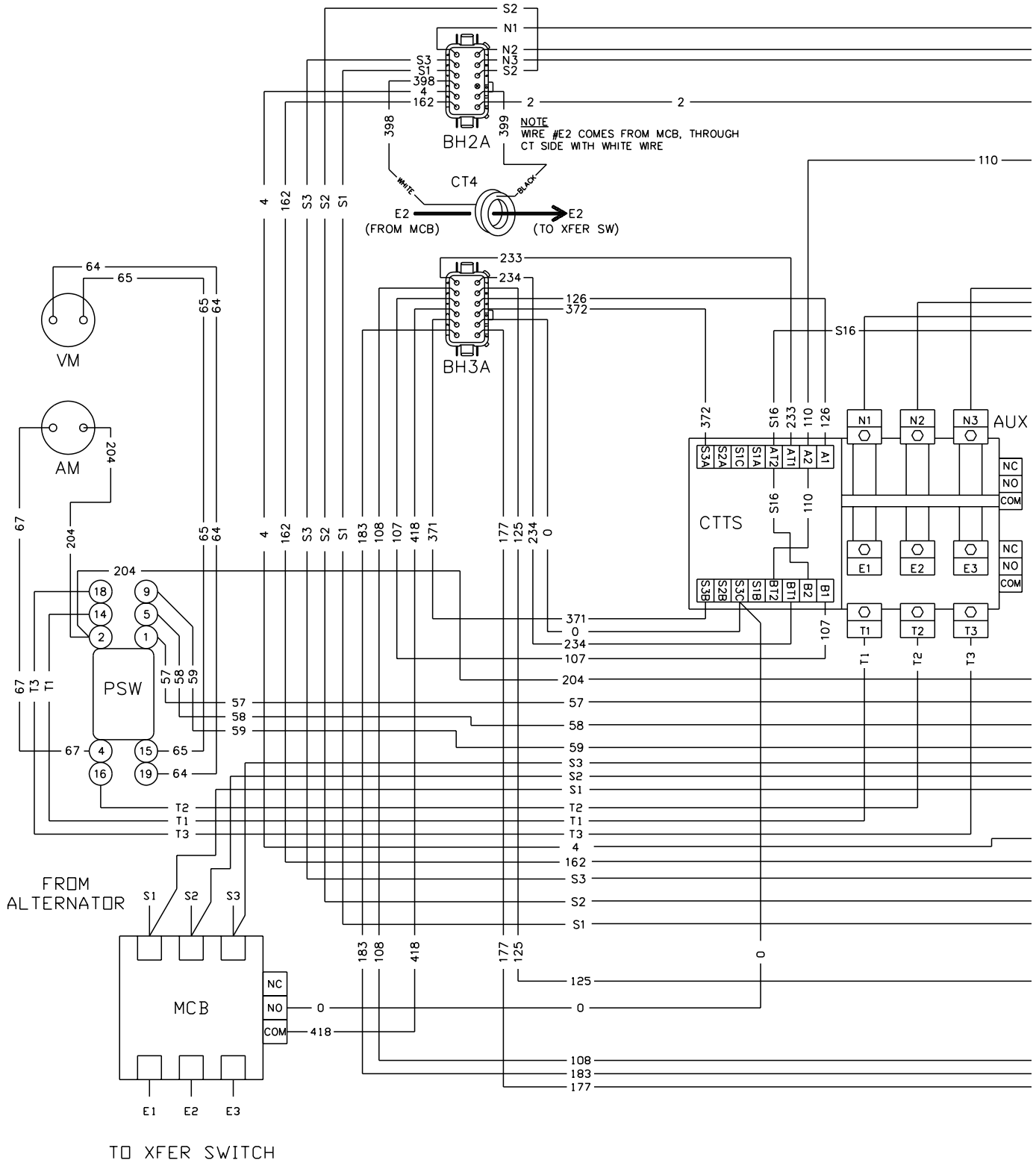

Section 6 – Electrical Data

DG 50 Generator Set
Wiring Diagram (480/277V Connection Box) – Drawing No. C5172

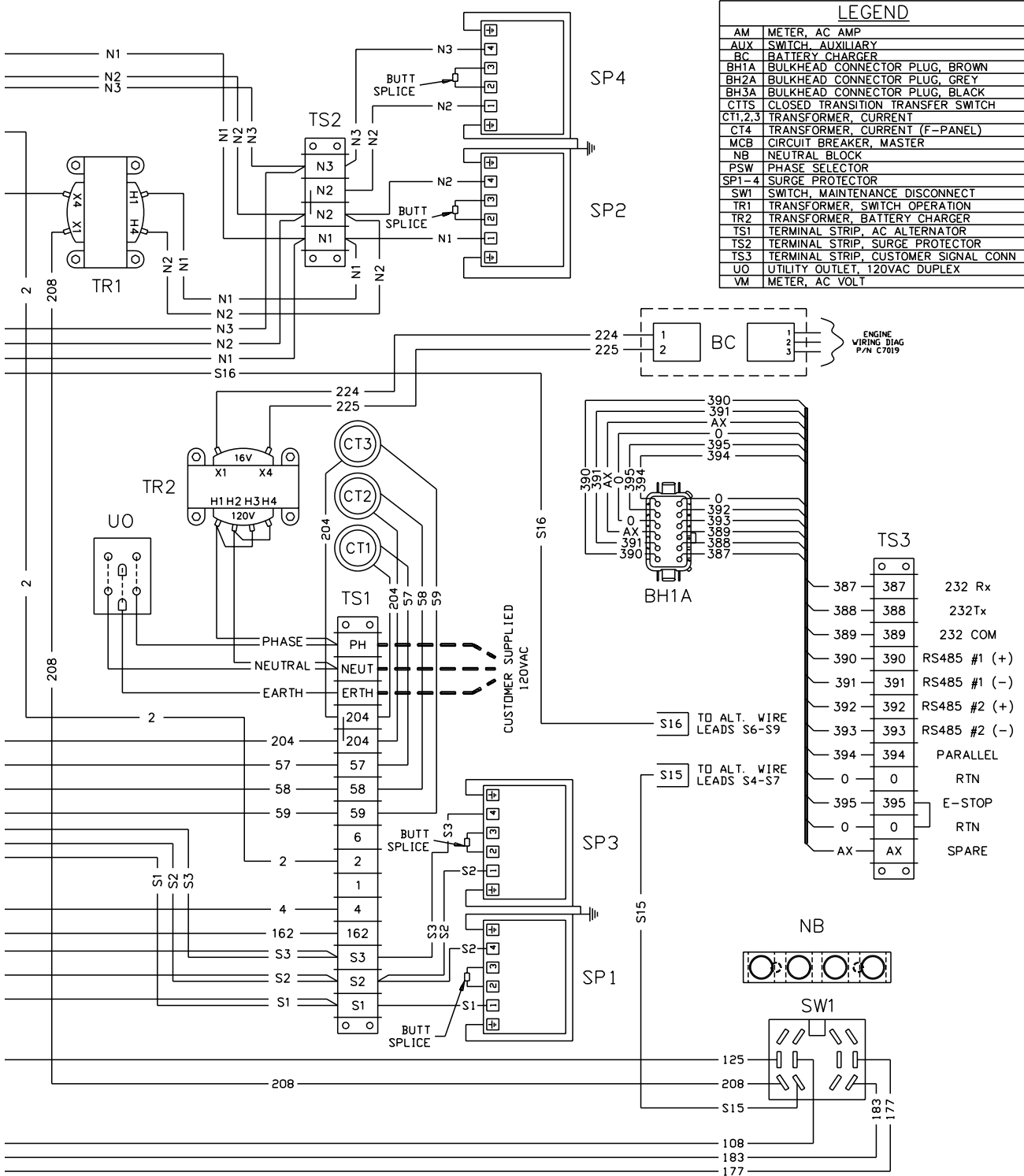
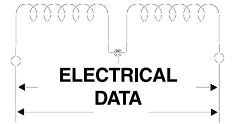

LEGEND	
AM	METER, AC AMP
AUX	SWITCH, AUXILIARY
BC	BATTERY CHARGER
BH1A	BULKHEAD CONNECTOR PLUG, BROWN
BH2A	BULKHEAD CONNECTOR PLUG, GREY
BH3A	BULKHEAD CONNECTOR PLUG, BLACK
CTTS	CLOSED TRANSITION TRANSFER SWITCH
CT1,2,3	TRANSFORMER, CURRENT
CT4	TRANSFORMER, CURRENT (F-PANEL)
MCB	CIRCUIT BREAKER, MASTER
NB	NEUTRAL BLOCK
PSW	PHASE SELECTOR
SP1-4	SURGE PROTECTOR
SW1	SWITCH, MAINTENANCE DISCONNECT
TR1	TRANSFORMER, SWITCH OPERATION
TR2	TRANSFORMER, BATTERY CHARGER
TS1	TERMINAL STRIP, AC ALTERNATOR
TS2	TERMINAL STRIP, SURGE PROTECTOR
TS3	TERMINAL STRIP, CUSTOMER SIGNAL CONN
UO	UTILITY OUTLET, 120VAC DUPLEX
VM	METER, AC VOLT

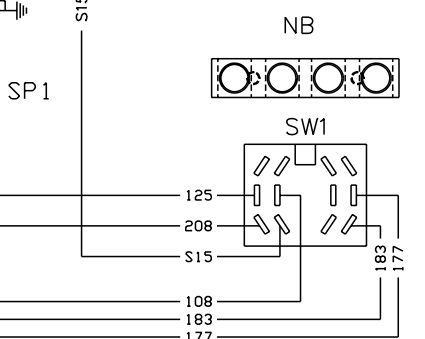
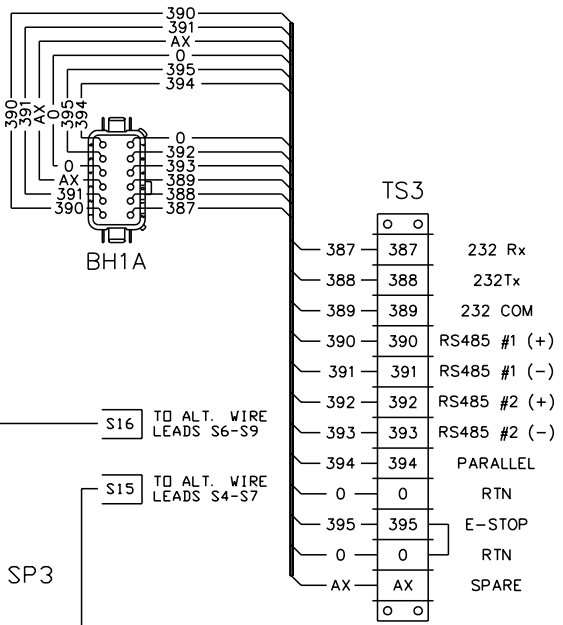
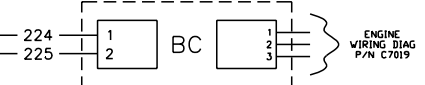

Section 7 – Exploded Views and Parts Lists

DG 50 Generator Set F Panel Relay Board Assembly – Drawing No. C5798-J

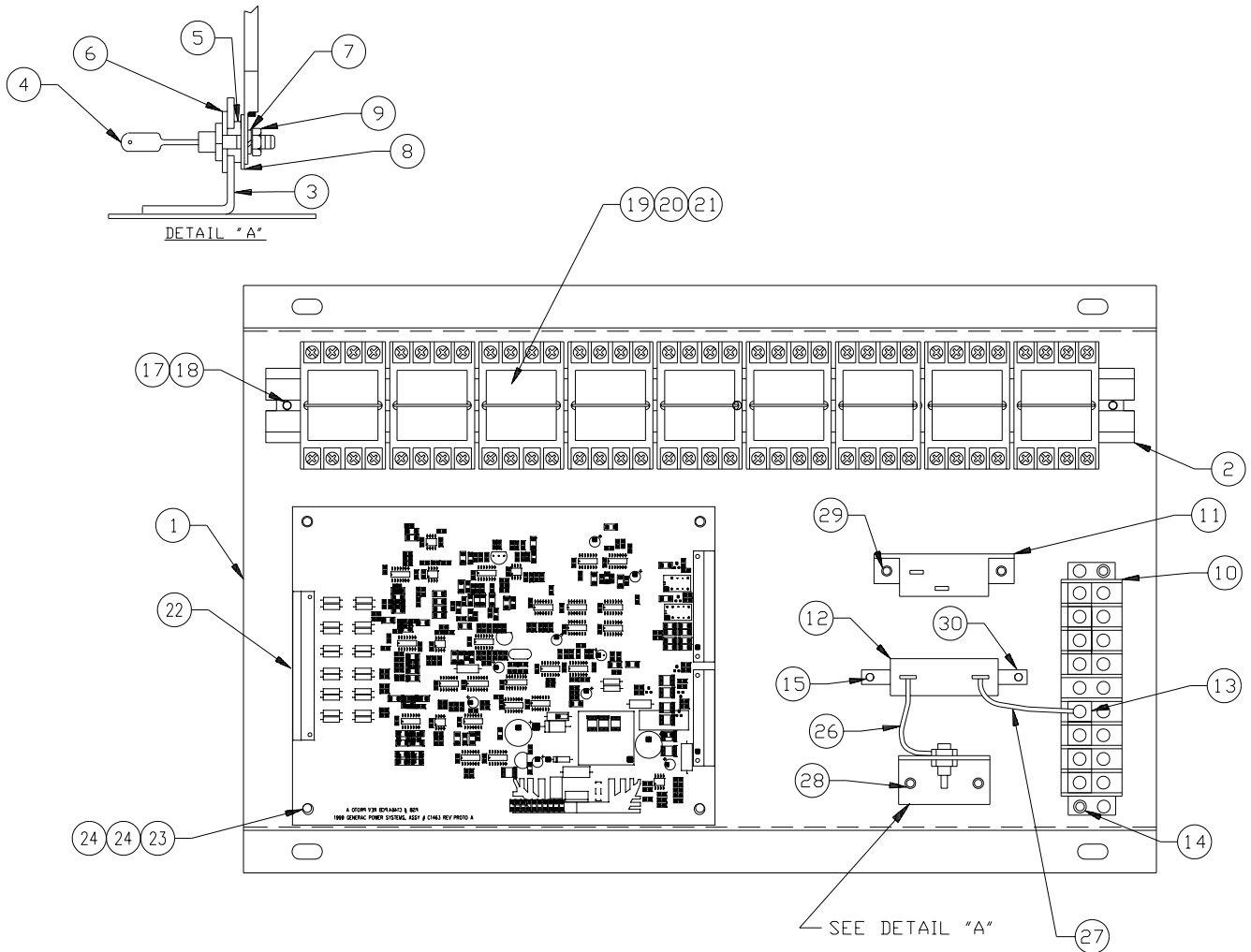
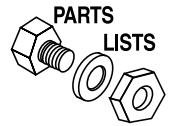

ITEM	PART NO.	QTY.	DESCRIPTION	ITEM	PART NO.	QTY.	DESCRIPTION
1	C5797	1	RELAY SUBPLATE F-PNL	17	22264	2	WASHER LOCK M4
2	C5846	1	RAIL DIN 410MM	18	C3990	2	SCREW TAPTITE PH M4-0.7 X 10 ZYC
3	55444	1	HEAT SINK 13.3L	19	C3211E	9	RELAY PNL 12VDC DPDT 8PIN
4	49939	1	RECTIFIER MSC 12A 600V 1N1206R	20	C3211G	REF	RELAY SOCKET
5	30468	1	WASHER STEP NYLON .20	21	C3211H	8	SPRING RETAINING RELAY
6	70370	1	WASHER MICA .203	22	C1463	1	RELAY PRTCTR 480V 30.1K
7	23762	1	WASHER SHAKEPROOF EXT #10 STL	23	64525	4	STANDOFF HEX 3/4
8	23897	1	WASHER FLAT #10 ZINC	24	64526	8	SCREW TAP HWH #6-25 X 3/8 Z
9	22158	1	NUT HEX #10-32 STEEL	25	C5171	1	HARNESS 50KW UTIL F-PNL C-PNL
10	61520	REF	BLOCK TERM 20A 9 X 6 X 1100V	26	199-53621	1	ASSY GROUND WIRE #29 D1-R1
11	48476	1	CIRCT BRK 4.5 X 1 AUT30KW CNT45K	27	202-53621	1	ASSY GROUND WIRE #14 TS-R1
12	57405	1	RESIST MISC 25R X 25W	28	45764	2	SCREW TAPTITE M4 X 8 BP
13	46669	REF	BLOCK TERM JUMPER FOR S141	29	C2428	2	SCREW TAPTITE PH #6-32 X 1/2 ZYC
14	A1661	2	RIVET POP .156 X .160-.164/#20	30	64733	2	RESISTOR MNTNG BRACKET FOR 25W
15	36261	2	RIVET POP .125 X .129-.133/#30				



Section 7 – Exploded Views and Parts Lists

DG 50 Generator Set
F Panel Box Assembly – Drawing No. C5946-E

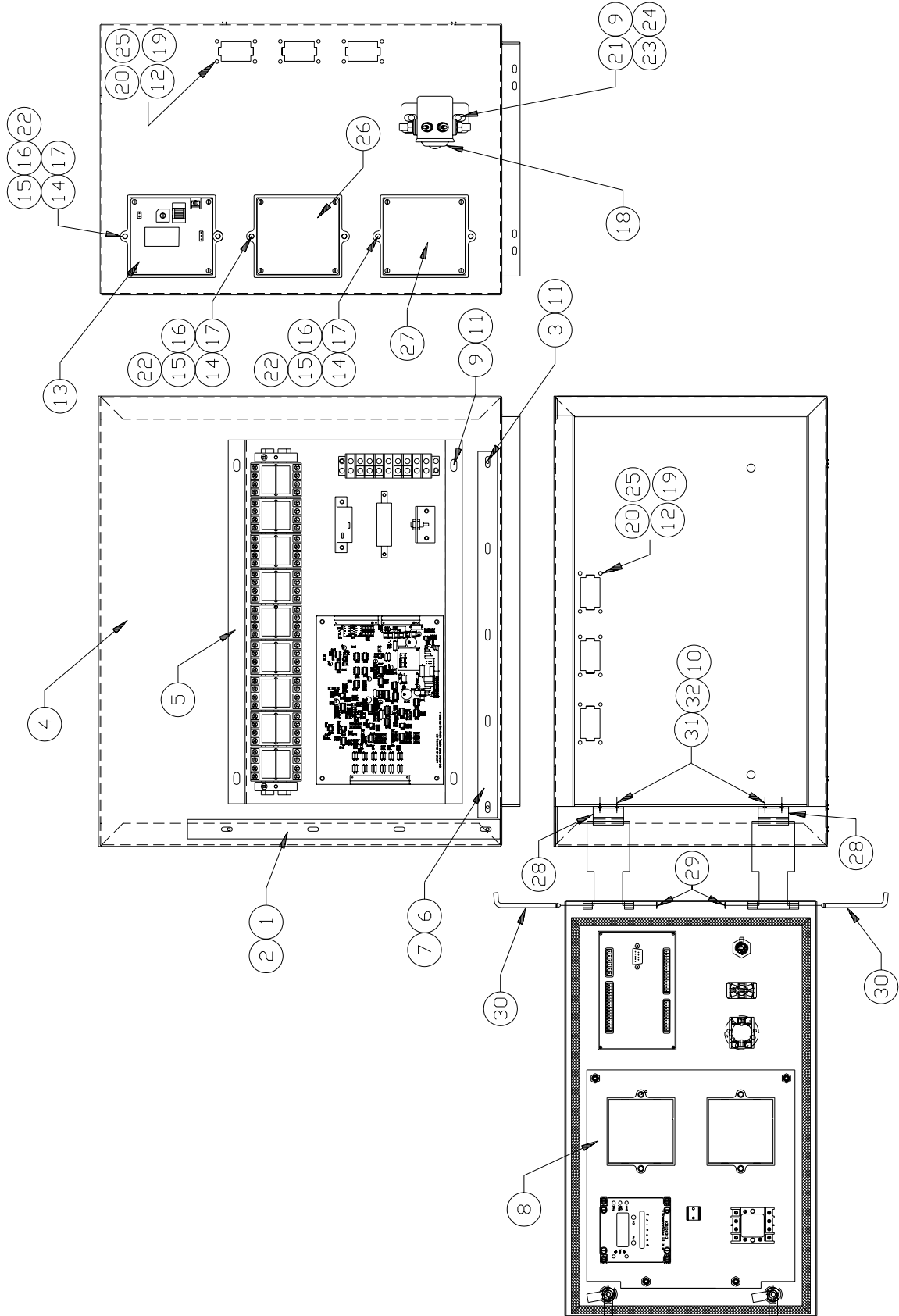

Section 7 – Exploded Views and Parts Lists

DG 50 Generator Set F Panel Box Assembly – Drawing No. C5946-E

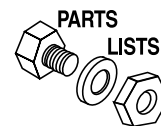

ITEM	PART NO.	QTY.	DESCRIPTION
1	C3988	1	BASE WIRE DUCT 1
2	C3988A	1	COVER WIRE DUCT 1
3	C3990	4	SCREW TAPTITE PH M4-0.7X10 ZYC
4	C5794	1	WELDMENT,C-PNL TOP
5	C5798	1	ASSY RELAY BOARD TO F-PANEL
6	C5925	1	DUCT WIRE F-PNL
7	C5925A	1	DUCT WIRE COVER F-PNL
8	C6032	1	ASSY DOOR F-PNL
9	22097	6	WASHER LOCK M6-1/4
10	22264	8	WASHER LOCK M4
11	45756	4	SCREW TAPTITE M6X10 YEL CHR
12	C5141	6	GASKET CONN BLKHD
13	A1801	1	ASSY BATTERY CHARGER ENGINE
14	29187	6	SPACER .19 X .31 X .50 STL/ZNC
15	52762	1	SCREW HHC M5-0.8 X 45 G8.8
16	51713	12	WASHER FLAT M5
17	49226	6	WASHER LOCK M5
18	56739	1	RELAY SOLENOID 12VDC PNL MNT
19	22188	24	NUT HEX #6-32 STEEL
20	22155	24	WASHER LOCK #6
21	22473	2	WASHER FLAT 1/4 ZINC
22	51716	6	NUT HEX M5-0.8 G8 YEL CHR
23	49813	2	NUT HEX M6 -1.0 G8 YEL CHR
24	49815	2	SCREW HHC M5-0.8 X 16 G8.8
25	36902	24	SCREW PPHM #6-32 X 1/2
26	C6947	1	ASSY GOV ACT MOD
27	C2846	1	MODULE POWER AVR F-PNL
28	C5719	2	HINGE FASTENED HALF
29	C5721	2	RING SNAP HINGE
30	C5722	2	PIN HINGE
31	43180	4	WASHER FLAT M4
32	49819	4	SCREW HHC M4-0.7 X 6 G8.8

Section 7 – Exploded Views and Parts Lists

**DG 50 Generator Set
F Panel Door Assembly – Drawing No. C6032-G**

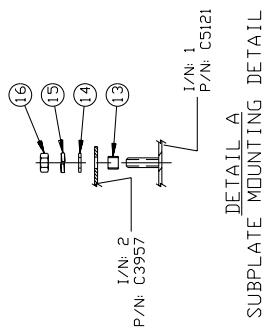
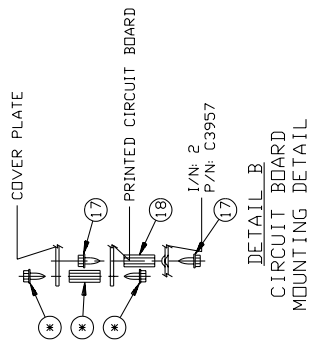

* = PARTS INCLUDED IN CIRCUIT BOARD SUBASSEMBLIES

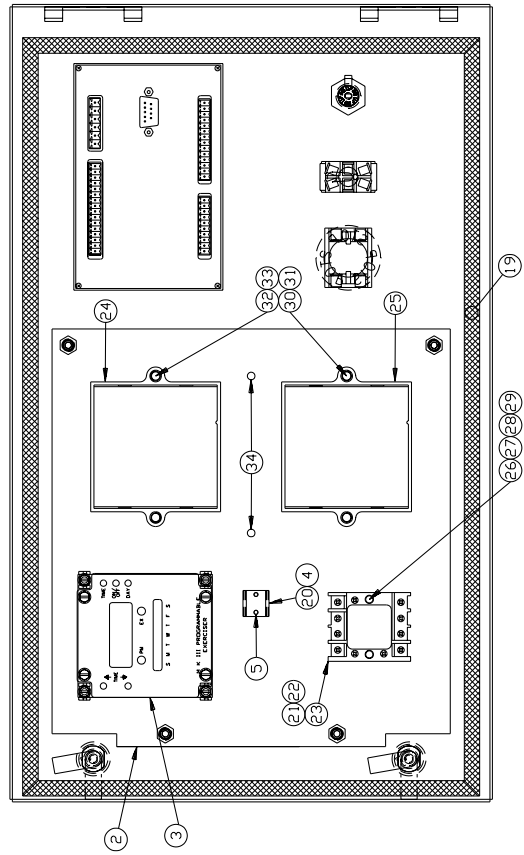
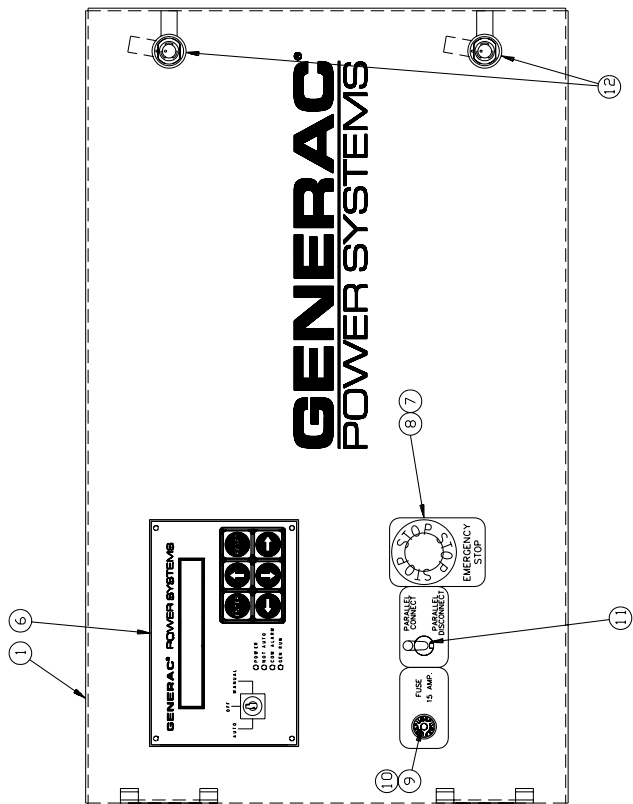

Section 7 – Exploded Views and Parts Lists

DG 50 Generator Set F Panel Door Assembly – Drawing No. C6032-G

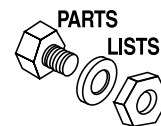

ITEM	PART NO.	QTY.	DESCRIPTION
1	C6036	1	DOOR W \ SILKSCREEN
2	C6033	1	SUB-PLATE DOOR
3	A8637	1	ASSY MK3 EXERCISER
4	63982	1	BATT CLIP-9V TRANSIS
5	29357	2	RIVET AVDEL3/32X1/8L
6	C5784	1	ASSY F-PANEL
7	98426A	1	SWITCH EMERG PB HEAD
8	98426C	1	SWITCH EMERG PB N.C.
9	32300	1	HOLDER FUSE
10	22676	1	FUSE 15A X AGC15
11	C4046	REF	SWITCH SPST 2GA51-78
12	20825	2	LATCH VICE ACTION
13	63148	4	SPACER .26 X .31 X .25 ST/ZNC
14	22473	4	WASHER FLAT 1/4 ZINC
15	22097	4	WASHER LOCK M6-1/4
16	49813	4	NUT HEX M6 -1.0 G8 YEL CHR
17	64526	8	SCREW TAP HWH #6-25 X 3/8 Z
18	64525	4	STANDOFF HEX 3/4
19	C5123	2.5FT	SEAL DOOR 3/8"X 1/4"
20	63998	1	BATTERY-9V TRANSISTR
21	C3211L	REF	SOCKET RELAY 8 PIN
22	C3211K	1	RELAY 12VDC 3PDT
23	C3211H	2	SPRING RETAINING RELAY
24	C6860	1	OVERSPEED MOD 50 PCB
25	C7013	1	SCHEMATIC WATCHDOG 50KW
26	84932	2	SCREW HHC M4-0.7 X 30 G8.8
27	22264	2	WASHER LOCK M4
28	38150	2	WASHER FLAT #8 ZINC
29	51715	2	NUT HEX M4-0.7 G8 YEL CHR
30	49226	4	WASHER LOCK M5
31	51713	4	WASHER FLAT M5
32	51716	4	NUT HEX M5-0.8 G8 YEL CHR
33	55440	4	SCREW HHC M5-0.8 X 25 G8.8
34	63378	2	CABLE-TIE HOLDER

Section 7 – Exploded Views and Parts Lists

**DG 50 Generator Set
120/208 Volt Control Panel – Drawing No. C7359-E**

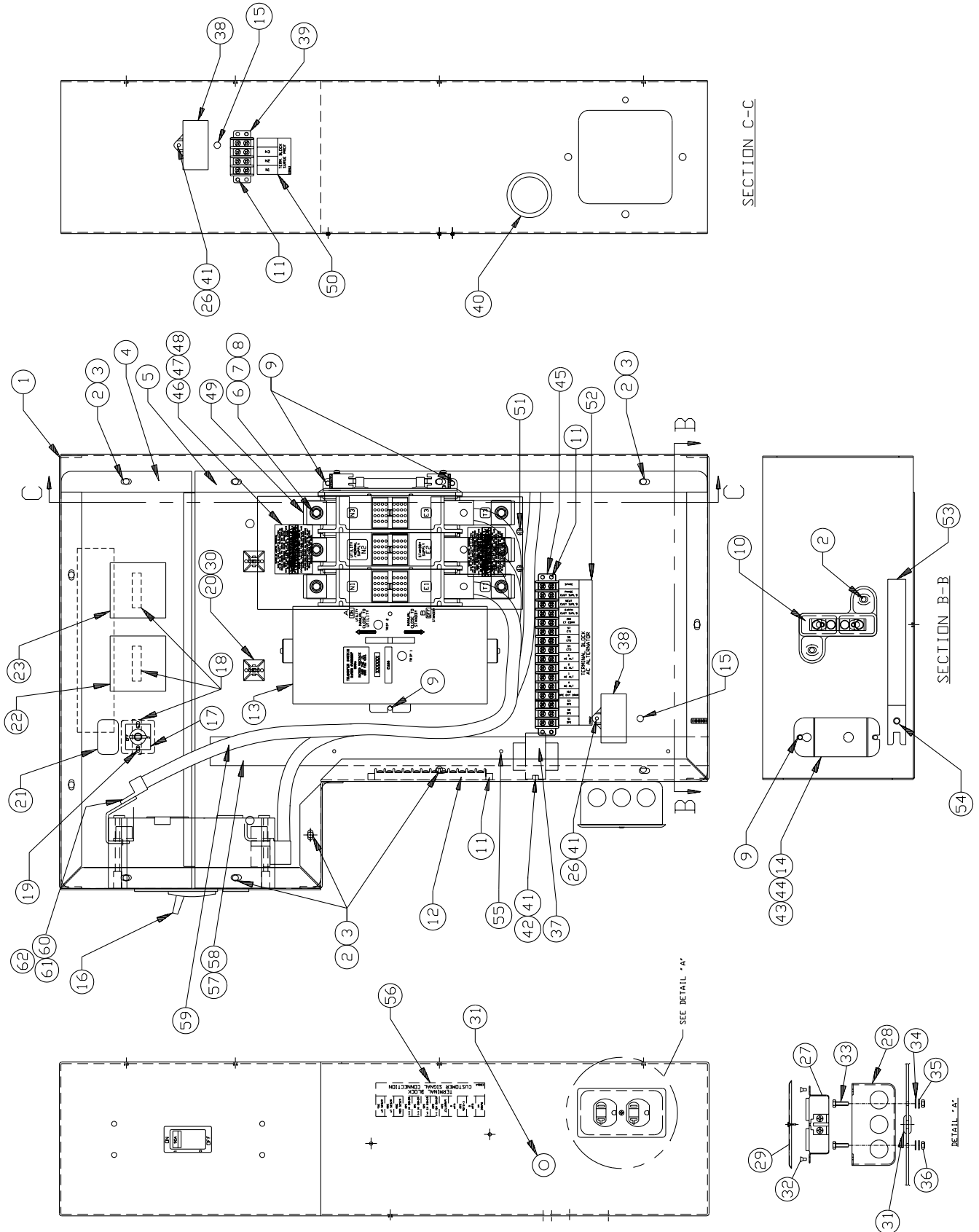

Section 7 – Exploded Views and Parts Lists

DG 50 Generator Set 120/208 Volt Control Panel – Drawing No. C7359-E

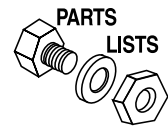

ITEM	PART NO.	QTY.	DESCRIPTION
1	C4903A	1	WLDMNT CONN BOX 120
2	90388	14	SCREW TAP M6-1.0X12 BP
3	A2115	12	WASHER NYLON .250
4	C5061	1	COVER TOP CONNECTION BOX
5	C4969	1	COVER PLATE CONNECTION BOX
6	A9949	6	LUG SLDLSS 400-#4X1/4-20 CU7AL
7	C4896	6	CRFHMS M8-1.25X20MM
8	67989	6	NUT LOCKING M8-1.25
9	74908	5	SCREW TAPTITE M5-0.8X10 BP
10	C4449	1	ASSY NEUTRAL BLOCK 100A
11	A1661	6	RIVET POP .156 X .160-.164/#20
12	55911	REF	BLOCK TERM 20A 12 X 6 X 1100V
13	C1166	1	CTTS SW-C 200A600V3P
14	63989	1	BRACKET TOGGLE SWITCH
15	45756	2	SCREW TAPTITE M6-1X10 YEL CHR
16	C7595	1	ASSY CIRCUIT BREAKER 120/208
17	74386	1	SWITCH SELECTOR VOLT/AMP 3PH
18	C4895	3	DECAL SHOCK HAZARD
19	C4979	2	SCREW TAP HWH #8-25 X 3/8 Z
20	28739A	2	TIE WRAP 4" BLACK
21	C2603	1	DECAL PH SELECT A/V
22	70043	1	METER VOLT AC 0-300
23	70045	1	AMMETER AC 0-200
24	28334	4	WASHER NYLON .187
25	C7360	1	CONNPNL HARN 208/120
26	C3992	2	SCREW TAPTITE M4-0.7 X 16 BP
27	63025	1	OUTLET 15A 120V DUPLEX
28	62141	1	HANDY BOX 2.125 DP
29	C6594	1	COVER PLATE OUTLET
30	57593	2	TIE WRAP 7" BLACK
31	89685	2	GROMMET .75 X .12 X .50
32	C6586	2	SCREW FHM #6-32 X 1/4
33	47411	2	SCREW HHC M6-1.0 X 16 G8.8
34	22473	2	WASHER FLAT 1/4 ZINC
35	22097	2	WASHER LOCK M6-1/4
36	49813	2	NUT HEX M6 -1.0 G8 YEL CHR
37	C8105	1	ASSY,56VA TRANSFORMER
38	C3932A	2	SURGEPRT RAV781BWC-4
39	46689	REF	BLOCK TERM 20A 4 X 6 X 1100V
40	36654	1	GROMMET 1-3/4 X 1/16 X 1-1/2
41	22264	4	WASHER LOCK M4
42	A1495	2	SCREW TAPTITE M4-0.7X10 BP
43	63897	1	BRKT SUPT AIR CLNR
44	55868	REF	SWITCH TOGGLE 4PDT 15A SPADE
45	43365	REF	BLOCK TERM 20A 16 X 6 X 1100V
46	C7907D	2	LUG COV3P 150/200AMP
47	C8275	4	SCREW PPHM DSEMS M4-7 X 10 ZINC
48	C8308	2	DECAL TERMINAL SHOCK HAZARD
49	26902	3	SCREW TAPTITE #8-32X1/4 BP
50	C8063	1	DECAL-UTIL SRG PRO#2
51	63378	2	CABLE-TIE HOLDER
52	C8062	1	DECAL-UTIL ALT CONN
53	63321	1	HANDLE TRANSFER SW 1-400A
54	87680	1	NUT WING M6-1.0
55	91477	3	RIVET WIRE DUCT MNT
56	C8064	1	DECAL-UTILCUSTSIGCON
57	91472	2FT	DUCT WIRING 1X1.5 6 FT
58	91472A	2FT	COVER WIRE DUCT 1 IN
59	20653621	3	CABLE CB TO TS 5.7L
60	23152	3	SCREW HHC 3/8-16 X 3/4 G5
61	22241	3	NUT HEX 3/8-16 STEEL
62	22237	3	WASHER LOCK 3/8

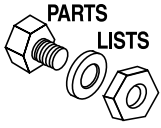

Section 7 – Exploded Views and Parts Lists

DG 50 Generator Set

480/277 Volt Control Panel – Drawing No. C5334-F

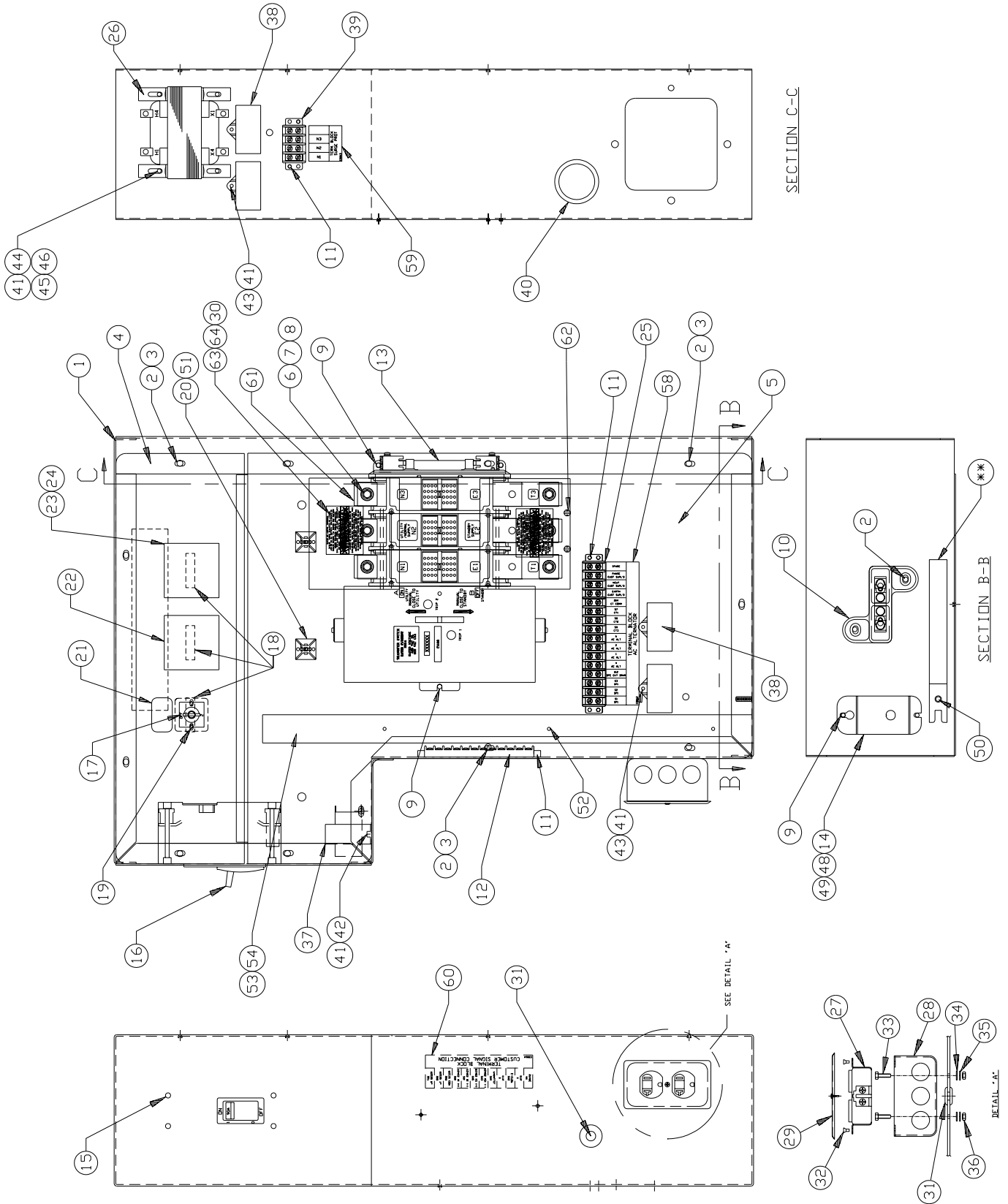

Section 7 – Exploded Views and Parts Lists

**DG 50 Generator Set
480/277 Volt Control Panel – Drawing No. C5334-F**

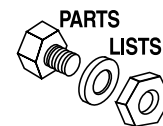

ITEM	PART NO.	QTY.	DESCRIPTION	ITEM	PART NO.	QTY.	DESCRIPTION
1	C4903	1	WLDMNT CONN BOX 480	35	22097	2	WASHER LOCK M6-1/4
2	90388	14	SCREW TAP M6-1.0 X 12 BP	36	49813	2	NUT HEX M6 -1.0 G8 YEL CHR
3	A2115	12	WASHER NYLON .250	37	C8105	1	ASSY 56VA TRANSFORMER
4	C5061	1	COVER CONN BOX TOP	38	C8102	4	ASSY SURGE PROTECT
5	C4969	1	COVER PLATE CONN BOX	39	46689	REF	BLOCK TERM 20A 4 X 6 X 1100V
6	A9949	6	LUG SLDLSS 400-#4 X 1/4-20 CU7AL	40	36654	1	GROMMET 1-3/4 X 1/16 X 1-1/2
7	C4896	6	CRFHMS M8-1.25 X 20MM	41	22264	10	WASHER LOCK M4
8	67989	6	NUT LOCKING M8-1.25	42	A1495	2	SCREW TAPTITE M4-0.7X10 BP
9	74908	5	SCREW TAPTITE M5-0.8 X 10 BP	43	C3992	4	SCREW TAPTITE M4-0.7 X 16 BP
10	C4449	1	ASSY NUTRL BLK 100A	44	43180	4	WASHER FLAT M4
11	A1661	6	RIVET POP .156 X .160-.164/#20	45	51715	4	NUT HEX M4-0.7 G8 YEL CHR
12	55911	REF	BLOCK TERM 20A 12 X 6 X 1100V	46	51787	4	SCREW HHC M4-0.7 X 16 G8.8
13	C1166	1	CTTS SW-C 200A 600V 3P	47	C5174	1	HARNESS 50KW UTL F PANEL CN BX
14	63989	1	BRACKET TOGGLE SWITCH	48	63987	1	DECAL SAFETY DISCONNECT
15	22471	4	NUT HEX #8-32 STEEL	49	55868	REF	SWITCH TOGGLE 4PDT 15A SPADE
16	C7958	1	ASSY CIRCUIT BREAKER	50	87680	1	NUT WING M6-1.0
17	74386	1	SWITCH SELCT 3PH VOLT/AMP	51	57593	2	TIE WRAP 7" BLACK
18	C4895	3	DECAL SHOCK HAZARD	52	91477	3	RIVET WIRE DUCT MNT
19	C4979	2	SCREW TAP HWH #8-25 X 3/8 Z	53	91472	3 FT	DUCT WIRING 1 X 1.5 6 FT
20	28739A	2	TIE WRAP 4" BLACK	54	91472A	2 FT	COVER WIRE DUCT 1 IN
21	C2603	1	DECAL PH SELECT A/V	55	203-53621	1	WIRE LEADS ATS E1 TO C/B (NOT SHOWN)
22	70044	1	METER VOLT AC 0-600				
23	70048	1	AMMETER SCALE 0-100	56	204-53621	1	WIRE LEADS ATS E2 TO C/B (NOT SHOWN)
24	70045	1	AMMETER AC 0-200				
25	43365	REF	BLOCK TERM 20A 16 X 6 X 1100V	57	205-53621	1	WIRE LEADS ATS E3 TO C/B (NOT SHOWN)
26	64126	1	TRANSFRM 240/480V-120/240V				
27	63025	1	OUTLET 15A 120V DUPLEX	58	C8062	1	DECAL UTIL ALT CONN
28	62141	1	BOX HANDY 2.125 DP	59	C8063	1	DECAL UTIL SRG PRO#2
29	C6594	1	COVER PLATE OUTLET	60	C8064	1	DECAL UTIL CUST SIGNAL CONN
30	C8308	2	DECAL TERMINAL SHOCK HAZARD	61	26902	3	SCREW TAPTITE #8-32 X 1/4 BP
31	89685	2	GROMMET .75 X .12 X .50	62	63378	2	HOLDER CABLE TIE
32	C6586	2	SCREW FHM #6-32 X 1/4	63	C7907D	2	LUG COV3P 150/200AMP
33	47411	2	SCREW HHC M6-1.0 X 16 G8.8	64	C8275	4	SCREW PPHM DSEMS M4-7 X 10 ZNC
34	22473	2	WASHER FLAT 1/4 ZINC	65	63321	1	HANDLE XFER SWITCH 1- 400A



Section 7 – Exploded Views and Parts Lists

**DG 50 Generator Set
Mounting Base – Drawing No. C5714-C**

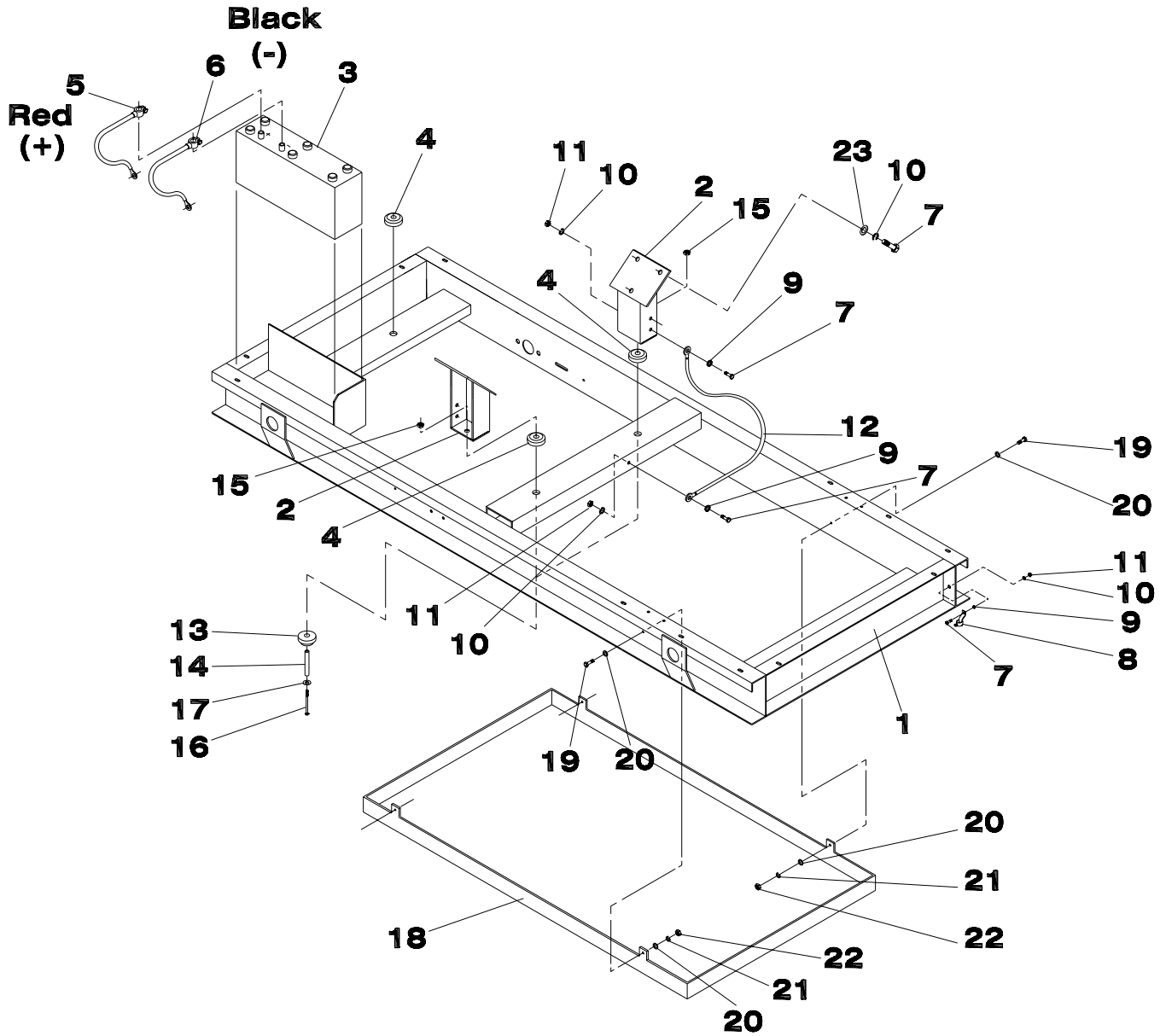

ITEM	PART NO.	QTY.	DESCRIPTION	ITEM	PART NO.	QTY.	DESCRIPTION
1	A9658	1	BASE MOUNTING 50KW UTILITY	13	52252	4	DAMPENER VIBRATION
2	C4743	2	MOUNT ENGINE 5.7L	14	52257	4	SPACER .49X.62X1.87 PWDR/ZINC
3	C3100	1	BATTERY 12VDC 460A F-3ET	15	52860	4	NUT LOCKING M12-1.75
4	52251A	4	DAMPENER VIB 50 WHITE	16	55597	4	SCREW HHC M12-1.75 X 85 G8.8
5	38804U	1	CABLE BATT RED #1 X 28.00	17	52259	4	WASHER FLAT M12
6	38805J	1	CABLE BATT BLK #1 X 30.00	18	C2409	1	PAN SPILL 5.7L
7	29745	9	SCREW HHC 3/8-16 X 1 G5	19	47411	4	SCREW HHC M6-1.0 X 16 G8.8
8	61383	1	LUG SLDLSS 3/0-#4X13/32 CU	20	22473	8	WASHER FLAT 1/4 ZINC
9	25507	3	WASHER SHAKEPROOF EXT 7/16 STL	21	22097	4	WASHER LOCK M6-1/4
10	22237	9	WASHER LOCK 3/8	22	49813	4	NUT HEX M6 -1.0 G8 YEL CHR
11	22241	3	NUT HEX 3/8-16 STEEL	23	22131	6	WASHER FLAT 3/8 ZINC
12	98-53621	1	ASSY GROUND WIRE				

Section 7 – Exploded Views and Parts Lists

**DG 50 Generator Set
Block Heater – Drawing No. C8807-B**

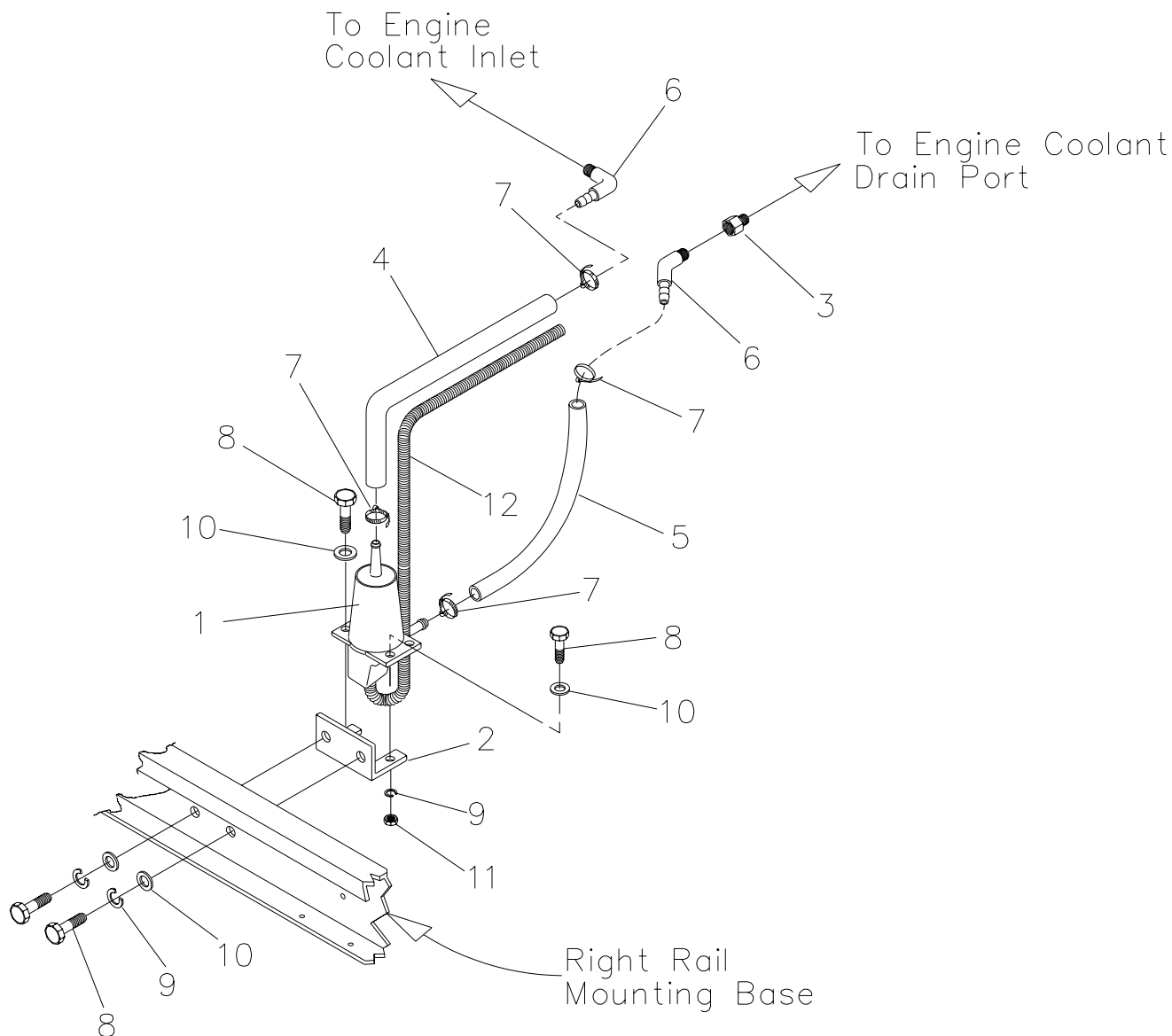
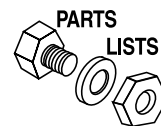

ITEM	PART NO.	QTY.	DESCRIPTION
1	C7850	1	BLOCK HEATER ASSEM.
2	84427	1	BRACKET, HEATER
3	62303	1	ADAPTOR 1/4" NPT TO 3/8" NPT
4	50967	23"	HOSE RES 5/8 RIA 250F
5	50967	20"	HOSE RES 5/8 RIA 250F
6	34339	2	BARB ELBOW 5/8 X 3/8 X 1.13
7	57823	4	CLAMP HOSE #10 .56 - 1.06
8	47411	4	SCREW HHC M6-1.0 X 16 G8.8
9	22097	4	WASHER LOCK M6-1/4
10	22473	4	WASHER FLAT 1/4 ZINC
11	49813	2	NUT HEX M6 -1.0 G8 YEL CHR
12	77043A	30"	FLEX CONDUIT .38 ID

Section 7 – Exploded Views and Parts Lists

**DG 50 Generator Set
Radiator – Drawing No. C6461-C**

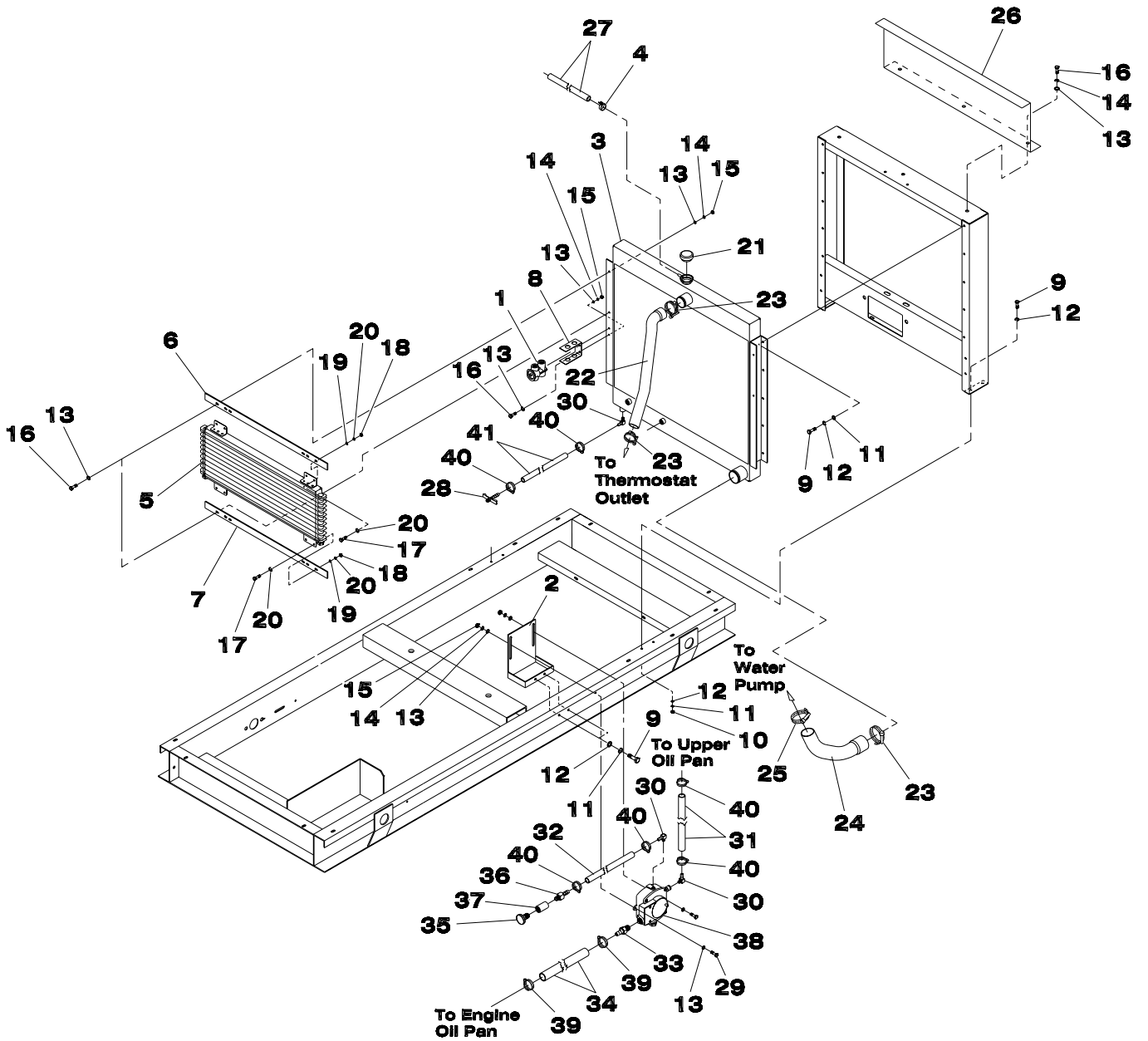

Section 7 – Exploded Views and Parts Lists

DG 50 Generator Set Radiator – Drawing No. C6461-C

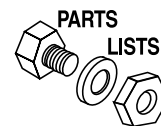

ITEM	PART NO.	QTY.	DESCRIPTION
1	C4811	1	THERMOSTAT OIL
2	C4410	1	BRKT MTG RENN OIL FLOAT VALVE
3	A9847	1	RADIATOR 5.7L
4	C7649	1	CLAMP SPRING (7/8"-3/8")
5	A8825	1	COOLER OIL
6	C4494	1	BRACKET UPPER -OIL COOLER
7	C4495	1	BRACKET LOWER -OIL COOLER
8	C4252	1	BRACKET THERMOSTAT
9	42907	16	SCREW HHC M8-1.25 X 16 G8.8
10	51716	4	NUT HEX M5-0.8 G8 YEL CHR
11	22129	12	WASHER LOCK M8-5/16
12	22145	16	WASHER FLAT 5/16 ZINC
13	22473	19	WASHER FLAT 1/4 ZINC
14	22097	11	WASHER LOCK M6-1/4
15	49813	8	NUT HEX M6 -1.0 G8 YEL CHR
16	47411	9	SCREW HHC M6-1.0 X 16 G8.8
17	51718	8	SCREW HHC M4-0.7 X 10 G8.8
18	51715	8	NUT HEX M4-0.7 G8 YEL CHR
19	22264	8	WASHER LOCK M4
20	22985	16	WASHER FLAT #6 ZINC
21	46627	1	CAP RADIATOR
22	C5373	1	HOSE UPPER RADIATOR 5.7L
23	42561	3	CLAMP HOSE #36 1.88 - 2.75
24	C8016	1	HOSE LOWER RAD. 5.7L
25	35685	1	CLAMP HOSE #28 1.32 - 2.25
26	C3183	1	BLOCK OFF AIR TOP
27	47290	5 FT.	HOSE RES 3/8 SINGLE BRAID
28	36865	1	DRAINCOCK
29	38750	2	SCREW HHC M6-1.0 X 30 G8.8
30	49340	3	BARB ELBOW 3/8 X 1/4 X 1.04
31	47290	3.5FT.	HOSE RES 3/8 SINGLE BRAID
32	47290	4.5 FT.	HOSE RES 3/8 SINGLE BRAID
33	44117	1	STRAIGHT BRBD 3/8NPT X 5/8
34	65386	6"	HOSE 5/8 ID SAE100R6
35	26847	1	BREATHER
36	55596	1	STRAIGHT BRBD 3/8NPT X 3/8
37	25066	1	COUPLING FULL 3/8-18
38	C4978	1	SWITCH OIL LEVEL
39	35472	2	CLAMP HOSE #6 .43 - .78
40	86133N	6	CLAMP HI TORQUE 6.75 - 7.625
41	47290	3.5 FT.	HOSE RES 3/8 SINGLE BRAID

Section 7 – Exploded Views and Parts Lists

**DG 50 Generator Set
Alternator – Drawing No. C9060-C**

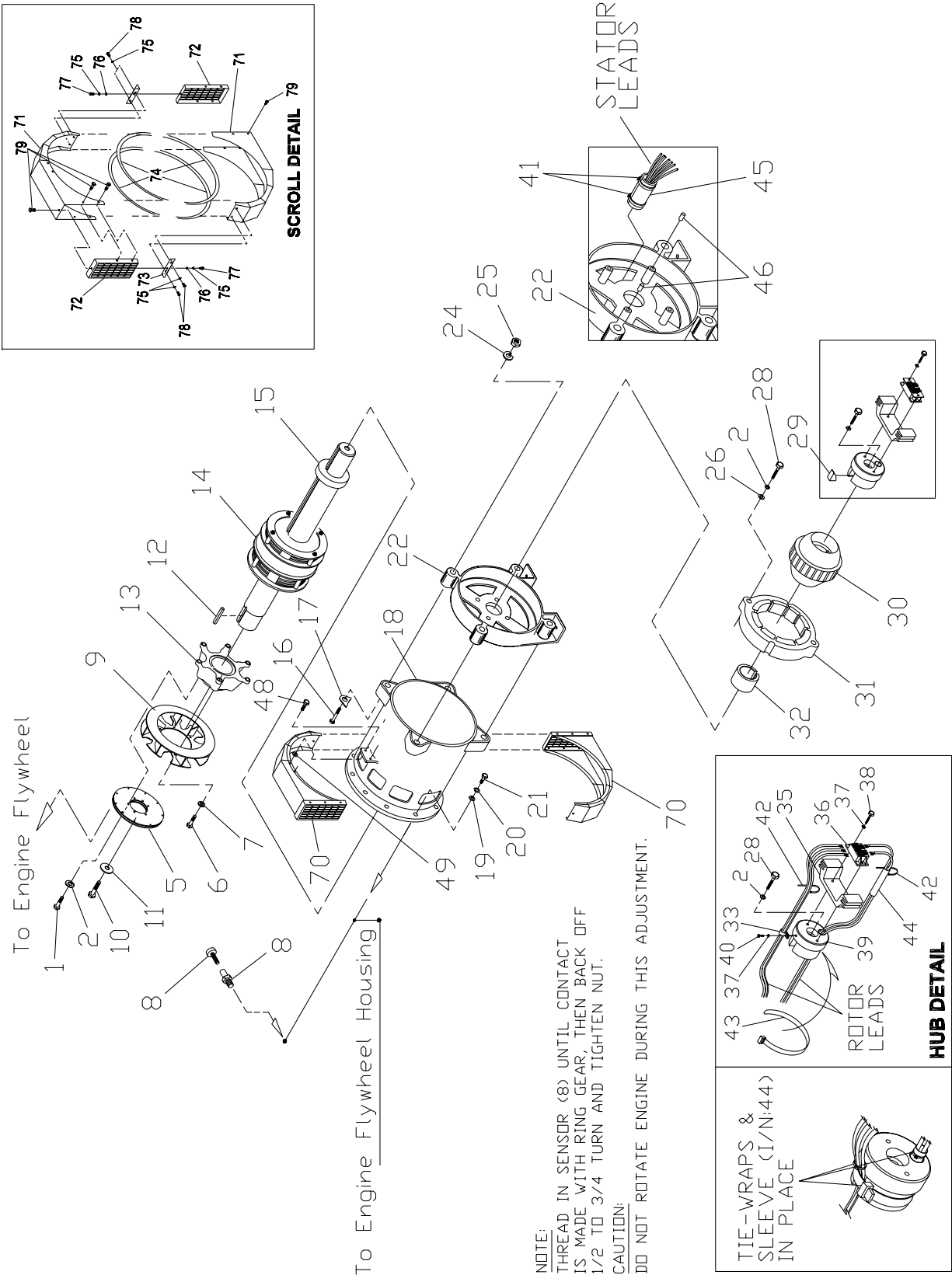

Section 7 – Exploded Views and Parts Lists

**DG 50 Generator Set
Alternator – Drawing No. C9060-C**

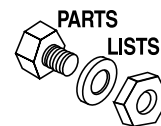

ITEM	PART NO.	QTY.	DESCRIPTION
1	51768	6	SCREW HHC M12-1.75 X 25 G8.8
2	51769	9	WASHER LOCK M12
5	A3852	2	PLATE FLEX GM
6	39253	6	SCREW HHC M8-1.25 X 20 G8.8
7	22129	6	WASHER LOCK M8-5/16
8	82130D	1	ASSY MAG PICKUP 72"
9	C4286	1	ASSY FAN W/PRESS DISC 10.75X3
10	A2601	1	SCREW HHC M16-2.0 X 45 G8.8
11	A2602	1	WASHER FLAT SPECIAL .688 I.D.
12	A1138	1	KEY SQ 3/8 X 2-1/2 STEEL
13	21941	1	COUPLER 390 SAE
14	C4746	1	ASSY ROTOR 50KW 4 POLE
15	52624	1	BEARING BALL 6212 SEALED
16	A5580	4	SCREW HHC M14-2.0 X 140 G8.8
17	A1633	4	WASHER,390 SAE ALT.
18	C4747	1	ASSY STATOR 50KW 277/480V
	D3228	1	ASSY STATOR 50KW 120/208V
19	22131	12	WASHER FLAT 3/8 ZINC
20	46526	12	WASHER LOCK M10
21	57642	2	SCREW HHC M10-1.5 X 40 G10.9
22	68113	1	CARRIER REAR BRG 15"
24	43123	4	WASHER LOCK M14
25	51779	4	NUT HEX M14-2 G8 YEL CHR
26	52259	2	WASHER FLAT M12
28	68406	3	SCREW HHC M12-1.75 X 60 G10.9
29	72878	1	KEY SQ 3/8 X 3-1/4 STEEL
30	87272	1	ASSY EXCITER 2.00" STK
31	68405	1	EXCITER FIELD 15" 2" LG
32	92950	1	COLLAR SLIP FIT 390 MM
33	20151	1	CLAMP VINYL .312 X .203 Z
35	90063	1	BRIDGE SUPPORT DIODE 15"
36	90152	1	ASSY BRIDGE RECTIFIER
37	23365	3	WASHER SHAKEPROOF INT #8
38	33143	2	SCREW HHM #8-32 X 7/8
39	90064	1	CAP END 390MM ROTOR
40	33133	1	SCREW HHM #8-32 X 3/8
41	31980	2	WRAP TIE 11" WHITE
42	28739A	2	WRAP TIE 4" BLACK
43	85662D	1	WRAP TIE 15.25 X .19 BLK NYLON
44	22661L	1	SLEEVE UL #0 .330 ID
45	83549	1	SLEEVE-RUBBER
46	22392	2	PIN DOWEL 1/2 X 1-1/4
48	A2110	2	SCREW SWAGE 1/4-20 X 1/2 Z/YC
49	22473	2	WASHER FLAT 1/4 ZINC
53	C8026	1	COATING PROTECTIVE (NOT SHOWN)
70	A4089	1	ASSY SCROLL 390 SAE
71	A2491	2	SHROUD ALT SHEET METAL
72	A2497	2	SCREEN SHROUD SAE
73	A2496	2	BRKT TENSIONER SAE SCROLL
74	56326	8.4'	TRIM VINYL BLACK 1/8GP
75	22097	6	WASHER LOCK M6-1/4
76	49811	2	WASHER FLAT M6
77	45757	2	SCREW HHC M6-1.0 X 25 G8.8
78	43116	4	SCREW HHC M6-1.0 X 12 G8.8
79	A2437	10	SCREW SWAGE 1/4-20 X 5/8 Z/YC

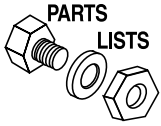

Section 7 – Exploded Views and Parts Lists

DG 50 Generator Set

Compartment – Drawing No. C4733-C

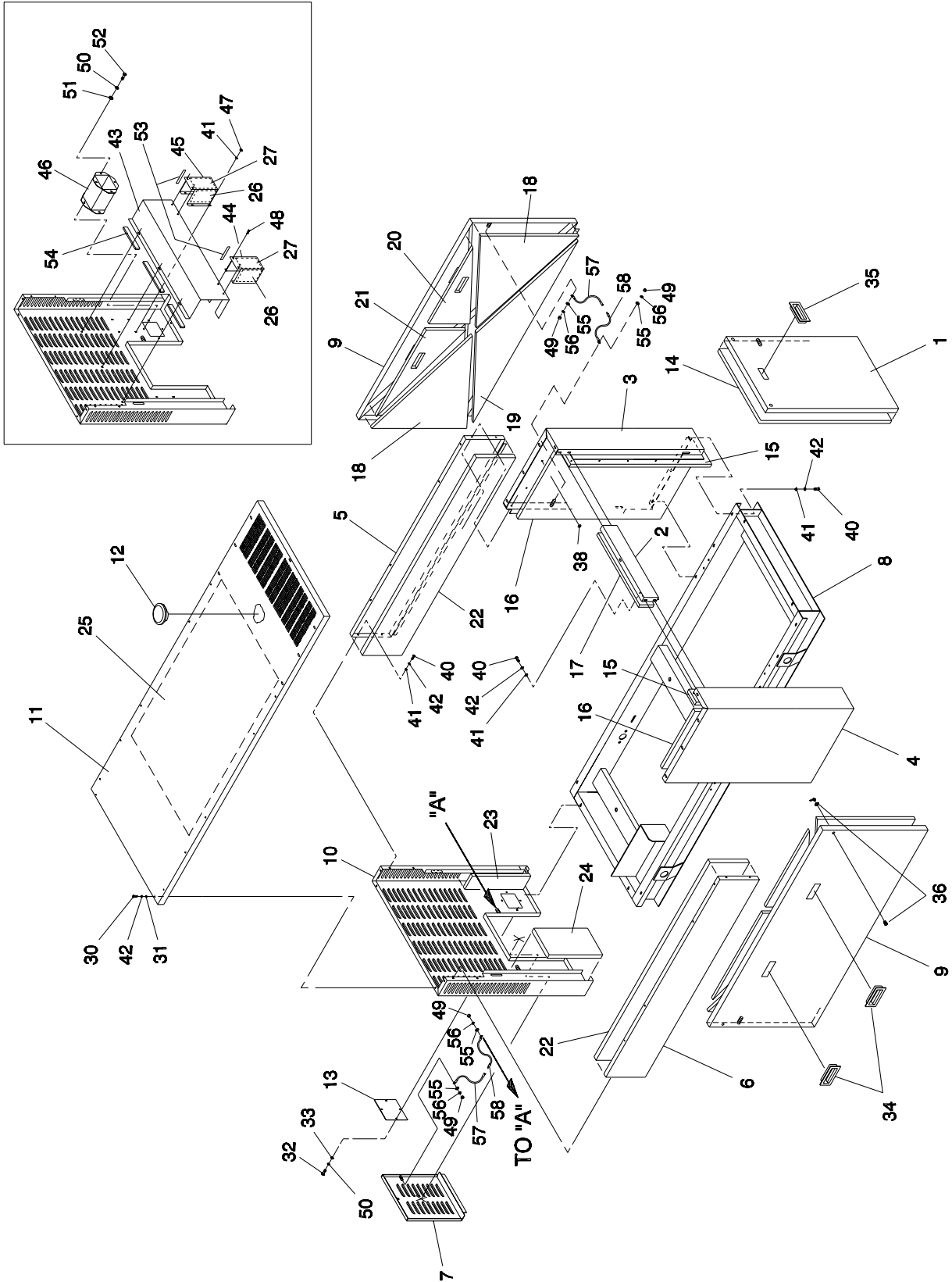

Section 7 – Exploded Views and Parts Lists

DG 50 Generator Set Compartment – Drawing No. C4733-C

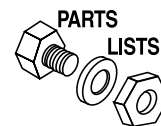

ITEM	PART NO.	QTY.	DESCRIPTION
1	C2916	1	DOOR FRONT 5.7L
2	C2911	1	SUPPORT FRONT 5.7L
3	C1499	1	POST CORNER LH FRONT
4	C1499A	1	POST CORNER RH FRONT
5	C1202	1	SUPPORT LH TOP
6	C1202A	1	SUPPORT RH TOP
7	C9444	1	DOOR REAR ACCESS
8	A9658	REF.	BASE MOUNTING 50 KW UTILITY
9	C1447	2	WELDMENT 5.7 UTILITY DOOR
10	C4277	1	WELDMENT PANEL REAR END
11	C1953	1	ROOF 5.7L
12	C2634A	1	ACCESS COVER ASSEMBLY
13	C5029	1	PLATE UTILITY-IN GLAND
14 *	C4334	1	CERWOOL FRONT DOOR
15 *	C4334A	2	CERWOOL C-POST FRONT
16 *	C4334B	2	CERWOOL C POST SIDE
17 *	C4334C	1	CERWOOL FRONT DOOR
18 *	C4334D	4	CERWOOL SIDE DOOR UPPER
19 *	C4334E	2	CERWOOL SIDE DOOR LOWER
20	C3201K	2	INSULATION SIDE DOOR
21	C3201J	2	INSULATION SIDE DOOR
22	C3201B	2	INSULATION SUPPORT TOP
23	C3201H	2	INSULATION REAR PANEL SIDE
24	C3201G	1	INSULATION REAR PANEL BOTTOM
25	C3201A	1	INSULATION ROOF
26	C3201C	4	INSULATION ALT AIR INLET SIDE
27	C3201D	2	INSULATION ALT AIR INLET BACK
30	C3181	17	SCREW BHSC M8-1.25 X 20 SS
31	27756	17	WASHER NYLON .312
32	A3359	4	SCREW BHSC M6-1.0 X 16 SS
33	A2115	4	WASHER NYLON .250
34	C3180	4	HANDLE DOOR
35	20823	1	HANDLE PVC BLACK
36	20825	7	LATCH VICE ACTION
37	20826	2	KEY VICE ACTION LATCH (NOT SHOWN)
38	78115	97	WASHER SELF LOCKING DOME
39	C8150	33.5'	SEAL RUBBER DOOR (NOT SHOWN)
40	42907	24	SCREW HHC M8-1.25 X 16 G8.8
41	22129	52	WASHER LOCK M8-5/16
42	22145	41	WASHER FLAT 5/16 ZINC
43	C3707	1	DUCT ALTERNATOR TOP
44	C3708	1	DUCT RH SIDE ALT AIR INLET
45	C4961	1	DUCT LH SIDE ALT AIR INLET
46	C5042	1	WELDMENT UTILITY IN BOX
47	22259	11	NUT HEX 5/16-18 STEEL
48	66849B	2	SCREW TAPTITE M5-0.8 X 8 BP
49	28430	8	NUT HEX #10-24 STEEL
50	22097	8	WASHER LOCK M6-1/4
51	22473	4	WASHER FLAT 1/4 ZINC
52	47411	4	SCREW HHC M6-1.0 X 16 G8.8
53	56326	1 FT.	TRIM VINYL BLACK 1/8 GP
54	29451	7.5 FT.	TAPE ELEC UL FOAM 1/8 X 1/2
55	23897	8	WASHER FLAT #10 ZINC
56	23762	8	WASHER SHAKEPROOF EXT #10 STL
57	208-53621	4	ASSY WIRE 14 AWG 6" PLUG
58	145-53621	4	ASSY WIRE 14 AWG 6" RECPT

* HEAT INSULATION KIT P/N C3788

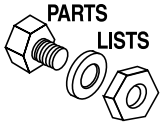

Section 7 – Exploded Views and Parts Lists

DG 50 Generator Set
Fan Drive – Drawing No. C4849-C

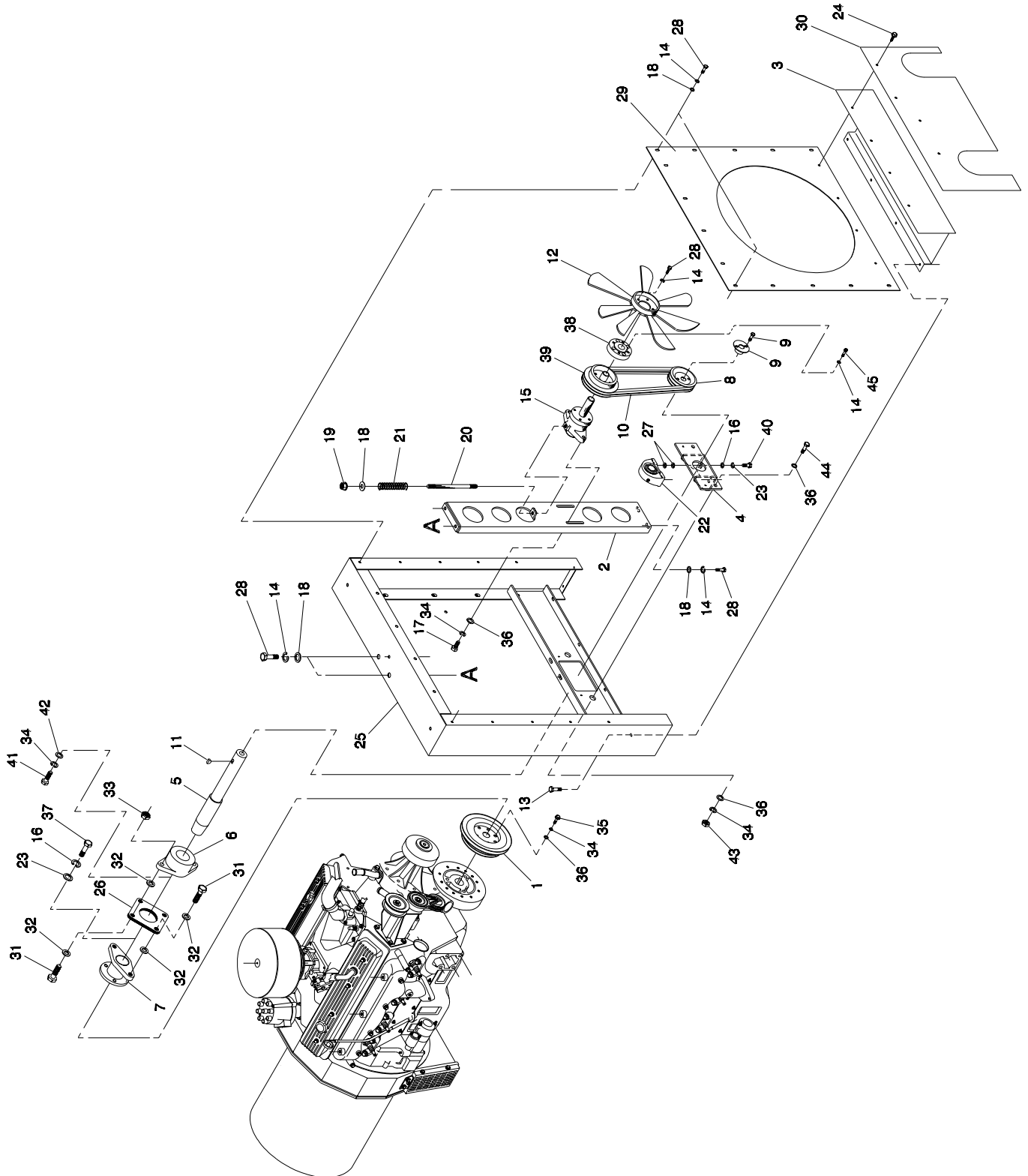

Section 7 – Exploded Views and Parts Lists

**DG 50 Generator Set
Fan Drive – Drawing No. C4849-C**

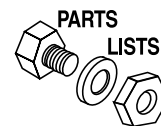

ITEM	PART NO.	QTY.	DESCRIPTION
1	A4239	1	PULLEY CRANKSHAFT
2	C1726	1	BRACKET BELT TENSIONER
3	C4349	1	SUPPORT VENTURI BOTTOM
4	C6452	1	BRACKET BEARING SUPPORT
5	C6475	1	SHAFT FLEX DRIVE 5.7
6	C6500	1	HUB FLEX COUPLING
7	C6503	1	HUB FLEX COUPLING
8	C2737	1	SHEAVE TWO-GROOVE 5.7L
9	C4326	1	SHEAVE HUB H 1.125
10	C6549	1	V-BELT GREEN 49.0"
11	24853	1	KEY WOODRUFF #91
12	98184	1	FAN-COOLING 26"
13	74908	4	SCREW TAPTITE M5-0.8X10 BP
14	22129	27	WASHER LOCK M8-5/16
15	C8701	1	ASSY FAN SUPPORT
16	22250	2	WASHER FLAT 7/16
17	57642	2	SCREW HHC M10-1.5 X 40 G10.9
18	22145	23	WASHER FLAT 5/16 ZINC
19	52858	1	NUT LOCK M8
20	BY45761	1	STUD M8-1.25 X 200 G5 ZINC
21	42962	1	SPRING COMPRESSION
22	C8364	1	ASSY PILLOW BLOCK
23	22302	2	WASHER LOCK 7/16
24	56892	4	SCREW CRIMPTITE #10-24 X 3/8
25	C8306	1	SUPPORT RADIATOR WLDMENT.
26	C7043	14	DISK FLEX
27	C8126	4	WASHER BELLVILLE .442 I.D.
28	42907	27	SCREW HHC M8-1.25 X 16 G8.8
29	A9853	1	VENTURI, 50KW 5.7L
30	C3202	1	BLOCKOFF BOTTOM 5.7
31	C8146	4	BOLT 5/16-24X1.25
32	C8145	8	WASHER FLEX (THIN)
33	C8165	2	NUT LOCK HEX 5/16-24 NYL INS
34	22237	10	WASHER LOCK 3/8
35	C5713	3	SCREW SHC 3/8-24X1-1/2
36	22131	13	WASHER FLAT 3/8 ZINC
37	A7814	1	SCREW HHC 7/16-20 X 3-1/4
38	A7885	1	ADAPTOR FAN 7.4
39	58793	1	PULLEY AUTO 7.00 PD
40	26359	2	SCREW HHC 7/16-14 X 3/4 G5
41	49814	1	SCREW HHC M10-1.5 X 25 G8.8
42	52644	1	SPACER .5 X 1.5 X .25 ST/ZNC
43	22241	4	NUT HEX 3/8-16 STEEL
44	29745	4	SCREW HHC 3/8-16 X 1 G5
45	49821	4	SCREW SHC M8-1.25 X 30 G12.9

Section 7 – Exploded Views and Parts Lists

**DG 50 Generator Set
Engine Parts – Drawing No. C5715-C**

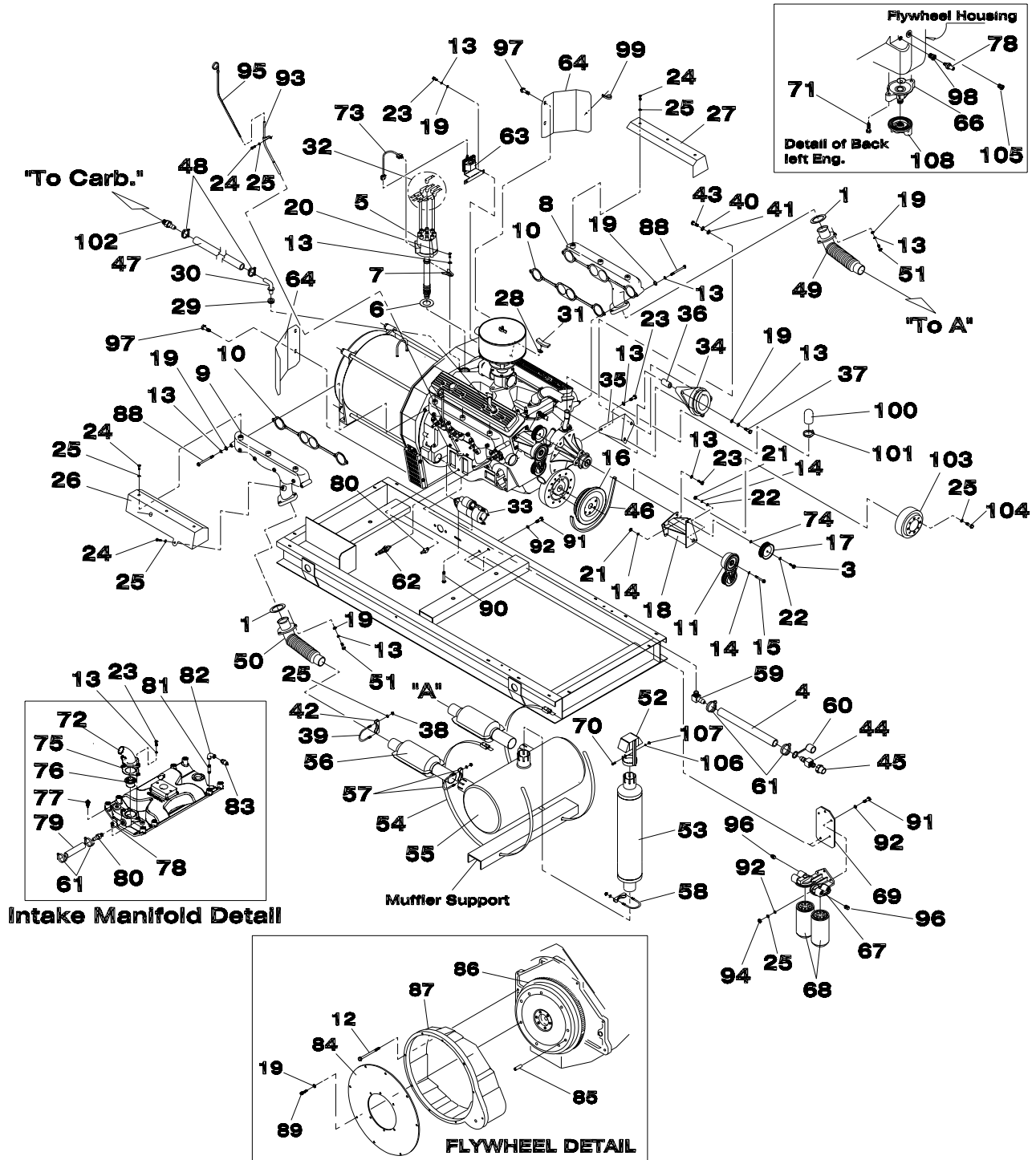

TORQUE SETTINGS

TORQUE PATTERNS

Exhaust Manifold (First of Qty. 2 I/N: 49)	
1st Pass	15 N-M (11 lb-ft)
Final Pass	30 N-M (22 lb-ft)
	7 5 3 1 2 4 6 8

Section 7 – Exploded Views and Parts Lists

DG 50 Generator Set Engine Parts – Drawing No. C5715-C

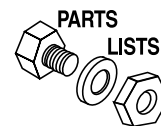

ITEM	PART NO.	QTY.	DESCRIPTION	ITEM	PART NO.	QTY.	DESCRIPTION
1	44149	2	GASKET EXHAUST RING	55	C1551	1	MUFFLER HORIZONTAL 5.7L
2	C7021	1	ENG. HARNESS DG50 (NOT SHOWN)	56	C3151	2	CATALYTIC CONVERTER 5.7L 3 WAY
3	57645	1	SCREW HHC M10-1.5 X 50 G8.8	57	C6119	2	BOLT U 5/16-18 X 2-1/4
4	50967	2 FT.	HOSE RES 5/8 RIA 250F	58	55978	1	BOLT U 3/8-16 X 3.25
5	C4386	1	DISTRIBUTOR, EST	59	56460	1	ELBOW BARB 5/8 X 1/2 X 1.21
6	C4389	1	GASKET, DISTRIBUTOR	60	C3158	1	COVER DUST
7	C4254	1	HOLD-DOWN, DISTRIBUTOR	61	35472	4	CLAMP HOSE #6 .43 - .78
8	C3061	1	EXH. MANIFOLD-L.H.	62	59503	8	SPARK PLUG 57&74
9	C3061A	1	EXH, MANIFOLD-R.H.	63	C4385	1	IGNITION COIL
10	55489	2	GASKET, EXH. MANIFOLD	64	C4288	2	DEFLECT,ALT AIR EXIT
11	C2885A	1	PULLEY, BELT TENSIONER	65	C4815	1	5.7L OIL LINE KIT (NOT SHOWN)
12	32303	6	SCREW HHC 3/8-16 X 3-1/2 G5	66	58008	1	ADAPTOR OIL FILTER
13	22237	33	WASHER LOCK 3/8	67	C4812	1	FILTER OIL REMOTE
14	46526	5	WASHER LOCK M10	68	C3784	2	FILTER OIL 5.7L
15	C3756	1	BOLT, TENSIONER PULLEY	69	C4229	1	BRACKET OIL FILTER
16	REF.	1	PULLEY, CRANK SHAFT	70	51767	1	SCREW HHC M6-1.0 X 45 G8.8
17	A4241A	1	PULLEY, GROOVED IDLER	71	58007	2	BOLT OIL FILTER
18	C6233	1	MOUNTING BRACKET ASSEMBLY	72	69939	1	HOUSING THERMOSTAT
19	22131	29	WASHER FLAT 3/8 ZINC	73	A4244	1	CONNECT COIL TO DIST
20	25017	1	SCREW HHC 3/8-16 X 1/2 G5	74	52259	2	WASHER FLAT M12
21	45772	2	NUT HEX M10-1.5 G8 YEL CHR	75	48665	1	GASKET THERMOSTAT
22	A5768	2	WASHER FLAT HEAVY DUTY	76	75885	1	THERMOSTAT 195 DEG F
23	29745	8	SCREW HHC 3/8-16 X 1 G5	77	35606	1	SENSOR HI COOLANT SHUTDOWN
24	36223	9	SCREW HHC 5/16-18 X 1/2 G5	78	53667	2	SENDER WATER TEMP
25	22129	20	WASHER LOCK M8-5/16	79	A6283	1	HOSE PREFORMED BLOCK HEATER
26	C4967A	1	R.H. HEATSHIELD	80	44117	2	STRAIGHT BRBD 5/8 X 3/8 X 1.72
27	C4967	1	L.H. HEATSHIELD	81	39558	1	NIPPLE PIPE 1/8 NPT X 1-3/4
28	C5320	1	GROMMET BREATHER 5.7L	82	28405	1	ELBOW 90D 1/8 NPT
29	C5318	1	GROMMET PVC 5.7L	83	53666	1	SENDER OIL PRESSURE
30	A4121	1	PCV VALVE	84	A3852	3	PLATE FLEX GM
31	69870	1	BREATHER CRANKCASE	85	48191	2	PIN DOWEL M10 X 24
32	C4701	1	WIRE SET SPARK PLUG	86	C3154	1	FLYWHEEL REWORK
33	59056A	1	STARTER 5.7L/7.4L GM	87	98239	1	CASTING ADAPTOR
34	C6234	1	ALTERNATOR DC ASSEMBLY 5.7L	88	31678	12	SCREW HHC 3/8-16 X 3-3/4 G5
35	21928	1	BRACKET ALTERNATOR SUPPORT	89	43097	8	SCREW SH 3/8-16 X 1 G8.8 NZ
36	A5737C	1	SPACER DC ALTERNATOR	90	58385	2	BOLT STARTER
37	33819	1	SCREW HHC 3/8-16 X 4 G5	91	43107	5	SCREW HHC M8-1.25 X 25 G8.8
38	22259	4	NUT HEX 5/16-18 STEEL	92	22145	7	WASHER FLAT M8-5/16 ZINC
39	36434	2	U-BOLT 2" 5/16"-18	93	58365	1	TUBE DIPSTICK OIL
40	46526	2	WASHER LOCK M10	94	45771	5	NUT HEX M8-1.25 G8 YEL CHR
41	A5768	2	WASHER FLAT HEAVY DUTY	95	58366	1	DIPSTICK OIL
42	36449	2	SADDLE 2 INCH	96	24310	2	PLUG STD PIPE 1/2 STEEL SQ HD
43	49814	2	SCREW HHC M10-1.5 X 25 G8.8	97	A2437	5	SCREW SWAGE 1/4-20 X 5/8 Z/YC
44	44118	1	STRAIGHT BRBD 1/2NPT X 5/8	98	35579	1	BUSHING REDUCER 1/4 TO 1/8
45	C3159	1	DISCONNECT QUICK 1/2 NPT MALE	99	55934N	1	CLAMP VINYL 1.31 X .281 Z
46	C5482	1	BELT 5.7L SERPENTINE	100	77996	1	CAP HOSE
47	47290	1 FT.	HOSE RES 3/8 SINGLE BRAID	101	57822	1	CLAMP HOSE #8 .53 - 1.00
48	86133N	2	CLAMP HI TORQUE 6.75 - 7.625	102	35461	1	STRAIGHT BRBD 1/4NPT X 3/8
49	C3782	1	EXHAUST FLEX LH 5.7L	103	A4240	1	PULLEY WATER PUMP
50	C3783	1	EXHAUST FLEX RH 5.7L	104	42907	4	SCREW HHC M8-1.25 X 16 G8.8
51	22746	6	SCREW HHC 3/8-16 X 1-3/4 G5	105	35579	1	BUSHING REDUCER 1/4 TO 1/8
52	C3199	1	HAT MUFFLER 5.7L	106	22097	1	WASHER LOCK M6-1/4
53	C1552	1	MUFFLER VERTICAL 5.7L	107	49813	1	NUT HEX M6 -1.0 G8 YEL CHR
54	86133G	2	CLAMP HI TORQUE 3.75 - 4.625	108	C5899	1	ADAPTOR UNIVERSAL SPIN ON

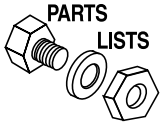

Section 7 – Exploded Views and Parts Lists

DG 50 Generator Set

Control Panel & Connection Box – Drawing No. C6462-D

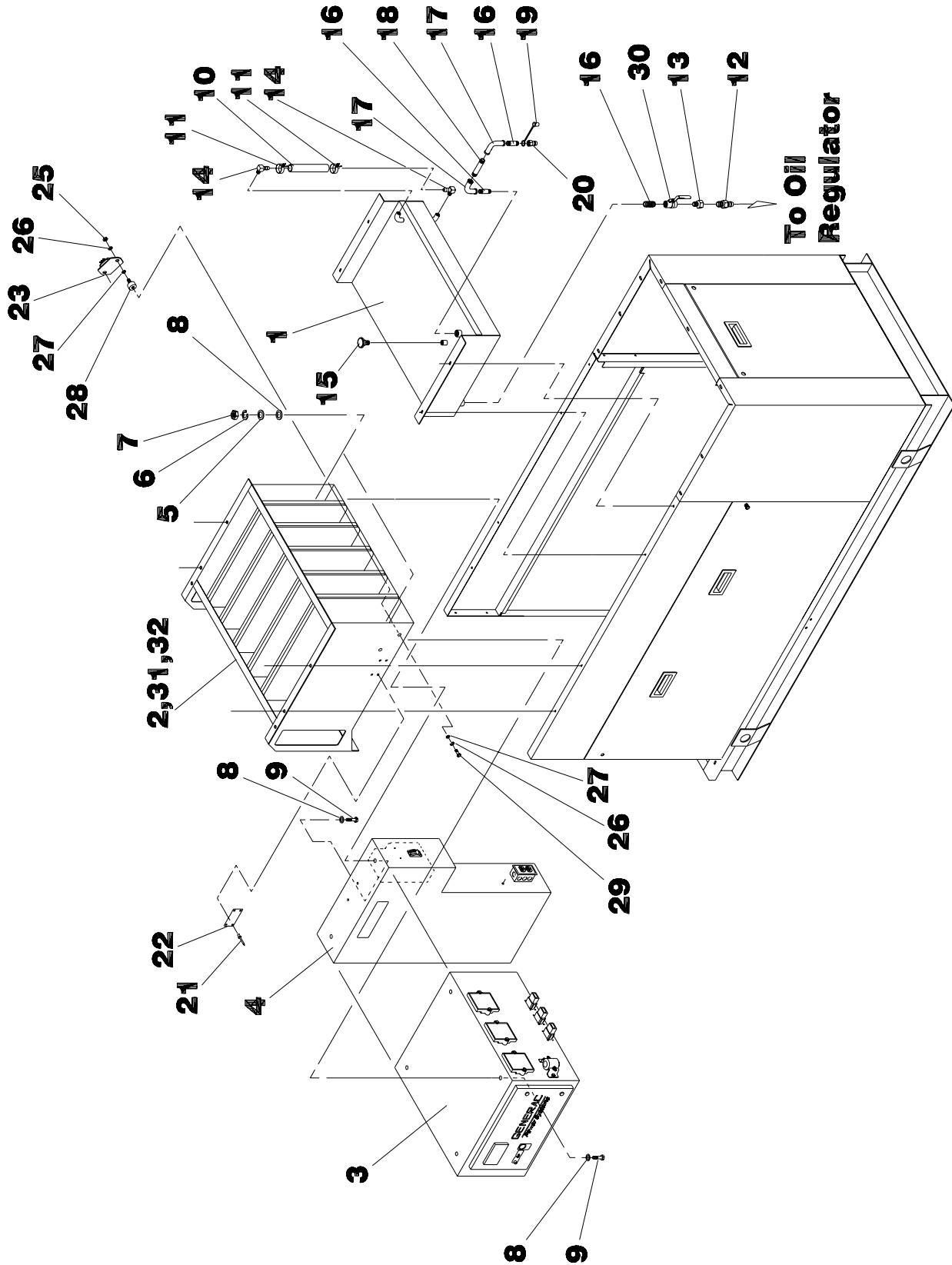

Section 7 – Exploded Views and Parts Lists

DG 50 Generator Set Control Panel & Connection Box – Drawing No. C6462-D

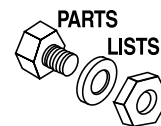

ITEM	PART NO.	QTY.	DESCRIPTION
1	C3751	1	WELDMENT OIL PAN
2	C3630	1	WELDMENT AIR INLET DUCT
3	C5946	1	ASSY BOX F-PANEL
	C9578	1	ASSY C-PANEL 120/208
4	C5334	1	ASSY CONN PANEL 5.7L
	C7359	1	ASSY CONN BOX 208/120
5	22131	6	WASHER FLAT 3/8 ZINC
6	22237	6	WASHER LOCK 3/8
7	22241	6	NUT HEX 3/8-16 STEEL
8	90977	12	WASHER FLAT SPECIAL .375 I.D.
9	31578	6	SCREW HHC 3/8-16 X 1-1/2 G8
10	C7831	4"	TUBE OIL 5/16 ID
11	48031G	2	CLAMP HOSE BAND
12	55596	1	STRAIGHT BRBD 3/8 NPT X 3/8
13	30418	1	BUSHING REDUCER 1/2 TO 3/8
14	59502	2	ELBOW BARB 5/16 X 1/4 X 1.01
15	26847	1	BREATHER
16	30985	3	NIPPLE CLOSE 1/2 X 1.125
17	30419	2	ELBOW 90D 1/2 NPT
18	25429	1	NIPPLE PIPE 1/2 NPT X 4
19	C3158	1	COVER DUST
20	C3159	1	DISCONNECT QUICK 1/2 NPT MALE
21	36261	4	RIVET POP .125 X .129-.133/#30
22	45452S	1	PLATE DATA NAME
23	A2702	1	REGULATOR VOLTAGE (20A.)
24	C7599	1	HARNESS D.C. ALT (NOT SHOWN)
25	22127	2	NUT HEX 1/4-20 STEEL
26	22097	4	WASHER LOCK M6-1/4
27	22473	4	WASHER FLAT 1/4 ZINC
28	40479	2	MOUNT VIBR 1.00 X 1.00 X 1/4-20
29	21394	2	SCREW HHC 1/4-20 X 3/8
30	78944	1	VALVE BALL
31	C3201E	2	INSULATION AIR INLET DUCT SIDE
32	C3201F	5	INSULATION AIR INLET DUCT MIDDLE

Section 7 – Exploded Views and Parts Lists

**DG 50 Generator Set
Carburetor – Drawing No. C7369-C**

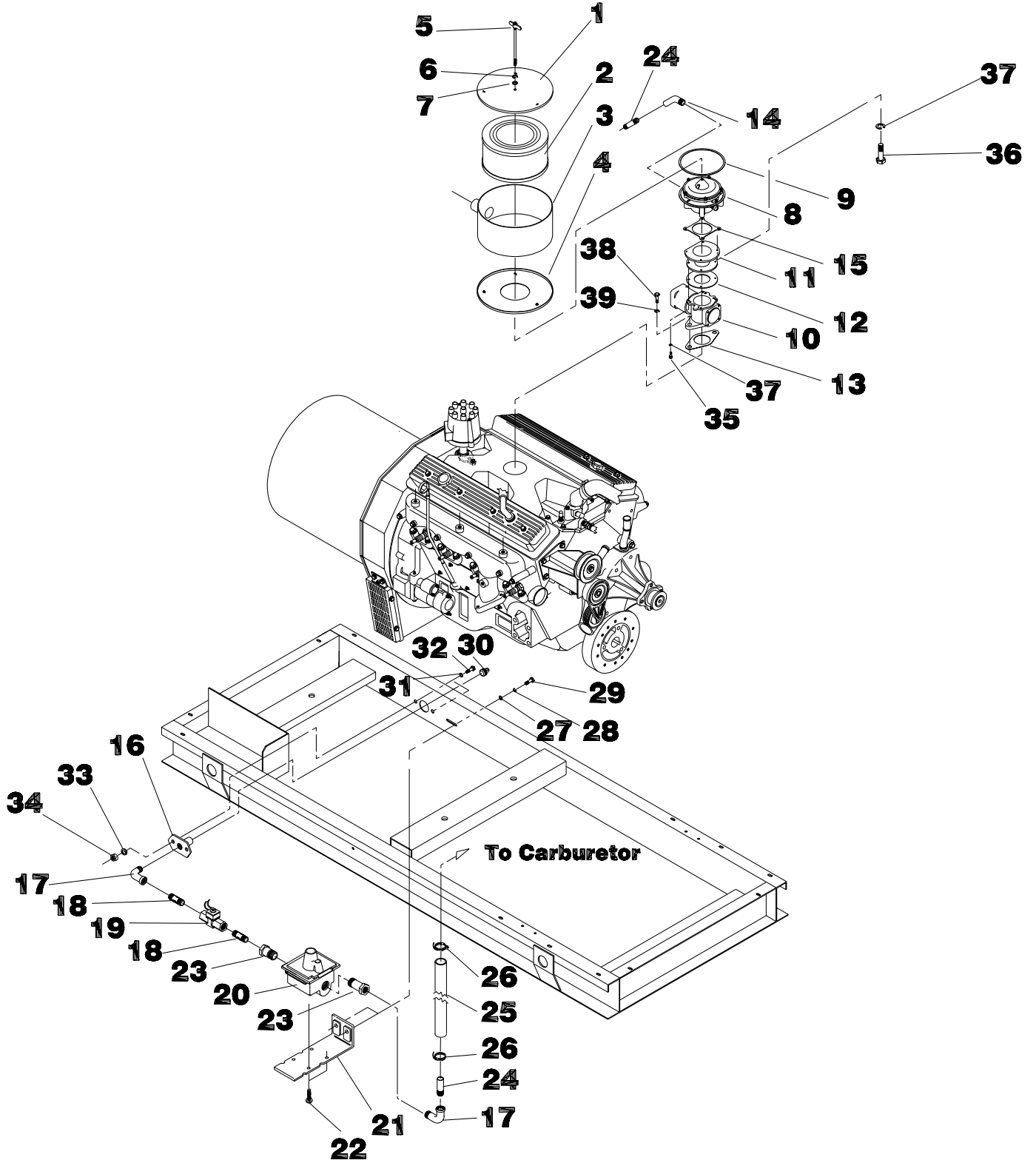

Section 7 – Exploded Views and Parts Lists

DG 50 Generator Set Carburetor – Drawing No. C7369-C

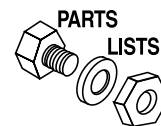

ITEM	PART NO.	QTY.	DESCRIPTION
1	C4236	1	PLATE AIR CLEANER TOP
2	C3197	1	AIR CLEANER, 50KW5.7
3	C4240	1	WELDMENT AIR CLEANER HOUSING
4	C4236A	1	PLATE AIR CLEANER BOTTOM
5	C7366	1	BOLT WING 1/4-20 X 8.5
6	22097	1	WASHER LOCK M6-1/4
7	22473	1	WASHER FLAT 1/4 ZINC
8	C7650	1	MIXER(ONLY)IMPCO225M
9	61258	1	GASKET AIR CLEANER
10	C7858	1	ASSY GOVERNOR
11	C7058	1	ADAPTOR CARBURETOR
12	C7060	1	ADAPTOR GASKET
13	C7059	1	GASKET POWER FLOW
14	25425	1	ELBOW 45D STREET 3/4NPT
15	A6613	1	GASKET CARB
16	65907	1	SUPPORT SOLENOID NAT GAS
17	26307	2	ELBOW 90D STREET 3/4
18	26915	2	NIPPLE CLOSE 3/4X1.375
19	C7598	1	ASSY NATURAL GAS SOLENOID
20	55944	1	REGULATOR NAT GAS LPG VAPOR
21	67018	1	SUPPORT REGULATOR
22	61910	4	SCREW TAPTITE #10-24X3/4 BP
23	26577	2	BUSHING REDUCER 1 TO 3/4
24	28641	2	NIPPLE TOE 3/4NPTX2
25	57422	1	HOSE 1" ID
26	57824	2	CLAMP HOSE #16 .87 - 1.50
27	22145	2	WASHER FLAT 5/16 ZINC
28	22129	2	WASHER LOCK M8-5/16
29	22142	2	SCREW HHC 5/16-18 X 3/4 G5
30	25655	1	PLUG STD PIPE 3/4 STEEL SQ HD
31	22132	2	WASHER FLAT 9/16 ZINC
32	51778	2	SCREW HHC M14-2.0 X 25 G8.8
33	43123	4	WASHER LOCK M14
34	51779	2	NUT HEX M14-2 G8 YEL CHR
35	C7908	4	SCREW SHC #10-32X5/8 G8.8 NZ
36	64090	4	SCREW PHM SEMS #12-24 X 5/8 EX
37	22152	8	WASHER LOCK #10
38	29745	2	SCREW HHC 3/8-16 X 1 G5
39	22237	2	WASHER LOCK 3/8



Section 8 – Warranty

DG 50 Generator Set

GENERAC POWER SYSTEMS STANDARD ONE-YEAR LIMITED WARRANTY FOR “DG 50”

For a period of 1 (one) year or 3,000 (three thousand) hours of operation from the date of original sale, whichever occurs first, Generac Power Systems, Inc. will, at its option, repair or replace any part which, upon examination, inspection and testing by Generac Power Systems or a Generac Power Systems Authorized Warranty Service Facility, is found to be defective under normal use and service, in accordance with the warranty schedule set forth below. Any equipment that the purchaser/owner claims to be defective must be returned to and examined by the nearest Generac Power Systems Authorized Warranty Service Facility. All transportation costs under the warranty, including return to the factory, are to be borne and prepaid by the purchaser/owner. This warranty applies only to Generac Power Systems generators sold as and rated as “DG 50” units as Generac Power Systems, Inc. have defined as “DG 50”. Provided said generator has been initially installed and inspected on-site by a Generac Power Systems Authorized Service Dealer or branch thereof, limited to and available only on liquid-cooled units.

WARRANTY SCHEDULE

YEAR ONE – 100% (one hundred percent) coverage on mileage*, labor and parts listed:

- **Engine** – All components
- **Alternator** – All components
- **Transfer System** – All components

*Travel allowance is limited to 300 miles maximum, or 7.5 hours maximum, round trip, and only applies to permanently wired and mounted units.

All warranty expense allowances **are** subject to the conditions defined in Generac Power Systems *Warranty Policies, Procedures and Flat Rate Manual*.

Units that have been resold **are not** covered under the Generac Power Systems warranty, as this warranty **is not** transferable.

THIS WARRANTY SHALL NOT APPLY TO THE FOLLOWING:

- Costs of normal maintenance, adjustments, installation and start-up.
- Units sold, rated or used for “Standby” applications as Generac Power Systems has defined by Standby. Contact a Generac Power Systems distributor for Standby definition and warranty.
- Failures due, but not limited to, normal wear and tear, accident, misuse, abuse, negligence or improper installation.
- Caused by any external cause or act of God such as collision, fire, theft, freezing, vandalism, riot or wars, lightning, earthquake, windstorm, hail, volcanic eruption, water or flood, tornado, hurricane, or nuclear holocaust.
- Products that are modified or altered in a manner not authorized by Generac Power Systems in writing.
- Any incidental, consequential or indirect damages caused by defects in materials or workmanship, or any delay in repair or replacement of the defective part(s).
- Failure due to misapplication.
- Telephone, telegraph, teletype or other communication expenses.
- Living or travel expenses of person(s) performing service, except as specifically included within the terms of a specific unit warranty period.
- Rental equipment used while warranty repairs are being performed.
- Overtime labor.
- Starting batteries, fuses, light bulbs and engine fluids, overnight freight cost for replacement part(s).

THIS WARRANTY IS IN PLACE OF ALL OTHER WARRANTIES, EXPRESS OR IMPLIED. SPECIFICALLY, GENERAC POWER SYSTEMS MAKES NO OTHER WARRANTIES AS TO MERCHANTABILITY OR FITNESS FOR A PARTICULAR PURPOSE. Some states do not allow limitations on how long an implied warranty lasts, so the above limitation may not apply to you.

GENERAC POWER SYSTEMS ONLY LIABILITY SHALL BE THE REPAIR OR REPLACEMENT OF PART(S) AS STATED ABOVE. IN NO EVENT SHALL GENERAC POWER SYSTEMS BE LIABLE FOR ANY INCIDENTAL, OR CONSEQUENTIAL DAMAGES, EVEN IF SUCH DAMAGES ARE A DIRECT RESULT OF GENERAC POWER SYSTEMS, INC. NEGLIGENCE. Some states do not allow the exclusion or limitation of incidental or consequential damages, so the above limitations may not apply to you. Purchaser/owner agrees to make no claims against Generac Power Systems, Inc. based on negligence.

This warranty gives you specific legal rights. You also may have other rights that vary from state to state.

GENERAC® POWER SYSTEMS, INC.

P.O. BOX 8
WAUKESHA, WI 53187