

GENERAC®

POWER SYSTEMS, INC.

Owner's Manual

DG 50 Genset

**Liquid-cooled, Gas Engine
Generator Set**

Models:

004165-1 (50 kW/208V/Three-phase)

004167-1 (50 kW/480V/Three-phase)

004275-1 (50 kW/208V/Three-phase)

004376-1 (50 kW/480V/Three-phase)

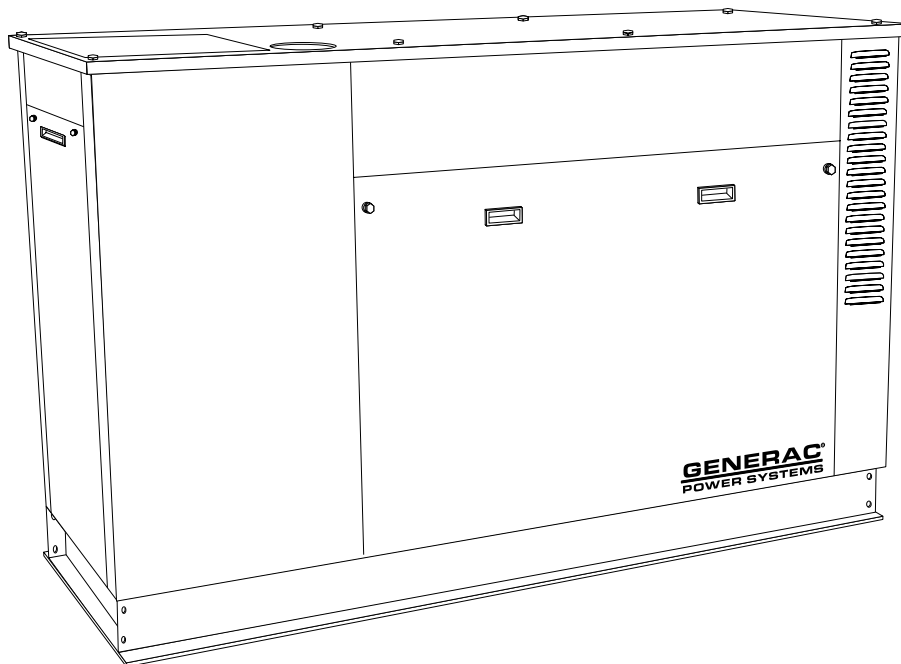

This manual should remain with the unit.

—▲ **DANGER** ▲—

**ONLY QUALIFIED ELECTRICIANS OR CONTRACTORS
SHOULD ATTEMPT INSTALLATION!!**

INTRODUCTION

The DG 50 is a self contained paralleling generator set, capable of supplying 50kW either as a standby generator, or, in parallel with the existing utility supply. This means it can be used to reduce the energy consumption from the utility company (by up to 50kW) when required (Base Loading mode). The unit can be put in parallel from either the front panel, a contact closure or via one of its communication channels.

In conjunction with an optional "PowerManager™", one or many units can be used to automatically reduce peak loading on the utility, thus avoiding the expensive penalties involved. The PowerManager™ can be programmed to operate in many different modes - base load daily, multiple times daily, work days only or, in Peak Shave mode to limit the utility loading to a programmable fixed value. Generator Power Factor can also be controlled from this module.

Both the DG 50 and the PowerManager™ have multiple communication facilities. The stand alone DG 50 can be connected to a modem and communicate to a remote PC using Generac's proprietary software package "GenLink®". The unit can also communicate concurrently with building management systems using the industry standard Modbus protocol. In either case, Engine status and performance monitoring can be done and the unit started (and stopped) in parallel mode.

The PowerManager™ can communicate with multiple generator sets on one site, then in turn, it can communicate this information to both a remote PC (Via modem; US Robotics V90 56K is recommended. See GenLink® manual for proper setup.) and a building management system. In this case the PowerManager™ acts as a relay station between the DG 50's and the communicating devices.

◆ READ THIS MANUAL THOROUGHLY

If you do not understand any portion of this manual, contact Generac or the nearest Generac Authorized Dealer for starting, operating and servicing procedures.

Throughout this publication, and on tags and decals affixed to the generator, DANGER, WARNING, CAUTION and NOTE blocks are used to alert personnel to special instruction about a particular operation that may be hazardous if performed incorrectly or carelessly. Observe them carefully. Their definitions are as follows:



After this heading are instructions that, if not strictly complied with, will result in personal injury or property damage.



After this heading are instructions that, if not strictly complied with, may result in personal injury or property damage.



After this heading are instructions that, if not strictly complied with, could result in damage to equipment and/or property.

NOTE:

After this heading are explanatory statements that require special emphasis.

Generac® Power Systems, Inc.

These safety warnings cannot eliminate the hazards that they indicate. Common sense and strict compliance with the special instructions while performing the service are essential to preventing accidents.

Four commonly used safety symbols accompany the DANGER, WARNING and CAUTION blocks. The type of information each indicates is as follows:

 **This symbol points out important safety information that, if not followed, could endanger personal safety and/or property or others.**

 **This symbol points out potential explosion hazard.**

 **This symbol points out potential fire hazard.**

 **This symbol points out potential electrical shock hazard.**

The operator is responsible for proper and safe use of the equipment. Generac strongly recommends that the operator read this *Owner's Manual* and thoroughly understand all instructions before using this equipment. Generac also strongly recommends instructing other users to properly start and operate the unit. This prepares them if they need to operate the equipment in an emergency.

◆ CONTENTS

This manual contains pertinent owner's information, including warranty, electrical diagrams, exploded views and lists of repair parts, for the following models: 004165-1, 004167-1, 004275-1 and 004376-1

◆ OPERATION AND MAINTENANCE

It is the operator's responsibility to perform all safety checks, to make sure that all maintenance for safe operation is performed promptly, and to have the equipment checked periodically by a Generac Authorized Dealer. Normal maintenance service and replacement of maintenance parts are the responsibility of the owner/operator and, as such, are not considered defects in materials or workmanship within the terms of the warranty. Individual operating habits and usage contribute to the need for maintenance service.

Proper maintenance and care of the generator ensures a minimum number of problems and keep operating expenses at a minimum. See a Generac Authorized Dealer for service aids and accessories.

◆ HOW TO OBTAIN SERVICE

When the generator requires servicing or repairs, contact a Generac Authorized Dealer for assistance. Service technicians are factory-trained and are capable of handling all servicing needs.

When contacting a Generac Authorized Dealer or the factory about parts and service, always supply the complete model number and serial number of the unit as given on its data decal, which is located on the generator.

Model No. _____ Serial No. _____

AUTHORIZED DEALER LOCATION

To locate the nearest GENERAC AUTHORIZED DEALER, please call:

1-800-333-1322

or visit our website at:
www.GENERAC.com

Introduction.....Inside Front Cover	
Read This Manual Thoroughly	IFC
Contents	IFC
Operation and Maintenance	IFC
How to Obtain Service	IFC
Authorized Dealer Locator Number	IFC
Safety Rules.....2	
Section 1 – General Information4	
1.1 Unpacking/Inspection	4
1.1.1 Lifting the Generator	4
1.2 Installation Information	4
1.3 Customer Terminal Block Connections	4
1.4 Specifications	5
1.4.1 Generator	5
1.4.2 Engine	5
1.4.3 Ambient Temperature Limits	5
1.5 Fuel Requirements and Recommendations.....	5
1.6 Engine Oil Requirements	5
1.7 The Battery.....	5
1.8 The AVR Power Module	6
1.9 The Throttle Actuator Module	6
1.10 The Overspeed Module.....	6
1.11 The Watchdog Module	7
1.12 The Battery Charger	7
1.13 The Exerciser Module.....	7
1.14 Emissions System	7
Section 2 – Operation.....8	
2.1 Control Console Components.....	8
2.1.1 Off	8
2.1.2 Manual.....	8
2.1.3 Automatic.....	8
2.2 Keypad	8
2.3 Display	8
2.3.1 Software Version Screen	9
2.3.2 Generator Command Screen	9
2.3.3 Generator Status Screen	9
2.3.4 Alarm Status Message Screen	9
2.3.5 Instrumentation Screen	9
2.3.6 Parameter Entry Screen.....	9
2.3.7 Alarm Log Screen.....	11
2.4 Alarms	11
2.4.1 Alarm Types	11
2.4.2 Activity Settings	12
2.5 Responding to Alarms	12
2.5.1 Accepting an Alarm.....	12
2.5.2 Clearing an Alarm.....	12
2.6 Alarm Type	12
2.6.1 Common Alarm Relay	12
2.6.2 Warning — Non-Latched.....	12
2.6.3 Alarm — Latched	12
2.6.4 Shutdown	12
2.7 Programmable Parameters	12
2.7.1 Preheat Enabled.....	12
2.7.2 Preheat Time	13
2.7.3 Exercise Options	13
2.7.4 User Password	13
2.7.5 Panel ID	13
2.7.6 Restore Defaults.....	13
2.7.7 Running Hours.....	13
2.7.8 Flywheel Teeth	13
2.7.9 Starter Disengage Speed	13
2.7.10 Number of Start Attempts	13
2.7.11 Start Timer	13
2.7.12 Start Attempt Pause Time	13
2.7.13 Cool Down Time	13
2.7.14 Warm Up Time.....	13
2.7.15 Alarm Hold Off Time	13
2.8 Programmable AVR Parameters	14
2.8.1 Power Output Setpoint Source.....	14
2.8.2 Generator Voltage Calibration	14
2.8.3 Utility Voltage Calibration.....	14
2.8.4 Power Factor	14
2.8.5 Power Output Setpoint.....	14
2.9 Governor Parameters	14
2.9.1 Gain	14
2.9.2 Stability	14
2.9.3 Differential	14
2.10 Droop Gain.....	14
2.11 Droop Select.....	14
2.12 Under Frequency Slope	14
2.13 Under Frequency Corner	14
2.14 Voltage Stability and Gain.....	14
2.14.1 Stability	15
2.14.2 Gain	15
2.15 Frequency Setpoint.....	15
2.16 AC Voltage Setpoint	15
2.17 Programmable Alarm Setpoints	15
2.17.1 Oil Pressure Alarms	15
2.17.2 Oil Temperature Alarms.....	15
2.17.3 Coolant Temperature Alarms	16
2.17.4 Battery Voltage Alarms	16
2.17.5 Engine Speed Alarms	16
2.17.6 Generator Voltage Alarms	16
2.17.7 Generator Frequency Alarms	16
2.17.8 Fuel Level Alarms.....	16
2.17.9 Overcrank Alarms	16
2.17.10 Coolant Level Alarm	16
2.17.11 Transfer Error Alarms	16
2.17.12 Internal Communication Alarm	16
2.18 Parallel Operation.....	16
2.18.1 Setting Up	17
2.18.2 Remote Parallel Operation (GenLink®).....	17
2.18.3 Parallel Errors	17
2.18.4 Loss of Utility in Parallel	17
2.19 Serial Communications	17
2.19.1 GenLink®	17
2.19.2 Remote Annunciator-Relay Panels	17
2.19.3 Building Management	17
2.19.4 Method of Connection	18
2.20 Additional Standard Components	18
2.20.1 Line Phase Selector Switch	18
2.20.2 AC Voltmeter	18
2.20.3 AC Ammeter.....	18
2.20.4 DC Panel Fuse	18
2.20.5 Emergency Stop Switch	18
2.20.6 Parallel Switch	18
2.21 The Transfer Switch.....	19
2.22 The Checksynch board	19
2.23 Relay Protection Scheme	20
Section 3 – Maintenance.....21	
3.1 Checking the Engine Oil Level	21
3.2 Changing the Engine Oil and Filter	21
3.2.1 Engine Oil Requirements	21
3.2.2 Oil and Filter Change Procedure	21
3.3 Oil Lubrication System Components	22
3.4 Changing the Engine Air Cleaner	23
3.5 Spark Plugs	23
3.6 Battery Maintenance.....	23
3.7 Cooling System.....	23
3.7.1 Engine Heater	24
3.8 Overload Protection for Engine DC Electrical System ..	24
3.8.1 Fuse	24
3.9 Engine Coolant	24
3.10 Miscellaneous Maintenance	24
3.10.1 Cleaning the Generator	24
3.10.2 Cleaning the Radiator.....	25
3.10.3 Rodent Protection.....	25
3.11 Out of Service Procedure	25
3.11.1 Removal From Service	25
3.12 Service Schedule	26
Section 4 – Troubleshooting.....27	
4.1 Troubleshooting Guide.....	27
Section 5 – Notes	28
Appendix 1 – Standard Configurations	29
Appendix 2 – F Panel Operations Display Map.....	30
Section 6 – Electrical Data	32
Section 7 – Exploded Views and Parts Lists.....	39
Section 8 – Warranty	Back Cover



⚠️ SAVE THESE INSTRUCTIONS – This manual contains important instructions that should be followed during installation and maintenance of the generator and batteries. The manufacturer suggests that these rules for safe operation be copied and posted in potential hazard areas. Safety should be stressed to all operators and potential operators of this equipment. ⚠️

⚠️ DANGER ⚠️

⚠️ Utility voltage is present within the control cabinets of this unit. Unit should only be serviced by authorized personnel.

⚠️ WARNING: ⚠️
The engine exhaust from this product contains chemicals known to the state of California to cause cancer, birth defects or other reproductive harm.

⚠️ WARNING: ⚠️
This product contains or emits chemicals known to the state of California to cause cancer, birth defects or other reproductive harm.

Study these SAFETY RULES carefully before installing, operating or servicing this equipment. Become familiar with this *Owner's Manual* and with the unit. The generator can operate safely, efficiently and reliably only if it is properly installed, operated and maintained. Many accidents are caused by failing to follow simple and fundamental rules or precautions.

Generac cannot possibly anticipate every possible circumstance that might involve a hazard. The warnings in this manual, and on tags and decals affixed to the unit are, therefore, not all-inclusive. If using a procedure, work method or operating technique Generac does not specifically recommend, you must satisfy yourself that it is safe for you and others. Also make sure the procedure, work method or operating technique chosen does not render the generator unsafe.

⚠️ DANGER ⚠️

⚠️ Despite the safe design of this generator, operating this equipment imprudently, neglecting its maintenance or being careless can cause possible injury or death. Permit only responsible and capable persons to operate or maintain this equipment.

⚠️ Potentially lethal voltages are generated by these machines. Ensure all steps are taken to render the machine safe before attempting to work on the generator.

⚠️ Parts of the generator are rotating and/or hot during operation. Exercise care near running generators.

⚠️ GENERAL HAZARDS ⚠️

- For safety reasons, Generac requires that the installation, initial start-up and maintenance of this equipment is carried out by a Generac Authorized Dealer.
- The engine exhaust fumes contain carbon monoxide, which can be DEADLY. This dangerous gas, if breathed in sufficient concentrations, can cause unconsciousness or even death. This exhaust system must be installed properly, in strict compliance with applicable codes and standards. Following installation, do nothing that might render the system unsafe or in noncompliance with such codes and standards.
- Keep hands, feet, clothing, etc., away from drive belts, fans, and other moving or hot parts. Never operate the unit with any drive belt or fan guard removed.
- Adequate, unobstructed flow of cooling and ventilating air is critical to correct generator operation. Do not alter the installation or permit even partial blockage of ventilation provisions, as this can seriously affect safe operation of the generator.
- When working on this equipment, remain alert at all times. Never work on the equipment when physically or mentally fatigued.
- Inspect the generator regularly, and repair or replace all damaged or defective parts immediately. Always use factory-authorized parts.
- Turn off the AC power to the battery charger before disconnecting the battery to minimize the chance of equipment damage.
- Before performing any maintenance on the generator, disconnect its battery cables to prevent accidental start-up. Disconnect the cable from the battery post indicated by a NEGATIVE, NEG or (–) first. Reconnect that cable last.
- Never use the generator or any of its parts as a step. Stepping on the unit can stress and break parts, and may result in dangerous operating conditions from leaking exhaust gases, fuel leakage, oil leakage, etc.



 ELECTRICAL HAZARDS 

- All generators covered by this manual produce dangerous electrical voltages and can cause fatal electrical shock. Utility power delivers extremely high and dangerous voltages to the transfer switch as does the standby generator when it is in operation. Avoid contact with bare wires, terminals, connections, etc., while the unit is running. Ensure all appropriate covers, guards and barriers are in place before operating the generator. If working around an operating unit, stand on an insulated, dry surface to reduce shock hazard.
- Do not handle any kind of electrical device while standing in water, while barefoot, or while hands or feet are wet. **DANGEROUS ELECTRICAL SHOCK MAY RESULT.**
- The National Electrical Code (NEC) requires the frame and external electrically conductive parts of the generator to be connected to an approved earth ground. Local electrical codes also may require proper grounding of the generator electrical system.
- After installing this standby electrical system, the generator may crank and start at any time without warning. When this occurs, load circuits are transferred to the STANDBY (generator) power source. To prevent possible injury if such a start and transfer occur, always set the generator's Auto/Off/Manual switch to its OFF position before working on equipment and remove the 15A fuse in front panel.
- In case of accident caused by electric shock, immediately shut down the source of electrical power. If this is not possible, attempt to free the victim from the live conductor. **AVOID DIRECT CONTACT WITH THE VICTIM.** Use a nonconducting implement, such as a rope or board, to free the victim from the live conductor. If the victim is unconscious, apply first aid and get immediate medical help.
- Never wear jewelry when working on this equipment. Jewelry can conduct electricity resulting in electric shock, or may get caught in moving components causing injury.
- The enclosure panels on the DG 50 are grounded to the chassis with wires using quick disconnect connectors. These grounding wires must be reconnected when the panels are replaced to reduce the risk of electric shock.

 FIRE HAZARDS 

- For fire safety, the generator must be installed and maintained properly. Installation always must comply with applicable codes, standards, laws and regulations. Adhere strictly to local, state and national electrical and building codes. Comply with regulations the Occupational Safety and Health Administration (OSHA) has established. Also, ensure that the generator is installed in accordance with the manufacturer's instructions and recommendations. Following proper installation, do nothing that might alter a safe installation and render the unit in noncompliance with the aforementioned codes, standards, laws and regulations.
- Keep a fire extinguisher near the generator at all times. Extinguishers rated "ABC" by the National Fire Protection Association are appropriate for use on the standby electric system. Keep the extinguisher properly charged and be familiar with its use. If there are any questions pertaining to fire extinguishers, consult the local fire department.

 EXPLOSION HAZARDS 

- Do not smoke around the generator. Wipe up any fuel or oil spills immediately. Ensure that no combustible materials are left in the generator compartment, or on or near the generator, as FIRE or EXPLOSION may result. Keep the area surrounding the generator clean and free from debris.
- Gaseous fluids such as natural gas are extremely EXPLOSIVE. Install the fuel supply system according to applicable fuel-gas codes. Before placing the standby electric system into service, fuel system lines must be properly purged and leak tested according to applicable code. After installation, inspect the fuel system periodically for leaks. No leakage is permitted.

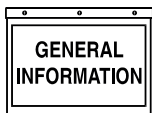

11.1 UNPACKING/INSPECTION

After unpacking, carefully inspect the contents for damage.

- This standby generator set has been factory installed in an all-weather, metal enclosure that is intended exclusively for outdoor installation.

If any loss or damage is noted at time of delivery, have the person(s) making the delivery note all damage on the freight bill or affix their signature under the consignor's memo of loss or damage. Cosignee is responsible to claim any shipping loss or damage with the shipper.

If there is loss or damage after delivery, separate the damaged materials and contact the carrier for claim procedures.

“Concealed damage” is understood to mean damage to the contents of a package that is not in evidence at the time of delivery, but is discovered later.

◆ 1.1.1 LIFTING THE GENERATOR



When lifting or hoisting equipment is used, be careful not to touch overhead power lines.

The generator's weight of more than 2,000 pounds requires proper tools and equipment, and qualified personnel to be used in all phases of handling and unpacking.

1.2 INSTALLATION INFORMATION

This unit has an open bottom and must be installed over non-combustible materials such that combustible materials do not accumulate underneath it.

This genset must be installed on a level surface. The base frame must be level within 1/2 inch all around.

Connect the grounding lug to a code-compliant building ground system.

The three-phase alternator is shipped from the factory with the stator output leads connected either parallel wye (for 120/208V) or series wye (for 277/480V).

This unit must be installed so that air cannot recirculate under the radiator back into the engine area. This will ensure maximum cooling system performance.

Other important information and installation guidelines are found in the Installer's Guide and Reference Manual, part number 046622.

1.3 CUSTOMER TERMINAL BLOCK CONNECTIONS

There are two terminal blocks for customer connections. One terminal block is located inside the transfer switch enclosure immediately beneath the transfer switch (TS1). DO NOT ENTER THIS ENCLOSURE WITH UTILITY VOLTAGE PRESENT OR WITH BATTERY POWER ON THE GENERATOR. Terminal one (1) is at the left hand end of the terminal block. The following user connections can be made to this terminal block for 120V AC utility for the jacket water heater and battery charger:

- Terminal 14 - Earth
- Terminal 15 - Neutral
- Terminal 16 - Live

The second terminal block is located on the left wall of the same enclosure (TS3) with terminal 1 located at the bottom. The following user connections can be made to this terminal block:

- Terminal 1 - Positive battery (fused)
- Terminal 2,3 - Remote emergency stop switch (normally closed contact).
- Terminal 4,5 - Remote parallel switch (normally open contact). This duplicates the front panel parallel switch, the generator can be started and go into parallel from either switch.
- Terminal 6,7 - Remote Island switch (normally open contact). This duplicates the front panel island mode switch. The unit can be started and go into island mode from either switch.
- Terminal 8 - RS485 — (minus) communications port connection.
- Terminal 9 - RS485 + (plus) communications port connection. Use twisted pair shielded cable for this connection with the shield going to terminal 10 (earth). This is for connecting to the PowerManager™, remote annunciator/relay panel or GenLink®. See “Serial Connection - Method of Connection” (section 2.20.4).
- Terminal 10 - RS232 common communications port connection.
- Terminal 11 - RS232 tx communications port connection.
- Terminal 12 - RS232 rx communications port connection. Use three core shielded cable for this connection with the shield going to terminal 4 (earth). This is for connecting to the remote annunciator/relay panel or GenLink®. See “Serial Connection - Method of Connection” (section 2.20.4).

1.4 SPECIFICATIONS

◆ 1.4.1 GENERATOR

Models	004165-1/004167-1/004275-1/004376-1
Rated Maximum Continuous AC Power Output (kW)*	50
Rated Voltage (volts)	208 or 480
Rated Maximum Continuous Current at	
208 Volts, Three-phase (amps)	173
480 Volts, Three-phase (amps)	75
Number of Rotor Poles	4
Driven Speed of Rotor (rpm)	1,800
Type of Stator	12-wire Reconnectable
Rotor Excitation System	Brushless
Rotor and Stator Insulation	Class "H"

*Rated power of generator is subject to and limited by such factors as ambient temperature, altitude, engine condition and other factors. Engine power will decrease about 3.5 percent for each 1,000 feet above sea level; and also will decrease an additional 1 percent for each 12° C (10° F) above 15.5° C (60° F). Maximum output power of the generator is limited by maximum engine power.

◆ 1.4.2 ENGINE

Make	Generac
Displacement	5.7 liters (350 cu. in.)
Cylinder Arrangement	V-8
Bore	4.0 in. (101.6 mm)
Stroke	3.48 in. (88.4 mm)
Firing Order	1-8-4-3-6-5-7-2
Number of Main Bearings	5
Compression Ratio	9.4-to-1
No. of Teeth on Flywheel	168
Intake Air	Naturally Aspirated
Connecting Rods	Steel
Cylinder Head	Cast Iron
Pistons	Aluminum Alloy
Crankshaft	Iron
Ignition System	Electronic
Ignition Timing at 1,800 rpm	35 degrees BTDC
Engine Rated Horsepower at 1,800 rpm (Gross)	74
Spark Plug Gap	0.035 inch (.89 mm)
Recommended Spark Plugs	A/C Delco
Oil Pressure	50 psi
Total Oil Capacity	45 U.S. quarts (42.58 L)
Required Engine Oil	Shell Mysella Ashless 15W-40
Type of Cooling System	Pressurized, closed recovery
Cooling Fan	Puller Type
Cooling System Capacity	5.5 U.S. gallons (20.8 L)
Recommended Coolant	Use a 50-50 mixture of ethylene glycol and de-ionized water.

Fuel Consumption

Natural Gas

004165-1/004167-1/004275-1/004376-1	850 cfh
---	---------

NOTE:

Fuel consumption is given at rated maximum continuous power output when using natural gas rated at 1,000 Btu per cubic foot. Actual fuel consumption obtained may vary depending on such variables as applied load, ambient temperature, engine conditions and other environmental factors.

◆ 1.4.3 AMBIENT TEMPERATURE LIMITS

-22° F to +110° F (-30° C to +43° C)

1.5 FUEL REQUIREMENTS AND RECOMMENDATIONS

Recommended fuels should have a Btu content of at least 1,000 Btus per cubic foot for natural gas. Ask the local fuel supplier for the Btu content of the fuel.

Fuel pressure for natural gas is 11 inches to 14 inches of water column (0.6 psi) at all load ranges. If fuel pressure falls below these specifications, the emissions control system may not function properly. Periodically check fuel inlet pressure to ensure proper operation.

⚠ WARNING ⚠

⚠ **Gaseous fuels such as natural gas are highly explosive. Even the slightest spark can ignite such fuels and cause an explosion. No leakage of fuel is permitted. Natural gas, which is lighter than air, tends to collect in high areas; LP gas is heavier than air and tends to settle in low areas – install and use leak detectors accordingly.**

1.6 ENGINE OIL REQUIREMENTS

Generac requires the DG 50 to be serviced using Shell Mysella Ashless 15W-40 engine oil. Use of any other oil will invalidate lubrication-related warranty claims.

⚠ CAUTION ⚠

⚠ **Any attempt to crank or start the engine before it has been properly serviced with the required oil may result in an engine failure.**

1.7 THE BATTERY

Use a 12-volt, automotive-type storage battery (Group 3ET) capable of a minimum of 460 cold-cranking amps at -18° C (0° F). Check the specific gravity and electrolyte levels at the intervals specified in the service schedule (Section 3.12). When using maintenance free batteries these procedures are not necessary. A negative ground system is used. Battery connections are shown on the wiring diagrams. Make sure the battery is correctly connected and terminals are tight. Observe battery polarity when connecting the battery to the generator set.

NOTE:

Disconnect the cable from the negative (-) terminal first. Reconnect the negative (-) terminal last. Damage may result if the battery connections are made in reverse.

The generator is equipped with a battery trickle charger that is active when the unit is set up for automatic operation. The trickle charge is designed to help extend the life of the battery by maintaining the battery when the unit is not running.

—▲ CAUTION ▲—

▲ The electrolyte is a dilute sulphuric acid that is harmful to the skin and eyes. It is electrically conductive and corrosive. The following procedures are to be observed:

- Wear full eye protection and protective clothing
- Where electrolyte contacts the skin, wash it off immediately with water
- Where electrolyte contacts the eyes, flush immediately and thoroughly with water and seek medical attention
- Spilled electrolyte is to be washed down with an acid neutralizing agent. A common practice is to use a solution of one pound (500 grams) bicarbonate of soda to one gallon (4 liters) of water. The bicarbonate of soda solution is to be added until the evidence of reaction (foaming) has ceased. The resulting liquid is to be flushed with water and the area dried.

▲ Lead acid batteries present a risk of fire because they generate hydrogen gas. The following procedures must be followed:

- DO NOT SMOKE when near batteries.
- DO NOT cause flame or spark in the battery area.
- Discharge static electricity from the body before touching batteries by first touching a grounded metal surface.

▲ Battery electrolyte fluid is an extremely caustic sulfuric acid solution that can cause severe burns. Do not permit fluid to contact eyes, skin, clothing, painted surfaces, etc. Wear protective goggles, protective clothing and gloves when handling a battery. If fluid is spilled, flush the affected area immediately with clear water.

—▲ WARNING ▲—

▲ Do not dispose of the battery in a fire. The battery is capable of exploding.

▲ Do not open or mutilate the battery. Released electrolyte can be toxic and harmful to the skin and eyes.

▲ The battery represents a risk of electric shock and high short circuit current. When working on the battery, always remove watches, rings or other metal objects, and only use tools that have insulated handles.

1.8 THE AVR POWER MODULE

This module is located on the outside of the control box, on the left, if looking from the battery side of the DG 50 (ten wires total).

The AVR Power Module houses the power electronics that drive the field of the alternator. The actual field control is done in the F panel and the signals are converted to power levels by this unit. It controls the output voltage and voltage stability of the generator. Stability and dynamic response can be adjusted via the front panel keyboard and display. (Dynamic response means how well the module responds to rapidly changing loads).

1.9 THE THROTTLE ACTUATOR MODULE

This module is located on the outside of the control box, in the middle, if looking from the battery side of the DG50 (five wires total).

The Throttle Actuator Module houses the power electronics that drive the actuator module. The actual control is done inside of the F panel and the signals are converted to power levels by this unit. The module operates the throttle for the engine and controls the engine speed and stability. Stability and dynamic response can be adjusted via the front panel keyboard and display. The engine speed is controlled at 60Hz output, but this can be altered to 50Hz (or other speed) via the front panel.

1.10 THE OVERSPEED MODULE

The Overspeed module is located on the rear of the control panel door, to the right of the exerciser. It can be identified by the relay on the board. Access is gained via a special cabinet key. HIGH VOLTAGES ARE PRESENT IN THIS CABINET. Observe the safety rules.

The Overspeed module provides a secondary check on the engine speed. Normally, the F panel will stop the engine (by cutting the fuel) if it overspeeds. If the F panel fails to stop the engine for whatever reason, the overspeed module will stop the engine if it reaches 2550 RPM.

1.11 THE WATCHDOG MODULE

The Watchdog module is located on the rear of the control panel door, to the right and below the exerciser. It can be identified by the Green LED on the board. Access is gained via a special cabinet key. HIGH VOLTAGES ARE PRESENT IN THIS CABINET. OBSERVE THE SAFETY RULES.

The watchdog module is present to keep an eye on the F panel. If it fails, it will stop the engine or prevent it from starting via the emergency stop circuit. The display, if still operable, will show - "Emergency Stop".

1.12 THE BATTERY CHARGER

This module is located on the outside of the control box, on the right, if looking from the battery side of the DG 50 (four wires total).

It is capable of supplying up to 2.5A into the battery. It is powered from a 120 VAC standard utility supply, which has to be wired into the generator on the customer terminal block connections.

1.13 THE EXERCISER MODULE

The Exerciser module is located on the rear of the control panel door. It can be identified by the clock display.

Access is gained via a special cabinet key. HIGH VOLTAGES ARE PRESENT IN THIS CABINET. Observe the safety rules.

1.14 EMISSIONS SYSTEM

The DG 50, when equipped for ultra-low emissions, includes a catalytic muffler and active air/fuel ratio controller (Figure 1.1). This system consists of an oxygen sensor in the exhaust pipe, a microprocessor controller, an air control solenoid and necessary vacuum lines and wiring. The system is self-contained and does not normally need any maintenance or adjustment. The air/fuel ratio controller continuously monitors the exhaust stream and adjusts the air/fuel ratio to maintain the lowest possible emissions.

The catalytic muffler has a test port just before the catalyst so that it can readily be checked for performance. Normally, the catalyst does not need any maintenance. However, if the engine emissions are excessively high and/or contain engine lubrication oil, the catalyst may become ineffective. Engine misfire is also harmful and will damage the catalyst. All engine problems must be promptly corrected to attain long catalyst life.

Figure 1.1 — Emissions System

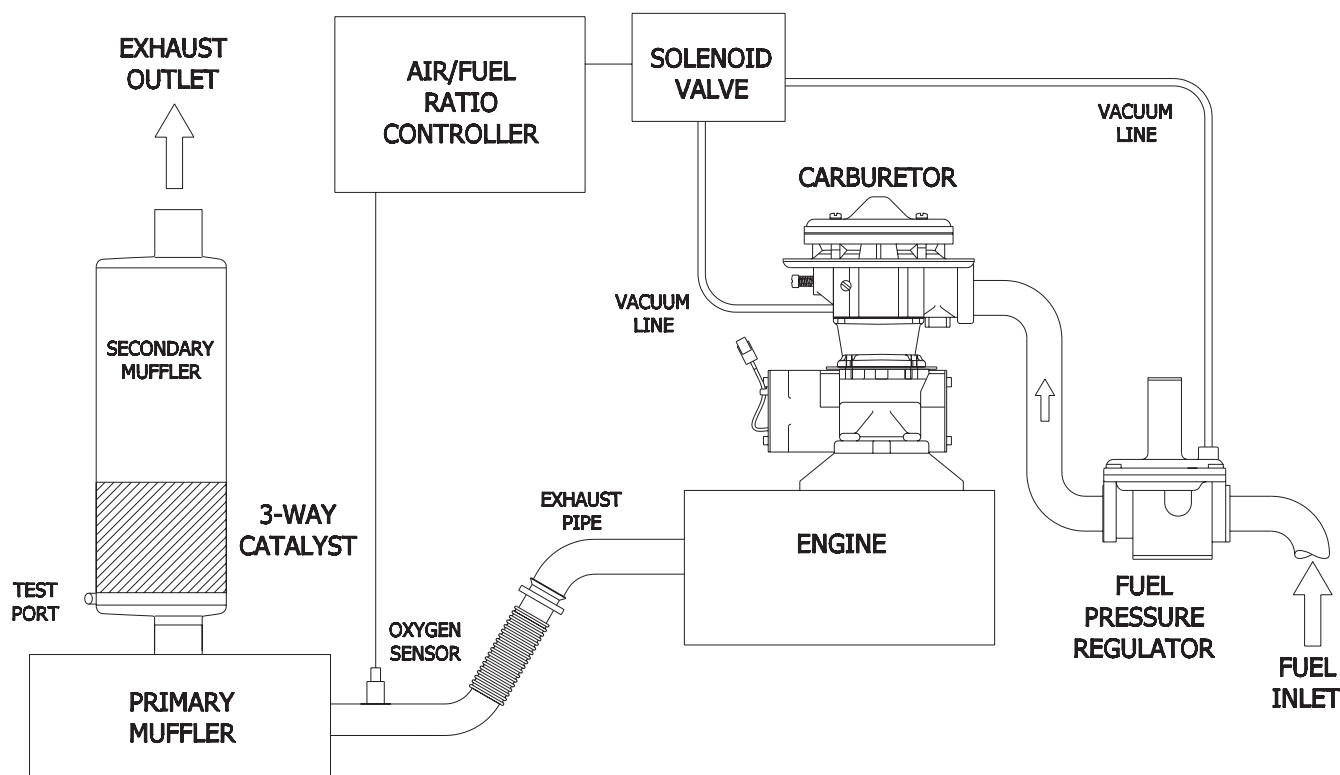

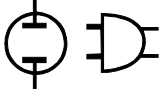

2.1 CONTROL CONSOLE COMPONENTS

The F panel control module performs all of the control functions within the DG 50. It controls engine starting and stopping, engine speed, output voltage and frequency, monitors engine performance, and decides when to operate the transfer switch. It can communicate with remote devices via communication ports. See Figures 2.1 and 2.2.

Figure 2.1 — Location of Control Console

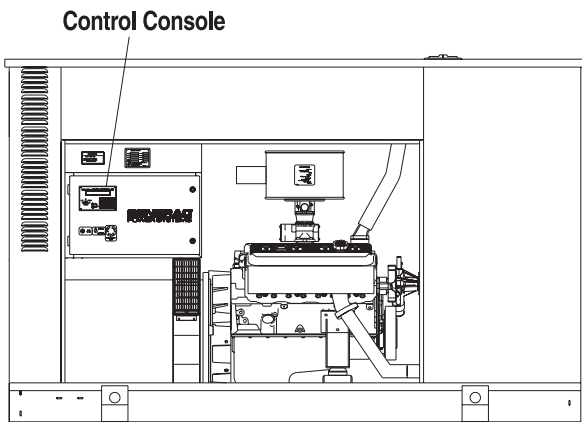

The front panel of the unit acts as the interface to the user. By means of a backlit 24 character LCD and a six key keypad, the user can examine data monitored by the unit and change parameters within the unit. In conjunction with the Emergency Stop switch and the Parallel switch, the key switch can be used to start and stop the genset. The key switch allows the unit to be put into one of three modes.

◆ 2.1.1 OFF

In this mode, the generator will not start.

◆ 2.1.2 MANUAL

In manual mode, the generator will start immediately without altering the state of the transfer switch. If utility power fails while in manual mode, the breakers will not open. This prevents deadbus/checksynch problems. Manual mode is for limited testing of the unit.

◆ 2.1.3 AUTOMATIC

In automatic mode, as the name suggests, the generator will start automatically when power from the utility supply fails. The generator can also be put into parallel mode or island mode via the front panel toggle switch, remote contacts, or via the communication channels. Automatic is the normal mode of operation.

REFER TO THE "F PANEL OPERATIONS FLOW-CHART" (page 10) for details about what the panel will do when power from the utility supply fails in each of the above key switch positions.

Figure 2.2 — Control Console

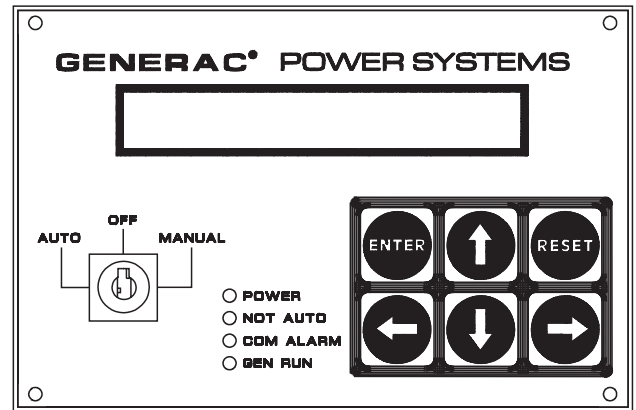

2.2 KEYPAD

The keypad consists of six keys labeled as follows: ↑ (Up), ↓ (Down), ← (Left), → (Right), Enter and Reset.

The left and right arrow keys are used to select the different pages on the display. The up and down arrow keys are used to scroll between options within a page. They are also used for selecting options when the user enters parameters into the unit. The enter key takes the user into a page on the display to change data (when applicable) and also accepts data that has been entered. It is also used to accept an alarm. The reset key ignores data that has been entered and returns the original value. It is also used to return from the parameter entry mode once the user has finished changing the data, and to reset any latched alarms that have been cleared.

2.3 DISPLAY

The display is organized into a series of screens, each screen displays information about the status of the generator. For example, the "Alarm Status Message Screen" displays the highest priority current alarm or status condition. The user will be able to scroll between the screens using the left and right arrow keys. Certain actions also cause the display to change screens (e.g. when an alarm becomes active, the display automatically will go to the alarm status screen and display the alarm message).

The back light for the display is normally off. If the user presses any key, the back light will come on automatically and remain on for five minutes after the last key was pressed. It will also flash if any alarm is active.

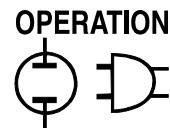

When the display is showing certain screens, the user is able to scroll between relevant items within the screen using the up/down arrow keys. For example, if the display is showing the alarm status screen, the user can scroll between the current alarms with the up/down arrow keys.

A description of each screen is given below.

◆ 2.3.1 SOFTWARE VERSION SCREEN

This screen displays the software revision. Pressing the enter key in this screen will perform a display and LED test.

◆ 2.3.2 GENERATOR COMMAND SCREEN

This screen displays the command sent to the generator. The possible commands are as follows:

- Generator switched off
- Generator in manual mode
- Generator in auto mode - stop command
- Generator in auto mode - remote run command
- Generator in auto mode - serial link run command

◆ 2.3.3 GENERATOR STATUS SCREEN

This screen displays the current status of the generator. Options will be as follows:

- Stopped - ready to run
- Stopped - start inhibit active
- Pre-heating (with timer counting down)
- Attempting to start (with timer counting down and number of attempts)
- Pausing before start attempt (with timer counting down and number of attempts)
- Started - running up to speed
- Warming up
- Ready to accept load
- All alarms enabled
- Cooling down
- Stopping
- Stopped due to alarm

If the user has not pressed a key for some time, any change in status will cause this screen to be displayed provided that there are no active alarms or status messages from other inputs. If an alarm condition occurs, the alarm status screen will be displayed automatically.

◆ 2.3.4 ALARM STATUS MESSAGE SCREEN

This screen displays alarm messages and programmable status messages. Messages are displayed according to priority, with the shutdown alarms having highest priority, and status messages having lowest priority.

If an alarm becomes active, the display will switch to this screen and display the highest priority alarm message. The back light and alarm LED will flash. The user must press the enter key to accept the alarm, at which time the back light will be on continuously. If the alarm is non-latching, the alarm message will clear as soon as the condition is cleared. If the alarm is a latching alarm, then the user must press the reset key to clear the message. Once a message has cleared, the display will show the next priority alarm message.

After an alarm has been accepted (see Section 2.5.1), the user is able to scroll through other active alarm and message screens using the up and down arrow keys.

◆ 2.3.5 INSTRUMENTATION SCREEN

This screen displays one of the analog signal values. Pressing the up or down arrow keys will scroll to other analog display screens. Refer to the F PANEL DISPLAY MAP (Appendix 2) to see the displayable readings and how to get to them.

◆ 2.3.6 PARAMETER ENTRY SCREEN

This screen allows the user to modify the various set points and programmable options. See the "Programmable Parameters" (Section 2.7, page 12) of this manual for more specific option information. The user must press the Enter key when this screen is displayed and will be prompted for a password. The password is a six-digit number and the default value is 000000. However, the user will be able to change the password. Digits are selected by using the up and down arrow keys, and the cursor is moved by using the left and right arrow keys. When the user presses the Enter key, the password will be checked. If the password is correct, the display will show one of the data entry screens.

There are three parameter entry menus: "Engine Parameters", "System Alarm", and "AVR Parameters". The user will be able to scroll through the various parameters in each menu using the up and down arrow keys. The left and right arrow keys are used to switch between the three menus. When a parameter that requires changing is displayed, the user presses the Enter key to enable data entry. A cursor will appear at the first character that can be altered. The user can then change the character using the up and down arrow keys. The user can move to the next character or previous character using the left and right arrow keys. Pressing the Enter key will accept the new setting. Pressing the Reset key will ignore the new setting.

If an alarm condition occurs when the user is entering data, the data will be ignored, and the display will show the alarm screen. If a status condition occurs when data is being entered, the display will not change.

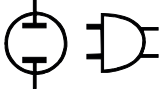

"F" PANEL OPERATIONS FLOW CHART

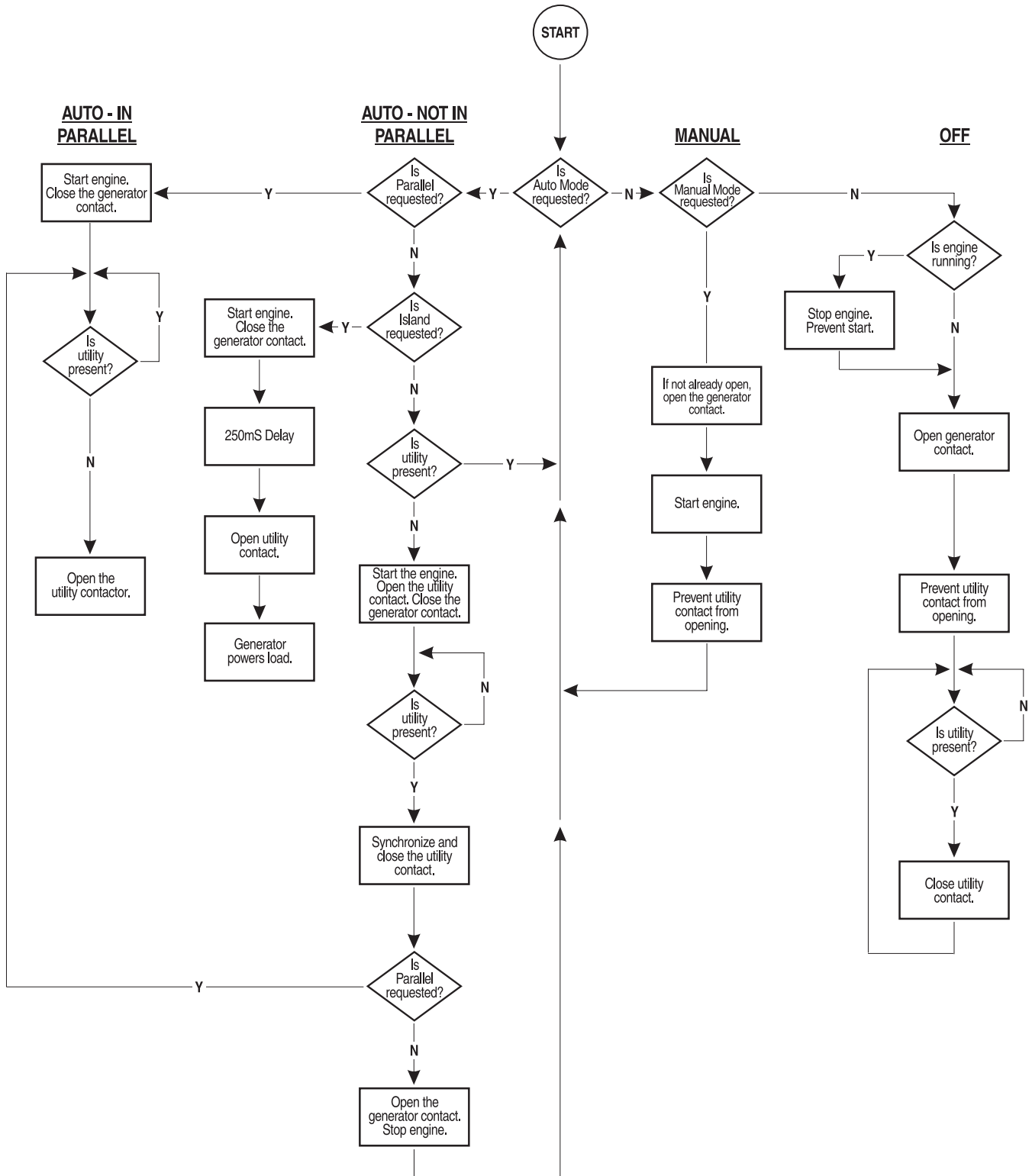

ALARMS

Alarm Message	Alarm Active	Alarm Type
Pre-Low Oil Pressure Warning	Hold Off	Non-Latch
Low Oil Pressure shutdown Alarm	Hold Off	Shutdown
Pre-High Coolant Temp. Warning	Hold Off	Non-Latch
High Coolant Temp. Shutdown Alarm	Hold Off	Shutdown
Low Coolant Temp. Warning	Always	Non-Latch
Pre-High Oil Temp. Warning	Immediate	Non-Latch
High Oil Temp. shutdown Alarm	Hold Off	Shutdown
Low Battery Voltage Warning*	Always	Non-Latch
Overspeed Alarm	Immediate	Shutdown
Underspeed	Hold Off	Non-Latch
Overcrank Alarm	Immediate	Shutdown
Over Voltage	Hold Off	Shutdown
Under Voltage	Hold Off	Non-Latch
Over Frequency	Hold Off	Shutdown
Under Frequency	Hold Off	Non-Latch
High Fuel Warning	Always	Non-Latch
Low Fuel Warning	Always	Non-Latch
Critical Low Fuel Shutdown Alarm	Always	Shutdown
Low Coolant Level Alarm	Hold Off	Shutdown
Emergency Stop	Always	Shutdown
RPM Sensor Failure Alarm	Always	Shutdown
Start Inhibit – Oil Pressure	Immediate	Shutdown
Oil Pressure Sensor Failure	Always	Shutdown
Oil Temp. Sensor Failure	Always, Disabled	Shutdown
Coolant Temp. Sensor Failure	Always	Shutdown
High Battery Voltage Warning	Always	Non-Latch
Transfer Switch Fault	Always	See Transfer Error Alarms chart on page 15
Internal Communications Fault	Always	Shutdown

* Battery voltage must be below alarm limit for 5 minutes to trigger alarm.

Once the user has finished entering data by pressing the Enter key, pressing the Reset key will allow the user to select other screens using the left and right arrow keys.

◆ 2.3.7 ALARM LOG SCREEN

The alarm log screen will display the last alarm logged. The last 19 alarms will be stored in memory. The user can scroll through these with the up or down arrow keys.

Each alarm is logged with additional information about the state of the utility voltage, generator voltage, etc., at the time of the alarm. The display will cycle through these readings for the currently displayed alarm.

2.4 ALARMS

The DG 50 has a built-in alarm system to alert service personnel of operational conditions which require attention. See Section 2.5 for instructions on how to respond to these alarms. There are three basic types and three different activity settings as described below.

◆ 2.4.1 ALARM TYPES

- Non-latching — These alarms clear themselves once the alarm condition has ended.
- Latching — These alarms must be manually cleared even after the alarm condition has ended.
- Shutdown — Similar to latching alarms but they shut down operation of the unit and can only be reset by turning the key switch to the off position.

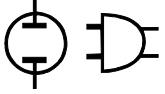

◆ 2.4.2 ACTIVITY SETTINGS

- Always — This setting leaves the alarm always active, even when the unit is not operating.
- Immediate — This setting leaves the alarm inactive when the unit is not running but activates as soon as the unit starts to crank and remains active until the unit stops.
- Hold Off — Similar to Immediate, except that there is a programmable delay after startup before the alarm becomes active. The same delay time applies to all Hold Off type alarms.

2.5 RESPONDING TO ALARMS

◆ 2.5.1 ACCEPTING AN ALARM

When an alarm condition occurs, the alarm LED and the display backlight start flashing. If an audible alarm is installed, a common alarm relay closes causing a tone to sound. The audible tone and the flashing backlight are turned off by accepting the alarm using the “Enter” key on the keypad. The alarm LED will then change to steady and any audible alarm will be silenced.

◆ 2.5.2 CLEARING AN ALARM

For non-latching alarms, the alarm is cleared when the condition is no longer present. Latching alarms must be cleared by pressing the reset key, if the alarm condition is no longer present. Shutdown alarms can only be cleared by turning the key switch to the off position.

2.6 ALARM TYPE

◆ 2.6.1 COMMON ALARM RELAY

The internal control box (F Panel) contains a relay which operates on any Alarm or Warning. The contacts of this relay are rated at 10A 30 VDC resistive. The contacts are available for customer connections to screw terminals on the back of the F Panel (Figure 2.3). There are three voltage-free connections:

- J6-9 — Normally Open
- J6-8 — Common
- J6-10 — Normally Closed

Figure 2.3 — Rear View of F Panel

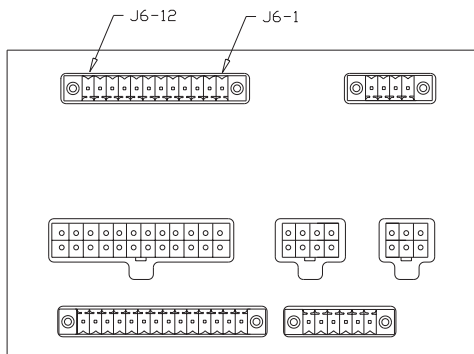

◆ 2.6.2 WARNING - NON-LATCHED

This type of warning will activate the common alarm relay and flash the alarm LED and display back light. The associated message will be displayed on the screen. When the user accepts the warning (by pressing the Enter key), the back light will stop flashing, and the alarm LED will be on continuously. The message will be displayed on the alarm screen, but the user will be able to scroll through other screens. The LED and message will clear when the warning condition clears or is cleared.

◆ 2.6.3 ALARM - LATCHED

This type of alarm will act similarly to the non-latched warning, except that the alarm does not clear when the alarm condition clears. When the alarm condition occurs, the audible alarm sounds (if so equipped), the LED and back light flash as before, and the user must accept the alarm (see Section 2.5.1) to stop them. The alarm will continue to be displayed on the screen even after the alarm condition has cleared. The user must either press the Reset key or turn the key switch to the OFF position to clear the alarm after the alarm condition has cleared. The common alarm relay will activate.

◆ 2.6.4 SHUTDOWN

This type of alarm will act similar to the latched alarm, but it also will stop the engine when the alarm condition occurs. It can be reset only by turning the key switch to the OFF position. All shutdown alarms are latching. The common alarm relay will activate.

2.7 PROGRAMMABLE PARAMETERS

The F option panel allows the user to configure various options to control the generator starting and stopping cycles, alarm set points and operating settings for the generator. Parameters are entered either from the control module or via the serial link using GenLink®. A description of the programmable parameters follows.

◆ 2.7.1 PREHEAT ENABLED

This parameter determines how the preheat function works. The preheat can be fully disabled, enabled before starting only (for the duration of the preheat time), or before and during starting (for the duration of the preheat time and also while the starter is engaged). Note that if the user wishes to engage the preheat during starting, but not to have a preheat before starting, it is possible to set the preheat time to zero.

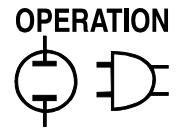

◆ 2.7.2 PREHEAT TIME

When a start command is received, the engine may require preheating before the generator attempts to start. If the preheat function is enabled, this parameter allows the user to determine the time that the preheat contact closes before activating the starter solenoid (if so equipped).

◆ 2.7.3 EXERCISE OPTIONS

This parameter decides whether to simply run the engine when exercising the unit or to also do a transfer and run in parallel. Running in parallel also tests and exercises the transfer switch. Exercise times are set from the exerciser module.

◆ 2.7.4 USER PASSWORD

The user can reset the password. This is a six-digit number and is set to 000000 at the factory.

◆ 2.7.5 PANEL ID

Each panel can have a unique six digit ID number. This allows the unit to be identified from GenLink® and also from the PowerManager™. In multiple generator installations with the PowerManager™, separate I.D.'s are necessary to allow the PowerManager™ (and GenLink®, version 6.11 and above) to route the data to the correct generator. The number is initially programmed to 000000 and can be altered by the user/installer. In a multi generator configuration, the installer will set up these "addresses" and they **SHOULD NOT BE CHANGED BY THE USER**. Changing them will render the generator unusable by the PowerManager™.

◆ 2.7.6 RESTORE DEFAULTS

By selecting this option, the factory set default parameters (as listed in the appendix) will be loaded into the parameters, overwriting the existing values. This should only be necessary if the parameters have been lost. In order to restore all settings to the factory defaults, a master pass code is necessary.

◆ 2.7.7 RUNNING HOURS

The F panel keeps track of how many hours the engine has been running. This is displayed in hours and tenths of hours. Any run of less than six minutes duration will not be recorded. This parameter is for display only.

◆ 2.7.8 FLYWHEEL TEETH

This parameter holds the number of flywheel teeth. This value is used to determine the engine speed from the magnetic pickup signal.

◆ 2.7.9 STARTER DISENGAGE SPEED

This is the speed at which the engine should be self sustaining and the point at which the starter disengages. It can be reset by the user and is normally set to 500 rpm.

◆ 2.7.10 NUMBER OF START ATTEMPTS

This parameter will determine how many times the engine will crank in an attempt to start the engine. For example, if it is set to two (2), the engine will crank two (2) times with a pause in between each crank cycle. If it fails to start, an overcrank alarm will be displayed.

◆ 2.7.11 START TIMER

Once a start command has been received and the preheat time has expired (if enabled and so equipped), the starter solenoid will engage. This parameter allows the user to determine how long the starter solenoid is engaged before the start attempt is regarded as having failed. If the generator does not start within this time, the generator will wait for a preset time before attempting to start again. The user also can program the number of start attempts.

◆ 2.7.12 START ATTEMPT PAUSE TIME

If the generator does not start within the programmed start time, it will pause before trying to start again. This parameter determines the length of that pause.

◆ 2.7.13 COOL DOWN TIME

This parameter determines the length of time that the generator continues to run after a stop command is received in AUTO mode in order to cool down the engine with no load.

NOTE:

If the key switch is turned to the OFF position when the generator is running, it will stop immediately regardless of this setting.

◆ 2.7.14 WARM UP TIME

Some applications require that the generator run for a given time before a load is applied. This parameter allows the user to set that time. Normally it will be set to zero seconds. The generator is ready to accept load when this timer expires.

◆ 2.7.15 ALARM HOLD OFF TIME

Once the engine has started, some alarm functions (such as low oil pressure and under speed) are not activated immediately since the engine must be given time to reach a stable condition. This parameter determines the time that elapses before the hold off alarms are activated.

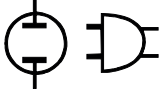

2.8 PROGRAMMABLE AVR PARAMETERS

◆ 2.8.1 POWER OUTPUT SET POINT SOURCE

This parameter allows the user to select where the power set point comes from. The set point can be an analog input (0-5 VDC) or can be set as a fixed value in the AVR parameters. When the PowerManager™ is connected and operating in peak shave mode, any power demands it sends to the generator will override all other power settings.

◆ 2.8.2 GENERATOR VOLTAGE CALIBRATION

This allows the user to calibrate the generator voltage against a calibrated meter. The range is 0.900 to 1.100. If the AC voltage set point is set to 480 VAC, and the meter shows 490 VAC, then INCREASE the scaling factor until the output voltage is correct. The reverse applies to a low voltage. The calibration is normally done at the factory. Correct readings are important to minimize circulating currents at the moment of paralleling.

◆ 2.8.3 UTILITY VOLTAGE CALIBRATION

This allows the user to calibrate of the utility voltage against a calibrated meter. The range is 0.900 to 1.100. If the utility AC voltage is 480 VAC, and the meter shows 490 VAC, then DECREASE the scaling factor until the output voltage is correct. The reverse applies to a low voltage. This method is the opposite of calibrating the generator voltage. The calibration is normally done at the factory. Correct readings are important to minimize circulating currents at the moment of paralleling.

◆ 2.8.4 POWER FACTOR

In parallel mode, the power factor of the generator can be set by this value. If the PowerManager™ is connected, it will then override this setting if operating in peak shave mode. The power factor can be set from 80 to 100, representing 0.8 to 1.00 lagging.

◆ 2.8.5 POWER OUTPUT SET POINT

This parameter should be programmed to the desired power output of the generator in parallel mode. It cannot affect the generator when operating in standby or when peak shaving. It can be programmed from 0-50 kW, however, at low powers, the power factor will not be tightly held. The power output set point source should be set to "on screen".

2.9 GOVERNOR PARAMETERS

These parameters adjust the stability and dynamic frequency (and to some extent, the voltage) response of the generator to changing loads IN STANDBY MODE ONLY. They are normally factory set and should not need altering.

◆ 2.9.1 GAIN

Increase this value to speed up the response, but not so much as to make the unit unstable. Ensure the unit is still stable at all loads when testing new values.

◆ 2.9.2 STABILITY

Increase this value to stabilize the frequency reading but reduce the dynamic response. Ensure the unit is still stable at all loads when testing new values.

◆ 2.9.3 DIFFERENTIAL

Increase this value to improve the dynamic response. Ensure the unit is still stable at all loads when testing new values.

2.10 DROOP GAIN

NOT USED. RESERVED FOR FUTURE USE.

2.11 DROOP SELECT

NOT USED. RESERVED FOR FUTURE USE.

2.12 UNDER FREQUENCY SLOPE

This parameter controls the output voltage roll off when the generator is suddenly loaded such that its frequency temporarily drops. To allow the generator to recover, it drops its voltage and thus power output until the frequency recovers. The amount by which it drops voltage is proportional to the drop in frequency below the under frequency corner. The amount is controlled by this parameter which can be set from one to three where one is the smallest amount. It is factory preset and should only need changing if the generator struggles to recover from a sudden load application.

2.13 UNDER FREQUENCY CORNER

This is the frequency below which the generator will shed output volts to allow it to recover from a large sudden load application (as described as above). It is factory preset and should only need changing if the generator struggles to recover from a sudden load application.

2.14 VOLTAGE STABILITY AND GAIN

These parameters adjust the stability and dynamic voltage response of the generator to changing loads IN STANDBY MODE ONLY. They are normally factory set and should not need altering.

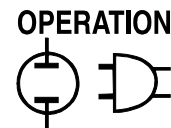

◆ 2.14.1 STABILITY

This parameter affects the stability of the generators output voltage. Increasing this parameter, improves the stability but may adversely affect load dumps or block loads. Ensure the unit is stable at all loads when testing new values.

◆ 2.14.2 GAIN

This parameter improves the dynamic response of the generator to a changing load. Increasing this value improves the response. Ensure the unit is stable at all loads when testing new values.

2.15 FREQUENCY SET POINT

This parameter sets the nominal output frequency in standby mode only.

2.16 AC VOLTAGE SET POINT

This parameter sets the nominal output AC voltage in standby mode only.

2.17 PROGRAMMABLE ALARM SET POINTS

◆ 2.17.1 OIL PRESSURE ALARMS

The oil pressure input has two associated alarm functions. Both only operate after the hold off time has expired and both operate the common alarm relay. The pre-oil pressure warning is a non-latched, hold off alarm with a user-definable set point. The low oil pressure shutdown alarm has a user definable set point and will shut down the generator. The shutdown alarm set point should be the lowest of the two settings so that there is a warning of a low oil condition before the generator shuts down.

◆ 2.17.2 OIL TEMPERATURE ALARMS

The oil temperature has two associated alarm functions. The oil temperature warning is a non-latched, immediate alarm. The oil temperature shutdown is a shutdown alarm that operates after the hold off timer expires. Both alarm functions have programmable set points and both operate the common alarm relay.

TRANSFER ERROR ALARMS

Transfer Error	Meaning	Possible Cause
1	Gen contact failed to trip	The auxiliary contact on the transfer switch may be faulty. The transfer switch may be faulty . The interposing relays may be faulty. The voltage may be low.
2	Gen contact failed to close	The auxiliary contact on the transfer switch may be faulty. The transfer switch may be faulty . The interposing relays may be faulty. The voltage may be low. The checksynch board may be faulty.
3	Utility contact failed to close	The auxiliary contact on the transfer switch may be faulty. The transfer switch may be faulty . The interposing relays may be faulty. The voltage may be low. The checksynch board may be faulty.
4	Utility contact failed to trip	The auxiliary contact on the transfer switch may be faulty. The transfer switch may be faulty . The interposing relays may be faulty. The voltage may be low.
7	Synchronizer timeout	Failed to sync in time with the utility. The controller may be faulty. The checksynch board may be faulty. The wiring may be faulty. A relay may be faulty. The throttle control may be unstable.
8	Negative power fault	Power flowed into the generator. Check the Current Transformer, ensure unit can run at full power in standby.
10	MCB open	The main circuit breaker is open, reset.
11	Contact failed to latch	Mechanical problems with the transfer switch, it bounced in and out. Check it's mechanical adjustment.
15	Indeterminate fault	Failed to close either transfer switch contact on mutiple retries.

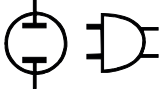

◆ 2.17.3 COOLANT TEMPERATURE ALARMS

The coolant temperature input has three associated alarms. The pre-high coolant temperature alarm is a non-latched, hold off alarm. The high coolant temperature alarm is a shutdown alarm that operates after the hold off timer expires. The low coolant temperature warning is a non-latching, always active alarm. Set points for each alarm are programmable. The alarms operate the common alarm relay.

◆ 2.17.4 BATTERY VOLTAGE ALARMS

The low battery voltage warning set point is programmable. The warning will be activated if the battery voltage is below this value for more than five minutes. This is a non-latched, always active alarm. The "Power" LED on the front panel will not be lit if the battery voltage is less than this value. The high battery voltage alarm set point is also programmable. The warning is active immediately when the battery voltage is higher than this value. The alarms operate the common alarm relay.

◆ 2.17.5 ENGINE SPEED ALARMS

The user can program the overspeed and the underspeed alarms. The overspeed alarm is an immediate shutdown alarm. Underspeed is a non-latched, hold off alarm. The alarms operate the common alarm relay.

◆ 2.17.6 GENERATOR VOLTAGE ALARMS

A hold off alarm can be generated for high voltage and low voltage, the set points are user-definable. The high voltage alarm is a shutdown alarm, the under voltage alarm is non-latched, both operate after the hold off timer expires. The alarms operate the common alarm relay.

◆ 2.17.7 GENERATOR FREQUENCY ALARMS

A hold off alarm can be generated for high frequency and low frequency. The set points are user-definable. The high frequency alarm is a shutdown alarm, the under frequency alarm is non-latched, both operate after the hold off timer expires. The alarms operate the common alarm relay.

◆ 2.17.8 FUEL LEVEL ALARMS

The fuel level sensor has three associated alarms. The high fuel and low fuel warning alarms are non-latching, always active alarms with user-definable set points. The critical low fuel shutdown alarm is always active and is a shutdown alarm. The alarms operate the common alarm relay.

◆ 2.17.9 OVERCRANK ALARM

This alarm is unlike other alarms as it is not associated with an analog or digital signal. The user is able to define the number of crank attempts, the length of each crank attempt and the rest time between cranks. After the last start attempt has been made, an overcrank alarm will be generated. The alarm operates the common alarm relay.

◆ 2.17.10 COOLANT LEVEL ALARM

This alarm is generated by the coolant level detector. This device senses whether coolant is present or not. It has no user-definable level setting and is a shutdown alarm that is active after the hold off timer expires. There are no user-definable parameters for this alarm. The alarm operates the common alarm relay.

◆ 2.17.11 TRANSFER ERROR ALARMS

If the transfer switch fails or the unit fails to go into parallel, a transfer error alarm will be displayed and the generator shut down. The alarms operate the common alarm relay. See the table on page 15 for an explanation of the alarms.

◆ 2.17.12 INTERNAL COMMUNICATION ALARM

If this alarm is displayed and cannot be reset, the control panel is faulty and should be replaced. The alarm operates the common alarm relay and is a shutdown alarm.

2.18 PARALLEL OPERATION

The DG 50 is capable of running in parallel with the utility supply (its output can be directly connected to the utility supply via the transfer switch). In order to do this, the output voltage, frequency and phase of the generator must match that of the utility. When the unit is commanded to "parallel", the control system matches all of these parameters and then closes the transfer switch onto the utility. It then acts simply as a power generator. The power the unit produces and the power factor are programmable via the LCD screen. The power can also be programmed to take it's set point from an analog (0-5 VDC) input. Tolerances for paralleling (eight cycles) are:

- less than $\pm 6V$ difference
- less than ± 0.5 Hz difference
- less than $\pm 10^\circ$ synch difference

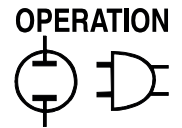

◆ 2.18.1 SETTING UP

Put the key switch in the OFF position and the parallel switch in the off position. Ensure the unit main circuit breaker is closed and that utility power is present. Confirm this by looking at the utility voltage reading on the LCD panel. Ensure that the voltage readings have been calibrated (this is normally done at the factory). To do this, check that the actual generator voltage and utility voltage agree with the readout on the LCD display. If not, refer to the Programmable AVR parameters section - generator and utility voltage calibration (section 2.8.2 and 2.8.3).

To set up for parallel operation, enter the required power and power factor into the unit. Go to the parameter entry page and then select "AVR PARAMETERS". First ensure that power is selected to come from "on screen" parameters and not from an analog (0-5 VDC) source. Set the power required (0-50 kW) then set the power factor (80 - 100 is 0.8 to 1.0 pf). Turn the key switch to the AUTO position, the unit should not start. Put the parallel toggle switch in the parallel position, the engine will start and take several seconds to synch to the utility. The transfer switch will then close and power will slowly build up to the programmed level. This is done by looking at the measured power (or current) on the screen. The measured power factor can also be seen on the screen. Note that at low power settings (less than 10 kW) the power factor will not be tightly held.

◆ 2.18.2 REMOTE OPERATION (GENLINK®)

The Generator can be put into parallel or island operation mode by using the PC based communication package - GenLink® (version 6.11 and above, part number OD3704). The same rules apply in this case as for local operation provided the key switch switch is in auto mode. See the GenLink® manual for details on how to run GenLink®. Connect the PC either directly to the serial port using a serial cable (part number OD4600) or connect a modem to the serial port and use a PC connected through the modem. See the "Modbus for the DG 50" manual (part number OD2901) for serial port and modem information. Go to the parameters menu and enter the desired power, power factor and select "on screen" as the power source. On the main screen start the generator via the start button. When the generator has started, press the parallel button. Time will pass and the generator will get in synch and the transfer switch will close into parallel. The power and power factor will be displayed on the GenLink® screen. To exit parallel, press the stop button. If exiting GenLink® while still in parallel, the unit will continue to parallel. If GenLink® accidentally disconnects, the unit will exit the parallel mode and the engine will stop. The utility breaker will remain closed, supplying utility power to the load.

◆ 2.18.3 PARALLEL ERRORS

If the unit fails to parallel for any reason, a transfer error will be displayed. The table on page 15 lists the current errors and their possible causes.

◆ 2.18.4 LOSS OF UTILITY IN PARALLEL

If utility power is lost while in parallel, the unit will revert to standby operation. When utility power returns, the unit will return to parallel operation. Losing utility power also encompasses losing one phase, low or high utility voltage (10%) or poor utility frequency. See the "F panel operations flowchart" (page 10) for more detail.

2.19 ISLAND OPERATION

In this mode, the DG 50 will power the load connected to load terminals (T1, T2, and T3) of the transfer switch even with a utility supply available.

The operational sequence is the same as parallel operation except that shortly after connecting (250ms) in parallel to the utility supply, the utility contact is opened, leaving the DG 50 to carry the load. This provides a closed transition transfer of the load from utility to the DG 50.

2.20 SERIAL COMMUNICATIONS

The control panel has both an RS232 and an RS485 communication port. Both of these ports can be used at the same time to communicate with various devices. Unless a remote annunciator or relay panel is configured to be connected to a port, all communications use the industry standard Modbus protocol (in binary format).

◆ 2.20.1 GENLINK®

The control panel can communicate with GenLink® (version 6.11 and above, part number OD3704), which is a PC based program allowing both communication with the generator and remote alteration of its parameters. The user will be able to start and stop the generator if it is in AUTO mode. GenLink® communications can be either local via a serial link, or remote via a modem and can be connected to either port. If a modem is used, the control panel communications parameters must be set to "modem."

◆ 2.20.2 REMOTE ANNUNCIATOR-RELAY PANELS

The serial connections can be configured to allow the control panel to connect to properly configured remote annunciators and/or remote relay panels, on either port. If the RS232 port is used, a RS232 to RS485 converter box (part number OD1460) will be required. More than one RAP/RRP can be connected to the port in daisy chain fashion. See the Remote Annunciator Manual (part number 0A7450) for connection details.

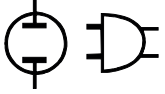

◆ 2.20.3 BUILDING MANAGEMENT

The control panel can be connected to a building management system to allow communication and alteration of the internal parameters. The generator can be started from this connection if the key switch is in the AUTO position. All communication uses Modbus protocol. See the document “Modbus for the DG 50” (part number 0D2901) for connections and protocol details.

◆ 2.20.4 METHOD OF CONNECTION

If the DG 50 is used in conjunction with Generac's PowerManager™ product, it will communicate with the PowerManager™ via the RS485 port. GenLink® will communicate with the panel via the PowerManager™. Multiple generator sets can be linked to the PowerManager™ via this port, and GenLink® can communicate with each one individually. If a remote annunciator or remote relay panel is required, it has to be connected to the RS232 port (via a 232/485 converter, part number 0D1460). In this way, each unit can have a separate annunciator. GenLink® could also communicate locally via a laptop to the RS232 port (if no other devices are connected) but this is not recommended. A building management system would connect to the PowerManager™ module via a separate RS485 port on the PowerManager™ module. If GenLink® is not being used, it could be connected to the RS232 port but this is not recommended.

If the PowerManager™ module is not connected, then the RS485 port is used for the remote devices (annunciator or relay) and the RS232 port is used for GenLink® (via modem or serially). A building management system can connect to either of the ports provided there is nothing else connected to it. It can be used to duplicate the remote annunciator or relay panel if required (via a customer supplied PLC). See the document “Modbus for the DG 50” (Generac part number 0D2901) for connections and protocol details.

2.21 ADDITIONAL STANDARD COMPONENTS

◆ 2.21.1 LINE PHASE SELECTOR SWITCH

The line phase selector switch is located next to the panel meters on the back of the transfer switch box. It allows the user to select which phase to monitor with the panel meters. See Figure 2.4.

◆ 2.21.2 AC VOLTMETER

This meter indicates the generator AC output voltage. By using the line phase selector switch mounted next to the meter, A - B, B - C and C - A voltage can be viewed. To determine the nominal rated AC voltage of the unit, refer to the unit's data plate. See Figure 2.4.

◆ 2.21.3 AC AMMETER

This meter indicates the current draw of connected electrical loads, in amps. Also see "Line-phase Selector Switch (Section 2.21.1)." For continuous operation, never exceed the rated maximum continuous current capacity of your generator. The meter is connected to the load side of the transfer switch and thus will NOT indicate power flowing back into the utility when in parallel mode. See Figure 2.4.

Figure 2.4 — Line Phase Selector Switch, AC Voltmeter & AC Ammeter

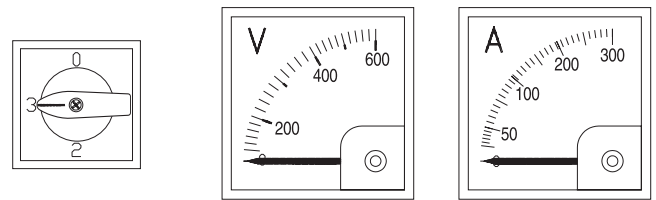

◆ 2.21.4 DC PANEL FUSE

This 15-amp fuse protects the panel components. This fuse is not to be confused with the control module internal fuse discussed in "Checking/Replacing the F Panel Control Module Internal Fuse." See Figure 2.5.

◆ 2.21.5 EMERGENCY STOP SWITCH

When pressed, this switch will automatically shut down the entire generator set. The operator must twist and pull the switch out to its original position to reset it, as well as reset the F panel to allow for generator operation.

◆ 2.21.6 MODE SWITCH

This switch (center off) is only effective when the control console key switch is in the AUTO position. When set to the “Parallel” position, the switch commands the generator to start, synchronize, and connect in parallel with the utility. It will generate a fixed amount of power as programmed in the AVR parameters menu. This power will either be supplied to a connected load or exported back to the utility company. For example, if 50 kW is selected to be generated with a 10 kW load, then 10 kW will go to the load and 40 kW back to the utility.

When set to the “Island” position, the generator starts, synchronizes with the utility (as for operator in “Parallel” mode), then momentarily connects in parallel (for 250ms). The utility contact of the transfer switch is then opened, leaving the generator supplying the load. This enables the generator to power the load even with a utility supply available.

Figure 2.5 — DC Panel Fuse, Emergency Stop Switch & Parallel Switch

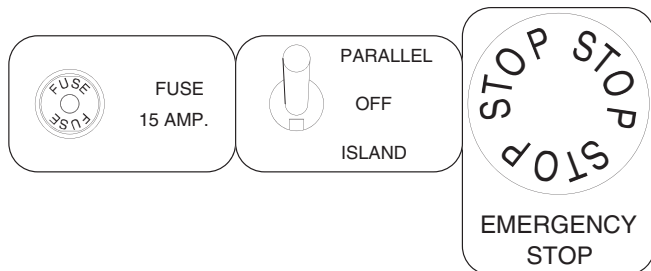

2.22 THE TRANSFER SWITCH

The Transfer Switch is located on the opposite side of the genset to the control panel. Access is made by removing the bolted cover from the box. **UNDER NO CIRCUMSTANCES SHOULD THE COVER BE REMOVED WITH LIVE UTILITY PRESENT AND/OR THE GENSET RUNNING.** Observe the safety rules.

The transfer switch consists of two 200A contactors which can close either utility supply or generator supply to the load. In paralleling mode, both utility and generator can be closed to the load (and thus to each other). With the exception of the utility trip coil (12V DC), the transfer switch is operated via 240 VAC (nominal) solenoid coils which derive their power from the appropriate live source. The generator supply can only be closed to the load if the generator is running. Similarly, the utility can only be closed to the load if utility is live. The generator can only be tripped from the load if the utility is live. The utility however, can be tripped as required.

The coils are operated by interposing relay logic in the control cabinet and are ultimately controlled from the F panel.

The status of the two switches is fed back via auxiliary contacts to the F panel, which uses these signals to indicate any fault conditions.

As described in section 2.18, synchronizing is performed (when necessary) by the F panel itself, with the checksynch board providing a secondary safety check.

Open and closed indication is provided by an indicator for both sources on the front of the switch. The switches can be manually operated with an actuator lever which is located on the base of the transfer switch enclosure. The utility and generator switches cannot be closed at the same time. The switches can also be manually tripped by depressing the respective metal pins located in the holes on the transfer switch cover.

Connection of the load is made via the three terminals T1,T2,T3 marked "customer load" on the base and to the rear of the transfer switch. Polarity of this connection may be important so **OBSERVE PHASE ROTATION** when connecting to these terminals.

Connection of the utility is made via the three terminals N1,N2,N3 marked "normal supply" on the top of the transfer switch. Polarity of this connection IS important so **OBSERVE CORRECT PHASE ROTATION** (clockwise) when connecting to these terminals.

2.23 THE CHECKSYNCH BOARD

This module is located on the floor of the control box, behind the control panel. Access is gained via a special cabinet key. **HIGH VOLTAGES ARE PRESENT IN THIS CABINET.** Observe the safety rules.

The Checksynch Board provides a secondary level of protection when the controller is trying to close both sources, utility and emergency, on the transfer switches. Both the controller and the checksynch board must agree that it is safe to close the switch before the switch will operate. In this way, if a fault develops in one of the modules, it will be caught safely by the other module.

The board monitors the incoming utility and the output of the generator. In order for the unit to parallel, the voltages, frequency, phase rotation (the Checksynch Board is clockwise only), and phase of these supplies must agree with each other (see section 2.18), for a minimum period of time, before the transfer switch is allowed to close.

The board interfaces to the transfer switch via the interposing relay logic.

There are three green LED's on the board. The LED towards the rear of the board indicates the incoming utility is within voltage and frequency tolerances. The center LED indicates that the phase rotation of the two supplies is correct (run the generator with utility present to get this to operate). The tolerances for Checksynch board are:

- less than $\pm 10\%$ voltage
- less than ± 0.5 Hz
- less than $\pm 15^\circ$

The front LED indicates when the two supplies are in phase or, in synch. As the unit tries to parallel, or is running in manual with utility present, it will illuminate for brief periods of time as the unit gets in synch.

The board will detect "deadbus" conditions (when either of the two supplies is missing) and will allow the transfer switch to close without looking for phase synchronization.

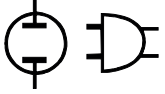

2.24 RELAY PROTECTION SCHEME

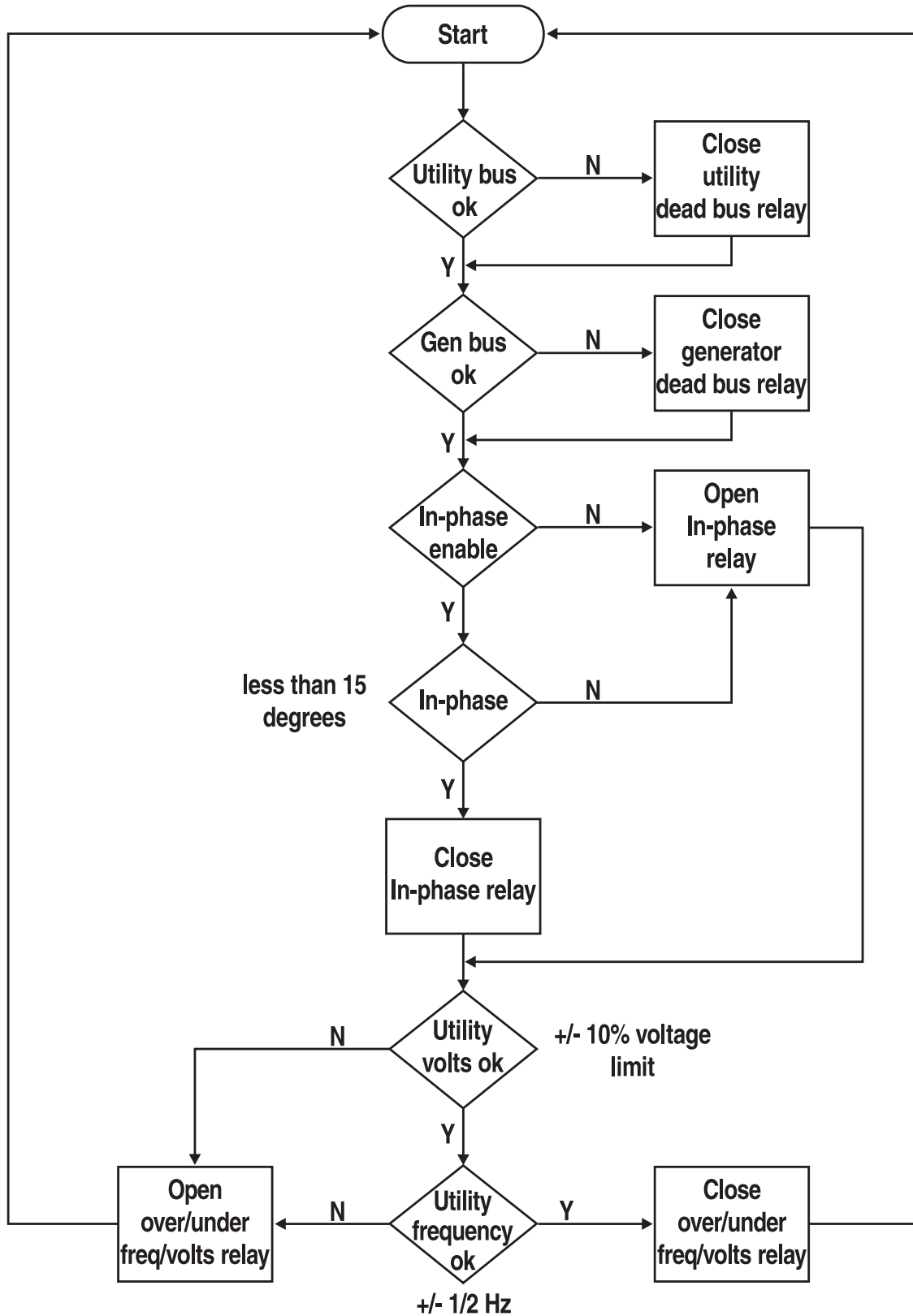

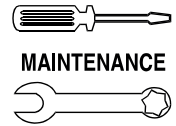

3.1 CHECKING THE ENGINE OIL LEVEL

For oil capacities, see “Specifications,” Section 1.4, Page 5. For engine oil requirements, see Section 1.6. To check the engine oil level, proceed as follows (Figures 3.1 and 3.2):

1. Remove the dipstick and wipe it dry with a clean cloth.
2. Install the dipstick fully into cap; then, remove it again. The oil level should be at the dipstick “Full” mark. If necessary, add oil to the “Full” mark only. **DO NOT FILL ABOVE THE “FULL” MARK.**
3. Install the dipstick.



⚠ Never operate the engine with the oil level below the “Add” mark on the dipstick. Doing this could damage the engine. If the oil level on the dipstick is below the “Add” mark, there may not be any reserve oil left in the reservoir. Check the reservoir oil and fill as needed per Section 3.2.2.

Figure 3.1 – Oil Dipstick and Fill

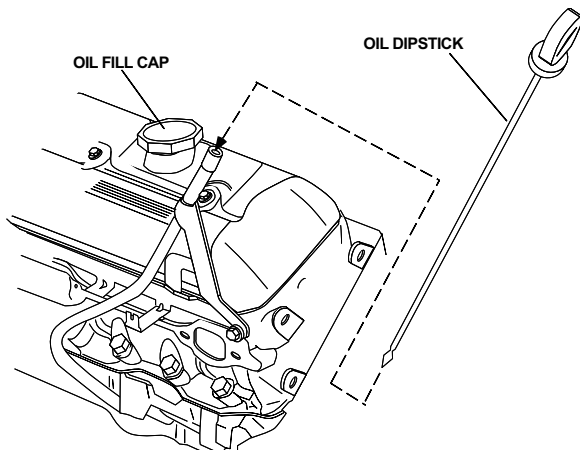

3.2 CHANGING THE ENGINE OIL AND FILTER

◆ 3.2.1 ENGINE OIL REQUIREMENTS

See Section 1.6, page 5.



⚠ Any attempt to crank or start the engine before it has been properly serviced with the required oil may result in an engine failure.

◆ 3.2.2 OIL AND FILTER CHANGE PROCEDURE

Refer to the “Service Schedule,” (Section 3.11, Page 25) for engine oil and filter change intervals.

Drain the oil while the engine is still warm from running.

The DG 50 has an extended run oil reservoir and a float valve mechanism that maintains a constant oil level in the oil pan.

The reservoir has an atmospheric vent. To avoid spillage during transit, the unit is shipped in a “semi-wet” state, with approximately one inch of oil in the reservoir. This amount of oil is enough to start the unit and run for several hours, but the upper reservoir needs to be filled according to the instructions below for extended maintenance operation.

A special pump kit (Part No. 0C8541) is available for this purpose. The kit includes a drain pump and a fill pump; one is meant for clean engine oil fill and the other for draining used engine oil out of the lower pan. To prevent cross-contamination, the fittings on the two hose assemblies are matched to the tank they are intended to drain or fill. The drain hose cannot be fitted to the reservoir and the fill hose cannot be fitted to the oil pan.

► 3.2.2.1 Draining the Engine Pan of Used Oil

1. At the recommended oil change interval, shut down the unit and connect the drain pump to the hose assembly attached to the lower pan.

NOTE:

Do not attempt drainage while the unit is operating.

2. Close the oil drain valve (Figure 3.2) and connect the pump to a 12 volt source such as the engine battery.
3. Check the direction of flow to ensure the oil is being drained out of the oil pan.

Figure 3.2 — Oil Drain Valve

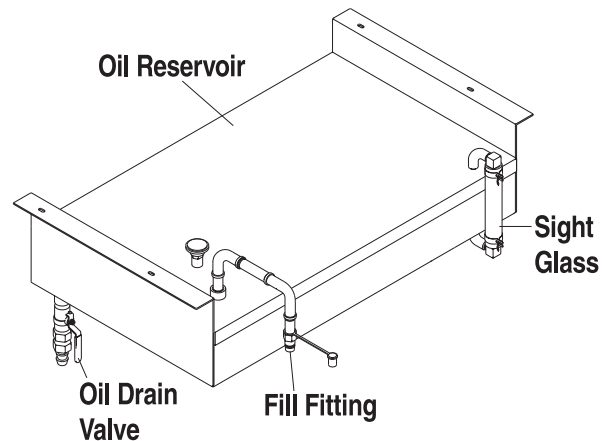

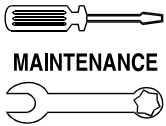

Section 3 – Maintenance

DG 50 Generator Set

- Use an oil filter wrench to turn the oil filters (Generac part number 0C3784, Figure 3.3) counterclockwise and remove them. Properly dispose of the old filters.

Figure 3.3 – Oil Filter and Air Cleaner

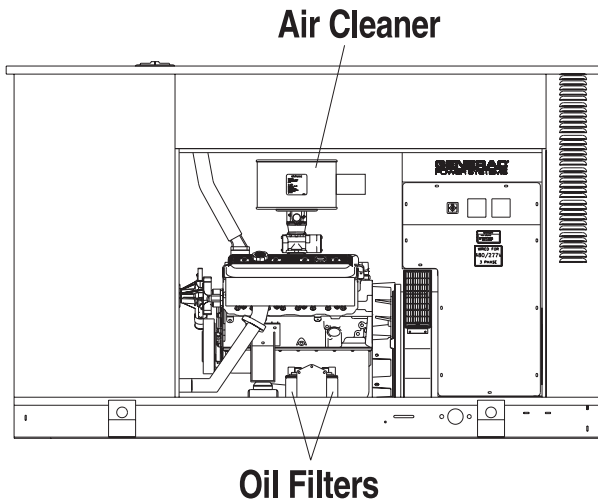

- Apply a light coating of clean engine oil to the seal of each new oil filter. Install the filters and tighten by hand only. **DO NOT OVERTIGHTEN.**

▶ 3.2.2.2 Filling the Unit With Clean Oil

- Remove the oil fill cap as shown in Figure 3.1 (page 21) and fill the crankcase with oil as specified in Section 1.6. **DO NOT FILL ABOVE THE DIPSTICK "FULL" MARK.** Crankcase capacity is listed in Section 3.12.
- The upper reservoir has a quick-disconnect fitting and a sight glass. Connect the hose from the fill pump to this fitting and pump fresh oil into the reservoir.
- Monitor the sight glass carefully and fill the reservoir to the top of the sight glass. **DO NOT OVER-FILL.**
- Open the tank valve and let the system balance to the proper level.

—▲ CAUTION ▲—

- ▲ **After refilling the crankcase with oil, always check the oil level on the dipstick. Operating the engine with the oil level below the "Add" mark on the dipstick could damage the engine.**
- Start the engine and check for oil leaks.
 - Check the oil level after checking for leaks to ensure that the oil is filled to the proper level.

3.3 OIL LUBRICATION SYSTEM COMPONENTS

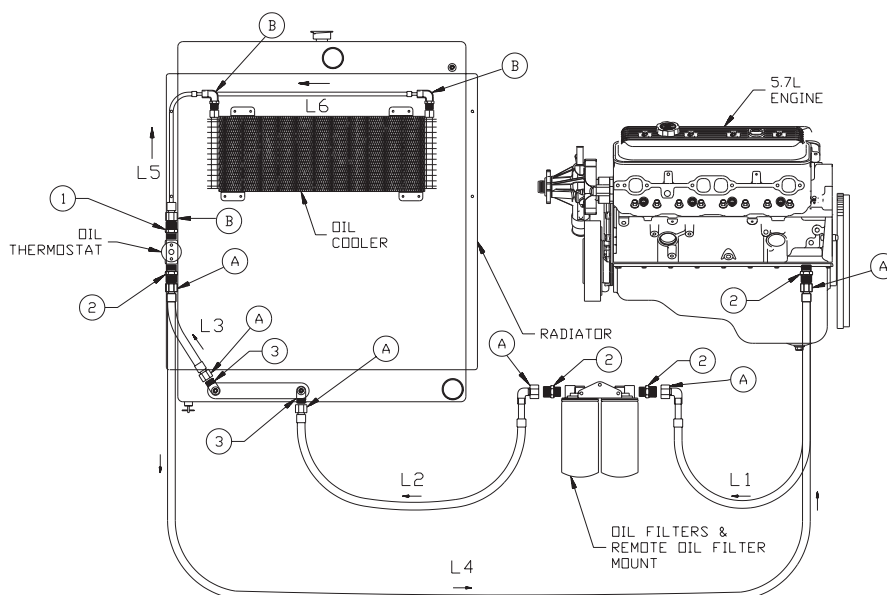

ITEM	P / N	DESCRIPTION
1	0C4975A	MALE CONN. 1/2"-14NPT TO 3/4"-16
2	0C4974	MALE CONN. 1/2"-14NPT TO 7/8"-14
3	0C4973	MALE CONN. 90° 3/4"-14NPT TO 3/4"-16
L1	0E2633A	FROM ENGINE TO FILTER
L2	0E2633B	FROM FILTER TO LOWER COOLER
L3	0E2633	FROM LOWER COOLER TO THERMOSTAT
L4	0E2633C	FROM THERMOSTAT TO ENGINE
L5	0E2633D	FROM THERMOSTAT TO UPPER COOLER (LEFT)
L6	0E2633E	FROM THERMOSTAT TO UPPER COOLER (RIGHT)
		A = 57-62 FT.-LB. TORQUE
		B = 18-20 FT.-LB. TORQUE

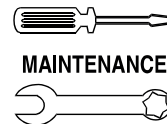

3.4 CHANGING THE ENGINE AIR CLEANER

To replace the engine air cleaner, (Generac part number 0C3197), remove the air cleaner assembly and replace the air filter making sure it is positioned properly (snout facing air intake) before reattaching the cover. See Figure 3.3.

See the “Service Schedule,” Section 3.12, Page 26, for recommended air cleaner maintenance.

3.5 SPARK PLUGS

Reset the spark plug gap or replace the spark plugs as necessary. See Section 3.12.

1. Clean the area around the base of the spark plugs to keep dirt and debris out of the engine.
2. Remove the spark plugs and check the condition. Clean the plugs using a wire brush. Do not “blast” the spark plugs to clean. Replace the spark plugs if worn or if reuse is questionable. See the “Service Schedule,” Section 3.12 for recommended inspection.
3. Check the spark plug gap using a wire feeler gauge. Adjust the gap to 0.035 inch (.89 mm) by carefully bending the ground electrode (Figure 3.4).

Figure 3.4 – Setting the Spark Plug Gap

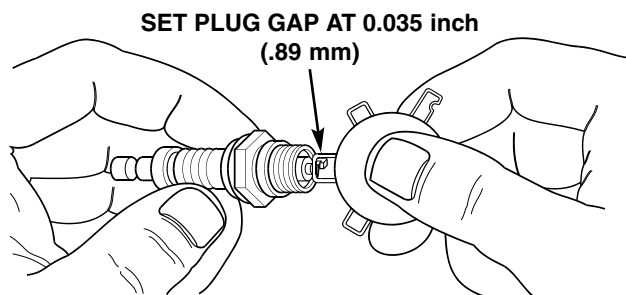

3.6 BATTERY MAINTENANCE

The battery should be inspected at intervals specified in the “Service Schedule,” Section 3.12. The following procedure should be followed for inspection:

1. Inspect the battery posts and cables for tightness and corrosion. Tighten and clean as necessary.
2. Check the battery fluid level of unsealed batteries and, if necessary, fill with **DISTILLED WATER ONLY. DO NOT USE TAP WATER IN BATTERIES. When using maintenance free batteries these procedures are not necessary.**
3. Have the state of charge and condition checked. This should be done with an automotive-type battery hydrometer or load test.

⚠ DANGER ⚠

- ⚠ Storage batteries give off explosive hydrogen gas. This gas can form an explosive mixture around the battery for several hours after charging. The slightest spark can ignite the gas and cause an explosion. Such an explosion can shatter the battery and cause blindness or other injury. Any area that houses a storage battery must be properly ventilated. Do not allow smoking, open flame, sparks or any spark producing tools or equipment near the battery.
- ⚠ Battery electrolyte fluid is an extremely caustic sulfuric acid solution that can cause severe burns. Do not permit fluid to contact eyes, skin, clothing, painted surfaces, etc. Wear protective goggles, protective clothing and gloves when handling a battery. If fluid is spilled, flush the affected area immediately with clear water.
- ⚠ Do not use any jumper cables or booster battery to crank and start the generator engine. If the battery has completely discharged, remove it from the generator for recharging.

⚠ WARNING ⚠

- ⚠ Be sure the utility power supply is turned off, or sparking may occur at the battery posts as cables are attached and can cause an explosion.

NOTE:

Disconnect the cable from the negative (-) terminal first. Reconnect the negative (-) terminal last.

- ⚠ Be sure the Auto/Off/Manual switch is set to the OFF position before connecting the battery cables. If the switch is set to AUTO or MANUAL, the generator can crank and start as soon as the battery cables are connected.

3.7 COOLING SYSTEM

Air intake and outlet openings in the generator compartment must be open and unobstructed for continued proper operation. This includes such obstructions as high grass, weeds, brush, leaves and snow.

Without sufficient cooling and ventilating air flow, the engine/generator quickly overheats, which causes it to shut down. (See Figure 3.5 on page 24) for vent locations.)

⚠ WARNING ⚠

- ⚠ The exhaust system of this product gets extremely hot and remains hot after shutdown. High grass, weeds, brush, leaves, etc. must remain clear of the exhaust. Such materials may ignite and burn from the heat of the exhaust system.

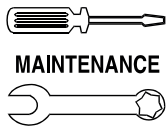
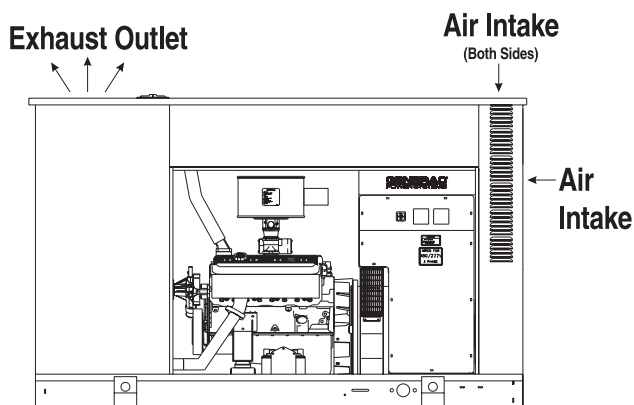

Figure 3.5 – Air Intake and Outlet Locations



3.7.1 ENGINE HEATER

This generator comes equipped with a block heater (Figure 3.6) that is similar to the block heaters used in automotive applications.

Figure 3.6 – Engine Block Heater

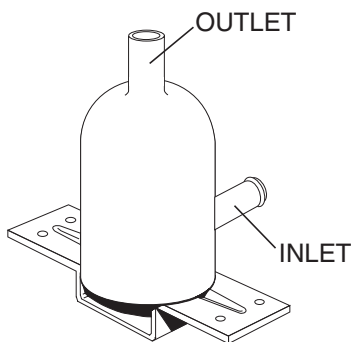

Refer to applicable wiring diagram(s) and electrical schematic(s) in this manual for wiring connections.

3.8 OVERLOAD PROTECTION FOR ENGINE DC ELECTRICAL SYSTEM

Engine cranking, start-up and running are controlled by a solid-state engine controller circuit board. Battery voltage is delivered to that circuit board via a 15-amp fuse. These overcurrent protection devices will open if the circuit is overloaded.



CAUTION If a circuit breaker opens or the fuse is open, find the cause of the overload before resetting the circuit breaker or replacing the fuse.

3.8.1 FUSE

The generator panel's 15-amp fuse (Figure 3.7) protects the DC control circuit against overload. The fuse is wired in series with the battery output lead to the panel. If the fuse element is open, the engine cannot crank or start. Replace the fuse using only an identical 15-amp replacement (part number 022676).

Figure 3.7 – Location of 15-amp Fuse

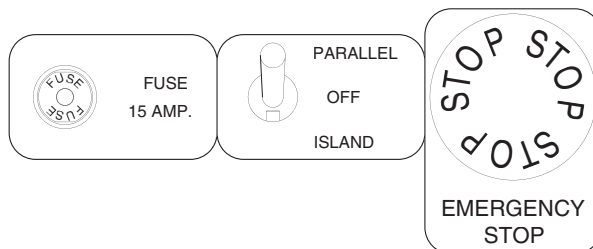

3.9 ENGINE COOLANT

- Add the recommended coolant mixture as necessary. See Section 1.4.2 on Page 5.
- Coolant should be at the bottom of the radiator filler neck. If the coolant level is low, inspect the gasket in the radiator pressure cap. Replace the cap, if necessary. To have the pressure cap tested, contact a Generac Authorized Dealer.

3.10 MISCELLANEOUS MAINTENANCE

3.10.1 CLEANING THE GENERATOR

Keep the generator as clean and as dry as possible. Dirt and moisture that accumulate on internal generator windings could have an adverse effect on insulation resistance.

Periodically, clean the generator's exterior surfaces. A soft brush may be used to loosen caked on dirt. Use a vacuum system or dry, low pressure air to remove any accumulations of dirt. The generator is housed inside an all-weather enclosure; clean the enclosure with a soft, damp cloth or sponge and water.

Although the enclosure will protect against rain entering the compartment, it is not designed to keep out high pressure water jets. Avoid the use of high pressure cleaning equipment.

Once each year, have the generator cleaned and inspected by a Generac Authorized Dealer. Service technicians use a dry, low pressure air to clean internal windings. Parts inside the control console should be cleaned and inspected at this time as well.

Finally, have the insulation resistance of stator and rotor windings checked. If insulation resistances are excessively low, the generator may require drying.



◆ 3.10.2 CLEANING THE RADIATOR

As indicated in the Service Schedule (Section 3.12), the radiator fins require periodic cleaning. Fouling of these fin openings will dramatically reduce the overall cooling capacity of the radiator and lead to frequent overheating. The fins are fragile and should be cleaned carefully. Damage to or bending of these fins will also reduce cooling capacity. Clean the fins only using a soft brush and a vacuum. A final cleaning using low pressure air directed at the fan side ONLY may help remove embedded material.

◆ 3.10.3 RODENT PROTECTION

The intrusion of rodents into the generator set can cause a wide range of problems, from failure of the unit to start, to personal injury and, in extreme circumstances, short circuit or fire. Although the unit was designed to limit this problem, further precautions can be taken by the owner to help minimize both the chance of rodent entry and the extent of any damage. Inside the generator set, the chance of rodent entry into the control panel is greatly reduced by the inclusion of adjustable wire connectors. Check that the wire connector screws are tight, thus closing off any gap between the access holes and the wires.

3.11 OUT OF SERVICE PROCEDURE

◆ 3.11.1 REMOVAL FROM SERVICE

If the generator cannot be exercised every seven days, and it is to be out of service longer than 90 days, prepare the generator for storage as follows:

1. Start the engine and let it warm up.
2. Close the fuel shutoff valve in the fuel supply line and allow the unit to shut down.
3. Once the unit has shut down, it will signal a fault on the control panel.
4. Set the Auto/Off/Manual switch to OFF and turn off the utility power to the transfer switch.
5. Set the Maintenance Disconnect switch to the Manual position.
6. While the engine is still warm from running, drain the oil completely and refill the crankcase with required oil as described in Section 3.2.2 (page 21).
7. Attach a tag to the engine indicating the viscosity and classification of the oil in the crankcase.
8. Remove the spark plug(s) and spray fogging agent into the spark plug(s) threaded openings. Reinstall and tighten the spark plug(s).
9. Remove the battery and store it in a cool, dry room on a wooden board. Never store the battery on any concrete or earthen floor.
10. Clean and wipe the entire generator.

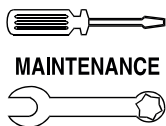

Section 3 – Maintenance

DG 50 Generator Set

3.12 SERVICE SCHEDULE

ATTENTION: It is recommended that all service work be performed by your nearest Generac Authorized Dealer.

EVERY 1000 HOURS	PROCEDURE	QUANTITY	VISUALLY CHECK
	Change Oil (Engine Crankcase)	5 Quarts	Coolant Level
	Fill Oil Tank (Reserve Tank)	10 Gallons	
	Change Oil Filters (Part Number 0C3784)	2	
	Grease DC Charge Alternator	1	Air Filter
	Grease Fan Drive Shaft Bearing	1	Radiator Hoses & Clamps
	Change Fan Belts (Part Number 0C6549)	2	Serpentine Belt Idler Bearing
	Change Serpentine Belt (Part Number 0C5482)	1	
			Spark Plugs & Wires
	Clean Radiator Fins		Radiator Fin Fouling
	Check exhaust manifold bolts. Torque to specifications listed in exploded view as necessary.		
	Check batteries per Sections 1.7 and 3.5		
EVERY 2000 HOURS	Same Items as 1000 Hour Maintenance		Same as 1000 Hour Maint.
	Change Spark Plugs (Part Number 059503)	8	DC Alternator Bearings
	Change Air Filter (Part Number 0C3197)	1	Upper & Lower Fan Drive Bearings
EVERY 10000 HOURS	Change Cylinder Heads (Remanufactured)	2	Fan Drive Shaft Bearings
	Change Head Gasket	2	Water Pump Bearing
	Change Intake Manifold Gasket	2	Serpentine Belt Tensioner & Idler
	Change Valve Cover Gasket	2	
	Change Distributor Gasket (Part Number 0C4389)	1	
	Change Distributor Cap & Rotor	1 Each	
	Change Spark Plug Wires (Part Number 0C4701)	9	



4.1 TROUBLESHOOTING GUIDE

PROBLEM	CAUSE	CORRECTION
The engine will not crank.	<ol style="list-style-type: none"> 1. Fuse blown 2. Loose, corroded or defective battery cables 3. Defective starter contactor 4. Defective starter motor 5. Dead Battery 	<ol style="list-style-type: none"> 1. Replace fuse. 2. Tighten, clean or replace as necessary. 3. * 4. * 5. Charge or replace battery.
The engine cranks but will not start.	<ol style="list-style-type: none"> 1. Out of fuel 2. Defective fuel solenoid (FS) 3. Open #14 wire from engine control board 4. Defective spark plug(s) 5. Dirty/Blocked air filter 	<ol style="list-style-type: none"> 1. Replenish fuel. 2. * 3. * 4. Clean, re-gap or replace plug(s). 5. Clean or replace as required.
The engine starts hard and runs rough.	<ol style="list-style-type: none"> 1. Clogged or damaged air cleaner 2. Defective spark plug(s) 	<ol style="list-style-type: none"> 1. Check, clean or replace air cleaner. 2. Clean, re-gap or replace plug(s).
The engine starts, but then shuts down.	<ol style="list-style-type: none"> 1. Engine oil level low 2. Defective low oil pressure switch 3. Defective high temperature switch 4. Defective control board 5. Low coolant level 	<ol style="list-style-type: none"> 1. Check oil and add oil as needed. 2. * 3. * 4. * 5. Check coolant level, repair leaks and refill.
The Auto/Off/Manual switch is set to OFF, but the engine continues to run.	<ol style="list-style-type: none"> 1. Defective switch 2. Defective control board 	<ol style="list-style-type: none"> 1. * 2. *
There is no AC output from the generator.	<ol style="list-style-type: none"> 1. Generator main line circuit breaker open 2. Generator internal failure 	<ol style="list-style-type: none"> 1. Reset circuit breaker to ON (or closed). 2. *
There is no transfer to standby after utility source failure.	<ol style="list-style-type: none"> 1. Generator main line circuit breaker open 2. Defective transfer switch coil 3. Defective transfer relay 4. Transfer relay circuit open 5. Defective control logic board 	<ol style="list-style-type: none"> 1. Reset circuit breaker to ON (or closed). 2. * 3. * 4. * 5. *

***Contact your nearest Generac Authorized Dealer for assistance.**

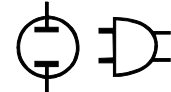

STANDARD CONFIGURATIONS

GROUP	PARAMETER	DEFAULT VALUE	CHANGED ON TEST TO:
Alarms	Fuel Level Alarm On/Off	Off	
	Battery High	15	
	Battery Low	10	
	Underfrequency	50	
	Overfrequency	70	
	Low Fuel Shutdown	0	
	Fuel Level Low Warning	5	
	Fuel Level High Set point	80	
	Undervoltage	350	150 for 208V
	Overvoltage	580	270 for 208V
	Overspeed	2300	
	Underspeed	1500	
	Coolant Low Temperature Shutdown Alarm	0	
	Coolant High Temperature Shutdown Alarm	245	
	Coolant High Temperature Warning	235	
	Oil Temperature shutdown Alarm	245	265
	Oil Temperature Warning	235	245
Oil Pressure Shutdown Alarm	15	10	
Oil Pressure Warning	25	15	
Engine	Port Setting	Modem	
	Preheat	No	
	Exercise	No Transfer	
	Flywheel Teeth	168	
	Start Disengage Speed	500	
	Start Attempts	3	
	Cool Down	0	1 min.
	Warmup	0	
	Alarm Hold Off	8	
	Start Pause	5	
	Start Timer	4	
Preheat Timer	0		
AVR	Generator Model Number	DG 50	
	Power Source Select	On Screen	
	Generator Voltage Scaling	0.970	
	Utility Voltage Scaling	0.960	
	Power Factor	90	
	Power	50 kW	
	Governor P Gain	20	7 for 208/15 for 480
	Governor I Gain	50	150 for 208/120 for 480
	Governor D Gain	70	60 for 208/60 for 480
	AVR Droop	0	
	Droop Select	1	
	Slope	1	
	Corner Frequency	57	
	AVR Stability	35	
	AVR Gain	40	10 for 208V
	Frequency	60	
	Voltage	480	208 for 208V

OPERATION

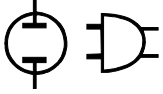

Appendix 2 – F Panel Operations Display Map

DG 50 Generator Set

GENERATOR STATUS	ALARM STATUS	INSTRUMENTATION	PARAMETER ENTRY	SOFTWARE VERSION	GENERATOR COMMAND
Stopped ready to run* *This is true as long as there are no alarm conditions	No Active Messages* *This is true as long as there are no messages	Generator Voltage A.X B.X C.X or Power Factor X.XX or Generated Power X kW or Coolant Level X% or Generated Amps X Amps or Utility Frequency XX Hz or Utility Volts X Volts or Hours Run XXXXX.X Hours or Fuel Level X% or Battery Voltage XX Volts or Oil Pressure X p.s.i. or	Parameter Entry Enter Password XXXXXX Enter Engine Parameter Menu Running Hours XXXXX.X or RS 232 Port Direct Connection or RS 232 Port Modem Connection Restore All Values to Default Settings or Panel I.D. XXXXXX User Password XXXXXX Preheat Option No Preheat or Preheat Option Before and During Start or Preheat Option Before Start	Generac Digital Panel Software Version X.XX Enter* *Display test, all pixels black, all 4 LED's will be on	Generator Switch Off or Generator Switch Off Turn Key to Auto Mode Generator in auto Mode Stop Command Turn Key to Manual Mode Attempting to Start Attempt Number X
			Alarm Log Next Log • • •	System Alarm Menu or Fuel Level Alarm On/Off X or Battery Volts High Seipt X.X V or Battery Volts Low Seipt X.X V or Under Freq. Seipt X Hz or Over Freq. Seipt X Hz or Low Fuel Shutdown Spt X or Fuel Level Low Seipt X or Fuel Level High Seipt X	AVR Parameter Menu or Model Number or Power Selection On Screen or Power Selection Analog Port or Gen. Volts Scale (+/- 5%) X or Util. Volts Scale (+/- 5%) X or Power Factor (80-100) X or Seipoint Power (kW) X kW or Governor Gain X or

Appendix 2 – F Panel Operations Display Map

DG 50 Generator Set

OPERATION

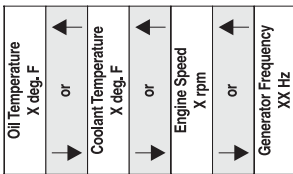
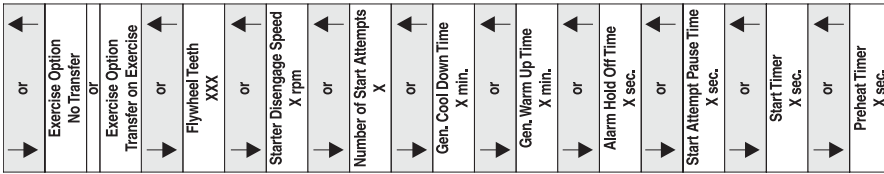
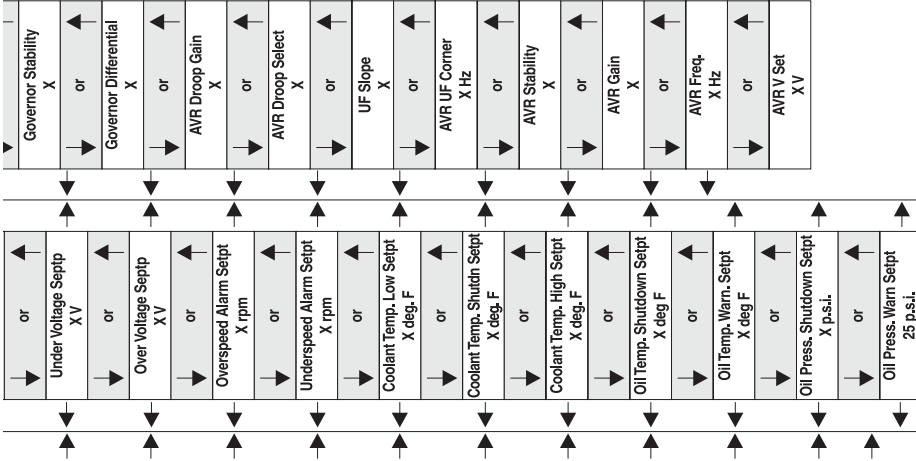
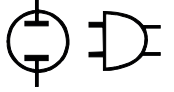

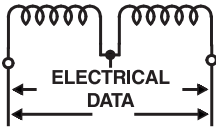

Section 6 – Electrical Data

DG 50 Generator Set

Wiring Diagram (120/208V Connection Box) – Drawing No. 0C7703-C

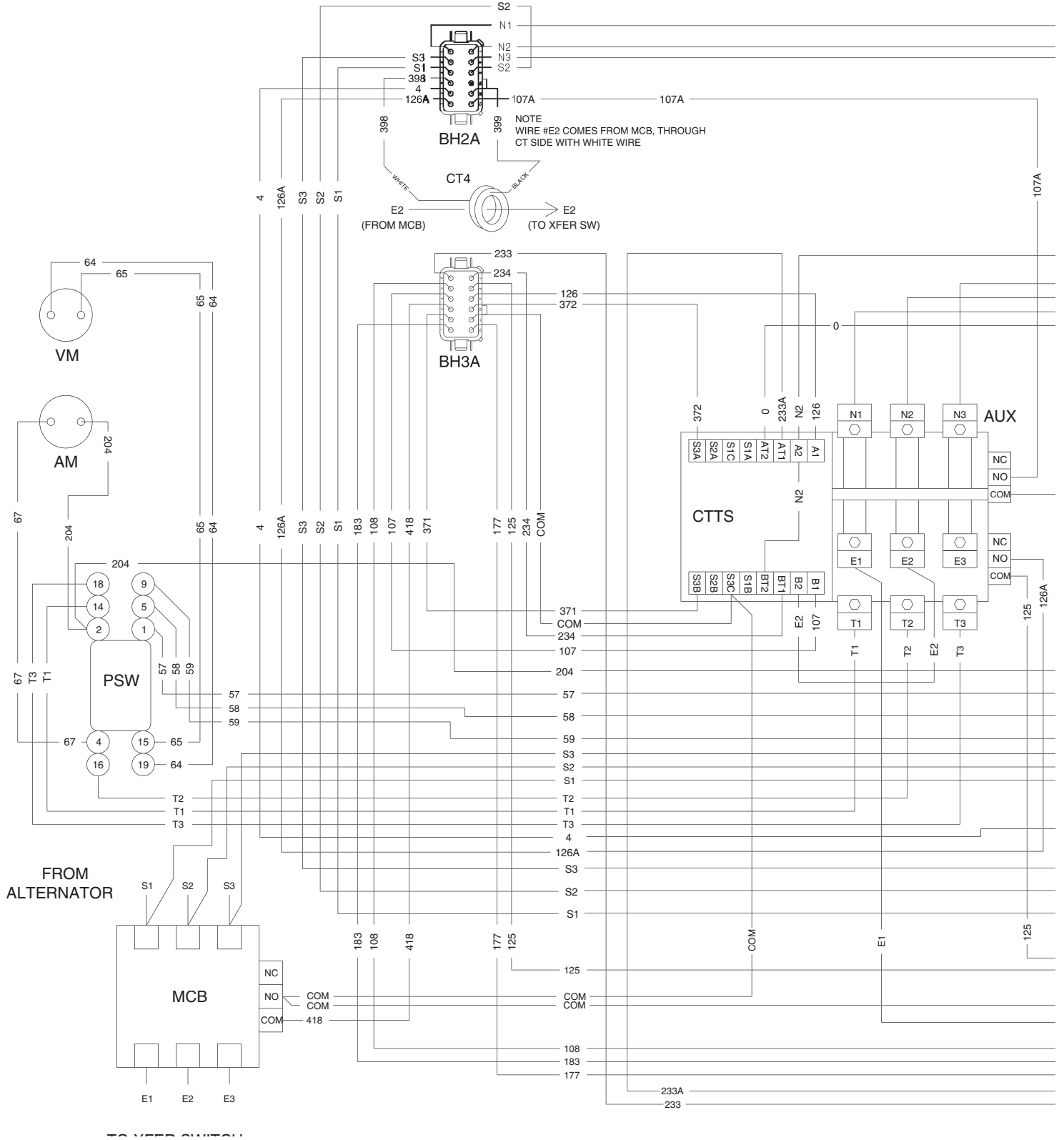

Section 6 – Electrical Data

DG 50 Generator Set Wiring Diagram (120/208V Connection Box) – Drawing No. 0C7703-C

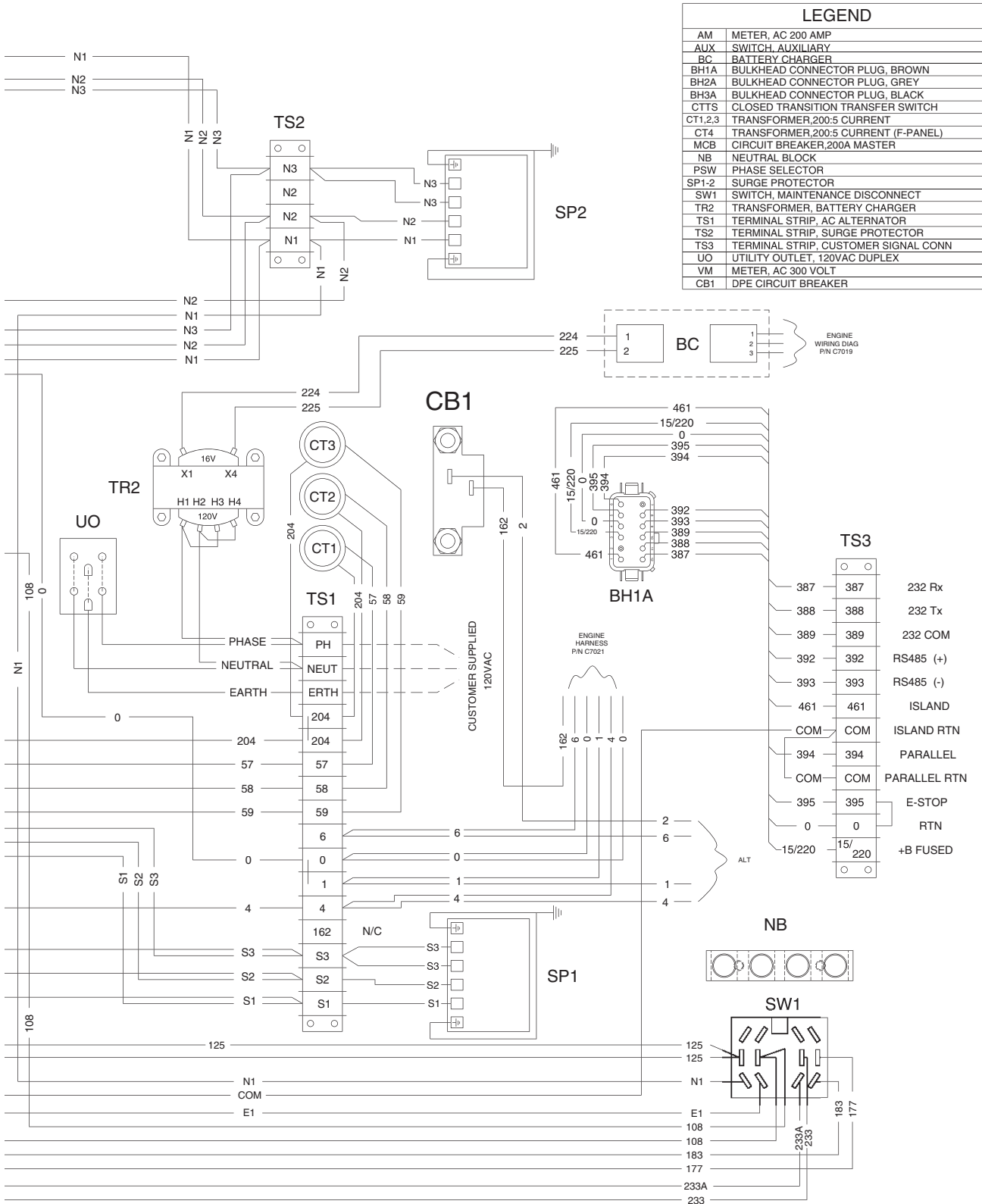
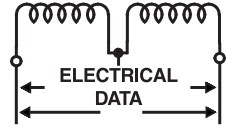

LEGEND

AM	METER, AC 200 AMP
AUX	SWITCH, AUXILIARY
BC	BATTERY CHARGER
BH1A	BULKHEAD CONNECTOR PLUG, BROWN
BH2A	BULKHEAD CONNECTOR PLUG, GREY
BH3A	BULKHEAD CONNECTOR PLUG, BLACK
CTTS	CLOSED TRANSITION TRANSFER SWITCH
CT1,2,3	TRANSFORMER, 200:5 CURRENT
CT4	TRANSFORMER, 200:5 CURRENT (F-PANEL)
MCB	CIRCUIT BREAKER, 200A MASTER
NB	NEUTRAL BLOCK
PSW	PHASE SELECTOR
SP1-2	SURGE PROTECTOR
SW1	SWITCH, MAINTENANCE DISCONNECT
TR2	TRANSFORMER, BATTERY CHARGER
TS1	TERMINAL STRIP, AC ALTERNATOR
TS2	TERMINAL STRIP, SURGE PROTECTOR
TS3	TERMINAL STRIP, CUSTOMER SIGNAL CONN
UO	UTILITY OUTLET, 120VAC DUPLEX
VM	METER, AC 300 VOLT
CB1	DPE CIRCUIT BREAKER

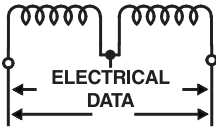

Section 6 – Electrical Data

DG 50 Generator Set

Wiring Diagram (480/277V Connection Box) – Drawing No. 0C5172-C

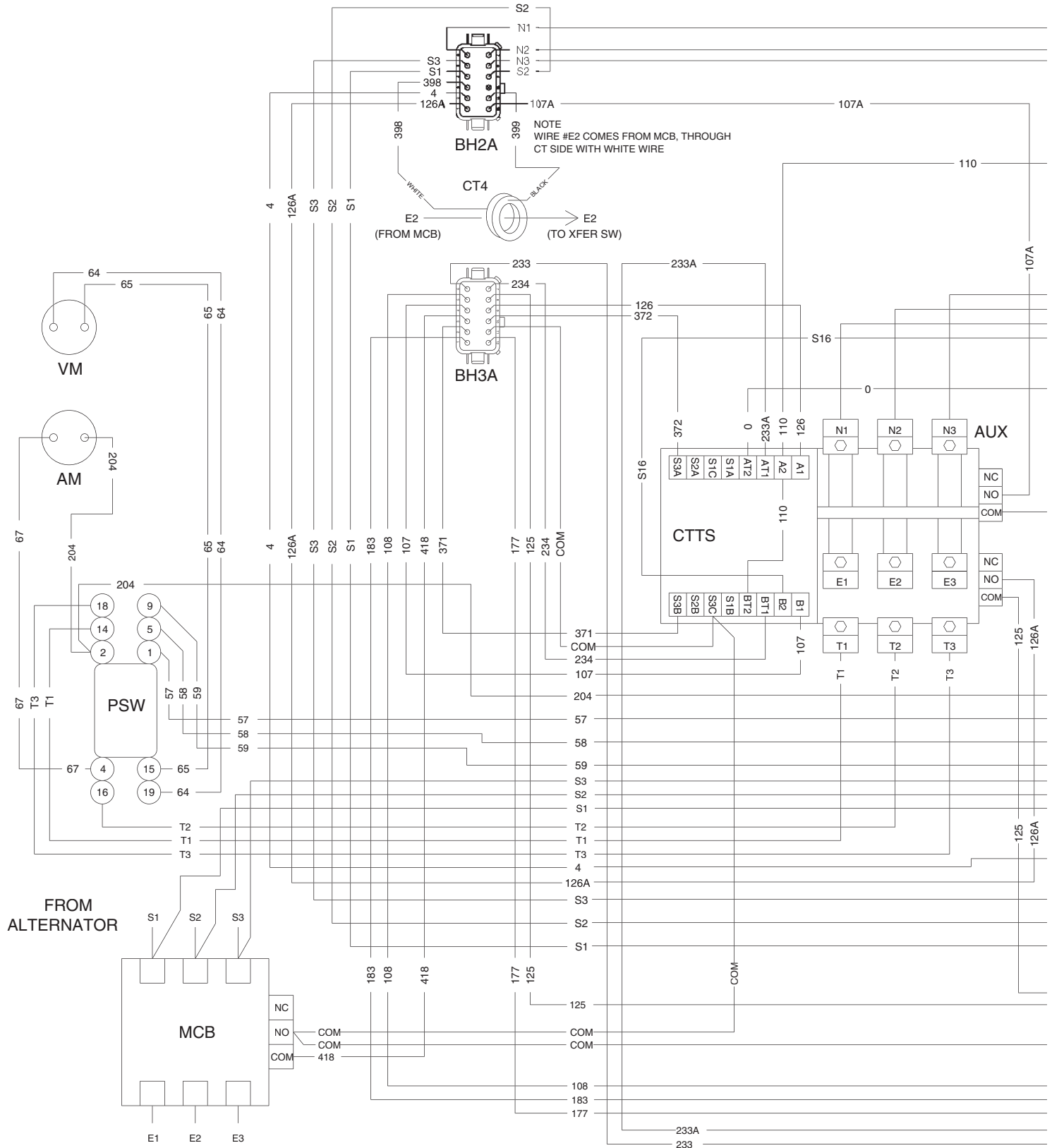

Section 6 – Electrical Data

DG 50 Generator Set
Wiring Diagram (480/277V Connection Box) – Drawing No. 0C5172-C

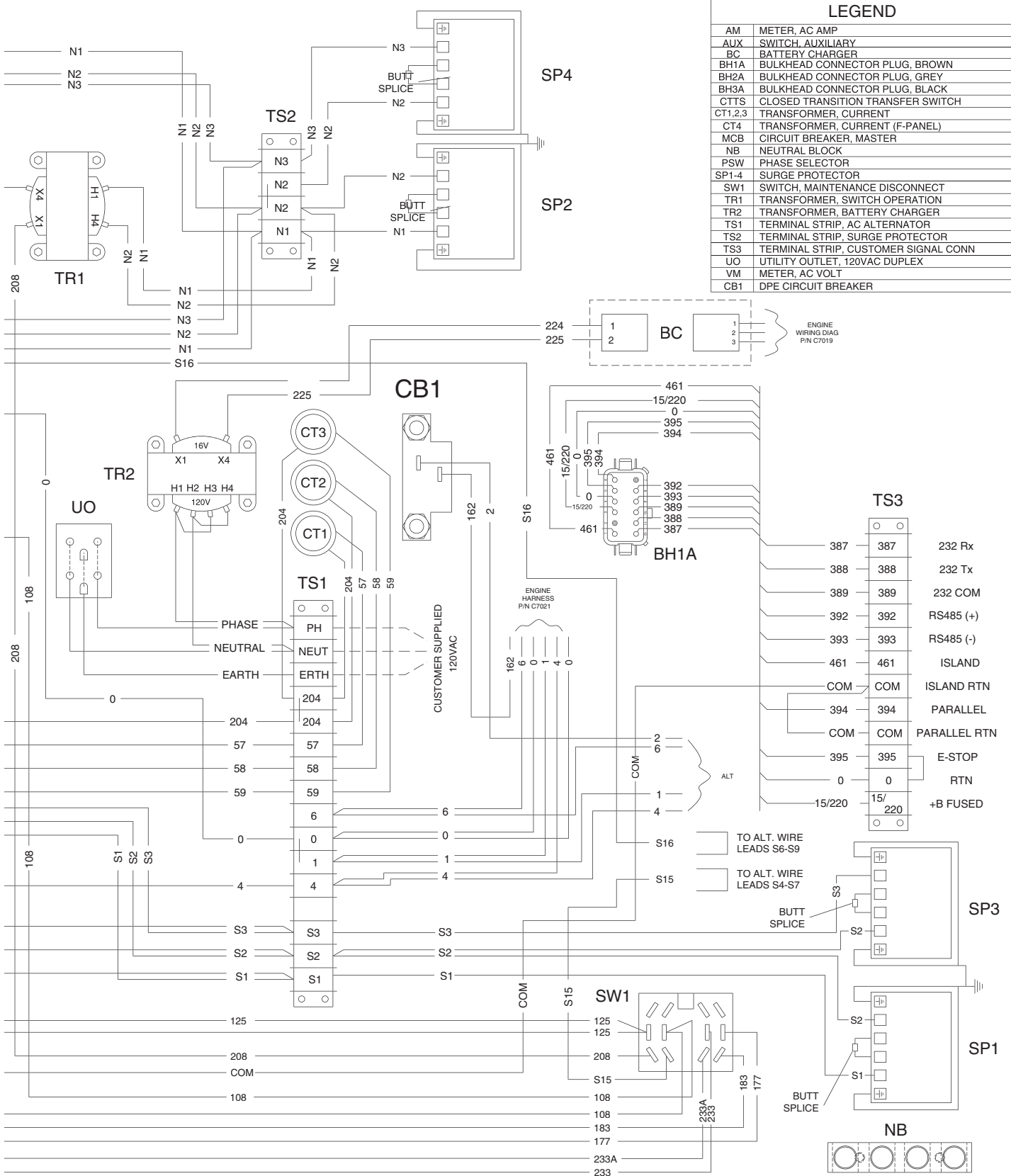
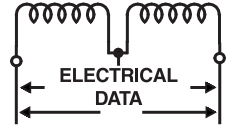

LEGEND	
AM	METER, AC AMP
AUX	SWITCH, AUXILIARY
BC	BATTERY CHARGER
BH1A	BULKHEAD CONNECTOR PLUG, BROWN
BH2A	BULKHEAD CONNECTOR PLUG, GREY
BH3A	BULKHEAD CONNECTOR PLUG, BLACK
CTTS	CLOSED TRANSITION TRANSFER SWITCH
CT1,2,3	TRANSFORMER, CURRENT
CT4	TRANSFORMER, CURRENT (F-PANEL)
MCB	CIRCUIT BREAKER, MASTER
NB	NEUTRAL BLOCK
PSW	PHASE SELECTOR
SP1-4	SURGE PROTECTOR
SW1	SWITCH, MAINTENANCE DISCONNECT
TR1	TRANSFORMER, SWITCH OPERATION
TR2	TRANSFORMER, BATTERY CHARGER
TS1	TERMINAL STRIP, AC ALTERNATOR
TS2	TERMINAL STRIP, SURGE PROTECTOR
TS3	TERMINAL STRIP, CUSTOMER SIGNAL CONN
UO	UTILITY OUTLET, 120VAC DUPLEX
VM	METER, AC VOLT
CB1	DPE CIRCUIT BREAKER

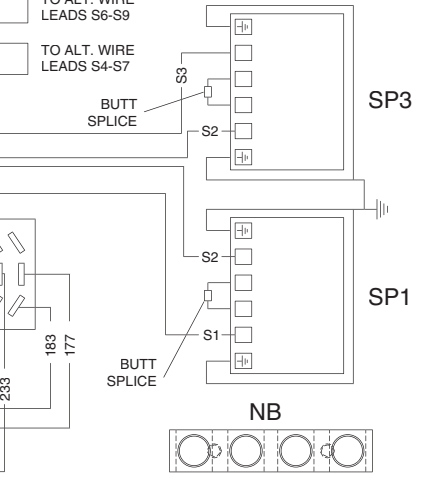
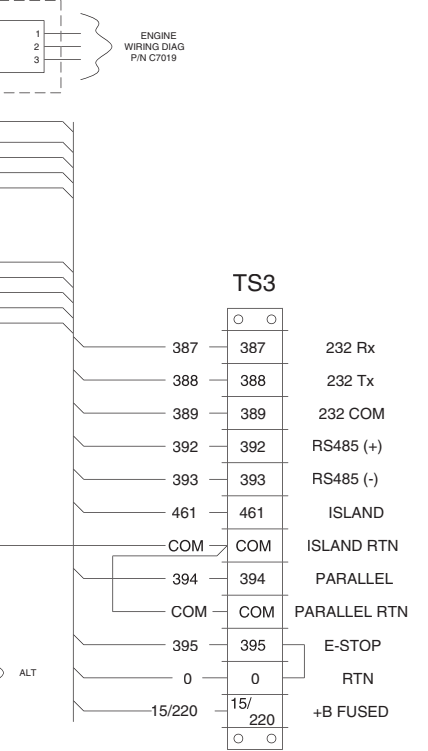

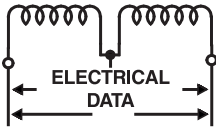

Section 6 – Electrical Data

DG 50 Generator Set Wiring Diagram (Engine, F-Panel) – Drawing No. 0C7019-B

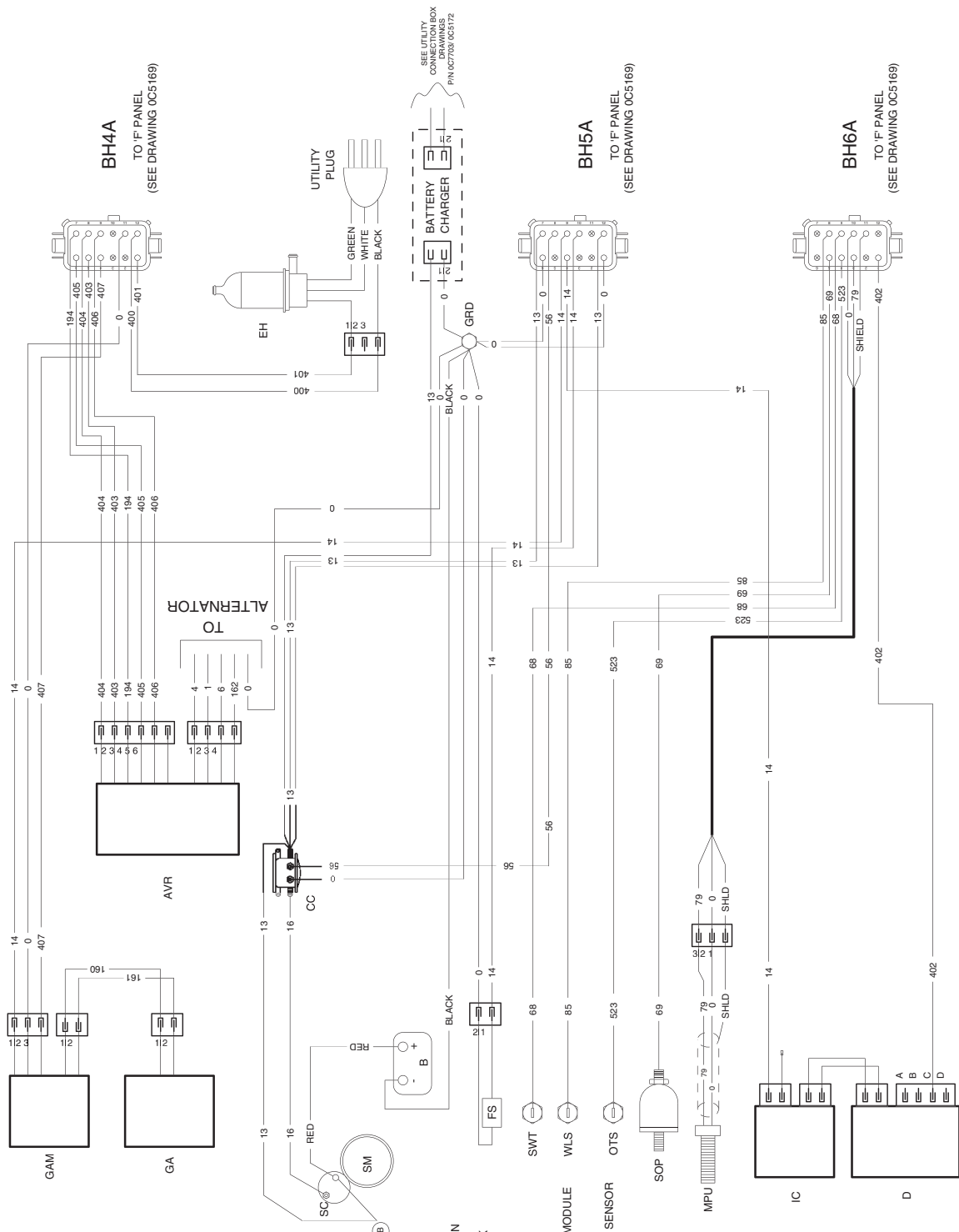

LEGEND

- AVR - AVR POWER MODULE
- B - BATTERY
- BH4A - BUI K/HEAD PLUG, BROWN
- BH5A - BUI K/HEAD PLUG, GRAY
- BH6A - BUI K/HEAD PLUG, BLACK
- CC - CONTROL CONTACTOR
- D - DISTRIBUTOR
- EH - ENGINE HEATER
- FS - FUEL SOLENOID
- GA - GOVERNOR ACTUATOR
- GAM - GOVERNOR ACTUATOR MODULE
- GRD - ENGINE GROUND
- IC - IGNITION COIL
- MPU - MAGNETIC PICK-UP/RPM SENSOR
- OTS - HIGH OIL TEMP SWITCH
- SC - STARTER CONTACTOR
- SM - STARTER MOTOR
- SOP - SENDER, OIL PRESSURE
- SMT - SENDER, WATER TEMP.
- WLS - WATER LEVEL SENSOR

Section 7 – Exploded Views and Parts Lists

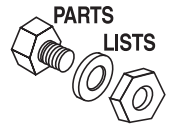

DG 50 Generator Set F Panel Relay Board Assembly (480/277V) – Drawing No. 0C5798-M

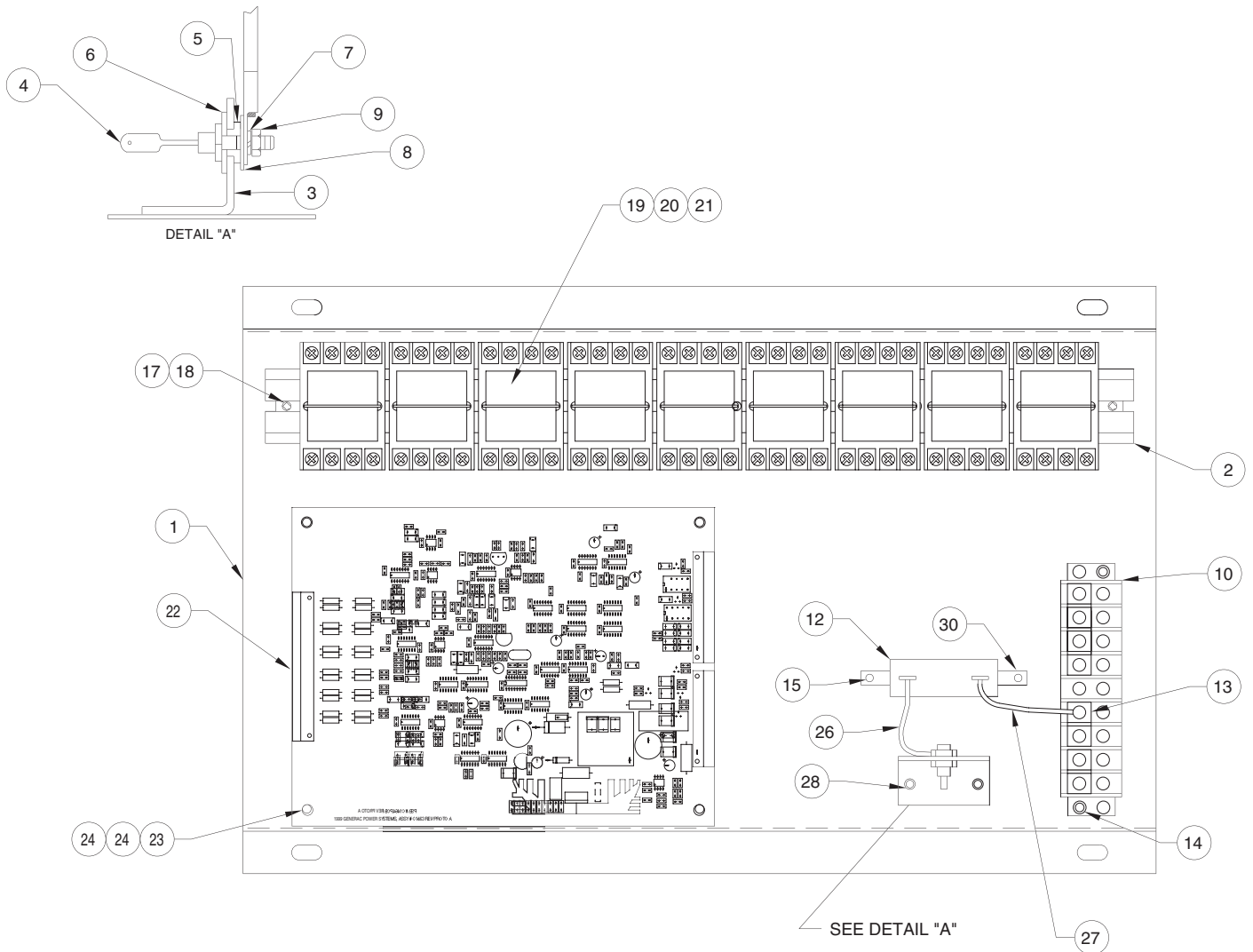

ITEM	PART NO.	QTY.	DESCRIPTION	ITEM	PART NO.	QTY.	DESCRIPTION
1	0C5797	1	RELAY SUBPLATE F-PNL	18	0C3990	2	SCREW TAPTITE PH M4-0.7 X 10 ZYC
2	0C5846	1	RAIL DIN 410MM	19	0C3211E	9	RELAY PNL 12VDC DPDT 8PIN
3	055444	1	HEATSINK	20	0C3211G	REF	SOCKET RELAY 8 PIN
4	049939	1	RECTIFIER MSC 12A 600V 1N1206R	21	0C3211H	8	SPRING RETAINING RELAY
5	030468	1	WASHER STEP NYLON .20	22	0C1463	1	RELAY PRTCTR 480V 30.1K
6	070370	1	WASHER MICA .203	23	064525	4	STANDOFF HEX 3/4
7	023762	1	WASHER SHAKEPROOF EXT #10 STL	24	064526	8	SCREW TAP HWH #6-25 X 3/8 ZINC
8	023897	1	WASHER FLAT #10 ZINC	25	0C5171	1	HARNESS 50KW UTIL F-PNL C-PNL (NOT SHOWN)
9	022158	1	NUT HEX #10-32 STEEL	26	0536210199	1	ASSY GROUND WIRE #29 D1-R1
10	061520	REF	BLOCK TERM 20A 9 X 6 X 1100V	27	0536210202	1	ASSY GROUND WIRE #14 TS-R1
12	057405	1	RES 25R 5% 25W	28	045764	2	SCREW TAPTITE M4-0.7 X 8 BP
13	046669	REF	BLOCK TERM JUMPER FOR S141	30	064733	2	RESISTOR MNTNG BRACKET FOR 25W
14	0A1661	2	RIVET POP .156 X .160-.164/#20				
15	036261	2	RIVET POP .125 X .129-.133/#30				
17	022264	2	WASHER LOCK M4				



Section 7 – Exploded Views and Parts Lists

DG 50 Generator Set

Relay Board Assembly (120/208V) – Drawing No. 0C9577-D

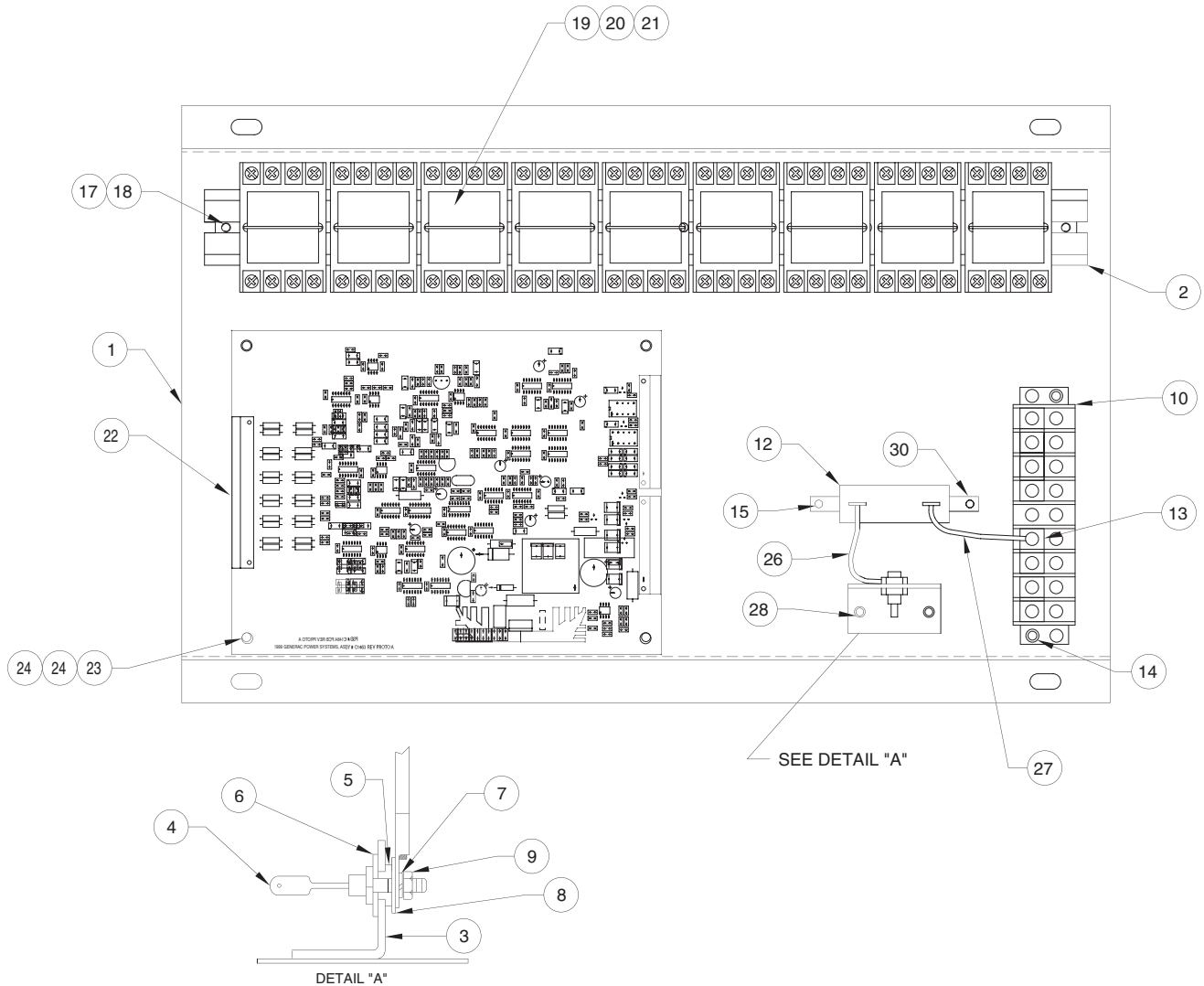

ITEM	PART NO.	QTY.	DESCRIPTION	ITEM	PART NO.	QTY.	DESCRIPTION
1	0C5797	1	RELAY SUBPLATE F-PNL	17	022264	2	WASHER LOCK #8-M4
2	0C5846	1	DIN RAIL 410MM	18	0C3990	2	SCREW PHTT M4-0.7 X 10 ZYC
3	055444	1	HEATSINK	19	0C3211E	9	RELAY PNL 12VDC DPDT 8PIN
4	049939	1	RECTIFIER MSC 12A 600V 1N1206R	20	0C3211G	REF.	SOCKET RELAY 8 PIN
5	030468	1	WASHER STEP NYLON .20	21	0C3211H	8	SPRING RELAY RETAINING
6	070370	1	WASHER MICA .203	22	0C1463A	1	RLYPRTCTR 208V 69.8K
7	023762	1	WASHER SHAKEPROOF EXT #10 STL	23	064525	4	STANDOFF HEX 3/4
8	023897	1	WASHER FLAT #10 ZINC	24	064526	8	SCREW S-THR PH #6-25 X 3/8 ZNC
9	022158	1	NUT HEX #10-32 STEEL	25	0C5171	1	HARNESS 50KW UTL F-PNL C- PNL
10	061520	REF.	BLOCK TERM 20A 9 X 6 X 1100V	26	0536210199	1	WIRE ASS'Y-#29: D1-R1
12	057405	1	RES 25R 5% 25W	27	0536210202	1	WIRE ASS'Y-#14 TS-R1
13	046669	REF.	BLOCK TERM JUMPER	28	045764	2	SCREW HHTT M4-0.7 X 8 BP
14	0A1661	2	RIVET POP .156 X .675 AL	30	064733	2	RES MTG BRACKET
15	036261	2	RIVET POP .125 X .275 AL				

Section 7 – Exploded Views and Parts Lists

DG 50 Generator Set
F Panel Assembly (120/208V) – Drawing No. 0C9578-A

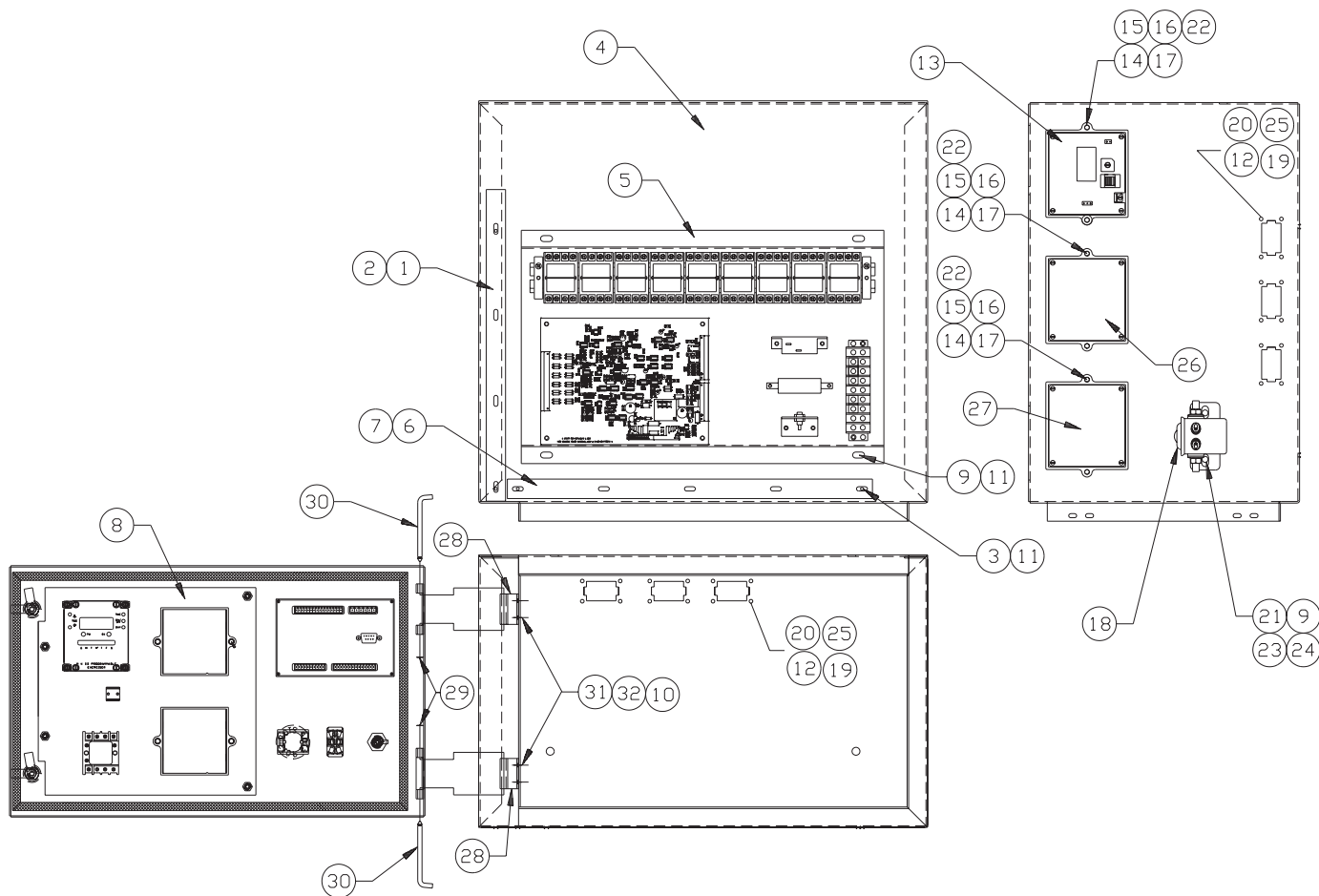

ITEM	PART NO.	QTY.	DESCRIPTION	ITEM	PART NO.	QTY.	DESCRIPTION
1	0C3988	1	BASE WIRE DUCT 1	16	051713	12	WASHER FLAT M5
2	0C3988A	1	COVER WIRE DUCT 1	17	049226	6	WASHER LOCK M5
3	0C3990	4	SCREW TAPTITE PH M4-0.7X10 ZYC	18	056739	1	RELAY SOLENOID 12VDC PNL MNT
4	0C5794	1	WELDMENT,C-PNL TOP	19	022188	24	NUT HEX #6-32 STEEL
5	0C9577	1	ASSY 208 RELAY BOARD	20	022155	24	WASHER LOCK #6
6	0C5925	1	DUCT WIRE F-PNL	21	022473	2	WASHER FLAT 1/4 ZINC
7	0C5925A	1	DUCT WIRE COVER F-PNL	22	051716	6	NUT HEX M5-0.8 G8 YEL CHR
8	0C6032	1	ASSY DOOR F-PNL	23	049813	2	NUT HEX M6 -1.0 G8 YEL CHR
9	022097	6	WASHER LOCK M6-1/4	24	049815	2	SCREW HHC M5-0.8 X 16 G8.8
10	022264	8	WASHER LOCK M4	25	036902	24	SCREW PPHM #6-32 X 1/2
11	045756	4	SCREW TAPTITE M6X10 YEL CHR	26	0C6947	1	ASSY GOV ACT MOD
12	0C5141	6	GASKET CONN BLKHD	27	0C2846	1	MODULE POWER AVR F-PNL
13	0A1801	1	ASSY BATTERY CHARGER ENGINE	28	0C5719	2	HINGE FASTENED HALF
14	029187	6	SPACER .19 X .31 X .50 STL/ZNC	29	0C5721	2	RING SNAP HINGE
15	052762	6	SCREW HHC M5-0.8 X 45 G8.8	30	0C5722	2	PIN HINGE
				31	043180	4	WASHER FLAT M4

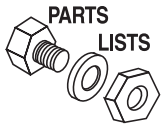

Section 7 – Exploded Views and Parts Lists

DG 50 Generator Set

F Panel Box Assembly (480/277V) – Drawing No. 0C5946-G

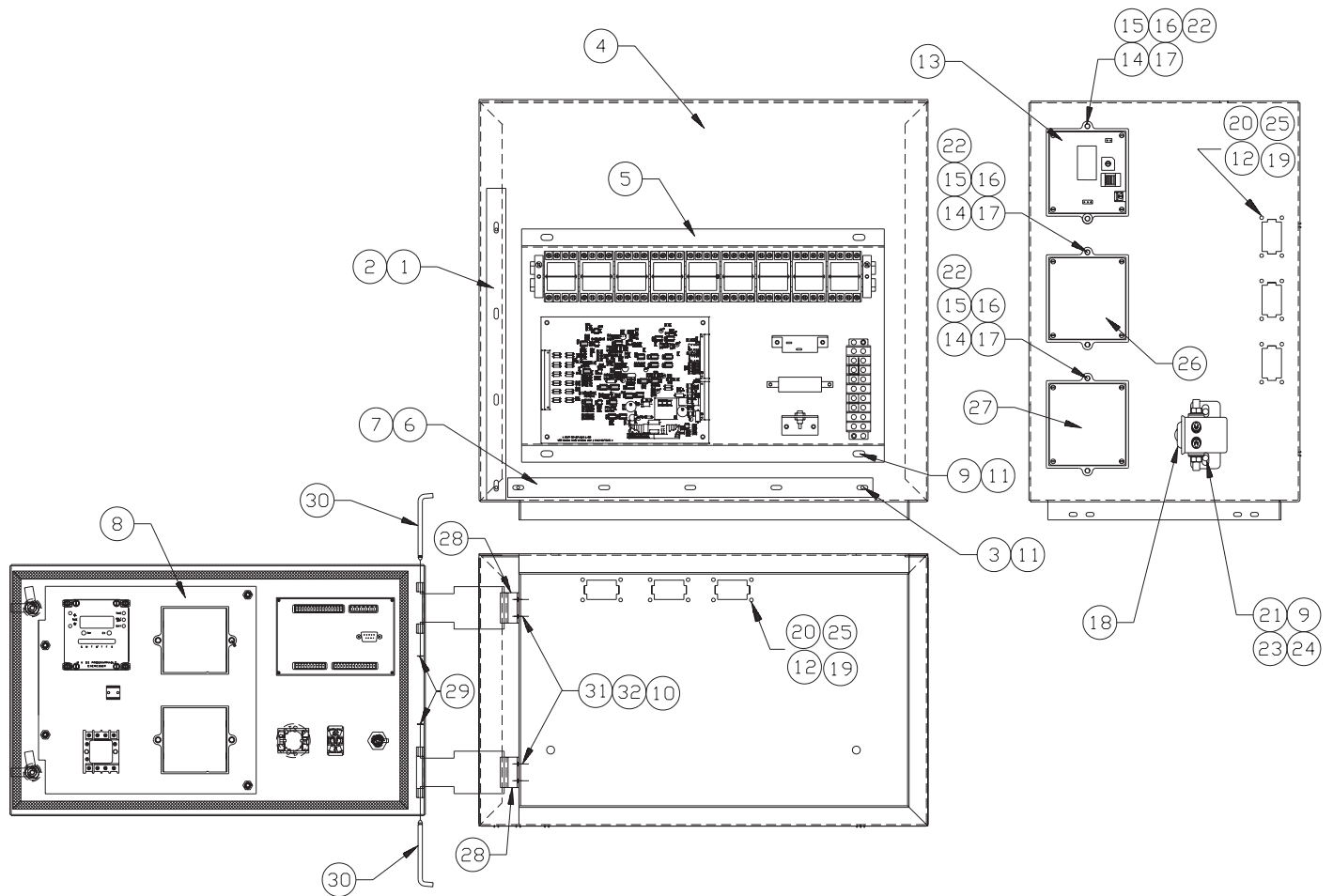

ITEM	PART NO.	QTY.	DESCRIPTION	ITEM	PART NO.	QTY.	DESCRIPTION
1	0C3988	1	BASE WIRE DUCT 1	16	051713	12	WASHER FLAT M5
2	0C3988A	1	COVER WIRE DUCT 1	17	049226	6	WASHER LOCK M5
3	0C3990	4	SCREW TAPTITE PH M4-0.7X10 ZYC	18	056739	1	RELAY SOLENOID 12VDC PNL MNT
4	0C5794	1	WELDMENT,C-PNL TOP	19	022188	24	NUT HEX #6-32 STEEL
5	0C5798	1	ASSY RELAY BOARD TO F-PANEL	20	022155	24	WASHER LOCK #6
6	0C5925	1	DUCT WIRE F-PNL	21	022473	2	WASHER FLAT 1/4 ZINC
7	0C5925A	1	DUCT WIRE COVER F-PNL	22	051716	6	NUT HEX M5-0.8 G8 YEL CHR
8	0C6032	1	ASSY DOOR F-PNL	23	049813	2	NUT HEX M6 -1.0 G8 YEL CHR
9	022097	6	WASHER LOCK M6-1/4	24	049815	2	SCREW HHC M5-0.8 X 16 G8.8
10	022264	8	WASHER LOCK M4	25	036902	24	SCREW PPHM #6-32 X 1/2
11	045756	4	SCREW TAPTITE M6-1X10 YEL CHR	26	0C6947	1	ASSY GOV ACT MOD
12	0C5141	6	GASKET CONN BLKHD	27	0C2846	1	MODULE POWER AVR F-PNL
13	0A1801	1	ASSY BATTERY CHARGER ENGINE	28	0C5719	2	HINGE FASTENED HALF
14	029187	6	SPACER .19 X .31 X .50 STL/ZNC	29	0C5721	2	RING SNAP HINGE
15	052762	1	SCREW HHC M5-0.8 X 45 G8.8	30	0C5722	2	PIN HINGE
				31	043180	4	WASHER FLAT M4
				32	049819	4	SCREW HHC M4-0.7 X 6 G8.8

Section 7 – Exploded Views and Parts Lists

**DG 50 Generator Set
DG 50 Oil Pump Kit – Drawing No. 0C8541-D**

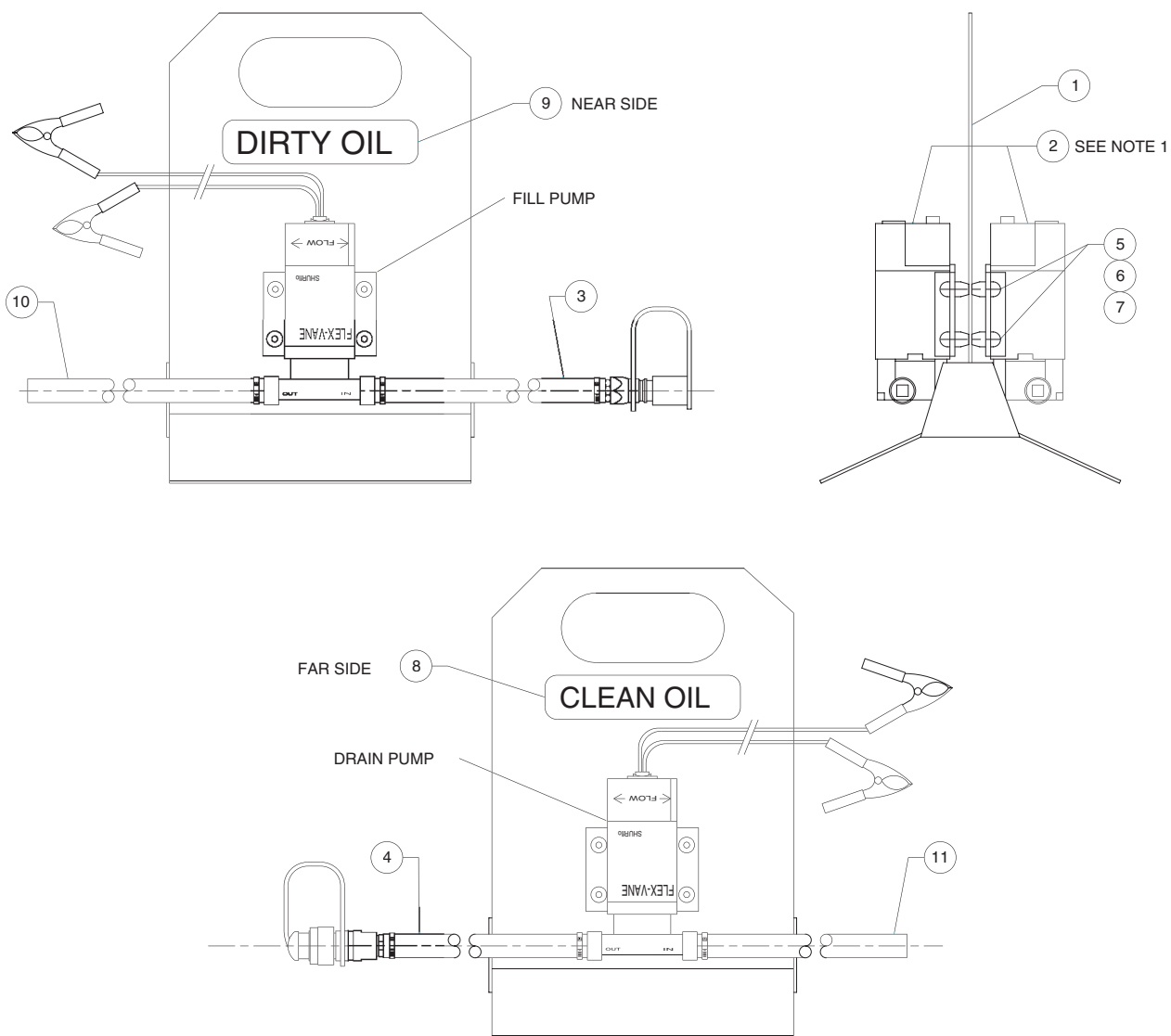
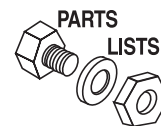

NOTE:

1. INCLUDE INSTALLATION AND OPERATION MANUAL WITH FLEX VANE PROPELLER PUMP.

ITEM	PART NO.	QTY.	DESCRIPTION
1	0D2593	1	MOUNT OIL SERVICE PUMP
2	0C8550	2	PUMP OIL TRANSFER
3	0D2600	1	ASSY HOSE DRAIN PUMP INLET
4	0D2601	1	ASSY HOSE FILL PUMP DISCHARGE
5	0C7605	4	SCREW HHC M5-0.8 X 60 G8.8
6	023897	4	WASHER FLAT #10 ZINC
7	082025	4	NUT LOCK HEX M5-0.8 SS NYL INS
8	0D2802	1	DECAL CLEAN OIL
9	0D2801	1	DECAL DIRTY OIL
10	0D2597	1	ASSY HOSE DRAIN PUMP DISCHARGE
11	0D2599	1	ASSY HOSE FILL PUMP INLET
12	0D2602	1	ADAPTER DRAIN PUMP SUMP (NOT SHOWN)

Section 7 – Exploded Views and Parts Lists

**DG 50 Generator Set
F Panel Door Assembly – Drawing No. 0C6032-N**

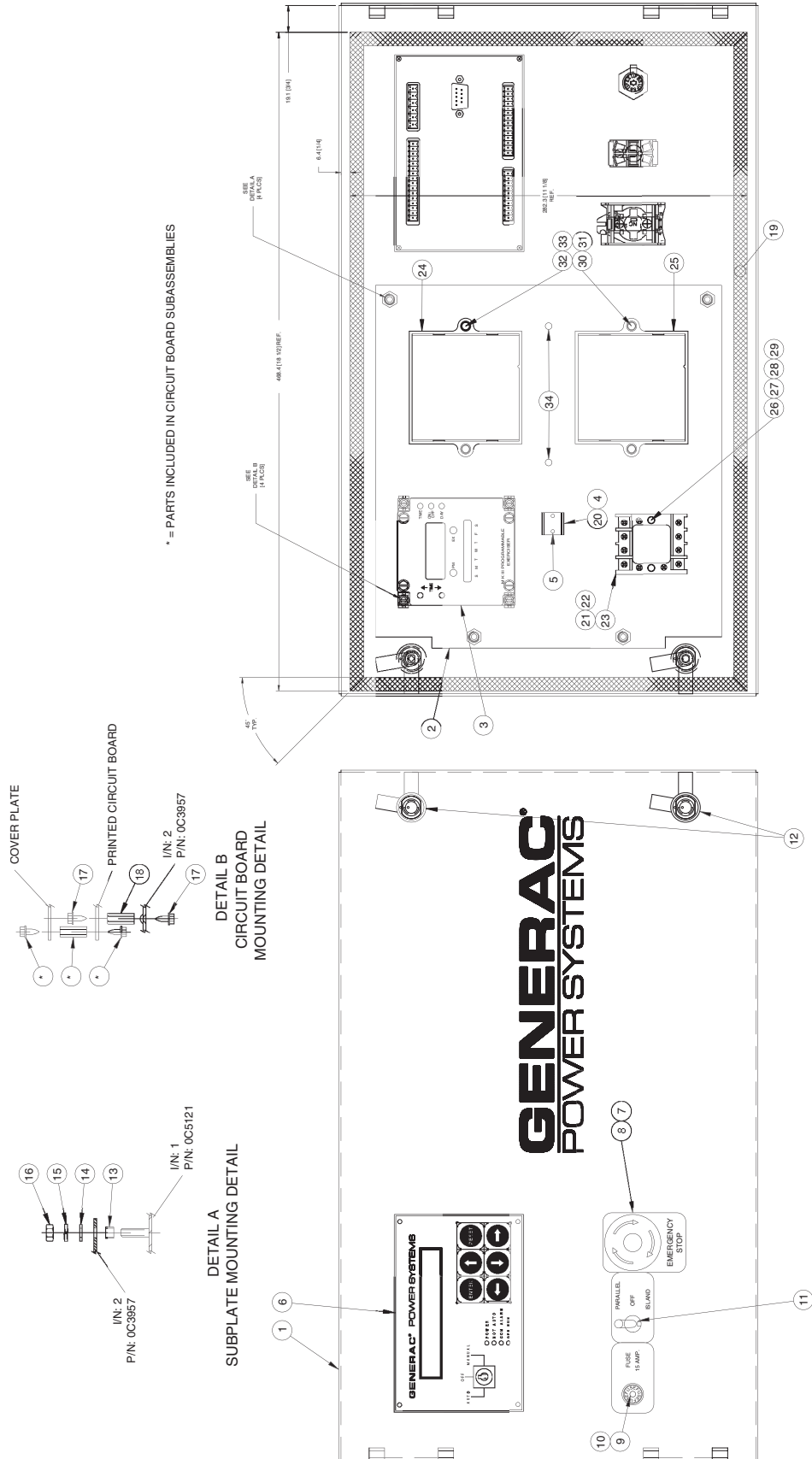

Section 7 – Exploded Views and Parts Lists

DG 50 Generator Set F Panel Door Assembly – Drawing No. 0C6032-N



ITEM	PART NO.	QTY.	DESCRIPTION
1	0C6036	1	DOOR W \ SILKSCREEN
2	0C6033	1	SUB-PLATE DOOR
3	0A8637	1	ASSY MK3 EXERCISER
4	063982	1	BATT CLIP-9V TRANSIS
5	029357	2	RIVET AVDEL3/32 X 1/8L
6	0C5784	1	ASSY F-PANEL
7	0E2693A	1	SWITCH MUSHRM HEAD/ARROWS 40MM
8	0E2693C	1	CONTACT BLOCK D5-3 X 01 W/2 1417
9	032300	1	HOLDER FUSE
10	022676	1	FUSE 15A X AGC15
11	061694	REF	SWITCH TOG SPDT 6A SPD CTR OFF
12	020825	2	LATCH VICE ACTION
13	038198	4	SPACER .28 X .62 X .25 STL/ZNC
14	022473	4	WASHER FLAT 1/4 ZINC
15	022097	4	WASHER LOCK M6-1/4
16	049813	4	NUT HEX M6 -1.0 G8 YEL CHR
17	064526	8	SCREW S-THR PH #6-25 X 3/8 ZNC
18	064525	4	STANDOFF HEX 3/4
19	0C5123	1	SEAL DOOR 3/8" X 1/4" (29")
20	063998	1	BATTERY 9V
21	0C3211L	REF	SOCKET RELAY 11 PIN
22	0C3211K	1	RELAY 12VDC 3PDT
23	0C3211H	2	SPRING RELAY RETAINING
24	0C6860	1	OVERSPEED MOD 50 PCB
25	0C7013	1	ASSY WATCHDOG 50KW
26	084932	2	SCREW HHC M4-0.7 X 30 G8.8
27	022264	2	WASHER LOCK M4
28	038150	2	WASHER FLAT #8 ZINC
29	051715	2	NUT HEX M4-0.7 G8 YEL CHR
30	049226	4	WASHER LOCK M5
31	051713	4	WASHER FLAT M5
32	051716	4	NUT HEX M5-0.8 G8 YEL CHR
33	055440	4	SCREW HHC M5-0.8 X 25 G8.8
34	063378	2	HOLDER CABLE TIE (NOT SHOWN)

Section 7 – Exploded Views and Parts Lists

DG 50 Generator Set

120/208 Volt Connection Box – Drawing No. 0D8949-A

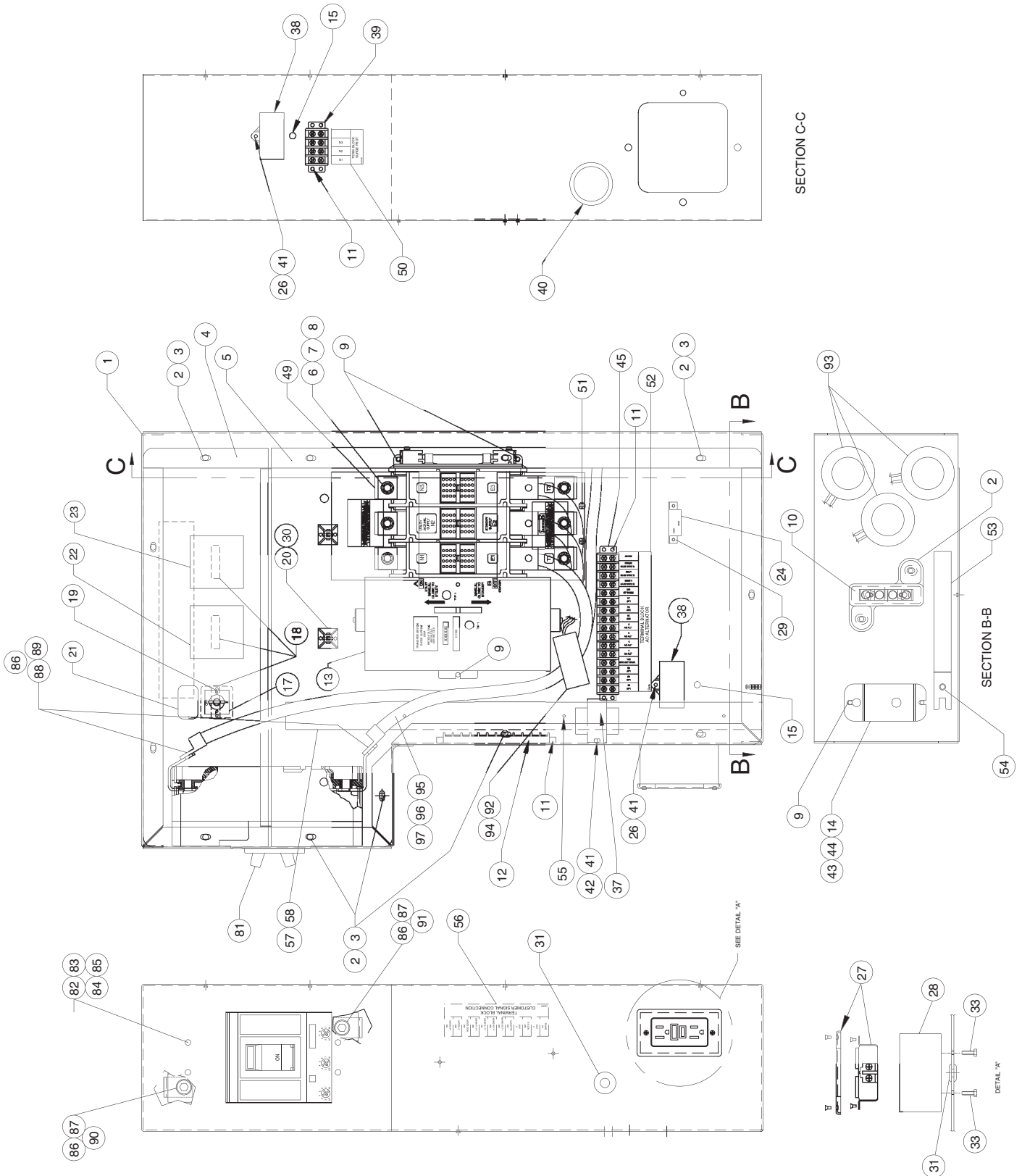

Section 7 – Exploded Views and Parts Lists

DG 50 Generator Set 120/208 Volt Connection Box – Drawing No. 0D8949-A

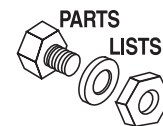

ITEM	PART NO.	QTY.	DESCRIPTION	ITEM	PART NO.	QTY.	DESCRIPTION
1	0C4903C	1	WELDMENT CONN BOX DG50 120/208	40	036654	1	GROMMET 1-3/4 X 1/16 X 1-1/2
2	090388	14	SCREW TAPTITE M6-1.0 X 12 BP	41	022264	4	WASHER LOCK M4
3	0A2115	12	WASHER NYLON .250	42	0A1495	2	SCREW TAPTITE M4-0.7 X 10 BP
4	0C5061	1	COVER CONN BOX TOP	43	063897	1	BRKT SUPT AIR CLNR
5	0C4969	1	COVER PLATE CONN BOX	44	055868	REF	SWITCH TOGGLE 4PDT 15A SPADE
6	0A9949	9	LUG SLDLSS 400-#4 X 1/4-20 CU7AL	45	043365	REF	BLOCK TERM 20A 16 X 6 X 1100V
7	0C4896	9	SCREW FHMS M8-1.25 X 20MM CR	46	0C7907D	2	COVER LUG 3P 150 / 200AMP
8	067989	9	NUT LOCK FL M8-1.25 YEL CHR	47	0C8275	4	SCREW PPHM DSEMS M4-7 X 10 ZINC
9	074908	5	SCREW TAPTITE M5-0.8 X 10 BP	48	0C8308	2	DECAL TERMINAL SHOCK HAZARD
10	0C4449	1	ASSEMBLY NEUTRAL BLOCK 100A	49	026902	3	SCREW TAPTITE #8-32 X 1/4 BP
11	0A1661	6	RIVET POP .156 X .160-.164/#20	50	0C8063	1	DECAL-UTIL SRG PRO#2
12	055911	REF	BLOCK TERM 20A 12 X 6 X 1100V	51	063378	2	HOLDER CABLE TIE
13	0D4265	1	CTTS SW-200A 600V3P DC UTL TRIP	52	0C8062	1	DECAL-UTIL ALT CONN
14	063989	1	BRACKET TOGGLE SWITCH	53	063321	REF	HANDLE TRANSFER SW 1-400A
15	045756	2	SCREW TAPTITE M6-1 X 10 YEL CHR	54	087680	1	NUT WING M6-1.0
17	074386	1	SWITCH SELECTOR VOLT/AMP 3PH	55	091477	3	RIVET WIRE DUCT MNT
18	0C4895	3	DECAL SHOCK HAZARD	56	0E3436	1	DECAL, CUSTOMER SIGNAL CONNS
19	0C4979	2	SCREW TAP HWH #8-25 X 3/8 ZINC	57	091472	2 FT	DUCT WIRING 1 X 1.5 6 FT
20	028739A	2	TIE WRAP 3.9" X .10" BLK UL	58	091472A	2 FT	COVER WIRE DUCT 1 IN
21	0C2603	1	DECAL PH SELECT A/V	59	042419	4	SCREW RHM 10-32 X 4
22	070043	1	VOLTMETER AC 0-300	80	0D8950	REF	KIT CB DG50 S (3P/600V)120/208 PARTS LISTED BELOW (I/N 81-97)
23	070045	1	AMMETER AC 0-200	81	0D9098	1	ASSY CB DG50 S (3P/480V)/120/208
24	048476	1	CIRCT BRK 4.5 X 1 AUT30KW CNT45K	82	081320	4	SCREW SHC 1/4-20 X 4.5 G8.8 NZ
25	0C7360	1	CONNPNL HARN 208 /120 (NOT SHOWN)	83	022473	8	WASHER FLAT 1/4 ZINC
26	0C3992	2	SCREW TAPTITE M4-0.7 X 16 BP	84	022097	4	WASHER LOCK M6-1/4
27	080409	1	RECEP DUPLEX GFCI20A	85	022127	4	NUT HEX 1/4-20 STEEL
28	0D2759	1	GFCI BOX WEATHER PROOF	86	022237	12	WASHER LOCK 3/8
29	0C2428	2	SCREW PHTT #6-32 X 1/2 ZYC	87	048527	6	SCREW SHC 3/8-16 X 3/4 G8.8 NZ
30	057593	2	MOUNT TIE CABLE BLACK	88	022241	6	NUT HEX 3/8-16 STEEL
31	089685	2	GROMMET .75 X .12 X .50	89	023152	6	SCREW HHC 3/8-16 X 3/4 G5
33	045756	2	SCREW TAPTITE M6-1 X 10 YEL CHR	90	0D8935A	3	BUS BAR CB DG50 (120/208) LINE
34	023152	3	SCREW HHC 3/8-16 X 3/4 G5	91	0D8935	3	BUS BAR CB DG50 (120/208) LOAD
35	022241	3	NUT HEX 3/8-16 STEEL	92	0C8103	1	CT ASSY 200/5A 2.5VA W#6SPADE
36	022237	3	WASHER LOCK 3/8	93	0C8104	3	CT ASSY 200/5A 2.5VA W/FASTON
37	0C8105	1	ASSY 56VA TRANSFORMER	94	029333A	1	TIE WRAP UL 7.4" X .19" BLK
38	0C8102A	2	ASSEMBLY SURGE PROTECTOR	95	0536210221	1	WIRE LEAD ATS E1 TO CB DG50120
39	046689	REF	BLOCK TERM 20A 4 X 6 X 1100V	96	0536210222	1	WIRE LEAD ATS E2 TO CB DG50120
				97	0536210223	1	WIRE LEAD ATS E3 TO CB DG50120

Section 7 – Exploded Views and Parts Lists

DG 50 Generator Set 480/277 Volt Control Panel – Drawing No. 0D8945-B

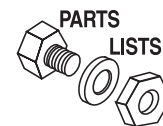

ITEM	PART NO.	QTY.	DESCRIPTION	ITEM	PART NO.	QTY.	DESCRIPTION
1	0C4903B	1	WELDMENT CONBOX DG50 277/480	41	022264	10	WASHER LOCK #8-M4
2	090388	14	SCREW HHTT M6-1.0 X 12 ZINC	42	0A1495	2	SCREW HHTT M4-0.7 X 10 BP
3	0A2115	12	WASHER NYLON .250	43	0C3992	4	SCREW HHTT M4-0.7 X 16 BP
4	0C5061	1	COVER CONN BOX TOP	44	043180	4	WASHER FLAT M4
5	0C4969	1	COVER PLATE CONN BOX	45	051715	4	NUT HEX M4-0.7 G8 YEL CHR
6	0A9949	9	LUG SLDLSS 400-#4 X 1/4-20 CU7AL	46	051787	4	SCREW HHC M4-0.7 X 16 G8.8
7	0C4896	9	SCREW FHMS M8-1.25 X 20MM CR	47	0C5174	1	HARNESS, CONTROL PANEL 480V BX (NOT SHOWN)
8	067989	9	NUT LOCK FL M8-1.25 YEL CHR	48	063987	1	DECAL-MAINTENANCE DISCONNECT
9	074908	5	SCREW HHTT M5-0.8 X 10 BP	49	055868	REF	SWITCH TOGGLE 4PDT 15A SPADE
10	0C4449	1	ASSY NEUTRAL BLOCK 100A	50	087680	1	NUT WING M6-1.0
11	0A1661	6	RIVET POP .156 X .675 AL	51	057593	2	CABLE TIE MOUNT BLACK
12	055911	REF	BLOCK TERM 20A 12 X 6 X 1100V	52	091477	3	RIVET WIRE DUCT MNT
13	0D4265	1	CTTS SW-200A600V3P DC UTL TRIP	53	091472	2 FT	DUCT WIRING 1 X 1.5 6 FT
14	063989	1	BRACKET TOGGLE SWITCH	54	091472A	2 FT	COVER WIRE DUCT 1 IN
15	0C2428	4	SCREW PHTT #6-32 X 1/2 ZYC	58	0C8062	1	DECAL UTIL ALT CONN
17	074386	1	SWITCH SELECT VOLT/AMP 3PH	59	0C8063	1	DECAL UTIL SRG PRO#2
18	0C4895	3	DECAL SHOCK HAZARD	60	0E3436	1	DECAL, CUSTOMER SIGNAL CONNS
19	0C4979	2	SCREW TAP HWH #8-25 X 3/8 ZINC	61	026902	3	SCREW HHTT #8-32 X 1/4 CZ
20	028739A	2	TIE WRAP 3.9" X .10" BLK UL	62	045771	3	NUT HEX M8-1.25 G8 YEL CHR
21	0C2603	1	DECAL PH SELECT A/V	80	0D8946	REF	KIT, CB DG50S (3P/480V) /277/480 (PARTS SHOWN BELOW, I/N 81-96)
22	070044	1	VOLTMETER AC 0-600	81	0D5569D	1	CB 0090A 3P 600V S ED6 AS
23	070048	1	AMMETER SCALE 0-100	82	066715	4	SCREW RHM #8-32 X 4-1/2
24	070045	1	AMMETER AC 0-200	83	038150	8	WASHER FLAT #8 ZINC
25	043365	REF	BLOCK TERM 20A 16 X 6 X 1100V	84	022264	4	WASHER LOCK #8-M4
26	064126	1	TRANSFRM 240/480V-120/240V	85	022471	4	NUT HEX #8-32 STEEL
27	080409	1	RECEP DUPLEX GFCI20A	86	0A8278	3	SCREW SHC 1/4-28 X 3/4 G8.8 NZ
28	0D2759	1	GFCI BOX WEATHER PROOF	87	022097	3	WASHER LOCK M6-1/4
29	048476	1	CIRCT BRK 4.5X1 AUT30KW CNT45K	88	0D5621	3	WASHER-STEP 1/2ODX9/32ID BRASS
30	0C8308	2	DECAL TERMINAL SHOCK HAZARD	89	0536210218	1	CB WIRE ASSY DG50 277/480 WHT
31	089685	2	GROMMET .75 X .12 X .50	90	0536210219	1	CB WIRE ASSY DG50 277/480 BLK
32	063321	REF	HANDLE XFER SWITCH 1- 400A	91	0C8216	3	CT ASSY 100/5A 2.5VA W#6 SPADE
33	045756	2	SCREW HHTT M6-1.0 X 10 YC	92	0C8217	1	CT ASSY 100A/5A 2.5VA W/FASTON
34	0C8275	4	SCREW PPHM DSEMS M4-7 X 10 ZNC	93	029333A	1	TIE WRAP UL 7.4"X .19" BLK
35	0C7907D	2	LUG COV3P 150/200AMP	94	0536210203	1	WIRE LEAD ATS E1 TO CB DG50277
36	063378	2	HOLDER CABLE TIE	95	0536210204	1	WIRE LEAD ATS E2 TO CB DG50277
37	0C8105	1	ASSY 56VA TRANSFORMER	96	0536210205	1	WIRE LEAD ATS E3 TO CB DG50277
38	0C8102	4	ASSY SURGE PROTECTOR				
39	046689	REF	BLOCK TERM 20A 4 X 6 X 1100V				
40	036654	1	GROMMET 1-3/4 X 1/16 X 1-1/2				

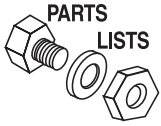

Section 7 – Exploded Views and Parts Lists

DG 50 Generator Set Mounting Base – Drawing No. 0C5714-H

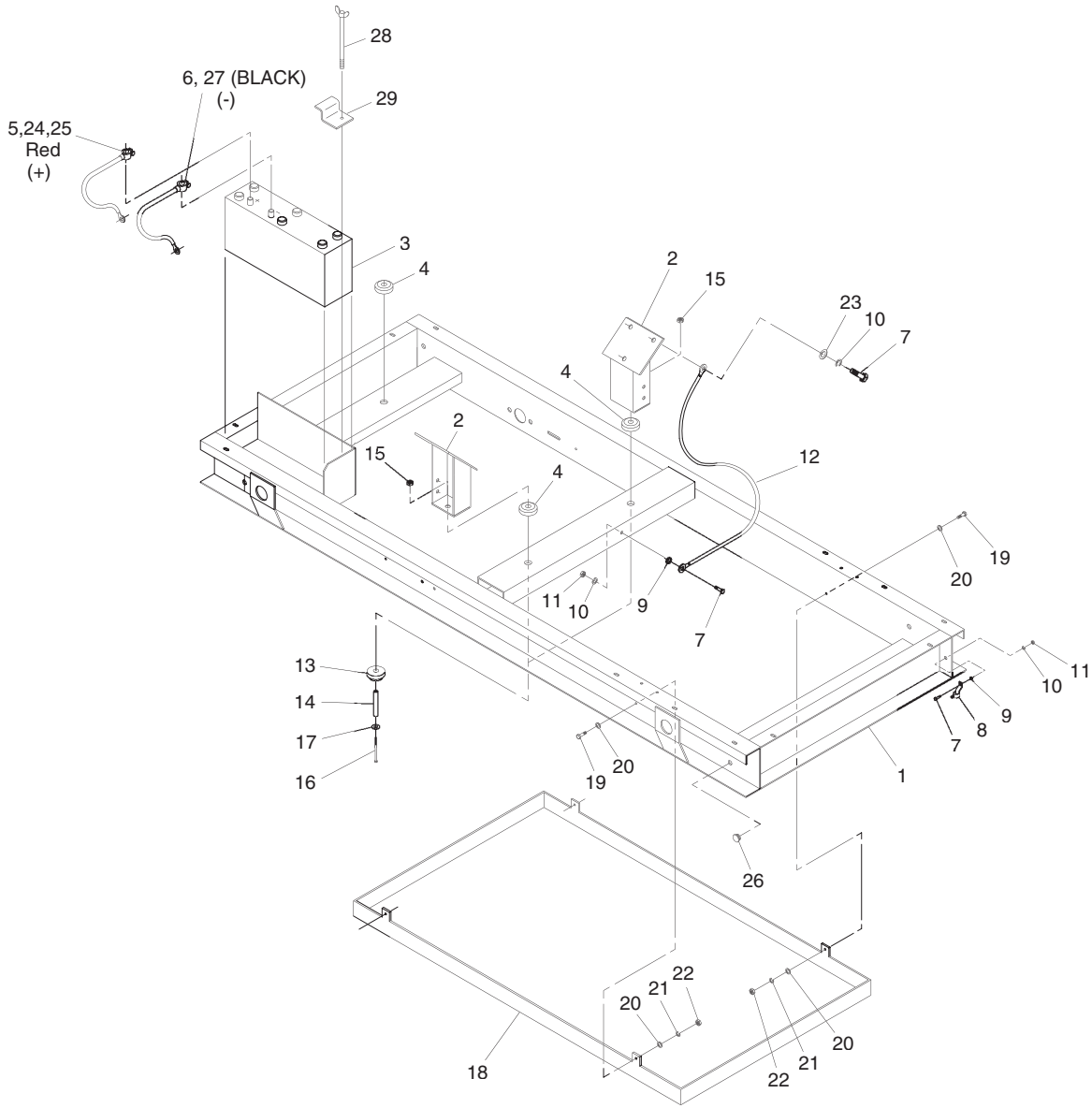

ITEM	PART NO.	QTY.	DESCRIPTION	ITEM	PART NO.	QTY.	DESCRIPTION
1	0A9658	1	BASE MOUNTING 50KW UTILITY	16	055597	4	SCREW HHC M12-1.75 X 85 G8.8
2	0C4743	2	ENGINE MOUNT 5.7L	17	052259	4	WASHER FLAT M12
3	0C3100	1	BATTERY 12VDC 460A F-3ET	18	0C3288	1	SPILL PAN SHEET MTL
4	052251A	4	VIB DAMPENER 50 WHITE	19	047411	4	SCREW HHC M6-1.0 X 16 G8.8
5	038804U	1	CABLE BATT RED #1 X 28.00	20	022473	8	WASHER FLAT 1/4 ZINC
6	038805J	1	CABLE BATT BLK #1 X 30.00	21	022097	4	WASHER LOCK M6-1/4
7	029745	8	SCREW HHC 3/8-16 X 1 G5	22	049813	4	NUT HEX M6 -1.0 G8 YEL CHR
8	061383	1	LUG SLDLSS 3/0-#4 X 13/32 CU	23	022131	6	WASHER FLAT 3/8-M10 ZINC
9	025507	2	WASHER SHAKEPROOF EXT 7/16 STL	24	050331A	1	BATT POST COV RED + (NOT SHOWN)
10	022237	8	WASHER LOCK 3/8	25	075763	1	BOOT BATT CABLE (NOT SHOWN)
11	022241	2	NUT HEX 3/8-16 STEEL	26	0C4753	8	PLUG 3/4" BUTTON
12	0536210760	1	WIRE ASSY QJ CIR BKR	27	050331	1	BATT POST COV BLK (NOT SHOWN)
13	052252	4	VIBRATION DAMPNER	28	0C7366	1	BOLT WING 1/4-20 X 8.5
14	052257	4	SPACER .49 X .62 X 1.87 PWDR/ZINC	29	0E0311	1	BRACKET, BATTERY
15	052860	4	NUT LOCKING M12-1.75				

Section 7 – Exploded Views and Parts Lists

DG 50 Generator Set
Block Heater – Drawing No. 0C8807-F

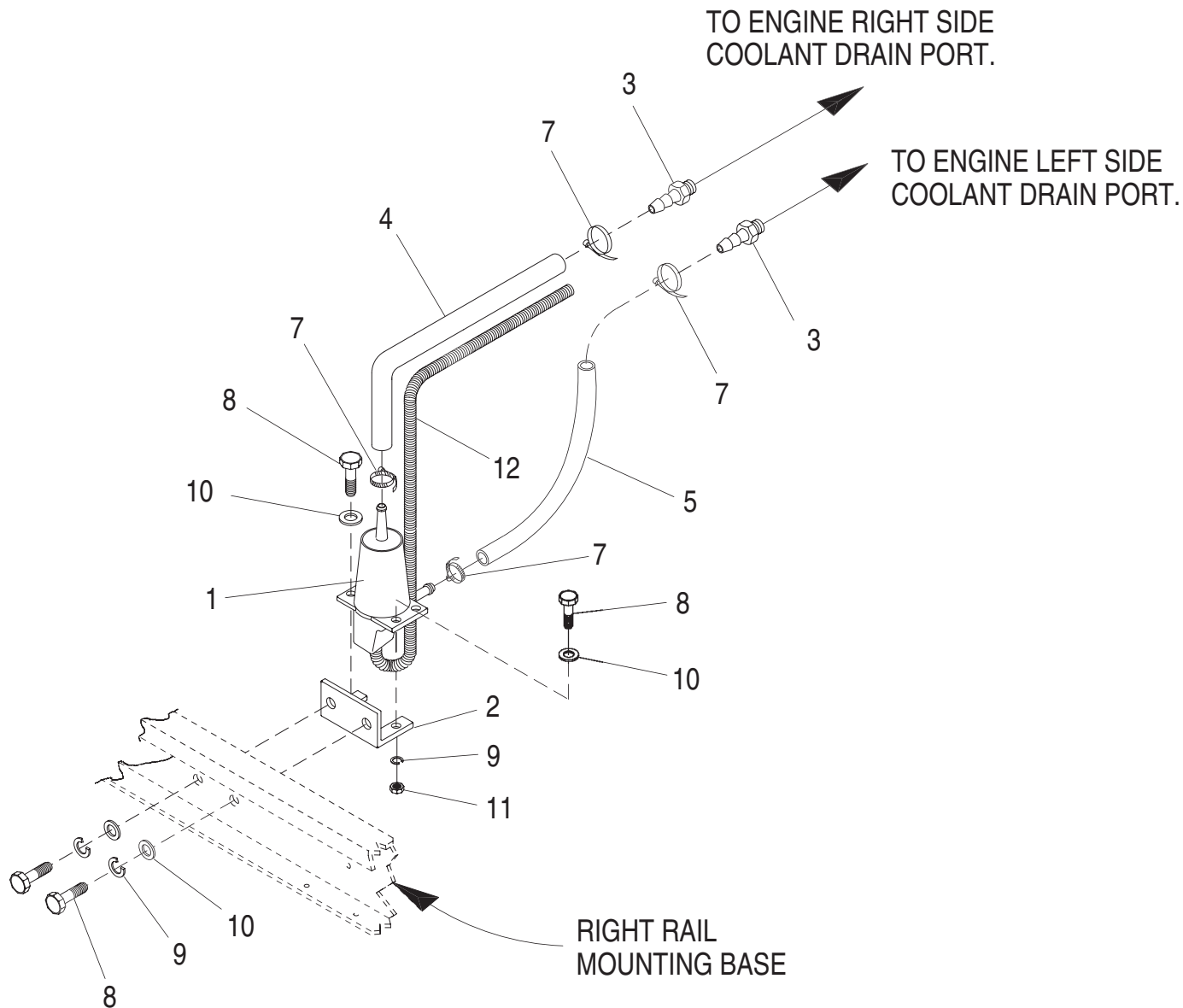
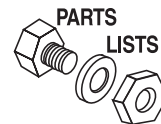

ITEM	PART NO.	QTY.	DESCRIPTION
1	0C7850	1	ASSY BLOCK HEATER
2	084427	1	BRACKET HEATER
3	053660	2	BARBED STRAIGHT 1/4 NPT X 5/8
4	0E4711	1	HOSE PREFORMED BLOCK HEATER
5	050967	1	HOSE RES 5/8 RIA 250F (20"LG)
7	057823	4	CLAMP HOSE #10 .56 - 1.06
8	047411	4	SCREW HHC M6-1.0 X 16 G8.8
9	022097	4	WASHER LOCK M6-1/4
10	022473	4	WASHER FLAT 1/4 ZINC
11	049813	2	NUT HEX M6 -1.0 G8 YEL CHR
12	077043A	1	CONDUIT FLEX .38 ID (30"LG)



Section 7 – Exploded Views and Parts Lists

DG 50 Generator Set Radiator – Drawing No. 0D9137-A

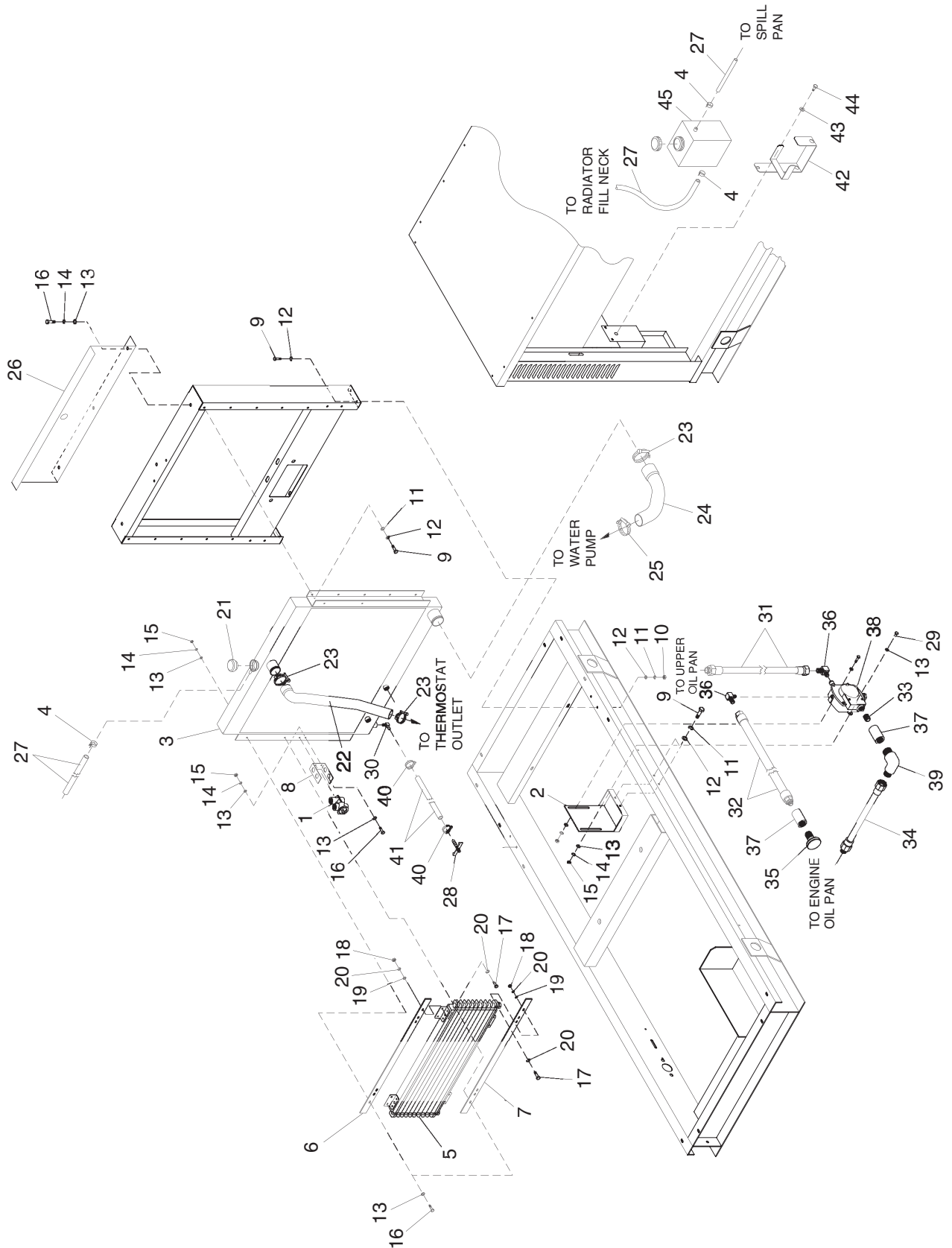

Section 7 – Exploded Views and Parts Lists

DG 50 Generator Set Radiator – Drawing No. 0D9137-A

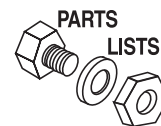

ITEM	PART NO.	QTY.	DESCRIPTION
1	0C4811	1	THERMOSTAT OIL
2	0C4410	1	BRKT MTG RENN OIL FLOAT VALVE
3	0A9847	1	RADIATOR 29" X 29" 5.7L
4	0C7649	3	CLAMP HOSE .38-.87
5	0A8825	1	COOLER OIL
6	0C4494	1	BRACKET UPPER -OIL COOLER
7	0C4495	1	BRACKET LOWER -OIL COOLER
8	0C4252	1	BRACKET THERMOSTAT
9	042907	16	SCREW HHC M8-1.25 X 16 G8.8
10	045771	4	NUT HEX M8-1.25 G8 YEL CHR
11	022129	12	WASHER LOCK M8-5/16
12	022145	16	WASHER FLAT 5/16 ZINC
13	022473	19	WASHER FLAT 1/4 ZINC
14	022097	11	WASHER LOCK M6-1/4
15	049813	8	NUT HEX M6 X 1.0 G8 YEL CHR
16	047411	9	SCREW HHC M6-1.0 X 16 G8.8
17	051718	8	SCREW HHC M4-0.7 X 10 G8.8
18	051715	8	NUT HEX M4-0.7 G8 YEL CHR
19	022264	8	WASHER LOCK M4
20	022985	16	WASHER FLAT #6 ZINC
21	046627	1	CAP RADIATOR
22	0C5373	1	HOSE UPPER RADIATOR 5.7L
23	042561	3	CLAMP HOSE #36 1.88 - 2.75
24	0C8016	1	HOSE LOWER RAD. 5.7L
25	035685	1	CLAMP HOSE #28 1.32 - 2.25
26	0C3183	1	BLOCK OFF AIR TOP
27	047290	1	HOSE RES 3/8 SINGLE BRAID (168" LG)
28	036865	1	DRAINCOCK
29	038750	2	SCREW HHC M6-1.0 X 30 G8.8
30	049340	1	BARBED EL 90 1/4 NPT X 3/8
31	0E2633G	1	OIL LINE (1275MM)
32	0E2633H	1	OIL LINE (1000MM)
33	025065	1	NIPPLE PIPE 3/8 NPT X 1-1/2
34	0E2633F	1	OIL LINE (165MM)
35	026847	1	BREATHER
36	0C4973A	2	MALE ELBOW 90DEG
37	025066	2	COUPLING FULL 3/8-18
38	0C4978	1	SWITCH OIL LEVEL
39	0C4973B	1	MALE ELBOW 90 DEG
40	086133N	2	CLAMP HI TORQUE 6.75 - 7.625
41	047290	1	HOSE RES 3/8 SINGLE BRAID (42"LG)
42	080713	1	BRACKET COOLANT TANK
43	049811	1	WASHER FLAT M6
44	092978	1	SCREW TAPTITE M6 X 20
45	060091	1	WATER BOTTLE

Section 7 – Exploded Views and Parts Lists

**DG 50 Generator Set
Alternator – Drawing No. 0C9060-F**

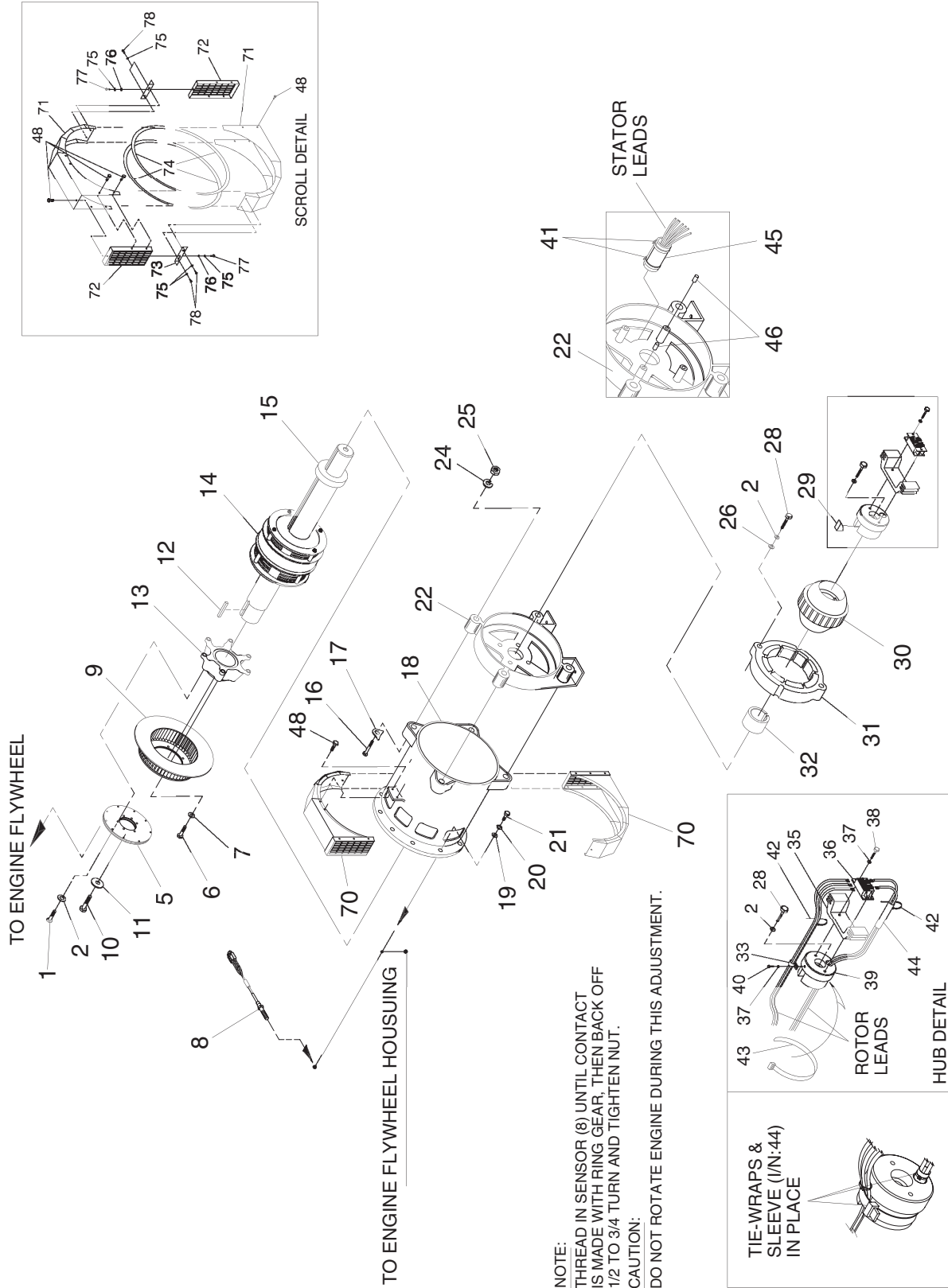

Section 7 – Exploded Views and Parts Lists

DG 50 Generator Set Alternator – Drawing No. 0C9060-F

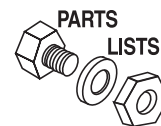

ITEM	PART NO.	QTY.	DESCRIPTION
1	055420	6	SCREW HHC M12-1.75 X 25 G10.9
2	051769	9	WASHER LOCK M12
5	0A3852	3	PLATE FLEX GM
6	055173	6	SCREW HHC M8-1.25 X 20 G10.9
7	022129	6	WASHER LOCK M8-5/16
8	0D2244M	1	ASSY MAGPICKUP (3/8-24 MALE)
9	0C4286	1	ASSY FAN W/PRESS DISC 10.75 X 3
10	0A2601	1	SCREW HHC M16-2.0 X 45 G8.8
11	0A2602	1	WASHER FLAT .688 ID X 3.25 OD
12	0A1138	1	KEY SQ 3/8 X 2-1/2 STEEL
13	021941	1	COUPLER 390 SAE
14	0C4746	1	ASSY ROTOR 50KW 4 POLE
15	052624	1	BEARING BALL 6212 SEALED
16	0A5580	4	SCREW HHC M14-2.0 X 140 G8.8
17	0A1633	4	WASHER 390 SAE ALT.
18	0C4747	1	ASSY STATOR 50KW 277/480V
	0D3228	1	ASSY STATOR 50KW 120/208V
19	022131	12	WASHER FLAT 3/8-M10 ZINC
20	046526	12	WASHER LOCK M10
21	057642	12	SCREW HHC M10-1.5 X 40 G10.9
22	068113	1	CARRIER REAR BRG 15"
24	043123	4	WASHER LOCK M14
25	051779	4	NUT HEX M14-2 G8 YEL CHR
26	052259	2	WASHER FLAT M12
28	068406	3	SCREW HHC M12-1.75 X 60 G10.9
29	072878	1	KEY SQ 3/8 X 3-1/4 STEEL
30	087272	1	ASSY EXCITER 2.00" STK
31	068405	1	EXCITER FIELD 15" 2" LG
32	092950	1	COLLAR SLIP FIT 390 MM
33	020151	1	CLAMP VINYL .312 X .203 Z
35	090063	1	BRIDGE SUPPORT DIODE 15"
36	090152	1	ASSY BRIDGE RECTIFIER
37	023365	3	WASHER SHAKEPROOF INT #8
38	033143	2	SCREW HHM #8-32 X 7/8
39	090064	1	CAP END ROTOR 390MM
40	033133	1	SCREW HHM #8-32 X 3/8
41	031980	2	TIE WRAP 14.6" X .14" NATL UL
42	028739A	2	TIE WRAP 3.9" X .10" BLK UL
43	085662D	1	WRAP TIE 17.7" X .35" BLK UL
44	022661L	1	SLEEVE UL #0 .330 ID
45	083549	1	SLEEVE-RUBBER
46	022392	2	PIN DOWEL 1/2 X 1-1/4
48	0A2110	12	SCREW SWAGE 1/4-20 X 1/2 Z/YC
53	0C8026	1	COATING PROTECTIVE (NOT SHOWN)
70	0A4089	1	ASSY SCROLL 390 SAE
71	0A2491	2	SHROUD ALT SHEET METAL
72	0A2497	2	SCREEN SHROUD SAE
73	0A2496	2	BRKT TENSIONER SAE SCROLL
74	056326	8.4'	TRIM VINYL BLACK 1/8GP
75	022097	6	WASHER LOCK M6-1/4
76	049811	2	WASHER FLAT M6
77	045757	2	SCREW HHC M6-1.0 X 25 G8.8
78	043116	4	SCREW HHC M6-1.0 X 12 G8.8

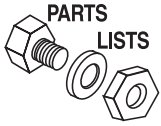

Section 7 – Exploded Views and Parts Lists

**DG 50 Generator Set
Compartment – Drawing No. 0D3578-B**

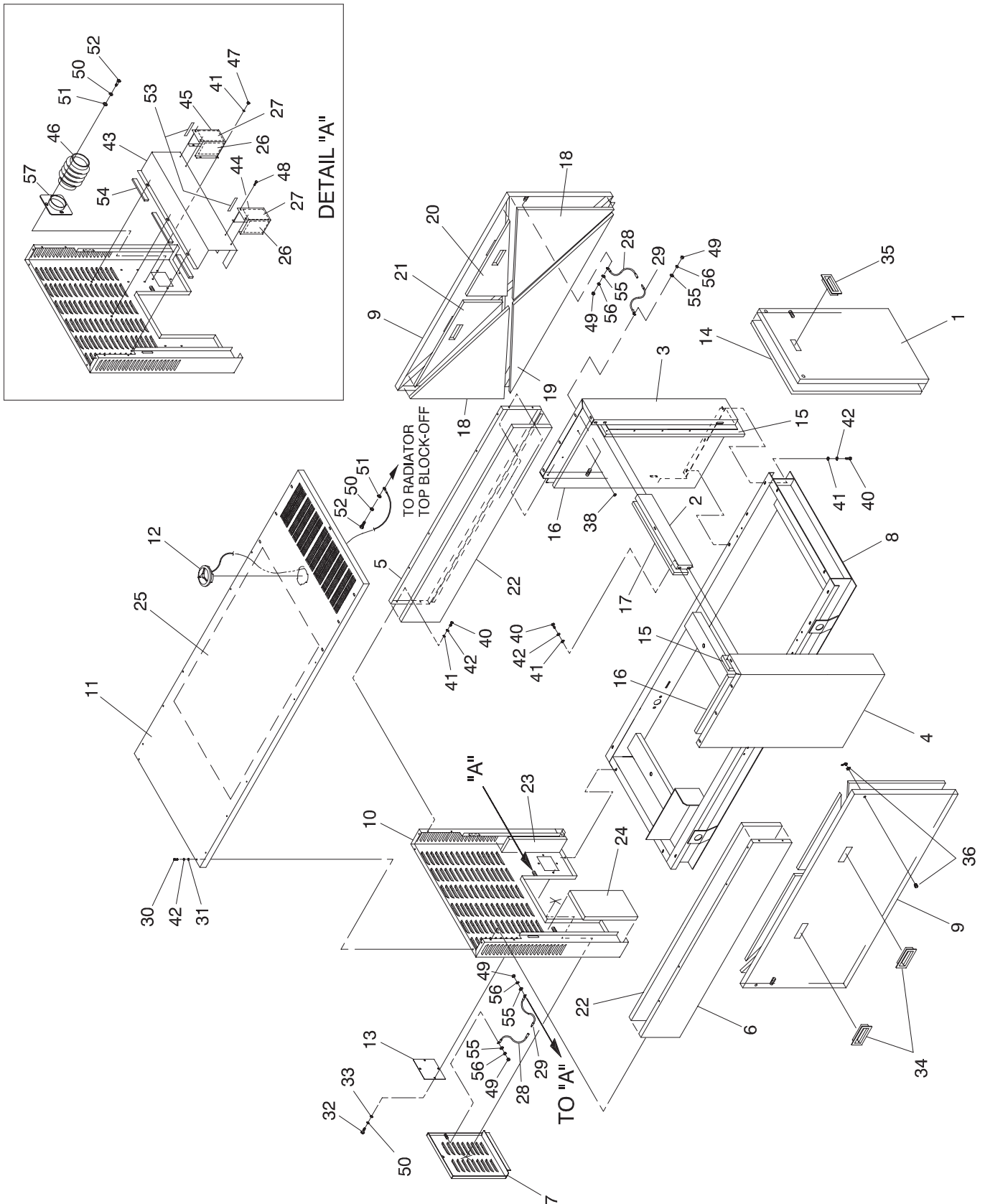

Section 7 — Exploded Views and Parts Lists

DG 50 Generator Set Compartment – Drawing No. 0D3578-B

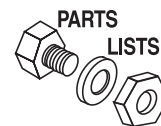

ITEM	PART NO.	QTY.	DESCRIPTION
1	0C2916	1	DOOR FRONT 5.7L
2	0C2911	1	SUPPORT FRONT 5.7L
3	0C1499	1	POST CORNER LH FRONT
4	0C1499A	1	POST CORNER RH FRONT
5	0C1202	1	SUPPORT LH TOP
6	0C1202A	1	SUPPORT RH TOP
7	0C9444	1	DOOR REAR ACCESS
8	0A9658	REF.	BASE MOUNTING 50 KW UTILITY
9	0C1447	2	WELDMNT 5.7 UTILITY DOOR
10	0C4277	1	WELDMNT PANEL REAR
11	0C1953	1	ROOF 5.7L
12	0C2634A	1	ASSY COVER ACCESS
13	0C5029	1	PLATE UTILITY-IN GLAND
14 *	0C4334	1	CERWOOL FRONT DOOR
15 *	0C4334A	2	CERWOOL C-POST FRONT
16 *	0C4334B	2	CERWOOL C POST SIDE
17 *	0C4334C	1	CERWOOL FRONT DOOR
18 *	0C4334D	4	CERWOOL SIDE DOOR UPPER
19 *	0C4334E	2	CERWOOL SIDE DOOR LOWER
20 **	0C3201K	2	INSULATION SIDE DOOR
21 **	0C3201J	2	INSULATION SIDE DOOR
22 **	0C3201B	2	INSULATION SUPPORT TOP
23 **	0C3201H	2	INSULATION REAR PANEL SIDE
24 **	0C3201G	1	INSULATION REAR PANEL BOTTOM
25 **	0C3201A	1	INSULATION ROOF
26 **	0C3201C	4	INSULATION ALT AIR INLET SIDE
27 **	0C3201D	2	INSULATION ALT AIR INLET BACK
28	0536210208	4	ASSY WIRE 14 AWG 6" PLUG
29	0536210145	4	ASSY WIRE 14 AWG 6" RECPT
30	0C3181	17	SCREW BHSC M8-1.25 X 20 SS
31	027756	17	WASHER NYLON .312
32	0A3359	4	SCREW BHSC M6-1.0 X 16 SS
33	0A2115	4	WASHER NYLON .250
34	0C3180	4	HANDLE DOOR
35	020823	1	HANDLE PVC BLACK
36	020825	7	LATCH VICE ACTION
37	020826	2	KEY VICE ACTION LATCH (NOT SHOWN)
38	078115	100	WASHER SELF LOCKING DOME
39	0C8150	33.5'	SEAL RUBBER DOOR (NOT SHOWN)
40	042907	24	SCREW HHC M8-1.25 X 16 G8.8
41	022129	35	WASHER LOCK M8-5/16
42	022145	24	WASHER FLAT 5/16 ZINC
43	0C3707	1	DUCT ALTERNATOR TOP
44	0C3708	1	DUCT RH SIDE ALT AIR INLET
45	0C4961	1	DUCT LH SIDE ALT AIR INLET
46	0C8043	1	BELLOWS UTILITY-IN
47	022259	11	NUT HEX 5/16-18 STEEL
48	086292	4	SCREW DRILLTITE #10-16 X 3/4
49	028430	8	NUT HEX #10-24 STEEL
50	022097	5	WASHER LOCK M6-1/4
51	022473	5	WASHER FLAT 1/4 ZINC
52	047411	5	SCREW HHC M6-1.0 X 16 G8.8
53	056326	1 FT.	TRIM VINYL BLACK 1/8 GP
54	029451	7.5 FT.	TAPE ELEC UL FOAM 1/8 X 1/2
55	023897	8	WASHER FLAT #10 ZINC
56	023762	8	WASHER SHAKEPROOF EXT #10 STL
57	0C8591	2	WLDMNT UTIL-IN FLANG

* HEAT INSULATION KIT P/N 0C3788

** INSULATION KIT P/N 0C3201

Section 7 – Exploded Views and Parts Lists

**DG 50 Generator Set
Fan Drive – Drawing No. 0C4849-K**

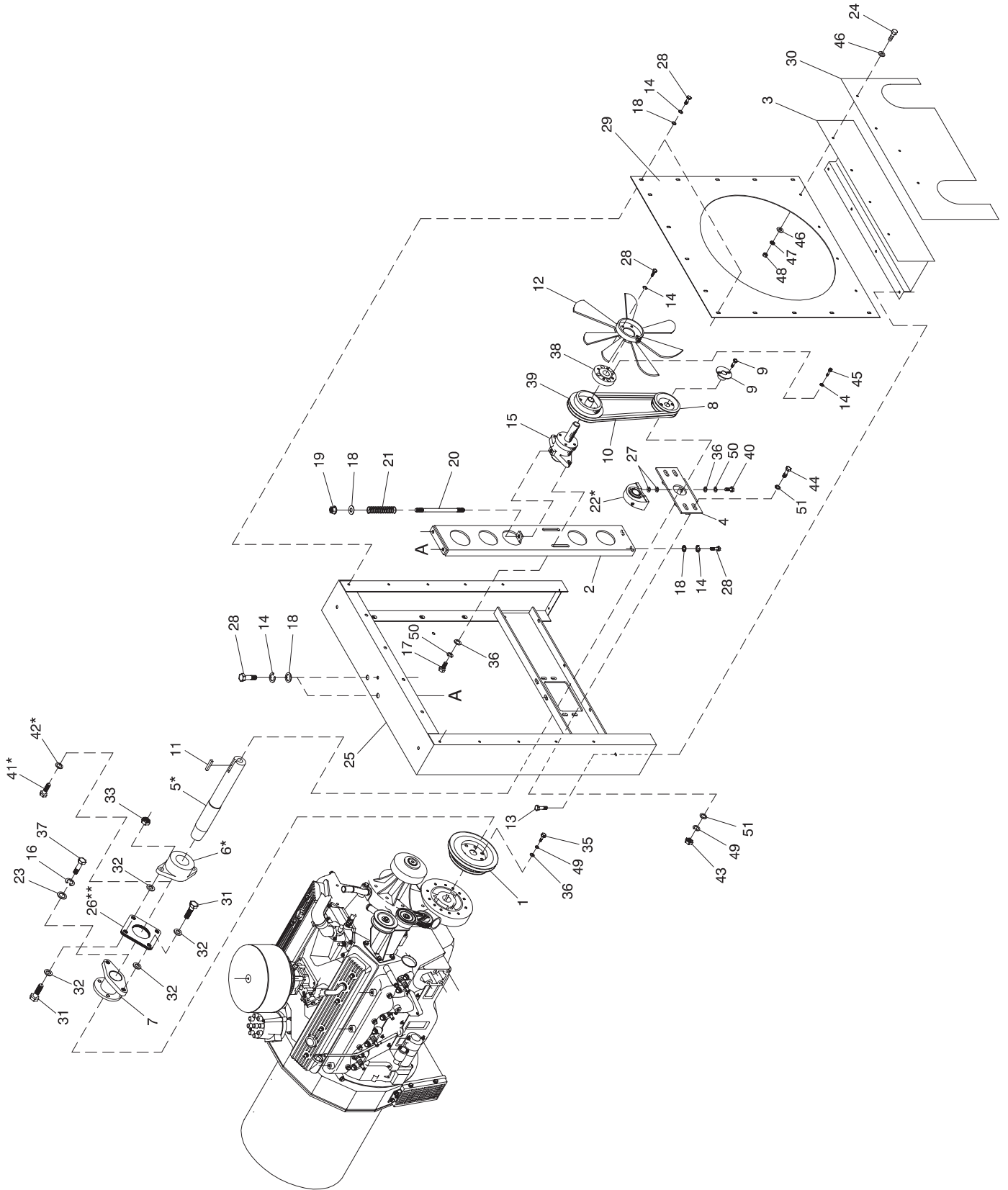

Section 7 – Exploded Views and Parts Lists

**DG 50 Generator Set
Fan Drive – Drawing No. 0C4849-K**

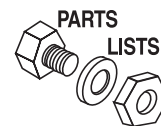

ITEM	PART NO.	QTY.	DESCRIPTION
1	0A4239	1	PULLEY CRANKSHAFT
2	0C1726	1	BRACKET BELT TENSIONER
3	0C4349	1	SUPPORT VENTURI BOTTOM
4	0D5136	1	BRACKET BEARING SUPPORT
5 *	0C6475	1	SHAFT FLEX DRIVE 5.7
6 *	0C8309	1	HUB FLEX COUPLING
7	0C8310	1	HUB FLEX COUPLING
8	0C2737	1	SHEAVE TWO-GROOVE 5.7L
9	0C4326	1	SHEAVE HUB H 1.125
10	0C6549B	2	V-BELT GREEN 50"
11	023138	1	KEY SQ 1/4 X 1 STEEL
12	098184	1	FAN-COOLING 26"
13	074908	4	SCREW TAPTITE M5-0.8X10 BP
14	022129	26	WASHER LOCK M8-5/16
15	0C4649	1	ASSY FAN SUPPORT
16	022250	1	WASHER FLAT 7/16
17	057642	2	SCREW HHC M10-1.5 X 40 G10.9
18	022145	19	WASHER FLAT 5/16 ZINC
19	052858	1	NUT LOCK FLANGE M8-1.25
20	04576100BY	1	STUD M8-1.25 X 200 G5 ZINC
21	042962	1	SPRING COMPRESSION
22 *	0C8364	1	ASSY PILLOW BLOCK
23	022302	1	WASHER LOCK 7/16
24	049815	4	SCREW HHC M5-0.8 X 16 G8.8
25	0D5135	1	SUPPORT RADIATOR WELDMENT
26 **	0C7043	12	DISK FLEX
27	0C8126	4	WASHER BELLVILLE .442 I.D.
28	042907	22	SCREW HHC M8-1.25 X 16 G8.8
29	0A9853	1	VENTURI 50KW 5.7L
30	0C3202	1	BLOCKOFF BOTTOM 5.7
31	0C8146	4	BOLT 5/16-24X1.25
32	0C8145	8	WASHER FLEX (THIN)
33	0C8165	2	NUT LOCK HEX 5/16-24 NYL INS
35	0C5713	3	SCREW SHC 3/8-24X1-1/2
36	022131	7	WASHER FLAT 3/8-M10 ZINC
37	0A7814	1	SCREW HHC 7/16-20 X 3-1/4 G5
38	0A7885	1	ADAPTOR FAN 7.4
39	058793	1	PULLEY AUTO 7.00 PD
40	049814	2	SCREW HHC M10-1.5 X 25 G8.8
41 *	049814	1	SCREW HHC M10-1.5 X 25 G8.8
42 *	052644	1	SPACER .5 X 1.5 X .25 ST/ZNC
43	022241	4	NUT HEX 3/8-16 STEEL
44	029745	4	SCREW HHC 3/8-16 X 1 G5
45	049821	4	SCREW SHC M8-1.25 X 30 G12.9
46	023897	8	WASHER FLAT #10 ZINC
47	022152	4	WASHER LOCK #10
48	051716	4	NUT HEX M5-0.8 G8 YEL CHR
49	022237	7	WASHER LOCK 3/8
50	046526	4	WASHER LOCK M10
51	0A5768	8	WASHER FLAT HEAVY DUTY

* KIT, DRIVE SHAFT P/N 0E3395A

** KIT, FLEX DISK P/N 0E3394 (SERVICE KIT)

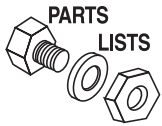

Section 7 – Exploded Views and Parts Lists

DG 50 Generator Set Engine Parts – Drawing No. 0D3695-H

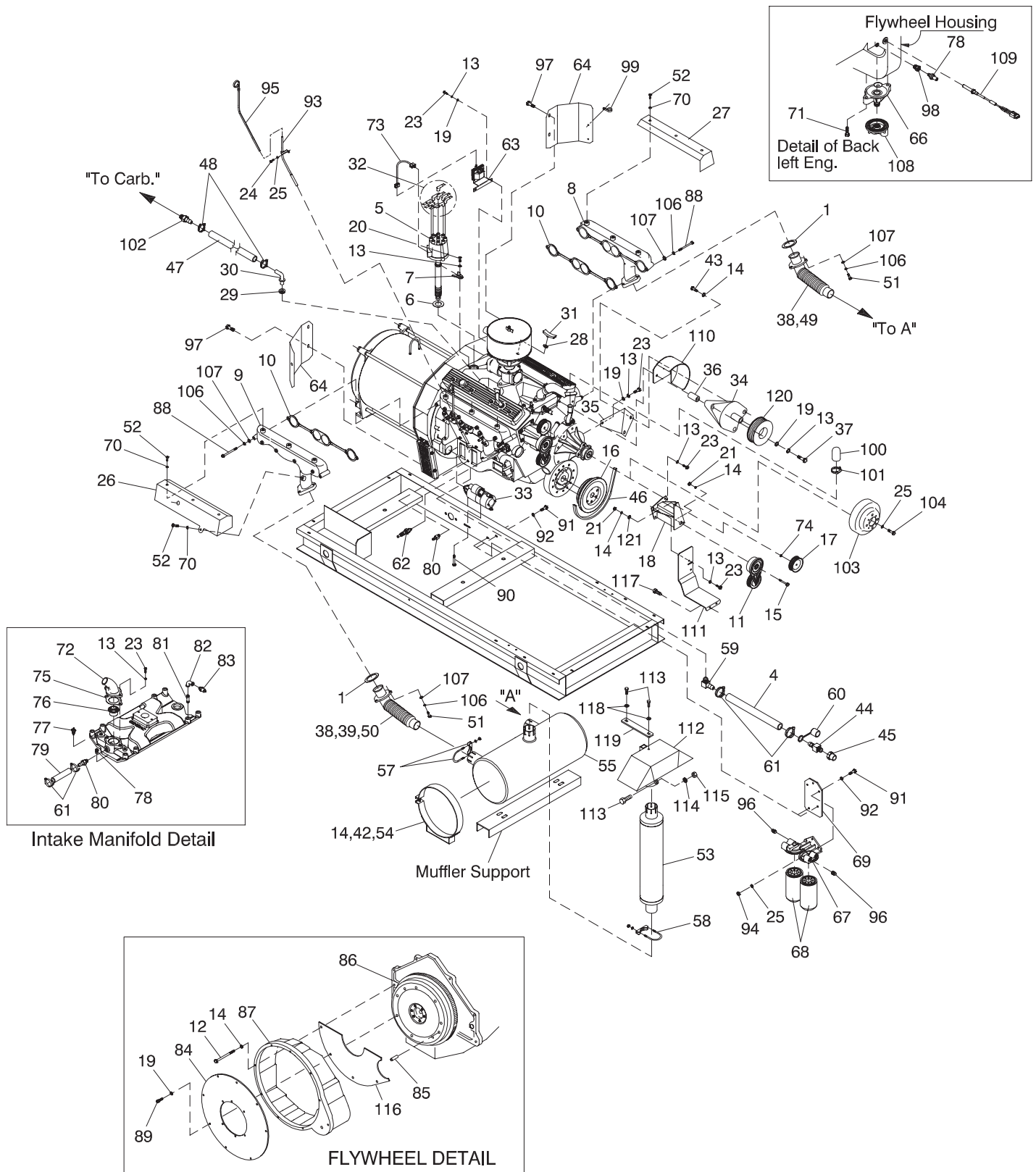

Section 7 – Exploded Views and Parts Lists

DG 50 Generator Set Engine Parts – Drawing No. 0D3695-H

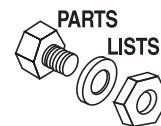

ITEM	PART NO.	QTY.	DESCRIPTION	ITEM	PART NO.	QTY.	DESCRIPTION
1	044149	2	GASKET EXHAUST RING	67**	0C4812	1	FILTER OIL REMOTE
2	0C7021	1	HARNES ENGINE DG50 (NOT SHOWN)	68 **	0C3784	2	FILTER OIL 5.7L
4	050967	1	HOSE RES 5/8 RIA 250F (24" LG)	69 **	0C4229	1	BRACKET OIL FILTER
5 ***	0C4386	1	DISTRIBUTOR EST	70	070006	8	WASHER LOCK M8 SSTL
6 ***	0C4389	1	GASKET DISTRIBUTOR	71	058007	2	BOLT OIL FILTER
7 ***	0C4254	1	HOLD-DOWN DISTRIBUTOR	72	069939	1	HOUSING THERMOSTAT
8	0C3061	1	MANIFOLD EXH 5.7 LH	73	0A4244	1	CONNECT COIL TO DIST
9	0C3061A	1	MANIFOLD EXH 5.7 RH	74	052259	1	WASHER FLAT M12
10	055489	2	GASKET EXH. MANIFOLD	75	048665	1	GASKET THERMOSTAT
11	0C2885A	1	TENSIONER HI TEMP GREASE	76	075885	1	THERMOSTAT 195 DEG F
12	0D6585	6	SCREW SHC 3/8-16 X 3.0 BLK OX	77	057522	1	SENSOR COOLANT LEVEL
13	022237	8	WASHER LOCK 3/8	78	053667	2	SENDER WATER TEMP
14	046526	14	WASHER LOCK M10	79	0A6283	1	HOSE PREFORMED BLOCK HEATER
15	0C3756	1	BOLT TENSIONER PULLEY	80	044117	2	BARBED STR 3/8 NPT X 5/8
16	REF.	1	PULLEY CRANK SHAFT	81	039558	1	NIPPLE PIPE 1/8 NPT X 1-3/4
17	0A4241A	1	PULLEY HI TEMP GREASE	82	028405	1	ELBOW 90D 1/8 NPT
18	0C6239	1	BRACKET MOUNTING WELD ASSY	83	053666	1	SENDER OIL PRESSURE
19	022131	16	WASHER FLAT M10-3/8 ZINC	84	0A3852	3	PLATE FLEX GM
20	025017	1	SCREW HHC 3/8-16 X 1/2 G5	85	048191	2	PIN MET DOWEL M10 X 24
21	045772	2	NUT HEX M10-1.5 G8 YEL CHR	86	0C3154	1	FLYWHEEL REWORK
23	029745	6	SCREW HHC 3/8-16 X 1 G5	87	098239	1	CASTING ADAPTOR
24	022142	1	SCREW HHC 5/16-18 X 3/4 G5	88	0D2610	12	SCREW HHC 3/8-16 X 3-3/4 SSTL
25	022129	8	WASHER LOCK M8-5/16	89	043097	8	SCREW SHC 3/8-16 X 1 G8.8 NZ
26	0C4967A	1	SHIELD HEAT RH	90	058385A	2	STRT BLT GM 4-1/4"
27	0C4967	1	SHIELD HEAT LH	91	043107	5	SCREW HHC M8-1.25 X 25 G8.8
28	0C5320	1	GROMMET BREATHER 5.7	92	022145	5	WASHER FLAT 5/16 ZINC
29	0C5318	1	GROMMET PCV 5.7L	93	058365	1	TUBE DIPSTICK OIL
30	0A4121	1	VALVE PCV	94	045771	3	NUT HEX M8-1.25 G8 YEL CHR
31	069870	1	BREATHER CRANK CASE	95	058366	1	DIPSTICK OIL
32	0C4701	1	WIRE SET SPARK PLUG	96	024310	2	PLUG STD PIPE 1/2 STEEL SQ HD
33	059056A	1	MOTOR STARTER	97	0A2110	4	SCREW SWAGE 1/4-20 X 1/2 Z/YC
34	0C6234	1	ALTERNATOR DC ASSEMBLY	98	035579	1	BUSHING REDUCER 1/4 TO 1/8
35	0D6200	1	BRACKET ALTERNATOR SUPPORT	99	055934N	1	CLAMP VINYL 1.31 X .281 Z
36	0A5737C	1	SPACER DC ALTERNATOR	100	077996	1	CAP HOSE
37	033819	1	SCREW HHC 3/8-16 X 4 G5	101	057822	1	CLAMP HOSE #8 .53 - 1.00
38	0D3508	2	INSULATION EXH PIPE (NOT SHOWN)	102	035461	1	BARBED STR 1/4 NPT X 3/8
39	0C9748	1	PLUG M18 - 1.50	103	0A4240	1	PULLEY WATER PUMP
42	094194	2	BAND-10" CLEANER MTG	104	042907	4	SCREW HHC M8-1.25 X 16 G8.8
43	049814	2	SCREW HHC M10-1.5 X 25 G8.8	106	085917	18	WASHER LOCK 3/8 SS
44	044118	1	BARBED STR 1/2NPT X 5/8	107	088775	18	WASHER FLAT 3/8 SS
45	0C4993	1	DISCONNECT QUICK 1/2 NPT FEMALE	108	0C5899	1	ADAPTOR UNIVERSAL SPIN ON
46	0C9617	1	BELT SERPENTINE	109	0D2244M	1	ASSY, MAGPICKUP(3/8-24 MALE)
47	047290	1	HOSE 3/8 ID SINGLE BRAID (12" LG)	110	0C9327	1	SHIELD HEAT EXHAUST LH
48	0C7649	2	CLAMP HOSE .38 - .87	111	0C9326	1	SHIELD HEAT EXHAUST RH
49	0D1596	1	PIPE EXHAUST MANIFOLD LH	112	0C3199	1	HAT MUFFLER 5.7L
50	0D1597	1	PIPE EXHAUST MANIFOLD RH	113	051767	3	SCREW HHC M6-1.0 X 45 G8.8
51	0D2611	6	SCREW HHC 3/8-16 X 1-3/4 SSTL	114	022097	1	WASHER LOCK M6-1/4
52	0D2608	8	SCREW HHC 5/16-18 X 1/2 SSTL	115	049813	1	NUT HEX M6-1.0 G8 YEL CHR
53 *	0D3389	1	MUFFLER CATALYTIC 3" PIPE	116	055474	1	FLYWHEEL COVER
54	051755	4	SCREW HHC M10-1.5 X 16 G8.8	117	090388	2	SCREW HHTT M6-1.0 X 12 YC
55	0C1551	1	MUFFLER HORIZONTAL 5.7L	118	049811	2	WASHER FLAT M6
57	0C7947	2	BOLT U 3/8-16 X 2.50	119	0D6518	1	BRACE MUFFLER
58	055978	1	BOLT U 3/8-16 X 3.25	120	0A7801C	REF.	PULLEY POLY-V 97 OD.
59	056460	1	BARBED EL 90 1/2 NPT X 5/8	121	0A1646	1	WASHER FLAT M16
60	0D2787	1	PLUG DUST FEMALE QUICK COUPLNG				
61	035472	4	CLAMP HOSE #6 .43 - .78				
62	0D2514	8	SPARK PLUG 5.7L GM				
63	0C4385	1	COIL IGNITION				
64	0C4288	2	DEFLECT ALT AIR EXIT				
65 **	0E2669A	1	KIT OIL LINE (NOT SHOWN)				
66	058008	1	ADAPTOR OIL FILTER				

* NOTE: ITEM 53 IS FOR ULTRA-LOW EMISSIONS APPLICATIONS AND FOR COMPLIANCE WITH SOUTH COAST AIR QUALITY MANAGEMENT DISTRICT REGULATIONS FOR NON-EMERGENCY NATURAL GAS ENGINES.

** REF. KIT P/N 0C8867

*** REF. ENGINE P/N 0C3289

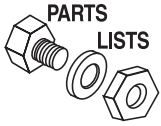

Section 7 – Exploded Views and Parts Lists

DG 50 Generator Set

Control Panel & Connection Box – Drawing No. 0C6462-G

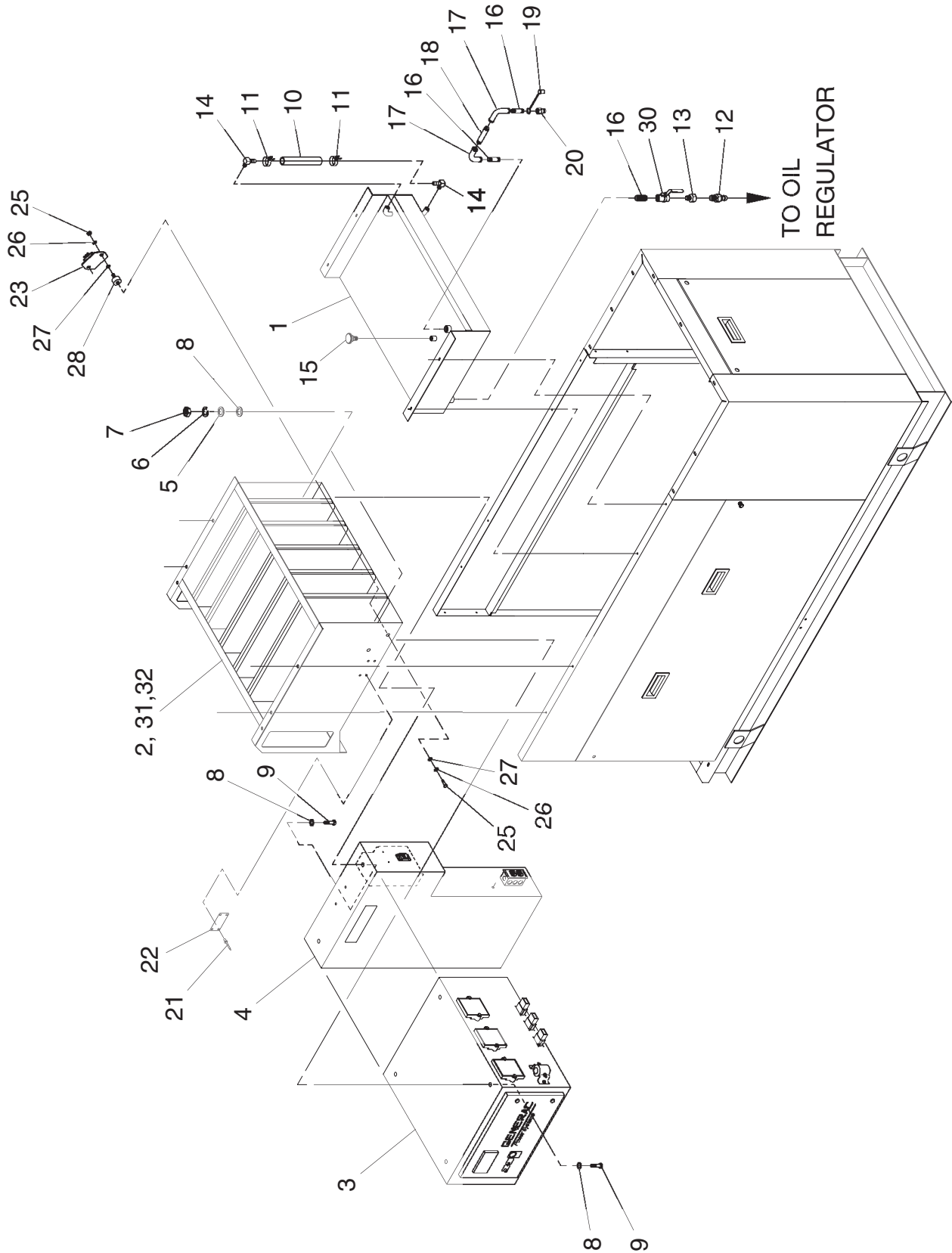

Section 7 – Exploded Views and Parts Lists

DG 50 Generator Set Control Panel & Connection Box – Drawing No. 0C6462-G

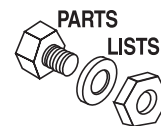

ITEM	PART NO.	QTY.	DESCRIPTION
1	0C3751	1	WELDMENT OIL PAN
2	0C3630	1	WELDMENT AIR INLET DUCT
3	0C5946	1	ASSY BOX F-PANEL 277/480
	0C9578	1	ASSY C-PANEL 120/208
4	0C5334	1	ASSY CONN PANEL CTTS 5.7L
	0C7359	1	ASSY CONN BOX 208/120
5	022131	6	WASHER FLAT 3/8-M10 ZINC
6	022237	6	WASHER LOCK 3/8
7	022241	6	NUT HEX 3/8-16 STEEL
8	090977	12	WASHER FLAT .375ID X .875OD
9	031578	6	SCREW HHC 3/8-16 X 1-1/2 G8
10	0C7831	5'	HOSE 5/16 ID OIL TUBE
11	048031G	2	CLAMP HOSE BAND
12	055596	1	STRAIGHT BRBD 3/8 NPT X 3/8
13	030418	1	BUSHING REDUCER 1/2 TO 3/8
14	059502	2	BARBEL EL 90 1/4 NPT X 5/16
15	026847	1	BREATHER
16	030985	3	NIPPLE CLOSE 1/2 X 1.125
17	030419	2	ELBOW 90D 1/2 NPT
18	025429	1	NIPPLE PIPE 1/2 NPT X 4
19	0C3158	1	COVER DUST
20	0C3159	1	DISCONNECT QUICK 1/2 NPT MALE
21	036261	4	RIVET POP .125 X .129-.133/#30
22	045452S	1	PLATE DATA NAME
23	0A2702	1	REGULATOR VOLTAGE (20A.)
24	0C7599	1	HARNESS D.C. ALT (NOT SHOWN)
25	022127	4	NUT HEX 1/4-20 STEEL
26	022097	4	WASHER LOCK M6-1/4
27	022473	4	WASHER FLAT 1/4 ZINC
28	027831	2	VIB MOUNT .50 X 1.0 X 1/4-20
30	078944	1	VALVE BALL
31	0C3201E	2	INSULATION AIR INLET DUCT SIDE
32	0C3201F	5	INSULATION AIR INLET DUCT MIDDLE

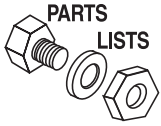

Section 7 – Exploded Views and Parts Lists

DG 50 Generator Set Carburetor – Drawing No. 0D3566-C

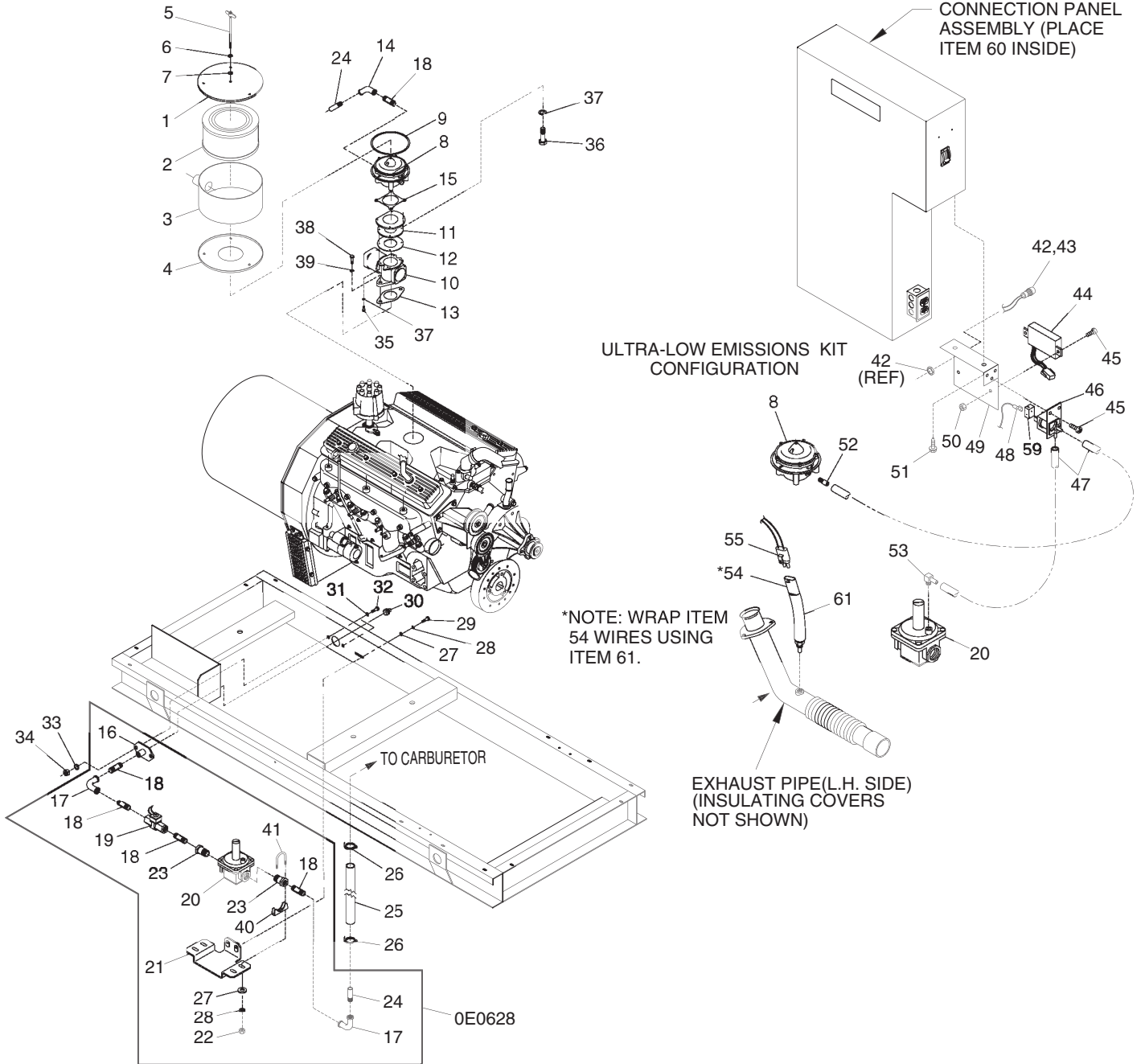

Section 7 – Exploded Views and Parts Lists

DG 50 Generator Set Carburetor – Drawing No. 0D3566-C

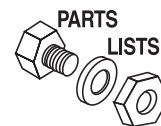

ITEM	PART NO.	QTY.	DESCRIPTION	ITEM	PART NO.	QTY.	DESCRIPTION
1	0C4236	1	PLATE AIR CLEANER TOP	32	051778	2	SCREW HHC M14-2.0 X 25 G8.8
2	0C3197	1	AIR CLEANER 50KW5.7	33	043123	2	WASHER LOCK M14
3	0C4240	1	WELDMENT AIR CLEANER HOUSING	34	051779	2	NUT HEX M14-2 G8 YEL CHR
4	0C4236A	1	PLATE AIR CLEANER BOTTOM	35	0C7908	4	SCREW SHC #10-32 X 5/8 G8.8 NZ
5	0C7366	1	BOLT WING 1/4-20 X 8.5	36	064090	4	SCREW PHM SEMS #12-24 X 5/8 EX
6	022097	1	WASHER LOCK M6-1/4	37	022152	8	WASHER LOCK #10
7	022473	1	WASHER FLAT 1/4 ZINC	38	029745	2	SCREW HHC 3/8-16 X 1 G5
8	0C7650A	1	MIXER (ONLY) NATURAL GAS	39	022237	2	WASHER LOCK 3/8
9	061258	1	GASKET AIR CLEANER	40	028237	2	SADDLE 1-3/8
10	0D3485	1	ASSY THROTTLE PF42 WIRE CONN	41	028238	2	BOLT U 5/16-18 X 1.53
11	0C7820	1	CASTING CARB ADAPTOR	42	0D3442N	1	LIGHT WARNING
12	0C7060	1	GASKET CARBURETOR ADAPTOR	43	0D3442P	1	DECAL
13	0C7059	1	GASKET GOVERNOR THROTTLE BODY	44	0D3442A	1	CONTROLLER AIR/FUEL RATIO
14	026488	1	ELBOW 45D 3/4 NPT	45	036906	4	SCREW PPHM #6-32 X 1
15	0A6613	1	GASKET CARB	46	0D3442H	1	VALVE SOLENOID
16	065907	1	SUPPORT SOLENOID NAT GAS	47	0D3442K	1	VACUUM LINE 3/16
17	026812	2	ELBOW 90D 3/4 NPT	48	0D3442D	2	CONNECTOR SPADE
18	026915	5	NIPPLE CLOSE 3/4 X 1.375	49	0D3796	1	BRACKET AIR/FUEL CONTROLLER
19	0C7598	1	ASSY NATURAL GAS SOLENOID	50	082625	4	NUT LOCK HEX #6-32 NYL INSERT
20	0D2758	1	REGULATOR N/G (R600S)	51	090388	2	SCREW TAPTITE M6-1.0 X 12 BP
21	0E0521	1	SUPPORT REGULATOR	52	0D3442M	1	VACUUM FITTING (BRASS)
22	022259	4	NUT HEX 5/16-18 STEEL	53	0D3442L	1	VACUUM ELBOW (PLASTIC)
23	026577	2	BUSHING REDUCER 1 TO 3/4	54	0D3442G	1	SENSOR OXYGEN
24	028641	2	NIPPLE TOE 3/4 NPT X 2	55	0D3442F	1	CONNECTOR OXYGEN SENSOR
25	057422	1	HOSE 1IN ID LP GAS (38" LONG)	56	0D3442B	1	HARNES WIRING 6 PIN CONNECTOR (NOT SHOWN)
26	057824	2	CLAMP HOSE #16 .87 - 1.50	57	0D3442C	1	WIRE LOOM (NOT SHOWN)
27	022145	6	WASHER FLAT 5/16 ZINC	58	0D3442E	1	CONNECTOR RING (NOT SHOWN)
28	022129	6	WASHER LOCK M8-5/16	59	0D3442J	1	FILTER FOAM
29	022142	2	SCREW HHC 5/16-18 X 3/4 G5	60	0D3442Q	1	MANUAL TECHNICAL (NOT SHOWN)
30	025655	1	PLUG STD PIPE 3/4 STEEL SQ HD	61	067053	1	SLEEVING UL 7/8 ID (11" LONG)
31	022132	2	WASHER FLAT 9/16 ZINC				



Section 8 – Warranty

DG 50 Generator Set

GENERAC POWER SYSTEMS STANDARD TWO-YEAR LIMITED WARRANTY FOR "DG-50"

NOTE: ALL UNITS MUST HAVE A STARTUP INSPECTION PERFORM BY AN AUTHORIZED GENERAC DEALER.

For a period of 2 (two) years or 3,000 (three thousand) hours of operation from the date of sale, which ever occurs first, Generac Power Systems, Inc. will, at its option, repair or replace any part which, upon examination, inspection, and testing by Generac Power Systems or a Generac Power Systems Authorized Warranty Service Facility, is found to be defective under normal use and service, in accordance with the warranty schedule set forth below. Any equipment that the purchaser/owner claims to be defective must be returned to, and examined by the nearest Generac Power Systems Authorized Warranty Service Facility. All transportation costs under the warranty, including return to the factory, are to be borne and prepaid by the purchaser/owner. This warranty applies only to Generac Power Systems Generators sold as and rated as "DG-50" units as Generac Power Systems, Inc. have defined "DG-50", provided said generator has been initially installed and inspected on-site by a Generac Power Systems Authorized Service Dealer or branch thereof. A scheduled maintenance agreement with a local Authorized Generac Power Systems Dealer is highly recommended to verify adequate service has been performed on the unit throughout the warranty period.

WARRANTY SCHEDULE

YEAR ONE — 100% (one hundred percent) coverage on mileage*, labor, and parts listed.

• **ALL COMPONENTS**

YEAR TWO — 100% (one hundred percent) coverage on parts listed.

• **ALL COMPONENTS — *PARTS ONLY**

- *Travel allowance is limited to 300 miles maximum, or 7.5 hours maximum (per occurrence), **round trip**, and only applies to permanently wired and mounted units.
- All warranty expense allowances **are** subject to the conditions defined in Generac Power Systems Warranty, Policies, and Procedures Flat Rate Manual.
- *Travel allowance is limited to 300 miles maximum, or 7.5 hours maximum, round trip, to the nearest authorized Generac Service Facility.
- A Generac Power Systems, Inc. Transfer Switch is highly recommended to be used in conjunction with the genset. If a Non-Generac Power Systems, Inc. Transfer Switch is substituted for use and directly causes damage to the genset, no warranty coverage shall apply.
- Units that have been resold **are not** covered under the Generac Power Systems Warranty, as this Warranty **is not** transferable.

THIS WARRANTY SHALL NOT APPLY TO THE FOLLOWING:

1. Any unit built/manufactured prior to January 1, 2002.
2. Unit enclosure is only covered against rust or corrosion the first year of the warranty provision.
3. Costs of normal maintenance i.e. tune-ups, associated part(s), adjustments, loose/leaking clamps, installation and start-up.
4. Use of Non-Generac replacement part(s) will void the warranty in its entirety.
5. Any failure caused by contaminated fuels, oils, coolants/antifreeze or lack of proper fuels, oils or coolants/antifreeze.
6. Failures due, but not limited to, normal wear and tear, accident, misuse, abuse, negligence, or improper installation or sizing.
7. Failures caused by any external cause or act of God such as collision, fire, theft, freezing, vandalism, riot or wars, lightning, earthquake, windstorm, hail, volcanic eruption, water or flood, tornado, hurricane, terrorist acts or nuclear holocaust.
8. Products that are modified or altered in a manner not authorized by Generac Power Systems in writing.
9. Any incidental, consequential or indirect damages caused by defects in materials or workmanship, or any delay in repair or replacement of the defective part(s).
10. Failure due to misapplication, misrepresentation, or bi-fuel conversion.
11. Telephone, telegraph, teletype or other communication expenses.
12. Living or travel expenses of person(s) performing service, except as specifically included within the terms of a specific unit warranty period.
13. Rental equipment used while warranty repairs are being performed i.e. rental generators, cranes, etc.
14. Overtime labor or more than one person performing repairs.
15. Any and all expenses incurred investigating performance complaints unless defective Generac materials and or workmanship were the direct cause of the problem.
16. *Engine coolant heaters (block-heaters), heater controls and circulating pumps after the first year.
17. *Starting batteries, fuses, light bulbs, engine fluids, tires, brakes, and overnight freight cost for replacement part(s).

THIS WARRANTY IS IN PLACE OF ALL OTHER WARRANTIES, EXPRESSED OR IMPLIED, SPECIFICALLY, GENERAC POWER SYSTEMS MAKES NO OTHER WARRANTIES AS TO THE MERCHANTABILITY OR FITNESS FOR A PARTICULAR PURPOSE. Some states do not allow limitations on how long an implied warranty lasts, so the above limitation may not apply to you.

GENERAC POWER SYSTEMS ONLY LIABILITY SHALL BE THE REPAIR OR REPLACEMENT OF PART(S) AS STATED ABOVE. IN NO EVENT SHALL GENERAC POWER SYSTEMS BE LIABLE FOR ANY INCIDENTAL, OR CONSEQUENTIAL DAMAGES, EVEN IF SUCH DAMAGES ARE A DIRECT RESULT OF GENERAC POWER SYSTEMS, INC. NEGLIGENCE. Some states do not allow the exclusion or limitation of incidental or consequential damages, so the above limitations may not apply to you. Purchaser/owner agrees to make no claims against Generac Power Systems, Inc. based on negligence. This warranty gives you specific legal rights. You also may have other rights that vary from state to state.

GENERAC® POWER SYSTEMS, INC. · P.O. BOX 8 · WAUKESHA, WI 53187

PH: (262) 544-4811 · FAX: (262) 544-4851

Bulletin 0166250SBY / Printed in USA 5.02