

ONE-STOP

GENERAC

5.0/7.5 DIESEL

SERVICE REPAIR MANUAL

DESCRIPTION OF ENGINES MODELS

5.0 LITER

GENERAC #96383 = 7450Si10

GENERAC #92460 = 7450i10

7.5 LITER

GENERAC #92461 = 7675Si10

Page

GENERAL.....	1
DESCRIPTION AND OPERATION.....	5
FAULT FINDING	8
DISASSEMBLY AND OVERHAUL.....	13
ROCKER SHAFT	14
CYLINDER HEAD	14
VALVE INSERTS.....	16
VALVE GUIDES.....	18
VALVE SPRINGS.....	18
ROCKER SHAFT RE-ASSEMBLY.....	18
CYLINDER HEAD RE-ASSEMBLY.....	19
FRONT COVER AND TIMING GEAR REMOVAL.....	20
CAMSHAFT DRIVE GEAR.....	21
OIL PAN REMOVAL.....	23
CONNECTING RODS, BEARINGS, PISTONS, AND RINGS, REMOVAL.....	23
CONNECTING ROD BUSH.....	24
CILINDER BLOCK OVERHAUL.....	25
CYLINDER BORE.....	26
SLEEVING-BORING AND HONING.....	27
PISTON ASSEMBLY INSTALLATION INTO BLOCK.....	30
BALANCER	31
MAIN BEARING REMOVAL.....	32
FLYWHEEL REMOVAL.....	33
REAR COVER PLATE REMOVAL.....	33
OIL PUMP REMOVAL.....	35
OIL FILTER SUPPORT ASSEMBLY.....	37
CRANKSHAFT REMOVAL.....	37
BALANCER GEAR.....	38
CAMSHAFT REMOVAL.....	39
THERMOSTAT REMOVAL.....	41
WATER PUMP REMOVAL.....	42
FITTING TOLERANCES - DATA.....	46
TORQUE VALUES.....	55
INJECTORS.....	68
FUEL INJECTION PUMP.....	76

Page	
	GENERAL..... 2
	DESCRIPTION AND OPERATION..... 5
	FAULT FINDING 8
	DISASSEMBLY AND OVERHAUL..... 13
	ROCKER SHAFT 14
	CYLINDER HEAD 14
	VALVE INSERTS..... 16
	VALVE GUIDES..... 18
	VALVE SPRINGS..... 18
	ROCKER SHAFT RE-ASSEMBLY..... 18
	CYLINDER HEAD RE-ASSEMBLY..... 19
	FRONT COVER AND TIMING GEAR REMOVAL..... 20
	CAMSHAFT DRIVE GEAR..... 21
	OIL PAN REMOVAL..... 23
	CONNECTING RODS, BEARINGS, PISTONS, AND RINGS, REMOVAL..... 23
	CONNECTING ROD BUSH..... 24
	CILINDER BLOCK OVERHAUL..... 25
	CYLINDER BORE..... 26
	SLEEVING-BORING AND HONING..... 27
	PISTON ASSEMBLY INSTALLATION INTO BLOCK..... 30
	BALANCER..... 31
	MAIN BEARING REMOVAL..... 32
	FLYWHEEL REMOVAL..... 33
	REAR COVER PLATE REMOVAL..... 33
	OIL PUMP REMOVAL..... 35
	OIL FILTER SUPPORT ASSEMBLY..... 37
	CRANKSHAFT REMOVAL..... 37
	BALANCER GEAR..... 38
	CAMSHAFT REMOVAL..... 39
	THERMOSTAT REMOVAL..... 41
	WATER PUMP REMOVAL..... 42
	FITTING TOLERANCES - DATA..... 46
	TORQUE VALUES..... 55
	TURBOCHARGER..... 57
	INJECTORS..... 68
	FUEL INJECTION PUMP..... 76

Page	
	GENERAL..... 3
	DESCRIPTION AND OPERATION..... 5
	FAULT FINDING 8
	DISASSEMBLY AND OVERHAUL..... 13
	ROCKER SHAFT 14
	CYLINDER HEAD 14
	VALVE INSERTS..... 16
	VALVE GUIDES..... 18
	VALVE SPRINGS..... 18
	ROCKER SHAFT RE-ASSEMBLY..... 18
	CYLINDER HEAD RE-ASSEMBLY..... 19
	FRONT COVER AND TIMING GEAR REMOVAL..... 20
	CAMSHAFT DRIVE GEAR..... 21
	OIL PAN REMOVAL..... 23
	CONNECTING RODS, BEARINGS, PISTONS, AND RINGS, REMOVAL..... 23
	CONNECTING ROD BUSH..... 24
	CILINDER BLOCK OVERHAUL..... 25
	CYLINDER BORE..... 26
	SLEEVING-BORING AND HONING..... 27
	PISTON ASSEMBLY INSTALLATION INTO BLOCK..... 30
	MAIN BEARING REMOVAL..... 32
	FLYWHEEL REMOVAL..... 33
	REAR COVER PLATE REMOVAL..... 33
	OIL PUMP REMOVAL..... 35
	OIL FILTER SUPPORT ASSEMBLY..... 37
	CRANKSHAFT REMOVAL..... 37
	CAMSHAFT REMOVAL..... 39
	THERMOSTAT REMOVAL..... 41
	WATER PUMP REMOVAL..... 42
	FITTING TOLERANCES - DATA..... 46
	TORQUE VALUES..... 55
	INJECTORS..... 68
	FUEL INJECTION PUMP..... 76

Page	
	GENERAL..... 4
	DESCRIPTION AND OPERATION..... 5
	FAULT FINDING..... 8
	DISASSEMBLY AND OVERHAUL..... 13
	ROCKER SHAFT..... 14
	CYLINDER HEAD..... 14
	VALVE INSERTS..... 16
	VALVE GUIDES..... 18
	VALVE SPRINGS..... 18
	ROCKER SHAFT RE-ASSEMBLY..... 18
	CYLINDER HEAD RE-ASSEMBLY..... 19
	FRONT COVER AND TIMING GEAR REMOVAL..... 20
	CAMSHAFT/DRIVE GEAR..... 21
	OIL PAN REMOVAL..... 23
	CONNECTING RODS, BEARINGS, PISTONS, AND RINGS, REMOVAL..... 23
	CONNECTING ROD BUSH..... 24
	CILINDER BLOCK OVERHAUL..... 25
	CYLINDER BORE..... 26
	SLEEVING-BORING AND HONING..... 27
	PISTON ASSEMBLY INSTALLATION INTO BLOCK..... 30
	MAIN BEARING REMOVAL..... 32
	FLYWHEEL REMOVAL..... 33
	REAR COVER PLATE REMOVAL..... 33
	OIL PUMP REMOVAL..... 35
	OIL FILTER SUPPORT ASSEMBLY..... 37
	CRANKSHAFT REMOVAL..... 37
	CAMSHAFT REMOVAL..... 39
	THERMOSTAT REMOVAL..... 41
	WATER PUMP REMOVAL..... 42
	FITTING TOLERANCES - DATA..... 46
	TORQUE VALUES..... 55
	TURBOCHARGER..... 57
	INJECTORS..... 68
	FUEL INJECTION PUMP..... 76

ENGINE SPECIFICATIONS

Engine type.....7450110
 4 - stroke Diesel with direct injection
 Cylinders, number and arrangement.....4, in line
 Bore x stroke.....112 x 127 mm
 Displacement.....5 l
 Gross power (*).....67 KW(91 CV)
 At.....2200 rpm
 Engine rotation:
 (see from flywheel)CCW

* Duty according to DIN 70020

- Ambient reference conditions:
 760 mmHg; 20°C; 60% relative humidity

TIMING

Valve Timing:

- Intake:
 opens: before T.D.C12°
 closes: after B.D.C38°
 - Exhaust:
 opens: before B.D.C48°
 closes: after T.D.C12°

Operating clearance between valves and rockers, cold engine:
 - intake0,36 to 0,46 mm
 - exhaust.....0,43 to 0,53 mm

FUEL SYSTEM

Rotary injection pump type CAV

Fuel injectors setting.....240 ± 3 bar
 Firing order.....1-3-4-2

LUBRICATION

Minimum oil pressure:

- at full throttle.....2.3 Kg/cm²
 - when idling.....1 kg/cm²

COOLING SYSTEM

Forced water circulation controlled by centrifugal pump.
 Water temperature controlled by thermostat.
 Radiator cooling fan drive by V-belt.

STARTING

By starter motor.

ELECTRIC SYSTEM

- Voltage.....12 V
 - Self-regulated alternator.....14 V, 45 A
 - Starting motor power.....3 KW
 - Battery (optional).....1 x 150 Ah

ENGINE SPECIFICATIONS

Engine type7450SI10
 4 - stroke Diesel with direct injection
 Cylinders, number and arrangement.....4, in line
 Bore x stroke.....112 X 127 mm
 Displacement.....5 l
 Gross power(*).....88 kW(120 CV)
 At.....2100 rpm
 Engine rotation:
 (see from flywheel)CCW

* Duty according to DIN 70020

- Ambient reference conditions:
 760 mmHg; 20°C; 60% relative humidity

TIMING

Valve Timing:

- Intake:
 opens: before T.D.C12°
 closes: after B.D.C38°
- Exhaust:
 opens: before B.D.C48°
 closes: after T.D.C12°

Operating clearance between valves and rockers, cold engine;

- intake.....0,36 to 0,46 mm
- exhaust.....0,43 to 0,53 mm

FUEL SYSTEM

Rotary injection pump type CAV.

Fuel injectors setting240 ± 3 bar
 Firing order.....1-3-4-2

TURBOCHARGING

The engine is supercharged by a turbocharger driven by the exhaust gases.

The turbocharger is lubricated with the engine oil under pressure.

LUBRICATION

Minimum oil pressure:

- at full throttle.....2,3 Kg/cm²
- when idling.....1 Kg/cm²

COOLING SYSTEM

Forced water circulation controlled by centrifugal pump.

Water temperature controlled by thermostat.

Radiator cooling fan driven by V-belt.

STARTING

By starter motor.

ELECTRIC SYSTEM

- Voltage.....12 V
- Self-regulated alternator.....14 V, 45 A
- Starting motor power.....3 kW
- Battery (optional).....1 X 150 Ah

ENGINE SPECIFICATIONS

Engine type.....7675I10
 4 - stroke Diesel with direct injection
 Cylinders, number and arrangement.....6, in line
 Bore x stroke.....112 x 127 mm
 Displacement.....7,5 l
 Gross power (*).....93 kW(126 CV)
 At.....2100 rpm
 Engine rotation:
 (see from flywheel)CCW

* Duty according to DIN 70020
 - Ambient reference conditions:
 760 mmHg; 20°C; 60% relative humidity

TIMING

Valve Timing:

- Intake:
 opens: before T.D.C12°
 closes: after B.D.C38°
 - Exhaust:
 opens: before B.D.C48°
 closes: after T.D.C12°

Operating clearance between valves and rockers, cold engine:
 - intake0,36 to 0,46 mm
 - exhaust.....0,43 to 0,53 mm

FUEL SYSTEM

Rotary injection pump type CAV

Fuel injectors setting.....290 ± 3 bar
 Firing order.....1-5-3-6-2-4

LUBRICATION

Minimum oil pressure:
 - at full throttle.....2.3 kg/cm²
 - when idling.....1 kg/cm²

COOLING SYSTEM

Forced water circulation controlled by centrifugal pump.
 Water temperature controlled by 2 thermostats.
 Radiator cooling fan drive by V-belt.

STARTING

By starter motor.

ELECTRIC SYSTEM

- Voltage.....12 V
 - Self-regulated alternator.....14 V, 45 A
 - Starting motor power.....3 kW
 - Battery (optional).....1 x 150 Ah

ENGINE SPECIFICATIONS

Engine type.....	7675Si10
4 - stroke Diesel with direct injection	
Cylinders, number and arrangement.....	6, in line
Bore x stroke.....	112 X 127 mm
Displacement.....	7,5 l
Gross power(*).....	125 kW(170 CV)
At.....	2100 rpm
Engine rotation:	
(see from flywheel)	CCW

* Duty according to DIN 70020

- Ambient reference conditions:
760 mmHg ; 20°C; 60% relative humidity

TIMING

Valve Timing:

- Intake:
opens: before T.D.C12°
closes: after B.D.C38°
- Exhaust:
opens: before B.D.C48°
closes: after T.D.C12°

Operating clearance between valves and rockers, cold engine;

- intake.....0,36 to 0,46 mm
- exhaust.....0,43 to 0,53 mm

FUEL SYSTEM

Rotary injection pump type CAV

Fuel injectors setting	290 ± 3 bar
Firing order.....	1-5-3-6-2-4

TURBOCHARGING

The engine is supercharged by a turbocharger driven by the exhaust gases.

The turbocharger is lubricated with the engine oil under pressure.

LUBRICATION

Minimum oil pressure:

- at full throttle.....2,3 kg/cm²
- when idling.....1 kg/cm²

COOLING SYSTEM

Forced water circulation controlled by centrifugal pump.
Water temperature controlled by 2 thermostats.
Radiator cooling fan driven by V-belt.

STARTING

By starter motor.

ELECTRIC SYSTEM

- Voltage.....12 V
- Self-regulated alternator.....14 V, 45 A
- Starting motor power.....3 kW
- Battery (optional).....1 X 150 Ah

DESCRIPTION AND OPERATION

This chapter describes the overhaul and repair of the new series, direct injection diesel engines.

These engines are available in 4 or 6 cylinder naturally aspirated and turbocharged form.

As these engines are of similar design and service procedures are common throughout the range. The 4 cylinder engines have a design difference in that they are fitted with a dynamic balancer assembly.

All engines feature cross flow cylinder heads, with the inlet and exhaust manifolds on opposite sides of the cylinder head. The fuel and air combustion process, takes place in the specially designed bowl in the crown of the pistons.

CYLINDER HEAD ASSEMBLY

The cylinder head incorporates valves and springs with the valve rocker arm shaft assembly bolted to the cylinder block through the cylinder head. Cylinder head retaining bolts are evenly spaced with a six point pattern around each cylinder, this ensures an even clamping load across the cylinder head area.

The intake and exhaust manifolds are bolted to the head. The intake manifold is mounted on the right hand side of the engine with the diesel injectors mounted outside the rocker cover. The exhaust manifold is mounted on the left hand side of the engine, water outlet connections and thermostat being attached to the front of the cylinder block.

Valve guides are integral in the cylinder head and valves with oversize stems are available in service. Special replaceable cast alloy valve seats are pressed into each valve port during manufacture, with oversize valve seats also available in service.

All valves are fitted with positive valve rotators, with both Intake and exhaust valves using umbrella type oil seals. Valve lash is maintained by adjustment of the self locking adjusting screw, mounted in each of the rocker arms.

CAMSHAFT ASSEMBLY

The camshaft runs in replaceable bearings, with 3 fitted in the 4 cylinder and 5 fitted in the 6 cylinder. The camshaft drive gear is in mesh with, and driven by the camshaft idler gear and crankshaft timing gear.

Camshaft end thrust is controlled by a thrust plate bolted to the block and located between the camshaft gear and the front camshaft journal.

A helical gear is mounted on the rear of the camshaft and drives the engine oil lubrication pump mounted forward of the flywheel.

CRANKSHAFT ASSEMBLY

The crankshaft is supported in the cylinder block by 5 main bearings on the 4 cylinder engine and 7 main bearings, on the 6 cylinder engine.

End thrust is controlled by a thrust bearing incorporated in the centre main bearing of the crankshaft.

A crankshaft driven dynamic balancer is installed on the 4 cylinder engines to ensure smooth running performance during their working life. The balancer assembly is bolted to the bottom of the cylinder block and contains two meshing weighted gears. These are driven and timed from a gear heat shrunk to the crankshaft.

In addition to the internal balancer, a damper is also fitted externally to the crankshaft pulley. The six cylinder engine requires only this external damper to ensure smooth running operation. Front and rear crankshaft oil sealing is effected by one piece seals that are designed for long and durable service life.

CONNECTING RODS

Connecting rods "Teepee" (wedge) shaped at the small end have been designed to reduce the reciprocating weight at the piston end. The connecting rods are of a heavy beam construction and are assembled as a matched set to each engine, attached to the crankshaft, by means of insert-type copper/lead or aluminium tin alloy bearings.

They are retained in position by the connecting rod big end cap and secured by two bolts per rod. The small end of the connecting rod is fitted with a replaceable bronze bushing, through which the free floating piston pin is fitted. The steel pin being held in place within the piston by two snap rings.

PISTONS

Pistons of increased weight and strength, are constructed of an aluminium silicon alloy with an iron insert for the top ring. The combustion chamber being recessed into the piston crowns.

Each piston has two compression rings and one oil control ring, to reduce friction and increase positive sealing. All rings are located above the piston pin.

MANIFOLDS

The cross flow design aluminium intake, and cast iron exhaust manifolds, are on opposite sides of the cylinder head. This is designed to maintain balanced heat distribution within the cylinder head. The configuration of the manifolds also ensures minimum heat transfer to the intake manifold.

CYLINDER BLOCK ASSEMBLY

The cylinder block is an alloy cast iron with deep cylinder skirts, and water jackets for cooling the cylinders. The cylinder bores are machined integral with the cylinder block, during the manufacturing process.

Cylinders are in line and vertical and numbered from 1 to 4 or 6, from the front to the rear of the engine. They can be bored oversize for the fitment of sleeves or oversize pistons, which are available in service.

The oil pan which is attached to the bottom of the cylinder block, is the reservoir for the engine oil lubrication system. An aluminium engine front cover is attached to the front engine adapter plate and covers all of the timing gear assembly.

TIMING GEARS

The crankshaft timing gear is heated and press fitted on to the front of the crankshaft, to a high degree of accuracy during manufacturing. This enables precise timing being maintained during the life of the engine.

The crankshaft gear drives the camshaft idler gear which is attached to the front of the cylinder block. The idler gear then drives the camshaft and the injection pump via meshing helical gears.

The camshaft gear is bolted to the front of the camshaft, and is keyed to maintain position of the gear on the camshaft. All gears can be checked for timing by observing the punch marks on the gears.

LUBRICATION SYSTEM

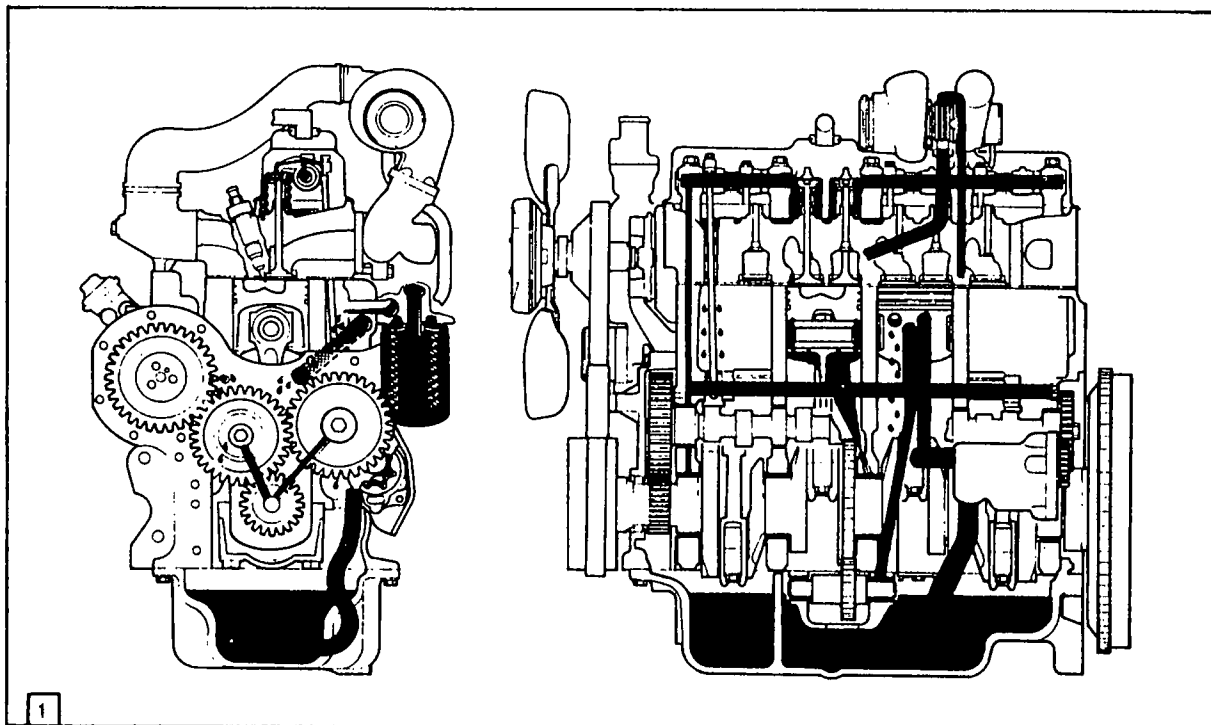

1

Engine Lubrication System With Turbocharger Fitted

Engine Oil Flow



Lubrication of the engine, Figure 1, is maintained by a rotor type oil pump mounted in the rear of the engine block, forward of the fly-wheel on the left hand side of the engine. The oil pump is driven from the rear of the camshaft and draws oil from the engine oil pan through a tube and screen assembly.

A spring loaded relief valve is integral with the oil filter body mounted on the left hand side of the engine block and prevents over-pressurisation of the system.

The spin on type oil filter mounted externally to its support housing on the left hand side of the engine, allows easy access at service intervals. Oil flows from the filter to the main oil gallery which runs the length of the cylinder block, which also intersects the camshaft follower chamber.

The main gallery also supplies oil to the crankshaft main bearings, connecting rods, big ends and small ends. The underside of the pistons and pins, are lubricated by oil pressure jets mounted adjacent to each main journal housing.

Timing gears are lubricated by splashed oil from the cam follower chamber and the pressure lubricated camshaft drive gear bushing.

On 4 cylinder engines the dynamic balancer is lubricated, through a drilled passage, from the cylinder block crankshaft thrust bearing web to the balancer housing. Oil flows through the balancer housing to the drilled balancer gear shafts and onto the bushings in the balancer gears.

An intermittent flow of oil is directed to the valve rocker arm shaft assembly via a drilled passage in the cylinder block. This is located vertically above above No.1 camshaft bearing and aligns to a hole in the cylinder head. The rotation of the camshaft allows a controlled intermediate flow of lubrication.

The turbocharger where fitted, is supplied with oil from the oil filter support housing mounted on the left hand side of the engine.

FAULT FINDING

IMPORTANT: *When effecting a repair the cause of the problem must be investigated and corrected to avoid repeat failures.*

The following table lists problems and their possible causes with recommended remedial action.

PROBLEM	POSSIBLE CAUSES	REMEDY
Engine does not-develop full power	<ol style="list-style-type: none"> 1. Clogged air cleaner 2. Fuel line obstructed 3. Faulty injectors 4. Incorrect valve lash adjustment 5. Burnt, worn or sticking valves 6. Blown head gasket 7. Incorrect fuel delivery 8. Low cylinder compression 	<ol style="list-style-type: none"> 1. Clean or renew element 2. Clean 3. Clean and reset 4. Check and reset 5. Replace valves with new or oversize and/or machine the valve guide bores 6. Check head flatness and fit new gasket 7. Check injectors and pump 8. Renew piston rings or re-bore/re-sleeve as necessary
Engine knocks	<ol style="list-style-type: none"> 1. Diluted or thin oil 2. Insufficient oil supply 3. Low oil pressure 4. Excessive crankshaft end play 5. Flywheel or ring gear run-out excessive 6. Excessive connecting rod or main bearing clearance 	<ol style="list-style-type: none"> 1. Check crankshaft bearings for damage, change as required. Drain and refill with specified oil and renew filter. Ascertain cause of dilution 2. Check oil level and top up as necessary. Overhaul or renew pump as necessary. Check oil filter is not clogged 3. Overhaul pump or relief valve as necessary 4. Install new thrust bearing liner 5. Skim flywheel or fit new ring gear 6. Install new bearing inserts and/or re-grind crankshaft

PROBLEM	POSSIBLE CAUSES	REMEDY
	<ul style="list-style-type: none"> 7. Bent or twisted connecting rods 8. Crankshaft journals out-of-round 9. Excessive piston-to-cylinder bore clearance 10. Excessive piston ring clearance 11. Broken rings 12. Excessive piston pin clearance 13. Piston pin retainer loose or missing 14. Excessive camshaft play 15. Imperfections on timing gear teeth 16. Excessive timing gear backlash 	<ul style="list-style-type: none"> 7. Renew connecting rods 8. Re-grind crankshaft and fit undersize bearing inserts 9. Re-bore/re-sleeve block and fit new pistons 10. Fit new pistons and rings 11. Fit new rings, check bore and pistons for damage 12. Fit new piston or pin 13. Install new retainer and check bore/pistons for damage 14. Install new thrust plate 15. Renew timing gear 16. Renew timing gear
<p>Engine overheats</p>	<ul style="list-style-type: none"> 1. Hose connection leaking or collapsed 2. Radiator cap defective or not sealing 3. Radiator leakage 4. Improper fan belt adjustment 5. Radiator fins restricted 6. Faulty thermostat 	<ul style="list-style-type: none"> 1. Tighten hose connection, renew hose if damaged 2. Renew radiator cap 3. Repair/renew radiator 4. Re-adjust fan belt 5. Clean with compressed air 6. Renew thermostat

PROBLEM	POSSIBLE CAUSES	REMEDY
	<ul style="list-style-type: none"> 7. Internal engine leakage 8. Water pump faulty 9. Exhaust gas leakage into cooling system 10. Coolant aeration 11. Cylinder head gasket improperly installed 12. Hot spot due to rust and scale or clogged water jackets 13. Obstruction to radiator air flow 14. Extended engine idling 15. Oil cooler tube blocked 16. Radiator core tubes blocked 	<ul style="list-style-type: none"> 7. Check for source of leakage, renew gasket or defective parts 8. Overhaul water pump 9. Renew cylinder head gasket, check head for damage or distortion 10. Tighten all connections and check coolant level is correct. Ensure cylinder head gasket has not blown 11. Renew cylinder head gasket 12. Reverse flush entire cooling system 13. Remove the obstruction 14. Do not allow engine to idle for long periods 15. Clean 16. Check free flow
<p>Low oil pressure</p>	<ul style="list-style-type: none"> 1. Engine oil level low 2. Wrong grade of oil 3. Blocked oil pump sump screen 4. Oil pressure relief valve faulty 5. Oil pump worn 6. Excessive oil pump rotor and shaft assembly clearance 	<ul style="list-style-type: none"> 1. Top up as necessary 2. Drain and refill with correct grade of oil 3. Clean pump screen 4. Fit new relief valve 5. Renew Oil Pump 6. Overhaul pump

PROBLEM	POSSIBLE CAUSES	REMEDY
	7 Excessive main or connecting rod bearing clearance	7. Install new bearings inserts and / or re-grind crankshaft
Excessive oil consumption	1. Engine oil level too high 2. External oil leaks 3. Worn valves, valve guides or bores 4. Cylinder head gasket leaking 5. Oil loss past the pistons and rings 6. Oil cooler leak	1. Reduce oil level 2. Renew gaskets and seals where necessary. Check mating surfaces for damage or distortion 3. Renew 4. Renew gasket. Check head for damage or distortion 5. Renew rings and/or re-bore/ re-sleeve block as necessary 6. Repair/renew oil cooler assembly
Engine tends to keep firing after fuel is shut off	1. Air cleaner dirty or restricted 2. Oil leak on compressor side of turbocharger where fitted	1. Clean or renew element 2. Overhaul turbocharger
Excessive exhaust smoke	1. Oil leak on compressor or turbine side of turbocharger where fitted 2. Exhaust leak on exhaust manifold side of turbocharger where fitted 3. Air cleaner dirty or restricted 4. Excessive fuel delivery	1. Overhaul turbocharger 2. Fit new gasket 3. clean 4. Overhaul injection pump and injectors

PROBLEM	POSSIBLE CAUSES	REMEDY
Water temperature gauge fails to reach normal operating temperature	<ol style="list-style-type: none">1. Faulty temperature sender2. Incorrect or faulty thermostat3. Faulty water temperature gauge	<ol style="list-style-type: none">1. Renew sender switch2. Renew thermostat3. Renew temperature gauge

DISASSEMBLY AND OVERHAUL

Dismantle the engine following conventional techniques, or by referring to the following removal procedure, referring to the "Specification" section as necessary.

NOTE: All gaskets, seals and 'O' rings must be replaced with new, upon re-assembly.

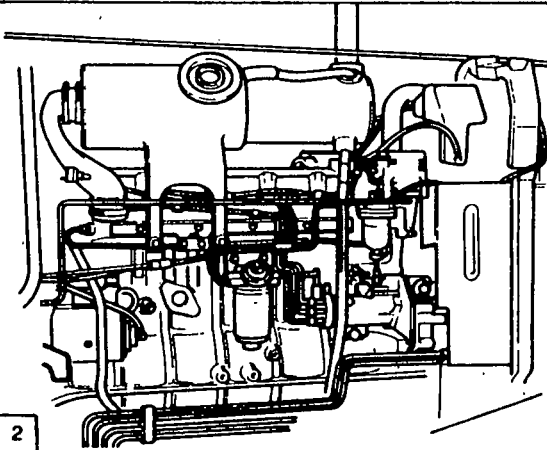

Right Hand View of Engine

Disconnect and remove injector fuel pipes from the fuel injection pump (cap all exposed openings).

Disconnect thermostat fuel pipe on the intake manifold (cap exposed opening).

Disconnect and remove the rocker cover ventilation tube.

Remove the alternator.

Disconnect all loom connections on engine harness and secure clear of the engine.

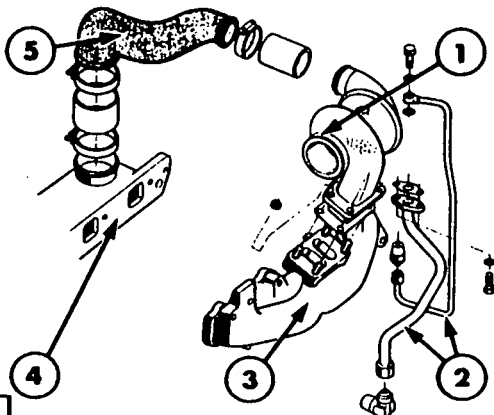

Turbocharger Assembly

- 1. TurboCharger Housing
- 2. Oil Feed/Return Tubes
- 3. Exhaust Manifold
- 4. Inlet Manifold
- 5. Inlet Hoses/Tubes

Remove the turbocharger assembly, Figure 3, ensuring all openings are capped to prevent dirt ingress.

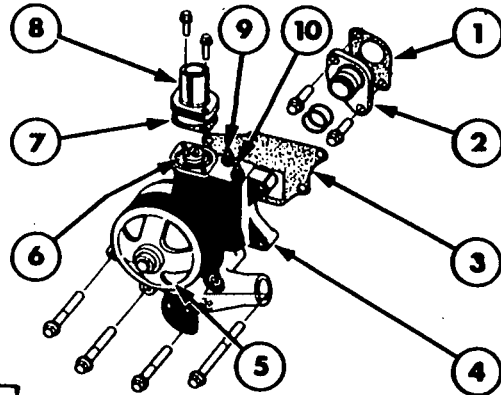

Water Pump Assembly

- 1. Gasket
- 2. Connector & 'O' rings
- 3. Pump Gasket
- 4. Pump Body
- 5. Pulley Assembly
- 6. Thermostat
- 7. Gasket
- 8. Thermostat Housing
- 9. Temperature Sender
- 10. Temperature Sender

Where applicable remove the water pump from the engine, Figure 4.

Remove the water pump connector from the engine cylinder head.

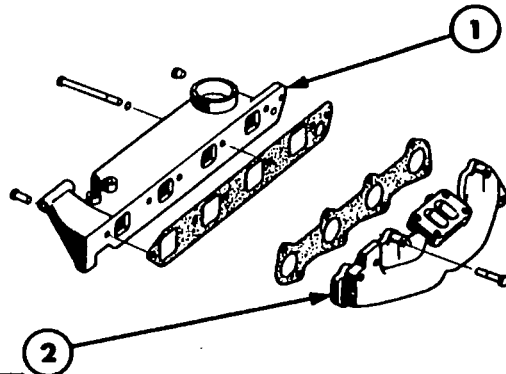

Manifold Assembly

- 1. Inlet Manifold
- 2. Exhaust Manifold

Loosen and remove the manifold bolts and remove the exhaust manifold and gasket. Repeat for the inlet manifold and gasket, Figure 5.

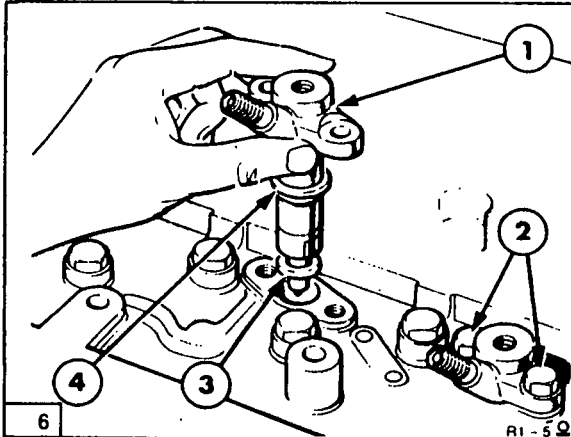

Injector Removal

1. Fuel Injector	3. Copper Washer
2. Mounting Bolts	4. Cork Washer

19. Clean area surrounding the fuel injectors, hold leak off pipe at each injector and carefully disconnect, Figure 6.

20. Remove the rocker cover and gasket.

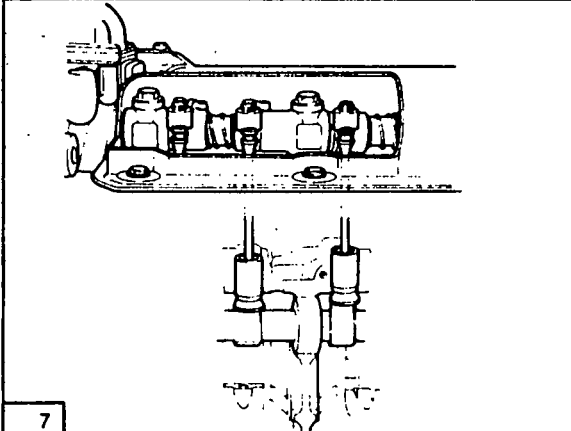

Push Rod Installation

21. Check push rods for concentricity, by rotating the rods with the valve closed and identify any bent rods, Figure 7.

ROCKER SHAFT

NOTE: Leave bolts in the rocker shaft supports during removal as they retain the support on the shaft.

1. Remove the cylinder head bolts which pass through the rocker shaft supports, Figure 8.

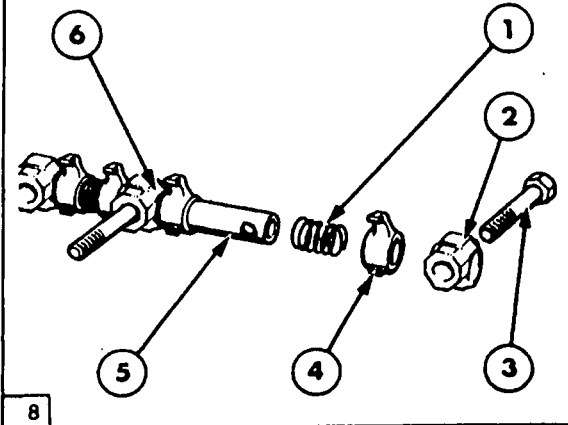

Rocker Shaft Assembly

1. Spring	4. Rocker Arm
2. Shaft Support	5. Shaft
3. Retaining Bolt	6. Spacer

2. Loosen the rocker shaft retaining bolts, which also serve as head bolts evenly and alternately and remove the rocker shaft assembly.
3. Remove push rods in turn and place in a numbered rack to maintain the same position for re-assembly.
4. Remove remaining cylinder head bolts working inwards from the end of the cylinder head, alternately to the centre of the cylinder head.

CYLINDER HEAD

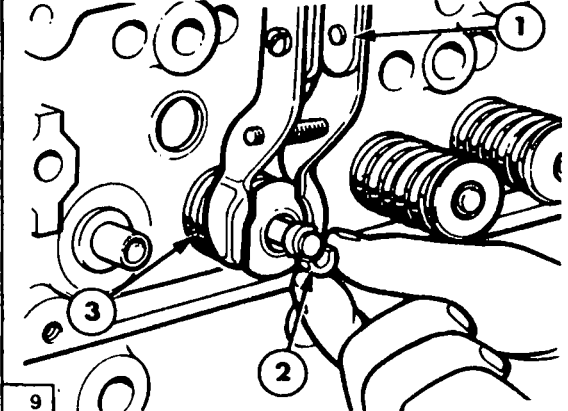

Valve Removal

1. Valve Spring Compressor	2. Retainer Locks
	3. Valve Springs

1. Using a valve spring compressor remove the retainer locks, springs, seals and rotators and place in a numbered rack, Figure 9.
2. Clean the cylinder head and remove carbon deposits from around the valve heads.

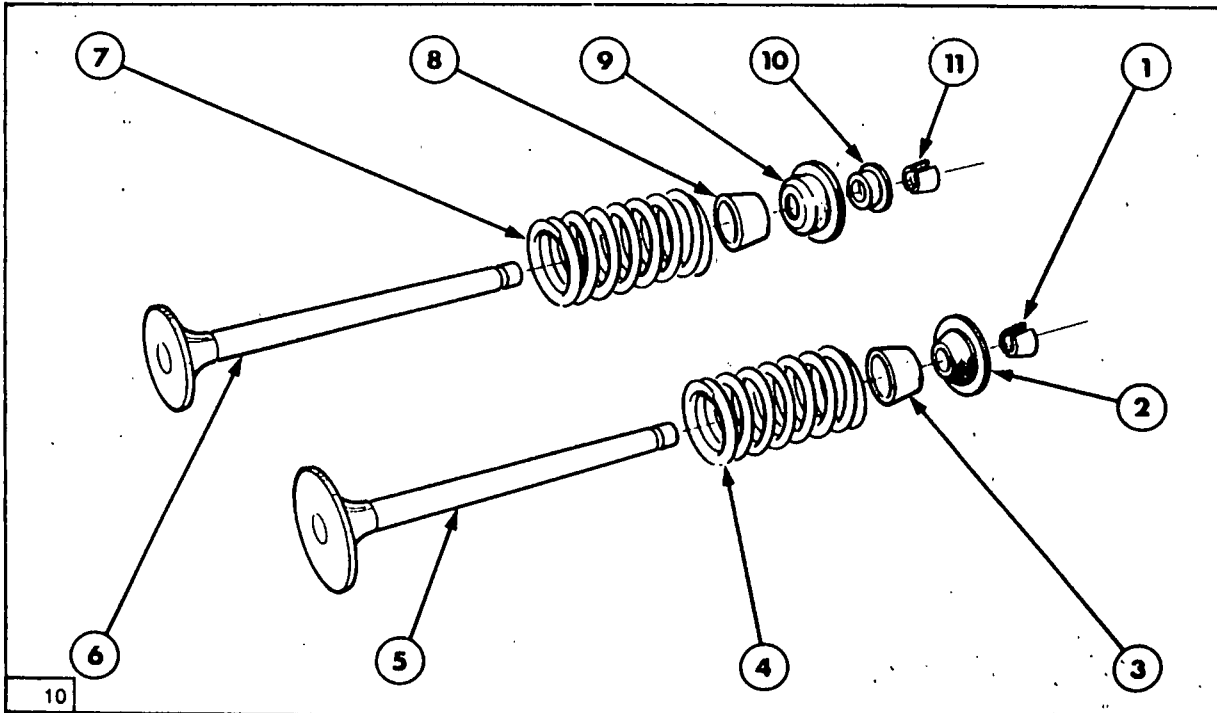

10

Valve Assemblies

Intake Valve

- 1. Valve Spring Lock
- 2. Spring Rotator
- 3. Seal
- 4. Spring
- 5. Valve

Exhaust Valve

- 6. Valve
- 7. Spring
- 8. Seal
- 9. Spring Rotator
- 10. Spring Rotator
- 11. Valve Spring Lock

Inspection and Repair, Cylinder Head

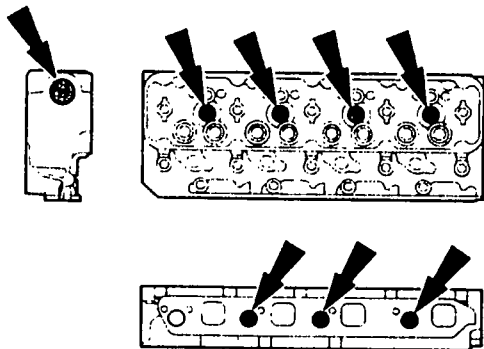

11

R1-9

Core Plug Installation

1. Cylinder head core plugs if discoloured (rusty), or leaking require changing. Before fitting new plugs remove all old sealer from the cylinder head. Apply sealant G, see "Specifications", to the new plug mating faces, and drive the new plugs into location, Figure 11.

Core plugs required, 4 Cylinder Head:-

4 off, in the top and 1 off, in the rear of the cylinder head.
3 off, in the Intake face.

Core plugs required, 6 Cylinder Head:-

6 off, In the top and 1 off, in the rear of the cylinder head.
5 off, in the intake face.

2. Scrape all gasket surfaces clean and wash cylinder head in a suitable solvent, also cleaning valve guide bores.

NOTE: Ensure injector washers have been removed prior to cleaning.

3. Inspect cylinder head for nicks and burrs on mating face remove using a suitable abrasive and ensure faces are clean after repair.

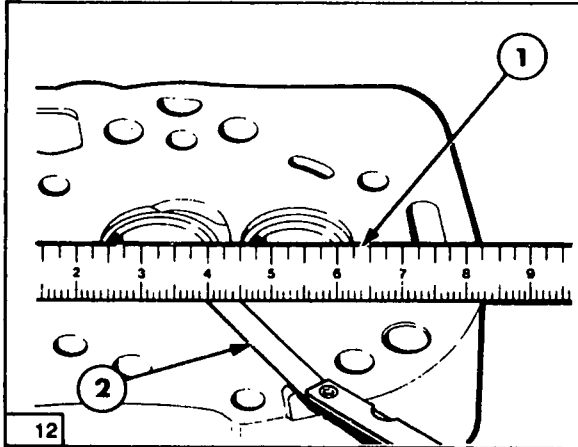

Cylinder Head Flatness

1. Straight Edge 2. Feeler Gauge

4. Using a special tool with a straight edge and feeler gauges, check flatness of cylinder head in all directions does not exceed, 0.001 in (0.03mm) in any 1 in (25.4mm), or 0.005 in (0.127mm) overall limit, Figure 12.
5. If the cylinder head has been resurfaced, determine that all head bolt faces will seat by placing the cylinder head less gasket, on the cylinder block and installing the cylinder head bolts hand tight.
6. Ensure rocker shaft supports are fitted with long bolts. Using a feeler gauge, check clearance between underside of bolt heads and cylinder head or rocker shaft support.

7. If a 0.010 in (0.25mm) feeler gauge can be inserted under the bolt head the bolt has bottomed. Therefore the cylinder block thread must be increased using a 9/16-13 UNC-2A Thread tap. Identify the bolt heads and ensure they are reinstalled in the bolt holes they were checked in.

VALVE INSERTS

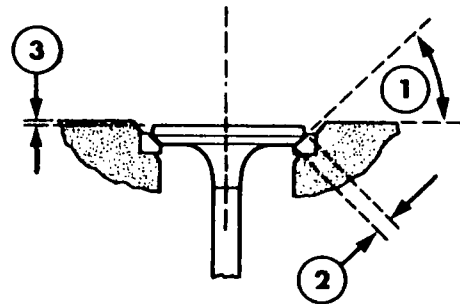

Valve Seat Dimensions

1. Valve Seat Angle
2. Valve Seat Width
3. Valve Head Face to Cylinder Head Depth

NOTE: Refacing the valve seat should always be co-ordinated with refacing of the valve to ensure a compression tight fit.

1. Examine the valve seat inserts and reface if pitted, renew if loose or damaged.
2. To install a new valve insert, the cylinder head must be counter bored, as dimensioned in the chart below. The new insert must be chilled in dry ice prior to installation.

Insert Oversize	Counter Bore in Cylinder Head	
	Exhaust valve insert	Intake valve insert
0.010 in (0.25mm)	1.739-1.740 in (44.17-44.20mm)	1.969-1.970 in (50.01-50.04mm)
0.020 in (0.58mm)	1.749-1.750 in (44.42-44.45mm)	1.979-1.980 in (50.27-50.29mm)
0.030 in (0.76mm)	1.759-1.760 in (44.68-44.70mm)	1.989-1.990 in (50.52-50.55mm)

Valve Seat Specifications, Figure 13.

1, Valve seat angle:-

- Intake = 30.0°-30.30°
- Exhaust = 45.0°-45.30°

2, Valve seat width:-

- Intake = 0.078-0.098 in (1.9-2.4mm)
- Exhaust = 0.072-0.092 in (1.8-2.3mm)

3, Valve head face to cylinder head face depth:-

- Intake = 0.034-0.052 in (0.86-1.32mm)
- Exhaust = 0.047-0.065 in (1.2-1.6mm)

NOTE: Valve inserts of 0.010 in (0.25mm) and 0.020 in (0.5mm) oversize on diameter are sometimes installed during manufacture. Cylinder Heads with oversize inserts are stamped so10/os, so20/os, on the exhaust manifold side in line with the valve seat concerned.

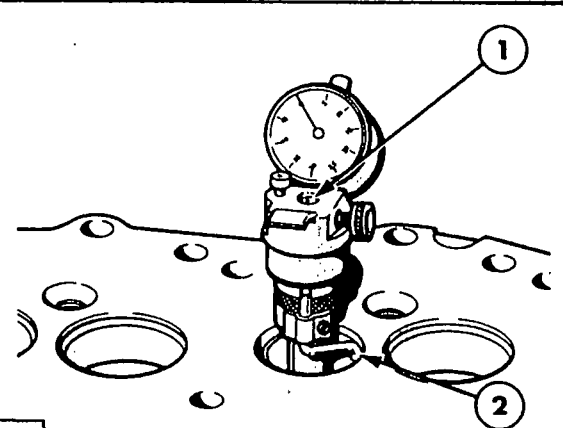

14

R1 - 12 Ω

Valve Seat Concentricity

1. Dial Indicator
2. Measuring Probe
3. Check the width of the valve seat inserts and as required reface by grinding to dimensions, Figure 13.
4. Measure the concentricity of valve seats, using a dial indicator and measure concentricity of seat to the valve guide bore. Total Indicator Reading should not exceed 0.002 in (0.051mm), Figure 14.
5. Use a seat cutter to correct any seat eccentricity or clean up of pits and grooves. Ensure after any rework that seat width is within specified limits, Figure 13.

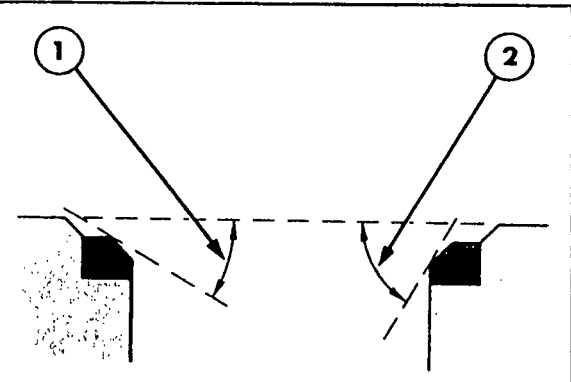

15

R1 - 13 Ω

Raising and Lowering of Valve Seats

1. Lowering the Valve Seat
2. Raising the Valve Seat
6. Rotate a new or refaced valve in the seat using engineering blue, ensure all the blue is transferred to the valve head protrusion if any blue remains below or around the seat, raise or lower the seat accordingly, Figure 15, in the following manner.

Lower the valve seats by removing material from the top of seat using a:-
30° grinding wheel for, Exhaust valves and a 15° grinding wheel for, Intake valves.

Raise the valve seats by removing material from the bottom of seat using a:-
60° grinding wheel for Exhaust valves and a 45° grinding wheel for Intake valves.

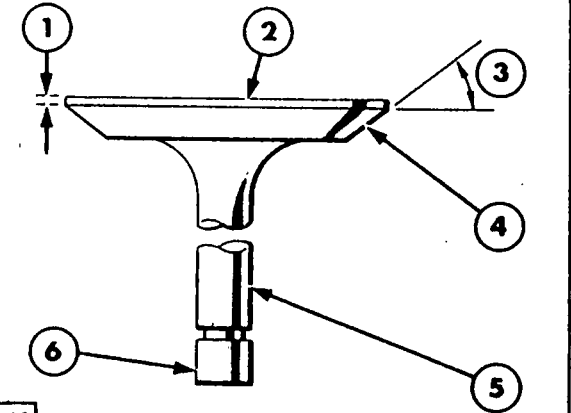

16

R1 - 14 Ω

Critical Valve Points

- | | |
|---------------------|---------------|
| 1. Valve Land Edge | 4. Valve Face |
| 2. Valve Head | 5. Valve Stem |
| 3. Valve Face Angle | 6. Valve Tip |

VALVE GUIDES

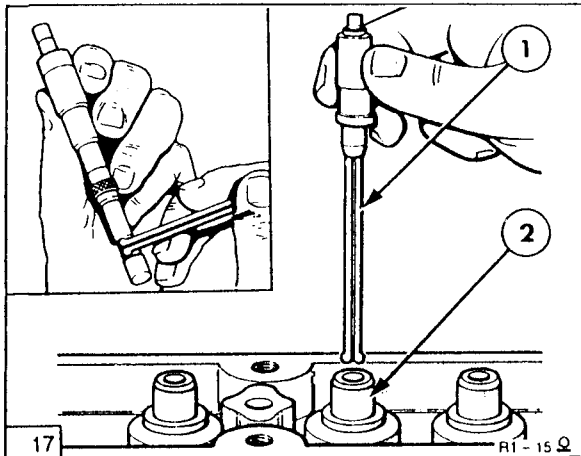

Measuring the Valve Guide Bore

1. Telescopic Gauge 2. Valve Guide Bore
- Using a telescopic gauge and micrometer, measure the valve guide bore clearance and ensure it does not exceed 0.0009–0.0027 in (0.023–0.069mm) on the intake valve stem, 0.0019–0.0037 in (0.048–0.094mm) on the exhaust valve stem, Figure 17.

NOTE: Production cylinder heads may have one or more machined, oversize valve guide bores or valves installed 0.015 in (0.38mm). Such cylinder heads have 15 or VO15OS stamped on the cylinder head exhaust manifold side adjacent to the valve concerned.

- Using a suitable reamer, ream out the valve stem guide with three reamer and pilot combinations as follows:—

0.003 in (0.076mm) oversize reamer and standard diameter pilot.

0.015 in (0.38mm) oversize reamer and 0.003 in (0.076mm) oversize pilot.

0.030 in (0.76mm) oversize reamer and 0.015 in (0.38mm) oversize pilot.

- When going from a standard valve stem to an oversize, always use reamers in sequence.

VALVE SPRINGS

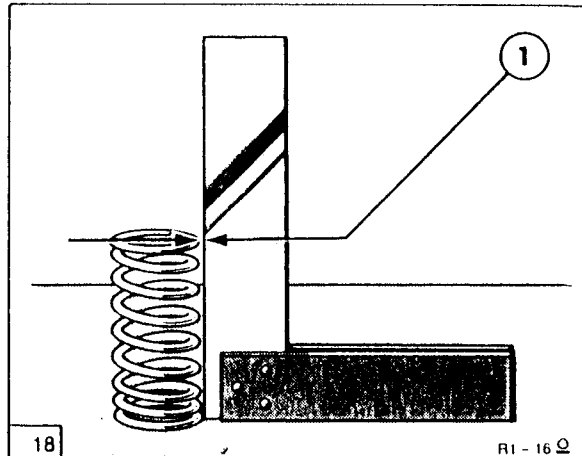

Valve Spring Squareness

- Measuring spring squareness
- Checked on a flat surface squareness, should not exceed 0.060 in (1.52mm), between the square and spring at the top edge, Figure 18.

Length of valve springs should be checked on both free length and loaded length.

Free length = 2.39 in (60.7mm)

Installed length = 1.86–1.95 in (47–49.6mm)

Loaded length = 1.9 in (48.26mm) using a weight of 61.96 lb (28–31 kg)

Loaded length = 1.4 in (35.69mm) using a weight of 135–153 lb (61–69 kg)

Ensure the valve spring retainer locks are in good condition and replace if worn or damaged.

ROCKER SHAFT RE-ASSEMBLY

- Check the rocker shaft for signs of wear or damage on internal and external diameters respectively. If not to specification replace with new. If re-used, before reassembly clean thoroughly in solvent making sure all oil passages are clear.
- Position the shaft identification groove forwards and upwards. This ensures oil grooves and holes face downwards.

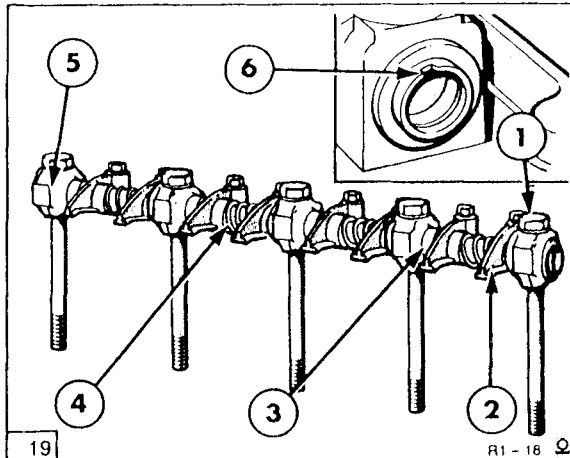

19

R1-18

Rocker Shaft Assembly

- | | |
|---------------|-----------------------------|
| 1. Bolts | 5. Rocker Arm Shaft Support |
| 2. Rocker Arm | 6. Groove at Front of Shaft |
| 3. Spacer | |
| 4. Spring | |
3. Assemble rocker shaft support with long head bolts, ensuring springs and spacers are re-assembled as in, Figure 19.

ROCKER SHAFT INSTALLATION

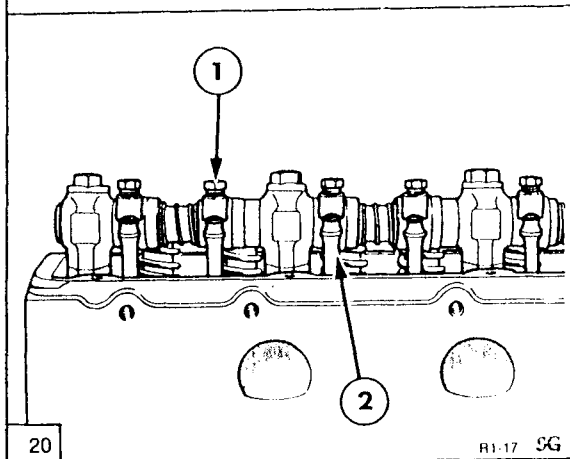

20

R1-17 SG

Rocker Shaft Assembly

- | |
|-------------------------------|
| 1. Rocker Arm Adjusting Screw |
| 2. Push Rod |
1. Inspect rocker arm adjusting screws, and push rod ends of the rocker arm, including the ball end of the screws for nicks, damage, or excessive wear, Figure 20.
 2. Also inspect the inside diameter of the rocker arm for damage or wear. If any of these characteristics are not to specification replace with new parts.
 3. Check the ends of the push rods for damage or wear. If not to specification or push rods were found not to be straight during dismantling install new rods.

NOTE: Do not attempt to straighten bent push rods, replace with new.

CYLINDER HEAD RE-ASSEMBLY

1. Insert the valves into the guide bores from which they were removed and lap with a suitable paste, ensure all traces of paste are removed after lapping.
2. Lubricate all components with clean engine oil on re-assembly. Use a spring compressor to reassemble the valves, valve springs, retainers, rotators, and collets, and install new umbrella seals.
3. Coat all components with clean engine oil prior to assembly, and insert each push rod into its original position, ensuring each ball end is seated in its cam follower, Figure 20.

CYLINDER HEAD INSTALLATION

Installation of the cylinder head assembly and components is the reverse of the removal procedure, observing the following,

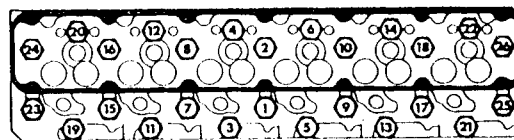
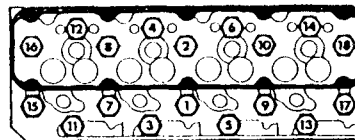

21

R1-19

Cylinder Head Bolt Tightening Sequence

1. Install new cylinder head, intake and exhaust manifold gaskets, Figure 21.

NOTE: Ensure exhaust manifold gasket is fitted correctly to suit profile of exhaust ports.

2. Tighten the cylinder head bolts in sequence progressively in three stages, Figure 21.

Stage1, 115 lbf ft (156N m) 15.6 kgf m

Stage2, 140 lbf ft (190N m) 19.3 kgf m

Stage3, 160 lbf ft (217N m) 22.0 kgf m

NOTE: Bolts to be lubricated prior to assembly, and should be tightened to torque specification, with the engine cold.

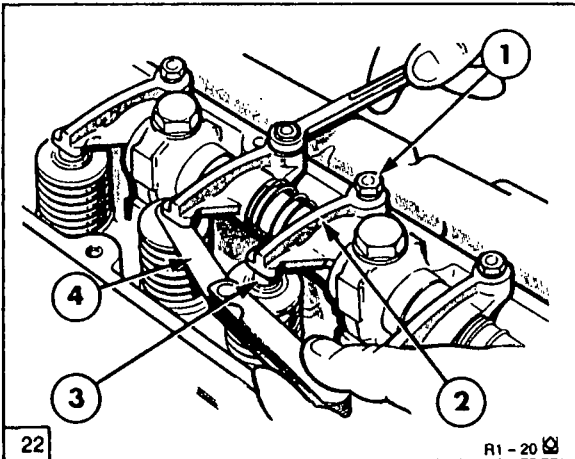

22

R1-20

Setting Valve Lash

- | | |
|-------------------|-----------------|
| 1. Adjuster Screw | 3. Valve Stem |
| 2. Rocker Arm | 4. Feeler Gauge |
3. Adjust valve lash setting with each piston in turn at Top Dead Centre and rockers free to move, Figure 22.

Intake Valve Lash:
0.014–0.018 in (0.36–0.46mm).

Exhaust Valve Lash:
0.017–0.021 in (0.43–0.53mm).

NOTE: Valve lash is to be set only when the engine is cold.

4. Install the injectors with new seat washers, cork seals and torque to 17 lbf ft (23N m) 2.3 kgf m, Figure 6.
5. Install the injector lines and leak off pipes with new washers and torque the leak off banjo bolts to 8 lbf ft (10N m) 1.1 kgf m.

NOTE: Hold the leak off plastic tubing when tightening to prevent the pipes pivoting during torque up.

6. Exhaust manifold bolts are to be refitted and tightened to a torque of 28 lbf ft (38N m) 3.8 kgf m.
7. Intake manifold bolts are to be refitted and tightened to a torque of 28 lbf ft (38N m) 3.8 kgf m.

FRONT COVER AND TIMING GEAR REMOVAL

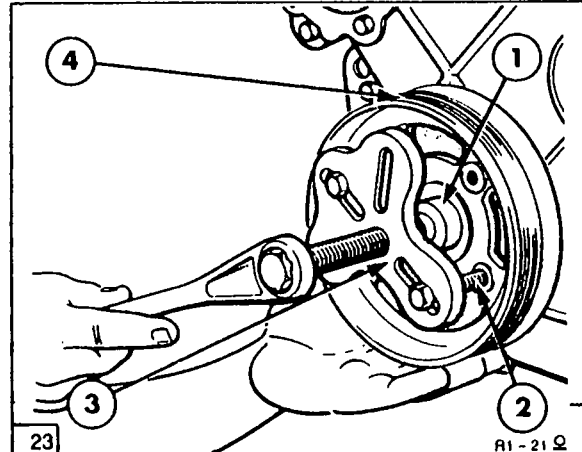

23

R1-21

Crankshaft Pulley Removal

- | | |
|--------------------|----------------------|
| 1. Shaft Protector | 3. Puller |
| 2. Bolt | 4. Crankshaft Pulley |
1. Remove the fan belt and tensioner and withdraw the bolt and washer from the crankshaft pulley.
 2. Using puller No 518 or FT 9539 and shaft protector No 625-A or 9212, remove pulley, spacer and 'O' ring from the shaft, Figure 23.
 3. Disconnect the hydraulic auxiliary pump tubes where fitted, draining the oil into a suitable container and plug all ports to prevent dirt ingress.
 4. Drain the engine oil and remove the oil pan.

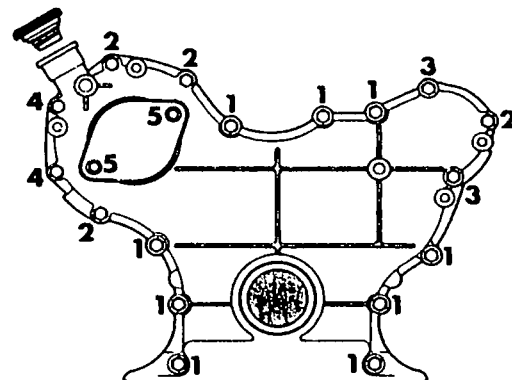

24

R1-21A

Front Cover Retaining Bolt Sequence

5. Withdraw the retaining bolts, and remove the front cover and gasket, Figure 24.

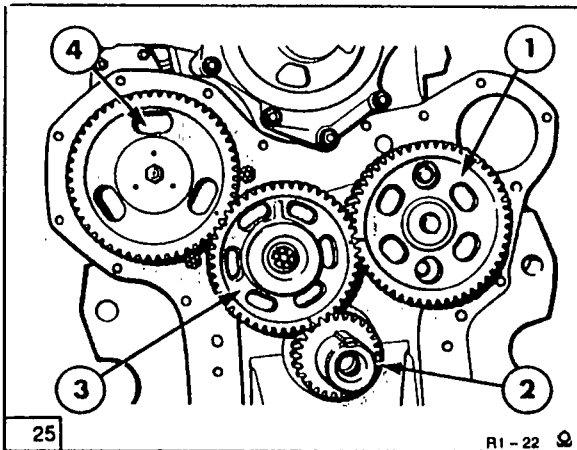

25

R1-22

Timing Gears

- | | |
|------------------------|------------------------------|
| 1. Camshaft Gear | 4. Injection Pump Drive Gear |
| 2. Crankshaft Gear | |
| 3. Camshaft Idler Gear | |

NOTE: The crankshaft timing gear No. 2, Figure 25, should not be removed. The gear is heat shrunk on to the crankshaft and aligned to the crankshaft No.1 pin to 0.004 in (0.10mm). If the gear is damaged a new crankshaft is required.

6. Before removing the timing gears, Figure 25, use a dial indicator or feeler gauge, Figure 26, to measure the backlash between each set of gears.

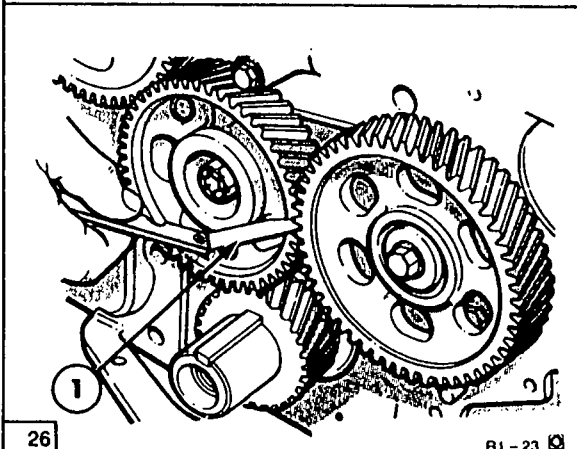

26

R1-23

Timing Gear Backlash

1. Feeler Gauge
7. Rotate the gears and check the backlash using a feeler gauge or dial indicator at four equal points on the gears. Renew if the backlash exceeds the following, Figure 26:-

Backlash to crankshaft gear:
0.006–0.018 in (0.15–0.46mm)

Backlash to camshaft gear:
0.006–0.018 in (0.15–0.46mm)

Backlash to fuel injection pump gear:
0.004–0.021 in (0.10–0.53mm)

CAMSHAFT DRIVE GEAR

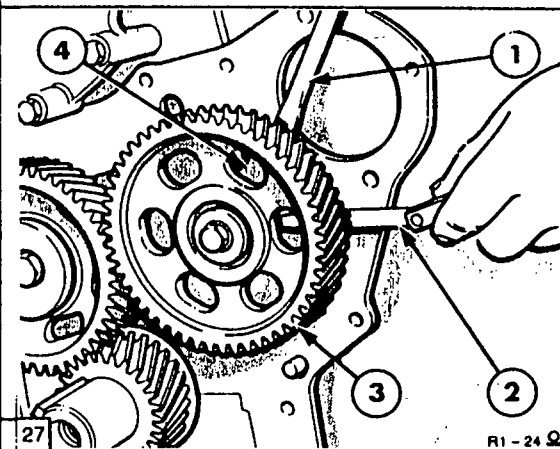

27

R1-24

Camshaft End Play Measurement

- | | |
|-----------------|------------------|
| 1. Lever | 3. Camshaft Gear |
| 2. Feeler Gauge | 4. Thrust Plate |
1. Pry the camshaft gear using a lever away from thrust plate. Using a dial indicator or feeler gauge, check the clearance to 0.002–0.007 in (0.076–0.35mm). If outside of limits fit a new camshaft thrust plate, Figure 27.
 2. Remove the camshaft idler gear retaining bolt, gear and adaptor from the block, then remove the camshaft gear bolt and disassemble.
 3. Remove retaining nut and washer from the fuel pump and remove the gear from the shaft using a puller.

Inspection and repair of gears

1. Wash the gears using a suitable solvent and examine gear teeth for wear, burrs or scratches. Minor marks can be removed using a fine abrasive, thoroughly clean before re-assembly.
2. Ensure the camshaft idler gear adaptor is free from obstruction and bushing is not damaged. Camshaft key and key-way should be checked for damage and repaired as required.

Installation

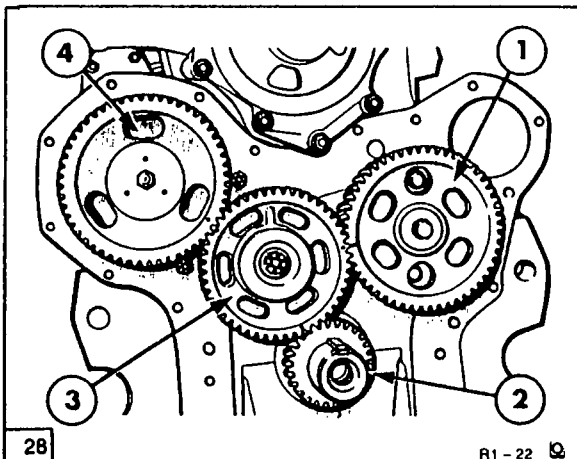

28

R1-22

Alignment of Timing Gears

1. Camshaft Gear
 2. Crankshaft Gear
 3. Camshaft Idler Gear
 4. Injection Pump Drive Gear
1. Position piston No.1 at Top Dead Centre, install the spacer, key and camshaft gear and tighten to 51 lbf ft (69N m) 7.0 kgf m, Figure 28.
 2. Install the camshaft idler gear to the block, align timing marks and torque to 175 lbf ft (237N m) 24kgf m, Figure 28.

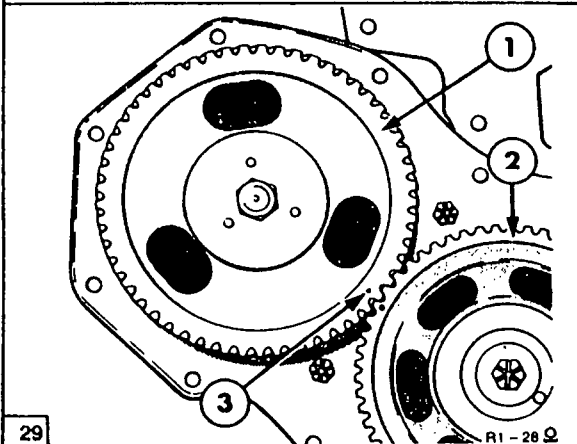

29

R1-28

DPS Pump Gear to Camshaft Drive Gear

1. Pump Drive Gear
 2. Camshaft Idler
 3. Timing Mark
3. With piston No.1 at Top Dead Centre, assemble fuel injection pump with a new seal and align mark on pump flange to 0° timing mark on the front plate. Torque bolts to 18 lbf ft (22Nm) 2.2 kgf m. Install pump gear with timing marks aligned to the idler gear, and torque to 58 lbf ft (78N m) 7.8 kgf m, Figure 29.

NOTE: Fuel pump (injection) timing is set at 10° before Top Dead Centre, when the piston face to cylinder block height is:-
0.043 in (1.1mm) for 4.4 in (112mm) stroke.
0.050 in (1.3mm) for 5.0 in (127mm) stroke.

4. The front oil seal should be renewed every time the front cover is removed. Drive out the old seal using a punch taking care not to damage the front cover.

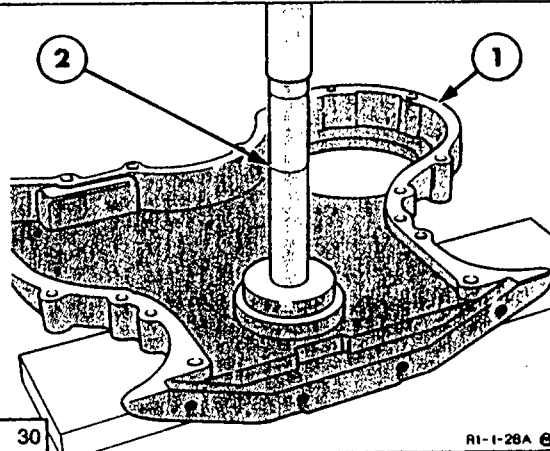

30

R1-1-28A

Front Cover Oil Seal Installation

1. Front Cover
 2. StepTool No 630-16 or T87T-6019-A
5. Coat a new seal in a suitable lubricant and drive the seal into the rear of the front cover using Tool No. 630-16 as in Figure 30. Alternatively, use Tool No. T87T-6019-A and drive the seal into position from the front of the cover.
 6. Position gasket on the front cover plate.
 7. Install the front cover ensuring alignment with dowel pins and tighten the bolts to:-
5/16 in-18 UNC bolts tighten to 13-18 lbf ft (18-24N m) 1.8-2.5 kgf m.
3/8 in-16 UNC bolts tighten to 25-30 lbf ft (34-41N m) 3.4-4.1 kgf m.
 8. Lubricate the crankshaft, fit a new 'O' ring and slide the pulley spacer over the key. Place pulley onto the crankshaft and push home, tightening the securing bolt to 210 lbf ft (284N m) 29kgf m.
 9. Apply sealer D, or J to the front and rear housing joints, fitting a new gasket to the oil pan, and torque the bolts to 28 lbf ft (38N m) 3.9 kgf m.
 10. Refill the fluid levels to the correct specification and quantities as defined.

OIL PAN REMOVAL

WARNING: Due to the weight of the oil pan it is recommended that a hydraulic jack is used to support and lower the oil pan to the ground.

1. Drain engine oil through oil pan plug and remove oil level indicator.
2. Remove oil pan bolts including those through transmission front support and lower to ground.

Inspection and repair

1. Clean gasket material from sump face, clean sump in a suitable solvent, inspect sump for cracks damaged threads or damaged sump face.

Installation

1. Installation is the reverse of removal but with the following requirements:-
2. Ensure block face is clean and free of gasket material. Install a new gasket to the front cover and oil pan. Ensure sealer is applied to the front plate and rear oil seal return joints.
3. Position the oil pan and install a bolt at each corner finger tight to hold in position, install remaining bolts and torque to 28 lbf ft (38N m) 3.9 kgf m.

CONNECTING RODS, BEARINGS, PISTONS AND RINGS, REMOVAL

NOTE: The connecting rods and pistons can be removed with the engine installed after removal of the cylinder head and oil pan sump.

1. With cylinder head removed, clean off any ridge from the top of the cylinder bores with a ridge remover to enable removal of the pistons. This is essential if old pistons are to be re-used as failure to do so could result in ring land damage.

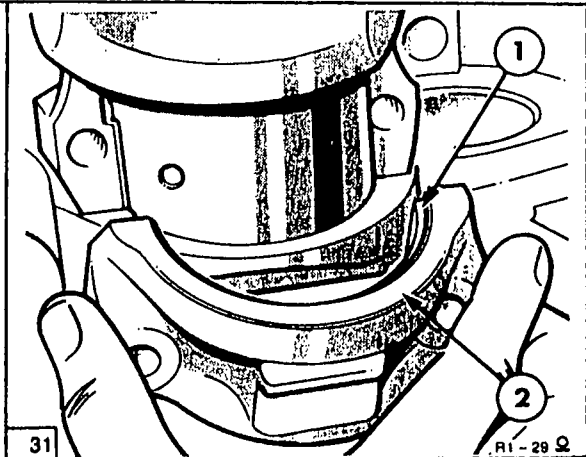
**Connecting Rod End Cap Removal**

1. Bearing Liner 2. End Cap
2. With the piston at the bottom of the stroke remove the end cap bolts, cap and liner. Using the handle end of a hammer push the piston assembly out through the top of the block and remove the liner from the connecting rod, Figure 31.
3. Turn the crankshaft again and repeat the process for the remaining pistons.

NOTE: Bearing caps and liners must be kept with their respective connecting rods.

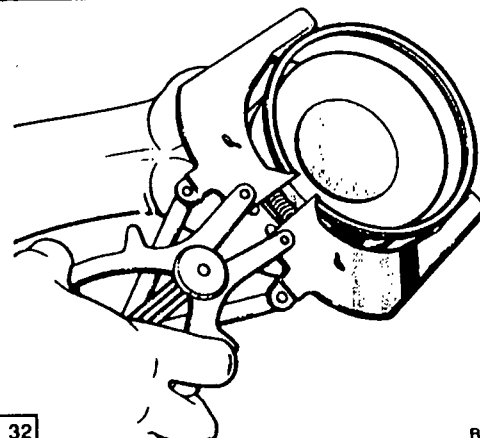
**Piston Ring Removal**

4. Remove piston pin snap rings from each side of piston and remove pin. Using an expander, remove the piston rings, Figure 32.

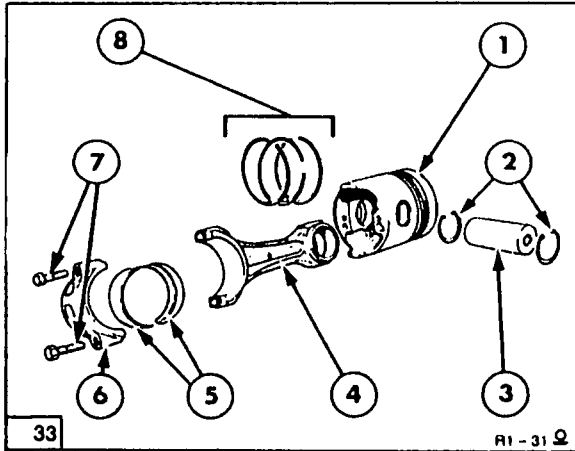

33

RI-31 Q

Piston Assembly Disassembled

- | | |
|-------------------|--------------------|
| 1. Piston | 5. Bearing Liners |
| 2. Pin Retainers | 6. Bearing Cap |
| 3. Piston Pin | 7. Retaining Bolts |
| 4. Connecting Rod | 8. Piston Rings |

5. Ensure each piston and rod assembly remains matched together for re-assembly, Figure 33, into the cylinder block.

Inspection and Repair

1. Clean the piston and connecting rod assembly in a suitable solvent and inspect for damage to ring lands, skirts, or pin bosses.

2. Check connecting rod components for damage and place in an alignment fixture to check for distortion. Ensure that any distortion, is within specification as follows:-

Maximum Twist 0.012 in (0.30mm).

Maximum Bend 0.004 in (0.10mm).

3. Check piston pin bushing for damage or wear in the following manner.

Measure the outside diameter of the piston pin, and inside diameter of the connecting rod bushing to the following,

Piston Pin Outside Diameter

Naturally Aspirated:

1.4998–1.500 in (38.095–38.100mm).

Turbocharged:

1.6248–1.625 in (41.270–41.275mm).

Connecting Rod Bush Internal Diameter

Naturally Aspirated:

1.5005–1.5008 in (38.113–38.120mm).

Turbocharged:

1.6255–1.6258 in (41.288–41.295mm)

CONNECTING ROD BUSH

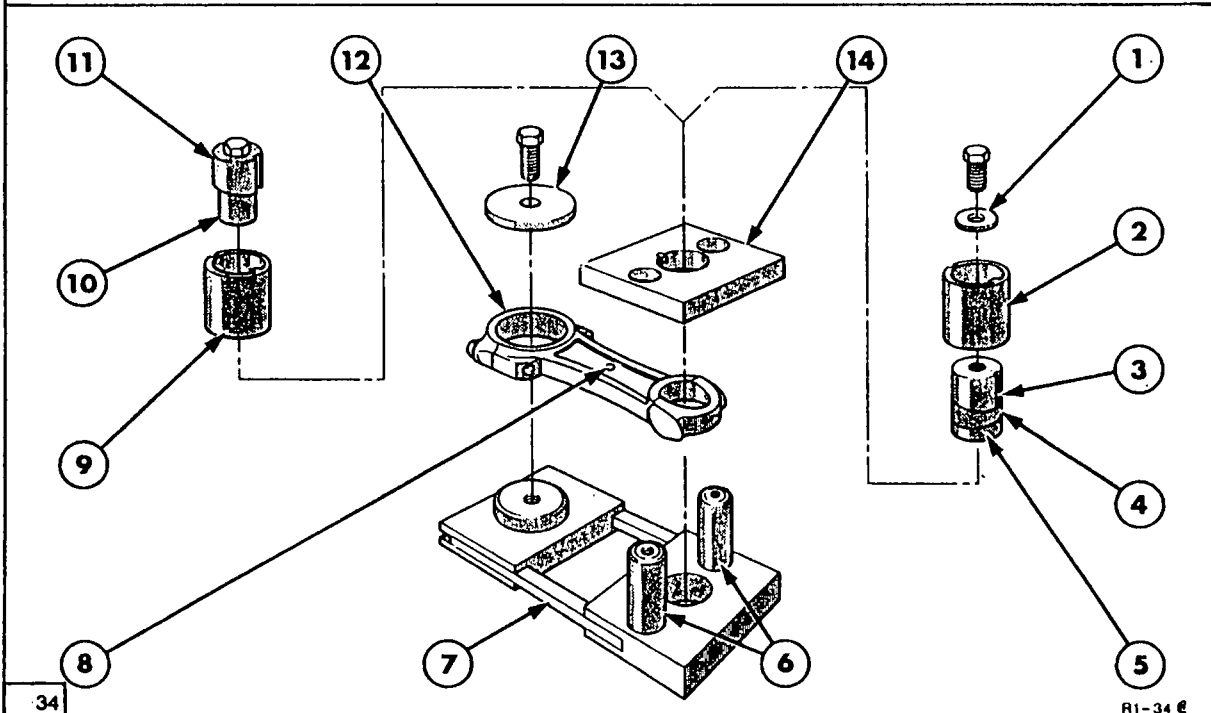

34

RI-34 E

Removal

1. Washer
2. Collar
3. Installation Insert 1
4. Bush
5. Installation Insert 2

Connecting Rod Bush Installation

6. Pins
7. Fixture
8. Connecting Rod Facing up
9. Remover Insert 1
10. Remover Insert 2

Installation

11. Remover Insert 3
12. Connecting Rod Location
13. Washer
14. Location Plate

1. If not to specification use Tool No. FNH 00053 and press out the old bush using the removal fixture as shown in Figure 34. Press fit a new bush through the fixture using the installation detail and into the connecting rod as shown in Figure 34. After fitting a new bush ensure all sharp edges and burrs are removed.

NOTE: **A**, Ensure the split in the small end bush is at right angles to centre line of connecting rod. **B**, Connecting rods should only be changed as matched sets.

2. Where special tooling is not available for the removal or fitment of the connecting rod bush a standard bush can be fitted, Figure 35, in the following manner:
3. Place the connecting rod securely in a bench press. Manufacture from suitable bar stock, a press tool with the end face ground at an angle to suit the connecting rod bush side face. Position the tool on the bush and gently drive the bush from its position. It is recommended a guide is manufactured to assist alignment of the bar stock during this operation.

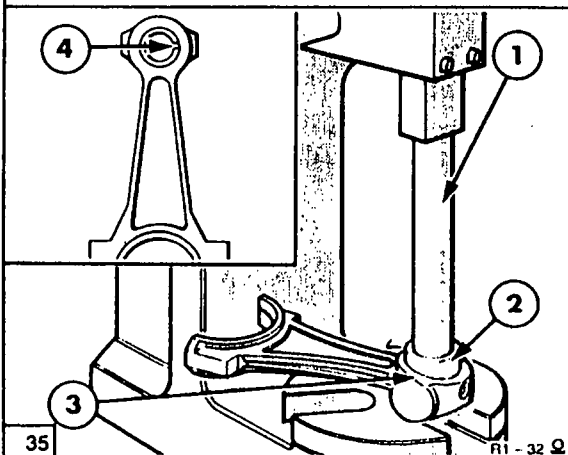

Connecting Rod Bush Fitment

1. Press Tool
2. Bush
3. Machined Side
4. Bush Slot Alignment

4. A new bush can then be fitted in a similar manner by using a suitable piece of bar stock with an end face machined flat to suit the standard parallel bush. Use a guide as described and gently drive in the new bush into the connecting rod.

5. After installation grind the side faces of the new bush to match the side faces of the connecting rod. Ensure all sharp edges are removed and loose chippings are cleaned from the connecting rod before re-assembly into the engine.

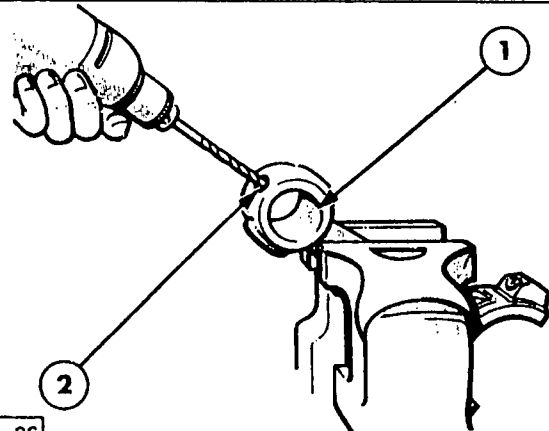

Drilling of Connecting Rod

1. Connecting Rod
2. Drill
6. With a new bush fitted, drill a hole through the top of the connecting rod using a 0.187 in (4.6mm) and drill through the existing oil hole, Figure 36.
7. Use an expanding reamer to obtain correct bushing to piston pin clearance referring to specification section. Remove burrs and chippings before refitting.

CYLINDER BLOCK OVERHAUL

1. Cylinder block plugs and senders require changing if leaking or rusty and must be replaced. Clean the old sealant off the block and fit new plugs with sealer, this applies to both the 4 and 6 cylinder engine range.

Figure 37 refers to the front and left hand side of the cylinder block.

NOTE: New part mating faces and threads should be coated in sealant, refer to "Specifications". Assemble in the following manner:-

- Plug (1) torque to 6-10 lbf ft (8-14N m) 0.8-1.3 kgf m. Use sealant C.
- Switch (2) torque 18-25 lbf ft (24-34N m) 2.4-3.4 kgf m. Use sealant E.
- Plug(3) torque to 50-70 lbf ft (68-95N m) 6.9-9.6 kgf m. Use sealant F.
- Plug (4) drive in to block.
- Plug (5) torque to 18-25 lbf ft (24-34N m). 2.4-3.4 kgf m. Use sealant E.

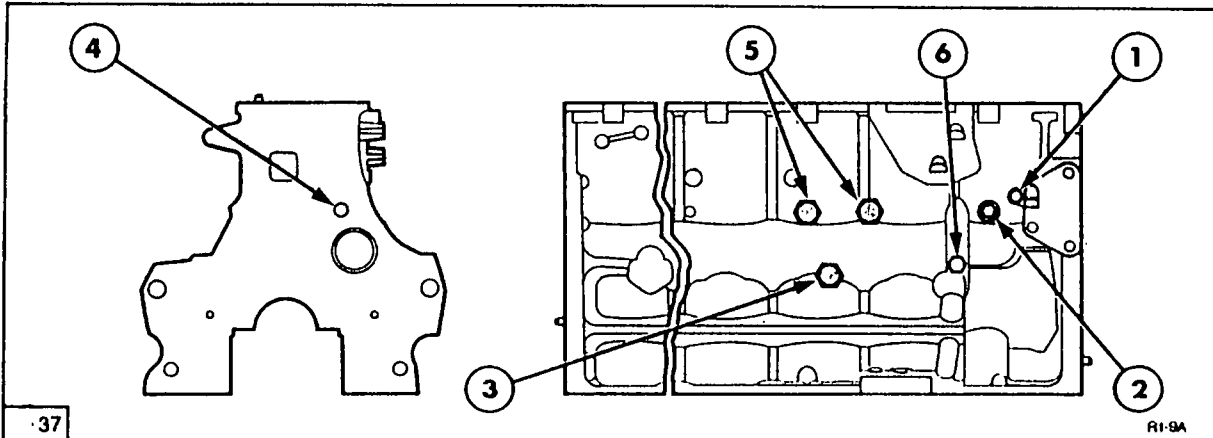

37

R1-9A

Cylinder Block Core Plug and Sensor Ports, Front and Left Hand Side

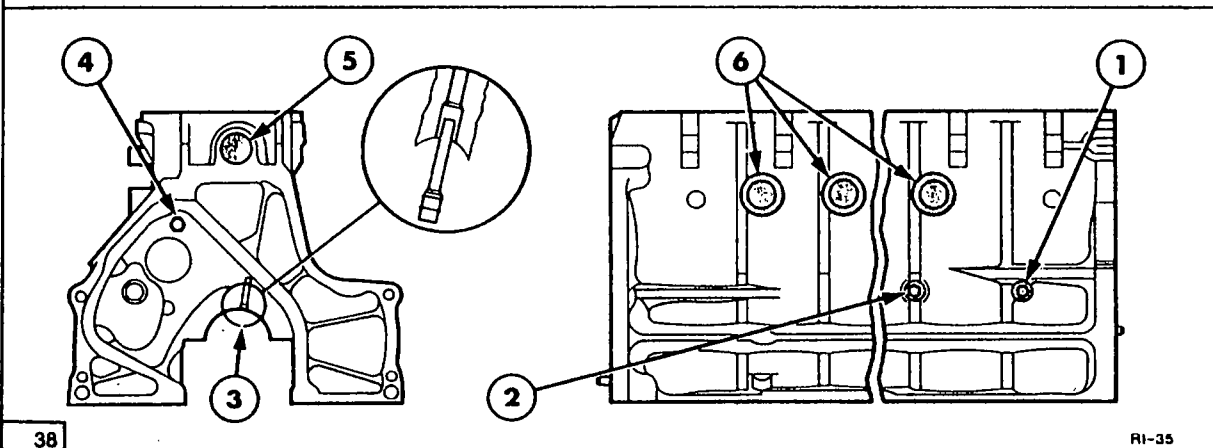

38

R1-35

Cylinder Block Core Plug and Sensor Ports, Rear and Right Hand Side

Plug (6) torque to 20–35 lbf ft (27–47N m)
2.7–4.8 kgf m. Use sealant, E.

2. Figure 38 refers to the rear and right hand side of the block.

Plug (1) torque to 18–25 lbf ft (24–34N m).
2.4–3.4 kgf m. Use sealant E.

Plug (2) torque to 6–10 lbf ft (8–14N m).
0.8–1.4 kgf m. Use sealant E.

Oil Jets (3) replace with new if damaged, apply engine oil only on re-assembly "Do not use sealant".

Plug (4) torque to 40–60 lbf ft (54–81N m)
5.5–8.2 kgf m.

Plug (5) drive into block.
Use sealant G.

Plug (6) drive into block.
Use sealant G.

CYLINDER BORE

1. Check the cylinder bore for scuffing or rings around the ring travel area. Irregularities can be felt by running a finger over the surface. To check out-of-roundness, wear, or taper, use a telescopic gauge, Figure 39.

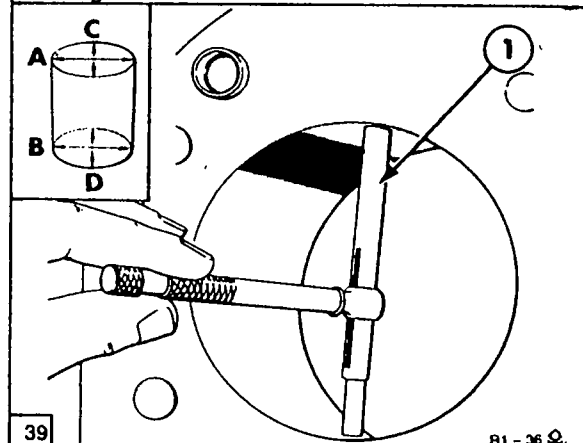

39

R1-36

Break the sharp edge at the bottom of the sleeve prior to honing.

9. Hone the cylinder bore to:—
Grade A, 4.4007–4.4015 in.
Grade B, 4.4015–4.4023 in.

NOTE: Surface finish to be an average of 20 to 30 Microns, cross hatched at 35°–55°.

Maximum Taper:
0.001 in (0.025mm) through to bottom of the bore.

Maximum Ovality:
0.0015 in (0.038mm)

Re-Assembly

NOTE: Pistons that are replaced must be of the same type that were removed and have the same identification letters and numbers as embossed on the underside of the old piston.

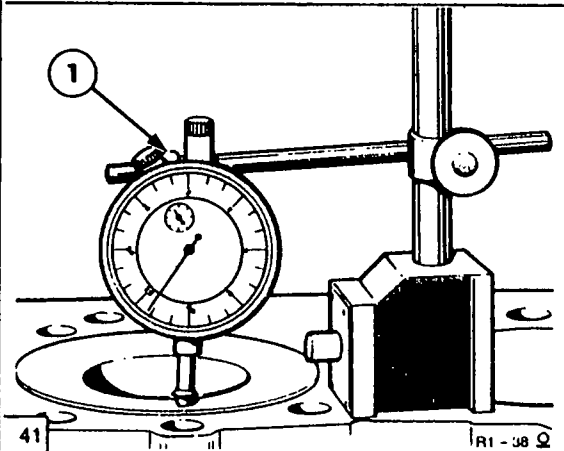

Piston to Cylinder Block Height

1. Dial Indicator

1. Upon re-assembly with the piston at Top Dead Centre, ensure the piston to block height is correct using a dial indicator, Figure 41.

Naturally Aspirated:
0.011–0.023 in (0.28–0.58mm)

Turbocharged:
00.00–0.012 in (0–0.3mm)

2. Check the piston to bore clearance in the following manner.

A, Measure the cylinder bore diameter cross-wise, then measure piston diameter at right angles to the piston pin.

B, Subtract piston diameter from the bore diameter and the resultant figures should be:—

0.0065–0.0055 in (0.165–0.140mm)
Naturally Aspirated,
0.0065–0.0075 in (0.165–0.190mm)
Turbocharged engines.

NOTE: Pistons are available as standard and oversize, new pistons should always be fitted if the clearance exceeds specification.

C, If clearance is "greater" try a similar new piston, if limit is still exceeded measure remaining cylinder bores and pistons and establish greatest clearance.

Based on the highest figure, re-bore to take the next oversize piston.

D, If the clearance is "less" hone bore to obtain desired clearance.

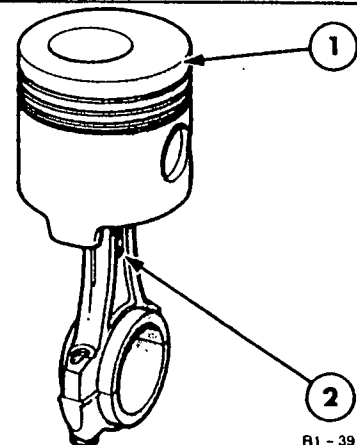

Piston Connecting-Rod Alignment

1. Piston
2. Pip on Rod
3. Lubricate all of the components with engine oil and assemble the connecting rod and piston, with the letter or grade mark on the piston, aligned to the pip on the connecting rod. Install the piston pin and retainers, Figure 42.

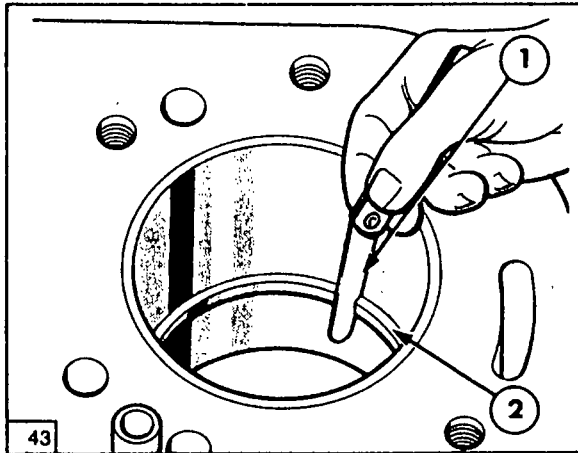

Piston Ring Gap

1. Feeler Gauge 2. Ring

4. Check the piston ring gap width using a feeler gauge, in a vertical position at the top, middle and bottom of the bore, Figure 43.

Top compression ring:
0.015–0.033 in (0.38–0.84mm).

2nd compression ring:
0.026–0.044 in (0.66–1.12mm).

Oil control ring:
0.015–0.033 in (0.38–0.84mm).

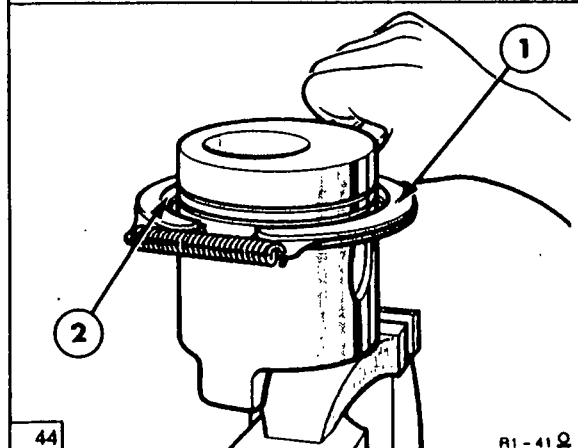

Piston Ring Installation

1. Piston Ring
Expander 2. Piston Ring

5. Ensure the correct expander is used to remove or install rings, Figure 44.

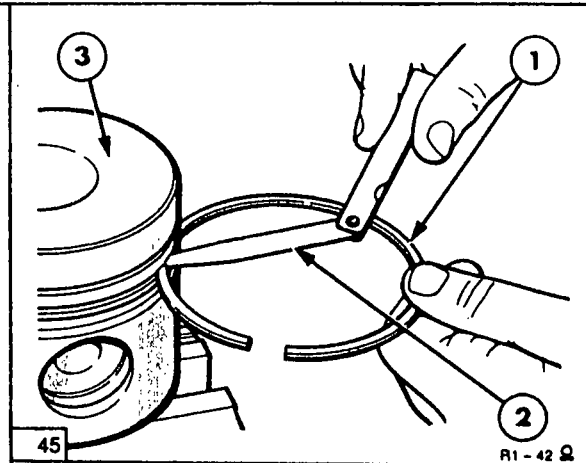

Piston Ring Side Clearance

1. Piston Ring 3. Piston
2. Feeler Gauge

6. Using a new piston ring, check with a feeler gauge the gap between the ring and groove, Figure 45.

Top compression ring:
0.0044–0.0061 in (0.112–0.155mm).

2nd compression ring:
0.0039–0.0056 in (0.099–0.142mm).

Oil control ring:
0.0024–0.0041 in (0.061–0.104mm).

7. Install the piston rings, Figure 46, but note the following:

NOTE: Before installing new pistons and rings into a used cylinder bore, remove the high polish from the cylinder walls by honing as previously described.

8. Install top and second compression rings with the word top towards the top of the piston. Ensure the ring gaps are staggered a minimum of 40° from each other on the diameter and with no gap on the thrust side of the piston.

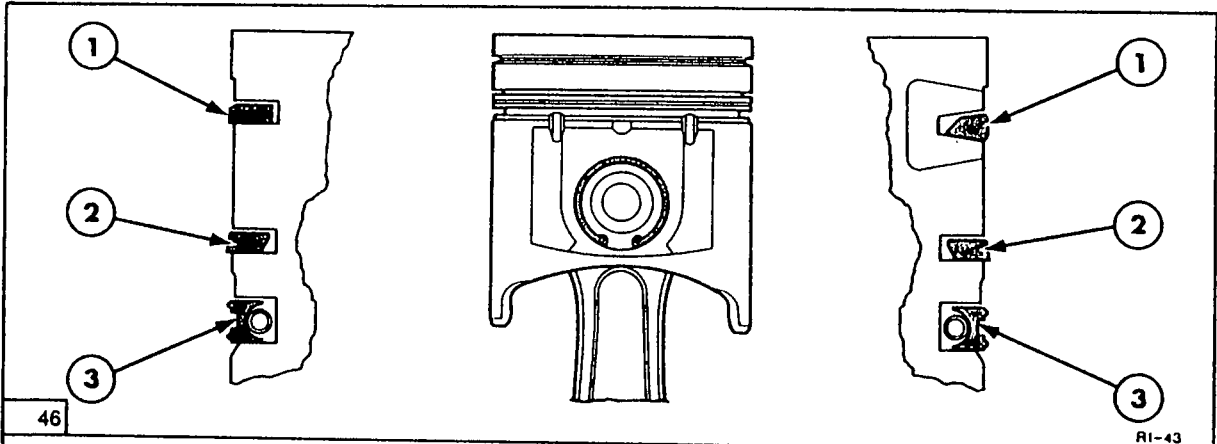

46

RI-43

Naturally Aspirated

Piston Ring Assembly

Turbocharged

1. 1st Compression Ring
2. 2nd Compression Ring
3. Oil Control Ring

1. 1st Compression Ring
2. 2nd Compression Ring
3. Oil Control Ring

**PISTON ASSEMBLY
INSTALLATION
INTO BLOCK**

1. Select the correct bearing liners as in the following crankshaft section and install in the rod and cap, ensure the liner tang locates in the slots of the rod and cap.

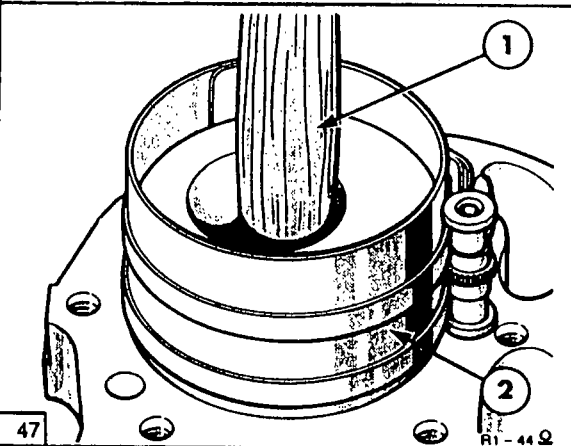

47

RI-44 Ω

Piston and Connecting Rod Installation

1. Soft Drive 2. Ring Compressor
2. Turn the crankshaft, to position No.1 crankpin at the bottom of the stroke and lubricate all parts with new engine oil. Using a ring compressor and a soft drive, slide pistons into bores, ensuring grade letter on pistons is towards the front of the engine, Figure 47.
3. Ensure the connecting rod bearing liner, seats on the crankpin with the bearing cap fitted to the connecting rod as a matched assembly. Fit new bolts lubricated with oil and tighten to a torque value of 110 lbf ft (149N m) 15 Kgf m.

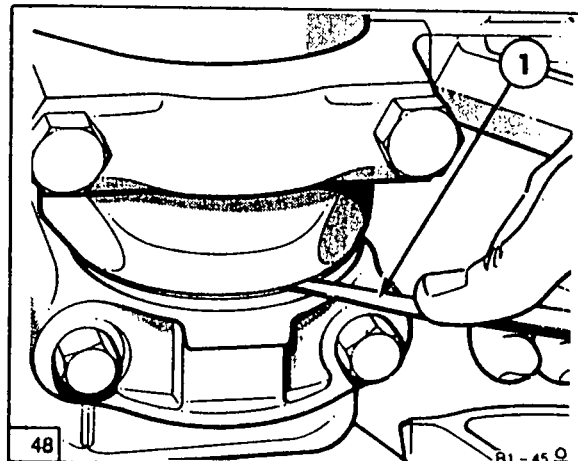

48

RI-45 Ω

Connecting Rod Bearing Side Clearance

1. Feeler Gauges
4. Using feeler gauges, check the side clearance of each connecting rod to crankshaft, Figure 48: 0.005–0.013 in (0.13–0.33mm) and continue for remaining assemblies.
5. Refit the oil pump tube/screen, balancer and oil pan as previously described, refill engine oil and coolant and run the engine checking for leaks.

NOTE: Replaceable bearing liners are installed in production to ensure correct crankshaft journal to bearing clearance is maintained in service.

Balancer

(ENGINE 7450 I..SI..)

Inspection and repair

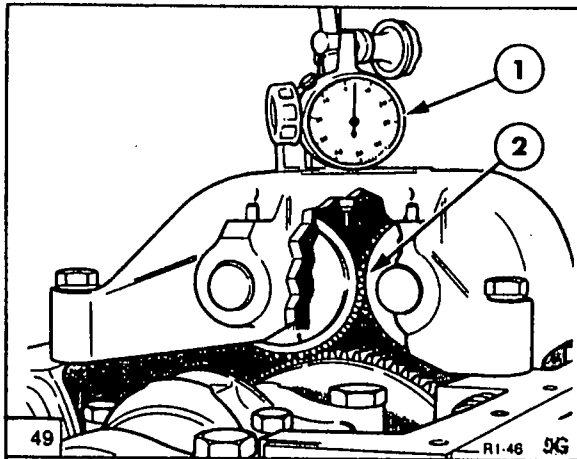

Balancer Gear Backlash

1. Dial Indicator 2. Backlash Check

- Remove the oil pan to expose the balancer and using a dial indicator gauge, check backlash between crankshaft gear and balancer drive gear, Figure 49. Position the dial plunger to the face of one of the drive gear teeth, then rock the gear to measure backlash. Readings should be taken at 90° intervals around the drive gear to 0.002–0.012 in (0.05–0.30mm). If the specification is exceeded, install new balancer gears.

Disassembly

- Extract the roll pins securing the shafts to the housing and disassemble, Figure 50.

- Measure the outside diameter of shafts and the inside diameter of the gear bushings and establish if clearance is to specification. If exceeded, replace shaft and / or gear assembly: 0.0002–0.008 in (0.005–0.020mm).
- Examine shafts and balancer gear teeth for wear and damage and replace as necessary. Ensure lubrication holes in the shafts are free from obstruction upon re-assembly.

For crankshaft balancer gear repair and assembly, refer to the crankshaft section.

Re-Assembly

- Position balancer gears and thrust washers in the housing, with timing marks aligned and facing the roll pin side of the balancer. Install shafts from the opposite side and secure with roll pins.
- Using a feeler gauge measure end float of assembled gears is to the specification: 0.008–0.020 in (0.20–0.51mm).
- Position a dial indicator gauge to the tooth of one gear and hold the other firmly. Rocking the free gear, measure backlash at 90° intervals around the gears to 0.002–0.010 in (0.05–0.25mm).

Installation

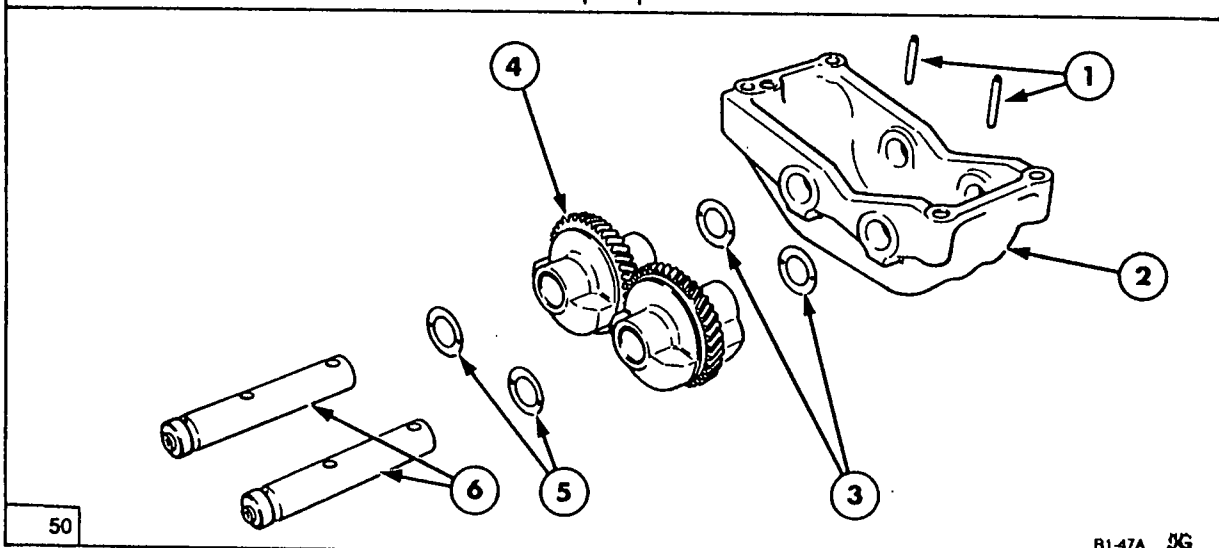

Balancer Gears

1. Roll Pin 3. Thrust Washers 5. Thrust Washers
2. Housing 4. Driven Gears 6. Shafts

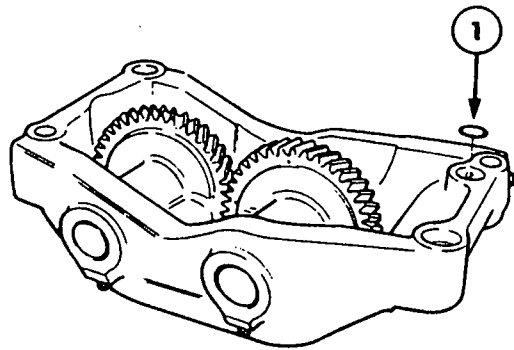

51

R1-48 5G

Balancer Gear Assembly

1. 'O' Ring
1. Clean all the mating surfaces and install a new 'o' ring in the lubrication port, Figure 51.

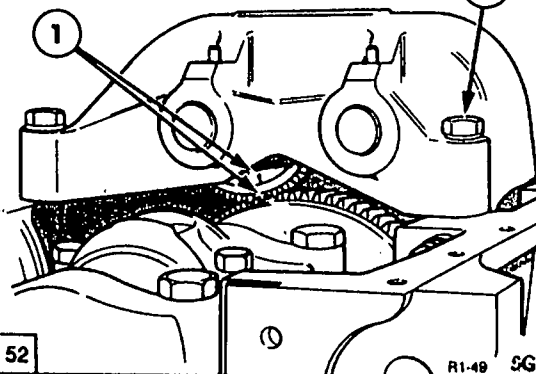

52

R1-49 5G

Timing of Balancer to Crankshaft

1. Gear Alignment
 2. Attaching Bolts
2. Rotate crankshaft until timing mark on crankshaft gear aligns with timing mark on balancer drive gear, Figure 52. Position balancer on dowels, install the bolts and torque to 80–90 lbf ft (108–120N m) 11–12.4 kgf m.
 3. Recheck the gear backlash between crankshaft and balancer gear, as previously described and replace the oil pan.

MAIN BEARING REMOVAL

1. Remove the oil pan and balancer, to gain access to the crankshaft. Remove the main bearing cap from the journal to be repaired and install only one set at a time. Leave the remainder securely in place.

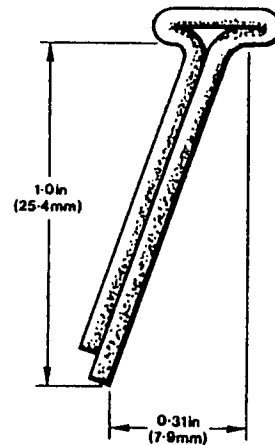

53

R1-50 Q

Bearing Liner Removal Tool

NOTE: A liner removal tool can be fabricated from a 1 in (25mm)x1/8 in split pin, flatten and bend the head to conform to angle of oil passage in the crankshaft.

2. Install the bearing liner removal tool Figure 53, in the crankshaft journal oil passage. Turn the crankshaft counter clockwise until the tool forces the bearing out of the cylinder block.

Inspection and Repair

1. Thoroughly clean bearing liners, journals and caps and inspect for wear, scores or damage, replace as required.

Installation

1. Coat all parts in new engine oil prior to assembly. Position the bearing cap with locking tang towards the camshaft side of the engine and fit the bolts, tighten evenly to 140–150 lbf ft (190–203N m) 19.3–20.1 kgf m.
2. If a new thrust bearing liner is installed bearing must be aligned as in following crankshaft chapter.

FLYWHEEL REMOVAL

1. To gain access to the flywheel separate the engine to transmission.

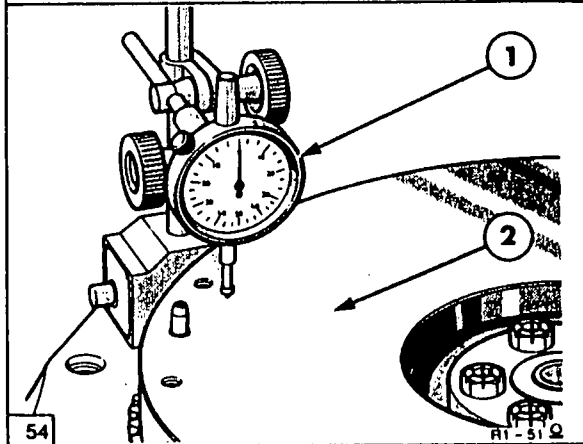

Flywheel Runout

1. Dial Indicator
2. Flywheel

2. Prior to removal and using a dial indicator, rotate the flywheel, Figure 54, and measure to specification 0.005 in (0.127mm) Total Indicator Reading. If not to specification check crankshaft to flywheel seating.

Inspection and Repair

1. Inspect the flywheel ring gear and if damaged renew in the following manner:—

Cut old ring gear free from the flywheel.

Clean the mating surfaces of the new ring gear and flywheel.

2. Use temperature indicating crayons to mark the side face of the ring gear in six equal places, mark with a 204°C (400°F) crayon at a point 0.5 in (13mm) below the root of the teeth and mark with a 212°C (450°) crayon at a point just below root of the teeth.

3. Use an oxy-acetylene torch with a tip size of No.2 maximum and direct the flame against the internal face of the gear.
4. Quickly place the hot gear on the flywheel, with flat face against the shoulder on the flywheel. The gear to flywheel runout should be checked using a dial indicator and should not exceed a Total Indicator Reading of 0.025 in (0.63mm).

Installation

1. Clean the crankshaft rear flange and mating surface of the flywheel and install the flywheel, torque the bolts to:
145 lbf ft (197N m) 20 kgf m.

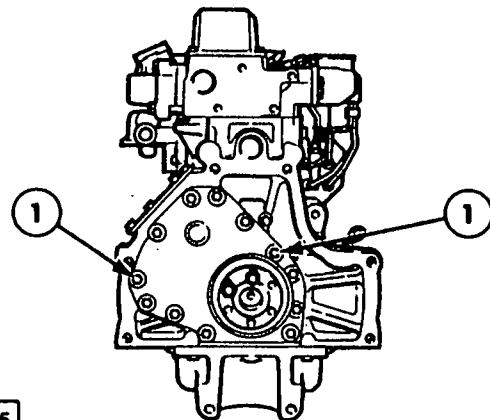
REAR COVER PLATE REMOVAL

Rear Cover Plate Removal

1. Retaining Bolts
1. To gain access to the engine oil pump, camshaft gear or end of crankshaft, remove the oil pan as previously described and the rear cover, Figure 55, in the following manner:
2. With rear of engine exposed loosen and remove the 12 attaching bolts and gently pry off cover plate.

3. Clean off all sealer, remove crankshaft oil seal and check for damage or distortion around the sealing faces.

Installation

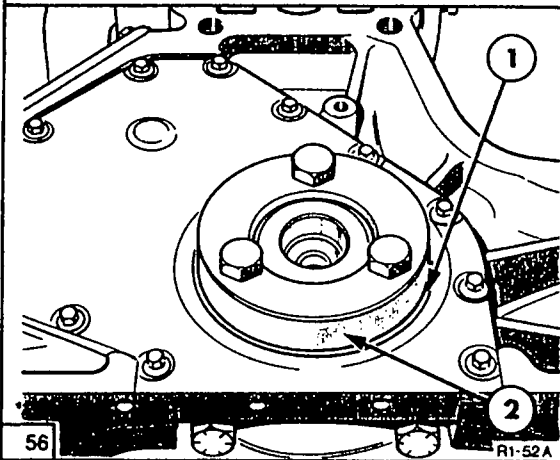

Rear Crankshaft Oil Seal Installation

1. Rear Oil Seal
2. Tool No. FNH 01301

1. Apply a liberal coating of new engine oil on a new oil seal and position the rear seal over the end of the crankshaft. Locate Tool No. FNH 01301 on the end of the crankshaft using the three attaching bolts. Tighten evenly and squarely, until the seal is fully seated, Figure 56.

As an alternative the rear crankshaft oil seal can be installed using the following installation tool.

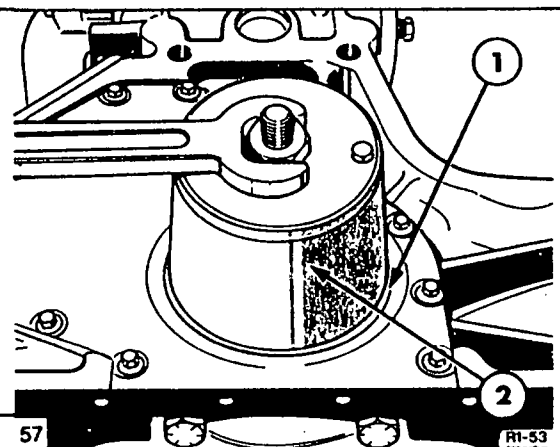

Rear Crankshaft Oil Seal Installation

1. Rear Oil Seal
2. Tool No. FT 6212

1. Apply a liberal coating of clean engine oil to the rear seal retainer, seal and journal.

A new seal should be mounted on the crankshaft, then bolt Tool No. FT 6212 to crankshaft end and install the new seal squarely, Figure 57.

2. Secure centre stock of tool to crankshaft flange with two screws. Assemble cylinder end plate to centre stock and secure with nut and washer as in Figure 57. Tighten the nut until outer diameter of tool abuts retainer. Tool must not be over tightened as stress and distortion could be imposed on the retainer.
3. Remove the tool after assembly and check the crankshaft seal run out as shown in Figure 59.

NOTE: The first seal replacement should be pushed into retainer with plain end of tool and subsequent seals with stepped end of tool which will reposition seal 0.060 in (1.52mm) further in.

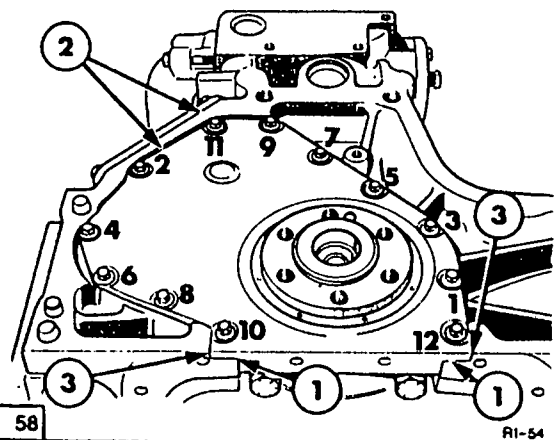

Rear Cover Plate

1. Sealer Application
2. Retaining Bolts
3. Plate Alignment
4. Ensure rear of block face is clean and free of old sealer, install a new gasket and apply sealer D or J to faces (1), Figure 58. With the plate in the recess, install and tighten the twelve bolts in sequence to 12-17 lbf ft (16-23N m) 1.6-2.3 kgf m, Figure 58.
5. Ensure edges of the retainer and seal assembly are even with edges of block within 0.003 in (0.08mm), Figure 58. If not to specification, loosen and re-align retainer in the recess and repeat the installation procedure.

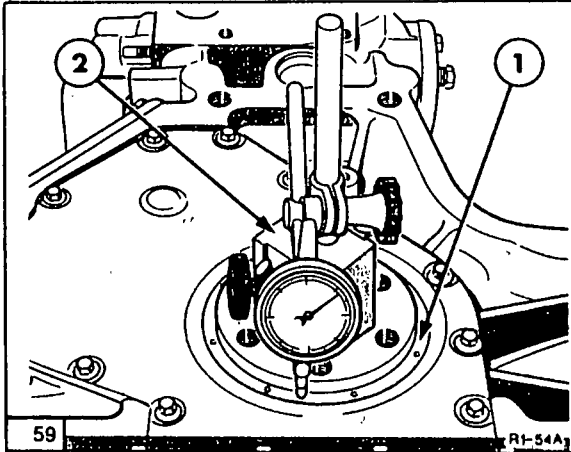

Measuring Crankshaft Seal Runout

1. Crankshaft Seal 2. Dial Indicator
6. With new crankshaft seal installed, place a dial indicator on the end of the crankshaft and ensure seal runout is within 0.020 in (0.51mm) Total Indicator Reading, Figure 59.

OIL PUMP REMOVAL

NOTE: The oil pump can only be removed with the engine split from the transmission and the flywheel, back plate, engine oil pan and oil pump tube removed.

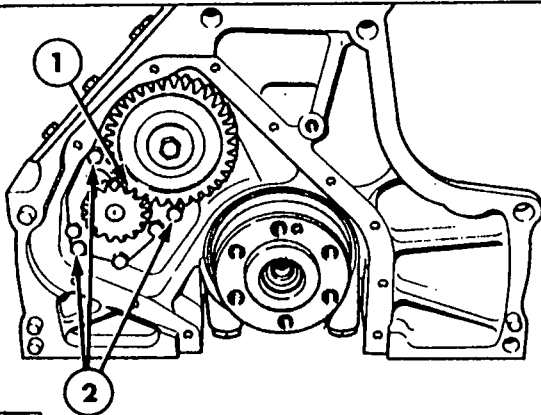

Engine Oil Pump

1. Gear Backlash Measurement
2. Pump to Block Mounting Bolts
1. Prior to pump removal check pump gear to camshaft gear backlash does not exceed, 0.016–0.022 in (0.40–0.56mm), Figure 60.
2. Loosen and remove the camshaft gear to expose the oil pump, detach the 3 pump mounting bolts (this is the same for both 4 and 6 cylinder models), and withdraw the pump from the block, Figure 60.

Disassembly

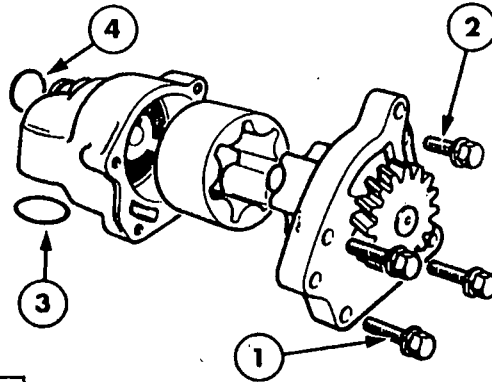

Oil Pump Disassembly

1. Retaining Bolts
2. Retaining Bolts 6Cyl
3. 'O' Ring Intake Port
4. 'O' Ring Outlet Port
1. Loosen and remove the pump face plate to body bolts. There are 3 off in the 4cylinder pump face and 4 off, in the 6 cylinder pump face. Disassemble the pump and discard the 'O' rings, Figure 61.

Inspection and Repair

1. Wash all parts in a suitable solvent and inspect inside of pump plate and body, for excessive wear or damage. If visually okay check in the following manner.

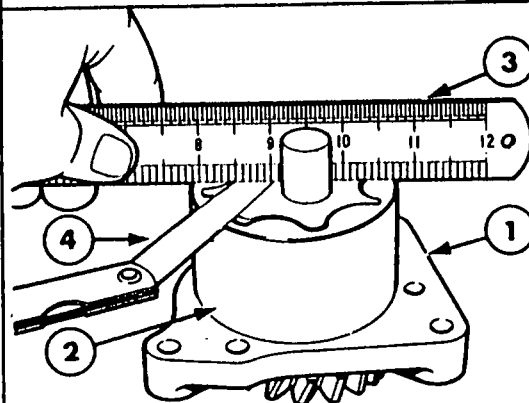

Measuring Oil Pump Rotor

1. Rotor Body 3. Straight Edge
2. Outer Rotor 4. Feeler Gauge
2. Invert pump plate/rotor assembly and place outer rotor over inner rotor. Placing a ruler across top of both, slide a feeler gauge between ruler and inner rotor to 0.001–0.0035 in (0.025–0.089mm), Figure 62.

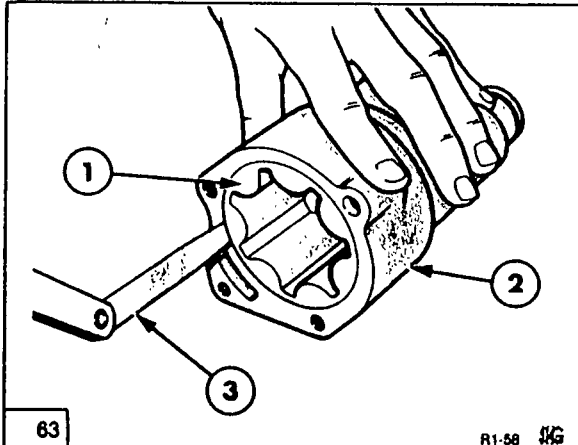

63

R1-58 3G

Measuring Outer Rotor to Pump Body

1. Outer Rotor
2. Pump Body
3. Feeler Gauge

3. Place outer rotor in pump body and check clearance by inserting a feeler gauge between the rotor and body. Check to a max of 0.022 in (0.55mm), Figure 63. If exceeded a new pump is required.

NOTE: If not to specification replace the oil pump, as reduced pump pressure through wear could result in reduced engine life.

Installation

1. Clean and coat parts in new engine oil. Place outer rotor in pump body and ensure free rotation. Insert inner rotor and pump plate assembly into the body and ensure that shaft is fully seated into bushing.
2. Assemble the front plate to the body using 3 or 4 bolts and torque to 17–21 lbf ft (23.0–28.4Nm) 2.3–2.9 kgf m.

NOTE: After tightening ensure the drive gear rotates freely by hand at least 5 revolutions, if not "disassemble" and repeat the exercise.

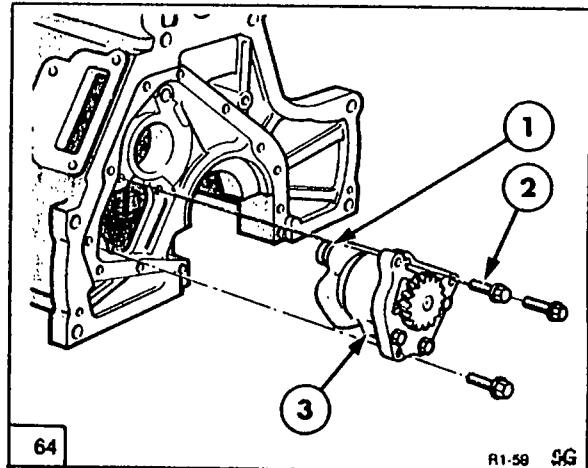

64

R1-58 3G

Assembly of Oil Pump

1. 'O' Ring Output Tube
 2. Retaining Bolts
 3. Oil Pump
3. Fit a new 'O' ring to the output tube, lubricate and insert the pump into the block tightening the bolts, Figure 64 to 17–21 lbf ft (23.0–28.4N m) 2.3–2.9 kgf m

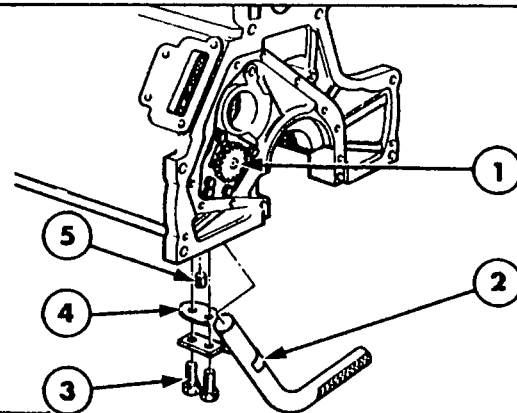

65

R1-58A 3G

Oil Pump Intake Tube

1. Oil Pump
 2. Pump Intake Tube
 3. Gasket
 4. Retaining Bolts
 5. Plug
4. Fit a new 'O' ring, Figure 61, into suction port. Lubricate and insert tube/screen assembly into pump through bottom of engine. Fit a new gasket and torque the attaching bolts, Figure 65, to 20–25 lbf ft (27–34N m) 2.7–3.4 kgf m.

NOTE: Plug item 5, in Figure 65, is factory installed to facilitate machining and should not be removed during the life of the engine.

5. Refit gears as previously described along with the rear plate and flywheel.

OIL FILTER SUPPORT ASSEMBLY

Removal

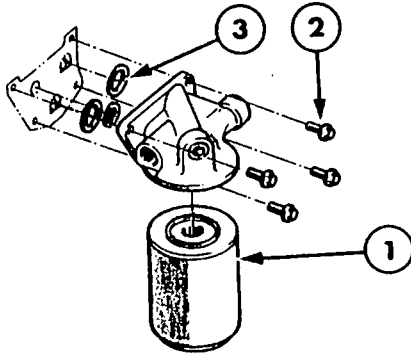

66

R1-60 2G

Oil Filter Assembly

- 1. Oil Filter
- 2. Filter Housing Support Bolts
- 3. 'O' Rings

1. Unscrew and discard the old filter, loosen the 4 attaching bolts and oil connections and remove filter support assembly from the block. Discarding the three 'O' rings, Figure 66.
2. Clean the filter support in a suitable solvent.

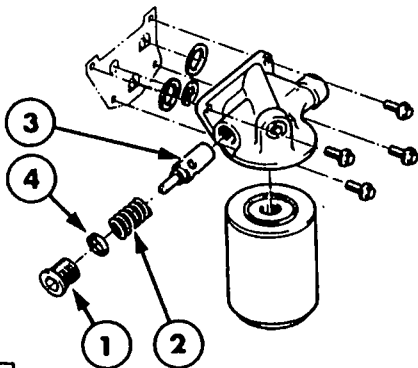

67

R1-61 2G

Oil Filter Relief Valve

- 1. Relief Valve Plug
- 2. Spring
- 3. Valve
- 4. 'O' Ring

3. Remove pressure relief valve plug, removing valve and spring. To ensure correct operation of the pressure relief valve, check spring length:-
Free length = 2.08 in (52.8mm).
Compressed length = 1.46 in (37.0mm) using a weight of 34.3 lbs (15.6 kgs).

4. Clean assembly in a suitable solvent and ensure all ports are free of dirt, Figure 67.
5. Check the parts for damage, wear, and replace as necessary. Failure to do so could result in premature wear to the engine, due to oil bypassing the filter and returning back to the system.

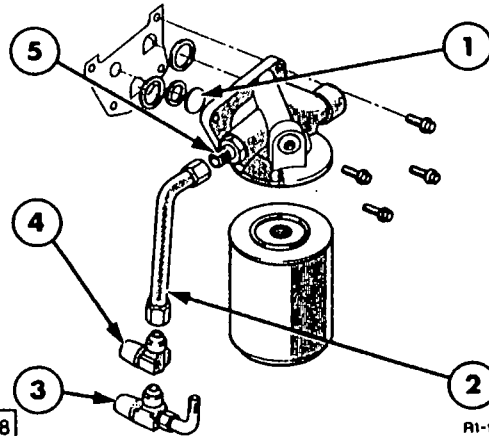

68

R1-91 6

Oil Filter Assembly

- 1. Blanking Disc
- 2. Oil Return Pipe
- 3. Connector with Turbocharger 4 Cylinder
- 4. Connector less Turbocharger 6 Cylinder
- 5. Connector to Filter Head

6. On 6 cylinder vehicles the design varies slightly in that the oil return to block port is blanked off at the filter head. An oil return tube to block is then fitted to the pressure relief valve port, Figure 68.

Installation

1. Lubricate the pressure relief valve, and spring, and insert into housing ensuring free movement. Fit a new 'O' ring to plug (1) Figure 67, or connector (5), Figure 68 and torque to 42 lbf ft (55N m) 5.5 kgf m. Fit tube to connector and torque to 20 lbf ft (27Nm) 2.7 kgf m, Figure 68.

CRANKSHAFT REMOVAL

2. Remove the flywheel, rear cover plate, crankshaft pulley and engine front cover as previously described.

NOTE: If crankshaft is removed with cylinder head in position ensure all timing marks are realigned prior to re-assembly. This action will prevent possible interference upon re-assembly between valves and pistons.

3. Remove the oil pan, oil pump tube and balancer as previously described.
4. Remove the connecting rod caps, main bearing caps and liners and identify to facilitate re-assembly.
5. Carefully remove crankshaft from cylinder block.

Inspection and repair

NOTE: Current production engines may have a crankshaft with main or crankpin journals ground 0.010 in (0.25mm) undersize. These are identified with the letters 010 MUS and or 010 PUS respectively, letters being stamped on one of the crankshaft counter balance weights.

1. If crankshaft timing gear teeth are worn or damaged replace as necessary as described.
2. Wash the crankshaft and drilled passages in a suitable solvent. Dress minor imperfections using an oil stone but for severely marked journals machine to the next undersize bearing size.

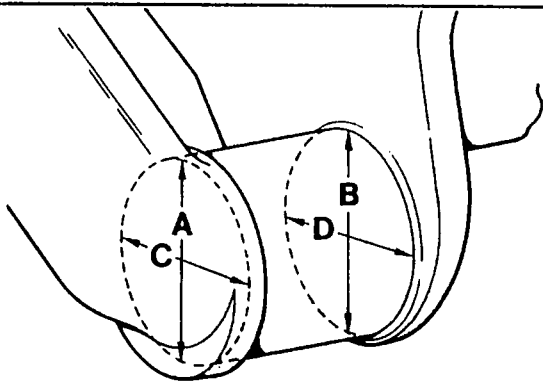

69

R1-62 Ω

Measuring Crankshaft Journal

3. Measure diameter of each journal, Figure 69, in four places to determine out-of-round, taper, or wear. Measuring A compared with B indicates vertical taper. Measuring C compared with D indicates horizontal taper. Measuring A and B compared with C and D indicates journal out-of-round.
4. If the journal exceeds specified limits refer to "Specifications" and refinish journal to the next undersize bearing.

5. Examine the rear oil seal journal for score marks, remove minor imperfections with fine emery cloth and if severely damaged renew the crankshaft.

BALANCER GEAR

NOTE: Inspect the balancer gear for wear or damage to teeth, if damage or wear is evident a new crankshaft must be fitted.

1. Check the crankshaft bearing clearance using a plastigauge as follows.

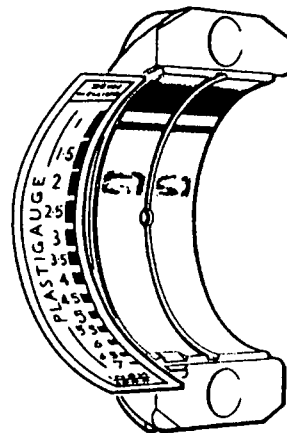

70

R1-64 Ω

Checking Bearing Clearance

2. Position a piece of correct size plastigauge across the full width of the bearing cap, approximately 0.25 in (6.35mm) off centre, Figure 70.
3. Install the cap and tighten bolts to 110 lbf ft (149N m) 15.2 kgf m.
4. Remove the cap and use the scale to check the width of the flattened plastigauge, Figure 70.
5. Widest point of gauge establishes the minimum clearance.
6. Narrowest point of gauge establishes maximum clearance. The difference between the two readings is the taper.

NOTE: Normally main bearing journals wear evenly and will not be out-of-round, but if a liner which is to specification is fitted to an out-of-round journal, ensure liner suits maximum diameter of journal.

7. If these combinations of liners do not produce specified clearance refinish crankshaft and fit undersize bearings.

IMPORTANT: Engines may be assembled with liners of different material, but liners of the same material must be used on the same journal.

8. Position the bearing liners and caps in the block and coat with oil. If the crankshaft has been refinished, fit correct undersize bearing liners.
9. Ensure the bearing surfaces are clean and bearing liner tangs align with slots in the block and cap.

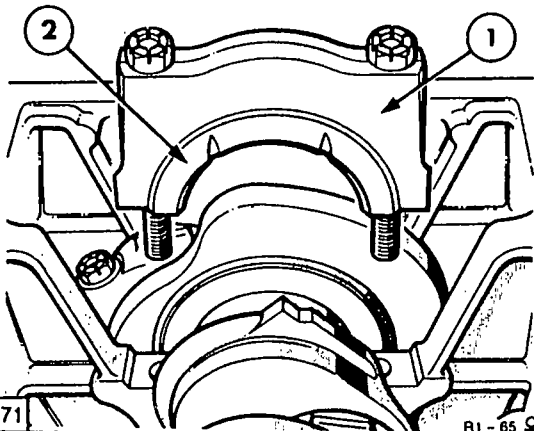

Thrust Bearing Installation

1. Thrust Bearing Cap
2. Liner

10. Align the timing mark on the crankshaft gear with that of the camshaft idler gear and install the crankshaft. Install a thrust bearing cap with flange type bearing liner first, installing remaining bearing caps to their original location, Figure 71.
11. Tighten all bearing caps (except thrust bearing cap, leave finger tight) to a torque of 145 lbf ft (197N m) 19.5 kgf m.
12. Pry the crankshaft forward against thrust surface of bearing, hold crankshaft forward and pry bearing cap rearwards taking care not to pry against flange of bearing liner. This will align thrust surfaces of both halves of bearing, hold forward pressure on crankshaft and tighten bearing cap bolts to a torque of 145 lbf ft (197N m) 19.5 kgf m.
13. Check crankshaft end play with a dial indicator gauge, pry crankshaft towards front of engine and set dial indicator to zero. Pry crankshaft towards rear of engine and note reading on dial. If end play exceeds 0.004–0.008 in (0.10–0.20mm) fit a new thrust bearing liner, Figure 72.

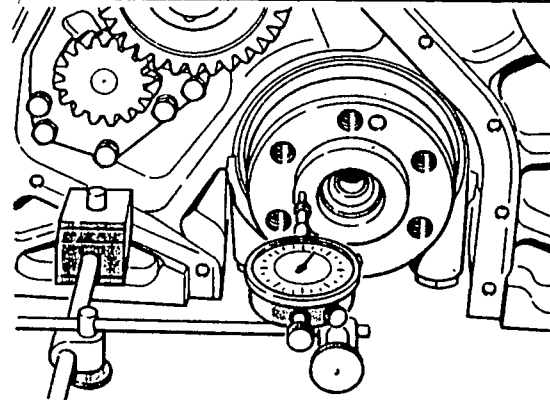

72

R1-66 5G

Measuring Crankshaft End Play

1. Dial Indicator

14. If the end play is less than specification check thrust bearing for burrs, scratches or dirt and re-align thrust bearing as in paragraph 12.
15. Install rear crankshaft oil seal as previously described in back plate removal.

NOTE: Do not pre-install seal into retainer. To ensure seal concentricity, it must be assembled with rear plate and installation tool when fitted to crankshaft.

CAMSHAFT REMOVAL

1. Remove the engine front cover and cylinder head.
2. Check the camshaft end play, see "Timing Gears Section" and remove gear. Install a new thrust plate prior to re-assembly.
3. After removal of the flywheel and rear cover, remove the camshaft oil pump drive gear.
4. Invert the engine on the stand, if camshaft bearings are to be replaced and remove the oil pan.
5. Carefully withdraw the camshaft from the rear of engine.

NOTE: With 4 cylinder camshafts, 3 sets of bearing shells are fitted. With 6 cylinder camshafts, 5 sets of bearing shells are fitted.

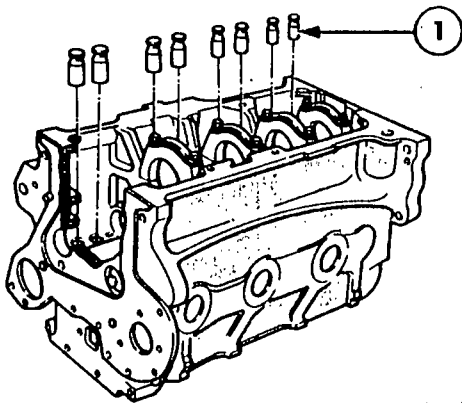

73

R1-67 9G

Camshaft Tappet Assembly

1. Tappets

6. Lift out the tappets, Figure 73 and place in a numbered rack for re-assembly.

Inspection and repair

1. Inspect the camshaft journals and lobes, for damage, pitting or heat discoloration. If any of these conditions exist install a new camshaft.
2. Inspect the oil pump drive gear on camshaft for broken or worn teeth and mating gear on oil pump. If any wear or damage is apparent fit new gears.
3. Check each tappet, Figure 73, for wear or damage and check diameters, if not to specification renew:
0.9900–0.9910 in (25.15–25.17mm).
4. Measure the diameter and out-of-round condition of bearing journals, if exceeded fit a new camshaft:
2.389–2.390 in (60.693–60.719mm).

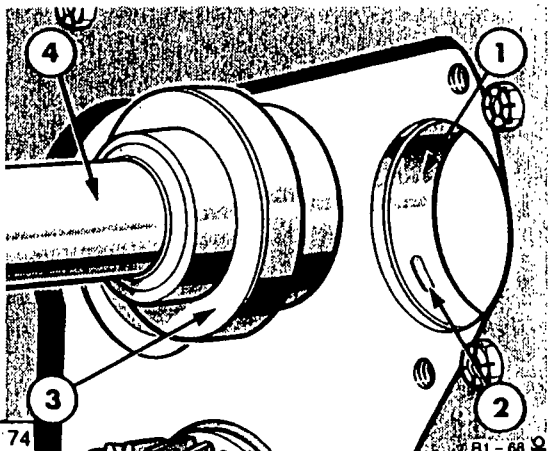

74

R1-68 Q

Camshaft Bearing Removal and Installation

- | | |
|---------------------|----------------------|
| 1. Camshaft Bearing | 3. Tool No 6203/1255 |
| 2. Oil Hole | 4. Handle N6261-A |

1. Inspect the camshaft bearings for wear or damage. Measure the clearance between the internal diameter of bearing and outside diameter of respective journal, 0.001–0.003 in (0.025–0.076mm).
2. If specification is exceeded install new bearings using Remover/Replacer Tool No. FT 6203, or 1255 and handle, Tool No N6261-A or 1442, Figure 74.
3. To remove, position tool against bearing to be removed and attach handle, driving bearing from bore.
4. To install, align oil holes of new bearing with holes in block and drive bearing into bore using tools as described.

NOTE: A positive alignment check can only be made with crankshaft removed when an 0.018 in (4.6mm) rod can be passed down the oil passage from the crankshaft main bearing. Liner is correctly positioned when end of rod passes through oil hole in the liner.

Installation

1. Apply petroleum jelly to each tappet foot and coat tappet body with oil. Install tappets in bores from which they were removed.
2. Oil camshaft journals and apply petroleum jelly to the cam lobes and install camshaft into engine.
3. Install new spacer and keyway on end of camshaft.
4. Install camshaft gear and align the camshaft gear timing mark and recheck end play.
5. Apply sealant ESE-M2G-114A to the sealing flange of the front cover plate on re-assembly.

THERMOSTAT REMOVAL

1. Drain the coolant system below that of the level of the thermostat housing, where a cab is fitted shut off heater hose tap, Figure 1.
2. Remove the thermostat housing retaining bolts and move the housing with tube attached to one side.

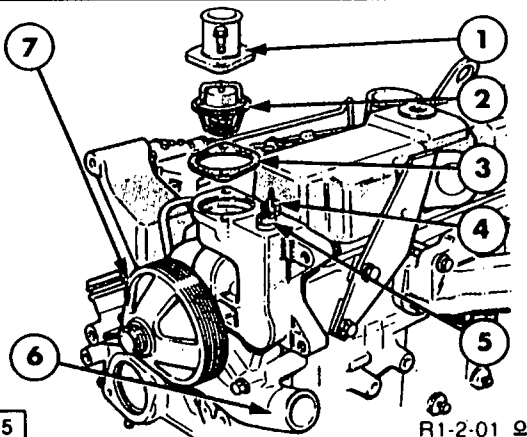

Water Pump Assembly

1. Thermostat Housing
2. Thermostat
3. Gasket
4. Temperature Sender Warning Light
5. Temperature Sender Gauge
6. Water Inlet
7. Water Pump Pulley

3. Withdraw the thermostat from the housing along with the gasket, Figure 5.

Inspection and Repair

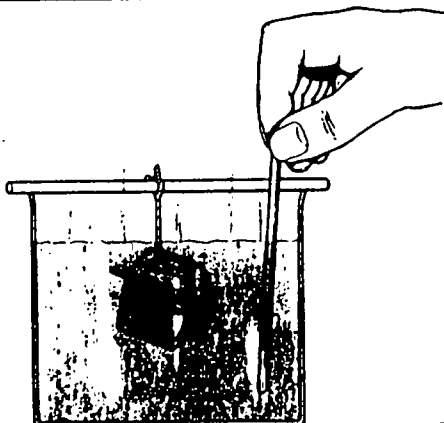

Checking the Thermostat

1. Place the thermostat in a container of water and raise the temperature to 212°F (100°C). If the thermostat fails to open when hot, or close properly when cooled, it must be replaced, Figure 6.

Installation

Installation of the thermostat is the reverse of the removal procedure but observing the following:-

1. Coat a new gasket with sealer and position in the recess on the thermostat housing, prior to installing the thermostat.
2. Coat the edge of the thermostat with grease and install, with the heat element located in the cylinder head, Figure 5.
3. Refit the thermostat housing and torque the two bolts to 15–21 lbs ft (20–28Nm) 2–3 kgf m.

WATER PUMP REMOVAL

1. Drain the cooling system.
2. Remove the radiator.
3. Loosen or lever the fan belt tensioner to ease the tension and remove the fan belt from the vehicle.

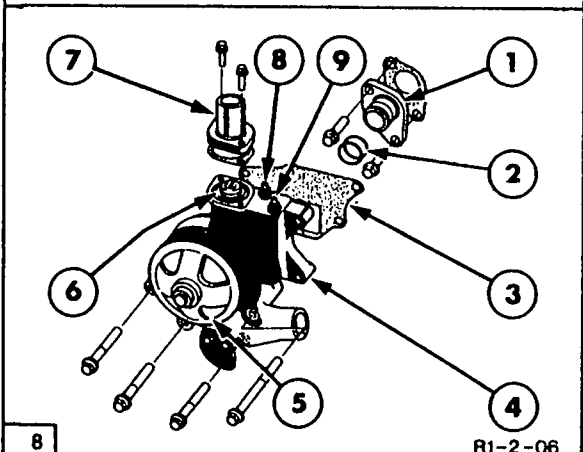

Water Pump Assembly

4. Withdraw the four bolts which pass through the water pump and into the block and slide the pump forward and away from its rear connector, removing the two sealing 'O' rings, Figure 8.
5. Alternatively withdraw six bolts, four in the water pump and two in the pump to block connector and remove from the engine as a complete unit, discarding the gaskets, Figure 8.

Disassembly

1. To remove the fan and clutch assembly hold the pump pulley in a fixed position, and placing an open ended spanner on the nut to the rear of the clutch assembly spacer, loosen the nut in a clockwise direction.

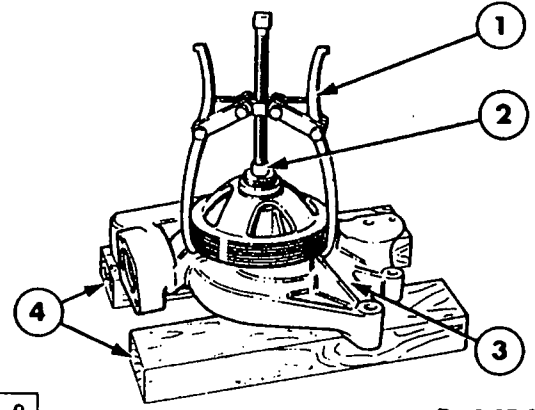

Water Pump Pulley Removal

2. Using a puller Tool No. 1002 or 9198 and a sleeve slightly smaller than the pulley shaft, ease the pulley from its shaft, Figure 9.

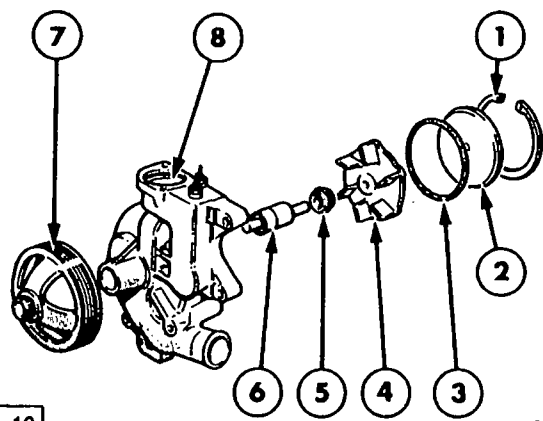

Water Pump Disassembled

3. Using a pair of heavy snap ring pliers, remove the snap ring from the rear of the pump body. Carefully ease out the backplate. Remove and discard the 'O' ring, Figure 10.

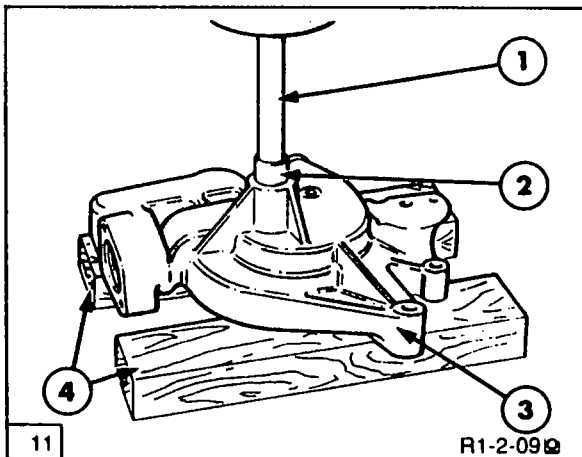

11

R1-2-09

Impeller/Shaft Assembly Removal

- | | |
|-----------|--------------|
| 1. Press | 3. Pump Body |
| 2. Sleeve | 4. Supports |

1. To remove the impeller/shaft assembly, place the pump body impeller side down. Support the pump in a manner to allow the impeller diameter to drop clear of the pump as it is pressed out from the pump body, Figure 11.

NOTE: Apply pressure to the outer bearing race and shaft simultaneously to remove, using the correct tool. Do not press the centre shaft only as the shaft may move, leaving the outer bearing case in the pump body.

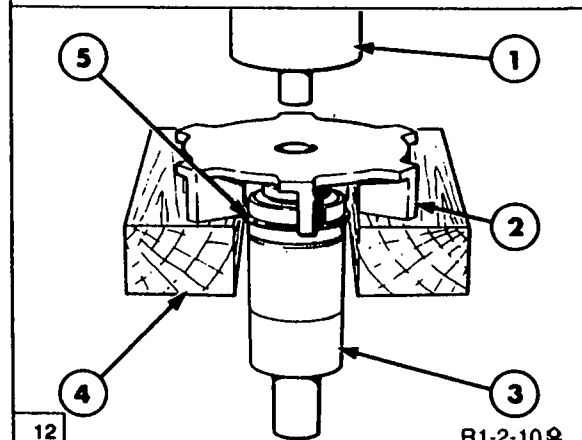

12

R1-2-10

Impeller Shaft Removal

- | | |
|---------------------|------------------|
| 1. Press | 4. Supports |
| 2. Impeller | 5. Seal Assembly |
| 3. Bearing Assembly | |

2. With the impeller/shaft assembly removed from the pump, place the impeller on supports and press out the shaft assembly from the impeller, Figure 12.

3. The seal assembly attached to the bearing shaft is not removable or servicable. During the manufacturing process the seal is pressed onto the shaft and is destroyed on removal, this is to meet pre load conditions and maintain an effective water seal.

Inspection and Repair

1. Check the bearing shaft and seal assembly for signs of wear or leaks and if evident, the assembly must be replaced with new parts.
2. The impeller should be checked for worn or damaged vanes and must be replaced if not to an acceptable standard.
3. Clean and check the pump body for signs of cracks, erosion or leaks. If any of these faults are in evidence and likely to cause pump failure at a later date, the pump body must be repaired or replaced with a new one.

Re-Assembly

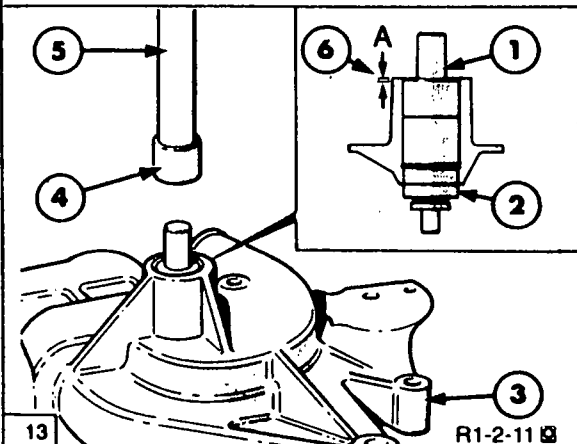

13

R1-2-11

Water Pump Bearing Installation

- | | |
|---------------------|------------------|
| 1. Bearing Assembly | 4. Sleeve |
| 2. Seal Assembly | 5. Press |
| 3. Pump Housing | 6. Reference "A" |

1. To install the bearing into the pump body, place the body rear face down onto a flat surface. Install the bearing with the longer stepped end of the shaft in the body and using a sleeve that contacts the bearing outer race only, press the bearing into the body. Once installed in the body the bearing case end face must be flush with the pump front face to within 0.000–0.006 in (0.00–0.076mm), Reference "A", Figure 13.

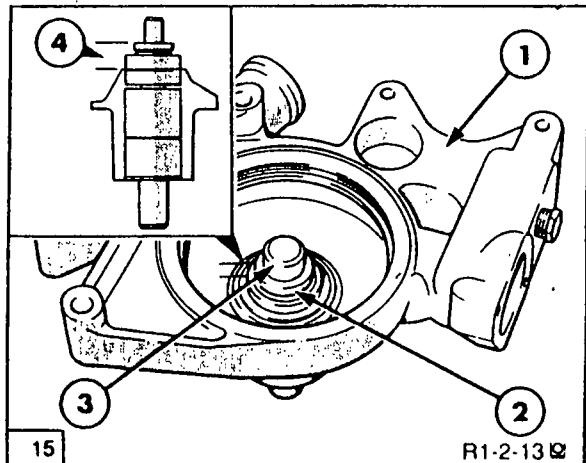

Water Pump Seal Installed

- | | |
|------------------|---------------------|
| 1. Pump Housing | 3. Bearing Assembly |
| 2. Seal Assembly | 4. Reference "A" |

3. With the seal installed correctly, the seal working height should be maintained at 0.470–0.490 in (11.9–12.4mm), Reference "A", Figure 15.

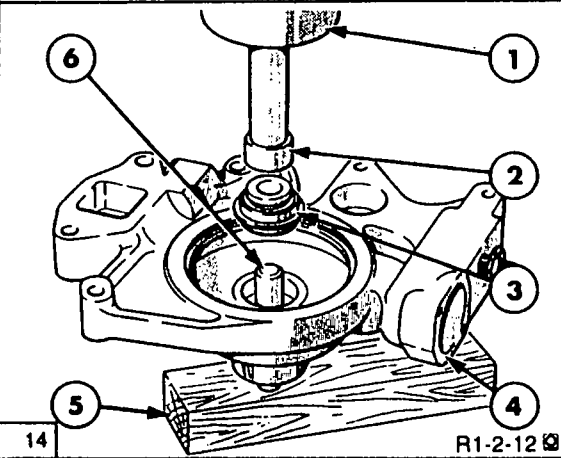

Water Pump Seal Installation

- | | |
|------------------|---------------------|
| 1. Press | 4. Pump Housing |
| 2. Sleeve | 5. Support |
| 3. Seal Assembly | 6. Bearing Assembly |

2. With the water pump placed front face down and the shaft supported, place the seal assembly on the end of the shaft, with its smallest diameter uppermost. To insert the seal assembly place Tool No. FT 6209 or 4672 over the seal and press, until the lip on the seal body seats on the pump body, Figure 14.

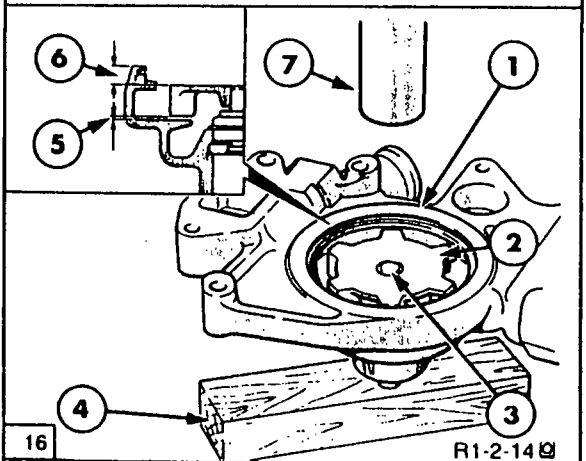

Water Pump Impeller Installed

- | | |
|---------------------|------------------|
| 1. Pump Housing | 5. Reference "A" |
| 2. Impeller | 6. Reference "B" |
| 3. Bearing Assembly | 7. Press |
| 4. Support | |

4. With the water pump rear face up and the shaft supported, place the impeller over the shaft and press the impeller into the water pump body. Installed correctly the face of the impeller fins to the operating face of the water pump should be 0.010–0.035 in (0.25–0.88mm), Reference "A" Figure 16.

5. Check the dimension from the rear face of the impeller to the rear face of the pump. The dimension should be maintained at 0.46–0.485 in (11.6–12.2mm), Reference "B", Figure 16.

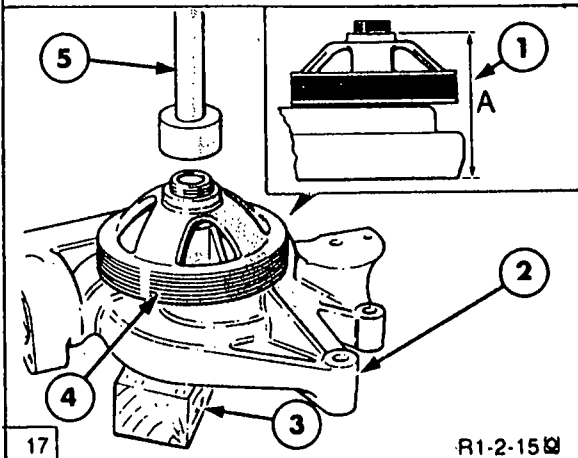

17

R1-2-15

Water Pump Pulley Installed

- | | |
|------------------|-----------|
| 1. Reference "A" | 4. Pulley |
| 2. Pump Housing | 5. Press |
| 3. Support | |
6. With the pump rear face down and the shaft supported, press the pulley onto the shaft ensuring that the pulley front face to the rear face of the pump dimension is, 5.091–5.101 in (127–129mm), Reference "A", Figure 17.
7. Ensure a new 'O' ring is fitted and place the water pump backplate in position, refitting the snap ring into its groove, Figure 10. Make sure the water pump pulley/impeller assembly rotates freely by hand prior to re-assembly. If not disassemble and recheck the relevant dimensions.

Installation

1. Installation of the water pump to the engine is the reverse of disassembly, but observing the following requirements.

Clean the block face and fit a new gasket between the connector and block face, Figure 8, then torque the two bolts to 15–21 lbs ft (20–28Nm) 2.0–2.9 kgf m.

Fit two new 'O' rings over the connector outlet port as required, Figure 8.

Place the water pump over the connector and install and torque the four pump bolts to 45–50 lbs ft (61–68Nm) 6.2–6.9 kgf m.

Ensure the fan belt tensioner pulley rotates freely and the swinging arm of the tensioner returns to rest freely. Gently lever the arm up to enable the fan belt to be seated in the grooves on the pulleys. Refit the fan blade assembly.

After installation of the radiator, refill the cooling system as previously described and run the engine checking for leaks.

FITTING TOLERANCES - DATA

CYLINDER BLOCK

Taper of Cylinder Bore	0.001 in (0.025mm) Repair Limit 0.005 in (0.127mm) Wear Limit
Cylinder Bore out of Round	0.0015 in (0.03mm) Repair Limit 0.005 in (0.127mm) Wear Limit
Cylinder Bore Diameters	4.4007-4.4032 in (111.778-111.841mm)
Rear Oil Seal Bore Diameter	5.542-5.546 in (140.77-140.87mm)
Block to Head Surface Flatness	0.003 in (0.08mm) in any 6 in (152mm) 0.001 in (0.03mm) in any 1 in (25.40mm)

CYLINDER HEAD

Valve Guide Bore Diameter	0.3728-0.3738 in (9.469-9.495mm)
Head to Block Surface Flatness	0.001 in (0.03mm) in any 1 in (25.4mm), or 0.005 in (0.127mm) overall limit

EXHAUST VALVES

Face Angle	44°15'-44°30' Relative to the Head of Valve
Stem Diameter	Standard : 0.3701-0.3709 in (9.401-9.421mm) 0.003 in (0.076mm) Oversize : 0.3731-0.3739 in (9.477-9.497mm) 0.015 in (0.38mm) Oversize : 0.3851-0.3859 in (9.781-9.802mm) 0.030 in (0.76mm) Oversize : 0.4001-0.4009 in (10.163-10.183mm)
Head Diameter	1.688-1.698 in (42.88-43.13mm)
Stem to Guide Clearance	0.0019-0.0037 in (0.048-0.094mm)
Lash Clearance (Cold)	0.017-0.021 in (0.43-0.53mm)

INTAKE VALVES

Face Angle	29°15'–29°30' Relative to Head of Valve
Stem Diameter	Standard : 0.3711–0.3719 in (9.426–9.446mm) 0.003 in (0.076mm) Oversize : 0.3741–0.3749 in (9.502–9.522mm) 0.015 in (0.381mm) Oversize : 0.3861–0.3869 in (9.807–9.827mm) 0.030 in (0.762mm) Oversize : 0.4011–0.4019 in (10.188–10.208mm)
Head Diameter	1.865–1.875 in (47.37–47.63mm)
Stem to Guide Clearance	0.0009–0.0027 in (0.023–0.069mm)
Lash Clearance (Cold)	0.014–0.018 in (0.36–0.46mm)

VALVE SPRINGS

Number per Valve	1
Free Length	2.39 (60.7mm)
Length, loaded at 61.69 lb (27.7–31.3kg)	1.900 in (48.26mm)
Length, loaded at 135–153 lb (61–69kg)	1.405 in (35.69mm)

VALVE TIMING

Intake Opening	12° Before Top Dead Centre
Intake Closing	38° After Bottom Dead Centre
Exhaust Opening	48° Before Bottom Dead Centre
Exhaust Closing	12° After Top Dead Centre

VALVE INSERTS

Insert Oversize	Exhaust Valve Insert Counterbore Diameter In Cylinder Head	Intake Valve Seat Insert Counterbore Diameter In Cylinder Head
0.010 in (0.254mm)	1.739–1.740 in (44.17–44.20mm)	1.969–1.970 in (50.01–50.04mm)
0.020 in (0.508mm)	1.749–1.750 in (44.42–44.45mm)	1.979–1.980 in (50.27–50.29mm)
0.030 in (0.762mm)	1.759–1.760 in (44.68–44.70mm)	1.989–1.990 in (50.52–50.55mm)

VALVE SEATS

Exhaust Valve Seat Angle	45°00' – 45°30'
Intake Valve Seat Angle	30°00' – 30°30'
Interference Valve Face Angle to Valve Seat Angle	0°30' – 1°15'
Concentricity with Guide Diameter	0.002 in (0.051mm) Total Indicator Reading Max
Seat Width Exhaust Valve Intake Valve	0.072–0.092 in (1.8–2.3mm) 0.078–0.098 in (1.9–2.5mm)

CAMSHAFT IDLER GEAR

Number of Teeth	47
End Play	0.003–0.014 in (0.076–0.35mm)
Bushing Inside Diameter	2.005–2.0015 in (50.813–50.838mm)
Adaptor Outside Diameter	1.9985–1.9990 in (50.762–50.775mm)
Backlash with Crankshaft Gear	0.001–0.009 in (0.025–0.23mm)
Backlash with Camshaft Gear	0.001–0.015 in (0.025–0.381mm)
Backlash with Fuel Injection Pump	0.001–0.012 in (0.025–0.30mm)

CAMSHAFT GEAR

Number of Teeth	52
Timing Gear Backlash	0.001–0.015 in (0.025–0.38mm)

ROCKER ARM SHAFT

Shaft Diameter	1.000–1.001 in (25.40–25.43mm)
Shaft Support Internal Diameter	1.002–1.004 in (25.45–25.20mm)

ROCKER ARM

Inside Diameter 1.003–1.004 in (25.48–25.50mm)

TAPPETS

Clearance to Bore 0.0006–0.0021 in (0.015–0.053mm)

Tappet Diameter 0.9889–0.9894 in (25.118–25.130mm)

Tappet Bore Diameter 0.9900–0.9910 in (25.15–25.17mm)

CAMSHAFT

Bearing Journal Diameter 2.3895–2.3905 in (60.693–60.719mm)

Bearing Clearance 0.0010–0.0030 in (0.025–0.076mm)

End Play 0.0020–0.0070 in (0.051–0.18mm)

CONNECTING RODS

Small End Bushing (Internal Diameter)
Naturally Aspirated 1.5005–1.5008 in (38.113–38.120mm)
Turbocharged 1.6255–1.6258 in (41.288–41.259mm)

Clearance Bushing to Piston Pin 0.0005–0.0010 in (0.013–0.025mm)

Side Float 0.0050–0.0130 in (0.13–0.33mm)

Maximum Twist 0.0120 in (0.30mm)

Maximum Bend 0.0040 in (0.10mm)

PISTON PIN

Outside Diameter
Normally Aspirated Engine 1.4998–1.5000 in (38.095–38.100mm)
Turbocharged Engine 1.6248–1.6250 in (41.270–41.275mm)

PISTONS

Skirt to Cylinder Clearance Naturally Aspirated & Turbocharged	0.0055–0.0065 in (0.140–0.165mm)
Taper (Out of Round)	0.0025–0.0050 in (0.063–0.127mm)
Grading Diameter (at Right Angles to Piston Pin)	4.3951–4.3991 in (111.64–111.74mm) in increments of 0.0005 in (0.0127mm)
Piston Pin Clearance	0.00012–0.00055 in (0.0030–0.0140mm) at 70°F (21°C)
Piston Crown to Block Face: Naturally Aspirated Turbocharged	0.011–0.023 in (0.28–0.58mm) 0.0–0.012 in (0.0–0.3mm)
PISTON RINGS	
Compression; Number and Location	2 of, 1st and 2nd from the top of the piston
Naturally Aspirated: Top Compression Ring 2nd Compression Ring	Parallel Sides–Inner Chamfer or no Chamfer Straight Face–Inner Step
Turbocharged: Top Compression Ring 2nd Compression Ring	Keystone Tapered With Internal Chamfer to Top Straight Face–Inner Step
Oil Control: Number and Location Type	1 of, –Directly above the Piston Pin, Slotted With Expander
Side Face Clearance To Ring Groove: Top Compression Ring 2nd Compression Ring Oil Control Ring	0.0044–0.0061 in (0.112–0.155mm) 0.0039–0.0056 in (0.099–0.142mm) 0.0024–0.0041 in (0.061–0.104mm)
Gap Width: Top Compression Ring 2nd Compression Ring Oil Control Ring	0.015–0.033 in (0.38–0.84mm) 0.026–0.044 in (0.66–1.12mm) 0.015–0.033 in (0.38–0.84mm)

CRANKSHAFT

Main Journal Diameter—Blue —Red	3.3713–3.3718 in (85.631–85.644mm) 3.3718–3.3723 in (85.644–85.656mm)
Main Journal Length (except thrust, rear or intermediate)	1.455–1.465 in (36.96–37.21mm)
Main Journal Wear Limits	0.005 in (0.127mm) Maximum
Main and Crankpin Fillet Radius	0.12–0.14 in (3.048–3.556mm)
Thrust Bearing Journal Length	1.459–1.461 in (37.06–37.11mm)
Intermediate Bearing Journal Length	1.455–1.465 in (36.96–37.21mm)
Rear Bearing Journal Length	1.495–1.515 in (37.97–38.48mm)
Crankpin Journal Length	1.678–1.682 in (42.62–42.72mm)
Crankpin Diameter – Blue — Red	2.749–2.7500 in (69.840–69.850mm) 2.750–2.7504 in (69.850–69.860mm)
End Play	0.004–0.008 in (0.10–0.20mm)
Crankpin Out of Round	0.0002 in (0.005mm) Total Indicator Reading
Taper Surface Parallel to Centre Line of Main Journal	0.0002 in (0.005mm)
Crankshaft Rear Oil Seal Journal Diameter	4.808–4.814 in (122.12–122.28mm)
Crankshaft Pulley Journal Diameter	1.750–1.751 in (44.45–44.48mm)
Crankshaft Timing Gear Journal Diameter	1.820–1.821 in (46.23–46.25mm)
Crankshaft Flange Runout	0.0015 in (0.038mm) Max

CRANKSHAFT DRIVE GEAR

Number of Teeth 26

MAIN BEARING

Liner Length (except Thrust Liner) 1.10–1.11 in (27.94–28.19mm)
 Liner Length (Thrust Liner) 1.453–1.455 in (39.91–39.96mm)
 Vertical Assembled Bearing Clearance 0.0021–0.0046 in (0.055–0.117mm)

CRANKPIN BEARINGS

Liner Length 1.40–1.41 in (35.56–35.81mm)
 Vertical Assembled Bearing Clearance 0.0014–0.0037 in (0.035–0.094mm)

CRANKSHAFT RE-GRINDING

When re-grinding a crankshaft the main and crankpin journal diameters should be reduced the same amount as the undersize bearings used, and the following dimensions apply. The rear end of the crankshaft should be located on the 60° Chamfer of the pilot bearing bore .

UNDERSIZE BEARING AVAILABLE**MAIN JOURNAL DIAMETERS**

0.002 in (0.051mm)	3.3693–3.3698 in (85.580–85.593mm)
0.010 in (0.254mm)	3.3618–3.3623 in (85.390–85.402mm)
0.020 in (0.508mm)	3.3518–3.3523 in (85.136–85.148mm)
0.030 in (0.762mm)	3.3418–3.3423 in (84.882–84.894mm)
0.040 in (1.016mm)	3.3318–3.3323 in (84.628–84.640mm)

UNDERSIZE BEARING AVAILABLE**CRANKPIN JOURNAL DIAMETERS**

0.002 in (0.051mm)	2.7476–2.7480 in (69.789–69.799mm)
0.010 in (0.254mm)	2.7400–2.7404 in (69.956–69.606mm)
0.020 in (0.508mm)	2.7300–2.7304 in (69.342–69.352mm)
0.030 in (0.762mm)	2.7200–2.7204 in (69.088–69.098mm)
0.040 in (1.016mm)	2.7100–2.7104 in (68.834–68.844mm)

CRANKSHAFT BALANCER

Gear Backlash	0.002–0.010 in (0.05–0.25mm)
Shaft to Bushing Clearance	0.0002–0.008 in (0.005–0.020mm)
Shaft Diameter	0.9895–1.000 in (25.133–25.400mm)
Backlash Between Balancer and Crankshaft Gear	0.002–0.008 in (0.05–0.20mm)
End Float Balancer Gear to Support	0.008–0.020 in (0.20–0.51mm)

FLYWHEEL

Runout of Clutch Face (between Outer Edge of Friction Surface and Mounting Bolt Holes)	0.005 in (0.127mm)
Ring Gear Runout	0.025 in (0.63mm)

OIL PUMP

Rotor Clearance	0.001–0.006 in (0.025–0.15mm)
Rotor to Pump Housing Clearance	0.006–0.011 in (0.15–0.28mm)
Rotor End Play	0.001–0.0035 in (0.025–0.089mm)
Pump Gear to Camshaft Gear Backlash	0.016–0.022 in (0.40–0.56mm)

OIL FILTER SUPPORT

Relief Valve, Operating Pressure	55–60 lbf/in ² (379–414 kpa)
Flow Rate	15–16.6 imp gals/min (18–20 US gals/min)

Temperature	Oil Viscosity and Type	API Classification	Engine Oil & Filter Change Period (hours)	
			4 CYL	6 CYL
Below –12°C (10°F)	Low Ash, SAE 5W Supplement 1 or Low Ash SAE 5W/20 Supplement 1 or SAE 10W–30	SF/CC	150	150
		SF/CC	150	150
		SF/CD	150	150
–12°C to 4°C (10°F to 40°F)	Low Ash, SAE 10W Series 3 or SAE 10W–30	SF/CD	300	300
		SF/CD	300	300
0°C to 32°C (32°F to 90°F)	Low Ash, SAE 20W Series 3 or SAE 10W–30	SF/CD	300	300
		SF/CD	300	300
Above 24°C (75°F)	Low Ash, SAE 30W Series 3	SF/CD	300	300

NOTE: When using diesel fuel with a sulphur content below 1.0% Series 3 diesel engine oil with an A.P.I. classification of CC may be used instead of CD oil, but the oil and filter interval must be reduced to 150 hours .

When using diesel fuel with a sulphur content between 1% and 1.3% use only oils listed above but reduce the oil and filter change period to every 50 hours .

ENGINE OIL CAPACITIES (Less Oil Filter)

Model	Imp Qts	U.S Qts	Litres
4 CYL	10.0	12.00	11.6
6 CYL	17.6	21.12	20.0

ENGINE OIL CAPACITIES (With Oil Filter)

Model	Imp Qts	U.S Qts	Litres
4 CYL	11.5	13.8	13.6
6 CYL	19.3	23.2	22.0

THERMOSTAT

Opening Temperature 174–181°F (79–83°C)
Fully Open 199–205°F (93–96°C)

WATER PUMP

Type Centrifugal

Drive Poly V Belt

FAN BELT

Belt Tension Maintained by Tensioner

COOLING FLUID

Use water with 50% of FIAT PARAFU 11 antifreeze. As an option, products having similar characteristics can be used, provided they comply with international standards SAEJ1034.

TORQUE VALUES

The following general nut and bolt installation torque requirements (lubricated) apply to any operation not previously listed.

INCH SERIES	lbf ft	Nm	Kgf m
1/4 - 20	8	11	1.1
1/4 - 28	8	11	1.1
5/16 - 18	14	19	1.9
5/16 - 24	17	23	2.3
3/4 - 16	23	31	3.2
3/4 - 24	33	45	4.6
7/16 - 14	48	65	6.6
7/16 - 20	55	75	7.6
1/2 - 13	65	88	8.9
1/2 - 20	75	102	10.4
9/16 - 18	90	122	12.4
5/8 - 18	138	187	19.0
CYLINDER BLOCK PLUGS			
1/4 - 27 NPT	8	11	1.1
1/4 - 18 NPT	22	29.8	3.0
3/4 - 18 NPT	28	38	3.8
3/4 - 14 NPT	20	27	2.7
Balancer Bolts	85	115	12.0
Main Bearing Bolts	145	197	20.0
Connecting Rod Bolts	110	149	15.2
Cylinder Head Bolts (with Engine Cold)	160	217	22.0
Intake Manifold-to-Cylinder Head	26	35	3.5
Exhaust Manifold-to-Cylinder Head	28	38	3.9
Exhaust Pipe-to-Flange	23	31	3.2
Flywheel-to-Crankshaft	145	197	20.0
Oil Pan Drain Plug	30	41	4.2
Valve Rocker Cover Bolts	18	24	2.4
Crankshaft Pulley-to-Crankshaft	210	224	23.0
Self-Locking Screw - Valve Rocker Arm	18	24	2.4

TORQUE VALUES – VARIOUS	lbf ft	Nm	Kgf m
Injector Attachment Bolts	17	23	2.3
Cover Bolts (Blanks Oil Drilling)	23	31	3.1
Oil Pump to Block	17	23	2.3
Water Pump-to-Cylinder Block	48	35	3.6
Water Pump Cover-to-Pump	20	27	2.8
Oil Pan-to-Cylinder Block (Cast)	28	38	3.9
Injector Line Nuts	18	24	2.4
Leak-off Tube Banjo Fitting Bolts	8	11	1.1
Injection Pump-to-Front Adaptor Plate	18	24	2.4
Camshaft Idler Drive Gear-to-Block	175	237	24.0
Front Adaptor Plate-to-Cylinder Block	18	24	2.4
Thermostat Housing Bolts	18	24	2.4
Camshaft Gear Bolt	51	69	7.0
Camshaft Rear Gear Plate Bolts	35	47	4.8
Oil Filter Adaptor Bolts	31	42	4.2
Oil Filter Mounting Bolt Insert	25	34	3.5
Starting Motor-to-Rear Adaptor Plate	23	31	3.2
Dynamic Balancer – Cylinder Block	86	117	11.8
Injection Pump-to-Gear Nut (4 cyl.)	58	79	8.0
Oil Pressure Switch Assembly	23	31	3.2
Turbocharger-to-Exhaust Manifold Nut	33	44	4.5
Single Fan to Pulley Nose Thread	21	27	2.8
Crankshaft Rear Oil Seal Retainer –			
Initial Tightening	9	12	1.2
Final Tightening	17	23	2.3
Thermostat Housing	18	24	2.4
Temperature Senders	15	20	2.0
Tensioner Pulley Bolt	40	54	5.5
Tensioner to Water Pump	40	54	5.5
Idler Pulleys	40	54	5.5
Pump Connector to Block	18	24	2.4
Water Pump to Block	48	65	6.5
Fan Blade to Support Body	17	23	2.3
Fan Blade Clutch to Support Body	78	105	10.5

SPECIAL TOOLS

DESCRIPTION	V.L. CHURCHILL TOOL No.	NUDAY TOOL No.	FNH TOOL No.
Adjustable Bridge Puller	518	9539	09539
Shaft Protectors	625-A	9212	09212
Step Plate Adaptors	630-S	9210	09210
Bushing Kit	818	9514	09514
Valve Guide Reamer Kit	FT.6202 (SW.502)	2136 (SW.502)	02136
Camshaft Bearings – Remover/Installer Handle	FT.6203 N6261-A	1255 (SW.506) 1442	01225 01442
Water Pump Seal Replacer	FT.6209	4672	T87T-6312-A
Connecting Rod Bush – Removal Installation			FNH 00035 OTC 134-00002
Crankshaft Seal Replacer Front Seal Rear Seal	630-16 FT 6212		T87T-6019-A FNH 01301

(Prior Tool Numbers, where applicable, shown in brackets)

TURBOCHARGER

DESCRIPTION AND OPERATION

Turbochargers are used to increase power by compressing (or densifying) the air that goes into the engine combustion chambers. Therefore the increased power comes from the additional fuel that the denser air accommodates during the combustion process.

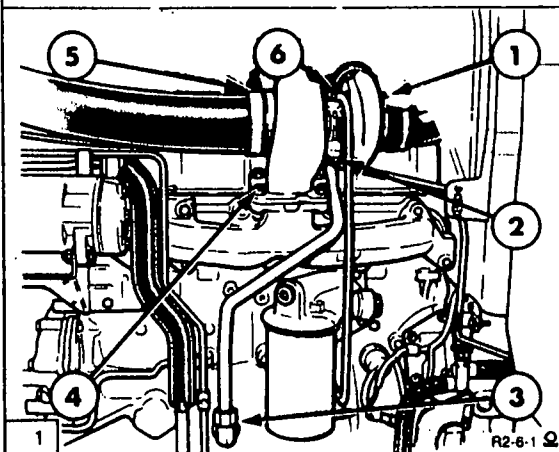

Turbocharger Installed

1. Air inlet Tube Clamps
2. Turbocharger Housing
3. Oil Return Tube to Block
4. Turbocharger to Manifold Bolts
5. Turbine Outlet Clamp
6. Oil Intake Tube to Turbocharger

The turbocharger when fitted, is mounted on the engine exhaust manifold, situated on the left hand side of the engine underneath the top hood, Figure 1.

The turbocharger consists of an exhaust gas driven turbine and air compressor wheels, mounted on opposite ends of a common shaft. The wheels are enclosed by a housing and the shaft by a centre housing, Figure 2.

The turbine is a centripetal (from outside to centre), radial inflow designed mechanism consisting of a cast turbine wheel shroud and a specially designed housing that encloses the wheel and directs the flow of gas through the turbine housing.

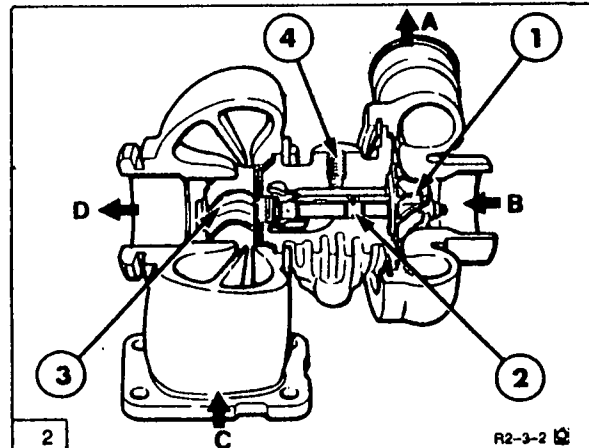

Turbocharger Cross Section

- A To intake manifold
- B From Air Cleaner
- C From Exhaust Manifold
- D To Exhaust Muffler
1. Compressor Wheel
2. Bearings
3. Turbine Wheel
4. Oil Supply to Bearing

The compressor is a centrifugal, radial out-flow mechanism consisting of a cast compressor wheel and a specially designed housing that encloses the wheel and directs the flow of air through the compressor.

The centre housing supports the compressor and turbine wheel shaft in a pair of identical bearings which contain oil holes for directing oil to the bearing bores and shaft journals. Passages drilled in the centre housing provide for directing the oil, supplied by the engine from the inlet port to oil grooves machined in the bearing bores which align with holes in the bearings.

Piston rings are installed at each end of the shaft, between the bearing and the adjacent turbine or compressor wheel, to prevent lubricating oil from entering the turbine and the compressor area.

During operation of a turbocharged engine, exhaust gas from the engine exhaust manifold flows into the turbine. The exhaust gas pressure and the heat energy extracted from the gas, cause the turbine wheel to rotate which in turn, causes the compressor wheel to rotate.

The cooled and expanded exhaust gas leaving the turbine wheel, is directed by the turbine housing to the engine exhaust system, which expels it to the atmosphere.

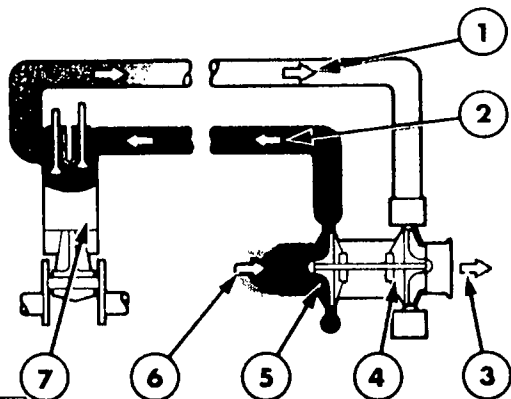

3

R2-3-4 Ω

Turbocharger Engine Schematic

1. Engine Exhaust Gas Flow
2. Compressed Air Flow
3. Exhaust Gas Discharge
4. Turbine
5. Compressor
6. From Air Cleaner
7. Engine Cylinder

Rotation of the compressor wheel causes ambient air from the engine air cleaner to be drawn into the compressor housing, where it is compressed and delivered to appropriate ducting which delivers it to the engine intake manifold, Figure 3.

The increased volume and density of the air thus delivered to the engine cylinders permit a corresponding increase in the volume of fuel that can be introduced into the cylinders while maintaining the air to fuel ratio required for proper combustion. Since engine power output is a function of the volume of fuel burned, the increase in the volume of fuel introduced as a result of turbocharger operation results in an increase in engine power output.

IMPORTANT: To ensure adequate lubrication of the turbocharger, allow the engine to idle at 1000 rev/min for approximately one minute after starting the engine.

To allow the turbocharger, and exhaust manifold, to cool down and prevent any possible distortion of components, idle the engine at 1000 rev/min for approximately one minute, before stopping the engine.

FAULT FINDING

It is important when fault finding a suspected turbocharger malfunction, to keep in mind that a turbocharger cannot compensate for incorrect engine operating procedures.

Deficiencies of the engine air intake fuel or exhaust systems, or for damaged engine components, such as valves, pistons, rings liners, etc. Replacing a good turbocharger with another will not correct engine deficiencies.

Consequently, systematic fault finding of a suspected turbocharger failure is essential for two very good reasons.

- 1, it must be determined what, if anything, is wrong with the turbocharger so that it can be repaired.
- 2, it must be determined what action will prevent a recurrence of the failure.

In many cases the evidence required to determine the cause of a malfunction is destroyed in the process of removing the turbocharger from the engine.

For example, if a turbocharger failed as the result of a faulty installation (such as loose duct connections that permitted ingestion of dirt by the compressor) this would not be evident once the turbocharger was removed from the engine.

Furthermore, failure to take appropriate steps to assure correct installation (such as repairing or replacing defective clamps or ducting) could cause the replacement unit to fail in a similar manner.

The following Fault Finding Chart contains information pertaining to probable failure modes of turbocharged engines, possible causes for such failures and the maintenance action required to remedy each possible cause.

It is not represented that this information is all inclusive, but should be considered as representative of the methods or techniques that should be used during fault finding.

In general fault finding procedures that can be performed with the least effort and least amount of time should be performed first.

No removal or disassembly procedures should be performed until all visual inspections and sensory tests (sight and feel) that can be accomplished with the turbocharger have been performed.

The possible causes and procedures are generally arranged in order of ease accomplishment.

SYMPTONS	POSSIBLE CAUSES
<p>Engine lacks power, or emits black smoke</p>	<ol style="list-style-type: none"> 1. Dirty Air Cleaner 2. Loose Compressor to intake manifold connections 3. Leak at engine intake at turbocharger mounting flange 4. Turbocharger rotating assembly binding 5. Air cleaner to turbocharger duct restricted 6. Compressor to intake manifold duct restricted 7. Engine exhaust system restricted 8. Engine malfunction (rings, pistons, valves)
<p>Seal leaks at compressor end of turbocharger</p>	<ol style="list-style-type: none"> 1. Dirty air cleaner 2. Restricted duct between air cleaner and turbocharger 3. Loose compressor to intake manifold dust connections 4. Leaks at engine intake manifold 5. Restricted turbocharger oil drain line 6. Plugged engine crankcase breather 7. Worn or damaged compressor wheel (worn bearings, bores or journals) 8. Excessive piston blowby or high internal crankcase pressure

SYMPTOMS	POSSIBLE CAUSES
Seal leaks at turbine end of turbocharger	<ol style="list-style-type: none"> 1. Excessive pre-oiling 2. Plugged engine crankcase breather 3. Restricted turbocharger oil drain line 4. Sludged or coked centre housing 5. Worn turbocharger bearings, bearing bores, or shaft journals
Engine exhaust emits blue smoke	<ol style="list-style-type: none"> 1. Dirty air cleaner 2. Loose compressor to intake manifold connections 3. Leak at engine intake manifold 4. Plugged engine oil filter 5. Restricted duct between air cleaner and turbocharger compressor 6. Seal leak at compressor end of turbocharger 7. Engine malfunction (rings, pistons, valves, etc)
Worn turbocharger bearings, bores or journals	<ol style="list-style-type: none"> 1. Inadequate pre-oiling following turbocharger installation or engine lubrication servicing 2. Contaminated or improper grade of engine oil used in engine 3. Insufficient oil supplied to turbocharger due to oil lag 4. Restricted turbocharger oil feed line 5. Plugged engine oil filter 6. Abrasive wear due to coked material in turbocharger
Excessive engine oil consumption	<ol style="list-style-type: none"> 1. Wrong type or viscosity of engine lubricating oil 2. Seal leaks at compressor end of turbocharger (indicated by oil in housing or on wheel) 3. Oil in engine exhaust manifold (caused by malfunction of rings, pistons, valves, etc)

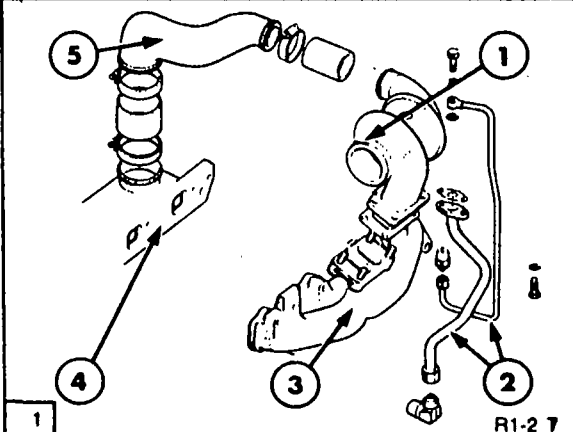
SYMPTONS	POSSIBLE CAUSES						
Noisy turbocharger	<ol style="list-style-type: none"> 1. Dirty air cleaner 2. Foreign material or object in compressor to intake manifold duct 3. Foreign object in engine exhaust system 4. Carbon build up in turbine housing 5. Turbocharger rotating assembly binding or dragging 6. Insufficient lubrication oil, due to malfunction of oil pump 						
Turbocharger rotating assembly binding or dragging	<ol style="list-style-type: none"> 1. Damaged compressor wheel 2. Damaged turbine wheel 3. Compressor or turbine wheel rubbing on housing due to worn bearings, shaft journals, or bearing bores 4. Excessive dirt build up in compressor (housing or wheel) 5. Excessive carbon build up behind turbine wheel 6. Sludged or coked centre housing (check engine lubrication system) 						
<p>OVERHAUL Removal</p> <ol style="list-style-type: none"> 2. Remove exhaust muffler. 3. Loosen and detach the top hood. 4. Disconnect the air cleaner to the turbocharger tube, and the turbocharger to intake manifold tube, by loosening the tube hose clamps, Figure 1. 	 <p style="text-align: right;">R1-2 7</p> <p style="text-align: center;">Turbocharger Assembly</p> <table style="width: 100%; border: none;"> <tr> <td style="width: 50%; border: none;">1. Turbocharger Housing</td> <td style="width: 50%; border: none;">3. Exhaust Manifold</td> </tr> <tr> <td style="border: none;">2. Oil feed and Return Pipes</td> <td style="border: none;">4. Inlet Manifold</td> </tr> <tr> <td style="border: none;"></td> <td style="border: none;">5. Inlet Hoses and Tubes</td> </tr> </table>	1. Turbocharger Housing	3. Exhaust Manifold	2. Oil feed and Return Pipes	4. Inlet Manifold		5. Inlet Hoses and Tubes
1. Turbocharger Housing	3. Exhaust Manifold						
2. Oil feed and Return Pipes	4. Inlet Manifold						
	5. Inlet Hoses and Tubes						

5. Disconnect the oil supply and return tubes from the turbocharger. Cap the ends of the tubes and the oil ports of the turbocharger to prevent entry of foreign material, therefore, preventing future bearing failures.

NOTE: Before removing and cleaning the unit look for signs of oil and, or gas leakage, also wheel damage which may not be evident after cleaning.

6. Remove the turbocharger and gasket from the exhaust manifold. Cover the opening in the exhaust manifold to prevent the entry of dirt, which could cause damage to the turbine wheel blades after installation and start up.

Disassembly

1. Clean the exterior of the turbocharger using a non caustic cleaning solvent to remove accumulated surface matter before disassembly.

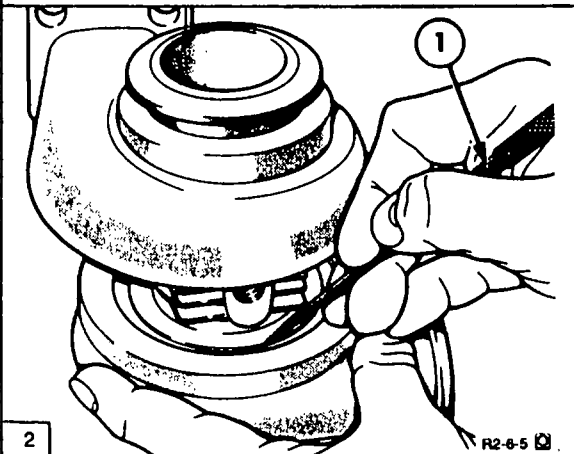

Scribing of Turbocharger Housing

1. Scribe
2. Mark the compressor housing, turbine housing and centre housing with a punch or scribe to facilitate orienting the housings during re-assembly, Figure 2.

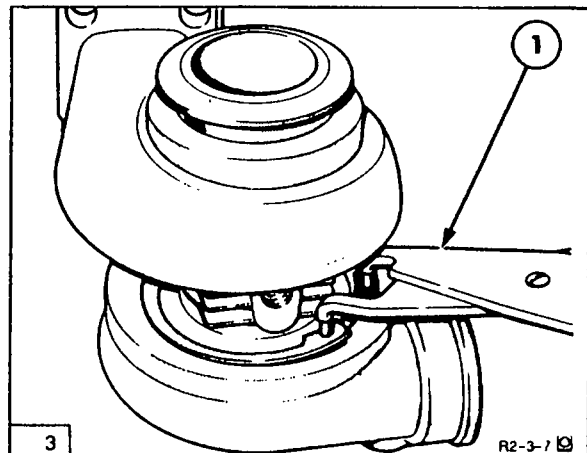

Removal of Compressor Housing

3. Remove compressor housing 'C' clip from centre housing intake side using a suitable tool (1), Figure 3.

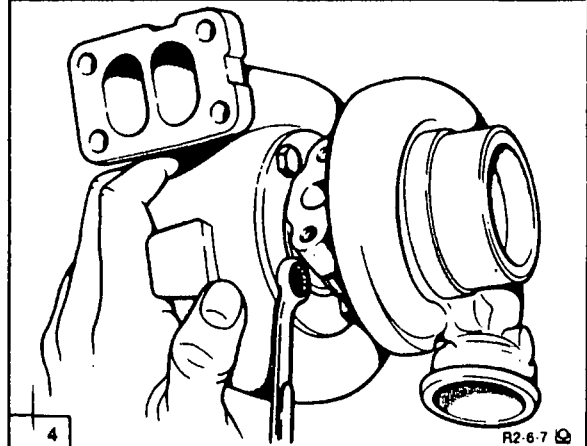

Removal of Turbine Housing

4. Loosen and remove bolts/lockplates from turbine housing exhaust side, Figure 4.

NOTE: Exercise care when removing the compressor housing to avoid damaging the compressor wheel blades. Tap the turbine housing with a soft faced hammer if force is needed to remove.

Cleaning

Before cleaning inspect all parts for burning, rubbing or impact damage that may not be evident after cleaning. Clean all parts in a non caustic solution, using a soft bristle brush, a plastic blade scraper and dry compressed air to remove residue.

DO NOT— use abrasive cleaning methods which might damage or destroy machined surfaces.

DO NOT— immerse Centre Housing and Rotating Assembly (CHRA) in solvent.

DO NOT— blow under compressor wheel with compressed air.

DO NOT— permit wheel/shaft assembly to spin when blowing off solvent and residue.

Inspection

1. Inspect the compressor housing assembly for the following defects:—

Wheel rub damage in the contour area that cannot be polished out with 80 grit silicon carbide abrasive cloth.

Worn, broken or corroded snap ring grooves.

Nicks, dents or distortion that could prevent proper sealing between the compressor housing and the CHRA.

NOTE: Replace the compressor housing if any of the above defects are found.

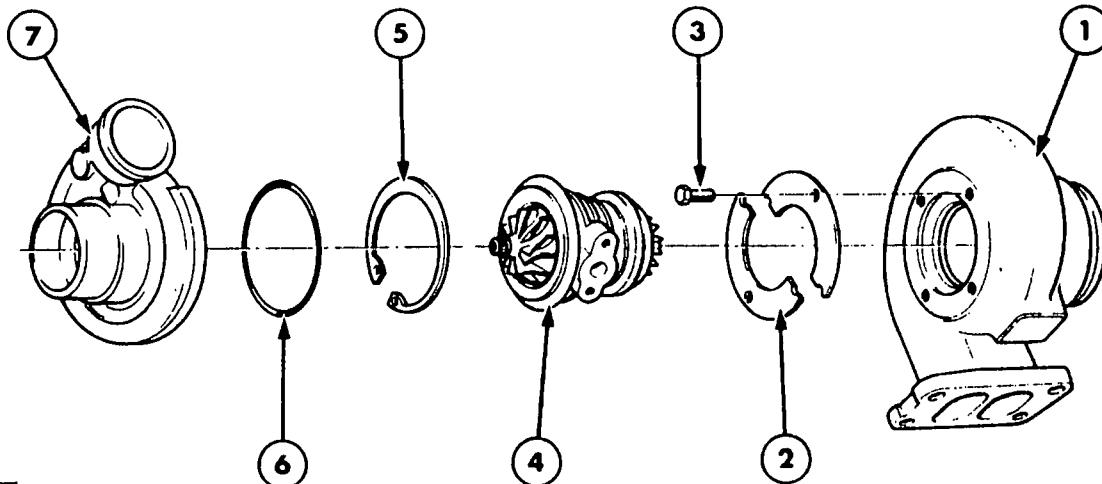

5

R2 7 05A 5G

Explod'ed View of Turbocharger

1. Turbine Housing
2. Retainer Plates
3. Retainer Bolts

4. Turbine CHRA
5. 'C' Clip

6. 'O' Ring
7. Compressor Housing

2. Inspect the turbine housing assembly for the following defects,

Wheel rub damage in the contour area that cannot be polished out with 60 grit silicon carbide abrasive cloth.

Worn, broken, or corroded snap ring grooves (snap ring turbine housing models).

Nicks, dents, or distortion that could prevent proper sealing between the turbine housing and the CHRA.

NOTE: If there is any compressor or turbine wheel blade damage, the CHRA must be replaced. Operating a turbocharger with damaged blades will result in further damage to component parts or the engine.

Blades cannot be straightened in service.

CENTRE HOUSING and ROTATING ASSEMBLY (CHRA)

IMPORTANT: The CHRA as an assembly, has been balanced at the factory, under precision conditions. As such it must not be disassembled in any way. If disassembled the balance will be destroyed, and a new CHRA must be fitted.

Centre Shaft Radial Check

Check the journal bearing radial clearance, whenever there is reason to suspect that the bearings are worn enough to allow either the compressor wheel, or the turbine wheel, to rub on its housing. This may be heard as a high pitched whine.

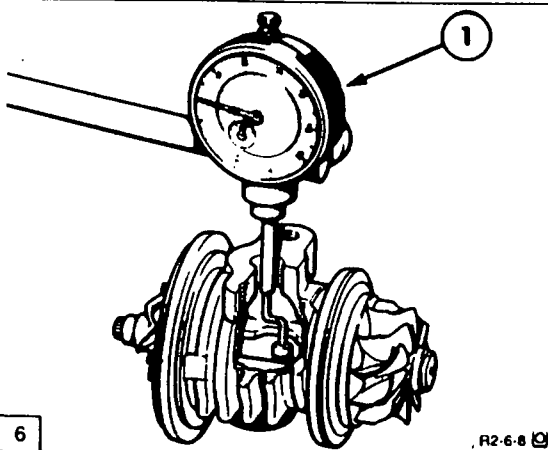

6

R2-6-8

Checking Radial Clearance

1. With the turbocharger removed attach an dial indicator with a dog leg probe (1), Figure 6, to the centre housing. The indicator plunger should extend through the oil outlet port, and contact the shaft of the turbine wheel assembly.

2. Manually apply equal and simultaneous pressure, to the compressor and turbine wheels to move the shaft as far as it will go away from the dial indicator probe.
3. Set the dial indicator to zero.
4. Manually apply equal and simultaneous pressure to the wheels to move the shaft as far as it will go toward the plunger. Make a note of the shaft movement shown on the indicator dial.

NOTE: To make sure the reading indicated is the maximum possible, roll the wheels slightly in both directions while applying pressure.

5. Manually apply equal, and simultaneous pressure to the compressor, and turbine wheels, to move the shaft away from the plunger again. Note that the indicator pointer returns exactly to zero.
6. Repeat the steps 2 to 5 several times, to ensure that maximum radial clearance as indicated by maximum shaft movement, has been measured.
7. If the maximum clearance is less than 0.0022 in (0.056mm) or greater than 0.0050 in (0.127mm) replace the CHRA.

Trouble shoot the engine to find the cause of the bearing failure and correct the problem before resuming operations.

Axle Clearance Check

Check the thrust bearing axial clearance as follows:-

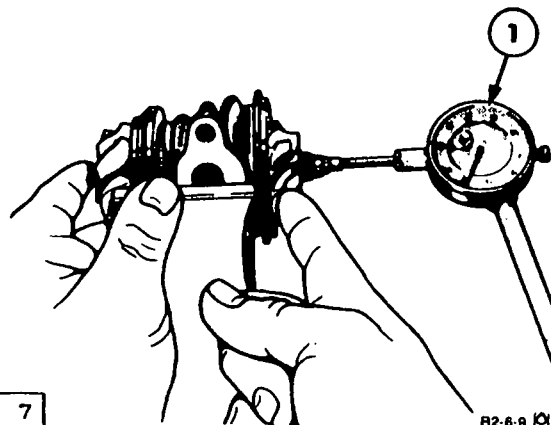

7

R2-6-9

Axial Clearance Check

1. Dial Indicator

1. Place a dial indicator with the probe on the compressor end of the turbocharger shaft assembly, Figure 7.
2. Manually move the compressor/turbine wheel assembly, as far as it will go away from the plunger.
3. Set the dial indicator at zero.
4. Manually move the compressor/turbine wheel assembly as far as it will go toward the dial indicator plunger. Make a note of the shaft movement shown on the indicator dial.
5. Manually move the compressor/turbine wheel assembly as far as it will go away from the plunger. Note that the indicator plunger returns to zero.
6. Repeat steps 2 to 5, several times to make sure that the maximum axial clearance, as indicated by maximum shaft movement, has been measured.
7. If the maximum clearance is less than 0.0010 in (0.0254mm) or greater than 0.0039 in (0.084mm) replace the CHRA

Re-Assembly

1. It is recommended replacing the following with factory authorized parts only, at each overhaul or whenever parts are removed:-

Snap ring, compressor housing retainer

'O' Ring seal, compressor housing

Retainer Plates, turbine housing

Bolts, turbine housing retainers

2. Parts that require changing if faulty or damaged:-

CHRA, turbine assembly

Compressor housing

Turbine housing

3. Inspect all mating surfaces and snap ring groove, to insure that they are free of burrs, foreign matter and corrosion deposits.
4. Transfer scribe marks from old snap rings to new, and coat with a light coating of new engine oil.
5. Install oiled snap ring on compressor end of CHRA, with bevelled face toward the turbine end.

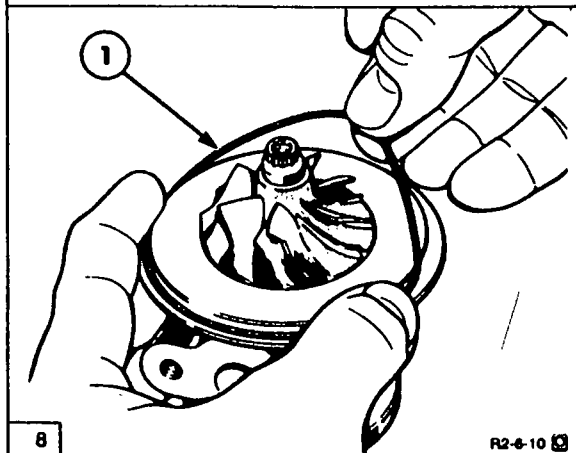

Compressor Assembly

1. 'O' Ring
 6. Install an 'O' ring on the centre housing compressor end flange and place compressor housing assembly in position. Be careful not to damage the compressor wheel blades, Figure 8.
 7. Carefully rotate the compressor housing onto the CHRA to line up scribed marks.
 8. Install the oiled snap ring, lug first, into the compressor housing groove. Be sure that the bevelled side faces the turbine end and the scribe marks are aligned.
 9. Tap the inner circumference or lug ends of the ring with an appropriately sized drift to ensure proper seating.
- NOTE:** When installing a new CHRA or turbine housing, transfer scribed alignment marks from the old to the new parts.
10. Position the turbine housing discharge side down, on a flat, level surface. Place the CHRA turbine wheel end into the housing, use care to avoid damaging the wheel blades. Check visually for proper alignment.

11. Carefully rotate the CHRA in the turbine housing to line up the scribed marks. Recheck for proper alignment and position the locking plates.

12. Coat the bolts in a suitable non-seize compound and tighten to a torque of 15–18 lbf ft (20–25Nm) 2.0–2.5 kgf m.

Installation

1. Prior to installation fill the turbocharger centre housing with new clean oil, and rotate the main shaft to lubricate the bearings.

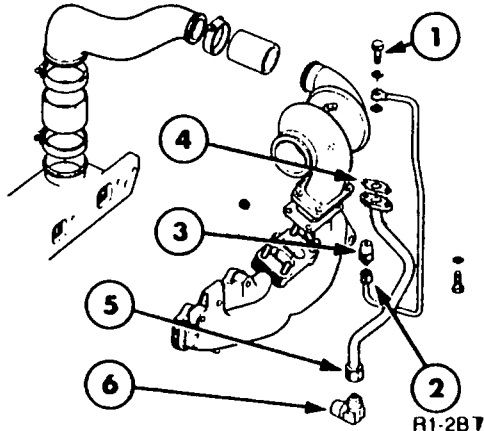

Turbocharger Exploded View

1. Oil Feed Tube to Turbocharger (Banjo Bolt)
 2. Oil Feed Tube to Filter Head Connector
 3. Connector to Filter Head
 4. Oil Return Tube Bolts from Turbocharger to Block
 5. Oil Return Tube to Block Connector
 6. Oil Return Connector to Block
2. Installation of the turbocharger follows the removal procedure in reverse. Install a new manifold gasket, and tighten to, 30–35 lbf ft (41–47Nm) 4.1–4.7 kgf m.
3. Replace the washers and re-connect the oil feed tube banjo bolt (1), Figure 9, and torque to 22–30 lbf ft (30–40Nm) 3.0–4.0 kgf m.
4. The oil feed tube connector (3), Figure 9, if disturbed should be refitted. Apply sealer to connector "See Specifications and torque to, 40–60 lbf ft (54–81Nm) 5.4–8.1 kgf m.

5. Apply sealer "See Specifications", assemble the oil feed tube to the oil filter head connector (2) Figure 9, and tighten to, 13–15 lbf ft (18–20Nm) 1.8–2.0 kgf m

6. Place a suitable receptacle below the oil outlet port and, **WITH THE ELECTRICAL SOLENOID WIRE DISCONNECTED AT THE FUEL INJECTION PUMP**, crank the engine until oil flows from the outlet port.

7. Reconnect the oil outlet tube (4) Figure 9, using a new gasket and tighten the retaining bolts at the turbocharger to 15–18 lbf ft (20–25Nm) 2.0–2.5 kgf m.

8. Tighten the oil return tube to cylinder block connector, (5) Figure 9 to, 45–50 lbf ft (54–81Nm) 5.4–8.1 kgf m.

9. If disturbed Oil return tube connector (6), Figure 9, should have sealer applied "See Specifications" and torque to 20 lbf ft (27Nm) 2.7 kgf m.

10. Reconnect the air inlet, and outlet tubes, with the hose clamps, and torque to 15–20 lbs in (1.7–2.3Nm), Figure 9.

11. Reconnect the fuel injection pump solenoid wire.

12. Check the engine oil level and add oil if required. Idle the engine and check all tubes and gaskets for leaks.

13. Run the engine at rated speed and listen for sounds of metallic contact from the turbocharger. If any noise is apparent, stop the engine immediately and correct the cause.

NOTE: After the unit has obtained operating temperatures, the rotating assembly should coast freely to a stop after the engine is stopped. If the rotating assembly jerks to a sudden stop, the cause should be corrected immediately.

SPECIFICATIONS

GENERAL TORQUES	lbf ft	Nm	kgf m
Turbine Housing Bolts	15-18	20-25	2.0-2.5
Turbocharger to Manifold	30-35	41-47	4.1-4.7
Oil Feed Tube to Turbocharger (Banjo Bolt)	22-30	30-40	3.0-4.0
Oil Feed Tube to Filter Head Connector	13-15	18-20	1.8-2.0
Connector to Filter Head	40-60	54-81	5.4-8.1
Oil Return Tube Bolts from Turbocharger	15-18	20-25	2.0-2.5
Oil Return Tube to Block Connector	45-50	60-70	6.0-7.0
Oil Return Connector to Block	20	27	2.7
Inlet Hose Clamps	(15-20 lbs in)	1.7-2.3	
SEALER			
Type ESE-M4G194-B	Sealer Anaerobic Low Strength		

INJECTORS

FAULT FINDING

PROBLEM	POSSIBLE CAUSES	REMEDY
Nozzle does not buzz whilst injecting	<ol style="list-style-type: none"> 1. Needle valve stuck 2. Leakage 3. Nozzle damaged 	<ol style="list-style-type: none"> 1. Check needle valve is clean and not binding 2. Check valve seat is not leaking 3. Examine nozzle retaining cap for damage
Nozzle leak back	<ol style="list-style-type: none"> 1. Needle valve worn 2. Blocked nozzle assembly 3. Loose nozzle assembly 	<ol style="list-style-type: none"> 1. Renew nozzle assembly 2. Check for carbon or foreign material on faces of nozzle holder. Flush clean or renew 3. Inspect faces and tighten nozzle retaining nut
Nozzle opening pressure incorrect	<ol style="list-style-type: none"> 1. Incorrectly adjusted nozzle retaining nut 2. Damaged nozzle or seized needle valve 3. Blocked nozzle holes 	<ol style="list-style-type: none"> 1. Check adjusting nut for looseness and re-set 2. Renew nozzle assembly 3. Check nozzle holes for carbon or foreign material. Flush clean or replace
Nozzle seat leakage	<ol style="list-style-type: none"> 1. Nozzle incorrectly seated 2. Sticking or binding needle valve 	<ol style="list-style-type: none"> 1. Check for carbon or foreign material on faces of nozzle holder 2. Repair or renew nozzle assembly
Spray pattern distorted	<ol style="list-style-type: none"> 1. Obstructed needle valve 2. Obstructed needle valve holes 3. Damaged nozzle or needle valve 	<ol style="list-style-type: none"> 1. Check for carbon or foreign material on needle valve tip. Flush clean or renew nozzle assembly 2. Check for carbon in needle valve holes. Flush clean or renew nozzle assembly 3. Renew nozzle assembly
Engine emits black smoke	<ol style="list-style-type: none"> 1. Faulty injectors 	<ol style="list-style-type: none"> 1. Overhaul or renew injectors

DESCRIPTION AND OPERATION

The engine injector function is to inject fuel, into a pressurised cylinder in a fully atomised condition. This ensures the fuel burns efficiently.

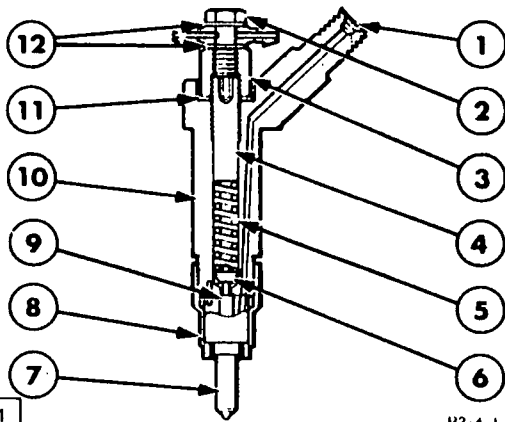

Fuel Injector Assembly

1. Fuel Inlet
2. Leak off Line Bolt
3. Cap Nut
4. Spring Adjusting Screw
5. Spring
6. Spring Seat
7. Nozzle Tip
8. Nozzle Retaining Nut
9. Needle Valve
10. Injector Body
11. Copper Washer
12. Copper Washers

Each injector consists of a nozzle assembly, containing a needle valve and a nozzle holder assembly housing the injector needle valve regulating spring, Figure 1.

Fuel from the fuel injection pump enters the injector fuel inlet and passes down through a drilling in the nozzle holder and body to the needle valve seat.

The fuel pressurised by the injection pump, lifts the needle valve off the seat against the action of a spring. The fuel is then forced in an atomised state, through the four holes in the nozzle tip. When the pressure from the injection pump drops, the needle valve snaps back onto the seat under pressure from the spring.

To provide lubrication of the injector a small amount of fuel is permitted to leak up between the needle valve and the nozzle body. The excess fuel rises to the top of the injector and returns to the fuel tank via an injector leak off line.

OVERHAUL

Removal

1. Slacken the high pressure fuel pipe gland nuts, at the injection pump.
2. Clean the area around the injectors.
3. Remove the banjo bolts, and disconnect the fuel leak off lines, discarding the two copper washers from each bolt, Figure 2.
4. Unscrew the gland nuts and disconnect the high pressure pipes from the injectors, Figure 2.

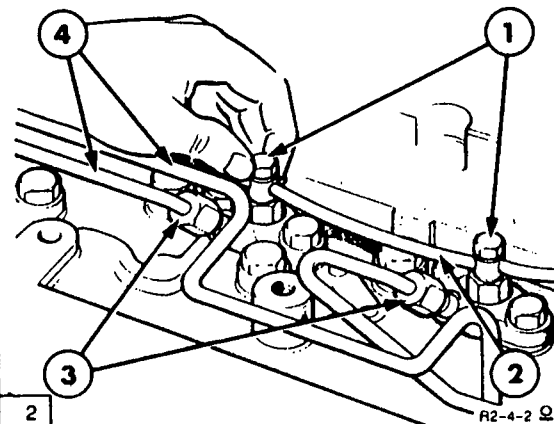

Disconnecting Injector Pipes

1. Banjo Bolts
2. Leak-Off Pipe
3. High Pressure Fuel Pipe Gland Nuts
4. High Pressure Fuel Pipes

5. Unscrew and remove the two retaining bolts from each injector and withdraw the injector from the cylinder head, Figure 3. Ensure no dirt falls into the injector seat.

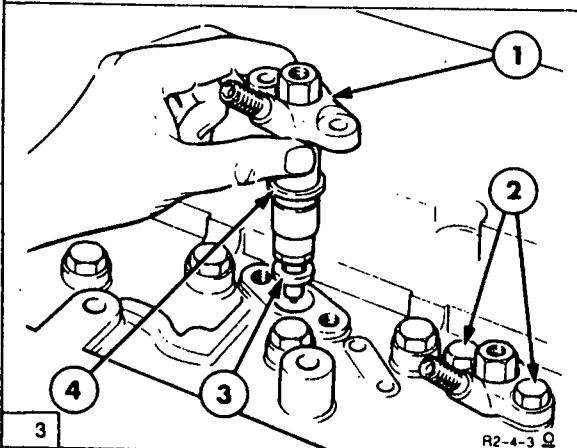

Removing Injector

1. Injector
2. Retaining Bolts
3. Copper Sealing Washer
4. Cork Dust Washer

6. Discard the cork washer and the copper sealing washer, Figure 3.

NOTE: The copper sealing washer may have to be extracted from the bore in the cylinder head.

7. If a replacement set of injectors is not immediately available, cover the ends of the pipes and the cylinder head apertures to prevent entry of dirt or foreign material.
8. To establish if overhaul or replacement is necessary, test the injectors according to the following procedure. Before testing fit a protective cap to the inlet union and clean the outside of the injectors with a soft wire brush and a carbon solvent.

Testing

WARNING: The spray from an injector tester can pierce human skin, with fatal results. When an injector is spraying, the nozzle holder should be turned away from the operator and any other persons.

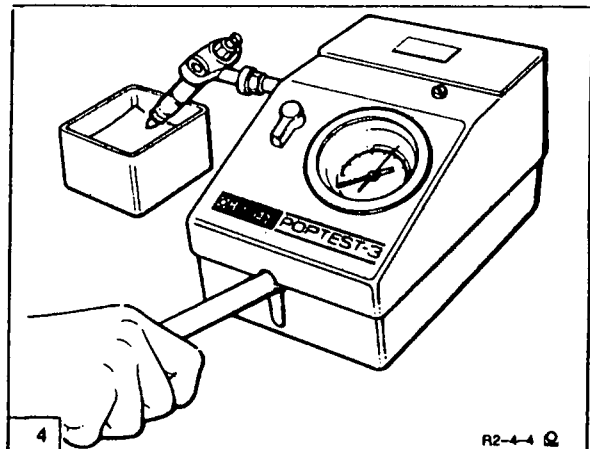

Nozzle Opening Pressure Test

During the NOZZLE OPENING PRESSURE AND SPRAY PATTERN TESTS, collect the spray in a container partly filled with rags to absorb the spray, Figure 4.

When conducting the NOZZLE SEAT LEAKAGE TEST, release the injector tester pump pressure before touching the nozzle tip with a sheet of blotting paper.

WARNING: The spray is inflammable. Ensure no naked lights are in the area of the tester and do not generate excessive vapour.

1. Fill the injector tester with a calibrating type fuel oil and leave the filler cap loose to prevent a vacuum forming during testing.
2. Prime the tester until oil is emitted from the tester line, then connect the injector.
3. Ensure the knob on the right hand side of the tester is screwed in to prevent the gauge being over pressurised if the injector nozzle is blocked.
4. Pump the tester and check the nozzle is free to open. Open the pressure gauge valve and commence injector testing. If the nozzle is blocked or the needle jammed commence the disassembly procedure.

5. **NOZZLE OPENING PRESSURE:** Pump the injector tester and observe the pressure at which the needle valve lifts and fuel is ejected from the nozzle tip. Opening pressure should be: 193 atm (190 bar).
6. **SPRAY PATTERN:** Pump the tester rapidly and observe the spray pattern from the four holes. Each spray must be similar and spaced at approximate intervals of 110°, 90°, and 70°, respectively. The spray should be well atomised and spread into a 3 in (76mm) diameter cone, 0.38 in (9.5mm) from the injector nozzle.

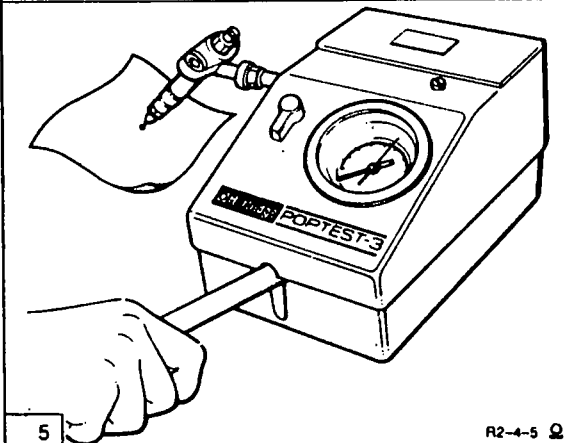

R2-4-5 Ω

Nozzle Seat Leakage Test

7. **NOZZLE SEAT LEAKAGE:** Wipe the nozzle tip dry and apply a pressure of 150 lbf in² (10 bar) 10 kgf cm² below the opening pressure to the injector. Hold the pressure for six seconds then touch the nozzle tip with a sheet of blotting paper, Figure 5. The fuel stain should not exceed 0.5 in (12.7mm) diameter.
8. **NOZZLE LEAK-BACK TEST:** Apply approximately 2300 lbf in² (158bar) 62 kgf cm² pressure to the injector and measure the time taken for the pressure to fall from 2200 lbf in² (152bar) 155 kgf cm² to 1500 lbf in² (103bar) 105 kgf cm². If this time is less than 5 seconds, the needle is loose or there is dirt between the nozzle and injector body faces.
9. If the injector passes the tests, re-install in the engine. If the injector fails any of the tests, proceed to disassembly.

Disassembly

- Place the injector in a holding fixture. Do not clamp the injector body in a vice.
- Remove the cap nut and spring adjusting nut, Figure 6. Remove the injector spring washer and spindle.

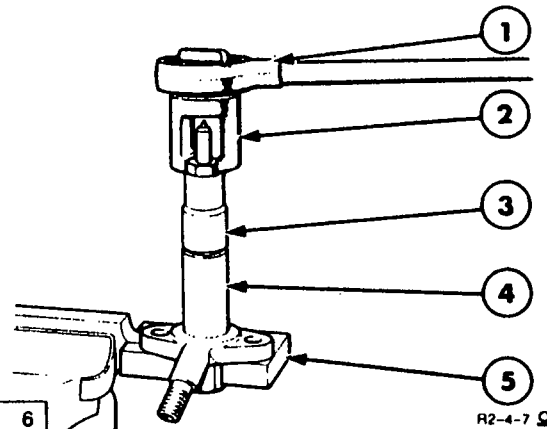

Nozzle Retaining Nut Removal

- Wrench
 - Nozzle Nut Socket, Tool No CT9009 or 8126
 - Nozzle Retaining Nut
 - Injector
 - Holding Fixture
3. Use Socket, Tool No. CT9009 or 8126, to remove the nozzle retaining nut, Figure 6. Lift off the nozzle and needle valve assembly then withdraw the needle valve.

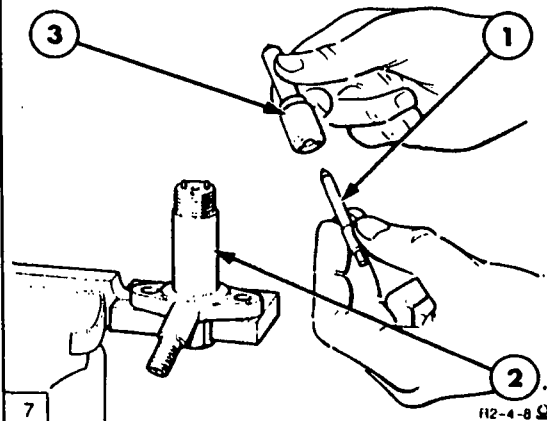

Needle Valve Removal

- Needle Valve
 - Nozzle Holder
 - Nozzle
4. Place all components in clean fuel oil.

NOTE: As the nozzles and needle valves are a lapped fit, they are not interchangeable.

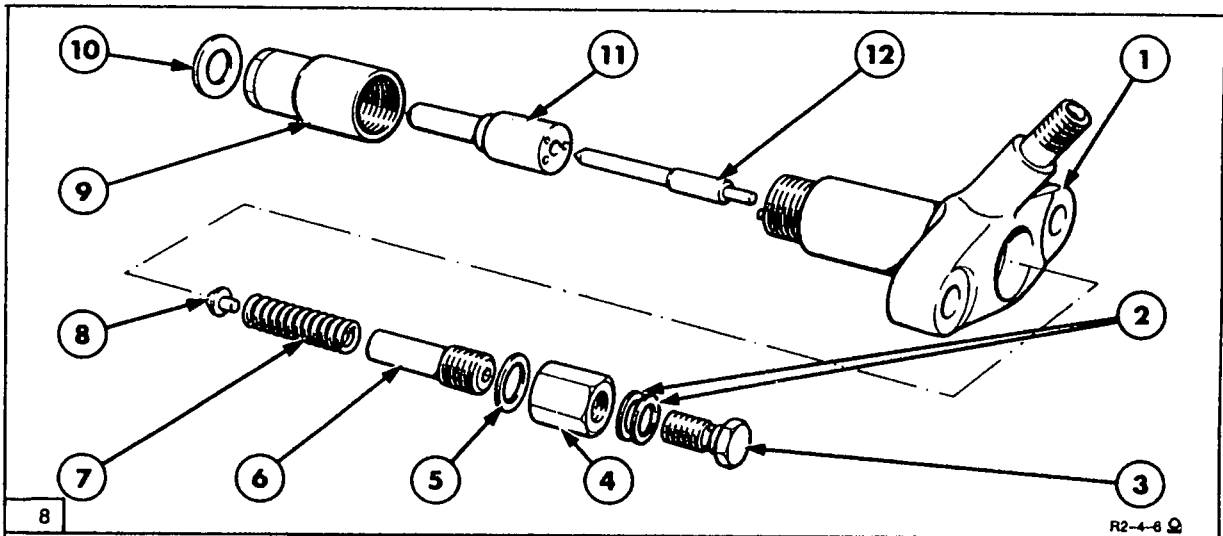

Injector Components

- | | | |
|--------------------------|---------------------------|-------------------|
| 1. Injector Body | 5. Copper Washer | 9. Nozzle Body |
| 2. Leak-Off Line Washers | 6. Spring Adjusting Screw | 10. Copper Washer |
| 3. Leak-Off Line Bolt | 7. Spring | 11. Nozzle Head |
| 4. Cap Nut | 8. Spring Seat | 12. Needle Valve |

Inspection and Repair

1. Clean the needle valve and nozzle by soaking in a carbon solvent and brushing with a soft wire brush. To prevent corrosion rinse the nozzle and valve in clean fuel oil.
2. Use the tools included in the injector nozzle cleaning kit, Tool No. FT 9101 or 1720 to clean the nozzle as follows:-

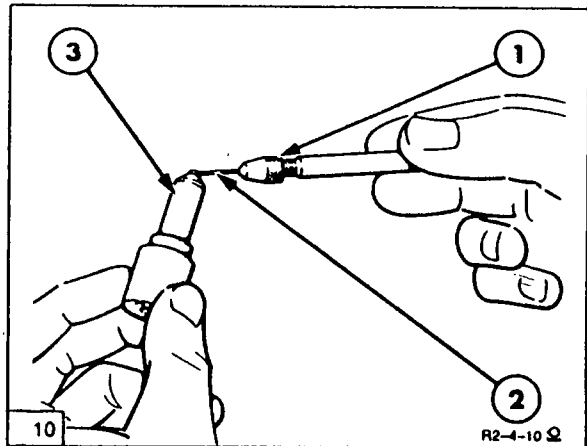

Cleaning Nozzle Spray Holes

1. Pin Vice
2. Nozzle Cleaning Wire
3. Nozzle

4. Clean the spray holes with the nozzle cleaning wire held in a pin vice, Figure 10.

5. Clean the valve seat with the valve seat scraper.

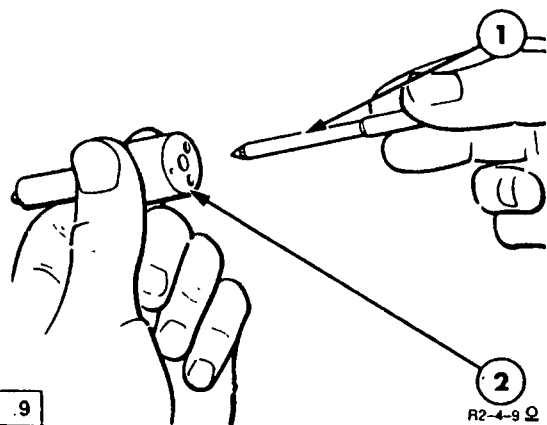

Clean Nozzle Pressure Chamber

1. Pressure Chamber Drill
 2. Nozzle
3. Clean the nozzle pressure chamber using the pressure chamber drill, Figure 9.

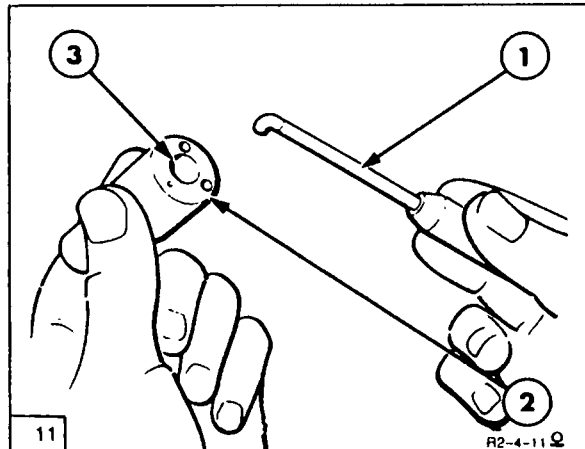

Cleaning Nozzle Annular Groove

1. Carbon Scraper
2. Nozzle
3. Annular Groove

6. Clean the annular groove in the top of the nozzle and the groove in the nozzle pressure chamber, using the pressure chamber scraper, Figure 11.

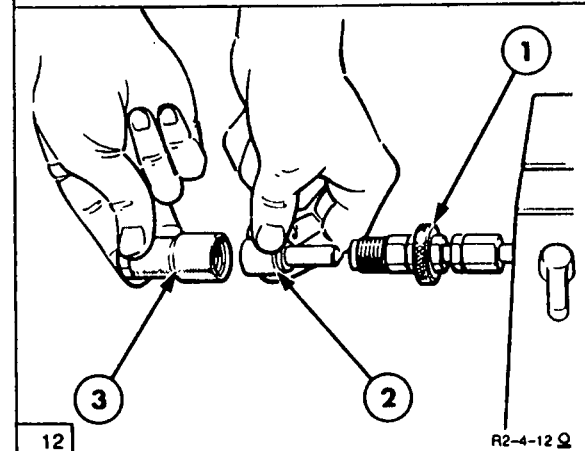

Reverse Flushing the Nozzle

1. Reverse Flush Adapter, Tool No. CT9024
2. Nozzle
3. Nozzle Retaining Nut

7. Use a reverse flush nozzle adaptor, Tool No CT9024 or 8124, on the injector tester, Figure 12. Reverse flush the nozzle to remove the carbon loosened during steps 1 to 4.

8. After flushing the nozzle, polish the valve seat by placing a very small amount of tallow on the end of a polishing stick and rotate in the nozzle.

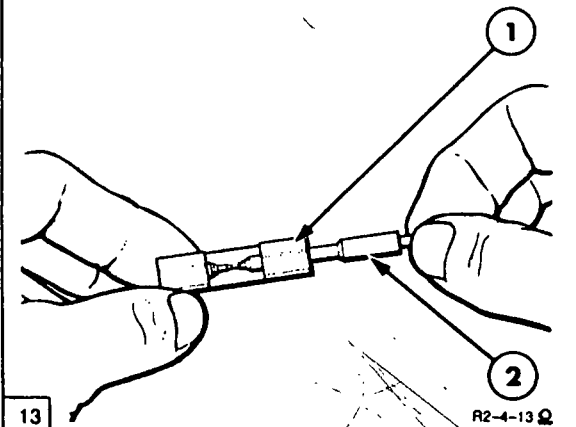

Cleaning Needle Valve Tip

1. Needle Valve Scraper
2. Needle Valve

9. Clean the top of the needle valve using a needle valve scraper, Figure 13.

10. If the nozzle leak-back test time was less than five seconds or the valve sticks, the valve and nozzle should be lapped together by placing the tip end of the nozzle in a drill chuck having a speed of 450 revs min or less. Spread a small amount of tallow over the valve surface. Insert the valve into the rotating nozzle, centralise and apply slight pressure as the chuck turns.

NOTE: Do not lap the valve for more than five seconds at a time. Allow the parts to cool between lapping.

11. Prior to re-assembly, the lift of the injector needle must be rechecked with a dial indicator. Maximum allowable lift is 0.015 (0.4mm).

Re-Assembly

1. Clean all parts in fuel oil prior to re-assembly. Rinse all parts in clean fuel oil and assemble the components whilst still wet.

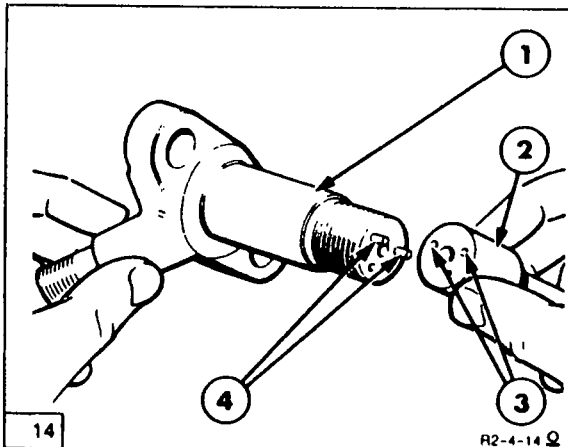

Assembling the Injector

1. Nozzle Holder
 2. Nozzle
 3. Dowel Pin Holes
 4. Locating Holes
2. Position the nozzle and valve assembly onto the nozzle holder and ensure the dowel pin holes are correctly located, Figure 14. Hold the injector body in the fixture, install the retaining nut with a new washer and tighten to: 34 lbf ft (46Nm) 4.6 kgf m.
 3. Install the spindle, spring disc, spring and adjusting nut. Turn the nut until spring pressure is felt.

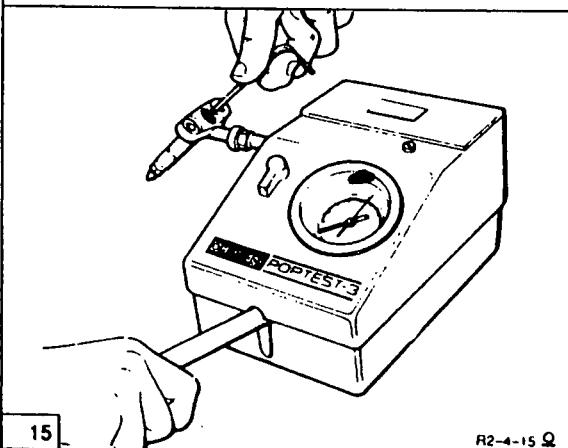

Nozzle Opening Pressure Adjustment

4. To set the nozzle opening pressure, connect the injector to the injector tester. Tighten the adjusting nut, Figure 15, until the specified opening pressure is achieved.
5. Install the cap nut with a new copper washer and retest the injector. If the injector fails any of the tests after cleaning, renew the nozzle and valve.

Installation

1. Remove any blanking plugs from cylinder head apertures and pipe ends.
2. Insert the new, replacement injector in the cylinder head, having fitted a new cork dust washer and a new copper sealing washer.
3. Secure each injector with the two retaining bolts and tighten to, 15–18 lbf ft (20–24Nm) 2.0–2.4 kgf m.
4. Reconnect the leak-off pipe using new washers either side of the banjo fittings and tighten banjo bolts to, 5–10 lbf ft (7–14Nm) 0.7–1.4 kgf m.
5. Reconnect high pressure fuel pipes to injectors, Figure 16. Tighten the gland nuts to: 16–20 lbf ft (22–27Nm) 2.2–2.7 kgf m.

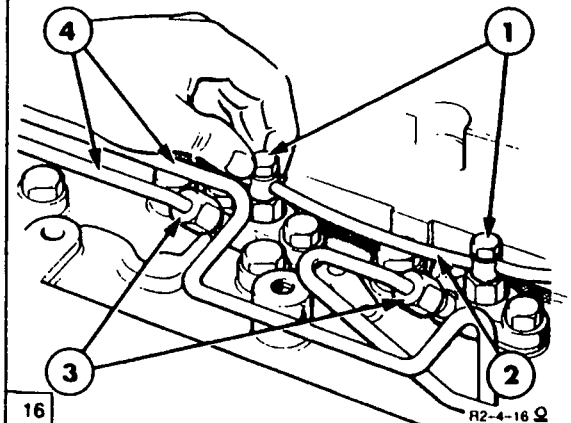

Connecting Injector Pipes

1. Banjo Bolts
2. Leak-Off Pipe
3. High Pressure Fuel Pipe Gland Nuts
4. High Pressure Fuel Pipes
6. Tighten high pressure fuel pipe gland nuts at the injection pump to, 16–20 lbf ft (22–27Nm) 2.2–2.7kgf m.
7. Bleed the fuel system as detailed in Chapter 1.
8. If the injectors are to be stored before installation, clean in calibrating oil. Storage for longer than 6 months may result in the necessity of disassembling and cleaning the injectors before installation.

SPECIFICATIONS AND TOOLS

GENERAL TORQUES

	lbf/ft	Nm	kgf/m
Injector Nozzle Retaining Nut	34	46	4.6
Injector Retaining Bolts	17	22	2.2
Injector Leak-Off Line Banjo Bolts	8	12	1.2
High Pressure Gland Nuts, at Injector and Fuel Injection Pump -	18	24	2.4

INJECTOR NOZZLE OPENING (POP OFF) PRESSURE

ENGINES	7450I10	7450SI10	7675SI10	7675I10
Bar	240-248 (Reset at 225)			290-299 (Reset at 275)
lbs in ²	3480-3590 (Reset at 3260)			4230-4350 (Reset at 4000)

INJECTOR CHANGE INTERVAL

1200 Hours

DESCRIPTION

V L CHURCHILL

NUDAY TOOLS

FNH

Injector Nozzle Nut Socket	CT9009	8126	01588
Nozzle Reverse Flush Adaptor	CT9024	8124	01727/8
Injector Cleaning Kit	DX730/FT9101	1720	01720
Kit consists of- Nozzle Cleaning Wires, Pressure Chamber Drills, Pressure Chamber Scraper Valve Seat Scraper, Brass Wire Brush, Pin Vice			
Tallow		Obtain Locally	
Polishing Sticks		Obtain Locally	

FUEL INJECTION PUMP-DPS FAULT FINDING

PROBLEM	POSSIBLE CAUSES	REMEDY
Engine starts and stops	<ol style="list-style-type: none"> 1. Fuel starvation 2. Contaminated fuel 3. Restricted air intake 4. Engine overheating 5. Air in system 	<ol style="list-style-type: none"> 1. Check and flush clean restricted fuel lines or fuel filters 2. Check for water in the fuel 3. Check for restrictions in the air intake 4. Check cooling system 5. Check for air leaks on the suction side of the system
Fuel not reaching injection pump	<ol style="list-style-type: none"> 1. Fuel shut-off valve closed 2. Restricted fuel filters 3. Air in system 4. Fuel leakage 	<ol style="list-style-type: none"> 1. Check the fuel shut-off valve at the fuel tank is in the "ON" position 2. Check and flush the fuel filters clean 3. Bleed the fuel filters 4. Check the fuel lines and connectors for damage
Fuel reaching nozzles but engine will not start	<ol style="list-style-type: none"> 1. Low cranking speed 2. Incorrect throttle adjustment 3. Incorrect pump timing 4. Fuel leakage 5. Faulty injectors 6. Low compression 	<ol style="list-style-type: none"> 1. Check the cranking speed 2. Check the throttle control rod travel 3. Check the pump timing 4. Check the fuel lines and connectors for leakage 5. See injector trouble shooting 6. Check the engine compression
Engine hard to start	<ol style="list-style-type: none"> 1. Low cranking speed 2. Incorrect pump timing 3. Restricted fuel filters 4. Contaminated fuel 5. Low compression 6. Air in system 	<ol style="list-style-type: none"> 1. Check the cranking speed 2. Check the pump timing 3. Check and flush the fuel filters clean 4. Check for water in the fuel 5. Check the engine compression 6. Check for air leaks on the suction side of the system

PROBLEM	POSSIBLE CAUSES	REMEDY
Difficulty in setting delivery by maximum speed stop screw	<ol style="list-style-type: none"> 1. Governor spring damaged or of wrong type 2. Governor link setting incorrect 3. Governor spring linkage incorrectly coupled 4. Sticking metering valve 5. Sticking governor thrust sleeve 	<ol style="list-style-type: none"> 1. Renew spring 2. Set correctly 3. Assemble correctly 4. Repair or renew valve 5. Repair or renew sleeve
Erratic engine operation (surge, misfiring, poor governor regulation)	<ol style="list-style-type: none"> 1. Fuel leakage 2. Fuel starvation 3. Incorrect pump timing 4. Contaminated fuel 5. Air in system 6. Faulty or sticking injector nozzles 7. Incorrect engine timing 	<ol style="list-style-type: none"> 1. Check the injector lines and connectors for leakage 2. Check and flush clean restricted fuel lines or filters 3. Check the pump timing 4. Check for water in the fuel 5. Bleed the fuel system 6. See injector trouble shooting 7. Check for faulty engine valves
Engine emits black smoke	<ol style="list-style-type: none"> 1. Restricted air intake 2. Engine overheating 3. Incorrect timing 4. Faulty injectors 5. Low compression 6. Incorrect engine timing 	<ol style="list-style-type: none"> 1. Check for restricted air intake 2. Check cooling system 3. Check the pump timing 4. See injector trouble shooting 5. Check the engine compression 6. Check the engine valves

PROBLEM	POSSIBLE CAUSES	REMEDY
Engine does not develop full power or speed	<ol style="list-style-type: none"> 1. Incorrect throttle adjustment 2. Incorrect maximum no-load speed 3. Fuel starvation 4. Air in system 5. Incorrect timing 6. Low compression 7. Incorrect engine timing 	<ol style="list-style-type: none"> 1. Check for insufficient throttle control movement 2. Check maximum no-load speed adjustment 3. Check and flush clean restricted fuel lines and filters 4. Check for air leaks on the suction side of the system 5. Check pump timing 6. Check engine compression 7. Check for improper valve adjustment or faulty valves
Shut-Off not working	<ol style="list-style-type: none"> 1. Sticking Solenoid valve plunger 2. Permanent electrical feed to solenoid valve 	<ol style="list-style-type: none"> 1. Repair or renew valve 2. Inspect or repair electrical circuit
Low transfer pressure	<ol style="list-style-type: none"> 1. Regulating valve inner seal damaged 2. Regulating spring or piston missing 3. Incorrect regulating spring 4. Worn or damaged transfer pump blades 5. Faulty transfer pump seal 6. Loose or incorrectly tightened end plate 7. Faulty washers on head locking and head locating screws 8. Damaged seals on head locating fitting 	<ol style="list-style-type: none"> 1. Renew seal 2. Renew spring or piston 3. Install correct spring 4. Renew damaged unit 5. Renew seal 6. Tighten or renew damaged unit 7. Renew washers 8. Renew seals

PROBLEM	POSSIBLE CAUSES	REMEDY
High transfer pressure	<ol style="list-style-type: none"> 1. Sticking regulator piston 2. Incorrect regulating spring – too strong 3. Test bench operating on pressure feed 4. Regulating spring guide installed upside down 5. Incorrect regulating spring guide 6. Regulating sleeve installed upside down 	<ol style="list-style-type: none"> 1. Repair or renew piston 2. Install correct spring 3. Check maximum pressure feed 4. Install correctly 5. Install correct guide 6. Install correctly
Low and fluctuating transfer pressure	<ol style="list-style-type: none"> 1. Regulating sleeve inner gasket faulty 2. One transfer pump blade chipped 	<ol style="list-style-type: none"> 1. Renew gasket 2. Renew unit
Low advance reading	<ol style="list-style-type: none"> 1. Low transfer pressure 2. Too many shims installed 3. Spring too stiff, incorrect type installed 4. Sticking advance piston 5. Sticking cam ring 6. Excessive clearance between advance piston and housing 7. Leaking advance gasket 	<ol style="list-style-type: none"> 1. Inspect and repair transfer pump 2. Shim correctly 3. Install correct spring 4. Repair or renew piston 5. Repair or renew cam ring 6. Install new components 7. Renew gasket
High advance reading	<ol style="list-style-type: none"> 1. High transfer pressure 2. Insufficient shims 3. Incorrect spring, too weak 	<ol style="list-style-type: none"> 1. Inspect transfer pump for restriction on outlet side 2. Shim correctly 3. Renew spring
Low delivery during fuel delivery check, at maximum speed	<ol style="list-style-type: none"> 1. Maximum speed stop screw incorrectly adjusted 2. Faulty or incorrect governor spring 3. Governor spring linkage coupled to wrong holes 4. Sticking metering valve 	<ol style="list-style-type: none"> 1. Adjust correctly 2. Renew spring 3. Correct linkage coupling 4. Repair or renew valve

PROBLEM	POSSIBLE CAUSES	REMEDY
Incorrect maximum fuel delivery	<ol style="list-style-type: none"> 1. Throttle not fully open 2. Incorrect maximum fuel setting 3. Sticking metering valve 4. Air in system 5. Sticking plungers or roller shoes 6. Scroll plate link plate sticking or weak spring 7. Incorrect transfer pressure 8. Shut off mechanism fouling metering valve 9. Governor link adjustment incorrect 10. Governor spring linkage incorrectly assembled 11. Cam ring or scroll plates reversed 	<ol style="list-style-type: none"> 1. Inspect and renew throttle 2. Check and adjust maximum fuel setting 3. Repair or renew valve 4. Purge and eliminate source of air 5. Repair or renew faulty items 6. Check and repair link plate and return spring 7. Inspect and repair transfer pump 8. Repair or renew mechanism 9. Adjust correctly 10. Assemble correctly 11. Install correctly
Low fuel delivery during excess fuel delivery check	<ol style="list-style-type: none"> 1. Low transfer pressure 2. Throttle not fully open 3. Sticking metering valve 4. Sticking plungers or roller shoes 5. Sticking scroll plate link plate or weak spring 6. Plungers scored 7. Outlet ports scored 8. Excessive clearance, rotor to hydraulic head 9. Air in system 10. Scored metering valve 	<ol style="list-style-type: none"> 1. Inspect and repair transfer pump 2. Inspect and repair throttle 3. Repair or renew valve 4. Repair or renew faulty items 5. Check and repair link plate or renew spring 6. Install new plungers 7. Install new unit 8. Install new head and rotor assembly 9. Purge and eliminate source of air 10. Install new valve

FUEL INJECTION PUMP-OVERHAUL

Except in the case of complete overhaul full dismantling is not always necessary. When a pump requires attention, the recommended practice is to set it up on a test machine and check to locate specific faults or adjustments.

Repairs or adjustments can be undertaken on the basis of the test results.

Dismantling, assembly, testing and adjustment of the DPS pump must be carried out by trained personnel, using specialised tools and test apparatus. The service tools listed in Special Tools, must be used to obtain the closest possible approach to factory standards.

Conditions of scrupulous cleanliness must be observed in workshops where pump overhaul is carried out. The following equipment must be available in the workshop when fuel injection equipment is to be serviced:-

1. A bench covered with sheet metal or linoleum, which should be kept for injection equipment only.
2. A divided storage tray of fire retardant material.
3. A vice with soft metal or fibre jaws.
4. A fire proof tank containing clean test oil for large components and a small bath with a lid, containing clean test oil which should be kept only for pump plungers and small components.
5. A complete set of Special Tools
6. Non-Fluffy cloths must be used for drying of hands. Under no circumstances use cotton waste.

TYPEPLATE

The number stamped on the typeplate attached to the pump housing, identifies the type and model of the pump. Pumps that are of identical build but with modified settings for different applications are further identified by the setting code stamped beneath the ordering number.

Should the typeplate be obscured by paint care must be taken to ensure that the type details are not defaced when removing the paint.

Overhaul Procedure

If any part in a mated assembly is damaged or worn, the complete assembly must be rejected. Any component showing signs of fretting, wear, damage, corrosion, cracks or distortion must be discarded.

All 'O' rings, gaskets, tab washers, locking and sealing devices must be discarded and new ones fitted.

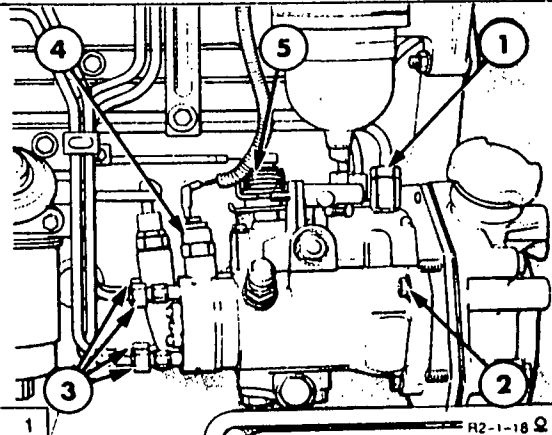
Removal

Fuel Injection Pump Removal

1. Fuel Return Line
 2. Pump Retaining Bolts
 3. Injector Lines
 4. Fuel Shut-off Solenoid
 5. Throttle Linkage
1. Clean all dirt from the injection pump and the surrounding parts.
 2. Turn the fuel shut-off valve to the "OFF" position.
 4. Disconnect and remove all fuel lines from the injection pump, Figure 1 and cap all openings to prevent entry of dirt.

6. If the pump is not to be internally timed then prior to removal, note the setting of the pump relative to the zero degree mark on the rear of the engine front plate. Mark the plate with a centre punch to align with the pump flange scribed line.
7. Remove the engine timing cover. Withdraw the drive gear retaining nut from the injection pump driveshaft.
8. Fabricate a puller as outlined in Special Tools. Install the pulley to the drive gear using three bolts and remove the gear. (see page 105)
9. Withdraw the pump mounting bolts then remove the pump from the engine front cover plate. Cap all openings to prevent entry of dirt.

Disassembly

Before commencing disassembly remove the surface grime from the exterior of the pump by using a suitable proprietary fluid as a cleansing agent.

Turn the pump on its side drain plug uppermost. Remove the drain plug from the pump housing, detach the Dowty washer and discard. Invert the housing and drain the pump oil into a suitable receptacle.

PRESSURISING VALVE

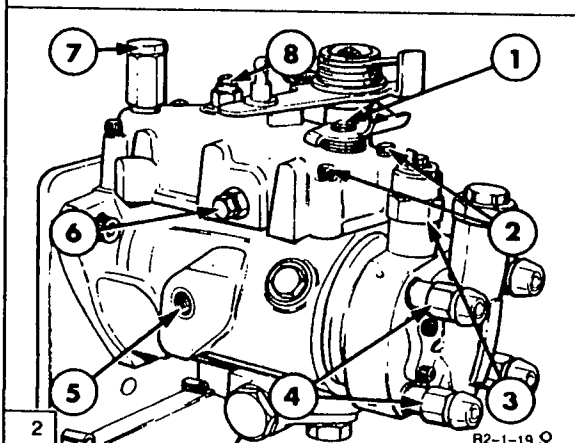

Governor Control Cover Components

1. Fuel Shut-Off Setbolt
2. Governor Control Cover Screws
3. Solenoid Shut-Off Valve
4. Delivery Valves
5. Drain Plug
6. Maximum Fuel Adjustment Screw
7. Pressurising Valve
8. Vent Screw

1. Unscrew and remove the pressurising valve holder (7), Figure 2, from the governor control cover. Remove and discard the duty washer from the valve.

Solenoid Shut-Off Valve

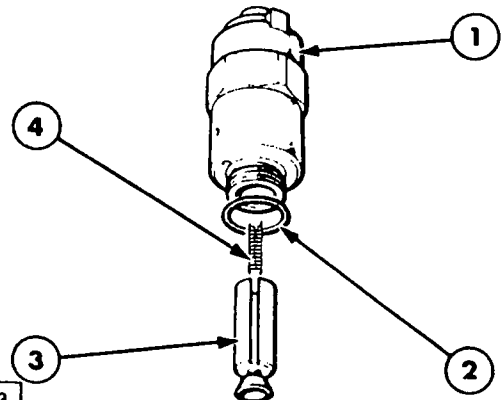

Solenoid Shut-Off Valve Components

- | | |
|--------------------|-----------|
| 1. Solenoid Valve | 3. Piston |
| 2. Rubber 'O' Ring | 4. Spring |

1. Remove the solenoid from the hydraulic head complete with plunger and spring, Figure 3. Discard the rubber 'O' ring from the solenoid.

NOTE: The solenoid plunger and body are a matched assembly and should not be separated.

Throttle Lever Assembly

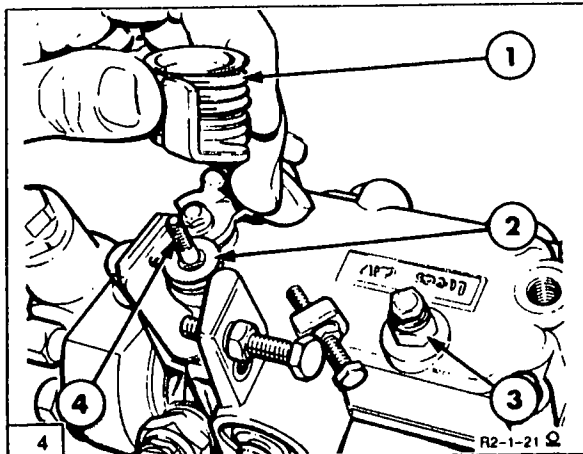

Throttle Lever Disassembly

1. Throttle Lever Assembly
2. Cap Washer
3. Vent screw and Thermostart Connection
4. Throttle Lever Shaft

1. Unscrew and remove the self locking nut from the throttle shaft. Remove the washer from inside the spring guide.
2. Remove the throttle lever assembly from the shaft complete with the break back spring and spring guides, Figure 4. Remove the cap and washer from the lever shaft.
3. Loosen the set bolt in the manual fuel shut-off lever, Figure 2 and remove complete with washers. Lift the lever complete with spring from the governor control cover and remove the cap washer from the lever shaft.

Vent Screw

1. Loosen the vent screw, Figure 4 and unscrew and remove from the governor control cover. Discard the copper sealing washer.

Governor Control Cover

1. Loosen and remove the maximum fuel screw locknut (6), Figure 2. Unscrew the maximum fuel adjustment screw from the governor control cover and discard the rubber sealing washer.

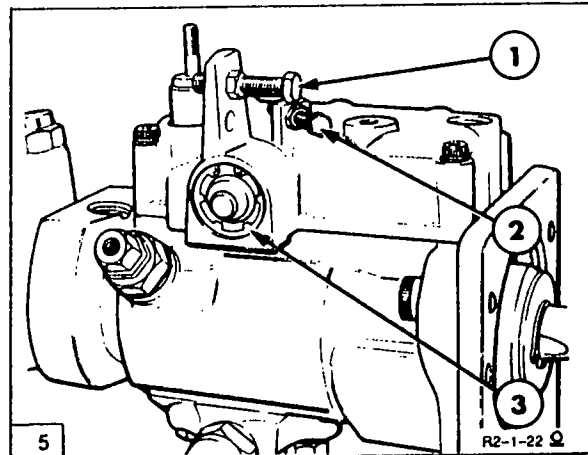

Excess Fuel Device

1. Maximum No-Load Speed Screw
2. Slow Idle Screw
3. Excess Fuel Device Snap Ring

2. Using suitable snap-ring pliers remove the snap-ring from the excess fuel supply device, Figure 5, remove plug and discard the rubber 'O' Ring.

NOTE: Do not remove the piston from the excess fuel device at this stage as it is used to disengage the excess fuel shaft when removing the governor control cover.

3. Using a suitable allen wrench remove the four allen screws (2) together with the washers from the governor control cover, Figure 2.

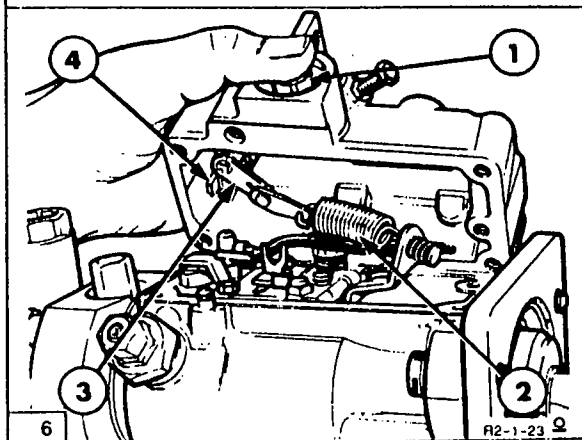

Governor Control Cover Removal

1. Excess Fuel Device Piston
2. Governor Control Spring
3. Throttle Shaft
4. Fuel Shut-Off Shaft

4. Lift the governor control cover away from the pump housing while at the same time, depressing the excess fuel piston to detach the excess fuel shaft from the scroll plate link plate, Figure 6. Once the excess fuel device is detached, push down on the threaded end of the throttle shaft assembly. The shaft must be pressed through the cover to remain connected to the governor spring. Push out the fuel shut-off shaft from the governor control cover. Remove and discard the rubber 'O' rings from the shaft, and remove and discard the governor control cover gasket.

5. Remove the excess fuel piston from the governor control housing. Disconnect and remove the governor spring from the throttle shaft and governor arm. Remove and discard the rubber 'O' rings from the shaft.

GOVERNOR ARM AND CONTROL BRACKET ASSEMBLY

1. From the control bracket remove the scroll link plate spring retainer, spring, sleeve, washers and spacer, Figure 7. Discard the spring retainer, unlock the tab washers, unscrew and remove the three retaining bolts.

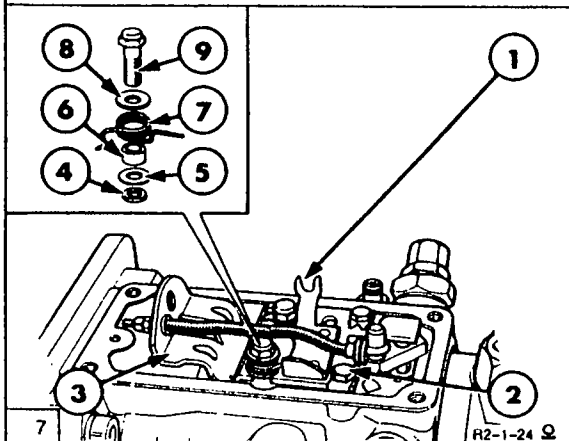

Link Plate Retaining Bolts

- | | |
|-------------------------------|-----------|
| 1. Link Plate Retaining Bolts | 6. Spacer |
| 2. Link Plate Spring Retainer | 7. Spring |
| 3. Link Plate | 8. Washer |
| 4. Small Washer | 9. Bolt |
| 5. Washer | |

2. Lift off as an assembly the control bracket complete with governor arm, metering valve and spring linkage assembly, Figure 8. Detach the metering valve from the linkage hook and immerse in clean test oil.

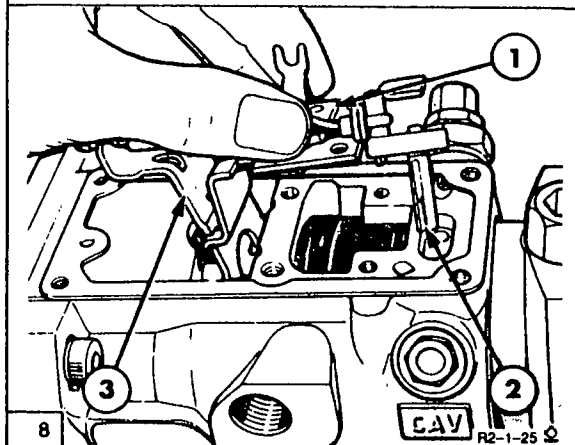

Control Bracket and Governor Arm

- | | |
|-------------------|-----------------|
| 1. Link Plate | 3. Governor Arm |
| 2. Metering Valve | |

3. Disengage the control bracket from the governor arm and dismantle the governor spring linkage from the governor arm in the following sequence, Figure 8.

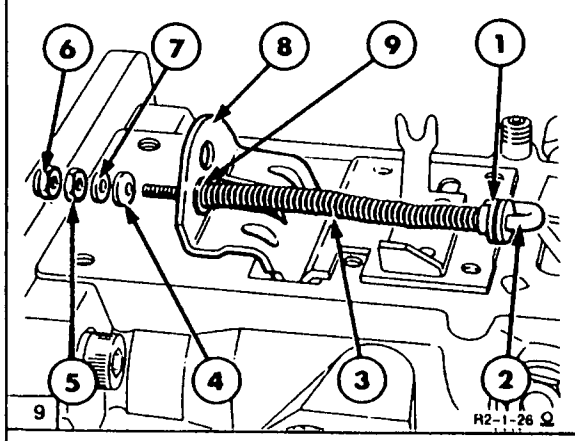

Governor Linkage Disassembly

- | | |
|----------------------|-----------------|
| 1. Spring Retainer | 6. Locknut |
| 2. Linkage Hook | 7. Washer |
| 3. Spring | 8. Governor Arm |
| 4. Pivot Ball Washer | 9. Washer |
| 5. Adjusting Nut | |

1. Unscrew and remove the self locking nut (6), the linkage nut, washer and pivot ball washer from the governor linkage hook, Figure 9.
2. Slowly release the compression on the linkage spring and disengage the linkage hook from the governor arm. Be careful not to lose the washer.
3. Slide the spring and spring retainer from the linkage hook.

Delivery Valves

1. Slacken each delivery valve in turn and remove from the hydraulic head assembly, Figure 10. Remove and discard the sealing washer from each outlet in the hydraulic head.

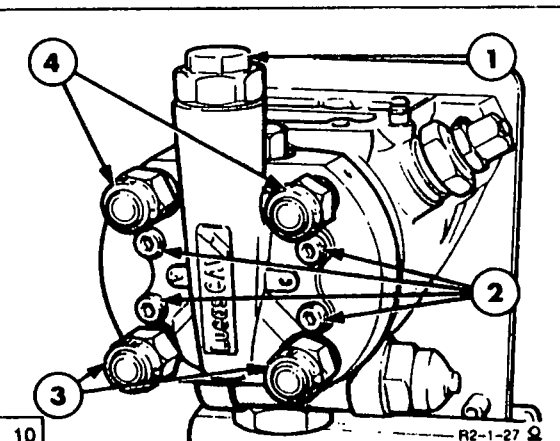

10 R2-1-27 Ω

End Plate and Regulating Valve Assembly

1. Fuel Inlet Connections
2. End Plate Retaining Screws
3. Delivery Valves
4. Delivery Valves

End Plate and Regulating Valve Assembly

1. Slacken the fuel inlet connection in the end plate, Figure 10.
2. Using a suitable allen wrench unscrew the four allen screws and carefully remove the end plate from the hydraulic head.

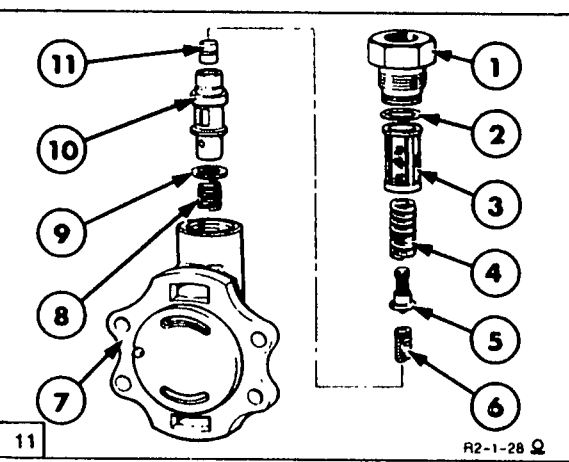

11 R2-1-28 Ω

End Plate and Regulating Valve Components

- | | |
|----------------------|-----------------------|
| 1. Inlet Connection | 7. End Plate |
| 2. 'O' Ring seal | 8. Priming Spring |
| 3. Filter | 9. Sealing Spring |
| 4. Spring | 10. Regulating Sleeve |
| 5. Transfer Pressure | 11. Regulating Piston |
| 6. Spring and Peg | |

3. Remove the fuel inlet connection and discard the 'O' ring seal, Figure 11.
4. Invert the end plate and remove the sleeve, retaining spring and peg assembly, regulating sleeve, piston and priming spring, Figure 9. Discard the sealing washer.

Transfer Pump

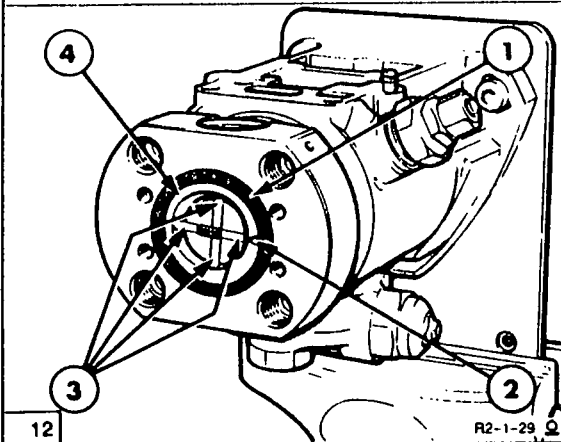

Transfer Pump Components

1. Rubber Seal
2. Rotation Slot
3. Transfer Pump Blades
4. Transfer Pump Liner

1. Remove the transfer pump blades, Figure 12, note the position of the direction of the rotation slot in the transfer pump liner. It should be 3 o'clock when viewed from the transfer pump rotor end. Remove the transfer pump liner and discard the rubber seal.

NOTE: Rotors are loosened in the direction of the pump rotation shown by the arrow on the pump nameplate.

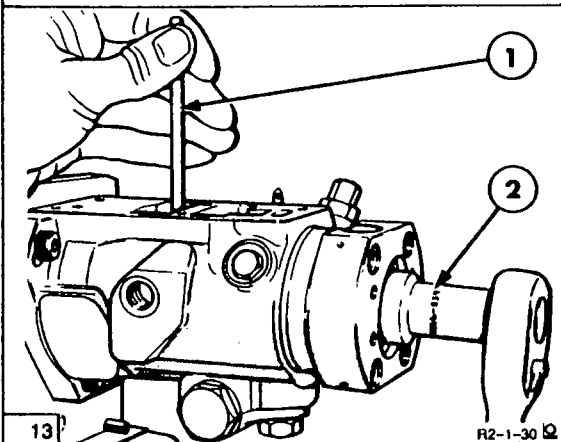

Loosening Transfer Pump Rotor

1. Tommy Bar
 2. Box Spanner Tool No. 7044-889
2. To assist in the removal of the transfer pump rotor, Figure 13. Insert a suitable tommy bar of 4mm (0.157in) diameter through the governor aperture in the pump housing and through the hole in the drive shaft.

3. Still keeping the drive shaft held in with the tommy bar as shown in, Figure 13, insert the box spanner, Tool No. 7044-889 into the slots in the rotor and loosen the rotor.

4. Remove the tommy bar and finger tighten the rotor.

Automatic Advance and Start Retard Unit

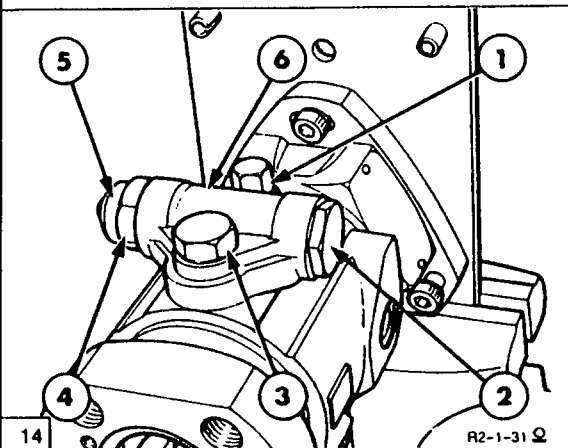

Automatic Advance and Start Retard Unit

1. Cap Nut
2. Piston Plug
3. Head Locating Fitting
4. Spring End Cap
5. Vent Screw
6. Auto-Advance Housing

1. Invert the pump fixture so that the automatic advance and start retard unit is uppermost, Figure 14.

2. Unscrew the piston plug from the housing and remove, discard the rubber 'O' ring.

3. Loosen the spring cap plug and the vent screw. Remove the vent screw and withdraw the three springs.

4. Remove and discard the rubber 'O' ring from the spring cap, then remove the vent screw and discard the rubber washer.

5. Unscrew and remove the cap nut, then remove and discard the copper sealing washer.

6. Unscrew and remove the head locating fitting from the auto-advance housing, taking care not to lose the steel ball and remove and discard both rubber 'O' rings.

7. Gently ease the auto-advance housing with the piston from the pump housing. Remove and discard the housing joint, but retain the piston in the auto-advance housing.

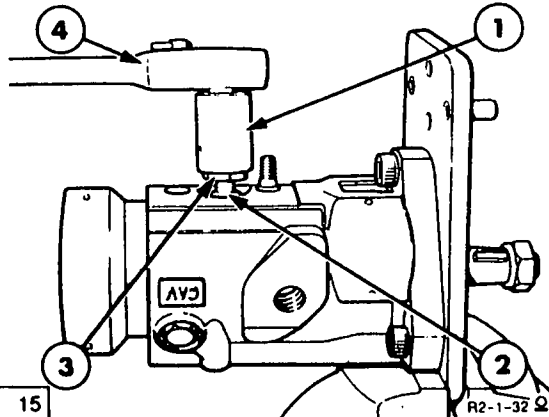

- 15
- Cam Advance Screw
1. Socket
 2. Cam Advance Screw
 3. Socket Adapter Tool No. 7244-125B
 4. Wrench

8. Using the socket adaptor, Tool No. 7244-125B, Figure 15, loosen the cam advance screw.

9. Remove the tool and if necessary lightly tap the cam advance screw to free the cam ring in the pump housing before removing the screw.

10. Invert the mounting fixture so that the governor control cover machined face on the pump housing is uppermost.

Latch Valve

1. Before removing latch valve, Figure 16, loosen both the locknut and sleeve nut in the valve body. Loosen and remove the latch valve body from the pump housing discarding the "Dowty" seal and two rubber 'O' rings.

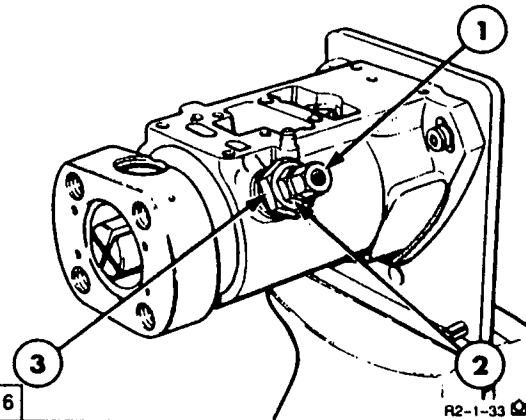

Latch Valve Removal

- 16
- | | |
|---------------|---------------|
| 1. Locknut | 3. Valve Body |
| 2. Sleeve Nut | |
- 2 Remove the locknut, adjuster and tip out the valve spring from the sleeve nut, Figure 17. Remove and discard the rubber washer.

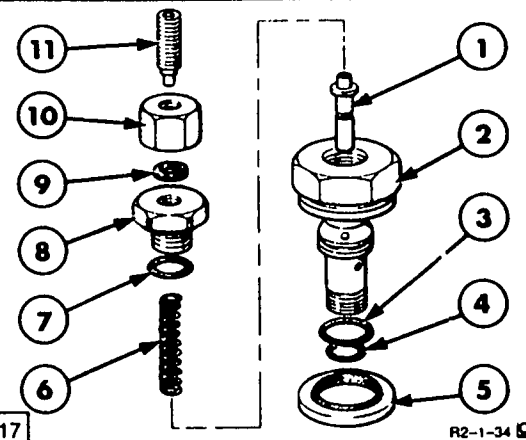

Latch Valve Components

- 17
- | | |
|------------------|------------------|
| 1. Valve | 7. 'O' Ring Seal |
| 2. Valve Body | 8. Sleeve Nut |
| 3. 'O' Ring Seal | 9. Rubber Washer |
| 4. 'O' Ring Seal | 10. Locknut |
| 5. Dowty Washer | 11. Adjuster |
| 6. Valve Spring | |

3 Unscrew and remove the sleeve nut from the latch valve and discard the rubber 'O' Ring.

4 Invert the valve body to bring the externally threaded end uppermost and gently tap to dislodge the valve from the

body. Examine the valve and if the condition is satisfactory, re-assemble the valve to the valve body.

Hydraulic Head

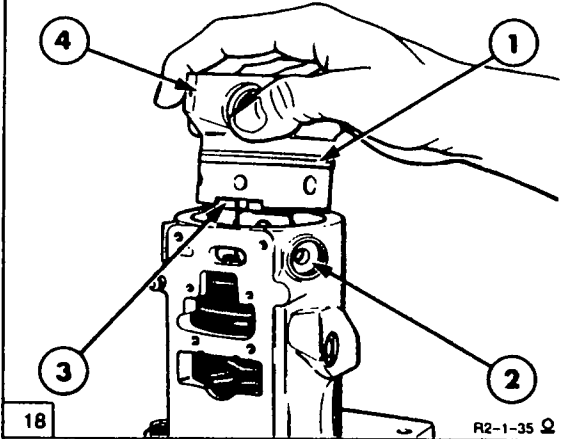

Hydraulic Head Removal

1. 'O' Ring Seal
2. Head Retaining Bolt Location
3. Rear Scroll Plate
4. Hydraulic Head

NOTE: Prior to removing the hydraulic head, turn the pump into the vertical position head

uppermost. This will ensure that the plungers do not fall out of the rotor during the removal of the hydraulic head.

1. With reference to Figure 18, remove the hydraulic head retaining bolt from the side of the pump housing and discard the copper sealing washer.
2. Withdraw the hydraulic head and rotor assembly from the pump housing with a slight twisting motion in each direction. When clear of the housing detach the rear scroll plate noting the direction of the arrow and discard the rubber 'O' Ring from the hydraulic head.
3. The transfer pump rotor, previously loosened should not be removed until the distributor rotor and pump plungers are ready for inspection. To retain the plungers in the rotor fit the plastic retainer C.A.V. Part No. 7174-62, or with suitable synthetic rubber tubing.

Pump Housing and Drive Shaft Assembly

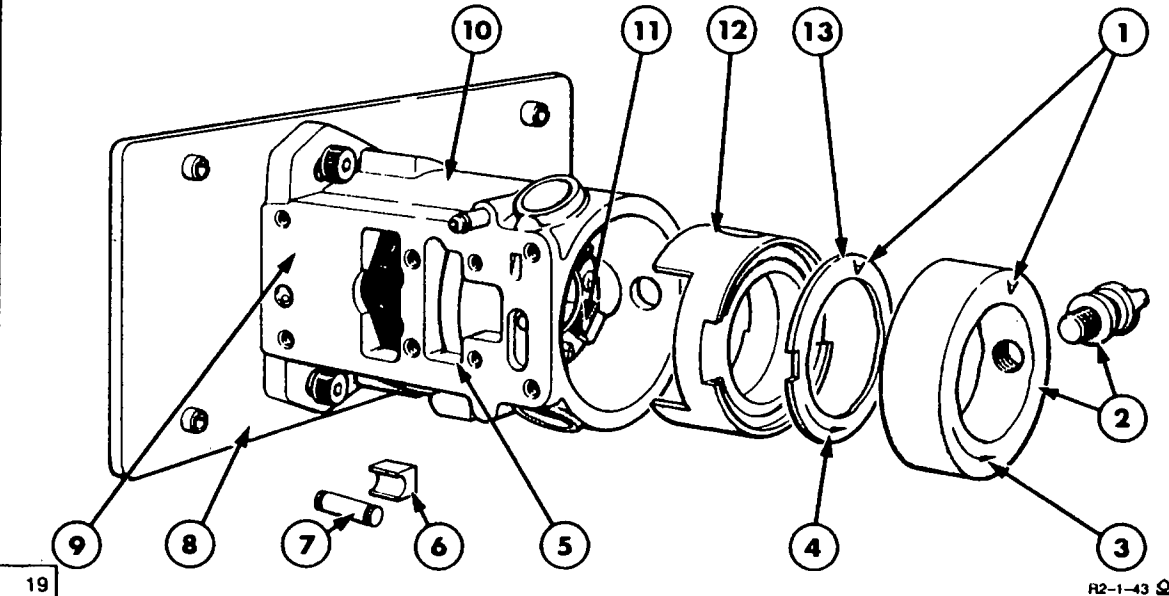

Exploded View of Front Scroll Plate and Cam Ring

- | | | |
|-----------------------------------|--------------------------------|---|
| 1. Matching Letters | 5. "T" Shaped Aperture | 10. Pump Housing |
| 2. Cam Ring and Cam Advance Screw | 6. Shoe } Matched | 11. Shoe and Roller Assembled in Drive Head |
| 3. Direction Arrow Cam Ring | 7. Roller } | 12. Rear Bearing |
| 4. Direction Arrow Scroll Plate | 8. Mounting Plate | 13. Front Scroll Plate |
| | 9. Pump Governor Control Plate | |

1. With reference to Figure 19, turn the pump housing on its mounting fixture so that the pump governor control cover machined face on the housing is at 9 o'clock.
2. Withdraw the cam ring from the pump housing with a twisting motion and detach the front scroll plate noting the direction of the arrows on both cam ring and scroll plate.
3. Rotate the drive shaft to dislodge one roller and shoe assembly into the well of the pump housing and remove the roller and shoe. Repeat the same operation with the other shoe and roller assemblies. Immerse the roller and shoe assemblies in clean test oil.

NOTE: The rollers and shoes are matched and should be kept in their respective assemblies.

4. Remove the woodruff key from the drive shaft. Using suitable snap ring pliers remove the snap ring from the drive shaft and then remove the thrust washer.
5. Remove the pump housing from the mounting fixture and lay the housing on the bench drive end uppermost.

6. While holding the rotor end of the drive shaft through the housing aperture, invert the pump housing so that the tapered end of the driveshaft is uppermost and lift the pump housing clear of the drive shaft assembly and rear bearing, Figure 20.

NOTE: The front drive shaft bearing bush must not be removed. If damaged a new pump housing and bush assembly will be required.

7. Remove the rear bearing and governor weight assembly, Figure 20, from the drive shaft and detach the thrust sleeve, washer and governor weights from the weight retainer.

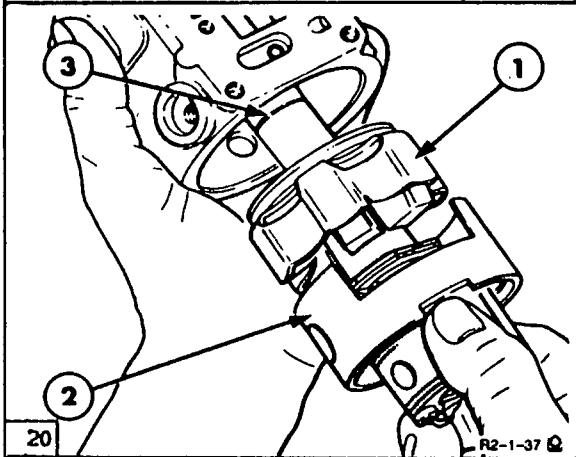

Rear Bearing and Governor Weight Removal

1. Governor Weight Assembly
2. Rear Bearing
3. Drive Shaft

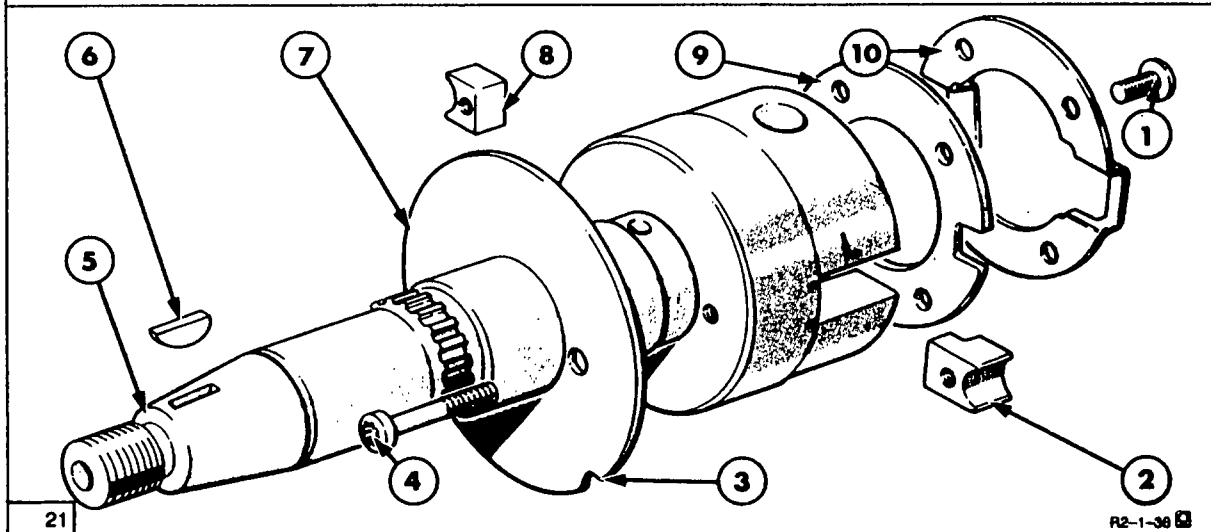

Exploded View of Drive Shaft

- | | | |
|----------------------|-----------------|----------------------|
| 1. "Torx" Screw | 5. Drive Shaft | 8. Short Shoe Spacer |
| 2. Long Shoe Spacer | 6. Woodruff Key | 9. Shoe Plate |
| 3. Timing Disc Notch | 7. Timing Disc | 10. Catch Plate |
| 4. "Torx" Screw | | |

NOTE: Before removing the timing disc and shoe spacers, it will be necessary as an aid to assembly to etch the disc and drive shaft as follows. Mark the timing disc with a vertical line in the same plane as the drive shaft key way. Mark the drive shaft with a letter "L" on the unmachined surface adjacent to the long shoe spacer slot.

9. Again holding the drive shaft, unscrew the two "Torx" screws from the front of the drive shaft. Remove the timing disc and shoe spacers.
10. Remove the oil seal from the pump housing and discard.

INSPECTION OF COMPONENTS

The following information lists the possible defects and indicates the main items which may require replacement. The inspection requirements listed are the minimum advisable. If any part in a mated assembly is damaged or worn, the complete assembly must be renewed. The following items must be considered as mated parts.

**HEAD AND ROTOR ASSEMBLY,
ROLLERS AND SHOES,
ADVANCE PISTON AND BODY,
LATCH VALVE AND BODY,
CAM RING AND SCROLL PLATES,
DRIVE SHAFT HOUSING AND BUSH,
SOLENOID PLUNGER AND BODY.**

1. Check for damage to internal and external threads, especially on the transfer and distributor rotor, hydraulic head, studs, inlet and outlet connections.
2. Look for distorted or fractured springs. Check that all springs quoted in the Parts List for the particular pump are present. In cases of fouling or malfunctioning, ensure the correct springs are fitted.

3. Check for any signs of scoring, wear or corrosion to machined surfaces, including the pump body and bush, drive shaft, rear bearing, hydraulic head bore, cam ring, scroll plates, end plates, auto-advance device location and end plate locating face.
4. When fitting new 'O' rings and oil seals, care must be taken to use protection caps to avoid damage. Inspection of seals after assembly is recommended. Internal seals should be dipped in clean test oil prior to being assembled, external seals should be lightly coated with grease.
5. Inspect for wear and damage to drive shafts, splines and associated parts. If the thrust faces of the housing are worn, check the drive shaft end float.
6. Inspect for wear and scoring of all mechanical linkages, shafts, pivot points, arms and weights.
7. Inspect for nicked, scratched, worn, corroded or otherwise damaged pump plungers and their mated bores.

NOTE: Great care must be taken with pump plungers and bores.

Plungers must only be removed from the bore if there is a need to inspect them and then only for the short time required for inspection. Ensure that each plunger is correctly replaced in the end of the bore from which it came.

Plungers and bores must be cleaned with clean test oil and assembled wet. The plungers should be retained in the bore of the rotor with the plastic retainer, C.A.V. Part No. 7174-62 or with suitable synthetic rubber tubing. The rotor must be assembled to the hydraulic head and the complete assembly immersed in a covered bath of clean test oil until required for assembly.

8. Examine the transfer pump for chipped, broken or worn transfer pump blades. The blades are not interchangeable and replacement blades must be of the same type.
9. Inspect for damage to rollers and shoes. Examine roller surfaces and check for free rotation in shoes. Roller and shoe assemblies must be kept together.
10. Inspect all small orifices for blockage, delivery valve bodies, latch valve, head locating fitting and clear any restriction with dry compressed air.

RE-ASSEMBLY

Drive Shaft

1. With reference to Figure 21, locate the timing disc with the two "Torx" screws to the head of the drive shaft so that the vertical mark previously etched on the disc during dismantling is aligned with the key way on the drive shaft.
2. Fit the short and long spacers into their respective slots in the head of the drive shaft. The long shoe spacer should be located in the slot previously etched with the letter "L". The slots in the spacers must face outwards.
3. Hold the shoe spacers in position and secure the spacers and timing disc with two "Torx" screws.
4. To hold the assembly, insert the drive shaft between the soft jaws of the vice and with a suitable "Torx" bit, tighten to a torque of 25 lbf in (2.8Nm) 0.3 kgf m.
5. Fit the catch plate against the shoe plate and assemble both plates centrally against the rear head of the drive shaft with the four "Torx" screws.
6. Again holding the drive shaft, tighten the screws with a suitable "Torx" bit to 35 lbf in (4.0Nm) 0.4 kgf m.

Governor Weight Assembly

1. Lay the governor "cush" drive assembly on the bench with the weight retainer uppermost, as shown in Figure 20.
2. The governor is fitted with four weights, Figure 22. Fit the weights into the retainer in opposing pairs. The toes of the weights should face inwards and be in contact with the base of the retainer.
3. Insert the thrust washer into the toes of the weights followed by the thrust sleeve tapered end first. Tilting the thrust sleeve to engage with one pair of weights while at the same time lifting the opposite pair, will facilitate entry of the thrust sleeve.

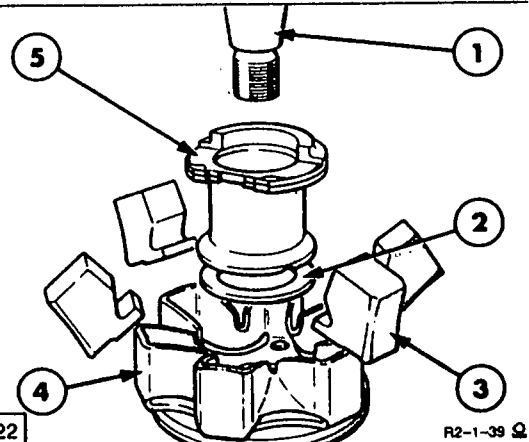

22

R2-1-39 Ω

Governor Weight Assembly

- | | |
|--------------------|-----------------------------------|
| 1. Drive Shaft | 4. Weight Retainer and Cush Drive |
| 2. Thrust Washer | 5. Thrust Sleeve |
| 3. Governor Weight | |

4. Fit the drive shaft assembly through the sleeve and locate the splined teeth on the shaft with those on the splined hub of the cush drive.

Pump Housing and Drive Shaft Assembly

NOTE: The front drive shaft bearing bush is supplied fitted to the pump housing as an assembly.

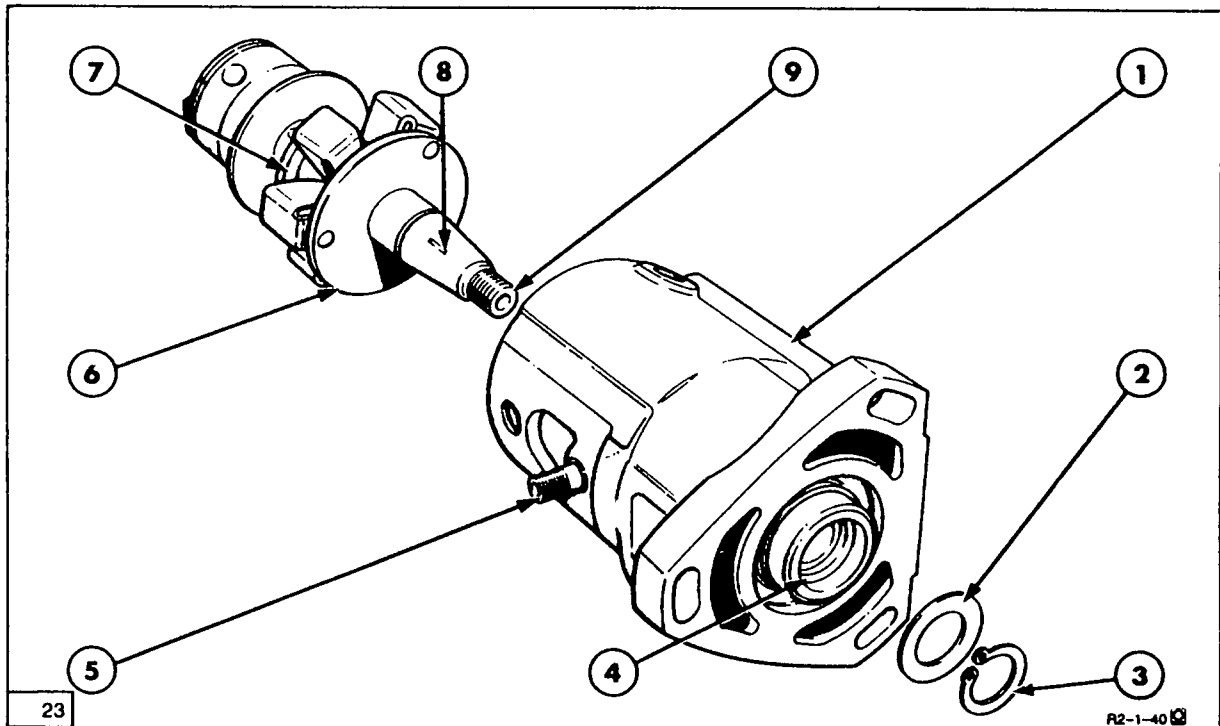

Exploded View of Pump Housing and Drive Shaft

- | | | |
|------------------|------------------------------|---------------------------|
| 1. Pump Housing | 4. Bearing Bush | 7. Governor Thrust Sleeve |
| 2. Thrust Washer | 5. Auto Advance Housing Stud | 8. Key Way |
| 3. Snap Ring | 6. Governor Weight Assembly | 9. Drive Shaft |

1. If the auto-advance housing stud, Figure 23, has been removed from the pump housing, secure the housing to the mounting plate, Tool No. 7244-200 and mount the fixture in the jaws of a vice so that the housing stud aperture is uppermost.
2. Screw in a new stud using a locknut and capnut and tighten the stud to 60 lbf in (6.8Nm) 0.7 kgf m.
3. Reposition the pump mounting fixture, so that the governor cover machined face on the pump housing is uppermost.
4. Insert the drive shaft and governor weight assembly into the pump housing and rotate the drive shaft so that the machined flat is uppermost.
5. Slide the thrust washer over the end of the drive shaft and abut against the pump housing. Retain the thrust washer with the snap ring.
6. After assembly check the drive shaft end float and if necessary adjust, as per the following procedure.

Checking of Drive Shaft End Float

1. To assist in checking the drive shaft end float, temporarily fit the rear bearing, Figure 26, to support the drive shaft.

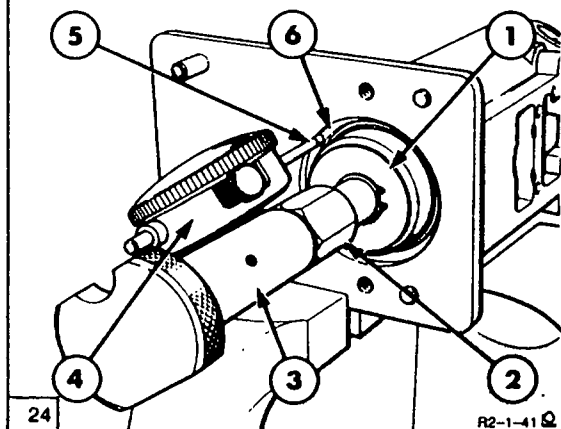

Drive Shaft End Float Check

1. Thrust Washer
2. Adaptor Tool No. 89559/11
3. Holder Tool No. ST183
4. Dial Indicator Tool No. 23764
5. Stylus
6. Pump Housing

2. Fit an adaptor, Tool No 89559/11, to the threaded end of the drive shaft. Screw in the holder, Tool No. ST 183 (3). Adjust the stylus to contact the machined face of the pump housing, Figure 24.
3. Push the drive shaft inwards and zero the dial gauge Tool No. 23764. Pull the drive shaft outward and note the maximum reading on the gauge. The drive shaft end float should be between a maximum of 0.008in (0.2mm) and a minimum of 0.002in (0.05mm). If necessary, adjust the end float by selective assembly of the thrust washers.
4. Thrust washers of variable thickness are available to adjust the drive shaft end float to specification.
5. When the end float has been checked remove the rear bearing, snap ring and thrust washer. Then remove the pump housing from the mounting fixture and stand the housing upright on the bench.

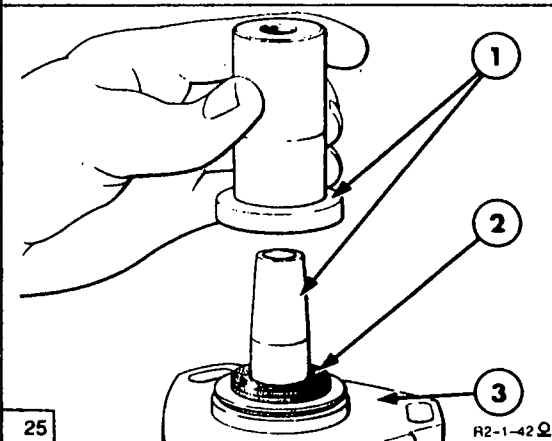

Drive Shaft Oil Seal Installation

1. Punch and Protection Cap Tool No. 7244-445
 2. Oil Seal
 3. Pump Housing
6. Fit the protection cap of Tool No. 7244-445, over the threaded end of the tapered shaft, Figure 25.
 7. Immerse a new drive shaft oil seal in clean test oil. Slide the seal over the protection cap with the lip of the seal facing inwards towards the recess in the pump housing.

8. With the punch of Tool No. 7244-445 drive the seal into the housing by tapping squarely with a hide mallet, until the tool abuts the face of the pump housing spigot.
9. When correctly fitted the outer face of the oil seal should be recessed approximately 0.008in (0.2mm) from the end face of the housing. Check that the shaft is able to rotate freely without excessive drag.
10. Refit the pump housing back onto its mounting fixture with the governor cover machined face uppermost. Re-install the selected thrust washer and retain with the snap ring.

Rear Bearing, Cam and Scroll Plates

1. Position the pump housing mounting fixture with the governor cover machined face at 9 o'clock. Alternatively, the pump may be fitted in the vertical position with the drive end downwards.
2. Fit the rear bearing into the pump housing with the large cut-away section of the bearing towards the drive shaft, Figure 26 and the axial slot in the bearing positioned at 3 o'clock to the rear of the auto-advance stud. Push the bearing fully in so that the chamfered edge on the bearing abuts the shoulder within the pump housing.

3. To aid assembly it is recommended that the roller and shoe assemblies are gripped with a suitable pair of tweezers. Keep the matched shoes and rollers in their respective assemblies and insert them through the "T" shaped aperture in the housing. When the slots in the head of the drive shaft are in the horizontal position.
4. To prevent the shoes and rollers being dislodged, fit the first set at 9 o'clock and rotate the shaft 180° in a clock wise direction viewed from the open end of the housing. The opposite shoe and roller assembly can then be fitted.
5. The arrows on both scroll plates and cam ring indicate the direction of pump rotation as viewed from the drive shaft end.
6. Insert the front scroll plate into the recess in the rear bearing with the arrow on the plate facing the same direction as the arrow on the pump name plate, Figure 26.

NOTE: The cam and scroll plates are a matched set and can be identified by a grade letter etched on the side of the ring and plate.

7. Ensure that the scroll plate rotates freely and position the notch in the plate mid-way between the cut-away section in the rear bearing.
8. Fit the cam ring with the arrow facing in the same direction as the arrow on the pump plate, Figure 26. Align the threaded hole in the ring, with the automatic advance aperture in the housing.
9. Fit the cam advance screw into the cam ring, finger tight.

NOTE: Do not at this stage fit the rear scroll plate to the pump housing, this should be assembled with the hydraulic head.

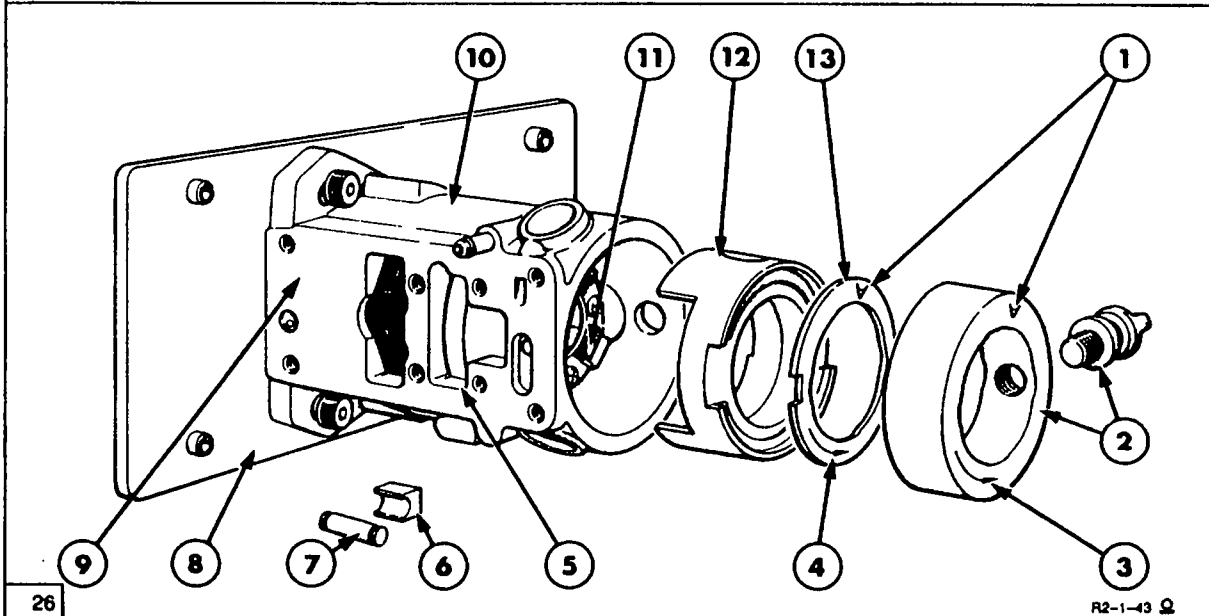

26

R2-1-43 Ω

Exploded View of Front Scroll Plate and Cam Ring

- | | | |
|-----------------------------------|--------------------------------|---|
| 1. Matching Letters | 5. "T" Shaped Aperture | 10. Pump Housing |
| 2. Cam Ring and Cam Advance Screw | 6. Shoe } Matched | 11. Shoe and Roller Assembled in Drive Head |
| 3. Direction Arrow Cam Ring | 7. Roller } Matched | 12. Rear Bearing |
| 4. Direction Arrow Scroll Plate | 8. Mounting Plate | 13. Front Scroll Plate |
| | 9. Pump Governor Control Plate | |

Hydraulic Head

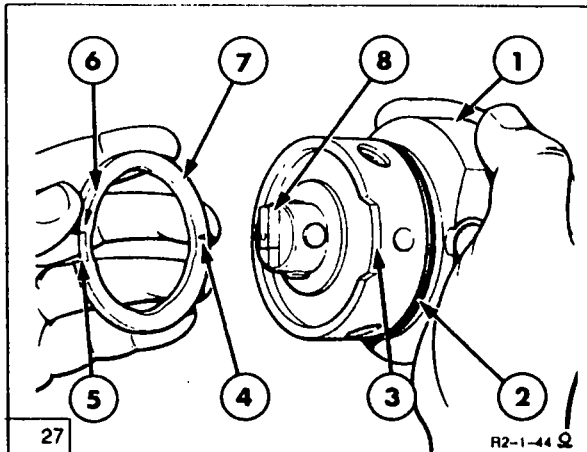

Rear Scroll Plate Installation

1. Hydraulic Head
2. 'O' Ring Seal
3. Cut Away Section in Hydraulic Head
4. Matching Letter
5. Notch in Scroll Plate
6. Direction Arrow Scroll Plate Rotation
7. Rear Scroll Plate
8. Rotor Tang

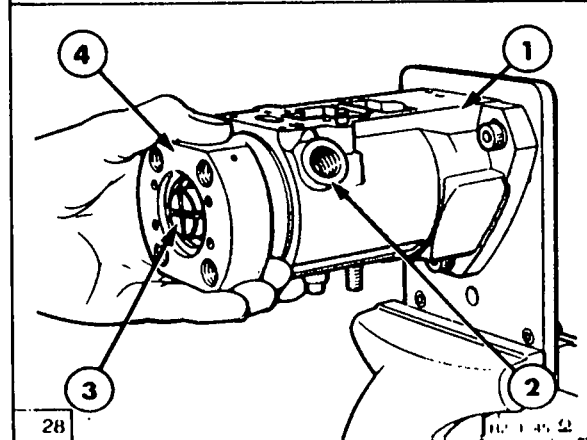

Hydraulic Head Installation

1. Pump Housing
 2. Latch Valve Aperture
 3. Rotor
 4. Hydraulic Head
1. Fit a new rubber 'O' ring into the groove in the hydraulic head and assemble the head into the pump housing as follows:-
 2. Turn the mounting fixture in the vice so that the governor cover machined face on the pump housing is uppermost, Figure 28.
 3. Remove the plastic plunger retainer from the motor tang.

4. Using a suitable pair of tweezers move the shoe assemblies to their innermost positions.
5. Check the position of the tang slot location in the drive shaft and align the tang on the rotor to correspond.
6. Smear clean test oil on the portion of the hydraulic head that fits into the pump housing and keeping the rotor steady with thumb to prevent rotation, insert the head into the housing with a rotating motion, Figure 28. Rotating the head during assembly will facilitate entry and prevent possible damage to the head.

NOTE: When fitted check the tang drive has engaged fully by ensuring that the transfer pump rotor is in the innermost position, that is, nearest to the head sleeve and flush with the rear face of the hydraulic head.

7. Align the holes in the hydraulic head for the latch valve and head locating bolt with the respective holes in the pump housing. In this position the metering valve ports should be uppermost.

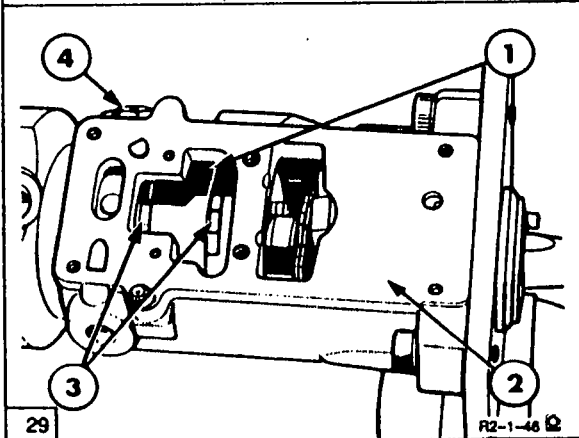

Scroll Plate Alignment

1. "T" Shaped Aperture
 2. Governor Cover Machined Face
 3. Scroll Plates
 4. Head Locating Bolt
8. Ensure that the notches in the scroll plates are positioned between the "T" shaped aperture in the governor cover machined face, Figure 29.
 9. Fit a new copper sealing washer then install the head locating bolt, Figure 29, into the pump housing and tighten to 170 lbf in (19.0Nm) 2.0 kgf m.

Automatic Advance Housing Assembly

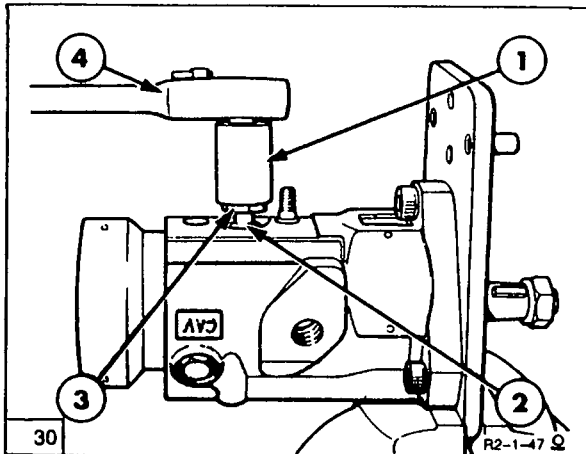

Tightening Cam Advance Screw

- 1. Socket
- 2. Cam Advance Screw
- 3. Socket Adaptor Tool No. 7244-125B
- 4. Wrench

1. Invert the pump fixture so that the cam advance screw is uppermost.
2. Using the socket adaptor Tool No. 7244-125B, Figure 30. Tighten the cam advance screw to 450 lbf in (51.0Nm) 5.2 kgf m.
3. Remove the tool, check for freedom of movement and if the cam ring is binding, lightly tap the cam advance screw to ensure the cam ring is free in the pump housing.
4. Using the protection sleeve Tool No. 7044-897, fit two new rubber 'O' rings to the head locating fitting. Fit the steel ball on its seating in the fitting and insert the assembly into the auto-advance housing to retain the ball.
5. Fit a new gasket to the automatic advance housing.

NOTE: The piston and auto-advance housing are a matched pair.

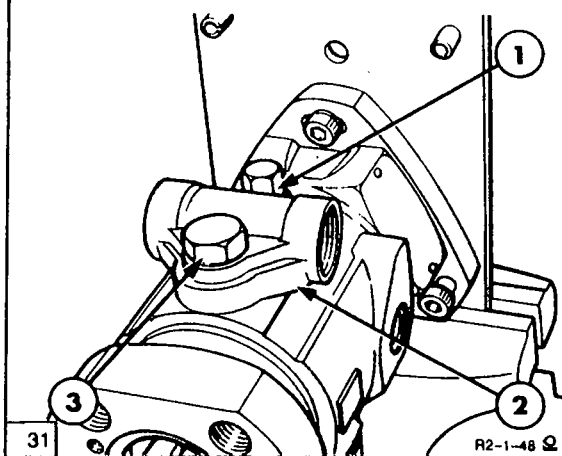

Exploded View of Advance Housing

- 1. Cap Nut
 - 2. Advance Housing
 - 3. Head Locating Fitting
6. Check that the blank (pressure) end of the piston is towards the oil feed drilling end of the housing and fit the advance unit to the pump housing. By engaging the bore in the piston with the cam advance screw, finger tighten the head locating fitting, Figure 31.
 7. Fit a new copper sealing washer to the housing stud and screw on the cap nut finger tight.
 8. Invert the mounting fixture in the vice so that the pump governor cover machined face on the pump is uppermost.

Latch Valve

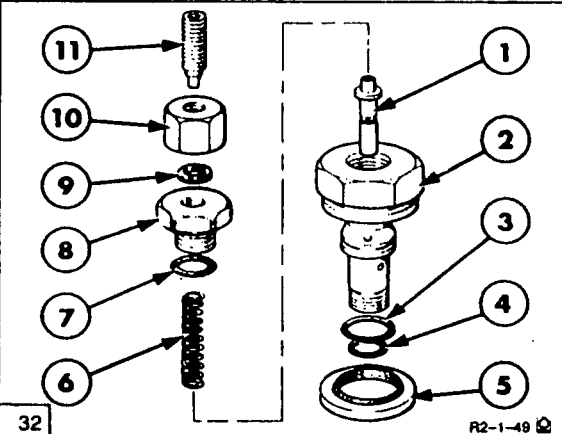

Exploded View of Latch Valve

- 1. Valve
- 2. Valve Body
- 3. 'O' Ring seal
- 4. 'O' Ring seal
- 5. Dowty Washer
- 6. Valve Spring
- 7. 'O' Ring Seal
- 8. Seal Nut
- 9. Rubber Washer
- 10. Locknut
- 11. Adjuster

NOTE: When new the valve and body of the latch valve are supplied as a matched assembly fitted with plastic protection caps to retain the valve in situ.

1. If new, remove the plastic plugs from the latch valve and assemble as follows referring to, Figure 32.
2. Screw the adjuster into the locknut and leave several threads exposed at the top of the nut. Fit a new rubber washer into the recess provided in the locknut.
3. Using the protection sleeve, Tool No. 7144-18, fit two new rubber 'O' rings to the valve body. Using the protection sleeve Tool No. 7144-458C, fit a new rubber 'O' ring to the sleeve nut.
4. Fit the latch valve and body with a new "Dowty" seal into the 2 o'clock position in the pump housing when viewed from the rear end of the pump.
5. Tighten the valve body to 170 lbf in (19.0Nm) 2.0 kgf m. With a suitable pair of tweezers, check for free movement of the valve in the valve body.
6. Screw on the sleeve nut then fit the spring against the valve.
7. Engage the stem of the adjuster with the spring and screw the adjuster and locknut into the sleeve nut. Tighten the sleeve nut to 140 lbf in (15.6Nm) 1.6 kgf m, followed by the adjuster locknut and tighten to 40 lbf in (4.5Nm) 0.45 kgf m.

Automatic Advance and Start Retard Unit

1. Progressively and evenly tighten both the head locating fitting and cap nut. Tighten the fitting and the cap nut to 130 lbf in (15.0Nm) 1.5 kgf m. Check that both cam ring and piston move freely.

2. Fit the remaining parts of the advance unit as follows, referring to Figure 33.

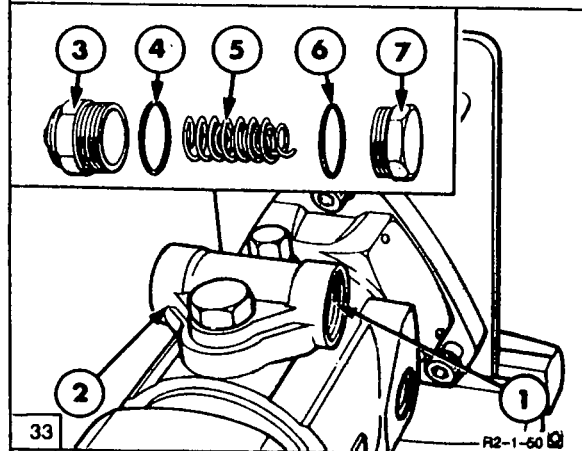

Exploded View of Advance Housing Components

1. Piston Plug Position
 2. Spring Cap Position
 3. Spring Cap
 4. 'O' Ring Seal
 5. Springs (3 off)
 6. 'O' Ring Seal
 7. Piston Plug
3. Using the Protection Sleeve, Tool No. 7044-898 over the threads of the piston plug (7), fit a new rubber 'O' ring. Screw the piston plug into the advance housing and tighten the plug to 250 lbf in (28.0Nm) 2.9 kgf m.
 4. Using the Protection Sleeve, Tool No. 7044-898, fit a new rubber 'O' ring over the threads of the spring cap (3).
 5. Fit the advance springs into the piston and screw the spring cap into the housing.
 6. Using a suitable socket tighten the spring cap to 250 lbf in (28.0Nm) 2.9 kgf m.

Transfer Pump

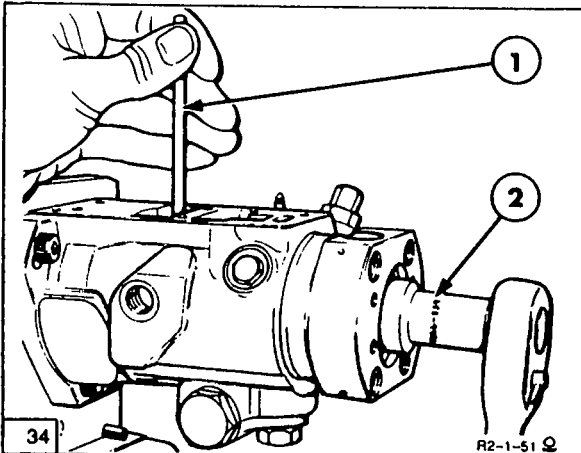

Tightening Transfer Pump Rotor

1. Tommy Bar
2. Box Spanner Tool No. 7044-898

1. To prevent the drive shaft from turning, insert a suitable tommy bar of 0.157 in (4mm) diameter through the front aperture in the pump housing and through the hole in the drive shaft, referring to Figure 34.
2. Insert the special box spanner, Tool No. 7044-889, into the slots in the transfer pump rotor and tighten the rotor to 65 lbf in (7.3Nm) 0.75 kgf m.

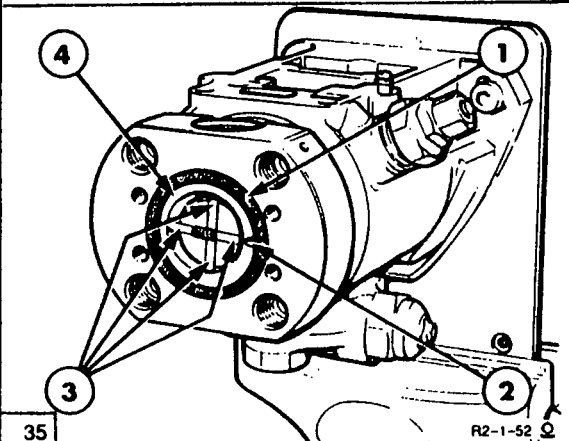

Transfer Pump Components

1. Rubber Seal
2. Rotation Slot
3. Transfer Pump Blades
4. Pump Eccentric Liner

NOTE: The transfer pump rotor must be tightened in the opposite direction to the pump rotation.

3. Ensure when the rotor is fitted that the transfer pump blades (3), Figure 35, all slide freely in the slots of the rotor and then remove.
4. Before assembling the transfer pump liner into the hydraulic head ensure that the direction of the rotation slot in the side of the liner is positioned correctly at 3 o'clock when viewed from the rotor end.
5. Insert the liner into the hydraulic head. Dip the transfer pump blades in clean test oil and insert the blades and springs into the slots of the transfer pump rotor. Check again that the blades move freely.
6. Lubricate the transfer pump rubber sealing ring with clean test oil and fit into the recess between the liner and the hydraulic head.

End Plate and Regulating Valve Assembly

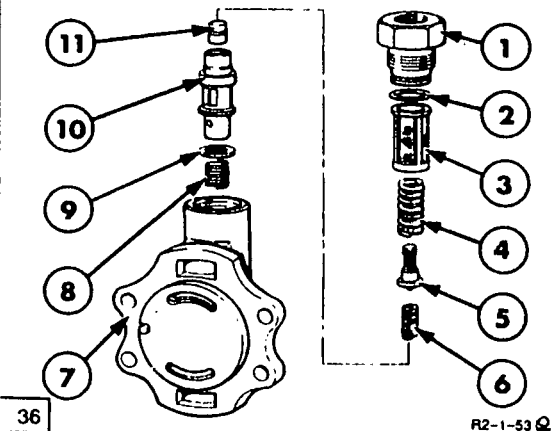

End Plate and Regulating Valve Components

- | | |
|-------------------------------|-----------------------|
| 1. Inlet Connection | 6. Spring and Peg |
| 2. 'O' Ring Seal | 7. End Plate |
| 3. Filter | 8. Priming spring |
| 4. Spring | 9. Sealing Washer |
| 5. Transfer Pressure Adjuster | 10. Regulating Sleeve |
| | 11. Regulating Piston |

1. To assemble the regulating valve, Figure 36, hold the end plate (7) and insert the priming spring (8) into the well of the end plate. Fit a new sealing washer to the small diameter end of the regulating sleeve (10) and hold the sleeve with the sealing washer end down, block this end of the sleeve with a finger.
2. Insert into the open end of the sleeve the regulating piston (11), spring and peg assembly (6) with peg uppermost, followed by the transfer pressure adjuster (5).

3. Fit the sleeve retaining spring to the flange of the adjuster and to retain the complete assembly, push the filter into position against the shoulder of the regulating sleeve.
4. Hold the assembly in a horizontal plane and with the end plate similarly aligned, slide the complete assembly into the end plate.
5. Screw in the inlet connection complete with new 'O' ring seal into the end plate finger tight.

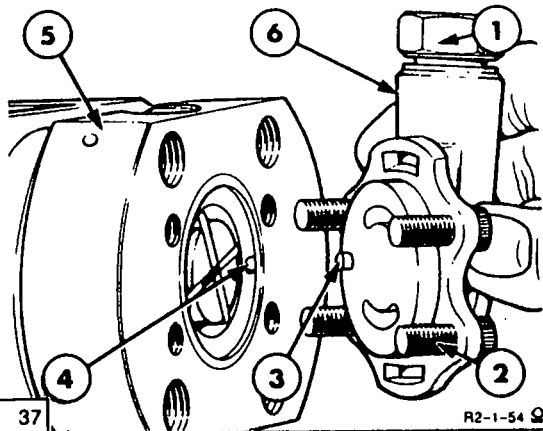

End Plate Installation

- | | |
|---------------------|-------------------|
| 1. Inlet Connection | 4. Slot |
| 2. Hexagon Screw | 5. Hydraulic Head |
| 3. Dowel | 6. End Plate |
6. Fit the end plate assembly, Figure 37, with the fuel inlet connection uppermost onto the hydraulic head ensuring that the dowel on the inner face of the end plate engages with the slot in the transfer pump liner.
 7. Fit the four hexagon screws to the end plate whilst rotating the drive shaft to ensure that the drive remains free, tighten the screws carefully in diagonal sequence to 45lbf in (5.0Nm) 0.5 kgf m.
 8. Tighten the fuel inlet connection to a torque of 520 lbf in (50Nm) 6.0 kgf m.

Governor Arm Control Bracket Assembly

1. Assemble the governor spring linkage components, Figure 38, on to the linkage hook in the following order:-
2. Spring retainer large end first, long linkage spring and fibre washer. Pass the linkage hook through the small hole in the governor arm and continue assembling the pivot ball washer, washer, linkage nut and locknut.

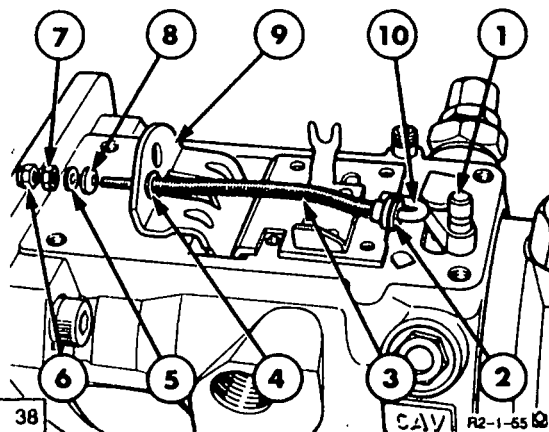

Governor Spring Linkage Components

- | | |
|--------------------|----------------------|
| 1. Metering Valve | 6. Locknut |
| 2. Spring Retainer | 7. Linkage Nut |
| 3. Spring | 8. Pivot Ball Washer |
| 4. Washer | 9. Governor Arm |
| 5. Washer | 10. Linkage Hook |

3. Insert the metering valve into the metering valve bore in the hydraulic head.

NOTE: Before assembling the control arm and bracket, check that the notches in the front and rear scroll plates are centrally positioned between the "T" shaped aperture in the pump housing as shown, Figure 29.

1. Ensure that the step on the governor thrust sleeve is uppermost.

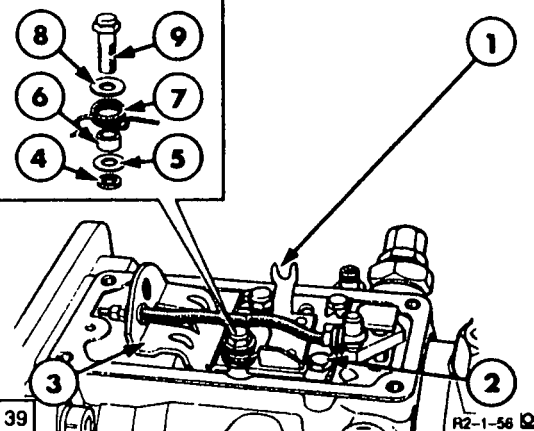

Governor Control Bracket

- | | |
|-----------------|-----------|
| 1. Link Plate | 6. Sleeve |
| 2. Screw | 7. Spring |
| 3. Governor Arm | 8. Washer |
| 4. Spacer | 9. Screw |
| 5. Washer | |

2. Engage the control bracket with the governor arm and position into the pump housing by placing the toes at the lower end of the governor arm on top of the step on the governor thrust sleeve. At the same time, align the legs on the link plate to engage with the notches in the scroll plates.
3. Position new tab washers on the control bracket. Screw in the hexagon headed screws and tighten to 20 lbf in (2.3Nm) 0.23 kgf m. Lock all tab washers by bending them over the screw heads.
4. Assemble the link plate spring, washers and sleeve onto the retaining bolt and install the bolt into the housing, refer to inset Figure 39, tighten to 20 lbf in (2.3Nm) 0.23 kgf m.
5. To tension the spring, hook the short leg of the spring behind the stud and abut the link in the long leg of the spring against the inner tongue on the link plate.
6. Attach the metering valve to the hook as illustrated and ensure that the linkage moves freely.

To Set The Governor Linkage

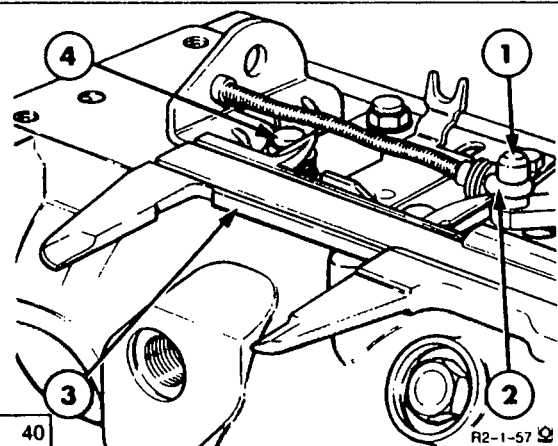

Setting The Governor Linkage

1. Metering Valve Linkage Pin
 2. Linkage Hook
 3. Vernier Gauge
 4. Control Bracket Retaining Bolt
1. Set the linkage length using a vernier gauge as shown in Figure 40, so that the correct dimension as stated on the Test Plan, see "Section G", is obtained, measured inside between the diameters of the link plate stud and the metering valve linkage pin.

2. When setting ensure that the vernier gauge is held as shown in Figure 40 and apply a light pressure to the governor arm to hold the metering valve in the fully open position. Ensure that the measuring caliper does not enter the hook location groove on the metering valve pin. The opposite leg of the caliper should engage the rounded portion above the hexagon stud. Slacken the locknut and adjust the adjuster nut.
3. After setting, tighten the linkage locknut to 20 lbf in (2.3Nm) 0.23 kgf m.

Throttle Shaft

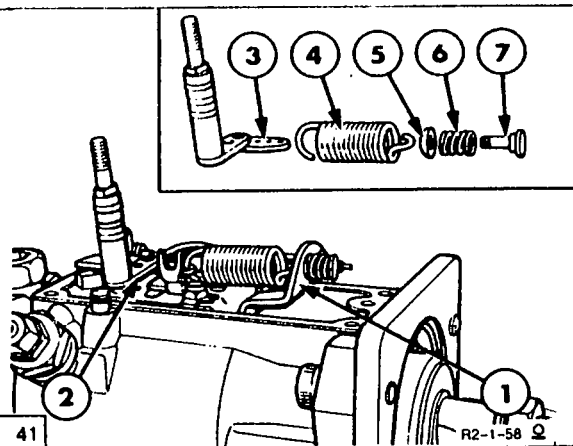

Throttle Shaft and Governor Main Control Spring

1. Governor Control Arm
 2. Throttle Shaft
 3. Throttle Shaft Link
 4. Governor Main Spring
 5. Pivot Ball Washer
 6. Idling Spring
 7. Idling Spring Guide
1. Fit the protection sleeve, Tool No. 7244-458C over the threads of the throttle shaft and slide the new rubber 'O' rings into position on the shaft.
 2. Install the idling spring onto its guide and press the guide through the hole in the governor control arm. Secure by fitting the governor main control spring to the guide, Figure 41.
 3. Connect the free end of the governor main control spring to the throttle shaft link.
 4. Fit the governor control cover gasket to the pump housing, ensuring that the holes align with those in the pump housing.

5. Fit the protection sleeve, Tool No. 7144-458C over the fuel shut-off shaft and slide the new 'O' rings into position on the shaft.
6. Insert the fuel shut-off lever through the bore in the control cover and push into position.
7. Fit the cap washer to the fuel shut-off lever shaft. Assemble the return spring to the fuel shut-off lever then assemble the lever and spring onto the lever shaft and retain the lever with the hexagon headed screw, tighten to 30 lbf in (3.4Nm) 0.35 kgf m.
8. Insert the throttle shaft through the bore in the control cover and push the shaft into position.
9. Install the excess fuel device piston into the control cover.
10. Lower the cover towards the pump housing and at the same time depress the excess fuel piston whilst holding the link plate in the excess fuel position with a screwdriver, to engage the excess fuel shaft with the link plate.
11. Insert the four hexagon socket screws with washers into the governor control cover and using a suitable allen wrench, tighten the four screws uniformly to 35 lbf in (4.0Nm) 0.4 kgf m.

Maximum Fuel Adjustment Screw

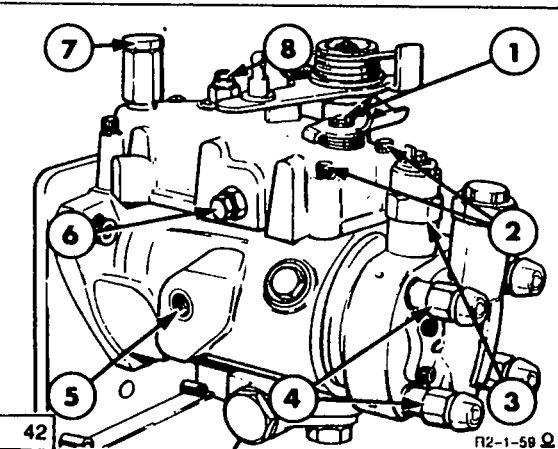

Governor Control Cover Components

1. Fuel Shut-Off Set Bolt
 2. Governor Cover Screws
 3. Solenoid Shut-Off Valve
 4. Delivery Valves
 5. Drain Plug
 6. Maximum Fuel Adjustment Screw
 7. Pressurising Valve
 8. Vent Screw
1. Screw the adjuster into the locknut, Figure 42 and fit a new rubber washer into the recess in the locknut.

2. Screw the adjuster into the governor control cover, Figure 42, approximately halfway down the threads on the screw and tighten the locknut to 30 lbf in (3.4Nm) 0.35 kgf m.

Delivery Valves

1. Insert new sealing washers into the high pressure outlet bores and install the delivery valve assemblies into the bores. Tighten the delivery valves to 360 lbf in (41.0Nm) 4.1 kgf m.

Throttle Lever Assembly

1. Pull the throttle shaft fully upwards into the control cover.
2. Fit the cap washer over the throttle shaft onto the boss of the cover. Assemble the throttle lever, break back spring and spring guides, then install over the throttle shaft.
3. Fit the plain washer onto the throttle shaft and install the locknut, tighten to 40 lbf in (4.5Nm) 0.45 kgf m.
4. Fit the maximum speed screw and secure with the locknut. Fit the idle adjustment screw to the governor control cover and secure with the locknut.
5. Using the protection sleeve, Tool No. 1804-429, fit the sealing washer to the drain plug and screw the plug into the pump. Tighten the drain plug to 40 lbf in (4.5Nm) 0.45 kgf m.

Excess Fuel Device

1. Slide a new 'O' ring seal onto the excess fuel device plug. Install the plug into the governor control cover and retain with the snap ring.

Solenoid Shut-Off Valve

1. Install a new rubber 'O' ring on to the solenoid body using protection cap, Tool No. 7044-897. Insert the spring into the solenoid plunger and place the solenoid body over the spring plunger assembly.
2. Screw the solenoid assembly into the hydraulic head and tighten the solenoid to 250 lbf in (28.0 Nm) 2.9 kgf m.

Pressurising Valve

1. Install the pressurising valve with a new sealing washer into the governor control cover and tighten to 180 lbf in (20.0Nm) 2.0 kgf m.

Vent Screw

1. Fit the vent screw with a new copper washer and screw into the governor control cover. Tighten the vent screw to 40 lbf in (4.5Nm) 0.45 kgf m.

INJECTION PUMP TIMING

In production the setting of the distributor type fuel injection pump to engine timing involves the use of specialised equipment, which eliminates the effects of backlash in the timing gears. The removal of backlash in the timing gears effectively advances the timing by 2 degrees.

IMPORTANT: *Injection pump to engine timing cannot be checked by alignment of the scribed line on the pump flange with the zero degree mark on the rear of the engine front plate. The timing can only be established by internal timing of the pump after removal from the engine.*

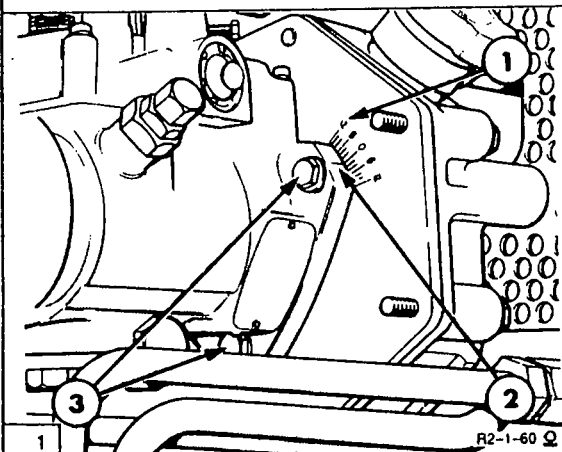
**Fuel Injection Pump Timing Mark**

1. Timing Marks on Engine Front Plate
2. Scribe line on Injection Pump
3. Injection Pump Retaining Bolts

To eliminate the effects of timing gear backlash when installing an internally timed pump, advance the engine timing 2 degrees by rotating the pump clockwise (as viewed from

the rear end) half a division relative to the zero degree mark on the rear of the engine plate, Figure 1.

If the pump is not to be internally timed then prior to removal note the setting of the pump relative to the zero degree mark on the rear of the engine front plate. Mark the plate with a centre punch to align with the pump flange scribed line.

This mark may be used as a reference point to which the original, re-conditioned or new pump should be set on installation.

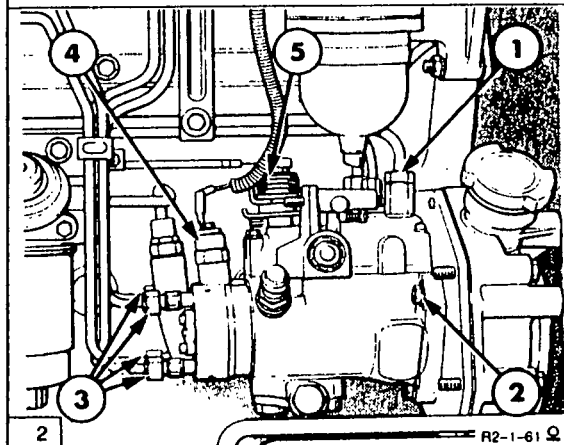
INSTALLATION**Fuel Injection Pump Installation**

1. Fuel Retain Line
2. Pump Retaining Bolt
3. Injector Lines
4. Fuel Shut-Off Solenoid
5. Throttle Linkage

1. After testing and adjusting the pump to give the correct fuel deliveries, refer to "Setting data". Install a new pump to front engine plate 'O' ring on the pump mounting flange.
2. Install the three injection pump to engine front plate mounting bolts.

If the pump has been internally timed, rotate the pump clockwise as viewed from the rear end, half a division relative to the zero degree mark on the rear of the engine front plate.

If the pump has not been internally timed, align the scribed line on the pump flange with the centre punch reference mark previously made on the rear of the engine front plate. Tighten the mounting bolts to 20 lbf ft (27.0Nm) 2.7 kgf m.

3. Install the pump drive gear, aligning the gear with the woodruff key on the pump drive shaft. Also ensure that the drive gear timing mark aligns with the gear timing mark.

4. Install the lockwasher and retaining nut to the pump drive shaft and tighten to 58 lbf ft (79.0Nm) 7.9 kgf m.
5. Position a new inspection cover gasket and install the inspection cover to the engine front cover, tighten the retaining bolts to 18 lbf ft (25.0Nm) 2.5 kgf m.
6. Connect the fuel lines to the injection pump, Figure 2 and tighten to 20 lbf ft (27Nm) 2.7kgf m.
7. Reconnect the throttle and fuel shut-off controls to the injection pump.
8. Reconnect the bottom radiator hose and tighten the retaining clamps to 18 lbf ft (24.4Nm) 2.5 kgf m and refill the coolant system, refer to operators manual for correct specifications.
9. Turn on the fuel supply and prime the system using the hand primer mounted on the fuel *pump* assembly. Start the engine and adjust the engine idle and maximum no load speeds.

**FUEL INJECTION PUMP –
SPECIAL TOOLS**
DESCRIPTION
General
LESLIE HARTRIDGE TOOL No

Pump Mounting Plate	7244 – 200
Cam Advance Screw Socket	7244 – 125B
Transfer Pump Rotor Box Spanner	7044 – 889
Timing Adaptor Assembly	7144 – 262
Flange Marking Tool	7244 – 27
Insert for Flange Marking Tool	7244 – 30
Static Timing Gauge	7244 – 449
Relief Valve	7144 – 155
Stirrup Pipe	7144 – 262A
Blank-Off Bolt	7144 – 558
Plunger Timing Tool	7244 – 448
Transfer Pressure Adjuster	7244 – 410A
Adaptor Hydraulic Head for	
Transfer Pressure Gauge	7244 – 382
Advance Measuring Gauge	7244 – 447
Pressure End Plug Test Plug	7244 – 435
Punch and Adaptor Drive Shaft Seal	7244 – 445
Dial	23764
Dial Indicator Holder	ST 183
Dial Indicator Holder Adaptor	89559

Protection Caps

Head Locating Fitting	7044 – 897
Latch Valve Body Seals	7144 – 18
Latch Valve Restrictor Plug Seal	7144 – 124
Latch Valve Sleeve Nut Seal	7144 – 458C
Throttle Shaft Seals	7144 – 458C
Fuel Shut-Off Seals	7144 – 458C
Auto Advance Cap and Plug Seals	7044 – 898

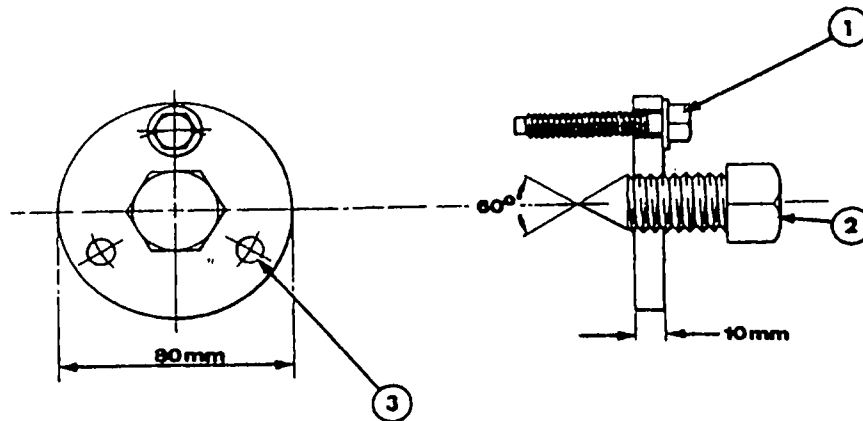

4

1R-2-10-

Fuel Injection Pump Drive Gear Puller

1. Bolt 5/16 – UNF x 2 in (51mm), with Integral Washer (3 Bolts required)
2. Bolt 3/4 x 16 – UNC x 2 in (51mm)
3. 3 Holes 0.375 in (9.5mm) dia on 2.2 in (56.87mm) dia equally spaced material of 0.394 in (10mm) Plate HRLC P&O Steel.

GENERAL TORQUES
FUEL SYSTEM

	lbf/ft	Nm	kgf/m
Throttle Cable Lock Nuts	37	50	5.1
Throttle Lever Stop Bolt Locknut	7	10	1.0
Fuel Tank Shut-Off Valve	9	12	1.2
Thermostart Plug	27	37	3.8
Thermostart Pipe Union	7	10	1.0
Leak-Off Pipe to Injector Line	18	24	2.4
Fuel Tank Sender Retaining Ring	18	24	2.4
Fuel Filter Element Retaining Bolt	7	10	1.0
Fuel Filter Retaining Bolts	22	30	3.1
Air Cleaner Retaining Bolts	17	23	2.3
Air Cleaner Hose Clamps	1.5	2.0	0.2
Air Cleaner Restriction Indicator Switch	9	12	1.2
Injector Nozzle Retaining Nut	50	70	7.0
Injector Retaining Bolts	17	22	2.2
Injector Leak-Off Line Banjo Bolts	8	12	1.2
High Pressure Gland Nuts, at Injector and Fuel Injection Pump	18	24	2.4
Fuel Tank Drain Valve	5	7	0.7

