

Section 2.1 - Basic Engine Mechanical

- 2.1.1- Tightening Cylinder Head Bolts
- 2.1.2- Tightening Manifold, Exhaust Tube and Carburetor Fasteners
- 2.1.3- Adjusting Valve Clearance
- 2.1.4- Checking Drive Belts
- 2.1.5- Measuring Compression Pressure

Section 2.2 - Timing Belt Removal, Inspection & Installation

- 2.2.1- Timing Belt Precautions
- 2.2.2- Timing Belt Removal
- 2.2.3- Timing Belt Inspection
- 2.2.4- Timing Belt Installation

Section 2.3 - Cylinder Head

- 2.3.1- Cylinder Head Removal
- 2.3.2- Disassembly
- 2.3.3- Check Cylinder Head Distortion
- 2.3.4- Valve Guide Clearance
- 2.3.5- Valve Guide Replacement
- 2.3.6- Valve Inserts
- 2.3.7- Camshaft Bearing Clearance
- 2.3.8- Camshaft Runout
- 2.3.9- Valve Dimensions
- 2.3.10- Valve Spring Squareness, Free Length and Tension
- 2.3.11- Cylinder Head Assembly
- 2.3.12- Installation

PART 2

ENGINE MECHANICAL

Section 2.4 - Oil Pan and Oil Pump

- 2.4.1- Removal
- 2.4.2- Inspection

Section 2.5 - Oil Seal Replacement

- 2.5.1- Replacement of Camshaft Oil Seal
- 2.5.2- Replacement of Crankshaft Front Oil Seal

Section 2.6 - Engine Overhaul

- 2.6.1- Disassembly
- 2.6.2- Inspection
- 2.6.3- Assembly

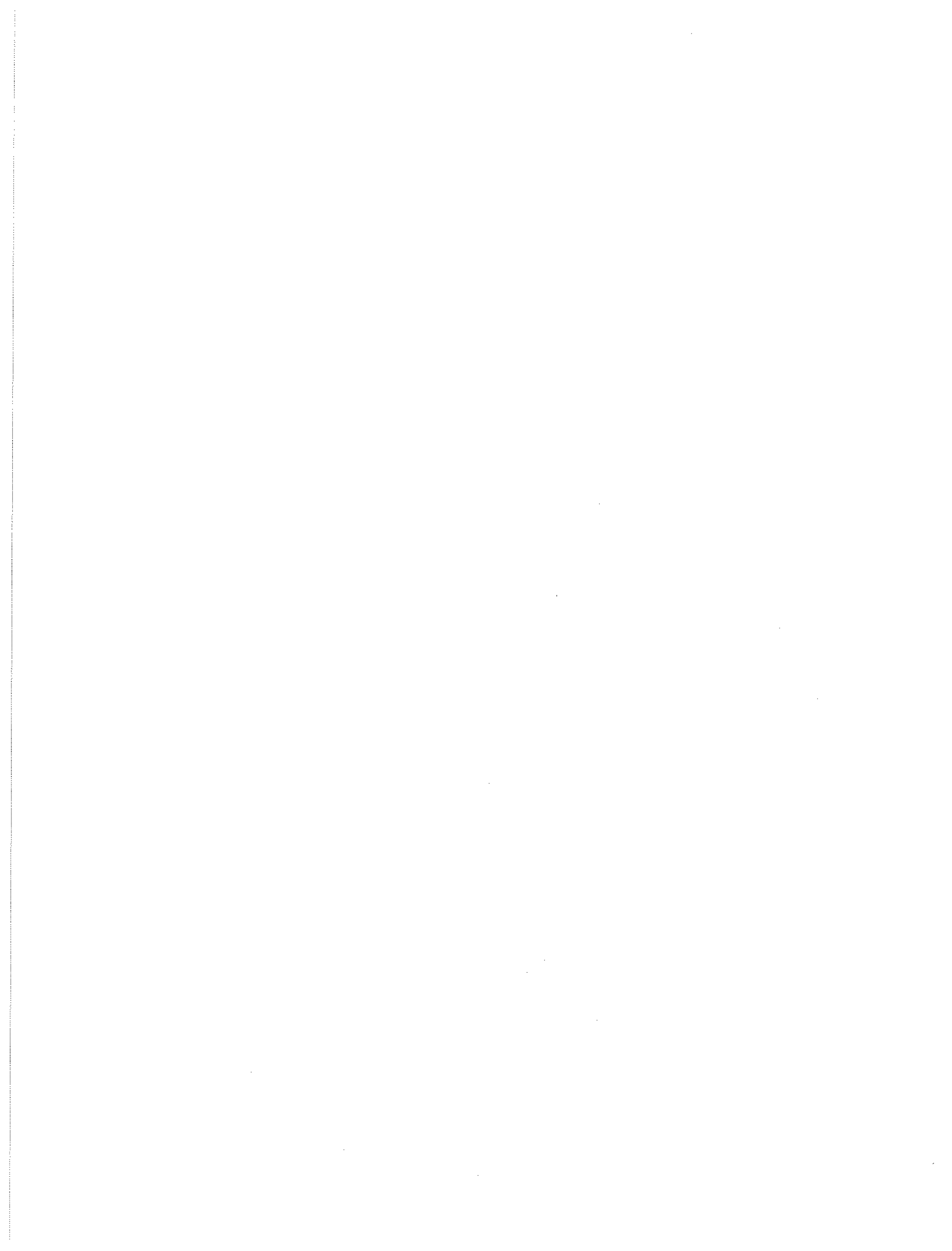

SECTION 2.1 - BASIC ENGINE MECHANICAL

2.1.1- Tightening Cylinder Head Bolts

Retighten cylinder head bolts while engine is cold (approximately 68° F. (20° C.)), as follows:-

A Remove all spark plugs, oil pump drive gears, retainer and bolts.

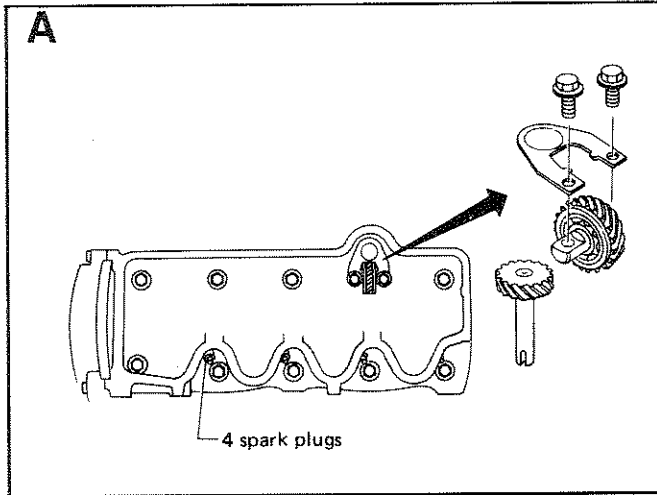

B Retighten bolts in the sequence shown. Tighten to 47-51 foot-pounds (64-69 N-m).

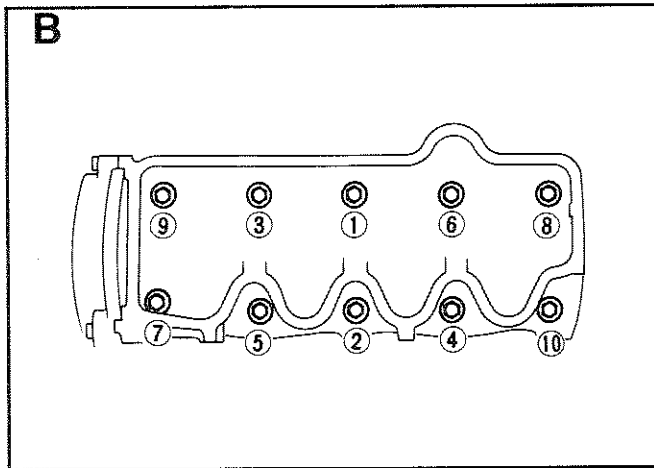

2.1.2- Tightening Manifold, Exhaust Tube and Carburetor Fasteners

Intake Manifold Nuts:- 12-15 foot-pounds (16-21 N-m)

Exhaust Tube Nuts:- 22-26 foot-pounds (29-35 N-m)

Carburetor Bolts:- 4.3-5.8 foot-pounds (6-8 N-m)

2.1.3- Adjusting Valve Clearance

Adjust valves while engine is warm but not running, as follows:-

C Set No. 1 cylinder at top dead center (TDC) of its compression stroke and adjust valve clearance 1, 2, 3 and 6. Then, set No. 4 cylinder at top dead center (TDC) of its compression stroke and adjust valve clearance 4, 5, 7 and 8. Set valve clearance as follows:-

Valve Clearance HOT

INTAKE - 0.010 inch (0.25mm)

EXHAUST - 0.012 inch (0.30mm)

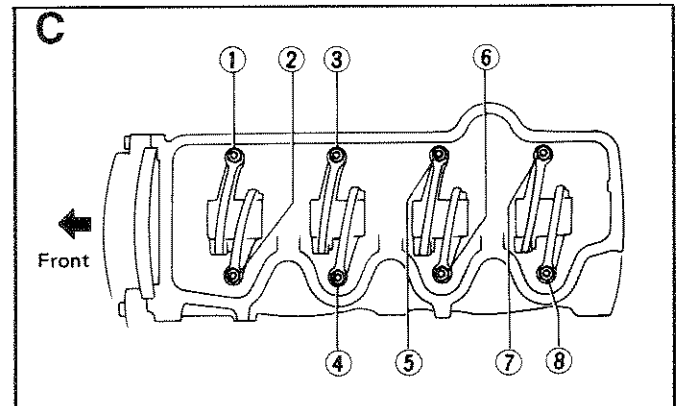

D When valve clearance is properly set, tighten the adjusting screw locknut to 8-11 foot-pounds (11-15 N-m).

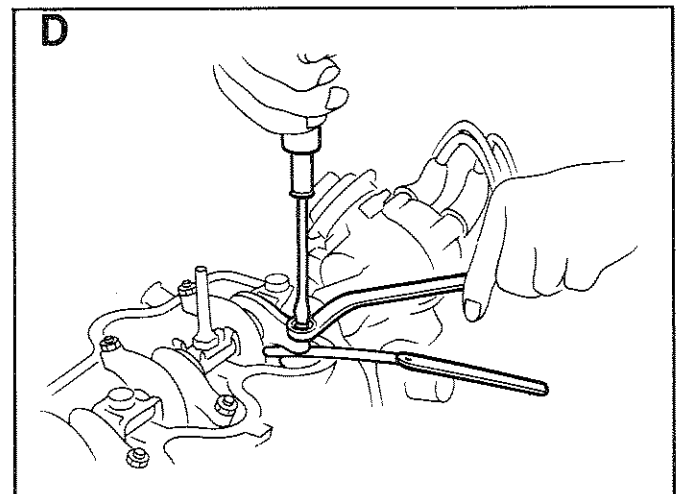

2.1.4- Checking Drive Belts

E Inspect for cracks, fraying, wear or oiliness. Replace, if necessary. The belts should not touch bottom of pulley groove. Belt tension is correct when a force of about 22 pounds, (10 kg) applied midway between pulleys, results in a belt deflection of about 1/2-3/4 inch (12.7-19.0mm).

2.1.5- Measuring Compression Pressure

F Warm up engine. Then, shut down and remove all spark plugs. Use a standard automotive type engine compression tester. Hold throttle and choke valves on carburetor fully open, then crank engine and read the compression pressure. Compression pressure should be as follows:

STANDARD - 192 psi (13.5 kg/cm²) at 350 rpm

MINIMUM - 164 psi (11.5 kg/cm²) at 350 psi

DIFFERENCE BETWEEN CYLINDERS SHOULD NOT EXCEED 14 PSI (1.0 kg/cm²)

If compression is low in any cylinder(s), pour a small amount of clean engine oil into cylinders through the spark plug opening. Then, retest compression and evaluate as follows:

- * If compression pressure increased after adding oil, check for worn or damaged piston rings.
- * If pressure did NOT increase after adding oil, valve(s) may be sticking or seating improperly.
- * If compression in any two adjacent cylinders is low and adding oil did not increase the compression, check for a leaking head gasket.

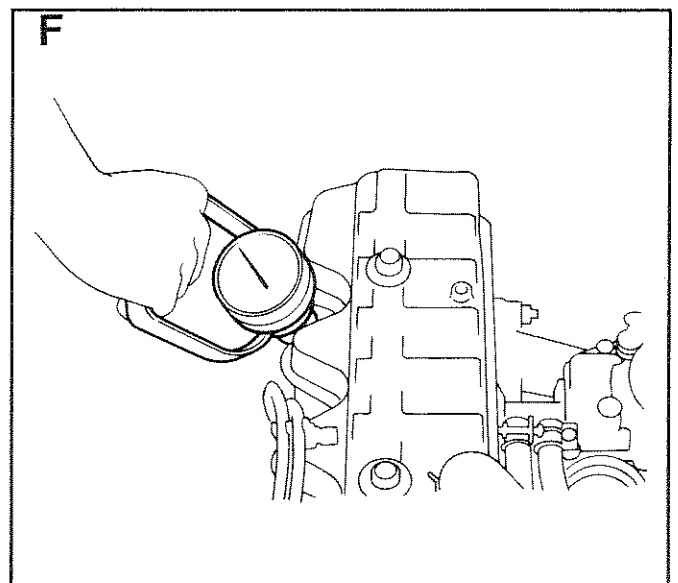
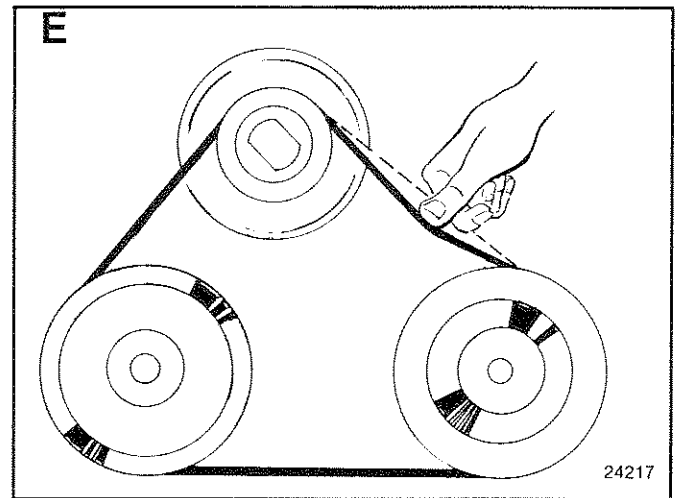

SECTION 2.2 - TIMING BELT REMOVAL, INSPECTION & INSTALLATION

2.2.1- Timing Belt Precautions

Comply with the following precautions when removing, inspecting or installing the timing belt:

- * Check that the timing belt, pulleys and tensioner are free from oil and water.
- * Prior to installing the timing belt, make sure that No. 1 cylinder is set at top dead center (TDC) of its compression stroke.
- * Align the arrow on the timing belt in the direction of engine rotation.
- * Remove all spark plugs before adjusting timing belt tension.
- * When timing belt is removed, do NOT rotate crankshaft and camshaft separately (valves will strike the piston heads).
- * DO NOT bend or twist the timing belt too tightly.

2.2.2- Timing Belt Removal

A Remove BELT GUARD.

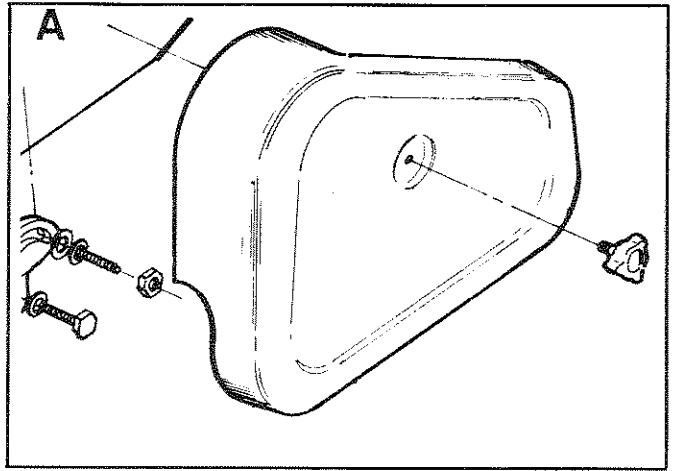

TIMING BELT AND RELATED COMPONENTS

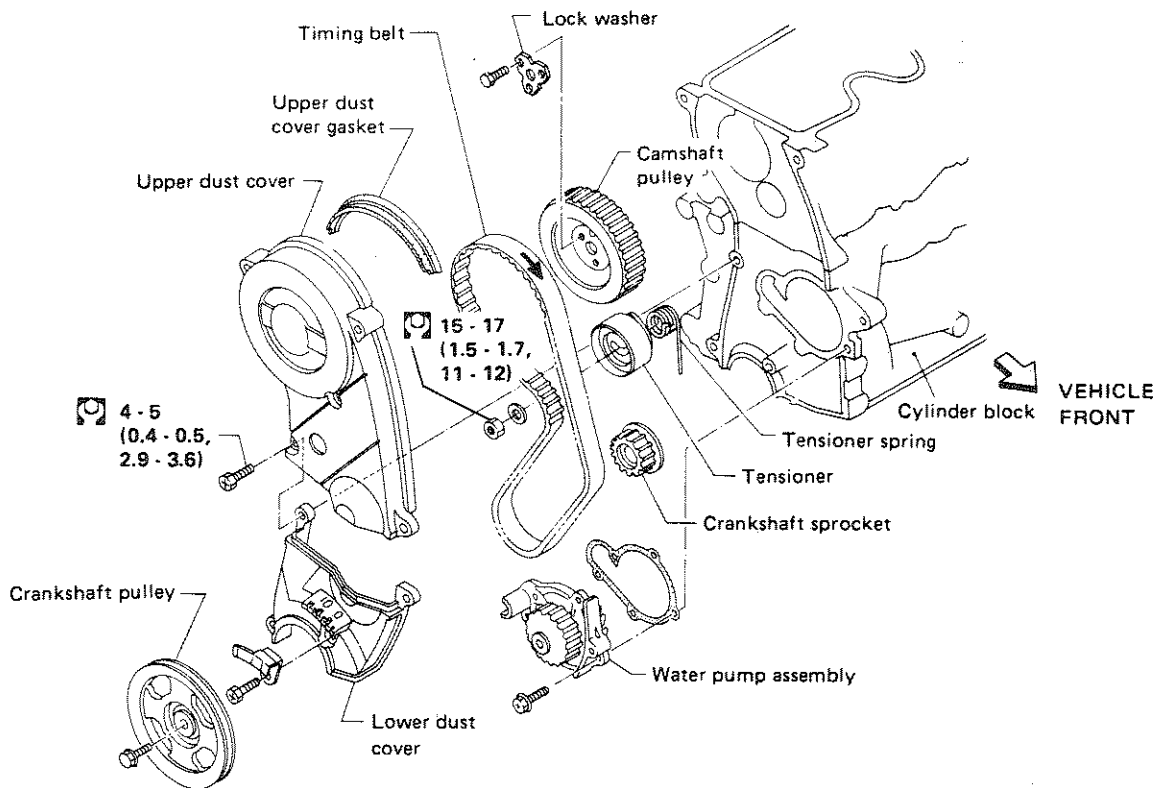

B Loosen tension on drive belt by loosening sea water pump tensioning bolt. Remove Drive Belt.

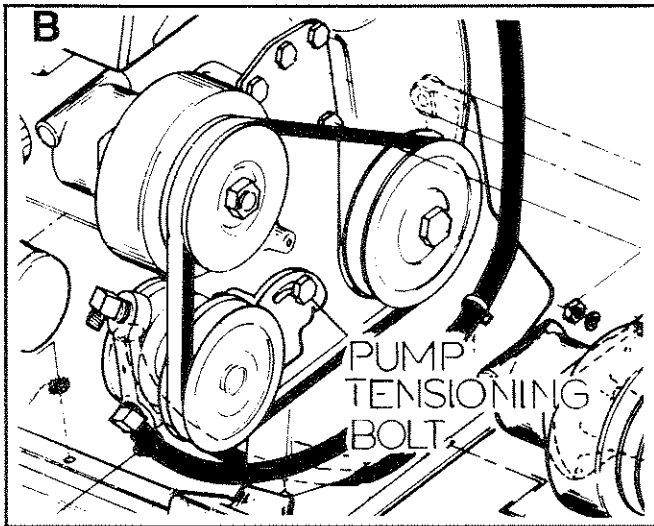

C Remove Crankshaft Pulley.

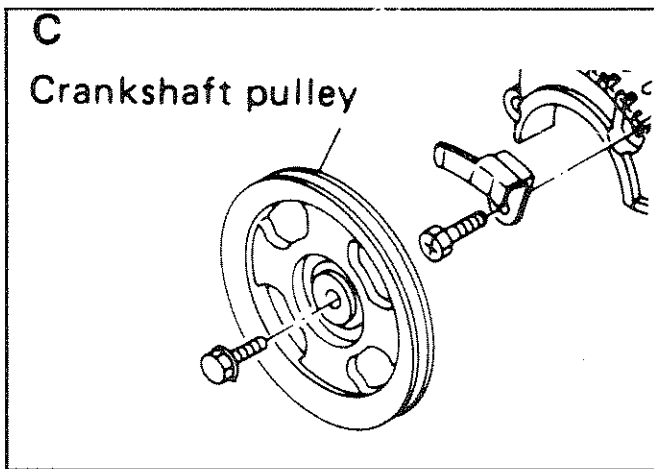

D Set No. 1 cylinder at top dead center (TDC) of its compression stroke. Then, remove upper and lower dust covers and gaskets. Loosen timing belt tensioner and return spring, then remove timing belt.

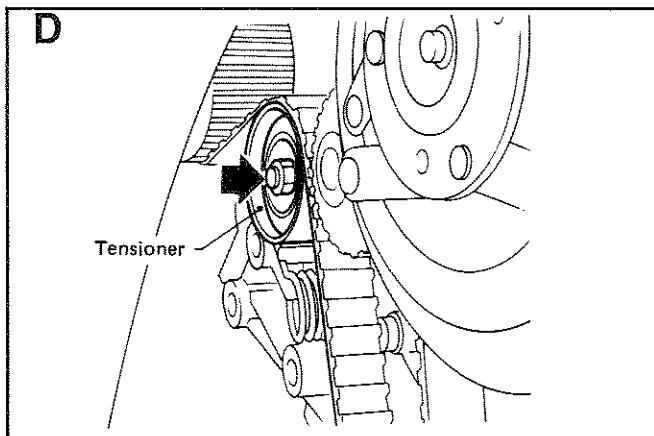

2.2.3- Timing Belt Inspection

E Belt Is Broken: Caused by improper handling, poor belt cover sealing, coolant leakage at water pump.

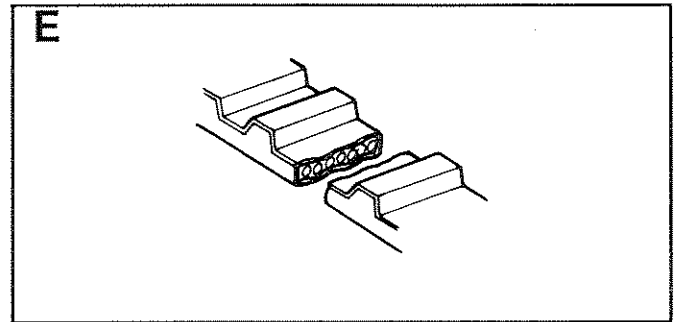

F Tooth Broken or Tooth Root Cracked: Caused by camshaft jamming, distributor jamming, damaged crankshaft or camshaft oil seal.

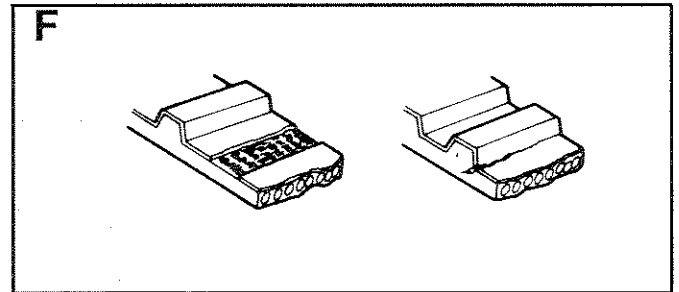

G Back Surface is Cracked/Worn: Caused by tensioner jamming, overheated engine, interference with belt cover.

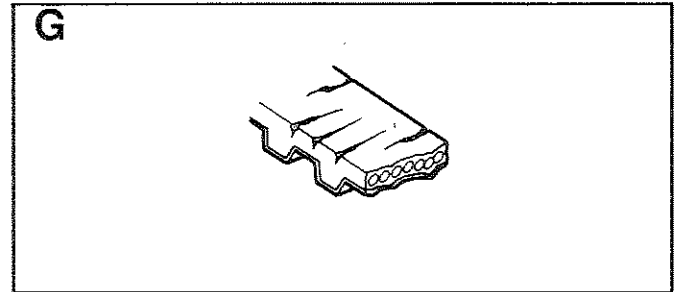

H Side surface Worn: Caused by improper belt installation, defective crank pulley and/or timing belt plate.

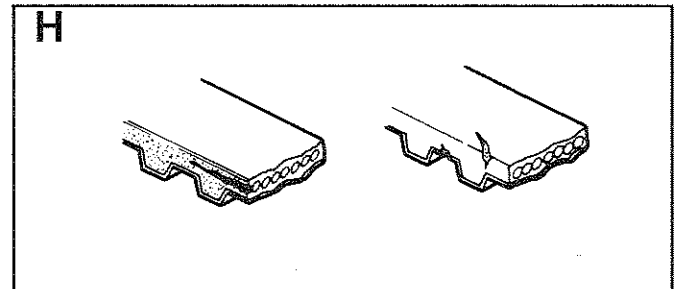

J Belt Teeth are Worn: Caused by poor belt cover sealing, coolant leakage at water pump, defective camshaft, defective distributor, excessive belt tension.

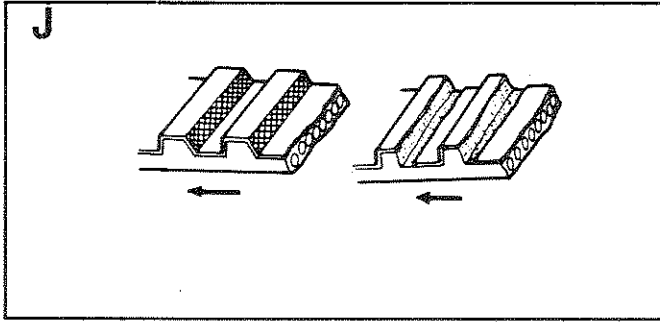

2.2.4- Timing Belt Installation

K Check that No. 1 cylinder is at top dead center (TDC) of its compression stroke. Align camshaft and crankshaft pulley marks.

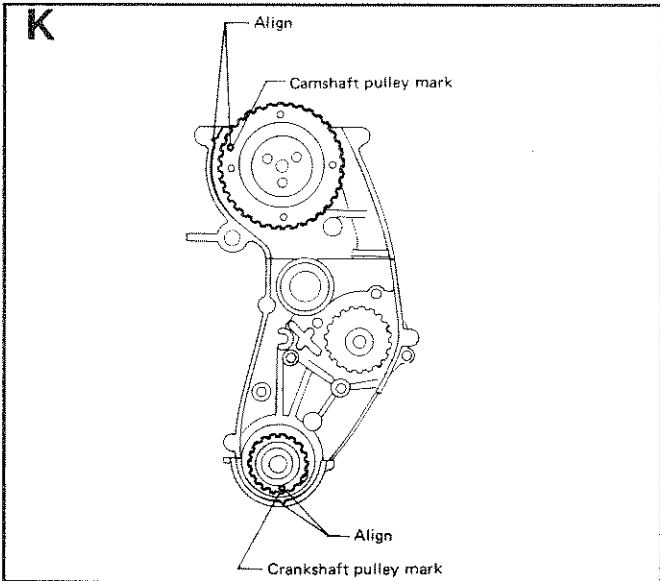

L Install tensioner and return spring. Hook the return spring to its stopper.

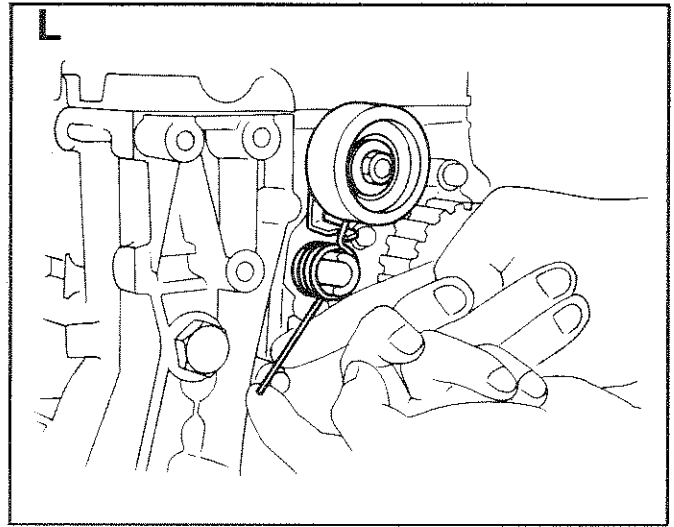

M Slide the tensioner to the left and tighten lock nut temporarily.

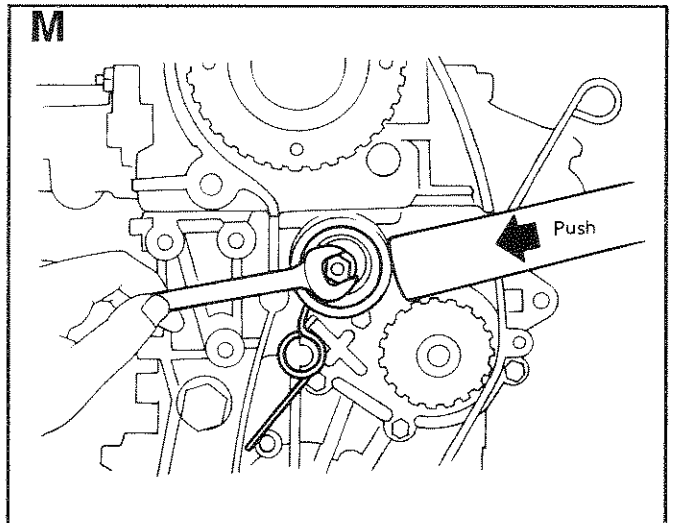

N Check that the water pump and tensioner pulleys can be rotated smoothly, with no evidence of binding. Install timing belt.

IMPORTANT: Make sure timing belt is clean and free of oil and water. Do not bend the belt. Arrow on belt must point in normal direction of rotation.

Loosen tensioner lock nut. With all spark plugs removed, rotate camshaft pulley two full turns counterclockwise. Tighten the tensioner lock nut. Finally, check belt tension.

With force of 1.06-1.28 pounds applied, belt should deflect about 0.08 inch (2mm).

Tighten tensioner lock nut to 11-12 foot-pounds (15-17 N-m).

N

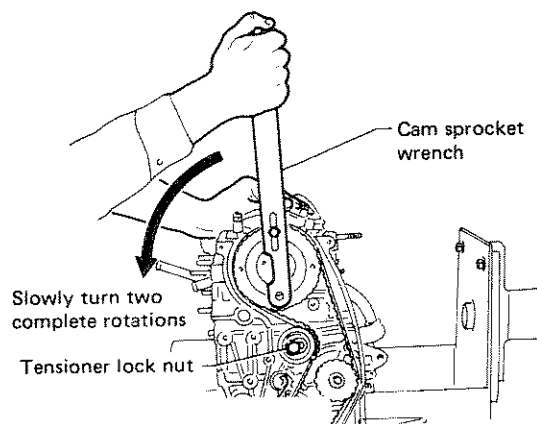

SECTION 2.3 - CYLINDER HEAD

2.3.1- Cylinder Head Removal

A Remove timing belt (Section 2.2). Then, remove OIL PUMP IDLER GEAR.

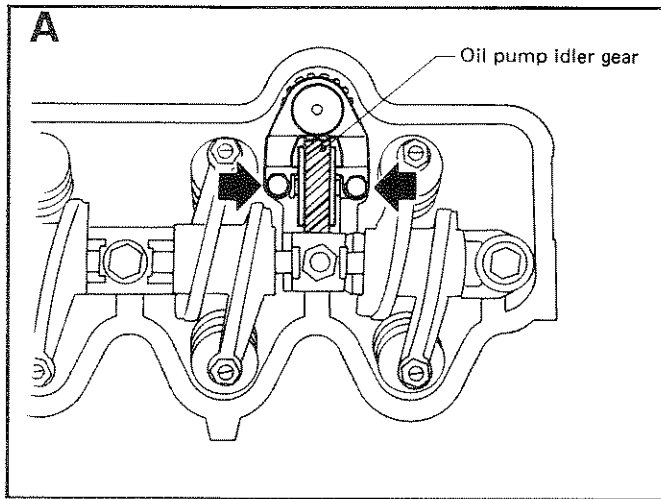

B Remove cylinder head. Loosen bolts in the sequence shown.

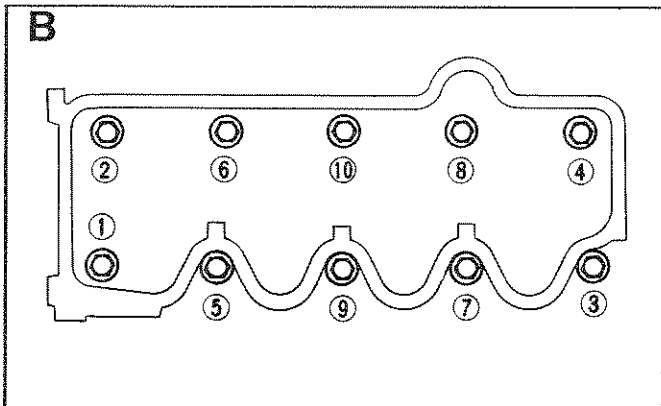

C If cylinder head is hard to separate, pry with a screwdriver.

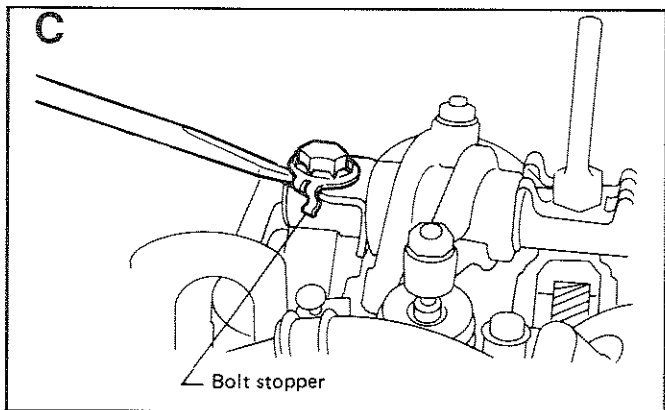

2.3.2- Disassembly

D Remove bolt lock tabs and rocker shaft with rocker arms. KEEP THEM IN PROPER ORDER.

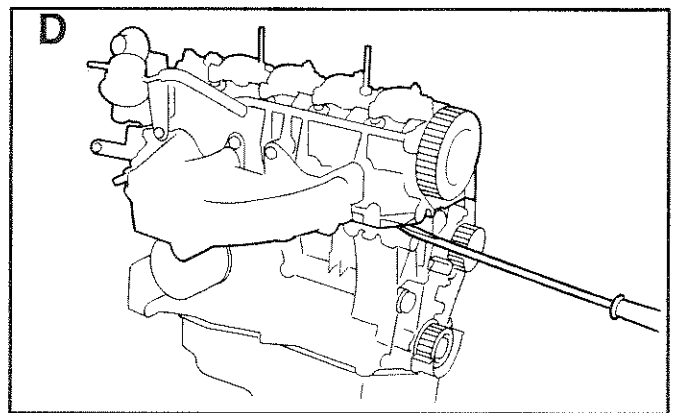

E Remove camshaft.

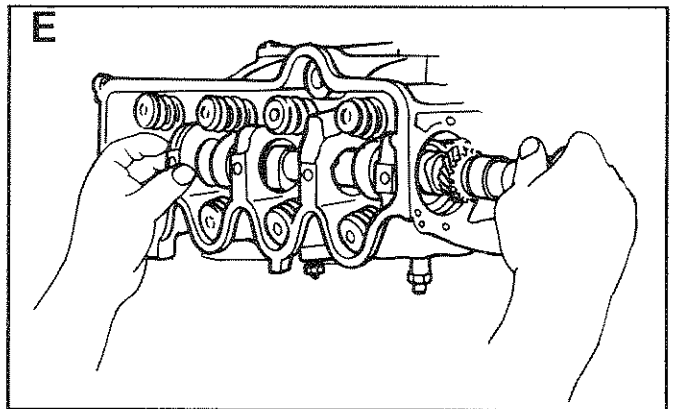

F Remove valve component parts, using suitable tool.

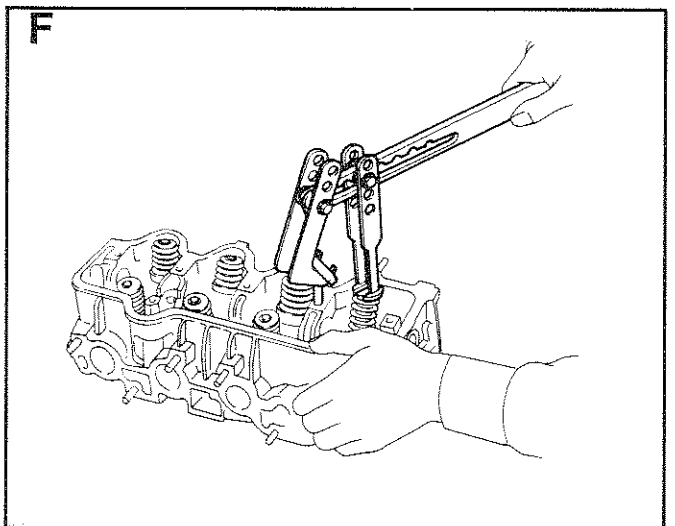

ENGINE CYLINDER HEAD

- When installing sliding parts such as bearings, be sure to apply engine oil on the sliding surfaces.
- Use new gaskets and oil seals.
- When installing Welch plug, apply sealant.

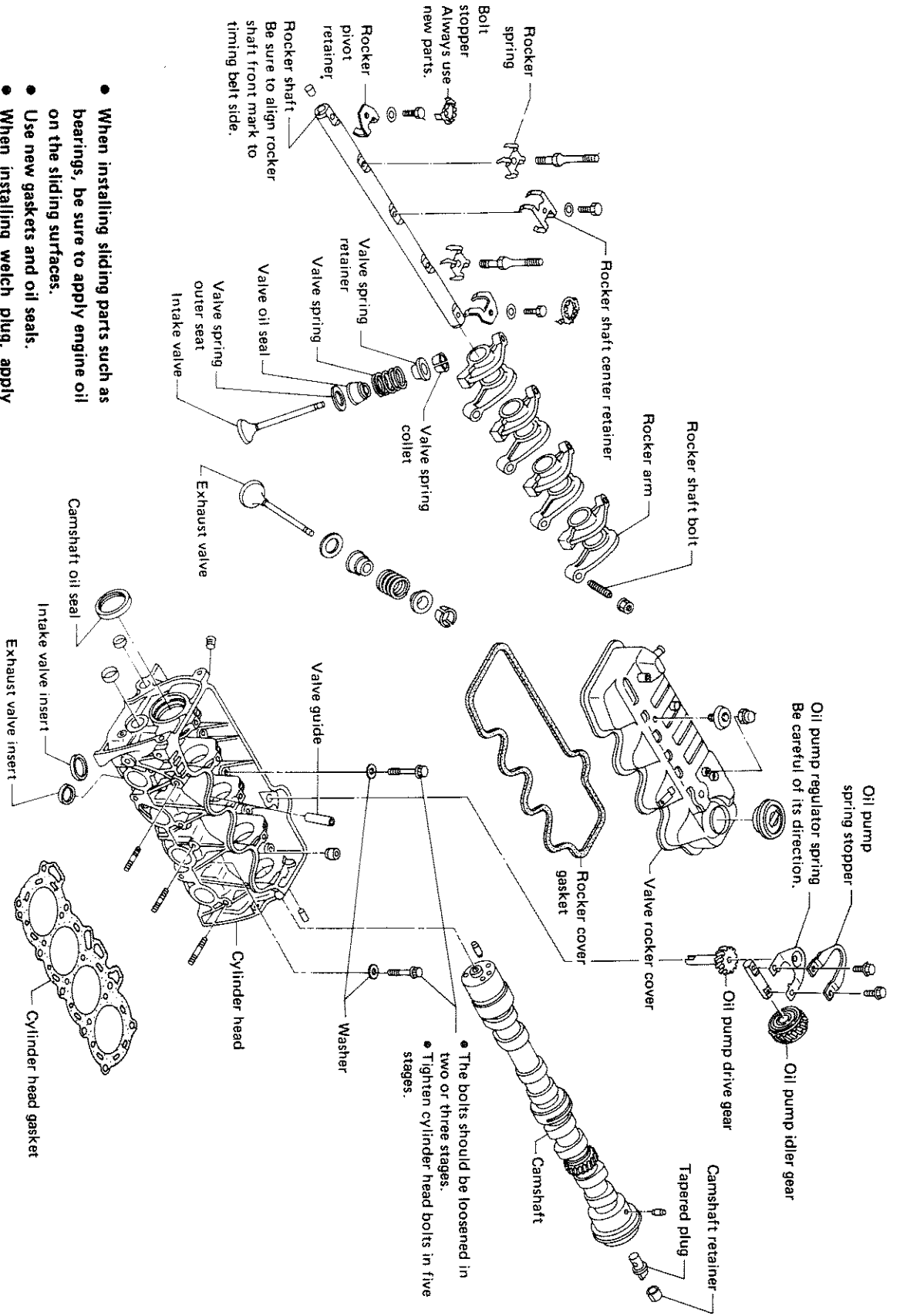

G Remove valve oil seals, using suitable puller.

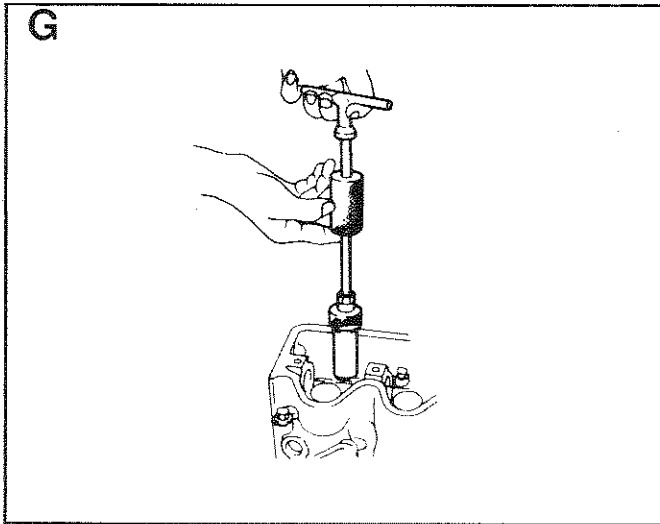

2.3.3- Check Cylinder Head Distortion

H Use a thickness gauge and straightedge to measure cylinder head distortion. Lay the straightedge across the cylinder head surface as shown. Surface warpage must not exceed 0.004 inch (0.1mm). If surface warpage exceeds the stated value, cylinder head may be resurfaced.

Resurfacing Limit:- The amount of resurfacing that can be done on the cylinder head depends on the amount of resurfacing on the cylinder block. If the amount of HEAD resurfacing is "A" and the amount of BLOCK resurfacing is "B", the maximum limit is as follows:

$$A + B = 0.008 \text{ inch (0.2mm)}$$

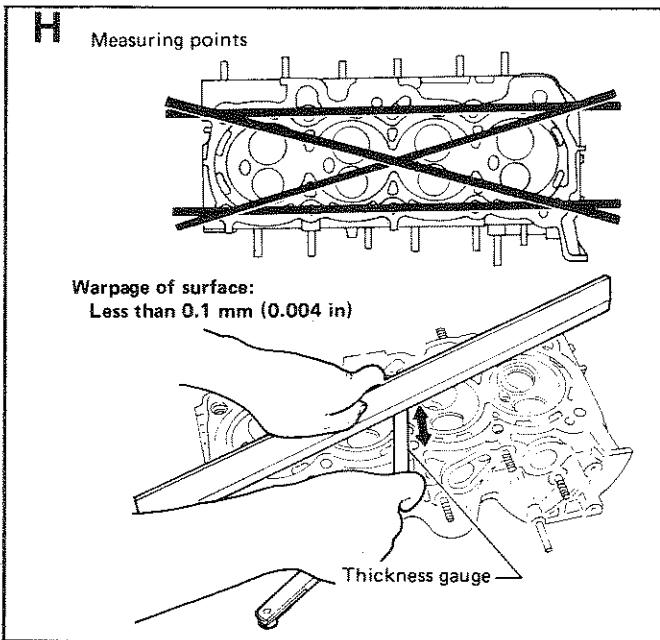

2.3.4- Valve Guide Clearance

J Use a suitable dial indicator to measure valve stem to guide clearance. Valve should be moved parallel to the rocker arm, since most of the wear occurs in this direction. See illustration for maximum limits.

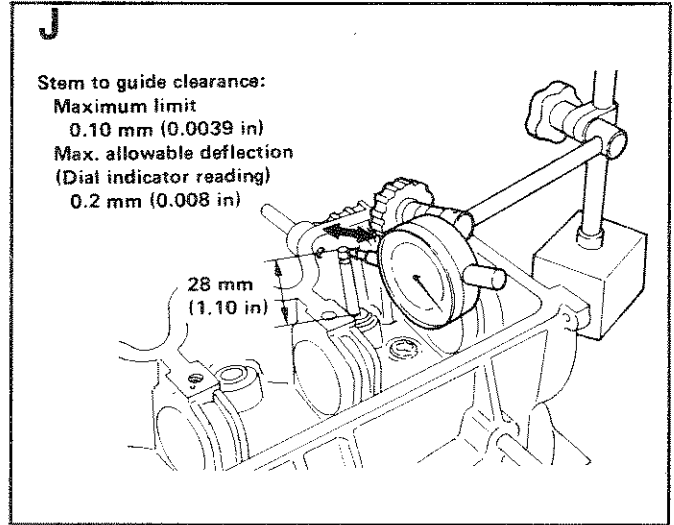

2.3.5- Valve Guide Replacement

K Heat cylinder head to 302°-320° F. (150°-160° C.).

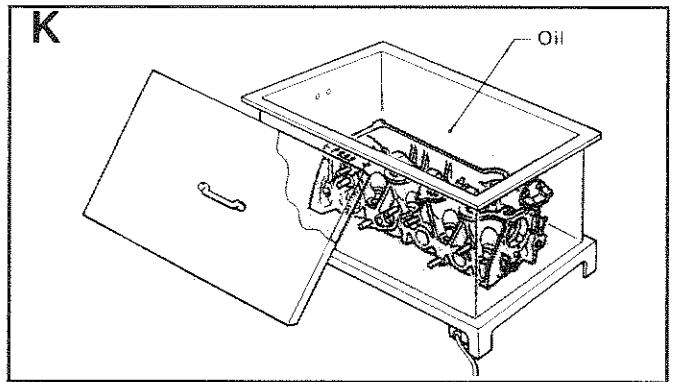

L Press valve guide out with a press, using a 2.2 U.S. ton (20 kN) force. If press is not available, use a hammer and suitable driving tool.

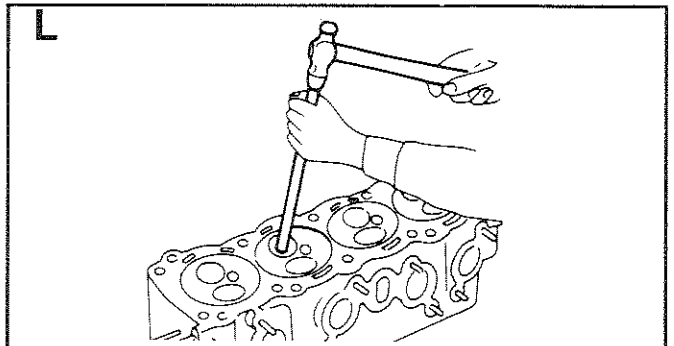

M Ream cylinder head valve guide hole.

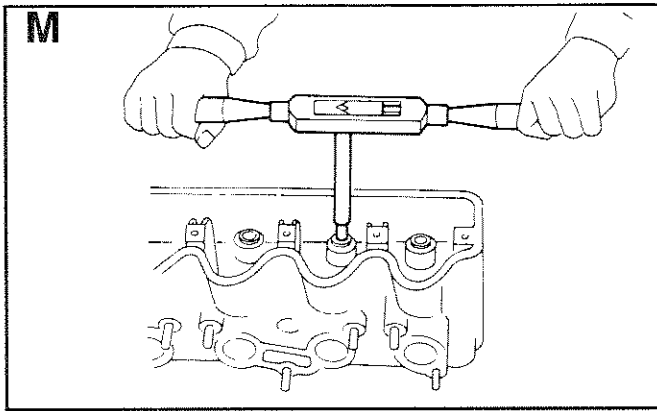

N Heat cylinder head to 302°-320° F. (150°-160° C.), then press service valve guide onto cylinder head.

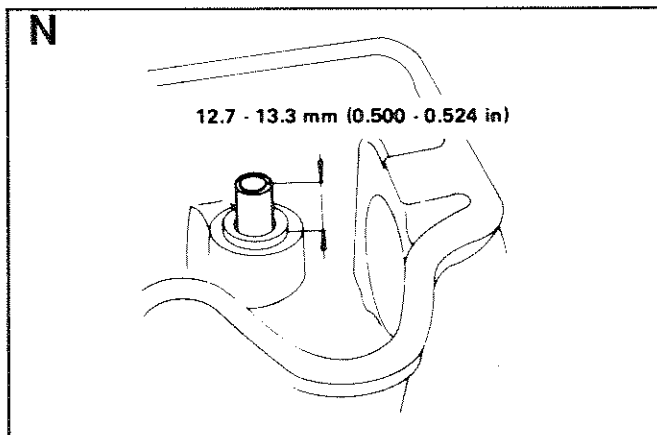

O Ream valve guide to finished size of 0.2758-0.2764 inch (7.005-7.020mm).

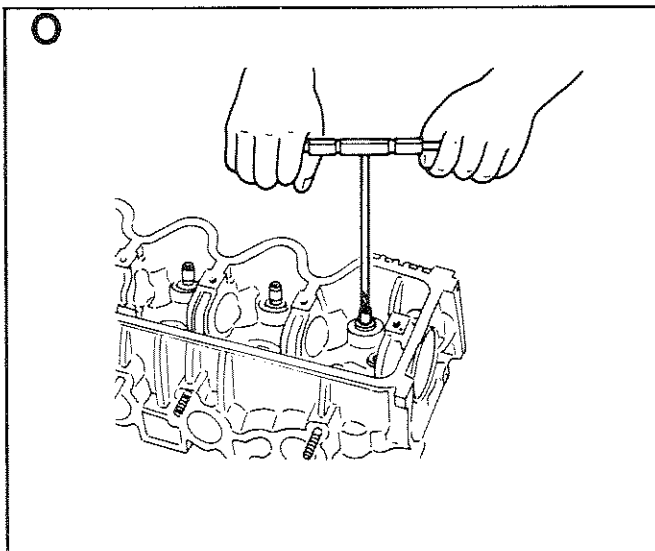

2.3.6- Valve Inserts

P Check valve inserts for evidence of pitting at valve contact surface. Reseat or replace, if worn excessively. The following rules apply:

- * When repairing valve inserts, first check valve and valve guide for wear. If worn, replace them. Then, correct valve seat.

- * Cutting should be done with both hands, for more uniform cutting.

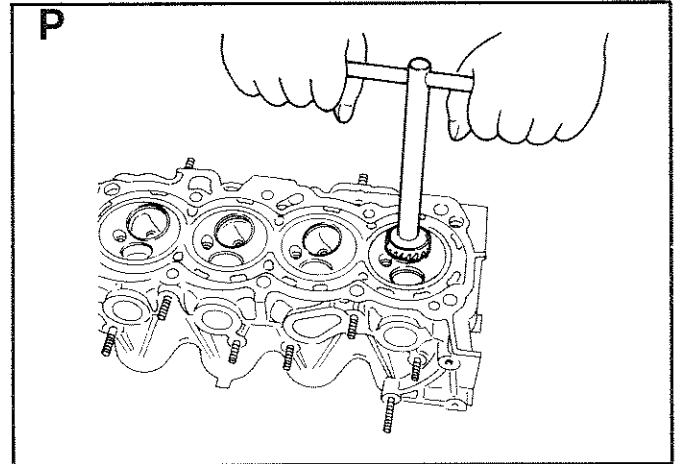

If necessary, replace valve inserts as follows:

- Ream the cylinder head recess.
- Heat cylinder head to 302°-320° F. (150°-160° C.).
- Install insert. Make sure it bends at bottom face of its recess and caulk at more than 4 places.
- Newly fitted valve seats should be ground with a suitable tool, to the specifications listed in the applicable SPECIFICATIONS chart.
- Apply a small amount of valve grinding compound to valve contacting face and place valve into guide.

2.3.7- Camshaft Bearing Clearance

Q Check camshaft bearing clearance as shown. Maximum clearance between bearing and its bore is 0.0059 inch (0.15mm).

R Check bore and check bearing outside diameter. Difference between them is bearing clearance.

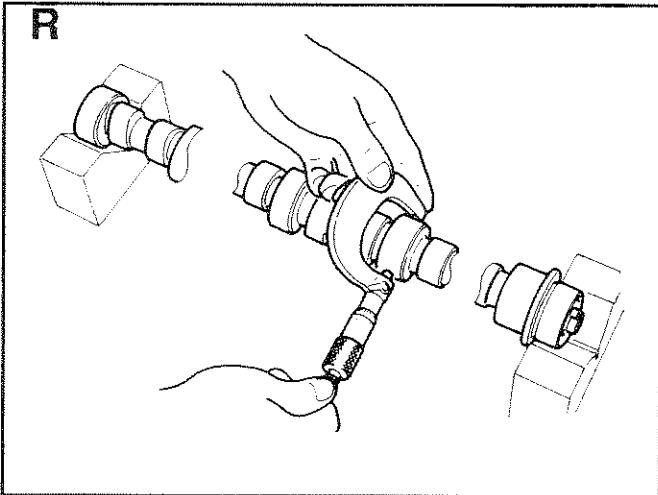
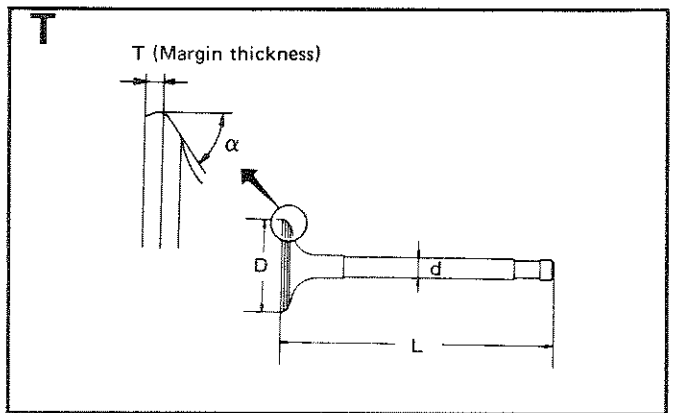
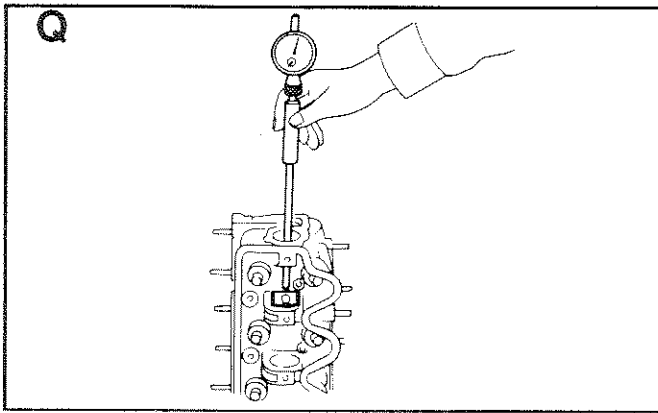

When valve head is worn to 0.020 inch (0.5mm) margin thickness, replace the valve. Grinding allowance for valve stem end surface is 0.008 inch (0.2mm) or less.

2.3.10- Valve Spring Squareness, Free Length and Tension

U Valve spring out-of-squareness must not exceed 0.079 inch (2.0mm). Refer to applicable SPECIFICATIONS chart for spring free length and tension.

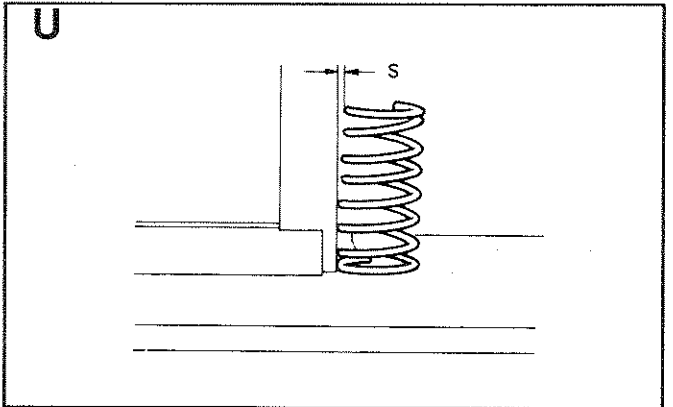

2.3.8- Camshaft Runout

S Use a suitable measuring device to check camshaft runout.

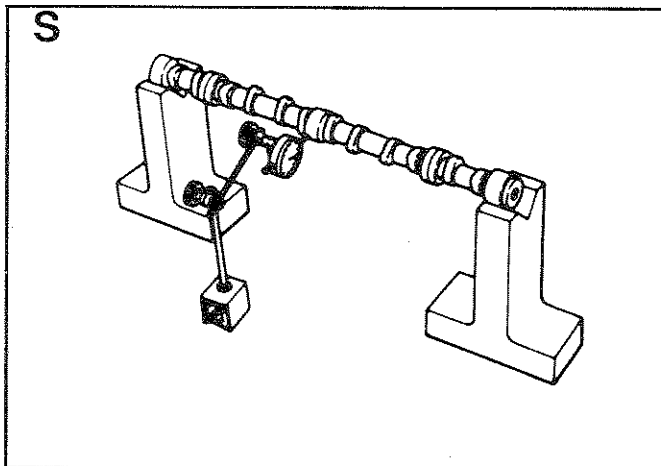

2.3.11- Cylinder Head Assembly

V Install valve oil seal. Then, install valve components parts. Apply engine oil to camshaft oil seal and install the seal.

W Install camshaft assembly. Note positioning of camshaft front face when No. 1 cylinder is set at top dead center (TDC) of its compression stroke.

2.3.9- Valve Dimensions

T Check dimensions of all valves. Refer to applicable SPECIFICATIONS chart.

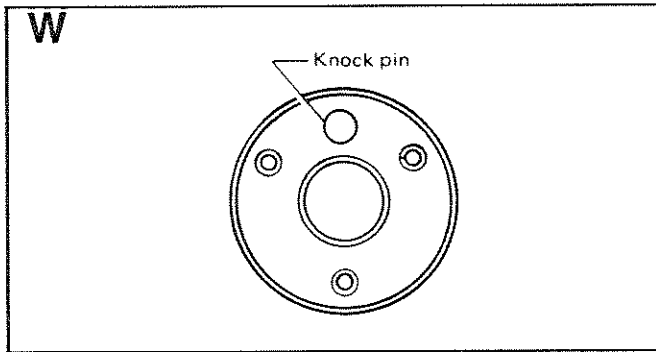
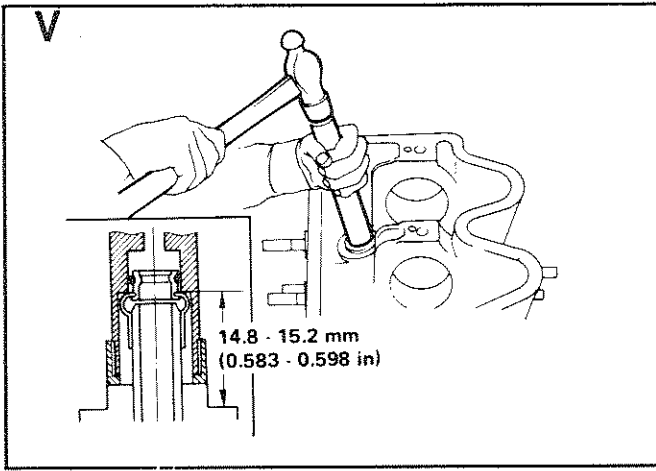

X Measure camshaft end play with thermostat housing and gasket installed.

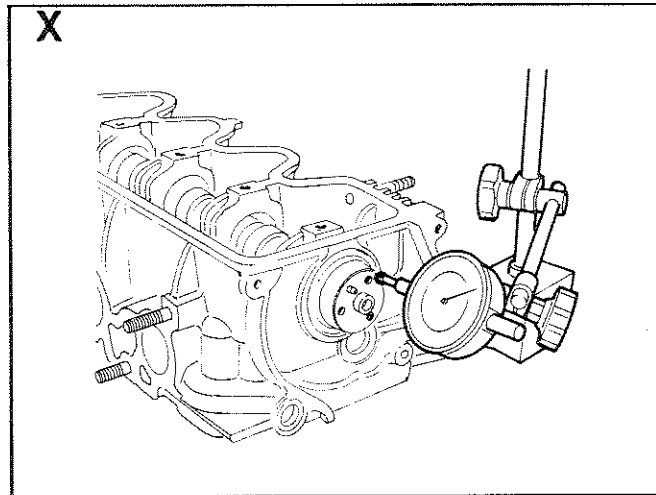

Y Install Rocker Shaft with Rocker Arms.

Z Attach bolt stoppers. ALWAYS USE NEW BOLT STOPPERS.

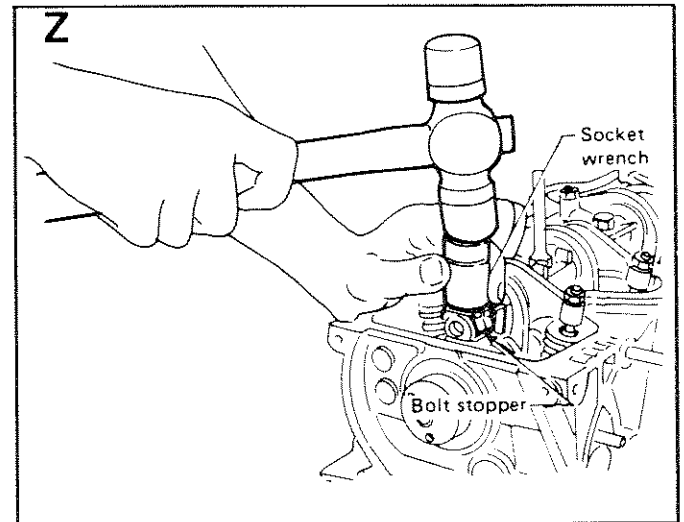
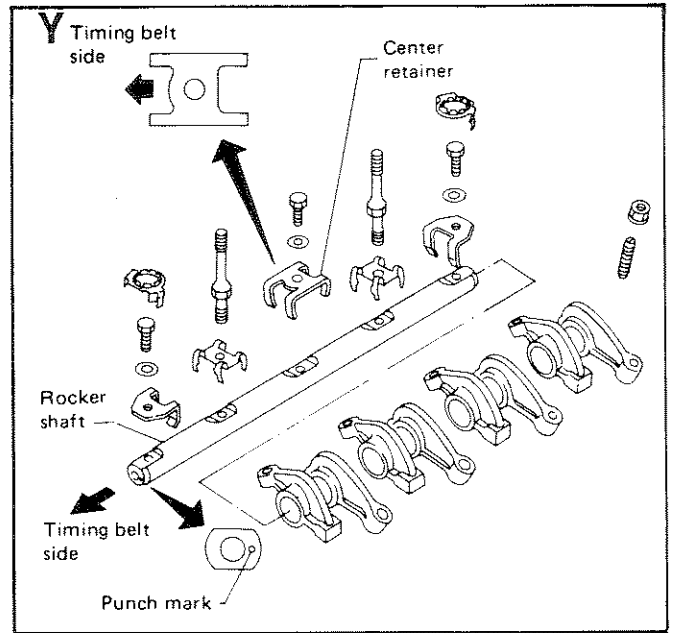

AA Install oil pump idler gear and oil pump regulator spring. Make sure spring faces in the proper direction.

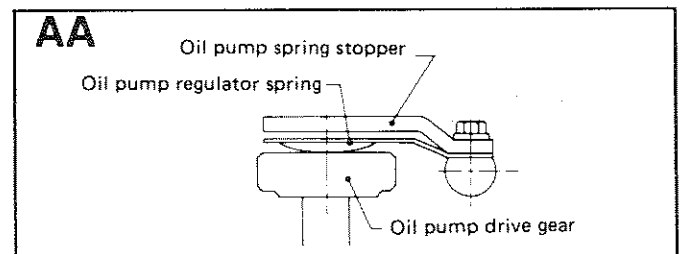

2.3.12- Installation

BB Set No. 1 cylinder at TDC of its compression stroke by first aligning the **CRANKSHAFT TIMING PULLEY MARK** with mark on main bearing cap.

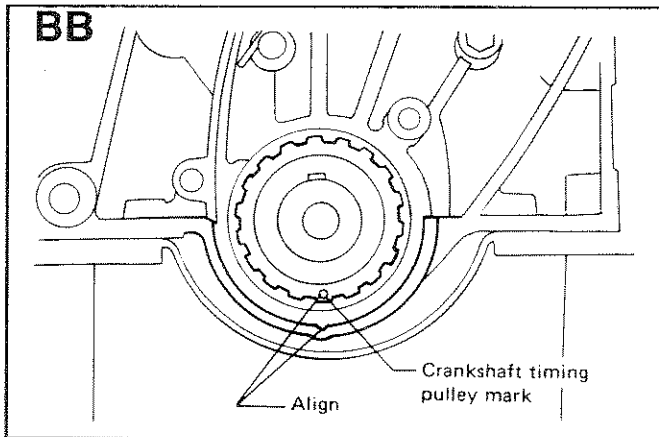

CC Align **CAMSHAFT TIMING PULLEY MARK** with mark on cylinder head.

IMPORTANT: DO NOT ROTATE CRANKSHAFT AND CAMSHAFT SEPARATELY, BECAUSE VALVES WILL HIT PISTON HEADS.

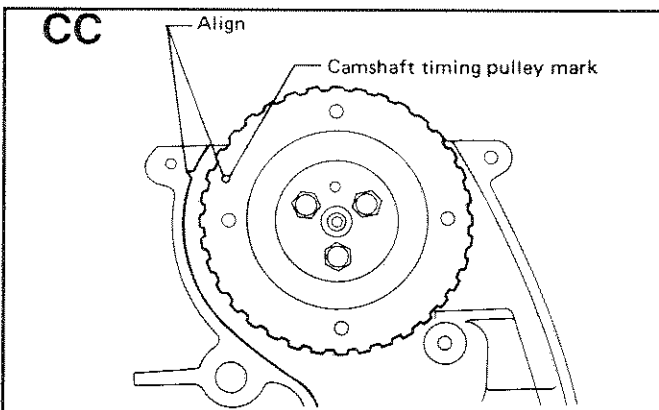

DD Install cylinder head with new gasket.

- * Always use a new cylinder head gasket.
- * Before tightening cylinder head bolts, check that the oil pump drive gear can be turned freely by hand.
- * Always install washers between bolts and head.
- * Tighten cylinder head bolts in the sequence shown in illustration "DD".

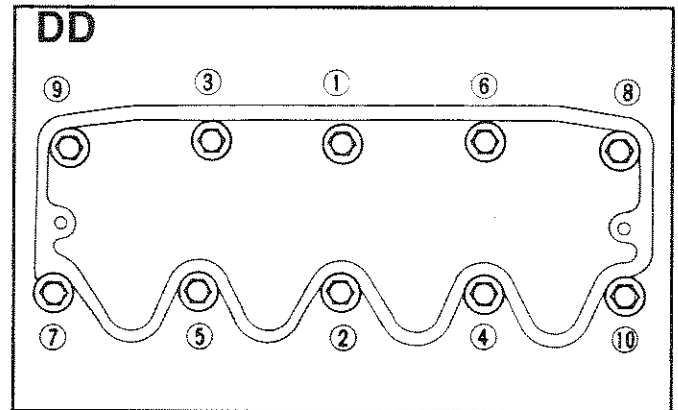

EE Cylinder Head Bolts Tightening Procedure:

- * First, Tighten all bolts to 22 foot-pounds (29 N-m)
- * Then, tighten all bolts to 47 foot-pounds (64 N-m)
- * Loosen all bolts completely.
- * Tighten all bolts to 22 foot-pounds (29 N-m)
- * Tighten all bolts to 47-51 foot-pounds (64-69 N-m).

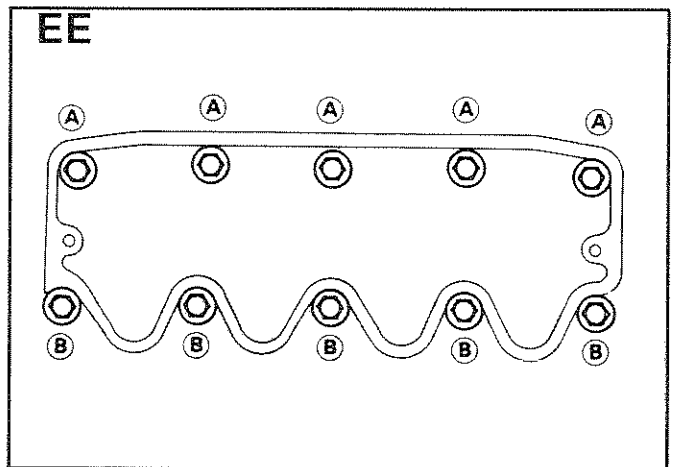

IMPORTANT: When retorquing cylinder head bolts for normal periodic maintenance, first loosen all cylinder head bolts slightly. Then (with engine COLD), tighten all bolts in the correct sequence to 47-51 foot-pounds (64-69 N-m).

FF Install timing belt. Install oil pump idler and oil pump regulator spring. Make sure spring direction is correct. Install **UPPER DUST COVER**, making sure its gasket mates with cylinder head properly.

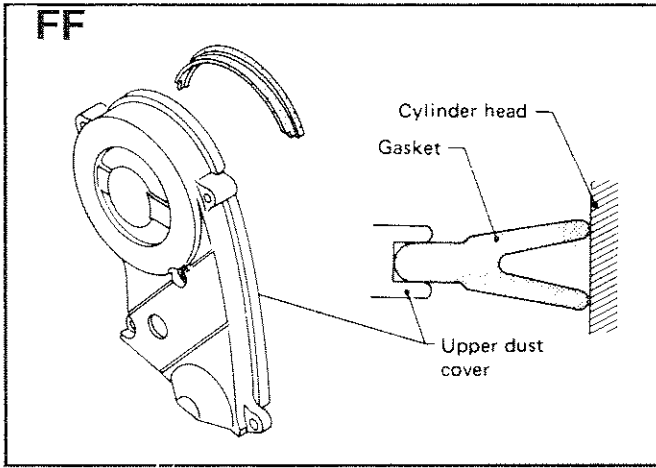

GG Tighten upper dust cover bolts to 2.9-3.6 foot-pounds (4-5 N-m).

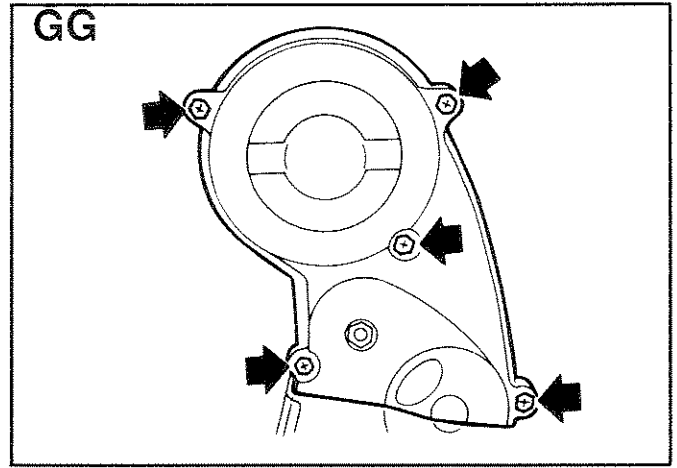

SECTION 2.4 - OIL PAN AND OIL PUMP

2.4.1- Removal

A Drain engine oil. Then, remove oil pump assembly with oil strainer. **BE CAREFUL NOT TO DROP OIL PUMP DRIVE SHAFT.**

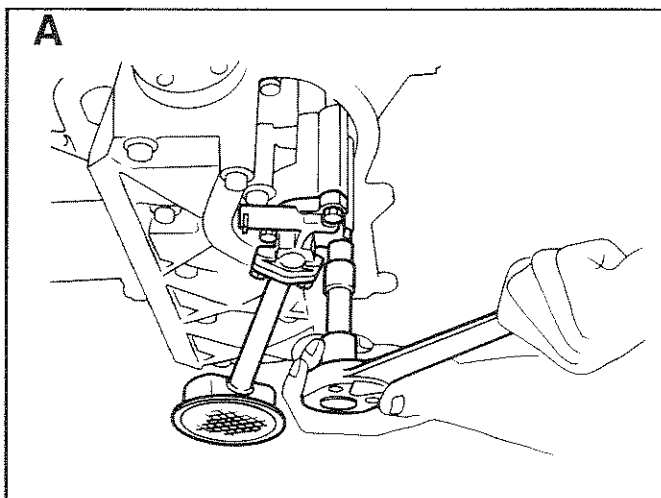

2.4.2- Inspection

Refer to Part 3, ENGINE LUBRICATION AND COOLING SYSTEM.

2.4.3- Installation

Install oil pump assembly and tighten to 13-16 foot-pounds (18-22 N-m).

IMPORTANT: Before tightening oil pump assembly, rotate oil pump drive gear to make sure that pump drive shaft does not interfere with inner wall of cylinder block.

B Apply RTV gasket sealant to oil pan as shown.

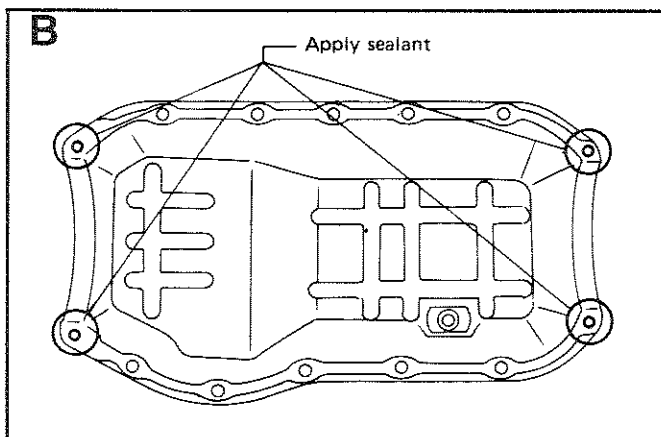

C Install oil seals. Apply RTV sealant to upper and lower surfaces of gaskets as illustrated.

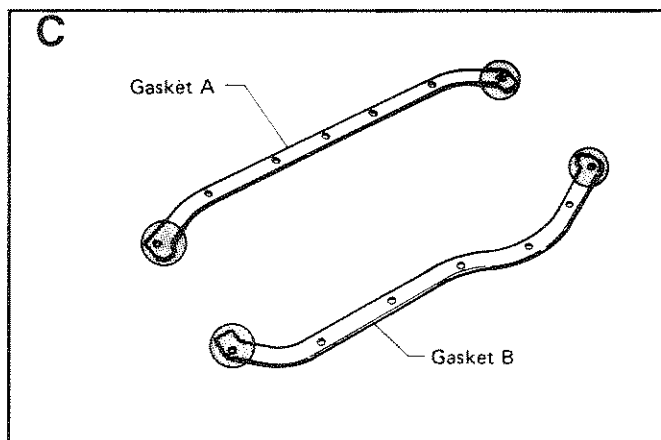

Install gaskets and oil pan. Tighten to 2.9-3.6 foot-pounds (4-5 N-m).

SECTION 2.5 - OIL SEAL REPLACEMENT

2.5.1- Replacement of Camshaft Oil Seal

A Remove timing belt, oil pump idler gear. Remove bolt stoppers and rocker shaft with rocker arms. Remove camshaft. Remove camshaft oil seal. Apply engine oil to new camshaft oil seal and install.

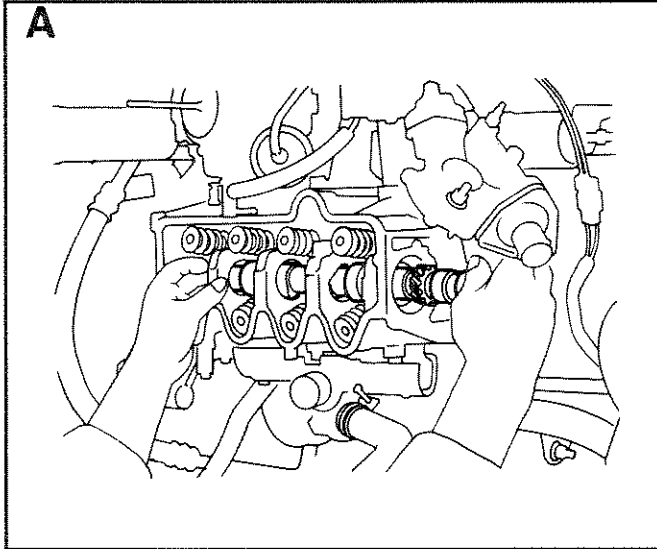

2.5.2- Replacement of Crankshaft Front Oil Seal

B Remove timing belt and cover. Remove oil pan. Remove main bearing caps. Remove crankshaft oil seal. Apply engine oil to new oil seal and install.

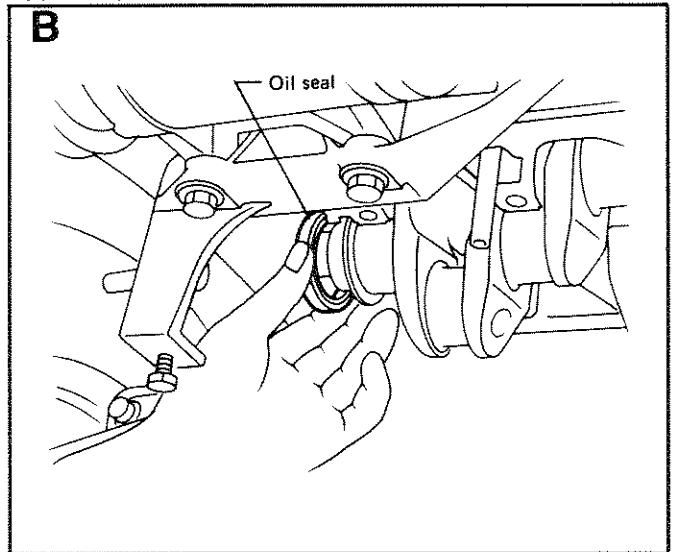

SECTION 2.6 - ENGINE OVERHAUL

2.6.1- Disassembly

A Place engine on workstand. Remove timing belt cover and timing belt. Remove cylinder head and oil pan. Remove pistons.

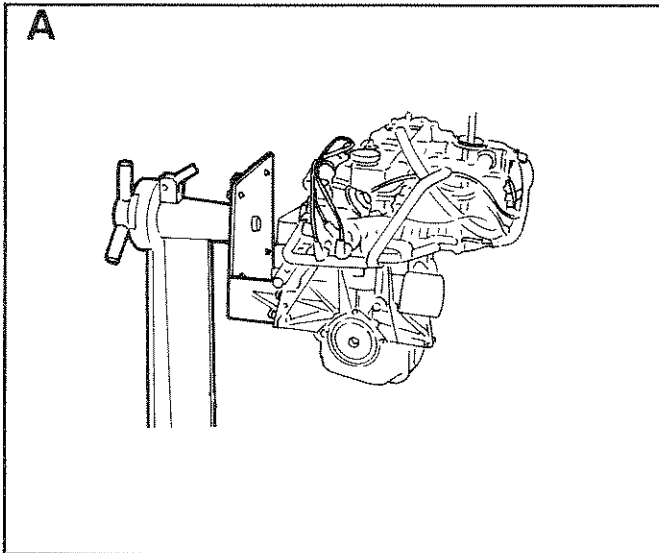

B Remove crankshaft rear oil seal retainer. Remove bearing caps. Finally, remove crankshaft.

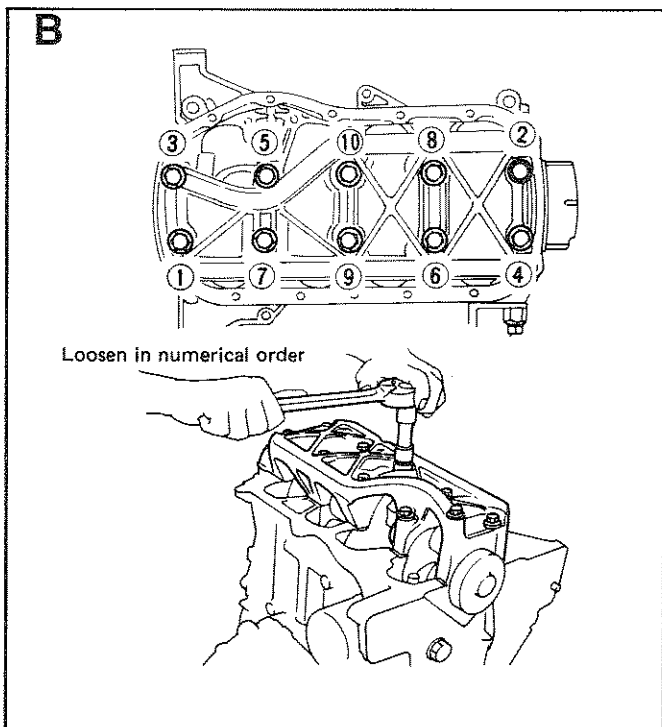

2.6.2- Inspection

C Slide piston pin into piston pin bore. Pin must slide smoothly into bore at room temperature, without side play and without binding.

Piston Pin to Piston Clearance:- 0.0003-0.0005 inch (0.008-0.012mm)

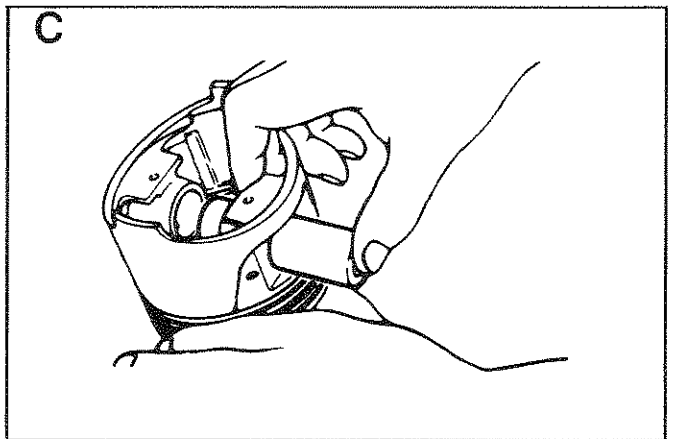

D Check side clearance as shown. Clearance should not exceed the maximum limit stated.

Top Ring0.0016-0.0029 inches (0.040-0.073mm)
Second Ring ...0.0012-0.0025 inches (0.030-0.063mm)
Maximum
Tolerance0.008 inch (0.2mm)

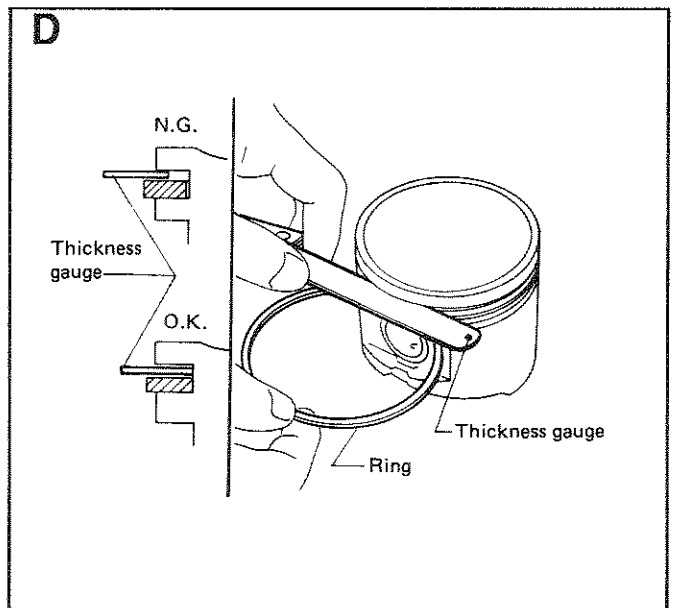

ENGINE OVERHAUL- CYLINDER BLOCK, CRANKSHAFT & PISTON

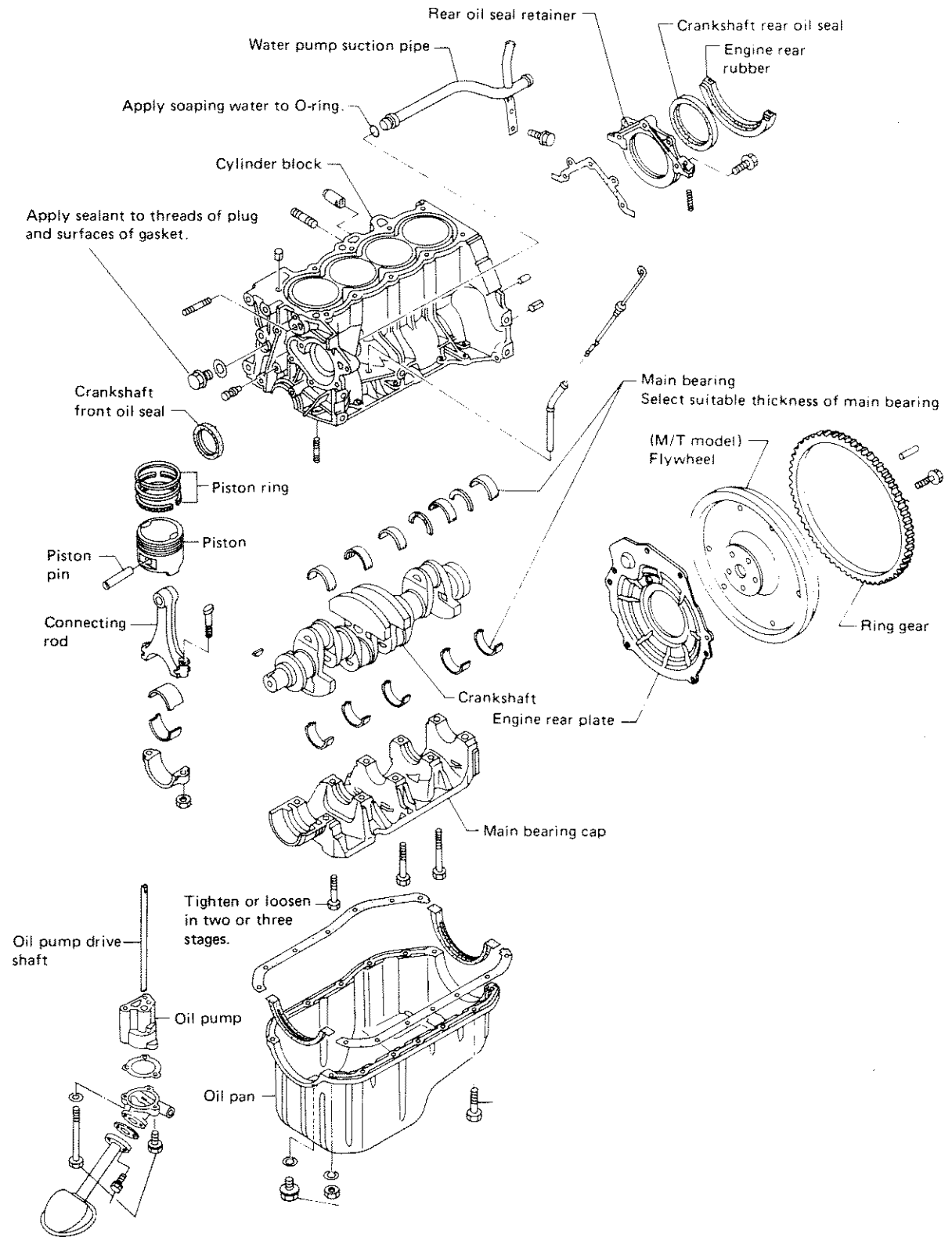

E Check piston ring gap as shown.

Top Ring

No. 1 Grade..... 0.0083-0.0118 inch (0.21-0.30mm)
 No. 2 Grade..... 0.0071-0.0118 inch (0.18-0.30mm)
 No. 3 Grade..... 0.0071-0.0118 inch (0.18-0.30mm)

Second Ring ... 0.0059-0.0154 inch (0.15-0.39mm)

Oil Ring 0.0079-0.0311 inch (0.20-0.79mm)

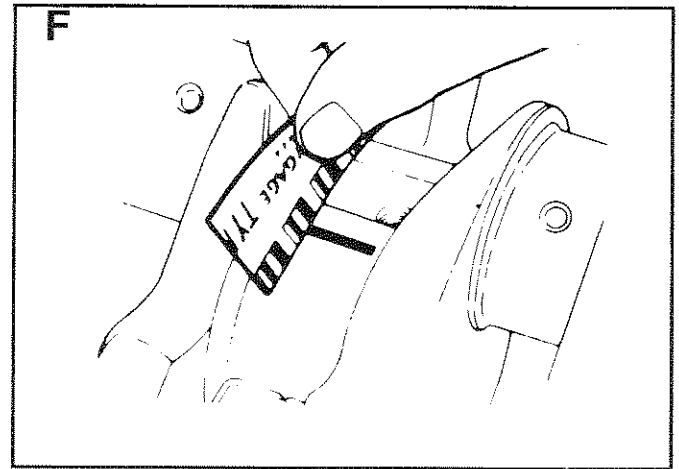
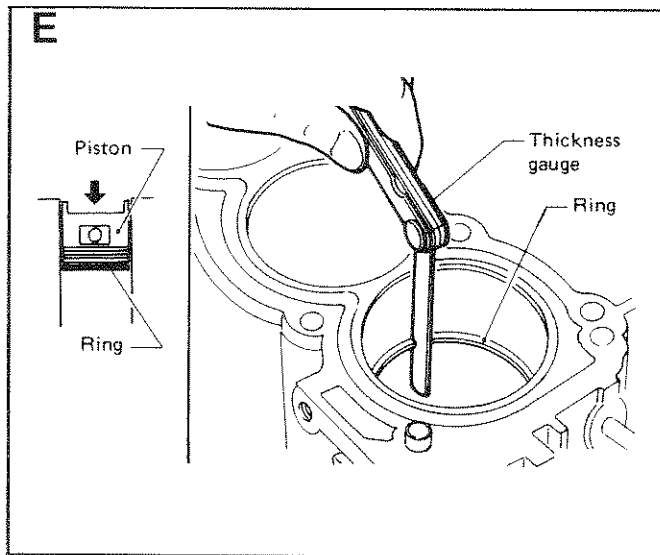

G Inspect crankshaft journals for scoring, bias, wear or cracks. Minor defects may be corrected using fine crocus cloth. Use a micrometer to check journals for taper and out-of-round.

Out-of-Round (X-Y).....0.0004 inch (0.01mm)
Taper (A-B).....Less than 0.0008 inch (0.02mm)

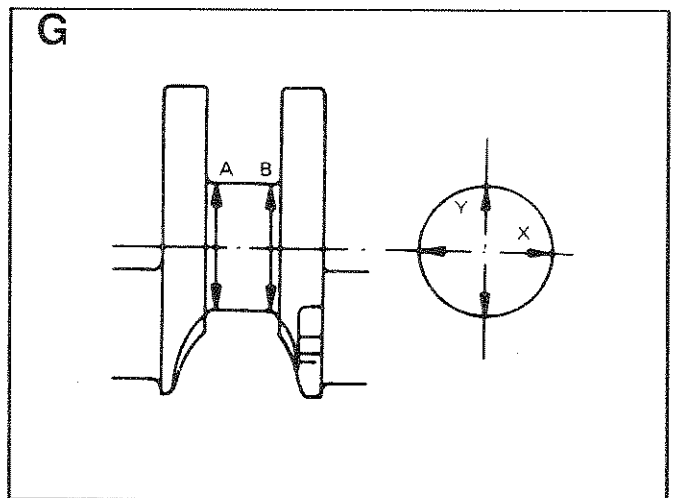

F Use "Plastigage[®]" to check bearing clearance. Comply with the following:

* DO NOT turn crankshaft or connecting rod when plastigage is being inserted.

* When bearing clearance exceeds the specified limit, check that the correct bearing has been installed. If excessive clearance still exists, use thicker main bearing or undersize bearing to obtain specified clearance.

Bearing Clearance

Main Bearing .. 0.0012-0.0020 inch (0.03-0.05mm)
Limit 0.0030 inch (0.075mm)

Connecting

Rod Bearing.... 0.0008-0.0024 inch (0.02-0.06mm)
Limit 0.0047 inch (0.12mm)

H When regrinding crank pin journal, measure the "L" dimension in fillet roll. Measured value must exceed the specified limit. If measurements are within the specified limit, do not regrind.

"L"Greater than 0.0051 inch (0.13mm)

IMPORTANT: DO NOT grind off fillet roll. Refer to applicable **SPECIFICATIONS** chart for regrinding crankshaft and available service parts.

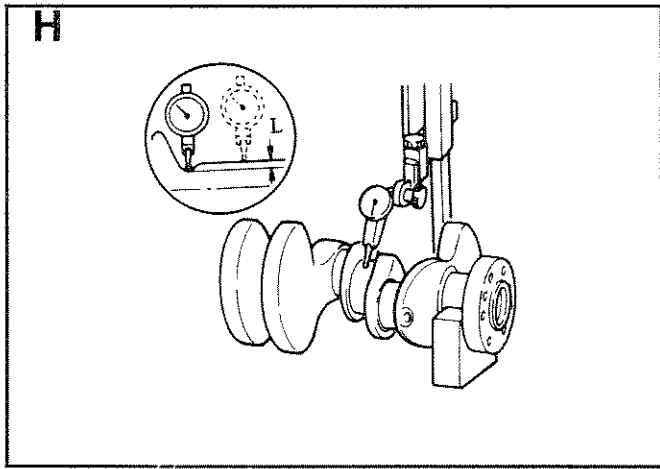

J Check crankshaft runout.

T.I.R Less than 0.0031 inch (0.08mm)

T.I.R. = Total Indicator Reading

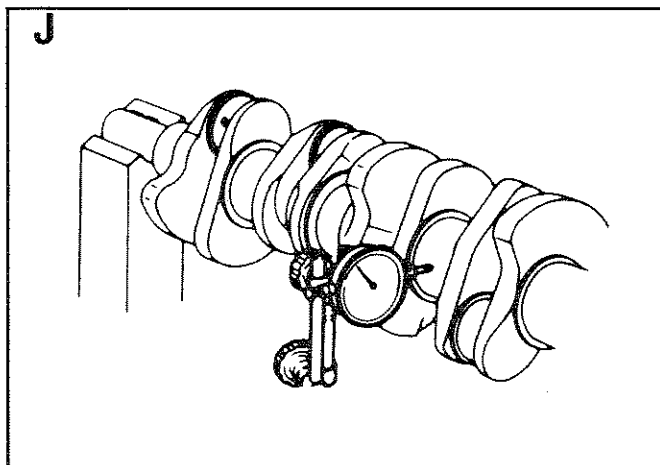

K Surface warpage must be less than 0.004 inch (0.1mm). If beyond the specified limit, resurface cylinder block.

Resurfacing limit of cylinder block is determined by the amount of resurfacing done on cylinder head. If the amount of resurfacing on the cylinder head is "A" and the resurfacing on the cylinder block is "B", the maximum limit is as follows:

$$A + B = 0.008 \text{ inch (0.2mm)}$$

IMPORTANT: When resurfacing, use care not to cut off the punched piston grade number.

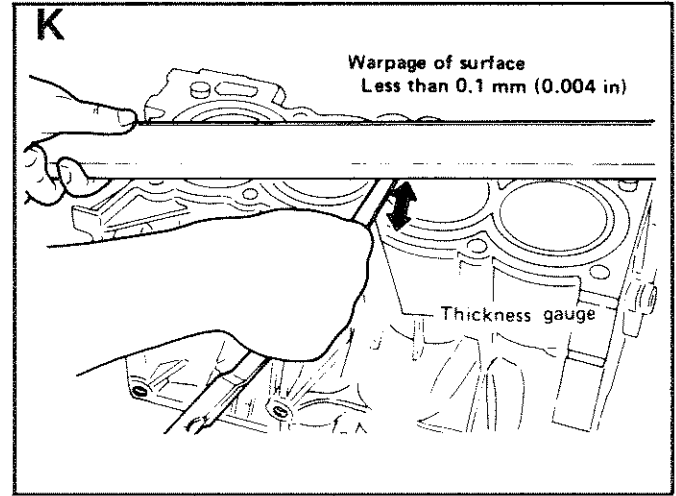

L Use a bore gauge to measure cylinder bore for wear, taper or out-of-round. Inspect for scratches or seizure, hone bore as necessary.

- Standard Inside Diameter 2.7953-2.7965 inch (71.00-71.03mm)
- Out-of-Round (X-Y) Limit 0.0008 inch (0.02mm)
- Taper Limit (A-B) 0.0008 inch (0.02mm)

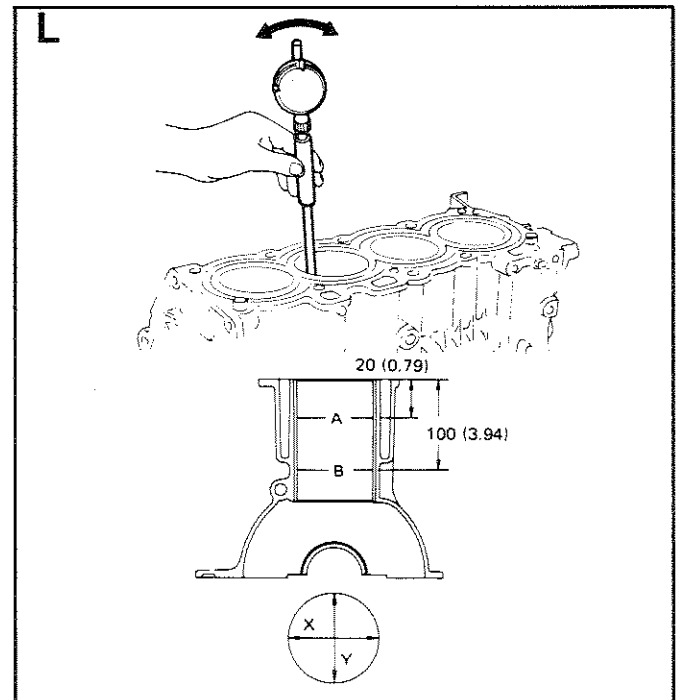

M Use a micrometer to measure piston skirt diameter.

Standard Piston Skirt
Diameter..... 2.6759-2.6770 inch (67.967-67.997mm)

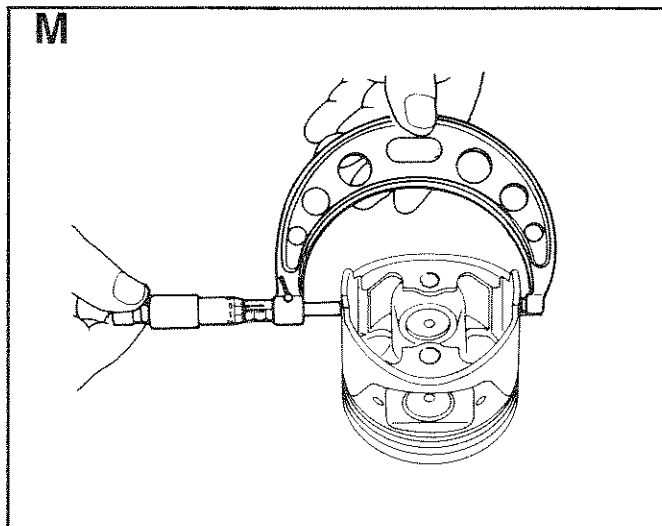

N Measuring point for checking piston skirt diameter should be 0.35 inch (9mm) as shown (Point "L").

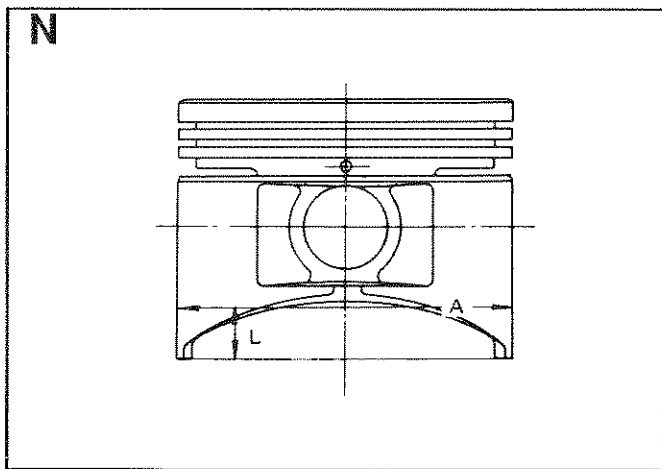

Piston clearance must be within the stated specification.

Piston
Clearance..... 0.0009-0.0017 inch (0.023-0.043mm)

O Measuring Piston Clearance:- Use a 0.0016 inch (0.04mm) thick feeler gauge, inserted between piston and cylinder bore. Force required to remove the feeler gauge should be as specified.

Removal
Force 1.1-3.3 pounds (0.5-1.5kg)

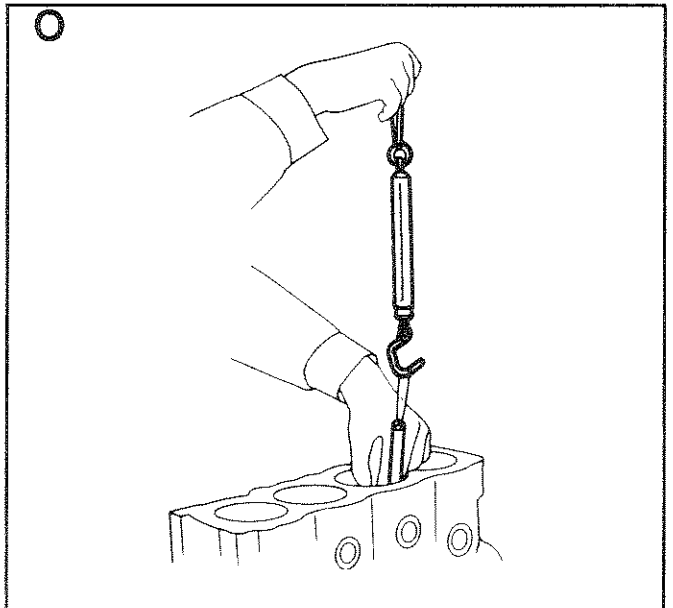

P Check Flywheel Runout:- Total indicator reading (T.I.R.) should be less than specified.

T.I.R.
Runout.....Less than 0.0059 inch (0.15mm)

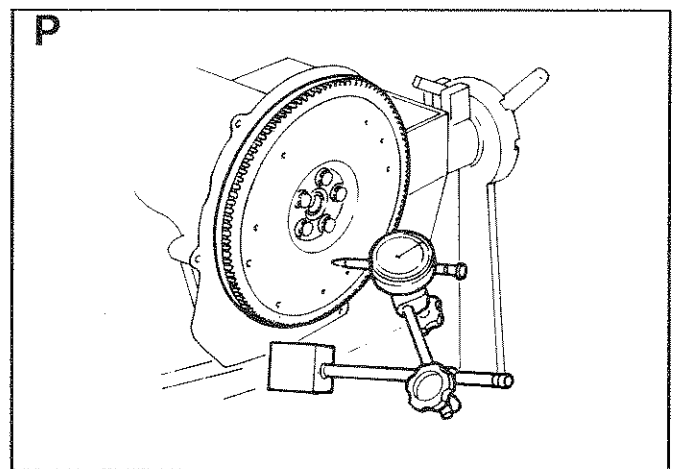

2.6.3- Assembly

Q Piston:- Numbers are stamped on connecting rod and connecting rod caps, which correspond to the cylinder number. Pistons, connecting rods, rod caps and bearings should be installed only in the correct cylinder. **DO NOT COMBINE PARTS FROM DIFFERENT CYLINDERS.** When pressing piston pin into connecting rod, apply engine oil to pin and small end of connecting rod.

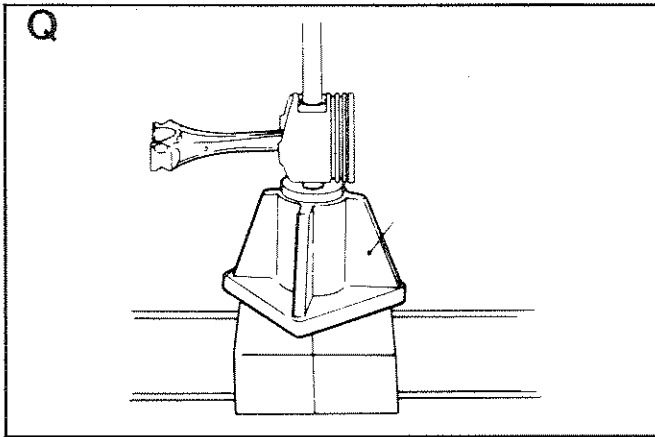

R Crankshaft:- Place main bearings in their proper position on cylinder block.

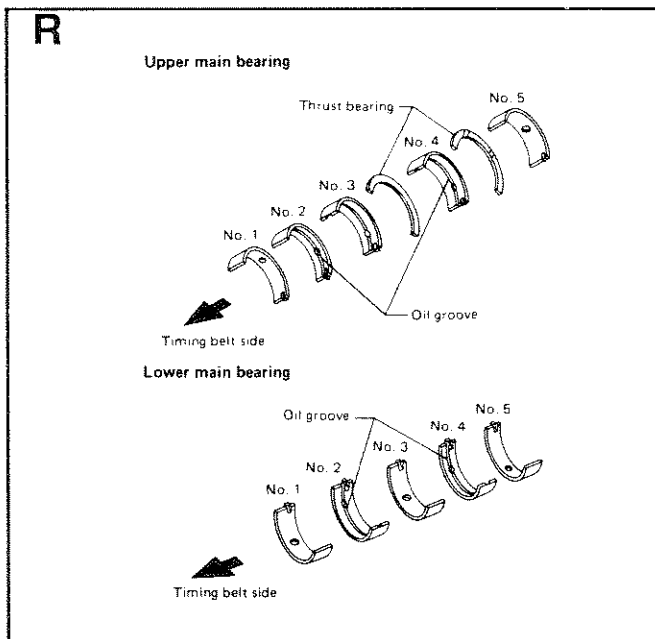

S Main Bearing Selection:- If the crankshaft, cylinder block and main bearings are to be replaced, you must select proper main bearing thickness as follows:

IMPORTANT: When either the crankshaft, cylinder block or main bearings are to be re-used, it will be necessary to measure main bearing thickness with plastigage.

Numbers are stamped on the engine which indicate cylinder block main journal. Each bore must be measured separately.

T Each crankshaft has stamped numbers which indicate main journal dimensions. Each journal is measured separately.

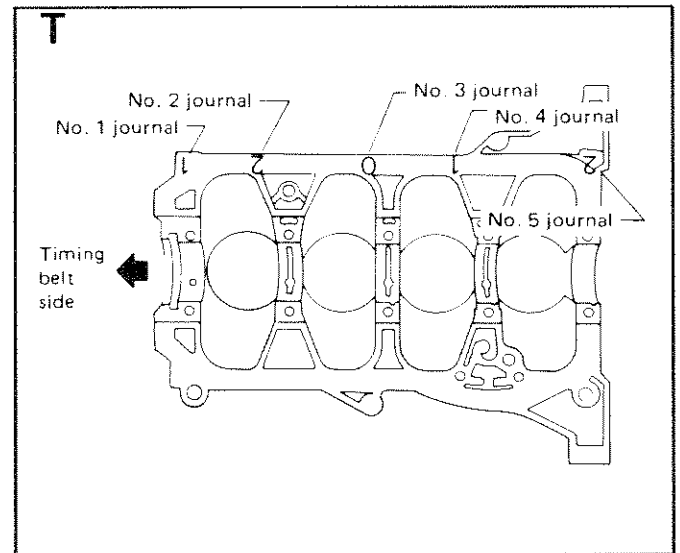

U Select main bearing thickness and order from parts manual.

V Install Piston Assembly:- Install piston rings as shown in illustration.

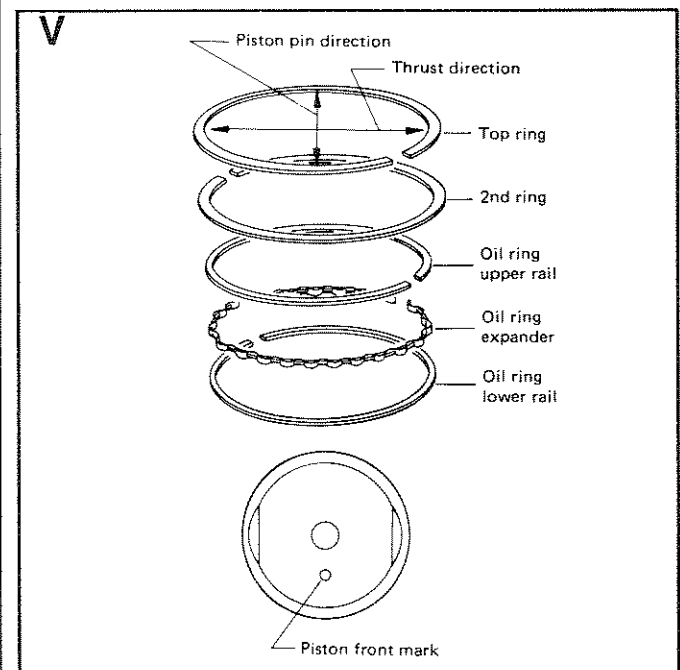

W Install main bearing caps and tighten bolts to 34-38 foot-pounds (46-52 N-m). Always tighten in 2 or 3 stages. Before tightening bearing cap bolts, place cap in proper position by shifting crankshaft axially. After tightening the bearing cap bolts, make sure crankshaft turns smoothly by hand.

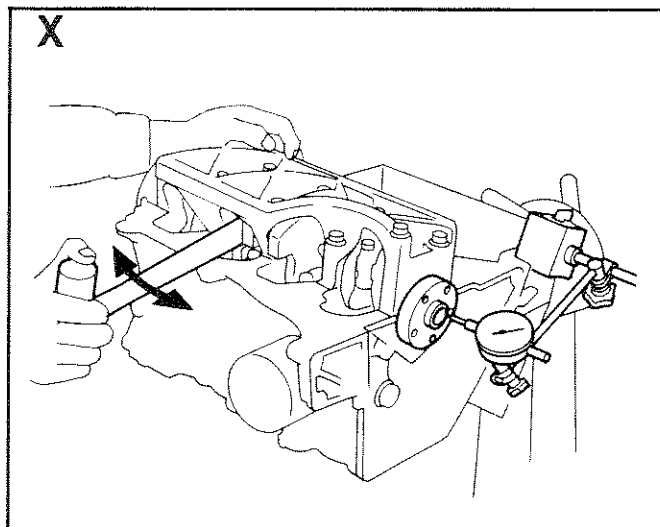
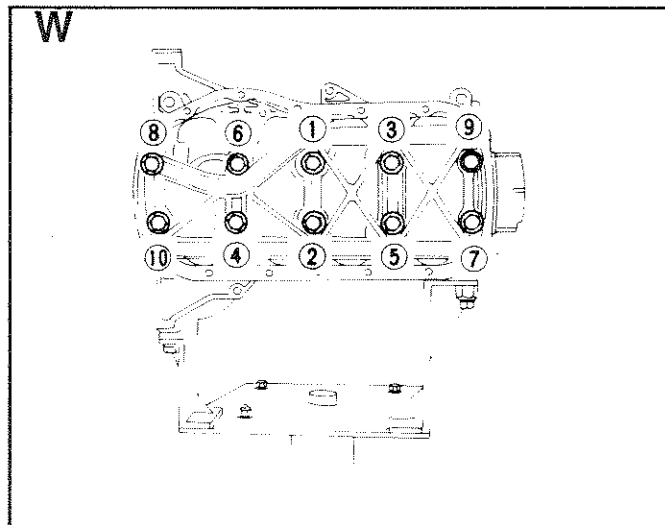

X Measure crankshaft free end play at the center bearing.

End Play 0.0024-0.0087 inch (0.06-0.22mm)
Wear Limit 0.0197 (0.50mm)

Y Measure connecting rod end play.

End Play 0.0039-0.0146 inch (0.10-0.37mm)

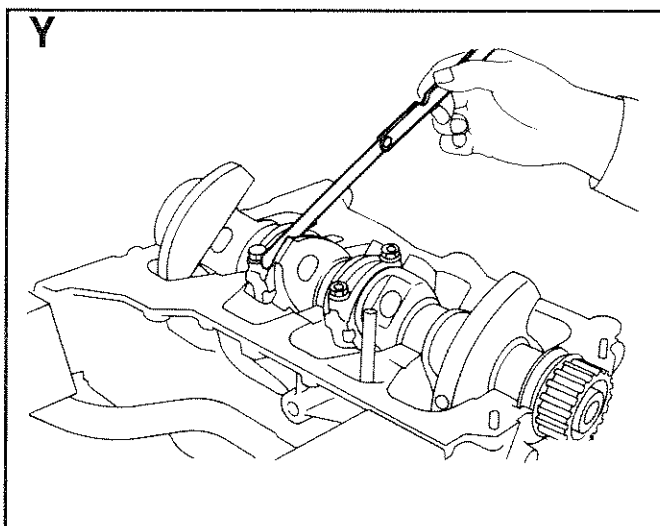

ENGINE LUBRICATION & COOLING SYSTEM

Section 3.1 - Engine Lubrication System

- 3.1.1- Oil Pressure Check
- 3.1.2- Oil Pump Disassembly
- 3.1.3- Oil Pump Inspection
- 3.1.4- Low Oil Pressure Shutdown

Section 3.2 - Cooling System Water Pump and Thermostat

- 3.2.1- Water Pump
- 3.2.2- Thermostat

Section 3.3 - Heat Exchanger and Exhaust Outlet

- 3.3.1- General
- 3.3.2- Radiator Cap
- 3.3.3- Zinc Anode
- 3.3.4- High Exhaust Temperature Switch

Section 3.4 - Automatic Protective Shutdown Switches

- 3.4.1- High Coolant Temperature Switch
- 3.4.2- High Exhaust Temperature Switch
- 3.4.3- Testing the High Coolant Temperature Switch
- 3.4.4- Testing High Exhaust Temperature Switch
- 3.4.5- Operational Tests

Section 3.5 - Sea Water System

- 3.5.1- The Sea Water System

Section 3.6 - Cooling System Periodic Maintenance

- 3.6.1- Sea Water Pump Operation
- 3.6.2- Freezing Temperature Operation
- 3.6.3- Checking Captive Coolant Level

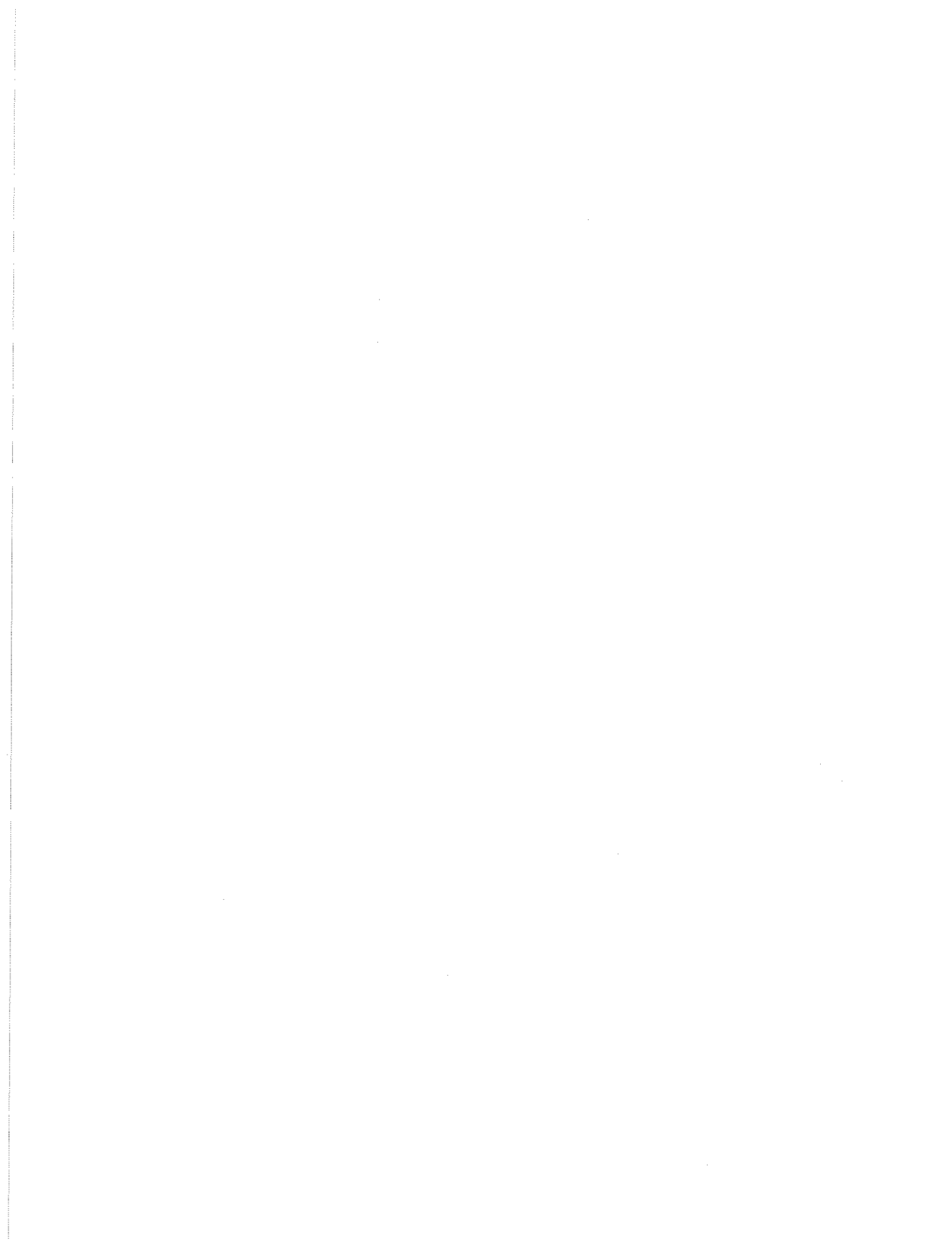

SECTION 3.1 - ENGINE LUBRICATION SYSTEM

3.1.1- Oil Pressure Check

A Warm up engine. Then, shut down and remove oil pressure switch. Install a direct reading pressure gauge. Start engine and check oil pressure with engine running at no-load condition (no electrical loads connected to generator). Oil pressure should be approximately 40-46 psi (2.8-3.2 kg/cm²) at 1860 rpm.

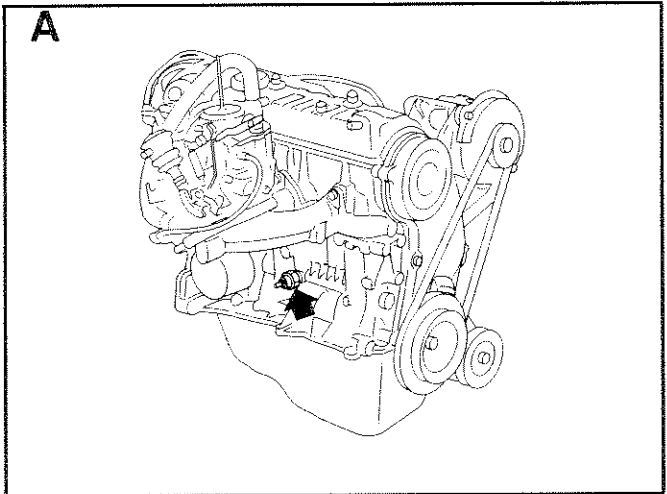

Engine Lubrication Circuit

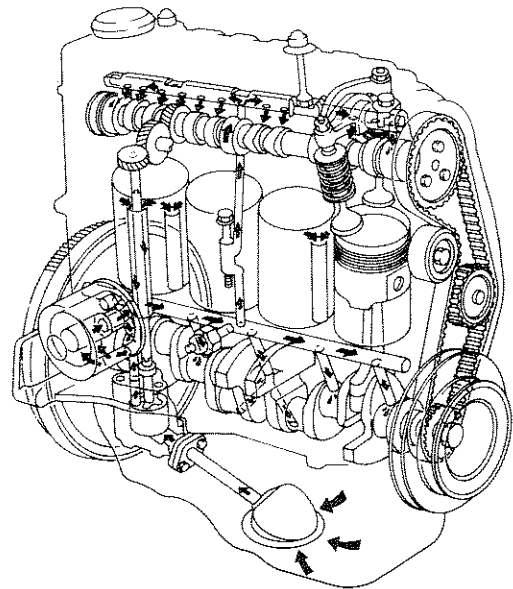
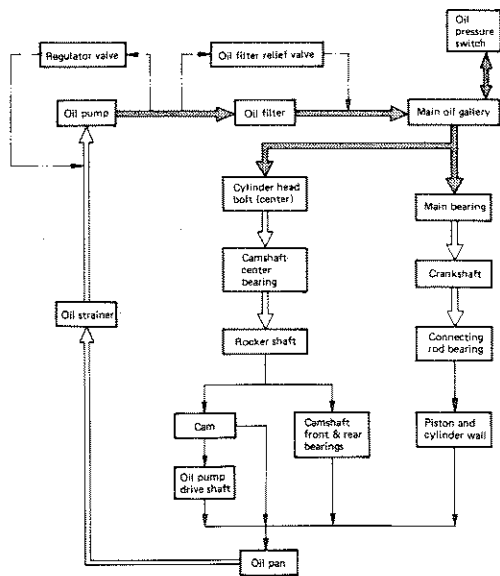

Note:
↔ Oil passage
↔ Oil gallery in cylinder block
- - - Bypass passage

3.1.2- Oil Pump Disassembly

B When removing oil pump assembly, be careful not to drop the oil pump drive shaft. When installing the pump, apply engine oil to drive gear and shaft. The inner rotor and shaft cannot be disassembled.

3.1.3- Oil Pump Inspection

C Visually inspect parts for wear and damage. Check oil pressure regulator valve sliding surfaces and valve spring. Replace valve seat, if damaged. Using a feeler gauge, check the following clearances:

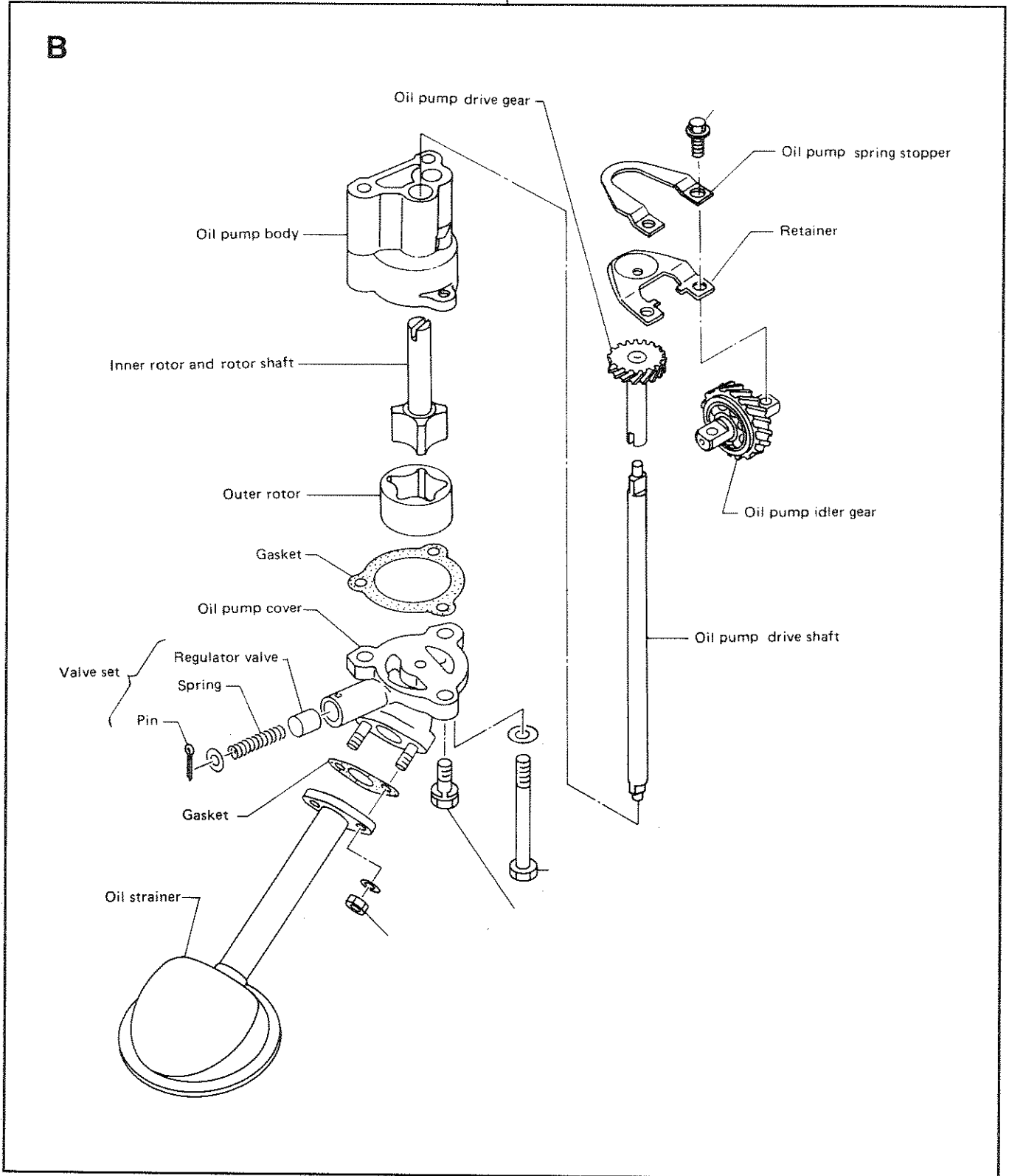

- * (1) Rotor Tip
Clearance..... Less than 0.008 Inch (0.2mm)
- * (2) Outer Rotor to Body
Clearance..... Less than 0.008 Inch (0.2mm)
- * (3) Rotor to Straight
Edge Less than 0.008 Inch (0.2mm)

3.1.4- Low Oil Pressure Shutdown

D Should engine oil pressure during operation drop below approximately 15 psi, an automatic engine shutdown will occur. The low oil pressure sensing port senses oil pressure in the engine main oil gallery. The switch is normally-closed (N.C.), is held open by oil pressure during startup and operation.

To test the low oil pressure shutdown feature, start engine and run at no-load (all electrical loads disconnected from generator). Remove wire from oil pressure switch and hold its terminal end against a clean frame ground. After a short delay, engine should shut down.

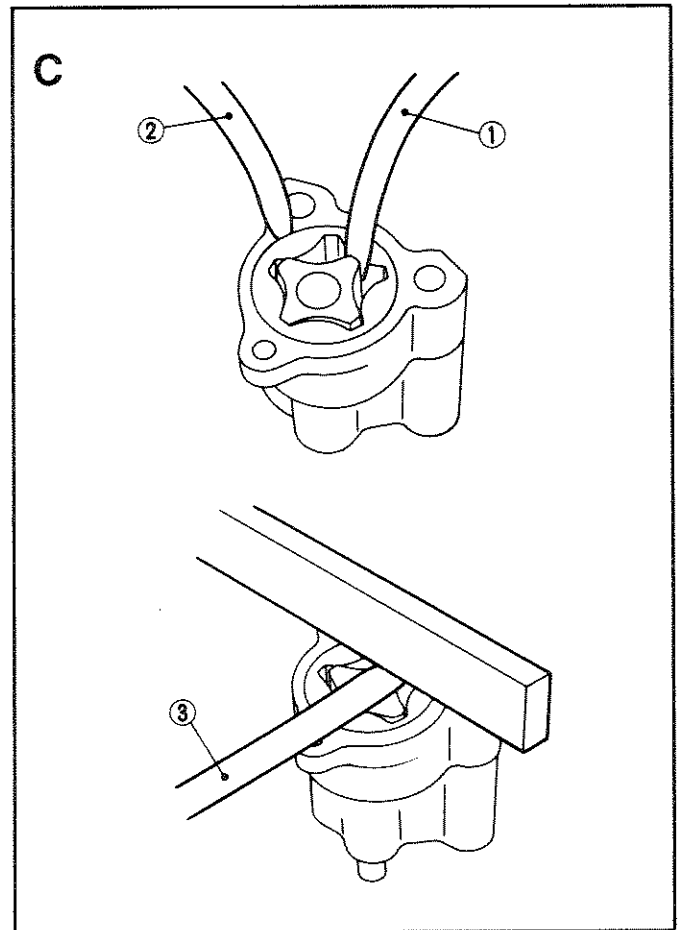
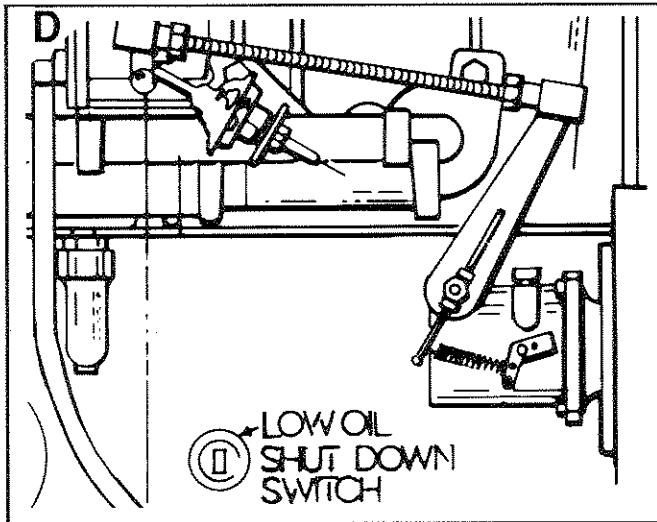

COOLING CIRCUIT

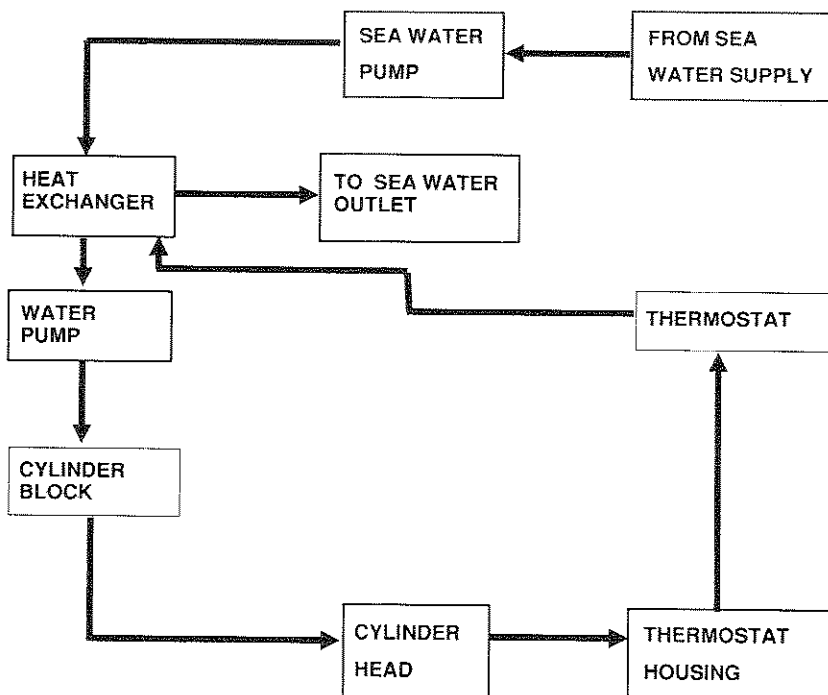
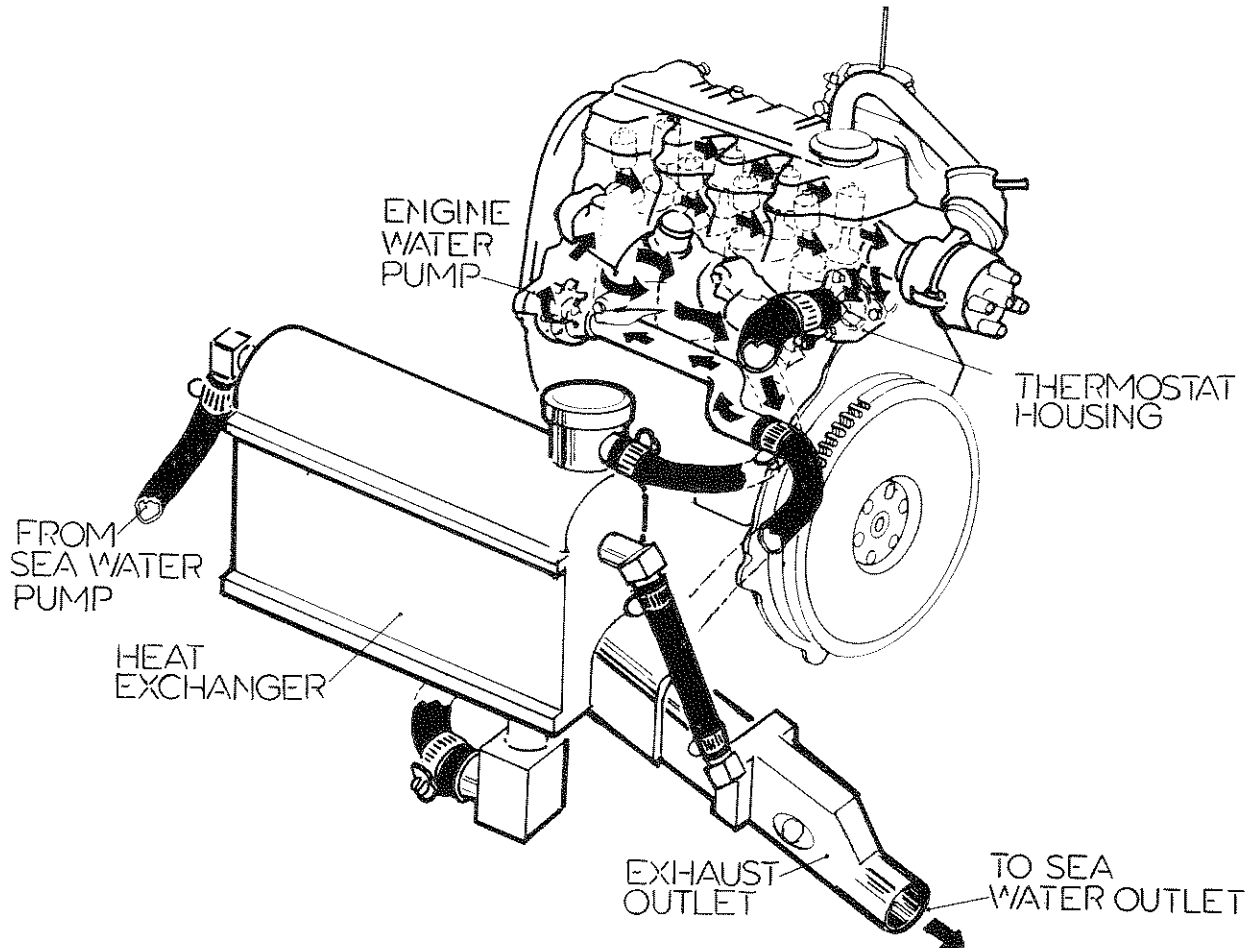

SECTION 3.2 - COOLING SYSTEM WATER PUMP AND THERMOSTAT

3.2.1- Water Pump

A The engine water pump cannot be disassembled and must be replaced as a unit. Check pump for excessive end play and smoothness of rotation. Bolt holes are drilled through water jacket in the cylinder block. Use a sealant and tighten the bolts to their recommended torque. After installation, operate engine and check for leaks.

3.2.2- Thermostat

B & C Check thermostat for proper seating at ambient temperature. It should seat tightly. Check opening temperature and valve lift.

Valve Opening

Temperature ... 190° F. (88° C.)

Maximum Valve

Lift 0.31 inch at 212° F. (8mm at 100° C.)

Also check that valve closes at 9° F. (5° C.) below valve opening temperature.

Following installation, run engine and check for leaks.

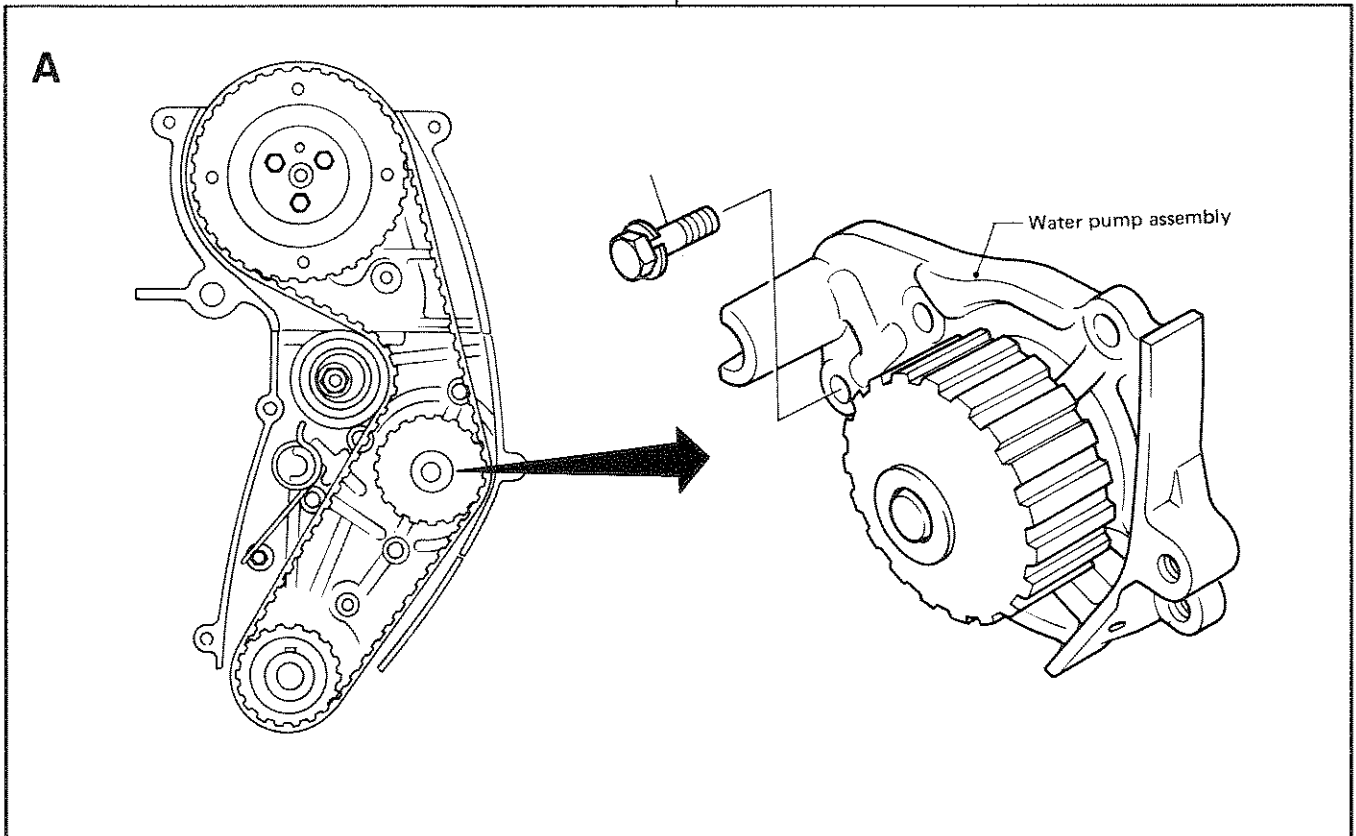
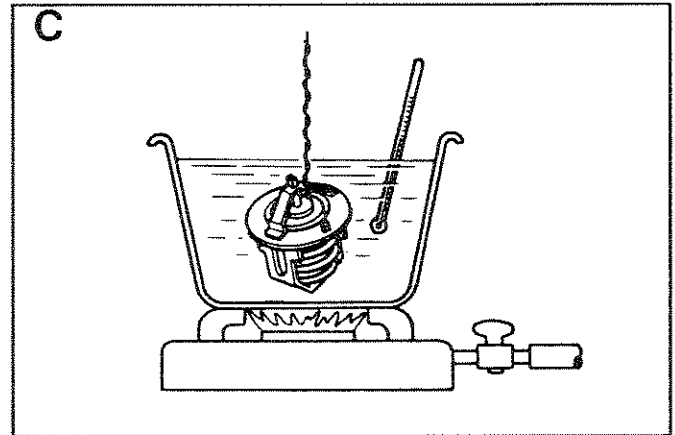
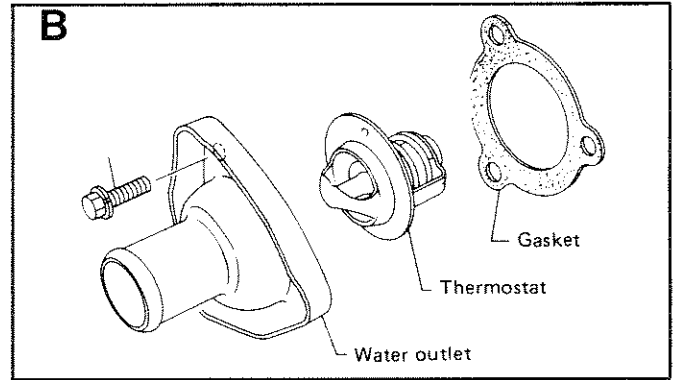

SECTION 3.3 - HEAT EXCHANGER AND EXHAUST OUTLET

3.3.1- General

When working on the heat exchanger assembly, comply with the following:

- * Tighten all M6 fasteners on Heat Exchanger to 7 foot-pounds
- * Apply LOCTITE[®] 242 to all studs before installing them into Heat Exchanger exhaust manifold.
- * Apply LOCTITE[®] pipe sealant to all 1/2 and 5/8 inch pipe fittings on Heat Exchanger.
- * Apply ANTI-SEIZE COMPOUND to EXHAUST OUTLET PIPE NIPPLE before installing it.
- * Apply PLIOBOND[®] gasket sealant to all gasket surfaces before installation.
- * Apply PETROLEUM JELLY to exhaust manifold o-ring before the tube bundle is installed.
- * Pressure test captive water coolant chamber in Heat Exchanger at 30 psi (engine coolant chamber).
- * Pressure test sea water and exhaust outlet chamber at 30 psi.

3.3.2- Radiator Cap

A Use an automotive type cooling system pressure tester to test radiator cap opening pressure. Opening pressure should be approximately 12.5-13.5 psi. The cap is also equipped with a vacuum relief valve. Proper operation of both pressure and vacuum relief valves is necessary for operation of the coolant recovery system.

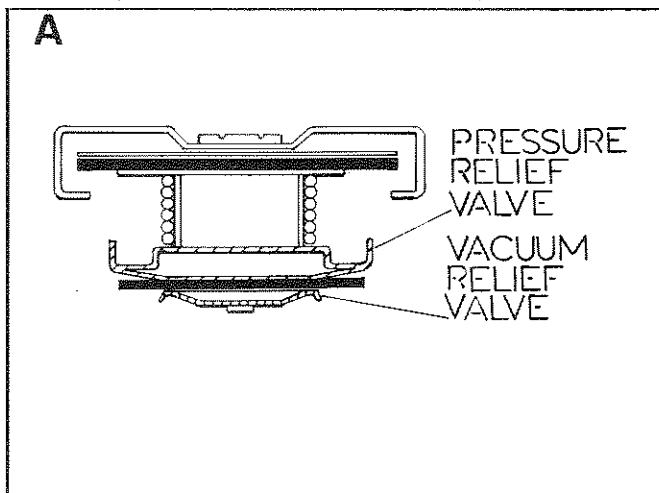

3.3.3- Zinc Anode

B This sacrificial anode will erode to protect other cooling system parts against corrosion. Replace the anode if eroded 50% or greater.

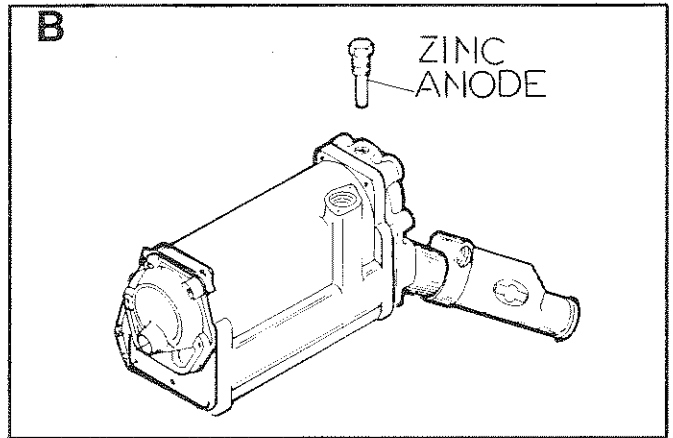

3.3.4- High Exhaust Temperature Switch

C If water temperature in exhaust outlet fitting exceeds approximately 246°-266° F. (119°-130° C.), engine will shut down automatically. The switch protects the exhaust system hoses against heat damage that might result in leakage of exhaust fumes into areas inhabited by people. See Section 3.4.

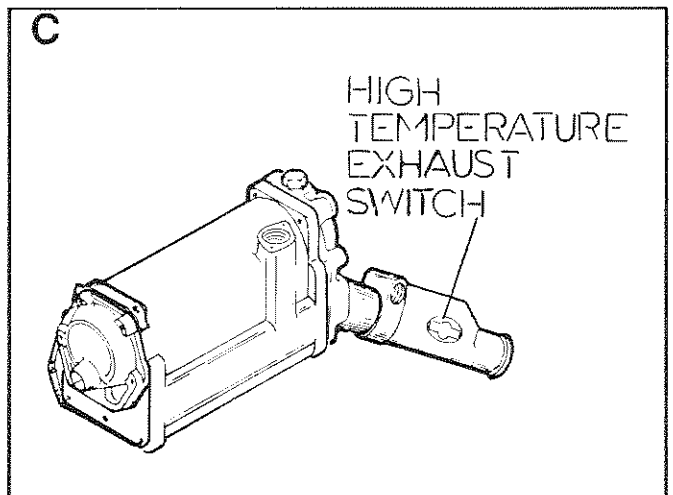

HEAT EXCHANGER & EXHAUST OUTLET

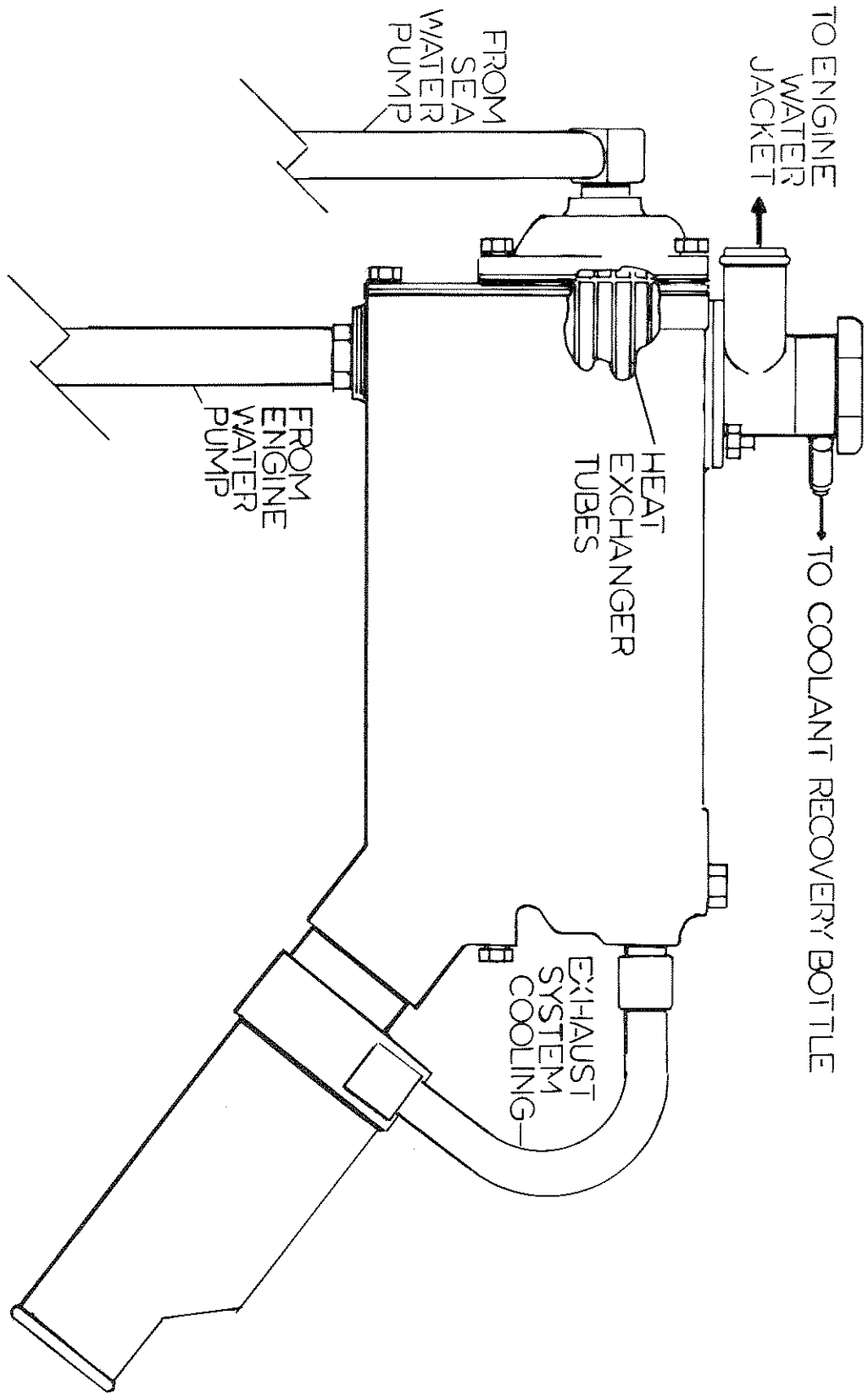

SECTION 3.4 - AUTOMATIC PROTECTIVE SHUTDOWN SWITCHES

3.4.1- High Coolant Temperature Switch

A A normally-open (N.O.) thermostatic switch has a sensing tip, which is immersed in captive (engine water jacket) coolant. Should captive coolant exceed approximately 230° F. (110° C.), the switch contacts will close and (after a short delay) the engine will shut down.

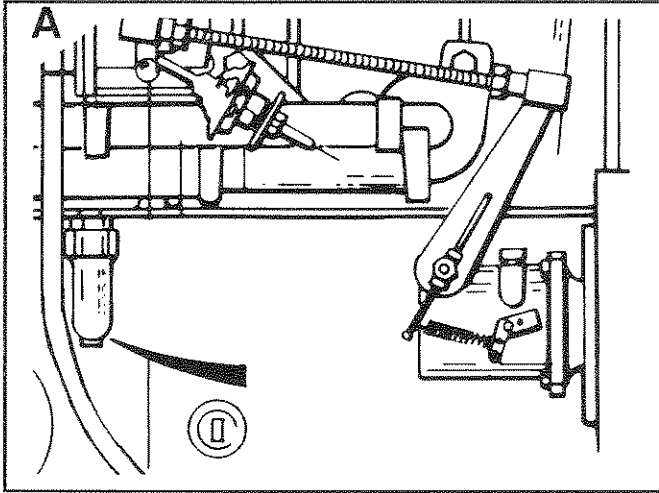

3.4.2- High Exhaust Temperature Switch

See Paragraph 3.3.4 on Page 6.

3.4.3- Testing the High Coolant Temperature Switch

B Remove switch and check switch contacts closing temperature with an ohmmeter. Contacts should close at about 225°-235° F. (107°-113° C.).

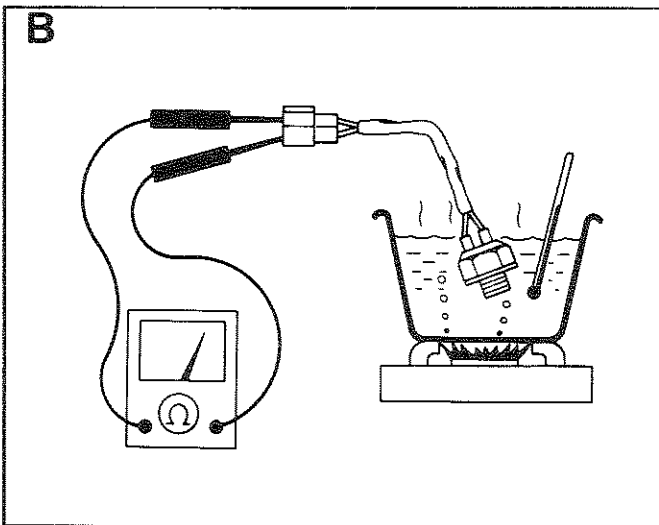

3.4.4- Testing High Exhaust Temperature Switch

C Use an ohmmeter to check closing temperature of switch contacts. Contacts should close at 246°-266° F. (119°-130° C.).

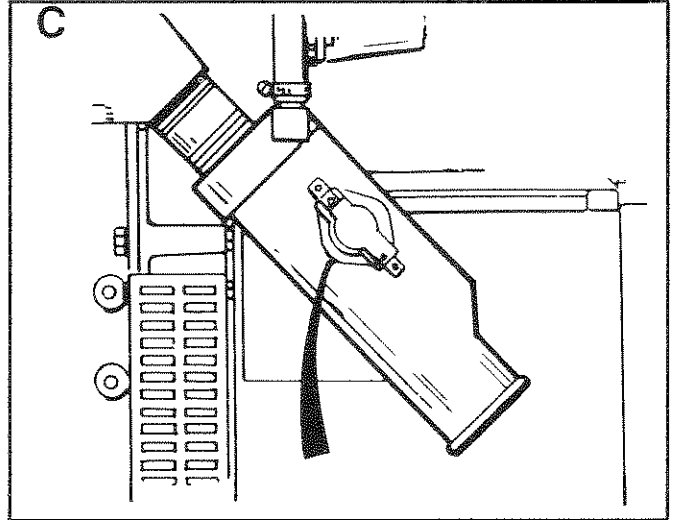

3.4.5- Operational Tests

IMPORTANT: Operational tests of automatic shutdown systems must be done with the engine at no-load (no electrical loads connected to generator).

D Remove Wire #85 from switch terminal. Start engine, let it stabilize and warm up at no-load. Hold terminal end of Wire #85 into firm contact with a clean frame ground. After a short delay, engine should shut down.

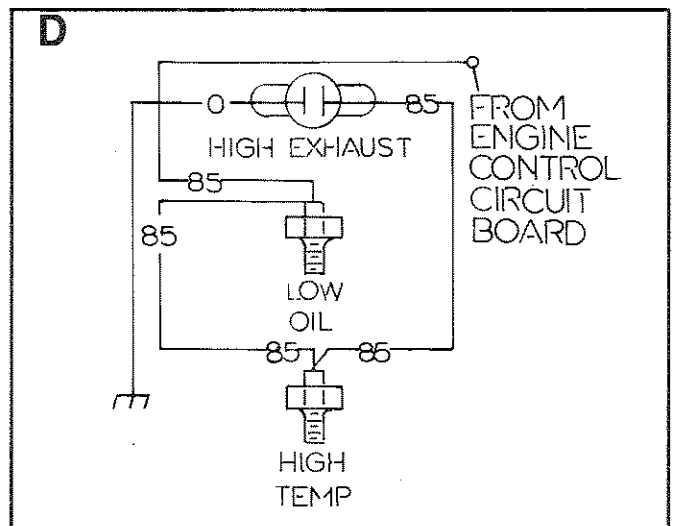

SECTION 3.5 - SEA WATER SYSTEM

3.5.1- The Sea Water System

A Sea water (raw water), rather than air, is used to extract heat from the captive coolant during operation. This sea water is pumped into the heat exchanger and exhaust outlet by a sea water pump. The following rules apply to this system:

IMPORTANT: Only a flush type (through the hull) raw water inlet fitting should be used on a vessel. **DO NOT USE "SCOOP TYPE" FITTING.** A forward facing scoop can force seawater past the seawater pump and into the engine.

* Sea water system suction lines **MUST** be AIR TIGHT or the pump will not self prime. The pump depends on sea water for its lubrication. **NEVER RUN THE PUMP DRY FOR LONGER THAN 30 SECONDS.** Lack of water will result in damage to the pump impeller.

* Sea water pump maximum lift (when dry) is approximately 10 feet (3.0m). When wet, the pump will produce a suction lift of about 22 feet (6.7m).

* Water **MUST** be available to the sea water pump before the engine is started. Without an adequate flow of water through the sea water system, pump damage and engine/exhaust system overheating will occur.

* Sea water pump flow rate is approximately 6 U.S. gallons per minute.

An engine water pump (Section 3.2) forces captive water through the engine cylinder block, cylinder head and heat exchanger. Sea (raw) water is pumped through the heat exchanger, to cool the captive water. After being cooled, the captive water is returned to the engine water pump and recirculated through the system. The sea water is pumped into the exhaust outlet fitting and overboard through the exhaust system.

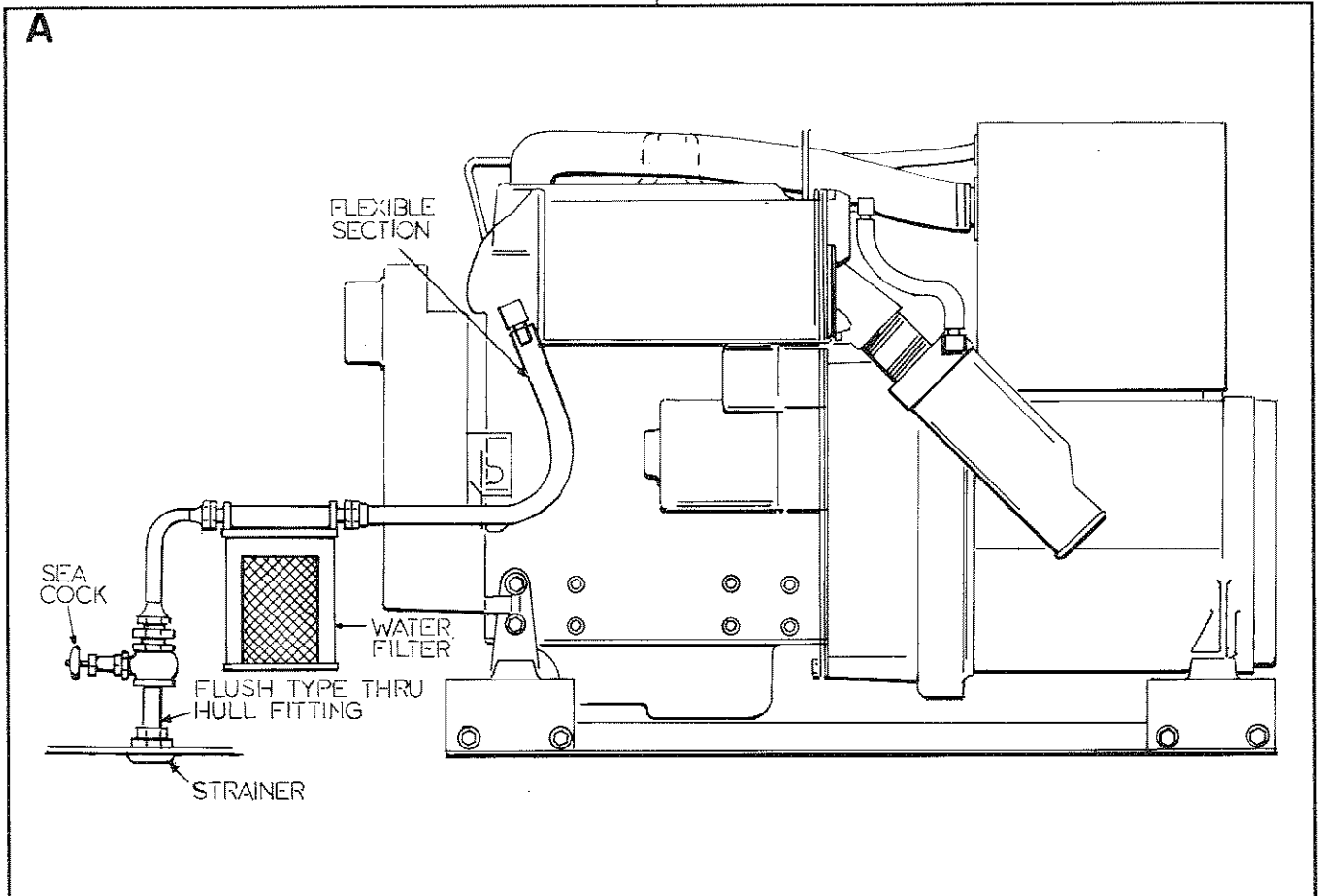

EXPLODED VIEW OF SEA WATER PUMP

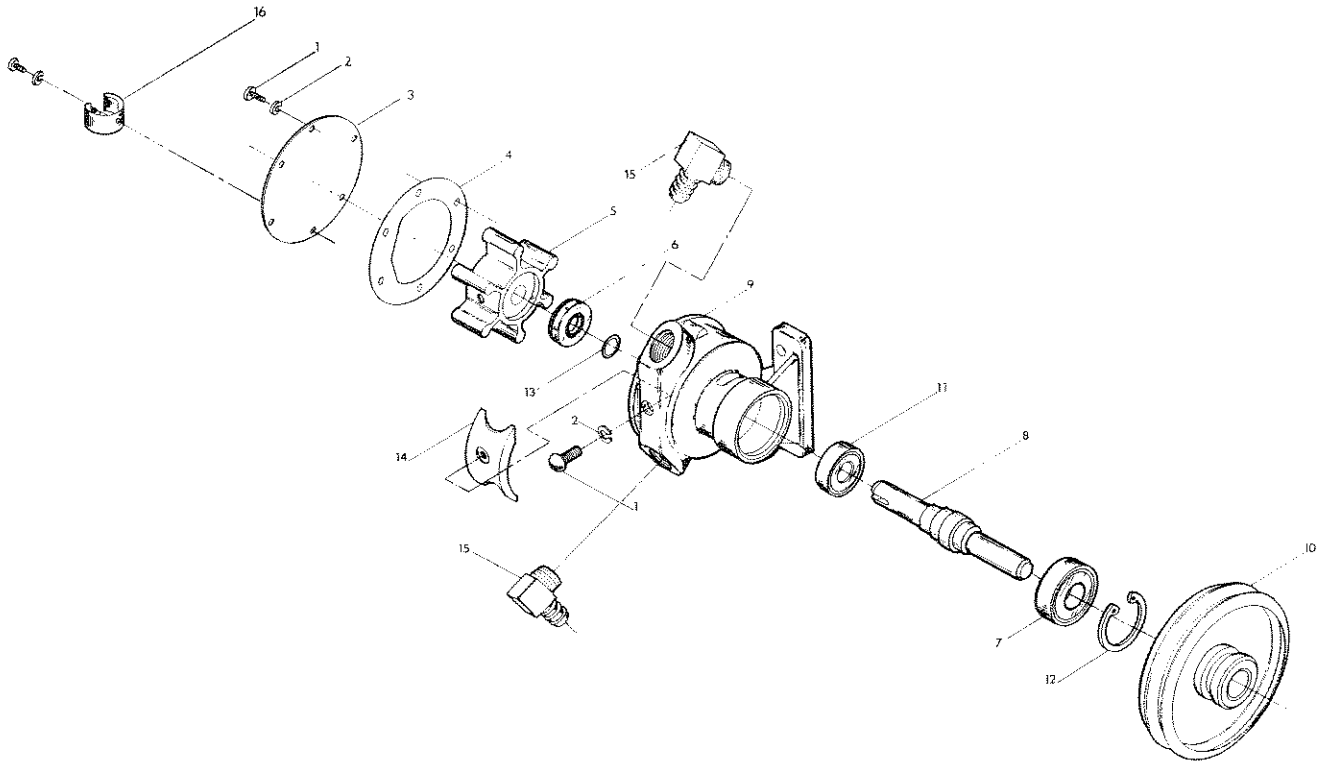

REF NO.	DESCRIPTION
1	SCREW- M5-0.80 x 8mm
2	LOCKWASHER- M5
3	BACK PLATE
4	GASKET
5	IMPELLER
6	WATER SEAL
7	BALL BEARING
8	SHAFT
9	PUMP HOUSING
10	PUMP PULLEY
11	PUMP BEARING
12	INTERNAL SNAP RING
13	O-RING
14	PUMP CAM
15	ELBOW- 3/8" NPT x 5/8" ID
16	SPRING CLIP

SECTIONAL VIEW OF SEA WATER PUMP

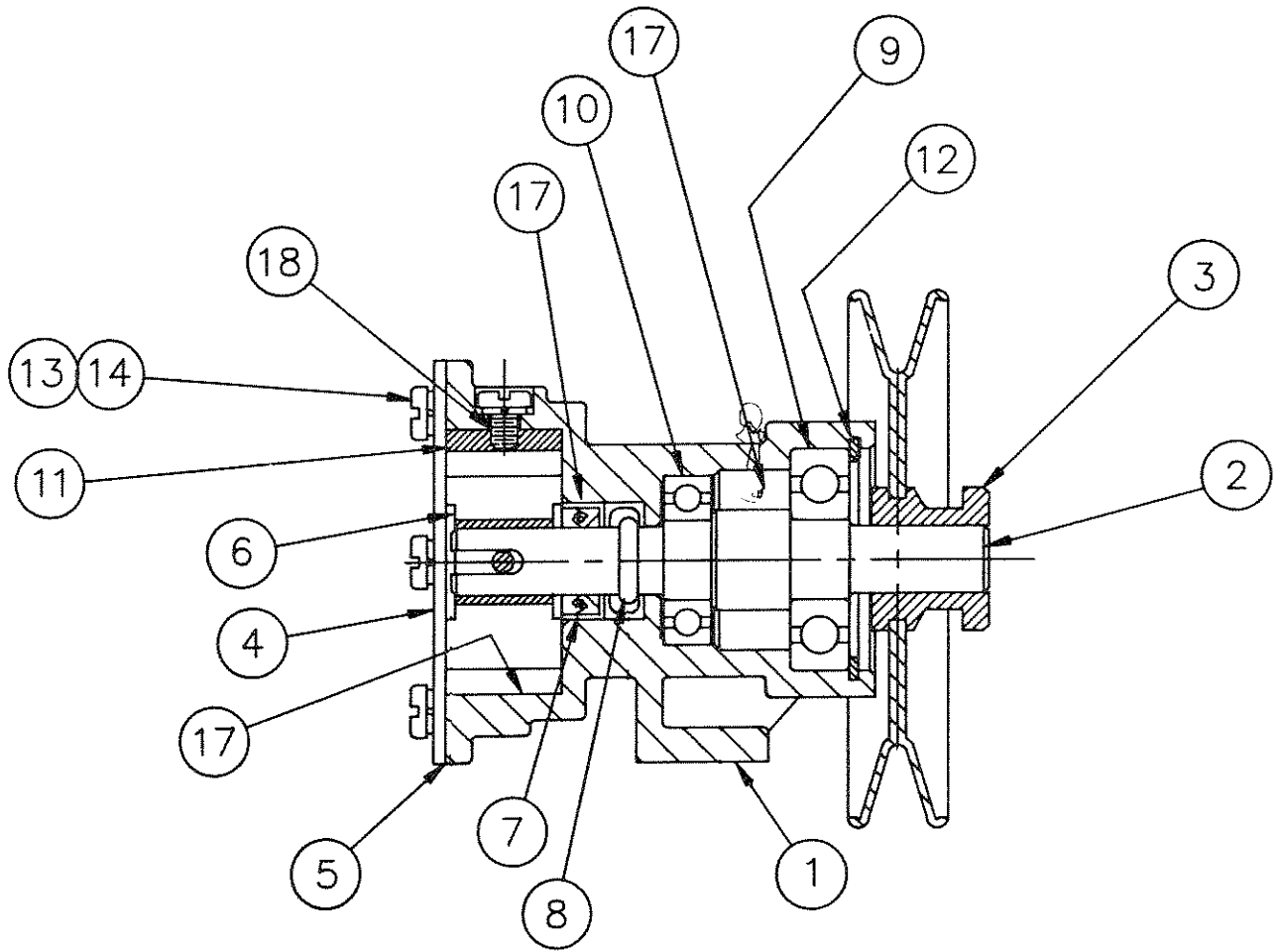

REF NO.	DESCRIPTION
1	PUMP HOUSING
2	SHAFT
3	PUMP PULLEY
4	BACK PLATE
5	GASKET
6	IMPELLER
7	WATER SEAL
8	O-RING
9	BEARING
10	BEARING
11	PUMP CAM
12	INTERNAL SNAP RING
13	SCREW- M5-0.80 x 8mm
14	LOCKWASHER- M5
17	PACK AREA WITH GREASE
18	SCREW- M5-0.80 x 8mm

SECTION 3.6 - COOLING SYSTEM PERIODIC MAINTENANCE

3.6.1- Sea Water Pump Operation

The owner/operator of the vessel in which the marine generator is installed is responsible for the following operational and maintenance requirements:

- * Sea water pump operation must be checked daily. This can be done by observing the sea water flow from the vessel's exhaust outlet.
- * The vessel's sea water cock must be opened before operating the marine generator.
- * If the sea water system includes a sea water filter, that filter **MUST** be checked periodically. Even a partially clogged filter may result in engine and exhaust system overheating.
- * Clamps and fittings on sea water suction hoses must be tight and the system must be free of leaks. Any leakage in the suction side of the system can result in loss of the pump's self priming capability, loss of sea water flow, and engine/exhaust system overheating.

▲WARNING

Without adequate sea water, engine and/or exhaust system damage may result. Damage to the exhaust system can result in serious injury or death to occupants of the vessel caused by carbon monoxide poisoning.

3.6.2- Freezing Temperature Operation

The engine captive water system was factory serviced with a 50-50 mixture of ethylene glycol base anti-freeze and soft water. When adding coolant, only the recommended 50-50 mixture should be used. If the recommended 50-50 mixture is added consistently, the marine generator will be adequately protected against freezing temperatures.

▲CAUTION

When adding coolant or when refilling the cooling system after flushing, use only a **LOW SILICATE**, ethylene glycol base anti-freeze formula and use **SOFT WATER** only. If a rust inhibitor is used, do not use any chromate base inhibitor with ethylene glycol base anti-freeze or the formation of "green slime" (chromium hydroxide) will result. In addition, the formation of "green slime" may be caused by (a) use of high silicate anti-freeze boosters or additives, (b) use of hard water, or (c) use of a high ratio of anti-freeze to water. Do not exceed 60% anti-freeze in the coolant mixture. Formation of "green slime" will lower the heat transfer rate and cause overheating.

3.6.3- Checking Captive Coolant Level

Daily checks of captive coolant level may be accomplished by checking the coolant recovery bottle. Add the recommended 50-50 mixture to the recovery bottle as required.

Periodically, remove the pressure cap from the heat exchanger to ensure the coolant recovery system is functioning properly. Coolant level must be at top of heat exchanger filler neck. If coolant level is low, inspect gasket in pressure cap for damage or wear. Replace cap, if necessary. Cap may be tested as outlined in Paragraph 3.3.2. Also inspect cooling system and coolant recovery system for leaks.

Section 4.1- Fuel System

- 4.1.1- Fuel Recommendations
- 4.1.2- Fuel System Components

Section 4.2 - Fuel Pump

- 4.2.1- General
- 4.2.2- Testing and Maintenance

Section 4.3 - Carburetor

- 4.3.1- Disassembly
- 4.3.2- Reassembly
- 4.3.3- Installation
- 4.3.4-

Section 4.4 - Engine Governor Assembly

- 4.4.1- General Description
- 4.4.2- Governor Maintenance
- 4.4.3- Removal of d-c Alternator Assembly
- 4.4.4- Oil Servicing
- 4.4.5- Governor Lever, Links and Spring

PART 4

ENGINE FUEL AND SPEED CONTROL SYSTEM



SECTION 4.1 - FUEL SYSTEM

4.1.1- Fuel Recommendations

Any high quality LEADED or UNLEADED regular grade gasoline having a minimum posted octane rating of 86 (research octane number 90) is satisfactory for use with the marine generator.

The use of any gasoline containing alcohol (either methanol or ethanol) is NOT RECOMMENDED. Gasolines containing alcohol tend to absorb moisture from the air. Such absorption causes the water and alcohol to separate from the gasoline in the fuel tank. Adverse affects of alcohol increase in severity with methyl alcohol (methanol). In addition, the effects worsen with increasing alcohol content. Use of gasoline containing alcohol may cause one or more of the following:

- * Corrosion of metal parts
- * Deterioration of elastomer and plastic parts
- * Fuel permeation through flexible fuel lines
- * Wear and damage of internal engine parts
- * Starting and operating difficulties

If the use of gasoline containing alcohol cannot be avoided, avoid storage of gasoline in the fuel tank(s) for long periods of time. Long periods of fuel storage (common to boats) create unique problems. When used in cars, alcohol blend fuels are consumed before they can absorb enough moisture to cause problems.

IMPORTANT! Use of improper gasoline can damage the engine seriously. Engine damage resulting from the use of improper gasoline is considered misuse of engine and resulting damages will not be covered by warranty. Where possible, only gasolines that are free of alcohol should be used. Where only fuel containing alcohol is available or if the presence of alcohol is unknown, increased inspection frequency for leaks and abnormalities is required.

4.1.2- Fuel System Components

A During engine operation, fuel is pumped from the FUEL TANK by the 12 volts d-c electric FUEL PUMP. Pumped fuel is delivered through a FILTER and into the CARBURETOR. The CARBURETOR mounts an automatic, electric CHOKE. CARBURETOR throttle valve setting is established by the action of a constant speed GOVERNOR. The CARBURETOR atomizes the fuel and delivers it to the engine cylinders, via the INTAKE MANIFOLD.

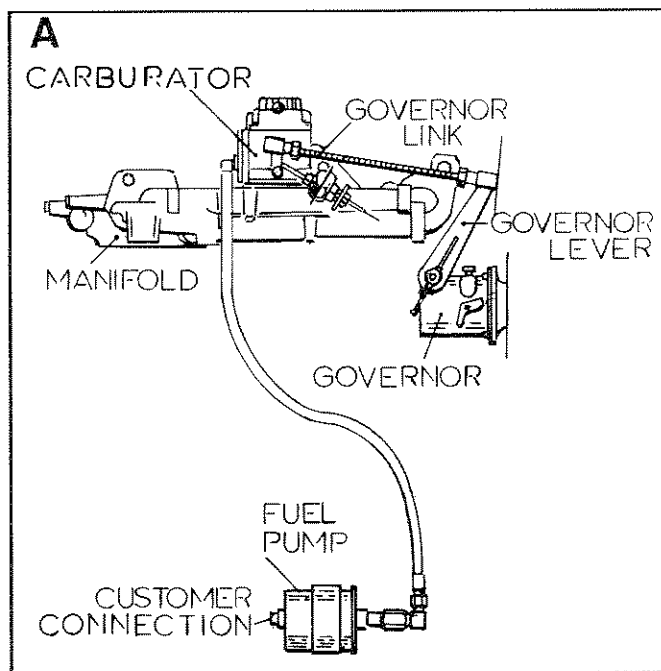

SECTION 4.2 - FUEL PUMP

4.2.1- General

A The fuel pump is energized on by ENGINE CONTROL circuit board action during cranking, startup and operation, via Wire #14. Wire #14 is electrically hot only during cranking and operation. Circuit board and Wire #14 action also energizes (a) a fuel lockoff solenoid, (b) a choke heater, (c) an optional hourmeter, (d) ignition coil, and (e) an optional remote panel generator run lamp (if so equipped).

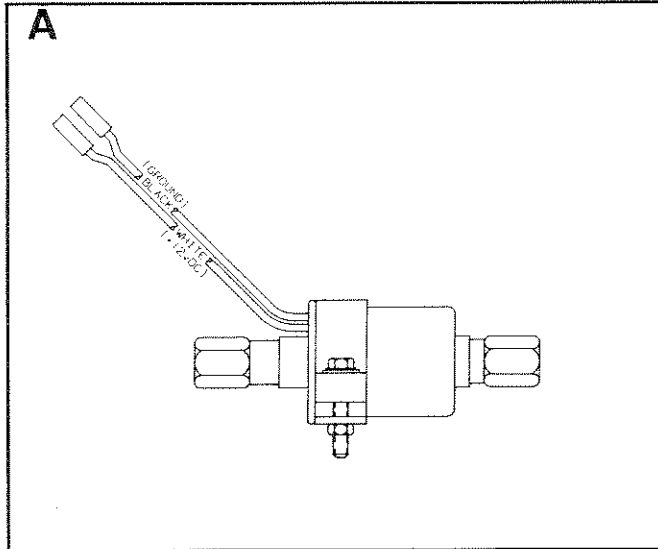

4.2.2- Testing and Maintenance

B An ohmmeter may be used to test continuity of pump windings. To perform operational test, disconnect outlet side line from pump and connect inlet side to a fuel supply. Separate pump lugs and connect a +12 volts d-c power source (such as a battery) to the pump WHITE wire, a negative (-) d-c POWER source to the BLACK (ground) wire. Pump should operate and pump fuel. If defective, replace pump.

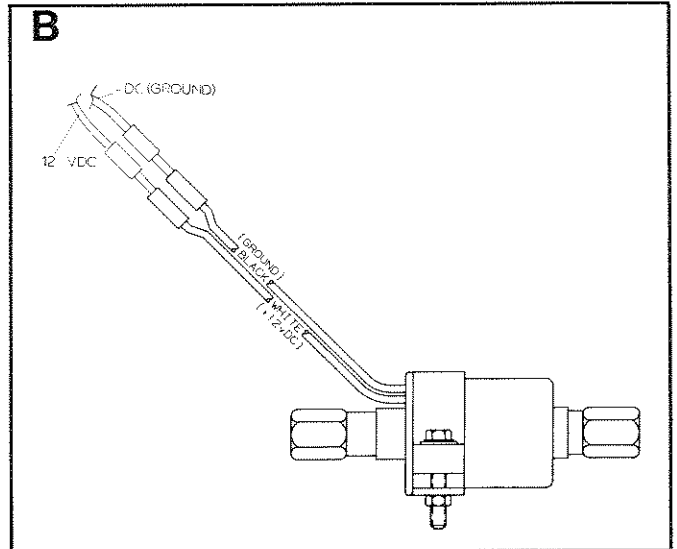

CARBURETOR ASSEMBLY

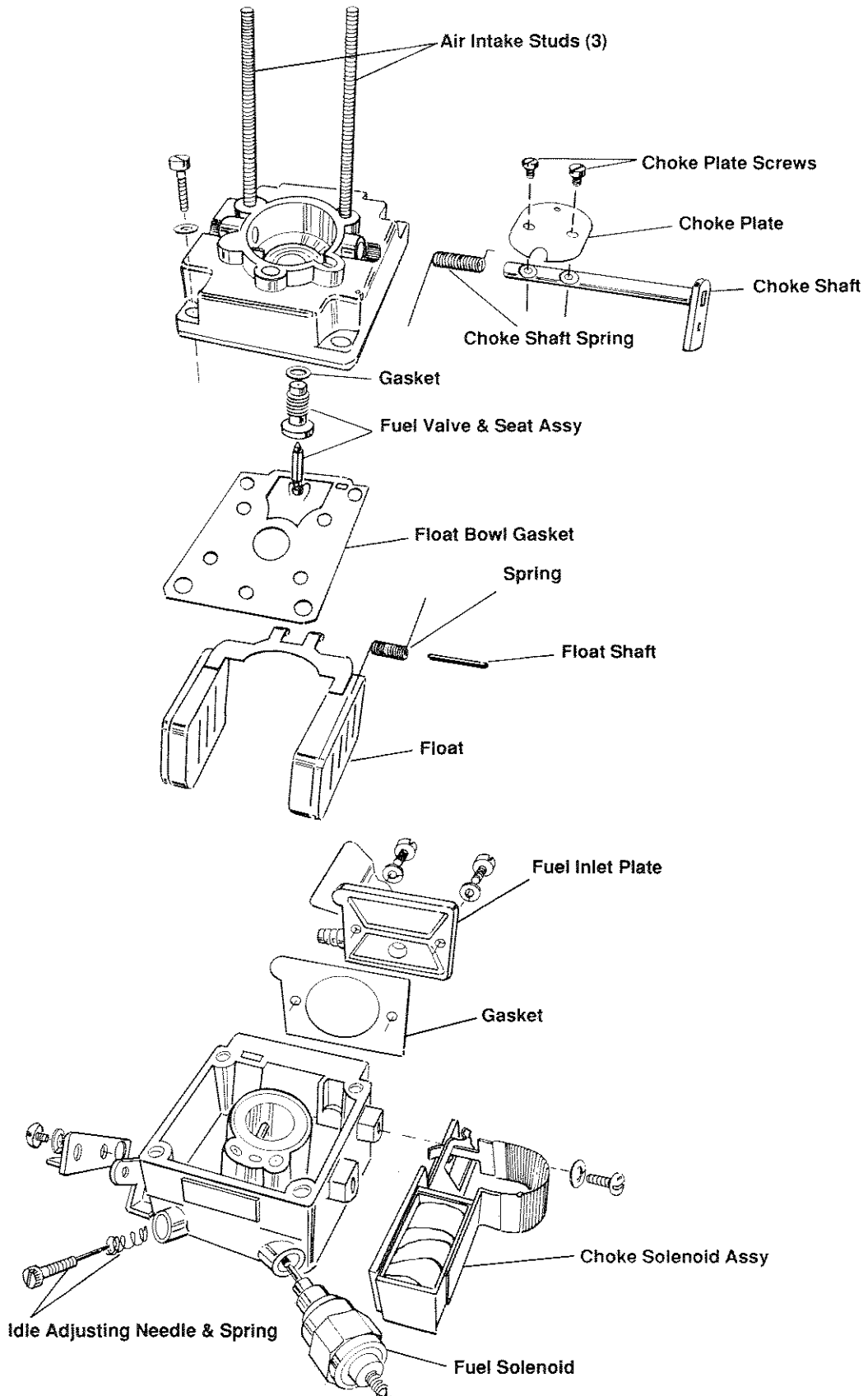

SECTION 4.3 - CARBURETOR

4.3.1- Disassembly

Remove carburetor air intake components (Page 2) as necessary, to gain access to carburetor. Disconnect carburetor/governor link. Disconnect fuel line. Remove carburetor, carburetor adapter and gaskets. Then, disassemble carburetor as follows:-

- a. Remove two SCREWS and LOCKWASHERS, then remove INLET PLATE and GASKET.
- b. Remove two SCREWS and WASHERS and remove automatic CHOKE.
- c. Remove four SCREWS and WASHERS, then remove FLOAT BOWL COVER along with GASKET, FLOAT, FLOAT SHAFT, FLOAT SPRING, FUEL VALVE and SEAT.
- d. Remove FLOAT SHAFT, SPRING, FUEL VALVE and FLOAT.
- e. Remove GASKET.
- f. Remove SEAT ASSEMBLY.
- g. Remove two SCREWS, then remove CHOKE PLATE.
- h. Remove two SCREWS, then remove THROTTLE PLATE.
- i. If necessary for replacement, remove SOLENOID VALVE and SEAL.
- j. Remove IDLE ADJUSTING NEEDLE and SPRING.
- k. Clean all parts in clean gasoline.

4.3.2- Reassembly

Reassemble all parts in the reverse order of disassembly. During the reassembly process install new parts from KIT and pay close attention to the following:

- * Open throttle plate slightly for idle speed.
- * Set idle adjust screw 3/4 turn open.

A With Float Bowl Cover inverted and body gasket installed, set float level 0.125 inch (3.175mm) from body gasket.

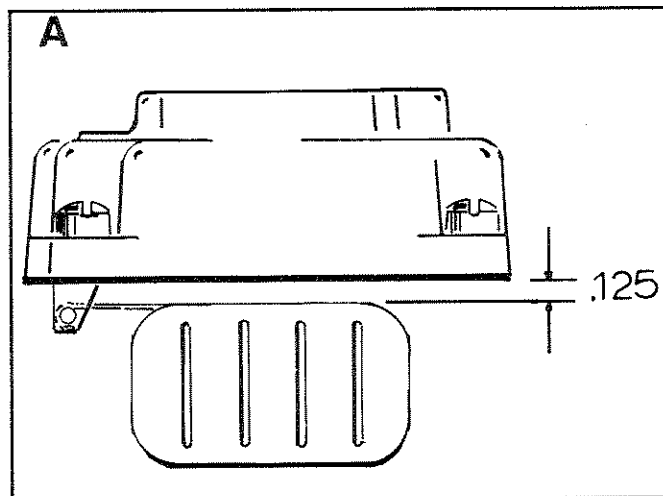

B Tighten air intake mounting screws in the correct sequence, as shown.

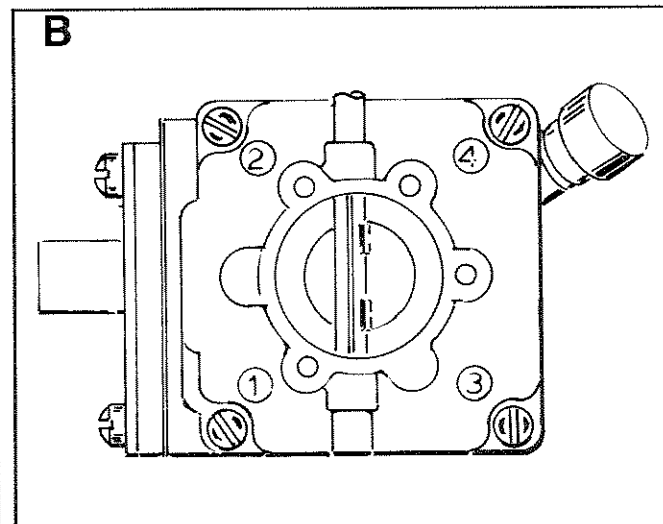

* Check that throttle shaft rotates freely.

* Tighten solenoid valve to 70 inch-pounds.

C Insert short leg of choke spring in small hole in lever, as shown.

D Wind choke spring 1-1/2 turns counterclockwise (CCW) and anchor on retaining screw boss.

4.3.3- Installation

Install GASKET, ADAPTER, GASKET and CARBURETOR. Retain with flat socket head machine screws (1/4"-20).

4.3.4- Adjustment

Refer to Section 1.5 (ADJUSTMENTS). To adjust automatic choke, proceed as follows:

E Loosen choke bracket adjusting screws and adjust choke position so that, with solenoid pulled in, choke plate is closed. Tighten choke bracket adjusting screws. Then, with solenoid extended, bend tip of bi-metal until choke plate is about 1/8 inch from vertical and towards the closed position.

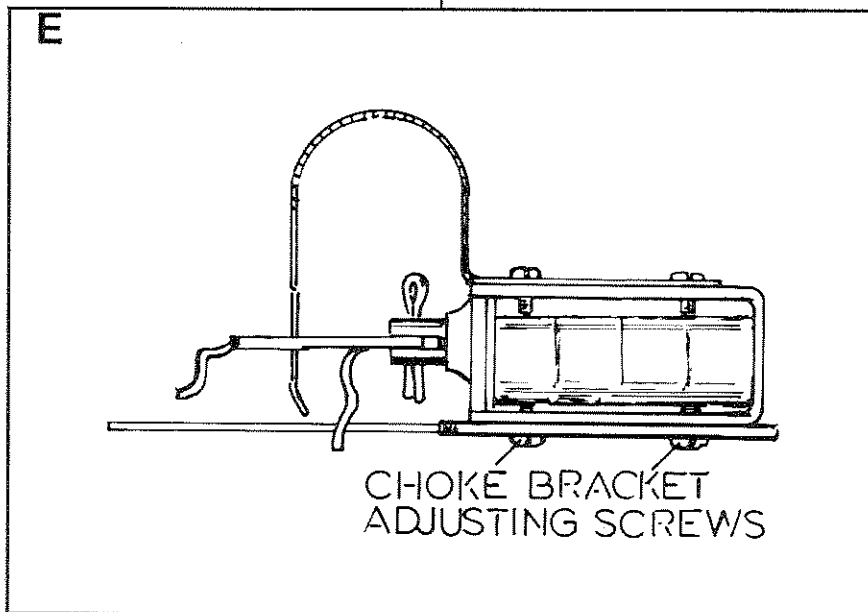
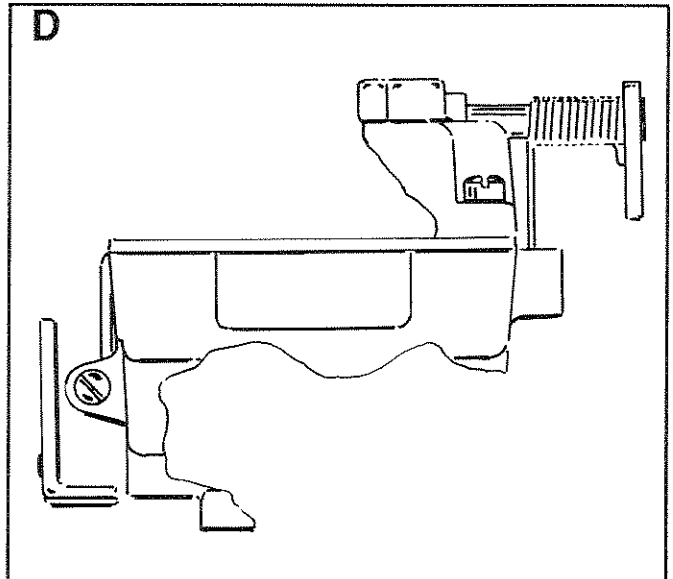
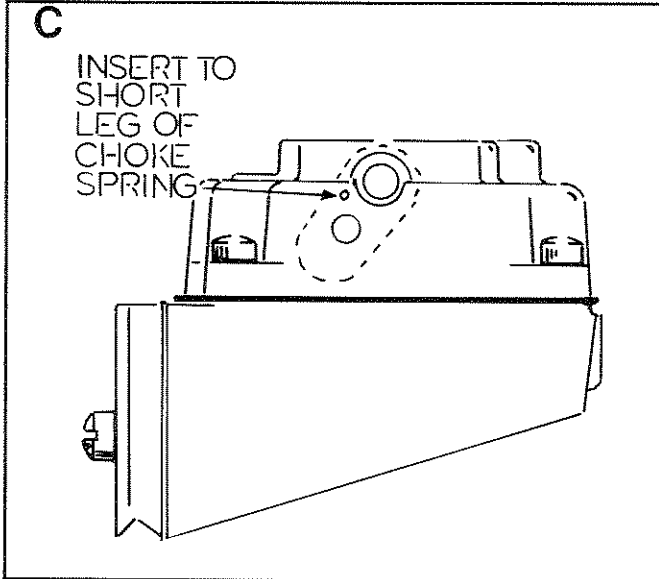

SECTION 4.4 - ENGINE GOVERNOR ASSEMBLY

4.4.1- General Description

A The mechanical, centrifugal type engine governor utilizes spring tension versus centrifugal force to maintain a steady state engine speed regardless of load. When centrifugal flyweight force exceeds governor spring tension, flyweight action against a yoke rotates a rocker shaft to decrease carburetor throttle setting and reduce engine speed. Should engine speed decrease below a specific setting, governor spring tension will become the stronger force. Carburetor throttle setting will then be increased to increase engine speed. Governor action will cease when flyweight force and spring tension are equal and cancel each other.

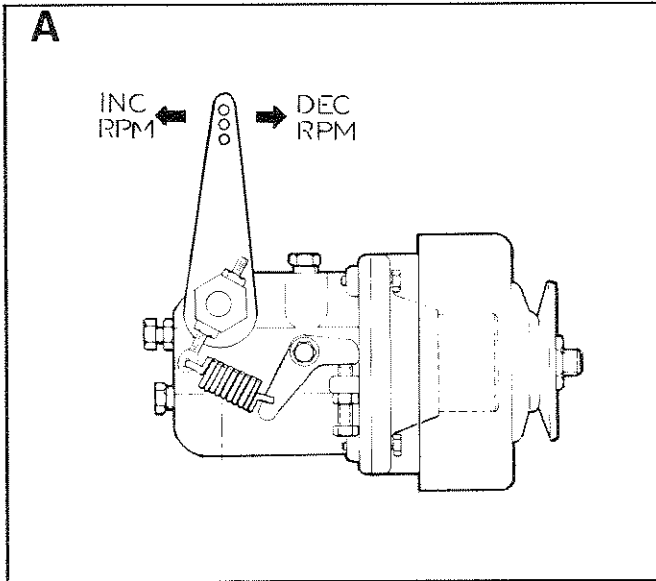

The governor flyweights are driven by an engine drive belt. The governor also supports and drives a d-c alternator assembly, which delivers a charging current to the generator battery during engine operation. See Part 7, ENGINE ELECTRICAL SYSTEM.

4.4.2- Governor Maintenance

Maintenance and repair of the engine governor is limited to (a) removal and replacement of the d-c alternator assembly, (b) removal and replacement of governor lever, spring and links, (c) removal and replacement of governor to carburetor linkage, and (d) adjustment of governed speed.

4.4.3- Removal of d-c Alternator Assembly

See EXPLODED VIEW OF ENGINE GOVERNOR. Remove HEX JAM NUT (Item 43), WAVE WASHER

(Item 48), and PULLEY HALF (Item 44). Then, remove d-c alternator ROTOR (Item 44). Remove SOCKET HEAD SCREWS (Item 35) and LOCKWASHERS (Item 22), then remove STATOR (Item 47).

Install the d-c alternator assembly in the reverse order of removal. Tighten socket head screws that retain the stator to 5 foot-pounds (7 N-m). Tighten the hex jam nut (Item 43) to 35 foot-pounds (47 N-m).

4.4.4- Oil Servicing

B Remove OIL FILLER PLUG and OIL LEVEL CHECK PLUG. Add engine oil through FILLER PLUG until oil just starts to overflow CHECK PLUG opening. Pour slowly. When oil level is correct, install OIL FILLER and OIL LEVEL CHECK PLUGS.

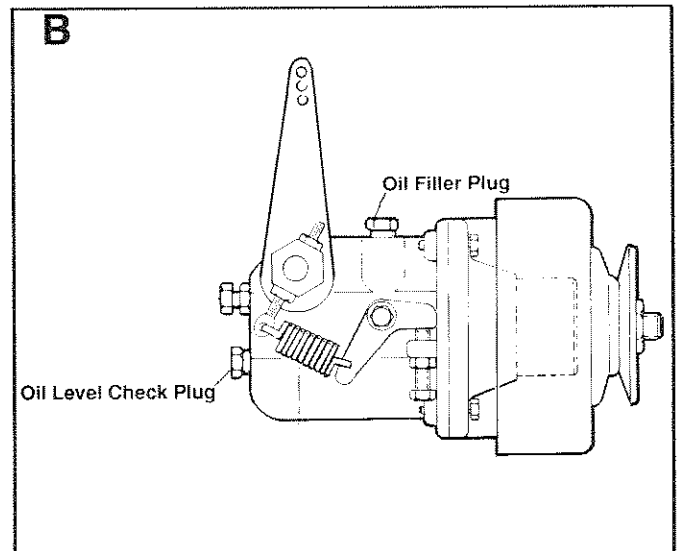

4.4.5- Governor Lever, Links and Spring

C The GOVERNOR LEVER (Item 52) is retained to the GOVERNOR SHAFT (Item 25) by a ROLL PIN (Item 17). When installing governor lever to carburetor linkage, set length of link to 4-3/8 inches (measured between ball joint centerlines).

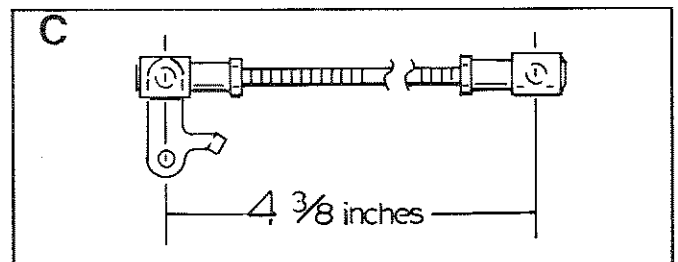

EXPLODED VIEW OF GOVERNOR ASSEMBLY

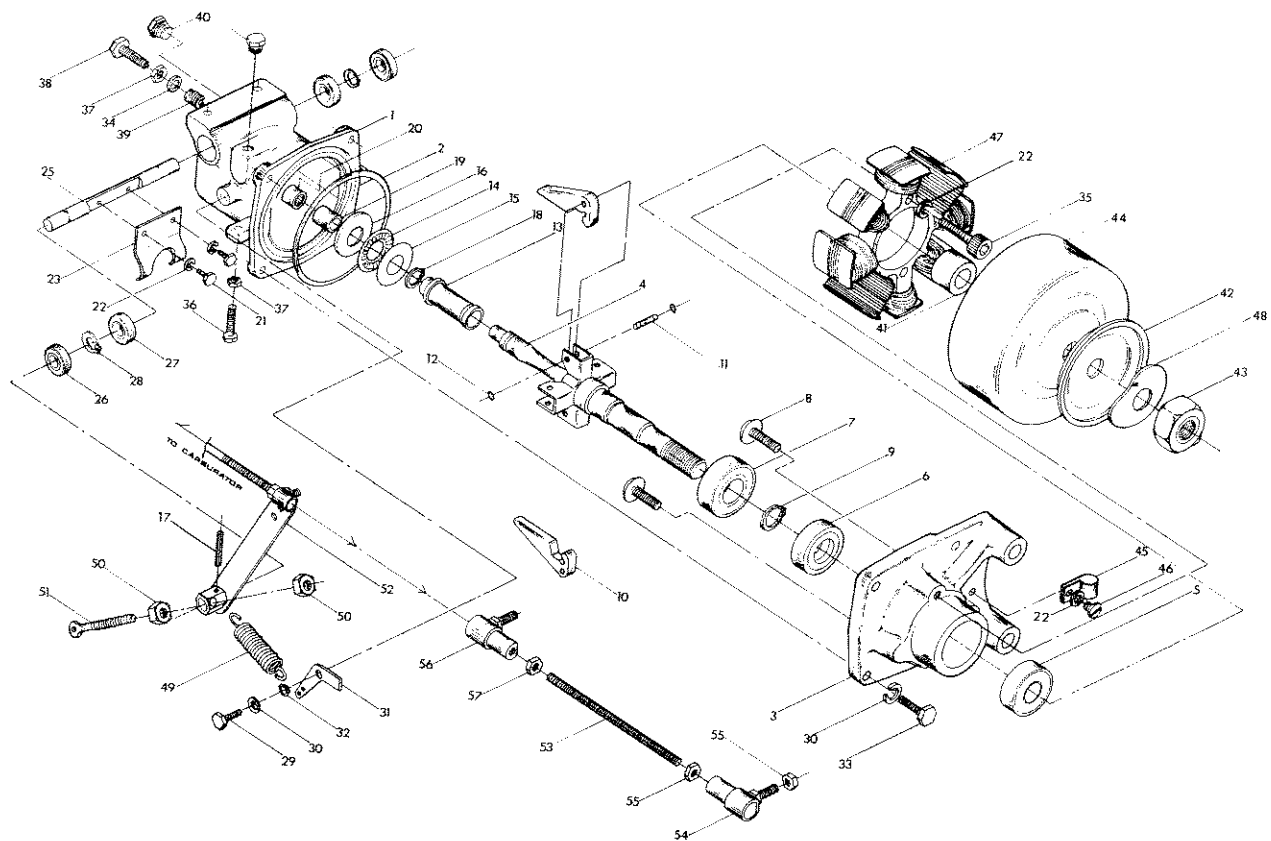

REF. NO.	DESCRIPTION	REF. NO.	DESCRIPTION
1	GOVERNOR HOUSING	29	HEX SCREW- M6-1.00
2	O-RING	30	LOCKWASHER- M6
3	OVERNOR FLANGE	31	TENSION BRACKET
4	DRIVE SHAFT ASSY	32	TENSION BRACKET BUSHING
5	BALL BEARING	33	HEX SCREW- M6-1.00
6	OIL SEAL	34	SEALING WASHER
7	BALL BEARING	35	SOCKET HEAD SCREW- M4-0.70
8	TRUSS HEAD SCREW	36	HEX SCREW- M6-1.00
9	EXT. RETAINING RING	37	NUT- M6-1.00
10	FLYWEIGHT	38	BUMPER SCREW
11	DOWEL PIN	39	COMPRESSION SPRING
12	EXT. RETAINING RING	40	PIPE PLUG- 1/8" NPT
13	THRUST SLEEVE	41	SPACER
14	NEEDLE BEARING	42	PULLEY HALF
15	THRUST WASHER	43	HEX JAM NUT
16	THRUST WASHER	44	D-C ALTERNATOR
17	ROLL PIN	45	CABLE CLAMP
18	EXT. RETAINING RING	46	PAN HEAD SCREW- M4-0.70
19	INNER RING BUSHING	47	D-C STATOR ASSY
20	BEARING DRAW CUP	48	WAVE WASHER
21	HEX SCREW- M4-0.70	49	TENSION SPRING
22	LOCKWASHER- M4	50	HEX NUT- M6-1.00
23	YOKE	51	SCREW- M6-1.00
25	ROCKER SHAFT	52	GOVERNOR LEVER
26	OIL SEAL	53	GOVERNOR/CARB. LINK
27	BALL BEARING	54	BALL JOINT
28	EXT. RETAINING RING	55	FLANGED LOCK NUT- No. 10-32

Section 5.1 - Ignition System General

5.1.1- Components

5.1.2- Operation

5.1.3- Service Data and Specifications

Section 5.2 - Tests, Checks and Adjustments

5.2.1- Ignition Coil Resistance

5.2.2- Checking the Condensor

5.2.3- Inspect Distributor Cap and Rotor Head

5.2.4- Contact Points

5.2.5- Check Governor Advance

5.2.6- Checking and Replacing Spark Plugs

5.2.7- Checking Ignition Wires

5.2.8- Ignition Timing

PART 5

ENGINE IGNITION SYSTEM

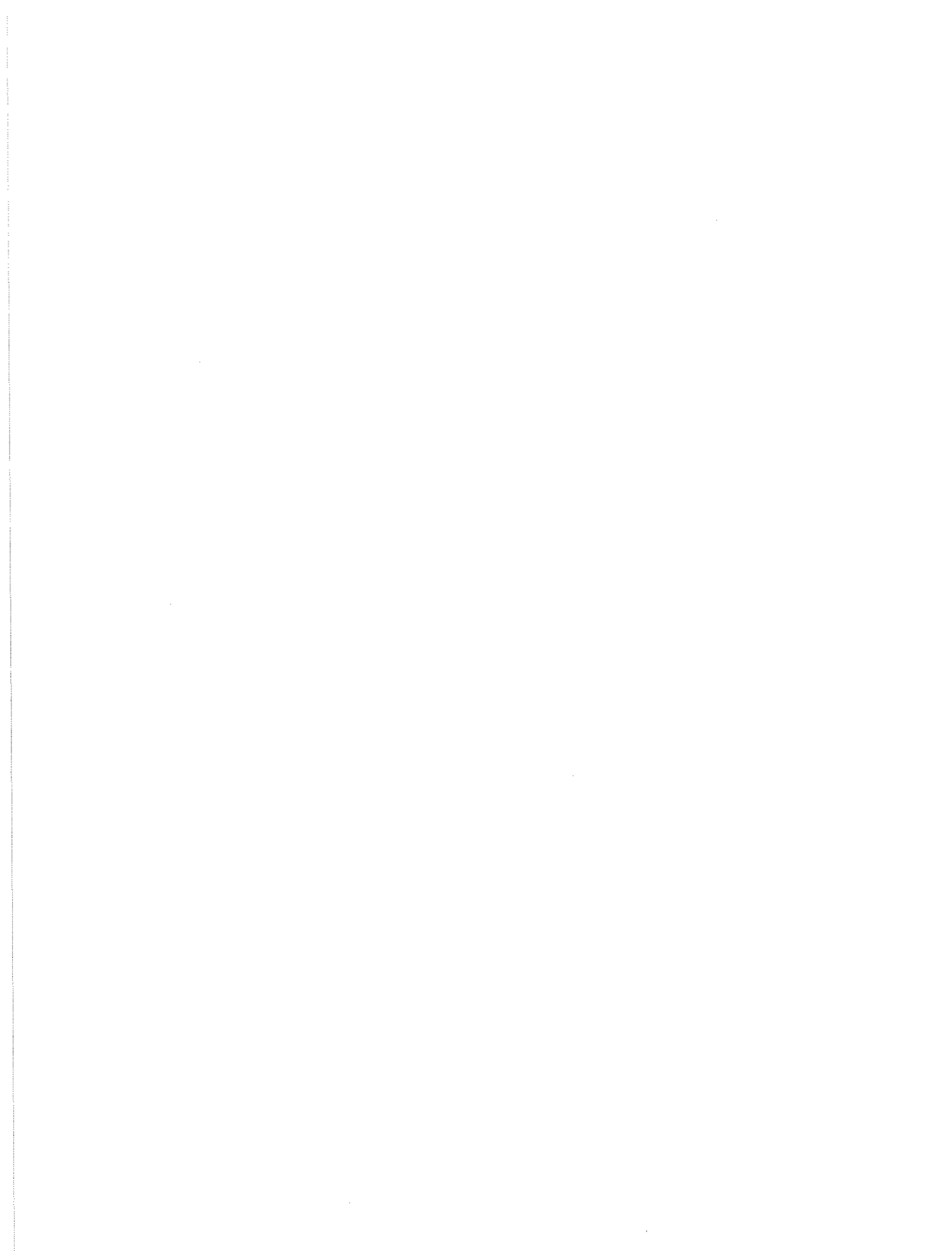

SECTION 5.1 - IGNITION SYSTEM GENERAL

5.1.1- Components

The ignition system consists of (a) an ignition coil, (b) a distributor, (c) spark plug wires, (d) spark plugs, and (e) a resistor.

5.1.2- Operation

Fused battery voltage is available to Terminal 1 of an ENGINE CONTROL circuit board, via Wire #13, a 10 amp circuit breaker, Wire #15A, a 20 amp fuse, and Wire #15. During engine cranking and operation, ENGINE CONTROL circuit board action delivers that battery voltage (+12 volts d-c) to the ignition coil, via Wire #14 and a resistor wire. The +12 volts d-c current flows through the ignition coil primary winding and to the distributor contact points. During contact points closure, current flows to frame ground. On opening of the distributor contact points, the magnetic field collapses to induce a high voltage into the ignition coil secondary coil which is distributed to the correct spark plug by distributor rotor action.

5.1.3- Service Data and Specifications

Firing Order.....	1-3-4-2
Distributor Rotation	Counterclockwise
Point Gap	0.018-0.022 inch
Cap Insulation Resistance.....	More than 50 meg-ohms
Rotor Head Insulation Resistance	More than 50 megohms
Cap Carbon Point Length	More than 0.012 inch (3mm) protruded length
Ignition Coil Resistance	
Primary Coil	1.3-1.5 ohms
Secondary Coil	8.7-11.7 k-ohms
Spark Plugs	
NGK	BPR6ES
Champion.....	RN9YC
AC	R42XLS
Spark Plug Gap.....	0.031-0.035 inch
Condenser Capacity	0.2-0.24 micro-farads

IGNITION SYSTEM WIRING DIAGRAM

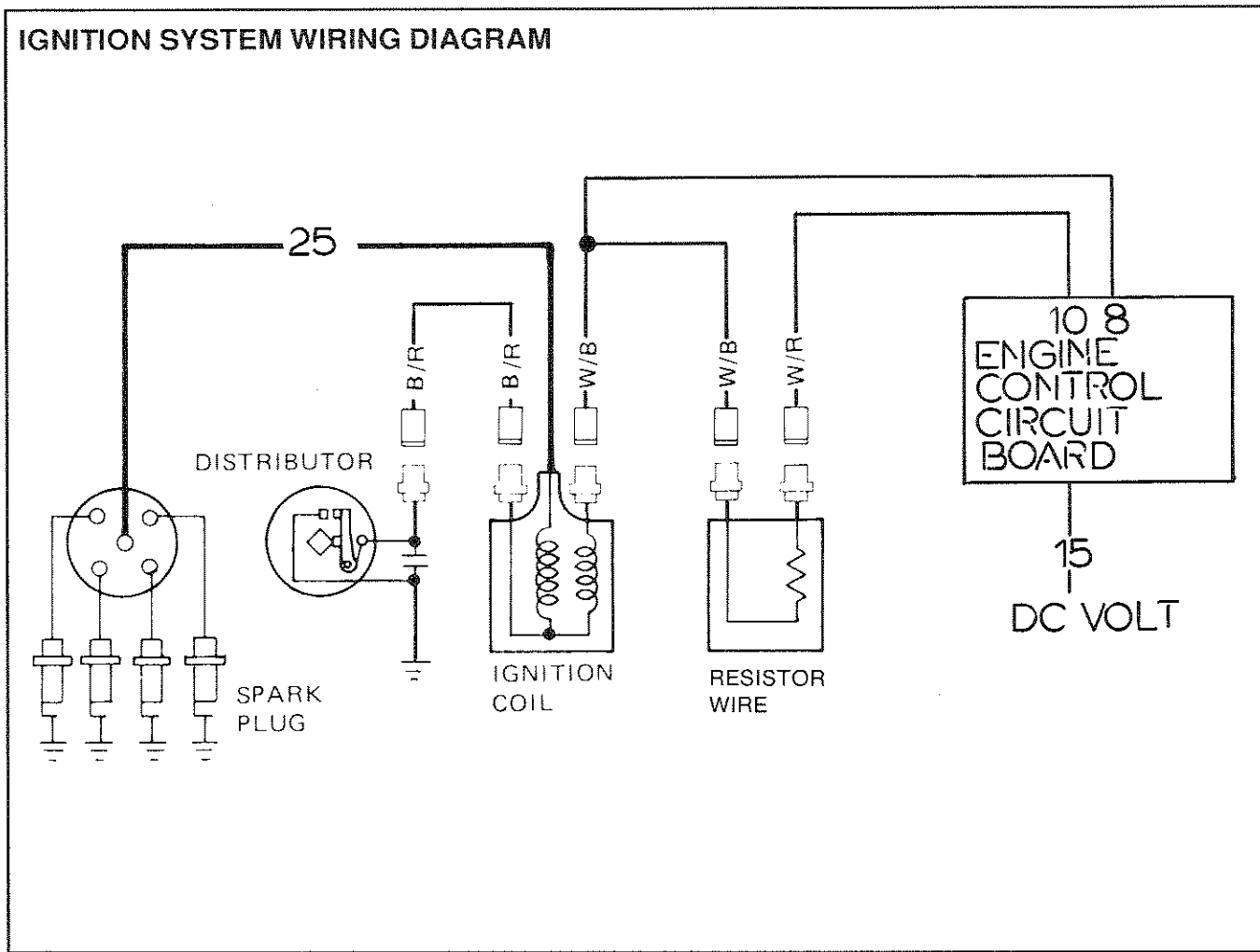

DISTRIBUTOR COMPONENTS

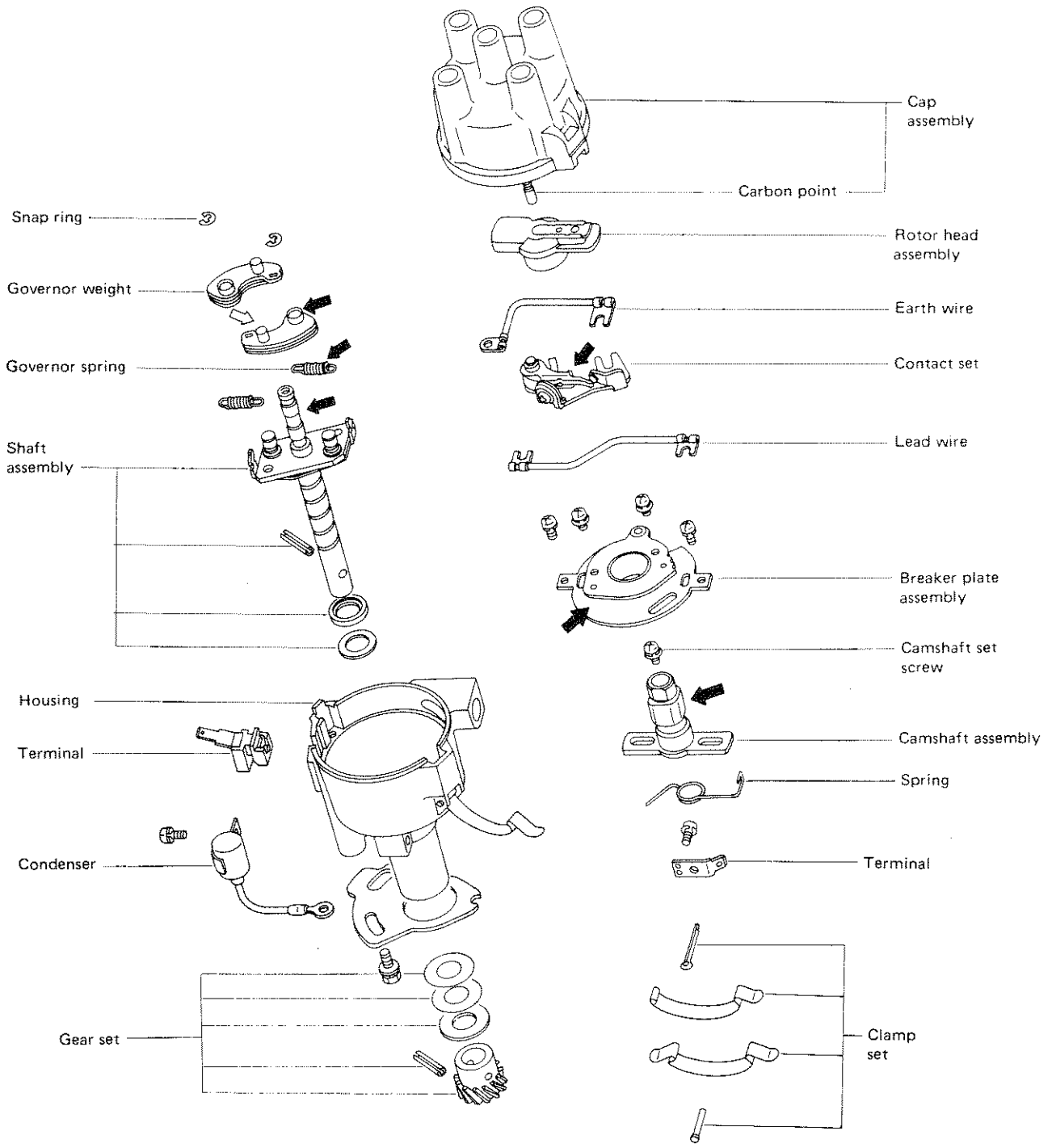

← : High-temperature grease point

SECTION 5.2 - TESTS, CHECKS AND ADJUSTMENTS

5.2.1- Ignition Coil Resistance

A Connect test probes of an ohmmeter across the positive and negative primary winding terminals of the ignition coil and measure the resistance.

Primary Winding Resistance at 68° F. (20° C.): - 1.3-1.5 ohms

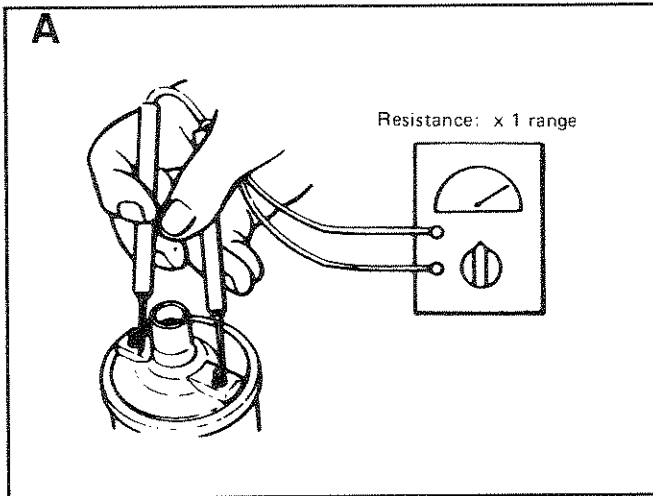

B Connect ohmmeter test probes to secondary winding terminal and to primary winding negative (-) terminal, and measure the resistance.

Secondary Winding Resistance at 68° F. (20° C.): - 8700-11,700 ohms

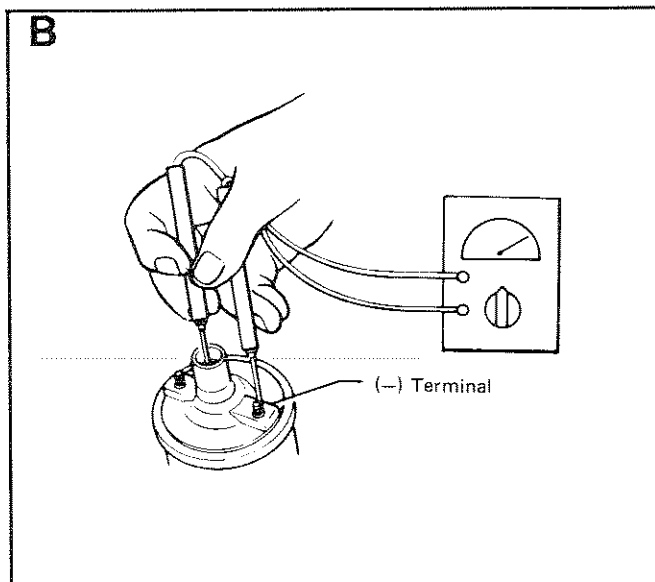

5.2.2- Checking the Condensator

Use a capacity tester to check the condensator. If a capacity tester is not available, the condensator may also be tested using a volt-ohm-milliammeter with its range set to high resistance reading. When the tester needle swings violently and then moves back to infinity gradually, the condensator is good. If tester needle indicates a steady reading or if it reads zero, the condensator should be replaced.

5.2.3- Inspect Distributor Cap and Rotor Head

Inspect cap and rotor head for dust, carbon deposits and cracks.

5.2.4- Contact Points

C Inspect surfaces of contact points. Irregularities may be removed with No. 500 or 600 sandpaper or with oilstone. Loosen breaker point set screw and adjust gap with a feeler gauge.

Points Gap: - 0.018-0.022 Inch (0.45-0.55mm)

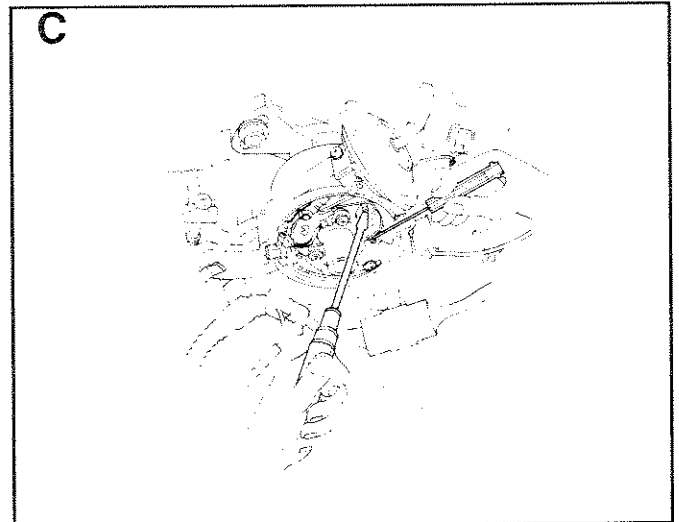

5.2.5- Check Governor Advance

D Turn rotor shaft counterclockwise, then release it and check that it returns to the clockwise direction. Also check that the rotor shaft is not excessively loose.

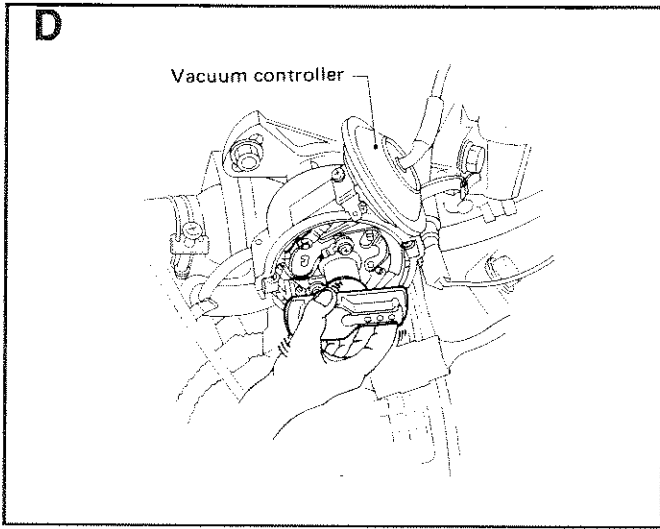

G Clean spark plugs in a sand blast cleaner. Inspect insulators for cracks, chipping. Inspect gasket for damage or deterioration. Inspect electrode for wear, burring, pitting. Replace plug(s) if defective. Check spark plug gap.

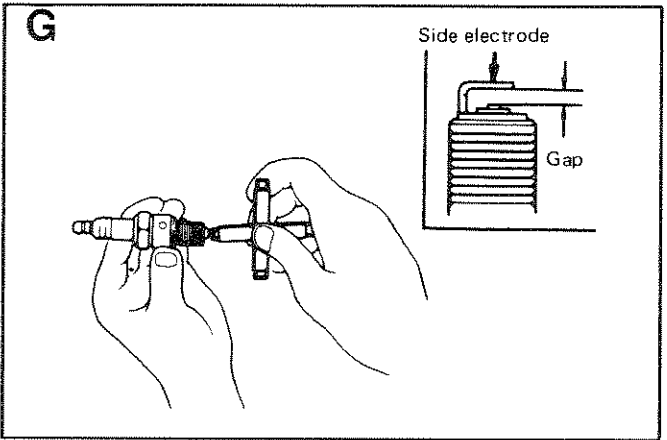

5.2.6- Checking and Replacing Spark Plugs

E Disconnect spark plug wires at boot. Do not pull on the wires.

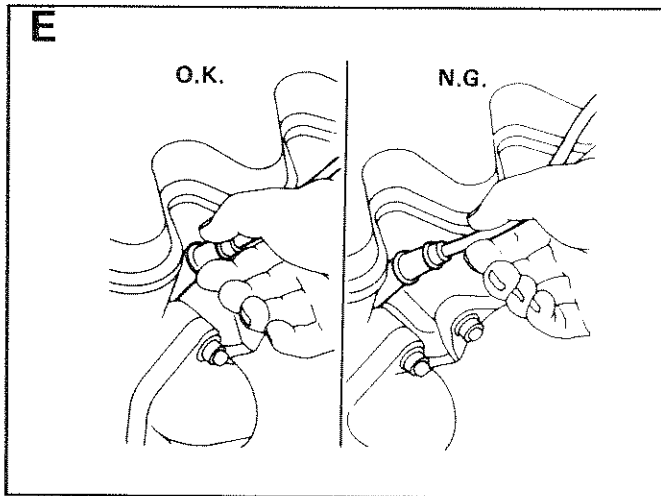

Install spark plugs and tighten to 14-22 foot-pounds torque (20-29 N-m). Reconnect spark plug wires.

5.2.7- Checking Ignition Wires

H Check high tension wires for damage, cracks, burned terminals, proper fit. Measure resistance of each wire. Shake wires during the resistance test. Resistance should be less than 30,000 ohms.

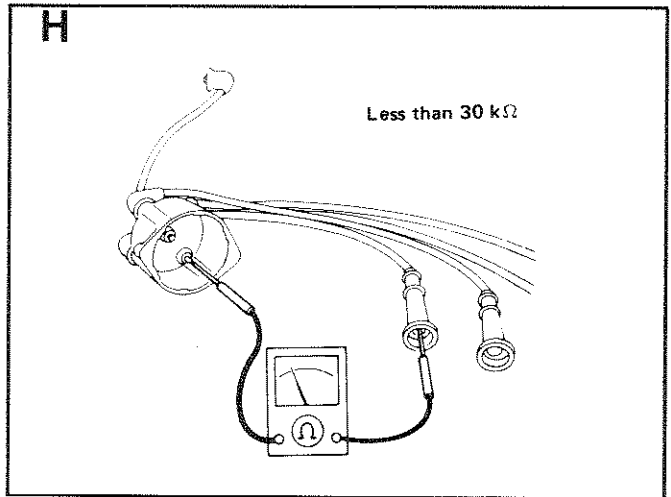

F Use a spark plug wrench to remove spark plugs.

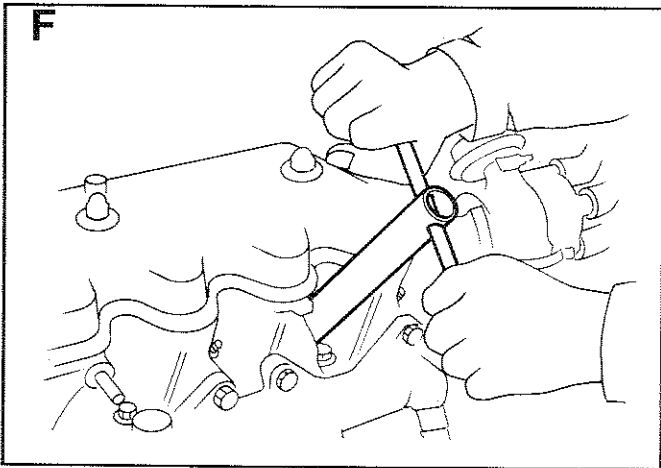

5.2.8- Ignition Timing

J Use an automotive timing light to check and adjust timing. A timing mark is provided on the crankshaft pulley and a degree indicator is also provided. Set timing as follows:-

Ignition Timing at 1860 rpm and at No-Load:- 21° BTDC

J Ignition Timing Adjustment

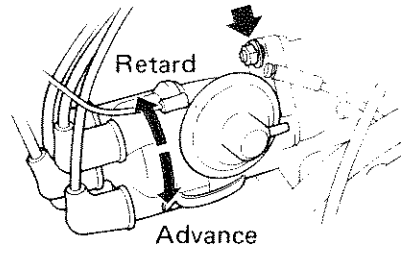
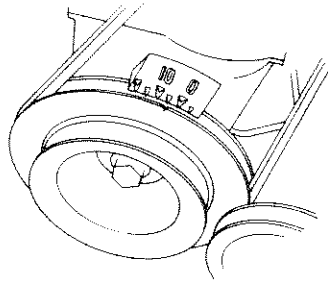

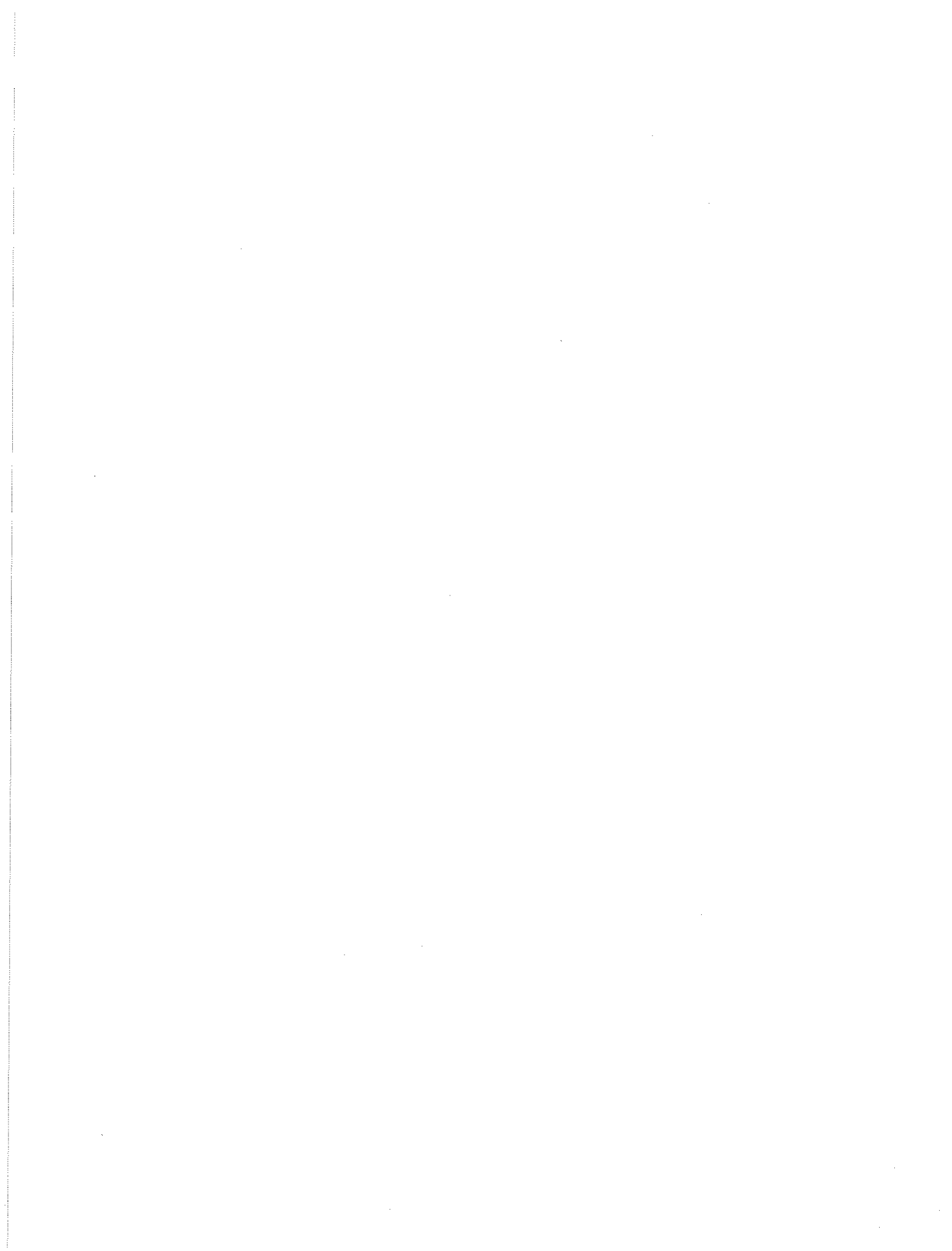

Section 6.1 - Engine Exhaust System

- 6.1.1- Exhaust System Installation
- 6.1.2- Typical Exhaust System Installations
- 6.1.3- The Siphon Break
- 6.1.4- Operating an Uninstalled Engine

PART 6

ENGINE EXHAUST SYSTEM

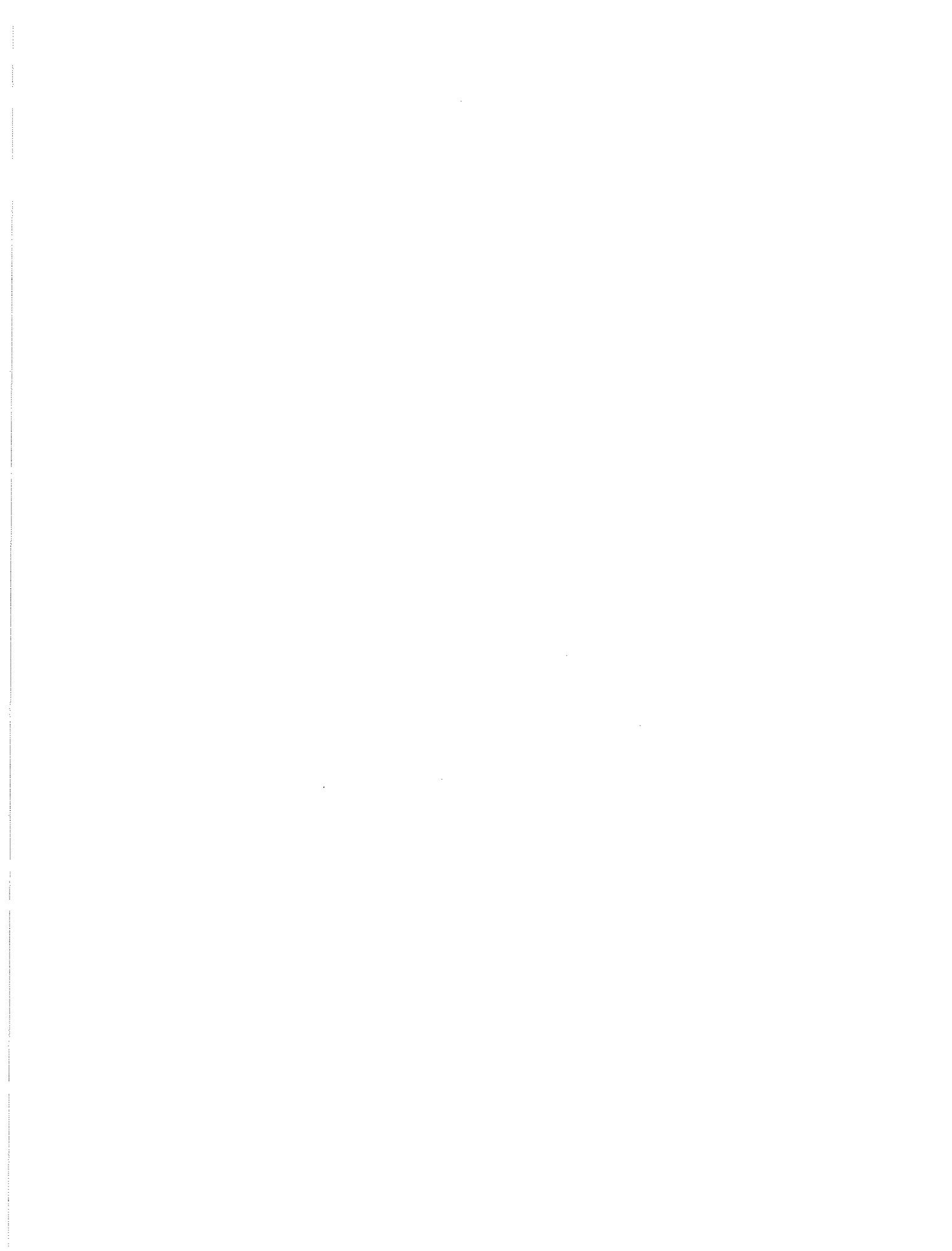

SECTION 6.1 - ENGINE EXHAUST SYSTEM

▲ DANGER

Exhaust gases contain DEADLY carbon monoxide gas, an odorless and colorless gas formed during the combustion of hydrocarbon fuels. DO NOT operate the marine generator engine if the exhaust system is leaking or has been damaged. Carbon monoxide gas can cause unconsciousness or even death. Symptoms of carbon monoxide poisoning are (a) inability to think coherently, (b) vomiting, (c) twitching muscles, (d) throbbing in temples, (e) dizziness, (f) headache, (g) weakness or sleepiness. If any of these symptoms are experienced, move into fresh air immediately. If symptoms persist, get medical attention. Never operate the marine generator engine unless exhaust gases are piped safely away and to an area not inhabited by people.

6.1.1- Exhaust System Installation

* When the marine generator is installed in a vessel, the exhaust system must comply fully with U.S. Coast Guard (USCG), National Fire Protection Association (NFPA), and American Boat and Yacht Council (ABYC) requirements. If you are servicing or repairing an installed generator set, never do anything that might tend to place the installation into non-compliance with such requirements.

* In an installed system, sea water must not be able to enter the engine exhaust manifold and cylinders while the vessel is underway, heeling, backing down, or any other underway conditions.

* The installed exhaust system must be TIGHT and completely FREE OF LEAKS.

* Exhaust piping and hoses must be of adequate size (diameter) to prevent excessive back pressure on the engine. The number of exhaust fittings and elbows must be kept to a minimum, since they will tend to create back pressure.

* Exhaust piping between the engine exhaust outlet fitting and the exhaust muffler must be at least as large as the exhaust outlet fitting. For every 10 running feet of exhaust pipe, an increase in diameter of one standard pipe size is recommended.

* If exhaust piping runs in a vessel are excessively long, back pressure should be checked. Back pressure should not exceed 1.2 inches of mercury (Hg) (30mm or 4 kPa).

* Never combine the generator's exhaust system with the exhaust from another engine.

* Install an approved, flexible length of exhaust pipe between the generator and any rigid exhaust piping. This will permit engine vibration and movement without breakage.

* Exhaust outlets in any vessel should be placed aft of sink, shower, and other cabin drains, to prevent backflow of exhaust gases through such openings.

* When installing or replacing exhaust system hoses, use piping and hoses recommended by the ABYC (Safety Standards for Small Craft).

6.1.2- Typical Exhaust System Installations

Two typical exhaust system installations are shown in the illustrations on next page.

A Exhaust Outlet Fitting on Engine is Above the Water Line

B Exhaust Outlet Fitting on Engine is Below the Water Line

6.1.3- The Siphon Break

C When an installed generator's exhaust outlet fitting is below the vessel's water line, a siphon break valve should be installed. The valve is a vacuum operated, anti-siphon valve that opens the exhaust line to atmosphere when the engine is shut down. The valve prevents sea water from being siphoned into the engine.

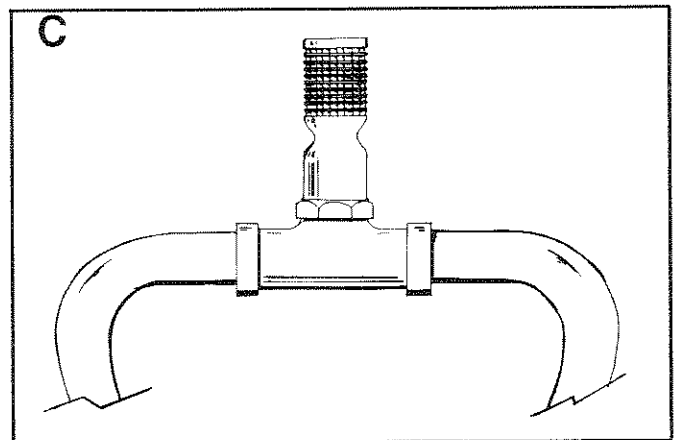

6.1.4- Operating an Uninstalled Engine

When operating an uninstalled engine, connect a suitable exhaust hose or piping to the engine exhaust outlet. Route the hose or piping to a safe area, where exhaust gases cannot accumulate and endanger people.

A Typical Installation with Exhaust Outlet Above the Water Line

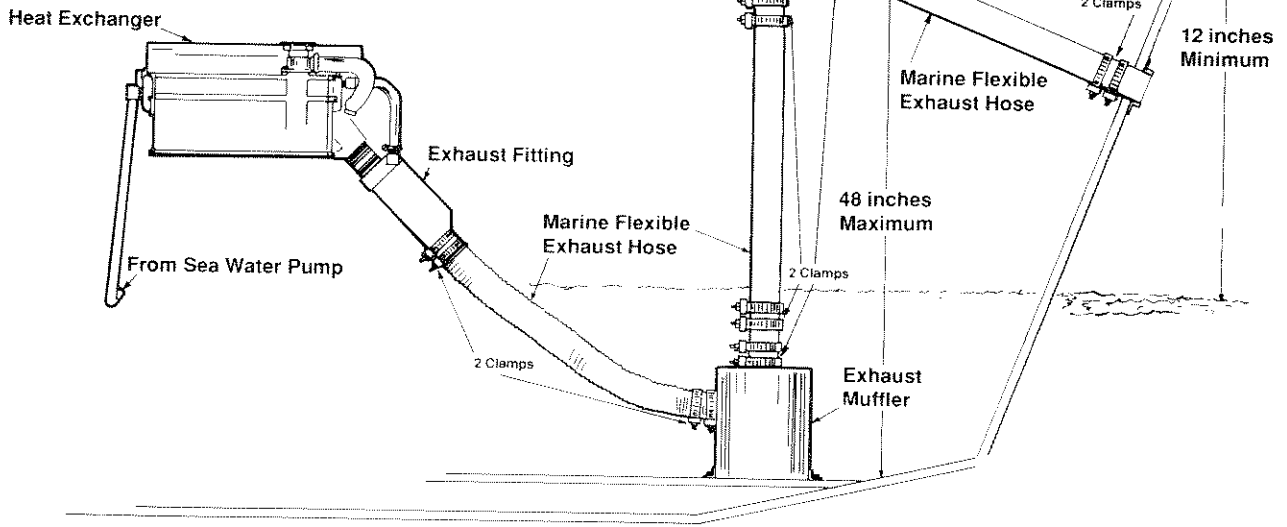
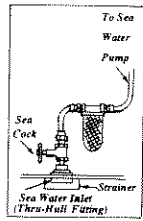

B Typical Installation with Exhaust Outlet Below the Water Line

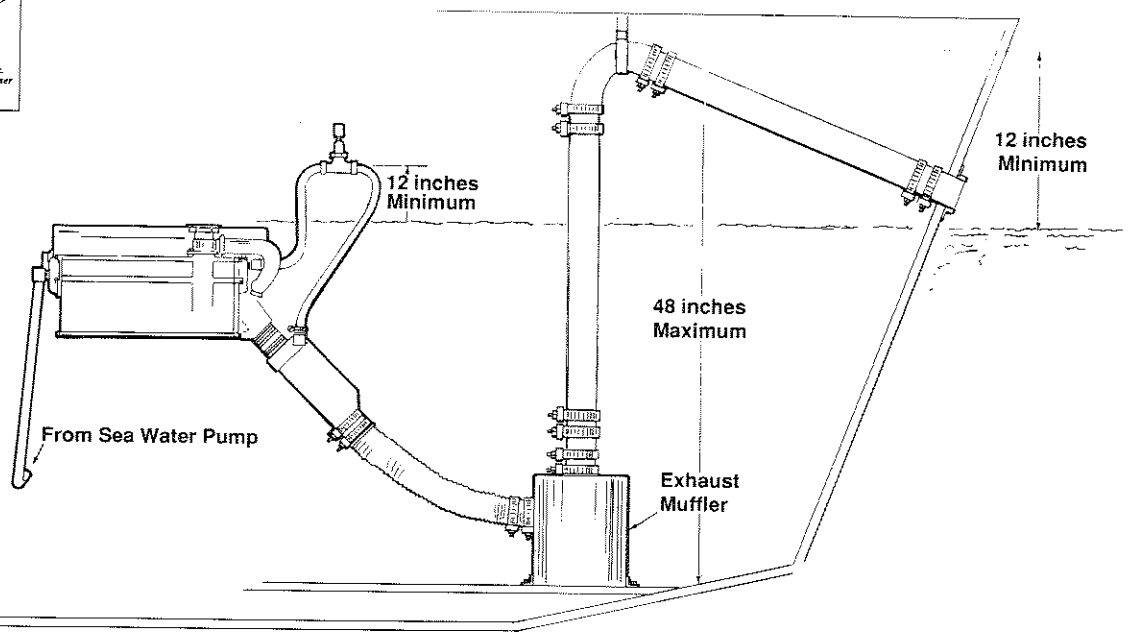
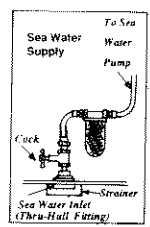

Section 7.1- Battery Charging System

- 7.1.1- Components
- 7.1.2- The d-c Alternator
- 7.1.3- Voltage Regulator

Section 7.2 - Engine Cranking System

- 7.2.1- Operation
- 7.2.2- Starter Motor Servicing Instructions
- 7.2.3- Starter Performance Test

Section 7.3 - Engine Control Circuit

- 7.3.1- Engine Control Circuit Board
- 7.3.2- Circuit Operation

Section 7.4 - Engine Electrical System Troubleshooting Guide

PART 7

ENGINE ELECTRICAL SYSTEM

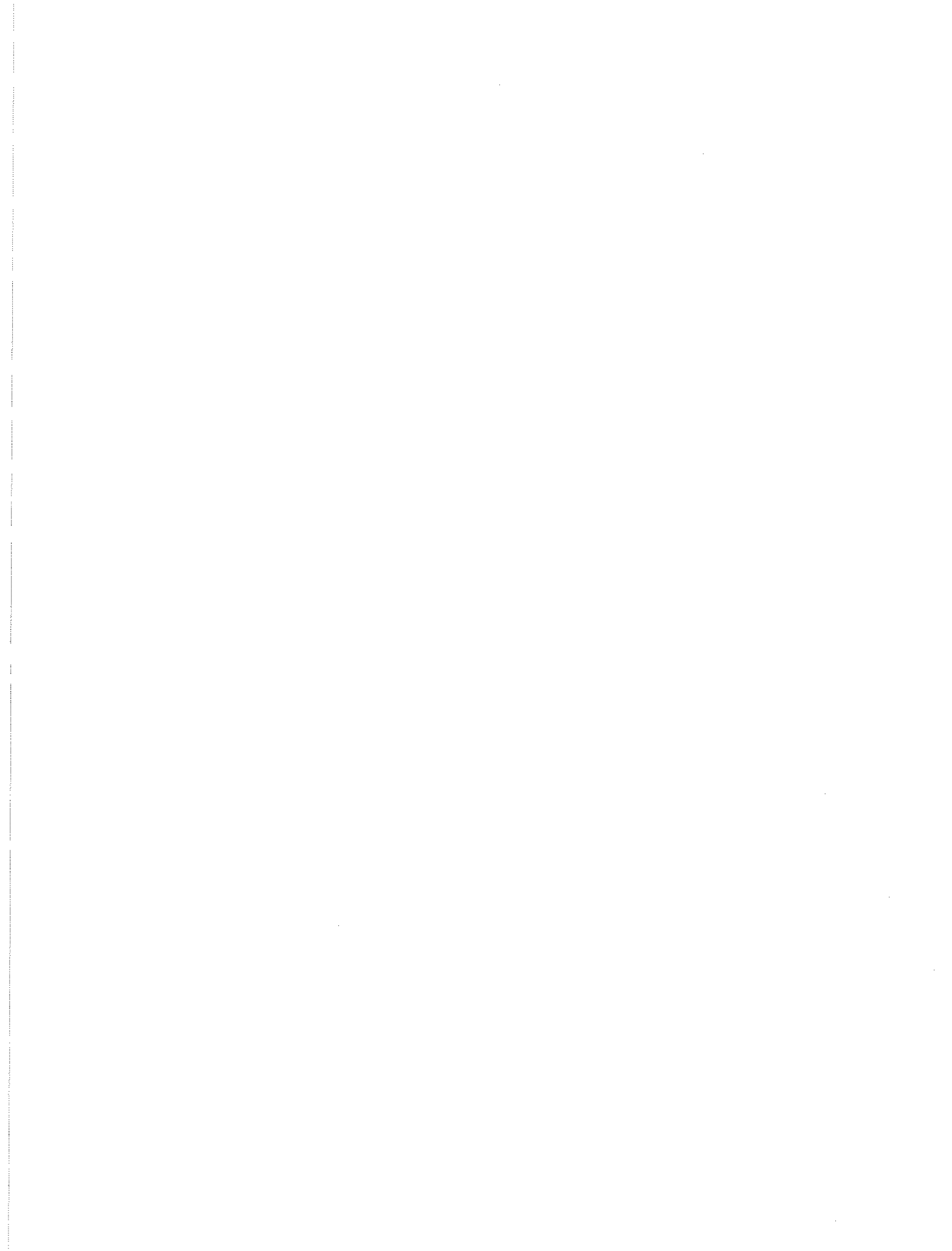

SECTION 7.1 - BATTERY CHARGING SYSTEM

7.1.1- Components

A A d-c ALTERNATOR supplies charging voltage to the battery during engine operation, as regulated by a d-c VOLTAGE REGULATOR. The circuit is protected by a 30 amp FUSE. The regulated charging current is delivered to the unit 12 volts battery, via Wire #13A, the fuse, Wire #13, the STARTER CONTACTOR terminal stud, and the positive (+) battery cable.

7.1.2- The d-c Alternator

The belt driven, permanent magnet type d-c alternator is attached to the engine speed governor (Section 4.4). Maintenance on the alternator is limited to replacement of defective parts. Removal of alternator parts from the governor is covered in Paragraph 4.4.3.

7.1.3- Voltage Regulator

The solid state d-c voltage regulator is housed in an aluminum heat sink with all components covered with epoxy resin. The regulator is not repairable. Regulator connector pins are numbered from left to right as follows:-

- Pin 1 - Charging output to battery (12.5-14.5 volts d-c)
- Pin 2 - Charging input from d-c alternator
- Pin 3 - Charging input from d-c alternator
- Pin 4 - Not Used (Charge indicating lamp connection)
- Pin 5 - Sensing voltage from battery (Wire #15)

IMPORTANT: The d-c alternator delivers alternating current (a-c) to the voltage regulator. Rectification (conversion to direct current) is done within the voltage regulator.

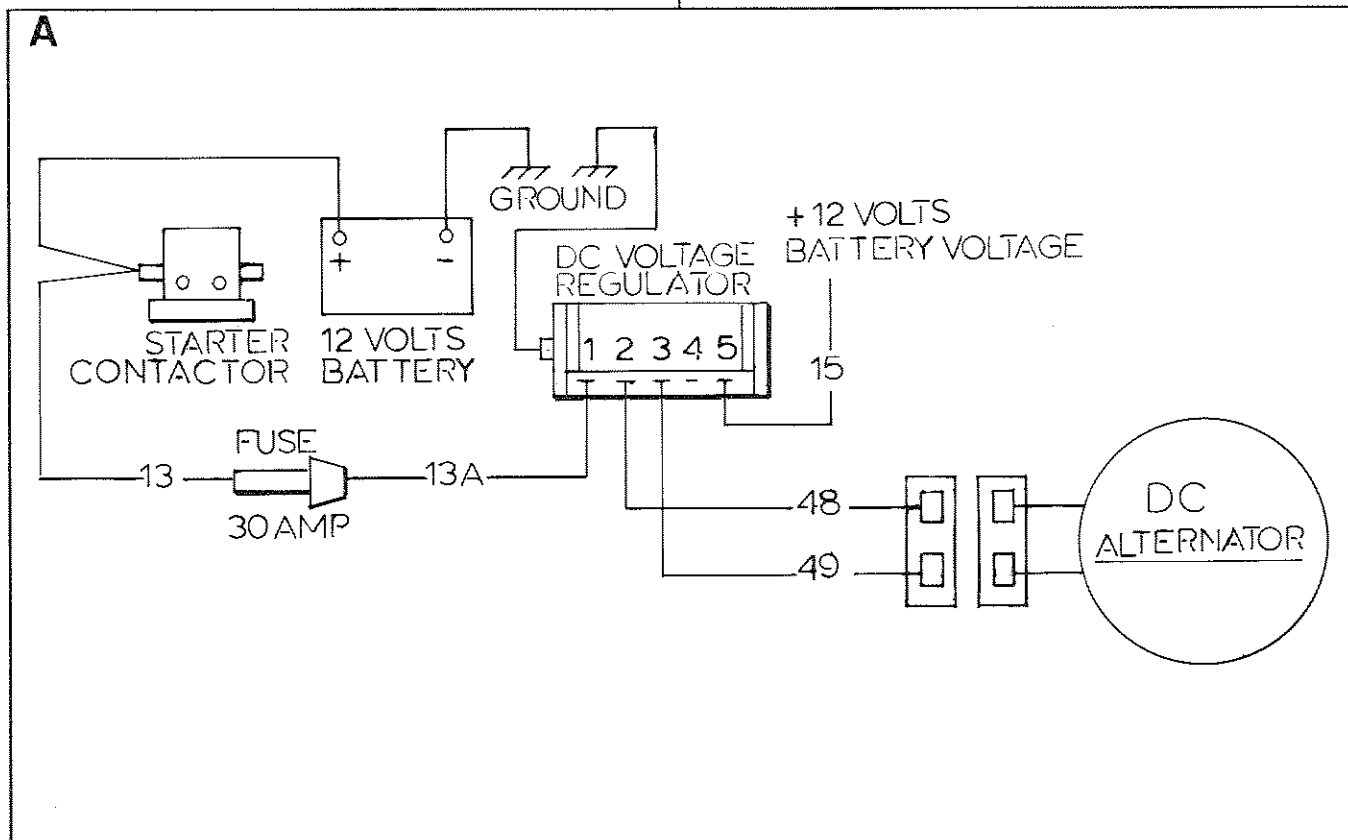

SECTION 7.2 - ENGINE CRANKING SYSTEM

7.2.1- Operation

The battery positive (+) cable is connected to one of the large terminal studs on the starter contactor. During engine startup, the starter contactor (SC) is energized by ENGINE CONTROL circuit board action, i.e., +12 volts d-c is applied to the starter contactor via Wire #56. Battery output is then delivered to the starter assembly and to the automatic choke circuit via Wire #16. The engine cranks. When the Start/Stop switch is released by the operator, ENGINE CONTROL circuit board action opens the Wire #56 circuit to the starter contactor and cranking terminates.

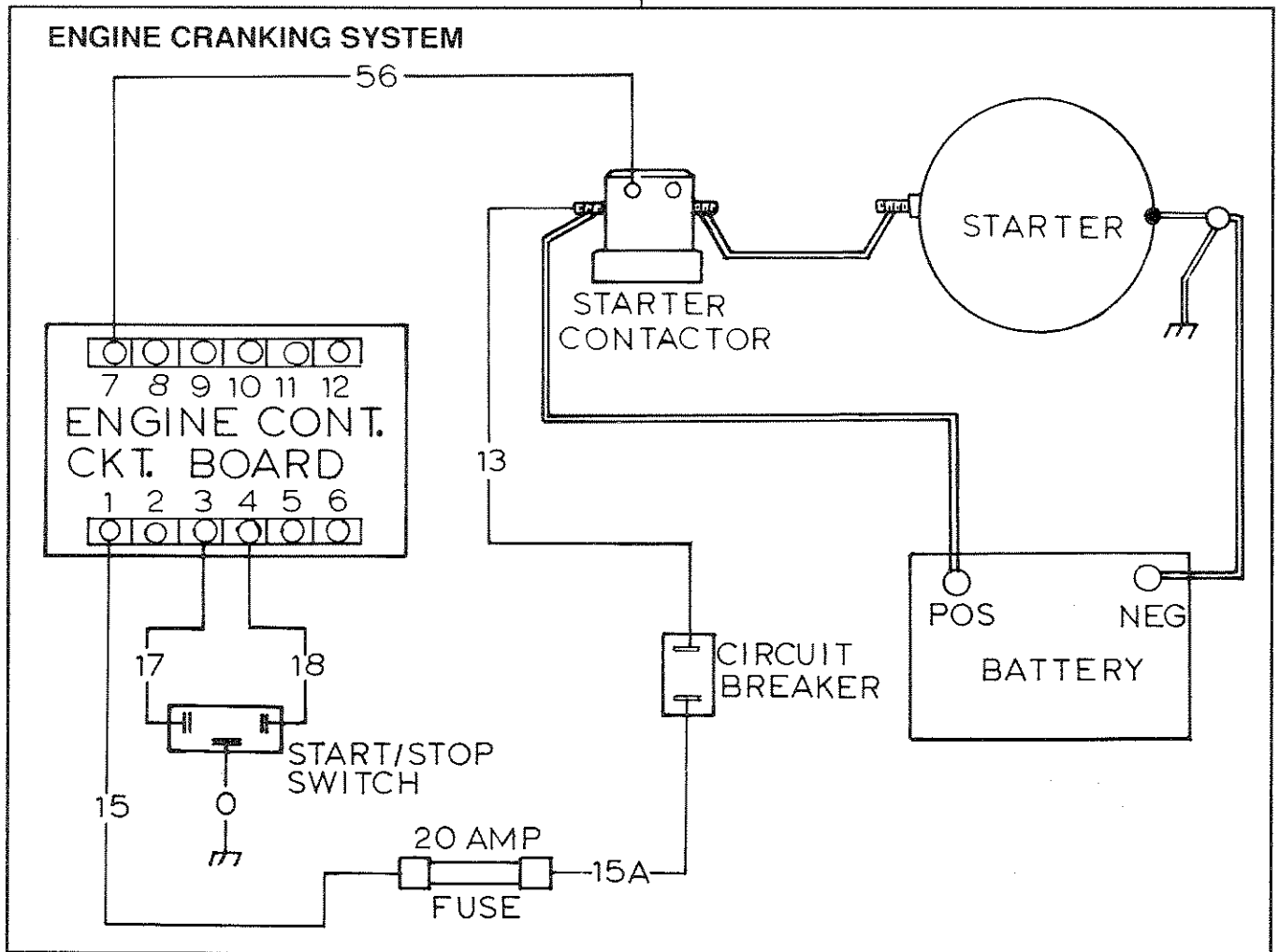

STARTER ASSEMBLY EXPLODED VIEW

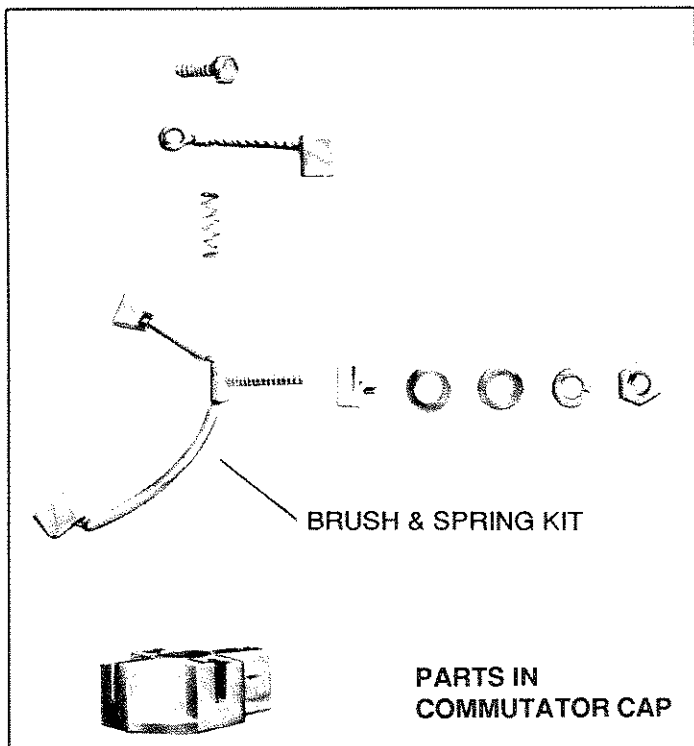
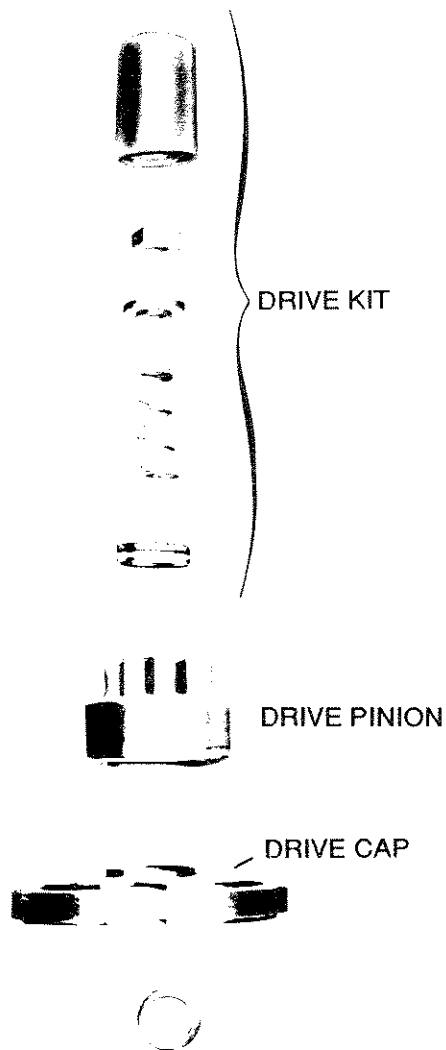
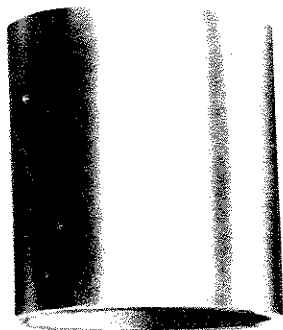

COMMUTATOR CAP

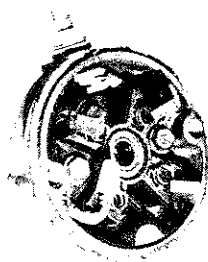

THRU BOLTS

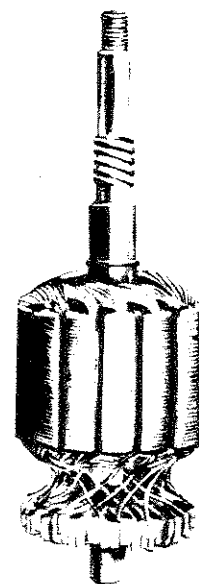

ARMATURE ASSEMBLY

7.2.2- Starter Motor Servicing Instructions

Rated Voltage:- Starter motor is rated 12 volts d-c. The voltage applied to the starter motor should never exceed the rated voltage, or magnets in the motor may become demagnetized.

Inspection:- Check for adverse wear on all bearings, gears, shafts, etc. Check spring washer for wear, convex side next to bearing. Add a drop of oil to face of bearing.

Thru-Bolts:- Tighten thru-bolts to 75 inch-pounds.

Drive Cap:- Apply a film of SAE #10 oil to the bearings in the drive cap. During reassembly, the insulating washer must be placed against the drive cap.

Brush Assembly:- Brushes and brush springs should be replaced at each overhaul. Any brush that is worn to 5/16 inch (or less), measured on the short side of the brush, or that has been in contact with grease, oil, or cleaning fluid must be replaced. Assemble brushes with their chamfered side away from the springs. Torque the brush screw to 30-35 inch-pounds. Tighten the hot stud nut to 45-50 inch-pounds.

Armature:- Check the armature for a ground, open or shut, with a growler. Hold armature in a vise when installing or removing the drive assembly. Apply a thin film of Quicksilver non-conducting grease to the commutator end of the armature shaft and to the portions of the shaft that contact the bearings.

7.2.3- Starter Performance Test

CAUTION

Do not operate the starter motor continuously for longer than 30 seconds when testing.

Use a fully charged, 12 volts battery connected as follows:

1. Positive (+) terminal to the starter motor input stud
2. Negative (-) terminal to the starter motor housing

Use a No. 10 cable (or larger), not over 6 feet in length.

Maximum current draw and starter speed should be as follows:

17 amps at 6000-7200 rpm

SECTION 7.3 - ENGINE CONTROL CIRCUIT

7.3.1- Engine Control Circuit Board

A A solid state circuit board controls all engine starting, running and stopping functions. The board receives a +12 volts d-c input for control of those functions (Wire #15). Circuit board terminals and connecting wires are listed in the CHART on this page.

NOTE: A complete WIRING DIAGRAM may be found on Page 19 of Part 1.

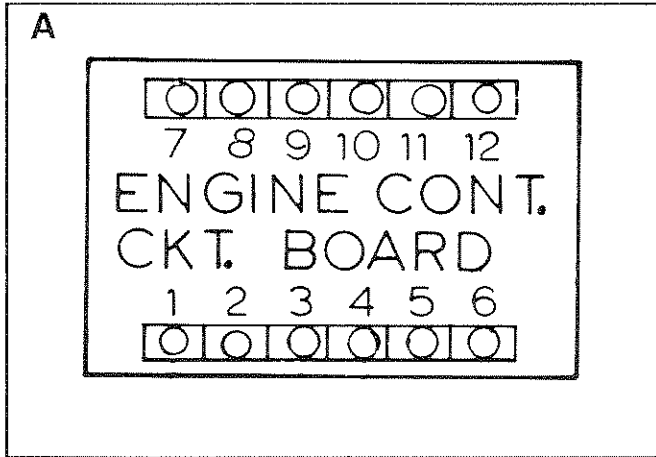

7.3.2- Circuit Operation

B Engine Shut Down:- Battery voltage is available to Terminal #1 of the Engine Control circuit board, via the positive (+) battery cable, Wire #13, a 10 amp Circuit Breaker, Wire #15A, a 20 amp Fuse, and Wire #15. In shutdown condition, circuit board action holds the circuit open (similar to an automotive ignition switch). It is important to note that, without battery voltage at circuit board Terminal #1, cranking and startup cannot occur.

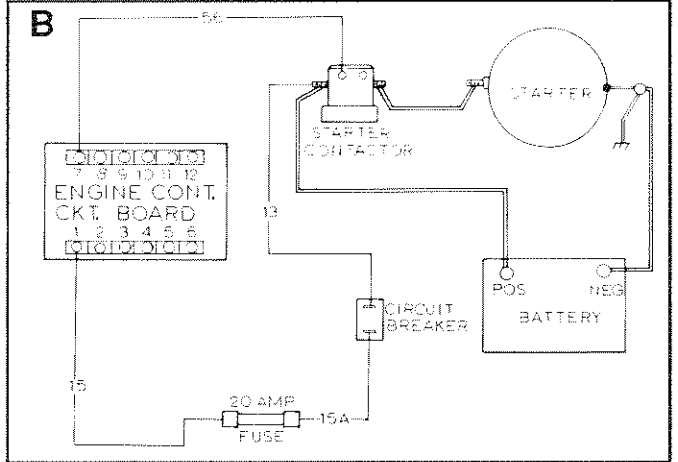

ENGINE CONTROL CIRCUIT BOARD TERMINAL IDENTIFICATION

TERMINAL	WIRE	DESCRIPTION OR FUNCTION
1	15	Fused battery voltage (+12 volts d-c)
2	0	Common Ground
3	17	Engine crank & start (Ground to crank engine)
4	18	Engine stop (Ground to shut down engine)
5 & 6	11, 22	Generator 120 volts a-c (frequency) sensing for automatic overspeed shutdown
7	56	+12 volts d-c to starter contactor (crank signal) with Start/Stop switch at START only
8	9	Engine ignition ground- terminates ignition when Start/Stop switch is set to STOP
9	14	+12 volts d-c to carburetor Fuel Solenoid during cranking and running only (opens Fuel Solenoid) - Also +12 volts d-c to automatic Choke Heater during cranking and running only
10	14	+12 volts d-c to Fuel Pump, Hourmeter and "Generator Run" lamp on optional remote start panel when running only
11	14	+12 volts d-c to engine ignition circuit when cranking and running only
12	85	Automatic protective shutdown circuit to High Exhaust Temperature, Low Oil Pressure and High Coolant Temperature switches - ground Wire #85 to stop engine

NOTE:- Wire #14 is electrically hot (+12 volts d-c) with engine running only.

C Initial Cranking:- Setting the Engine-Start/Stop switch (on generator panel or on a remote panel) to START position connects the Wire #17 circuit to frame ground (Wire #0). Engine Control board action then delivers +d-c voltage to the small terminal of the Starter Contactor, via Wire #56. The Starter Contactor energizes to deliver battery voltage to the Starter and the engine cranks. On closure of the Starter Contactor contacts, +d-c output is also delivered to a Choke Module (CM), via Wires #16 and #90. The Choke Module houses a solid state circuit which opens and closes the Wire #90 circuit at a rate dependent on ambient temperature. The Choke Solenoid (CS) then opens and closes the carburetor choke plate cyclically (about every 2 to 5 seconds).

IMPORTANT: The Choke Module (CM) also houses a Field Boost Diode and Resistor, will deliver a reduced battery voltage to the generator Rotor windings during cranking only. See Section 1.1.

D Startup and Running:- With engine cranking, Engine Control circuit board action will deliver +d-c voltage to all Wires #14. The carburetor Fuel Solenoid (FS) will open; the Fuel Pump (FP) will operate; ignition will occur. The engine will then start. When the Start/Stop switch is released, circuit board action will open the circuit to Wire #56. The Starter Contactor (SC) will then de-energize and cranking will terminate. In addition, automatic choke and field boost operations will cease.

IMPORTANT! On some installations, Wire #14 d-c output may also turn on an optional Hourmeter and a remote panel mounted "Generator Run" lamp.

E Normal Shutdown:- Setting the Start/Stop switch to STOP results in connection of Wire #18 to frame ground. Circuit board action then opens all Wire #14 circuits to terminate ignition, fuel pump operation, etc. Engine shutdown will then occur.

F Engine Fault Shutdown:- Wire #85 from the Engine Control circuit board connects to (a) a Low Oil Pressure Switch, (b) a High Water Temperature Switch, and (c) a High Exhaust Temperature Switch. These engine safety switches have normally-open contacts which will close on occurrence of the applicable engine fault. On contacts closure, Wire #85 will connect to frame ground and an automatic engine shutdown will occur.

IMPORTANT: Generator a-c frequency (speed) signals are delivered to the circuit board, via Wires #11 and #22. Should a-c frequency exceed approximately 70 Hz (60 Hz units) or 60 Hz (50 Hz units), an automatic overspeed shutdown will occur.

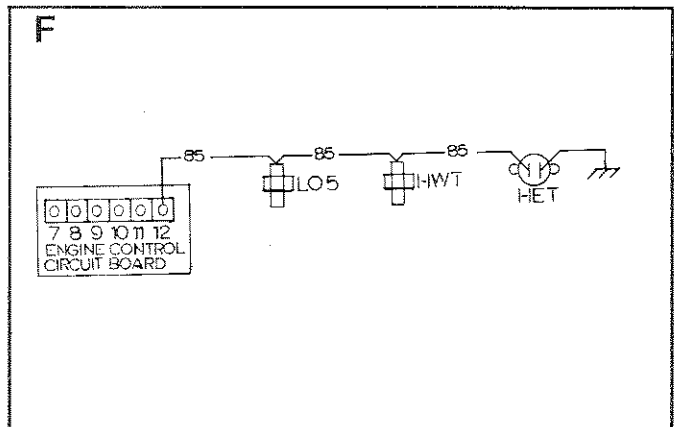
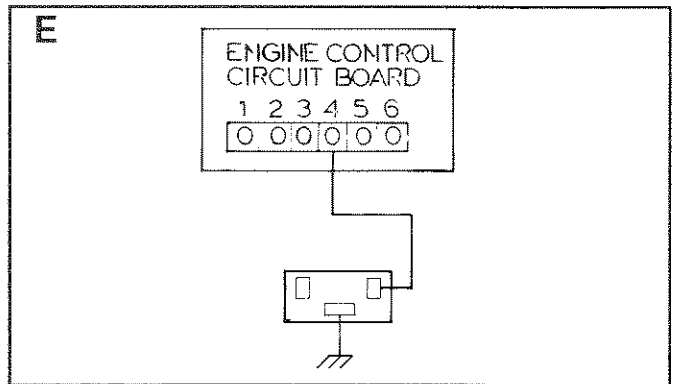
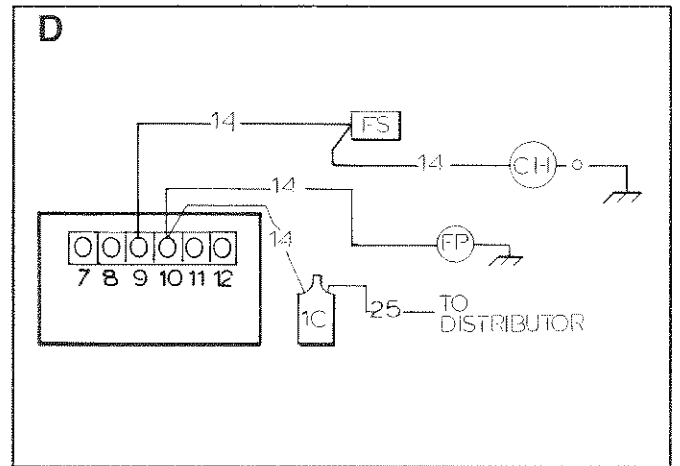
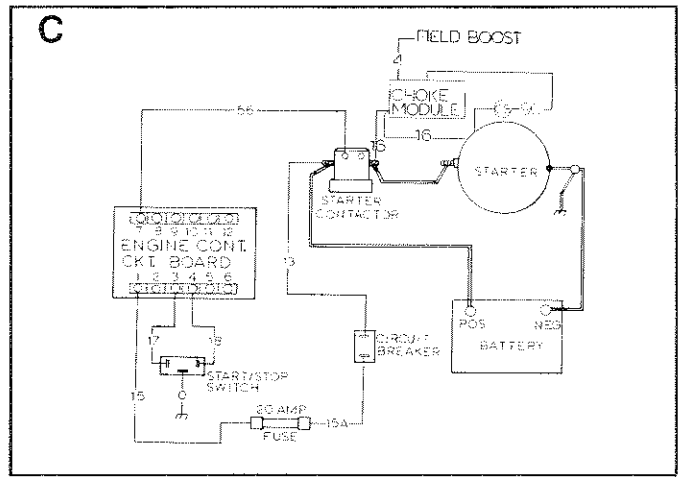

SECTION 7.4 - TROUBLESHOOTING GUIDE

7.4.1- General

The following guide is provided to assist the technician in locating and correcting causes of a problem in the engine electrical system. Follow the procedure carefully and perform each step in the exact order given. It is assumed that the troubleshooting technician has a working knowledge of d-c electrical circuits and how to test them.

7.4.2- If the Engine Won't Crank

If the engine won't crank when the Start/Stop switch is held at START, proceed as follows in the exact order each test is given:

A. Check the 10 amp Circuit Breaker:- Try resetting the "push-to-reset" type breaker. If breaker is reset and engine still won't crank, first check for +12 volts d-c at the breaker's Wire 13 terminal. Then, check for d-c volts at the breaker's Wire 15A terminal.

RESULTS:

1. Voltage present at Wire 13 terminal, but not at Wire 15A terminal of breaker..... Replace Circuit Breaker
2. Voltage is present at both terminals..... Go to Step B
3. No voltage at either terminal..... Go to Step C

B. Check the 20 Amp Fuse:- Remove fuse, inspect and/or test with an ohmmeter. If fuse element has melted open, replace with an identical 20 amp fuse.

RESULTS:-

1. Engine cranks normally..... Tests complete
2. Engine still doesn't crank..... Go to Step C

C. Check Battery and Battery Cables:- Use an automotive type battery hydrometer to test battery state of charge and condition. Follow the hydrometer manufacturer's instructions carefully. If specific gravity reading is less than 1.230, recharge the battery. If, after recharging battery, the difference in specific gravity reading between the lowest and highest cells is greater than 0.050 (50 points), the battery should be replaced.

Check all battery cables for tightness and corrosion. Clean or tighten as required.

D. Check Start/Stop Switch:- Disconnect Wire 17 from the Start/Stop switch. Hold the terminal end of that wire into firm contact with a clean frame ground. The engine should crank.

RESULTS:

1. Engine Cranks normally with Wire 17 grounded, but not with Start/Stop switch..... Replace Start/Stop Switch
2. Engine does not crank..... Go to Step E

E. Check Engine Control Circuit Board Power Supply:- Use a d-c voltmeter to test voltage at Pin #1 of the circuit board (Wire #15 connection). Battery voltage should be present at this pin.

RESULTS:

1. Voltage checks good..... Go to Step G
2. No voltage indication..... Go to Step F

F. Check Circuit Board Power Circuit:- Check the circuit which includes Wire 15, the 20 amp Fuse, Wire 15A, 10 amp Circuit Breaker, and Wire 13 back to the Starter Contactor connection. Any open condition in this circuit will result in loss of d-c power to the circuit board.

RESULTS:

1. Circuit is open..... Repair or replace defective wire or component(s)
2. Circuit checks Good..... Go to Step G

G. Check Crank Signal from Circuit Board:- Hold the Start/Stop switch at START while checking for +d-c voltage at Engine Control circuit board Pin #7 (Wire 56 connection). If d-c voltage was available at Pin 1 (Step E) but is not available at Pin 7 in this test, the Engine Control circuit board has probably failed.

RESULTS:

1. +d-c voltage is indicated..... Go to Step H
2. No voltage indicated, but good voltage in Step E was read..... Replace Engine Control circuit board

H. Check Wire 56:- Hold the Start/Stop switch at START while checking for +d-c volts at the Wire 56 terminal of the Starter Contactor (large terminal stud).

RESULTS:

1. No voltage indicated..... Repair/replace Wire 56
2. Voltage checks good..... Go to Step J

J. Check Starter Contactor:- Check for battery voltage at the Wire 13 terminal (large stud) of the Starter Contactor. This is the battery side of the Contactor. Then, hold the Start/Stop switch at START while checking for battery voltage at the Wire 16 terminal stud (large stud).

RESULTS:

1. No battery volts at Wire 13 terminal..... Recheck battery and battery cable (Step C)
2. Voltage indicated at Wire 13 stud, but not at Wire 16 stud with switch actuated..... Replace Starter Contactor
3. Voltage good at both terminal studs..... Go to Step K

K. Check Starter:- Refer to Section 7.2 (Engine Cranking Circuit).

7.4.3- Engine Cranks But Won't Start

If the engine cranks but won't start, proceed as follows:

A. Check Fuel Supply:- On some installations, the generator fuel pickup tube may be shorter than the propulsion engine pickup tube. Thus, the generator will "run out of gas" while adequate fuel remains in the tank for the propulsion engine. Check fuel supply to the generator engine, fuel filters, any shutoff valves, etc.

B. Check Fuel Pump:- Disconnect fuel pump outlet line, crank engine and check fuel flow from pump. Also see Section 4.2.

C. Check Fuel Solenoid:- Remove Solenoid from engine carburetor. Hold the Solenoid housing into firm contact with a clean frame ground and set the Start/Stop switch to START. The Solenoid Valve tip should pull in. If it does not operate, replace the Solenoid. If the Solenoid works, install it and tighten before proceeding.

D. Check Automatic Choke Operation:- While cranking the Choke Solenoid should pull in about every 2 to 5 seconds. See Section 4.3.

E. Check Ignition Power Supply:- Locate the Wire 14 terminal at the Ignition Coil. Check for a +d-c voltage at that terminal while cranking engine. If no voltage is indicated, check Wire 14 between Ignition Coil and circuit board for open condition. Repair or replace wire, as needed.

F. Check Engine Ignition System:- Refer to Part 5 of Manual.

G. Check Engine Control Circuit Board:- While cranking engine, check for +d-c voltage at Pins 9, 10 and 11 of the circuit board. If no voltage is indicated, replace the circuit board.

H. Check Engine Compression:- See Part 2 of Manual.

7.4.4- Engine Starts Hard, Runs Rough

If engine starts hard and runs rough, refer to the appropriate parts of this manual and check the following:-

1. Check air intake system
2. Check automatic choke operation
3. Check carburetor adjustments
4. Check engine governor adjustment
5. Check engine ignition system
6. Check engine

7.4.5- Engine Starts But Shuts Down When Start/Stop Switch is Released

If engine cranks and starts, but shuts down as soon as the Start switch is released, the problem is probably in one of the engine protective devices. Check engine oil level, check engine oil pressure. Then, check the Low Oil Pressure, High Coolant Temperature, and High Exhaust Temperature switches for proper operation. Refer to the applicable sections for test procedures.

Marine Generator Specifications

Model QS-4.0G.....	1
Model QS-6.5G.....	2
Model QS-8.0G.....	3
General Engine Specifications.....	4

Engine Service Data

Valve Timing.....	5
Compression Pressure.....	5
Cylinder Head Flatness.....	5
Valve Data.....	5
Valve Spring.....	5
Valve Guide.....	5
Valve Seat.....	6
Camshaft and Camshaft Bearing.....	6
Cylinder Block.....	6
Piston.....	7
Piston Rings.....	7
Piston Pin.....	8
Crankshaft.....	8
Bearing Clearance.....	8
Available Main Bearings.....	8
Main Bearing Undersize.....	9
Connecting Rod Bearing Undersize.....	9
Flyweight Runout.....	9
Engine Lubrication System.....	9
Tightening Torques of Standard	
Metric Bolts.....	10
Tightening Torque of Standard	
Non-Metric Bolts.....	11
Tightening Torques for Engine Bolts.....	12

PART 8

**SPECIFICATIONS
AND CHARTS**

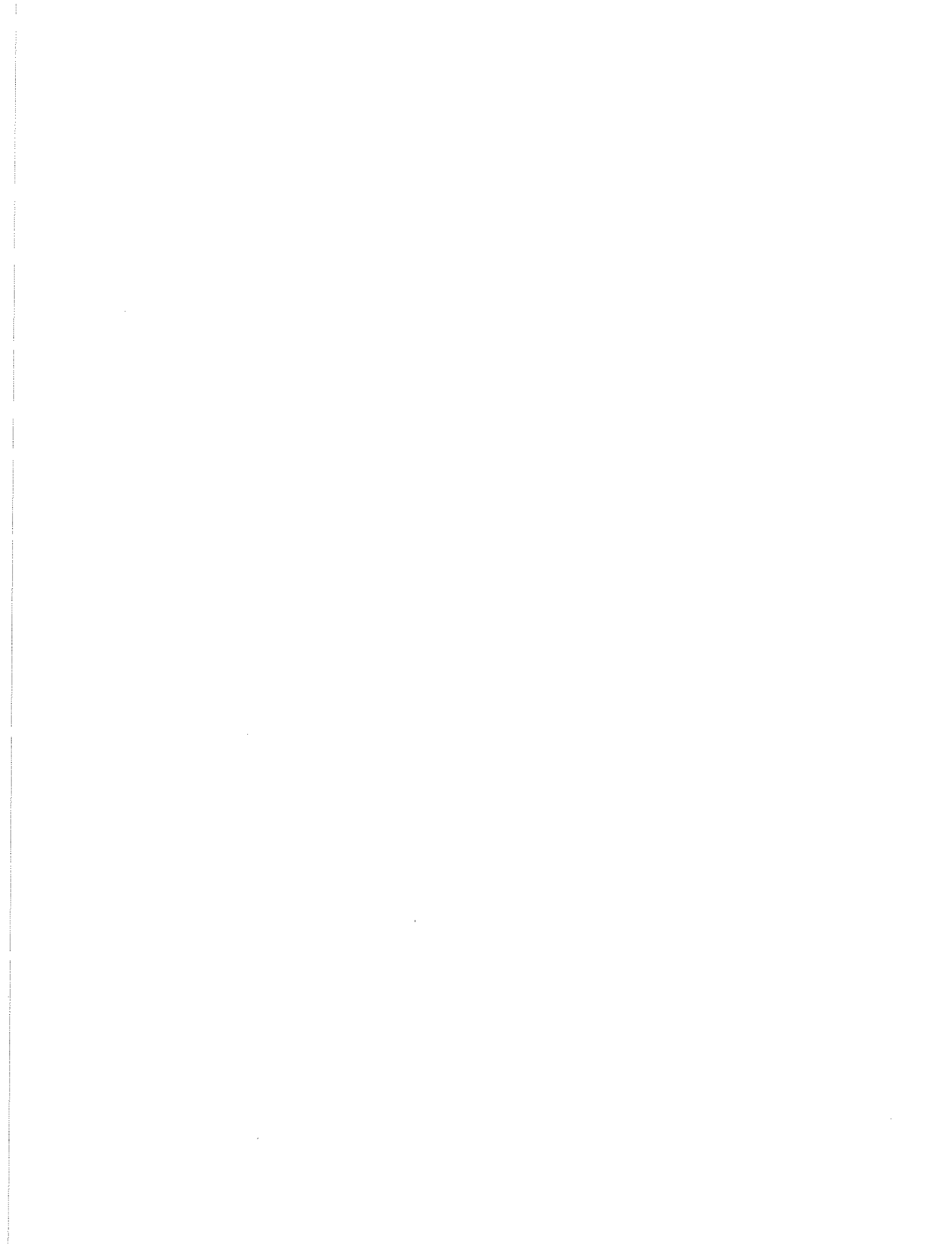

MARINE GENERATOR SPECIFICATIONS

Model QS-4.0G (At 120/240 Volts, 60 Hz)

Type of Equipment	Revolving Field a-c Generator
Rated Maximum Continuous a-c Power Output	4000 watts (4.0 kW)
Rated Volts	120 and/or 240 volts a-c
Rated Maximum Continuous Load Current	
At 120 volts a-c	33.3 a-c amperes
At 240 volts a-c	16.7 a-c amperes
Rated a-c Frequency	60 Hz at 1800 rpm
Phase	Single Phase
Power Factor	1.0
Number of Revolving Field (Rotor) Poles	4
Driven Speed of Revolving Field	1860 rpm at No-Load*
Stator Excitation Winding Resistance (plus or minus 10%)	1.65 ohms
Stator a-c Power Windings Resistance (plus or minus 10%)	
Wires 11 to 22	0.43 ohms
Wires 33 to 44	0.43 ohms
Rotor Winding Resistance (plus or minus 10%)	6.6 ohms

* Rated voltage and frequency are obtained at 1800 rpm. The slightly higher "no-load" rpm setting helps prevent excessive rpm, voltage and frequency droop under heavy electrical loading.

Model QS-4.0G (At 110/220 Volts, 50 Hz)

Type of Equipment	Revolving Field a-c Generator
Rated Maximum Continuous a-c Power Output	3300 watts (3.3 kW)
Rated Volts	110 and/or 220 volts a-c
Rated Maximum Continuous Load Current	
At 110 volts a-c	30 a-c amperes
At 220 volts a-c	15 a-c amperes
Rated a-c Frequency	50 Hz at 1500 rpm
Phase	Single Phase
Power Factor	1.0
Number of Revolving Field Poles	4
Driven Speed of Revolving Field	1550 rpm at No-Load*
Stator Excitation Winding Resistance (Plus or minus 10%)	1.65 ohms
Stator Power Windings Resistance (plus or minus 10%)	
Wires 11 to 22	0.43 ohms
Wires 33 to 44	0.43 ohms
Rotor Winding Resistance (plus or minus 10%)	6.5 ohms

* Rated voltage and frequency are obtained at 1500 rpm. The slightly higher "no-load" speed helps prevent excessive rpm, voltage and frequency droop under heavy electrical loading.

MARINE GENERATOR SPECIFICATIONS (Continued)

Model QS-6.5G (At 120/240 Volts, 60 Hz)

Type of Equipment	Revolving Field a-c Generator
Rated Maximum Continuous a-c Power Output	6500 watts (6.5 kW)
Rated Volts	120 and/or 240 volts a-c
Rated Maximum Continuous Load Current	
At 120 volts	54.2 a-c amperes
At 240 volts	27.1 a-c amperes
Rated a-c Frequency	60 Hz at 1800 rpm
Phase	Single Phase
Power Factor	1.0
Number of Revolving Field Poles	4
Driven Speed of Revolving Field	1860 rpm at No-Load*
Stator Excitation Winding Resistance (Plus or minus 10%)	1.30 ohms
Stator a-c Power Windings Resistance (Plus or minus 10%)	
Across Leads 11 and 22	0.26 ohms
Across Leads 33 and 44	0.26 ohms
Rotor Winding Resistance (Plus or minus 10%)	7.4 ohms

* Rated a-c voltage and frequency are obtained at 1800 rpm. The slightly high "no-load" setting helps prevent excessive rpm, frequency and voltage droop under heavy electrical loading.

Model QS-6.5G (At 110/220 Volts, 50 Hz)

Type of Equipment	Revolving Field a-c Generator
Rated Maximum Continuous a-c Power Output	5200 watts (5.2 kW)
Rated Volts	110 and/or 220 volts a-c
Rated Maximum Continuous Load Current	
At 110 volts	47.3 a-c amperes
At 220 volts	23.6 a-c amperes
Rated a-c Frequency	50 Hz at 1500 rpm
Phase	Single Phase
Power Factor	1.0
Number of Revolving Field Poles	4
Driven Speed of Revolving Field	1550 rpm at no-load
Stator Excitation Windings Resistance (plus or minus 10%)	1.30 ohms
Stator a-c Power Windings Resistance (Plus or minus 10%)	
Across Leads 11 and 22	0.26 ohms
Across Leads 33 and 44	0.26 ohms
Rotor Winding Resistance (Plus or minus 10%)	7.4 ohms

* Rated a-c voltage and frequency are obtained at 1500 rpm. The slightly high "no-load" setting helps prevent excessive rpm, frequency and voltage droop under heavy electrical loading.

MARINE GENERATOR SPECIFICATIONS (Continued)

Model QS-8.0G (At 120/240 Volts, 60 Hz)

Type of Equipment	Revolving Field a-c Generator
Rated Maximum Continuous a-c Power Output	8000 watts (8.0 kW)
Rated Volts	120 and/or 240 volts a-c
Rated Maximum Continuous Load Current	
At 120 volts	66.7 a-c amperes
At 240 volts	33.3 a-c amperes
Phase	Single Phase
Power Factor	1.0
Number of Revolving Field Poles	4
Driven Speed of Revolving Field	1860 rpm at No-Load*
Stator Excitation Winding Resistance (plus or minus 10%)	0.88 ohm
Stator a-c Power Winding Resistance (plus or minus 10%)	
Across Leads 11 and 22	0.16 ohm
Across Leads 33 and 44	0.16 ohm
Rotor Winding Resistance (plus or minus 10%)	7.4 ohms

* Rated voltage and frequency are obtained at 1800 rpm. The slightly high "no-load" speed setting helps prevent excessive rpm, frequency and voltage droop under heavy electrical loading.

Model QS-8.0G (at 110/220 Volts, 50 Hz)

Type of Equipment	Revolving Field a-c Generator
Rated Maximum Continuous a-c Power Output	6400 watts (6.4 kW)
Rated Volts	110 and/or 220 volts a-c
Rated Maximum Continuous Load Current	
At 110 volts	58.2 a-c amperes
At 220 volts	29.1 a-c amperes
Phase	Single Phase
Power Factor	1.0
Number of Revolving Field Poles	4
Driven Speed of Revolving Field	1550 rpm at No-Load*
Stator Excitation Winding Resistance (plus or minus 10%)	0.88 ohm
Stator a-c Power Windings Resistance (plus or minus 10%)	
Across Leads 11 and 22	0.16 ohm
Across Leads 33 and 44	0.16 ohm
Rotor Winding Resistance (plus or minus 10%)	7.4 ohms

* Rated voltage and frequency are obtained at 1500 rpm. The slightly high "no-load" speed setting helps prevent excessive rpm, frequency and voltage droop under heavy electrical loading.

GENERAL ENGINE SPECIFICATIONS

Engine Displacement	60 cu. in. (988cc)
No. of Cylinders	4, In-Line
Bore and Stroke	2.68 x 2.68 inches (68 x 68mm)
Valve Arrangement.....	Overhead Cam
Firing Order	1-3-4-2
Compression Ratio.....	9.5 to 1
Type of Engine Speed Governor.....	Fixed Speed, Mechanical Flyweight
Governed Speed Setting	
Units Rated 120/240 volts, 60 Hz.....	1860 rpm at No-Load
Units Rated 110/220 volts, 50 Hz.....	1550 rpm at No-Load

Engine Cooling System

Type	Heat Exchanger
Captive Water System Coolant Capacity	2.3 U.S. quarts
Recommended Coolant.....	50-50 mixture of low silicate ethylene glycol base anti-freeze and soft water

Ignition System

Timing.....	21° BTDC at 62 Hz (No-Load)
Distributor Point Gap.....	0.018-0.022 inch (0.45-0.55mm)
Dwell Angle	49°-55°
Condensor Capacity.....	0.20-0.24 micro-farad
Recommended Spark Plugs	
Champion.....	RN9YC
AC	R42XLS
NGK.....	BPR6ES
Spark Plug Gap.....	0.031-0.035 inch (0.8-0.9mm)

Lubrication System

Oil Pressure.....	25-50 psi (1.5-4.0 kg/cm ²)
Crankcase Oil Capacity (with Filter change)	3.0 U.S. quarts (2.8 liters)

ENGINE SERVICE DATA

Compression Pressure (at 350 rpm)

Standard	192 psi (13.5 kg/cm ²)
Minimum	164 psi (11.5 kg/cm ²)
Difference Limit	
Between Cylinders	14.0 psi (1.0 kg/cm ²)

Cylinder Head Flatness

Standard	Less than 0.0020 inch (0.05mm)
Limit	0.004 inch (0.1mm)

Valve Data

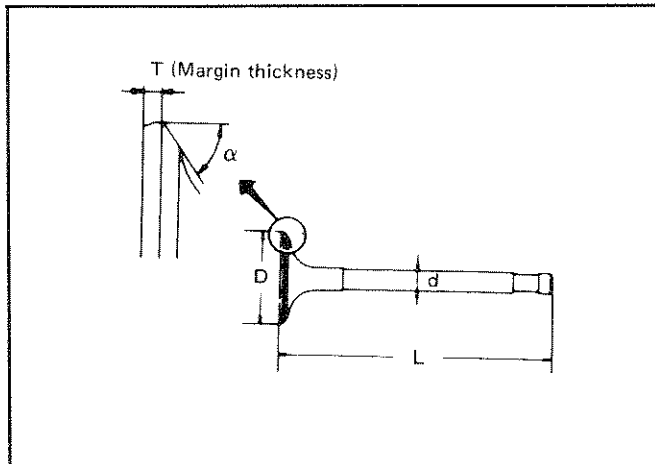

Valve Head Diameter "D"

Intake.....	1.358 inch (34.5mm)
Exhaust	1.18 inch (30mm)

Valve Length "L"

Intake.....	4.2736-4.2854 inch (108.55-108.85mm)
Exhaust	4.2539-4.2657 inch (108.05-108.35mm)

Valve Stem Diameter "d"

Intake.....	0.2744-0.2750 inch (6.970-6.985mm)
Exhaust	0.2734-0.2740 inch (6.945-6.960mm)

Valve Seat Angle "α"

Intake & Exhaust	45°15' - 45°45'
------------------------	-----------------

Valve Margin "T" Limit.....

0.020 inch (0.5mm)

Valve Stem End Surface

Grinding Limit

0.008 inch (0.2mm)

Valve Clearance (Hot)

Intake.....	0.0098 inch (0.25mm)
Exhaust	0.0118 inch (0.30mm)

Valve Clearance (Cold)

Intake.....	0.009 inch (0.22mm)
Exhaust	0.009 inch (0.22mm)

Valve Spring

Free Height.....	1.8386 inch (46.70mm)
Pressure Height.....	1.122 in. at 122.6 lbs (28.5mm at 55.6kg)
Assembled Height	1.457 in. at 36.4 lbs (37.0mm at 16.5 kg)
Out of Square "S"	0.079 inch (2.0mm)

Valve Guide

Standard OD	0.4340-0.4344 inch (11.023-11.034mm)
Service Limit OD	0.4418-0.4423 inch (11.223-11.234mm)
Valve Guide ID	0.2758-0.2764 inch (7.005-7.020mm)

Valve Guide (Continued)

Cylinder Head Valve Guide Hole Diameter

Standard	0.4315-0.4322 inch (10.960-10.978mm)
Service Limit	0.4394-0.4401 inch (11.160-11.178mm)

Interference Fit of

Valve Guide	0.0018-0.0029 inch (0.045-0.074mm)
-------------------	---------------------------------------

Valve Stem to Valve Guide Clearance

Intake (Standard)	0.0006-0.0018 inch (0.015-0.045mm)
Exhaust (Standard)	0.0018-0.0030 inch (0.045-0.075mm)
Maximum Tolerance	0.004 inch (0.1mm)

Valve Deflection Limit	0.008 inch (0.2mm)
------------------------------	--------------------

Valve Seat

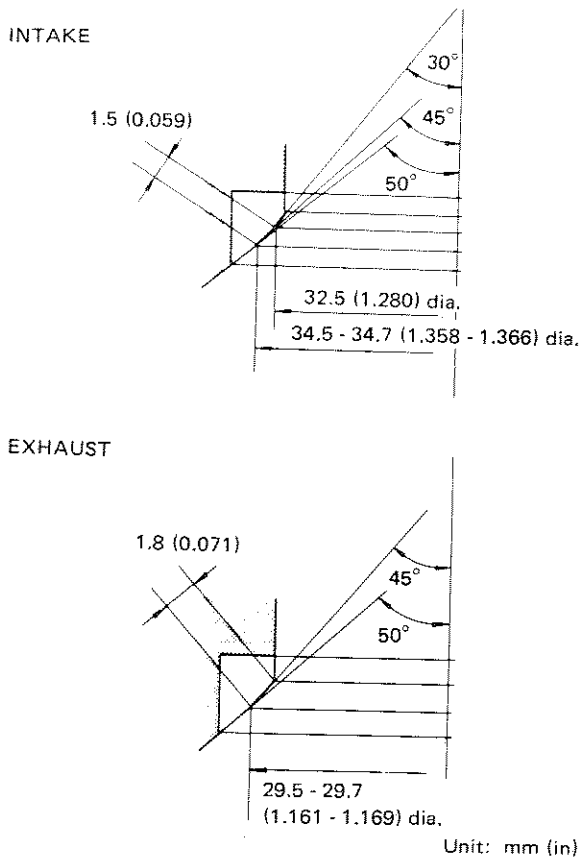

Camshaft and Camshaft Bearing

Camshaft Journal to Bearing Clearance

Standard	0.0012-0.0028 inch (0.03-0.07mm)
Maximum Tolerance	0.0059 inch (0.15mm)

Camshaft Bearing ID	1.5748-1.5760 inch (40.00-40.03mm)
---------------------------	---------------------------------------

Camshaft Journal OD	1.5728-1.5736 inch (39.95-39.97mm)
---------------------------	---------------------------------------

Camshaft Bend (Total Indicated Reading)

Standard	Less than 0.0008 inch (0.02mm)
----------------	-----------------------------------

Max. Tolerance	0.004 inch (0.1mm)
----------------------	--------------------

Camshaft End Play	0.0012-0.0122 inch (0.03-0.31mm)
-------------------------	-------------------------------------

Cam Height "A"

Intake	1.3295-1.3394 inch (33.77-34.02mm)
Exhaust	1.3280-1.3378 inch (33.73-33.98mm)

Wear Limit of Cam Height	0.008 inch (0.2mm)
--------------------------------	--------------------

Cylinder Block

Surface Flatness

Standard	Less than 0.020 inch (0.05mm)
----------------	----------------------------------

Limit	0.0039 inch (0.10mm)
-------------	----------------------

Cylinder Block (Continued)

Cylinder Bore Inner Diameter

Standard 2.6772-2.6783 inch
(68.00-68.03mm)

Wear Limit 0.0039 inch (0.10mm)

Cylinder Bore Out-of-Round

X - Y Less than 0.0008 inch
(0.02mm)

Cylinder Bore Taper

A - B Less than 0.0008 inch
(0.02mm)

Difference in ID Between Cylinders

Standard Less than 0.0020 inch
(0.05mm)

Wear Limit 0.0079 inch (0.20mm)

Main Journal ID

Grade No. 0 1.9291-1.9293 inch
(49.000-49.004mm)

Grade No. 1 1.9293-1.9294 inch
(49.004-49.008mm)

Grade No. 2 1.9294-1.9296 inch
(49.008-49.012mm)

Grade No. 3 1.9296-1.9298 inch
(49.012-49.016mm)

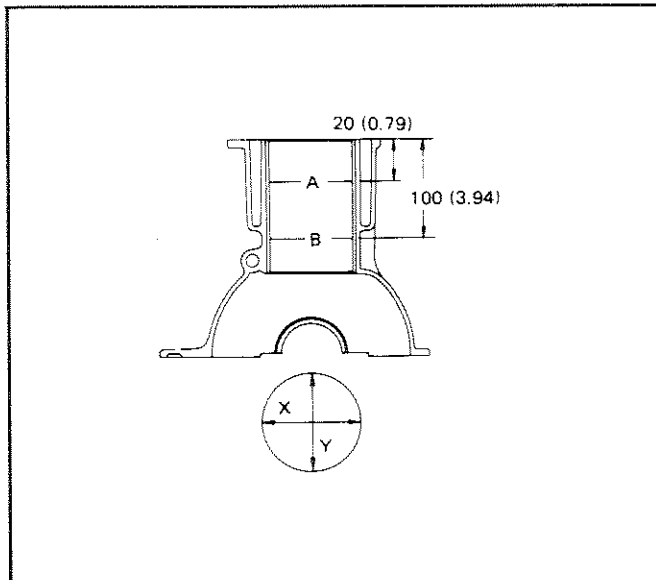

Piston

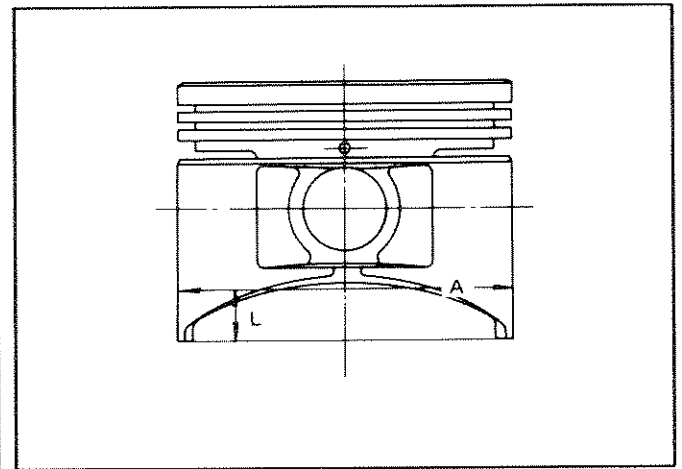

Piston Skirt Diameter "A"

Standard 2.6759-2.6770 inch
(67.967-67.997mm)

"L" Dimension 0.35 inch (9mm)

Piston Pin Hole Diameter 0.6694-0.6698 inch
(17.003-17.012mm)

Piston Clearance

to Cylinder Block 0.0009-0.0017 inch
(0.023-0.043mm)

Piston Rings

Side Clearance (Standard)

Top 0.0016-0.0029 inch
(0.040-0.073mm)

2nd 0.0012-0.0025 inch
(0.030-0.063mm)

Oil 0.0069 inch (0.175mm)

Side Clearance Limit (All) 0.008 inch (0.2mm)

Piston Ring Gap (Standard)

Top (No. 1 Grade) 0.0083-0.0118 inch
(0.21-0.30mm)

Top (No. 2 & 3 Grade) 0.0071-0.0118 inch
(0.18-0.30mm)

2nd 0.0059-0.0154 inch
(0.15-0.39mm)

Oil Ring 0.0079-0.0311 inch
(0.20-0.79mm)

Piston Ring Gap Limit (All) 0.031 inch (0.8mm)

Piston Pin

Outer Diameter	0.6663-0.6678 inch (16.924-16.961mm)
Pin to Piston Clearance	0.0003-0.0005 inch (0.008-0.012mm)
Interference Fit of Piston Pin to Connecting Rod	0.0007-0.0015 inch (0.017-0.038mm)

Connecting Rod

Center Distance	4.5079 inch (114.5mm)
Bend Limit per 3.94 inch (100mm)	
Limit	0.0020 inch (0.05mm)
Piston Pin Bore Diameter	0.6678-0.6684 inch (16.962-16.978mm)
Big End Play	
Standard	0.0039-0.0146 inch (0.10-0.37mm)
Limit	0.020 inch (0.5mm)

Crankshaft

Main Journal Diameter	
Grade No. 0	1.7703-1.7705 inch (44.966-44.970mm)
Grade No. 1	1.7702-1.7703 inch (44.962-44.966mm)
Grade No. 2	1.7700-1.7702 inch (44.958-44.962mm)
Grade No. 3	1.7698-1.7700 inch (44.954-44.958mm)
Pin Journal Diameter "Dp"	1.5732-1.5736 inch (39.96-39.97mm)
Center Distance "r"	1.339 inch (34.0mm)
Out-of-Round	
X - Y	Less than 0.004 inch (0.0mm)
Taper	
A - B	0.0008 inch (0.02mm)
Bend (Total Indicator Reading) ..	Less than 0.0031 inch (0.08mm)
Free End Play (Standard)	0.0024-0.0087 inch (0.06-0.22mm)
Free End Play (Limit)	0.0197 inch (0.50mm)

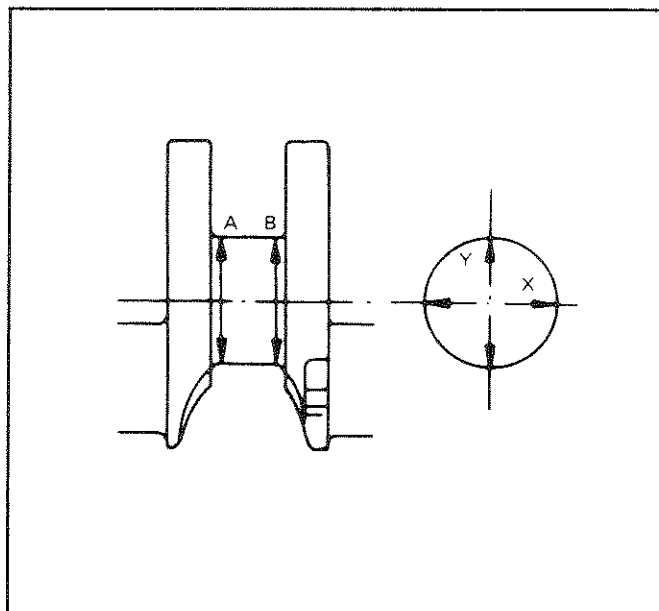

Bearing Clearance

Main Bearing Clearance	
Standard	0.0012-0.0020 inch (0.03-0.05mm)
Limit	0.0030 inch (0.075mm)
Connecting Rod Bearing Clearance	
Standard	0.0008-0.0024 inch (0.02-0.06mm)
Limit	0.0047 inch (0.12mm)

Available Main Bearings (with or without Oil Groove)

Grade No. 0	
Thickness	0.0787-0.0789 inch (2.000-2.004mm)
Identification Color	Black
Grade No. 1	
Thickness	0.0788-0.0790 inch (2.002-2.006mm)
Identification Color	Brown
Grade No. 2	
Thickness	0.0789-0.0791 inch (2.004-2.008mm)
Identification Color	Green
Grade No. 3	
Thickness	0.0790-0.0791 inch (2.006-2.010mm)
Identification Color	Yellow

Available Main Bearings (with or without Oil Groove) - (Continued)

Grade No. 4

Thickness..... 0.0791-0.0792 inch
(2.008-2.012mm)

Identification Color..... Blue

Grade No. 5

Thickness..... 0.0791-0.0793 inch
(2.010-2.014mm)

Identification Color..... Pink

Grade No. 6

Thickness..... 0.0792-0.0794 inch
(2.012-2.016mm)

Identification Color..... Red

Main Bearing Undersize

Crank Journal Diameter "Dm"

Standard 1.7697-1.7705 inch
(44.95- 44.97mm)

Undersize

0.0098 inch (0.25mm) 1.7598-1.7606 inch
(44.70-44.72mm)

Connecting Rod Bearing Undersize

Crank Main Journal Diameter "Dp"

Standard 1.5732-1.5736 inch
(39.96-39.97mm)

Undersize

0.0098 inch (0.25mm) 1.5634-1.5638 inch
(39.71-39.72mm)

Flyweight Runout (Total Indicator Reading)

Less than 0.0059 inch (0.15mm)

Engine Lubrication System

Oil Pressure

At 1200 rpm.....28psi (2 kg/cm²)

At 2000 rpm.....43psi (3 kg/cm²)

Oil Pump Clearances

Rotor Tip.....less than 0.008 inch
(0.2mm)

Engine Lubrication System (Continued)

Outer Oil Pump Rotor

to Body Clearance.....Less than 0.008 inch
(0.2mm)

Oil Pump Rotor

to Straightedge Clearance.....Less than 0.008 inch
(0.2mm)

TIGHTENING TORQUES OF STANDARD METRIC BOLTS

Grade	Bolt or nut size	Bolt or nut diameter* mm	Pitch mm	Tightening torque		
				N·m	kg·m	ft·lb
4T	M6	6.0	1.0	3 - 4	0.3 - 0.4	2.2 - 2.9
	M8	8.0	1.25	8 - 11	0.8 - 1.1	5.8 - 8.0
			1.0	8 - 11	0.8 - 1.1	5.8 - 8.0
	M10	10.0	1.5	16 - 22	1.6 - 2.2	12 - 16
			1.25	16 - 22	1.6 - 2.2	12 - 16
	M12	12.0	1.75	26 - 36	2.7 - 3.7	20 - 27
1.25			30 - 40	3.1 - 4.1	22 - 30	
M14	14.0	1.5	46 - 62	4.7 - 6.3	34 - 46	
7T	M6	6.0	1.0	6 - 7	0.6 - 0.7	4.3 - 5.1
	M8	8.0	1.25	14 - 18	1.4 - 1.8	10 - 13
			1.0	14 - 18	1.4 - 1.8	10 - 13
	M10	10.0	1.5	25 - 35	2.6 - 3.6	19 - 26
			1.25	26 - 36	2.7 - 3.7	20 - 27
	M12	12.0	1.75	45 - 61	4.6 - 6.2	33 - 45
1.25			50 - 68	5.1 - 6.9	37 - 50	
M14	14.0	1.5	76 - 103	7.7 - 10.5	56 - 76	
9T	M6	6.0	1.0	8 - 11	0.8 - 1.1	5.8 - 8.0
	M8	8.0	1.25	19 - 25	1.9 - 2.5	14 - 18
			1.0	20 - 27	2.0 - 2.8	14 - 20
	M10	10.0	1.5	36 - 50	3.7 - 5.1	27 - 37
			1.25	39 - 51	4.0 - 5.2	29 - 38
	M12	12.0	1.75	65 - 88	6.6 - 9.0	48 - 65
1.25			72 - 97	7.3 - 9.9	53 - 72	
M14	14.0	1.5	109 - 147	11.1 - 15.0	80 - 108	

1. Special parts are excluded.
2. This standard is applicable to bolts having the following marks embossed on the bolt head.

Grade	Mark
4T	4
7T	7
9T	9

*: Nominal diameter

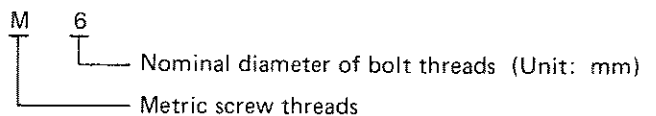

TIGHTENING TORQUES FOR ENGINE BOLTS

Intake and Exhaust Manifold Nuts.....	12-15 ft-lbs (16-21 N-m)
Spark Plug.....	18-22 ft-lbs (25-29 N-m)
Water Pump Bolt.....	2.9-3.6 ft-lbs (4-5 N-m)
Crankshaft Pulley Bolt.....	61-69 ft-lbs (83-93 N-m)
Thermostat Housing Bolt.....	2.0-3.6 ft-lbs (4-5 N-m)
Oil Pressure Switch.....	9.0-12.7 ft-lbs (12.3-17.2 N-m)
Camshaft Pulley Bolt.....	6.5-8.7 ft-lbs (9-12 N-m)
Connecting Rod Nut.....	22-25 ft-lbs (29-34 N-m)
Cylinder Head Bolts.....	See Paragraph 2.3.12
Cylinder Head Front Cover.....	2.9-3.6 ft-lbs (4-5 N-m)
Flywheel Bolts.....	43-51 ft-lbs (59-69 N-m)
Drive Plate Bolt.....	51-58 ft-lbs (69-78 N-m)
Main Bearing Cap Bolt*.....	34-38 ft-lbs (46-52 N-m)
Oil Pan Bolt.....	2.9-3.6 ft-lbs (4-5 N-m)
Oil Pan Drain Plug.....	26-35 ft-lbs (35-47 N-m)
Rocker Shaft Bolt.....	13-15 ft-lbs (18-21 N-m)
Tensioner Lock Nut.....	11-12 ft-lbs (15-17 N-m)
Rocker Cover Nut.....	2.2-3.6 ft-lbs (3-5 N-m)
Rocker Arm Lock Nut.....	8-11 ft-lbs (11-15 N-m)
Oil Pump Idler Gear Bolt.....	4.3-5.1 ft-lbs (6-7 N-m)
Oil Pump Securing Bolt.....	12-16 ft-lbs (16-22 N-m)
Water Pump Securing Bolt.....	2.9-3.6 ft-lbs (4-5 N-m)
Water Outlet Securing Bolt.....	3.6-5.8 ft-lbs (5-8 N-m)

* Tighten or loosen in 2 or 3 stages

