

P/N A1368

**GENERAC**  
One-Stop Service

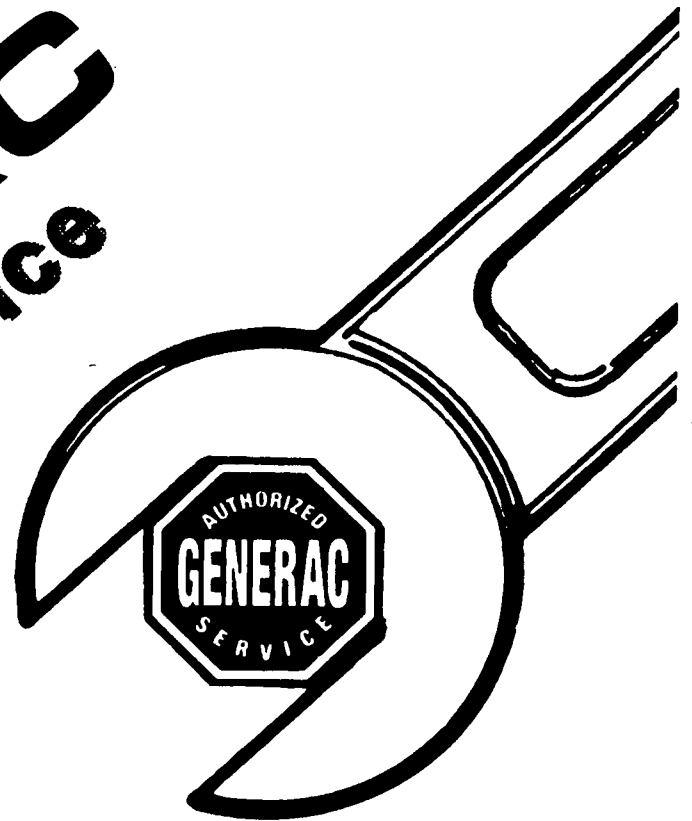

**1.6**

**GAS**

**REPAIR  
MANUAL**

P.O. BOX 8 WAUKESHA WI. 53187

PHONE: (414) 544-4811 / FAX: (414) 544-0179

PRINTED IN U.S.A.

ISSUED: 09/30/96

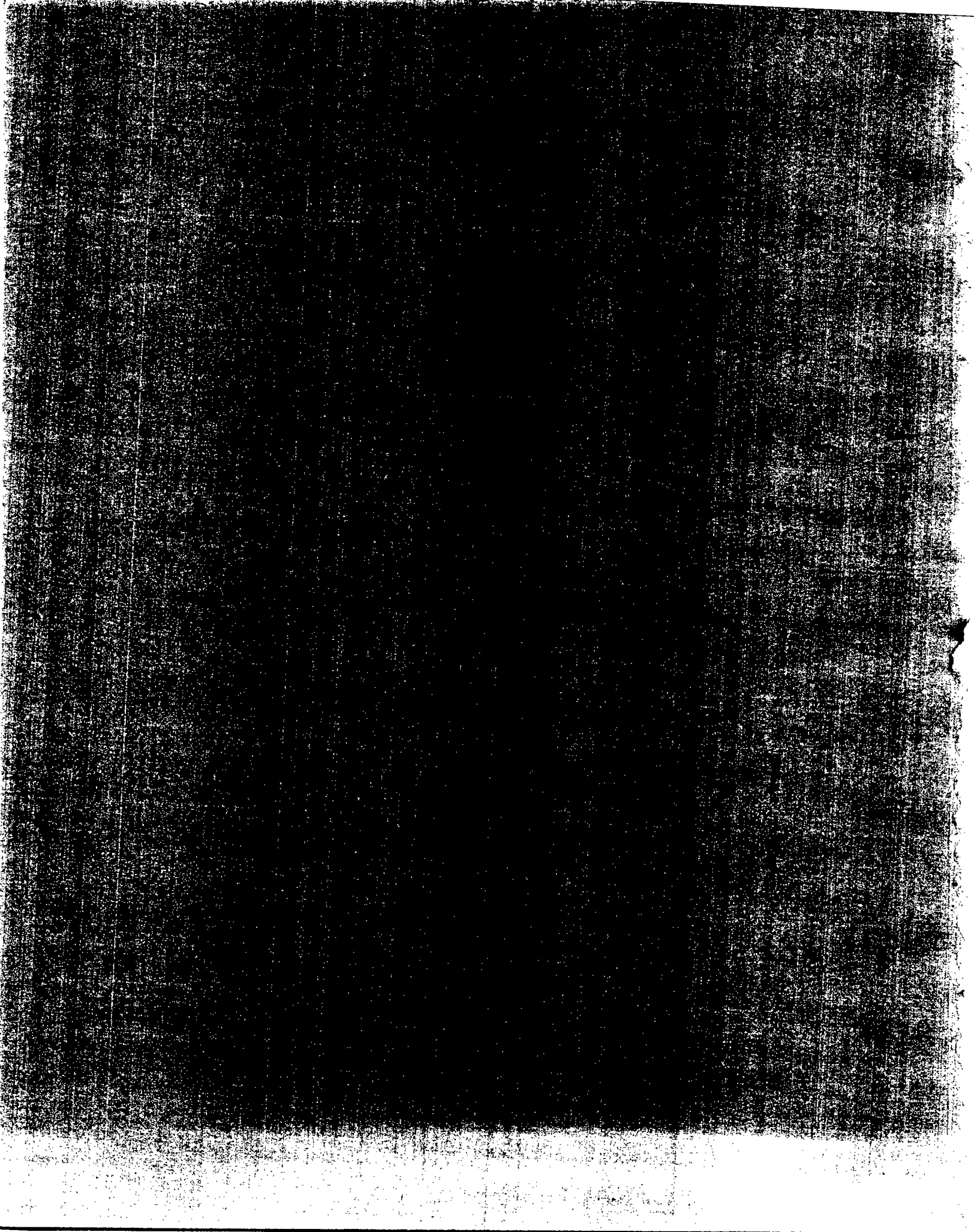

# TABLE OF CONTENTS

<b>ENGINE DISASSEMBLY</b>	<b>PAGE 2-3</b>
<b>CYLINDER BLOCK INSPECTION / REPAIR</b>	<b>PAGE 4-8</b>
<b>CRANKSHAFT AND RELATED COMPONENTS</b>	<b>PAGE 9-29</b>
<b>CYLINDER HEAD INSPECTION / REPAIR</b>	<b>PAGE 30-44</b>
<b>VALVE TIMING</b>	<b>PAGE 45-49</b>
<b>ENGINE REASSEMBLY</b>	<b>PAGE 50-56</b>
<b><u>TECHNICAL DATA</u></b>	
<b>Main bearing supports, auxiliary shaft, cyl. bore and piston clearances.</b>	<b>PAGE 57</b>
<b>Crankshaft bearings, crank pins, thrust washers, and crankshaft end-play.</b>	<b>PAGE 58</b>
<b>Cylinder bore and wrist pins, rings, ring grooves and ring gap.</b>	<b>PAGE 59</b>
<b>Connecting rod and crankshaft main journals.</b>	<b>PAGE 60</b>
<b>Valve and valve guide data.</b>	<b>PAGE 61</b>
<b>Valve springs, camshaft bearings, camshaft lift and bearings in housing.</b>	<b>PAGE 62</b>
<b>Tappet housing, tappets, and shims.</b>	<b>PAGE 63</b>
<b>Timing angles, and auxiliary shaft bearings.</b>	<b>PAGE 64</b>
<b>Cooling and oil pump data.</b>	<b>PAGE 65</b>
<b>Miscellaneous torque specifications.</b>	<b>PAGE 66</b>
<b>Master G.E.N. Express Network listings</b>	<b>PAGE 67</b>
<b>Certified Central Service Network listings</b>	<b>PAGE 68</b>

# ENGINE DISASSEMBLY

---

## **DISASSEMBLY:**

- \* Drain the engine oil.
- \* Place the engine on a suitable engine stand.
- \* Disassemble the engine in traditional fashion, labeling all parts (i.e.) bolts and numbered sequences etc. to assure proper re-assembly.
- \* The number stamped on the cylinder block / crankcase and on the main bearing caps should be the same and legible from the flywheel side. The position of each cap is given by a set of progressive marks which begin at the timing side.

***NOTE:*** *When the engine has been disassembled, the components should be carefully cleaned and checked.. The pages which follow in this manual contain instructions for the main checks and measuring operations necessary in determining whether or not the components should be reused and refitted. In addition they contain the correct refitting procedures to be used in order to reassemble the engine quickly and efficiently.*

# **ENGINE DISASSEMBLY**

**Disassemble the engine in the following order. Remember to inspect all parts for unusual wear or damage, and to CLEARLY LABEL all parts for easy reassembly.**

- 1. Remove the cylinder head camshaft rear cover plate and gasket.**
- 2. Remove the distributor and spark plug wires.**
- 3. Remove the front timing belt cover.**
- 4. Remove the fuel pump assembly.**
- 5. Remove the dipstick.**
- 6. Remove the breather assembly.**
- 7. Remove the v-belts.**
- 8. Remove the oil filter (Make sure oil is drained from engine).**
- 9. Remove thermostat cover and thermostat and gasket.**
- 10. Remove the carburetor assembly.**
- 11. Remove intake manifold and related items.**
- 12. Remove exhaust manifold heat shield, and manifold assembly.**
- 13. Remove alternator assembly.**
- 14. Remove timing gear pulley and timing belt.**
- 15. Remove timing belt tensioner.**
- 16. Remove crankshaft pulley**
- 17. Remove crankshaft gear.**
- 18. Remove the timing belt inner cover**
- 19. Remove the cylinder head and gasket.**
- 20. Remove the distributor drive gear from the cylinder block.**
- 21. Remove the distributor driveshaft .**
- 22. Remove the oil pan and gasket.**
- 23. Remove the flywheel.**
- 24. remove the oil pump assembly.**
- 25. Remove the Piston/Connecting rod assemblies and inspect the bearings. (Number the con-rods prior to removal)**
- 26. Remove the oil dipstick tube.**
- 27. Remove the rear main oil seal boss from the rear of the block.**
- 28. Remove the main bearing caps from the cylinder block and inspect bearings.. (Number caps prior to removal)**
- 29. Remove the crankshaft assembly and inspect all bearing surfaces.**
- 30. Remove camshaft from cylinder block.**

**NOTE: Reverse order for reassembly.**

# CYLINDER BLOCK INSPECTION / REPAIR

Figure 1.1

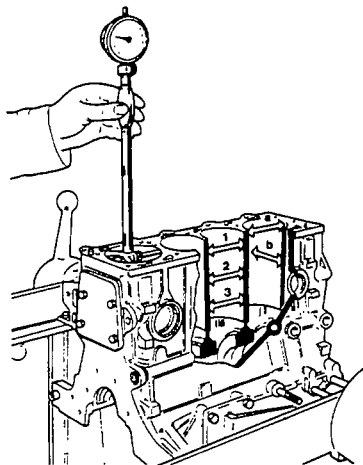

## CYLINDER BORES

### Checking and Measuring

Measure the maximum values for cylinder bore ovality, taper and wear. (See Figure 1.1)

Visually inspect all the sliding surfaces.

**NOTE:** In the case of re-boring, all the cylinder bores must be the same oversize.

The permissible tolerances for re-boring cylinder bores are: taper (difference between first and third measurement)  $\pm .002$  in; ovality (difference between a and b)  $\pm .002$  in.

Figure 1.2

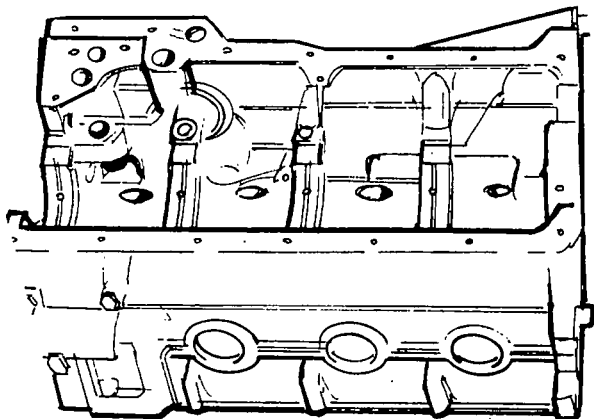

### Location of piston cooling jets

The cylinder block / crankcase has four (4) jets, directly supplied by the main bearings. These jets cool and lubricate the pistons and gudgeon (wrist) pins. (Figure 1.2)

Piston cooling jet

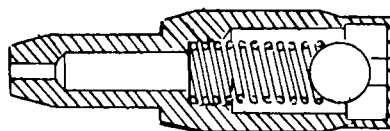

### Normal diameter cylinder bore selection

The arrows indicate the letters showing the grades to which each cylinder bore in a new engine belongs.

# CYLINDER BLOCK INSPECTION / REPAIR

Figure 1.3

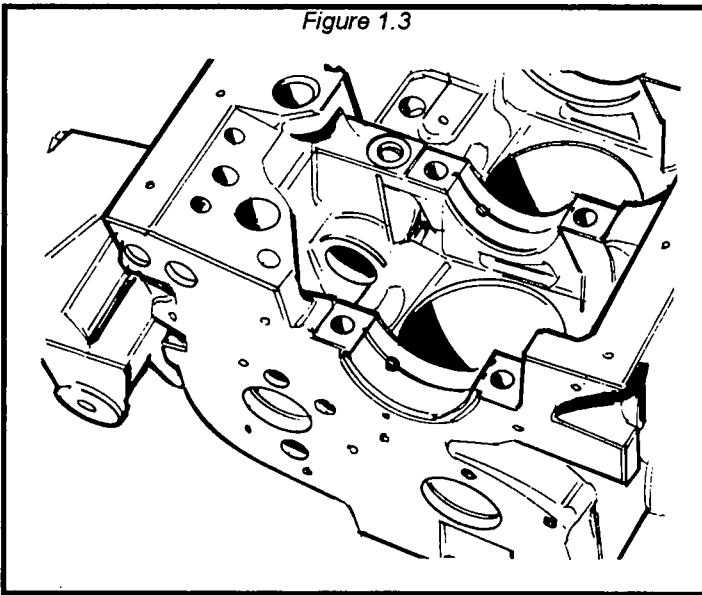

## Checking auxiliary shaft bush seats

**NOTE:** In the case of ovality or grooves on the internal surfaces the bushes (bearings) should be replaced. (See Figure 1.3)

The operations of removing-refitting and reaming auxiliary shaft bushes necessitate changing the position of the engine on the rotating stand. In order to raise the engine which is necessary to work correctly, the brackets should be adjusted until the position illustrated in the photos below is obtained. The engine should be returned to the original position when the operations are finished.

Figure 1.4

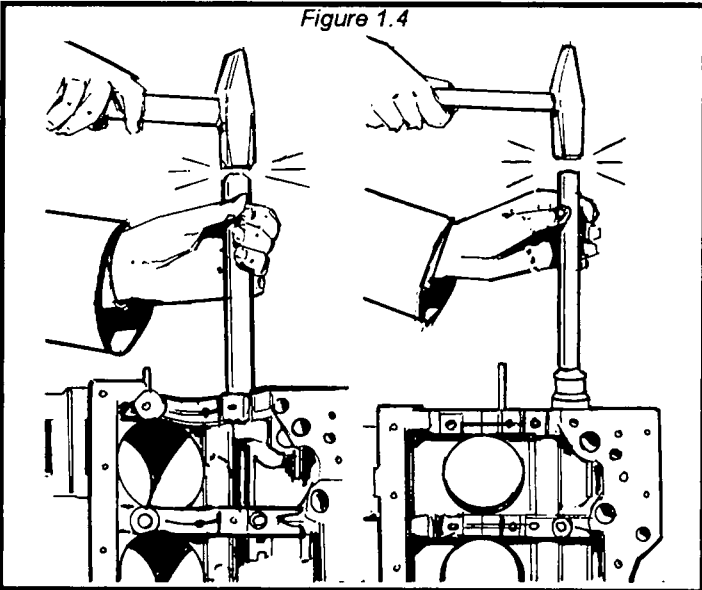

## Removing-refitting timing side bush (bearing)

When refitting the bush (bearing), turn it in such a way that the lubrication oil inlet opening is in line with the appropriate duct in the cylinder block / crankcase. The oil spline should be facing the timing side. (See Figure 1.4)

Figure 1.5

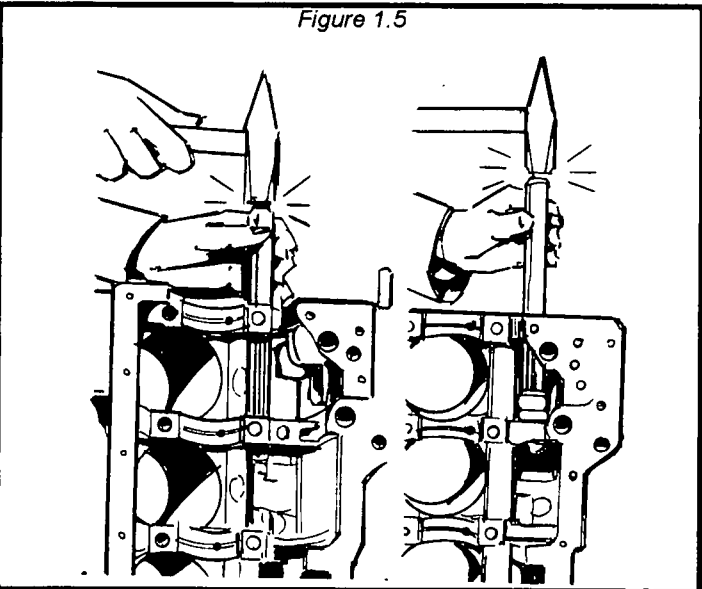

## Removing-refitting flywheel side bush

When refitting the flywheel side bush (Bearing), position it so that the lubrication opening is in line with the appropriate duct in the cylinder block / crankcase. the oil drain spline should be facing the flywheel side. (See Figure 1.5)

# CYLINDER BLOCK INSPECTION / REPAIR

Figure 1.6

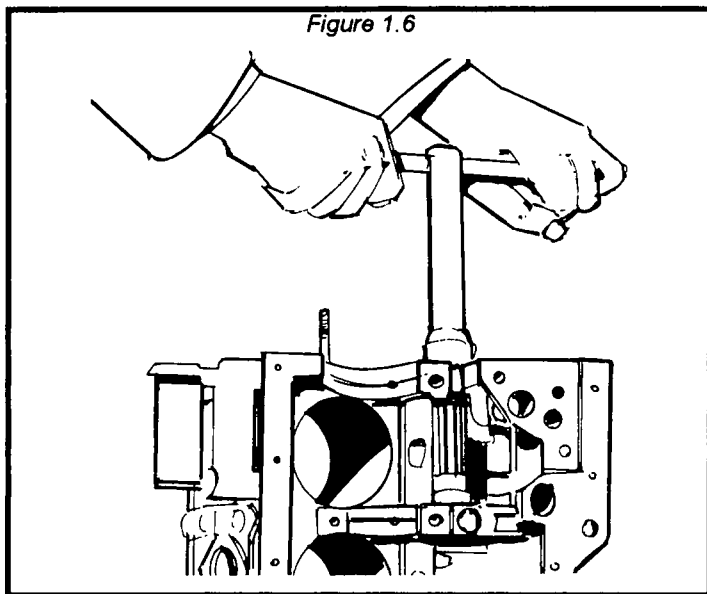

## Reaming timing side bush

**NOTE:** In order to ream the main shaft bushes (bearings), the engine mounting has to be removed from the cylinder block-crankcase, the bracket must be moved away from the cylinder block / crankcase. (See Figure 1.6) Refit the mounting when the reaming is complete.

Figure 1.7

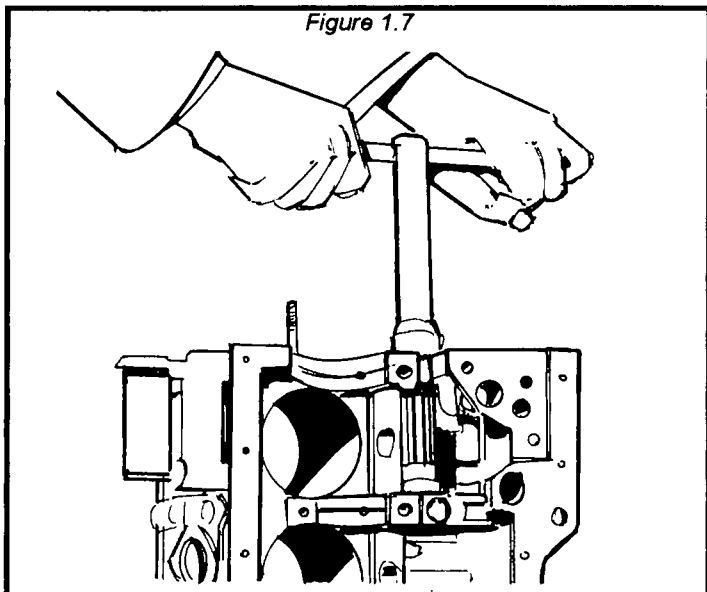

Reaming the flywheel side bush.  
(See Figure 1.7)

Figure 1.8

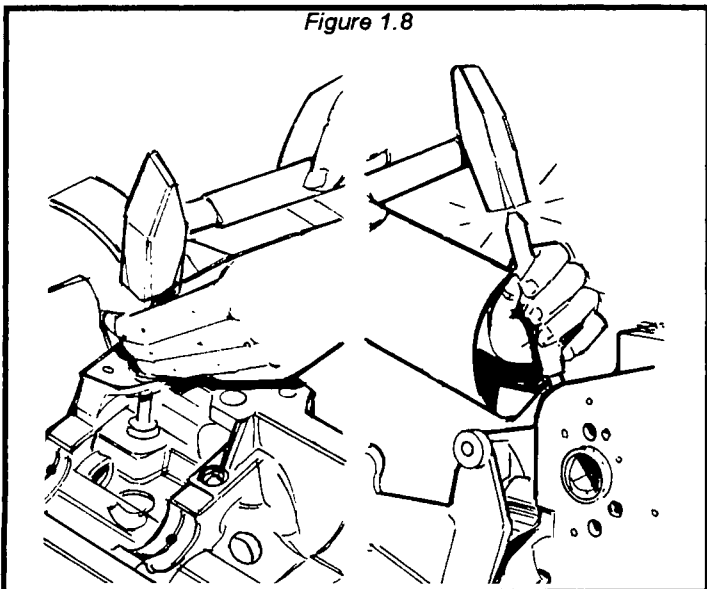

## Removing-refitting the oil pump drive gear bush. (bearing)

If the bush (bearing) has grooves or is excessively oval, it should be replaced.  
(See Figure 1.8)

# CYLINDER BLOCK INSPECTION / REPAIR

Figure 1.9

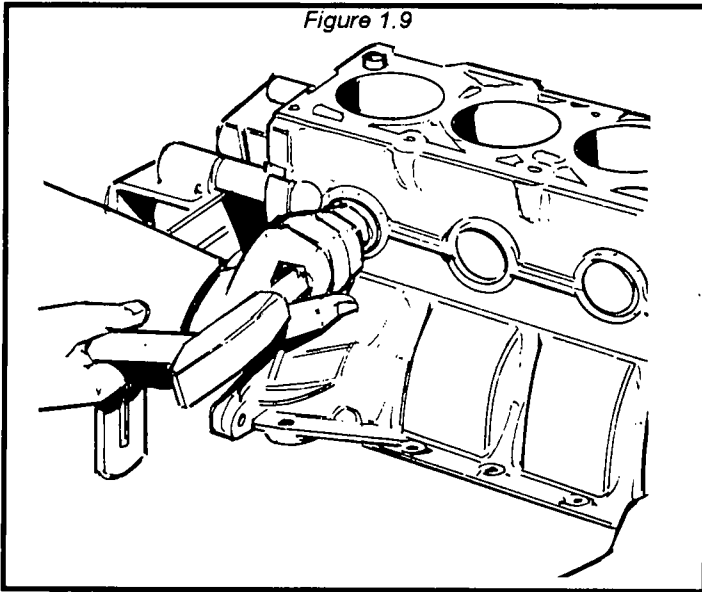

**Removing-refitting cylinder block / crankcase side sealing plugs.**

Before fitting the plugs, smear the cylinder block / crankcase contact surfaces with sealant.  
(See Figure 1.9)

Figure 1.10

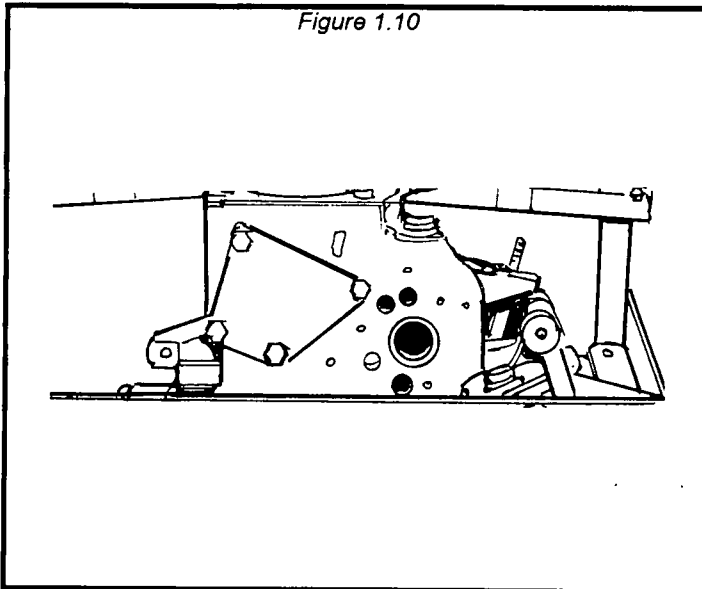

**Removing-refitting front and rear engine sealing plugs.**

Before fitting the plugs, smear some sealant on the surfaces in contact with the cylinder block / crankcase. (See Figure 1.10)

Figure 1.11

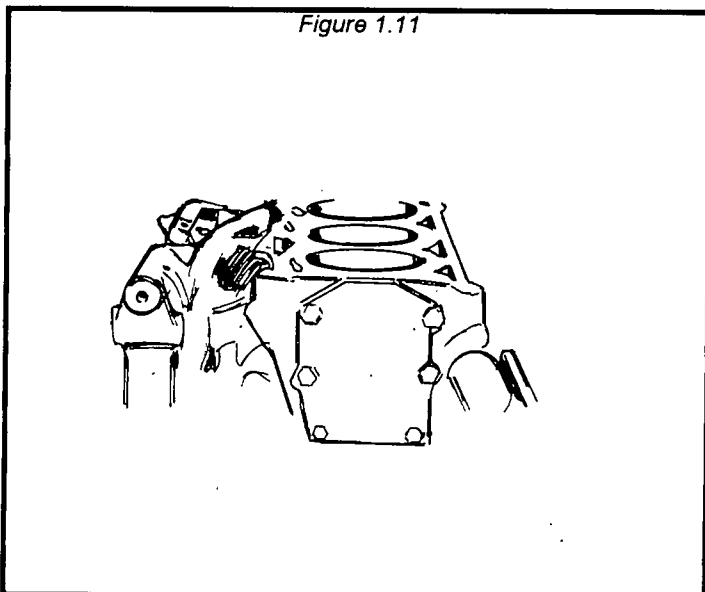

**Removing and refitting front and rear cylinder block / crankcase sealing plates.**  
(See Figure 1.11)

# CYLINDER BLOCK INSPECTION / REPAIR

Figure 1.12

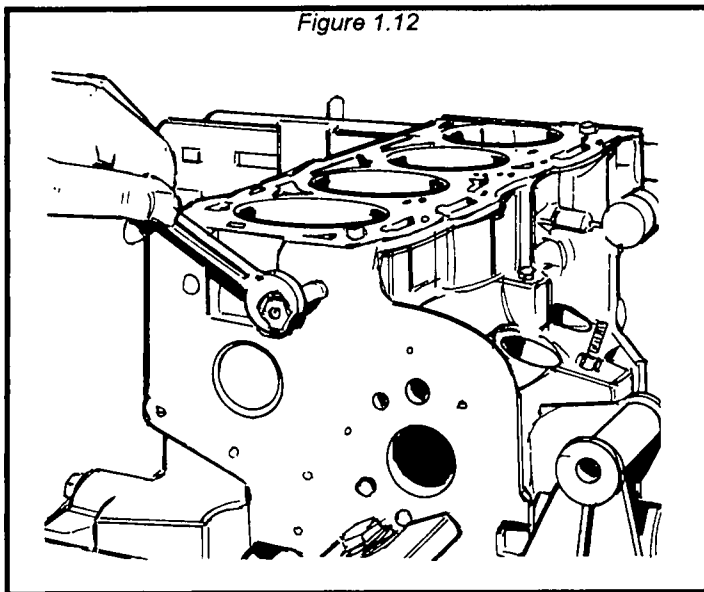

**Removing and refitting stud**  
(See Figure 1.12)

Figure 1.13

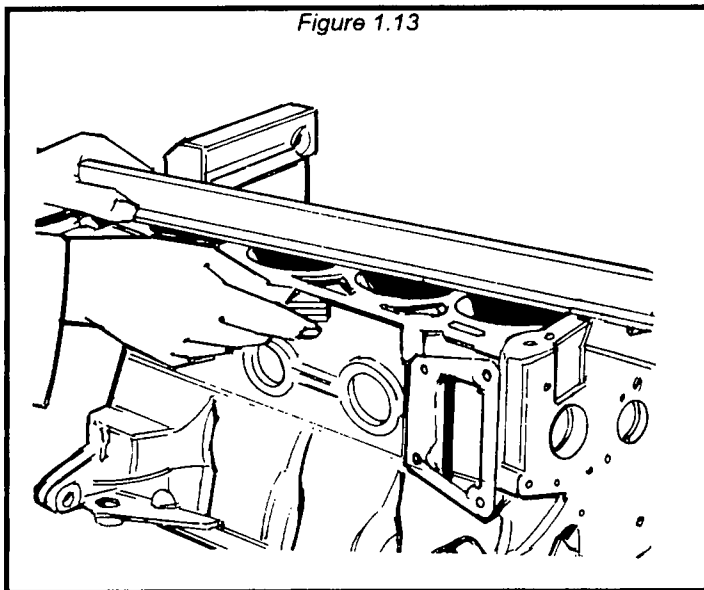

**Checking cylinder head support surface using straight edge feeler gauge.**  
(See Figure 1.13)

**NOTE:** The maximum deformation of the cylinder head support surface must not exceed .004 in.

# CRANKSHAFT AND RELATED COMPONENTS

Figure 2.1

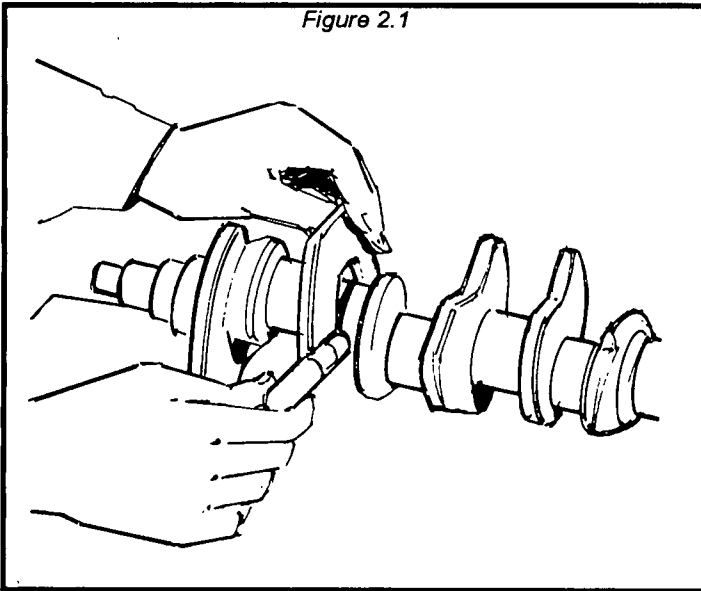

## CRANKSHAFT:

### Measuring main journals and crankpins

The undersize grades available are .01-.02 in. (See Figure 2.1)

**NOTE:** When grinding the crankshaft journals, the permissible tolerances are:

Ovality: + or - .002 in.

Taper: + or - .002 in.

Non alignment between main journals: + or - .0009 in.

Non alignment between crankpins: + or - .005 in.

Figure 2.2

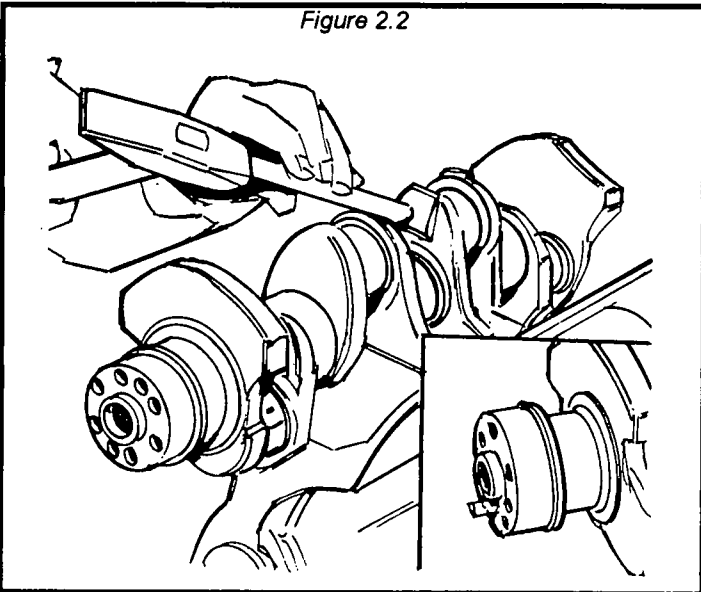

All the bearings are always ground to the same undersize grade so as not to alter the balance of the shaft. As a result, it is generally advisable to replace the crankshaft rather than grind the bearing surfaces. (See Figure 2.2)

### Removing and refitting oil duct plugs

**NOTE:** The 1.6 liter engine cranshaft is charaterized by the presense of a centering bush (shown by the arrow in the inset) on the flywheel attachment flange for the positioning the flywheel when refitting.

Figure 2.3

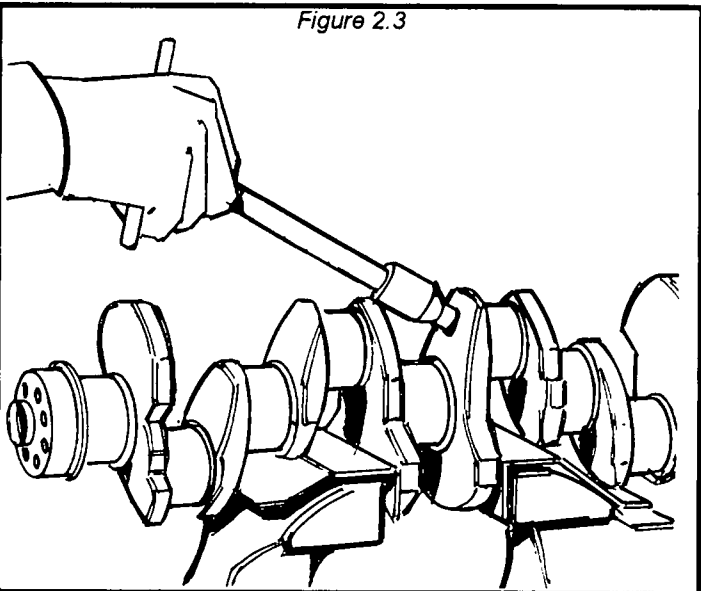

### Reaming oil duct plug seats

When grinding the bearings, the oil passages **MUST** be carefully washed. (See Figure 2.3)

# CRANKSHAFT AND RELATED COMPONENTS

Figure 2.4

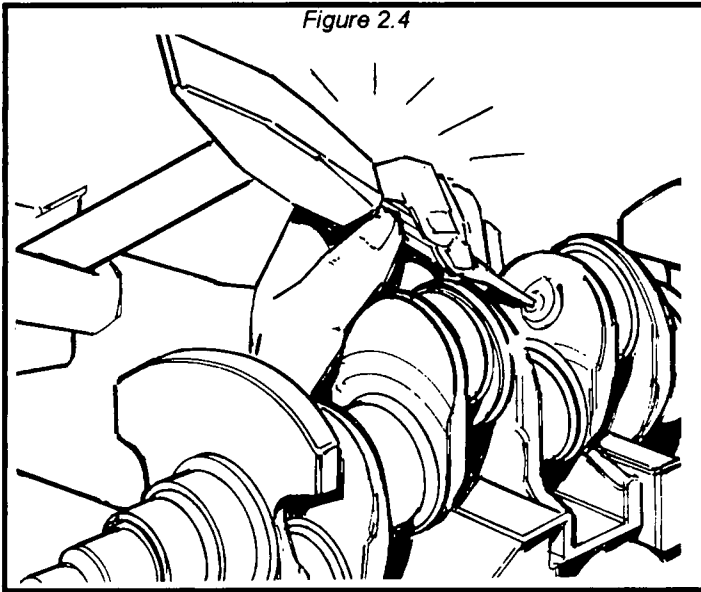

Staking the oil duct plugs (See Figure 2.4)

Figure 2.5

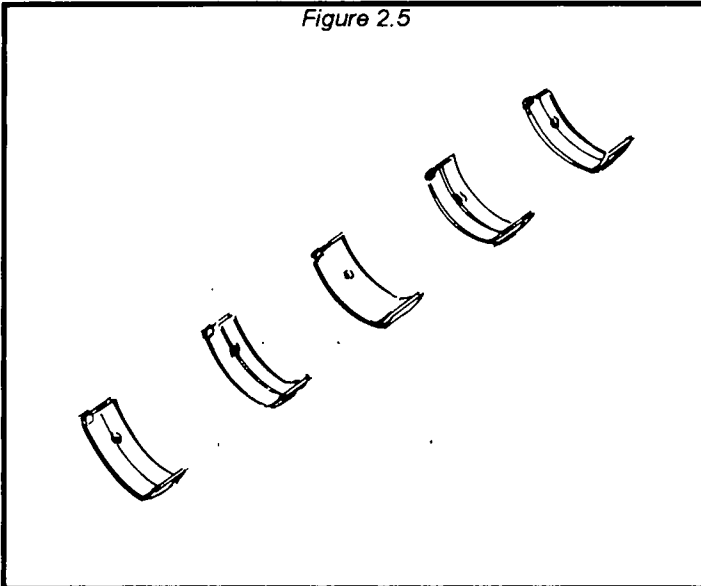

## CRANKSHAFT BEARINGS

### Checking crankshaft bearings

**NOTE:** Crankshaft bearings are available as spares with undersize internal diameters of .010-.020 in. Never carry out any adjustments to the half bearings; therefore if there are any traces of grooves or seizing they must be replaced. Carefully clean the components to be fitted. (See Figure 2.5)

Figure 2.6

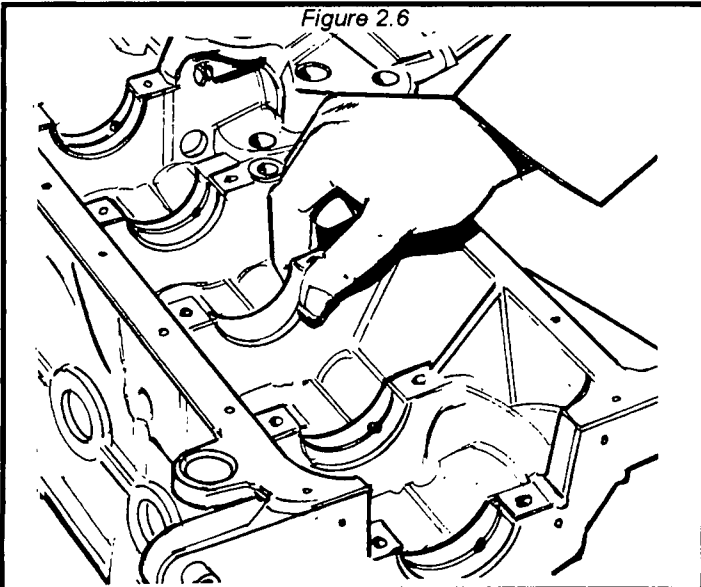

Refitting the crankshaft bearings (Figure 2.6)

**NOTE:** Make sure that each half bearing rests on the entire seat in the engine mounting. Carefully clean the external surfaces of the half bearings and mountings when fitting.

# CRANKSHAFT AND RELATED COMPONENTS

Figure 2.7

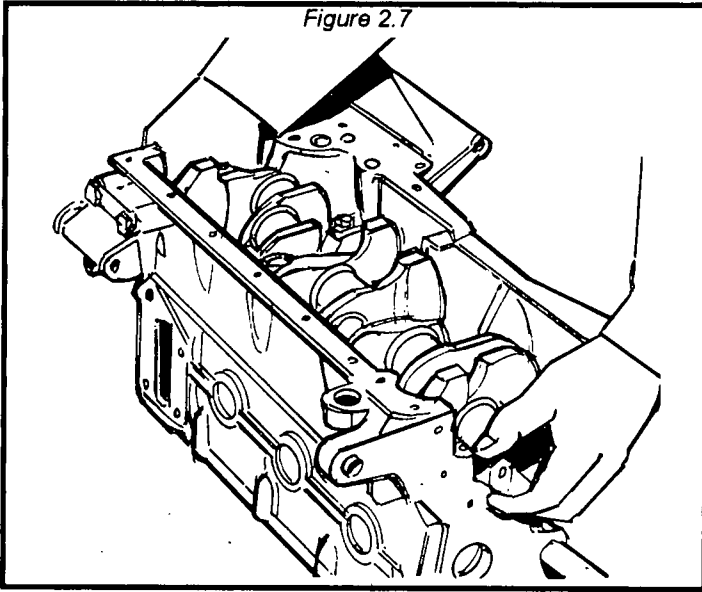

Refitting the Crankshaft (Figure 2.7)

Figure 2.8

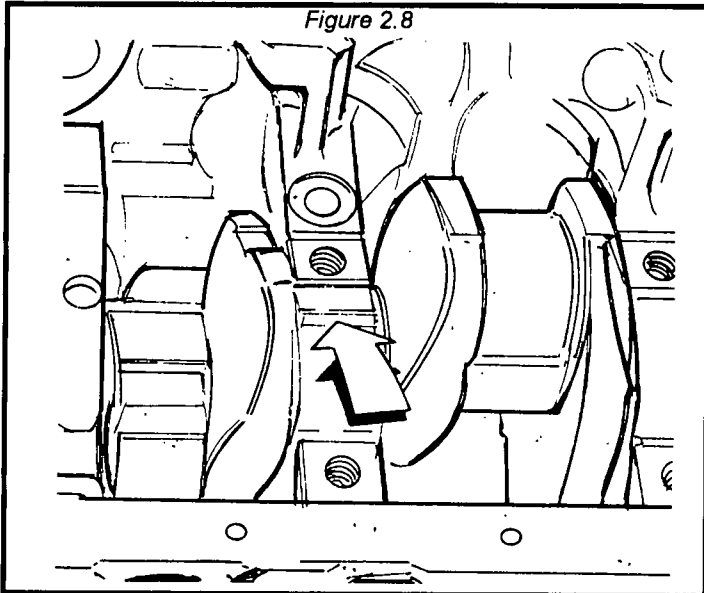

## Measuring main bearing clearances.

Lay a small piece of Plastigauge material on each main bearing surface. (See NOTE)

**NOTE:** Check the bearings one at a time without moving the shaft during the checking process.

Figure 2.9

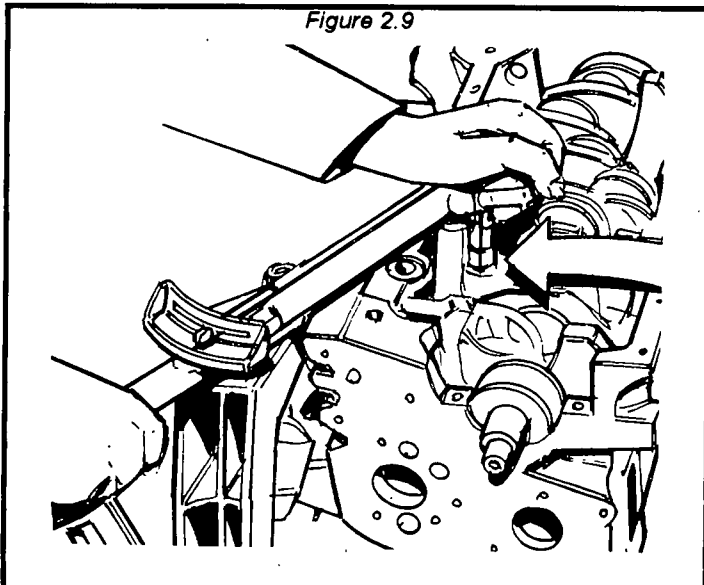

**Tightening the main bearing cap bolts to 59 ft-lb of torque. (second operation)**  
(See Figure 2.9)

# CRANKSHAFT AND RELATED COMPONENTS

Figure 2.10

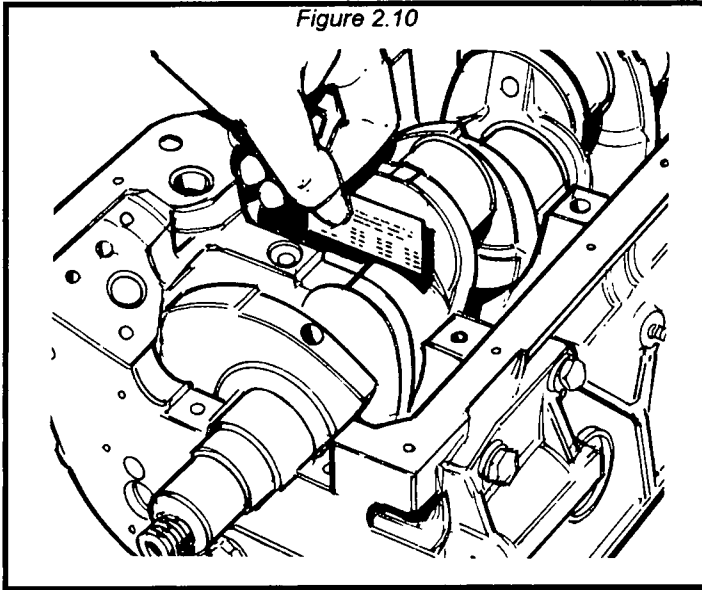

## Measure clearance

Remove the main bearing caps and check the plastigauge measurements to be sure that they are within specification. (.000748-.00196)  
(See Figure 2.10)

Figure 2.11

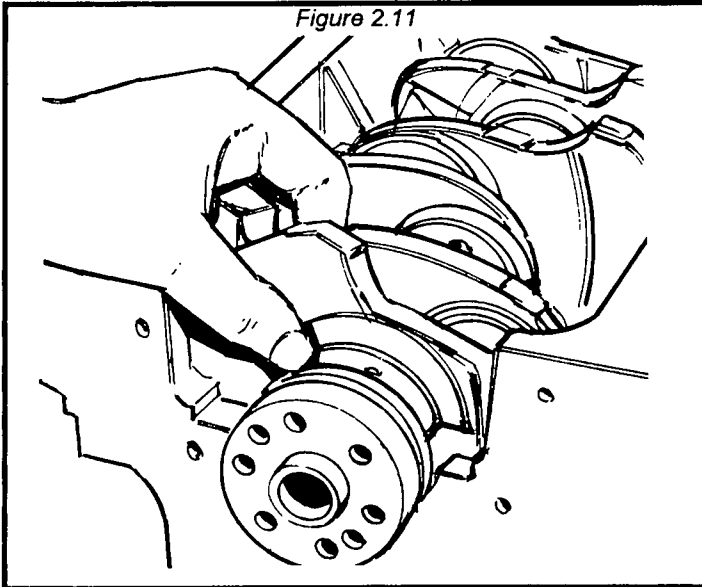

## THRUST WASHERS

### Fitting thrust washers on flywheel side support

Refit the thrust washers with the splined surfaces facing the crankshaft. Lubricate the thrust washers with oil before lubrication. (See Figure 2.11)

Figure 2.12

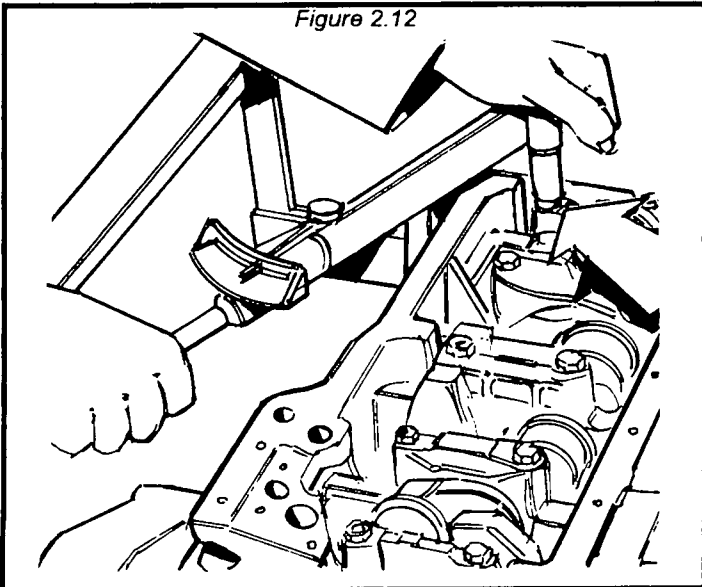

Fitting main bearing caps and tightening caps to 59 ft-lb of torque. (See Figure 2.12)

# CRANKSHAFT AND RELATED COMPONENTS

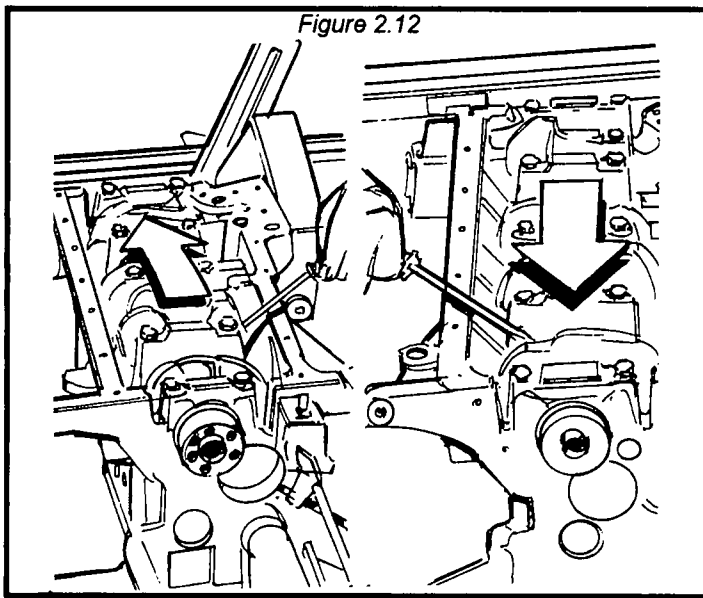

## Checking and measuring crankshaft end play.

Using leverage as shown in the Figure 2.12, move the crankshaft in the opposite direction to the flywheel attachment flange and then zero the dial gauge. Then using leverage as shown in the right hand illustration, move the crankshaft in the oppsite direction and read off the end play value (.002165-.010433 in.) on the dial gauge.

**NOTE:** Thrust washers are available as spares in oversizes of .0050 in.

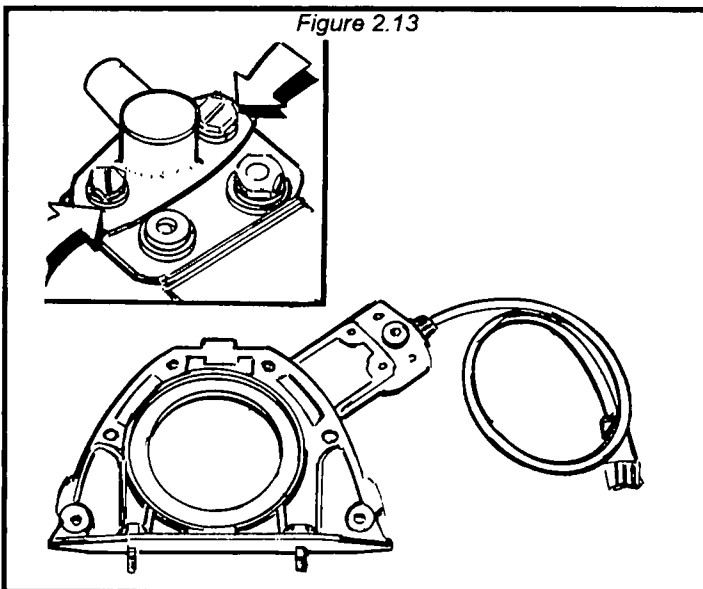

## CRANKSHAFT REAR COVER

View of crankshaft cover. (Figure 2.13)

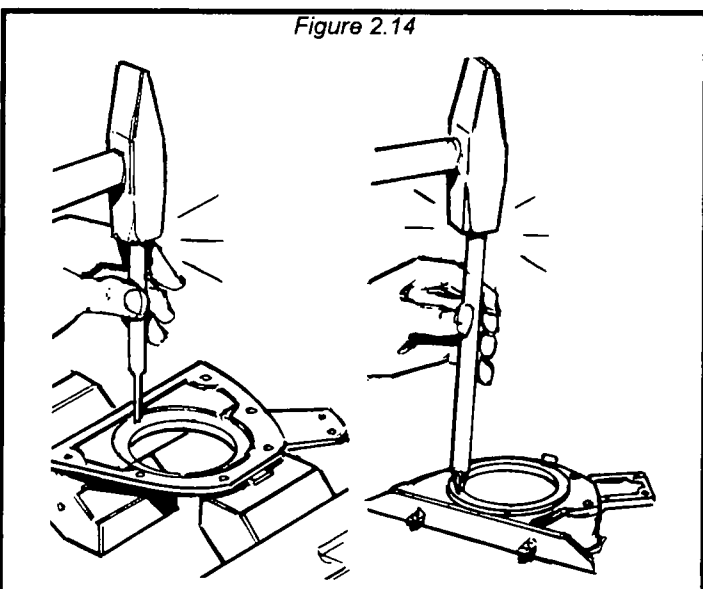

## Removing-refitting crankshaft rear cover seal

**NOTE:** The seal should be removed using a drift inserted in the special spline on the cover internal surface. (See Figure 2.14)

# CRANKSHAFT AND RELATED COMPONENTS

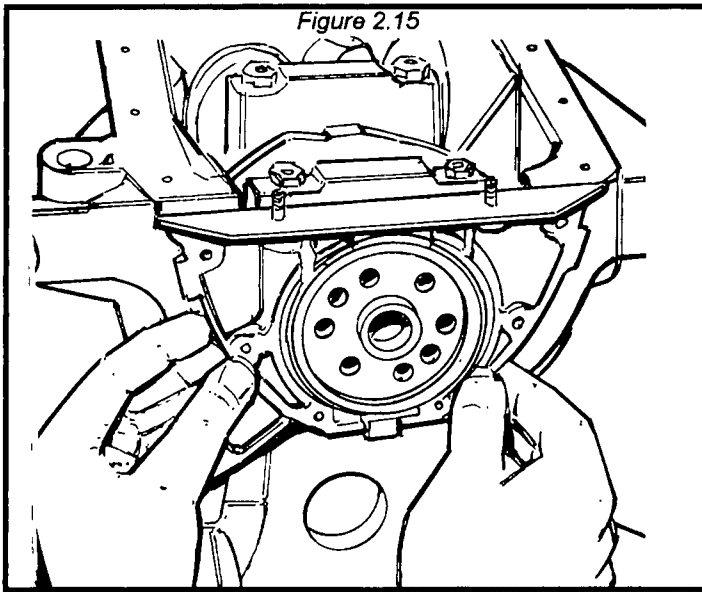

**Refitting crankshaft rear cover on cylinder block / crankcase.**

Before fitting the cover on the cylinder block / crankcase, lubricate the lip of the seal and the gasket support surfaces. (See Figure 2.15)

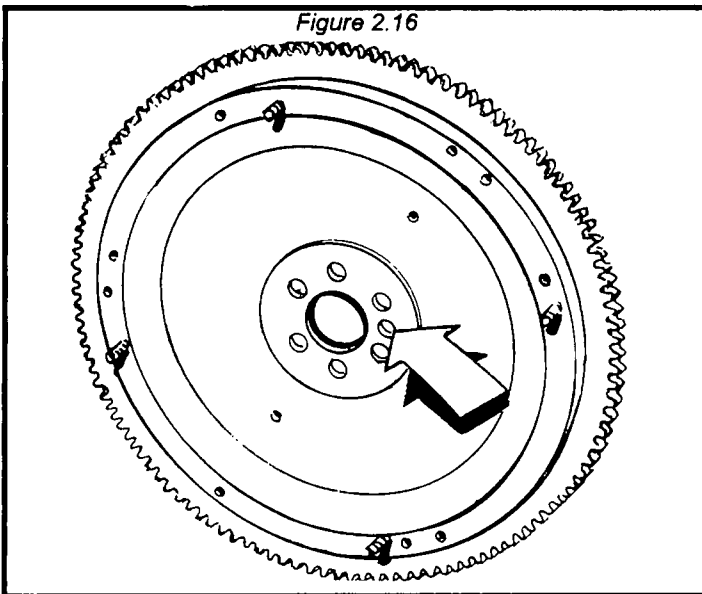

**FLEX-PLATE** (See Figure 2.16)

**NOTE:** If the ring gear needs replacing, heat the new one in the oven to approximately 80° C and fit it on the flexplate with the bevel on the internal diameter turned to towards the actual flexplate. Use an ordinary steel drift when removing.

The flexplate features an extra opening on the flange connected to the crankshaft (shown by the arrow in Figure 2.16) in order to house the centering bushing on the crankshaft and prevent the flexplate from being fitted in an incorrect position.

# CRANKSHAFT AND RELATED COMPONENTS

Figure 2.17

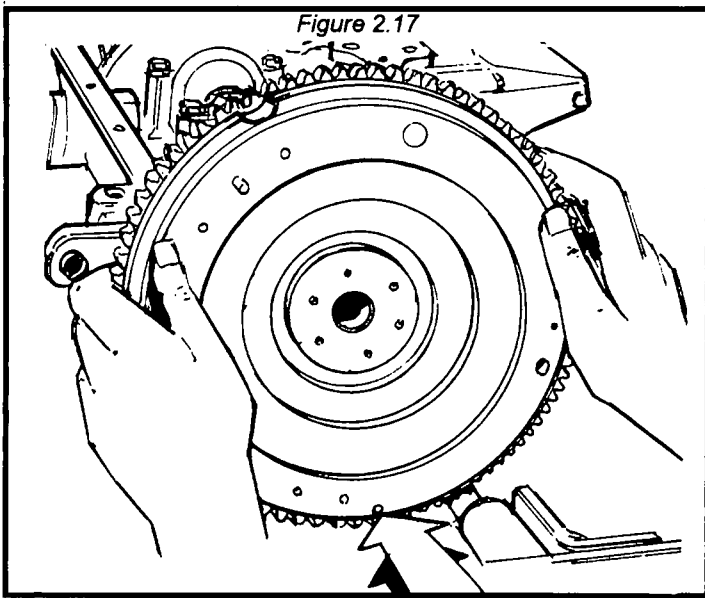

Refitting flexplate (See Figure 2.17)

**NOTE:** Position the crankshaft with the crankpins for cylinders 1 and 4 at TDC, then fit the flexplate with the reference mark showing TDC facing the cylinder head support plane.

Figure 2.18

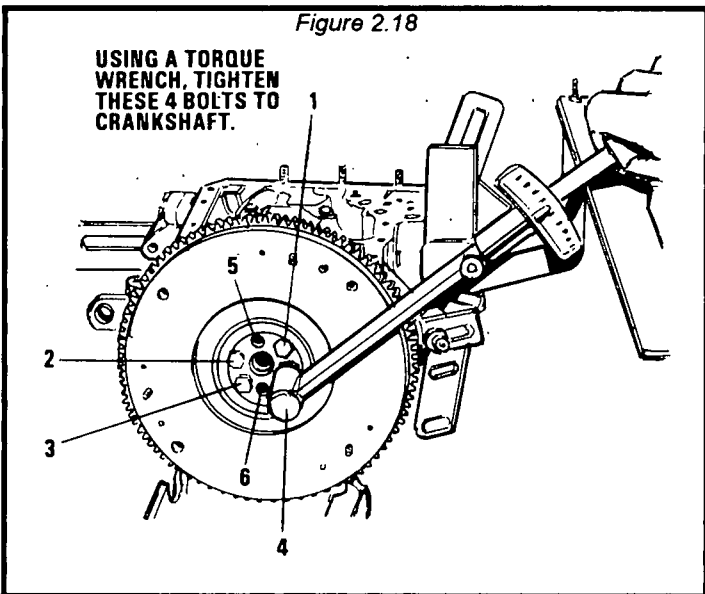

Tightening flexplate bolts (See Figure 2.18)

Install the flywheel lock.

**NOTE:** Only tighten the four bolts to specification, (61 ft-lb) leaving two openings opposite each other free, as shown by the arrows, in order to fit the flexplate lock. The remaining two bolts should be fitted and tightened to specification when the flexplate lock is removed at the end of the engine reassembly operations.

Figure 2.19

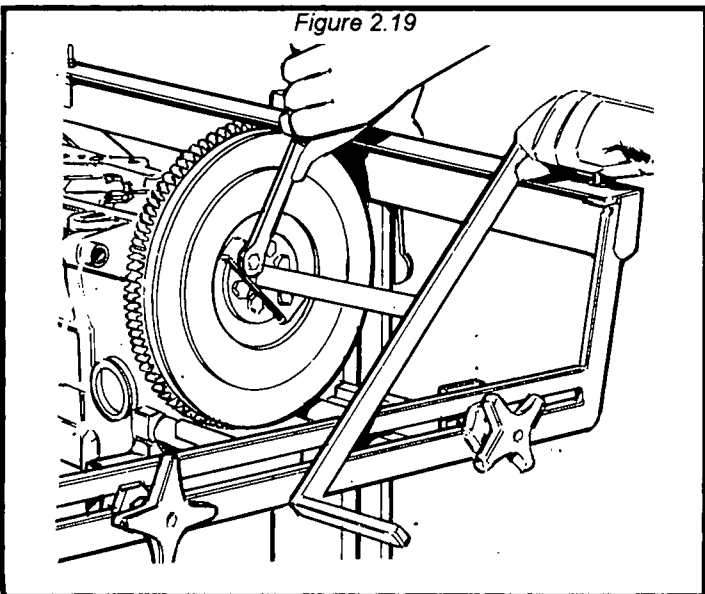

Fitting handle for rotating crankshaft.

Remove the flexplate lock. (See Figure 2.19)

# CRANKSHAFT AND RELATED COMPONENTS

Figure 2.20

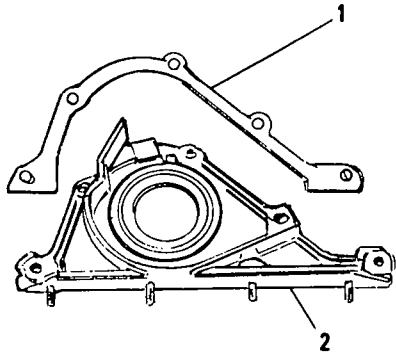

## CRANKSHAFT FRONT COVER

The gasket (1) support surfaces and the lip of the seal (2) as shown in Figure 2.20.

Figure 2.21

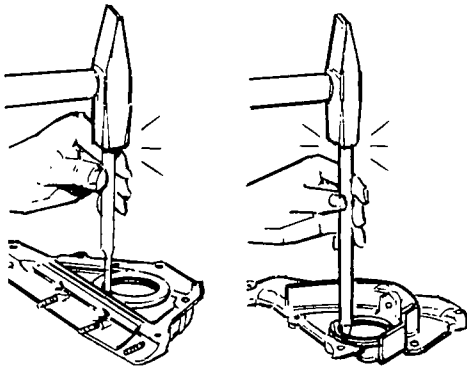

## Removing and refitting crankshaft front seal

**NOTE:** The seal should be removed using a drift inserted in the special spline in the internal surface on the cover. (See Figure 2.21)

Figure 2.22

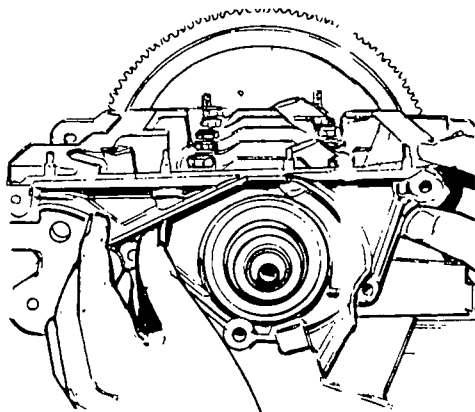

## Refitting crankshaft front cover on cylinder block / crankcase.

Before fitting the cover on the cylinder block / crankcase, lubricate the lip of the seal and the gasket support surfaces. (See Figure 2.22)

# CYLINDER HEAD INSPECTION / REPAIR

Figure 3.1

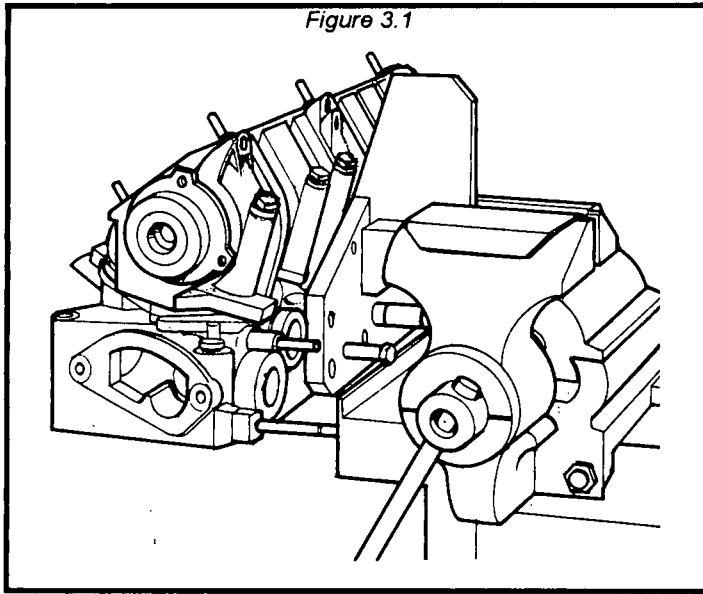

## DISMANTLING CYLINDER HEAD

**NOTE:** Before beginning the operations of dismantling and overhauling, attach the cylinder head to a suitable retaining device, and remove all of the spark plugs. (See Figure 3.1)

Figure 3.2

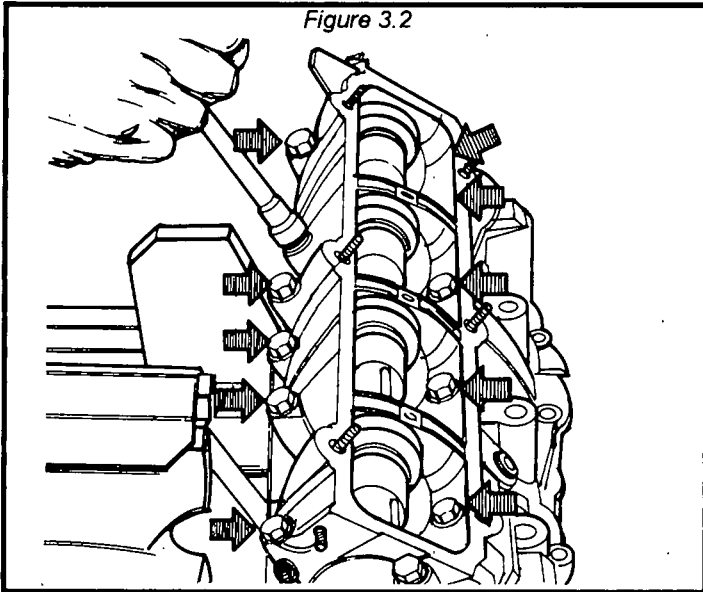

## Dismantling camshaft housing

**NOTE:** The arrows show the bolts which attach the camshaft housing to the cylinder head. (See Figure 3.2)

Figure 3.3

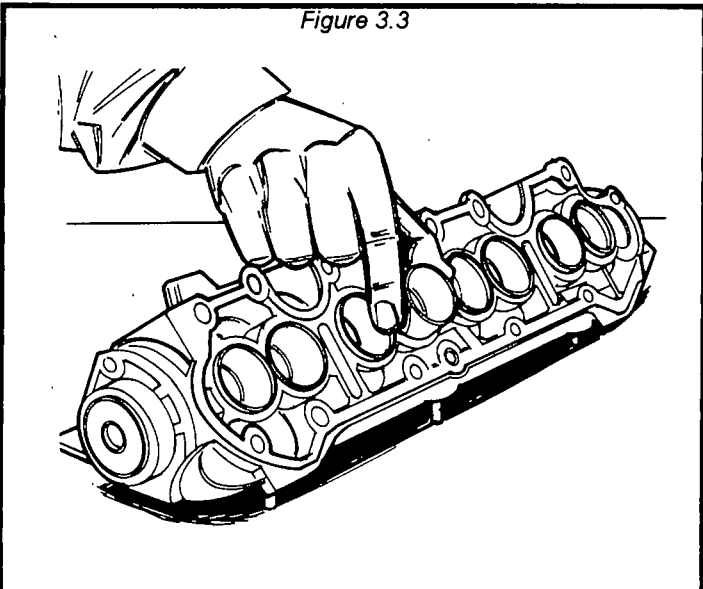

## Removing tappets

Make sure that the tappets are refitted in the correct housings. Number them accordingly to assure a proper refit. (See Figure 3.3)

# CRANKSHAFT AND RELATED COMPONENTS

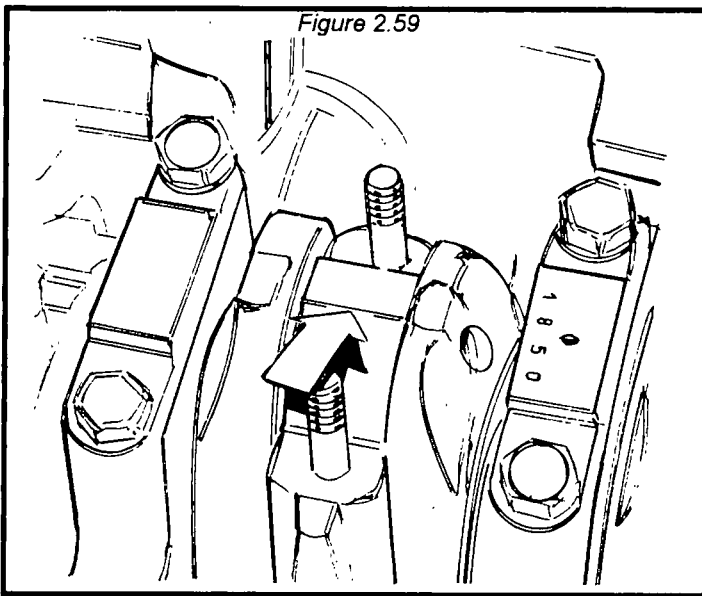

**Measuring connecting rod bearing clearance**  
Place a small piece of plastigauge on each rod throw of the crankshaft one rod at a time.  
(See Figure 2.59)

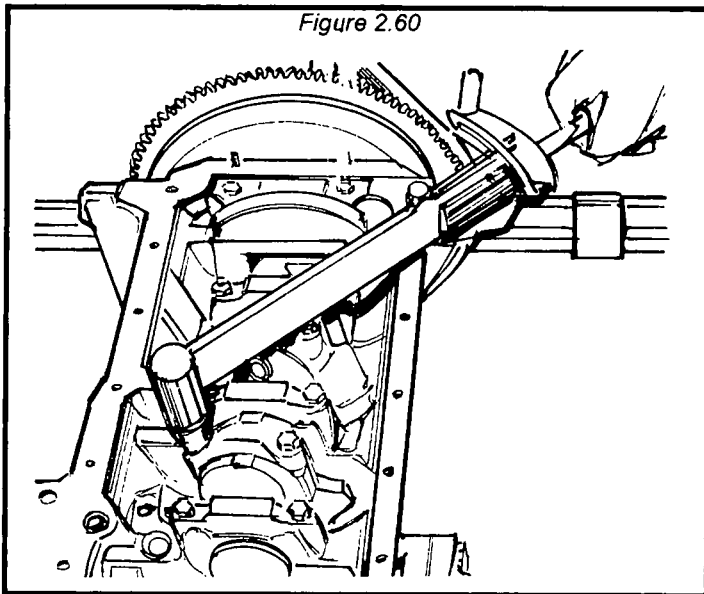

Torque the connecting rod cap on to specification. **(37.5 ft-lb)** (See Figure 2.60)

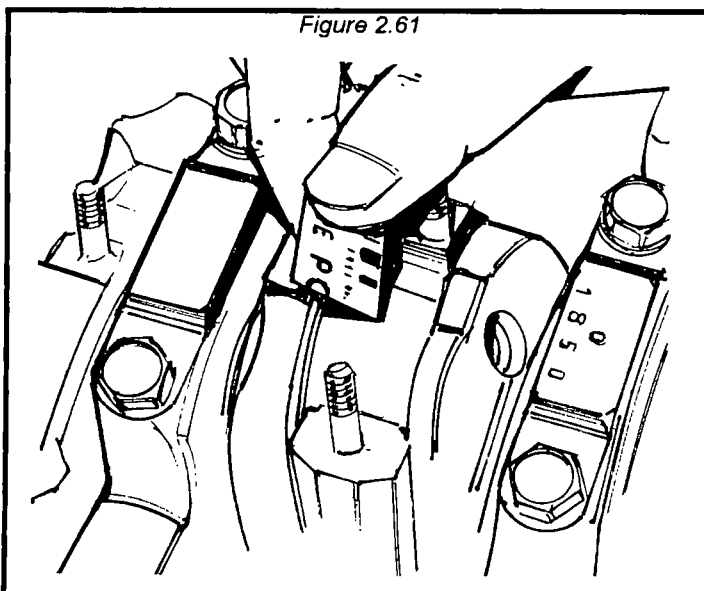

Remove the connecting rod cap and measure the plastigauge with the paper gauge. The allowed tolerance is **(.00098-.0024 in.)** Lubricate all the concerned parts before final assembly.  
(See Figure 2.61)

# CRANKSHAFT AND RELATED COMPONENTS

Figure 2.57

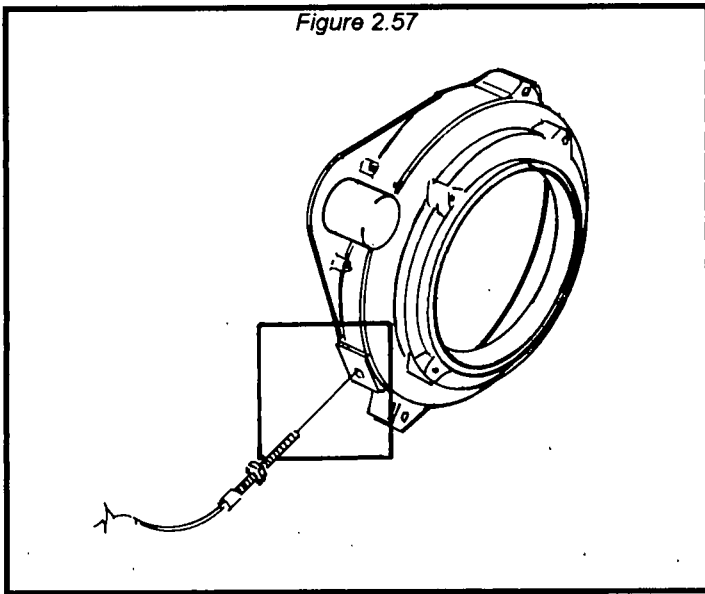

## RPM sensor

The RPM sensor is located on the left hand side of the blower housing. (See Figure 2.57)

**NOTE:** This sensor is used exclusively on C-optional units only.

Figure 2.58

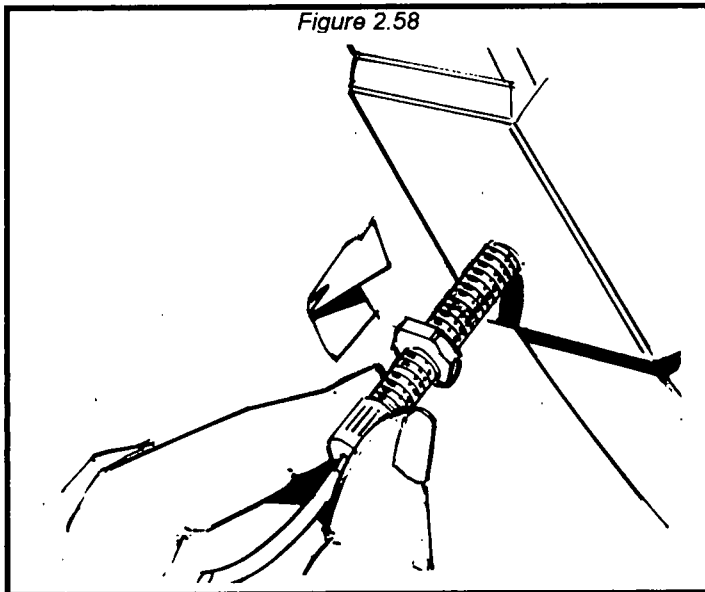

## Testing the RPM sensor

When testing the RPM sensor, it should read at least one (1) volt.

To install a new RPM sensor, after the removal of the old sensor, thread the new sensor in place until it lightly makes contact with the flywheel ring gear, then back the sensor out  $\frac{3}{4}$  turn. (See Figure 2.58).

# CRANKSHAFT AND RELATED COMPONENTS

Figure 2.54

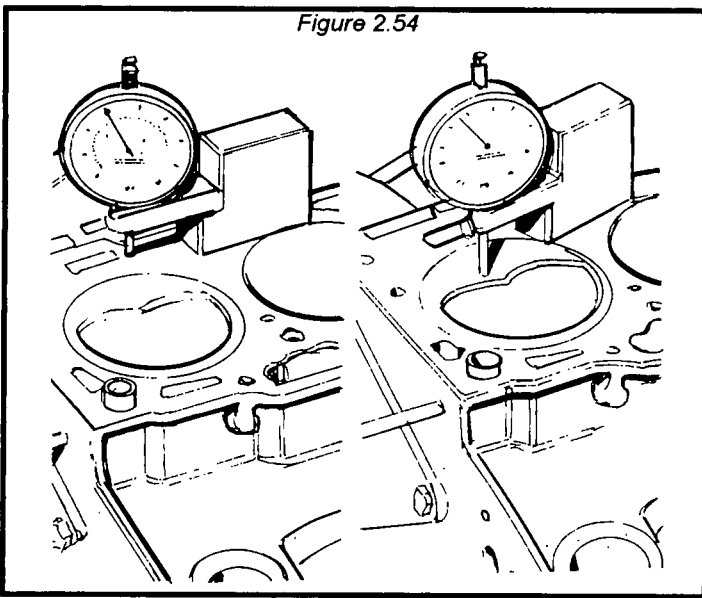

**Measuring connecting rod bearing clearance**  
Lay a small piece of plastigauge on the connecting rod bearing journal to measure the bearing clearances as shown in Figure 2.54.

Figure 2.55

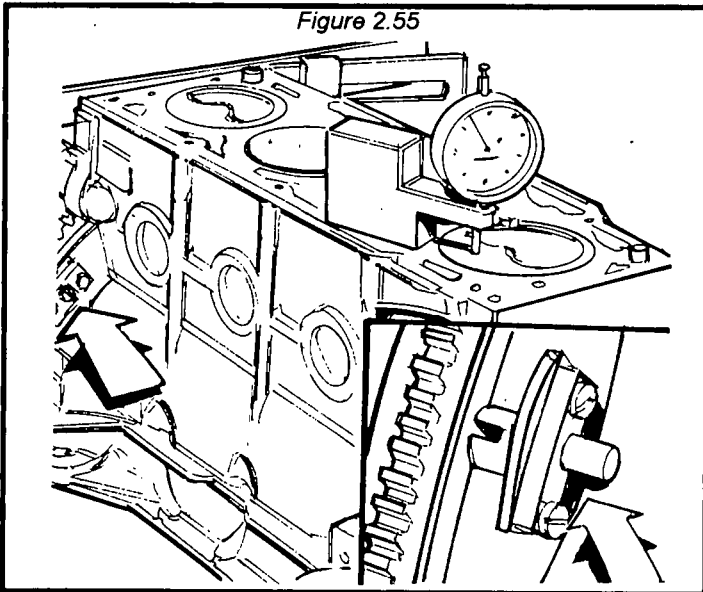

Tighten the connecting rod nuts to their specified torque (**37.5 ft-lb**) (See Figure 2.55)

**Measuring the bearing clearance after the rod caps have been torqued.**

After torquing the connecting rod caps, remove them and check the measurement of the plastigauge to make sure it's within specification. (**.0098-.0024 in.**)

# CRANKSHAFT AND RELATED COMPONENTS

Figure 2.51

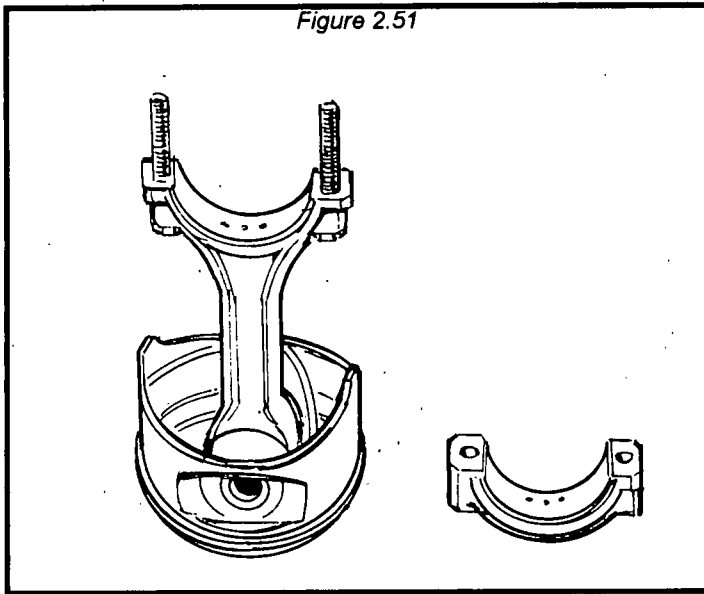

## BIG END BEARINGS

Fitting big end rod bearings.

**NOTE:** Big end bearings are available as spares with undersize diameters of (.01 and .02 in). (See Figure 2.51)

Do not carry out any adjustments to the bearings; therefore if there are any traces of grooves or seizing they must be replaced.

Carefully clean the components when fitting.

Figure 2.52

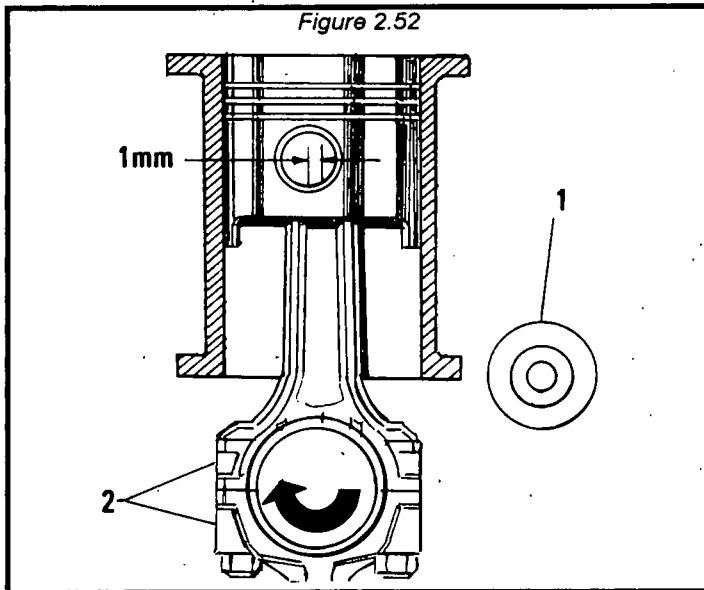

Connecting rod and piston assembly showing engine rotation direction

1. Auxiliary shaft

2. Area where matching number of connecting rod to cylinder bore is stamped.

.393 in. = Gudgeon pin offset on the piston

The arrow shows the direction of rotation of the engine as seen from the timing side.

**NOTE:** Make sure when fitting the connecting rod and piston / rod assembly that the number of the cylinder bore to which the connecting rod belongs is opposite the oil vapor breather hole in the cylinder block / crankcase.

Figure 2.53

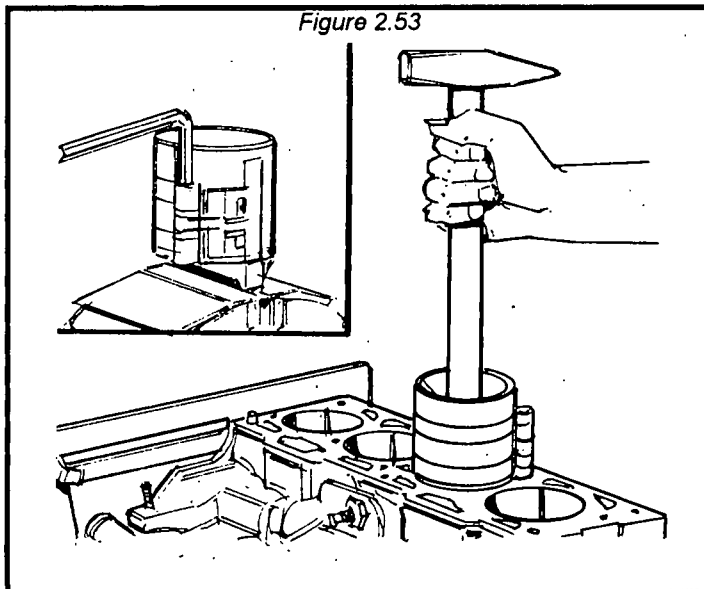

Fitting connecting rod - gudgeon (wrist) pin piston assembly in cylinder bore

(See Figure 2.53)

**NOTE:** Be sure to oil all concerned parts with oil prior to engine assembly.

# CRANKSHAFT AND RELATED COMPONENTS

Figure 2.48

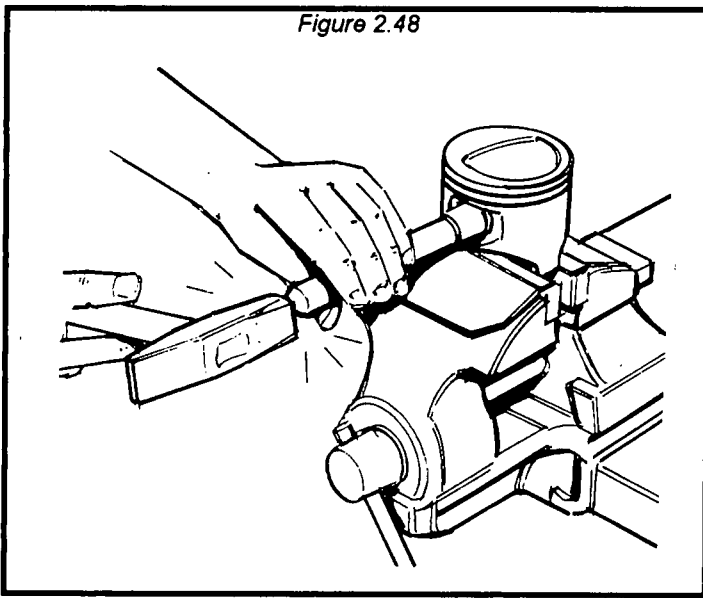

Fitting the gudgeon (wrist) pin in connecting rod piston assembly (See Figure 2.48)

**NOTE:** Fit the piston in the connecting rod positioning it so that the flat part of the crown is facing the same way as the number indicating the cylinder bore to which the connecting rod belongs. If the connecting rod is being replaced, the number of the cylinder to which it belongs is stamped near the piston grade.

Figure 2.49

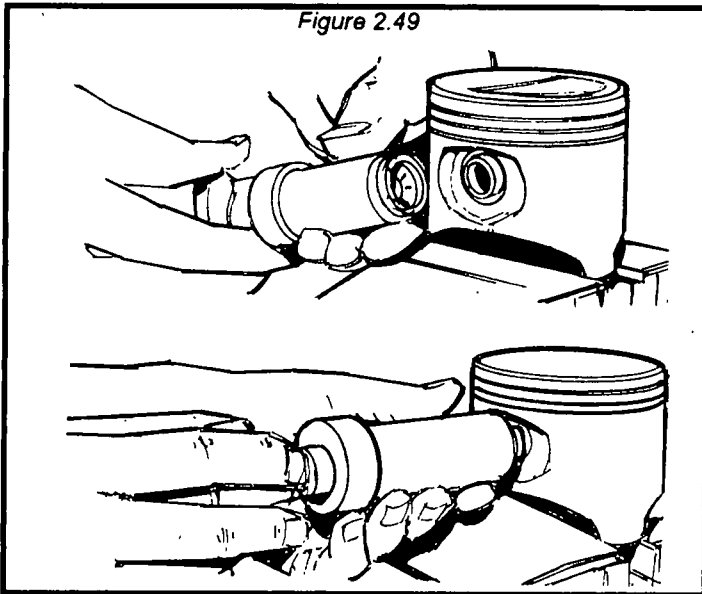

Fitting the gudgeon (wrist) pin circlips

Using a piston pin clip installation tool, install the pin clips in the manor as shown in Figure 2.49.

Figure 2.50

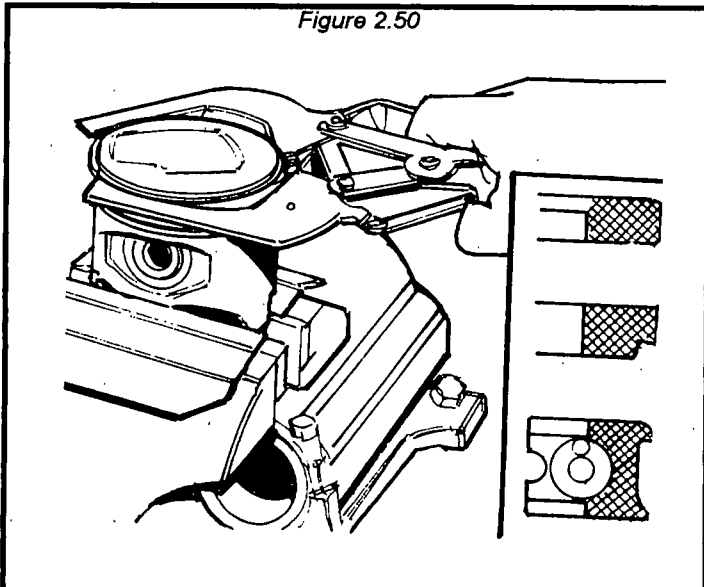

Fitting and positioning piston rings on pistons.

The piston rings should be fitted with the word "TOP" upwards.

After fitting, turn the piston rings so that they are offset 120° from each other. (See Figure 2.50)

# CRANKSHAFT AND RELATED COMPONENTS

Figure 2.45

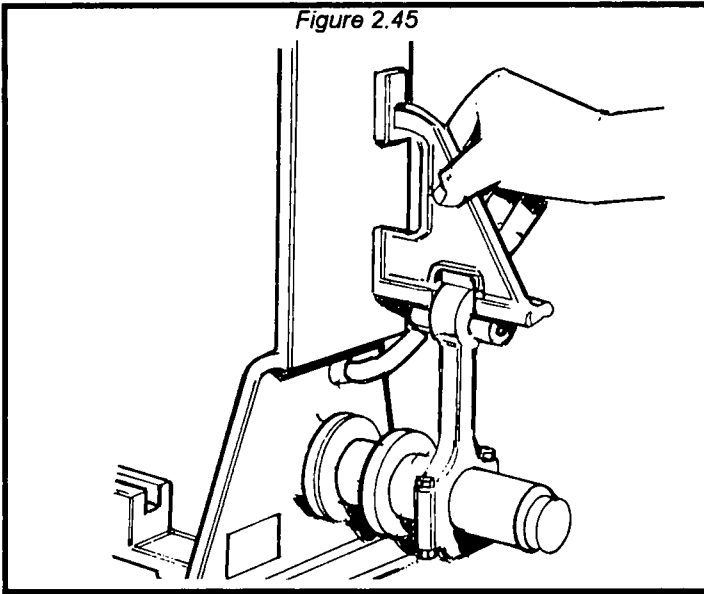

**Connecting rod alignment check.**  
(See Figure 2.45)

Figure 2.46

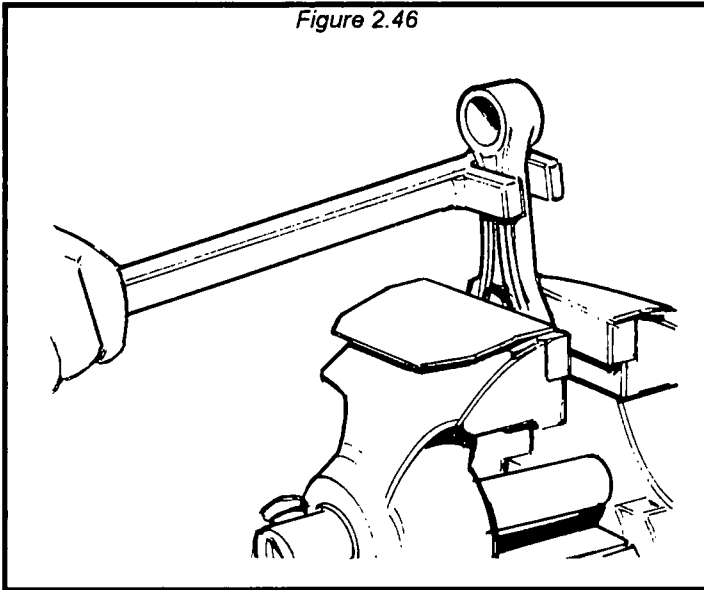

**Connecting rod straightening**  
(See Figure 2.46)

**NOTE:** It is recommended to replace a bent connecting rod rather than straighten it.

Figure 2.47

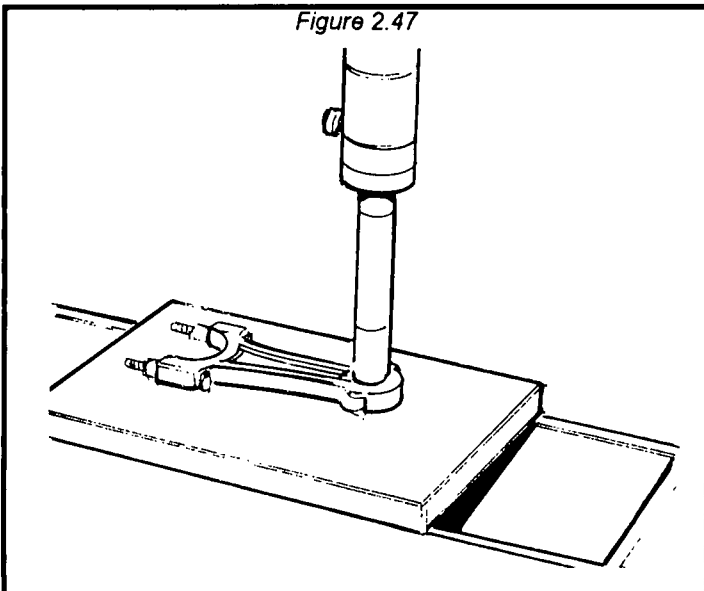

**BUSHES**  
**Removing and refitting small end bushing**  
(See Figure 2.47)

# CRANKSHAFT AND RELATED COMPONENTS

Figure 2.41

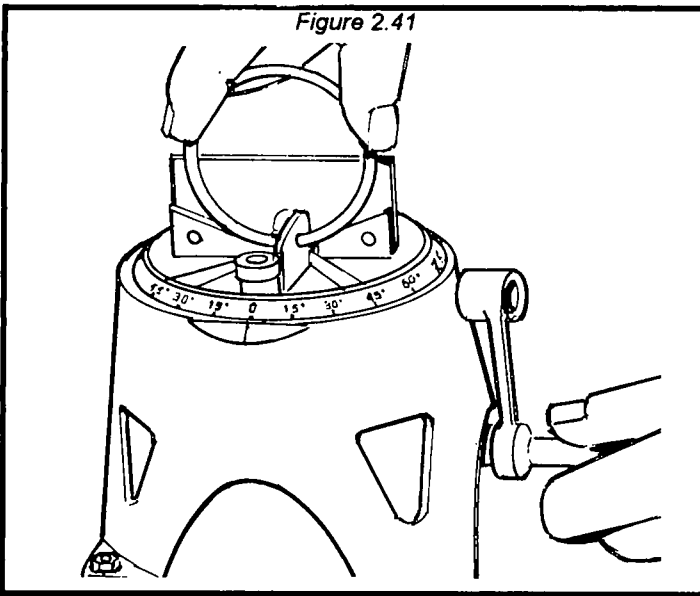

## Gapping the piston rings

The piston rings are also available as spares in oversizes of .01574 in.. To properly fit the piston rings you must use a ring file as shown in (Figure 2.41).

Figure 2.42

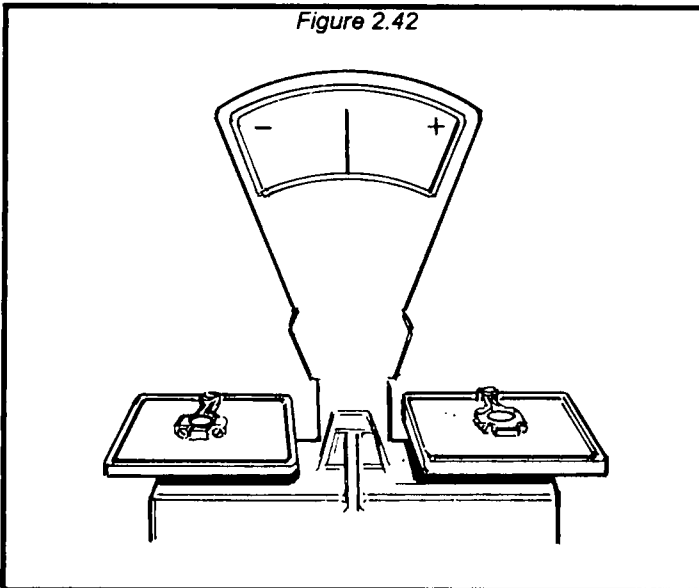

## CONNECTING RODS

### Checking weight of connecting rods

If the connecting rod has to be replaced, the number of the cylinder to which it belongs is stamped on the area opposite the half bearing retainer notches. (see Figure 2.42)

Figure 2.43

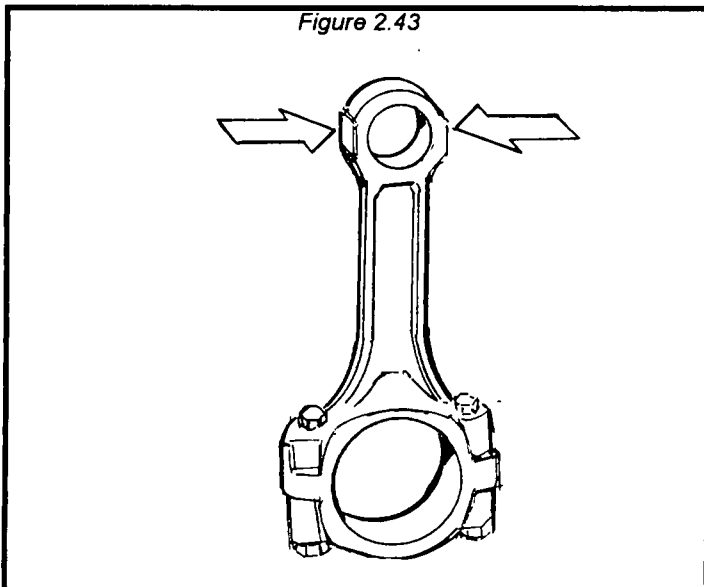

### Areas for removing excess weight

The arrows show where to remove any excess weight from the connecting rod. (See Figure 2.43)

# CRANKSHAFT AND RELATED COMPONENTS

Figure 2.38

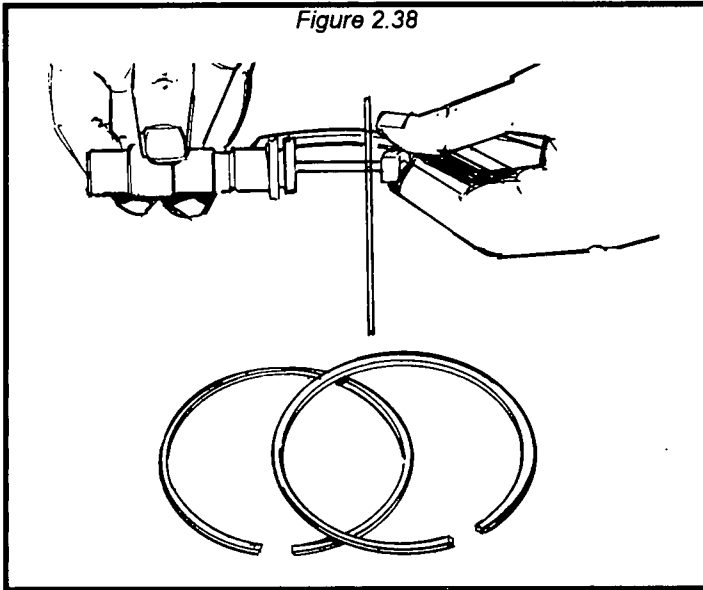

## PISTON RINGS

Ring #1	.0581-.05866 in.
Ring #2	.0680-.0685 in.
Ring #3	.117-.1177 in.

Measuring piston ring thickness  
(See Figure 2.38)

Figure 2.39

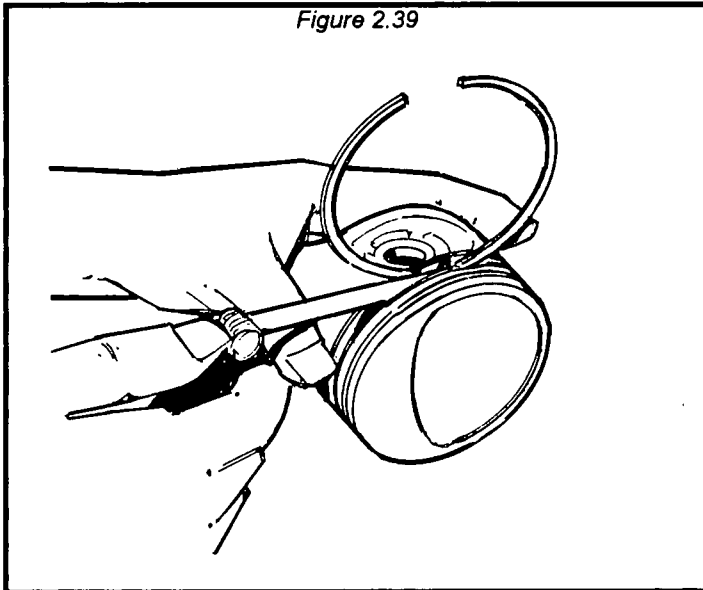

Checking clearance between piston rings and grooves (See Figure 2.39)

Ring #1	.0017-.0030 in.
Ring #2	.0016-.0028 in.
Ring #3	.0012-.0026 in.

Figure 2.40

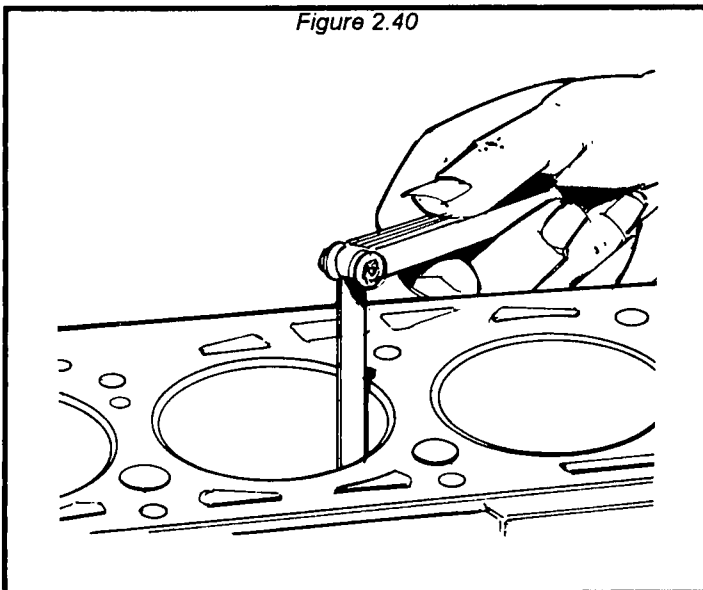

Checking and measuring clearance between edges of piston rings (See Figure 2.40)

Ring #1	.012-.0197 in.
Ring #2	.012-.0197 in.
Ring #3	.0098-.0197 in.

# CRANKSHAFT AND RELATED COMPONENTS

Figure 2.35

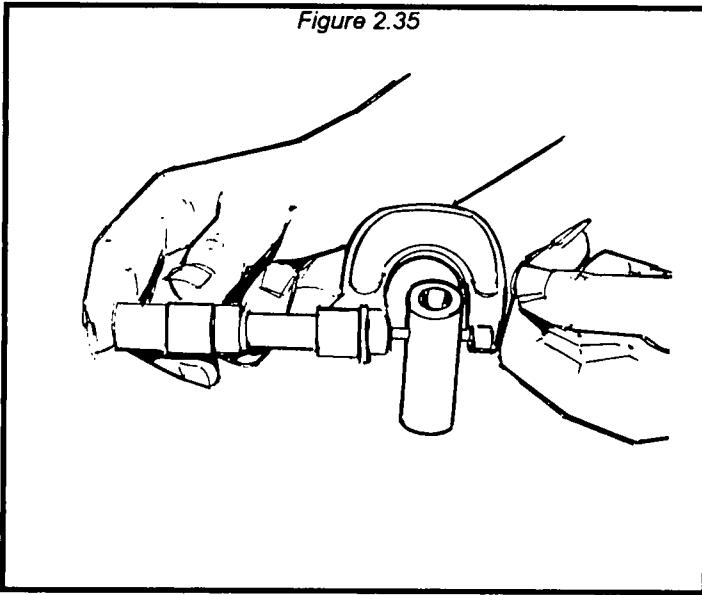

**Measuring gudgeon (wrist) pin diameter**  
Normal gudgeon (wrist) pins are graded and mated to the pistons.

**NOTE:** Pins are available as spares in **(.00787 in.)** oversize diameters.

Surface 1 diameter	.86578-.8659 in.
Surface 2 diameter	.8659-.8660 in.

Figure 2.36

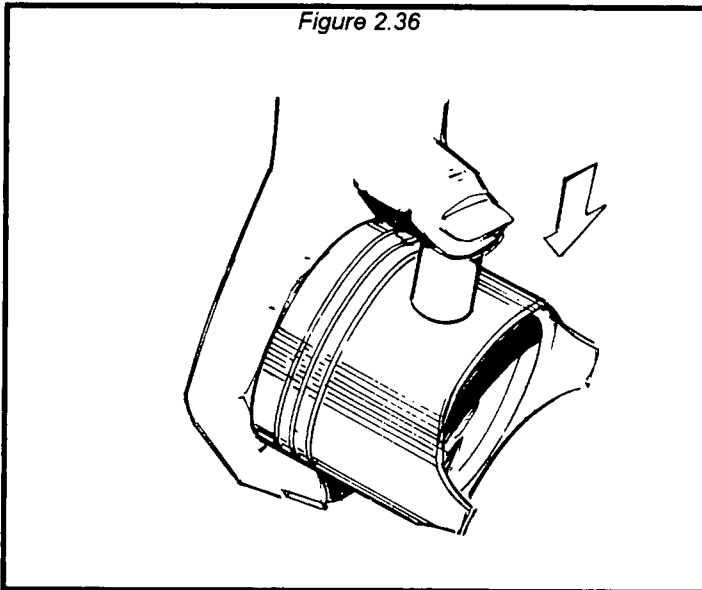

**Conditions for a correct gudgeon (wrist) pin fit**

The gudgeon (wrist) pin should be a push fit in the piston. **(.0000787-.0003149 in)** between wrist pin and piston wrist pin bore. (See Figure 2.36)

Figure 2.37

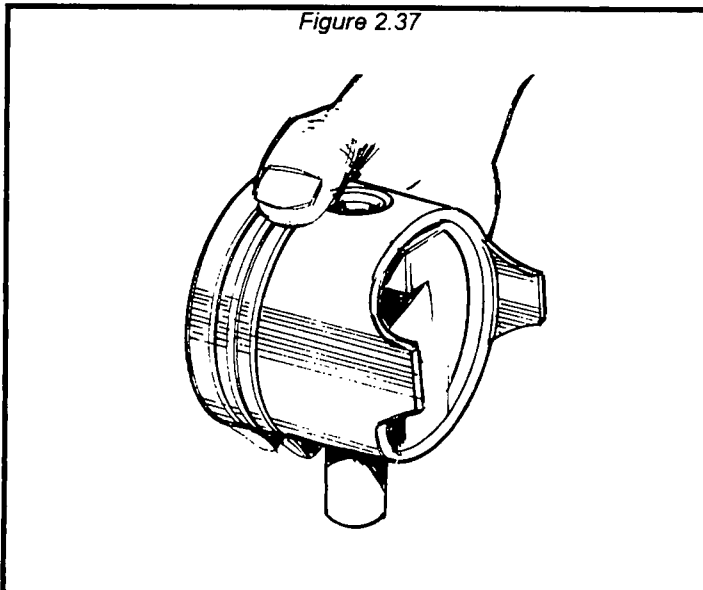

The gudgeon pin should not come out of the piston. (See Figure 2.37)

# CRANKSHAFT AND RELATED COMPONENTS

Figure 2.32

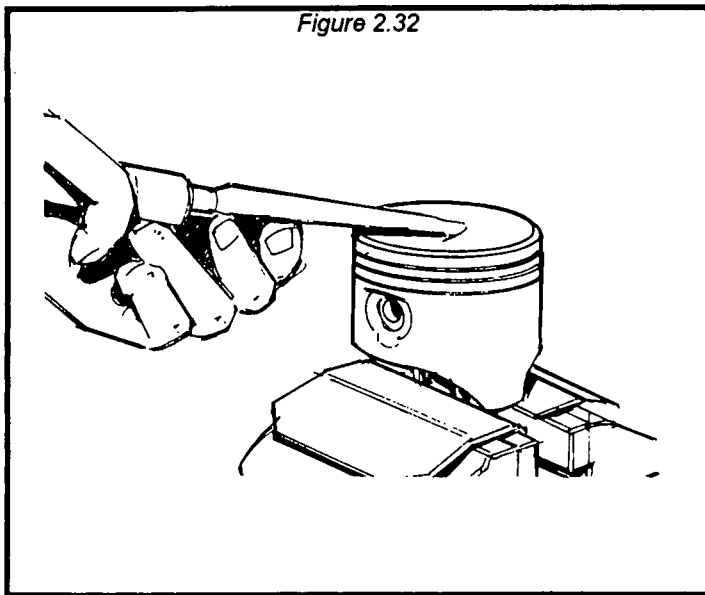

**Cleaning piston crown (See Figure 2.32)**

**NOTE:** It is very important to clean the tops of the pistons if they are within specification to be reused so that they are free of all built up carbon deposits.

Figure 2.33

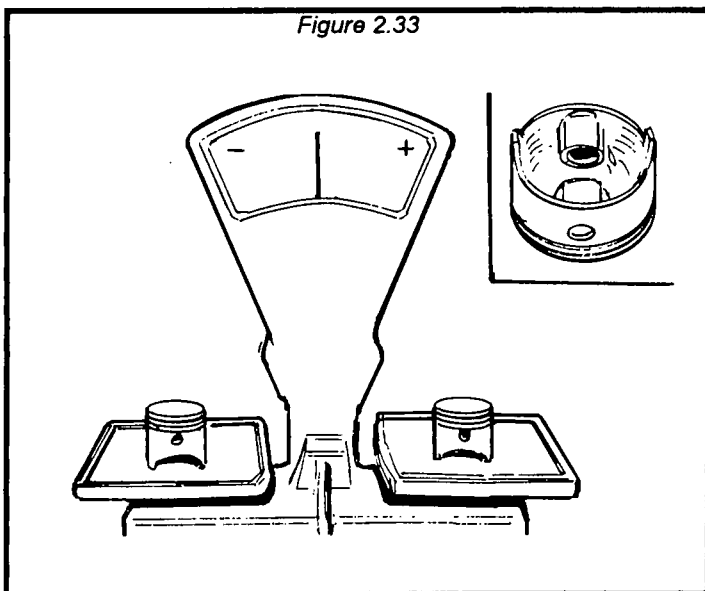

**Checking the prescribed tolerance for the piston weight**

**NOTE:** The arrows show the areas from which excess material must be removed to equalize the weight.  $\pm 2.5$  g. (See Figure 2.33)

Figure 2.34

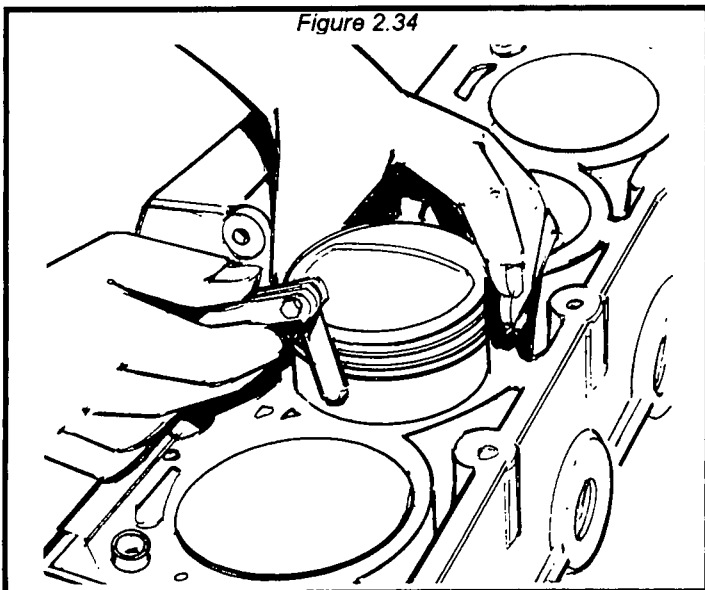

**Checking fitting clearance between piston and cylinder bore ( .00118-.001968 in.)(See Figure 2.34)**

# CRANKSHAFT AND RELATED COMPONENTS

Figure 2.29

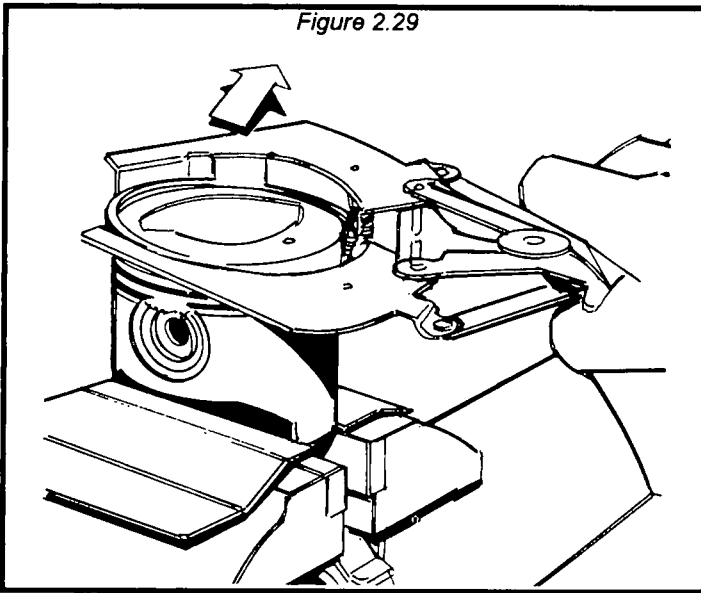

## Piston and connecting rod preparation

Remove old piston rings with a piston ring tool.  
(See Figure 2.29)

Figure 2.30

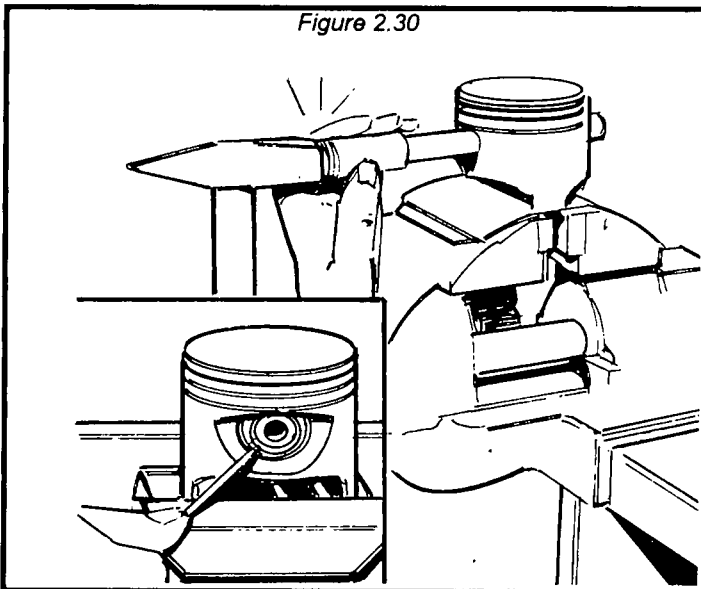

## Removing gudgeon (wrist) pins

**NOTE:** If the components are free from faults they can be reused; care must therefore be taken to mark parts belonging to the same group.

Figure 2.31

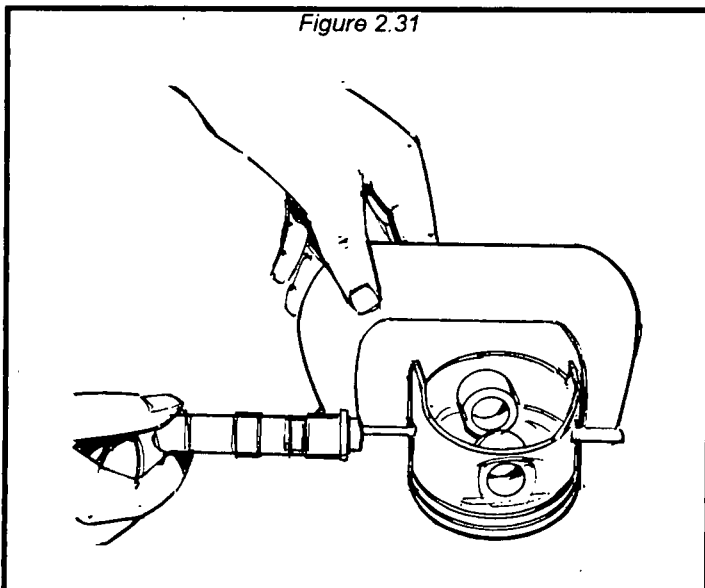

## PISTONS

### Measuring piston diameters (See Figure 2.31)

Normal: Graded like the cylinder bores in f grades of 0.01 mm: (A - B - C - D - E)

as spares only A - C - E.

Oversize: .015 in.

with no graded bores or gudgeon (w) sizes.

\*Number showing gudgeon

\*\*Letter showing piston

# CRANKSHAFT AND RELATED COMPONENTS

Figure 2.26

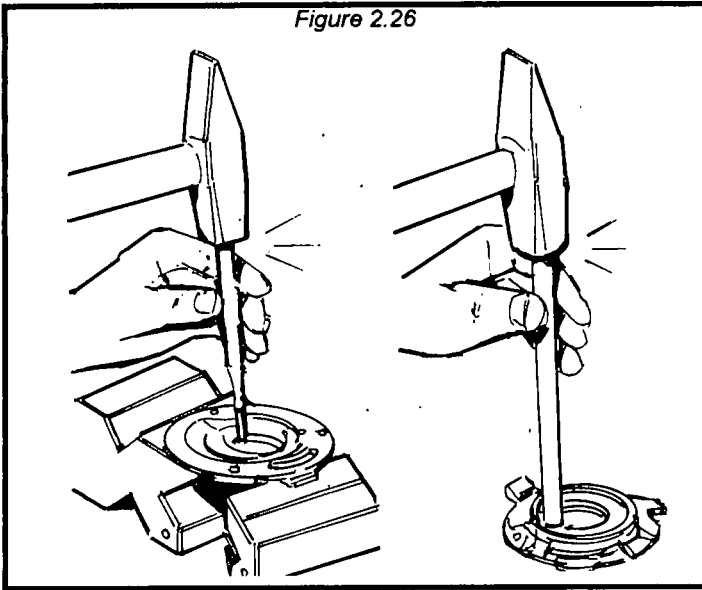

## Removing-refitting auxiliary shaft cover seal

**NOTE:** The seal should be removed using a drift inserted in the special spline in the internal surface of the cover. (See Figure 2.26)

Figure 2.27

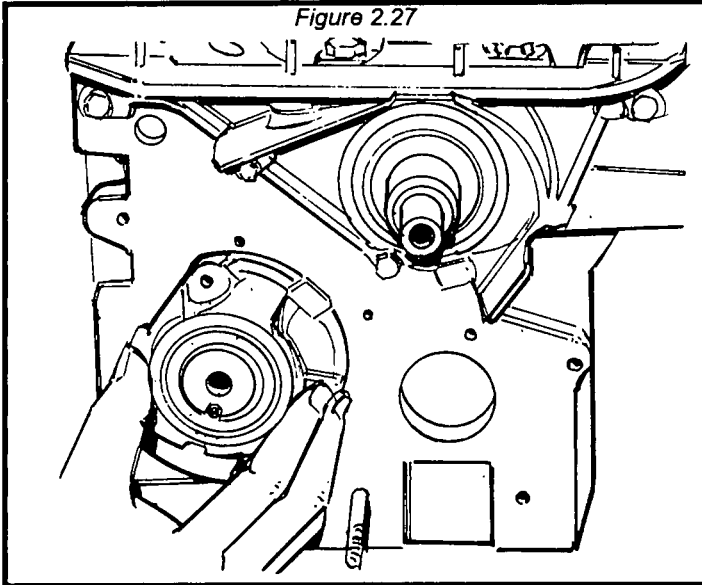

## Refitting auxiliary shaft cover on cylinder block / crankcase

Before refitting the cover on the cylinder block / crankcase, lubricate the lip of the seal and gasket support surface. (See Figure 2.27)

Figure 2.28

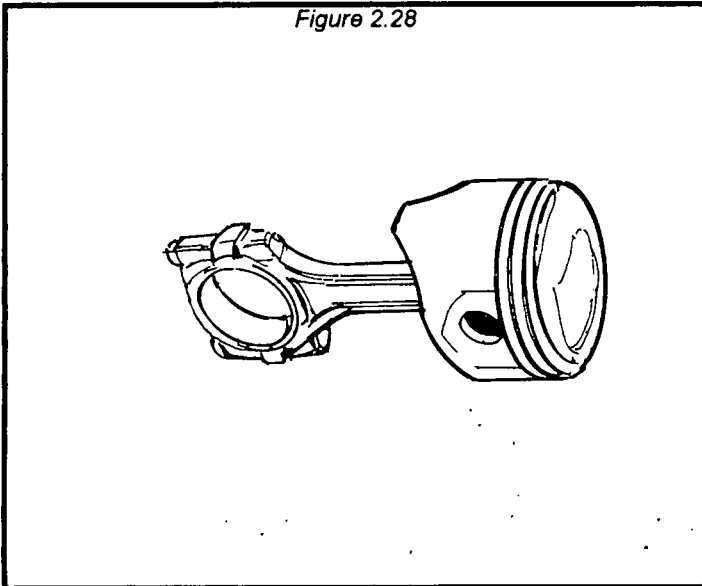

## CONNECTING ROD-PISTON ASSEMBLY View of connecting rod-piston assembly (See Figure 2.28)

# CRANKSHAFT AND RELATED COMPONENTS

Figure 2.23

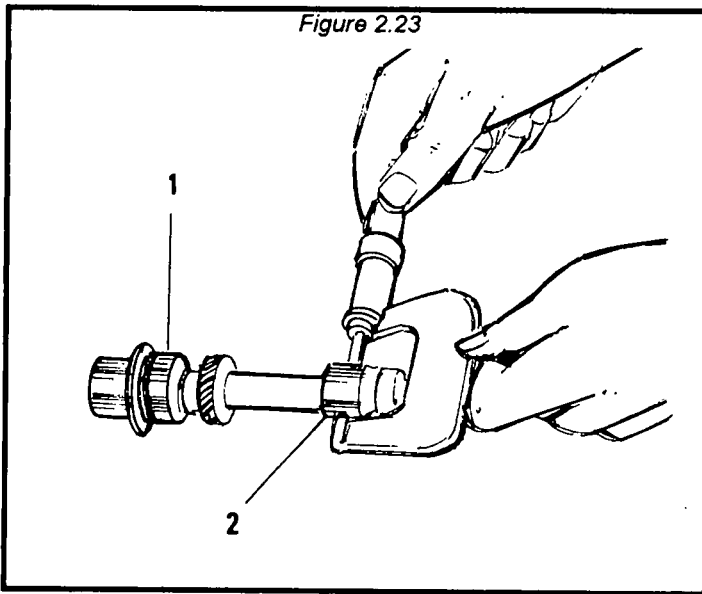

## AUXILIARY SHAFT

Surface 1 diameter	1.4013-1.4023 in.
Surface 2 diameter	1.2575-1.2583 in.

### Measuring auxiliary shaft bearings

**NOTE:** There must not be any traces of seizing or scoring on the surface of the bearings or the gear or else the actual shaft will have to be replaced.

Figure 2.24

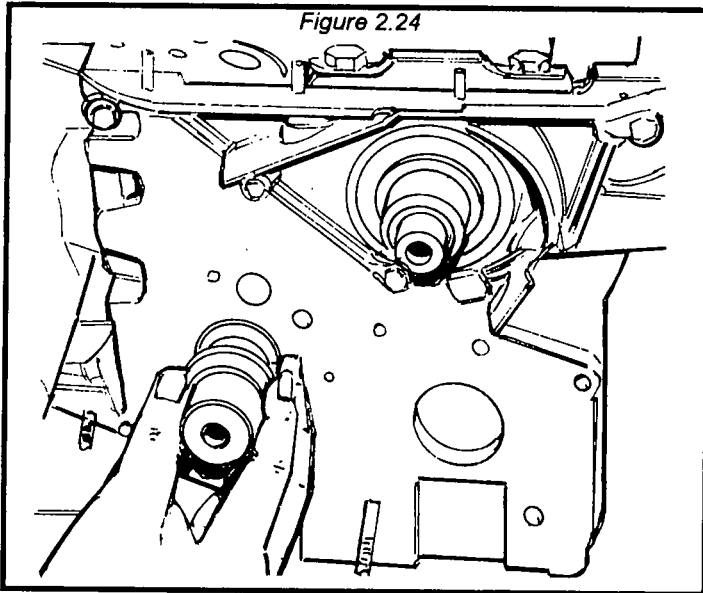

Refitting auxiliary shaft (See Figure 2.24)

Figure 2.25

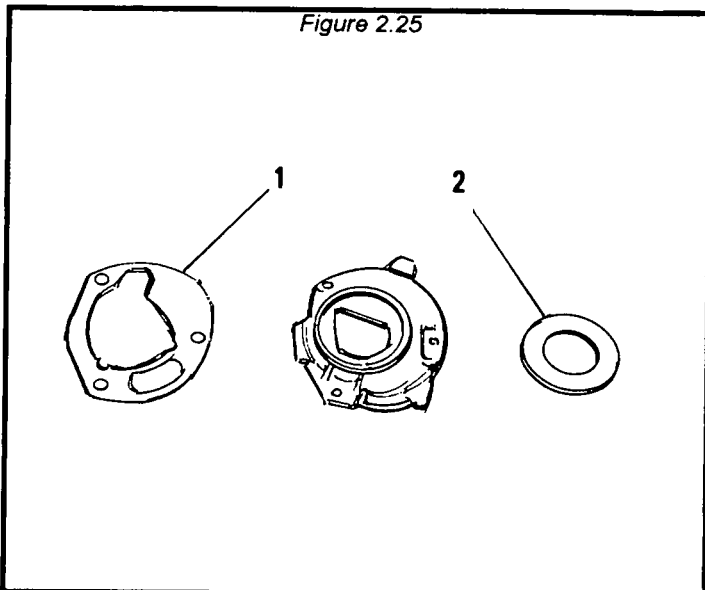

## AUXILIARY SHAFT COVER

Make sure to put a light coating of oil on the lip of the seal (2) and the gasket support surfaces (1). (See Figure 2.25)

# CYLINDER HEAD INSPECTION / REPAIR

Figure 3.4

## Removing camshaft

**NOTE:** Use care when removing the camshaft NOT to mar the camshaft bearing surfaces inside of the camshaft housing. If these surfaces are marred during disassembly, or reassembly replace the housing. (See Figure 3.4)

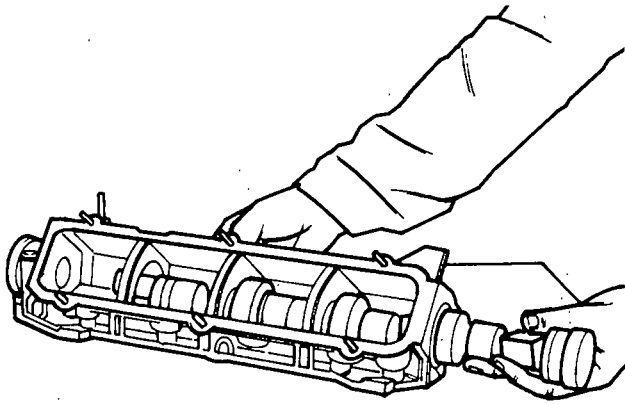

Figure 3.5

## Removing cotter, caps, springs, and valves (See Figure 3.5)

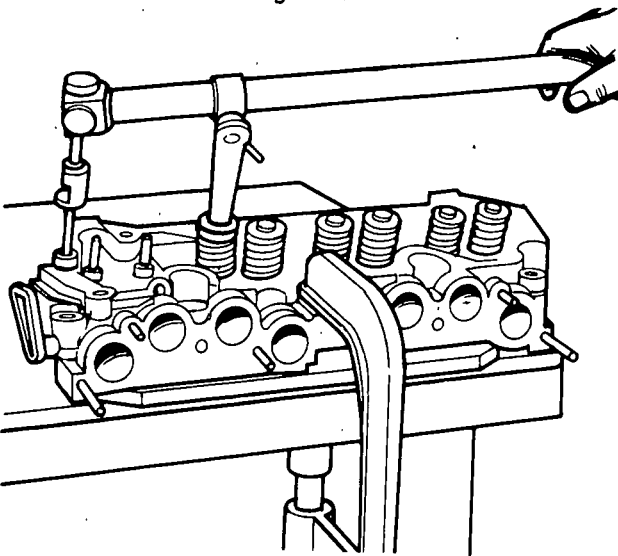
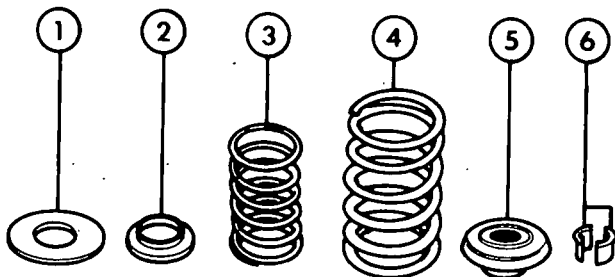

Figure 3.6

## Valve retaining parts

As shown from left to right in Figure 3.6.



1. Flat washer
2. Lower cap
3. Internal spring
4. External spring
5. Upper cap
6. Valve retaining cotten

# CYLINDER HEAD INSPECTION / REPAIR

Figure 3.7

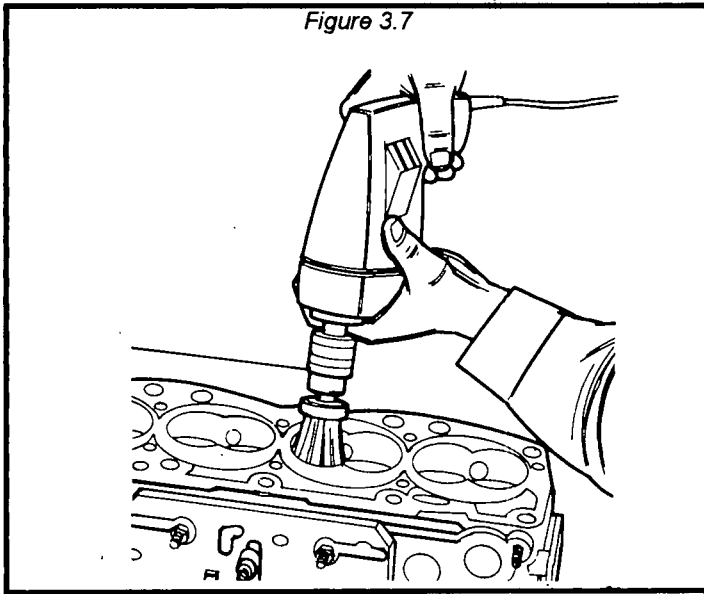

**Decarbonizing and cleaning valve seats and ports (Shown in Figure 3.7)**

**NOTE:** Use **CAUTION** when removing carbon deposits as illustrated as not to damage or mar the valve seats. If the valve seats are marred, they **MUST** be resurfaced or replaced.

Figure 3.8

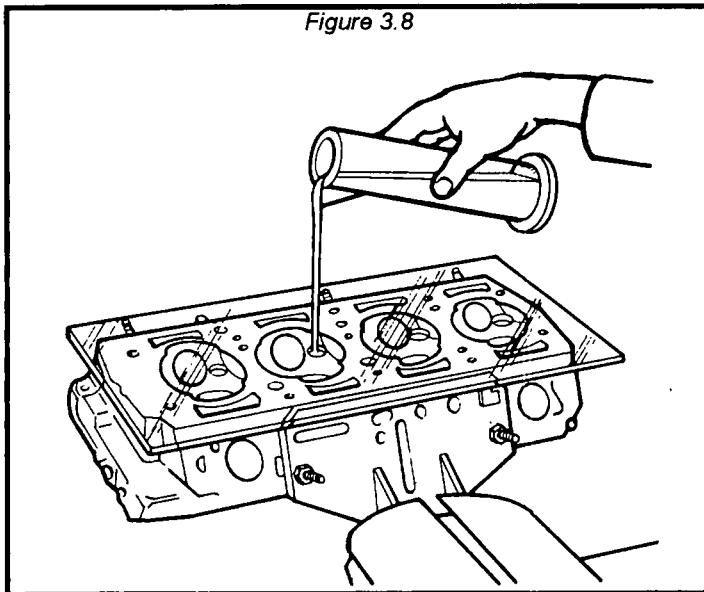

## Combustion chamber depth check

When the cylinder head has been refaced, check the volume of the combustion chamber as described below.

- \* Install the valves and spark plugs.
- \* Fill a graduated test tube with 20 or 30 weight engine oil.
- \* Let the oil settle in the tube for approximately ten minutes.
- \* Make a note of the amount of oil introduced.
- \* Lay a sheet of plexiglass with a small hole by each combustion chamber as illustrated in Figure 3.8.
- \* Completely fill the combustion chamber taking care not to spill any oil beyond the opening.
- \* Allow the oil to settle in the test tube and record the amount of oil dispensed into the combustion chamber.
- \* Repeat the preceding steps on the remaining combustion chambers to assure accuracy between all of the combustion chambers.

Figure 3.9

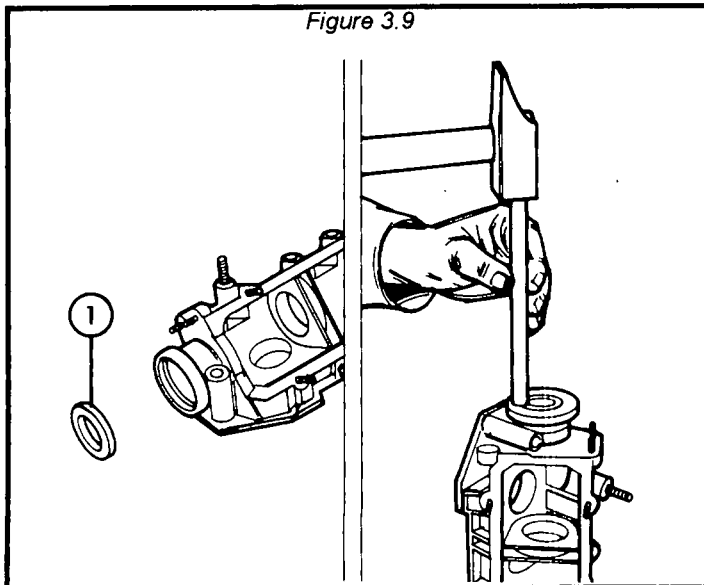

## CAMSHAFT HOUSING

**Fitting the seal on the camshaft housing**  
(See Figure 3.9)

**NOTE:** The camshaft bearing seats show any signs of wear or groove, camshaft housing **MUST** be

# CYLINDER HEAD INSPECTION / REPAIR

Figure 3.10

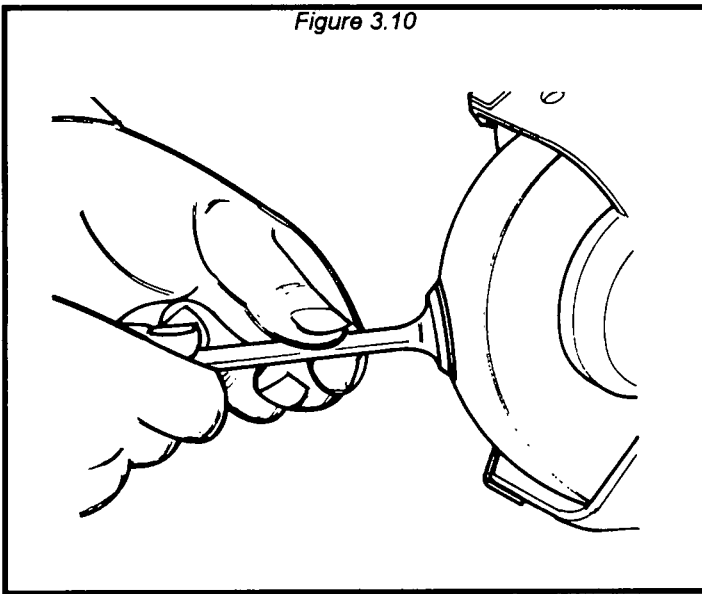

## VALVES

### Decarbonizing and checking the valves

Check that there are no grooves or signs of seizing in the valve stem; also check that the diameter of the valve stem is within the pre-scribed values using a micrometer. (.3158-.3165 in.)

(See Figure 3.10)

Figure 3.11

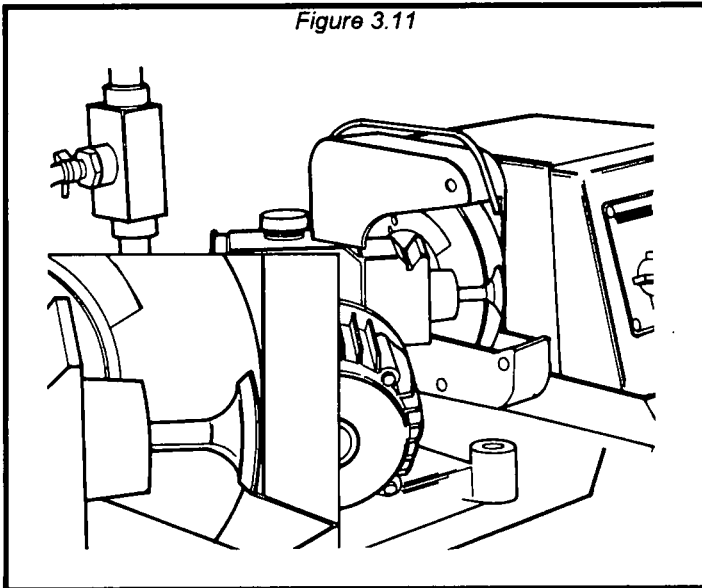

### Refacing a valve using a grinder

The valve face must be cut to 45° (See Figure 3.11) and the valve seat refaced removing as little material as possible.

**NOTE:** Rather than resurface the valve, it is recommended that they be replaced.

Figure 3.12

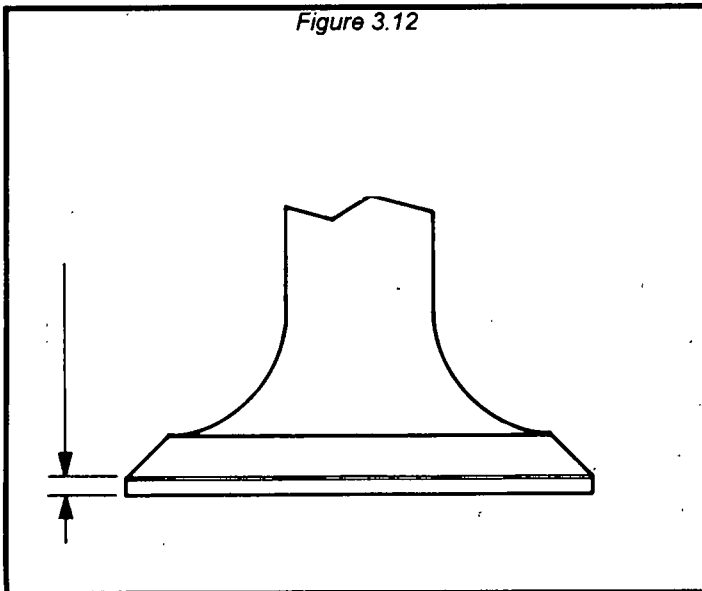

### Checking valve margin

After carrying out the previous operations, check that the margin thickness is no less than (.0393 in.), otherwise the valve must be replaced. (See Figure 3.12)

# CYLINDER HEAD INSPECTION / REPAIR

Figure 3.13

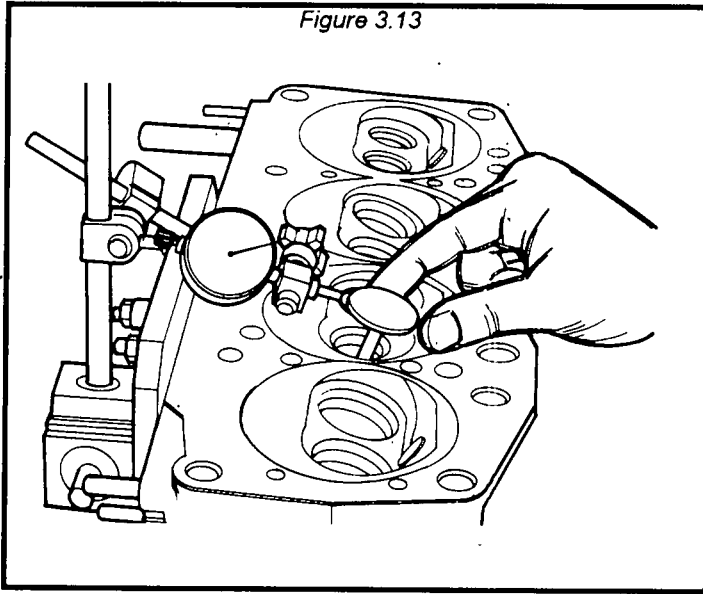

**Checking clearance between valve stem and valve guide**

**NOTE:** If the clearance between the valve stem and valve guide (as measured in Figure 3.13) is greater than (.00984 in.), it is necessary to replace the valve guide.

Figure 3.14

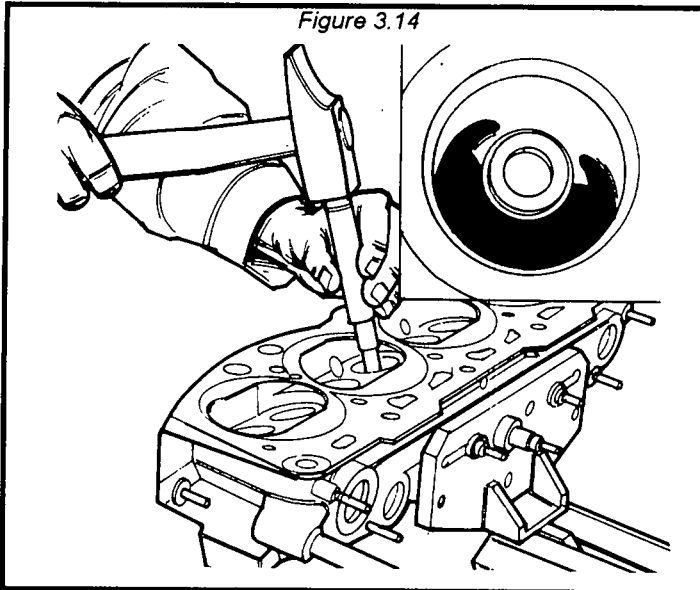

## VALVE GUIDES

Removing valve guides (shown in Figure 3.14)

Figure 3.15

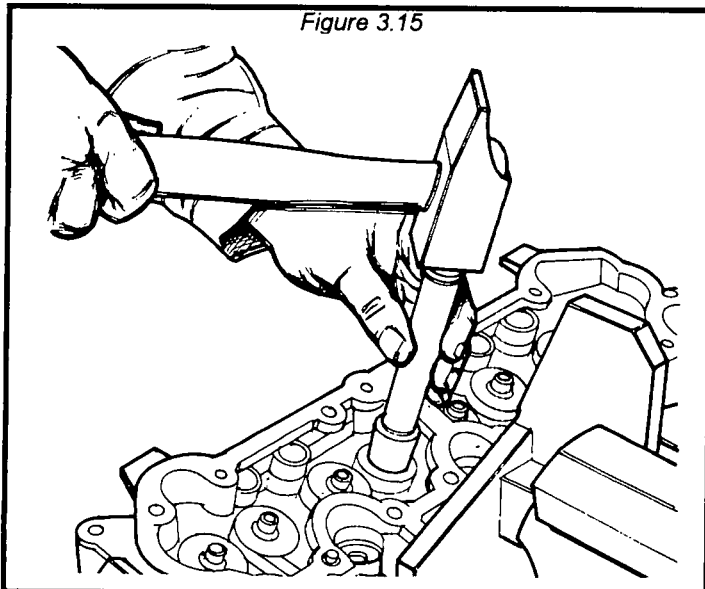

## Refitting the valve guides

Valve guides are available as spares in external diameter oversizes of (.00196-.0039-.0098 in.)

**NOTE:** Before fitting the new valve guides, heat the cylinder head to 100-120° C.

# CYLINDER HEAD INSPECTION / REPAIR

Figure 3.16

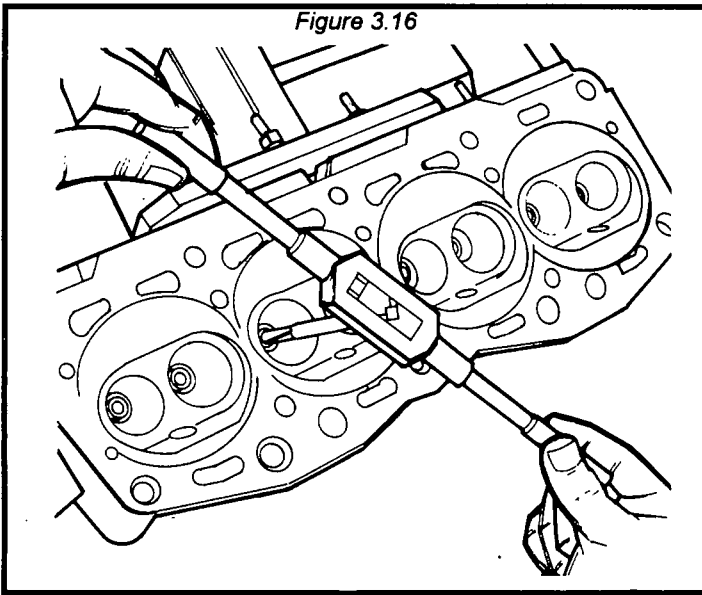

## Reaming valve guide inner surface

This should be carried out to clear the valve guide of any distortions suffered during fitting.  
(See Figure 3.16)

Figure 3.17

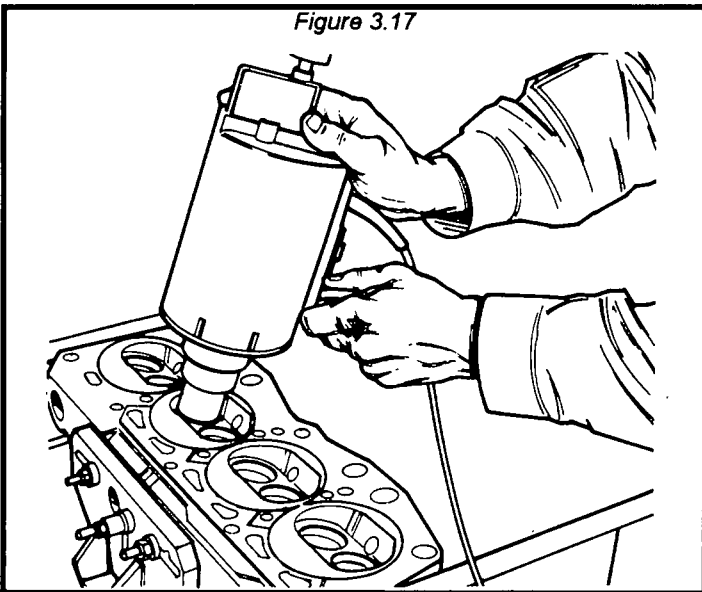

## Refacing valve seats on cylinder head (See Figure 3.17)

**NOTE:** The valve seats are refaced on the cylinder head every time the valves or valve guides are refaced or replaced.

L=Valve seat refaced at 45° and reduced to width described: (See Below)

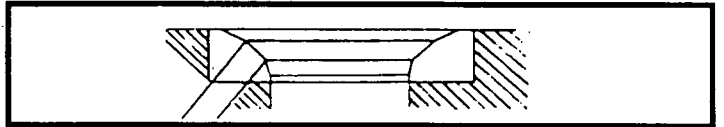

Valve seat grinding with grinder at 44°

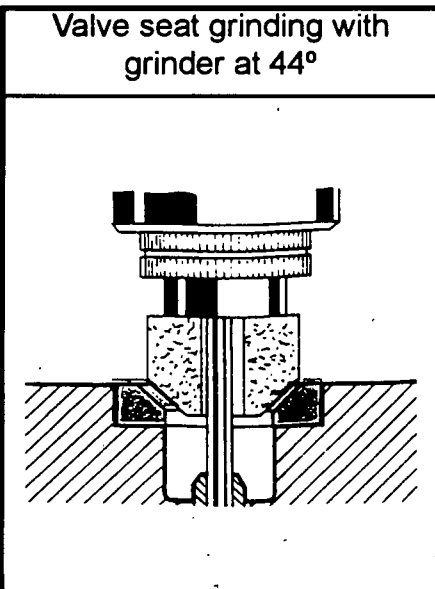

Reducing a valve seat from the top with a grinder at 20°

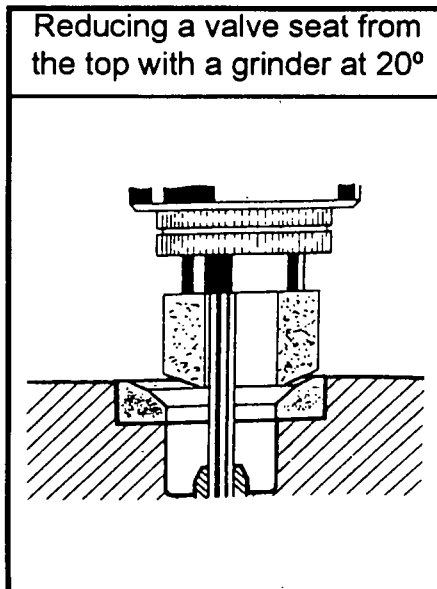

Reducing valve seat from the bottom with a grinder at 75°

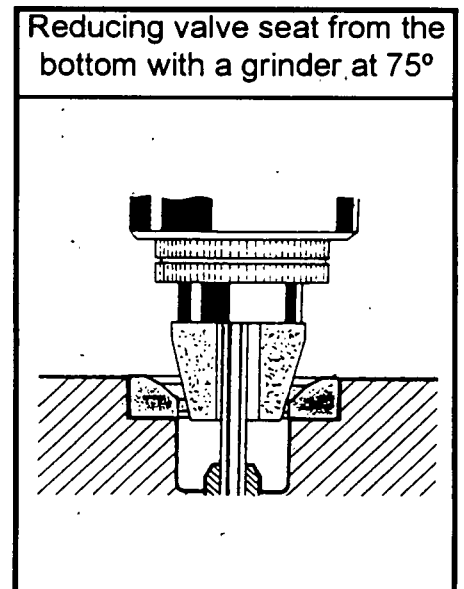

# CYLINDER HEAD INSPECTION / REPAIR

Figure 3.18

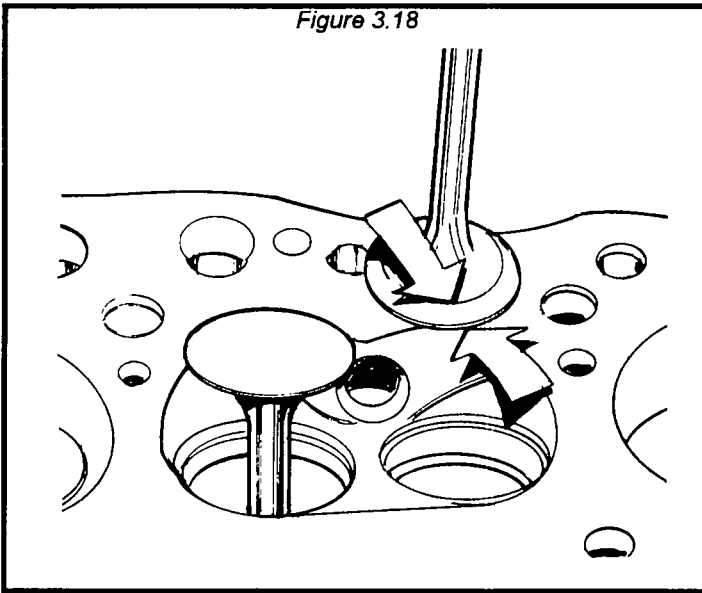

**Checking valve for correct seating**  
(See Figure 3.18)

**NOTE:** If the seating is not well centered, recut the valve seat until this will happen. If this is not possible, replace the valve seat.

Figure 3.19

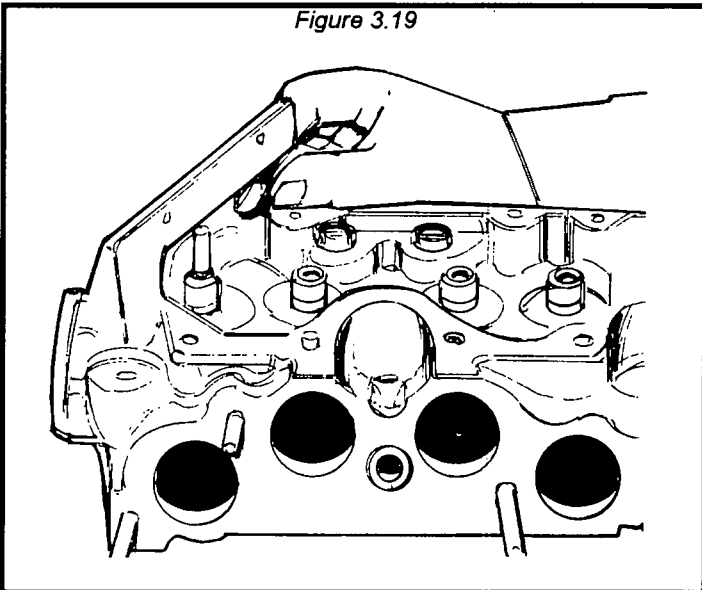

**Checking stem height after facing**  
(See Figure 3.19)

**NOTE:** If the valve stem is too high, shorten the stem by facing. It is recommended to replace the valve rather than grind it.

Figure 3.20

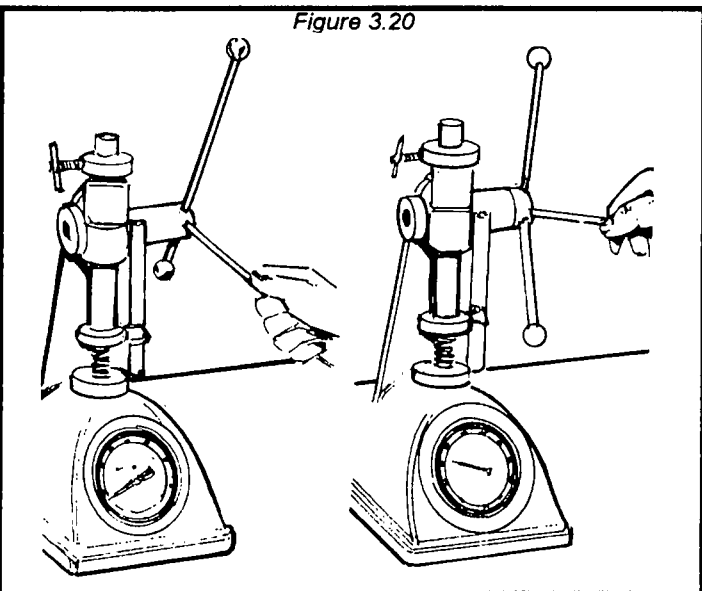

**Valve spring load test**  
(See Figure 3.20)

**NOTE:** Before fitting, the internal and external valve springs must be checked to ensure that the minimum loads are within the prescribed values

Inner valve spring:	
Description	Rating
Seat pressure	31.7-33.9 lb.
Free height	1.2204 in.
Pressure at lift	59.3-64.5 lb.
Installed height	.8464 in.
Outer valve spring:	
Seat pressure	82.5-89.0 lb.
Free height	1.4173 in.
Pressure at lift	125.6-136.6 lb.
Installed height	1.0433 in.

# CYLINDER HEAD INSPECTION / REPAIR

Figure 3.21

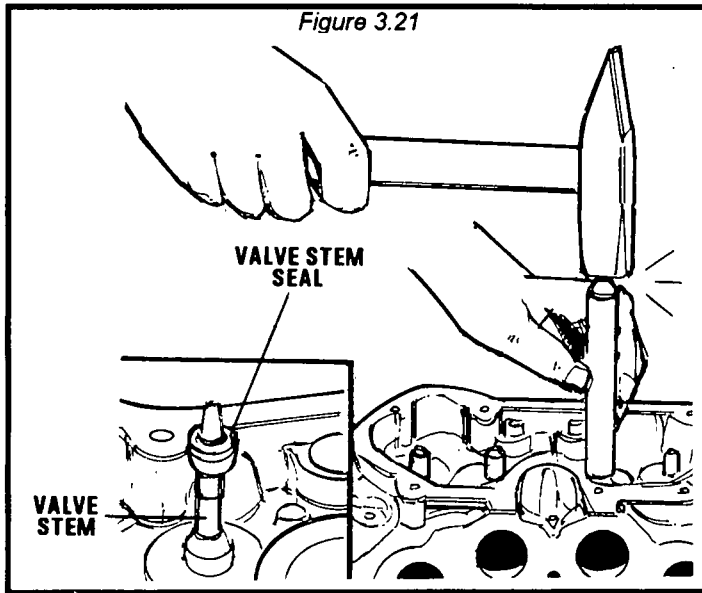

**Fitting oil seals on valve guides**  
(See Figure 3.21)

**NOTE:** Oil all concerned parts before assembly.

Figure 3.22

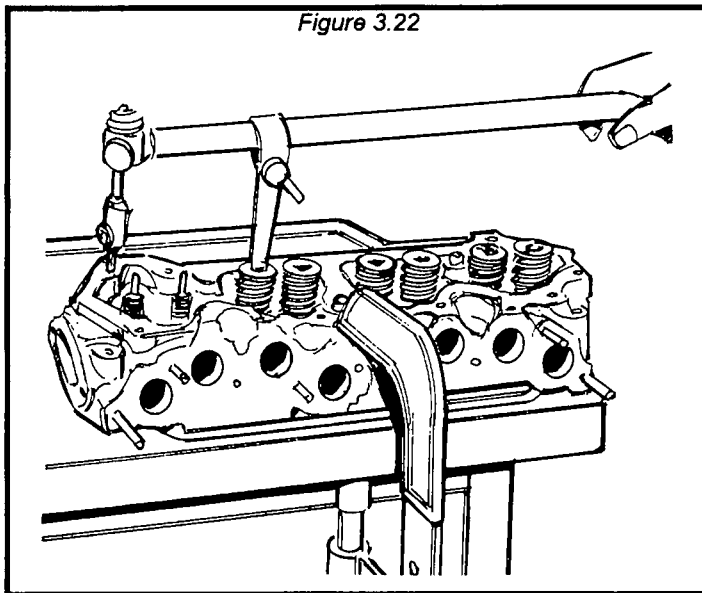

**Fitting valves, caps, springs and cotters**  
(See Figure 3.22)

**NOTE:** Be sure that the valve springs and keepers are fully seated before completing cylinder head assembly.

Figure 3.23

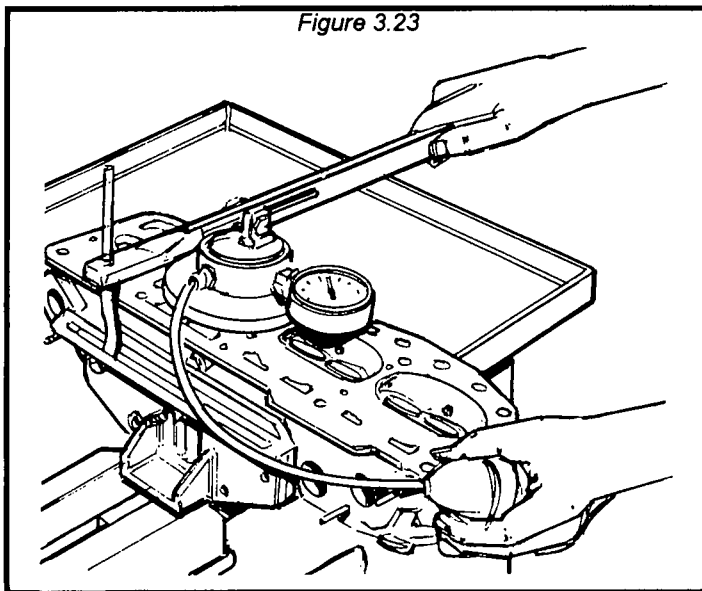

**Valve leakage test**

The valve leakage test is performed as a procedure to assure that the valves are sealed.

**NOTE:** This test should be carried out with spark plugs fitted.

# CYLINDER HEAD INSPECTION / REPAIR

Figure 3.24

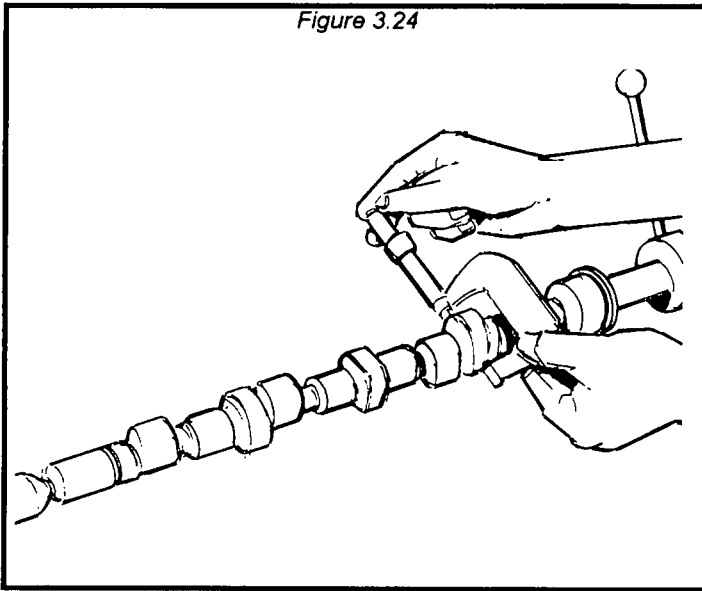

## CAMSHAFT

**Measuring camshaft bearing surfaces**  
(See Figure 3.24)

Surface #1. (1.1789-1.1795 in.)

Surface #2. (1.8872-1.8878 in.)

Surface #3. (1.8951-1.8957 in.)

Surface #4. (1.9029-1.9035 in.)

Surface #5. (1.9108-1.9114 in.)

**NOTE:** The surfaces of the cams and the bearings must not show any traces of seizing or grooves or else the camshaft must be replaced.

Figure 3.25

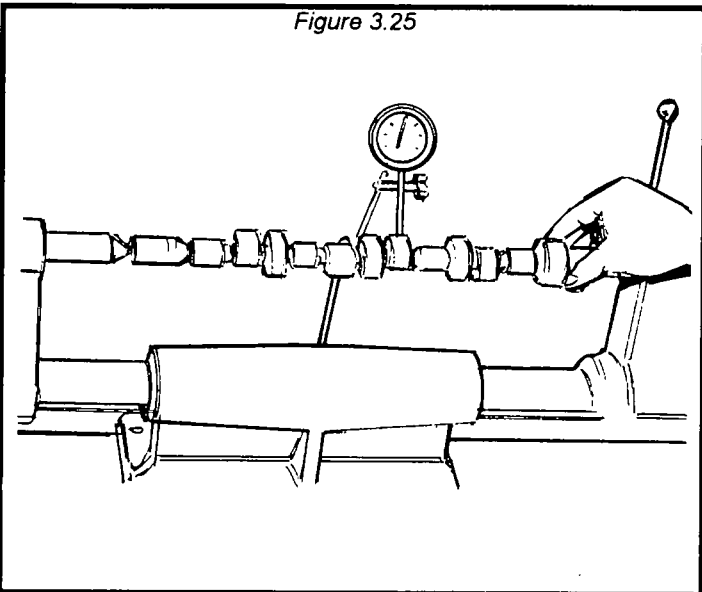

## Cam lift measurement

(Camshaft lift .346 in.) (See Figure 3.25)

**NOTE:** Excess wear of even one single cam lobe means that the camshaft must be replaced.

Figure 3.26

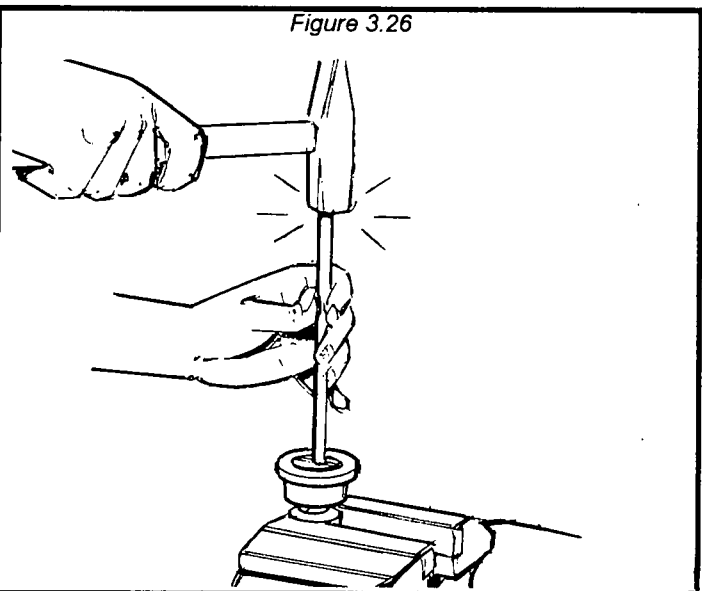

**Fitting plug on camshaft end** (As shown in Figure 3.26)

# CYLINDER HEAD INSPECTION / REPAIR

Figure 3.27

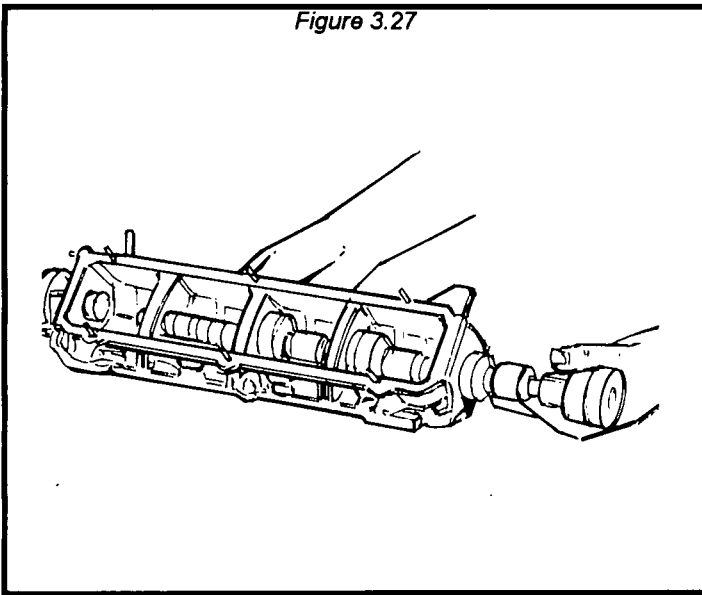

**Fitting camshaft in camshaft housing**  
(See Figure 3.27)

**NOTE:** Use extreme care not to mar the bearing surfaces of the camshaft housing. If this is done, the camshaft housing must be replaced.

Figure 3.28

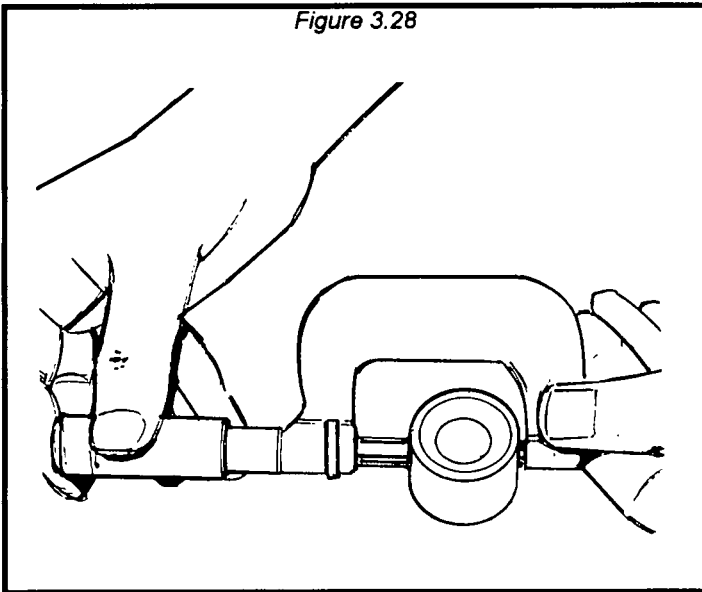

**Checking tappet diameter**

Using a micrometer, (as shown in Figure 3.28) measure the tappets. If there is excessive ovality, the tappet must be replaced. Desired diameter is between (1.4566-1.4576 in.)

Figure 3.29

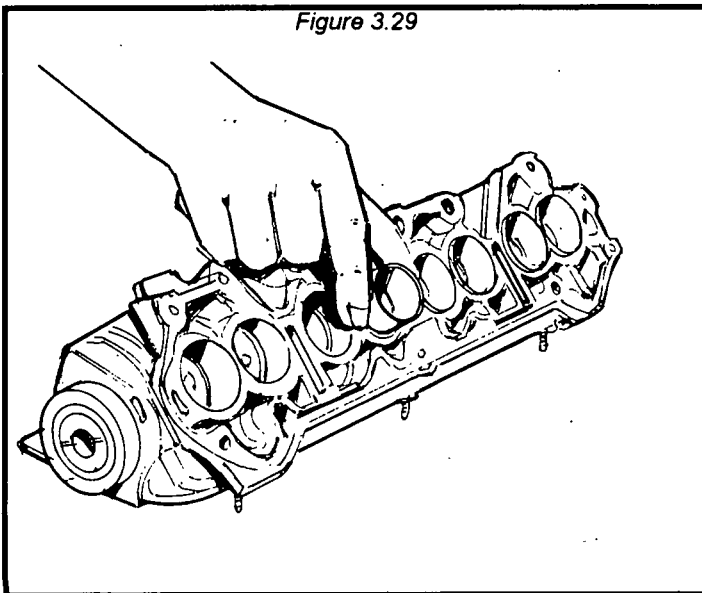

**Checking housings and fitting tappets**

If the tappet housings are extremely worn, replace the camshaft housing.

**NOTE:** Oil all concerned parts before assembly.

# CYLINDER HEAD INSPECTION / REPAIR

Figure 3.30

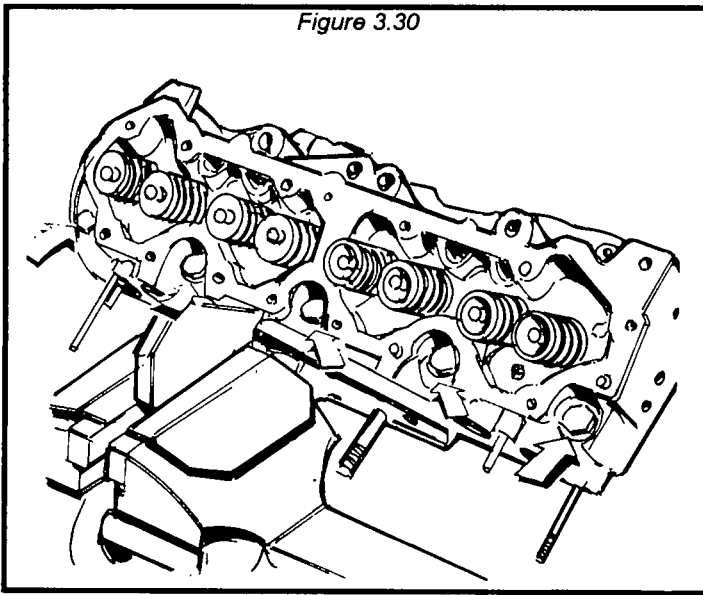

## REFITTING CYLINDER HEAD

### Cylinder head

The arrows show the cylinder head fixing bolts (manifold side) which must be positioned in their housings before fitting the camshaft housing. (See Figure 3.30)

Figure 3.31

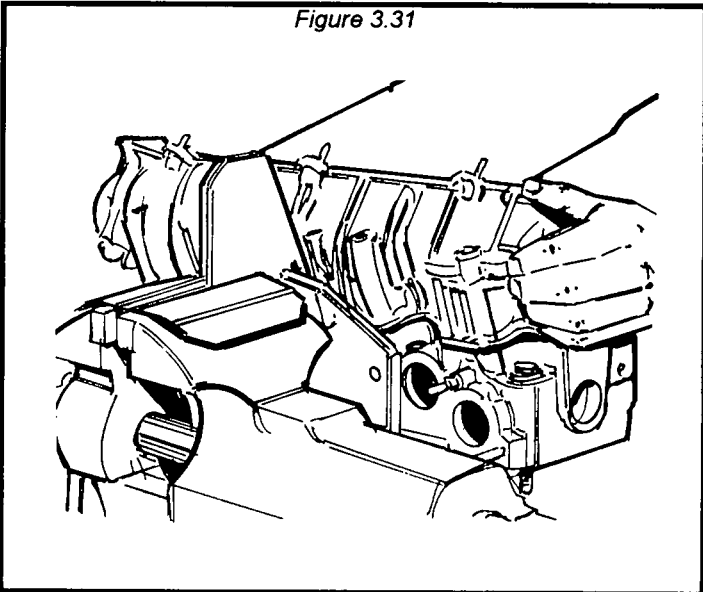

## Refitting camshaft housing on cylinder head

(See Figure 3.31)

Figure 3.32

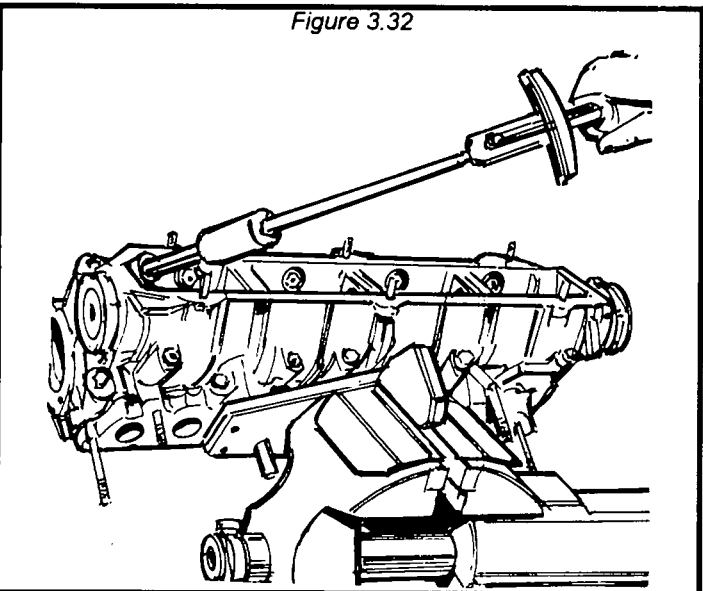

## Tightening upper cylinder head bolts

Start by tightening the center bolts and work your way to the outer bolts as shown in Figure 3.32.

(M8 bolts: 22 ft-lb.)

(M10 bolts: 29.5 ft-lb.)

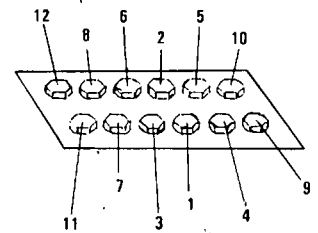

# CYLINDER HEAD INSPECTION / REPAIR

Figure 3.33

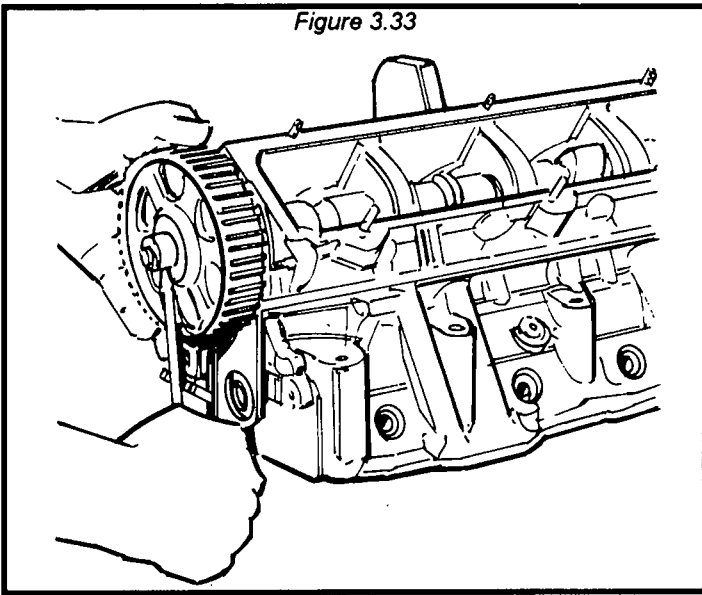

**Temporary fitting of camshaft pulley**  
(See Figure 3.33)

**NOTE:** When the tappets have been adjusted, remove the camshaft pulley.

Figure 3.34

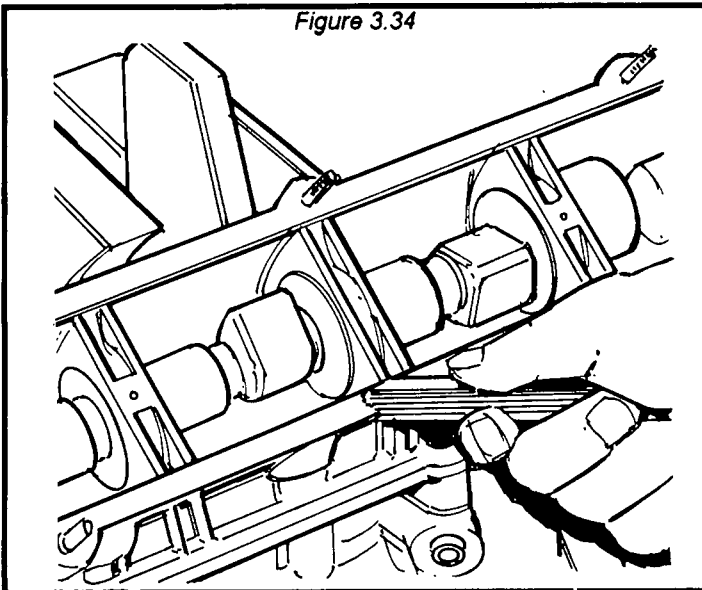

**Checking clearance between valves and cylinder head at the bench**

Rotate the camshaft until the cam is perpendicular (upwards) to the tappet shim to be checked; then take the measurement. (0.315 in. cold)  
(See Figure 3.34)

Figure 3.35

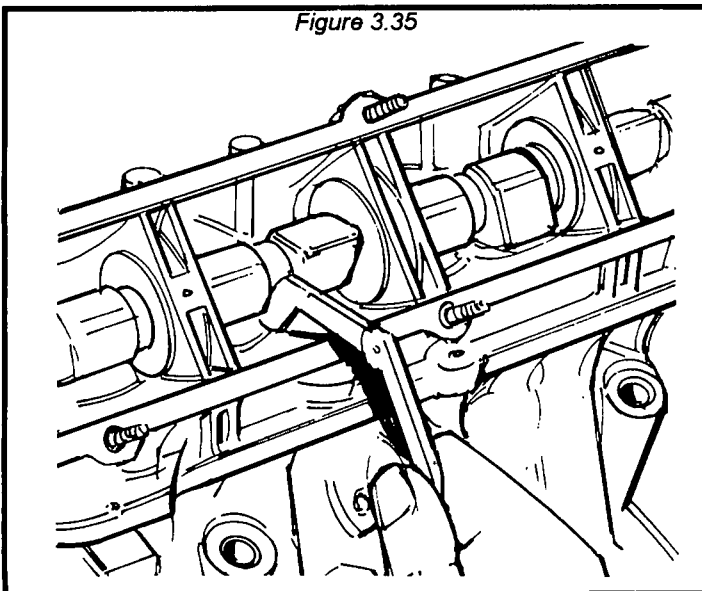

**View of typical tappet retaining tool**  
(See Figure 3.35)

# CYLINDER HEAD INSPECTION / REPAIR

Figure 3.36

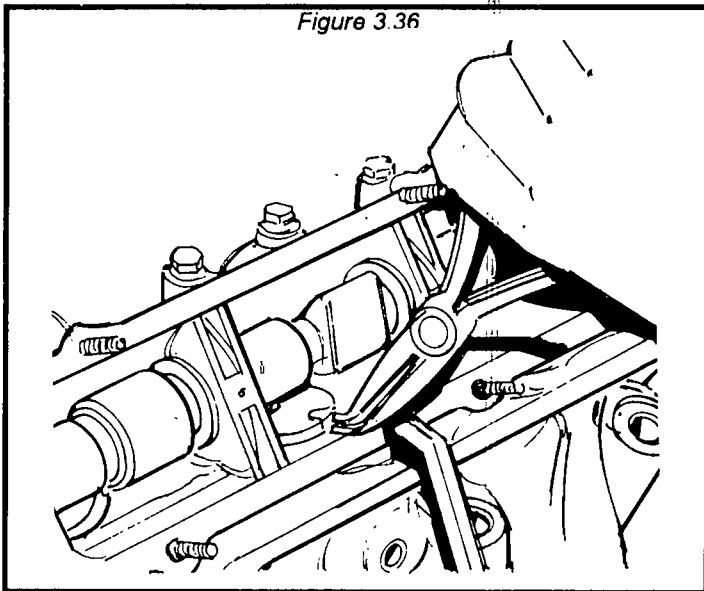

Removing tappet adjustment shim using pliers. (See Figure 3.36)

**NOTE:** Replace the shim removed with another of the same size to restore the correct valve clearance. Carry out the same operation for the other shim of the pair of valves being adjusted.

Figure 3.37

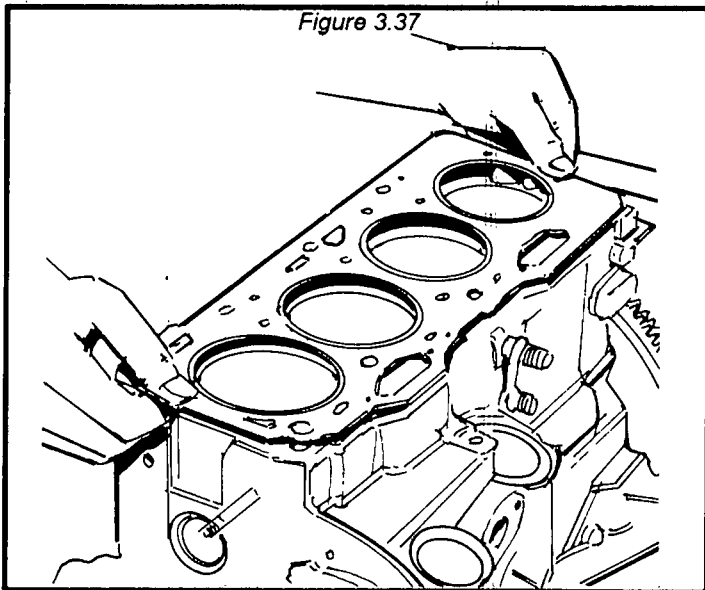

Refitting the cylinder head gasket  
(As shown in Figure 3.37)

**NOTE:** Position the head gasket on the cylinder block with the word "ALTO" facing the operator. "Permanent Torque" type cylinder head gaskets have been fitted. These gaskets, on account of the special material from which they are made, undergo a sealing process during the operation of the engine.

Figure 3.38

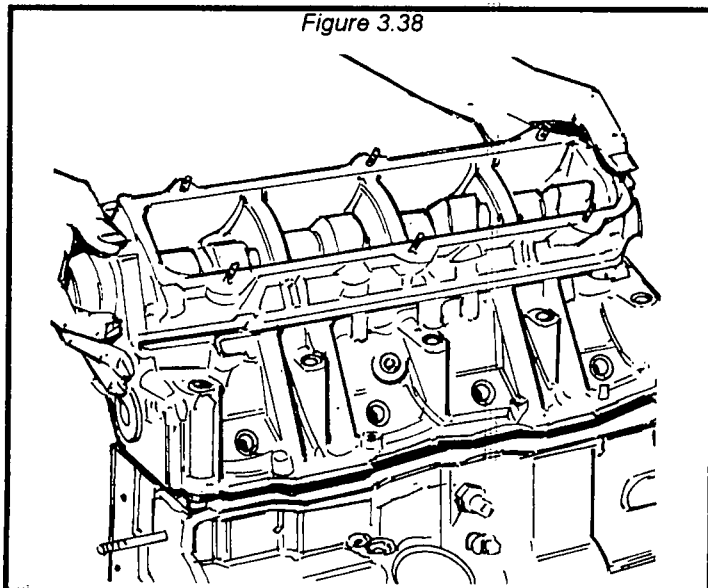

Fitting cylinder head  
(See Figure 3.38)

**NOTE:** In order to ensure that the sealing process takes place, it is necessary to:

- \* Keep the gaskets in their original, sealed packages.

- \* Only remove them shortly before fitting.

- \* Avoid any oil or grease coming into contact with the gasket and take care that the surfaces of the cylinder head and block are clean.

# CYLINDER HEAD INSPECTION / REPAIR

Figure 3.39

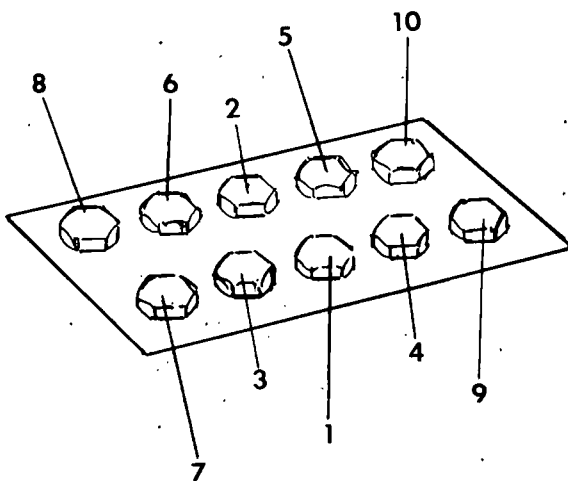

## CYLINDER HEAD TIGHTENING

### Diagram showing tightening order

The procedure for correctly tightening the cylinder head bolts is as follows: (See Figure 3.39)

**NOTE:** Lubricate the bolts and washers lightly before assembly.

Figure 3.40

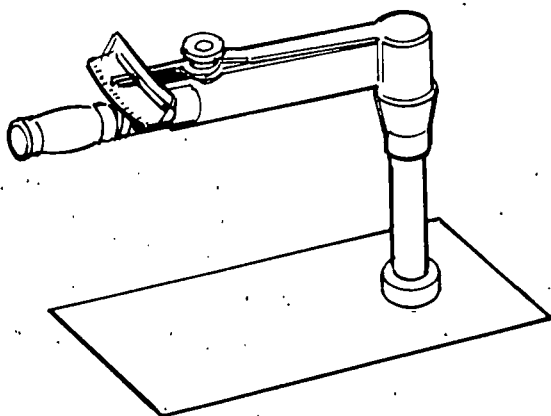

### Pre-tightening cylinder head bolts using a torque wrench in two stages

\*Tighten the bolts to a torque of 15 ft-lb.

\*Tighten the bolts using a torque wrench to a torque of 30 ft-lb.

Figure 3.41

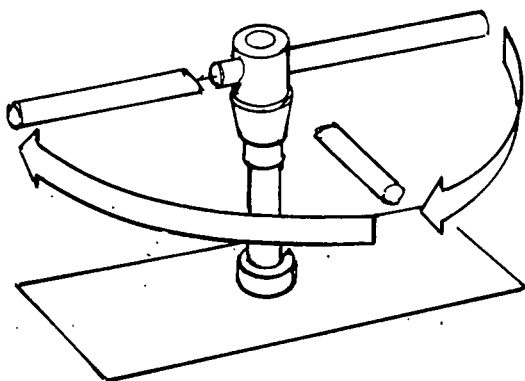

### Tighten the cylinder head bolts in two stages of 90° increments.

(M8 bolts: 22 ft-lb, M10 bolts: 29.5 ft-lb.)

Using an ordinary spanner, further tighten the bolts through 180° in two stages of 90° increments following the order given.

**NOTE:** Where "Permanent Torque" gaskets are fitted, it is no longer necessary to retighten the cylinder head bolts after the break in period.

# CYLINDER HEAD INSPECTION / REPAIR

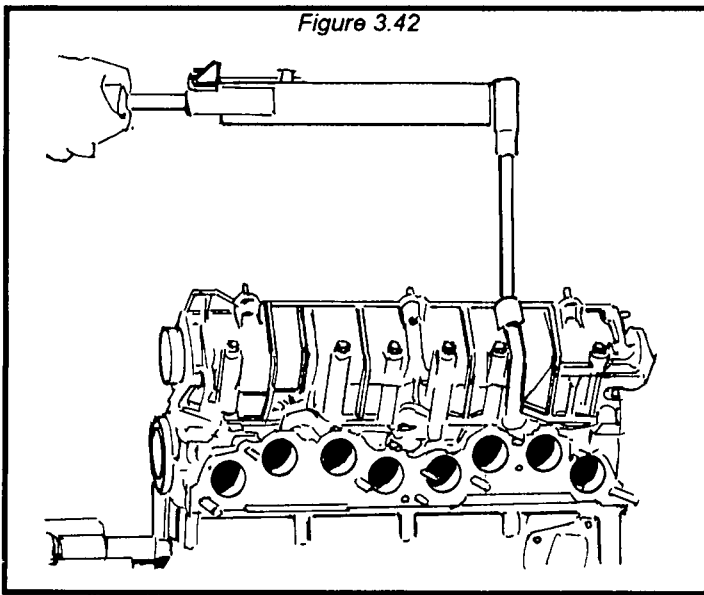

**Tightening cylinder head bolts using a torque wrench (Manifold side)**

(See Figure 3.42)

(M8 bolts: 22 ft-lb, M10 bolts: 29.5 ft-lb + 90° + 90°).

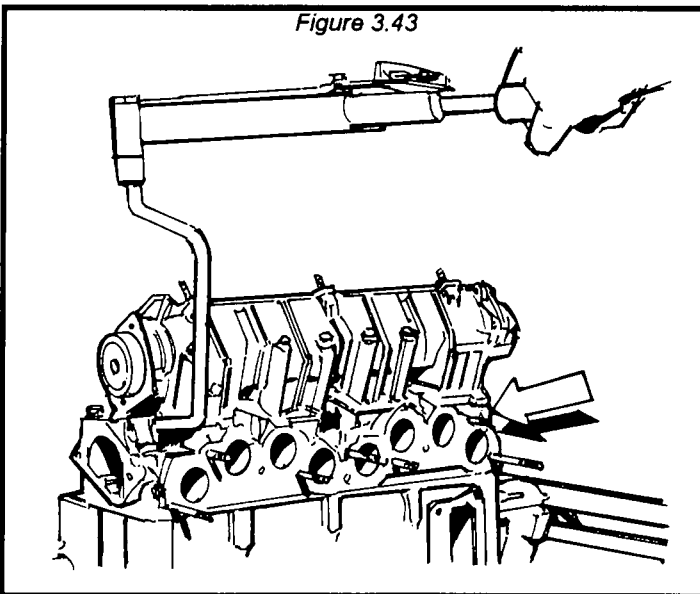

**tightening cylinder head side fixing bolts using a torque wrench (Manifold side)**

(See Figure 3.43)

(M8 bolts: 22 ft-lb, M10 bolts: 29.5 ft-lb + 90° + 90°).

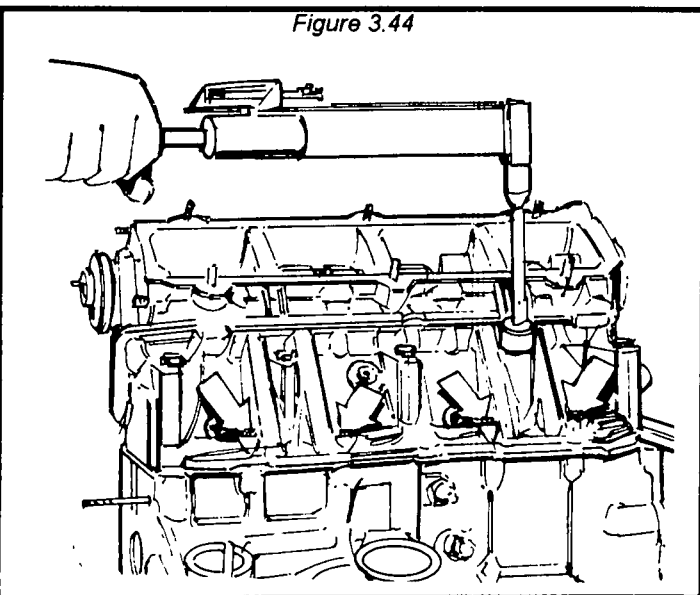

**Tightening cylinder head fixing bolts (Spark plug side) using a torque wrench**

“Permanent Torque” gaskets are fitted in conjunction with yield point type cylinder head bolts. These bolts are replaced after they have been used four (4) times.

**NOTE:** When the cylinder head has been tightened, tighten the bolts shown by the arrows in Figure 3.44 to a torque of 15 ft-lb.

# VALVE TIMING

Figure 4.1

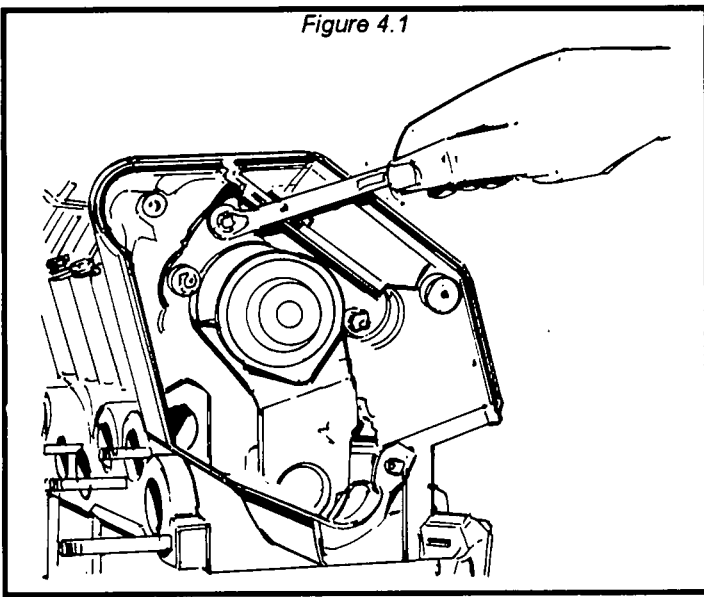

## REFITTING TIMING SYSTEM COMPONENTS

### Fitting timing upper casing

The arrows in Figure 4.1 show the fixing nuts to be tightened.

Figure 4.2

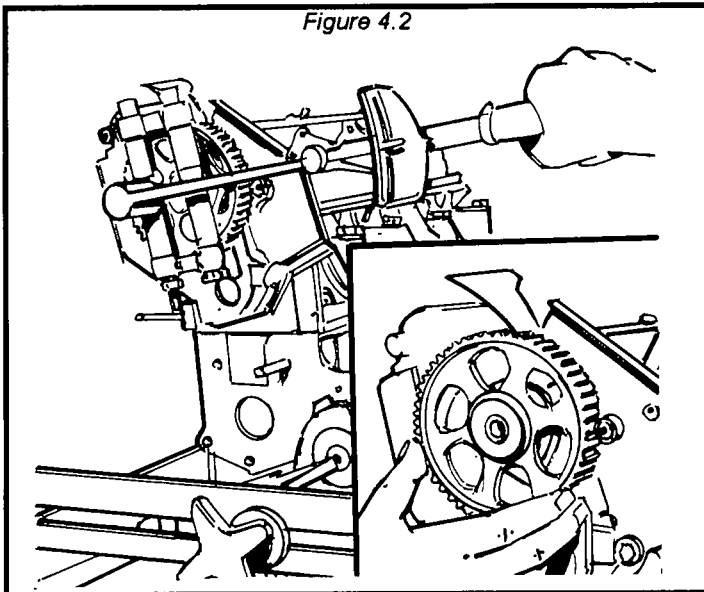

Fitting camshaft pulley and tightening fixing bolt to 62 ft-lb torque. (See Figure 4.2)

Figure 4.3

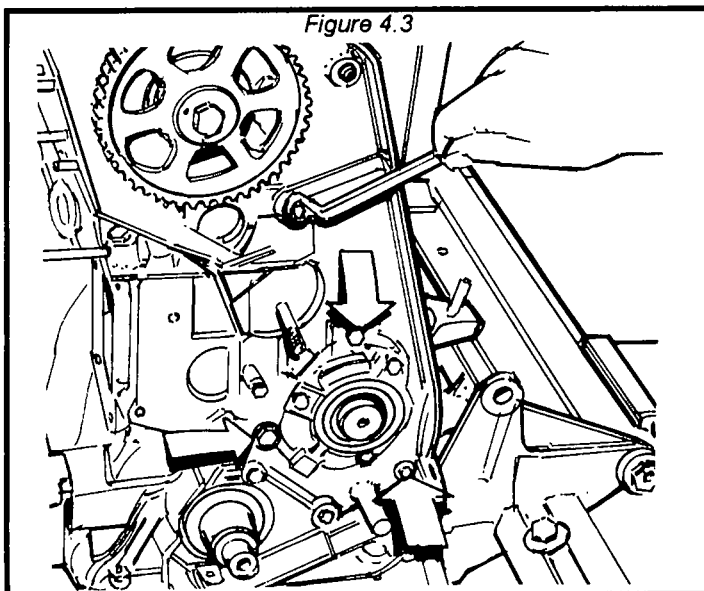

### Fitting timing lower casing

The arrows show the fixing bolts. tighten to (18.5 ft-lb.) (See Figure 4.3)

# VALVE TIMING

Figure 4.4

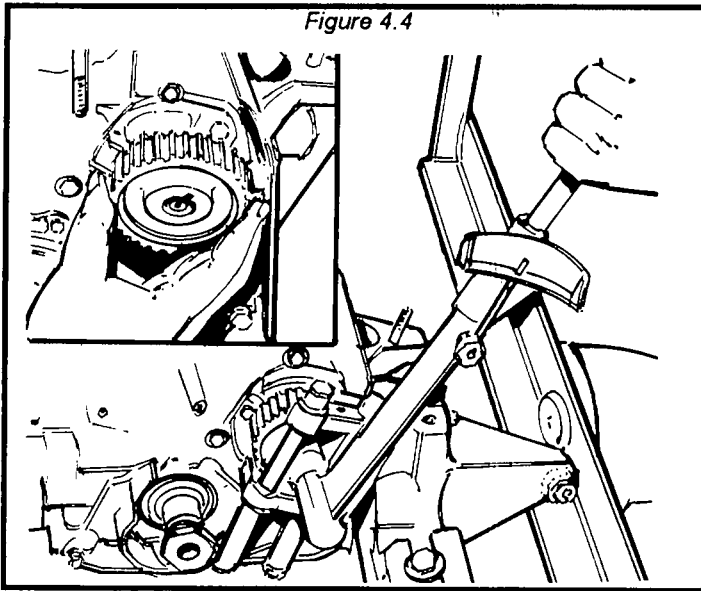

**Fitting auxiliary shaft pulley and bolt to torque (62 ft-lb).**  
(See Figure 4.4)

Figure 4.5

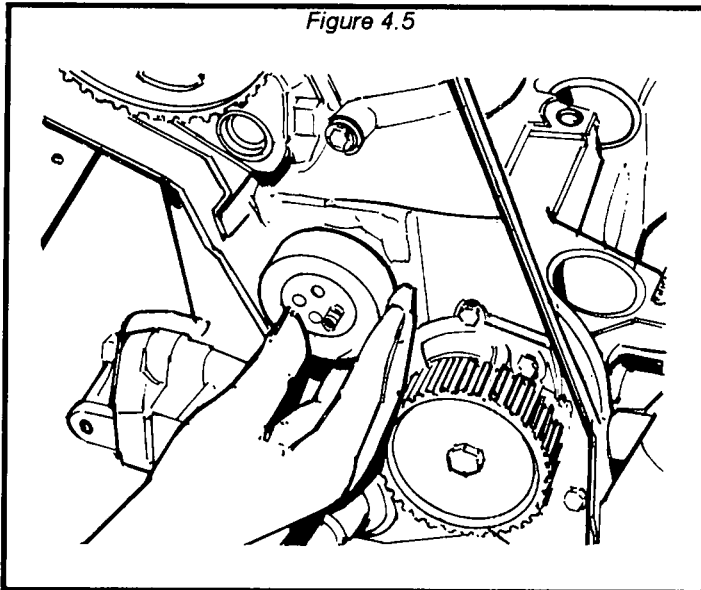

## **Fitting belt tensioner**

Temporarily tighten the belt tensioner fixing nut as shown in Figure 4.5 to a torque of **16 ft-lb**.

Figure 4.6

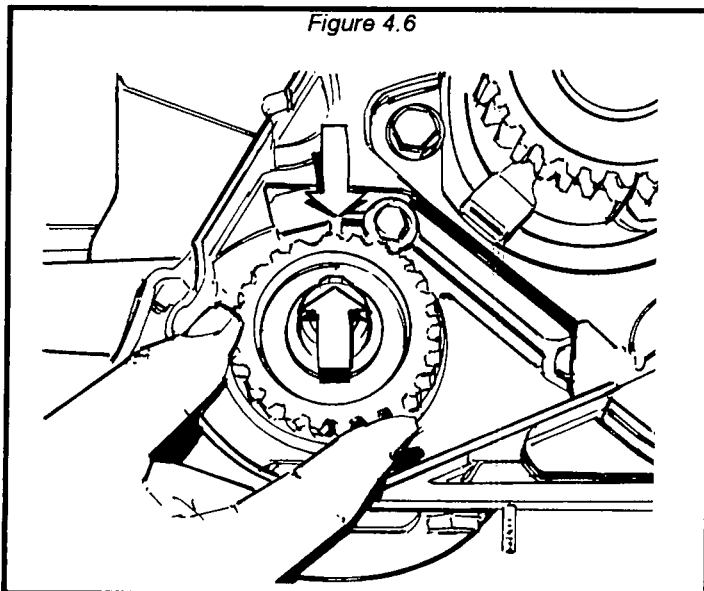

## **TIMING AND FITTING TIMING BELT**

### **Fitting timing drive gear**

Rotate the crankshaft so that the spline in the timing gear is in line with the reference mark on the cover as shown in Figure 4.6.

# VALVE TIMING

Figure 4.7

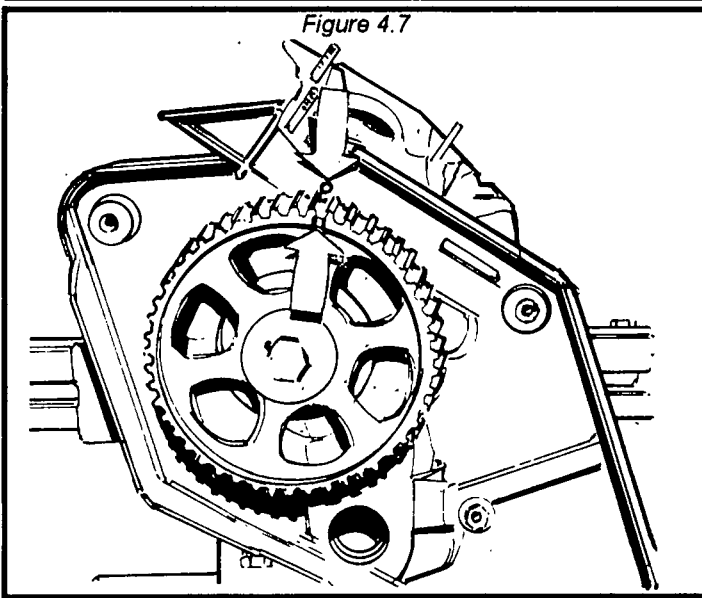

## Positioning the camshaft

Rotate the camshaft so that the reference mark on the pulley is aligned with the fixed reference mark on the upper casing. (See Figure 4.7)

Figure 4.8

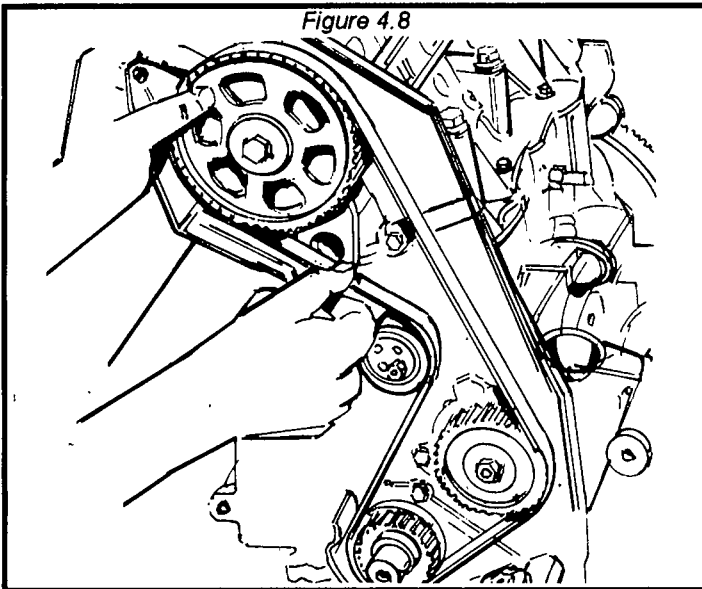

## Fitting timing belt

(See Figure 4.8)

**NOTE:** Visually inspect the timing belt every annual tune up and replace immediately if it is:

- \* Soaked with oil or coolant
- \* Has cranked or broken teeth
- \* Has loose threads or worn teeth

The belt must be replaced if it has to be removed.

Figure 4.9

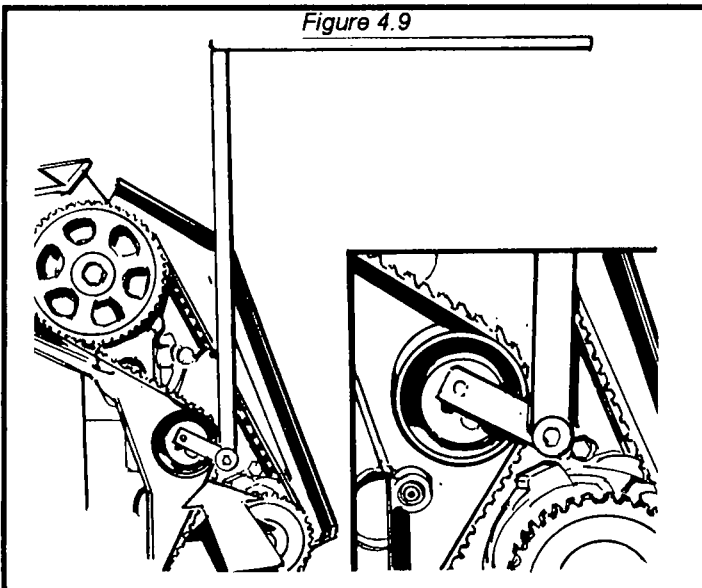

## Setting timing belt tension

Fit a belt tension tool on the belt tensioner as shown in Figure 4.9. Rotate the crankshaft two revolutions in it's direction of rotation and then lock the belt tensioner.

# VALVE TIMING

Figure 4.10

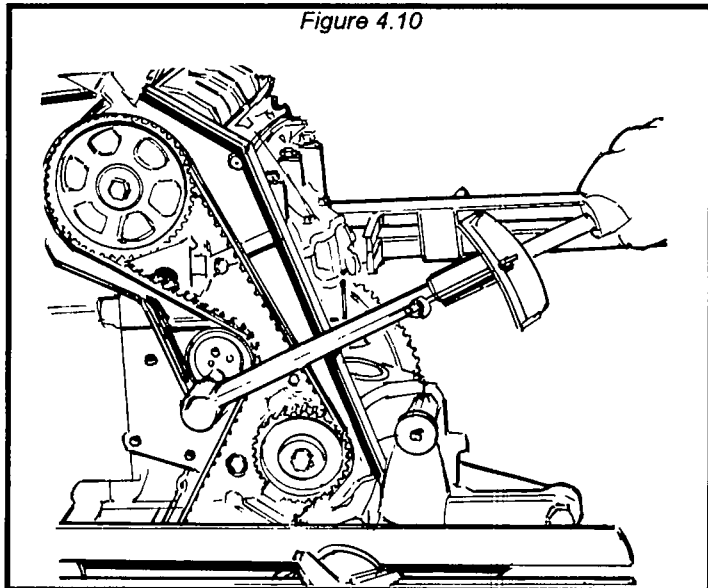

**Tightening belt tensioner fixing nut to torque (32.5 ft-lb) (See Figure 4.10)**

Figure 4.11

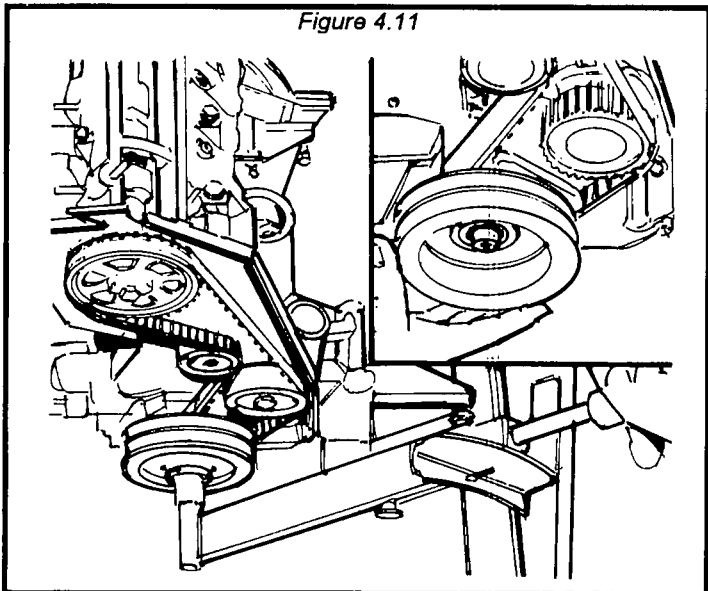

## REFITTING TIMING SYSTEM

**Fitting crankshaft pulley and tightening fixing bolt to torque (101 ft-lb)**

**NOTE:** In order to tighten the crankshaft pulley fixing bolt to torque, use a flywheel locking device.

Figure 4.12

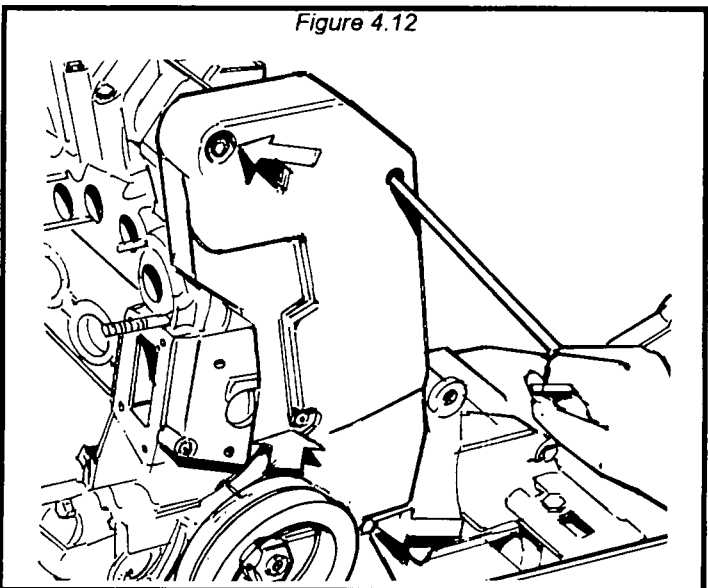

**Fitting timing cover (See Figure 4.12)**

## VALVE TIMING

Figure 4.13

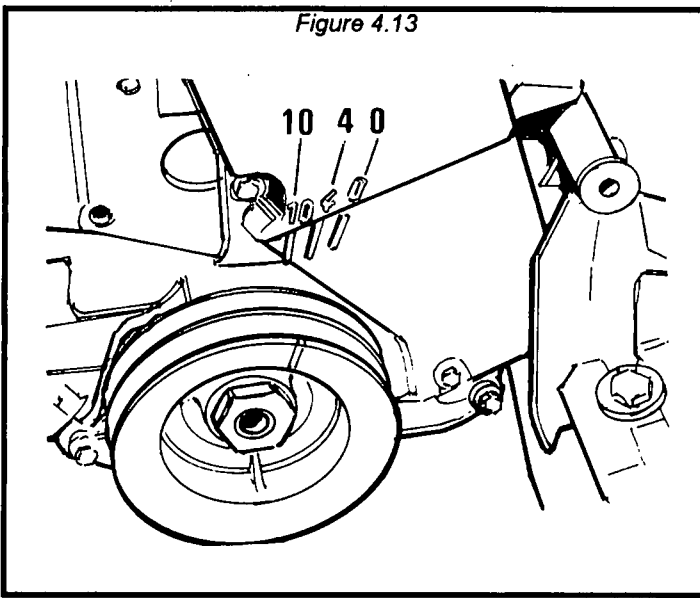

### Positioning crankshaft

Before final reassembly of the engine at the bench, rotate the crankshaft so that the reference mark on the crankshaft pulley is in line with the 0° reference mark on the timing belt shield cover; in this position piston nos. 1 and 4 are at TDC.

**NOTE:** If the timing has to be set with the engine running, the crankshaft should be positioned at TDC using the reference marks on the flywheel and the bell housing inspection window, respectively.

# ENGINE REASSEMBLY

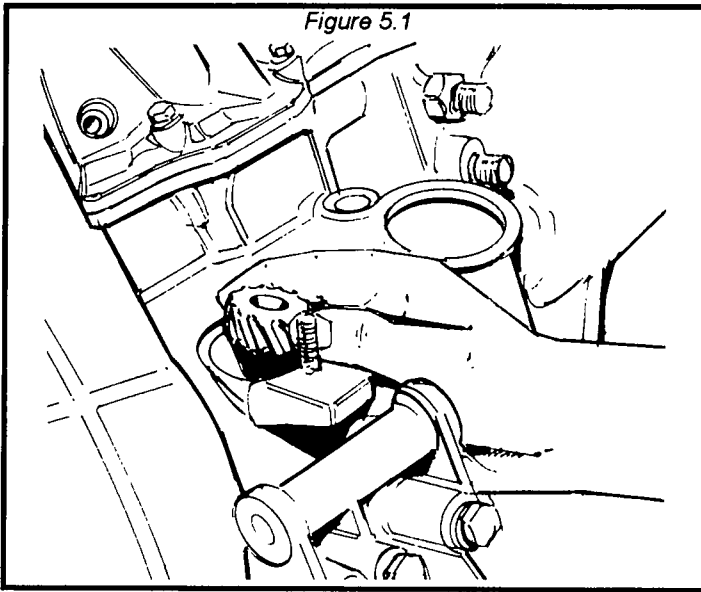

**REFITTING VARIOUS COMPONENTS**  
**Refitting oil pump drive gear**  
(See Figure 5.1)

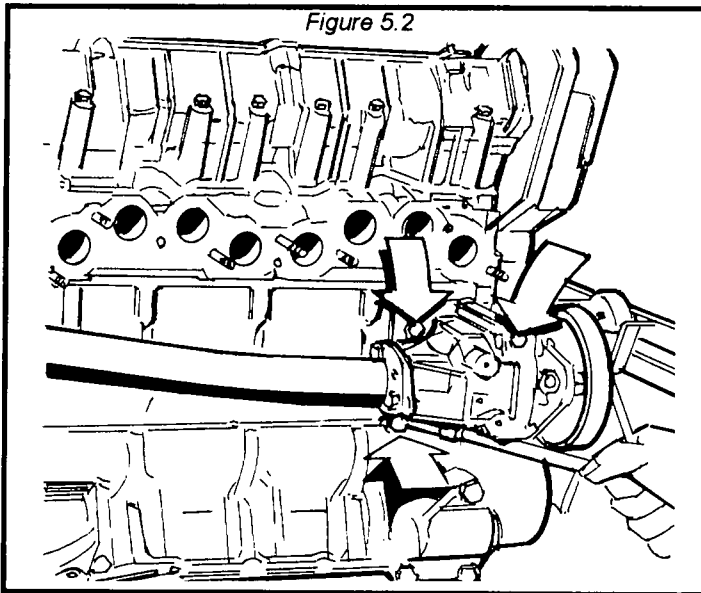

**Refitting water pump and pipes**  
(See Figure 5.2)

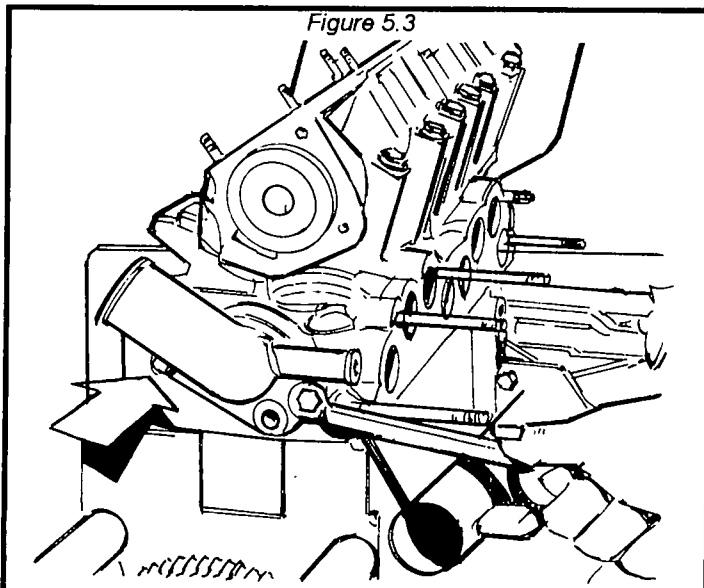

**Refitting thermostat on cylinder head**  
(See Figure 5.3)

# ENGINE REASSEMBLY

Figure 5.4

**Refitting the intake manifold, torque to 20.5 ft-lb.**

The arrows in Figure 5.4 show the fixing nuts.

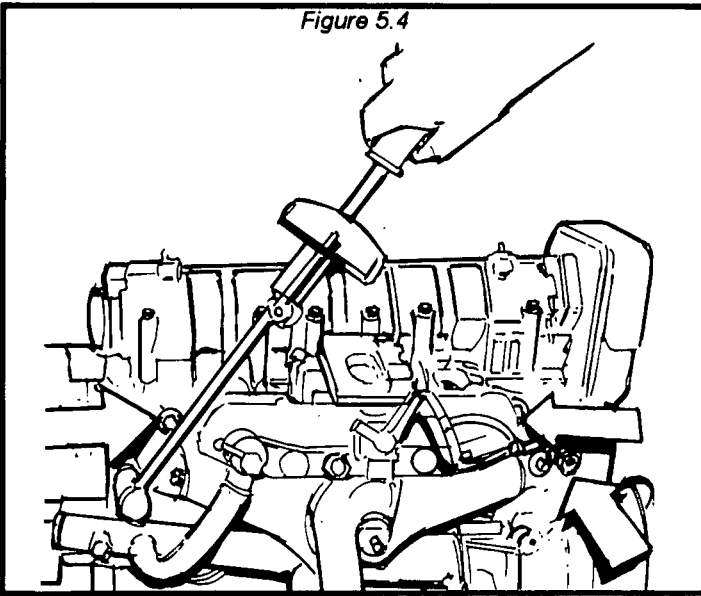

Figure 5.5

**Refitting the exhaust manifold**

Tighten nuts to 20.5 ft-lb. (See Figure 5.5)

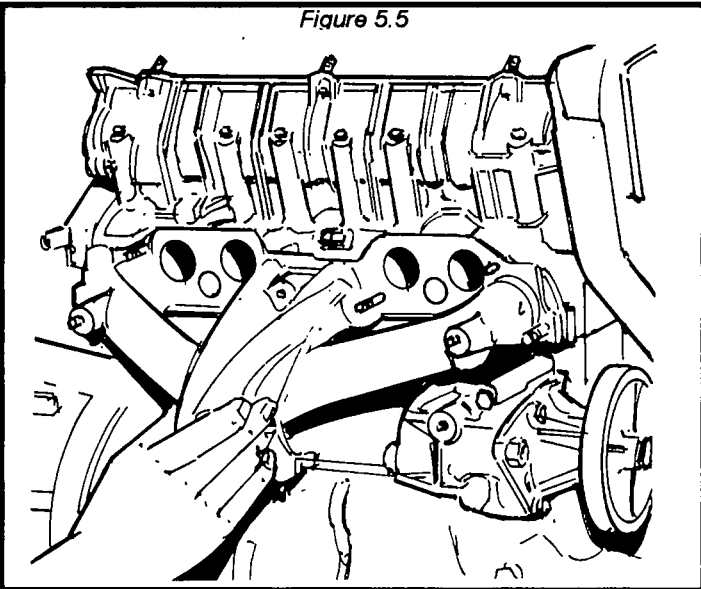
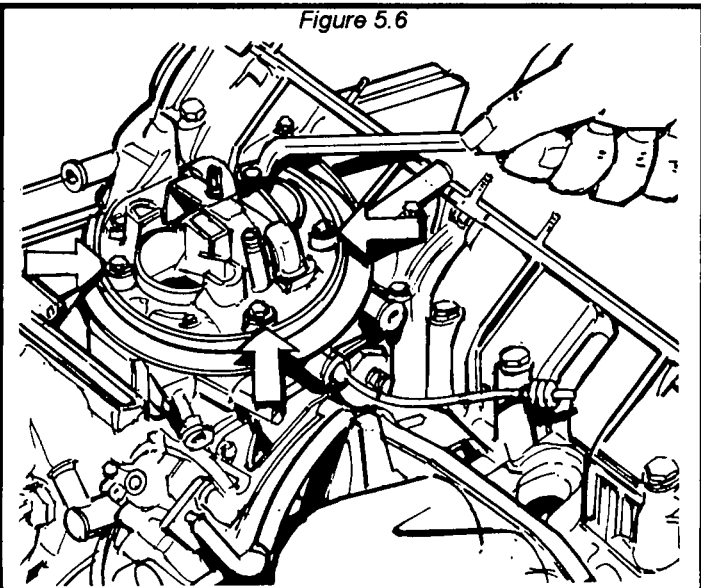

Figure 5.6

**Refitting carburetor with gasket**

(See Figure 5.6)

**NOTE:** Pay attention to reconnect the wires and pipes correctly.



# ENGINE REASSEMBLY

Figure 5.7

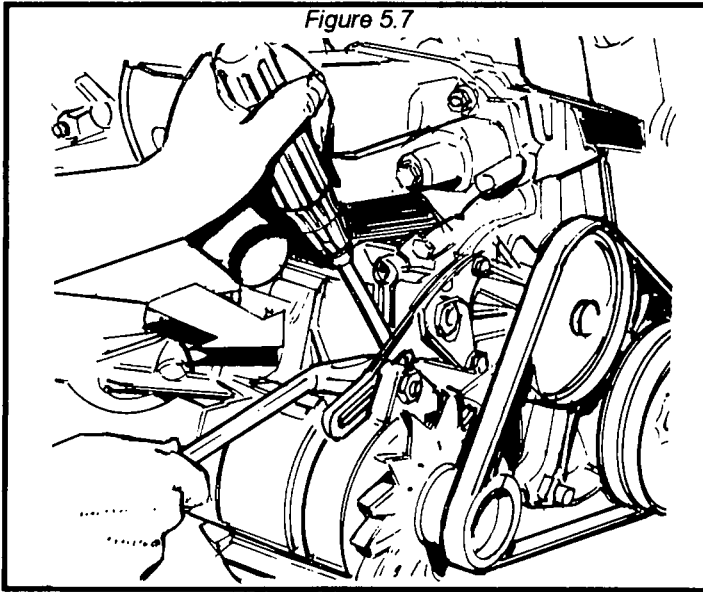

## Refitting alternator, fitting and tensioning crankshaft poly-V-belt

\* Fit the belt at the same time rotating the fly-wheel to facilitate fitting.

\* Adjust the belt tension, then tighten the alternator fixing bolt to 36 ft-lb. (See Figure 5.7)

Figure 5.8

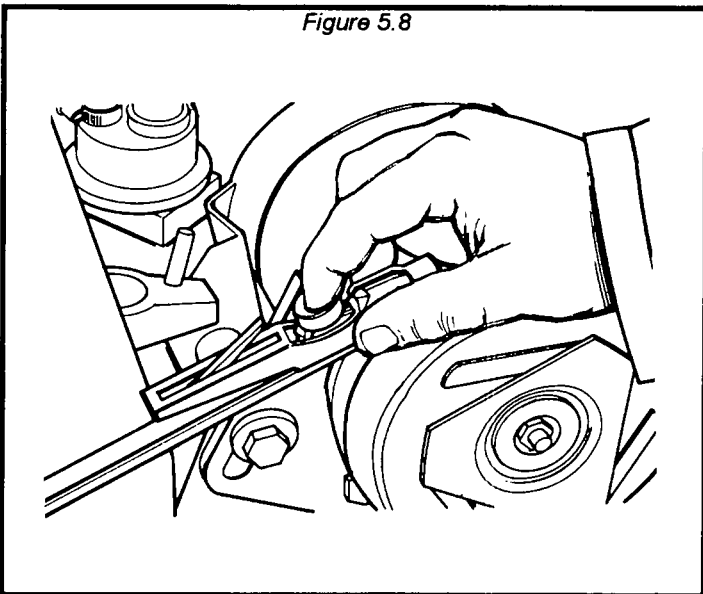

## Checking tension of crankshaft poly-V-belt

During the periodic check to be carried out annually, it is typical for a poly V-belt to have a fluctuation of approximately  $\frac{1}{4}$ " either way.

(See Figure 5.8)

**NOTE:** The periodic check on the belt tension should be carried out with the engine cold.

Figure 5.9

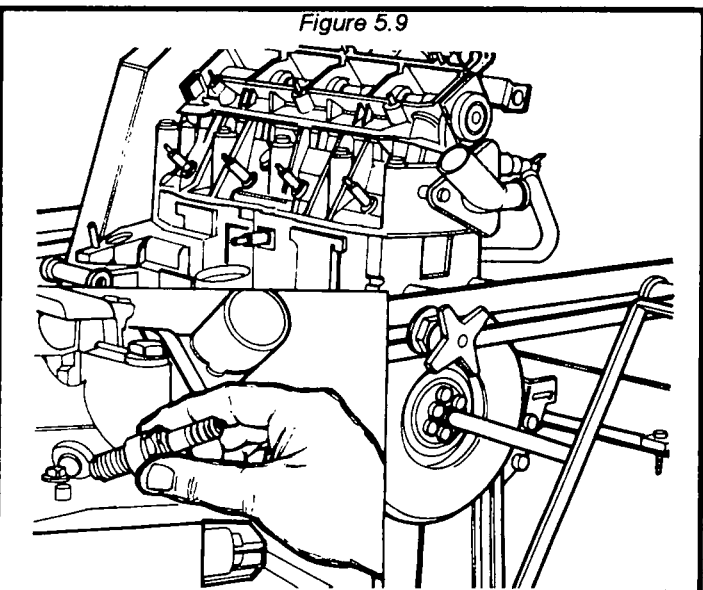

## Refitting spark plugs (See Figure 5.9)

**NOTE:** This engine is equipped with an aluminum cylinder head. It is recommended to apply a small amount of anti-seize compound before installation. (Torque to: 27 ft-lb).

# ENGINE REASSEMBLY

Figure 5.10

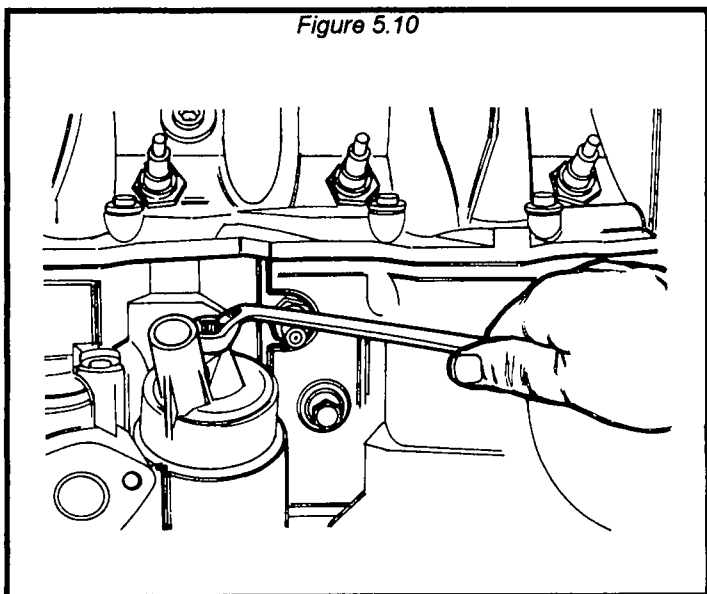

**Refitting oil vapor recovery device**  
(See Figure 5.10)

Figure 5.11

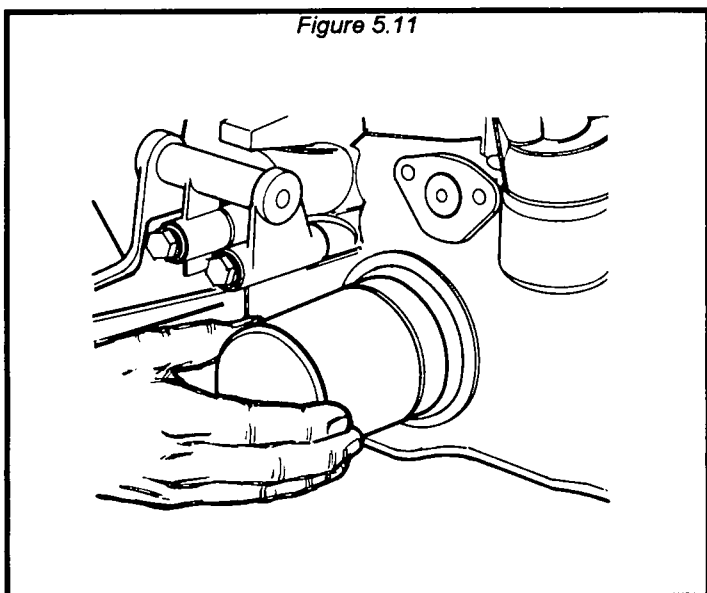

**Refitting cartridge oil filter**

Tighten the oil filter by hand turning it till the filter seal makes contact with the filter mounting base, then turn it 1/2 to 3/4 turn afterwards.

**NOTE:** Before fitting the oil filter, lubricate the seal with a thin coat of engine oil, then tighten the filter on to the mounting pad by hand.

Figure 5.12

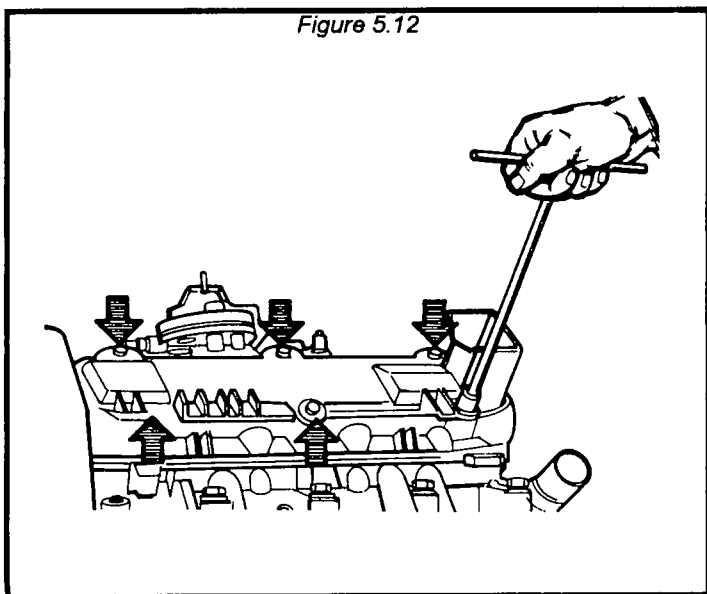

**Refitting tappet cover**

Install tappet cover gasket to tappet cover via a thin coat of RTV Silicone or or similar gasket sealer. leave the surface of the gasket which will touch the camshaft housing dry.

**NOTE:** Make sure that all gasket surfaces are free from oil or grease, and during the tightening process use **CAUTION** not to cause the gasket to "mash" out from the sides of the tappet cover due to over tightening.

# ENGINE REASSEMBLY

Figure 5.13

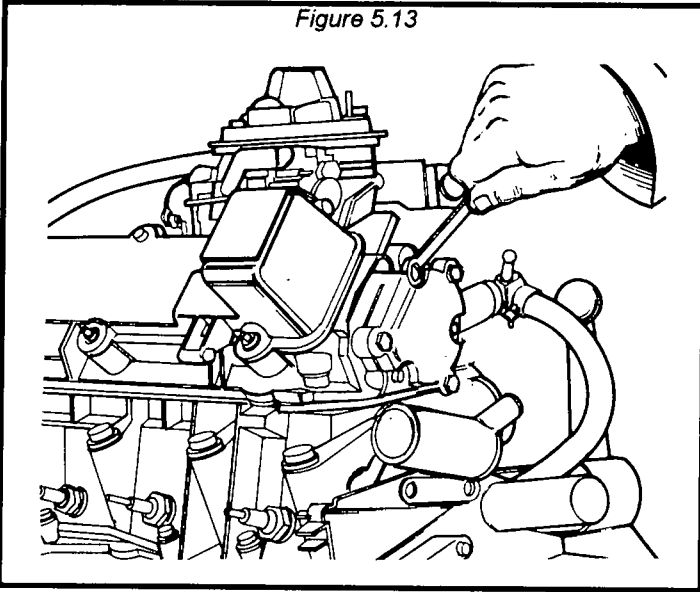

## Refitting camshaft rear cover

Apply a thin coating of RTV or similar sealer to the related gasket for the rear camshaft cover and install. (See Figure 5.13)

Figure 5.14

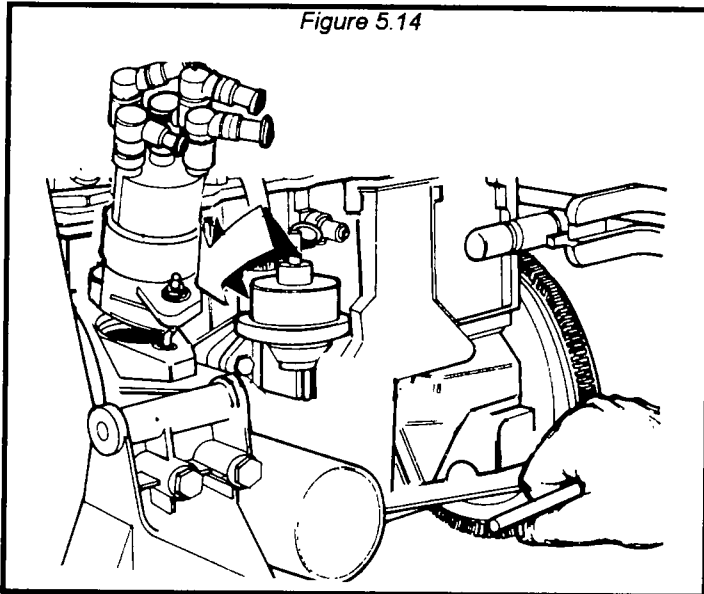

## Refitting ignition distributor

Make sure that the rotary arm contact is towards the reference mark shown by the arrow in Figure 5.14.

**NOTE:** Take care to refit the distributor in the correct position.

Figure 5.15

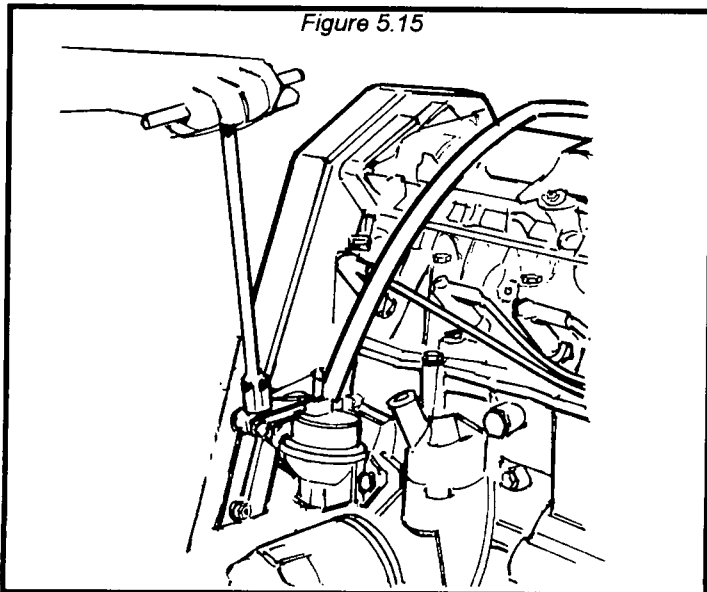

## Refitting oil pump drive gear access hole sealing plug

(See Figure 5.15)

## ENGINE REASSEMBLY

Figure 5.16

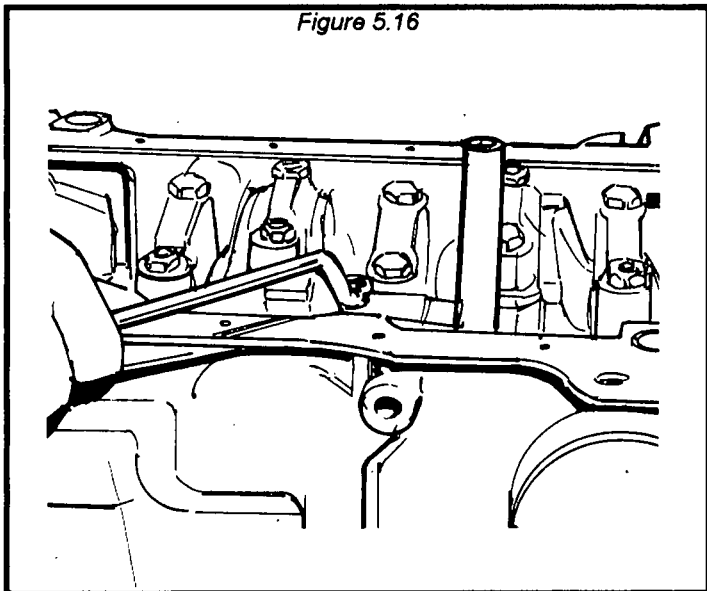

**Refitting oil vapor return pipe**  
(See Figure 5.16)

Figure 5.17

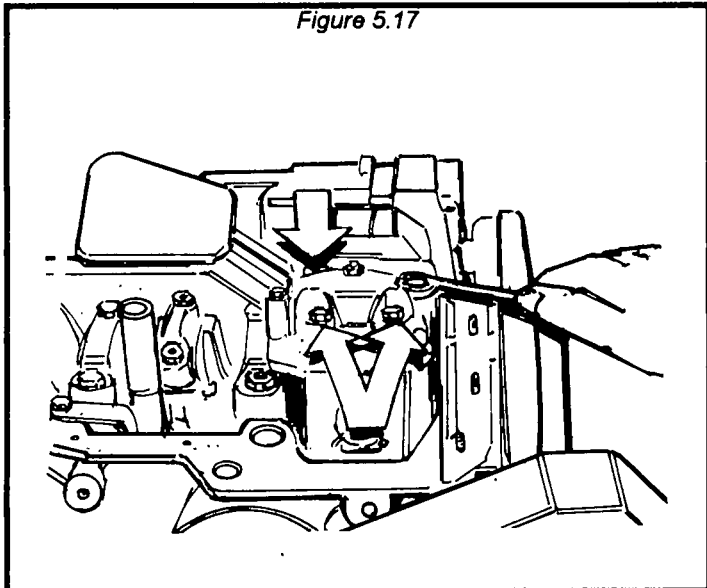

**Refitting oil pump**  
(See Figure 5.17)

**NOTE:** It is recommended to lubricate the oil pump with recommended engine oil prior to installation.

Figure 5.18

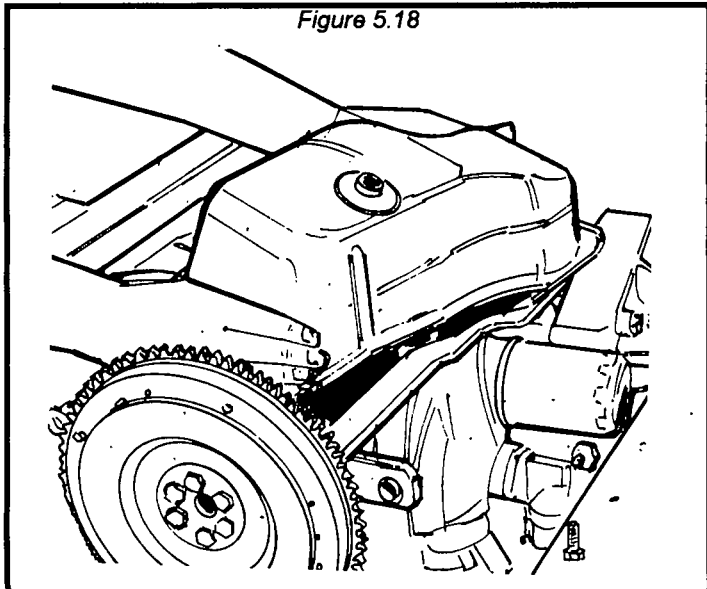

**Refitting oil pan and gasket**

Place a thin coating of RTV or similar sealer on the oil pan gasket surface, and install gasket to pan, leave cylinder block gasket surface dry

**NOTE:** In order to position the oil sump correctly on the crankcase without damaging the pump, it should be rotated before it is rested in place.

# ENGINE REASSEMBLY

Figure 5.19

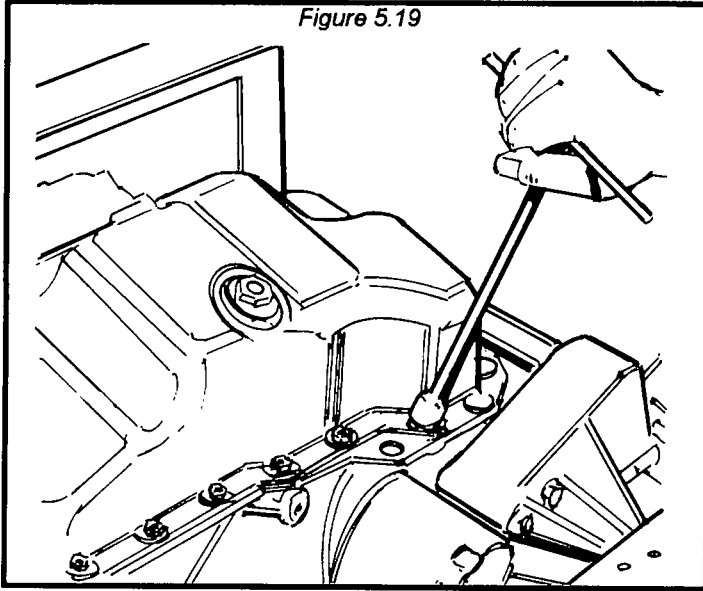

**Tightening oil pan bolts and nuts (7.5 ft-lb)**  
(See Figure 5.19)

Figure 5.20

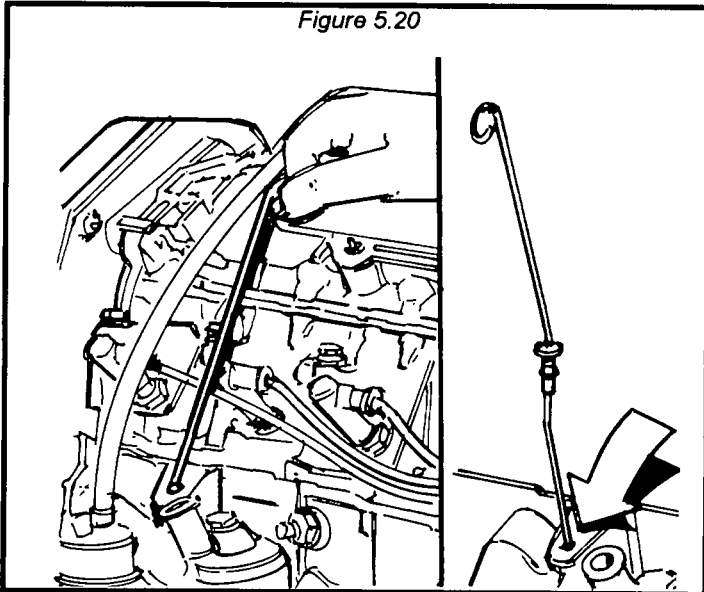

**Fitting engine oil dipstick**  
(See Figure 5.20)

**NOTE:** For further reassembly instructions, refer to page 3 and reverse order of disassembly.

# TECHNICAL DATA

*Main bearing supports*

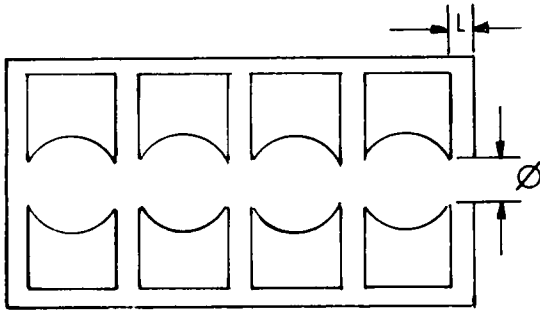

Location	Tolerance
L	.87165-.87401 in.
1	2.14594-2.14645 in.
2	2.14594-2.14645 in.
3	2.14594-2.14645 in.

*Auxiliary shaft bearing housings*

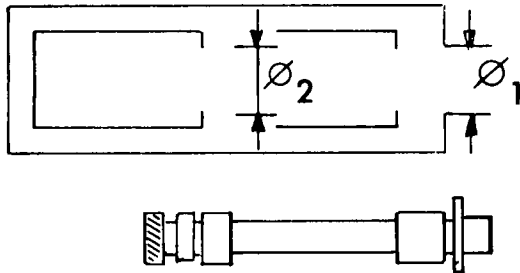

Location	Tolerance
Bearing 1	1.5236-1.5248 in.
Bearing 2	1.37937-1.38055 in.

*Cylinder bore*

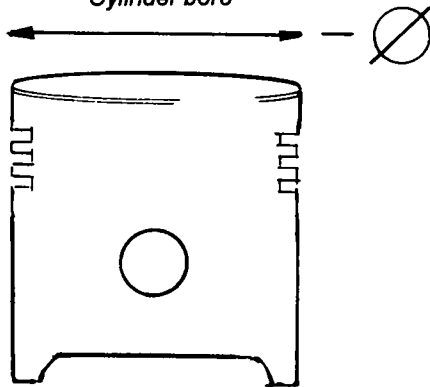

Location	Tolerance
Cylinder bore	3.36417-3.40157 in.

*Piston*

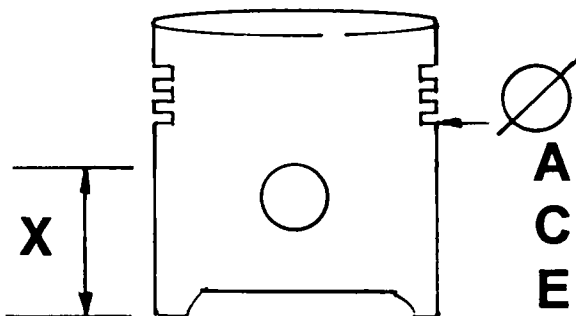

Location	Tolerance
X	.7874 in.
A	3.4000-3.4004 in.
C	3.4007-3.4012 in.
E	3.4015-3.4019 in.

# TECHNICAL DATA

*Crankshaft bearings*

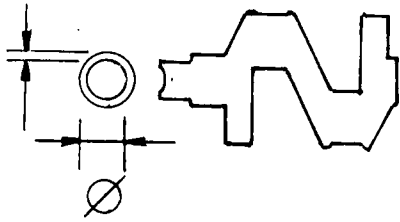

Location	Tolerance
1	.07244-.07259 in.
2	.07263-.07279 in.
Ø	0.100-0.20 in.
<b>Crankshaft bearing main journals</b>	
.000748-.00196 in.	

*Crank pins*

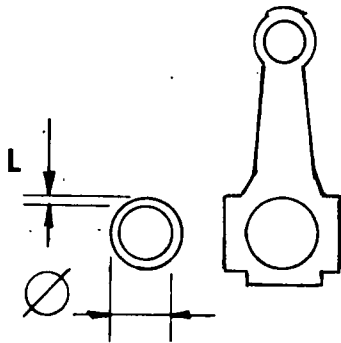

Location	Tolerance
A	.06043-.060669 in.
B	.06063-.06086 in.
Ø	.0100-.0200 in.
<b>Big end bearings- Main journals</b>	
.000984-.00248 in.	

*Location of thrust washers*

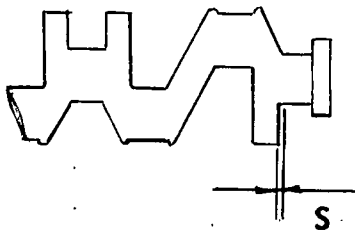

Location	Tolerance
S	.090944-.09291 in.
S	.0050 in.

*Crankshaft end play*

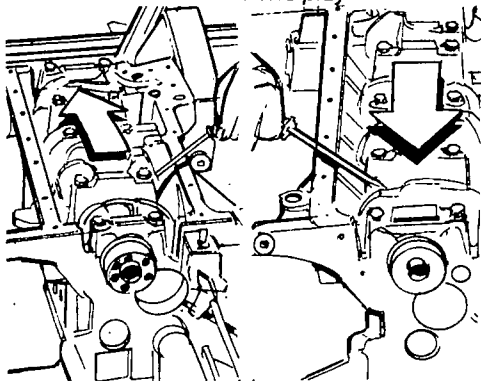

<b>Crankshaft end play</b>
.002165-.010433 in.

# TECHNICAL DATA

Piston cylinder bore, gudgeon pin housing

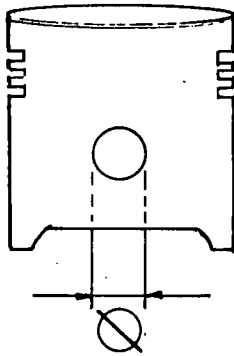

**Piston cylinder bore:** .00118-.00198 in.

**Gudgeon pin housing Ø 1=** .86598-.8661 in.

**Gudgeon pin housing Ø 2=** .8661-.8662 in.

**Gudgeon pin housing Ø=** .00787 in.

Piston gudgeon pin

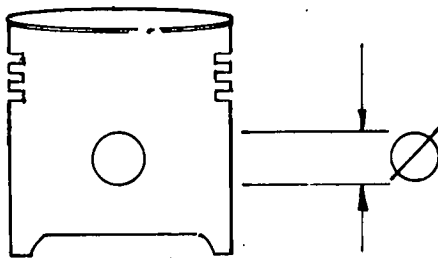

**Gudgeon pin Ø 1=** .8657-.8659 in.

**Gudgeon pin Ø 2=** .8659-.8660 in.

Piston rings and grooves

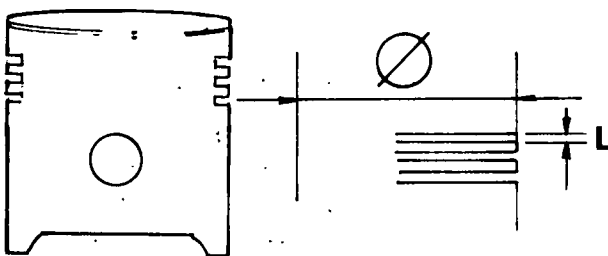

**Piston ring grooves**

Location	Tolerance
1	.06044- .06122 in.
2	.0700-.07086 in.
3	.1188-.1197 in.

Piston ring gap

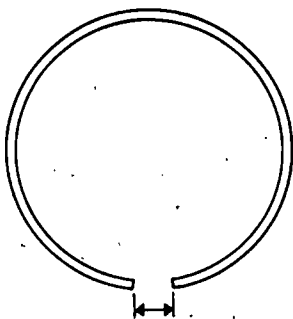

**Piston ring end gap**

Location	Tolerance
1	.0012-.0030 in.
2	.0012-.0197 in.
3	.0098-.0197 in.

# TECHNICAL DATA

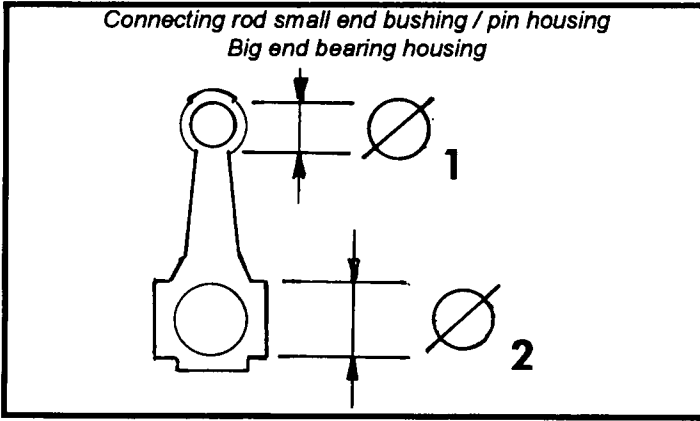

Location	Tolerance
$\varnothing_1$	.9425-.9438 in.
$\varnothing_{2a}$	1.9145-1.9152 in.
$\varnothing_{2b}$	1.9145-1.9152 in.
$\varnothing_{2c}$	1.9145-1.9152 in.

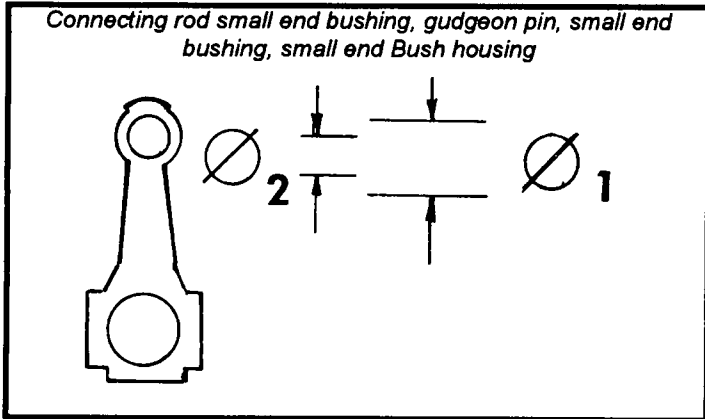

Location	Tolerance
$\varnothing_1$	.9455-.9465 in.
$\varnothing_{21}$	.8663-.8664 in.
$\varnothing_{22}$	.8664-.8665 in.
<b>Gudgeon pin small end bush</b>	
.00039-.00063 in.	
<b>Small end bush, and bush housing</b>	
.0017-.0040 in.	

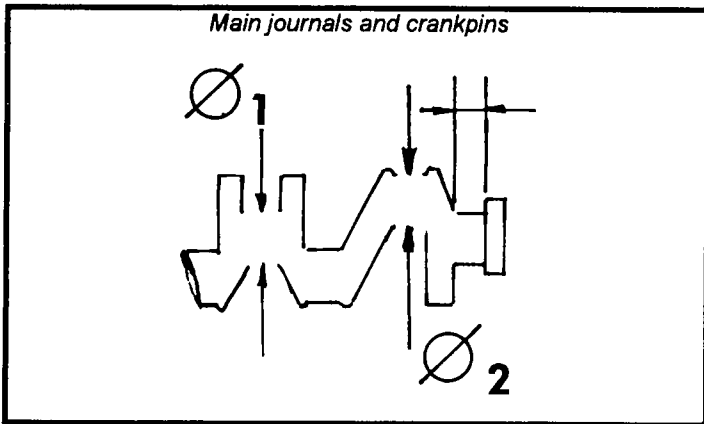

Location	Tolerance
<b>Main journals:</b>	
$\varnothing_{11}$	1.9996-2.000 in.
$\varnothing_{12}$	1.9992-1.9996 in.
<b>Crankpins:</b>	
$\varnothing_{2A}$	1.7919-1.7922 in.
$\varnothing_{2B}$	1.7915-1.7919 in.
L	1.0620-1.0634 in.

# TECHNICAL DATA

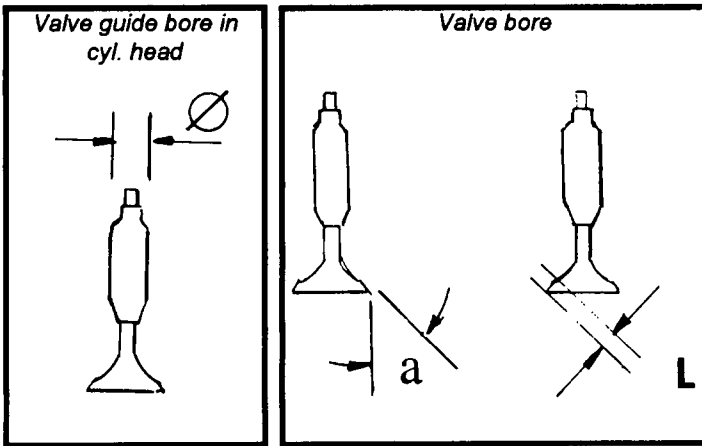

Location	Tolerance
Valve guide bore in cyl. head Ø:	.5492-.5503
Valve face angle:	45°
Valve face width:	.0787 in.
Combustion chamber volume:	33.7 c.c.

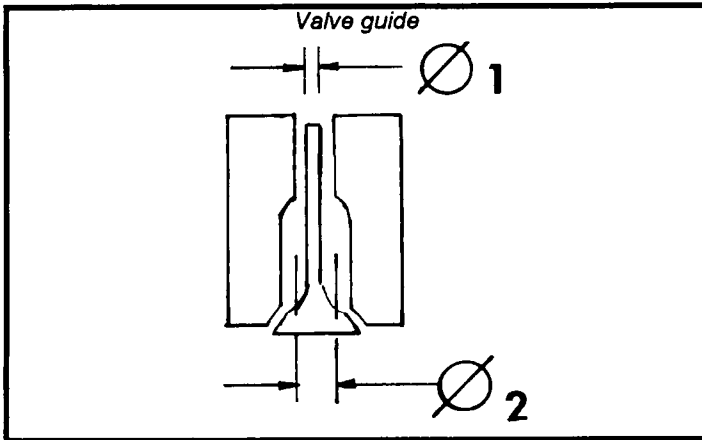

Location	Tolerance
Ø <sub>1</sub> (inner diameter)	.3158-.3165 in.
Ø <sub>2</sub> (outer diameter)	.5528-.5535 in.

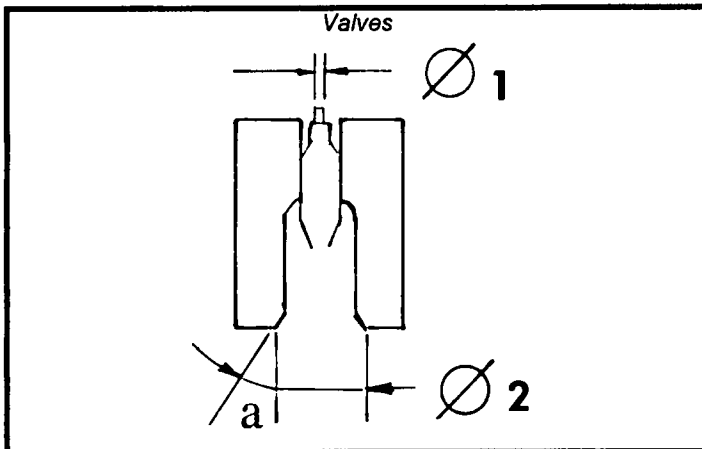

Location	Tolerance
<b>Intake:</b>	
Ø <sub>1</sub> (stem diameter)	.3139-.3146 in.
Ø <sub>2</sub> (head diameter)	1.5433-1.5629 in.
Valve face	45°
<b>Exhaust:</b>	
Ø <sub>1</sub> (stem diameter)	.3139-.3146 in.
Ø <sub>2</sub> (head diameter)	1.2146-1.2264 in.
Valve face	45°
<b>Valve to valve guide clearance:</b>	
.00118-.0026 in.	

# TECHNICAL DATA

Valve springs

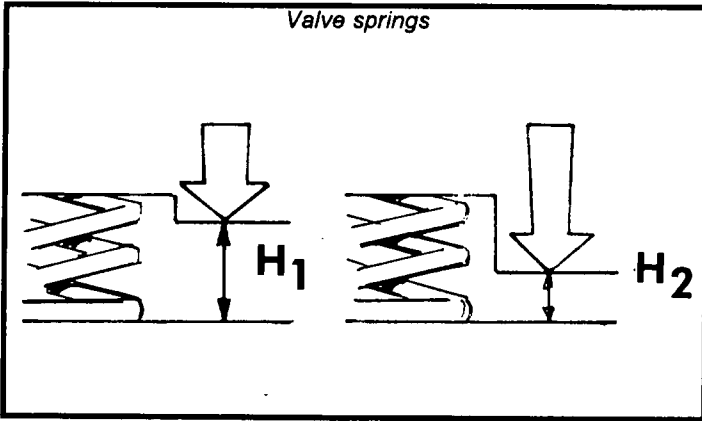

## Inner valve spring:

Installed pressure: 31.7-33.9 lb

Free height: 1.2204 in

Pressure at lift: 59.3-64.5 lb

Installed height: .8464 in

## Outer valve spring:

Installed pressure: 82.5-89 lb

Free height: 1.4173 in

Pressure at lift: 125.6-136.6 lb

Installed height: 1.0433 in

Camshaft bearings

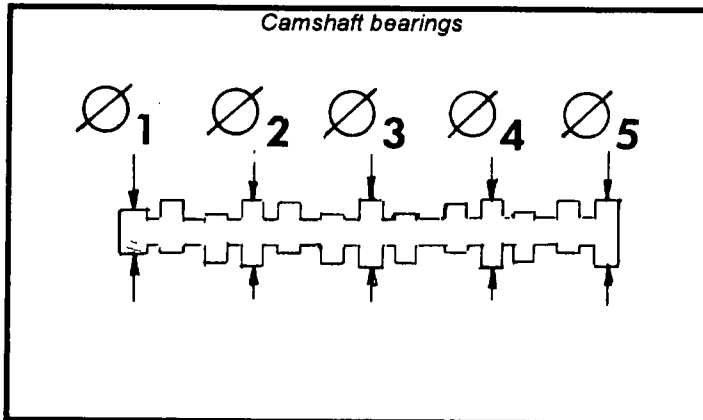

Location	Tolerance
$\varnothing_1$	1.1789-1.1795 in.
$\varnothing_2$	1.8872-1.8878 in.
$\varnothing_3$	1.8951-1.8957 in.
$\varnothing_4$	1.9029-1.9035 in.
$\varnothing_5$	1.9108-1.9114 in.

Camshaft lift

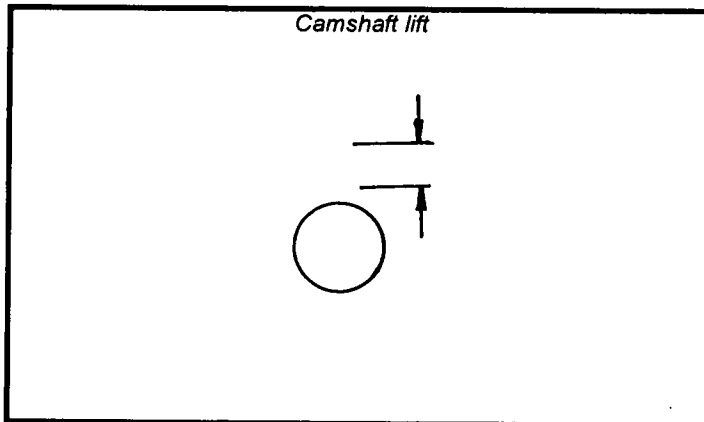

Location	Specification
Intake lobe	.346 in
Exhaust lobe	.346 in

Cam bearings in housing

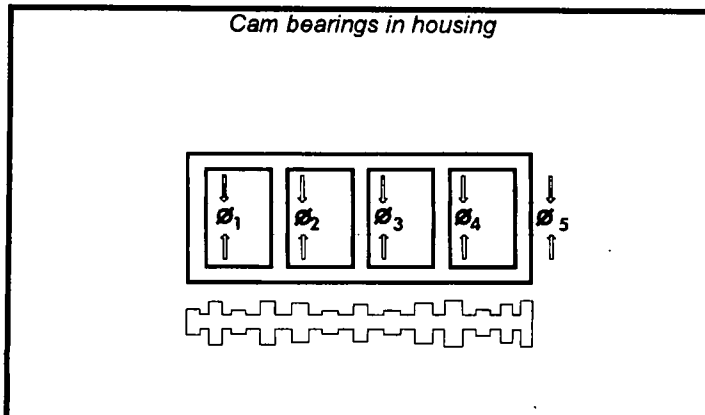

Location	Tolerance
$\varnothing_1$	1.1807-1.1817 in.
$\varnothing_2$	1.8889-1.8900 in.
$\varnothing_3$	1.8969-1.8978 in.
$\varnothing_4$	1.9047-1.9057 in.
$\varnothing_5$	1.9125-1.9136 in.

# TECHNICAL DATA

*Tappet housing in cylinder head*

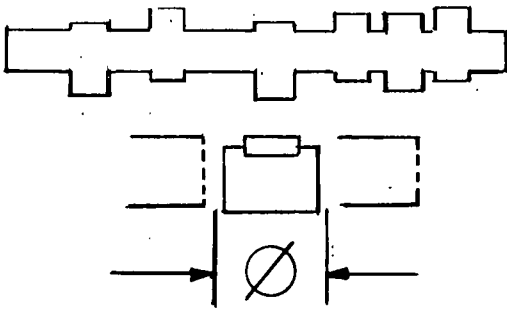

Location	Tolerance
Ø	1.4567-1.4578 in
<b>Camshaft bearings and housing support</b>	
	.0012-.0028 in

*Tappet*

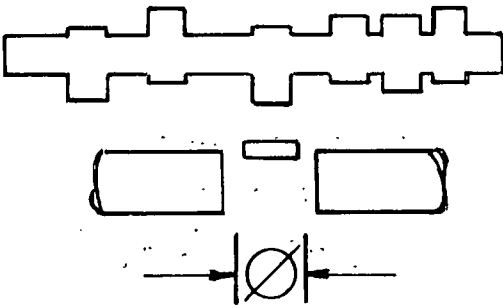

Location	Tolerance
Ø	1.4557-1.4565 in.
<b>Tappet housing, cylinder head</b>	
	.0002-.002 in.

*Shim*

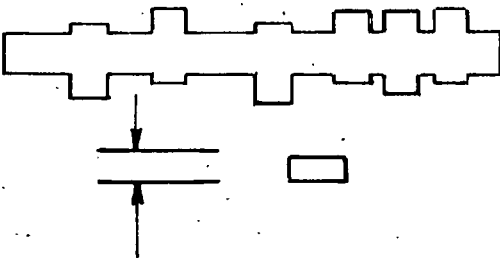

Location	Tolerance
S	.1279-.1850 in.

*Timing diagrams*

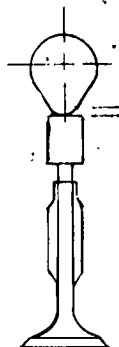

Valve clearance
<b>Intake:</b> .0315 in.
<b>Exhaust:</b> .0315 in.
Operational clearance:
<b>Intake:</b> .0157± .002 in.
<b>Exhaust:</b> .0197± .002 in.

# TECHNICAL DATA

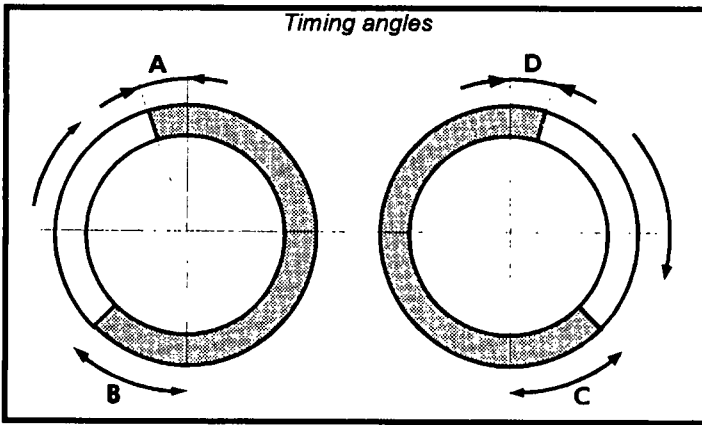

Location	Specification
(A) Intake opens BTDC	7°
(B) Intake closes ABDC	35°
(C) Exhaust opens ABDC	37°
(D) Exhaust closes ATDC	5°

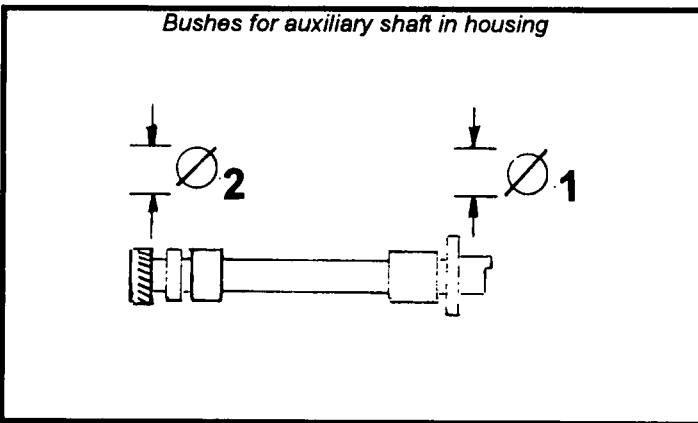

Location	Tolerance
Ø <sub>1</sub>	1.4041-1.4049 in.
Ø <sub>2</sub>	1.2598-1.2606 in.

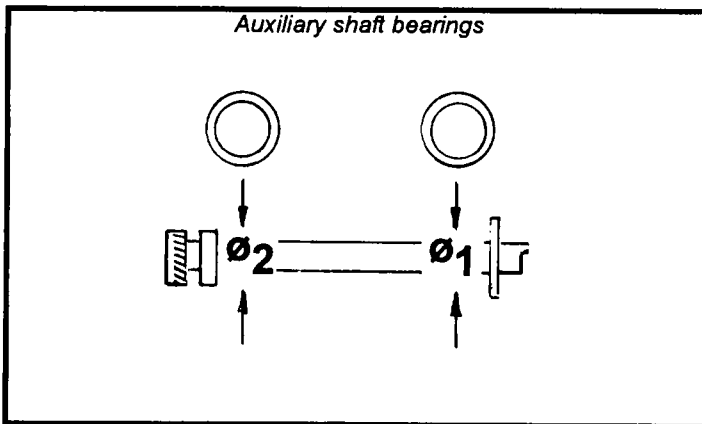

Location	Tolerance
Ø <sub>1</sub>	1.4013-1.4023 in.
Ø <sub>2</sub>	1.2575-1.2583 in.
<b>Bushes for shaft, cylinder block seats</b> (Must be an interference fit)	
<b>Shaft bushes</b>	
Ø <sub>1</sub>	.0018-.0036 in.
Ø <sub>2</sub>	.0016-.0032 in.

## TECHNICAL DATA

### **OIL PUMP:**

**Engine lubrication system:** Force feed by means of geared pump with cartridge oil filter in series.

**Oil pump drive type:** Gear driven

**Pump operated via:** the auxiliary shaft

**Oil pressure relief valve:** Incorporated in oil pump

**Full flow filter:** Cartridge

**Oil pressure sending unit:** Electrical

**Oil pump pressure:** at idle speed = 21.75 psi. Operating pressure at 100°C at 4000 rpm. = 66.7 psi

### **COOLING SYSTEM:**

**Cooling circuit:** Coolant circulation via centrifugal pump, radiator and two speed electrical fan operated by thermostatic switch.

**Thermostat:** opens between 85° and 89°C. (Max opening between 96° and 100°C).

**Pressure for checking system water tightness:** 14.21 psi.

**Engine idle speed:** 850 rpm.

## TECHNICAL DATA (Torque Specifications)

<b>Main bearing cap bolt M10 x 1.25):</b>	<b>59 ft-lb</b>
<b>Cylinder head to crankcase bolt (M10 x 1.25):</b>	<b>29.5 ft-lb</b>
<b>Cylinder head to crankcase bolt (M8 x 1):</b>	<b>22 ft-lb</b>
<b>Camshaft housing to lower cylinder head (M8):</b>	<b>18.5 ft-lb</b>
<b>Big end, nut for bolt (M9 x 1):</b>	<b>37.5 ft-lb</b>
<b>Engine breather to crankcase bolt (M8)</b>	<b>18.5 ft-lb</b>
<b>Front cover to crankcase bolt (M10 x 1.25):</b>	<b>37 ft-lb</b>
<b>Front cover to crankcase bolt (M8):</b>	<b>18.5 ft-lb</b>
<b>Rear cover (flywheel side) to crankcase bolt (M6):</b>	<b>7.5 ft-lb</b>
<b>Inlet and exhaust manifold to cyl head nut (M8):</b>	<b>20.5 ft-lb</b>
<b>Flywheel to crankshaft bolt (M10 x 1.25):</b>	<b>61 ft-lb</b>
<b>Belt shield (lower) bolt (M8):</b>	<b>18.5 ft-lb</b>
<b>Power unit mounting support to crankcase bolt (M10 x 1.25)</b>	<b>59 ft-lb</b>
<b>Auxiliary shaft pulley to crankshaft nut (M20 x 1.25):</b>	<b>101 ft-lb</b>
<b>Camshaft drive gear bolt (M10 x 1.25)</b>	<b>61 ft-lb</b>
<b>Belt tensioner nut (M8):</b>	<b>16 ft-lb</b>
<b>Auxiliary shaft driven gear for oil pump, bolt (M10 x 1.25):</b>	<b>61 ft-lb</b>
<b>Oil pressure switch (M14 x 1.5):</b>	<b>23.5 ft-lb</b>
<b>Coolant temperature sending unit (M16 x 1.5):</b>	<b>22 ft-lb</b>
<b>Spark plugs (M14 x 1.25):</b>	<b>27 ft-lb</b>
<b>Engine oil sump bolt (M6 x 1):</b>	<b>7.5 ft-lb</b>
<b>Engine oil sump nut (M6 x 1):</b>	<b>7.5 ft-lb</b>
<b>Alternator upper bracket nut for bolt (M10 x 1.25):</b>	<b>37 ft-lb</b>
<b>Alternator to lower mounting nut (M10 x 1.25):</b>	<b>37 ft-lb</b>
<b>Lower alternator mounting to crankcase bolt (M10 x 1.25):</b>	<b>51.5 ft-lb</b>
<b>Oil seal cover on crankcase bolt (M6):</b>	<b>6 ft-lb</b>
<b>Exhaust pipe to manifold nut (M8 x 1.25):</b>	<b>13 ft-lb</b>

# GENERAC CORPORATION

## MASTER G.E.N. EXPRESS NETWORK

**Billiou's INC. (CA, NV, UT, CO, AZ, ID, OR, WA)**

1343 South Main Street  
Porterville, CA. 93257  
Parts: (800) 245-5468  
Fax: (209) 781-1875  
Phone (209) 784-4102

**Canada Power Tech**

161 Watline Ave.  
Mississauga, Ont.  
Canada L4Z 1P2  
Phone: (905) 890-6900  
Fax: (905) 890-6900

**Canada Power Tech**

13315-146 St.  
Edmonton, Alberta  
Canada 4S3 1P2  
Phone: (403) 453-5791  
Fax: (403) 454-8377

**Canada Power Tech**

226 Migneron St.  
Ville St. Laurent, Québec  
Canada H4T 1Y7  
Phone: (514) 731-3559  
Fax: (514) 731-0064

**Central Power Distributers (MN, ND, SD)**

1101 Mckinley Street  
Anoka, MN 55303  
Phone: (612) 576-0901  
Fax: (612) 576-0920

**Dixie Sales Company (VA, NC, SC)**

P.O. Box 1408  
Greensboro, NC 27402  
(800) 753-4943  
Phone: (910) 375-7500  
Fax: (910) 621-3555

**Gardner West (WV, KT, IN, OH, MI)**

1150 Chesapeake Ave  
Columbus, OH 43212  
Phone: (614) 488-7951  
Fax: (614) 486-7122

**Gardner East (PA, MD, DC, DE, NJ, NY, CN, MA, NH, VT, ME)**

106 Merlich Rd  
Cranbury, NJ 08512  
Phone: (609) 860-8060  
Fax: (609) 860-8040

**Industrial Engine and Parts (WI, IL, IA)**

50 Noll Street  
Waukegan, IL. 60085  
(800) 210-0393  
Phone: (708) 263-0500  
Fax: (708) 263-0528

**Marr Brothers (TX, NM, OK, AR, LA)**

423 E. Jefferson  
Dallas, TX 75209  
(800) 627-7276  
Phone: (214) 948-7387  
Fax: (800) 967-1259

**Medart Engines (MO)**

100 Larkin Williams Ct.  
Fenton, MO 63026  
(800) 888-7181  
Phone: (314) 343-0515  
Fax: (800) 695-9530

**Medart Engines (KS)**

2644 S. 96th St.  
Edwardsville, KS 66111  
(800) 888-7181  
Phone: (314) 343-0515  
Fax: (800) 695-9530

**Medart Engines (TN)**

4365 Old Lemar  
Memphis, TN 38118  
(800) 888-7181  
Phone: (314) 343-0515  
Fax: (800) 695-9530

**Original Equipment (MT, WY)**

905 Second Ave. South  
Billings, MT 59103  
(800) 332-7158  
Phone: (406) 245-3081  
Fax: (406) 245-1652

**Radco Distributers (FL, GA, AL, MS)**

11820 Central Parkway  
Jacksonville, FL 32224  
(800) 727-8701  
Phone: (904) 641-7278  
Fax: (800) 727-8703

# GENERAC CORPORATION

## CERTIFIED CENTRAL SERVICE NETWORK

**A/C Energy (IL, WI, N.W. corner of IN, Counties of Lake,  
3129 Louis Sherman Dr. Porter, LaPorte & St. Joseph)  
Steger, IL 60475**  
**Parts: (800) 800-0822**  
Phone (708) 758-2007  
Fax: (708) 758-2031

**Clifford Power Systems (OK, AR, MO, TX North of I-20)**  
P.O. Box 581807  
Tulsa, OK 74158  
**Parts: (800) 324-0066**  
Phone: (918) 836-0066  
Fax: (918) 836-0094

**Hunter & Lomison (PA, NY West of I-21)**  
1956 W. Fourth Street  
Williamsport, PA 17701  
**Parts: (800) 922-9540**  
Phone: (717) 326-1764  
Fax: (717) 326-5042

**Indiana Power & Service (IN, KY, OH)**  
1415 Country Club Rd.  
Indianapolis, IN 46234  
**Parts: (800) 229-1672**  
Phone: (317) 271-1672  
Fax: (317) 271-1673

**Marr Brothers (NM, LA, TX South of I-20)**  
423 E. Jefferson  
Dallas, TX 75209  
**Parts: (800) 627-7276**  
Phone: (214) 948-7387  
Fax: (800) 967-1259

**Certified Electrical Distributors (NC, SC, GA, TN East of  
P.O. Box 10967 TN river)**  
Rock Hill, SC 29731  
**Parts: (800) 843-9103**  
Phone: (803) 684-0085  
Fax: (803) 684-1228

**Energy Systems, INC (CA, NV, UT, CO)**  
P.O. Box 31420  
Stockton, CA 95213  
**Parts: (800) 845-8519**  
Phone: (209) 983-6900  
Fax: (209) 983-8919

**Huntington Power (ME, VT, NH, Eastern NY, MA, CT, RI,  
P.O. Box 2040 NJ)**  
Shelton, CT 06484  
**Parts: (800) 473-1408**  
Phone: (203) 929-3203  
Fax: (800) 929-0713

**Kelly Generator (VA, WV, MD, DE)**  
8421-A Westphalia Rd  
Upper Marlboro, MD 20772  
**Parts: (800) 677-3815**  
Phone: (301) 420-3983  
Fax: (301) 736-6582

**Nickel Equipment ((MI, UP)**  
1006 S. Division Ave  
Grand Rapids, MI 49507  
**Parts: (800) 638-2440**  
Phone: (616) 241-2448  
Fax: (616) 241-4095

**TW Enterprises (MT, WY, ID)**  
2059 N. 9th Rd.  
Worden, MT 59088  
**Parts: (800) 955-3795**  
Phone: (406) 245-4600  
Fax: (406) 245-4333









