

**GENERAC**<sup>®</sup>  
POWER SYSTEMS, INC.

**7.5** LITER

***MITSUBISHI  
DIESEL  
ENGINE***

---

***SERVICE  
MANUAL***

# FOREWORD

This manual has been published by GENERAC<sup>®</sup> POWER SYSTEMS, INC. to aid our dealers' mechanics, company service personnel and general consumers when servicing the products described herein.

It is assumed that these personnel are familiar with the servicing procedures for these products, or like or similar products, manufactured and marketed by GENERAC<sup>®</sup> POWER SYSTEMS, INC. It is also assumed that they have been trained in the recommended servicing procedures for these products, which includes the use of mechanics hand tools and any special tools that might be required.

Proper service and repair is important to the safe, economical and reliable operation of the products described herein. The troubleshooting, testing, service and repair procedures recommended by GENERAC<sup>®</sup> POWER SYSTEMS, INC. and described in this manual are effective methods of performing such operations. Some of these operations or procedures may require the use of specialized equipment. Such equipment should be used when and as recommended.

We could not possibly know of and advise the service trade of all conceivable procedures or methods by which a service might be performed, nor of any possible hazards and/or results of each procedure or method. We have not undertaken any such wide evaluation. Therefore, anyone who uses a procedure or method not recommended by the manufacturer must first satisfy himself that neither his safety, nor the product's safety, will be endangered by the service or operating procedure selected.

All information, illustrations and specifications contained in this manual are based on the latest product information available at the time of publication. However, GENERAC<sup>®</sup> POWER SYSTEMS, INC. reserves the right to change, alter or otherwise improve the product at any time without prior notice.

Some components or assemblies of the product described in this manual may not be considered repairable. Disassembly, repair and reassembly of such components may not be included in this manual.

The engines described herein may be used to power a wide variety of products. Service and repair instructions relating to any such products are not covered in this manual. For information pertaining to use of these engines with other products, refer to any owner's or service manuals pertaining to said products.

**GENERAC SERVICE RECOMMENDATIONS** ..... A\_2  
**MITSUBISHI FOREWORD AND CONTENTS** .....

The 7.5 Liter Diesel Engine has been engineered for use in Generac Power Systems products. The contents of this manual have been reprinted from the original manufacturer's service and repair manual.

## 7.5 Liter Diesel Engine Service Recommendations

### ◆ ENGINE OIL RECOMMENDATIONS

The unit has been filled with “break in” engine oil at the factory. Use a high-quality detergent oil classified “For Service CC, SD, SE or SF.” Detergent oils keep the engine cleaner and reduce carbon deposits. Use oil having the following SAE viscosity rating, based on the ambient temperature range anticipated before the next oil change:

#### Engine Lubrication System:

Type of Oil Pump .....Gear  
Oil Filter .....Full Flow, Cartridge  
Crankcase Oil Capacity .....22.7 L (6 U.S. gals.)

Temperature	Oil Grade (Recommended)
Above 86° F (30° C)	SAE 40 or 15W-40
32° to 86° F (0° to 30° C)	SAE 30 or 15W-40
Below 32° F (0° C)	SAE 20W or 15W-40
All Seasons	SAE 15W-40

### ◆ COOLANT

Use a mixture of half low silicate, ethylene glycol base antifreeze and half soft water. Use only soft water and only low silicate antifreeze. If desired, you may add a high quality rust inhibitor to the recommended coolant mixture. When adding coolant, always add the recommended 50-50 mixture.

#### Cooling System:

Type.....Pressurized, Closed Recovery  
Coolant Capacity  
System .....17.5 L (4.6 U.S.gals.)  
Engine.....8.5 L (2.24 U.S.gals.)



**DANGER**



Do not remove the radiator pressure cap while the engine is hot or serious burns from boiling liquid or steam could result.



Ethylene glycol base antifreeze is poisonous. Do not use your mouth to siphon coolant from the radiator, recovery bottle or any container. Wash your hands thoroughly after handling. Never store used antifreeze in an open container because animals are attracted to the smell and taste of antifreeze even though it is poisonous to them.



**CAUTION**



Do not use any chromate base rust inhibitor with ethylene glycol base antifreeze, or chromium hydroxide (“green slime”) will form and cause overheating. Engines that have been operated with a chromate base rust inhibitor must be chemically cleaned before adding ethylene glycol base antifreeze. Using any high silicate antifreeze boosters or additives also will cause overheating. We also recommend that you DO NOT use any soluble oil inhibitor for this equipment.

### PERIODIC MAINTENANCE SCHEDULE:

#### SERVICE SCHEDULE

##### ◆ AUTHORIZED OPERATOR MAINTENANCE FUNCTIONS

###### Every Month or 100 Hours

(whichever comes first)

- Test standby generator system.
- Inspect battery and cables.
- Check engine oil level.
- Check gearbox oil level (if so equipped).
- Check engine coolant level.
- Check generator ground connections.
- Test/inspect starting aids.

###### Every Three Months or Every 120 Hours

(whichever comes first)

- Inspect and test fuel system and connections.
- Inspect exhaust system.
- Inspect/test fuel supply system.

##### ◆ AUTHORIZED SERVICE TECHNICIAN MAINTENANCE FUNCTIONS

###### After First 30 Hours of Operation

- Inspect wiring.
- Change engine crankcase oil and oil filter.
- Inspect engine fan belts.
- Inspect battery and cables.

###### Every Six Months or Every 100 Hours

(whichever comes first)

- Change engine oil and filter.
- Lubricate engine controls.
- Service engine air cleaner.
- Service engine fuel filter.
- Inspect AC generator.
- Test engine safety controls.
- Inspect fan belts.
- Check engine coolant level.
- Inspect engine cooling system hoses.
- Check optional starting aids.
- Check battery.
- Check engine compression.
- Check electrical connections.
- Check/test annunciator panel.
- Perform operational test.

###### Annually or Every 600 Hours

(whichever comes first)

- Check engine valve clearance.
- Test fuel injection nozzles.
- Test injection timing.
- Inspect all wiring.
- Test engine starter operation.
- Drain water from fuel tank.
- Retorque fan bolts.
- Drain and refill gearbox (if so equipped)

###### Every Two Years

- Replace all rubber hoses.
- Replace engine fan belts.
- Inspect the Standby Generator System.
- Drain, flush, refill cooling system.

###### Every 1,000 Operating Hours

- Inspect engine DC alternator.
- Inspect engine starter.
- Retorque engine mounting brackets.
- Remove/test fuel injection pump.
- Remove/test cooling system thermostat.

###### As Required

- Bleed engine fuel system.



# 6D1

## diesel engine

# Shop Manual

(for industrial use)

## FOREWORD

This Shop Manual is published for the information and guidance of personnel responsible for maintenance of Mitsubishi 6D1 series diesel engine, and includes procedures for adjustment and maintenance services.

We earnestly look forward to seeing that this manual is made full use of in order to perform correct service with no wastage.

For more details, please consult your nearest authorized Mitsubishi dealer or distributor.

Kindly note that the specifications and maintenance service figures are subject to change without prior notice in line with improvement which will be effected from time to time in the future.

### Applicable models

6D14    6D14-T  
6D15-T    6D16  
6D16-E    6D16-T  
6D16-TE    6D16-TL  
6D16-TLE

## GROUP INDEX

### HOW TO READ THIS MANUAL

GENERAL .....	<b>00</b>
ENGINE .....	<b>11</b>
LUBRICATION .....	<b>12</b>
FUEL AND ENGINE CONTROL ...	<b>13A</b>

COOLING .....	<b>14</b>
---------------	-----------

INTAKE AND EXHAUST .....	<b>15</b>
--------------------------	-----------

ELECTRICAL SYSTEM .....	<b>54</b>
-------------------------	-----------



---



# HOW TO READ THIS MANUAL

HOW THIS MANUAL IS COMPILED .....	ii
GENERAL EXPLANATION OF THIS MANUAL .....	iii
TERMS AND UNITS .....	vii

# HOW TO READ THIS MANUAL

---

## How This Manual Is Compiled

- This manual is compiled by classifying various systems into certain groups.
- Each group contains specifications; troubleshooting; maintenance service standards;  tightening torque;  lubricant, fluid and sealant;  special tools; and service procedure.
- Page enumeration is independent by every group where first page is always 1.

Group No.	Group denomination	Contents
00	General	General specifications, engine No. and name plate, precautions for maintenance operations, table of standard tightening torques
11	Engine	Engine body
12	Lubrication	Lubrication system
13	Fuel and engine control	Fuel system
14	Cooling	Cooling system
15	Intake and exhaust	Intake and exhaust system, turbocharger, intercooler
21	Clutch	Clutch proper, bearing case
54	Electrical system	Alternator, starter, preheating system, engine start system, automatic stop system
61	Special equipment	Air compressor, pressure governor

# General Explanation of This Manual

## ● Specifications

Particulars relative to maintenance service are made.

## ● Structure and operation

- (1) Regarding conventional equipment, descriptions are made in brief.
- (2) Regarding new equipment, descriptions of system and operating condition are made in detail.

## ● Troubleshooting

Symptoms of troubles and possible causes are described comparatively.

## ● Inspection and adjustment mounted in vehicle

Descriptions are made regarding inspection and adjustment of units mounted in vehicle.

## ● Service procedure

In principle, an explanation is given at the spread title page so that the service procedure can be understood. Servicing points are explained as a supplementary explanation.

# Regarding the design of this manual

## CLUTCH BODY

### Pressure Plate and Lever Assembly

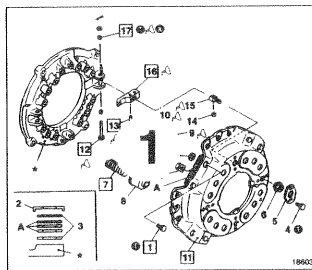

#### ● Disassembly sequence

- 1 Bolt
  - 2 Washer
  - 3 Washer
  - 4 Bolt
  - 5 Lo
  - 6 Su
  - 7 Pre.
  - 8 Pressure spring cap
  - 9 Return spring
  - 10 Release lever plate
  - 11 Clutch cover
  - 12 Release lever pin
  - 13 Support lever pin
  - 14 Bushing
  - 15 Support lever
  - 16 Release lever
  - 17 Bushing
- 2 Pressure plate & lever assembly  
 P 21-12  
 Clutch disc
- \* Flywheel  
 A: Positioning pin (at 2 places)  
 ●: Non-reusable part

1a

#### ● Assembly sequence

- 19 → 17 → 1  
 14 → 15 → 13 → 1  
 Repair kit: clutch release

1b

#### Service standards

Location	Maintenance item	Standard value (Basic diameter in [ ])	Limit	Remedy
1, A	Clearance between strap bolt and strap plate	0.01 to 0.16	0.3	Replace
7	Pressure spring Installed load (installed length 49.1)	8850 N (90.2 kgf)	750 N (76.7 kgf)	Replace
10	Clearance between pin and bushing	2.9 or less	5.0	Replace
10	Release lever	[10] 0.06 to 0.16	0.4	Replace
		53.8 ± 0.7	Mutual difference 0.5 or less	Adjust

#### ● Tightening torque

Location	Parts to be tightened	Tightening torque	Remarks
1	Strap bolt (securing str.)	39 to 59 (4 to 6)	—
4	Bolt (securing lock plate)	5.9 to 7.8 (0.6 to 0.8)	Wet

1. . . . . Illustration for disassembly and assembly or removal and installation: 3-D exploded view of component parts is displayed.
- 1a. . . . . Names of parts show an example of the disassembly (removal) sequence.
- 1b. . . . . When the assembly (installation) sequence differs from the disassembly (removal) sequence, an example of the assembly (installation) sequence is shown.
2. . . . . Service standards are shown collectively, classified by location.
3. . . . . Tightening torques are shown collectively, classified by location.
4. . . . . Points of lubricant, fluid and sealant application are shown collectively, classified by location.
5. . . . . Special tools to be used are shown collectively, classified by location.
6. . . . . When it is considered hard to understand the service procedure, just by the foregoing description, a supplementary description of the service procedure is given.

21

#### △ Lubricants

Location	Points of application	Kind	Quantity
1	Threads of strap bolt	LOCTITE 212	As required
10, 16	Sliding surfaces of relea	Molybdenum disulfide grease	As required
12, 17	Sliding surfaces of supp.	bushing	As required
13, 14	Sliding surfaces of suppo.	Release lever	As required
		Molybdenum disulfide grease (NLGI No. 2 (L scap))	

#### □ Special tools

Location	Tool name and shape	Part No.	Application
11	Clutch installer 	MH061051 01277	Removal and installation of clutch cover
16	Clutch Master Plate 	MH062201 11085	Release lever plate height adjustment

#### ◆ Service procedure

- 1 [A] Clearance between strap bolt and strap plate  
 If the measurement exceeds the limit, replace the defective part.  
 A: Strap plate

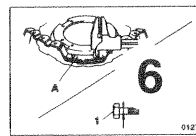

#### 7 Installation of pressure spring

If pressure plate 19 has been reground, insert adjusting washer A corresponding to the amount of grind in the space between the pressure plate and pressure spring 7.

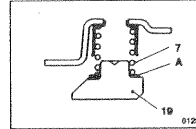

Regrind amount	Type and no. of washers
Less than 1 mm	Not required
1 mm or more to less than 2 mm	One 1.2-mm
2 mm or more to less than 3 mm	Two 1.2-mm or one 2.3-mm

# HOW TO READ THIS MANUAL

## 1. Illustration for disassembly and assembly or removal and installation

This shows that the appropriate service procedure is described in the text.

This shows the key No. of the part. In the text, this No. is referred to uniformly throughout.

This shows an example of the disassembly (removal) sequence.

This shows that the service procedure is described in another section.

☞ P00-00

: shows reference page within the same group.

☞ Gr00

: shows reference group within the same book.

No service procedure is referred to in this section, but the item can be an objective of various procedures.

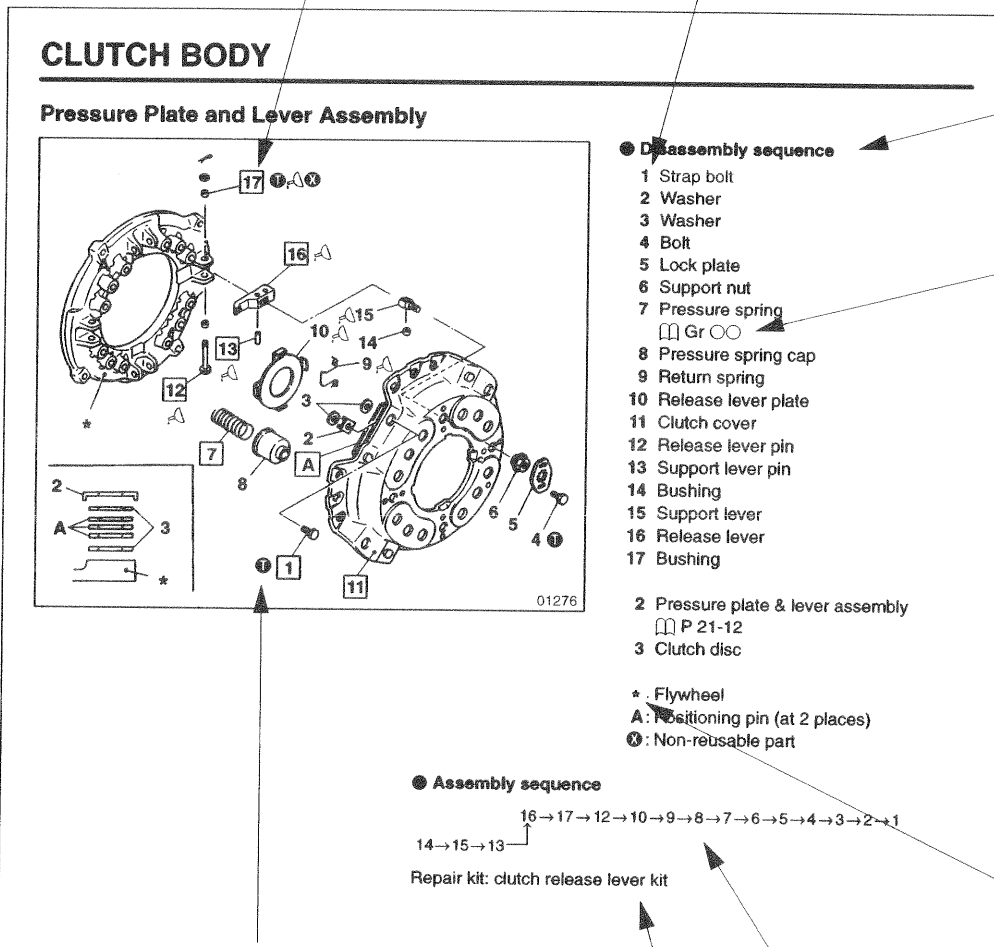

### Meaning of symbols

- ① : shows that the tightening torque is specified.
- ☞ : shows that application of lubricant, fluid or sealant is required.
- ⓧ : shows that the part should not be reused.

This is shown when the assembly (installation) sequence is not the reverse of the disassembly (removal) sequence.

This shows that a repair kit is available.

## 2. Service standards table

Only the relevant service standards are shown.



### Service standards

Unit: mm

Location	Maintenance item	Standard value	Limit	Remedy	
1, 11	Clearance between strap bolt and strap plate	0.01 to 0.16	0.3	Replace	
7	Pressure spring	Installed load (Installed length 49.1)	835 N {85 kgf}	710 N {72.3 kgf}	Replace
		Tilt	2.9 or less	5.0	Replace



This shows the key No. of the relevant part.

## 3. Tightening torque table

This shows specified tightening torque.



### Tightening torque

Unit: N · m {kgf · m}

Location	Parts to be tightened	Tightening torque	Remarks
1	Strap bolts (Strap bolt mounting)	39 to 59 {4 to 6}	—
4	Bolt (Lock plate mounting)	5.9 to 7.8 {0.6 to 0.8}	Wet



This shows the key No. of the relevant part.



This shows that the item is to be tightened wet.

## 4. Lubricant, fluid and sealant table

Only the relevant lubricant, fluid and sealant are shown.



### Lubricant, fluid and sealant

This shows the application point.

Location	Points of application	Kinds	Quantity
1	Thread area of bolt	LOCTITE 272	As required
10, 16	Friction surfaces of release lever plate and release lever	Molybdenum disulfide grease [NLGI No. 2 (Li soap)]	As required



This shows the key No. of the relevant part.



This shows the specified brand.

# HOW TO READ THIS MANUAL

## 5. Special tools table

Only the relevant special tools are shown.

Purpose of special tools is shown.

 Special tools

Unit: mm

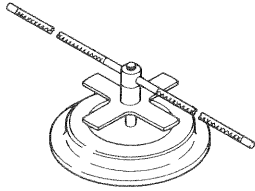
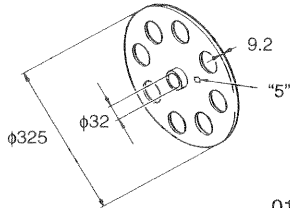
Location	Tool name and shape	Part No.	Application
11	Clutch installer 	MH061051 01277	Removal and installation of clutch cover
16	Master plate 	MH062291 01278	Adjust release lever heights

This shows the key No. of the relevant part.

Quote this number when placing an order for the part.

## 6. Service procedure

This indicates a special service tool.

This shows the key No. of the relevant part.

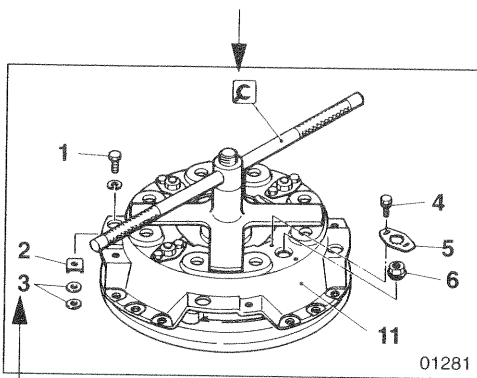

### 11 Removal and installation of clutch cover

- Depress pressure spring 7 using  clutch installer, then remove the following parts:  
Strap bolt 1, washer 2, washer 3, bolt 4, lock plate 5, support nut 6
- Loosen the clutch installer gradually, then remove clutch cover 11 when the pressure spring is fully released.
- For installation, follow the removal sequence in reverse.

The key No. referred to in the text is always the same as the key No. shown in the illustration.

Servicing procedures of disassembly (removal), assembly (installation), inspection, adjustment, etc. are shown collectively.

---

## Terms and Units

The terms and units in this manual are defined as follows.

- This service manual contains important cautionary instructions and supplementary information under the following four headings which identify the nature of the instructions and information:

**DANGER**  \_\_\_\_\_ Precautions that should be taken in handling potentially dangerous substances such as battery fluid and coolant additives.

---

**WARNING**  \_\_\_\_\_ Precautionary instructions, which, if not observed, could result in serious injury or death.

---

**CAUTION**  \_\_\_\_\_ Precautionary instructions, which, if not observed, could result in damage to or destruction of equipment or parts.

---

**NOTE** \_\_\_\_\_ Suggestions or supplementary information for more efficient use of equipment or a better understanding.

### ● Front and rear

The terms “front” is the fan side and “rear” the flywheels side of the engine.

### ● Left and right

The terms “right” and “left” shall be used to indicate the side as viewed from the flywheel side of the engine.

### ● Terms of service standards

#### (1) Standard value

Standard value dimensions in designs indicating: the design dimensions of individual parts, the standard clearance between two parts when assembled, and the standard value for an assembly part, as the case may be.

The figure in [ ] is the basic diameter.

#### (2) Limit

When the value of a part exceeds this, it is no longer serviceable in respect of performance and strength and must be replaced or repaired.

### ● Tightening torque

Excessive or insufficient tightening torque has particular importance in respect of performance. Accordingly, tightening torque is specified in locations that are to be tightened.

Where there is no specified figure for tightening torque, follow the table covering standard tightening torques.

When the item is to be tightened in a wet state, wet is indicated. Where there is no indication, read it as dry, and tighten at specified torque.

# HOW TO READ THIS MANUAL

## ● Unit

Tightening torques and other parameters are given in SI\* units with metric units added in brackets { }.

\*SI: Le Système International d'Unités

Example: 390 N·m {40 kgf·m}

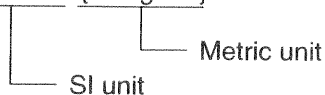

Unit	SI unit {metric unit}	Conversion factor
Force	N {kgf}	9.80665 N {1 kgf}
Moment of force	N·m {kgf·m}	9.80665 N·m {1 kgf·m}
Pressure	Positive pressure	kPa {kgf/cm <sup>2</sup> }
	Vacuum pressure	kPa {mmHg}
		Pa {mmH <sub>2</sub> O}
Volume	dm <sup>3</sup> {L}	1 dm <sup>3</sup> {1 L}
Power	kW {PS}	0.7355kW {1 PS}
Heat quantity	J {kcal}	4186.05 J {1 kcal}
Heat flow	W {kcal/h}	1.16279 W {1 kcal/h}
Angle	°	—
Temperature	°C	—
Electric current	A	—
Voltage	V	—
Resistance	Ω	—
Electric power	W	—

Unit	SI unit	Foot-pound unit	Conversion rate
Force	N (Newton)	lbf	1 N = 0.2248 lbf
Moment of force	N·m	ft.lbs	1 N·m = 0.7375 ft.lbs
Pressure	kPa (kilopascal)	psi	1 kPa = 0.145 psi 1 kPa = 0.2953 in. Hg
Volume	L	gal.	1 L = 0.2642 gal. (U.S.) 1 L = 0.220 gal. (Imp.)
	cm <sup>3</sup>	oz	1 cm <sup>3</sup> = 0.033814 oz (U.S.) 1 cm <sup>3</sup> = 0.035195 oz (Imp.)
	cm <sup>3</sup>	cu.in.	1 cm <sup>3</sup> = 0.061023 cu.in.
Power	kW (kilowatt)	PS	1 kW = 1.3596 PS
Temperature	°C	°F	t°C = (1.8t°C + 32)°F
Mass quantity of matter	kg	lb	1 kg = 2.2046 lb
	g	oz	1 g = 0.035274 oz
Dimension	m	ft.	1 m = 3.2808 ft.
	mm	in.	1 mm = 0.03937 in.

# GROUP 00 GENERAL

GENERAL SPECIFICATIONS ..... 00-2

ENGINE NUMBER AND NAME PLATE ..... 00-3

PRECAUTIONS FOR MAINTENANCE OPERATION ..... 00-4

TABLE OF STANDARD TIGHTENING TORQUES ..... 00-12

# GENERAL SPECIFICATIONS

Item	Specifications								
	6D14	6D14 -T	6D15 -T	6D16	6D16 -E	6D16 -T	6D16 -TE	6D16 -TL	6D16 -TLE
Engine model	6D14	6D14 -T	6D15 -T	6D16	6D16 -E	6D16 -T	6D16 -TE	6D16 -TL	6D16 -TLE
Type	6-cylinder in-line, water-cooled 4-cycle diesel								
Combustion chamber type	Direct injection type								
Valve mechanism	Overhead valve (OHV) type								
Bore × Stroke mm	110 × 115		113 × 115	118 × 115					
Total displacement cc	6557		6919	7545					
Compression ratio	17.5	16		17.5	19	16		17.5	
Empty mass kg*	500	540		500		550		560	

\* Empty mass as measured according to Mitsubishi Motors Corporation standard.

## Engine Outputs Classified By Application

Engine model Application	6D14	6D14-T		6D16	6D16-T	
		Middle-speed specification	High-speed specification		Middle-speed specification	High-speed specification
Intermittent rated output kW (HP)	59 (79)/1500	83 (111)/1500	79 (106)/1500	71 (95)/1500	106 (142)/1500	101 (136)/1500
	70 (94)/1800	98 (132)/1800	95 (127)/1800	85 (114)/1800	123 (165)/1800	121 (163)/1800
	77 (103)/2000	106 (143)/2000	103 (139)/2000	93 (125)/2000	131 (176)/2000	131 (175)/2000
	82 (110)/2200	111 (150)/2200	111 (150)/2200	101 (135)/2200	140 (188)/2200	139 (186)/2200
	87 (117)/2500		120 (161)/2500	111 (149)/2500		147 (197)/2500
	92 (123)/2800		126 (168)/2800	120 (161)/2800		151 (203)/2800
Continuous rated output kW (HP)	53 (72)/1500	75 (101)/1500	72 (96)/1500	65 (87)/1500	96 (129)/1500	92 (123)/1500
	64 (86)/1800	89 (120)/1800	86 (115)/1800	77 (103)/1800	111 (149)/1800	110 (148)/1800
	70 (93)/2000	96 (129)/2000	94 (126)/2000	84 (113)/2000	119 (160)/2000	118 (158)/2000
	74 (99)/2200	101 (136)/2200	101 (136)/2500	93 (125)/2200	127 (170)/2200	125 (168)/2200
	79 (106)/2500		109 (146)/2500	101 (135)/2500		133 (178)/2500
	83 (111)/2800		114 (153)/2800	110 (147)/2800		137 (184)/2800

### NOTE

1. The output (SAE, gross) is corrected to standard ambient conditions based on SAE J1349.
2. The continuous rated output allows 10% (one hour) overload operation.

The serial number for engine is assigned to the respective engine in manufacturing sequence: every engine has its own number. This number is required for incidental inspection of the engine. Please do not fail to mention this number to the dealers when ordering spare parts.

## Engine Number

Engine number 1 is punch-marked on the left of the crankcase.

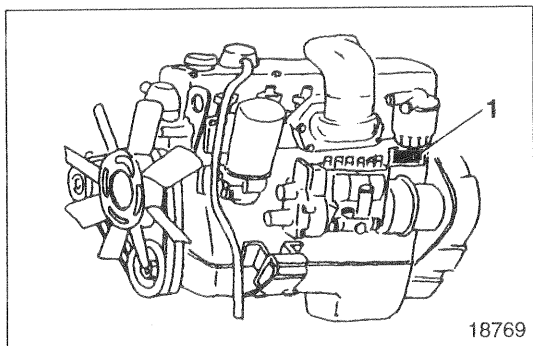

Example: 6D16-□□□□□□

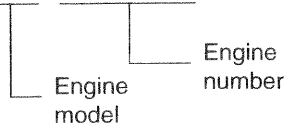

## Name Plate

The name plate is attached to the portion shown in the illustration, and indicate the following items.

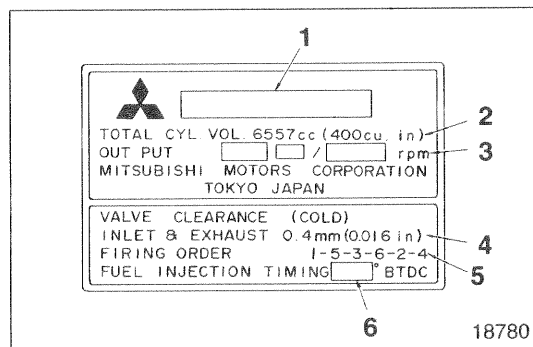
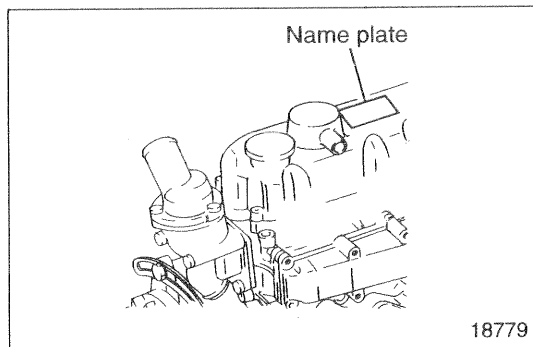

- 1 Engine model
- 2 Total displacement
- 3 Maximum output
- 4 Valve clearance
- 5 Firing order
- 6 Fuel injection timing

# PRECAUTIONS FOR MAINTENANCE OPERATION

In order to determine the condition of the vehicle adequately, attend the vehicle beforehand to find and keep record of the accumulated mileage, operating condition, what the customer's demand is, and other information that may be necessary. Prepare the steps to be taken and perform efficient and wasteless maintenance procedure.



Determine where the fault exists and check for the cause to see whether removal or disassembly of the part is necessary. Then follow the procedure specified by this manual.

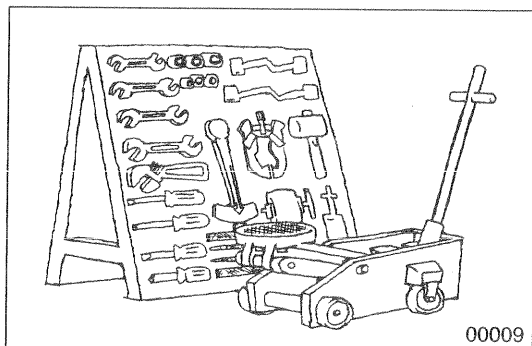

Perform maintenance work at a level area.

Prepare the following.

- Prepare general and special tools necessary for the maintenance work.

**WARNING** ⚠

Do not attempt to use tools other than special tools where use of special tools is specified in this manual. This will avoid injury or damage.

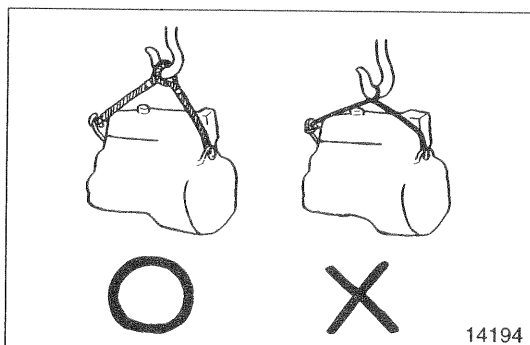

Pay special attention to safety when removing or installing heavy items such as engines, transmissions.

When lifting up heavy items using cables, pay special attention to the following points:

- Check the mass of the item to be lifted and use a cable capable of lifting that mass.

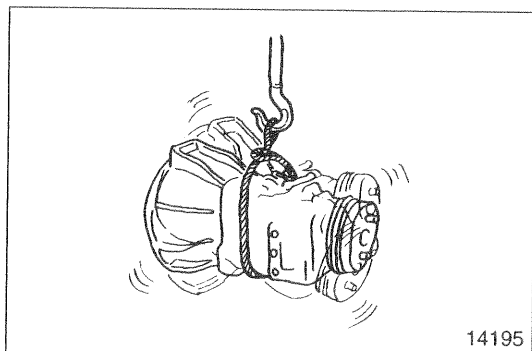

- If you do not have the specified lifting hanger, secure the item using cable taking the point-of-balance of the item into consideration.

- You must work in a position where you will not be injured even if the cable comes undone and the lifted item falls.



00012

Be particularly careful not to work in shoes that have oily soles and are slippery. When working as a team of two or more, arrange signals in advance and keep confirming safety. Be careful not to accidentally bump switches or levers.

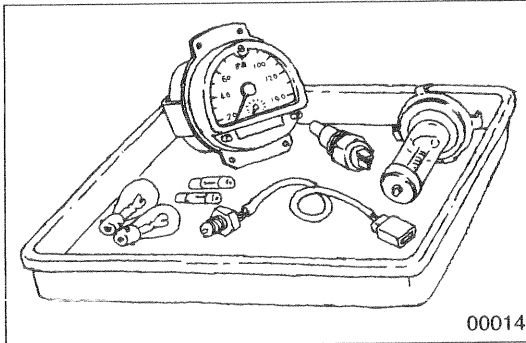

00014

Check for oil leakage before cleaning the area having the fault otherwise you might miss detecting the leakage. Prepare replacement part(s) beforehand.

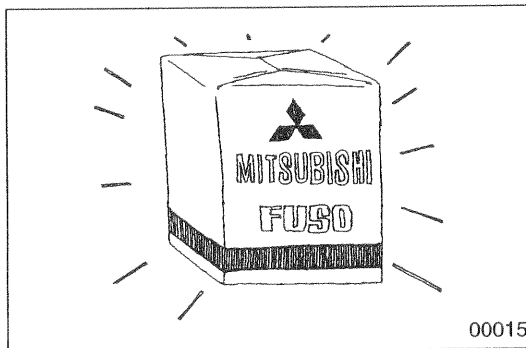

00015

Replace oil seals, packing, O-rings and other rubber parts; gaskets and split pins with new parts whenever any of them has been removed. Use only genuine MITSUBISHI replacement parts.

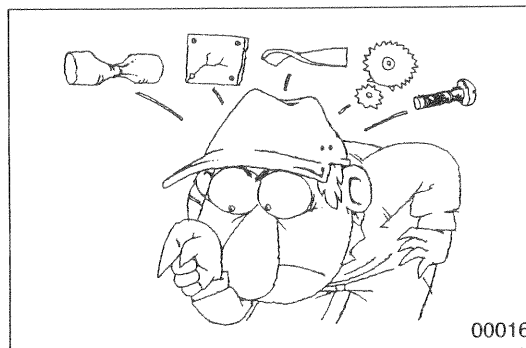

00016

On disassembly, visually inspect all parts for wear and tear, cracks, damage, deformation, degradation, rust, corrosion, smoothness in rotation, fatigue, clogging and any other possible defect.

# PRECAUTIONS FOR MAINTENANCE OPERATION

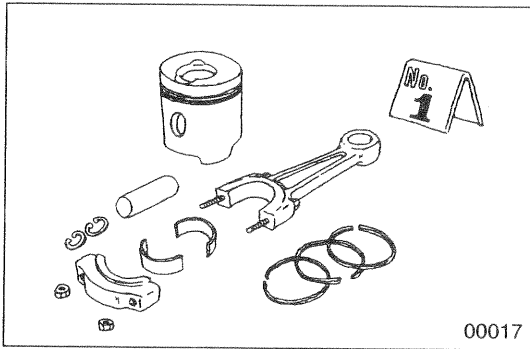

00017

Put alignment marks on part combinations before disassembly and arrange the disassembled parts neatly. This will help avoid mismatching of the parts later.

Put the alignment marks, punch marks, etc. where performance and appearance will not be affected.

Cover the area left open after removal of parts to keep it free from dust.

## CAUTION

- Take care to avoid mixing up numerous parts, similar parts, left and right, etc.
- Keep new parts for replacement and original (removed) parts separate.

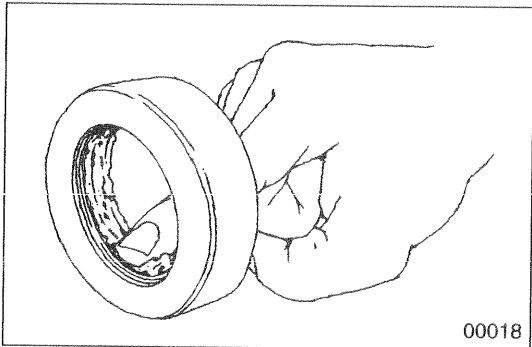

00018

Apply the specified oil or grease to U-packings, oil seals, dust seals and bearings during assembly.

Use only the specified oil, grease, etc. for lubricant, remove the excess immediately after application with a piece of waste, etc.

## CAUTION

When the specified lubricant, fluid and sealant is not available, you may use an equivalent.

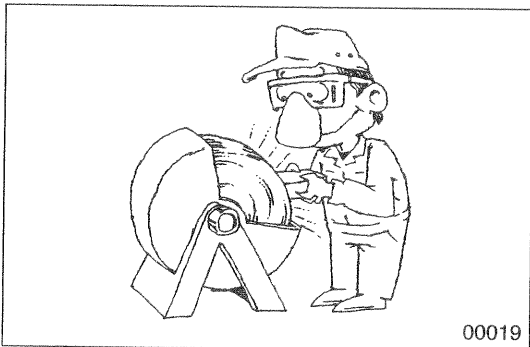

00019

Wear goggles when using a grinder or welder. Pay full attention to safety by wearing gloves when necessary. Watch out for sharp edges, etc. that might injure your hands or fingers.

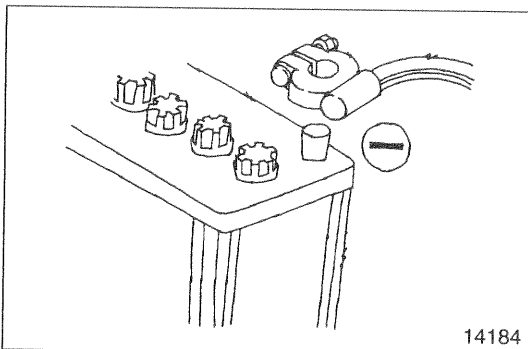

14184

Before carrying out maintenance work on the electric system, disconnect the negative terminals of the batteries to prevent them from short-circuiting and burning-out.

## CAUTION

Be sure to turn starter and lighting switches, etc. off before disconnecting or connecting battery terminals, because the semi-conductors can be damaged.

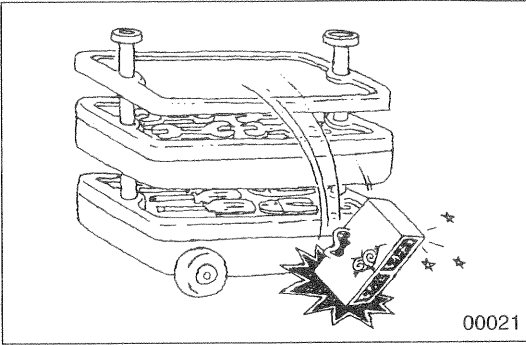

Take care when handling sensors, relays, etc. which are vulnerable to shock and heat. Do not attempt to remove the cover from, or apply paint to, the electronic control unit.

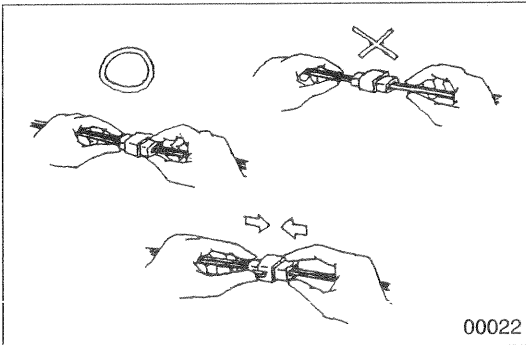

Pull the connector, and not the harness lead, to separate connectors. To separate a lock-type connector, first push toward arrow mark. To reconnect a lock-type connector, press the separated parts until they click together.

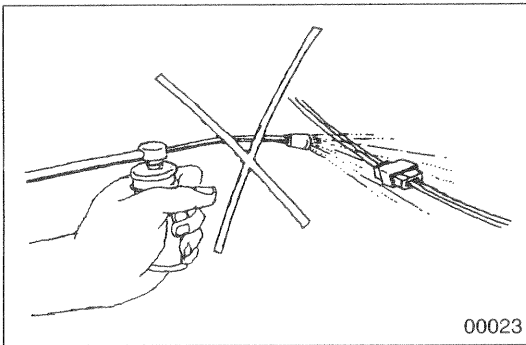

When washing the vehicle, cover the electric system parts and instruments with waterproof material beforehand (Cover with vinyl sheet or the like). Keep water away from harness wire connectors and sensors. If any of them should get wet, wipe them off immediately.

When using an electric welder, such electronic parts that are directly connected to the batteries might be damaged due to the flow of current from the welder that flows through the negative circuit. Parts that have switches might be subject to the same danger if the switches are left on. Therefore, do not fail to observe the following.

- Connect the negative terminal of the welder as near as possible to the area that is to be welded.
- Disconnect the negative terminals of batteries.

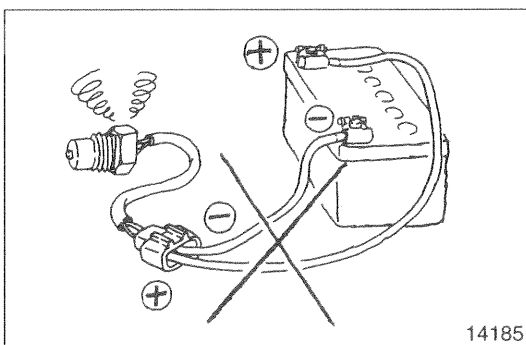

To apply voltage for testing, check that the positive and negative cables are connected properly, then increase voltage gradually from 0 volt. Do not apply voltage higher than the specified value. In particular, pay close attention to the electronic control unit and sensors, since they are not always fed the battery voltage.

# PRECAUTIONS FOR MAINTENANCE OPERATION

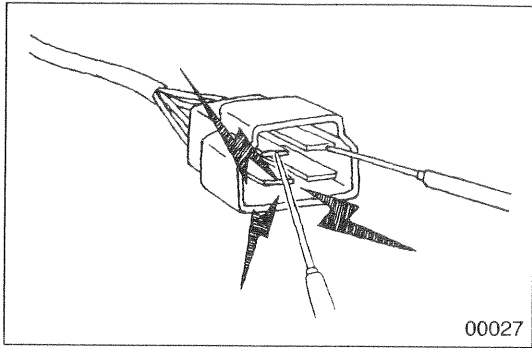

When using testers or the like for continuity tests, be careful not to allow test probes to touch the wrong terminals.

## Measurement Procedures Using Connectors

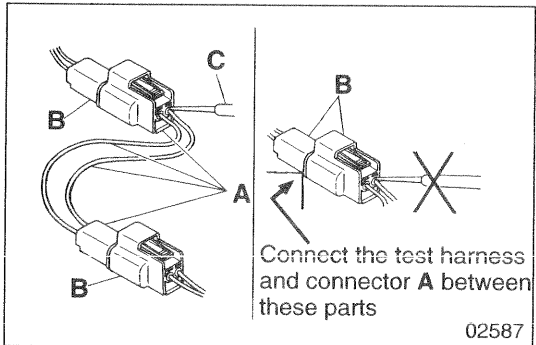

### Test with connectors engaged (continuity through circuit obtained)

<Waterproof connector>

Prepare a test harness and connectors **A**, then connect it between the two parts of harness **B** that is to be tested. Check the circuit by touching test probe **C** to the test connector.

Never insert the test probe from the harness side of the waterproof connection, or waterproof performance might be diminished causing corrosion of the connector.

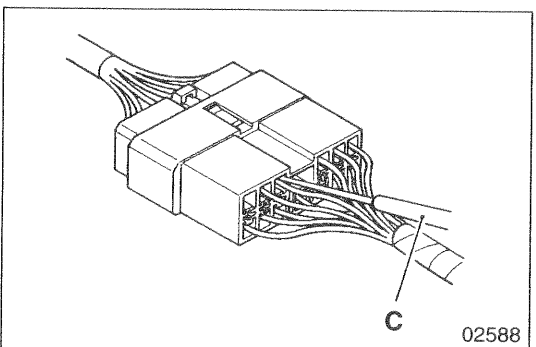

<Non-waterproof connector>

Insert test probe **C** from the harness side of the connector. Where control units, etc. have connectors that are too small to accept the test probe, do not force the test probe into them.

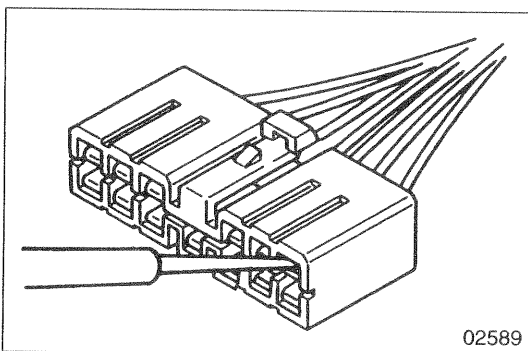

### Test with connectors disengaged

Using female pins

Insert a test probe into a terminal. However, do not force the probe into the terminal, or it will cause a poor contact.

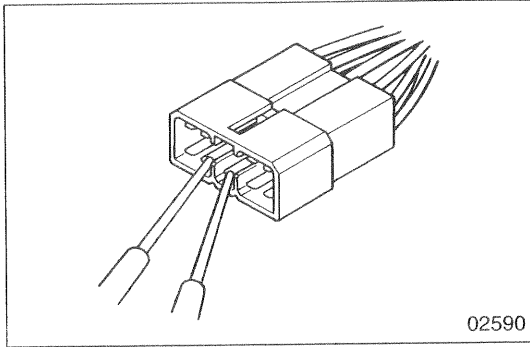

Using male pins  
Touch the pins directly using test probes.

**CAUTION** ⚠️  
Be sure that you do not short circuit the connector pins when you use the test probe because this could damage the internal circuit of the electronic control unit.

## Connector Inspection Procedures

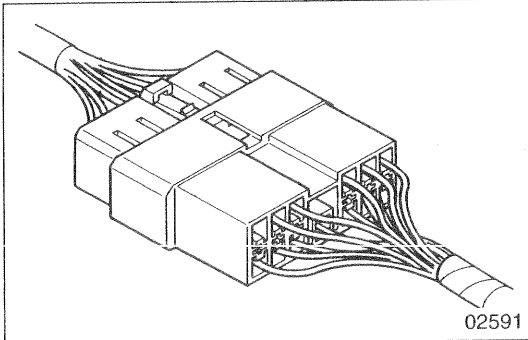

### Visual inspection

Check for loose connection and poor engagement.

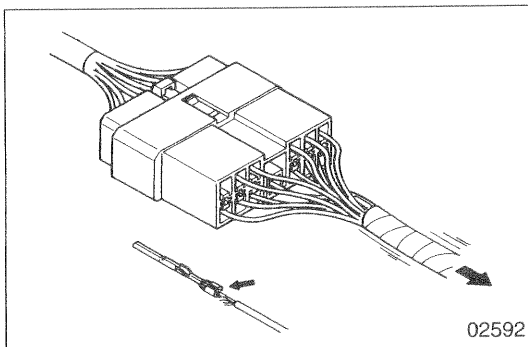

Check if harnesses are broken by pulling gently around the terminals.

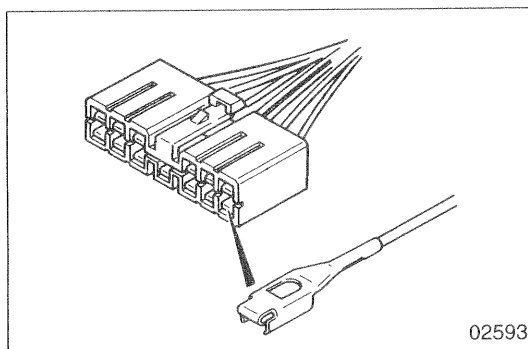

Check for a decrease in contact pressure between the male and female terminals.

Check for poor contact caused by connector pins having fallen out, rusted terminals or foreign particles.

# PRECAUTIONS FOR MAINTENANCE OPERATION

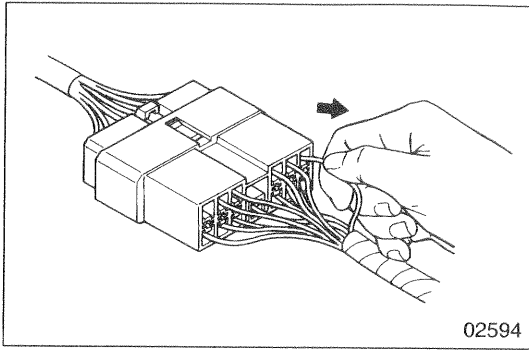

## Connector pin fall out inspection

Damaged connector pin stoppers can cause poor engagement of the terminals (male and female pins) even if the connector body is secured, and might cause some pins to fall out. Check if the pins have fallen out from the connector by pulling each harness gently.

## Inspection Procedures for Blown Fuses

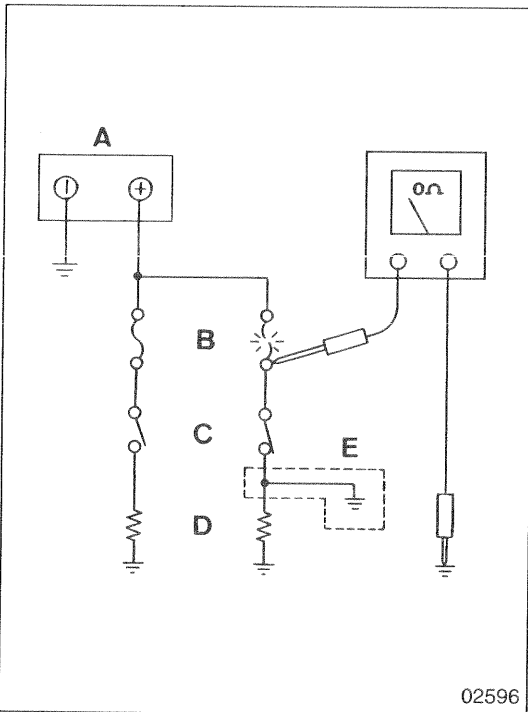

Remove fuse **B** and measure resistance between the loaded side of the fuse and ground.

Turn on all circuit switches (connected to the fuse). If the resistance value reading is approximately 0, a short has occurred between the switch and the loaded point. A value of other than zero may indicate that the fuse was blown by a temporary short but the short is no longer present.

The major causes of a short circuit are as follows:

- Harness stuck onto the vehicle body.
- Harness sheath damaged by friction or heat.
- Water in connectors or circuits.
- Mistakes (accidental short circuits)

- A: Battery
- B: Fuse
- C: Loaded switch
- D: Load
- E: Short circuit

## Precautions for Handling Alternator

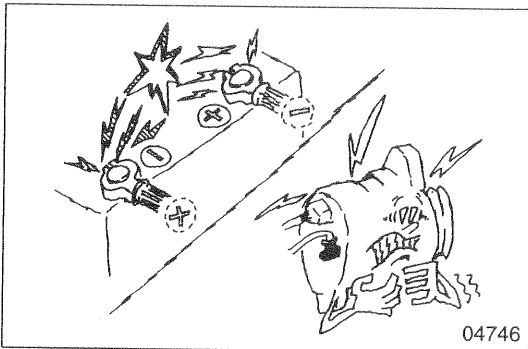

When servicing the alternator, pay attention to the following:

- Do not connect the alternator with battery polarities reversed. If the alternator is connected with reversed polarities, a large current flow from the battery to the alternator occurs, and the diode or regulator might be damaged.

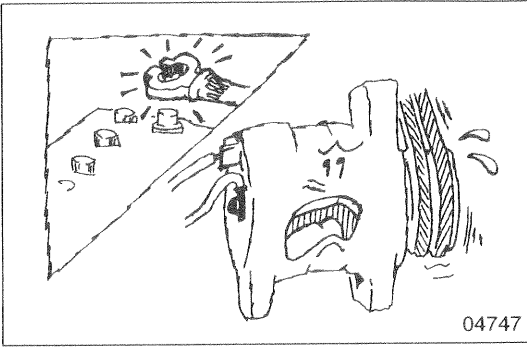

04747

- While the engine is running, do not remove the battery terminals. If the battery terminals are removed at that time, a surge voltage is generated and the diode or regulator might be weakened.

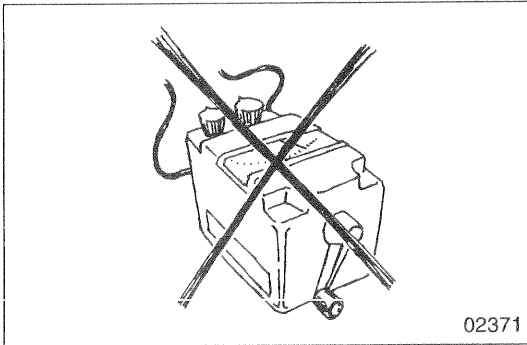

02371

- Do not use a high-voltage tester such as a megger for inspection. If a high-voltage tester is used, the diode or regulator might be destroyed.

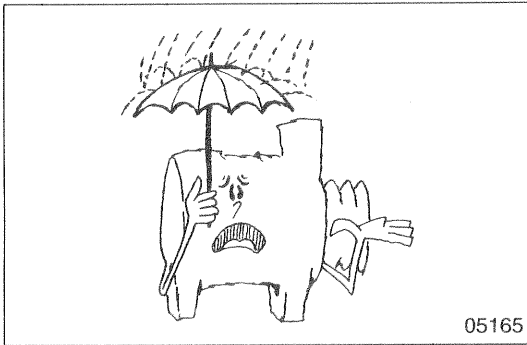

05165

- Do not splash water over the alternator. If water is directly splashed over the alternator, individual components will be short-circuited and might be destroyed.

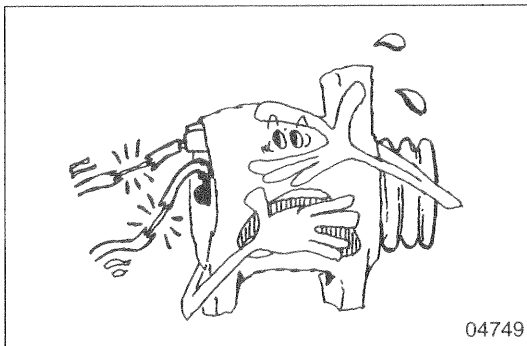

04749

- Do not short-circuit terminal B and terminal L while running the alternator. If the terminals are short-circuited while the alternator is running, the diode trio might be destroyed.

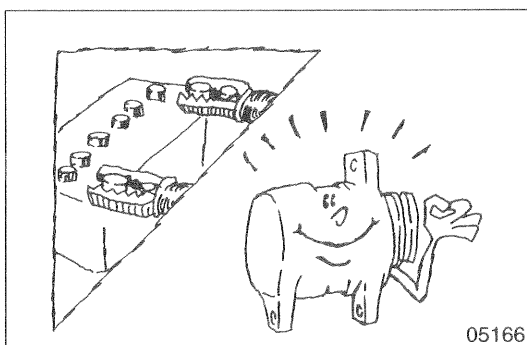

05166





- Disconnect the battery terminals before quick-charging the battery. Quick-charging without disconnecting the battery terminals might damage the diode or regulator.

# TABLE OF STANDARD TIGHTENING TORQUES

- Use specified bolts and nuts and tighten them at specified torques according to the following table, unless otherwise specified.
- Threads and contact seats shall be dry.
- Where there is a difference in strength classification between the nut and bolt (or stud bolt), the torque specified for the bolt shall apply.







## Hex-head Bolt and Stud Bolt

Unit: N · m {kgf · m}

Strength classification	4T		7T		8T	
Representation						
Diameter symbol		(Stud)		(Stud)		(Stud)
<b>M5</b>	2 to 3 {0.2 to 0.3}	-	4 to 6 {0.4 to 0.6}	-	5 to 7 {0.5 to 0.7}	-
<b>M6</b>	4 to 6 {0.4 to 0.6}	-	7 to 11 {0.7 to 1.1}	-	8 to 12 {0.8 to 1.2}	-
<b>M8</b>	9 to 14 {0.9 to 1.4}	-	17 to 26 {1.7 to 2.6}	-	20 to 29 {2.0 to 3.0}	-
<b>M10</b>	19 to 28 {1.9 to 2.8}	18 to 26 {1.8 to 2.7}	36 to 52 {3.5 to 5.5}	33 to 49 {3.3 to 5.0}	45 to 60 {4.5 to 6.0}	41 to 59 {4.3 to 6.9}
<b>M12</b>	35 to 50 {3.4 to 5.0}	31 to 46 {3.1 to 4.7}	70 to 95 {7.0 to 9.5}	65 to 85 {6.5 to 8.5}	85 to 110 {8.5 to 11}	75 to 100 {7.5 to 10}
<b>M14</b>	60 to 85 {6.0 to 8.5}	55 to 75 {5.5 to 7.5}	120 to 160 {12 to 16}	110 to 140 {11 to 14}	130 to 180 {13 to 18}	120 to 160 {12 to 17}
<b>M16</b>	90 to 130 {9.5 to 13}	90 to 120 {9.0 to 12}	180 to 240 {18 to 24}	160 to 220 {16 to 22}	200 to 270 {20 to 27}	190 to 260 {19 to 26}
<b>M18</b>	140 to 190 {14 to 19}	120 to 160 {12 to 16}	260 to 340 {25 to 35}	220 to 290 {22 to 30}	290 to 390 {30 to 40}	260 to 340 {26 to 35}
<b>M20</b>	190 to 260 {19 to 26}	170 to 230 {17 to 23}	350 to 470 {36 to 48}	320 to 420 {32 to 43}	410 to 550 {41 to 56}	370 to 490 {37 to 50}
<b>M22</b>	260 to 340 {26 to 35}	230 to 300 {23 to 31}	470 to 640 {48 to 65}	430 to 570 {43 to 58}	550 to 740 {56 to 75}	490 to 670 {50 to 68}
<b>M24</b>	340 to 450 {34 to 46}	290 to 390 {29 to 40}	630 to 840 {63 to 86}	540 to 730 {55 to 74}	730 to 980 {74 to 100}	630 to 840 {64 to 86}





## Hex-head Flange Bolt

Unit: N · m {kgf · m}

Strength classification	4T		7T		8T	
Representation						
Diameter symbol						
<b>M6</b>	4 to 6 {0.4 to 0.6}	-	8 to 12 {0.8 to 1.2}	-	9 to 14 {0.9 to 1.4}	-
<b>M8</b>	10 to 15 {1.0 to 1.5}	-	19 to 28 {1.9 to 2.8}	-	22 to 32 {2.2 to 3.3}	-
<b>M10</b>	21 to 30 {2.1 to 3.1}	20 to 28 {1.9 to 2.9}	39 to 58 {3.9 to 6.0}	37 to 53 {3.6 to 5.4}	50 to 65 {5.0 to 6.5}	45 to 65 {4.5 to 6.5}
<b>M12</b>	38 to 54 {3.8 to 5.5}	35 to 51 {3.4 to 5.2}	80 to 110 {8.0 to 11}	70 to 95 {7.0 to 9.5}	90 to 120 {9.0 to 12}	85 to 110 {8.5 to 11}

## Hex-head Nut

Unit: N · m { kgf · m }

Strength classification	4T		6T			
Representation						
Diameter symbol	02155					
	Standard screw	Coarse screw	Standard screw	Coarse screw		
<b>M5</b>	2 to 3 {0.2 to 0.3}	—	4 to 6 {0.4 to 0.6}	—		
<b>M6</b>	4 to 6 {0.4 to 0.6}	—	7 to 11 {0.7 to 1.1}	—		
<b>M8</b>	9 to 14 {0.9 to 1.4}	—	17 to 26 {1.7 to 2.6}	—		
<b>M10</b>	19 to 28 {1.9 to 2.8}	18 to 26 {1.8 to 2.7}	36 to 52 {3.5 to 5.5}	33 to 49 {3.3 to 5.0}		
<b>M12</b>	35 to 50 {3.4 to 5.0}	31 to 46 {3.1 to 4.7}	70 to 95 {7.0 to 9.5}	65 to 85 {6.5 to 8.5}		
<b>M14</b>	60 to 85 {6.0 to 8.5}	55 to 75 {5.5 to 7.5}	120 to 160 {12 to 16}	110 to 140 {11 to 14}		
<b>M16</b>	90 to 130 {9.5 to 13}	90 to 120 {9.0 to 12}	180 to 240 {18 to 24}	160 to 220 {16 to 22}		
<b>M18</b>	140 to 190 {14 to 19}	120 to 160 {12 to 16}	260 to 340 {25 to 35}	220 to 290 {22 to 30}		
<b>M20</b>	190 to 260 {19 to 26}	170 to 230 {17 to 23}	350 to 470 {36 to 48}	320 to 420 {32 to 43}		
<b>M22</b>	260 to 340 {26 to 35}	230 to 300 {23 to 31}	470 to 640 {48 to 65}	430 to 570 {43 to 58}		
<b>M24</b>	340 to 450 {34 to 46}	290 to 390 {29 to 40}	630 to 840 {63 to 86}	540 to 730 {55 to 74}		

## Hex-head Flange Nut Unit: N · m { kgf · m }

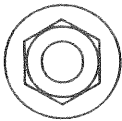
Strength classification	4T	
Representation		
Diameter symbol	02155	
	Standard screw	Coarse screw
<b>M6</b>	4 to 6 {0.4 to 0.6}	—
<b>M8</b>	10 to 15 {1.0 to 1.5}	—
<b>M10</b>	21 to 30 {2.1 to 3.1}	20 to 28 {1.9 to 2.9}
<b>M12</b>	38 to 54 {3.8 to 5.5}	35 to 51 {3.4 to 5.2}

# TABLE OF STANDARD TIGHTENING TORQUES

## Tightening torque for flare nut for general purpose

Unit: N · m {kgf · m}

Pipe diameter	φ4.76 mm	φ6.35 mm	φ8 mm	φ10 mm	φ12 mm	φ15 mm
Tightening torque	17 {1.7}	25 {2.6}	39 {4.0}	59 {6.0}	88 {9.0}	98 {10.0}

## Tightening torque for air piping nylon tube for general purpose {DIN type}

Unit: N · m {kgf · m}

Standard diameter	6 × 1 mm	10 × 1.25 mm	12 × 1.5 mm	15 × 1.5 mm
Tightening torque	$20^{+6}_{-0} \left\{ \begin{array}{l} 2.0^{+0.6} \\ -0 \end{array} \right\}$	$29^{+10}_{-0} \left\{ \begin{array}{l} 3.0^{+1.0} \\ -0 \end{array} \right\}$	$49^{+10}_{-0} \left\{ \begin{array}{l} 5.0^{+1.0} \\ -0 \end{array} \right\}$	$54^{+5}_{-0} \left\{ \begin{array}{l} 5.5^{+1.0} \\ -0 \end{array} \right\}$

## Tightening torque for air piping nylon tube for general purpose {SAE type}

Unit: N · m {kgf · m}

Standard diameter	1/4 in.	3/8 in.	1/2 in.	5/8 in.
Tightening torque	$13^{+4}_{-0} \left\{ \begin{array}{l} 1.3^{+0.4} \\ -0 \end{array} \right\}$	$29^{+5}_{-0} \left\{ \begin{array}{l} 3.0^{+0.5} \\ -0 \end{array} \right\}$	$49^{+5}_{-0} \left\{ \begin{array}{l} 5.0^{+0.5} \\ -0 \end{array} \right\}$	$64^{+5}_{-0} \left\{ \begin{array}{l} 6.5^{+0.5} \\ -0 \end{array} \right\}$

# GROUP 11 ENGINE

<b>SPECIFICATIONS .....</b>	<b>11-2</b>
<b>STRUCTURE AND OPERATION</b>	
1. Cylinder Head and Crankcase .....	11-3
2. Valve Mechanism .....	11-4
3. Connecting Rods .....	11-4
4. Pistons .....	11-5
5. Timing Gears .....	11-5
6. Flywheel .....	11-6
7. Flywheel PTO .....	11-6
<b>TROUBLESHOOTING .....</b>	<b>11-7</b>
<b>ON-VEHICLE INSPECTION AND ADJUSTMENT</b>	
1. Measuring Compression Pressure .....	11-8
2. Inspecting and Adjusting Valve Clearances .....	11-10
<b>CYLINDER HEAD AND VALVE MECHANISM .....</b>	<b>11-12</b>
<b>PISTONS, CONNECTING RODS, AND CYLINDER LINERS ...</b>	<b>11-28</b>
<b>FLYWHEEL PTO .....</b>	<b>11-44</b>
<b>FLYWHEEL .....</b>	<b>11-48</b>
<b>TIMING GEARS .....</b>	<b>11-54</b>
<b>CAMSHAFT .....</b>	<b>11-64</b>
<b>CRANKSHAFT AND CRANKCASE .....</b>	<b>11-72</b>

# SPECIFICATIONS

Item	Specifications						
Engine model	6D14	6D14-T	6D15-T	6D16	6D16-E	6D16-T 6D16-TE 6D16-TL	6D16-TLE
Type	6-cylinder, in-line, water-cooled, 4-cycle diesel						
Combustion chamber type	Direct injection						
Valve mechanism	Overhead valve						
Cylinder bore × stroke	mm	φ110 × 115	φ113 × 115	φ118 × 115			
Total displacement	cc	6557	6919	7545			
Compression ratio		17.5	16.0	17.5	19	16.0	17.5

## 1. Cylinder Head and Crankcase

<Engines with wet type cylinder liners: 6D14, 14-T, 15-T>

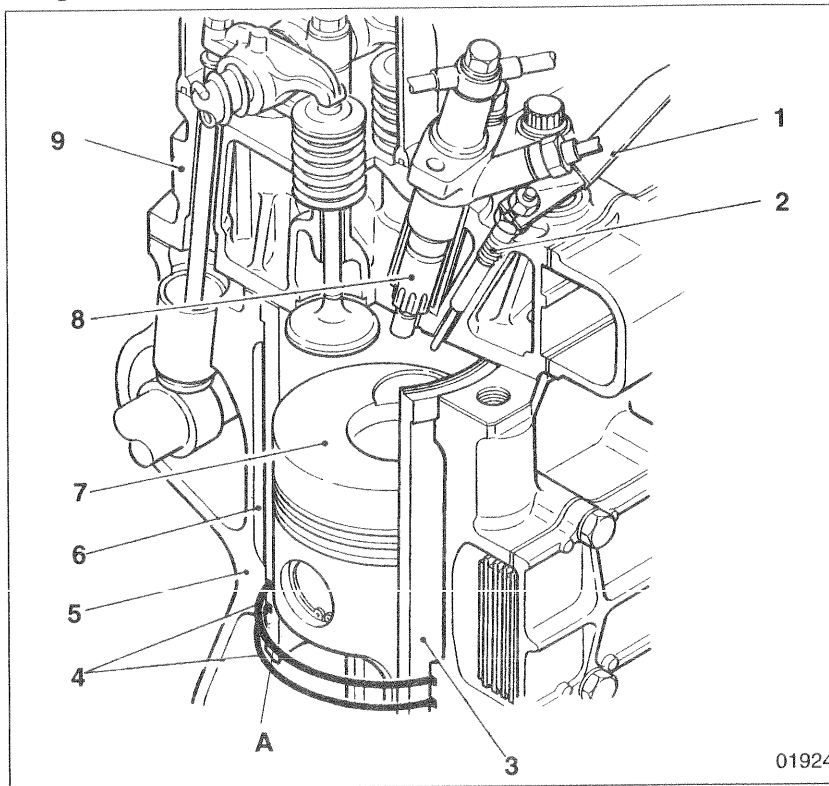

- 1 Connecting plate
- 2 Glow plug
- 3 Cylinder liner
- 4 O-ring
- 5 Crankcase
- 6 Water jacket
- 7 Piston
- 8 Injection nozzle
- 9 Cylinder head

A: Cylinder liner size mark: A, B, C

- The cylinder liners 3 are a removable wet type liners. They are press-fitted into the top of the crankcase 5 and the bottom of the water jacket 6.
- The O-rings 4 are provided to prevent the ingress of coolant.
- The cylinder liners 3 and pistons 7 have size marks. The liner and piston that are paired should be of the same size mark.

<Engines with dry type cylinder liner: 6D15-T, 16, 16-E, 16-T, 16-TE, 16-TL, 16-TLE>

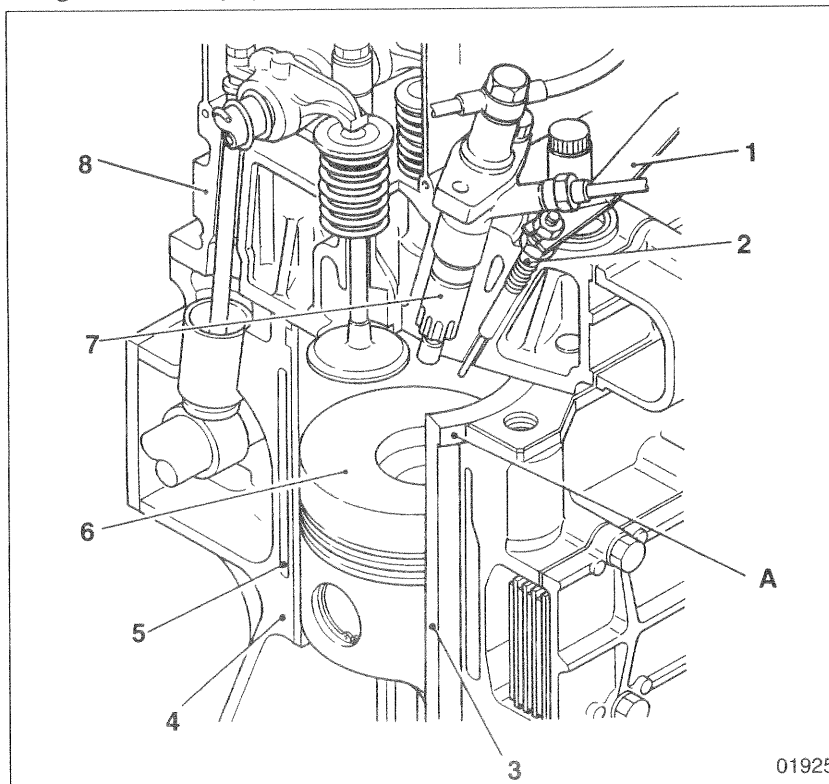

- 1 Connecting plate
- 2 Glow plug
- 3 Cylinder liner
- 4 Crankcase
- 5 Water jacket
- 6 Piston
- 7 Injection nozzle
- 8 Cylinder head

A: Cylinder liner size mark  
 Outer diameter mark: 1, 2, 3  
 Inner diameter mark: A, B

- The cylinder liners 3 are a dry type liners that are easier to remove than wet liners. Liners are press-fitted into the crankcase 4.
- The cylinder liners 3, crankcase 4, and pistons 6 have size marks. They should be combined as specified according to the size marks. P.11-28

# STRUCTURE AND OPERATION

## 2. Valve Mechanism

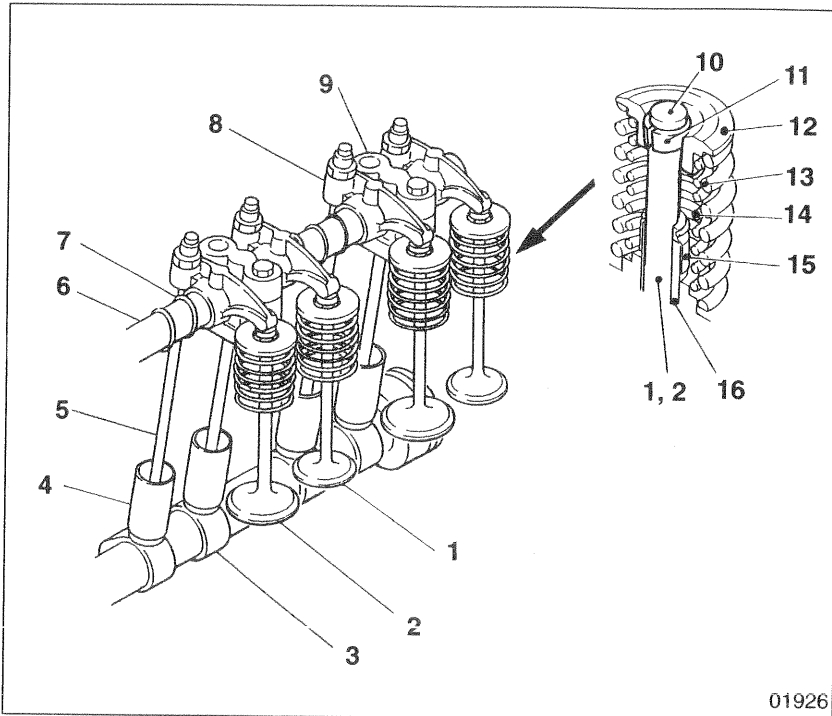

01926

- 1 Exhaust valve
- 2 Inlet valve
- 3 Camshaft
- 4 Tappet
- 5 Push rod
- 6 Rocker shaft
- 7 Rocker shaft spring
- 8 Rocker
- 9 Rocker shaft bracket
- 10 Valve cap
- 11 Valve cotter
- 12 Upper retainer
- 13 Outer valve spring
- 14 Inner valve spring
- 15 Valve stem seal
- 16 Valve guide

- The valve stem seals **15** are fitted onto the valves **1, 2** to control the amount of lubricant flowing onto the sliding surfaces of the valves **1, 2** and valve guides **16**.
- The valve springs **13, 14** are unevenly pitched to prevent abnormal vibration at high speeds. To prevent the inner and outer springs from meshing with each other, the springs are wound in opposite directions.
- To facilitate removal and reinstallation of the camshaft from the rear end of the crankcase, the diameter of each bushing is smaller toward the front of the engine.

## 3. Connecting Rods

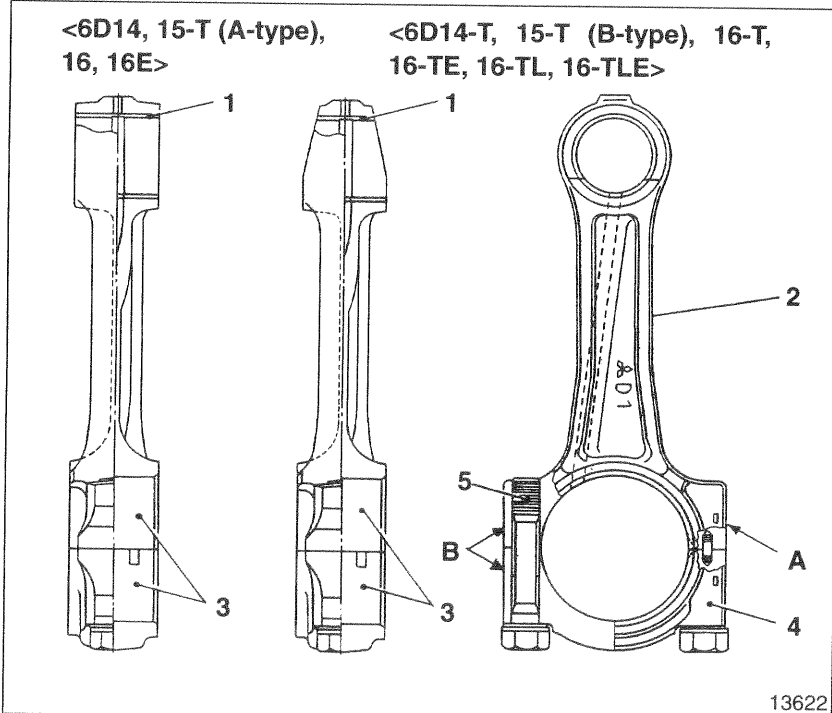

13622

- 1 Connecting rod bushing
- 2 Connecting rod
- 3 Connecting rod bearing
- 4 Connecting rod cap
- 5 Connecting rod bolt

- A:** Alignment mark  
**B:** Weight mark stamp  
 (A, B, C, D, E, F, G, H, I, V, W, X, Y, Z:  
 <except 6D16-TLE>)  
 (A, B, C, D, E, F: <6D16-TLE>)

### 4. Pistons

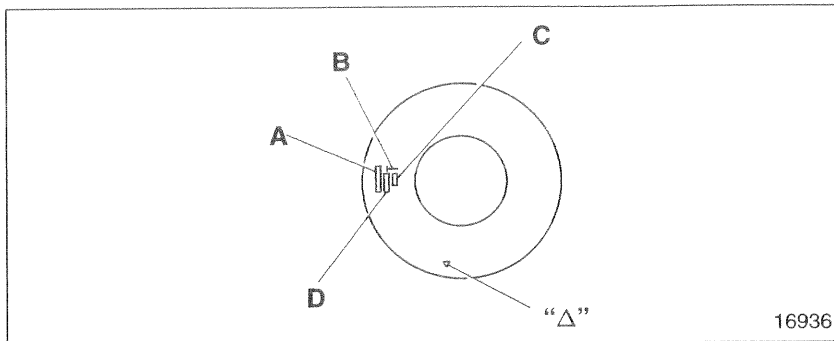

- A: Part number
- B: "T" mark <6D14-T, 15-T, 16-T, 16-TE, 16-TL, 16-TLE>
- C: Size mark (A, B, C: <6D14, 14-T, 15-T>)  
(A, B: <6D16, 16-E, 16-T, 16-TE, 16-TL, 16-TLE>)
- D: Weight mark
- △: Front mark

16936

### 5. Timing Gears

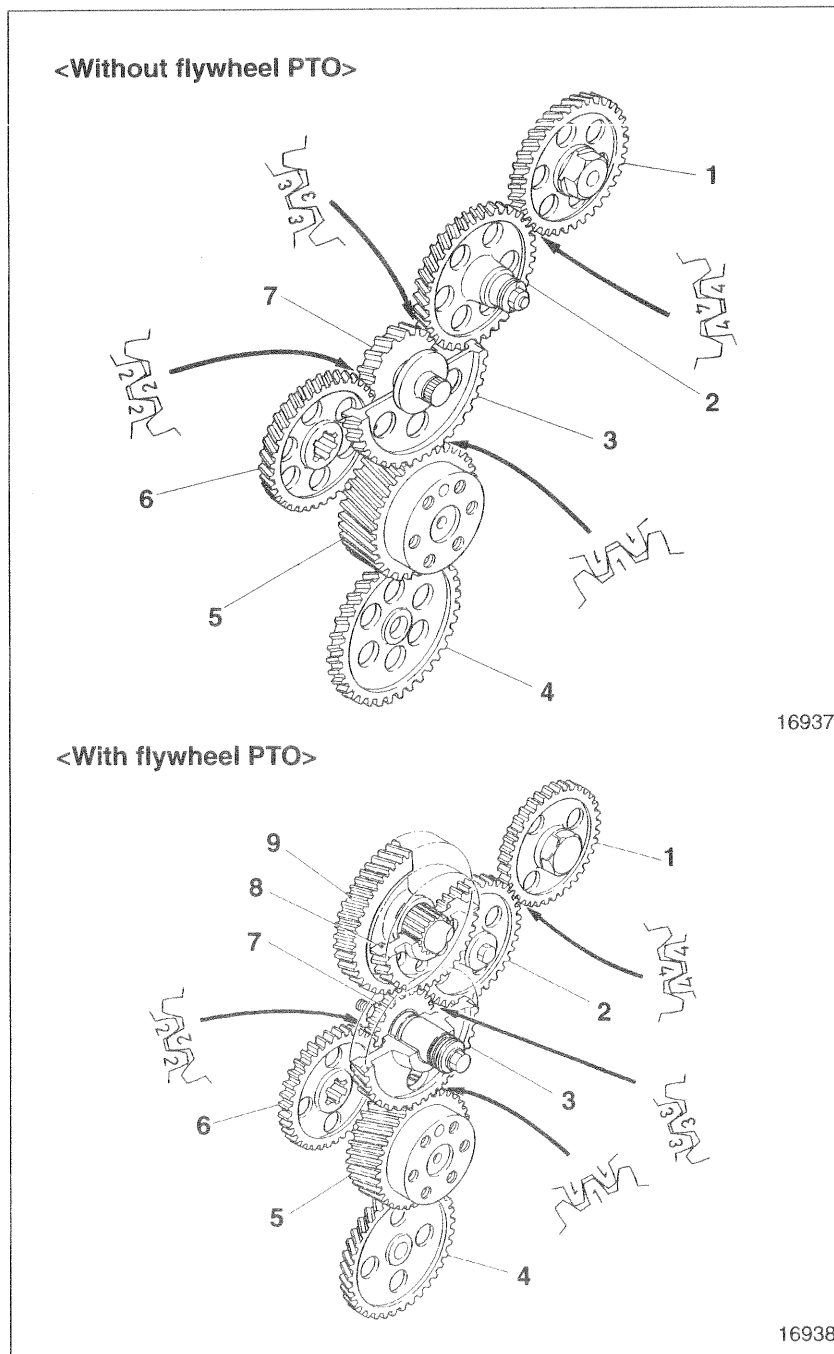

- 1 Camshaft gear
- 2 No. 2 idler gear
- 3 No. 1 idler gear
- 4 Oil pump gear
- 5 Crankshaft gear
- 6 Air compressor drive gear or injection pump drive gear
- 7 No. 1 idler gear
- 8 PTO idler gear  
<models with flywheel PTO>
- 9 PTO idler gear  
<models with flywheel PTO>

Each gear is stamped with a timing gear alignment mark ("1", "2", "3", or "4") to facilitate reassembly.

16937

16938

# STRUCTURE AND OPERATION

## 6. Flywheel

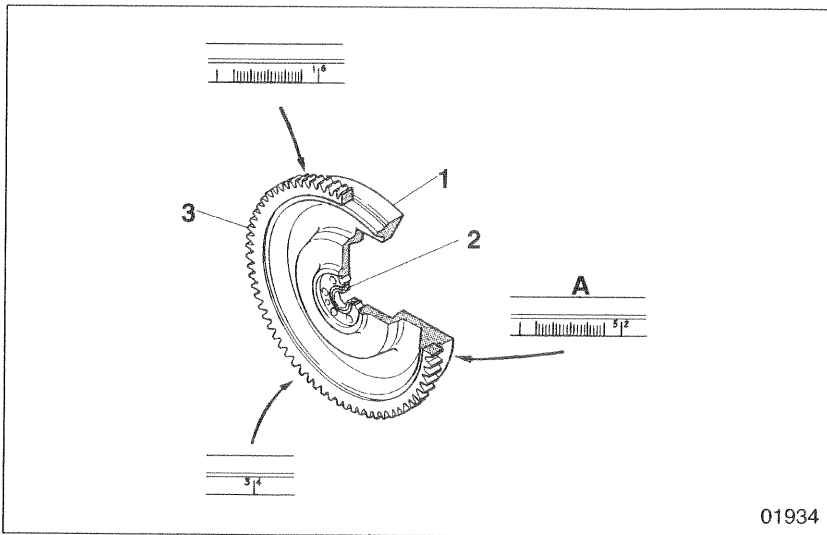

- 1 Flywheel
- 2 Pilot bearing
- 3 Ring gear

A: Angle scale, cylinder number

## 7. Flywheel PTO

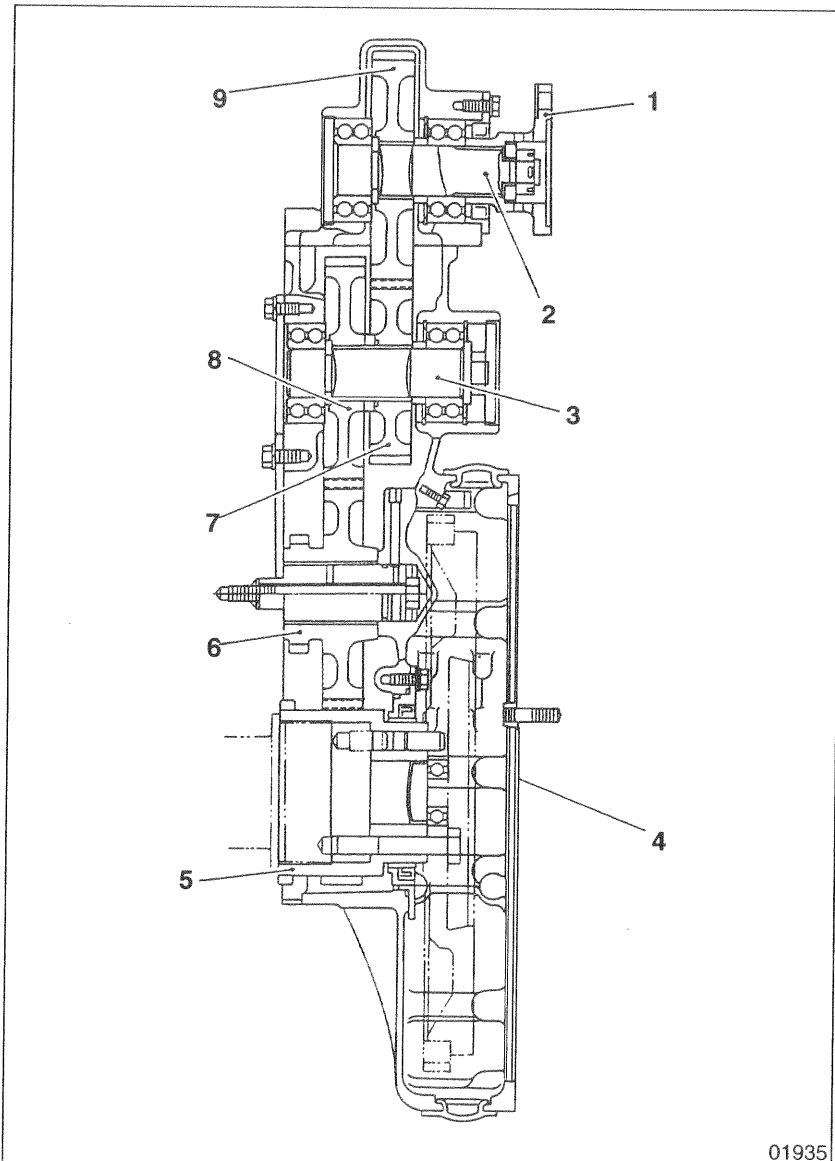

- 1 Flange
- 2 PTO shaft
- 3 PTO idler shaft
- 4 Flywheel housing
- 5 Crankshaft gear
- 6 No. 1 idler gear
- 7 PTO idler gear
- 8 PTO idler gear
- 9 PTO gear

The flywheel PTO is fitted onto the top of the flywheel housing 4 and is driven by the crankshaft gear 5.

Symptoms			Remarks
	Low power output	Abnormal engine noise	
Possible causes			
Incorrect oil viscosity	<input type="radio"/>		Gr 12
Incorrect/defective fuel	<input type="radio"/>		Gr 13
Incorrect valve clearance	<input type="radio"/>	<input type="radio"/>	
Defective cylinder head gasket	<input type="radio"/>	<input type="radio"/>	
Worn valve/valve seat, and carbon deposits	<input type="radio"/>	<input type="radio"/>	
Weakened valve spring	<input type="radio"/>	<input type="radio"/>	
Worn/damaged piston ring(s)	<input type="radio"/>	<input type="radio"/>	
Worn/damaged piston ring groove(s)	<input type="radio"/>	<input type="radio"/>	
Incorrect injection timing	<input type="radio"/>	<input type="radio"/>	Gr 13
Defective injection pump	<input type="radio"/>	<input type="radio"/>	Gr 13
Defective cooling system	<input type="radio"/>		Gr 14
Defective injection nozzle(s)	<input type="radio"/>	<input type="radio"/>	Gr 13
Air trapped in fuel system	<input type="radio"/>		Gr 13
Clogged air cleaner	<input type="radio"/>		Gr 15
Clogged muffler	<input type="radio"/>		Gr 15
Defective turbocharger	<input type="radio"/>	<input type="radio"/>	Gr 15
Incorrectly fitted pipe(s)/hose(s)		<input type="radio"/>	Gr 13
Injection pump, alternator, or other auxiliary device(s) defective/incorrectly fitted		<input type="radio"/>	Gr 13, 54
Loose/damaged V-belt		<input type="radio"/>	Gr 14
Incorrectly fitted crankshaft pulley		<input type="radio"/>	
Defective air cleaner or muffler		<input type="radio"/>	Gr 15
Defective valve spring(s)		<input type="radio"/>	
Defective rocker shaft and bracket		<input type="radio"/>	
Incorrect lubrication of rocker shaft bracket		<input type="radio"/>	
Incorrect backlash in timing gears		<input type="radio"/>	
Incorrect lubrication of timing gear peripheries and idler shafts		<input type="radio"/>	
Worn connecting rod small end bushing and piston pin		<input type="radio"/>	
Worn/damaged crankshaft pin and connecting rod big end bearing		<input type="radio"/>	
Worn/damaged crankshaft journal and main bearing		<input type="radio"/>	
Excessive end play in crankshaft and camshaft		<input type="radio"/>	
Worn tappet(s) and camshaft		<input type="radio"/>	

# ON-VEHICLE INSPECTION AND ADJUSTMENT

## 1. Measuring Compression Pressure

### Service standards

Location	Maintenance item		Standard value	Limit	Remedy	
—	Compression pressure	Each cylinder (at 200 rpm)	Except 6D16-E	2550 kPa {26 kgf/cm <sup>2</sup> }	1960 kPa {20 kgf/cm <sup>2</sup> }	Inspect
			6D16-E	2940 kPa {30 kgf/cm <sup>2</sup> }		
		Cylinder-to-cylinder pressure difference		—	390 kPa {4 kgf/cm <sup>2</sup> }	Inspect

### Special tools

Unit: mm

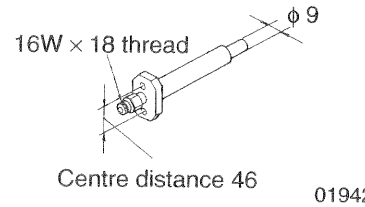
Location	Tool name and shape	Part No.	Application
—	Compression Gauge Adapter  16W × 18 thread φ9 Centre distance 46 01942	MH061461	Measuring compression pressure

Reductions in compression pressure should be used as a guide in determining the timing of engine overhauls. Take measurements regularly and keep track of changes; an overview of pressure variations can be useful in fault diagnosis.

During the engine's run-in period and after parts have been replaced, the compression pressure will increase slightly as piston rings, valve seats, and other parts fit snugly in position. The pressure will then normalize as parts wear.

- Before inspections, check that the engine oil, starter, and battery are normal.
- Warm up the engine until the coolant temperature reaches 75 to 85°C.
- Turn off all lights and auxiliary devices.
- To prevent injection of fuel while cranking the engine by the starter, perform the following steps.
  - Set the stop lever of the injection pump governor to the stop position. <Mechanical governor>
  - Remove fuse 1 shown in the diagram below. For the terminal arrangement of the engine ECU, refer to Gr. 13E. <Electronic governor>

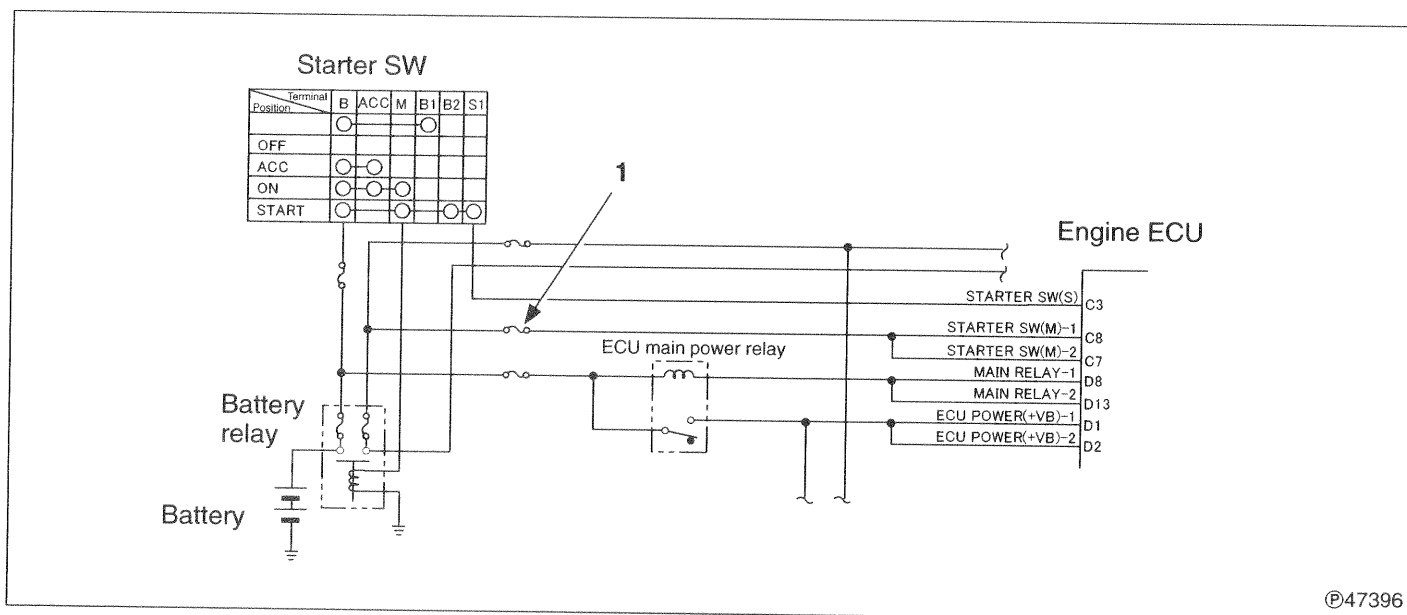

©47396

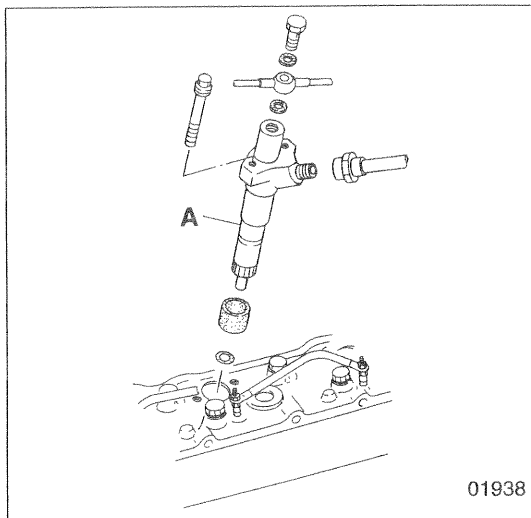

- Remove the injection nozzle **A**.

📖 Gr 13A

**CAUTION** ⚠️

Cover the mounting holes and injection pipes to prevent the entry of dust and dirt.

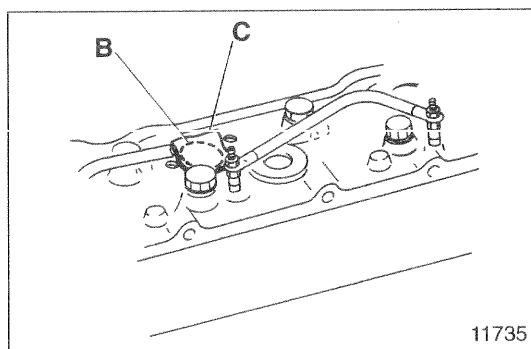

- Cover the injection nozzle mounting hole **B** with a cloth **C**. Then, turn the engine over with the starter and check that no foreign matter adheres to the cloth.

**WARNING** ⚠️

If any cylinder is cracked, coolant, engine oil, and fuel will enter the cylinder through the crack. When the engine is turned over, these substances will spray out of the nozzle mounting hole **B** at a high temperature. For safety, move away from the nozzle mounting hole before turning over the engine.

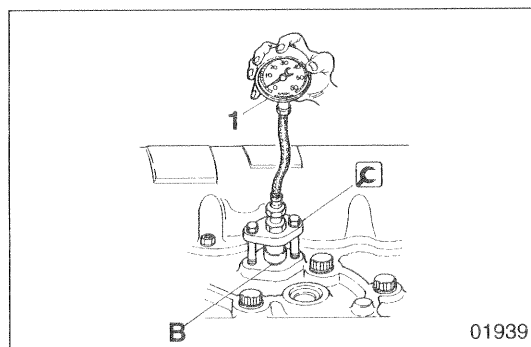

- Fit the  Compression Gauge Adapter onto an injection nozzle mounting hole **B** together with a nozzle gasket. Then, connect the compression gauge **1**.
- Turn the engine over and measure the compression pressure.
- Measure the compression pressure in every cylinder and determine the pressure differences between cylinders.
- If any compression pressure or cylinder-to-cylinder pressure difference exceeds the specified limit, pour a little engine oil into the cylinder via the injection nozzle mounting hole **B** then take the measurement again.
  - If the compression pressure increases, there may be wear or damage on piston rings and inner surfaces of cylinders.
  - If the compression pressure does not increase, valves may be seized or incorrectly seated, or the cylinder head gasket may be defective.

# ON-VEHICLE INSPECTION AND ADJUSTMENT

## 2. Inspecting and Adjusting Valve Clearances

### Service standards

Unit: mm

Location	Maintenance item	Standard value	Limit	Remedy
—	Valve clearance (when cold)	0.4	—	Adjust

### Tightening torques

Unit: N·m {kgf·m}

Location	Parts to be tightened	Tightening torque	Remarks
2, 6	Rocker arm adjusting screw lock nut	34 {3.5}	—

Valve clearances should be checked and adjusted when the engine is cold.

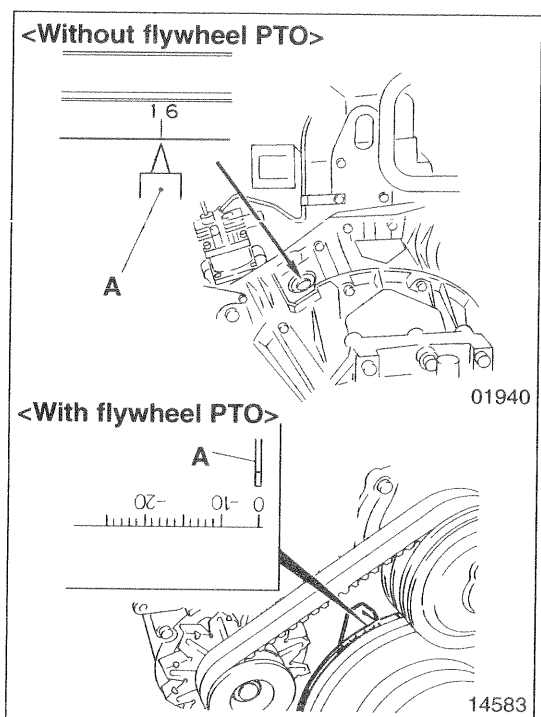

[Inspection]

- Bring piston No. 1 or piston No. 6 to the top-dead-centre (TDC) position of its compression stroke. To do this, crank the engine until the “1.6” mark inscribed on the flywheel is aligned with the pointer **A** in the flywheel housing inspection window. (If the engine has a flywheel PTO, align the pointer **A** with the “0” mark inscribed on the torsional damper.)

#### NOTE

Pistons whose push rods are not pushing up their rockers are at top-dead-centre (TDC) of their compression strokes.

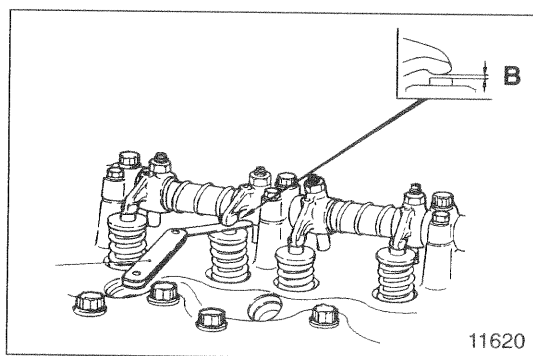

- When piston No. 1 or piston No. 6 is at the TDC position of its compression stroke, measure the clearance **B** of every valve marked “○” in the following table.

Piston No.	1		2		3		4		5		6	
	In.	Ex.	In.	Ex.	In.	Ex.	In.	Ex.	In.	Ex.	In.	Ex.
No. 1 piston at TDC of compression stroke	○	○	○	×	×	○	○	×	×	○	×	×
No. 6 piston at TDC of compression stroke	×	×	×	○	○	×	×	○	○	×	○	○

#### NOTE

To measure the clearance, insert a feeler gauge 1. The gauge should be able to move in the gap, albeit not loosely. Accurate measurements cannot be taken if the gauge moves loosely in the gap.

- If any measurement is out of specification, make adjustments as follows:

[Adjustment]

- To adjust the valve clearance **B**, loosen the lock nut **2** and turn the adjusting screw **3** until the feeler gauge **1** moves more stiffly in the gap.
- After adjusting the clearance, tighten the lock nut **2**. At this time, use a screwdriver **C** to stop the adjusting screw **3** from turning. Next, insert the feeler gauge **1** once more to confirm that the clearance **B** is correct.

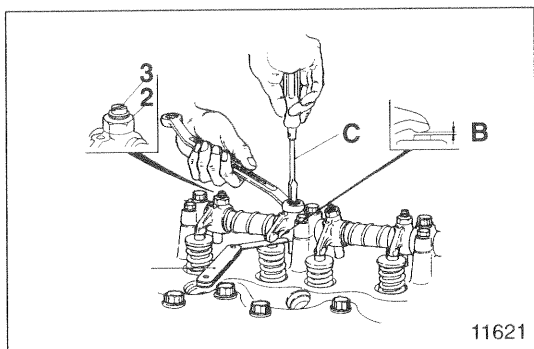

# CYLINDER HEAD AND VALVE MECHANISM

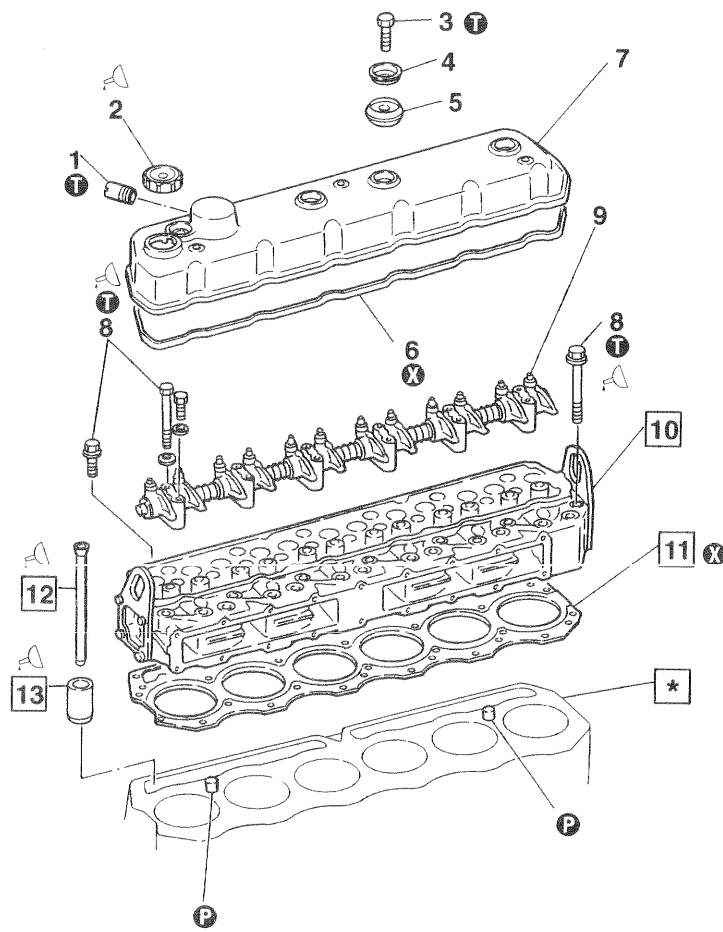

04134

## ● Disassembly sequence

- |                       |  |                      |
|-----------------------|--|----------------------|
| 1 Joint               | 8 Cylinder head bolt                           | 12 Push rod          |
| 2 Oil filler cap      | 9 Rocker and bracket assembly<br>P.11-16       | 13 Tappet            |
| 3 Bolt                | 10 Cylinder head and valve assembly<br>P.11-20 | *: Crankcase P.11-72 |
| 4 Plate               | 11 Cylinder head gasket                        | P: Locating pin      |
| 5 Rubber              |  | X: Non-reusable part |
| 6 Rocker cover gasket |  |                      |
| 7 Rocker cover        |  |                      |

## ● Assembly sequence

Follow the disassembly sequence in reverse.

## Service standards

Unit: mm

Location	Maintenance item	Standard value (Basic diameter in [ ])	Limit	Remedy	
12	Push rod runout	—	0.4	Replace	
13, *	Tappet-to-crankcase clearance	6D14, 14-T, 15-T, 16, 16-E	[31] 0.06 to 0.10	0.2	Replace tappet
		6D16-T, 16-TE, 16-TL, 16-TLE	[31] 0.03 to 0.07		

## ① Tightening torques

Unit: N·m {kgf·m}

Location	Parts to be tightened	Tightening torque	Remarks	
1	Joint	29 {3.0}	—	
3	Rocker cover bolt	3.9 {0.4}	—	
8	Cylinder head bolt (installation of rocker and bracket assembly and cylinder head and valve assembly)	M14 bolt	78 {8} + 180°	<ul style="list-style-type: none"> <li>Wet</li> <li>Can be reused up to 3 times</li> </ul>
		M10 bolt	17 {1.75} + 34 {3.5}	

## 🔧 Lubricant

Location	Points of application	Specified lubricant	Quantity
2	Rubber seal of oil filler cap	Engine oil	As required
8	Threads of cylinder head bolts	Engine oil	As required
12	Both ends of push rods	Engine oil	As required
13	Outer surfaces of tappets	Engine oil	As required

## 🔧 Special tools

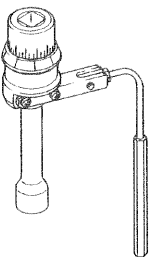
Location	Tool name and shape	Part No.	Application
10	Socket Wrench 	MH063388	Tightening cylinder head bolts (M14 bolt only)

01984

## ◆ Service procedure

## ⑩ Cylinder head and valve assembly

[Removal]

- Before loosening the cylinder head bolts **8**, loosen the adjusting screw **C** on every rocker **A** that is compressing its valve spring **B**.

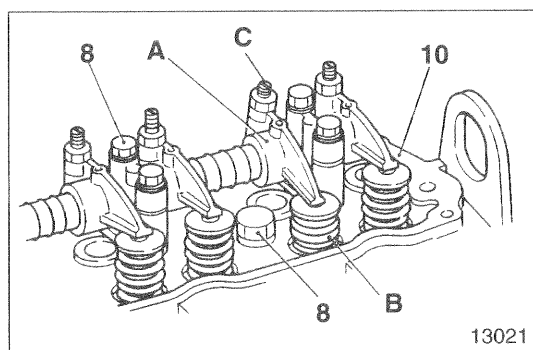

# CYLINDER HEAD AND VALVE MECHANISM

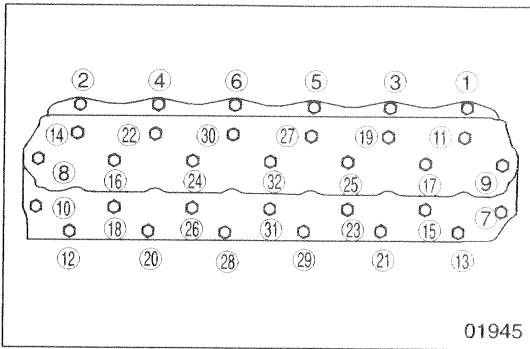

- Loosen and remove the cylinder head bolts **8** in the sequence shown. Each cylinder head bolt should be loosened a little at a time.

[Installation]

## CAUTION

Before fitting any cylinder head bolt **8**, check the punch marks **A** on its head. Do not use the bolt if there are more than two punch marks. The punch marks indicate the number of times each bolt has been tightened using the plastic area tightening method. Any bolt that already has three punch marks must be replaced.

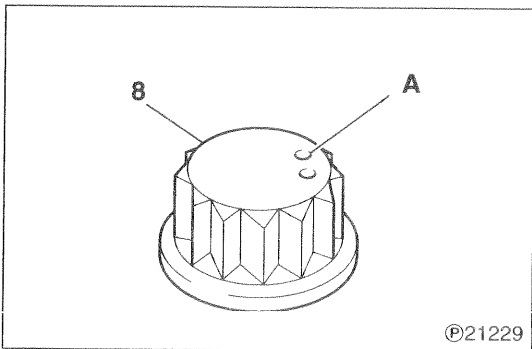

- Tighten the cylinder head bolts **8** to the specified torque (M14 bolts: 78 N·m {8 kgf·m}; M10 bolts: 17 N·m {1.75 kgf·m}) in the sequence shown. Then, turn the bolts further in accordance with the following procedure.

\*: Tighten together with rocker and bracket assembly

- ① to ②⑥ : M14 bolt (wet)
- ②⑦ to ③② : M10 bolt

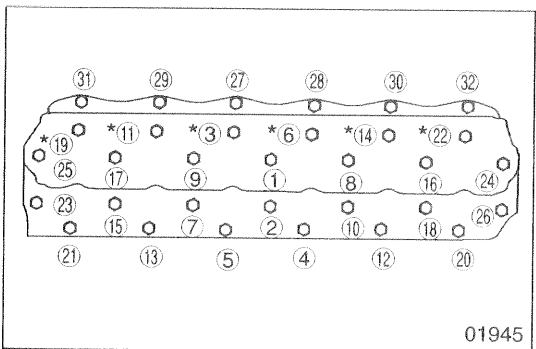

<M14 Bolts>

- Before fitting the  Socket Wrench over a cylinder head bolt, turn the holder **D** counter-clockwise to tension the built-in spring.

**E**: Socket  
**F**: Rod  
**G**: Rod (extension)

- Set the socket such that the built-in spring force forces the rod **G** against the rocker shaft bracket, an injection pipe, or another nearby part.
- On the holder **D**, select the inscribed line **H** that is easiest to see.
- Using the selected line as a reference, turn the socket **E** 180° clockwise. (One gradation on the scale **J** represents 5°.)

## CAUTION

Since the M14 cylinder head bolts **8** utilize the plastic region tightening method, they must not be tightened further after this procedure.

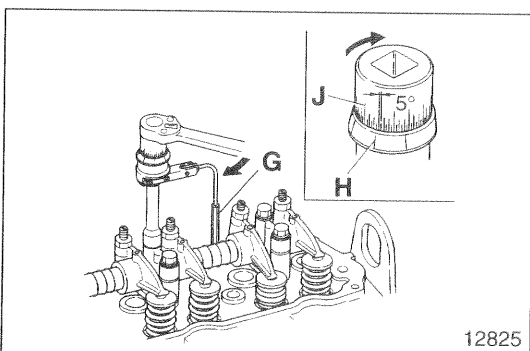
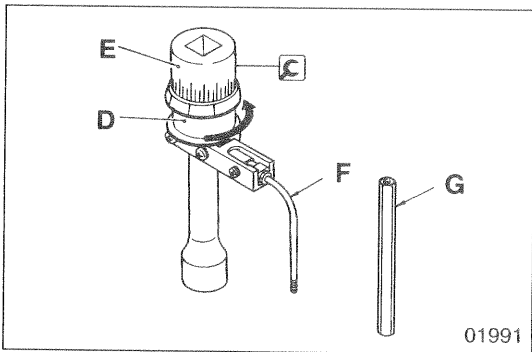

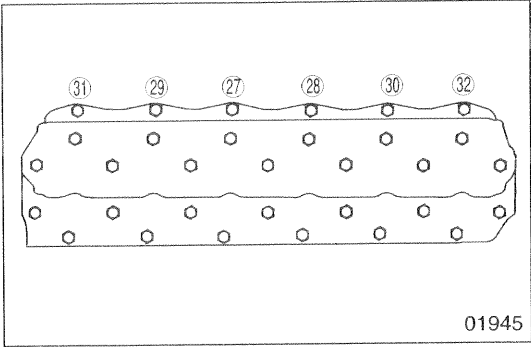

<M10 Bolts>

- After fitting the M14 cylinder head bolts 8, tighten the M10 bolts to the specified torque (34 N · m {3.5 kgf · m}) in the sequence shown.

11 Cylinder head gasket

[Removal]

CAUTION

When removing the cylinder head gasket 11, be careful not to scratch the cylinder head and valve assembly 10 and the crankcase \*.

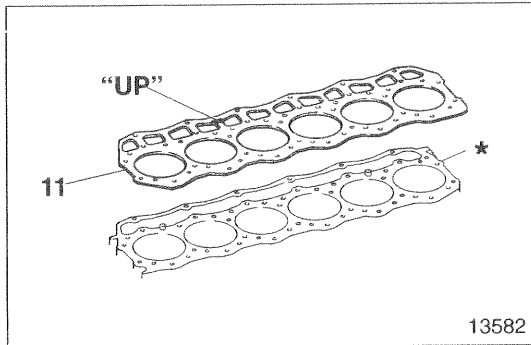

[Fitting]

- Fit the cylinder head gasket 11 onto the crankcase \* as shown.

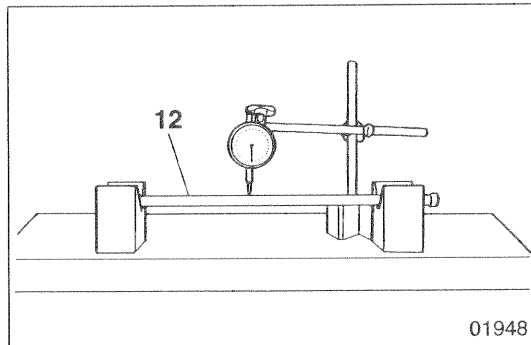

12 Push rod runout

If any measurement exceeds the specified limit, replace the defective part(s).

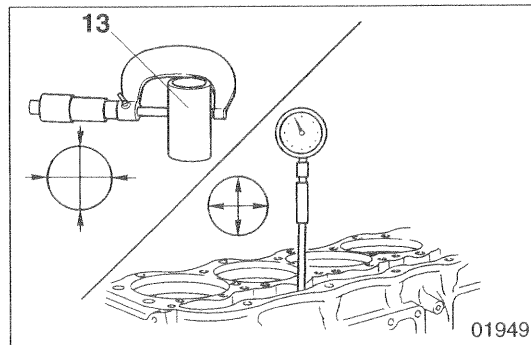

13 \* Tappet-to-crankcase clearance

If any measurement exceeds the specified limit, replace the defective part(s).

# CYLINDER HEAD AND VALVE MECHANISM

## Rocker and Bracket Assembly

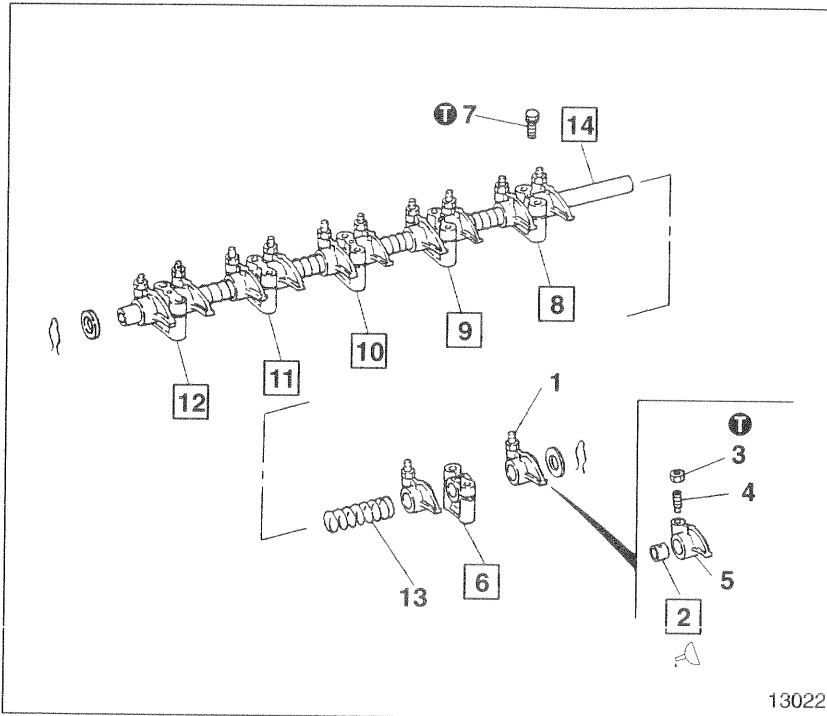

### ● Disassembly sequence

- 1 Rocker assembly
- 2 Rocker bushing
- 3 Lock nut
- 4 Adjusting screw
- 5 Rocker
- 6 No. 6 rocker shaft bracket
- 7 Set screw
- 8 No. 5 rocker shaft bracket
- 9 No. 4 rocker shaft bracket
- 10 No. 3 rocker shaft bracket
- 11 No. 2 rocker shaft bracket
- 12 No. 1 rocker shaft bracket
- 13 Rocker shaft spring
- 14 Rocker shaft

### ● Assembly sequence

Reverse the order of disassembly.

## Service standards

Unit: mm

Location	Maintenance item	Standard value (Basic diameter in [ ])	Limit	Remedy
2, 14	Rocker bushing-to-rocker shaft clearance	[24] 0.01 to 0.08	0.12	Replace

## ① Tightening torques

Unit: N·m {kgf·m}

Location	Parts to be tightened	Tightening torque	Remarks
3	Adjusting screw lock nut	34 {3.5}	—
7	Rocker shaft set screw	3.9 {0.4}	—

## 🔊 Lubricant

Location	Points of application	Specified lubricant	Quantity
2	Rocker bushing inner surface	Engine oil	As required

## 🛠️ Special tools

Unit: mm

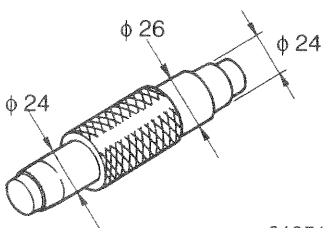
Location	Tool name and shape	Part No.	Application
2	Rocker Bushing Puller  01951	MH061777	Removing and installing rocker bushings

◆ Service procedure

2 14 Rocker bushing and rocker shaft

[Inspection]

If any clearance exceeds the specified limit, replace the defective part(s).

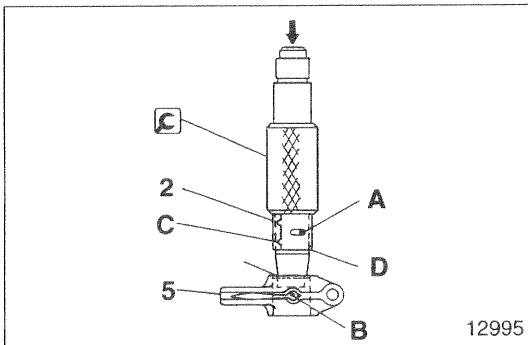
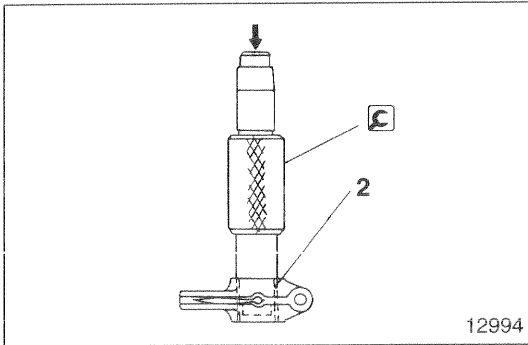
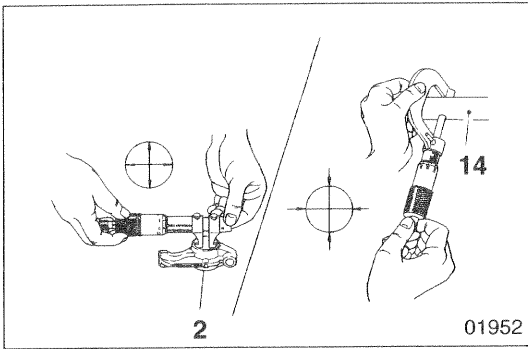

Rocker bushing

[Removal]

[Installation]

- Align the oil hole **A** in the rocker bushing **2** with the oil hole **B** in the rocker **5**.
- Position the notch **C** and seam **D** on the rocker bushing **2** as shown.
- Install the rocker bushing **2** into the rocker **5** from the chamfered side **F**.

6 8 to 12 14 Installing rocker shaft brackets and rocker shaft

Rocker shaft brackets

Be sure to fit the rocker shaft brackets **6**, **8**, **12** in their correct positions.

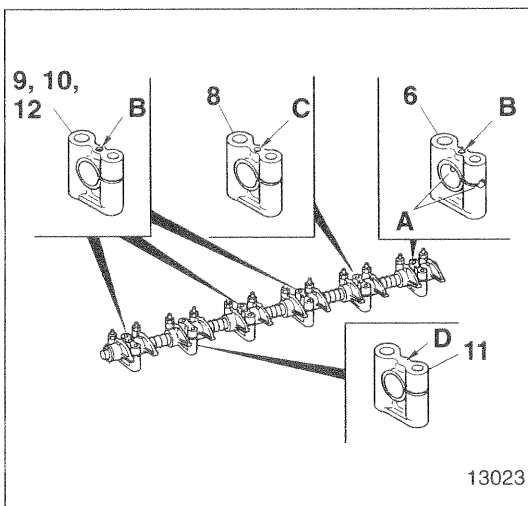

- A**: Oil hole
- B**: Threaded hole (for M8 rocker cover bolt)
- C**: Threaded hole (for M6 set screw)
- D**: No threaded hole

# CYLINDER HEAD AND VALVE MECHANISM

---

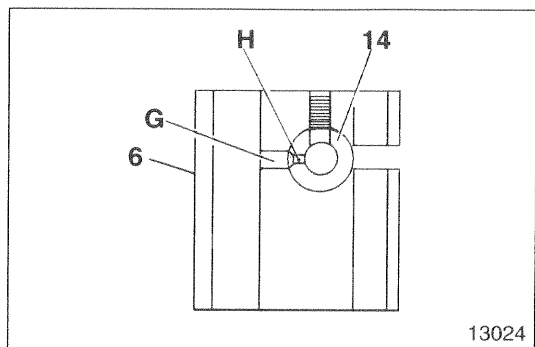

## Rocker shaft

Align the oil hole **G** in the No. 6 rocker shaft bracket **6** with the oil hole **H** in the rocker shaft **14**.

---

# MEMO

---

# CYLINDER HEAD AND VALVE MECHANISM

## Cylinder Head and Valve Mechanism

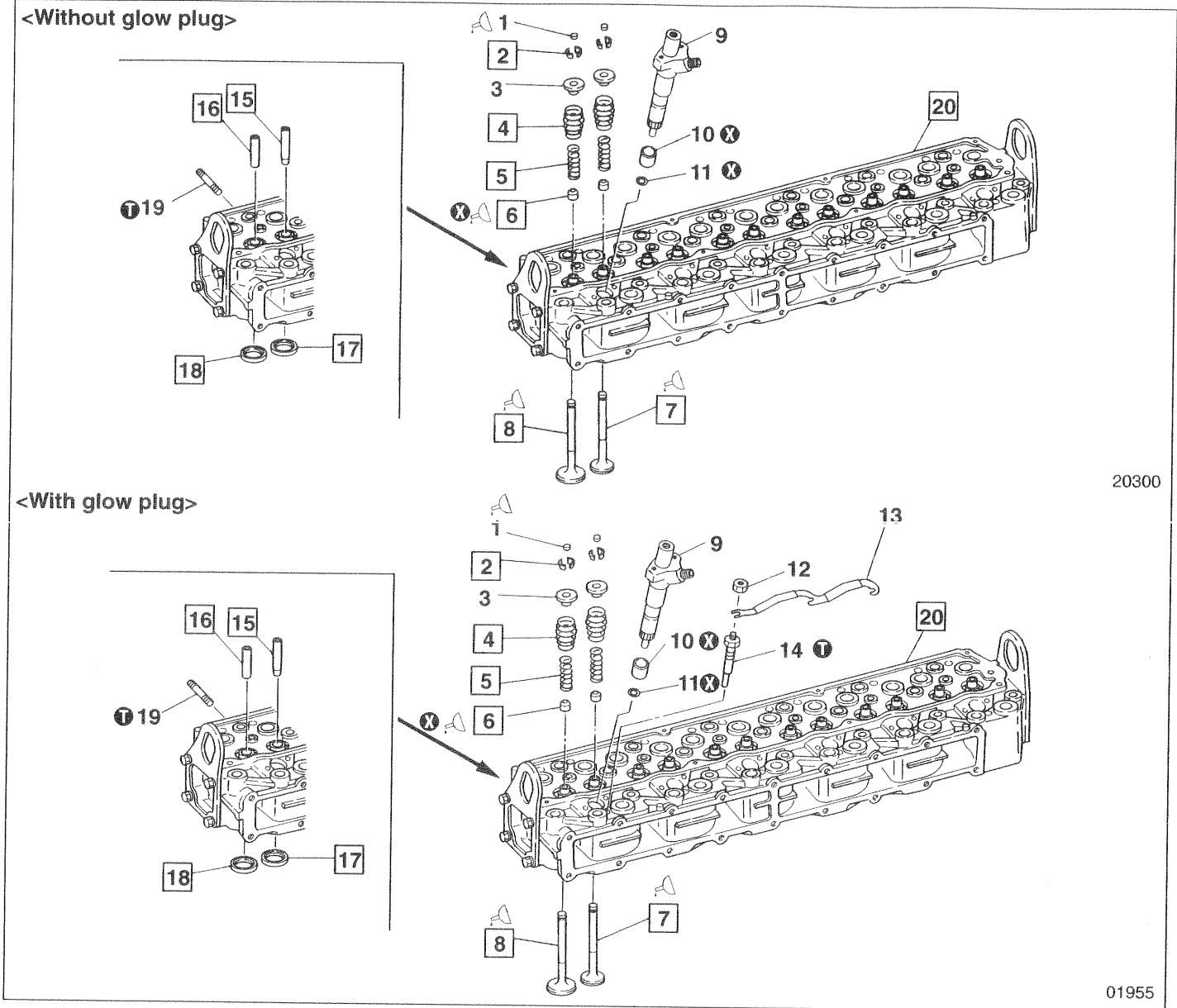

20300

01955

### ● Disassembly sequence

- |                      |                               |                       |
|----------------------|-------------------------------|-----------------------|
| 1 Valve cap          | 9 Injection nozzle  Gr 13     | 16 Inlet valve guide  |
| 2 Valve cotter       | 10 Dust seal                  | 17 Exhaust valve seat |
| 3 Upper retainer     | 11 Nozzle tip gasket          | 18 Inlet valve seat   |
| 4 Outer valve spring | 12 Nut <With glow plug>       | 19 Stud               |
| 5 Inner valve spring | 13 Connecting plate           | 20 Cylinder head      |
| 6 Valve stem seal    | <With glow plug>              |                       |
| 7 Exhaust valve      | 14 Glow plug <With glow plug> |                       |
| 8 Inlet valve        | Gr 54                         |                       |
|                      | 15 Exhaust valve guide        |                       |

⊗ : Non-reusable part

### CAUTION

The injection nozzles 9 and glow plugs 14 project from the bottom surface of cylinder head 20. Take care not to damage them.

### ● Assembly sequence

Follow the disassembly sequence in reverse.

### NOTE

Any valve stem seal 6 removed from an exhaust valve 7 or inlet valve 8 must be replaced.

## Service standards

Unit: mm

Location	Maintenance item		Standard value (Basic diameter in [ ])	Limit	Remedy	
4	Outer valve spring	Free length	6D14, 14-T, 15-T, 16, 16-E	67.0	64.0	Replace
			6D16-T, 16-TE, 16-TL, 16-TLE	68.3	65.3	
	Installed load (at 47.8 installed length)	6D14, 14-T, 15-T, 16, 16-E	6D14, 14-T, 15-T, 16, 16-E	330 N {33.5 kgf}	290 N {29.7 kgf}	Replace
			6D16-T, 16-TE, 16-TL, 16-TLE	390 N {40.0 kgf}	350 N {35.5 kgf}	
	Squareness		—	2.5	Replace	
5	Inner valve spring	Free length	6D14, 14-T, 15-T, 16, 16-E	55.1	52.1	Replace
			6D16-T, 16-TE, 16-TL, 16-TLE	65.1	61.5	
	Installed load (at 40.5 installed length)	6D14, 14-T, 15-T, 16, 16-E	6D14, 14-T, 15-T, 16, 16-E	92 N {9.4 kgf}	78 N {8.0 kgf}	Replace
			6D16-T, 16-TE, 16-TL, 16-TLE	155 N {15.8 kgf}	130 N {13.4 kgf}	
	Squareness	6D14, 14-T, 15-T, 16, 16-E	6D14, 14-T, 15-T, 16, 16-E	—	2.0	Replace
			6D16-T, 16-TE, 16-TL, 16-TLE	—	2.5	
7	Exhaust valve	Stem outside diameter		$\phi$ 8.93 to 8.94	$\phi$ 8.85	Replace
		Sinkage from cylinder head bottom surface		1.3 to 1.7	2.0	Inspect every location
		Valve margin		1.5	1.2	Reface or replace
		Seat angle		45°	—	Correct
8	Inlet valve	Stem outside diameter		$\phi$ 8.96 to 8.97	$\phi$ 8.85	Replace
		Sinkage from cylinder head bottom surface	Except 6D16-E	1.1 to 1.5	1.8	Inspect every location
			6D16-E	1.3 to 1.7	2.0	
		Valve margin		1.5	1.2	Reface or replace
		Seat angle		45° ± 15'	—	Correct
7, 15	Exhaust valve stem-to-valve guide clearance		[9] 0.07 to 0.10	0.2	Replace	
8, 16	Inlet valve stem-to-valve guide clearance		[9] 0.04 to 0.06	0.15	Replace	
17	Exhaust valve seat width		1.8 to 2.2	2.8	Correct or replace	
18	Inlet valve seat width		1.8 to 2.2	2.8	Correct or replace	
20	Cylinder head	Bottom surface distortion		0.08 or less	0.2	Correct or replace
		Height from top to bottom surface		94.9 to 95.1	94.5	Replace

## ① Tightening torques

Unit: N · m {kgf · m}

Location	Parts to be tightened	Tightening torque	Remarks
14	Glow plug <With glow plug>	15 to 20 {1.5 to 2.0}	—
19	Exhaust manifold mounting stud	29 {3}	—

# CYLINDER HEAD AND VALVE MECHANISM

## Lubricant

Location	Points of application	Specified lubricant	Quantity
1	Rocker contact surface on valve cap top	Engine oil	As required
6	Lip of valve stem seal	Engine oil	As required
7, 8	Valve stem	Engine oil	As required

## Special tools

Unit: mm

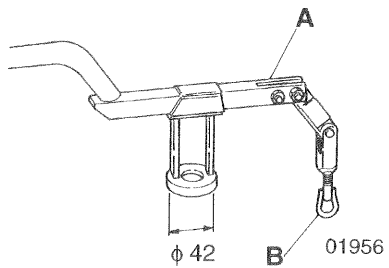
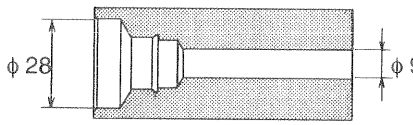
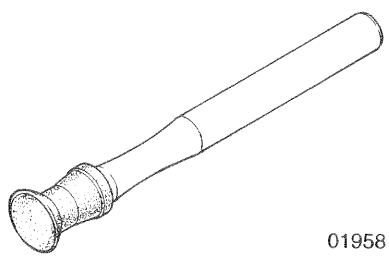
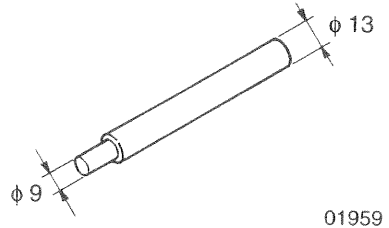
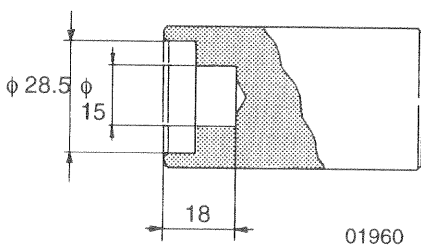
Location	Tool name and shape	Part No.	Application
2	<p>A: Valve Lifter B: Valve Lifter Hook</p>  <p>φ 42      01956</p>	<p>A: MH061668 (with φ 42 valve lifter seat) B: MH061679</p>	Removing and installing valve cotters
6	<p>Valve Stem Seal Installer</p>  <p>φ 28      φ 9</p> <p>01957</p>	MH061293	Installing valve stem seals
7, 8	<p>Valve Lapper</p>  <p>01958</p>	30091-07500 (inlet, exhaust)	Lapping valves and valve seats
15, 16	<p>Valve Guide Remover</p>  <p>φ 9      φ 13</p> <p>01959</p>	MH061066 (inlet, exhaust)	Removing valve guides
	<p>Valve Guide Installer</p>  <p>φ 28.5      φ 15</p> <p>18</p> <p>01960</p>	MH061998	Installing inlet and ex- haust valve guides

Location	Tool name and shape	Part No.	Application
17, 18	A: Caulking Tool Body B: Installer Ring	A: MH061067 B: MH061695	Installing valve seats
	MH061696 <6D14, 14-T, 15-T, 16-T, 16-TE, 16-TL, 16-TLE> (Inlet)		
	MH061693 <6D16, 16-E> (Inlet)		
		MH061696 <6D14, 14-T, 15-T, 16-T, 16-TE, 16-TL, 16-TLE> (Exhasut)	
		MH061693 <6D16, 16-E> (Inlet)	
		MH061694 <6D16, 16-E> (Exhaust)	

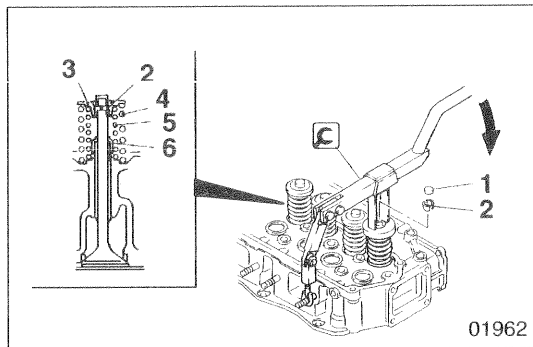

### ◆ Service procedures

#### 2 Valve cotters

[Removal]

To remove the valve cotter 2, use the Valve Lifter to evenly compress the valve springs 4, 5.

[Installation]

To install valve cotters, follow the removal instructions in reverse.

#### CAUTION

Do not compress the valve springs 4, 5 more than is necessary. If the valve springs are compressed excessively, the upper retainer 3 can touch the valve stem seal 6 and be damaged.

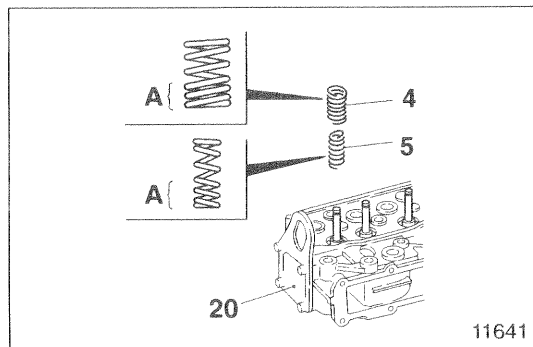

#### 4 5 Installing outer and inner valve springs

Fit the outer and inner valve springs 4, 5 onto the cylinder head 20 with their painted ends downward.

A: Painted end

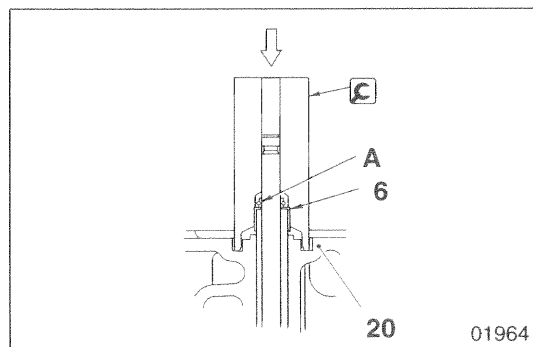

#### 6 Installing valve stem seals

- Apply engine oil to the lip A of the valve stem seal 6.
- Install the valve stem seal 6 using the Valve Stem Seal Installer. Strike the Valve Stem Installer until it sits snugly on the cylinder head 20.

# CYLINDER HEAD AND VALVE MECHANISM

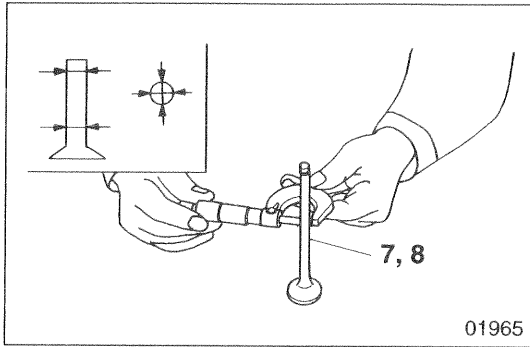

## 7 8 Valve

[Inspection]

### (1) Valve stem outside diameter

Replace the valve 7, 8 if its stem's outside diameter is below specification or severely worn.

#### CAUTION

Whenever a valve 7, 8 is replaced, be sure to lap the valve and valve seat 17, 18.  P.11-25.

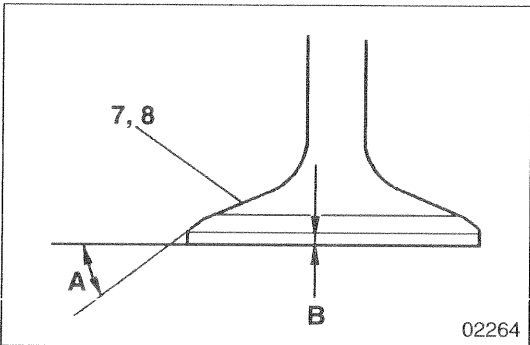

### (2) Valve seat angle and valve margin

Reface or replace the valve 7, 8 if the valve seat angle or valve margin exceeds the specified limits.

A: Valve seat angle

B: Valve margin

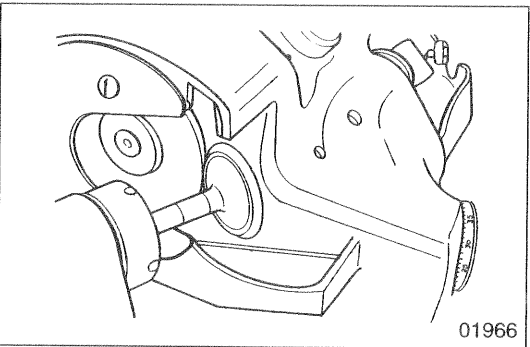

[Rectification]

#### NOTE

- Keep grinding to a minimum.
- If the valve margin is below specification after grinding, replace the valve 7, 8.
- After grinding, be sure to lap the valve and 7,8 valve seat 17, 18.  P.11-25

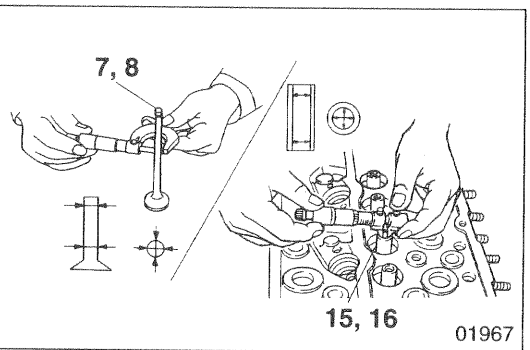

## 7 8 15 16 Valves and valve guides

[Inspection]

If any clearance exceeds the specified limit, replace the defective part(s).

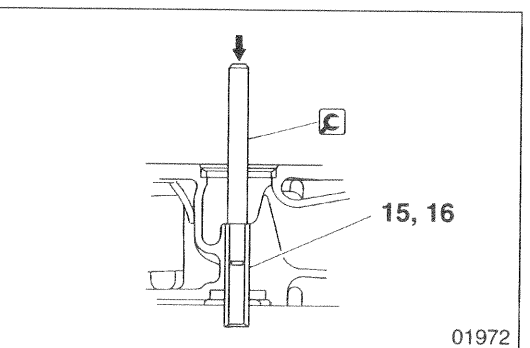

### Valve guides

[Removal]

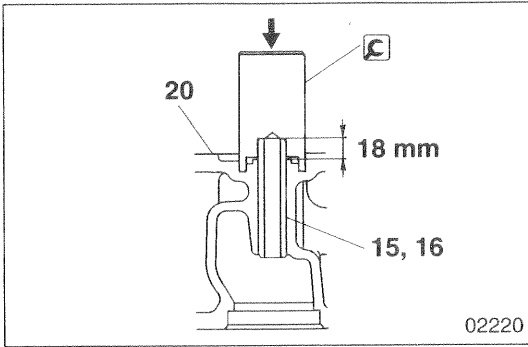

## [Installation]

Install the valve guide 15, 16 using the Valve Guide Installer. Strike the Valve Guide Installer until it sits snugly on the cylinder head 20.

**CAUTION**

- The valve guides 15, 16 must be pressed in to the specified depth. Be sure to use the Valve Guide Installer for this operation.
- Exhaust valve guides 15 are longer than inlet valve guides 16. Be sure to install the correct type of guide in each location.

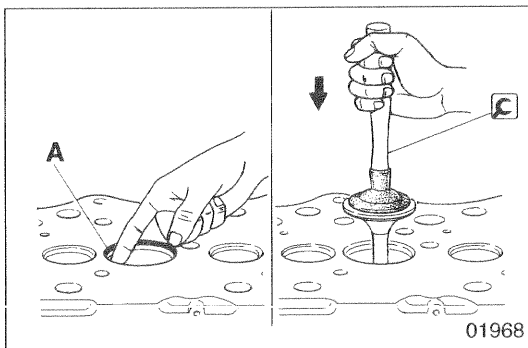
**7 8 17 18** Valves and valve seats

## [Inspection]

- Apply an even coat of minium to the valve seat 17, 18 surface A that makes contact with the valve 7, 8.
- Using the Valve Lapper, strike the valve 7, 8 against the valve seat 17, 18 once. Do not rotate the valve during this operation.

**NOTE**

Carry out these inspections after inspecting the valves and valve guides.

- If the minium deposited on the valve 7, 8 indicates a poor contact pattern, rectify the contact pattern as follows:

Contact	Corrective action
Minor defect	Lapping
Serious defect	Reface or replace valve and valve seat

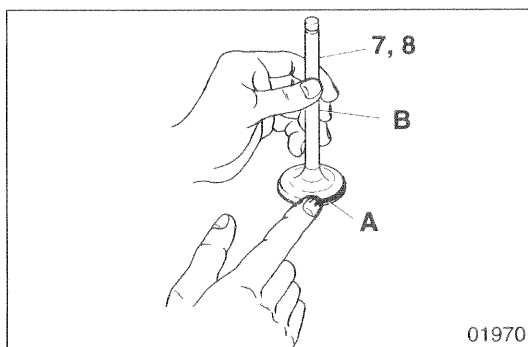
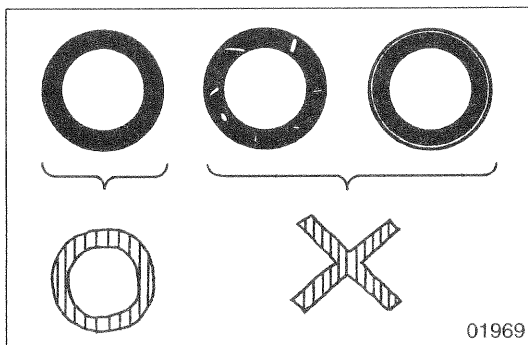

## [Refacing]

Lap the valve in accordance with the following procedure:

- Apply a thin, even coat of lapping compound to the surface A of the valve 7, 8 that makes contact with the valve seat 17, 18.

**CAUTION**

Ensure that no compound adheres to the stem B of the valve 7, 8.

**NOTE**

- Start with intermediate-mesh compound (120 to 150 mesh) and finish with fine-mesh compound (200 mesh or more).
- The addition of a small amount of engine oil makes lapping compound easier to apply.

# CYLINDER HEAD AND VALVE MECHANISM

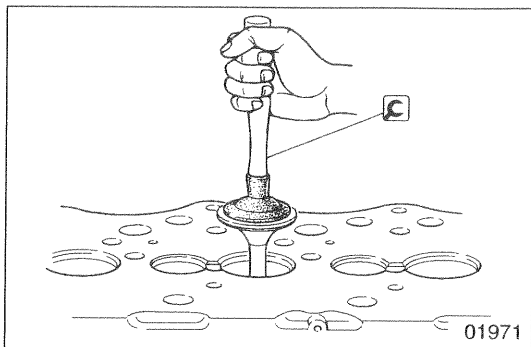

- Using the **C** Valve Lapper, lightly strike the valve **7, 8** against the valve seat **17, 18** while turning it little by little.
- Wash away the compound with gas oil or a similar fluid.
- Apply engine oil to the contact surfaces of the valve seat **17, 18** and rub it in so that the contact surfaces are lubricated and mate together snugly.
- Inspect the contact pattern of the valve **7, 8** and valve seat **17, 18** once more.
- If the contact pattern is still defective, replace the valve seat **17, 18**.

## **17 18** Valve seats

[Inspection]

### (1) Valve seat width

If the measurement exceeds the specified limit, rectify or replace the valve seat **17, 18**.

**A**: Valve seat width

### NOTE

Whenever a valve seat **17, 18** is rectified or replaced, be sure to lap the valve seat and valve **7, 8**. P.11-25

### (2) Valve sinkage from cylinder head bottom surface

If any measurement exceeds the specified limit, rectify or replace the defective part(s).

**B**: Valve sinkage

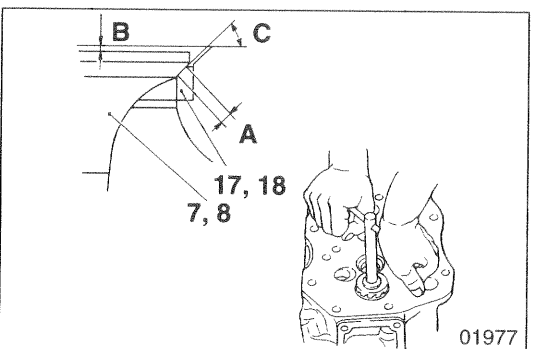
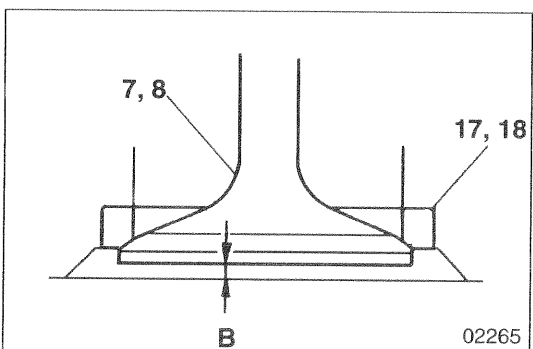
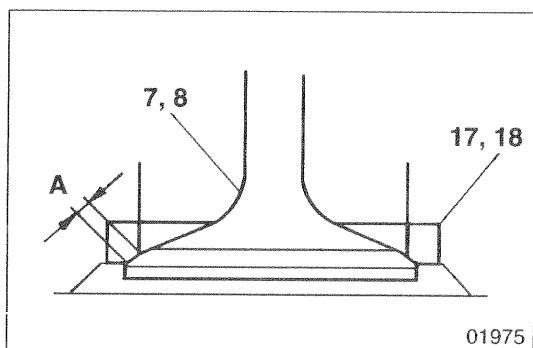

[Rectification]

- Grind the valve seat **17, 18** using a valve seat cutter or valve seat grinder.
- After grinding, put some sandpaper of around #400 grade between the cutter and valve seat and grind the valve seat lightly.
- Use a 15° or 17° cutter to achieve the specified valve seat width **A**.

**C**: Valve seat angle

### CAUTION

Ensure that grinding does not cause the valve sinkage **B** to exceed the specified limit.

- After rectification, lap the valve **7, 8** and valve seat **17, 18**.

P.11-25

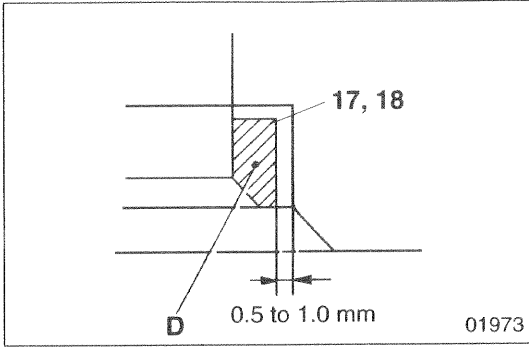

## [Removal]

Valve seats **17, 18** are installed by expansion fitting. To remove a valve seat, grind the inside surface to reduce its thickness, then remove the valve seat at room temperature.

**D**: Material to remove

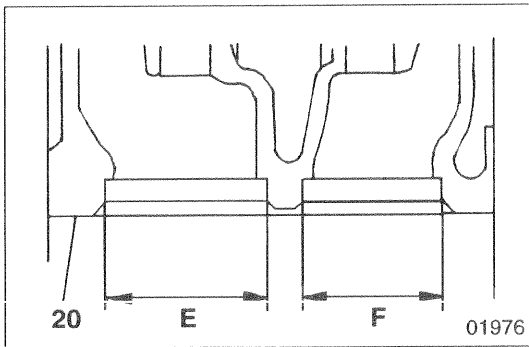

## [Installation]

- Check that the valve seat hole diameters **E, F** in the cylinder head **20** conform with the values shown below.

Unit: mm

	6D14, 14-T, 15-T, 16-T, 16-TE, 16-TL, 16-TLE	6D16	6D16-E
Inlet valve seat hole ( <b>E</b> )	$\phi 49^{+0.025}_0$	$\phi 51^{+0.03}_0$	$\phi 53^{+0.03}_0$
Exhaust valve seat hole ( <b>F</b> )	$\phi 42^{+0.025}_0$	$\phi 44^{+0.025}_0$	$\phi 46^{+0.025}_0$

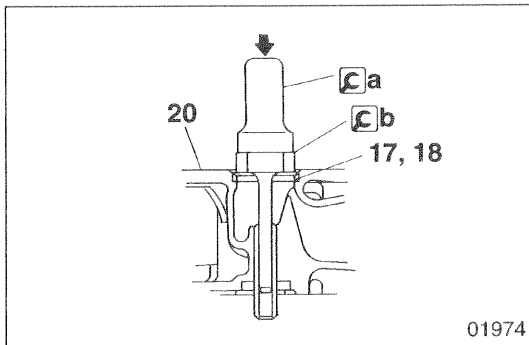

- Cool the valve seat **17, 18** by immersing it in liquid nitrogen.
- Install the valve seat **17, 18** in the cylinder head **20** using the **Ca** Caulking Tool Body and **Cb** Installer Ring.
- After installing the valve seat **17, 18**, lap the valve seat and valve **7, 8**.  
 P.11-25

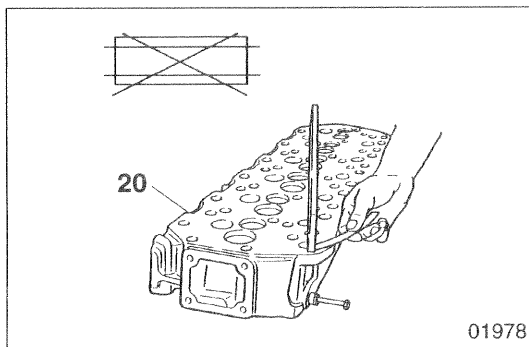
**20** Inspecting cylinder head

- Measure the extent of distortion in the cylinder head's bottom surface.
- If the degree of distortion exceeds the specified limit, rectify the distortion with a surface grinder.

**CAUTION**

Ensure that grinding does not cause the cylinder head's top surface-to-bottom surface distance to fall below the specified limit.

# PISTONS, CONNECTING RODS, AND CYLINDER LINERS

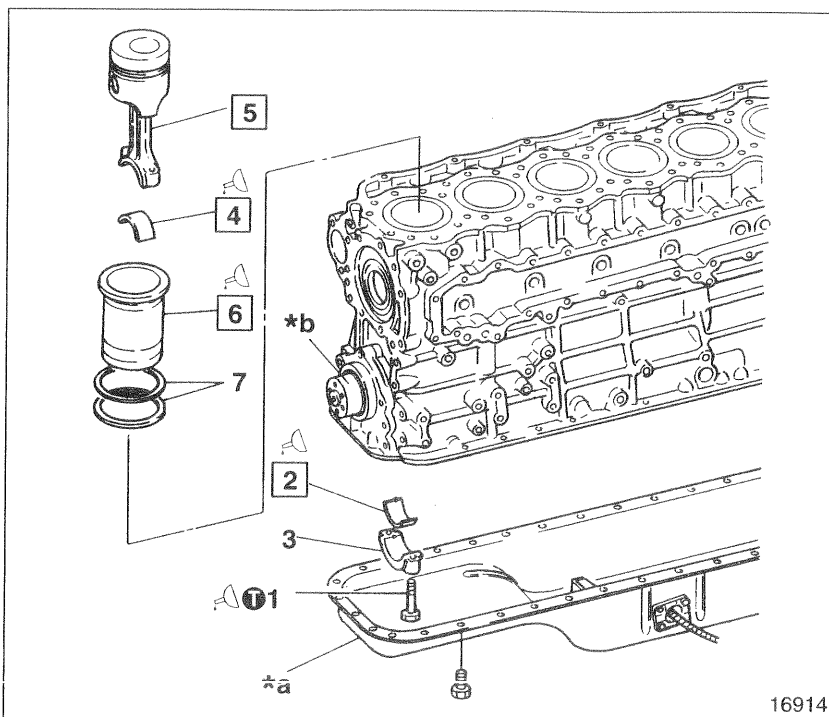

## ● Pre-disassembly inspection

📖 P.11-30

## ● Removal sequence

- 1 Bolt
- 2 Lower connecting rod bearing
- 3 Connecting rod cap
- 4 Upper connecting rod bearing
- 5 Piston and connecting rod assembly  
📖 P.11-36
- 6 Cylinder liner
- 7 O-ring <6D14, 14-T, 15-T>

\*a: Oil pan 📖 Gr 12

\*b: Crankshaft 📖 P.11-72

## ● Installation sequence

Reverse the order of removal.

## Service standards

Unit: mm

Location	Maintenance item		Standard value (Basic diameter in [ ])	Limit	Remedy	
—	Piston projection		0.85 to 1.06	—	Inspect each location	
	Connecting rod end play		0.15 to 0.45	0.6	Replace	
2, 4, *b	Connecting rod bearing	Oil clearance	Except 6D16-TLE	[65] 0.04 to 0.09	0.2	Replace
			6D16-TLE	[70] 0.04 to 0.09		
	Span when free	Except 6D16-TLE	—	Less than 69.5		
		6D16-TLE	—	Less than 74.5		
5, 6	Piston and connecting rod assembly-to-cylinder liner clearance	6D14, 14-T		[110] 0.137 to 0.159	—	Replace
		6D15-T		[113] 0.166 to 0.138	—	Replace
		6D16, 16-E		[118] 0.075 to 0.105	—	Replace
		6D16-T, 16-TE, 16-TL, 16-TLE		[118] 0.136 to 0.165	—	Replace
6	Cylinder liner	Flange projection		0.03 to 0.10	—	Replace
		Inside diameter	6D14, 14-T		φ 110 to 110.035	φ 110.25
	6D15-T		φ 113 to 113.035	φ 113.25	Replace	
	6D16, 16-E, 16-T, 16-TE, 16-TL, 16-TLE		φ 118 to 118.03	φ 118.25	Replace	
	Cylindricity	6D14, 14-T, 15-T		0.02 or less	—	Replace or grind to oversize
		6D16, 16-E, 16-T, 16-TE, 16-TL, 16-TLE		0.03 or less	—	Replace or grind to oversize

## ⓘ Tightening torques

Unit: N · m {kgf · m}

Location	Parts to be tightened	Tightening torque	Remarks
1	Bolt (connecting rod installation)	29 {3} + 90° ± 5°	Wet P.11-31

## 👉 Lubricant

Location	Points of application	Specified lubricant	Quantity
1	Bolt threads	Engine oil	As required
2, 4	Connecting rod bearing inside surface	Engine oil	As required
6	Cylinder liner outside surface	Engine oil	As required

## 🛠️ Special tools

Unit: mm

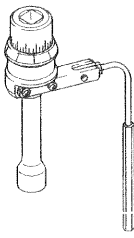
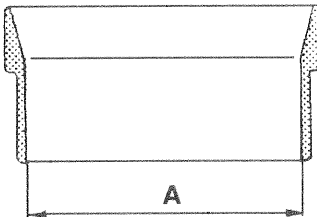
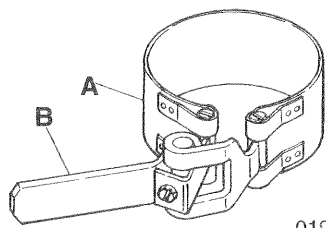
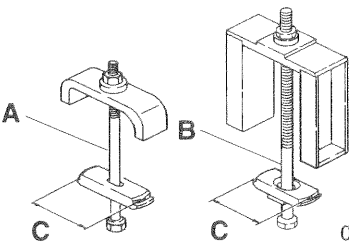
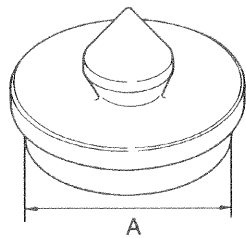
Location	Tool name and shape	Part No.	Application								
5	Socket Wrench 	MH061560	Installing piston and connecting rod assembly								
5	Piston Guide <table border="1"> <thead> <tr> <th></th> <th>A dimension</th> </tr> </thead> <tbody> <tr> <td>6D14, 14-T</td> <td>φ 110</td> </tr> <tr> <td>6D15-T</td> <td>φ 113</td> </tr> </tbody> </table> 		A dimension	6D14, 14-T	φ 110	6D15-T	φ 113	<6D14, 14-T> 30091-08200 <6D15-T> MH061327	Installing piston and connecting rod assembly		
		A dimension									
6D14, 14-T	φ 110										
6D15-T	φ 113										
A: Piston Guide Clamp B: Piston Guide Lever 	<6D16, 16-E, 16-T, 16-TE, 16-TL, 16-TLE> A: MH061760 B: MH061658										
6	Cylinder Liner Extractor <table border="1"> <thead> <tr> <th></th> <th>C dimension</th> </tr> </thead> <tbody> <tr> <td>6D14, 14-T</td> <td>φ 109.5</td> </tr> <tr> <td>6D15-T</td> <td>φ 112.5</td> </tr> <tr> <td>6D16, 16-E, 16-T, 16-TE, 16-TL, 16-TLE</td> <td>φ 117.5</td> </tr> </tbody> </table> 		C dimension	6D14, 14-T	φ 109.5	6D15-T	φ 112.5	6D16, 16-E, 16-T, 16-TE, 16-TL, 16-TLE	φ 117.5	<6D14, 14-T> A: MH061719 <6D15-T> B: MH062003 <6D16, 16-E, 16-T, 16-TE, 16-TL, 16-TLE> B: MH061761	Removing cylinder liners
		C dimension									
6D14, 14-T	φ 109.5										
6D15-T	φ 112.5										
6D16, 16-E, 16-T, 16-TE, 16-TL, 16-TLE	φ 117.5										
Cylinder Liner Installer <table border="1"> <thead> <tr> <th></th> <th>A dimension</th> </tr> </thead> <tbody> <tr> <td>6D15-T</td> <td>φ 112.5</td> </tr> <tr> <td>6D16, 16-E, 16-T, 16-TE, 16-TL, 16-TLE</td> <td>φ 117.5</td> </tr> </tbody> </table> 		A dimension	6D15-T	φ 112.5	6D16, 16-E, 16-T, 16-TE, 16-TL, 16-TLE	φ 117.5	<6D15-T> MH062002 <6D16, 16-E, 16-T, 16-TE, 16-TL, 16-TLE> MH061771	Installing cylinder liners (dry type)			
	A dimension										
6D15-T	φ 112.5										
6D16, 16-E, 16-T, 16-TE, 16-TL, 16-TLE	φ 117.5										

# PISTONS, CONNECTING RODS, AND CYLINDER LINERS

## ◆ Service procedure

### ● Pre-disassembly inspection

#### (1) Piston projection from crankcase top surface

##### NOTE

The piston projections affect engine performance and must therefore be checked.

##### WARNING

With 6D16, 16-E, 16-T, 16-TE, 16-TL and 16-TLE engines, the cylinder liners may rise out of position when the crankcase is turned over or the crankshaft is turned. Hold their flanges down using bolts and washers A.

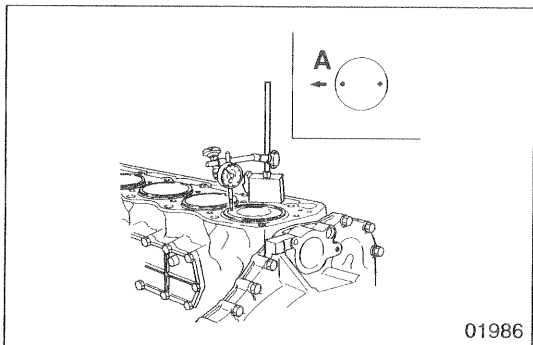
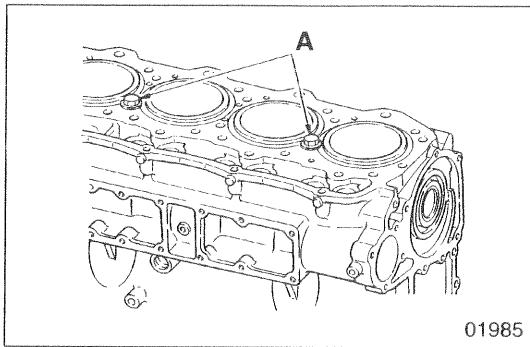

- Measure the projection of each piston at two points and calculate the average of the two values.

A: Front of engine

- If the average value is out of specification, check the clearances between all relevant parts.

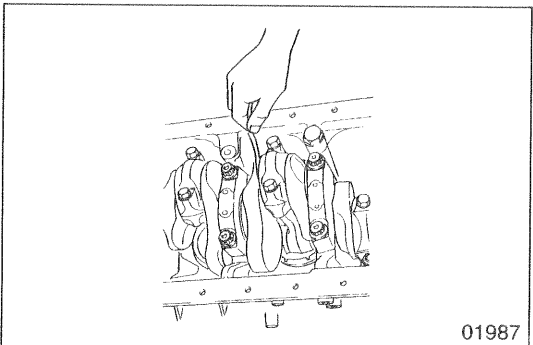

#### (2) Connecting rod end play

- Measure the end play of every connecting rod.
- If any measurement exceeds the specified limit, replace the defective part(s).

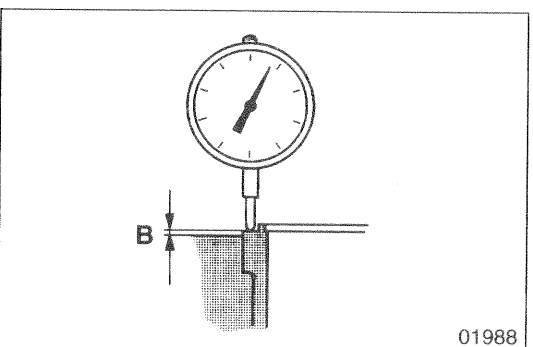

#### (3) Cylinder liner flange projection

If any measurement is out of specification, replace the defective part(s).

B: Flange projection

##### CAUTION

If the cylinder liner 6 flange projection is insufficient, bearing pressure on the cylinder head gasket will be too low in the region of the bore, possibly causing gas to leak.

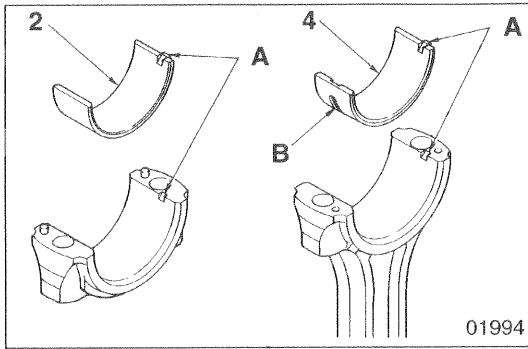

## 2 4 Connecting rod bearings

[Installation]

Install the connecting rod bearings 2, 4 by fitting the lugs **A** into their respective grooves.

**CAUTION** ⚠

The upper connecting rod bearing has an oil hole **B**. The lower connecting rod bearing has no oil hole. Take care not to confuse the upper and lower parts.

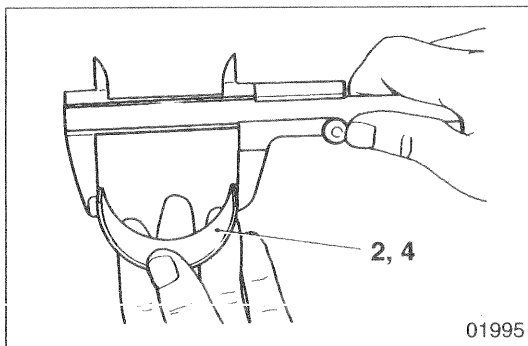

[Inspection]

**CAUTION** ⚠

- Do not attempt to manually expand a connecting rod bearing 2, 4 if its span is insufficient.
- Upper and lower connecting rod bearings 2, 4 must be replaced as a set.

### (1) Span when free

If the span is less than the specified requirement, replace the upper and lower connecting rod bearings 2, 4 as a set.

### (2) Connecting rod bearing-to-crankshaft pin clearance

If the connecting rod bearing-to-crankshaft pin clearance exceeds the specified limit, replace the defective part(s).

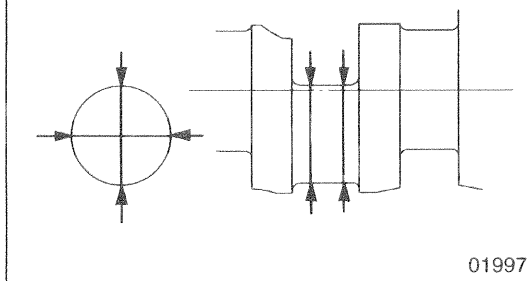
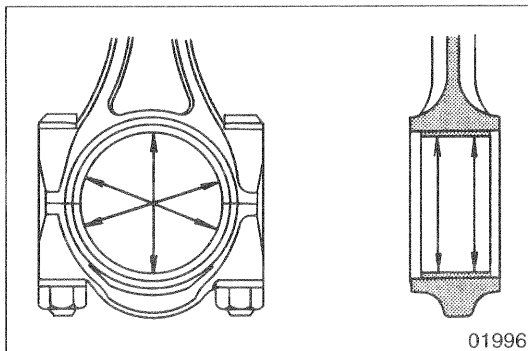

## 5 Installing piston and connecting rod assembly

**CAUTION** ⚠

- Ensure that the piston ring gaps **A** remain in their correct positions. P.11-41
- Take care not to damage the piston crown **B** (the area that forms part of the combustion chamber).
- Ensure that the connecting rod does not touch the oil jet **C**.

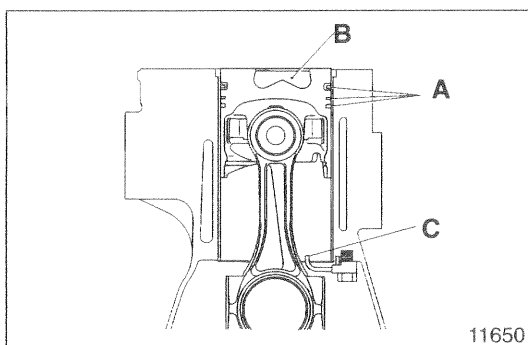

# PISTONS, CONNECTING RODS, AND CYLINDER LINERS

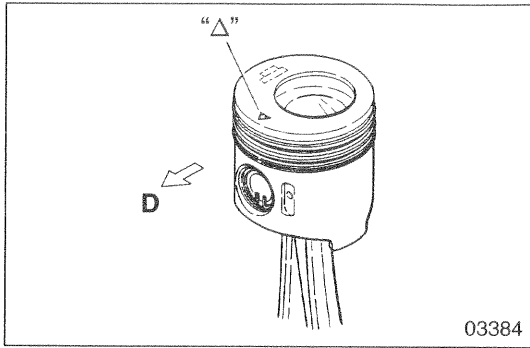

- With the piston's "Δ" front mark facing the front of the engine, install the piston and connecting rod assembly in accordance with the following procedure.

D: Front of engine

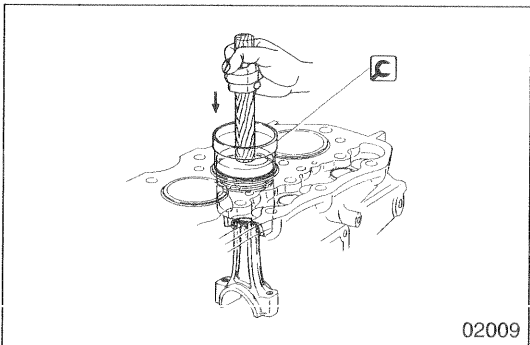

<6D14, 14-T, 15-T>

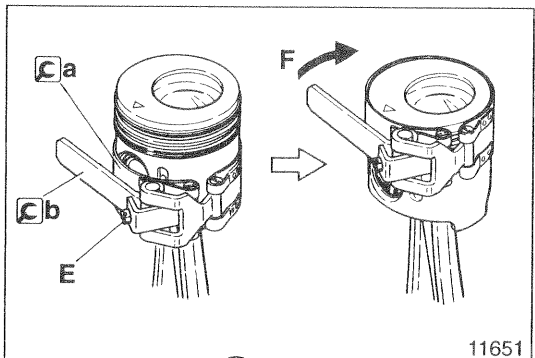

<6D16, 16-E, 16-T, 16-TE, 16-TL, 16-TLE>

- Fit the **Ca** Piston Guide Clamp over the piston skirt. Using the bolt **E** of the **Cb** Piston Guide Lever, adjust the clamp's inside diameter such that it matches the piston's outside diameter.
- Once the **Ca** Piston Guide Clamp is adjusted properly, remove it from the piston and smear engine oil over the following items:
  - Outside of piston
  - Inside of the **Ca** Piston Guide Clamp
  - Cylinder liner

F: **Ca** Piston Guide Clamp tightening direction

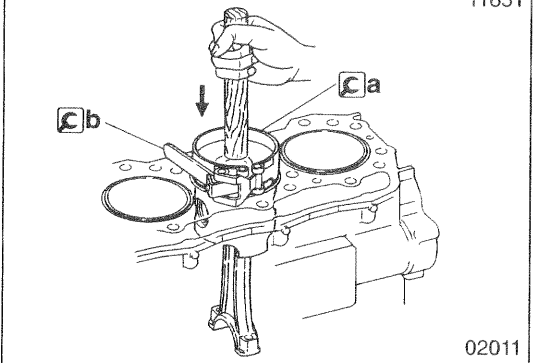

- With the piston installed, align the mating marks **F** on the connecting rod and connecting rod cap **3** and tighten the bolts to the specified torque. Then, tighten the bolts **1** further in accordance with the following procedure.

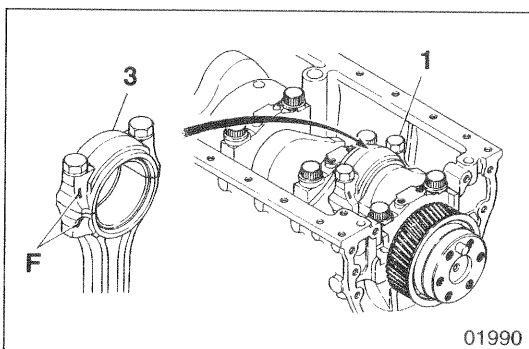

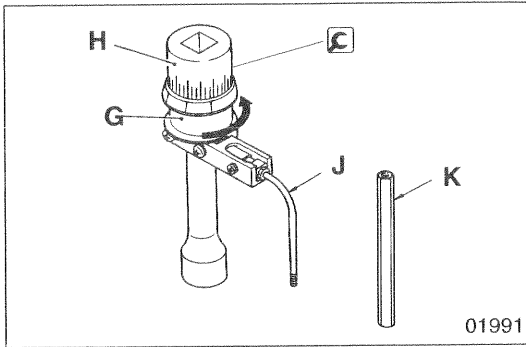

- Before fitting the  Socket Wrench over a bolt, turn the holder **G** counter-clockwise to tension the built-in spring.

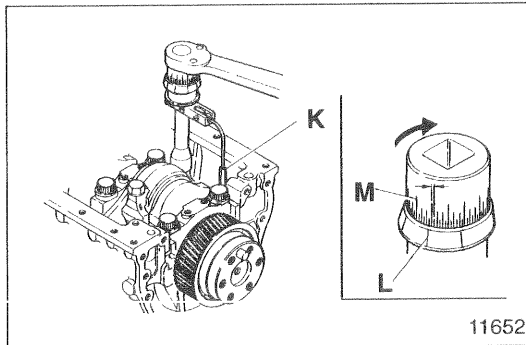

H: Socket  
J: Rod  
K: Rod (extension)



- Set the socket wrench such that the built-in spring force forces the rod **K** against the crankshaft.
- On the holder **G**, select the inscribed line **L** that is easiest to see.
- Using the selected line as a reference, turn the socket **H**  $90^\circ \pm 5^\circ$  clockwise. (One gradation on the scale **M** represents  $5^\circ$ .)

#### NOTE

After fitting the connecting rod caps **3**, inspect the following items:

- Connecting rod end play (  P.11-30)
- Piston projections (  P.11-30)

### 5 6 Piston-and-connecting rod assembly and cylinder liners

[Inspection]

<6D14, 14-T, 15-T>

- If the cylinder section inside diameter of the cylinder liner **6** exceeds the specified limit, remove the cylinder liner from the crankcase and rebores it to oversize. Also replace the piston and piston rings with ones suitable for the oversized cylinder liner inside diameter.

#### CAUTION

Even if only one cylinder requires boring, bore every cylinder to the same oversized inside diameter.

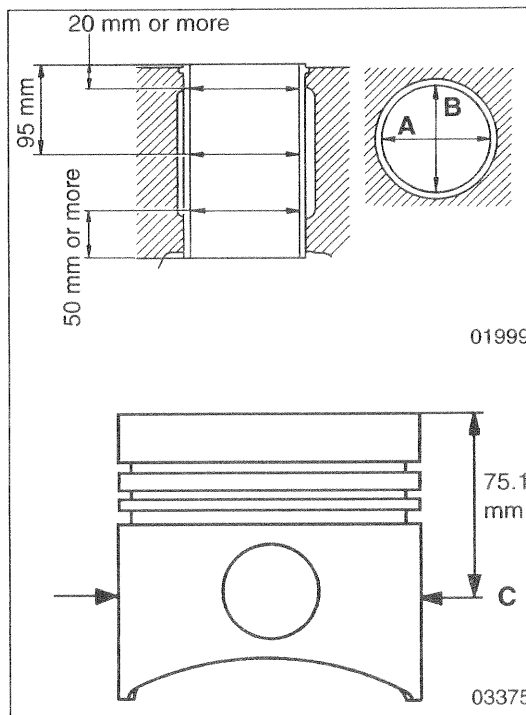

**A:** Measuring direction of cylinder liner bore (crankshaft axis direction)  
**B:** Measuring direction of cylinder liner bore (perpendicular to crankshaft axis)

**C:** Measuring position of piston diameter (perpendicular to piston pin hole axis)

- Even if the cylinder section inside diameter of the cylinder liner **6** is within the specified limit, the piston and piston rings must be replaced if the piston-to-cylinder liner clearance is out of specification.

[Use of oversize pistons]

- Oversizes available: 0.50 mm, 0.75 mm, 1.00 mm (three sizes in total)
- To determine the required oversize, measure the inside diameter of every cylinder and find the cylinder of the largest inside diameter. Select an oversize most suitable for the diameter.
- Measure the outside diameter **C** of the oversize piston to be used.
- Bore all the cylinder liners to achieve the specified nominal piston-to-cylinder clearance.

Diameter after boring (tolerance  $\pm 0.005$  mm) = Oversize piston diameter **C** (measurement) + Piston-to-cylinder clearance (nominal range central value) - 0.02 mm (honing margin)

# PISTONS, CONNECTING RODS, AND CYLINDER LINERS

- After boring, hone-finish the cylinder liner to the final diameter (tolerance  $\pm 0.005$  mm).  
Final diameter (tolerance  $\pm 0.005$  mm) = Oversize piston diameter C (measurement) + Piston-to-cylinder clearance (nominal range central value)

## CAUTION

- Honed surface roughness: 2 to 4  $\mu\text{m}$
- Honing cross-hatching angle: 15 to 25° (half angle)
- Squareness of cylinder bore: 0.05 mm

- Check the piston-to-cylinder clearance.

## Cylinder liners

[Removal]

### NOTE

If any cylinder liner 6 must be reused after removal, make an alignment mark with paint and use this mark to reinstall the cylinder liner in its original position.

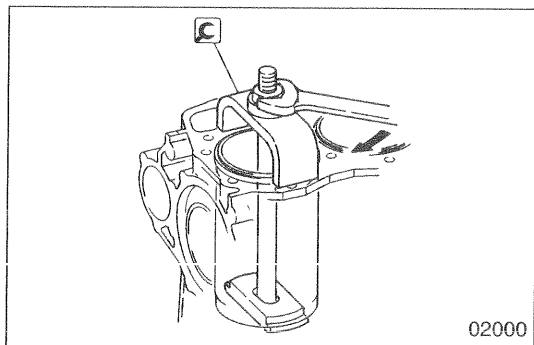

02000

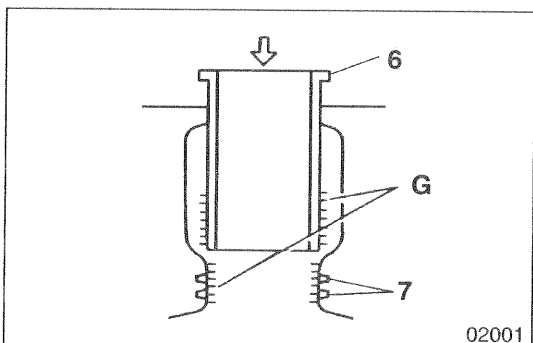

02001

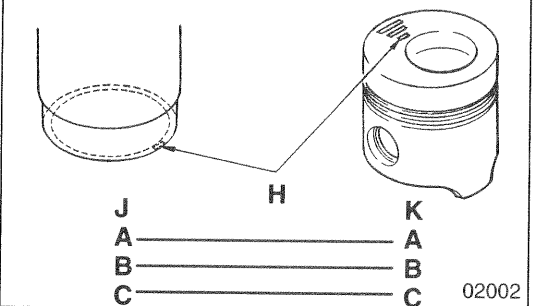

02002

[Installation]

Apply soap suds G to the cylinder liner 6. Taking care not to twist the O-rings 7, insert the cylinder liner into the crankcase.

## CAUTION

- Size marks H are provided on the cylinder liner 6 and piston. When the cylinder liner is replaced, the new one must bear the same size mark as the piston.

J: Cylinder liner size mark

K: Piston size mark

- After installation, check that the O-rings 7 are not twisted.

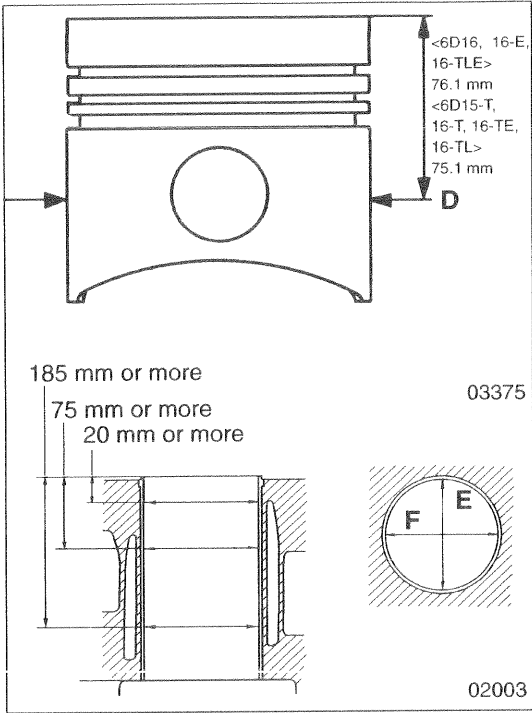

<6D15-T, 16, 16-E, 16-T, 16-TE, 16-TL, 16-TLE>

If any clearance is out of specification, replace the defective part(s).

D: Outside diameter measurement position

E: Direction of crankshaft axis

F: Perpendicular to crankshaft axis

**NOTE**

The cylinder liners are of a thin design and cannot be bored to oversize dimensions. To prevent deformation of the cylinder liners, do not remove them except for replacement.

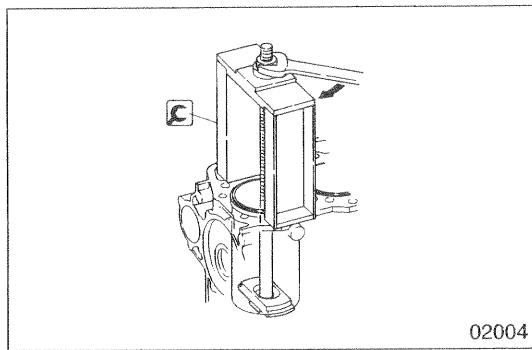

**Cylinder liners**

[Removal]

**NOTE**

If any cylinder liner 6 must be reused after removal, make an alignment mark with paint and use this mark to reinstall the cylinder liner in its original position.

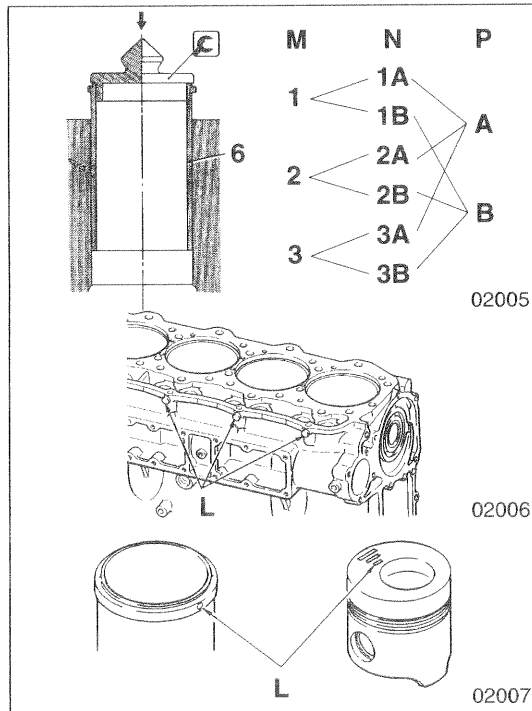

- Apply engine oil to the outside surface of the cylinder liner 6.
- Insert the cylinder liner into the crankcase and press it into position using the Cylinder Liner Installer. Push down evenly on the entire upper surface of the Cylinder Liner Installer.

**CAUTION**

- Size marks L are provided on the cylinder liner 6, piston, and crankcase (6 places). When the cylinder liner is replaced, select the proper one according to the size marks on the crankcase and the piston, as shown in the illustration.

M: Crankcase size mark

N: Cylinder liner size mark

P: Piston size mark

- The cylinder liners are of a thin design. Handle them with care, and do not subject them to hammer blows or other severe shocks.

# PISTONS, CONNECTING RODS, AND CYLINDER LINERS

## Piston and Connecting Rod Assembly

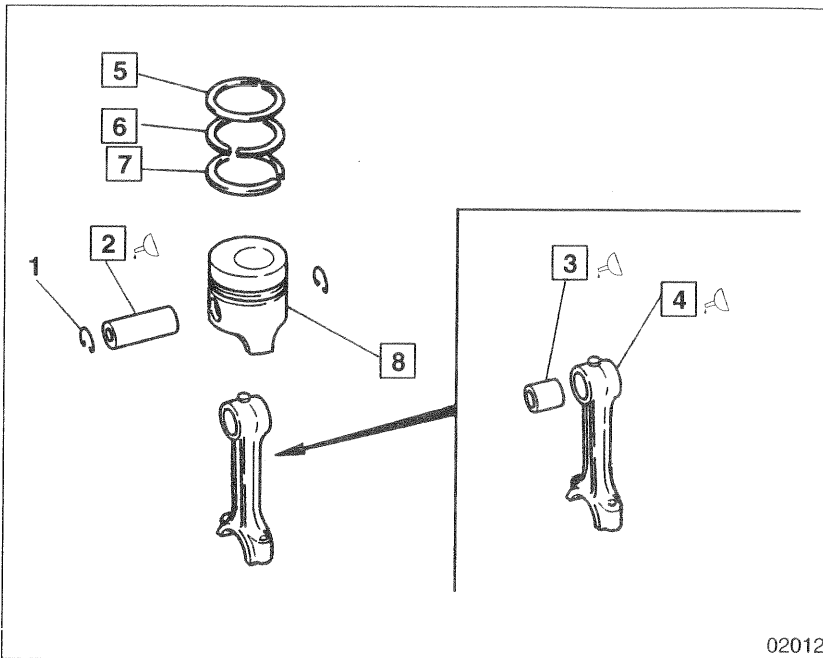

### ● Disassembly sequence

- 1 Snap ring
- 2 Piston pin
- 3 Connecting rod bushing
- 4 Connecting rod
- 5 1st compression ring
- 6 2nd compression ring
- 7 Oil ring
- 8 Piston

### ● Assembly sequence

Reverse the order of disassembly.

## Service standards

Unit: mm

Location	Maintenance item		Standard value (Basic diameter in [ ])	Limit	Remedy	
2, 3	Piston pin-to-connecting rod small end bushing clearance	Except 6D16-TLE	[38] 0.02 to 0.05	0.1	Replace	
		6D16-TLE	[42] 0.02 to 0.05			
2, 8	Piston pin-to-piston clearance	Except 6D16-TLE	[38] 0.004 to 0.02	0.05	Replace	
		6D16-TLE	[42] 0.004 to 0.02			
4	Connecting rod bend and torsion		—	0.05	Correct or replace	
5 to 7	Piston ring end gap	1st compression ring	6D14, 14-T, 15-T (B type)	0.3 to 0.45	1.5	Replace
			6D15-T (A type)	0.3 to 0.5		
			6D16, 16-T, 16-TL	0.35 to 0.55		
			6D16-E, 16-TE, 16-TLE	0.35 to 0.5		
		2nd compression ring	6D14	0.3 to 0.5	1.5	Replace
			6D14-T, 15-T	0.3 to 0.45		
			6D16, 16-T, 16-TL	0.35 to 0.55		
			6D16-E, 16-TE	0.35 to 0.5		
			6D16-TLE	0.45 to 0.6		
		Oil ring	6D14, 14-T, 15-T	0.3 to 0.5	1.5	Replace
6D16, 16-E, 16-T, 16-TE, 16-TL, 16-TLE	0.35 to 0.55					

Location	Maintenance item		Standard value (Basic diameter in [ ])	Limit	Remedy	
5 to 8	Piston ring-to-piston ring groove clearance	1st compression ring	6D14	0.09 to 0.13	0.2	Replace
			6D14-T, 15-T (B type)	0.05 to 0.10	0.15	Replace
			6D15-T (A type)	0.10 to 0.15	0.2	
			6D16	0.11 to 0.15	0.2	
			6D16-E	0.13 to 0.17	0.2	
			6D16-T, 16-TL, 16-TLE	0.13 to 0.18	0.2	
	2nd compression ring	6D14, 15-T (A type), 16, 16-E	0.05 to 0.08	0.15	Replace	
		6D14-T, 15-T (B type), 16-T, 16-TE, 16-TL, 16-TLE	0.07 to 0.10	0.15		
Oil ring			0.03 to 0.06	0.15	Replace	

\*6D15-T (B type): wedge-shaped connecting rod small end

### Lubricant

Location	Points of application	Specified lubricant	Quantity
2	Piston pin outer surface	Engine oil	As required
3	Connecting rod bushing outer surface	Engine oil	As required
4	Bushing installation surface of connecting rod	Engine oil	As required

### Special tools

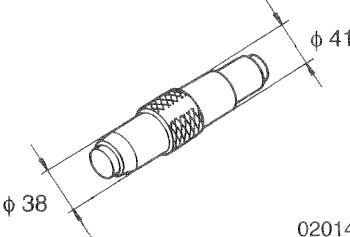
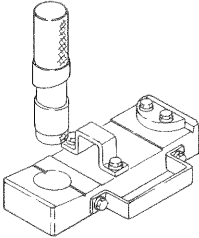
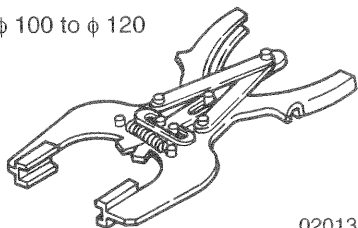
Location	Tool name and shape	Part No.	Application
3	Connecting Rod Bushing Puller  02014	<6D14, 15-T (A type), 16, 16-E> MH061778	Removing and installing connecting rod bushings
	Connecting Rod Bushing Puller Kit  02015	<6D14-T, 15-T (B type), 16-T, 16-TE, 16-TL> MH062023  <6D16-TLE> MH062556	
5 to 7	Piston Ring Tool  02013	30091-07100	Removing and installing piston rings

# PISTONS, CONNECTING RODS, AND CYLINDER LINERS

## ◆ Service procedure

### 2 3 Piston and connecting rod

If the clearance exceeds the specified limit, replace the defective part(s).

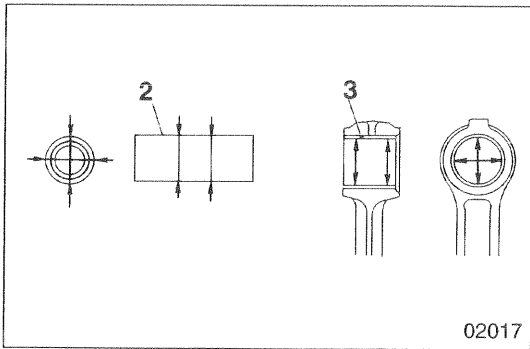

## Connecting rod bushing

<6D14, 15-T (A-type), 16, 16-E>

[Removal]

Apply the  Connecting Rod Bushing Puller to the connecting rod bushing 3. Using a press, apply pressure of approximately 49 kN (5,000 kgf) such that the bushing is pressed out of the connecting rod 4.

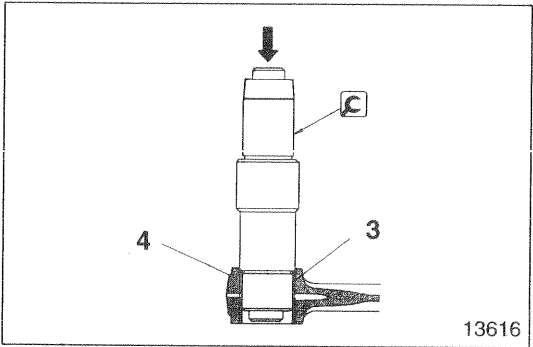

[Installation]

- Align oil hole A in the connecting rod bushing 3 with oil hole B in the connecting rod 4.
- Apply the  Connecting Rod Bushing Puller to the connecting rod bushing 3. Using a press, apply pressure of approximately 49 kN (5,000 kgf) such that the bushing is pressed into the connecting rod 4 from the chamfered side C.

## NOTE

After installing the connecting rod bushing 3, insert the piston pin 2 and check that it turns smoothly and without play.

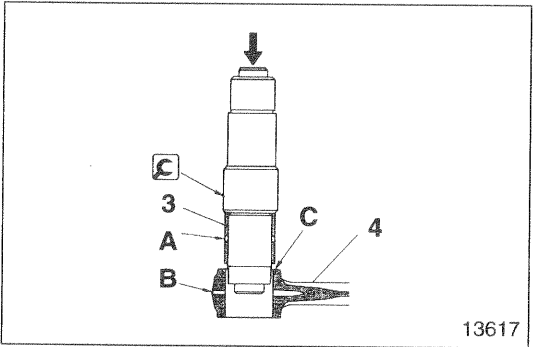

<6D14-T, 15-T (B-type), 16-T, 16-TE, 16-TL, 16-TLE>

Replace the connecting rod bushing **3** using the  Connecting Rod Bushing Puller Kit. This consists of the following parts:

- D: Base
- E: Bracket
- F: Puller
- G: Collar
- H: Plate
- J: Collar
- K: Nut

[Removal]

- Remove the bearing (if fitted) from the big end of the connecting rod **4**.
- Mount the connecting rod **4** on the base **D** and lock it in position with the bracket **E** and plate **H**.
- Position the puller **F** and collar **G** as shown in the illustration. Then, slowly apply pressure of approximately 49 kN (5,000 kgf) until the connecting rod bushing **3** is pressed out.

[Installation]

- Apply engine oil to the small end of the connecting rod **4** and to the outer surface of the connecting rod bushing **3**.
- Fit the collar **J** over the puller **F**, position the connecting rod bushing **3** and collar **G** as shown in the illustration, and lock this arrangement together with the nut **K**.
- Align the oil holes **L** in the small end of the connecting rod bushing **3** and connecting rod **4**. Then, use a press to slowly apply pressure of approximately 49 kN (5,000 kgf) until the bushing is pressed into place.
- After press-fitting the connecting rod bushing **3**, ream it to achieve the specified nominal clearance between the bushing and piston pin **2**.

**NOTE**

After installing the connecting rod bushing **3**, insert the piston pin **2** and check that it turns smoothly and without play.

## Piston pin, connecting rod, and piston

[Removal]

- Tap out the piston pin **2** using a rod and hammer.
- If the piston pin **2** is difficult to remove, heat the piston **8** in hot water or using a piston heater.

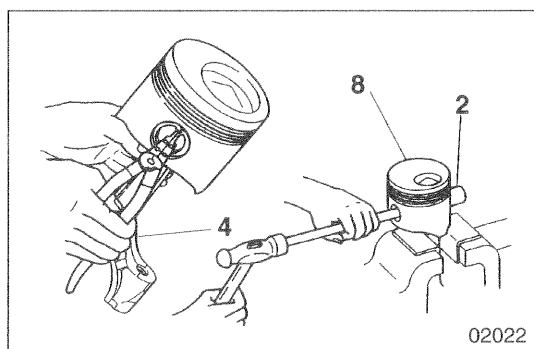
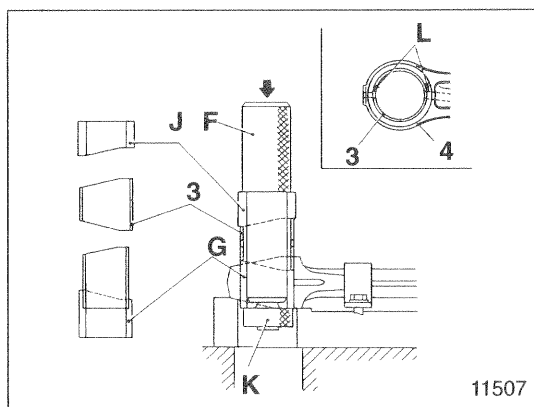
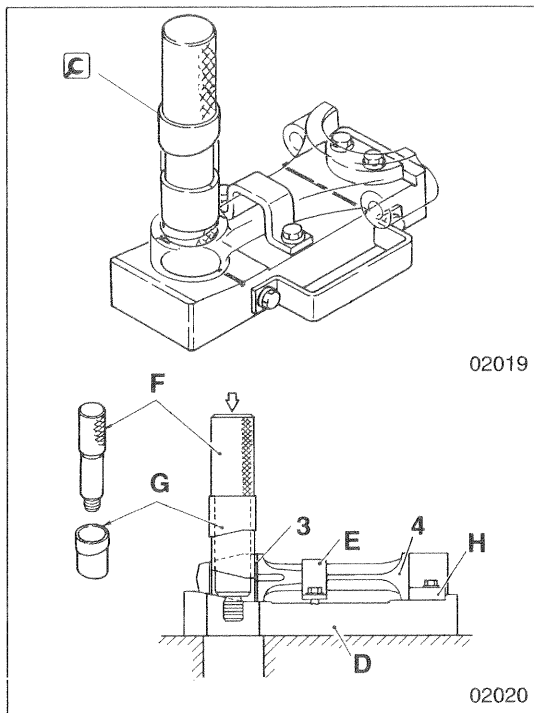

# PISTONS, CONNECTING RODS, AND CYLINDER LINERS

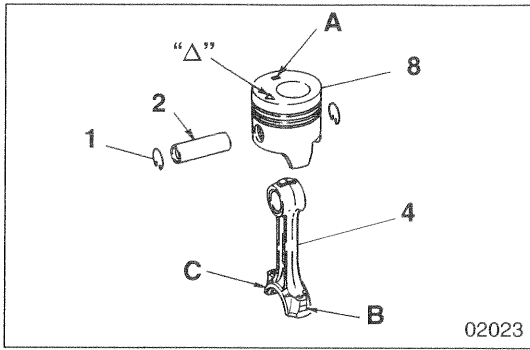

[Installation]

- Apply engine oil to the piston pin 2. With the connecting rod 4 and piston 8 aligned as illustrated, insert the piston pin to hold these components together.

A: Weight mark

B: Weight mark (A, B, C, D, E, F, G, H, I, V, W, X, Y, Z)

C: Alignment mark for connecting rod cap

Δ: Front mark

- If the piston pin 2 is difficult to insert, heat the piston 4 in hot water or using a piston heater.

## CAUTION

- No piston should differ from any other piston by a weight of more than 10g.
- The connecting rods must all have the same weight mark.
- After inserting the piston pin 2, check that it turns smoothly and without play.

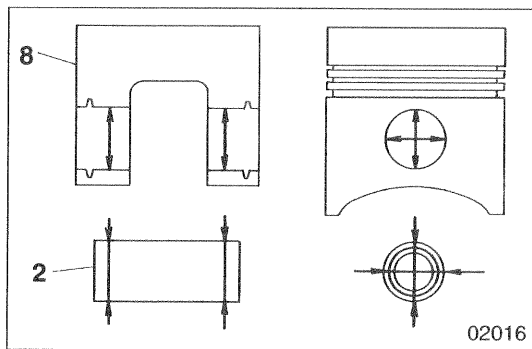

## 2 8 Piston pin-to-piston clearance

If the clearance exceeds the specified limit, replace the defective part(s).

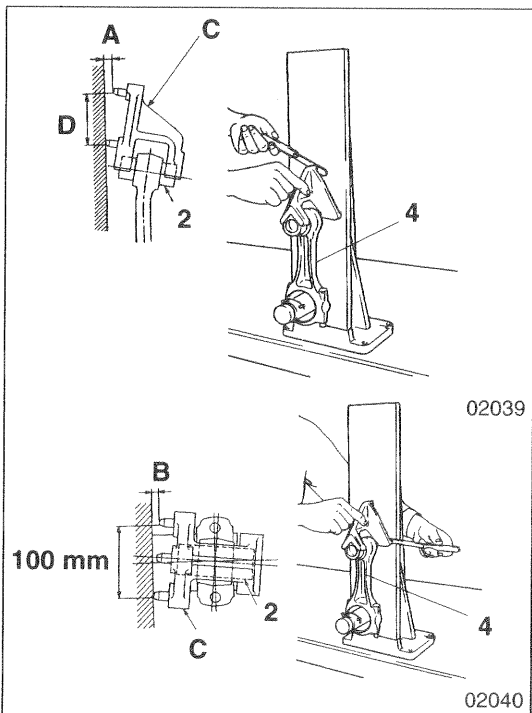

## 4 Connecting rod bend and twist

- Fit the connecting rod bushing 3 and piston 2 in their respective positions of the connecting rod 4.
- Measure the extent of bending A and twisting B in the connecting rod 4.
- If either measurement exceeds the specified limit, replace the connecting rod 4 or rectify it.

C: Connecting rod 4 aligner (measurement device)

## NOTE

- Before mounting the connecting rod 4 on the connecting rod aligner C, install the upper and lower connecting rod bearings in their respective positions.
- Measurements must be made with the connecting rod cap mounting nuts tightened to their specified torque.  P.11-29

**5 to 8** Piston rings and piston

**Piston rings**

[Removal]

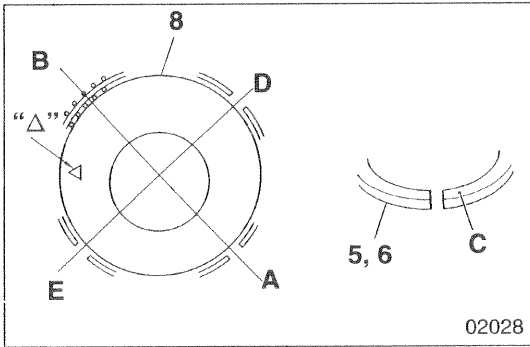
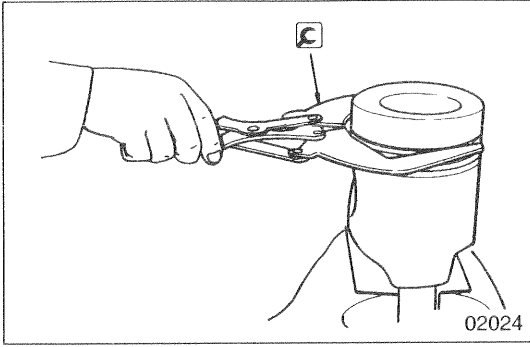

[Installation]

- Fit the oil ring 7 onto the piston 8 with its side rail gaps **A** and the expander spring gap **B** in the positions illustrated.
- Fit the compression rings 5, 6 onto the piston such that the manufacturer's marks **C** near the gaps face upward.
- Align the compression ring gaps **D, E** as illustrated.

**D**: 1st compression ring gap  
**E**: 2nd compression ring gap  
**Δ**: Front mark

[Inspection]

**(1) Piston ring end gap**

- Using the crown of a piston **8**, push the piston ring **5, 6 or 7** horizontally into a cylinder liner **F** for measurement.
- Taking care not to move the piston ring **5, 6 or 7**, measure the end gap. Replace all the rings of a piston if any gap exceeds the specified limit.

**NOTE**

- To keep the piston ring 5, 6 or 7 horizontal, be sure to insert them into the cylinder liner **F** using a piston **8**.
- Push the piston ring 5, 6 or 7 down to the bottom of cylinder liner **F**; the bottom should be less worn than the top.
- Piston rings 5, 6 or 7 must be replaced as a set. Never replace piston rings individually.

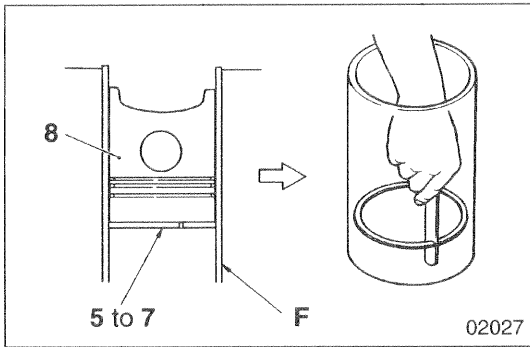

# PISTONS, CONNECTING RODS, AND CYLINDER LINERS

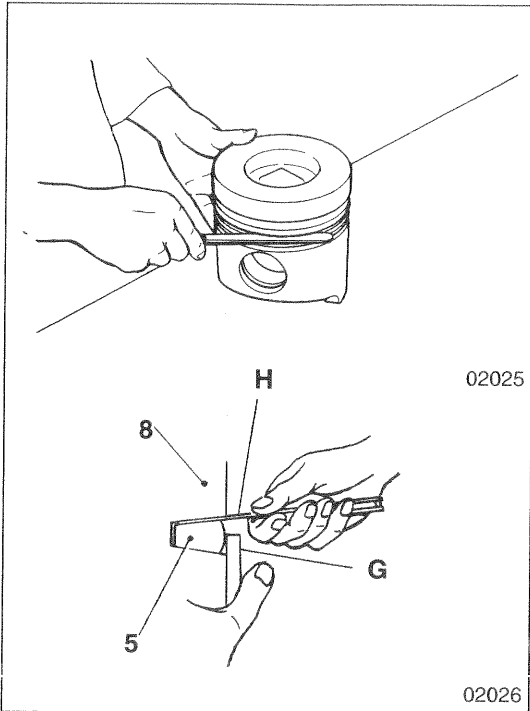

## (2) Piston ring-to-piston ring groove clearance

- If any measurement exceeds the specified limit, replace the defective part(s).
- Measure the 1st compression ring 5 clearance with a thickness gauge **H** while pressing the ring against the piston **8** with a straight edge **G**.

### NOTE

- Remove any carbon deposits from the ring groove of the piston **8** and measure the clearance around the piston's entire periphery.
- Piston rings **5, 6, 7** must be replaced as a set. Never replace piston rings individually.

---

# MEMO

---

# FLYWHEEL PTO

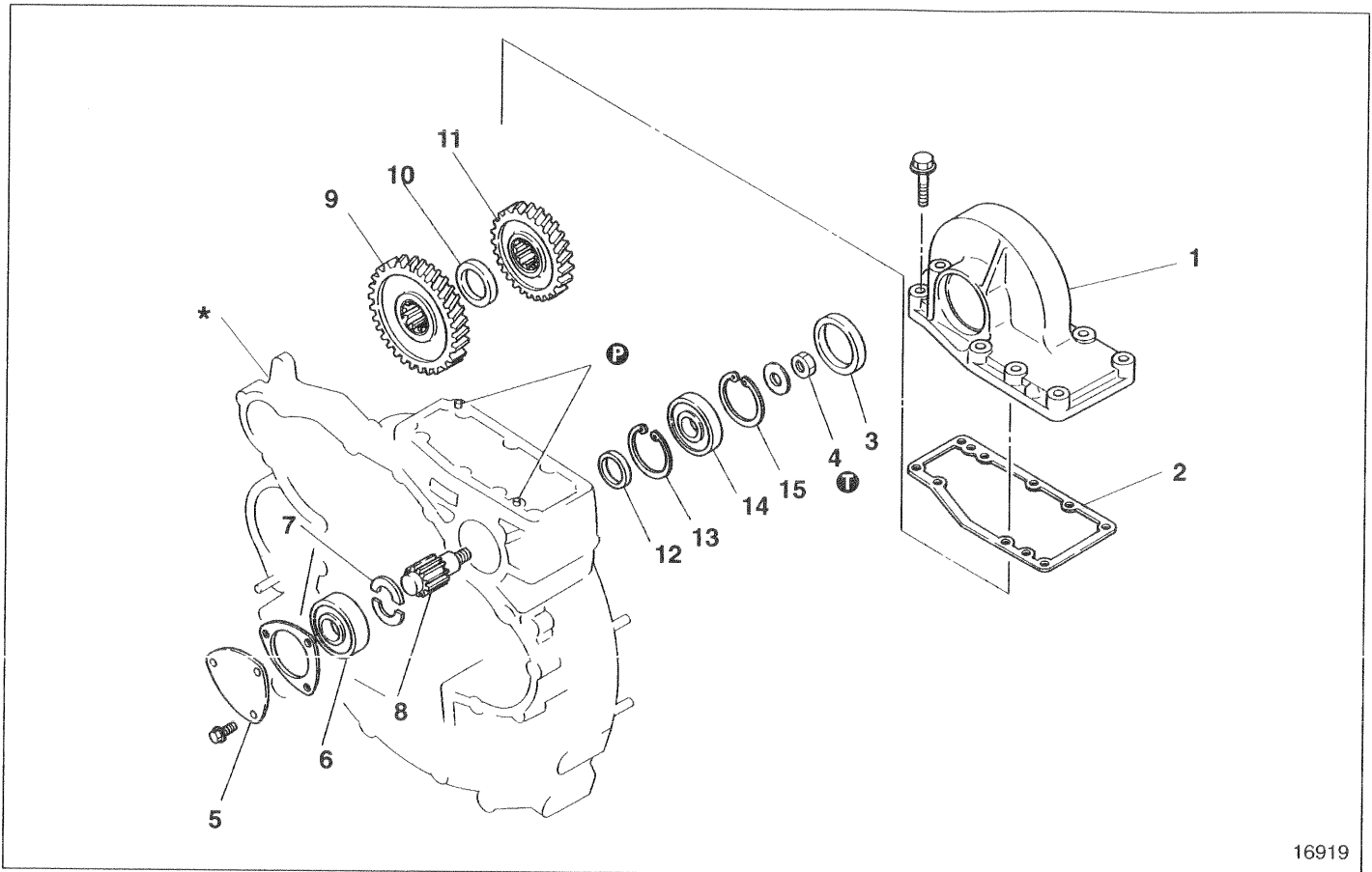

## ● Pre-disassembly inspection

📖 P.11-45

## ● Disassembly sequence

- 1 Flywheel PTO head assembly 📖 P.11-46
- 2 Shim
- 3 Seal cap
- 4 Nut
- 5 Cover
- 6 Ball bearing
- 7 Cotter
- 8 PTO idler shaft
- 9 PTO idler gear A

- 10 Spacer
- 11 PTO idler gear B
- 12 Spacer
- 13 Snap ring
- 14 Ball bearing
- 15 Snap ring

Ⓟ: Locating pin

\*: Flywheel housing 📖 P.11-48

## ● Assembly sequence

Reverse the order of disassembly.

## Service standards

Unit: mm

Location	Maintenance item		Standard value	Limit	Remedy	
—	Gear backlash	Between PTO idler gear A and No. 1 idler gear	6D16, 16-E	0.08 to 0.20	0.35	Reference value
			6D16-T, 16-TE	0.12 to 0.26	0.35	
		Between PTO gear and idler gear B	6D16, 16-E	0.08 to 0.20	0.35	Reference value
			6D16-T, 16-TE	0.12 to 0.26	0.35	
		Total PTO gear backlash		0.18 to 0.35	—	Rectify or replace

## ① Tightening torques

Unit: N·m {kgf·m}

Location	Parts to be tightened	Tightening torque	Remarks
4	PTO idler shaft mounting nut	125 {12.8}	—

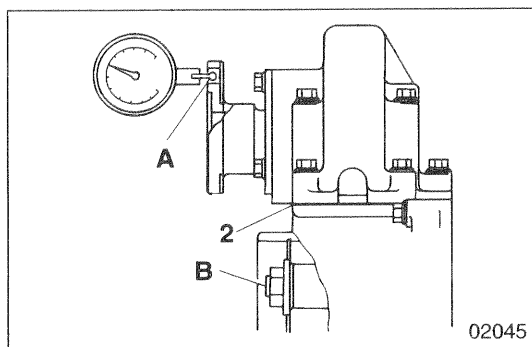

## ◆ Service procedure

## ● Pre-disassembly inspection

## Gear backlash

- Measurement of the backlash between PTO idler gear **A** and No. 1 idler gear and of the total backlash should be carried out at the  $\phi 100$  pitch circle on the PTO flange **A**. If backlash is out of specification, adjust it using a shim **2**.

Shims are available in the following sizes:

0.1 mm, 0.2 mm, and 0.3 mm.

- Measurement of the backlash between the PTO gear and PTO idler gear **B** should be carried out at the  $\phi 100$  pitch circle on the PTO flange. Hold the PTO idler shaft **B** steady while taking measurements. If the backlash is out of specification, adjust it using a shim **2**.

Shims are available in the following sizes:

0.1 mm, 0.2 mm, and 0.3 mm.

# FLYWHEEL PTO

## Flywheel PTO Head Assembly

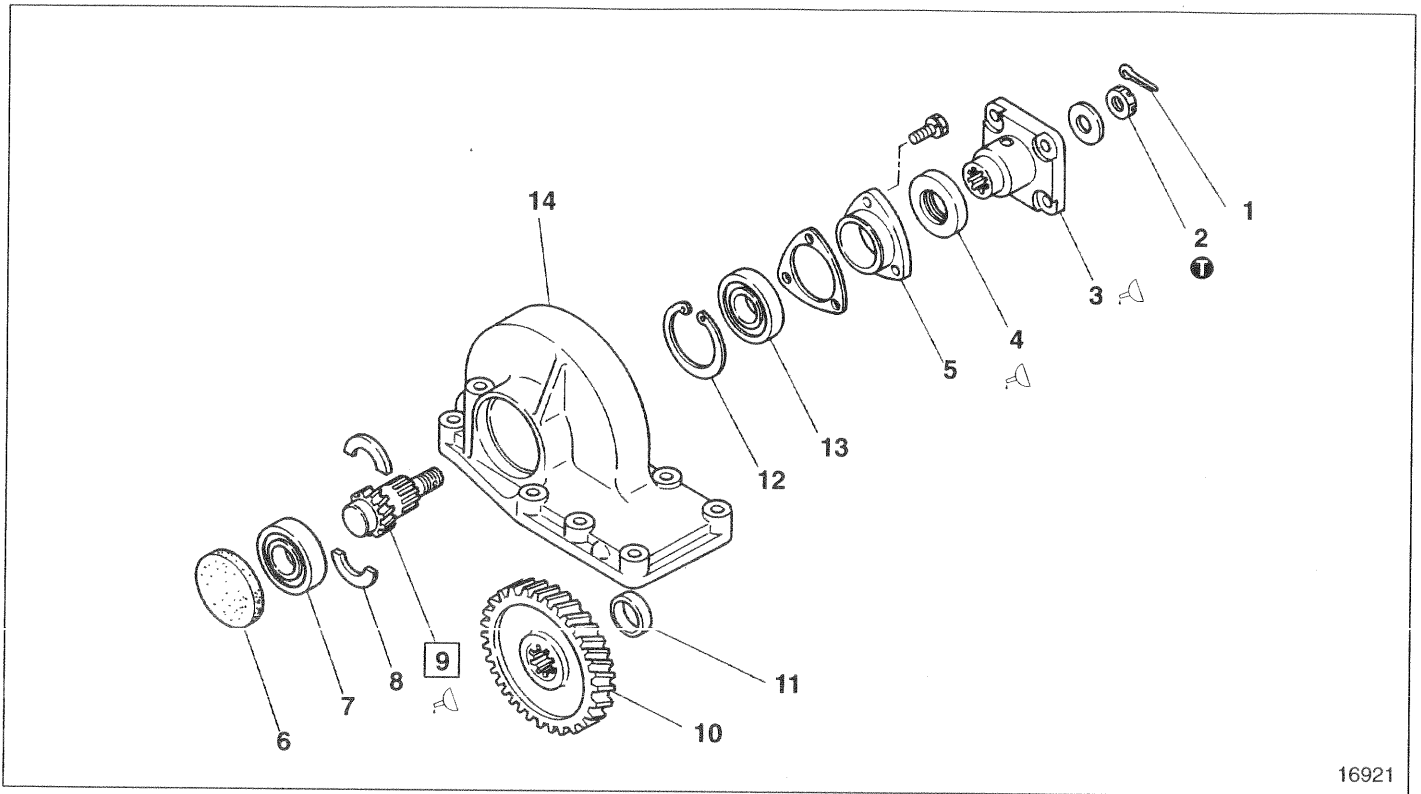

16921

### ● Disassembly sequence

- |              |                |                 |
|--------------|----------------|-----------------|
| 1 Split pin  | 6 Seal cap     | 11 Spacer       |
| 2 Nut        | 7 Ball bearing | 12 Snap ring    |
| 3 Flange     | 8 Cotter       | 13 Ball bearing |
| 4 Oil seal   | 9 PTO shaft    | 14 Cover        |
| 5 Rear cover | 10 PTO gear    |                 |

### ● Assembly sequence

Opposite of disassembly sequence.

### Service standards

Unit: mm

Location	Maintenance item	Standard value	Limit	Remedy
—	PTO shaft end play	0 to 0.8	—	Replace

### ① Tightening torques

Unit: N·m {kgf·m}

Location	Parts to be tightened	Tightening torque	Remarks
2	Flange mounting nut	125 {12.8}	—

### 🔧 Lubricant

Location	Points of application	Specified lubricant	Quantity
3	Flange splines	Wheel bearing grease [NLGI N0.2 (Li soap)]	As required
4	Oil seal lip	Wheel bearing grease [NLGI N0.2 (Li soap)]	As required
9	PTO shaft splines	Wheel bearing grease [NLGI N0.2 (Li soap)]	As required

**◆ Service procedure****● Pre-disassembly inspection****PTO shaft end play**

If the measurement exceeds the specified limit, replace the defective part(s).

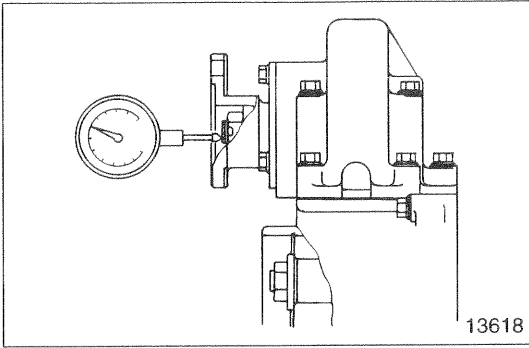
**9 Removing PTO shaft**

**A**: Plastic mallet

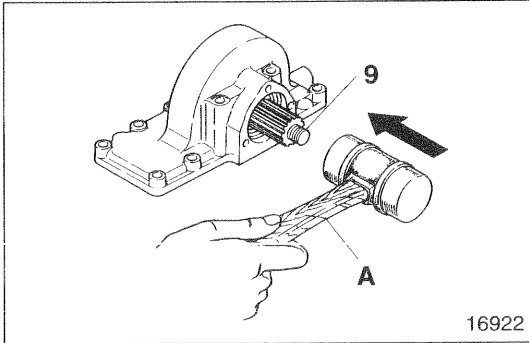

# FLYWHEEL

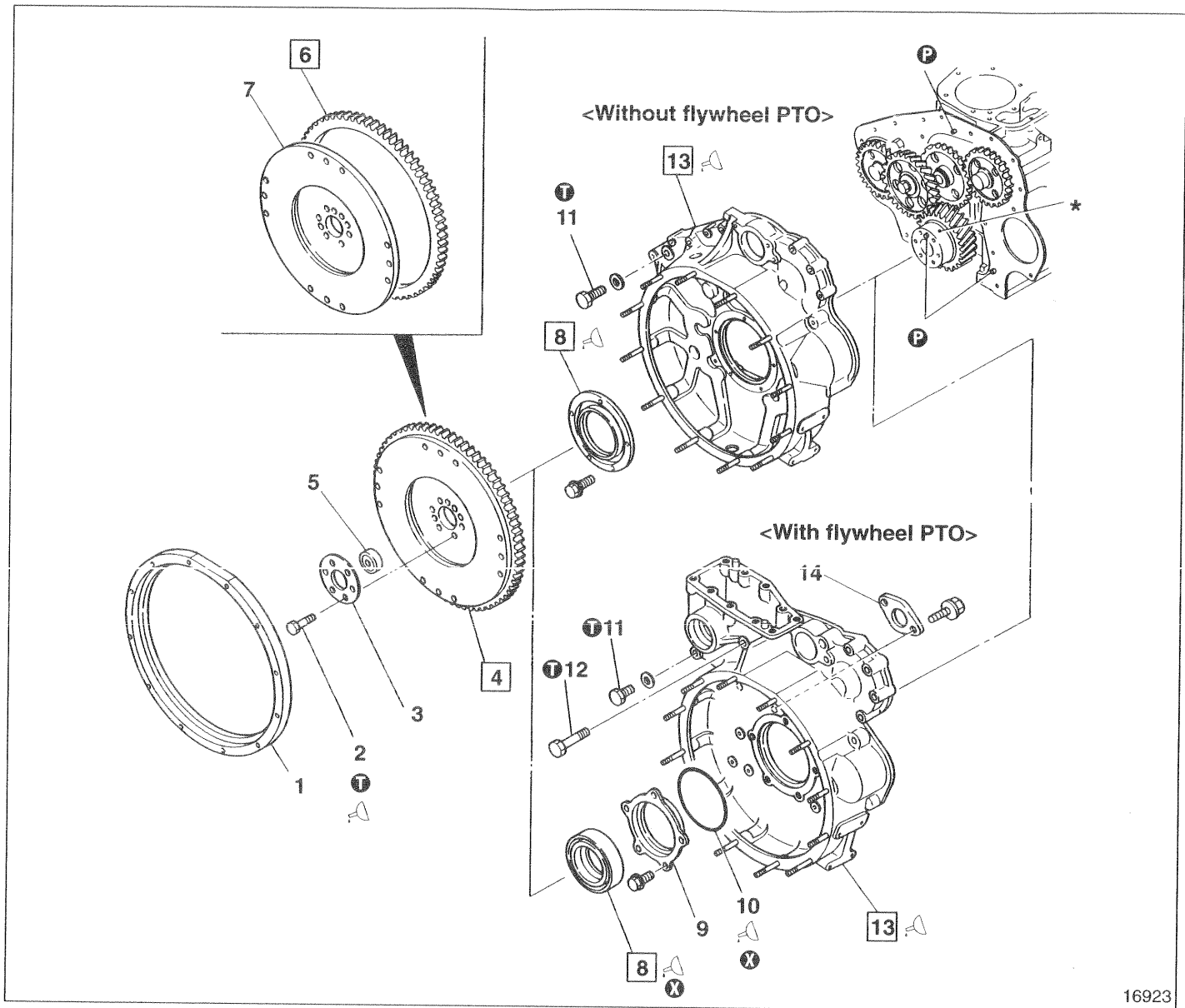

16923

## ● Disassembly sequence

- 1 Spacer
- 2 Bolt
- 3 Washer plate
- 4 Flywheel assembly
- 5 Pilot bearing
- 6 Ring gear
- 7 Flywheel
- 8 Rear oil seal
- 9 Rear oil seal retainer <models with flywheel PTO>

- 10 O-ring <models with flywheel PTO>
- 11 Plug
- 12 Bolt <models with flywheel PTO>
- 13 Flywheel housing
- 14 Thrust plate <models with flywheel PTO>

\*: Crankshaft P.11-72

P: Locating pin

X: Non-reusable part

## ● Assembly sequence

Reverse the order of disassembly.

## Service standards

Unit: mm

Location	Maintenance item	Standard value	Limit	Remedy	
4	Flywheel assembly	Friction surface distortion	0.05 or less	0.2	Correct or replace
		Height of friction surface	20	19	Replace
		Friction surface runout (when fitted)	—	0.2	Correct or replace
13	Eccentricity of joint	—	0.2	Inspect or replace	

## ⓘ Tightening torques

Unit: N · m {kgf · m}

Location	Parts to be tightened	Tightening torque	Remarks
2	Flywheel mounting bolt	98 {10} + 150°	<ul style="list-style-type: none"> <li>Wet</li> <li>Can be reused up to 3 times</li> <li>📖 P.11-50</li> </ul>
11	Plug	88 {9}	—
12	Bolt <models with flywheel PTO>	34 {3.5}	—

## 🔧 Lubricant and/or sealant

Location	Points of application	Specified lubricant and/or sealant	Quantity
2	Bolt threads	Engine oil	As required
8	Rear oil seal lip	Engine oil	As required
	Flywheel mounting surface of rear oil seal <models without flywheel PTO>	Threebond 1207C	As required
10	O-ring	Engine oil	As required
13	Engine mounting surface of flywheel housing	Threebond 1207C	As required

## 🔧 Special tools

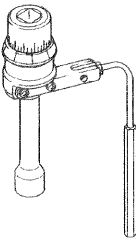
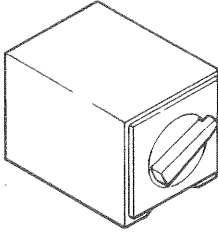
Location	Tool name and shape	Part No.	Application
4	Socket Wrench  01984	MH062354	Fitting flywheel
	Magnetic Base  00471	MH062356	

# FLYWHEEL

## ◆ Service procedure

### 4 Flywheel assembly

[Removal]

To remove the flywheel assembly 4, screw the mounting bolts 2 into the removal holes A.

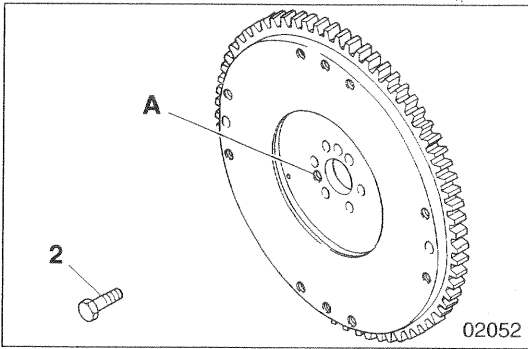

[Installation]

### CAUTION ⚠

Before installing the bolt 2, check the number of punch marks K on its head. (If there are two or less, the bolt is reusable.) The number of punch marks corresponds with the number of times a bolt has been tightened by the plastic region tightening method. If there are three (which means that the bolt has been tightened 3 times), replace the bolt.

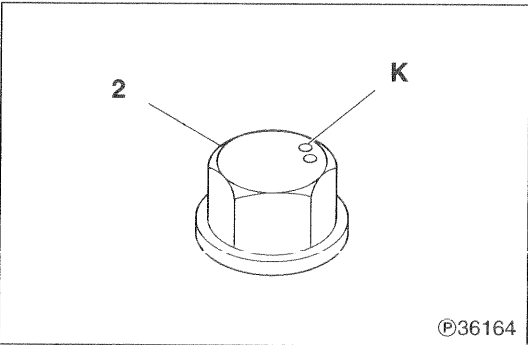

- Tighten the bolts 2 to their specified torque, then tighten them further in accordance with the following procedure:
- Turn the holder B of the Socket Wrench counter-clockwise to tension the built-in spring.

C: Socket  
D: Rod  
E: Rod (extension)

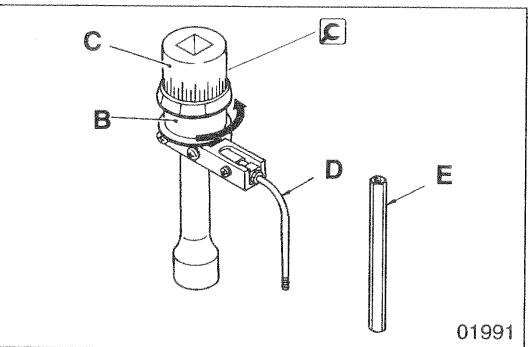

- Set the socket wrench such that the built-in spring forces the rod E against the Magnetic Base.
- On the holder B, select the inscribed line F that is easiest to see.
- Using the selected line as a reference, turn the socket 150° clockwise. (One gradation on the scale G represents 5°.)

### CAUTION ⚠

Since the bolts 2 utilize the plastic region tightening method, they must not be tightened further after this procedure.

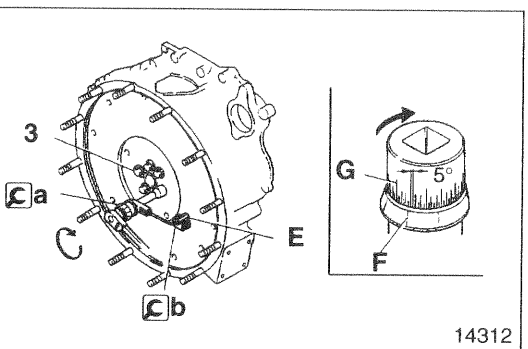

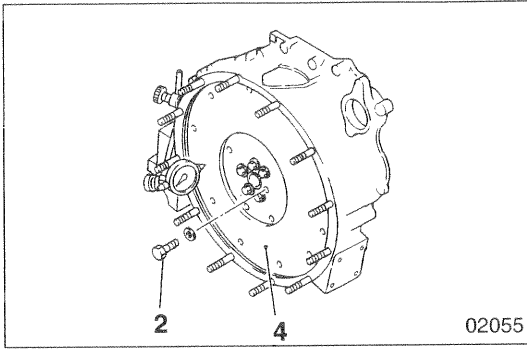

[Inspection]

**(1) Runout**

- Tighten the bolts 2 to their specified torque.
- If runout exceeds the specified limit, check that the bolts 2 are tightened correctly and inspect the crankshaft\* mounting surface. Then, rectify or replace the flywheel assembly 4 as required.

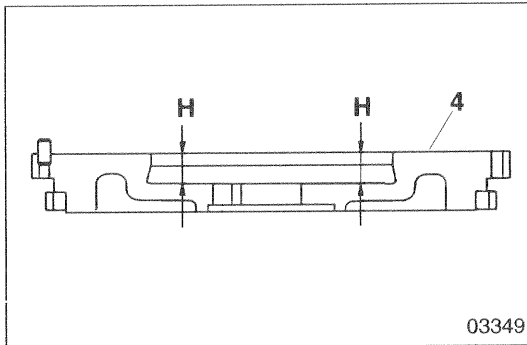

**(2) Height of friction surface**

If the measurement is below the specified value, rectify or replace the flywheel assembly 4.

**H:** Height of friction surface

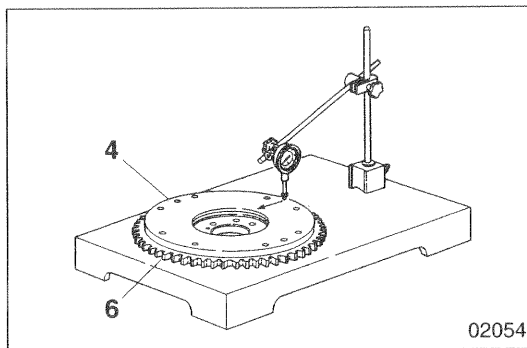

**(3) Distortion of friction surface**

If distortion exceeds the specified limit, rectify or replace the flywheel assembly 4.

**NOTE**

If any abnormality is evident on the ring gear 6, replace the ring gear before making inspections.

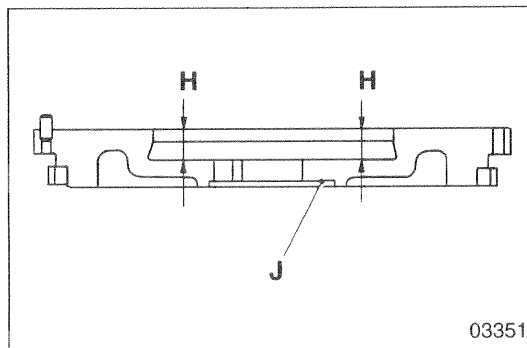

[Rectification]

Grind the friction surface such that its height **H** remains greater than the specified minimum. The friction surface must remain parallel with surface **J** with a tolerance of 0.1 mm.

**6 Ring gear**

[Inspection]

Inspect the ring gear 6 for damage and abnormal wear. If any defect is evident, the ring gear must be replaced.

# FLYWHEEL

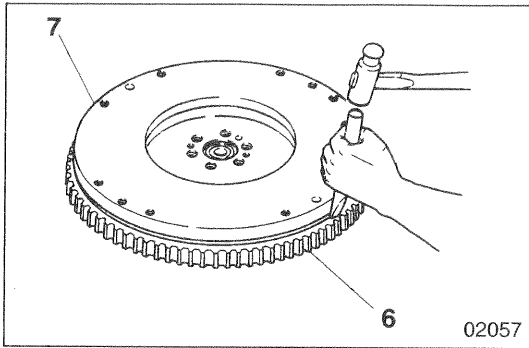

[Removal]

- Heat the ring gear 6 evenly with an acetylene torch or the like.

**CAUTION** ⚠

Be careful not to get burned.

- Remove the ring gear 6 from the flywheel 7 by tapping around its entire periphery.

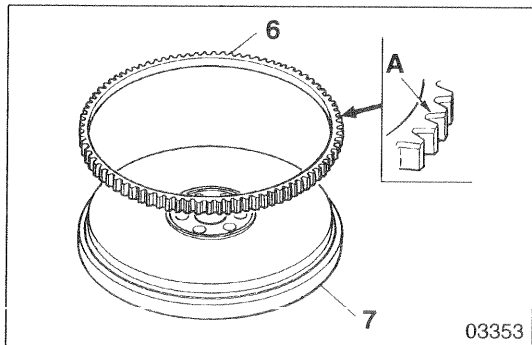

[Installation]

- Using a piston heater or the like, heat the ring gear 6 to approximately 100°C for 3 minutes.

**CAUTION** ⚠

Be careful not to get burned.

- Fit the ring gear 6 with the non-chamfered side of its teeth toward the flywheel 7.

A : Chamfered side of ring gear

## 8 Fitting rear oil seal

<Models without flywheel PTO>

- Apply an even, unbroken bead of sealant A to the rear oil seal 8 in the position illustrated B.
- Fit the rear oil seal 9 onto the flywheel housing 12 within 3 minutes of applying the sealant A.

**CAUTION** ⚠

- Ensure that the sealant application position B on the oil seal 8 is clean before applying sealant.
- When fitting the rear oil seal 8, hold it firmly in position to prevent spreading the sealant.
- After fitting the rear oil seal 8, wait at least 30 minutes before starting the engine.
- Apply a new bead of sealant A whenever the mounting bolts of the rear oil seal 8 have been loosened.

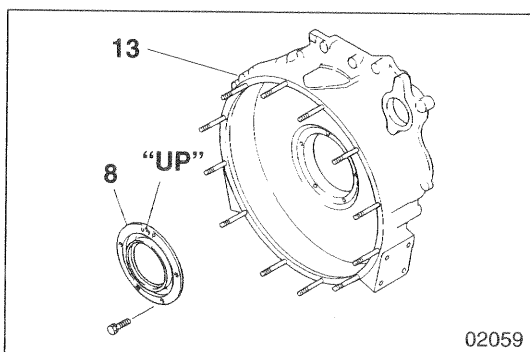
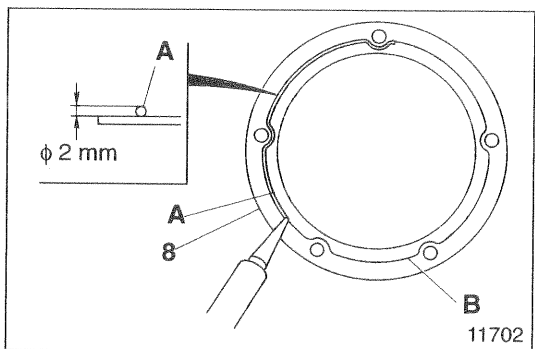

- Apply engine oil to the lip of the rear oil seal 8.
- Fit the rear oil seal 8 onto the flywheel housing 13 in the direction illustrated.

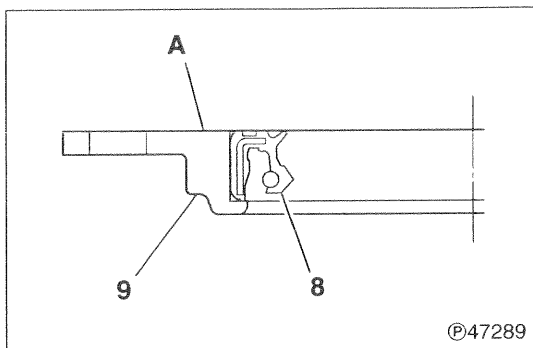

<Models with flywheel PTO>

- Fit the rear oil seal **8** into the rear oil seal retainer **9** in the direction illustrated by pushing its periphery evenly until the end **A** becomes flush with the end surface of the rear oil seal retainer **9** all around.

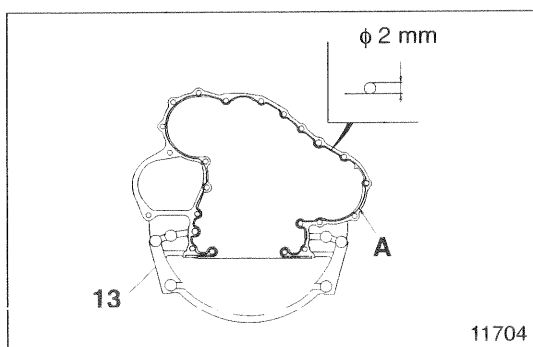

### 13 Flywheel housing

[Installation]

- Apply an even, unbroken bead of sealant **A** to the crankcase mounting surface of the flywheel housing **13**.
- Fit the flywheel housing **13** onto the crankcase within 3 minutes of applying the sealant **A**.

### CAUTION

- Ensure that the sealant application position on the flywheel housing **13** is clean before applying sealant.
- When fitting the flywheel housing **13**, hold it firmly in position to prevent spreading the sealant.
- After fitting the flywheel housing **13**, wait at least an hour before starting the engine.
- Apply a new bead of sealant **A** whenever the mounting bolts of the flywheel housing **13** have been loosened.

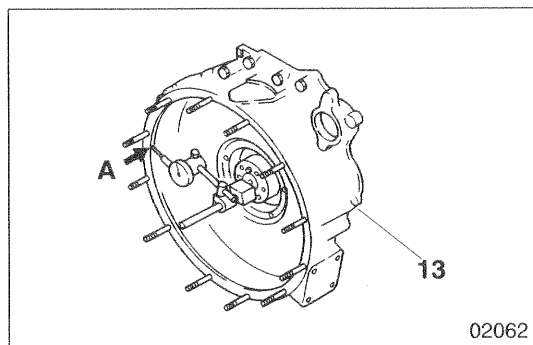

[Inspection]

- Rotate the crankshaft and check the extent of eccentricity at the joint **A** of the flywheel housing **13**.
- If eccentricity exceeds the specified limit, carry out reassembly.
- If eccentricity still exceeds the specified limit after reassembly, replace the defective part(s).

# TIMING GEARS

<Without Flywheel PTO>

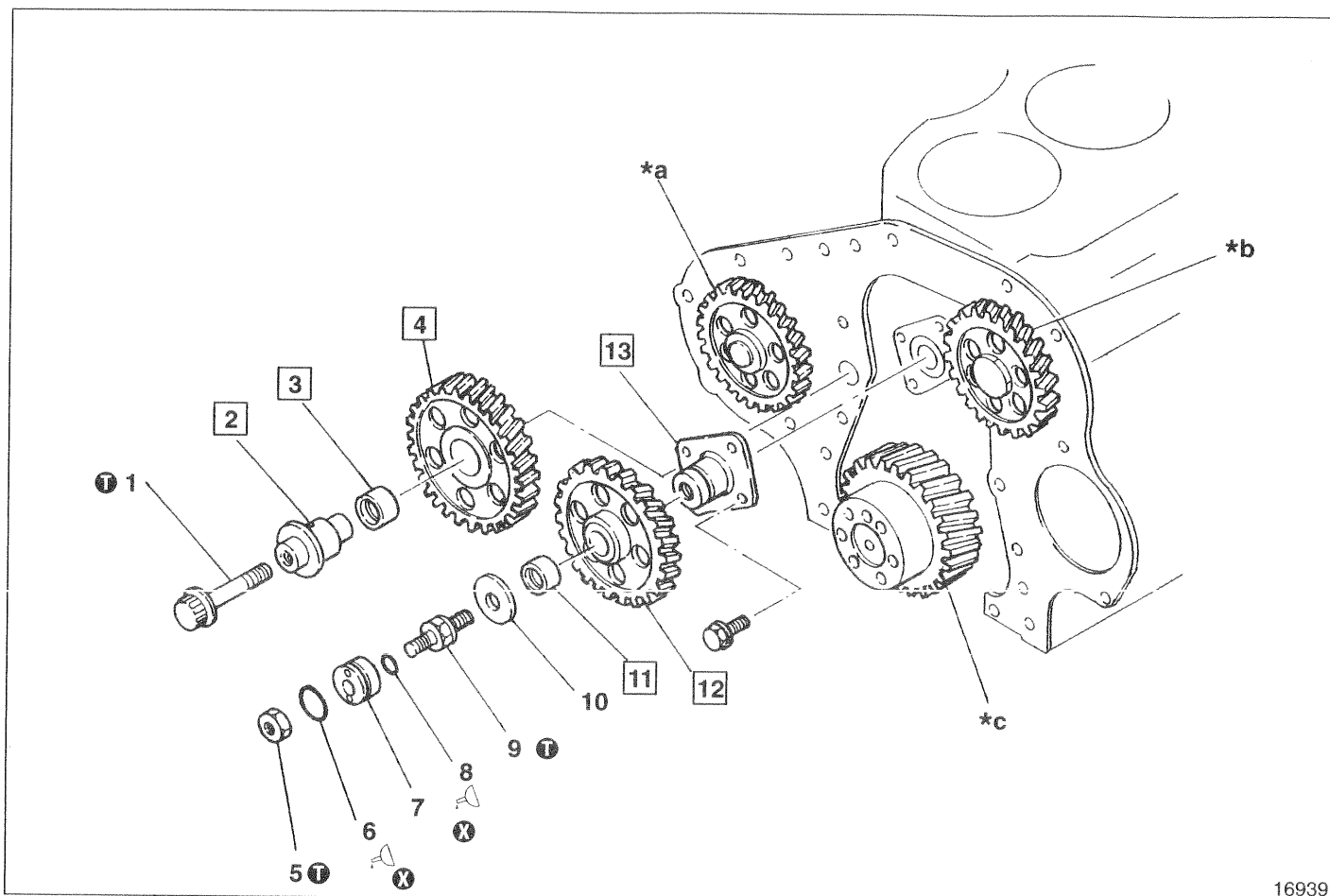

16939

## ● Pre-disassembly inspection

📖 P.11-56

## ● Disassembly sequence

- |                            |                               |
|----------------------------|-------------------------------|
| 1 Bolt                     | 10 Thrust washer              |
| 2 No. 1 idler shaft        | 11 No. 2 idler gear bushing   |
| 3 No. 1 idler gear bushing | 12 No. 2 idler gear           |
| 4 No. 1 idler gear         | 13 No. 2 idler shaft          |
| 5 Nut                      |                               |
| 6 O-ring                   | *a: Drive gear                |
| 7 Collar                   | *b: Camshaft gear 📖 P.11-64   |
| 8 O-ring                   | *c: Crankshaft gear 📖 P.11-72 |
| 9 Bolt                     |                               |

ⓧ: Non-reusable part

## CAUTION ⚠

Since the No. 1 idler gear 4 is supported by the No. 1 idler shaft 2, these parts must be removed as a single unit.

## ● Assembly sequence

Reverse the order of disassembly.

## Service standards

Unit: mm

Location	Maintenance item		Standard value (Basic diameter in [ ])	Limit	Remedy
—	Gear backlash	Between No. 1 idler gear and crankshaft gear	0.08 to 0.15	0.35	Replace
		Between No. 1 idler gear and No. 2 idler gear	0.07 to 0.15	0.35	Replace
		Between No. 1 idler gear and drive gear	0.07 to 0.15	0.35	Replace
		Between No. 2 idler gear and camshaft gear	0.08 to 0.16	0.35	Replace
<b>2, 3</b>	No. 1 idler shaft-to-gear bushing clearance		[37] 0.01 to 0.05	0.2	Replace
<b>4, 12</b>	Idler gear end play		0.05 to 0.15	0.3	Replace
<b>11, 13</b>	No. 2 idler gear bushing-to-shaft clearance		[32] 0.01 to 0.05	0.2	Replace

## ① Tightening torques

Unit: N · m {kgf · m}

Location	Parts to be tightened	Tightening torque	Remarks
<b>1</b>	No. 1 idler gear mounting bolt	88 {9}	—
<b>5</b>	Collar mounting nut	82 {8.4}	—
<b>9</b>	No. 2 idler gear mounting bolt	95 {9.7}	—

## 🔧 Lubricant

Location	Points of application	Specified lubricant	Quantity
<b>6, 8</b>	O-ring	Engine oil	As required

# TIMING GEARS

## Special tools

Unit: mm

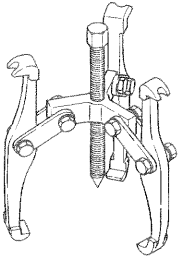
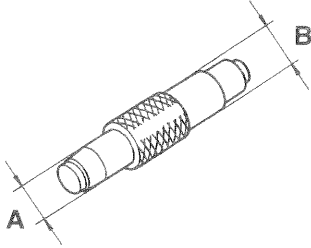
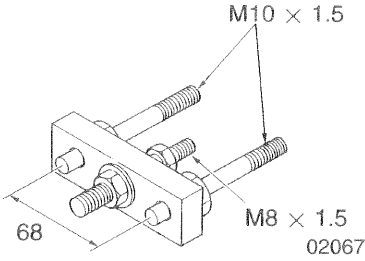
Location	Tool name and shape	Part No.	Application									
2, 4	Gear Puller 	MH061326	Removing No. 1 idler shaft and gear									
3, 11	Idler Gear Bushing Puller <table border="1" data-bbox="215 526 523 766"> <thead> <tr> <th></th> <th>A</th> <th>B</th> </tr> </thead> <tbody> <tr> <td>No. 1 idler gear bushing</td> <td>φ 37</td> <td>φ 40</td> </tr> <tr> <td>No. 2 idler gear bushing</td> <td>φ 32</td> <td>φ 35</td> </tr> </tbody> </table> 		A	B	No. 1 idler gear bushing	φ 37	φ 40	No. 2 idler gear bushing	φ 32	φ 35	<No. 1> MH062601 <No.2> MH061779	Removing and fitting idler gear bushings
	A	B										
No. 1 idler gear bushing	φ 37	φ 40										
No. 2 idler gear bushing	φ 32	φ 35										
13	Idler Shaft Puller 	MH062405	Removing No. 2 idler gear shaft									

### ◆ Service procedure

#### ● Pre-disassembly inspection

##### (1) Gear backlash

For each gear pair, measure backlash at three or more points. If any measurement exceeds the specified limit, replace the defective part(s).

##### (2) Idler gear end play

If the measurement exceeds the specified value, replace the defective part(s).

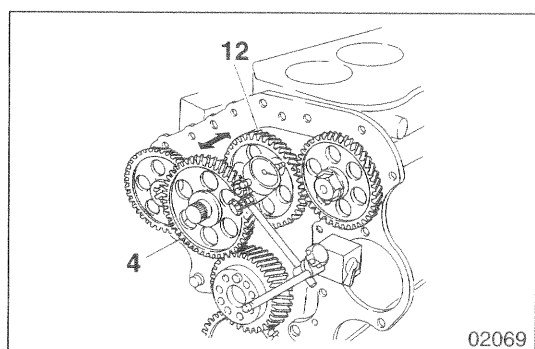
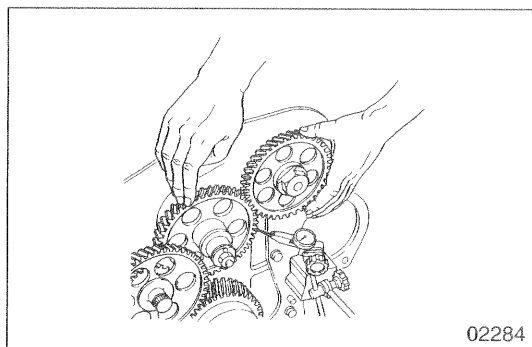

**2 3** No. 1 idler shaft and No. 1 idler gear bushing

[Inspection]

If the clearance exceeds the specified limit, replace the defective part(s).

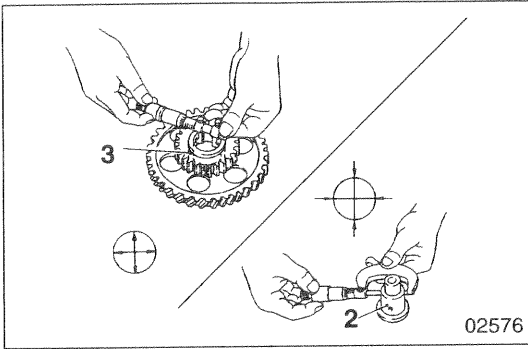
**No. 1 idler gear bushing**

[Removal]

A: Press

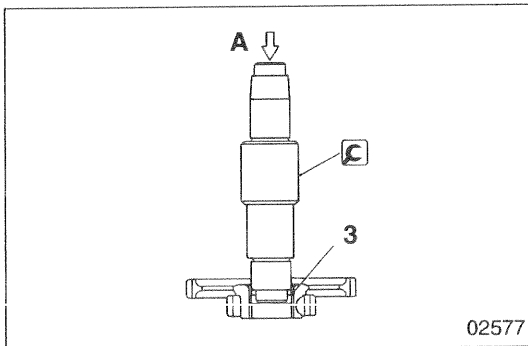

[Installation]

- Using the (C) Idler Gear Bushing Puller, press the No. 1 idler gear bushing 3 into the No. 1 idler gear 4 from the side of the gear whose internal diameter is chamfered B.

A: Press

- After installation, measure the clearance again. If the measurement is below the nominal value range, ream the bushing 3.

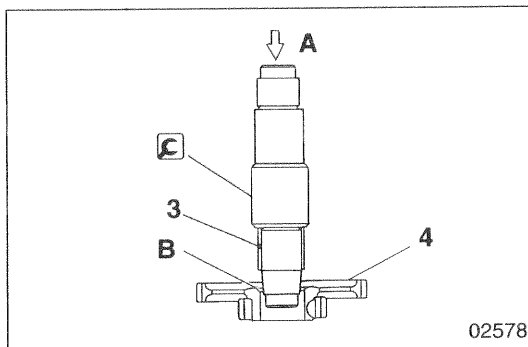
**2 4** Removing No. 1 idler shaft and No. 1 idler gear

Loosen the bolt 1 by approximately 15 mm, then remove the No. 1 idler shaft 2 and No. 1 idler gear 4 as a single unit.

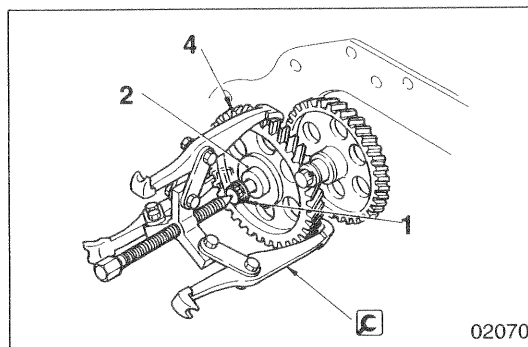
**4 12** Installing No. 1 and No. 2 idler gears

Fit the No. 1 and No. 2 idler gears 4, 12 such that their alignment marks ("1", "2", "3", "4") are aligned with those on the gears with which they mate.

\*a: Drive gear

\*b: Camshaft gear

\*c: Crankshaft gear

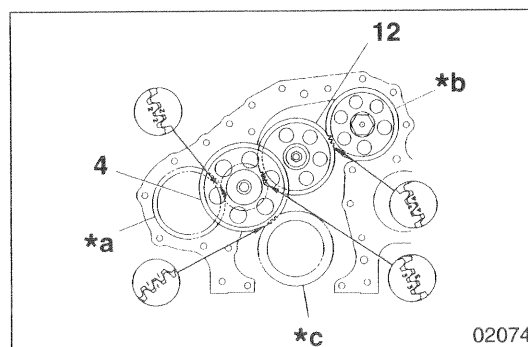

# TIMING GEARS

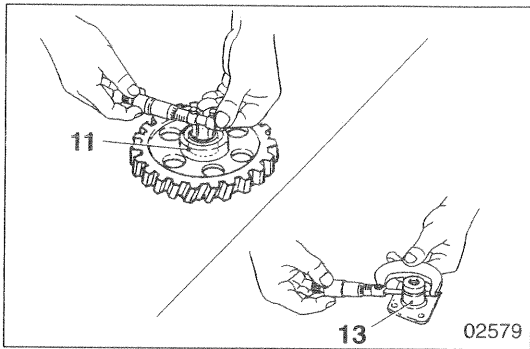

## 11 13 No. 2 idler gear bushing and No. 2 idler shaft

[Inspection]

If the clearance exceeds the specified limit, replace the defective part(s).

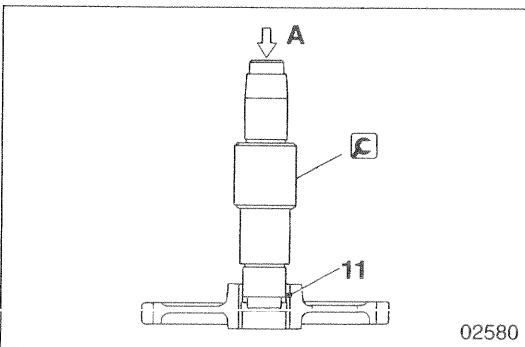

## No. 2 idler gear bushing

[Removal]

A: Press

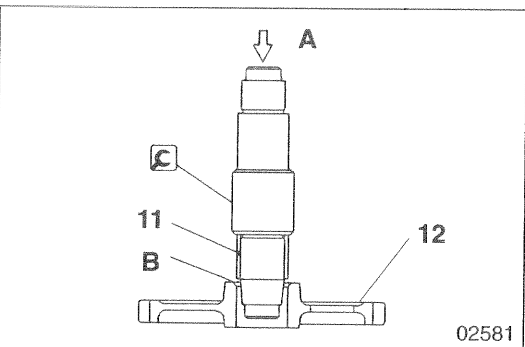

[Installation]

- Using the **C** Idler Gear Bushing Puller, press the No. 2 idler gear bushing **11** into the No. 2 idler gear **12** from the side of the gear whose internal diameter is chamfered **B**.

A: Press

- After installation, measure the clearance again. If the measurement is below the nominal value range, ream the bushing **11**.

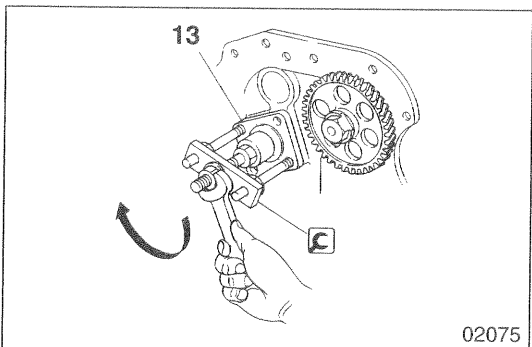

## 13 Removing No. 2 idler shaft

---

**M E M O**

---

# TIMING GEARS

<With Flywheel PTO>

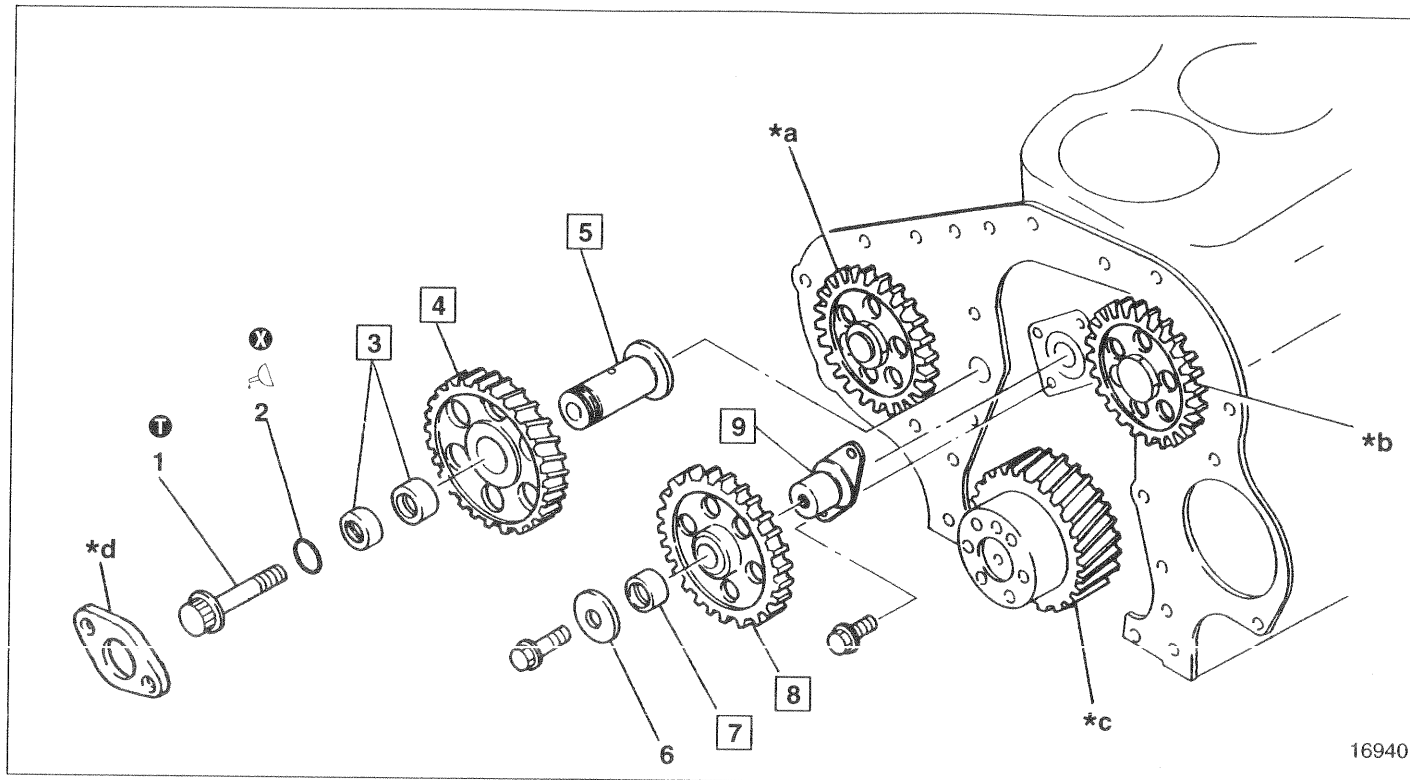

## Disassembly sequence

- |                            |                            |
|----------------------------|----------------------------|
| 1 Bolt                     | 6 Thrust washer            |
| 2 O-ring                   | 7 No. 2 idler gear bushing |
| 3 No. 1 idler gear bushing | 8 No. 2 idler gear         |
| 4 No. 1 idler gear         | 9 No. 2 idler shaft        |
| 5 No. 1 idler shaft        |                            |

- \*a: Drive gear  
 \*b: Camshaft gear P.11-64  
 \*c: Crankshaft gear P.11-72  
 \*d: Thrust plate P.11-48  
 X: Non-reusable part

## Assembly sequence

Reverse the order of disassembly.

## Service standards

Unit: mm

Location	Maintenance item		Standard value (Basic diameter in [ J ])	Limit	Remedy
—	Gear backlash	Between No. 1 idler gear and crankshaft gear	0.07 to 0.20	0.35	Replace
		Between No. 1 idler gear and No. 2 idler gear	0.10 to 0.22	0.35	Replace
		Between No. 1 idler gear and drive gear	0.10 to 0.20	0.35	Replace
		Between No. 2 idler gear and camshaft gear	0.12 to 0.26	0.35	Replace
3, 5	No. 1 idler shaft-to-gear bushing clearance		[40] 0.03 to 0.07	0.2	Replace
4	No. 1 idler gear end play		0.1 to 0.6	1.0	Replace
7, 9	No. 2 idler gear bushing-to-shaft clearance		[32] 0.01 to 0.05	0.2	Replace
8	No. 2 idler gear end play		0.05 to 0.20	0.4	Replace

## ⓘ Tightening torques

Unit: N·m {kgf·m}

Location	Parts to be tightened	Tightening torque	Remarks
1	No. 1 idler gear mounting bolt	135 to 165 {14 to 17}	—

## 🔧 Lubricant

Location	Points of application	Specified lubricant	Quantity
2	O-ring	Engine oil	As required

## 🔧 Special tools

Unit: mm

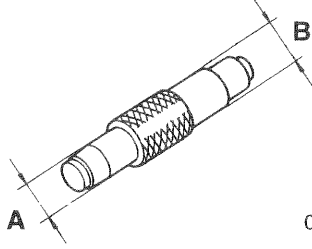
Location	Tool name and shape	Part No.	Application								
3, 7	Idler Gear Bushing Puller										
	<table border="1"> <thead> <tr> <th></th> <th>A</th> <th>B</th> </tr> </thead> <tbody> <tr> <td>No. 1 idler gear bushing</td> <td>φ 40</td> <td>φ 44</td> </tr> <tr> <td>No. 2 idler gear bushing</td> <td>φ 32</td> <td>φ 35</td> </tr> </tbody> </table>  <p style="text-align: right;">02066</p>		A	B	No. 1 idler gear bushing	φ 40	φ 44	No. 2 idler gear bushing	φ 32	φ 35	<No. 1> MH061228 <No.2> MH061779
	A	B									
No. 1 idler gear bushing	φ 40	φ 44									
No. 2 idler gear bushing	φ 32	φ 35									

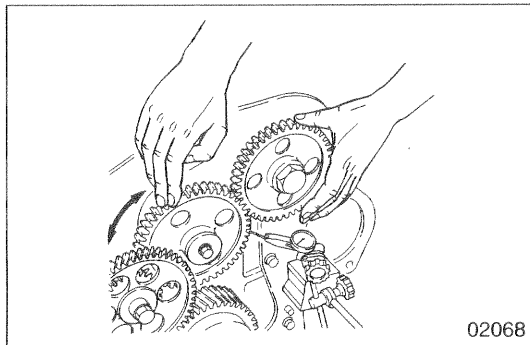

## ◆ Service procedure

### ● Pre-disassembly inspection

#### (1) Gear backlash

For each gear pair, measure backlash at three or more points. If any measurement exceeds the specified limit, replace the defective part(s).

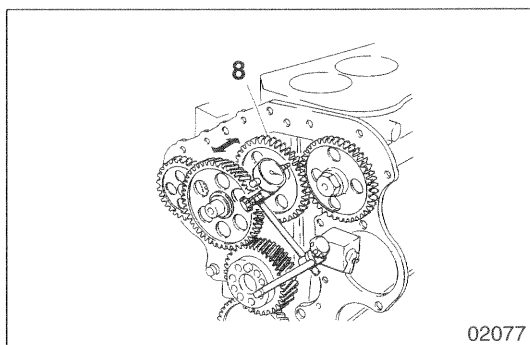

#### (2) No. 2 idler gear end play

If the end play measurement exceeds the specified value, replace the defective part(s).

# TIMING GEARS

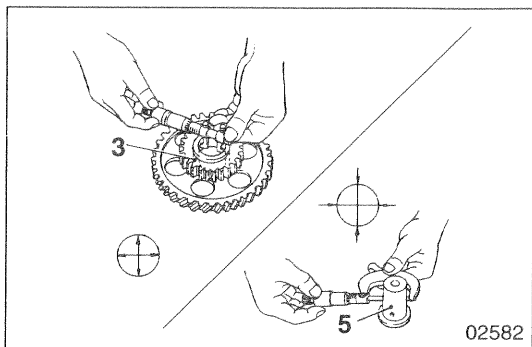

## 3 5 No. 1 idler gear bushing and No. 1 idler shaft

[Inspection]

If the clearance exceeds the specified limit, replace the defective part(s).

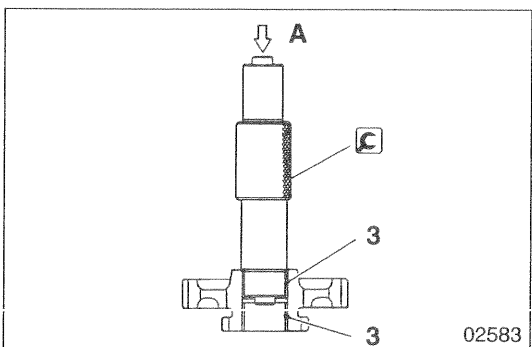

## No. 1 idler gear bushing

[Removal]

The No. 1 idler gear bushing 3 consists of two parts. Press out both parts together.

A: Press

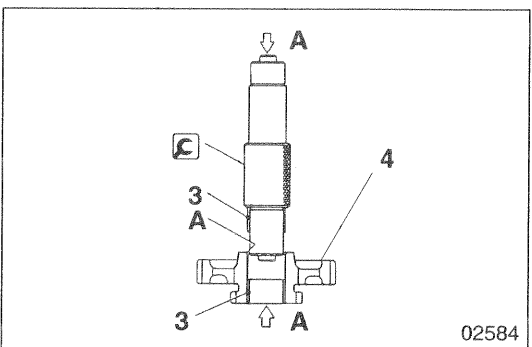

[Installation]

- Using the C Idler Gear Bushing Puller, press each part of the No. 1 idler gear bushing 3 into the No. 1 idler gear 4 from its respective side of the gear.

A: Press

- After installation, measure the clearance again. If the measurement is below the nominal value range, ream the bushing 3.

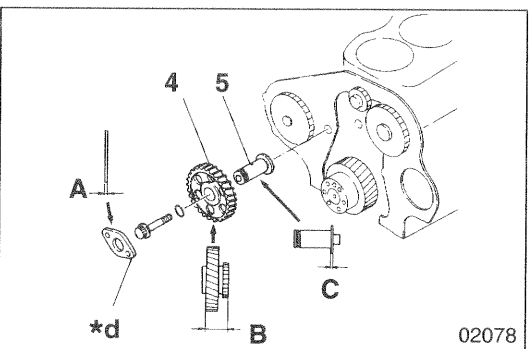

## 4 No. 1 idler gear end play

Measure the dimensions shown in the illustration and determine the end play D using the formula shown below. If the end play exceeds the specified limit, replace the defective part(s).

$$D = 72.15 \text{ mm} - (A + B + C)$$

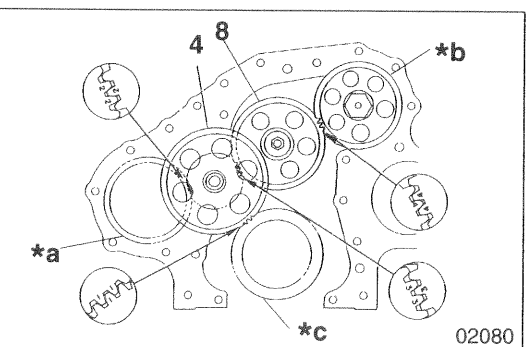

## 4 8 Installing No. 1 and No. 2 idler gears

Fit the No. 1 and No. 2 idler gears 4, 8 such that their alignment marks ("1", "2", "3", "4") are aligned with those on the gears with which they mate.

\*a: Drive gear

\*b: Camshaft gear

\*c: Crankshaft gear

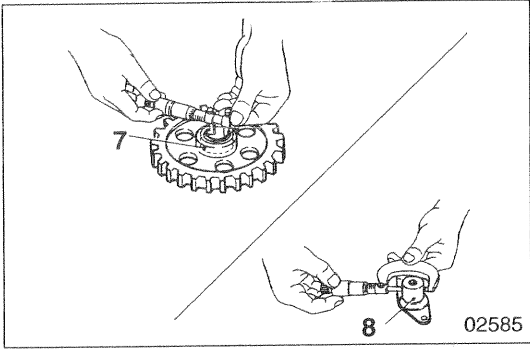

**7 9 No. 2 idler gear bushing and No. 2 idler shaft**

[Inspection]

If the clearance exceeds the specified limit, replace the defective part(s).

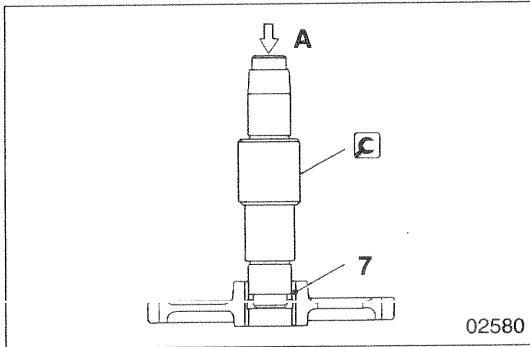

**No. 2 idler gear bushing**

[Removal]

A : Press

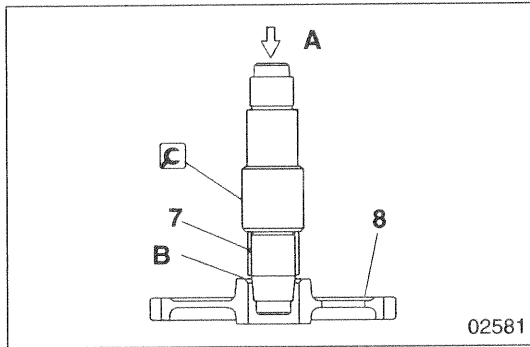

[Press fitting]

- Using the **C** Idler Gear Bushing Puller, press the No. 2 idler gear bushing 7 into the No. 2 idler gear 2 from the side of the gear whose internal diameter is chamfered **B**.

A : Press

- After installation, measure the clearance again. If the measurement is below the nominal value range, ream the No.2 idler gear bushing 7.

# CAMSHAFT

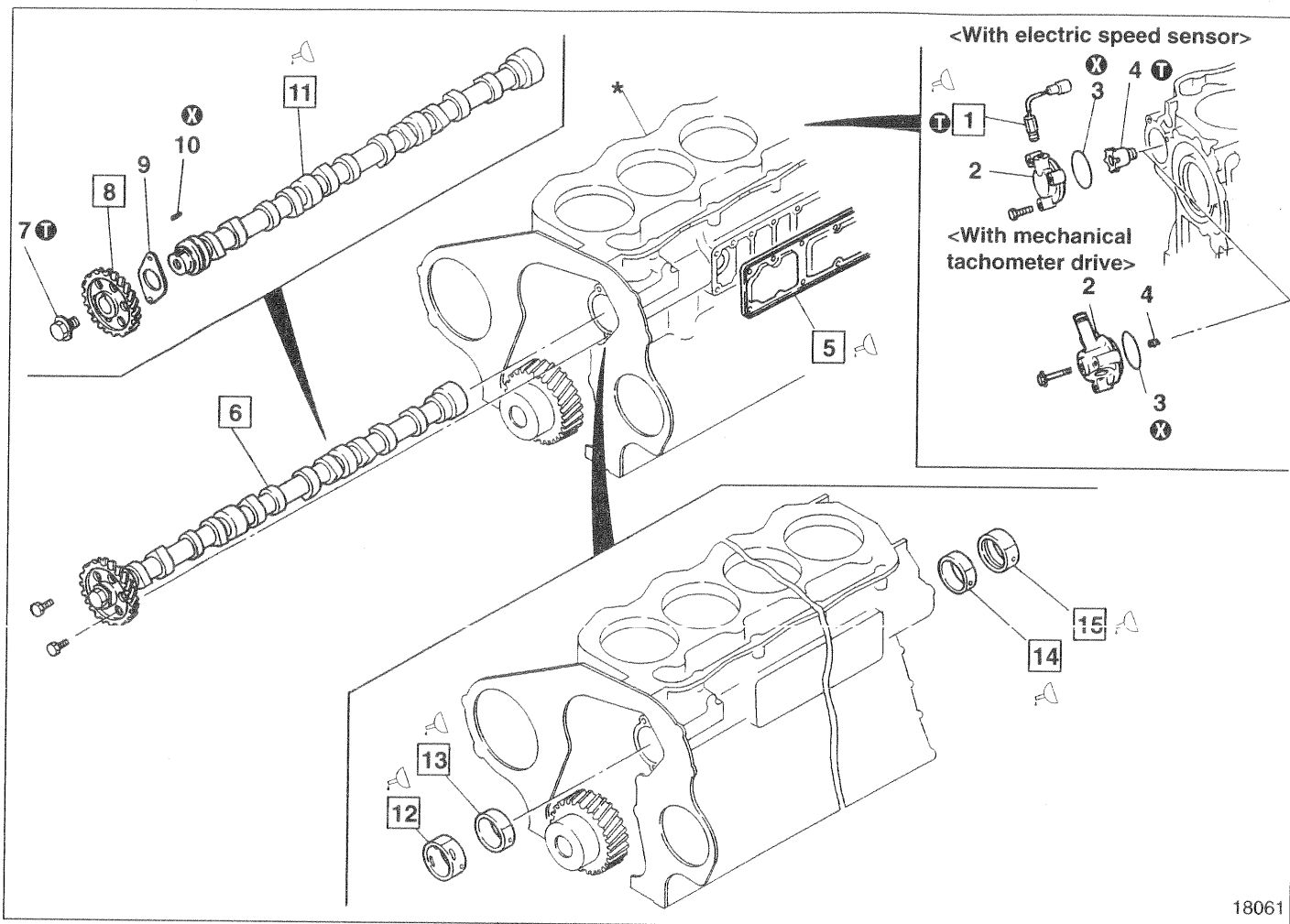

18061

## ● Pre-disassembly inspection

📖 P.11-66

## ● Disassembly sequence

- |  |  |                           |
|--|--|---------------------------|
| 1 Engine speed sensor <models with electric speed sensor>  | 4 Pulse rotor <models with electric speed sensor><br>Tachometer drive coupling <models with mechanical tachometer> | 10 Key                    |
| 2 Adapter <models with electric speed sensor><br>Tachometer drive case <models with mechanical tachometer> | 5 Side cover   | 11 Camshaft               |
| 3 O-ring   | 6 Camshaft assembly  | 12 No. 4 camshaft bushing |
|  | 7 Bolt   | 13 No. 3 camshaft bushing |
|  | 8 Camshaft gear  | 14 No. 2 camshaft bushing |
|  | 9 Thrust plate   | 15 No. 1 camshaft bushing |

\*: Crankcase 📖 P.11-72

⊗: Non-reusable part

## NOTE

- Do not remove the engine speed sensor 1 unless defects are evident.
- Do not remove the camshaft gear 8 unless defects are evident.

## ● Assembly sequence

Reverse the order of disassembly.

## Service standards

Unit: mm

Location	Maintenance item				Standard value (Basic diameter in [ ])	Limit	Remedy
1	Resistance of engine speed sensor (at 25°C)				2.3 ± 0.2 kΩ	—	Replace
6	Camshaft assembly end play				0.05 to 0.22	0.4	Inspect each part
11	Camshaft	Cam lift	Inlet	Except 6D16-E	6.901	6.40	Lobe height: 49.011 Base circle diameter: 42.110
				6D16-E	7.42	6.93	Lobe height: 50.33 Base circle diameter: 42.91
			Exhaust		7.680	7.18	Lobe height: 49.307 Base circle diameter: 41.627
			Bend		0.02 or less	0.04	Replace
11, 12 to 15	Camshaft journal-to-camshaft bushing clearance		No. 1 journal		[57.75] 0.05 to 0.10	0.25	Replace
			No. 2 journal		[58.00] 0.05 to 0.10		
			No. 3 journal		[58.25] 0.13 to 0.18		
			No. 4 journal		[58.50] 0.05 to 0.10		

## ① Tightening torques

Unit: N·m {kgf·m}

Location	Parts to be tightened	Tightening torque	Remarks
1	Engine speed sensor <models with electric speed sensor>	29 ± 5.9 {3.0 ± 0.6}	—
4	Pulse rotor <models with electric speed sensor>	98 {10}	—
7	Camshaft gear mounting bolt	175 {18}	—

## 🔧 Lubricant and/or sealant

Location	Points of application	Specified lubricant and/or sealant	Quantity
1	Engine speed sensor threads <models with electric speed sensor>	Threebond 1104J	As required
5	Crankcase mounting surface of side cover	Threebond 1207C	As required
11	Camshaft journals	Engine oil	As required
12 to 15	Inside surfaces of camshaft bushings	Engine oil	As required

# CAMSHAFT

## Special tools

Unit: mm

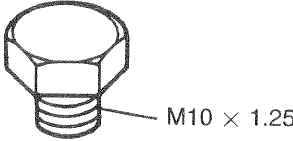
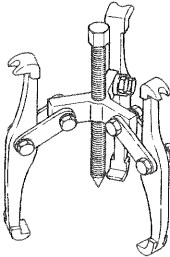
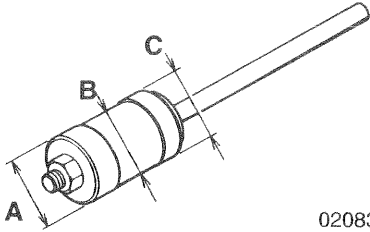
Location	Tool name and shape	Part No.	Application															
8	Plug  M10 x 1.25 02082	MF665007	Blanking plug for use when removing camshaft gear															
	Gear Puller  02065	MH061326	Removing camshaft gear															
12 to 15	Camshaft Bushing Installer and Extractor <table border="1" data-bbox="209 841 547 1067"> <thead> <tr> <th></th> <th>A, C dimension</th> <th>B dimension</th> </tr> </thead> <tbody> <tr> <td>No. 1</td> <td>φ 62.00</td> <td>φ 57.75</td> </tr> <tr> <td>No. 2</td> <td>φ 62.25</td> <td>φ 58.00</td> </tr> <tr> <td>No. 3</td> <td>φ 62.50</td> <td>φ 58.25</td> </tr> <tr> <td>No. 4</td> <td>φ 62.75</td> <td>φ 58.50</td> </tr> </tbody> </table>  02083		A, C dimension	B dimension	No. 1	φ 62.00	φ 57.75	No. 2	φ 62.25	φ 58.00	No. 3	φ 62.50	φ 58.25	No. 4	φ 62.75	φ 58.50	MH062025	Removing and installing camshaft bushings
		A, C dimension	B dimension															
No. 1	φ 62.00	φ 57.75																
No. 2	φ 62.25	φ 58.00																
No. 3	φ 62.50	φ 58.25																
No. 4	φ 62.75	φ 58.50																

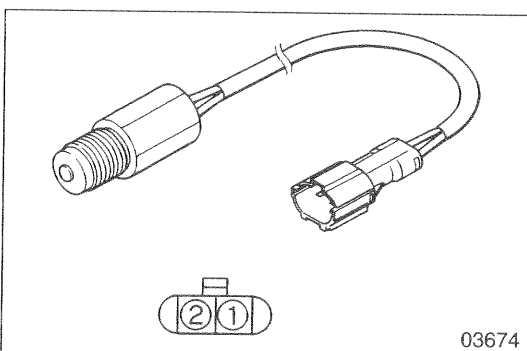
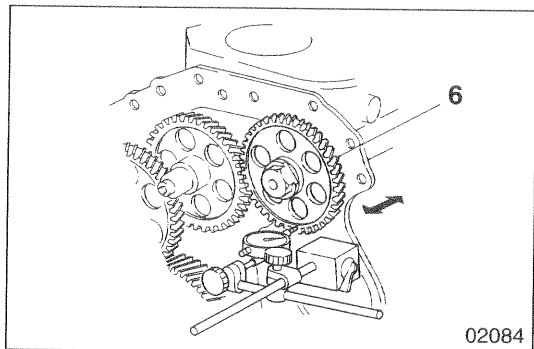

### ◆ Service procedure

#### ● Pre-disassembly inspection

##### Camshaft end play

If the end play measurement exceeds the specified limit, replace the defective part(s).

#### 1 Inspecting engine speed sensor

<Models with electric speed sensor>

- Measure the electrical resistance between terminals ① and ②.
- If the measurement is out of specification, replace the speed sensor 1.

Gr 11

#### CAUTION ⚠

Check the tightening torque of the engine speed sensor 1. If the sensor is insufficiently tightened, it may not produce signals.

&lt;6D14, 6D14-T, 6D15-T&gt;

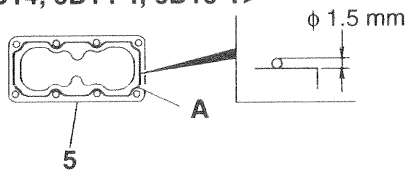

&lt;6D16, 16-E, 6D16-T, 16-TE, 6D16-TL, 16-TLE&gt;

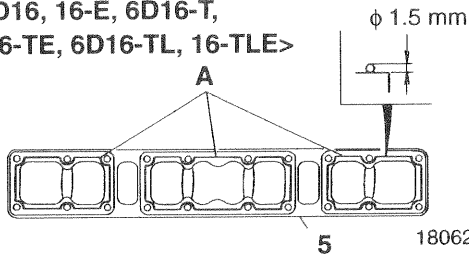

18062

**5 Fitting side cover**

- Apply an even, unbroken bead of sealant **A** to the side cover **5**.
- Fit the side cover **5** onto the crankcase within **3 minutes** of applying the sealant **A**.

**CAUTION** ⚠

- Ensure that the sealant application surface of the side cover **5** is clean before applying sealant.
- When fitting the side cover **5**, hold it firmly in position to prevent spreading the sealant.
- After fitting the side cover **5**, wait at least an hour before starting the engine.
- Apply a new bead of sealant **A** whenever the mounting bolts of the side cover **5** have been loosened.

**6 Camshaft assembly**

[Removal]

- When removing the camshaft assembly **6**, take off the side cover **5** and support the camshaft by hand.
- Remove the bolts **A** from the camshaft gear holes, then slowly remove the camshaft assembly **6**.

**CAUTION** ⚠

Take care not to damage the camshaft bushings **12** to **15** when removing the camshaft assembly **6**.

[Installation]

- Before installing the camshaft assembly **6**, measure the end play between the thrust plate **9** and camshaft **11**.
- If the measurement exceeds the specified limit, replace the defective part(s).
- With the alignment marks lined up on the camshaft gear **8** and No. 2 idler gear, fit the camshaft assembly. 📖 P.11-54

**8 Camshaft gear**

[Removal]

**CAUTION** ⚠

The camshaft gear **8** must be removed with the appropriate special tools. Do not tap off the camshaft gear since this would damage it.

☒a: Gear Puller

☒b: Plug

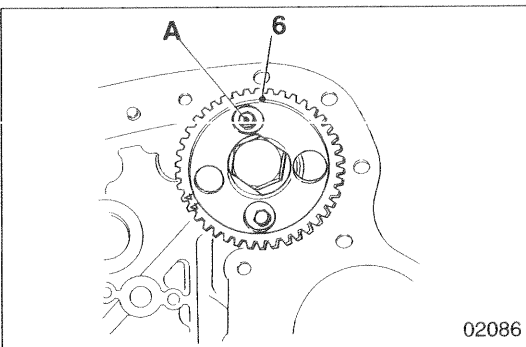

02086

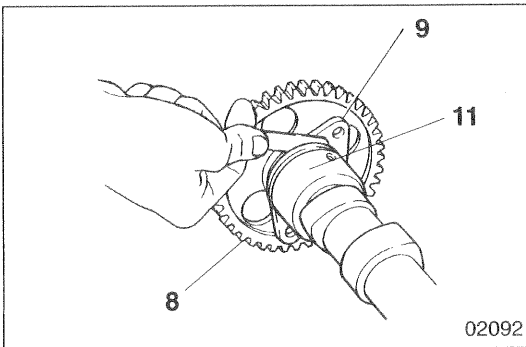

02092

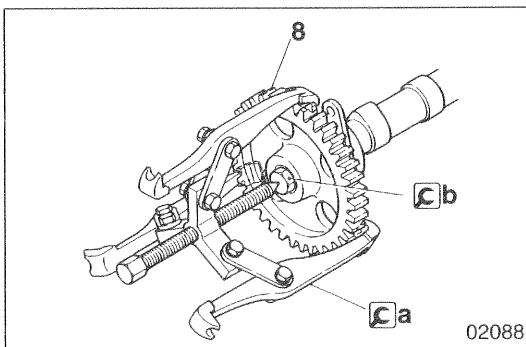

02088

# CAMSHAFT

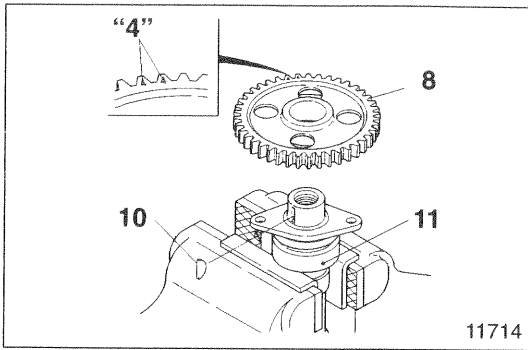

[Installation]

- Fit the camshaft gear 8 onto the camshaft 11 in the direction illustrated.
- Do not forget to fit the key 10.

## 11 Inspecting camshaft

### (1) Cam lift

If any base circle-to-lobe height difference is less than the required value, replace the camshaft 11.

#### NOTE

Since the cams are tapered, they must be measured at the position A shown in the diagram.

- B: Lobe height
- C: Base circle diameter
- D: Front of engine

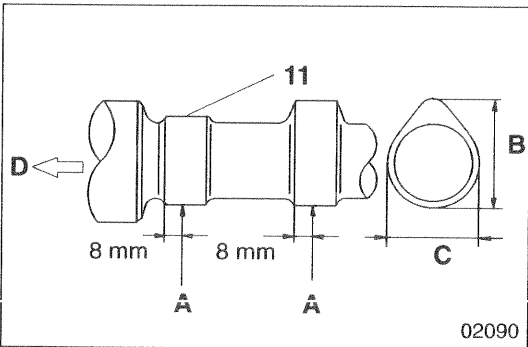

### (2) Camshaft bend

Support the camshaft 11 at its No. 1 journal E and No. 4 journal F, then take measurements at the No. 2 journal G and No. 3 journal H. If either measurement exceeds the specified limit, replace the camshaft.

#### NOTE

Turn the camshaft 11 through one revolution. One-half of the dial indicator reading represents the camshaft's bend.

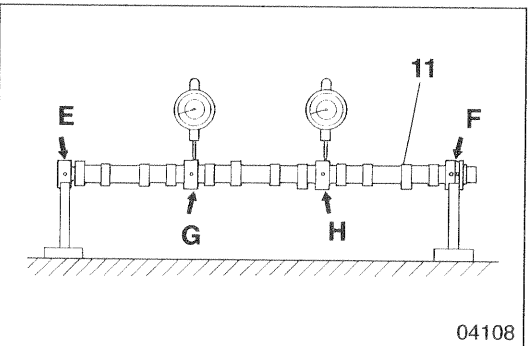

## 11 to 15 Camshaft and camshaft bushings

[Inspection]

If any clearance exceeds the specified limit, replace the defective part(s).

#### NOTE

Measure the camshaft bushings 12 to 15 with the camshaft installed in the crankcase\*.

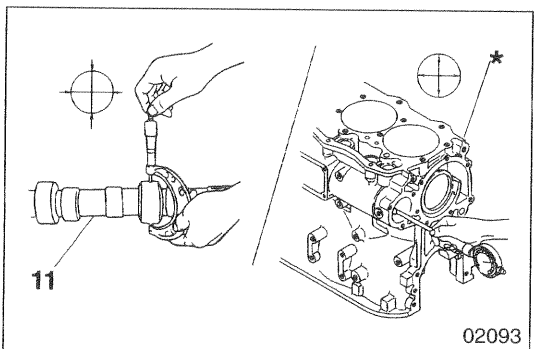

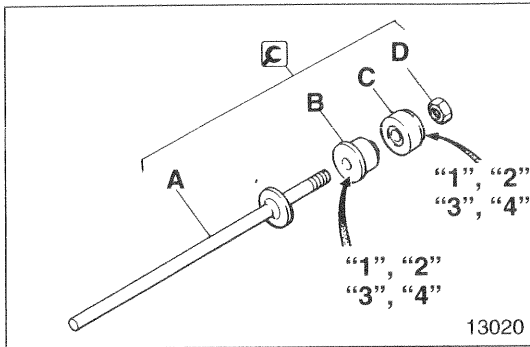

### Camshaft bushings

Removal and installation of camshaft bushings should be carried out using the  Camshaft Bushing Installer and Extractor. Each guide of the tool is stamped with an identification mark ("1", "2", "3", "4") in the position shown. Use correct adapter and/or guide piece to remove and install a bushing according to the table below.

Bushing No. (from front of engine)	Identification mark
No.1	1
No.2	2
No.3	3
No.4	4

<Components of  Camshaft Bushing Installer and Extractor>

- A : Rod
- B : Camshaft bushing adapter
- C : Guide piece
- D : Nut

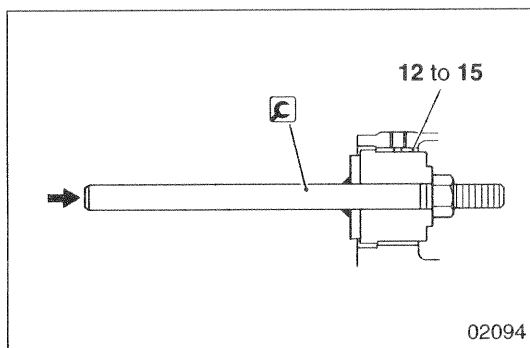

[Removal]

Remove the No. 4 and No. 3 camshaft bushings **12**, **13** from the rear of the engine. Remove the No. 2 and No. 1 camshaft bushings **14**, **15** from the front of the engine.

 : Camshaft Bushing Installer and Extractor

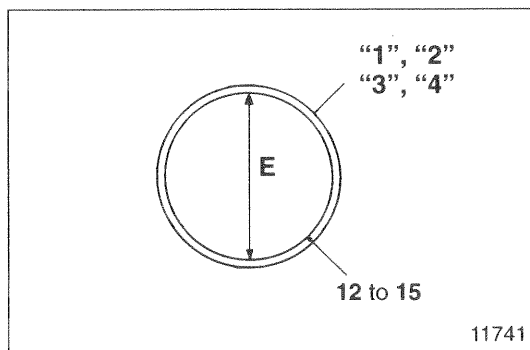



[Installation]

- Identify the No. 1 to No. 4 camshaft bushings **12** to **15** from their identification marks ("1", "2", "3", "4") in accordance with the table below. If any bushing's identification mark is unclear, identify the bushing from its internal diameter **E**.

Bushing No. (from front of engine)	Identification mark	Internal diameter (mm)
No.1	1	φ 57.75
No.2	2	φ 58.00
No.3	3	φ 58.25
No.4	4	φ 58.50

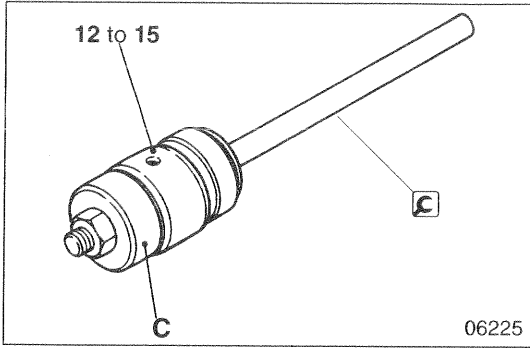
# CAMSHAFT



- Install the bushings 12 to 15 by using all components of the  Camshaft Bushing Installer and Extractor (rod A, camshaft bushing adapter B, guide piece C and nut D).
- Install the camshaft bushings 12 to 15 in the following order: No. 3, No. 4, No. 2 and No. 1.

## NOTE

Install the No. 3 and No. 4 camshaft bushings 12, 13 from the rear of the engine. Install the No. 1 and No. 2 camshaft bushings 14, 15 from the front of the engine.

- Ensure that the oil holes F in the No. 1 and No. 4 camshaft bushings 15, 12 are aligned with the oil holes G in the crankcase. With the No. 4 camshaft bushing, ensure also that the longer oil hole H is toward the rear of the engine.

J: Bushing clinch joint

: Camshaft Bushing Installer and Extractor

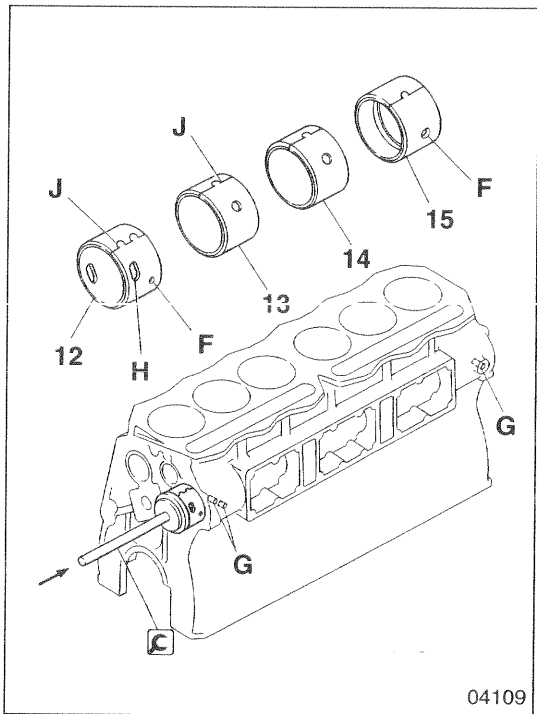

---

**MEMO**

---

# CRANKSHAFT AND CRANKCASE

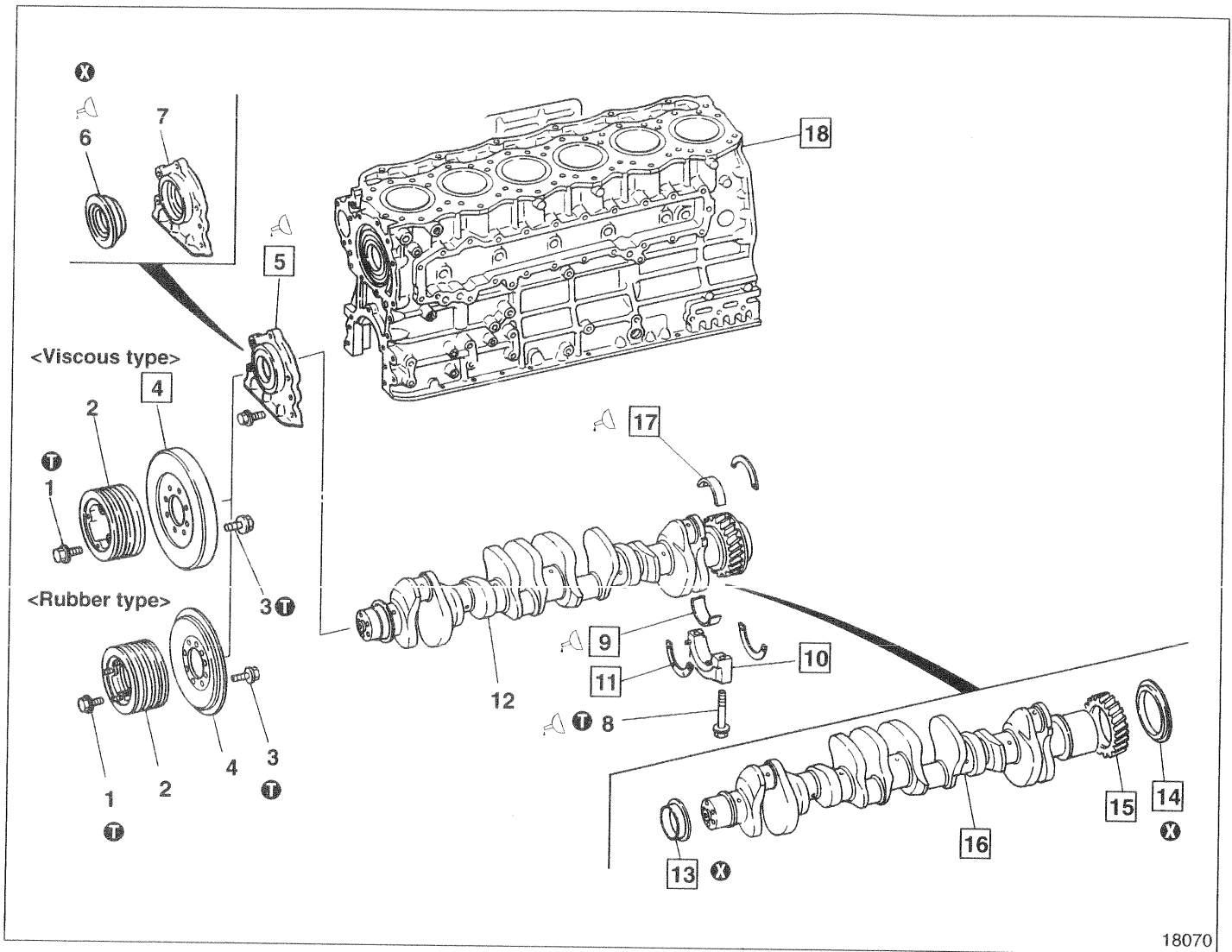

18070

## ● Pre-disassembly inspection

📖 P.11-75

## ● Disassembly sequence

- |                        |                               |                       |
|------------------------|-------------------------------|-----------------------|
| 1 Bolt                 | 10 Main bearing cap           | 16 Crankshaft         |
| 2 Crankshaft pulley    | 11 Thrust plate               | 17 Upper main bearing |
| 3 Bolt                 | 12 Crankshaft assembly        | 18 Crankcase          |
| 4 Torsional damper     | 13 Front oil seal slinger     |                       |
| 5 Front cover assembly | 14 Rear oil seal slinger      |                       |
| 6 Front oil seal       | <models without flywheel PTO> |                       |
| 7 Front cover          | Sleeve                        |                       |
| 8 Bolt                 | <models with flywheel PTO>    |                       |
| 9 Lower main bearing   | 15 Crankshaft gear            |                       |

ⓧ: Non-reusable part

## NOTE

Do not remove front oil seal slinger 13, rear oil seal slinger (or sleeve) 14 and crankshaft 15 unless faulty.

## ● Assembly sequence

Reverse the order of disassembly.

## Service standards

Unit: mm

Location	Maintenance item		Standard value (Basic diameter in [ ])	Limit	Remedy	
9, 17	Main bearing	Oil clearance	Except 6D15-T (with dry cylinder liners)	[84] 0.05 to 0.10	0.15	Replace
			6D15-T (with dry cylinder liners)	[80] 0.05 to 0.10		
		Span when free		—	Less than 85.5	Replace
16	Crankshaft	End play		0.10 to 0.25	0.4	Replace
		Bend		0.05 or less	0.1	Correct or replace
		Pin and journal	Roundness	0.01 or less	0.03	Correct or replace
			Cylindricity	0.006 or less	—	Correct or replace
18	Distortion of crankcase top surface		0.07 or less	0.2	Replace	

## ① Tightening torques

Unit: N·m {kgf·m}

Location	Parts to be tightened	Tightening torque	Remarks
1	Crankshaft pulley mounting bolt	185 {19}	—
3	Torsional damper mounting bolt	67 {8}	—
8	Main bearing cap mounting bolt	67 {8} + 90°	<ul style="list-style-type: none"> <li>● Wet</li> <li>● Can be reused up to 3 times</li> </ul>  P.11-76

 Lubricant and/or sealant

Location	Points of application	Specified lubricant and/or sealant	Quantity
5	Crankcase mounting surface of front cover assembly	Threebond 1207C	As required
6	Front oil seal lip	Engine oil	As required
8	Bolt threads	Engine oil	As required
9, 17	Main bearing inside surfaces	Engine oil	As required
14	Apply inner surface of sleeve <with flywheel PTO>	Engine oil	As required

# CRANKSHAFT AND CRANKCASE

## Special tools

Unit: mm

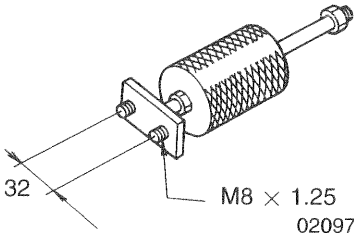
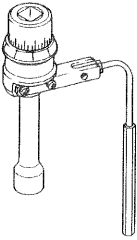
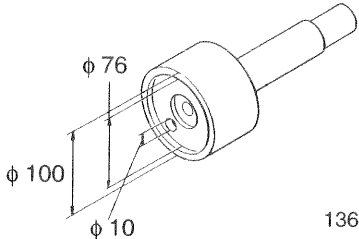
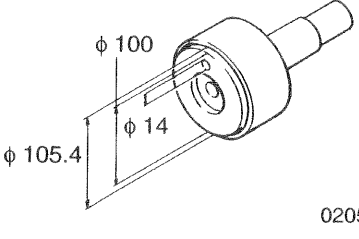
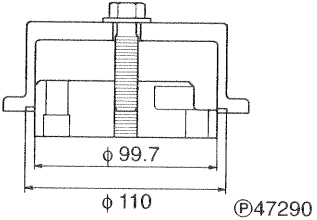
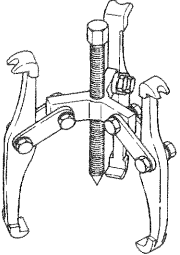
Location	Tool name and shape	Part No.	Application
10	Main Bearing Cap Extractor  32 M8 × 1.25 02097	MH061189	Removing main bearing caps
	Socket Wrench  01984	MH061560	Fitting main bearing caps
13	Front Oil Seal Slinger Installer  φ 76 φ 100 φ 10 13625	MH062710	Installing front oil seal
14	Rear Oil Seal Slinger Installer  φ 100 φ 14 φ 105.4 02051	MH061470	Installing rear oil seal slinger <without flywheel PTO>
	Sleeve Installer  φ 99.7 φ 110 ©47290	MH062037	Installing rear oil seal sleeve <with flywheel PTO>
15	Gear Puller  02065	MH061326	Removing crankshaft gear

## ◆ Service procedure

### ● Pre-disassembly inspection

#### Crankshaft assembly end play

If the measurement exceeds the specified limit, replace the defective part(s).

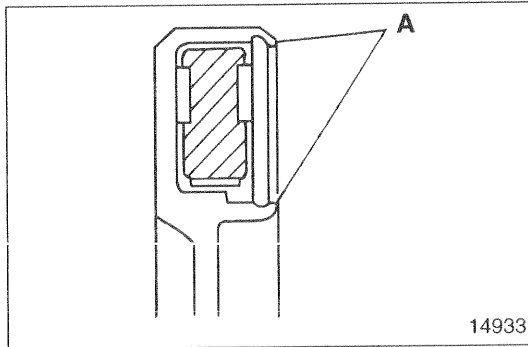
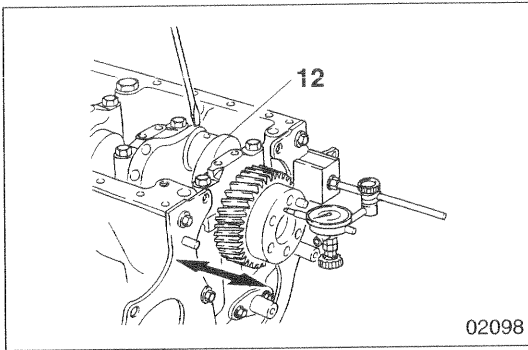

#### 4 Torsional damper <Viscous type>

#### CAUTION ⚠

Leakage of silicon oil from the caulked seam A can cause the viscous-type torsional damper to stop functioning. Note the following points:

- Check that the caulked seam is free of gouges and other damage.
- Do not submit the torsional damper to shock by striking it with a hammer or dropping it.
- Do not roll the torsional damper or stack it with other units.

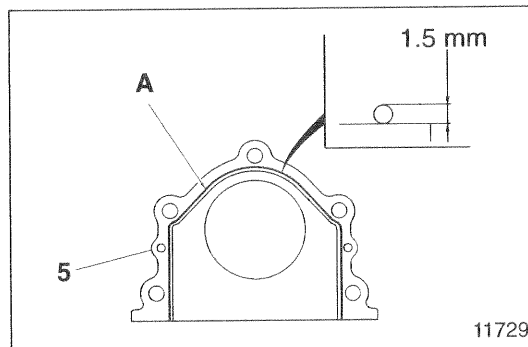

#### 5 Installing front cover assembly

- Apply an even, unbroken bead of sealant A to the mating surface of the front cover assembly 5 to be mounted to the crankcase 20.
- Fit the front cover assembly 5 onto the crankcase 20 within 3 minutes of applying the sealant A.

#### CAUTION ⚠

- Ensure that the sealant application surface of the front cover assembly 5 is clean before applying sealant.
- When fitting the front cover assembly 5, hold it firmly in position to prevent spreading the sealant.
- After fitting the front cover assembly 5, wait at least an hour before starting the engine.
- Apply a new bead of sealant A whenever the mounting bolt of the front cover assembly 5 have been loosened.

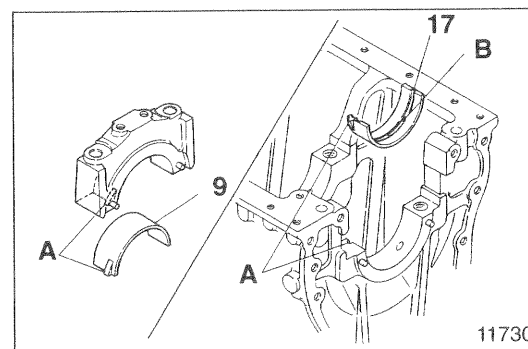

#### 9 17 Main bearings

[Installation]

Install the main bearings 9, 17 such that their lugs A fit into the corresponding grooves.

#### CAUTION ⚠

The upper main bearing 17 has an oil hole B. The lower main bearing 9 has no oil hole. Take care not to confuse the upper and lower parts.

# CRANKSHAFT AND CRANKCASE

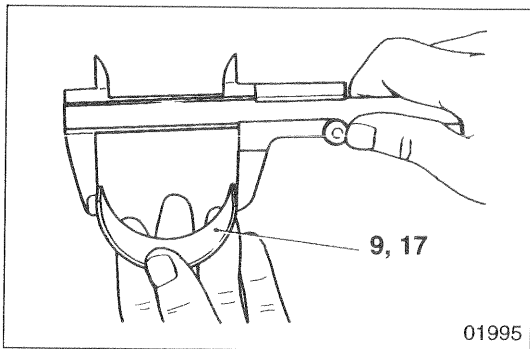

[Inspection]

## CAUTION

- Do not attempt to manually expand either bearing 9, 17 if its span is insufficient.
- Upper and lower bearings 9, 17 must be replaced as a set.

### (1) Span when free

If either bearing's span when free exceeds the specified limit, the bearings 9, 17 must be replaced.

### (2) Main bearing-to-crankshaft clearance

- Fit the upper main bearing 17 into the crankcase 18 and the lower main bearing 9 into the main bearing cap 10. Then, tighten the bolts 8 to their specified torque.
- Measure the internal diameters of the main bearings 9, 17 and the outside diameter A of the crankshaft journal. If the clearance exceeds the specified limit, replace the defective part(s).

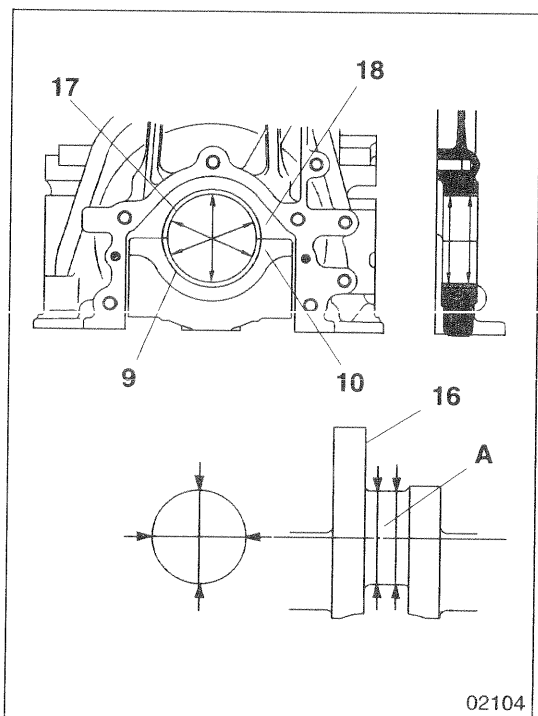

## **10** Main bearing caps

[Removal]

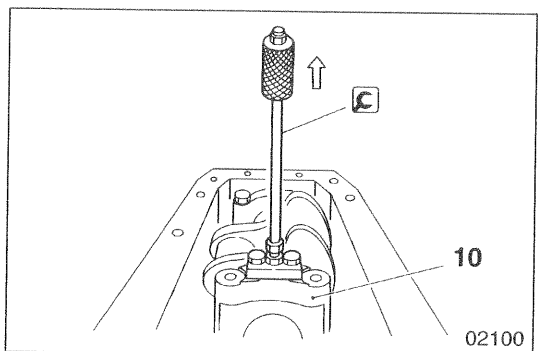

[Installation]

- Starting at the front of the engine B, fit the main bearing caps 10 in the order of the numbers A embossed on them and such that the numbers are in the positions illustrated.
- The bolts 8 can be reused only three times. Before fitting the bolts, make a punch mark on the head of each bolt to indicate times of reuse.

## CAUTION

If any bolt already has three punch marks, it must not be reused any more; replace it with a new one.

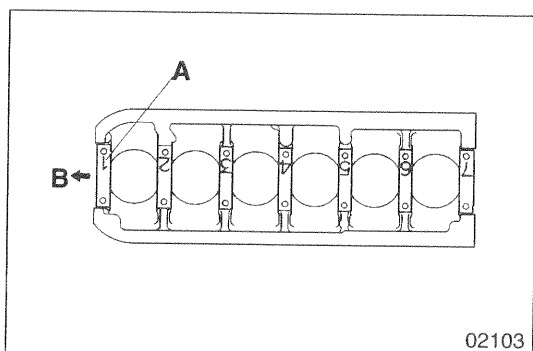

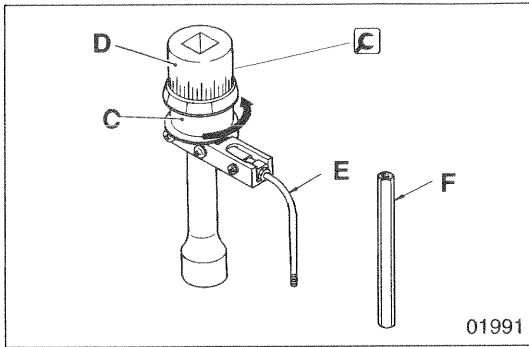

- Tighten the bolts **8** to the specified torque. Then, turn the bolts further in accordance with the following procedure:
- Turn the holder **C** of the  Socket Wrench counter-clockwise to tension the built-in spring.

**D:** Socket  
**E:** Rod  
**F:** Rod (extension)

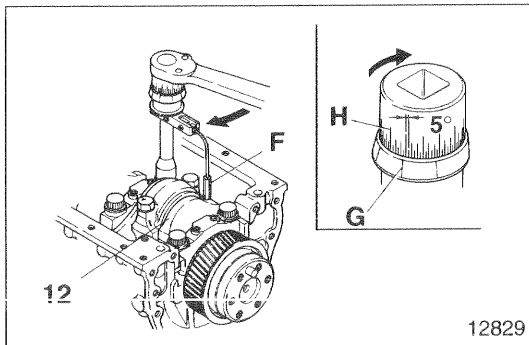

- Set the socket wrench such that the built-in spring force forces the rod **F** against the crankshaft assembly **12**.
- On the holder **C**, select the inscribed line **G** that is easiest to see.
- Using the selected line as a reference, turn the socket **D** 90° clockwise. (One gradation on the scale **H** represents 5°.)

### CAUTION

Since the bolts utilize the plastic region tightening method, they must not be tightened further after this procedure.

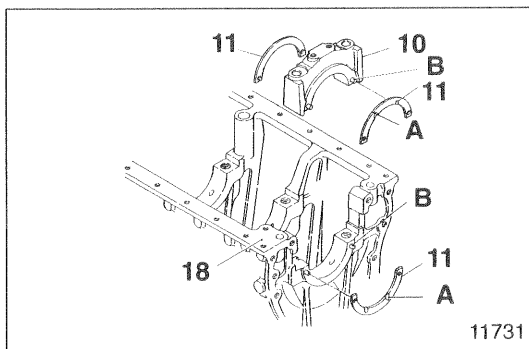

### 11 Installing thrust plates

Fit a thrust plate **11** on each side of the main bearing caps **10** and at the rear end of the crankcase **18** such that the oil grooves **A** are on the outside.

**B:** Locating pin

### NOTE

If oversize thrust plates **11** are used, they must be fitted on both sides of the bearing caps **10**. Ensure that the bearing cap rear thrust plates and the rearmost thrust plate in the crankcase **18** are the same size. Note, however, that the front and rear thrust plates on each bearing cap may be of different sizes.

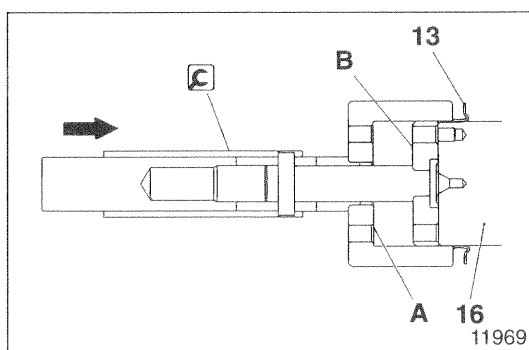

### 13 Installing front oil seal slinger

Using the  Front Oil Seal Slinger Installer, drive the front oil seal slinger **13** onto the crankshaft **16** until the tool's end face **A** is pressed firmly against the guide **B**.

# CRANKSHAFT AND CRANKCASE

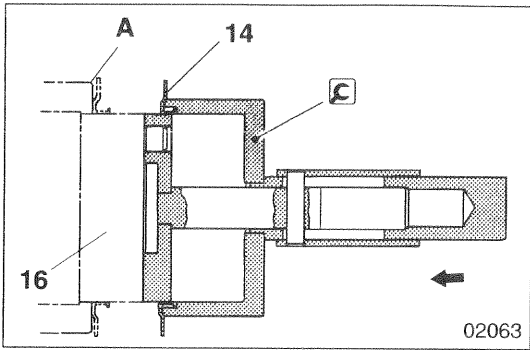

## 14 Rear oil seal slinger and sleeve

[Installation]

<Models without flywheel PTO>

Using the (C) Rear Oil Seal Slinger Installer, drive the rear oil seal slinger 14 onto the crankshaft 16 until it is pressed firmly against the end face A of the crankshaft gear 15.

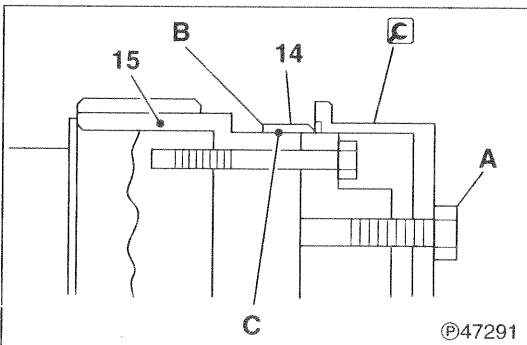

<Models with flywheel PTO>

If the outer surface of the sleeve 14 is scratched or grooved, replace the sleeve as follows.

[Removal]

Use a chisel to cut the sleeve 14, then remove the sleeve from the crankshaft gear 15.

**CAUTION** ⚠

Be careful not to damage the crankshaft gear 15.

[Installation]

With the sleeve 14 set as shown (pay attention to the direction), turn the bolt A of the (C) Sleeve Installer as far as it goes. Do not tighten the bolt firmly.

B: White paint

C: Apply engine oil

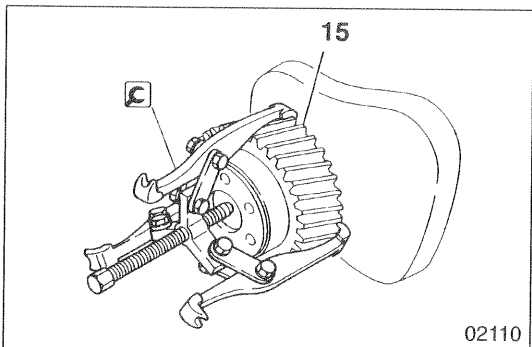

## 15 Crankshaft gear

<Models without flywheel PTO>

[Removal]

**CAUTION** ⚠

Do not tap off the crankshaft gear 15 since this could damage it.

(C): Gear Puller

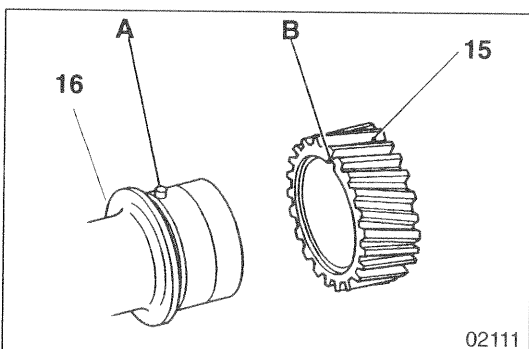

[Installation]

- Using a piston heater or the like, heat the crankshaft gear 15 to a temperature of approximately 100°C.
- Align the locating pin A on the crankshaft 16 with the notch B in the crankshaft gear 15. Then, drive the gear into position by striking its end face with a plastic mallet.

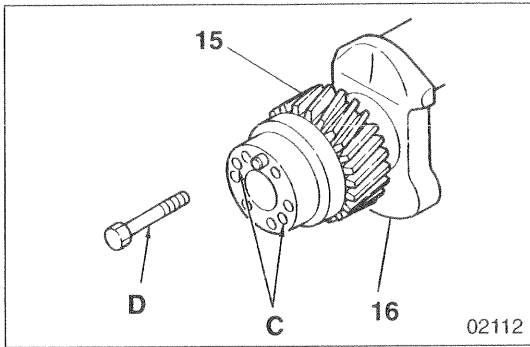

<Models with flywheel PTO>

[Removal]

Screw the flywheel mounting bolts **D** evenly into the threaded removal holes **C** in the crankshaft **16**. Alternatively, remove the crankshaft gear using the  Gear Puller.

**CAUTION** 

Do not tap off the crankshaft gear since this could damage it.

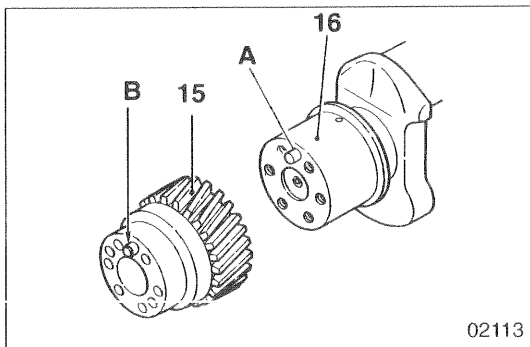

[Installation]

- Using a piston heater or the like, heat the crankshaft gear **15** to a temperature of approximately 100°C.
- Align the locating pin **A** on the crankshaft **16** with the dowel pin **B** on the crankshaft gear **15**. Then, drive the gear into position by striking its end face with a plastic mallet.

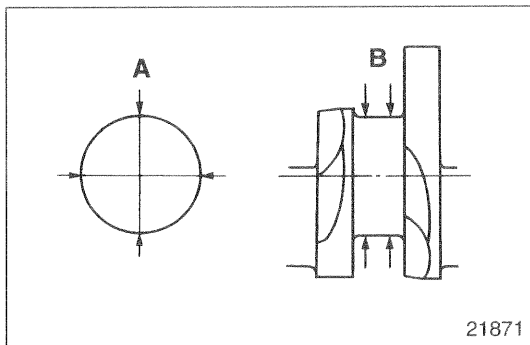

## 16 Crankshaft

[Inspection]

### (1) Roundness and cylindricity of crankshaft journal and pin

If either measurement exceeds the specified limit, replace the crankshaft **16** or grind it to undersize.

**A**: Roundness

**B**: Cylindricity

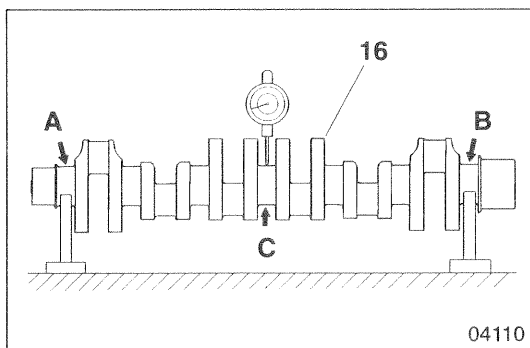

### (2) Bend

- Support the crankshaft **16** at its No. 1 journal **A** and No. 7 journal **B**. Measure the extent of bending in the crankshaft at the centre of the No. 4 journal **C**.
- If the measurement exceeds the specified limit, replace the crankshaft.

### NOTE

With the dial indicator applied to the centre journal, turn the crankshaft **16** through one revolution. One-half of the dial indicator reading represents the extent of bending.

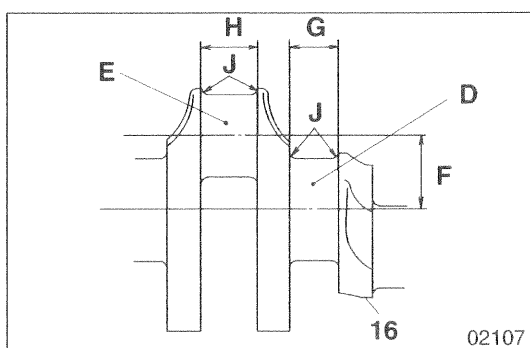

[Rectification]

### NOTE

If the crankshaft **16** is rectified by grinding, the main bearings **9**, **17** must be replaced with undersized ones.

- Grind such that the centre-to-centre distance **F** between the journal **D** and pin **E** does not change.

**F**: 57.5  $\begin{matrix} +0.025 \\ -0.075 \end{matrix}$  mm

# CRANKSHAFT AND CRANKCASE

- Grind such that the journal width **G** and pin width **H** do not change.  
**G**: 37 mm  
**H**:  $42 \begin{smallmatrix} +0.2 \\ 0 \end{smallmatrix}$  mm
- Finish the corner fillet smoothly and to the specified radius **J**.  
**J**:  $R4 \pm 0.2$  mm
- Carry out a magnetic inspection to check for cracks caused by grinding. Also, check that the Shore hardness of the surface has not dropped below Hs 75.

Crankshaft undersize dimensions

Unit: mm

		Degree of undersize			
		0.25	0.50	0.75	1.00
Finished journal diameter	Except 6D15-T (with dry cylinder liners)	83.685 to 83.705	83.435 to 83.455	83.185 to 83.205	82.935 to 82.955
	6D15-T (with dry cylinder liners)	79.685 to 79.705	79.435 to 79.455	79.185 to 79.205	78.935 to 78.955
Finished pin diameter	Except 6D16-TLE	64.67 to 64.69	64.42 to 64.44	64.17 to 64.19	63.92 to 63.94
	6D16-TLE	69.67 to 69.69	69.42 to 69.44	69.17 to 69.19	68.92 to 68.94
Roundness		0.01 or less			
Cylindricity		0.006 or less			

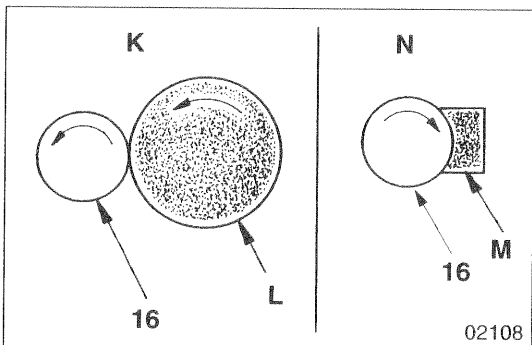

- When grinding **K**, turn the crankshaft **16** counter-clockwise as viewed from its front end. The grinder **L** should rotate in the same direction.
- When finishing **N** the crankshaft **16** with sandpaper or a whetstone **M**, rotate the crankshaft clockwise.

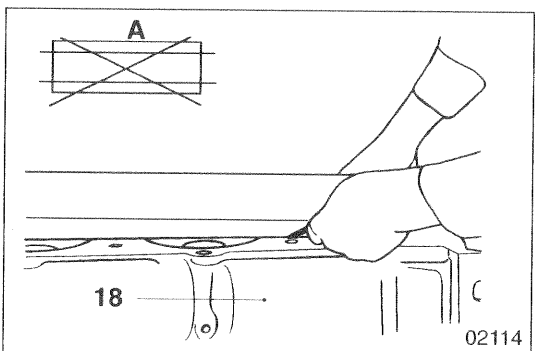

## 18 Distortion of crankcase top surface

If distortion exceeds the specified limit, correct it with a surface grinder.

**A**: Measurement positions

## CAUTION

When grinding the crankcase **18**, take care that the piston projections stay within specification.

# GROUP 12 LUBRICATION

SPECIFICATIONS .....	12-2
<b>STRUCTURE AND OPERATION</b>	
1. Lubrication System .....	12-3
2. Oil Pump .....	12-4
3. Oil Filter .....	12-4
4. Oil Cooler .....	12-6
5. Engine Oil Pressure Switch, Regulator Valve .....	12-7
6. Lubrication of Related Parts .....	12-7
TROUBLESHOOTING .....	12-12
<b>ON-VEHICLE INSPECTION AND ADJUSTMENT</b>	
1. Oil Filter Replacement .....	12-13
2. Engine Oil Replacement .....	12-17
3. Oil Pressure Measurement .....	12-18
OIL PAN, OIL JET, AND OIL LEVEL SENSOR .....	12-20
OIL PUMP AND OIL STRAINER .....	12-22
<b>OIL FILTER</b>	
<Spin-on Type> .....	12-26
<Replaceable-element Type> .....	12-28
<b>OIL COOLER</b>	
<Except 6D16-TLE> .....	12-30
<6D16-TLE> .....	12-32
REGULATOR VALVE .....	12-34

# SPECIFICATIONS

Item			Specifications
Mode of lubrication			Oil pump type
Oil filter type			Spin-on paper-filter type or replaceable-element type
Oil cooler type			Shell and plate type (multi-plate type)
Engine oil			Turbocharged engine: API CD or above
			Non-turbocharged engine: API CC or above
Oil quantity dm <sup>3</sup> {L}	Oil pan	General power applications	Approx. 9.5 {9.5}
		Construction machinery applications	Approx. 16 {16}
	Oil filter	Spin-on type: A, B type	2.1 {2.1}
		Spin-on type: C type, Replaceable-element type	2.3 {2.3}

## 1. Lubrication System (Oil Flow)

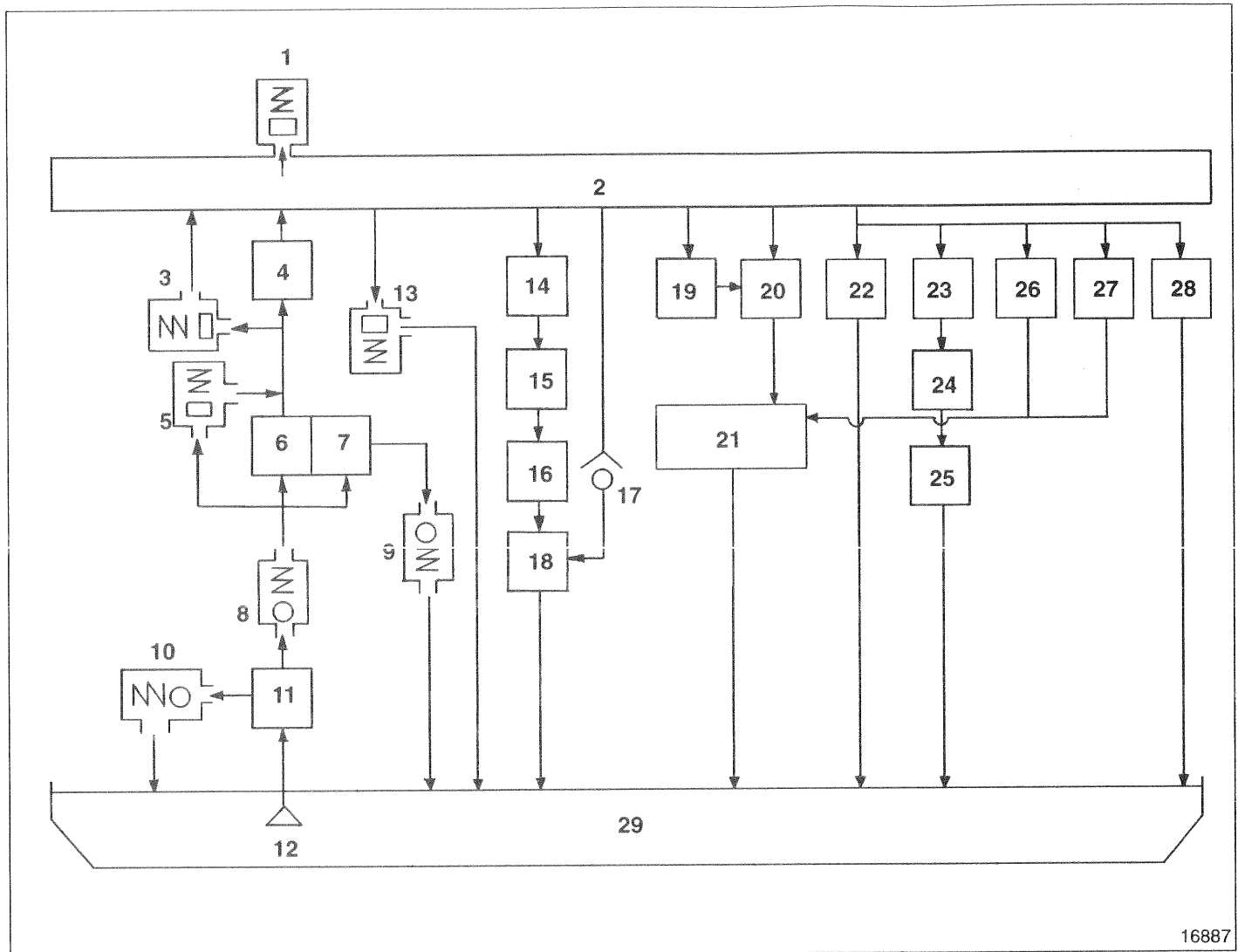

16887

- |  |   |
|--|---|
| 1 Engine oil pressure gauge unit             | 16 Connecting rod bushing                           |
| 2 Main oil gallery                           | 17 Check valve for oil jet                          |
| 3 Bypass valve                               | 18 Piston   |
| 4 Oil cooler                                 | 19 Injection pump                                   |
| 5 Engine oil bypass alarm switch             | 20 Injection pump drive (or air compressor)         |
| 6 Full-flow filter element                   | 21 Timing gears                                     |
| 7 Bypass filter element                      | 22 Camshaft bushing                                 |
| 8 Check valve (built into oil filter)        | 23 Rocker bushing                                   |
| 9 Bypass check valve (built into oil filter) | 24 Push rod   |
| 10 Relief valve (built into oil pump)        | 25 Tappet   |
| 11 Oil pump                                  | 26 Idler gear shaft No. 1                           |
| 12 Oil strainer                              | 27 Idler gear shaft No. 2                           |
| 13 Regulator valve                           | 28 Turbocharger <6D14-T, 15-T, 16-T, 16-TL, 16-TLE> |
| 14 Crankshaft main bearing                   | 29 Oil pan  |
| 15 Connecting rod bearing                    |   |

# STRUCTURE AND OPERATION

## 2. Oil Pump

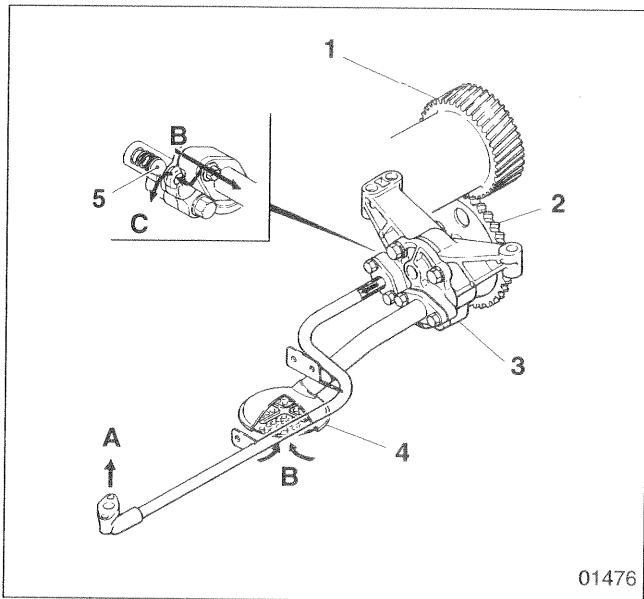

- 1 Crankshaft gear
- 2 Oil pump gear
- 3 Oil pump
- 4 Oil strainer
- 5 Relief valve

- A: To oil filter  
B: From oil pan  
C: To oil pan

Oil pump 3 is a gear type. It is driven by rotation of the crankshaft via crankshaft gear 1 and oil pump gear 2.

Relief valve 5 is fitted to the oil pump. When the oil pump discharge pressure exceeds a specified level, the relief valve returns some of the engine oil to the oil pan, thus protecting the lubrication system from excessive oil pressure.

01476

## 3. Oil Filter

<Spin-on type (A, B type)>

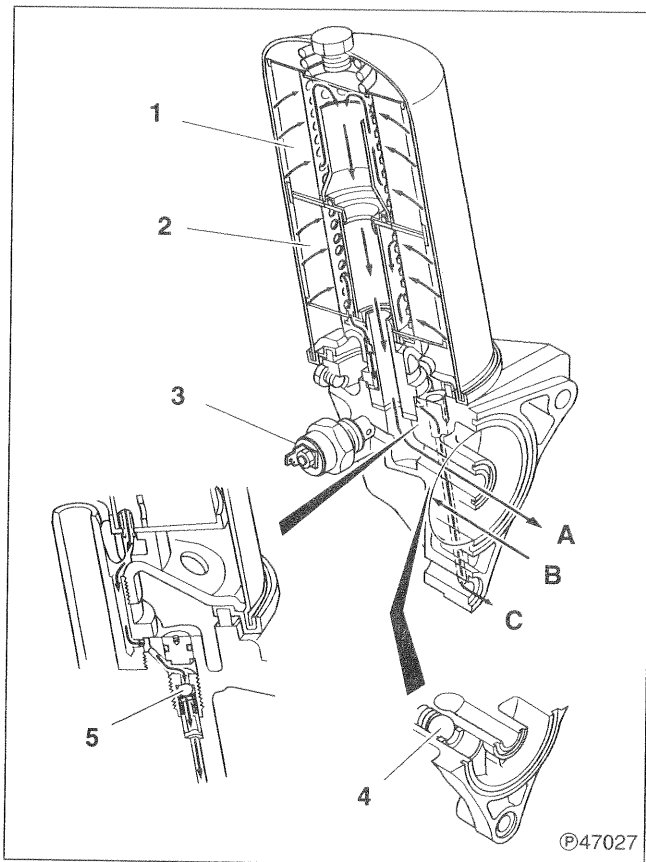

- 1 Full-flow filter element
- 2 Bypass filter element
- 3 Engine oil bypass alarm switch
- 4 Check valve
- 5 Bypass check valve

- A: To oil cooler  
B: From oil pump  
C: To oil pan

This oil filter is a spin-on paper-filter type incorporating full-flow filter element 1 and bypass filter element 2.

Engine oil bypass alarm switch 3 is fitted to the oil filter bracket. If clogging causes the pressure difference before and after the element to exceed a specified level, a valve inside the switch opens to allow oil to flow directly to the oil cooler.

Check valve 4 is fitted to the inlet to prevent a reverse flow of oil out of the filter when the engine is stationary. In conjunction with this, bypass check valve 5 opens only when oil pressure in the bypass arrangement exceeds a specified level. As a result, the oil level in the filter is kept constant and oil reaches all parts of the lubrication system quickly when the engine is started.

©47027

## &lt;Spin-on type (C type)&gt;

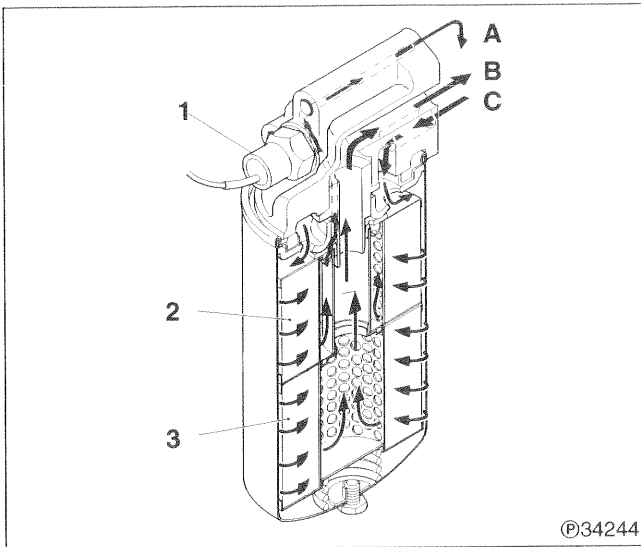

©34244

- 1 Engine oil bypass alarm switch
- 2 Bypass filter element
- 3 Full-flow filter element

A: To oil pan  
 B: To oil cooler  
 C: From oil pump

This oil filter is a paper-filter type incorporating full-flow filter element 3 and bypass filter element 2.

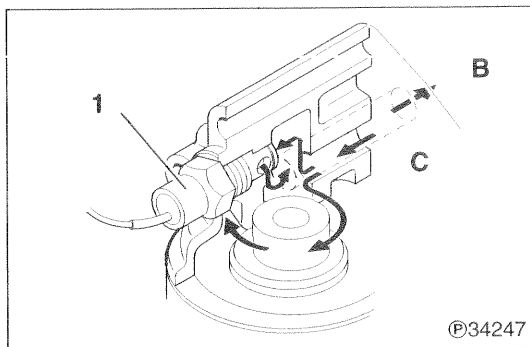

©34247

**Engine oil bypass alarm switch**

- If the oil filter element becomes clogged, the flow of engine oil is restricted, causing engine parts to seize. To prevent this, engine oil bypass alarm switch 1 is fitted to the spin-on filter.
- When the oil filter element becomes clogged, engine oil bypass alarm switch 1 is activated. As a result, engine oil is allowed to flow directly to the oil cooler, bypassing full-flow filter element 3. When the engine oil bypass alarm switch is activated, a warning lamp illuminates to notify the operator of the clogged oil filter element.

## &lt;Replaceable-element type&gt;

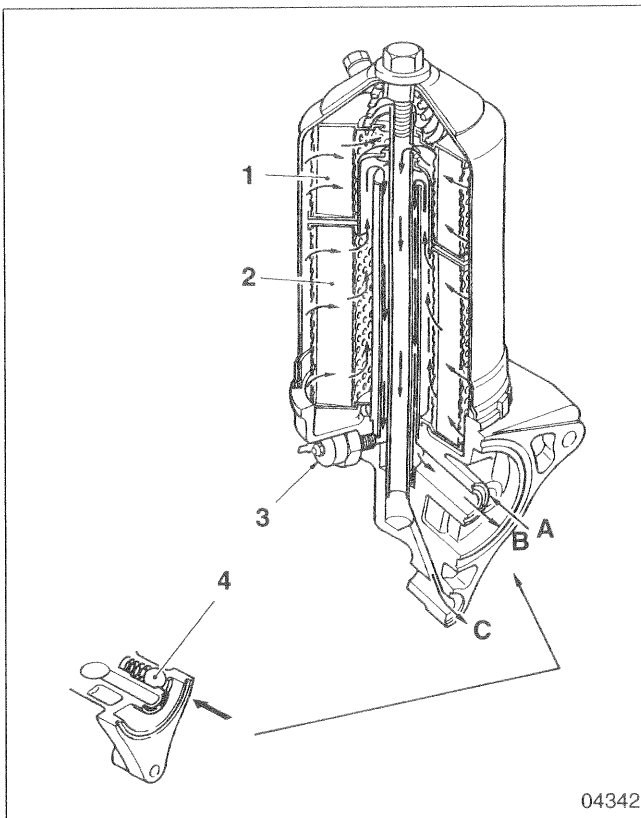

04342

- 1 Full-flow filter element
- 2 Bypass filter element
- 3 Engine oil bypass alarm switch
- 4 Check valve

A: From oil pump  
 B: To oil cooler  
 C: To oil pan

This oil filter is a replaceable-element type incorporating full-flow filter element 1 and bypass filter element 2.

Engine oil bypass alarm switch 3 is fitted to the oil filter bracket. If clogging causes the pressure difference before and after the element to exceed a specified level, a valve inside the switch opens to allow oil to flow directly to the oil cooler.

Check valve 4 is fitted to the inlet to prevent a reverse flow of oil out of the filter when the engine is stationary. This ensures that the oil level in the filter remains constant such that oil reaches all parts of the lubrication system quickly when the engine is started.

# STRUCTURE AND OPERATION

## 4. Oil Cooler

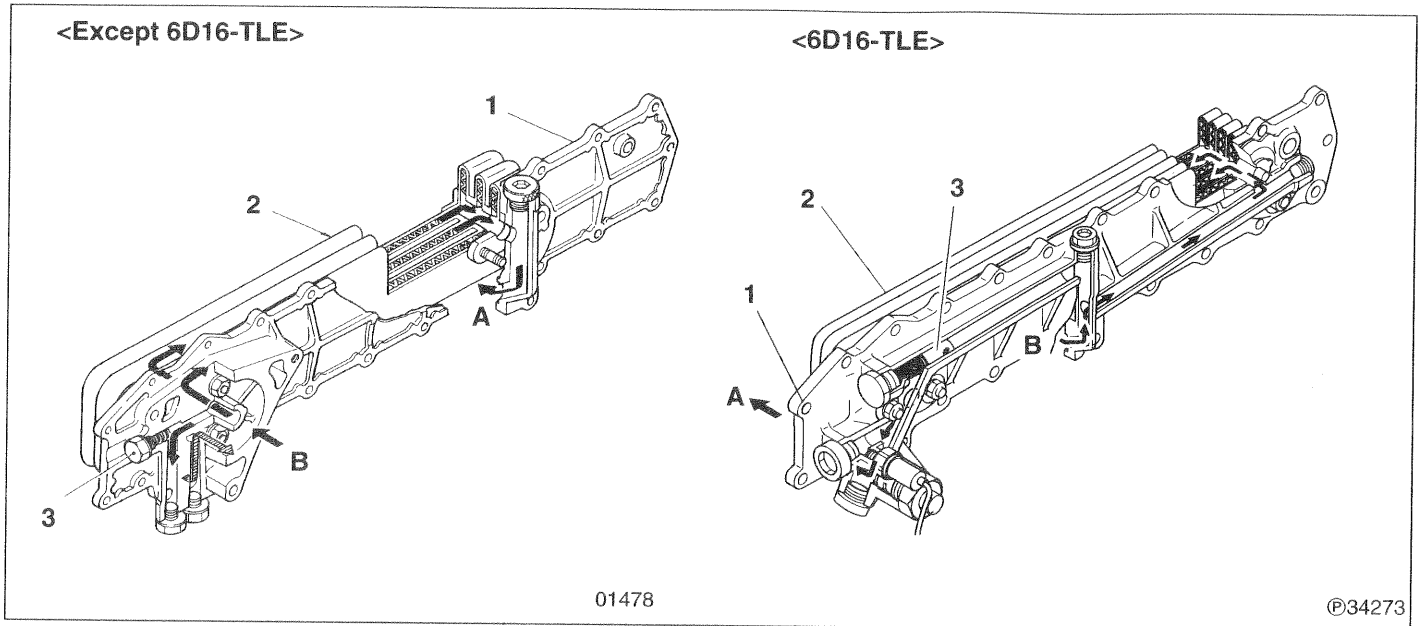

- 1 Oil cooler cover
- 2 Oil cooler element
- 3 Bypass valve

- A: To main oil gallery
- B: From oil filter

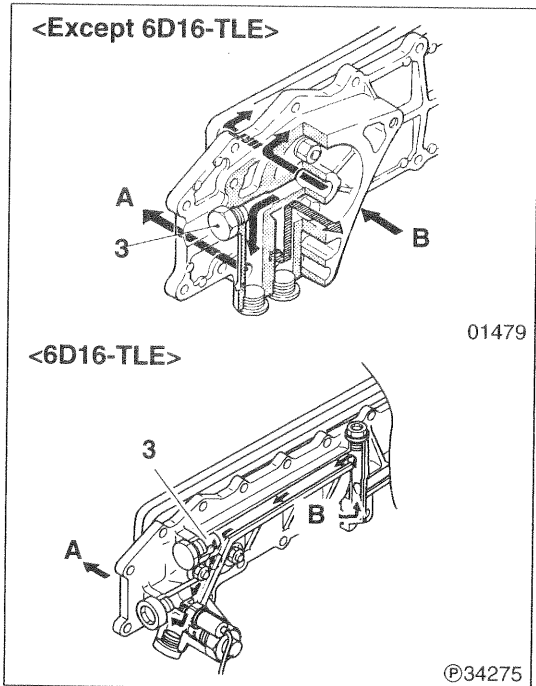

### ● Bypass valve

Bypass valve 3 is fitted to the oil cooler. When engine oil is cool and its viscosity is high, or when the oil cooler element becomes clogged and restricts the flow of engine oil, this valve opens. As a result, engine oil is allowed to flow directly to the main oil gallery, bypassing the oil cooler.

- A: To main oil gallery
- B: From oil filter

## 5. Engine Oil Pressure Switch, Regulator Valve

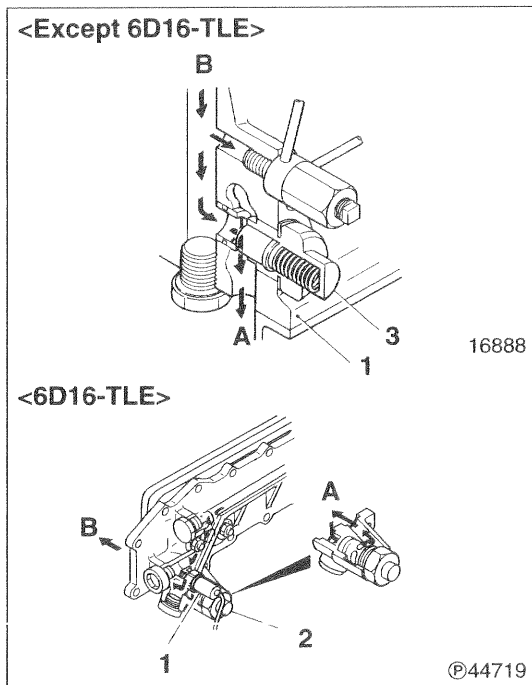

- 1 Crankcase
- 2 Engine oil pressure switch
- 3 Regulator valve

A: To oil pan  
B: Main oil gallery

### ● Engine oil pressure switch

If the pressure of engine oil to the main oil gallery drops below a specified level, an electrical contact incorporated in engine oil pressure switch 2 closes. This causes a relevant warning lamp on the meter cluster to illuminate, notifying the operator of the excessive pressure drop.

### ● Regulator valve

If the oil pressure in the main oil gallery exceeds a specified level, regulator valve 3 opens to allow some of the engine oil to return to the oil pan, thereby regulating the oil pressure to specification.

## 6. Lubrication of Related Parts

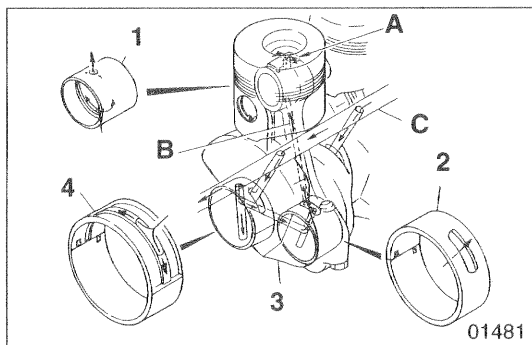

Engine oil fed to the main oil gallery lubricates the following related parts:

### ● Main Bearing and Connecting Rod Bearing

- 1 Connecting rod bushing
- 2 Connecting rod bearing
- 3 Crankshaft
- 4 Main bearing

A: Oil jet  
B: Connecting rod oil passage  
C: Main oil gallery

Oil supplied via the oil passage in crankshaft 3 flows through connecting rod oil passage B to lubricate the connecting rod's small end. The oil then sprays out of oil jet A at the top of the connecting rod to cool the piston.

# STRUCTURE AND OPERATION

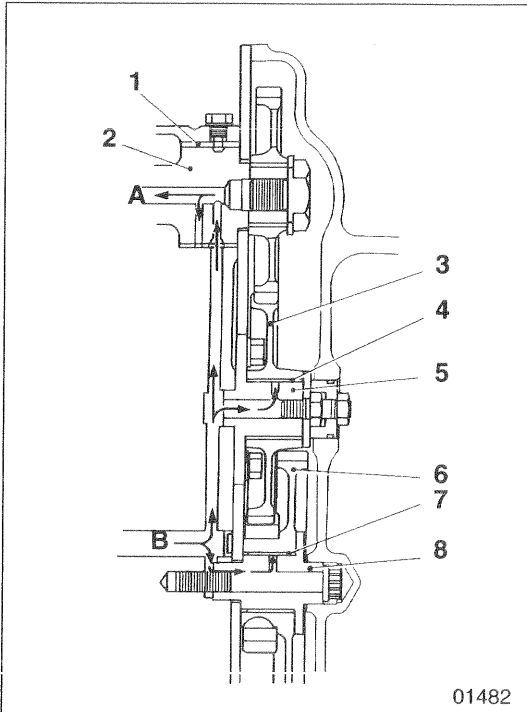

## ● Timing gear and camshaft

- 1 Camshaft bushing No. 4
- 2 Camshaft
- 3 Idler gear No. 2
- 4 Idler gear bushing
- 5 Idler shaft No. 2
- 6 Idler gear No. 1
- 7 Idler gear bushing
- 8 Idler gear shaft No. 1

A: To rocker bushing  
B: From main oil gallery

Engine oil flows through the inside of camshaft 2 and lubricates each camshaft bushing.

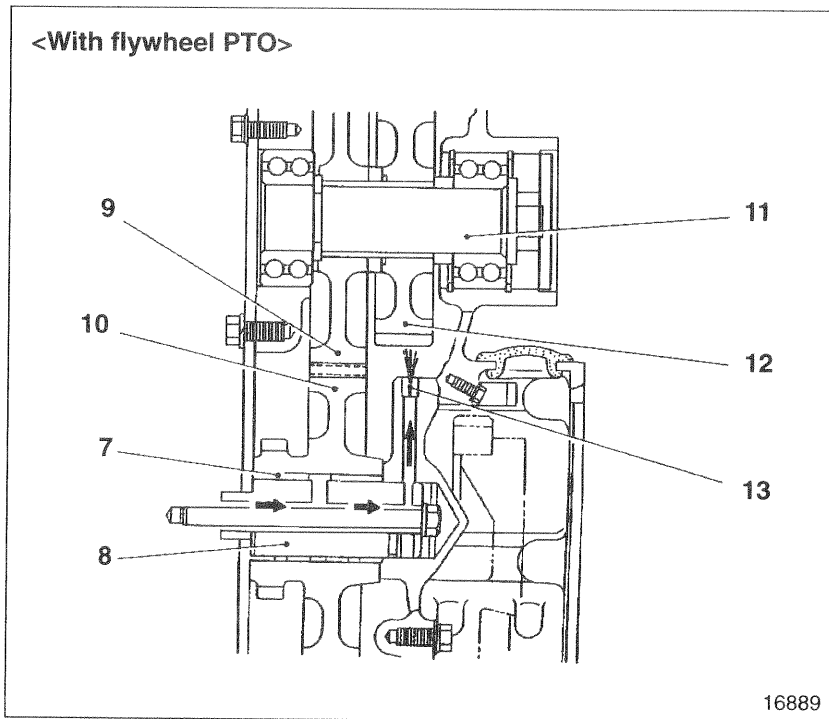

<With flywheel PTO>

If a flywheel power take-off (PTO) is fitted, oil flows through an oil passage in the flywheel housing and sprays out of the oil jet to lubricate PTO idler gear B 12.

- 9 PTO idler gear A
- 10 Idler No. 1
- 11 PTO idler shaft
- 12 PTO idler gear B
- 13 Oil jet

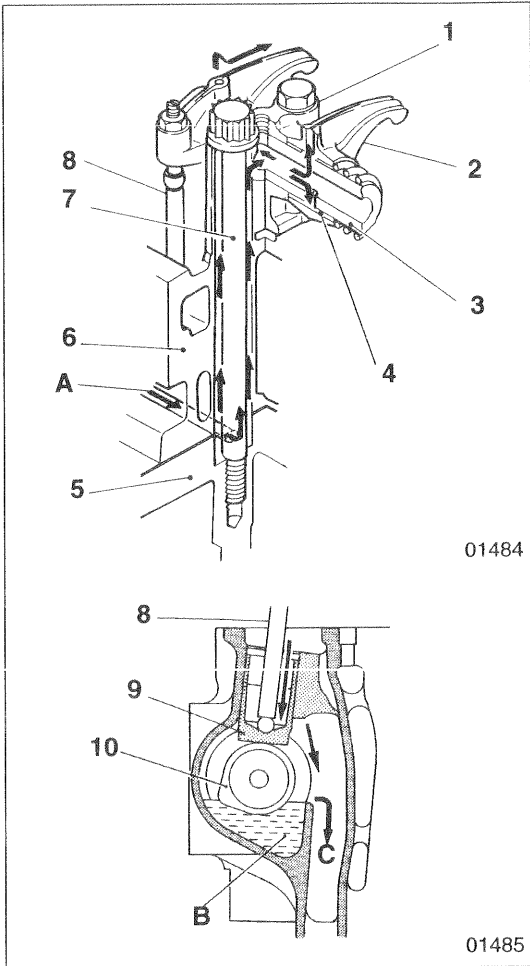

### ● Valve mechanism

- 1 Rocker shaft bracket
- 2 Rocker
- 3 Rocker shaft
- 4 Rocker bushing
- 5 Crankcase
- 6 Cylinder head
- 7 Cylinder head bolt
- 8 Push rod
- 9 Tappet
- 10 Camshaft

**A:** From camshaft bushing No. 4

**B:** Oil reservoir

**C:** To oil pan

After lubricating rocker **2**, the camshaft bushings, and other components, oil enters oil reservoir **B** to lubricate the cams.

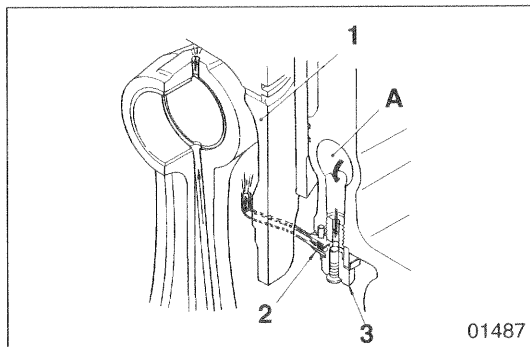

### ● Check valve and oil jet

- 1 Piston
- 2 Oil jet
- 3 Check valve

**A:** Main oil gallery

An oil jet **2** is fitted in the lower part of the main oil gallery **A** for each piston. These oil jets cool the pistons **1** by injecting oil into them. Each oil jet is fitted with a check valve that opens and closes at specified oil pressure levels. At low engine speeds, these check valves **3** close to maintain the required volume of oil in the lubrication system and prevent reductions in oil pressure.

# STRUCTURE AND OPERATION

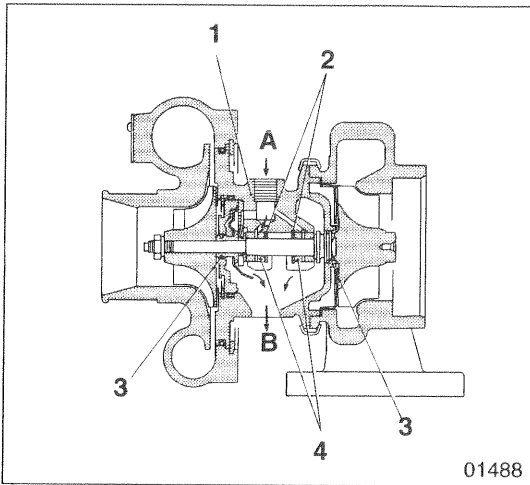

## ● Turbocharger <6D14-T, 15-T, 16-T, 16-TE, 16-TL, 16-TLE>

- 1 Bearing housing
- 2 Snap ring
- 3 Piston ring
- 4 Bearing

A: From main oil gallery  
B: To oil pan

Via an oil pipe, engine oil is delivered from the main oil gallery to the bearing housing 1 to lubricate the inside of the bearing housing. At each end of the turbine wheel shaft, piston ring 3 acts as an oil seal.

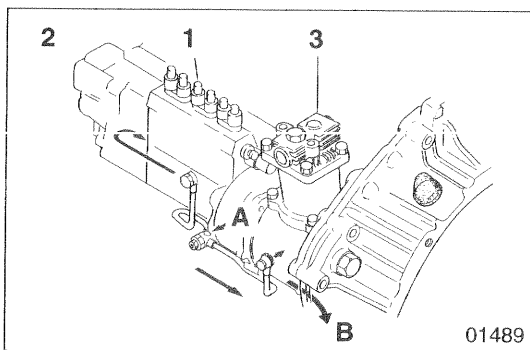

## ● Injection pump

- 1 Injection pump
- 2 Governor
- 3 Air compressor (or injection pump drive)

A: From main oil gallery  
B: To oil pan

Engine oil that has lubricated injection pump 1 and governor 2 returns to the oil pan via the timer case, air compressor 3 (or injection pump drive), and timing gear train.

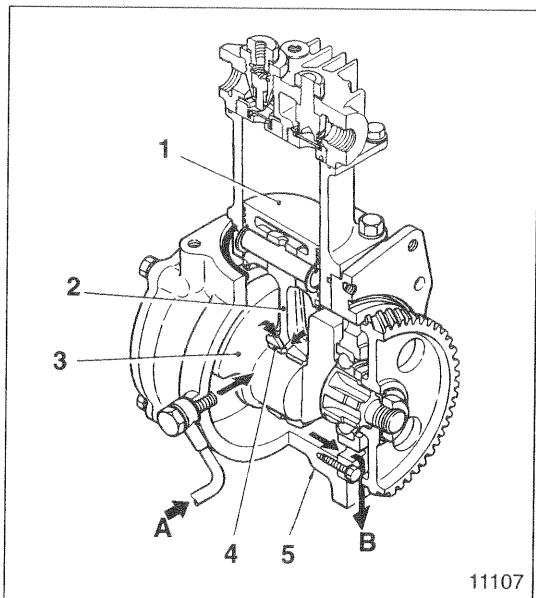

## ● Air compressor

- 1 Piston
- 2 Connecting rod
- 3 Crankshaft
- 4 Connecting rod bushing
- 5 Crankcase

A: From main oil gallery  
B: To oil pan

Engine oil from the main oil gallery splashes onto connecting rod 2 and lubricates connecting rod bushing 4. Piston 1 and the connecting rod's small end are lubricated by oil that is splashed onto them by the rotation of the crankshaft 3.

**● Vacuum pump**

Some of the oil used to lubricate the camshaft bushings is fed to the vacuum pump housing via a flexible hose. After lubricating the vacuum pump vanes, this oil leaves via an outlet at the bottom of the housing and returns to the oil pan.

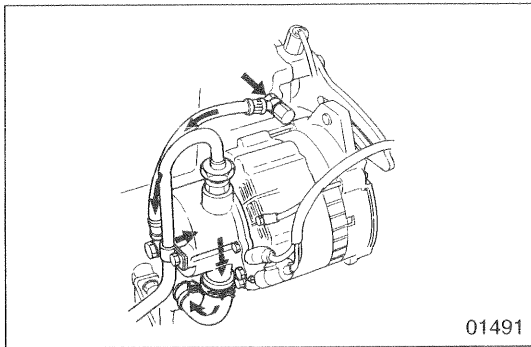

01491

# TROUBLESHOOTING

Symptoms		Possible causes				Remarks
		Engine hard to start	Overheating	Low oil pressure	Excessive oil consumption (oil leakage)	
Oil cooler	Oil cooler element installed poorly		<input type="radio"/>	<input type="radio"/>	<input type="radio"/>	
	Gasket defective		<input type="radio"/>	<input type="radio"/>	<input type="radio"/>	
	O-ring defective		<input type="radio"/>	<input type="radio"/>	<input type="radio"/>	
	Oil cooler element clogged		<input type="radio"/>	<input type="radio"/>		
	Oil cooler element damaged		<input type="radio"/>	<input type="radio"/>	<input type="radio"/>	
	Fatigue in bypass valve spring		<input type="radio"/>			
Oil pump	Oil pump malfunctioning		<input type="radio"/>	<input type="radio"/>		
	Interference between oil pump gear and oil pump case or cover	<input type="radio"/>		<input type="radio"/>		
	Oil pipe poorly fitted		<input type="radio"/>	<input type="radio"/>		
	Oil strainer clogged		<input type="radio"/>	<input type="radio"/>		
	Fatigue in relief valve spring			<input type="radio"/>		
Oil filter	Oil filter fitted poorly				<input type="radio"/>	
	Element clogged		<input type="radio"/>	<input type="radio"/>		
	Fatigue in check valve and bypass check valve springs <A, B type>			<input type="radio"/>		
	O-ring defective			<input type="radio"/>		
Front cover assembly timing gear case	Front oil seal defective				<input type="radio"/>	📖 Gr 11
	Front cover assembly fitted poorly				<input type="radio"/>	📖 Gr 11
Flywheel housing	Rear oil seal defective				<input type="radio"/>	📖 Gr 11
	Gasket fitted poorly				<input type="radio"/>	📖 Gr 11
Fatigue in regulator valve spring				<input type="radio"/>		
Piston cooling oil jet(s) defective			<input type="radio"/>			
Oil working its way up into combustion chamber(s)					<input type="radio"/>	📖 Gr 11
Oil working its way down into combustion chamber(s)					<input type="radio"/>	📖 Gr 11
Oil viscosity too high		<input type="radio"/>				
Unsuitable oil quality			<input type="radio"/>			
Deterioration in oil			<input type="radio"/>			
Fuel mixed with oil			<input type="radio"/>			

## 1. Oil Filter Replacement

<Spin-on type>

### ⓘ Tightening torques

Unit: N · m {kgf · m}

Location	Parts to be tightened	Tightening torque	Remarks
1	Oil filter drain valve <A type>	29 ± 4.9 {3 ± 0.5}	—
2	Oil filter drain plug <B, C type>	7.8 ± 2.0 {0.8 ± 0.2}	—

### 🔧 Special tools

Unit: mm

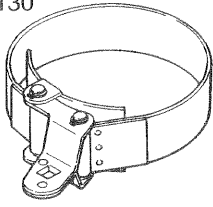
Location	Tool name and shape	Part No.	Application
4	Oil Filter Wrench 	MH061537	Oil filter removal

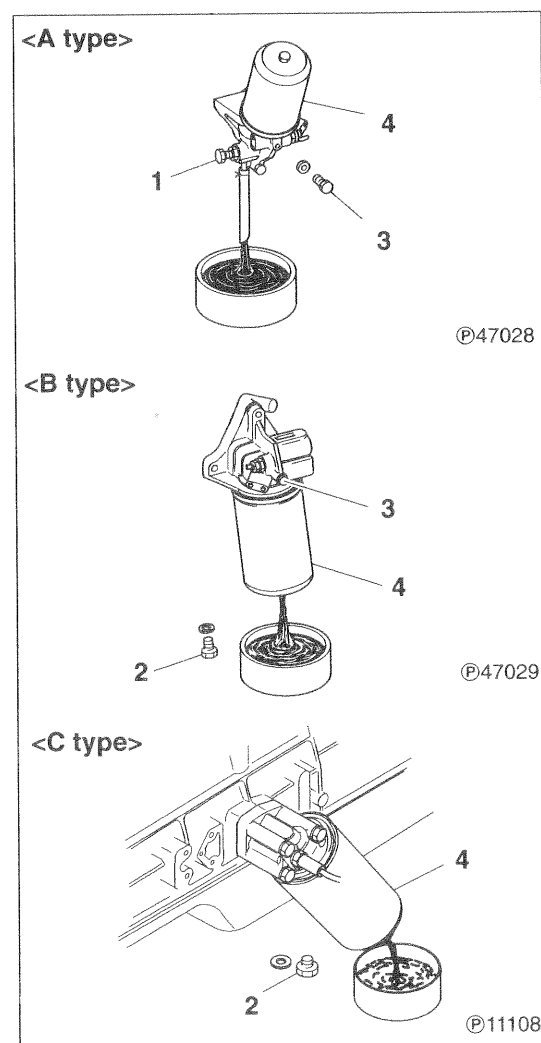

### ⚠ WARNING

- Wipe up any spilled engine oil since it can cause a fire.
- Do not touch oil when the engine is hot since it can inflict severe burns.

### ⚠ CAUTION

When pouring oil into the engine, take care not to spill any on the V-belts. Contact with oil could make the V-belts slip, rendering the cooling system less effective.

For type A or type B oil filter, loosen drain plug 1 or oil filter drain plug 2 and air plug 3 in that order, then drain the oil out of filter 4.

# ON-VEHICLE INSPECTION AND ADJUSTMENT

[Removal]

: Oil Filter Wrench

<A type>

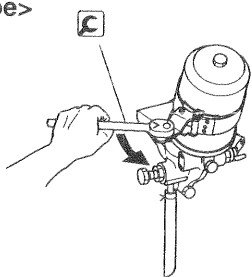

©47030

<B type>

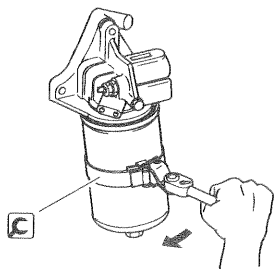

©47031

<C type>

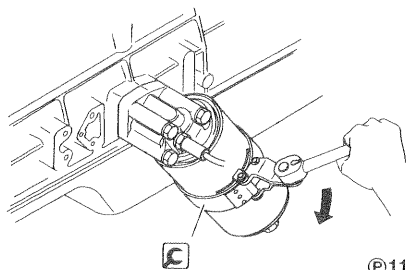

©11109

## &lt;A type&gt;

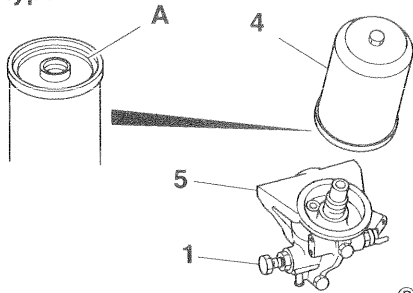

©47032

## &lt;B type&gt;

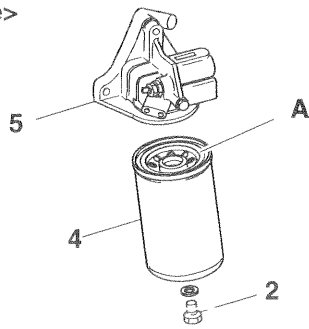

©47033

## &lt;C type&gt;

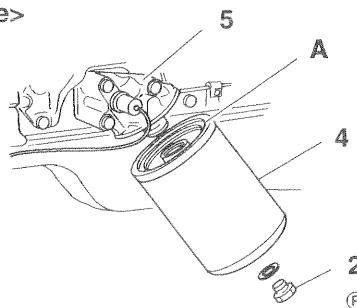

©11110

## [Installation]

- Clean the surface on oil filter head 5 that makes contact with oil filter 4.
- Apply a film of engine oil to gasket area A of filter 4.
- Screw oil filter 4 into oil filter head 5 until gasket area A touches the oil filter head.
- From this position, tighten filter 3 by a further  $1\frac{1}{8}$  to  $1\frac{3}{8}$  of a turn.
- Fit oil filter drain valve 1 or oil filter drain plug 2.
- Start the engine and check that no oil leaks from gasket area A.
- Check the engine oil level and add oil if necessary.

# ON-VEHICLE INSPECTION AND ADJUSTMENT

## <Replaceable-element type>

### ① Tightening torques

Unit: N·m {kgf·m}

Location	Parts to be tightened	Tightening torque	Remarks
1	Oil filter drain valve	$29 \pm 4.9$ { $3.0 \pm 0.5$ }	—
4	Center bolt	$54 \pm 4.9$ { $5.5 \pm 0.5$ }	—

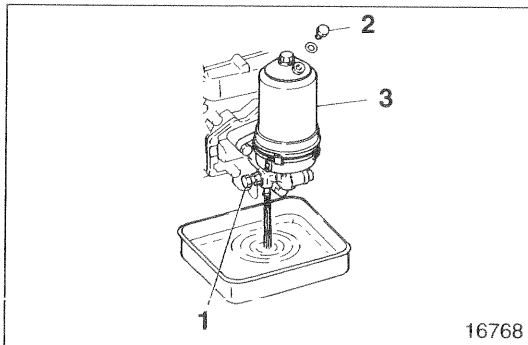

### WARNING

- Wipe up any spilled engine oil since it can cause a fire.
- Do not touch oil when the engine is hot since it can inflict severe burns.

### CAUTION

When pouring oil into the engine, take care not to spill any on the V-belts. Contact with oil could make the V-belts slip, rendering the cooling system less effective.

With a downward-facing oil filter, loosen drain valve plug 1 and air plug 2 in that order, then drain the oil out of filter 3.

#### [Removal]

- 4 Center bolt
- 5 O-ring
- 6 Filter case
- 7 O-ring
- 8 Set spring
- 9 Element
- 10 Filter bracket

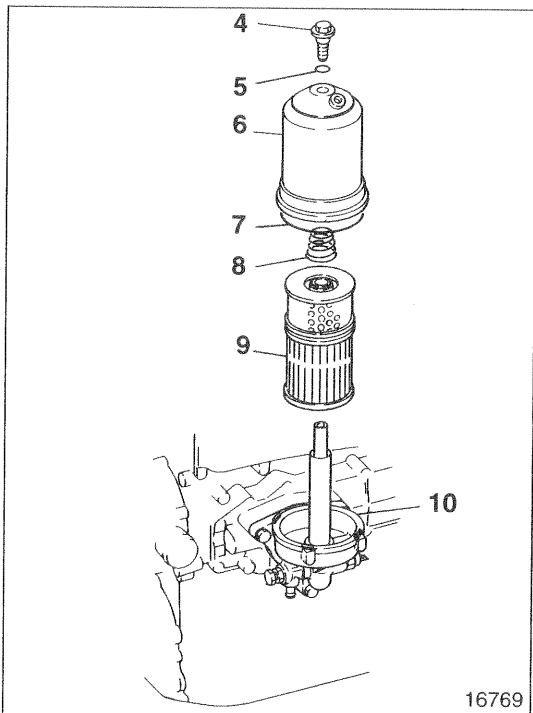

#### [Installation]

Wash all components other than the element in cleaning solvent, then fit the filter in the opposite order from that in which it was removed.

### CAUTION

- If O-ring 7 is twisted when fitted, it may be severed.
- Element 9 cannot be washed and reused.

## 2. Engine Oil Replacement

### ① Tightening torques

Unit: N·m {kgf·m}

Location	Parts to be tightened	Tightening torque	Remarks
2	Oil pan drain plug	69 {7}	—
3	Oil filter drain valve	29 ± 4.9 {3 ± 0.5}	—
4	Oil filter drain plug	7.8 ± 2.0 {0.8 ± 0.2}	—

### 🔧 Lubricants

Location	Points of application	Kinds	Quantity
—	Oil pan dm <sup>3</sup> {L}	General power applications	Non-turbocharged engines: API CC or above Turbocharged engines: API CD or above
		Construction machinery applications	
—	Oil filter dm <sup>3</sup> {L}	Spin-on type: A, B type	Approx. 2.1 {2.1}
		Spin-on type: C type Replaceable-element type	Approx. 2.3 {2.3}

#### <Spin-on type: A type>

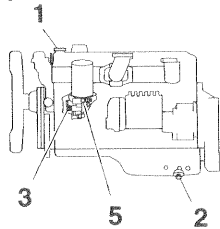

©16770

#### <Spin-on type: B type>

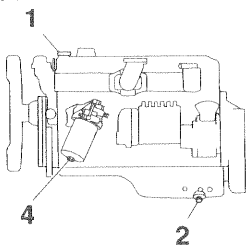

©47034

#### <Spin-on type: C type>

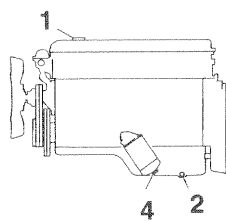

©47096

#### <Replaceable-element type>

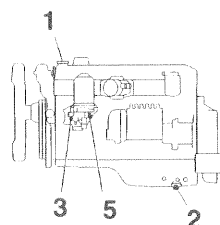

©16772

### WARNING ⚠️

- Wipe up any spilled engine oil since it can cause a fire.
- Do not touch oil when the engine is hot since it can inflict severe burns.

### CAUTION ⚠️

When pouring oil into the engine, take care not to spill any on the V-belts. Contact with oil could make the V-belts slip, rendering the cooling system less effective.

#### [Draining]

- Warm up the engine, then remove oil filler cap 1.
- Remove oil pan drain plug 2, oil filter drain valve 3 or oil filter drain plug 4, and air plug 5. Then, drain the engine oil.

#### [Filling]

Tighten oil pan drain plug 2 and oil filter drain valve 3 or oil filter drain plug 4 to their specified torques, then pour the specified quantity of engine oil into the engine.

# ON-VEHICLE INSPECTION AND ADJUSTMENT

## 3. Oil Pressure Measurement

<Except 6D16-TLE>

### Service standards

Location	Maintenance item		Standard value	Limit	Remedy
—	Oil pressure (at oil temperature 70 to 90°C)	At no-load minimum speed	0.1 MPa {1.0 kgf/cm <sup>2</sup> } or higher	Up to 0.1 MPa {1.0 kgf/cm <sup>2</sup> }	Adjust
		At no-load maximum speed	0.2 to 0.6 MPa {2.0 to 6.1 kgf/cm <sup>2</sup> }	Up to 0.2 MPa {2.0 kgf/cm <sup>2</sup> }	

### ① Tightening torque

Unit: N·m {kgf·m}

Location	Parts to be tightened	Tightening torque	Remarks
1	Engine oil pressure gauge unit	15 to 22 {1.5 to 2.2}	Check with engine cold

### 🔧 Sealant

Location	Points of application	Specified sealant	Quantity
1	Wrap around thread of engine oil pressure gauge unit	Teflon tape	3 <sup>1</sup> / <sub>2</sub> turns

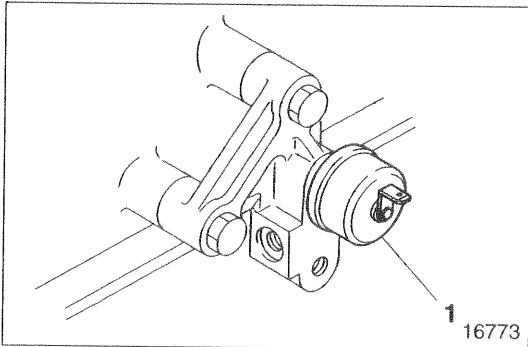

- Remove engine oil pressure gauge unit 1.

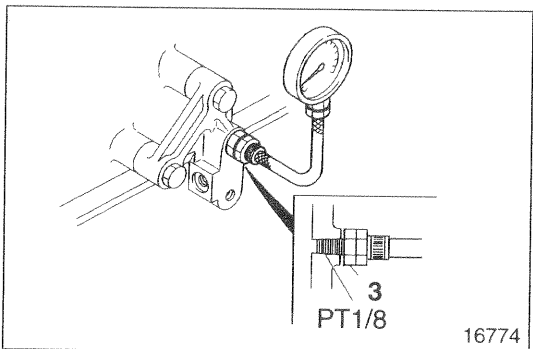

- Fit adapter 3 onto the engine oil pressure gauge unit mounting, then fit the oil pressure gauge onto the adapter.
- Warm up the engine until the oil temperature reaches 70 to 90°C.
- Measure the oil pressure at no-load minimum speed and at no-load maximum speed. If the measured values are below the specified standard values, overhaul the lubrication system.
- After taking measurements, fit oil pressure gauge unit 1 and tighten it to the specified torque.

### NOTE

Oil pressure gauge unit 1 must be fitted with the engine cold.

## &lt;6D16-TLE&gt;

## Service standards

Location	Maintenance item	Standard value	Limit	Remedy	
—	Oil pressure (at oil temperature 70 to 90°C)	At no-load minimum speed	0.1 MPa {1.0 kgf/cm <sup>2</sup> } or higher	Up to 0.1 MPa {1.0 kgf/cm <sup>2</sup> }	Adjust
		At no-load maximum speed	0.2 to 0.6 MPa {2.0 to 6.1 kgf/cm <sup>2</sup> }	Up to 0.2 MPa {2.0 kgf/cm <sup>2</sup> }	Adjust

## ⓘ Tightening torque

Unit: N·m {kgf·m}

Location	Parts to be tightened	Tightening torque	Remarks
1	Engine oil pressure switch	15 to 22 {1.5 to 2.2}	Tighten with engine cold

## 🔧 Sealant

Location	Points of application	Specified sealant	Quantity
1	Wrap around thread of engine oil pressure switch	Teflon tape	3 <sup>1</sup> / <sub>2</sub> turns

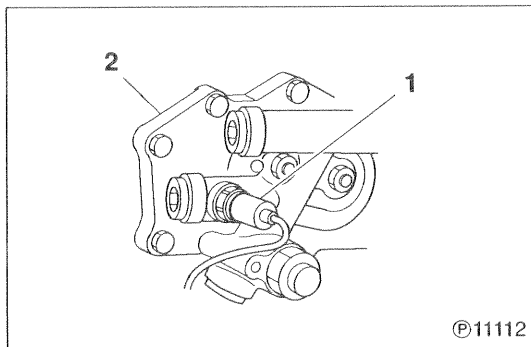

- Remove engine oil pressure switch 1.

2: Oil cooler

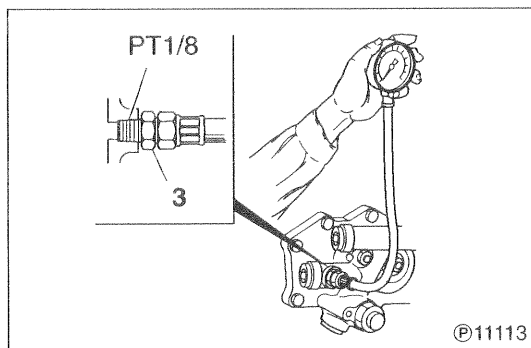

- Fit adapter 3 into the opening from which the engine oil pressure switch has been removed. Install an oil pressure gauge onto the adapter.
- Run the engine until oil temperature reaches 70 – 90°C.
- Measure the oil pressure at both no-load minimum and maximum speeds. If either of the measured values is below the limit pressures, overhaul the lubrication system.
- Fit engine oil pressure switch 1 and tighten it to the specified torque.

**NOTE**

Installation of engine oil pressure switch 1 must be performed while the engine is cold.

# OIL PAN, OIL JET, AND OIL LEVEL SENSOR

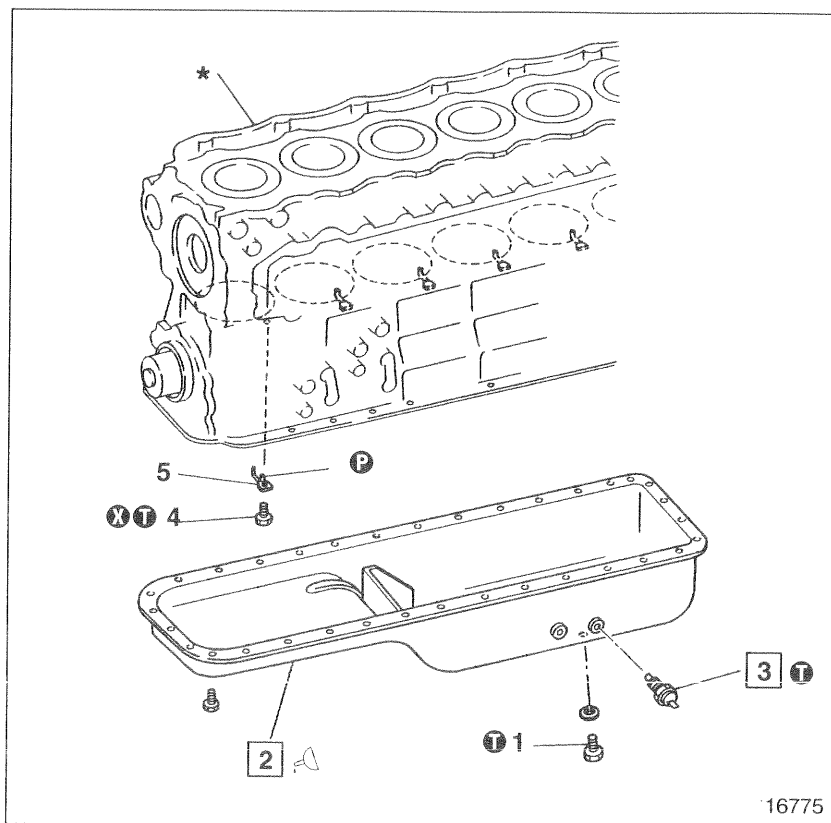

## ● Disassembly sequence

- 1 Drain plug
- 2 Oil pan
- 3 Engine oil temperature sensor
- 4 Check valve
- 5 Oil jet

\*: Crankcase assembly Gr 11

**P**: Locating pin

**X**: Non-reusable part

## ● Assembly sequence

Reverse the order of disassembly.

## CAUTION

Do not tighten check valve 4 in excess of the specified torque. Excessive tightness can cause defective operation, resulting in scorching of the engine.

16775

## Service standards

Location	Maintenance item	Standard value	Limit	Remedy	
3	Resistance of engine oil temperature sensor (between terminal ① and body)	50°C	(136 Ω)	—	Replace
		80°C	48 ± 5 Ω	—	
		100°C	27.2 ± 2 Ω	—	

Figures in parentheses are approximate.

## ① Tightening torques

Unit: N · m {kgf · m}

Location	Parts to be tightened	Tightening torque	Remarks
1	Drain plug	69 {7}	—
3	Engine oil temperature sensor	34 ± 6.9 {3.5 ± 0.7}	—
4	Check valve	34 {3.5}	—

## Sealant

Location	Points of application	Specified sealant	Quantity
2	Crankcase mounting surface of oil pan	THREEBOND 1207C	As required

## ◆ Service procedure

### 2 Fitting oil pan

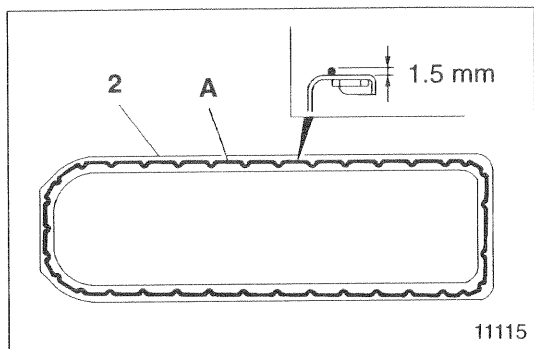

### CAUTION

- Clean the oil pan mounting surface and ensure it is free of oily substances before applying sealant A.
- Carefully mount oil pan 2 exactly in the correct position. Ensure that sealant A does not spread to other areas.
- After fitting oil pan 2, wait at least one hour before starting the engine.
- Reapply sealant A whenever the oil pan mounting bolts have been loosened.

### 3 Engine oil temperature sensor

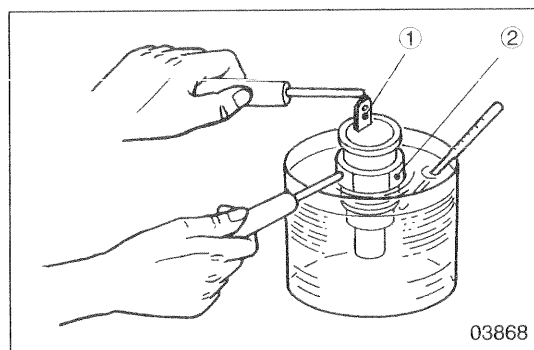

- Place engine oil temperature sensor 3 in a container of engine oil.
- Heat the engine oil until it reaches each of the temperatures in the service standards table.
- At each of the given temperatures, measure the electrical resistance between the engine oil temperature sensor's terminal ① and body ②.
- If the resistance values do not match those in the service standards table, replace the engine oil temperature sensor 3.

# OIL PUMP AND OIL STRAINER

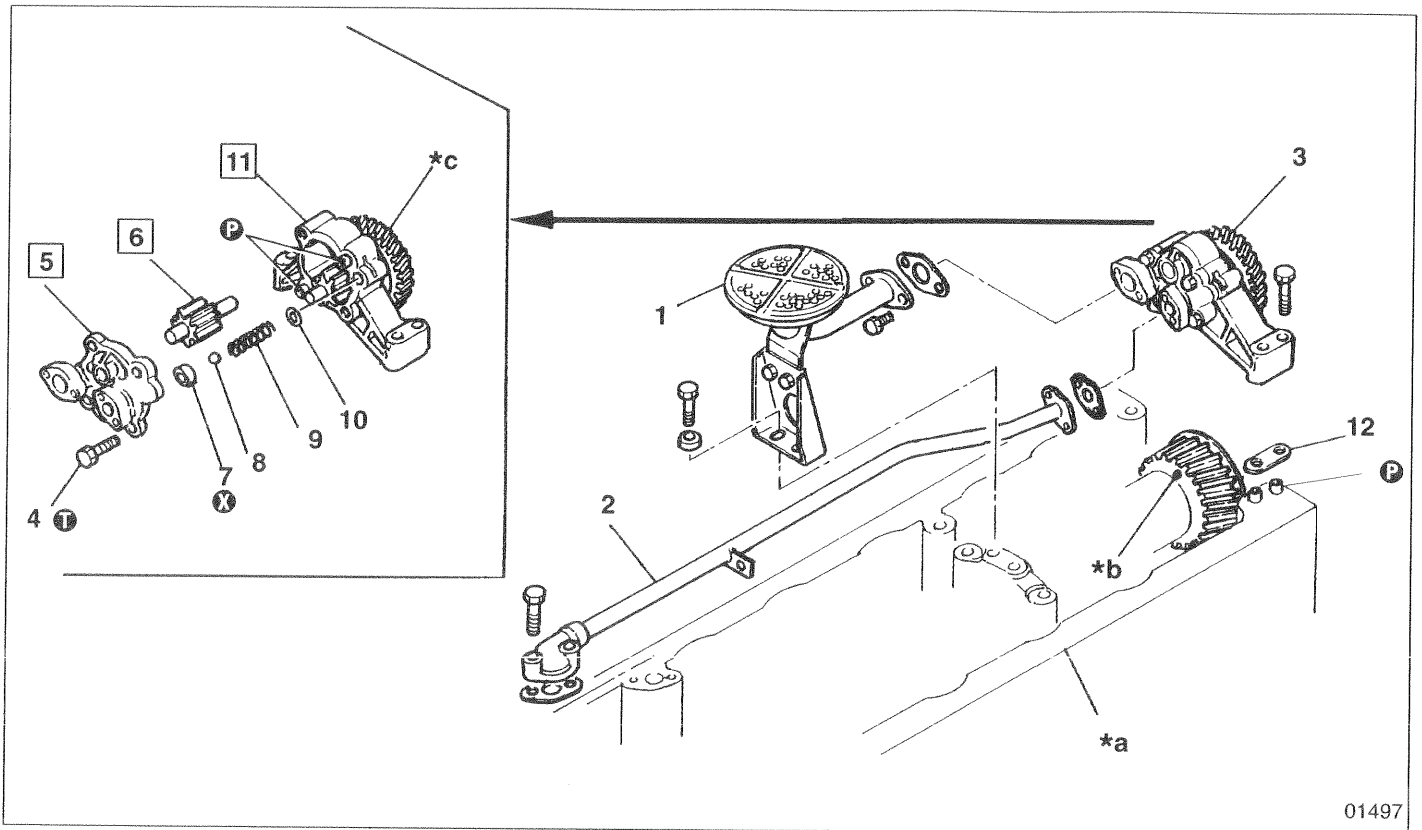

## ● Inspection before disassembly

📖 P.12-23

## ● Disassembly sequence

- |                        |                           |
|------------------------|---------------------------|
| 1 Oil strainer         | 8 Relief valve            |
| 2 Oil pipe             | 9 Relief valve spring     |
| 3 Oil pump assembly    | 10 Washer                 |
| 4 Bolt                 | 11 Gear and case assembly |
| 5 Cover                | 12 Shim                   |
| 6 Driven gear assembly |                           |
| 7 Ring                 |                           |

\*a: Crankcase assembly 📖 Gr 11

\*b: Crankshaft gear 📖 Gr 11

\*c: Oil pump gear

Ⓟ: Locating pin

ⓧ: Non-reusable part

## NOTE

- Do not remove parts #7 to 10 unless they are defective.
- Gear and case assembly 11 is an integrated unit and cannot be disassembled. If any defect is apparent, replace the whole unit.
- Do not remove oil strainer 1 and oil pipe 2 from oil pump assembly 3 unless they are defective. Remove those three as a unit.

## ● Assembly sequence

Reverse the order of disassembly.

**Service standards**

Unit: mm

Location	Maintenance item	Maintenance item	Standard value (Basic diameter in [ ])	Limit	Remedy
5, 11	Clearance between drive gear shaft and inner diameter of cover		[20] 0.04 to 0.07	0.15	Replace
5, 6, 11	Clearance between driven gear shaft and inner diameter of case and cover		[20] 0.04 to 0.07	0.15	Replace
6, 11	Clearance between case and tooth tips of each gear		0.10 to 0.19	0.2	Replace
	Difference between height of each gear and depth of case		0.06 to 0.11	0.15	
8	Relief valve opening pressure		980 to 1175 kPa {10 to 12 kgf/cm <sup>2</sup> }	—	Replace
9	Relief valve spring load (installed length = 30)		84 N {8.6 kgf}	—	Replace
*b, *c	Backlash between oil pump gear and crankshaft gear	Without PTO	0.08 to 0.18	0.35	Adjust with shims
		With PTO	0.10 to 0.22		

**Tightening torque**

Unit: N · m {kgf · m}

Location	Parts to be tightened	Tightening torque	Remarks
4	Oil pump cover mounting bolt	25 ± 4.9 {2.5 ± 0.5}	—

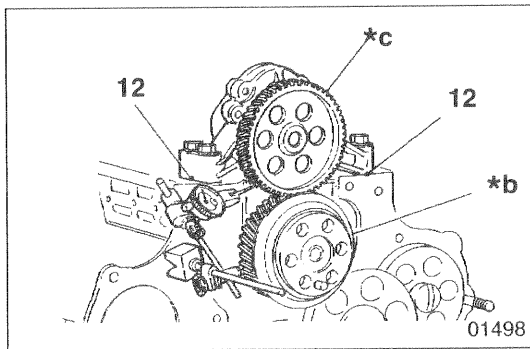

**Service procedure**

**Inspection before disassembly**

Measure the backlash between oil pump gear \*c and crankshaft gear \*b. If the amount of backlash exceeds the specified limit, adjust it with shims 12.

Shim thickness	Change in amount of backlash
0.1 mm	0.073 mm
0.2 mm	0.146 mm

**NOTE**

Shim 12 must have the same thickness on the left and right sides.

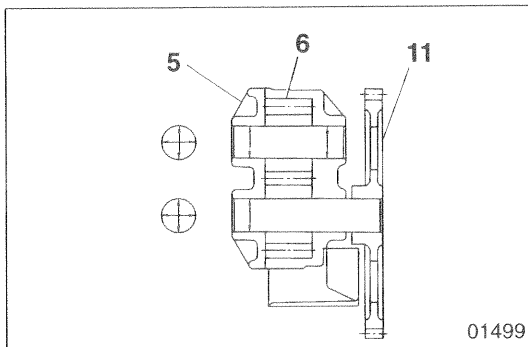

**5 6 11 Inspection of cover, driven gear assembly, and gear and case assembly**

Measure the clearance between each gear shaft and the internal diameters of the cover and case.

# OIL PUMP AND OIL STRAINER

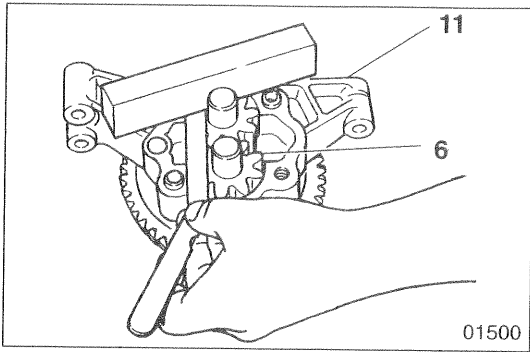

**6 11** Inspection of driven gear assembly and of gear and case assembly

**(1) Differences between gear heights and case depth**

Replace any component whose measurement is out of specification.

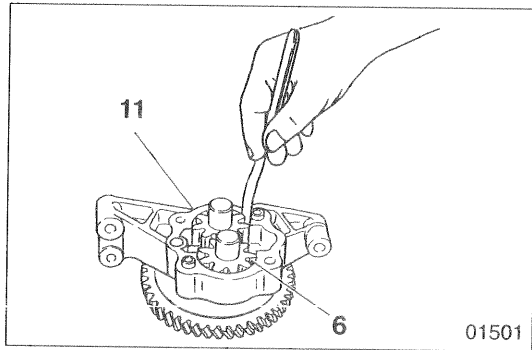

**(2) Clearance between gear teeth and case**

Replace any component whose measurement is out of specification.

---

**MEMO**

---

# OIL FILTER <Spin-on Type>

<A type>

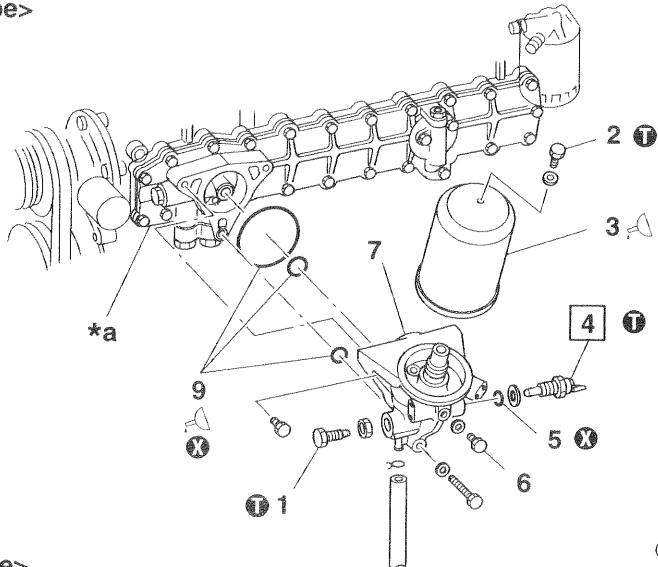

©47035

<B type>

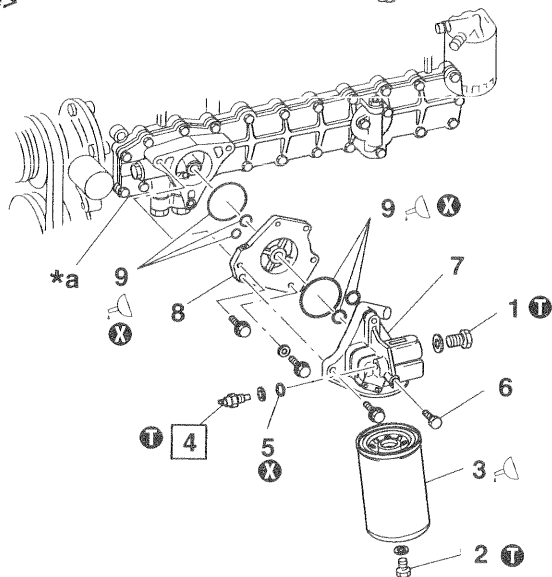

©47036

<C type>

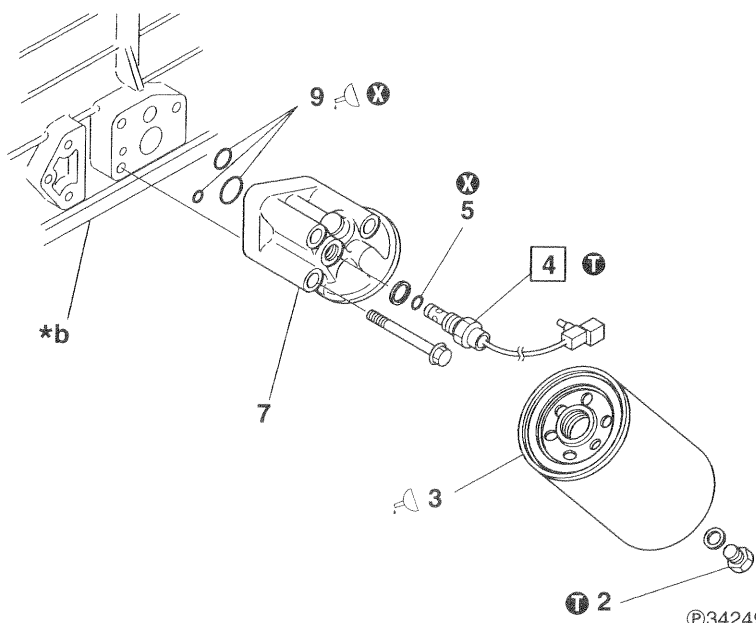

©34249

## ● Disassembly sequence

- 1 Oil filter drain valve <A, B type>
- 2 Oil filter drain plug
- 3 Oil filter P.12-13
- 4 Engine oil bypass alarm switch
- 5 O-ring
- 6 Air plug <A, B type>
- 7 Oil filter head
- 8 Spacer <B type>
- 9 O-ring

\*a: Oil cooler P.12-30

\*b: Crankcase assembly Gr 11

⊗: Non-reusable part

## ● Assembly sequence

Reverse the order of disassembly.

**WARNING** 

- Wipe up any spilled engine oil since it can cause a fire.
- Do not touch oil when the engine is hot since it can inflict severe burns.

**CAUTION** 

When pouring oil into the engine, take care not to spill any on the V-belts. Contact with oil could make the V-belts slip, rendering the cooling system less effective.

**Service standards**

Location	Maintenance item	Standard value	Limit	Remedy
4	Engine oil bypass alarm switch valve opening pressure	$0.19_{-0}^{+0.05}$ MPa { $1.9_{-0}^{+0.5}$ kgf/cm <sup>2</sup> }	—	Replace

**Tightening torques**

Unit: N·m {kgf·m}

Location	Parts to be tightened	Tightening torque	Remarks
1	Oil filter drain valve <A, B type>	$29 \pm 4.9$ { $3.0 \pm 0.5$ }	—
2	Oil filter drain plug	$7.8 \pm 2.0$ { $0.8 \pm 0.2$ }	—
4	Engine oil bypass alarm switch	$49 \pm 4.9$ { $5.0 \pm 0.5$ }	—

**Lubricant**

Location	Points of application	Specified lubricant	Quantity
3	Apply thin film to oil filter gasket area  P.12-13	Engine oil	As required
9	Apply to O-rings	Engine oil	As required

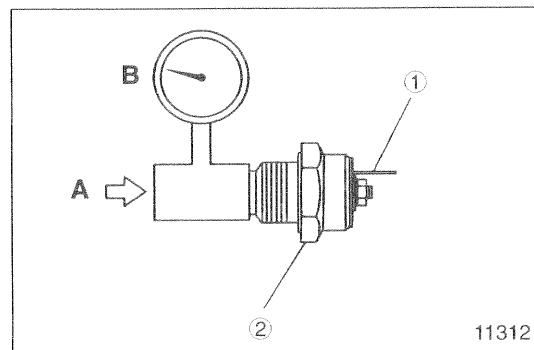
**Service procedure****4 Inspection of engine oil bypass alarm switch**

Carry out the following inspections and replace the engine oil bypass alarm switch 4 if the results are unsatisfactory:

- With no air pressure **A** applied to engine oil bypass alarm switch 4, check that there is no electrical continuity between the terminal ① and body ② of the engine oil bypass alarm switch.
- Starting with pressure of 0 kPa {0 kgf/cm<sup>2</sup>}, gradually increase the air pressure **A** on engine oil bypass alarm switch 4. Note the air pressure when electrical continuity appears between the terminal ① and body ②. Verify that this pressure conforms with the specified standard value.

**B**: Air pressure gauge

# OIL FILTER <Replaceable-element Type>

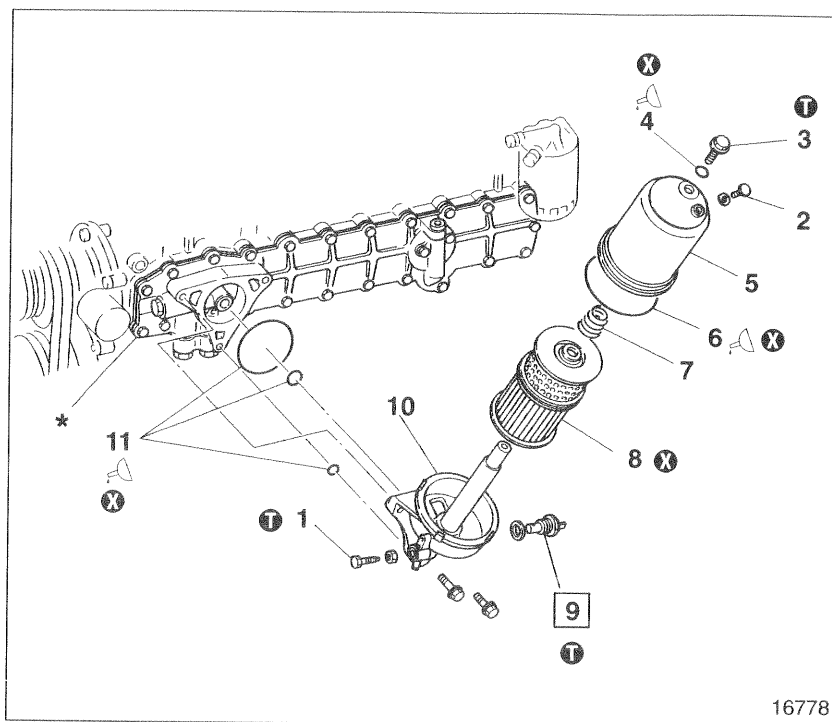

## ● Disassembly sequence

- 1 Oil filter drain valve
- 2 Air plug
- 3 Center bolt
- 4 O-ring
- 5 Filter case
- 6 O-ring
- 7 Set spring
- 8 Element
- 9 Engine oil bypass alarm switch
- 10 Filter bracket
- 11 O-ring

\*: Oil cooler P.12-30

X: Non-reusable part

## ● Assembly sequence

Reverse the order of disassembly.

## WARNING

- Wipe up any spilled engine oil since it can cause a fire.
- Do not touch oil when the engine is hot since it can inflict severe burns.

## CAUTION

When pouring oil into the engine, take care not to spill any on the V-belts. Contact with oil could make the V-belts slip, rendering the cooling system less effective.

## Service standards

Location	Maintenance item	Standard value	Limit	Remedy
9	Engine oil bypass alarm switch valve opening pressure	145 <sup>+50</sup> / <sub>0</sub> kPa {1.5 <sup>+0.5</sup> / <sub>0</sub> kgf/cm <sup>2</sup> }	—	Replace

## Tightening torques

Unit: N · m {kgf · m}

Location	Parts to be tightened	Tightening torque	Remarks
1	Oil filter drain valve	29 ± 4.9 {3.0 ± 0.5}	—
3	Center bolt	54 ± 4.9 {5.5 ± 0.5}	—
9	Engine oil bypass alarm switch	49 ± 4.9 {5.0 ± 0.5}	—

## Lubricant

Location	Points of application	Specified lubricant	Quantity
4, 6, 11	Apply to O-rings	Engine oil	As required

## ◆ Service procedure

### 9 Inspection of engine oil bypass alarm switch

Carry out the following inspections and replace the engine oil bypass alarm switch 9 if the results are unsatisfactory:

- With no air pressure **A** applied to engine oil bypass alarm switch 9, check that there is no electrical continuity between the terminal ① and body ② of the engine oil bypass alarm switch.
- Starting with pressure of 0 kPa {0 kgf/cm<sup>2</sup>}, gradually increase the air pressure **A** on engine oil bypass alarm switch 9. Note the air pressure when electrical continuity appears between the terminal ① and body ②. Verify that this pressure conforms with the specified standard value.

**B**: Air pressure gauge

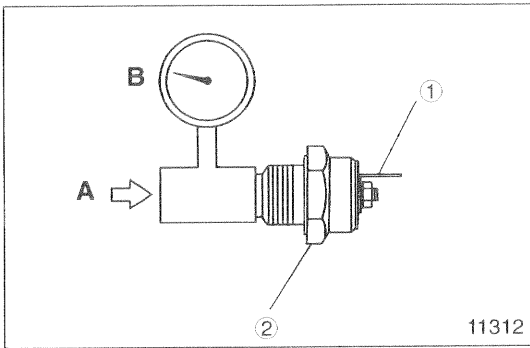

# OIL COOLER <Except 6D16-TLE>

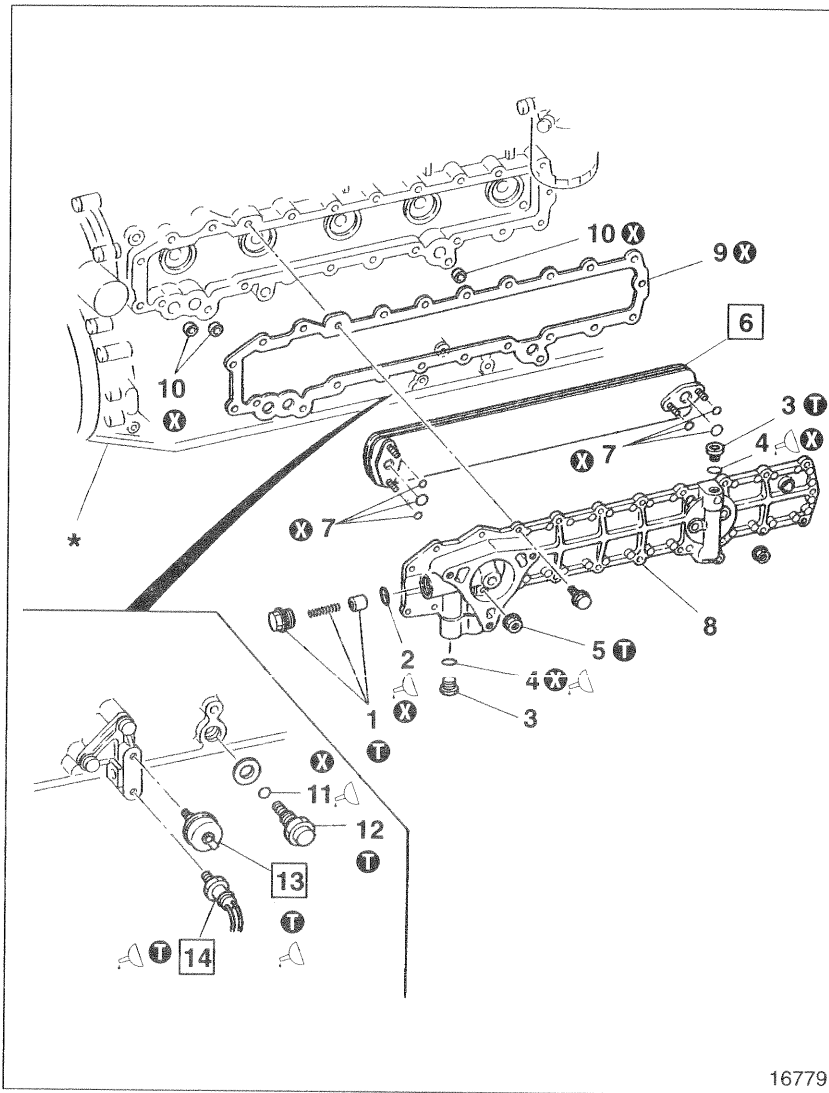

## ● Disassembly sequence

- 1 Bypass valve
- 2 O-ring
- 3 Oil cooler plug
- 4 O-ring
- 5 Nut
- 6 Oil cooler element
- 7 O-ring
- 8 Oil cooler cover
- 9 Gasket
- 10 O-ring
- 11 O-ring
- 12 Regulator valve P.12-34
- 13 Engine oil pressure gauge unit
- 14 Engine oil pressure switch

\*: Crankcase assembly Gr 11

⊗: Non-reusable part

## ● Assembly sequence

Reverse the order of disassembly.

16779

## Service standards

Location	Maintenance item	Standard value	Limit	Remedy
1	Oil cooler bypass valve opening pressure	295 ± 20 kPa {3.0 ± 0.2 kg/cm <sup>2</sup> }	—	—
6	Oil cooler element air leakage (air pressure of 980 kPa {10 kgf/cm <sup>2</sup> } for 15 seconds)	0 cc	—	Replace
14	Operating pressure of engine oil pressure switch	49 ± 9.8 kPa {0.5 ± 0.1 kgf/cm <sup>2</sup> }	—	Replace

## ⓘ Tightening torques

Unit: N · m {kgf · m}

Location	Parts to be tightened	Tightening torque	Remarks
1	Bypass valve	20 ± 4.9 {2.0 ± 0.5}	—
3	Oil cooler plug	25 ± 4.9 {2.5 ± 0.5}	—
5	Nut (oil cooler element mounting)	20 ± 4.9 {2.0 ± 0.5}	—
12	Regulator valve	105 ± 9.8 {11 ± 1}	—
13	Engine oil pressure gauge unit	15 to 22 {1.5 to 2.2}	—
14	Engine oil pressure switch	15 to 22 {1.5 to 2.2}	—

## Lubricant and/or sealant

Location	Points of application	Specified lubricant and/or sealant	Quantity
2, 4, 11	Apply to O-rings	Engine oil	As required
13, 14	Wrap around thread of engine oil pressure gauge unit and engine oil pressure switch	Teflon tape	3 <sup>1</sup> / <sub>2</sub> turns

### ◆ Service procedure

#### ● Cleaning

- Check whether carbon deposits or sludge have accumulated in the oil passages of oil cooler element **6** and oil cooler cover **8** or in the oil cooler's bypass arrangement. Remove any deposits with cleaning sealant.
- Clean out any water scale or fur that has accumulated in the oil cooler element **6** or oil cooler cover **8**.  Gr 14

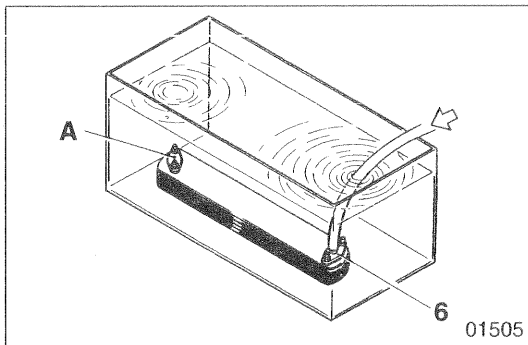

#### **6** Inspection of oil cooler element

Plug outlet **A** of oil cooler element **6** and connect a hose to the oil inlet. Then, immerse the oil cooler element in a tank of water.

Apply the specified air pressure via the hose and check that no air leaks from the oil cooler element.

If any air leaks, replace the oil cooler element.

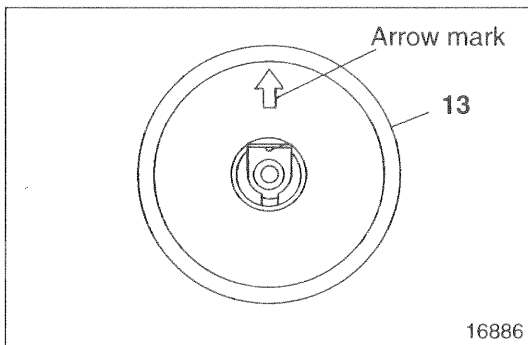

#### **13** Engine oil pressure gauge unit

If the engine oil pressure gauge unit **13** is installed horizontally, it must be fitted with its arrow pointing upward.

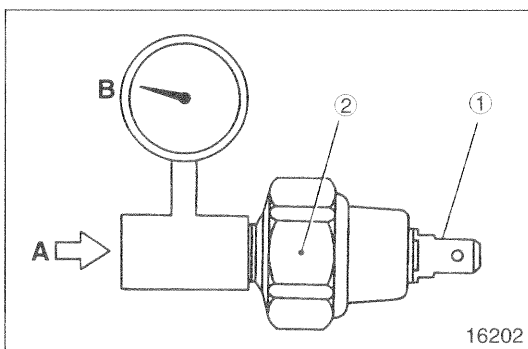

#### **14** Inspection of engine oil pressure switch

Perform the following checks, and if any fault is found, replace the engine oil pressure switch **14**.

##### • Inspection by not applying air pressure

Make sure that there is continuity between terminals ① and ② (body).

##### • Inspection by applying air pressure

- Gradually apply air pressure **A** to the switch starting from 0 kPa {0 kgf/cm<sup>2</sup>}.

- Measure the degree of air pressure at the moment when continuity is not detected between terminals ① and ② (body), and make sure to confirm if the value meets the standard.

**B**: Air pressure gauge

# OIL COOLER <6D16-TLE>

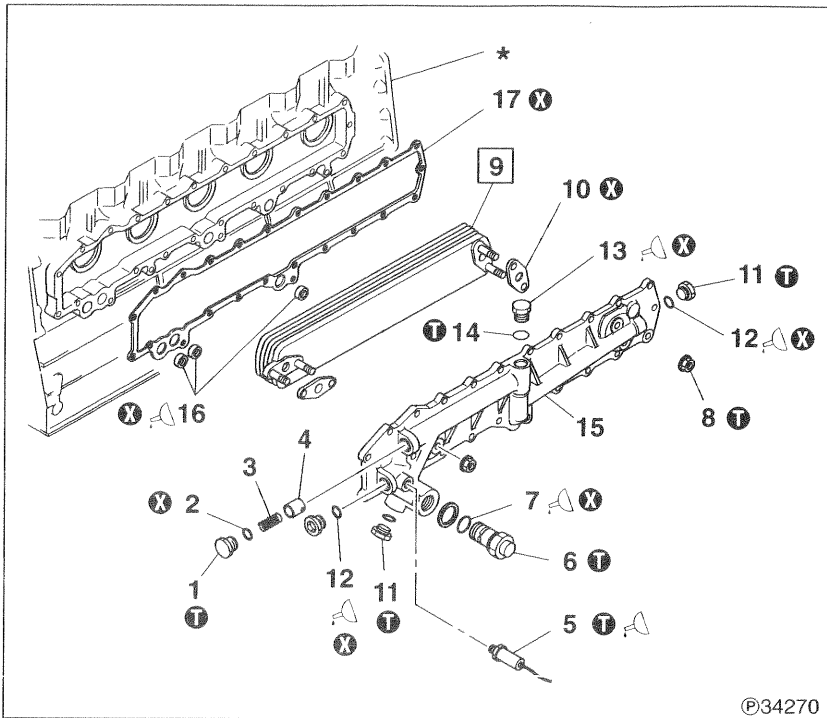

## ● Disassembly sequence

- 1 Bypass valve plug
- 2 O-ring
- 3 Bypass valve spring
- 4 Bypass valve
- 5 Engine oil pressure switch
- 6 Regulator valve P.12-34
- 7 O-ring
- 8 Nut
- 9 Oil cooler element
- 10 Gasket
- 11 Oil cooler plug
- 12 O-ring
- 13 Oil cooler plug
- 14 O-ring
- 15 Oil cooler cover
- 16 O-ring
- 17 Gasket

\*: Crankcase assembly Gr 11

: Non-reusable part

## ● Assembly sequence

Reverse the order of disassembly.

## Service standards

Unit: mm

Location	Maintenance item	Standard value	Limit	Remedy
3	Bypass valve spring	Free length	$104.3 \pm 1$	—
		Spring load (Installed length)	$84 \pm 3N$ { $8.6 \pm 0.3$ kgf}	—
5	Operating pressure of engine oil pressure switch	$49 \pm 9.8$ kPa { $0.5 \pm 0.1$ kgf/cm <sup>2</sup> }	—	Replace
9	Oil cooler element air leakage (Apply air pressure of 1000 kPa {10.2 kgf/cm <sup>2</sup> } for 15 seconds.)	$0$ cm <sup>3</sup> {0mL}	—	Replace

## Tightening torques

Unit: N · m {kgf · m}

Location	Parts to be tightened	Tightening torque	Remarks
1	Bypass valve plug	$34.3 \pm 4.9$ { $3.5 \pm 0.5$ }	—
5	Engine oil pressure switch	15 to 22 {1.5 to 2.2}	—
6	Regulator valve	98 to 118 {10 to 12}	—
8	Nut (for fixing oil cooler element)	$20 \pm 4.9$ { $2.0 \pm 0.5$ }	—
11	Oil cooler plug	$25 \pm 4.9$ { $2.5 \pm 0.5$ }	—
13	Oil cooler plug	$34.5 \pm 4.9$ { $3.5 \pm 0.5$ }	—

## Lubricant and/or sealant

Location	Points of application	Specified lubricant and/or sealant	Quantity
5	Thread of engine oil pressure switch	Teflon tape	Wrap around 3 <sup>1</sup> / <sub>2</sub> turns
7, 12, 14, 16	O-rings on oil cooler	Engine oil	As required

## ◆ Service procedure

### ● Cleaning

- Check whether carbon deposits or sludge have accumulated in the oil passages of oil cooler element **9** and in the oil cooler's bypass arrangement. Remove any deposits with cleaning sealant.
- Clean out any water scale or fur that has accumulated in the oil cooler element **9** or oil cooler cover **15**.  Gr 14

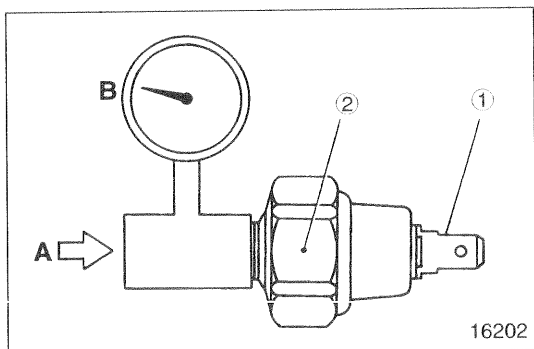

### 5 Inspection of engine oil pressure switch

Perform the following checks, and if any fault is found, replace the engine oil pressure switch **5**.

#### ● Inspection by not applying air pressure

Make sure that there is continuity between terminals **1** and **2** (body).

#### ● Inspection by applying air pressure

- Gradually apply air pressure **A** to the switch starting from 0 kPa {0 kgf/cm<sup>2</sup>}.
- Measure the degree of air pressure at the moment when continuity is not detected between terminals **1** and **2** (body), and make sure to confirm if the value meets the standard.

**B**: Air pressure gauge

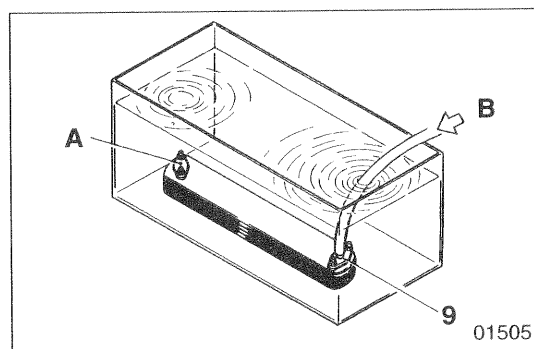

### 9 Inspection of oil cooler element

Plug outlet **A** of oil cooler element **9** and connect a hose to the oil inlet. Then, immerse the oil cooler element in a tank of water.

Apply the specified air pressure **B** via the hose and check that no air leaks from the oil cooler element.

If any air leaks, replace the oil cooler element.

# REGULATOR VALVE

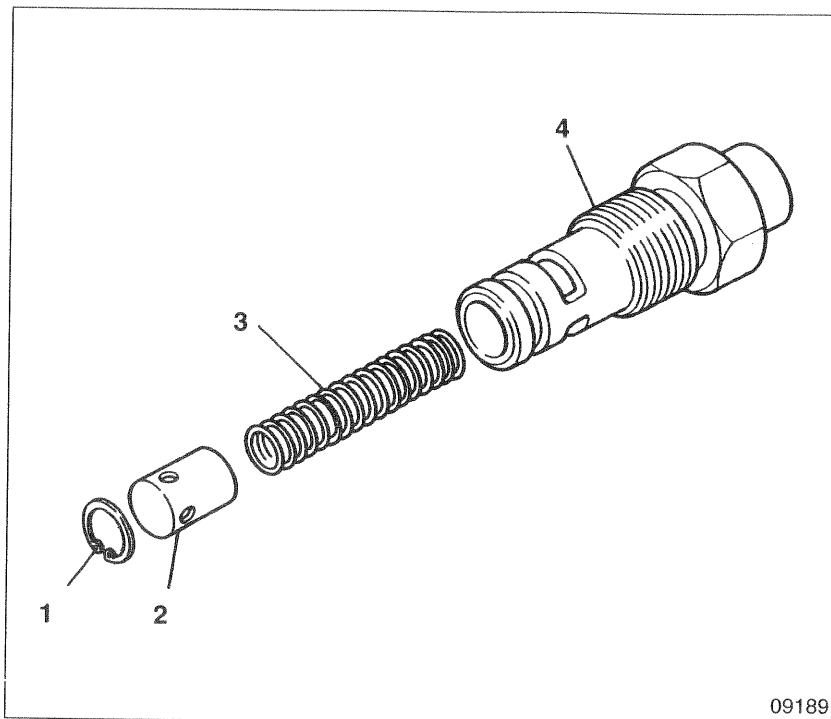

## ● Disassembly sequence

- 1 Snap ring
- 2 Valve
- 3 Spring
- 4 Body

## ● Assembly sequence

Reverse the order of disassembly.

[Installation]

📖 P.12-30, 32

09189

## Service standards

Location	Maintenance item	Standard value (Basic diameter in [ ])	Limit	Remedy
3	Regulator valve spring load (installed length = 48.3 mm)	76 to 80 N {7.8 to 8.2 kgf}	—	—
—	Regulator valve opening pressure	390 ± 29 kPa {4.0 ± 0.3 kgf/cm <sup>2</sup> }	—	—

# GROUP 13A FUEL AND ENGINE CONTROL

<b>SPECIFICATIONS</b> .....	<b>13A-2</b>
<b>STRUCTURE AND OPERATION</b>	
1. Fuel System .....	13A-4
2. Fuel Filter .....	13A-5
3. Secondary Fuel Filter .....	13A-5
4. Water Separator .....	13A-6
5. Injection Pump .....	13A-6
6. Governor .....	13A-9
7. Feed Pump .....	13A-11
8. Automatic Timer .....	13A-12
9. Boost Compensator .....	13A-14
10. Injection Pump Drive .....	13A-15
11. Injection Nozzle .....	13A-15
<b>TROUBLESHOOTING</b> .....	<b>13A-18</b>
<b>ON-VEHICLE INSPECTION AND ADJUSTMENT</b>	
1. Checking and Adjusting Injection Timing .....	13A-22
2. Checking and Adjusting Minimum and Maximum No-load Speeds .	13A-25
3. Cleaning Fuel Feed Pump Gauze Filter .....	13A-26
<b>FUEL FILTER</b> .....	<b>13A-28</b>
<b>SECONDARY FUEL FILTER</b> .....	<b>13A-30</b>
<b>WATER SEPARATOR</b> .....	<b>13A-31</b>
<b>INJECTION PUMP</b>	
<Oldham's Coupling Type> .....	13A-32
<Laminated Coupling Type> .....	13A-34
<b>INJECTION PUMP DRIVE</b>	
<Oldham's Coupling Type> .....	13A-40
<Laminated Coupling Type> .....	13A-44
<b>INJECTION NOZZLE</b>	
<1-spring Type> .....	13A-48
<2-spring Type: BOSCH AUTOMOTIVE SYSTEMS> .....	13A-52
<2-spring Type: DENSO> .....	13A-62

# SPECIFICATIONS

## Injection Pump

Engine model Item	6D14	6D14-T		6D15-T	
	STD	STD	OPT	STD	OPT
Model	Bosch A	Bosch A	Bosch A	Bosch A	Bosch A
Governor type	RSV-type all-speed mechanical governor	RSV-type all-speed mechanical governor	RFD-type minimum-maximum mechanical governor	RSV-type all-speed mechanical governor	RFD-type minimum-maximum mechanical governor
Feed pump type	KE	KE	KE	KE	KE
Automatic timer type	SA-type mechanical timer	SA-type mechanical timer	SA-type mechanical timer	—	—
Manufacturer	DENSO	BOSCH AUTOMOTIVE SYSTEMS	BOSCH AUTOMOTIVE SYSTEMS	BOSCH AUTOMOTIVE SYSTEMS	BOSCH AUTOMOTIVE SYSTEMS

Engine model Item	6D16, 16-E			6D16-T, 16-TE	
	STD	OPT	OPT	STD	OPT
Model	Bosch A	Bosch A	Bosch AD	Bosch AD	Bosch AD
Governor type	RSV-type all-speed mechanical governor	RFD-type minimum-maximum mechanical governor	RSV-type all-speed mechanical governor	RSV-type all-speed mechanical governor	RFD-type minimum-maximum mechanical governor
Feed pump type	KE	KE	KE	KE	KE
Automatic timer type	SA-type mechanical timer	SA-type mechanical timer	—	SA-type mechanical timer	SA-type mechanical timer
Manufacturer	DENSO	BOSCH AUTOMOTIVE SYSTEMS	BOSCH AUTOMOTIVE SYSTEMS	BOSCH AUTOMOTIVE SYSTEMS	BOSCH AUTOMOTIVE SYSTEMS

Engine model Item	6D16-TL	6D16-TLE	
	STD	STD	OPT
Model	Bosch AD	Bosch MD	Bosch MD
Governor type	RFD-type minimum-maximum mechanical governor	RSV-type all-speed mechanical governor	RED-IV-type electronic governor
Feed pump type	KE	KE	KE
Automatic timer type	SA-type mechanical timer	SPG mechanical timer	SPG mechanical timer
Manufacturer	BOSCH AUTOMOTIVE SYSTEMS	BOSCH AUTOMOTIVE SYSTEMS	BOSCH AUTOMOTIVE SYSTEMS

## Injection Nozzle

Engine model	6D14	6D14-T		6D15-T		6D16, 16-E	
Item							
Model	Hole-type (1-spring)	Hole-type (1-spring)	Hole-type (2-spring)	Hole-type (1-spring)		Hole-type (1-spring)	
No. of holes	5	5		5		5	
Hole diameter (mm)	0.28	0.29	0.315	0.29	0.31	0.31	0.29
Manufacturer	DENSO	BOSCH AUTOMOTIVE SYSTEMS	DENSO	BOSCH AUTOMOTIVE SYSTEMS		BOSCH AUTOMOTIVE SYSTEMS	

Engine model	6D16-T, 16-TE		6D16-TL	6D16-TLE	
Item					
Model	Hole-type (1-spring)	Hole-type (2-spring)	Hole-type (1-spring)	Hole-type (1-spring)	
No. of holes	5		5	5	
Hole diameter (mm)	0.31		0.31	0.29	0.275
Manufacturer	BOSCH AUTOMOTIVE SYSTEMS		BOSCH AUTOMOTIVE SYSTEMS	BOSCH AUTOMOTIVE SYSTEMS	

## Other Items

Item	Specifications
Fuel filter type	Spin-on type (paper filter)
Secondary fuel filter type	Filter paper type
Water separator type	Sediment trap type

# STRUCTURE AND OPERATION

## 1. Fuel System

For electronic fuel system, refer to Gr. 13E.

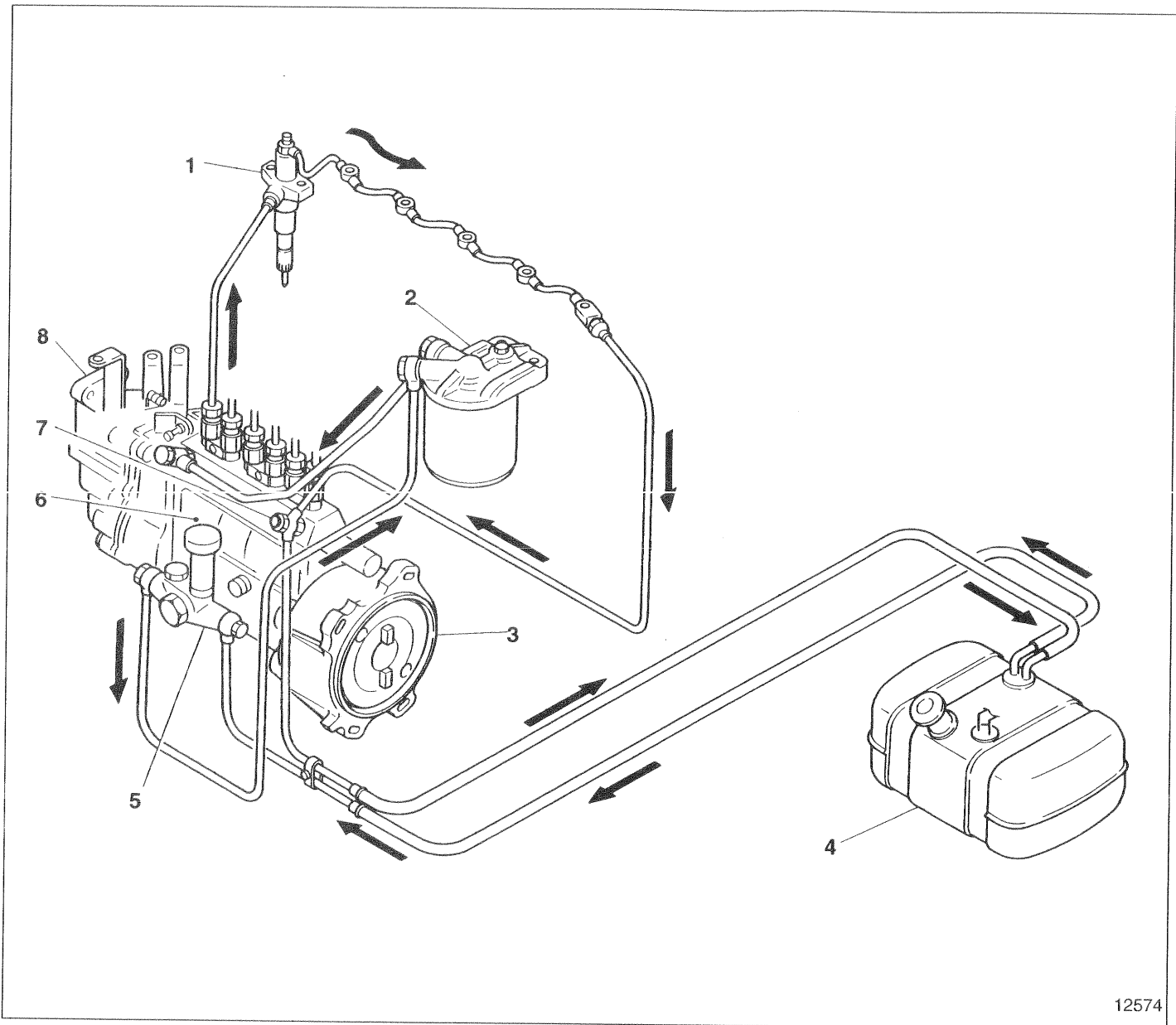

12574

- |                    |                  |
|--------------------|------------------|
| 1 Injection nozzle | 5 Feed pump      |
| 2 Fuel filter      | 6 Injection pump |
| 3 Automatic timer  | 7 Overflow valve |
| 4 Fuel tank        | 8 Governor       |

- Fuel from the fuel tank 4 is drawn up by the feed pump 5 and strained by the fuel filter 2. The feed pump is driven by a cam in the injection pump 6.
- After filtration, fuel is fed to the injection pump 6. From there, it is fed under high pressure to the injection nozzles 1. The injection nozzles spray the fuel into the combustion chambers.
- If the fuel pressure in the injection pump 6 exceeds a preset level, the overflow valve 7 opens to allow excess fuel to return to the fuel tank 4.

## 2. Fuel Filter

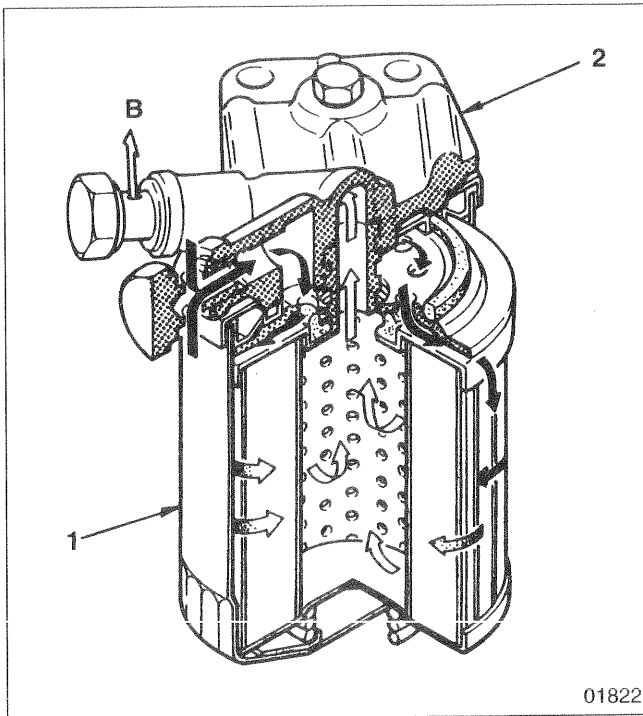

- 1 Fuel filter
  - 2 Fuel filter head
- A: From feed pump  
B: To injection pump

The fuel filter separates any water content out of fuel fed from the injection pump's feed pump, and its element removes any impurities.

## 3. Secondary Fuel Filter

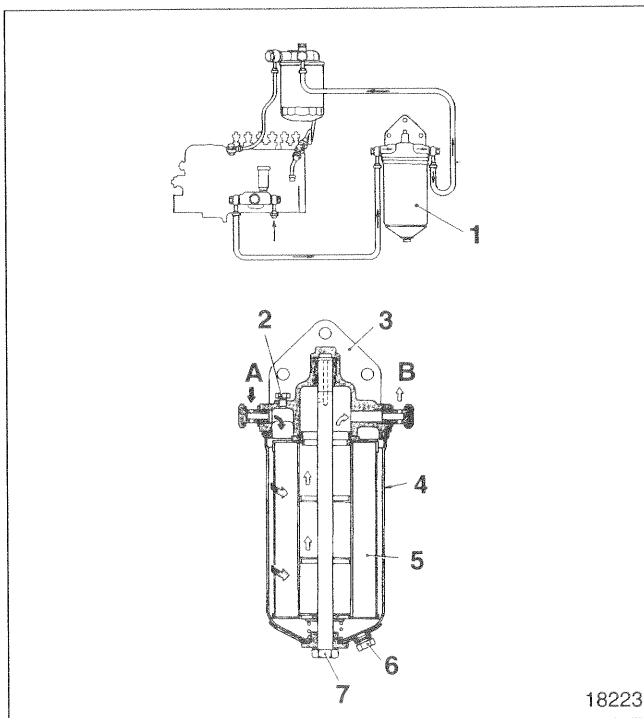

- 1 Secondary fuel filter
  - 2 Air plug
  - 3 Cover
  - 4 Case
  - 5 Element
  - 6 Drain plug
  - 7 Center bolt
- A: From feed pump  
B: To fuel filter

When the engine is run on JIS class 1 heavy oil (ASTM No. 4; BS class D, B1 and B2), a secondary fuel filter is fitted in the position illustrated. Like the regular fuel filter, this unit separates any water content out of fuel received from the feed pump. It uses a paper element to remove impurities.

# STRUCTURE AND OPERATION

## 4. Water Separator

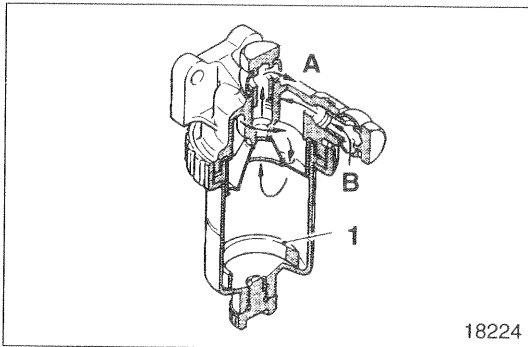

1 Water level ring

A: Fuel outlet (to feed pump)

B: Fuel inlet

The sediment trap type water separator splits fuel and water centrifugally utilizing the difference in specific gravity between the two fluids. Fuel entering from the inlet connector is squeezed through a passage in the head, resulting in a faster flow with a more powerful axial twist. Water separated from the fuel settles in the case, and the water-free fuel flows to the feed pump via a passage in the center of the head.

The water separator is effective in removing not only water but also dirt and other impurities. A red water level ring 1 floats inside the case, enabling the water quantity to be checked at a glance.

## 5. Injection Pump

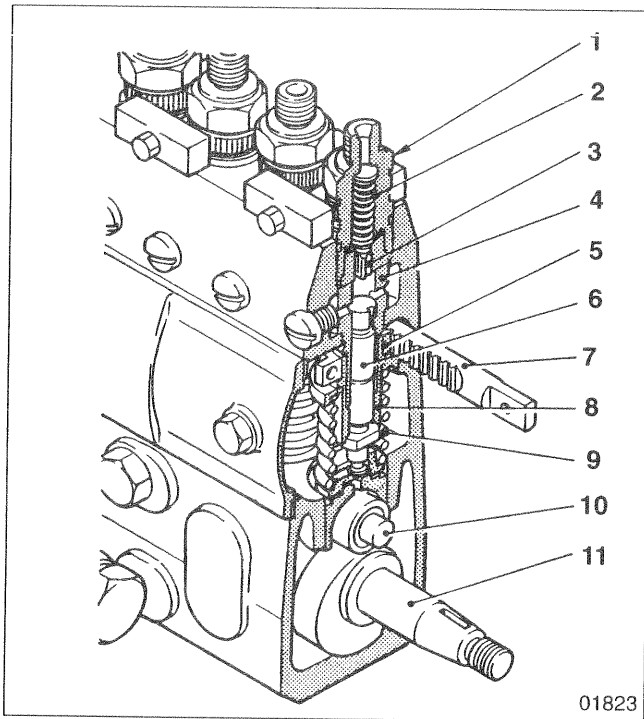

1 Delivery valve holder

2 Delivery valve spring

3 Delivery valve

4 Plunger barrel

5 Control pinion

6 Plunger

7 Control rack

8 Control sleeve

9 Plunger spring

10 Tappet

11 Camshaft

The injection pump feeds fuel to the injection nozzles under high pressure and incorporates a mechanism for increasing and decreasing the fuel flow.

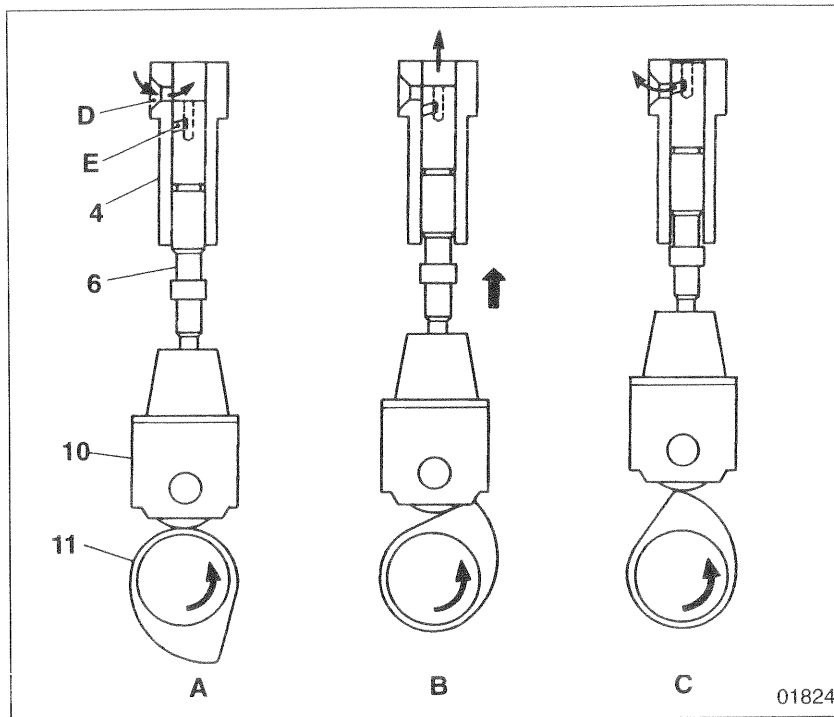

● Fuel feed action

- A: Fuel drawn in
- B: Start of pressure feed
- C: End of pressure feed
- D: Inlet/outlet hole
- E: Lead

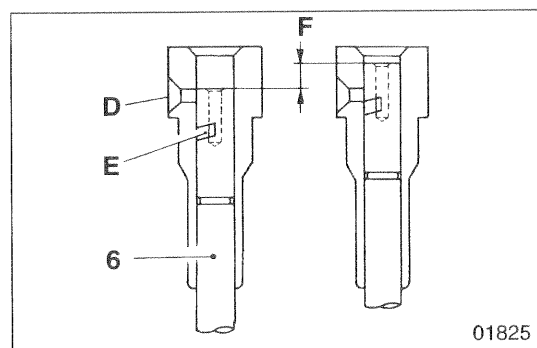

As the plunger 6 rises and its lead E meets the fuel inlet/outlet hole D, fuel flows through the center of the plunger and is expelled from the inlet/outlet hole. Regardless of how much further the plunger rises, no fuel feed takes place thereafter.

The stroke length F of the plunger 6 during which pressure feed takes place is known as the "effective stroke."

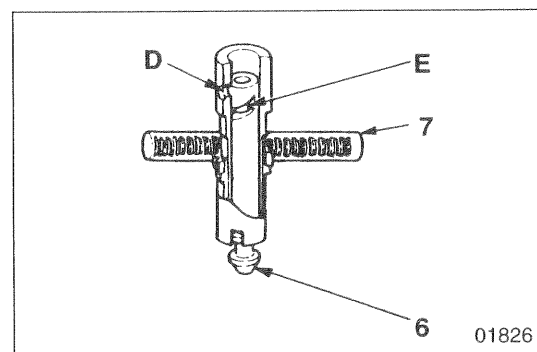

● Injection volume adjustment mechanism

To match changes in engine loading, an adjustment mechanism controls the amount of fuel injected. This mechanism turns the plunger 6 by a given angle, thereby altering the point at which the fuel inlet/outlet hole D meets the lead E. Simply stated, the effective stroke is made longer or shorter. A single control rack 7 is used to rotate every plunger in the engine, so the plungers rotate simultaneously and by the same angle.

# STRUCTURE AND OPERATION

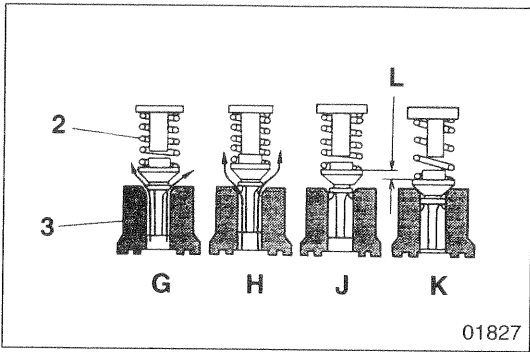

## ● Delivery valve

- G: Pressurization starts
- H: Injection
- J: Pressurization ends (Starting suction)
- K: Suction ends
- L: Suction stroke

Fuel highly pressurized by plunger pushes up delivery valve **3** for injection, and when delivery of pressurized fuel ends, delivery valve returns by the force of delivery valve spring to close fuel passage, thus avoiding reverse flow of fuel. Delivery valve lowers further to rest at its seat, and for this stroke **L**, residual pressure between delivery valve and injection nozzle is for an instant lowered. This return suction makes fuel-cutting at nozzles effective and avoids post-injection dripping.

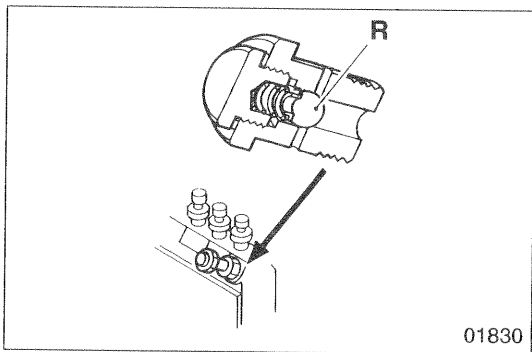

## ● Overflow valve

When the fuel pressure in the injection pump exceeds a preset level, the steel ball **R** is pushed up, allowing fuel to flow out from the injection pump and return to the fuel tank. This stabilizes the fuel temperature and temperature distribution in the injection pump and keeps the injection rate constant in each cylinder.

## 6. Governor

<RSV Type>

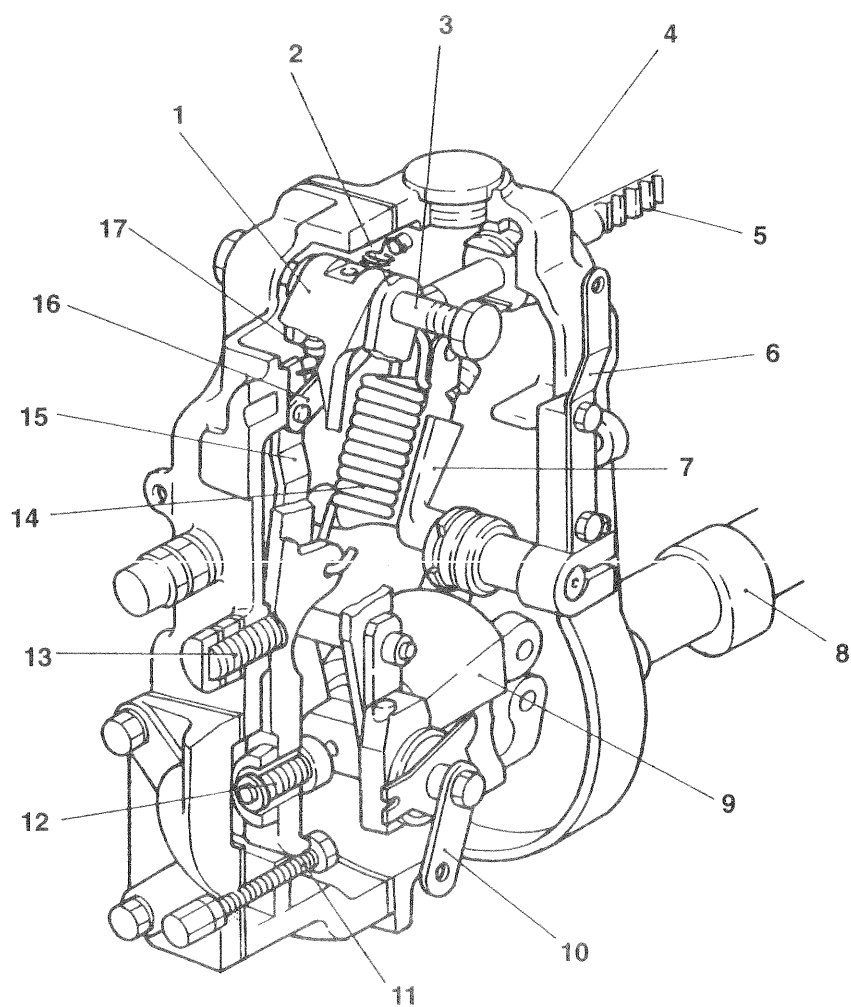

18225

- |                          |                                     |
|--------------------------|-------------------------------------|
| 1 Tension lever          | 10 Stop lever                       |
| 2 Guide lever            | 11 Full-load stopper bolt           |
| 3 Supporting lever shaft | 12 Ungleich spring or idling spring |
| 4 Governor housing       | 13 Idling subspring                 |
| 5 Control rack           | 14 Governor spring                  |
| 6 Adjusting lever        | 15 Control lever                    |
| 7 Swivel lever           | 16 Shackle                          |
| 8 Camshaft               | 17 Start spring                     |
| 9 Flyweight              |                                     |

# STRUCTURE AND OPERATION

<RFD Type>

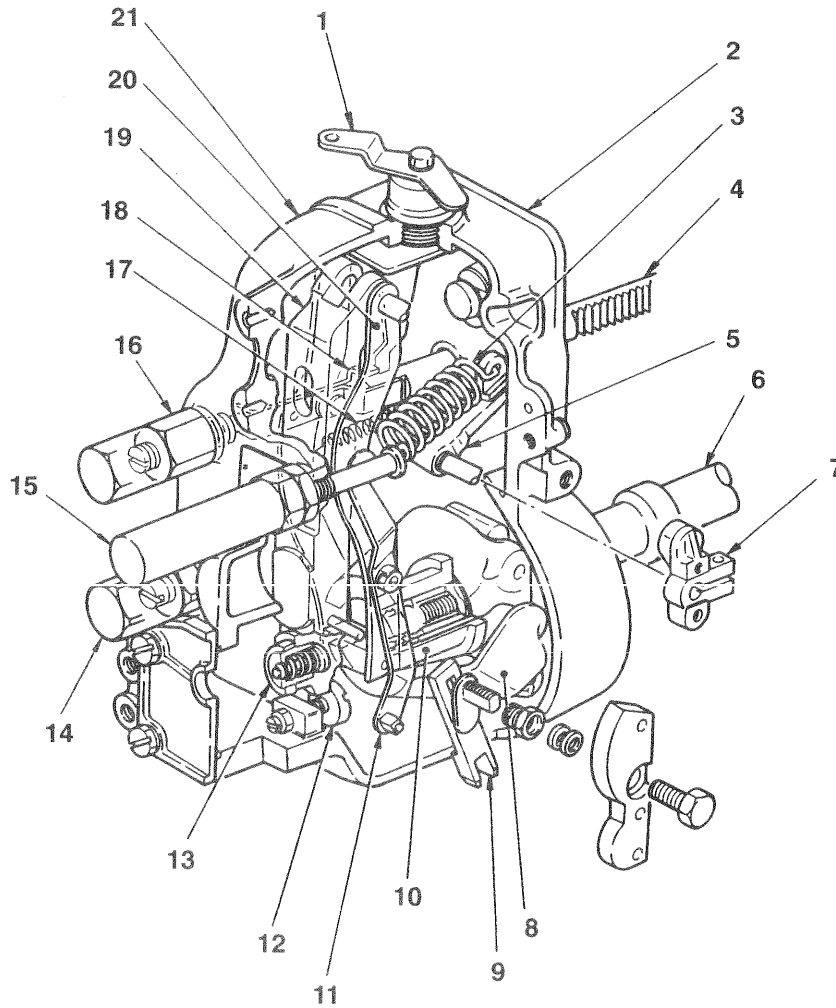

18227

- |                       |                          |
|-----------------------|--------------------------|
| 1 Stop lever          | 12 Stroke adjusting bolt |
| 2 Governor housing    | 13 Idling spring         |
| 3 Governor spring     | 14 Torque spring         |
| 4 Control rack        | 15 Smoke set assembly    |
| 5 Swivel lever        | 16 Damper spring         |
| 6 Camshaft            | 17 Start spring          |
| 7 Speed control lever | 18 Floating lever link   |
| 8 Flyweight           | 19 Tension lever         |
| 9 Sliding lever       | 20 Guide lever           |
| 10 Sleeve             | 21 Governor cover        |
| 11 Floating lever     |                          |

## 7. Feed Pump

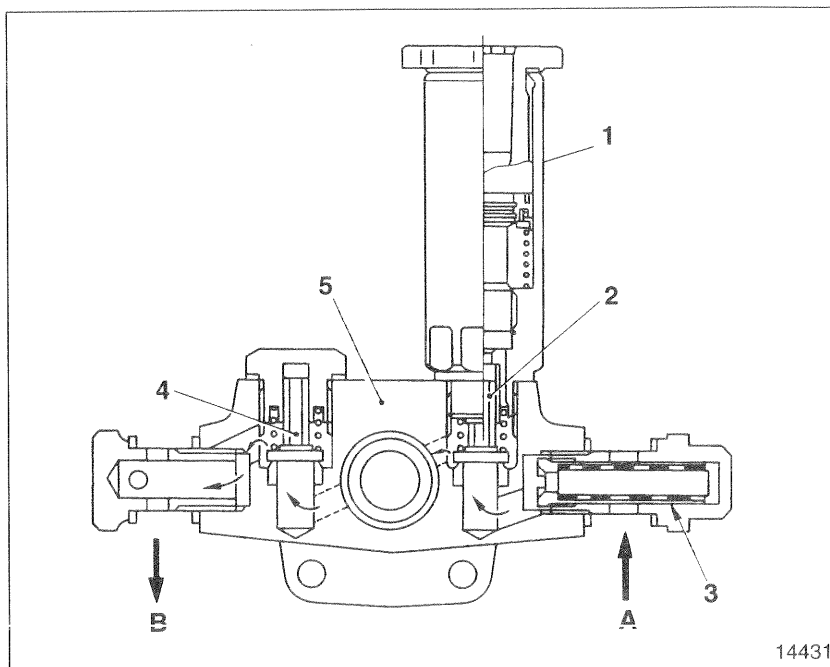

- 1 Priming pump
- 2 Inlet check valve
- 3 Gauze filter
- 4 Outlet check valve
- 5 Feed pump housing

A: From fuel tank

B: To fuel filter

The feed pump is driven by the camshaft in the injection pump. The priming pump 1 enables fuel to be drawn up manually when the injection pump is stationary. It is particularly useful for air bleeding.

The gauze filter 3 removes large impurities from fuel drawn up from the fuel tank and thus prevents clogging of the feed pump. It must be washed regularly in gas oil.

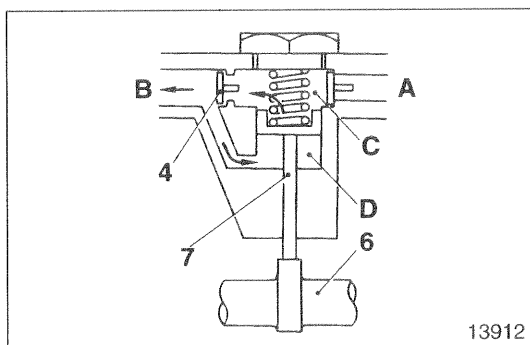

### ● Suction stroke

When the injection pump camshaft 6 forces up the push rod 7, fuel in the suction chamber C is compressed and opens the outlet check valve 4. Most of the fuel forced out is drawn into the pressure chamber D below the piston.

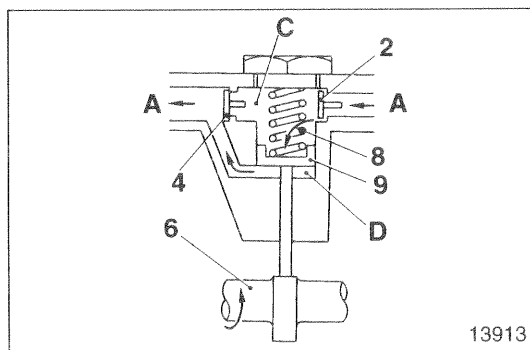

### ● Pressure feed stroke

As the camshaft 6 turns and the cam loses its lift, the piston 9 is pushed down by the piston spring 8. The fuel in the pressure chamber D is thus forced out and fed toward the fuel filter.

At the same time, the outlet check valve 4 closes and the inlet check valve 2 opens. As a result, fuel is again drawn into the suction chamber C.

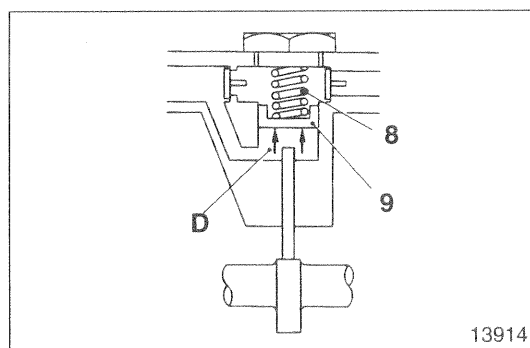

### ● Stoppage

When pressure in the pressure chamber D exceeds a preset level, the piston spring 8 cannot push back the piston 9. The pump therefore stops operating, preventing pressure in the fuel filter from rising more than necessary.

# STRUCTURE AND OPERATION

## 8. Automatic Timer

The automatic timer utilizes a mechanical arrangement to adjust the injection timing in accordance with the engine speed. The automatic timer is mounted on the injection pump camshaft using a round nut. Via a driving disk, it is driven by the air compressor crankshaft or pump drive shaft.

<SA-type automatic timer>

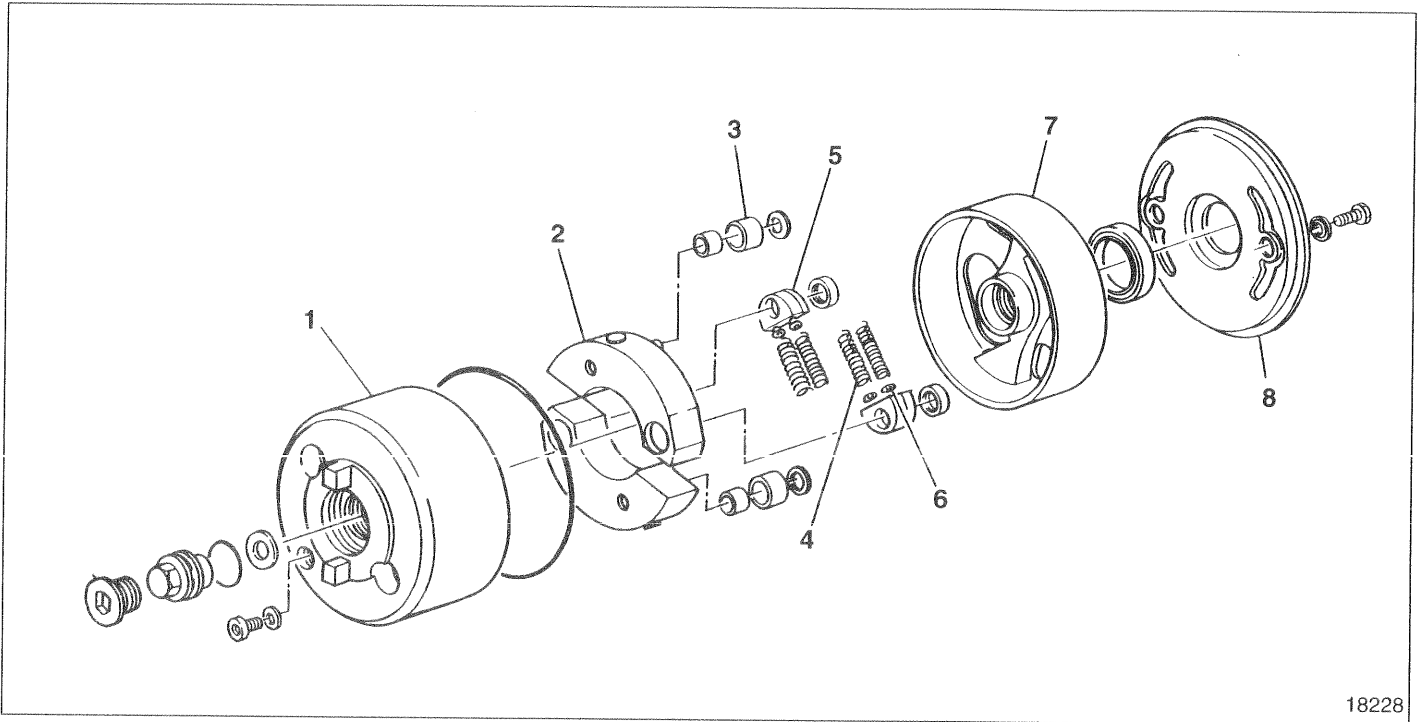

- 1 Timer housing
- 2 Flyweight
- 3 Roller
- 4 Timer spring

- 5 Spring seat
- 6 Shim
- 7 Flange
- 8 Cover

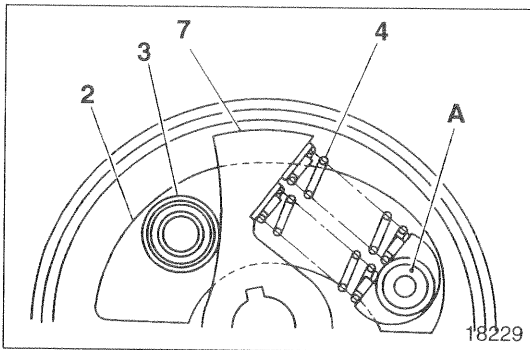

### ● With engine stationary

When the engine is stationary, the timer spring 4 overcomes the centrifugal force acting on the flyweight 2. The flyweight roller is therefore held down by the flange 7, and the injection timing arrangement is not advanced.

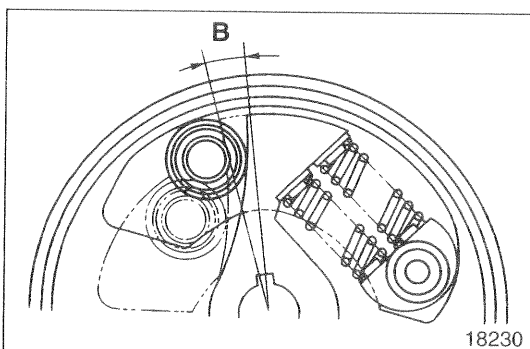

### ● With engine running

As the engine speed rises, the centrifugal force on the flyweight 2 increases. With the timer housing pin A as the fulcrum, the flyweight roller 3 thus moves outward while pushing the curved surface of the flange 7, causing the flange to compress the timer springs 4. As a result, the roller 3 of the flyweight 2 moves the flange 7 in the rotating direction and the injection timing is advanced.

<SPG-type automatic timer>

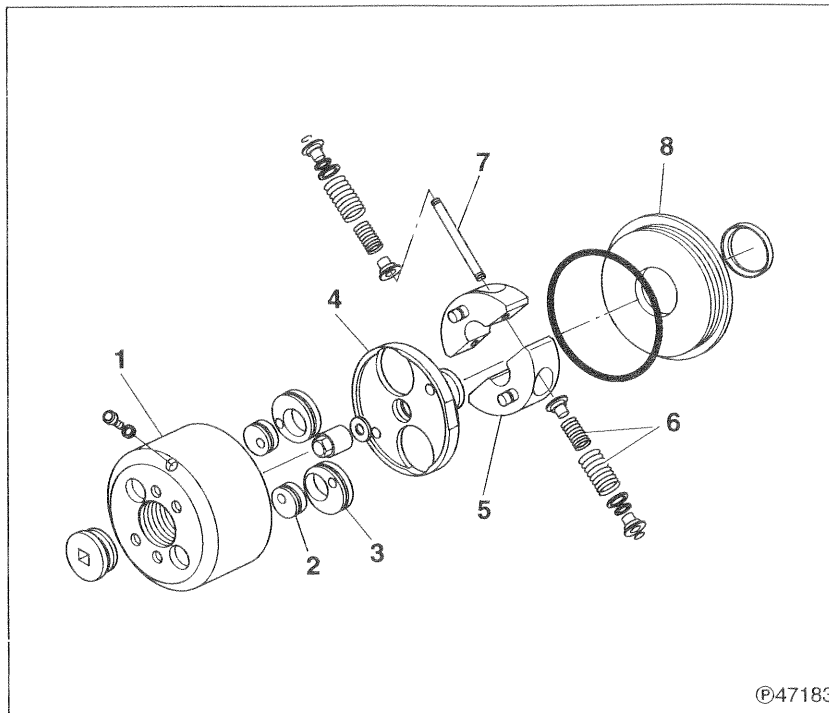

- 1 Timer housing
- 2 Eccentric cam (small)
- 3 Eccentric cam (large)
- 4 Timer holder
- 5 Flyweight
- 6 Timer spring
- 7 Pilot pin
- 8 Cover

©47183

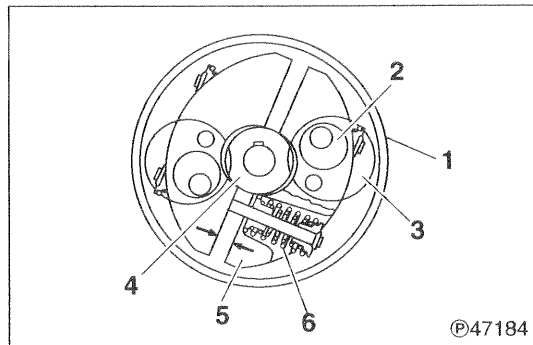

● With engine stationary

With the engine stationary, flyweight 5 is held against timer holder 4 by the force of timer spring 6.

©47184

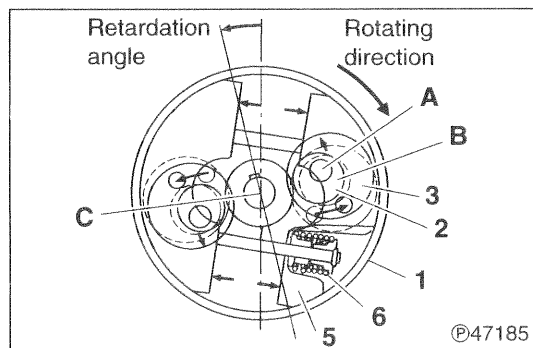

● With engine running

As the engine speed increases, the centrifugal force exerted on flyweight 5 matches the force of timer spring 6. As the engine speed increases further, the centrifugal force overcomes the force of spring, causing the flyweight to move outwards. As the flyweight moves outwards, eccentric cam (small) 2 rotates in the reverse direction of the shaft rotation about pin A of the timer housing. Also, center B of eccentric cam (large) 3 rotates in the reverse direction of the shaft rotation about center C of the timer. The eccentric cam (large) has been fit into timer holder 4. Therefore, the movement of the eccentric cam (large) is transmitted to the timer holder. The maximum retard is achieved when the back of the flyweight bottoms against the inner surface of timer housing 1.

©47185

# STRUCTURE AND OPERATION

## 9. Boost Compensator

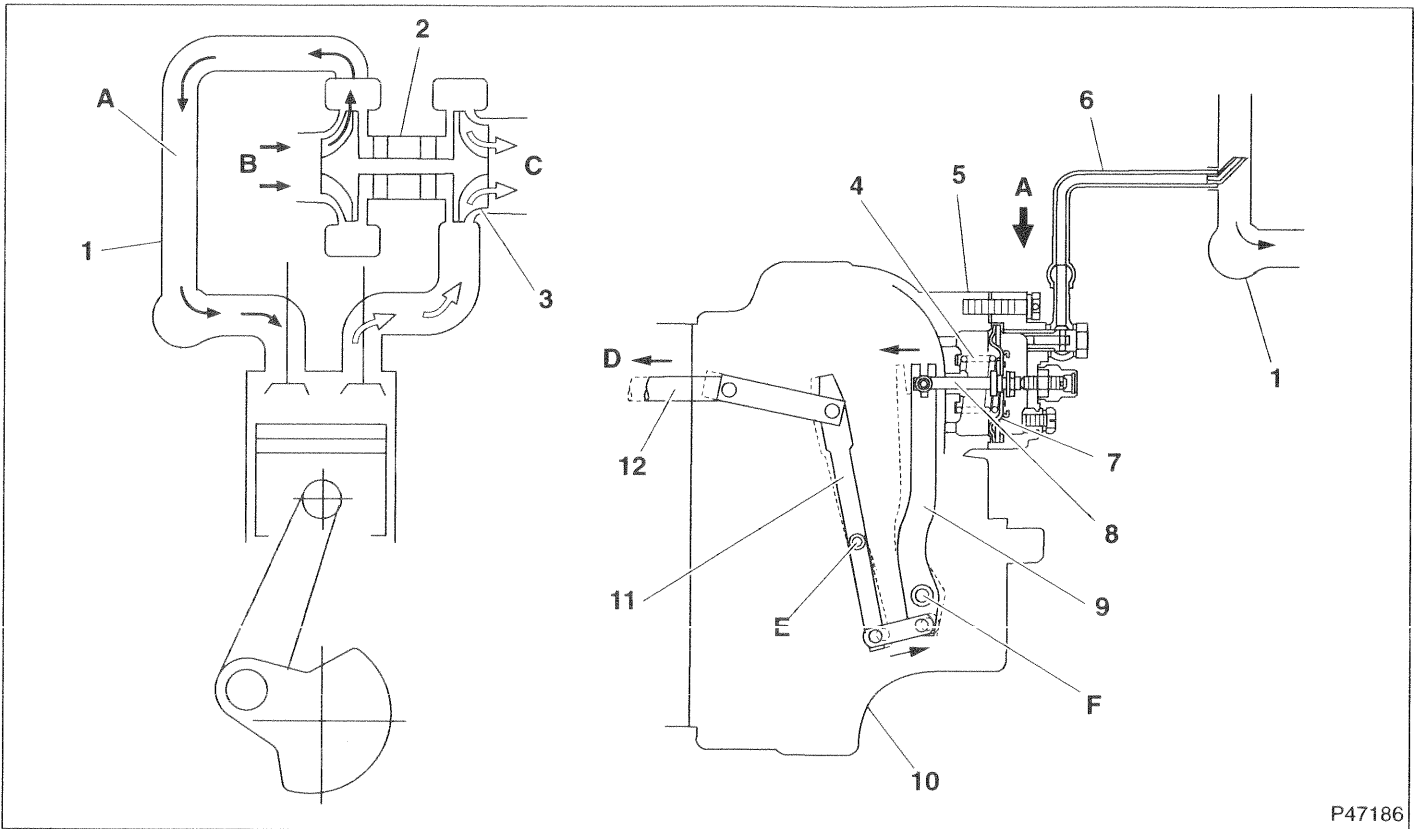

P47186

- |                            |                     |                   |
|----------------------------|---------------------|-------------------|
| 1 Inlet manifold           | 7 Diaphragm         | A: Boost pressure |
| 2 Turbo charger            | 8 Push rod          | B: Intake air     |
| 3 Turbine                  | 9 Compensator lever | C: Exhaust        |
| 4 Boost compensator spring | 10 Governor         | D: More fuel      |
| 5 Boost compensator        | 11 Floating lever   | E, F: Pivot       |
| 6 Hose                     | 12 Control rod      |                   |

- The boost compensator is designed to ensure that a greater amount of fuel is injected as the turbo charger feeds more air into the engine so that the engine output increases accordingly.
- As boost pressure **A** in inlet manifold **1** overcomes the force of boost compensator spring **4** of boost compensator **5**, diaphragm **7** and push rod **8** are pushed to the left.
- As push rod **8** is pushed to the left, compensator lever **9** moves counterclockwise about pivot **F** to the position shown by the dotted line. This causes floating lever **11** to move counterclockwise about pivot **E**, which in turn moves control rod **12** in the direction of **D** (more fuel). As a result, a greater amount of fuel is injected irrespective of the operations of governor **10**.

### 10. Injection Pump Drive

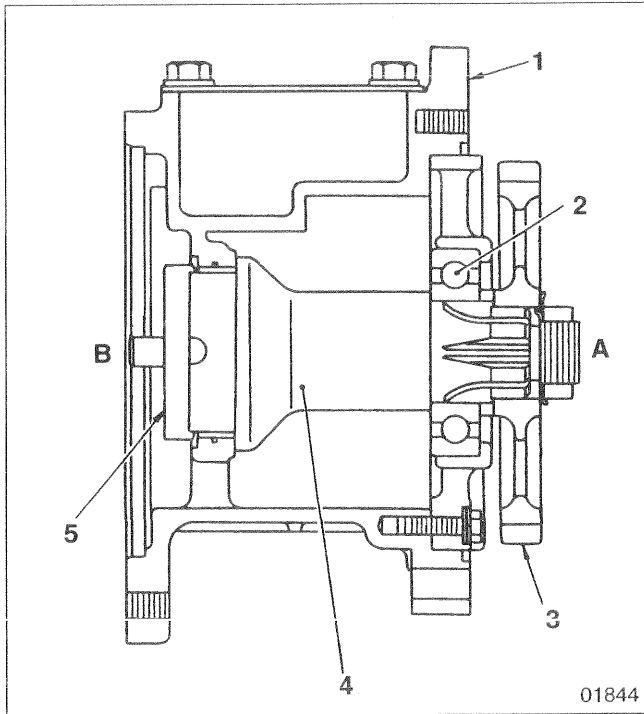

- 1 Pump drive case
- 2 Bearing
- 3 Pump drive gear
- 4 Pump drive shaft
- 5 Coupling

A: Timing gear side  
 B: Timer side

The injection pump drive is fitted onto the flywheel housing on the left of the engine. It is driven by the engine timing gear at half the engine speed.

The pump drive shaft 4 drives the injection pump via the coupling 5 on its timer side.

### 11. Injection Nozzle

<1-spring type>

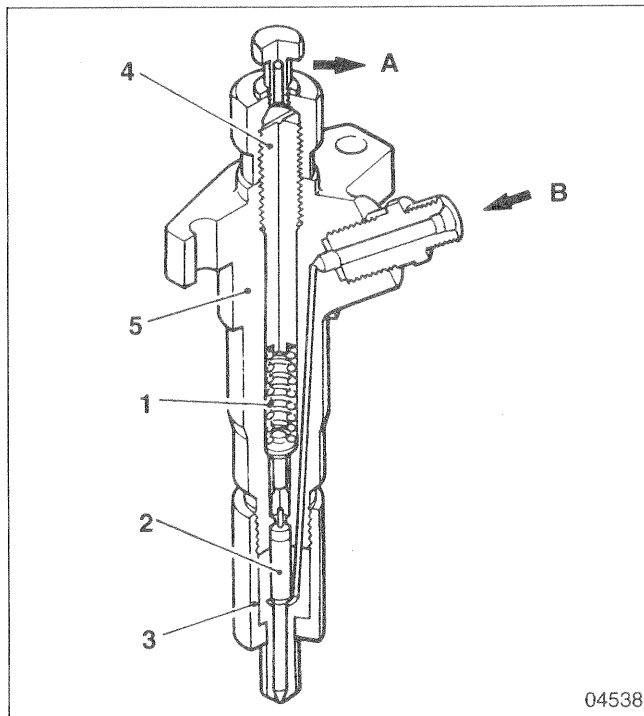

- 1 Nozzle spring
- 2 Needle valve
- 3 Nozzle
- 4 Adjusting screw
- 5 Nozzle holder

A: To leak-off pipe  
 B: From injection pump

Fuel fed from the injection pump enters the nozzle holder 5. When the fuel pressure in the nozzle holder exceeds a preset pressure, it overcomes the nozzle spring 1, pushes up the needle valve 2, and the fuel is sprayed into the cylinder from the orifice at the end of the nozzle 3.

Some of the high-pressure fuel lubricates the needle valve 2 and returns to the fuel tank via the leak-off pipe.

# STRUCTURE AND OPERATION

<2-spring type>

<BOSCH AUTOMOTIVE SYSTEMS>

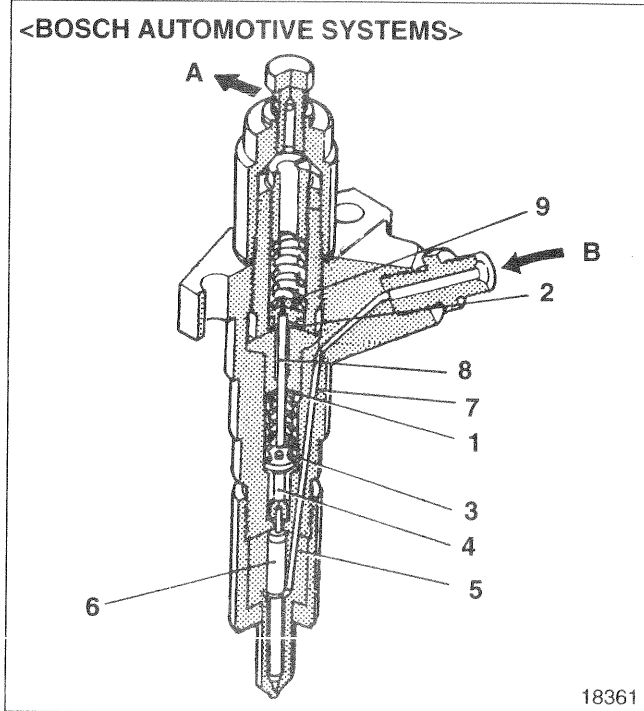

- 1 Valve opening pressure adjustment shim
- 2 Prelift adjustment shim
- 3 1st spring
- 4 1st push rod
- 5 Nozzle
- 6 Needle valve
- 7 Nozzle holder
- 8 2nd push rod
- 9 2nd spring

Inside the nozzle, there are two springs **3, 9** and two push rods **4, 8**. A prelift clearance is provided between the two push rods. When high-pressure fuel from the injection pump overcomes the 1st spring **3** (this spring determines the valve opening pressure), the needle valve **6** pushes up the 1st push rod **4**, thereby opening the valve.

When the 1st push rod **4** moves through the prelift clearance and contacts the 2nd push rod **8**, the needle valve **6** momentarily stops lifting. As the fuel pressure increases further and overcomes the combined force of the 1st spring **3** and 2nd spring **9**, the needle valve **6** lifts again for the main injection.

<DENSO>

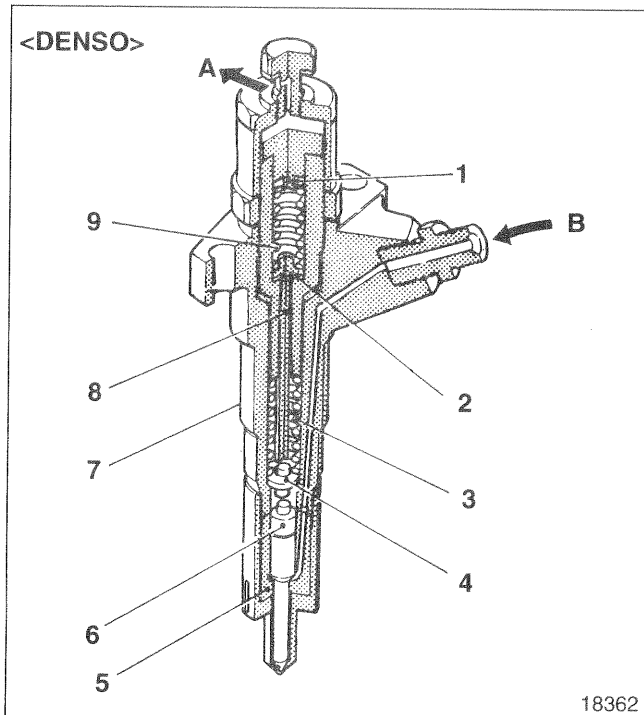

---

**M E M O**







---

# TROUBLESHOOTING

Possible causes		Symptoms																
		Engine will not start	Engine difficult to start	Engine knocks	Unstable engine output	Insufficient engine output	Engine maximum speed too high	Unstable engine idling	Engine stops soon after starting	Engine does not reach maximum speed	Engine will not stop	Accelerator pedal too stiff	Defective fuel supply					
Injection pump proper	Sticky plunger	<input type="radio"/>																
	Sticky control rack	<input type="radio"/>																
	Sticky delivery valve	<input type="radio"/>																
	Worn tappet	<input type="radio"/>																
	Worn camshaft	<input type="radio"/>																
	Poorly adjusted injection timing		<input type="radio"/>		<input type="radio"/>	<input type="radio"/>		<input type="radio"/>										
	Worn plunger					<input type="radio"/>		<input type="radio"/>										
	Defective delivery valve seat					<input type="radio"/>												
	Excessively advanced injection timing			<input type="radio"/>														
	Insufficient plunger slide stroke				<input type="radio"/>													
	Broken plunger spring				<input type="radio"/>						<input type="radio"/>							
	Defective sliding action in control rack		<input type="radio"/>		<input type="radio"/>			<input type="radio"/>	<input type="radio"/>									
	Tappet worn or not sliding correctly				<input type="radio"/>													
	Broken delivery valve spring				<input type="radio"/>	<input type="radio"/>												
	Poor airtightness due to loose delivery valve holder				<input type="radio"/>	<input type="radio"/>												
	Defective delivery valve operation				<input type="radio"/>													
	Loose control pinion									<input type="radio"/>								
	Plunger spring not seating correctly									<input type="radio"/>								
	Delivery valve holder too tight									<input type="radio"/>								
Uneven injection volume to cylinders		<input type="radio"/>							<input type="radio"/>	<input type="radio"/>								
Fuel feed pump	Gauze filter clogged	<input type="radio"/>							<input type="radio"/>	<input type="radio"/>								
	Check valve not operating	<input type="radio"/>																
	Sticky piston	<input type="radio"/>																
	Sticky push rod	<input type="radio"/>																
	Worn tappet	<input type="radio"/>																
	Defective check valve operation		<input type="radio"/>		<input type="radio"/>					<input type="radio"/>								
	Piston worn		<input type="radio"/>		<input type="radio"/>					<input type="radio"/>								

Possible causes		Symptoms											
		Engine will not start	Engine difficult to start	Engine knocks	Unstable engine output	Insufficient engine output	Engine maximum speed too high	Unstable engine idling	Engine stops soon after starting	Engine does not reach maximum speed	Engine will not stop	Accelerator pedal too stiff	Defective fuel supply
Governor	Insufficient full-load stopper position					<input type="radio"/>							
	Weak governor spring					<input type="radio"/>				<input type="radio"/>			
	Incorrectly adjusted control lever				<input type="radio"/>	<input type="radio"/>				<input type="radio"/>			
	Flyweights not operating effectively						<input type="radio"/>						
	Weak idling spring							<input type="radio"/>					
	Bent links							<input type="radio"/>	<input type="radio"/>				
	Excessive friction or play in links							<input type="radio"/>	<input type="radio"/>				
	Loose round nut							<input type="radio"/>	<input type="radio"/>				
	Poorly adjusted idling set bolt							<input type="radio"/>	<input type="radio"/>				
	Defective sliding action in control lever											<input type="radio"/>	
	Stop mechanism damaged										<input type="radio"/>		
Automatic timer	Defective advancing action					<input type="radio"/>		<input type="radio"/>					
Injection nozzles	Sticky needle valve	<input type="radio"/>											
	Valve opening pressure too low	<input type="radio"/>								<input type="radio"/>			
	Blocked injection orifice	<input type="radio"/>		<input type="radio"/>		<input type="radio"/>		<input type="radio"/>		<input type="radio"/>			
	Poor airtightness in nozzle	<input type="radio"/>		<input type="radio"/>		<input type="radio"/>		<input type="radio"/>		<input type="radio"/>			
	Valve opening pressure too high			<input type="radio"/>									
	Broken spring				<input type="radio"/>	<input type="radio"/>							
	Defective sliding action in needle valve				<input type="radio"/>								
	Defective valve opening pressure				<input type="radio"/>								
Fuel filter	Weakness/deterioration in spring							<input type="radio"/>					
	Filter (and/or secondary filter) clogged	<input type="radio"/>			<input type="radio"/>			<input type="radio"/>	<input type="radio"/>				
Fuel tank empty		<input type="radio"/>											
Fuel pipes blocked and/or fuel leaking from connections		<input type="radio"/>											
Air or water in fuel system		<input type="radio"/>			<input type="radio"/>			<input type="radio"/>	<input type="radio"/>				
Low-quality fuel in use			<input type="radio"/>	<input type="radio"/>		<input type="radio"/>		<input type="radio"/>					
Cracked fuel pipe													<input type="radio"/>
Leaky fuel tank													<input type="radio"/>
Incorrect oil viscosity	📖 Gr. 12	<input type="radio"/>											
Incorrect valve clearance	📖 Gr. 11	<input type="radio"/>						<input type="radio"/>					
Defective head gasket	📖 Gr. 11	<input type="radio"/>						<input type="radio"/>					
Wear and/or carbon deposits on valve and valve seat	📖 Gr. 11	<input type="radio"/>						<input type="radio"/>					
Weakness/deterioration in valve spring	📖 Gr. 11	<input type="radio"/>						<input type="radio"/>					

# TROUBLESHOOTING

Possible causes	Symptoms	Engine will not start	Engine difficult to start	Engine knocks	Unstable engine output	Insufficient engine output	Engine maximum speed too high	Unstable engine idling	Engine stops soon after starting	Engine does not reach maximum speed	Engine will not stop	Accelerator pedal too stiff	Defective fuel supply
		Worn/damaged piston ring(s)  Gr. 11		<input type="checkbox"/>	<input type="checkbox"/>					<input type="checkbox"/>			
Worn/damaged piston ring groove(s)  Gr. 11		<input type="checkbox"/>	<input type="checkbox"/>					<input type="checkbox"/>					
Worn piston and cylinder liner  Gr. 11		<input type="checkbox"/>	<input type="checkbox"/>					<input type="checkbox"/>					
Cooling system malfunctioning  Gr. 14		<input type="checkbox"/>	<input type="checkbox"/>					<input type="checkbox"/>					
Defective starter switch  Gr. 54		<input type="checkbox"/>	<input type="checkbox"/>										
Defective glow relay  Gr. 54		<input type="checkbox"/>	<input type="checkbox"/>										

---

**M E M O**

---

# ON-VEHICLE INSPECTION AND ADJUSTMENT

## 1. Checking and Adjusting Injection Timing

<Except 6D16-TLE>

### Service standards

Location	Maintenance item	Standard value	Limit	Remedy
—	Fuel injection timing (BTDC)	Depends on specifications	—	Adjust

### ⓘ Tightening torques

Unit: N · m {kgf · m}

Location	Parts to be tightened	Tightening torque	Remarks
1	Union nut (injection pipe mounting)	25 {2.5}	—
2	Bolt (delivery valve holder lock plate)	DENSO	7.8 to 11 {0.8 to 1.1}
		BOSCH AUTOMOTIVE SYSTEMS <A-type>	4.4 to 6.0 {0.45 to 0.6}
		BOSCH AUTOMOTIVE SYSTEMS <AD-type>	3.4 to 4.9 {0.35 to 0.5}
3	Delivery valve holder	DENSO	34 to 39 {3.5 to 4}
		BOSCH AUTOMOTIVE SYSTEMS <A-type>	39 to 44 {4 to 4.5}
		BOSCH AUTOMOTIVE SYSTEMS <AD-type>	49 to 54 {5 to 5.5}

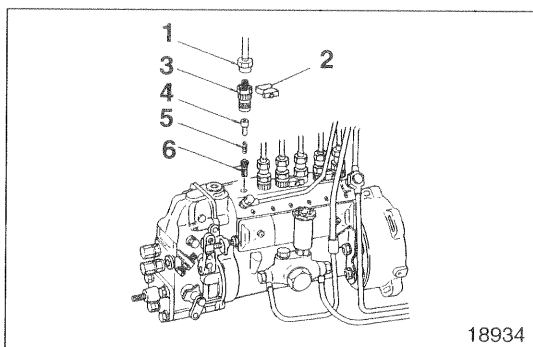

[Inspection]

- From the injection pump's No. 1 cylinder, remove the injection pipe 1, lock plate 2, delivery valve holder 3, stopper 4, delivery valve spring 5, and delivery valve 6.
- Fit the delivery valve holder 3.

**CAUTION** ⚠

Place all parts in gas oil after removal to keep them free of dust.

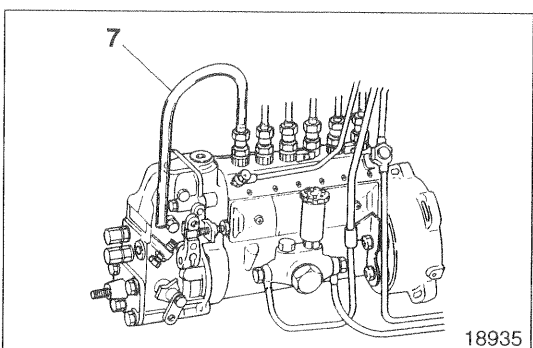

- Fit an injection pipe 7 onto cylinder No. 1. Point the pipe's other end downward such that fuel flowing out can be seen clearly.
- Rotate the crankshaft pulley clockwise (as seen from the front of engine) by at least 180° and bring cylinder No. 1 to approximately 30° BTDC on its compression stroke.

### NOTE

If the engine is turned in its reverse direction (when stopping the engine or by cranking), the automatic timer may stay in an advanced condition. This may not be cancelled by a slight forward rotation of the engine. Be sure to crank the engine forward manually by at least 180°.

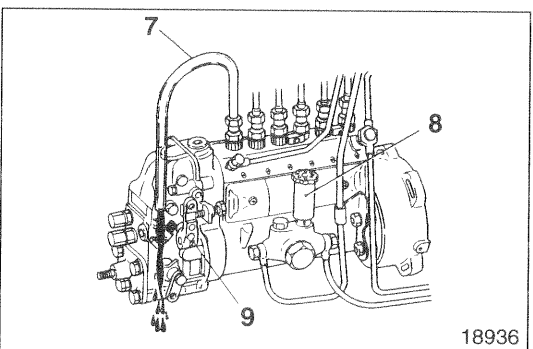

- Feed fuel into the injection pump using the priming pump 8. With fuel flowing out of the injection pipe 7, crank the engine slowly clockwise (as seen from the front of engine).

### NOTE

Ensure that the stop lever 9 at the side of the governor is not in its STOP position.

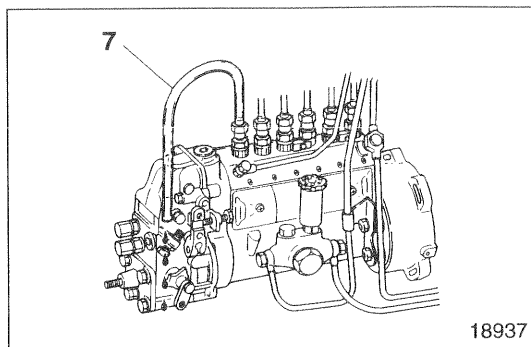

- When the flow of fuel from the injection pipe 7 diminishes, crank the engine more slowly. When the flow of fuel stops completely, stop cranking the engine.

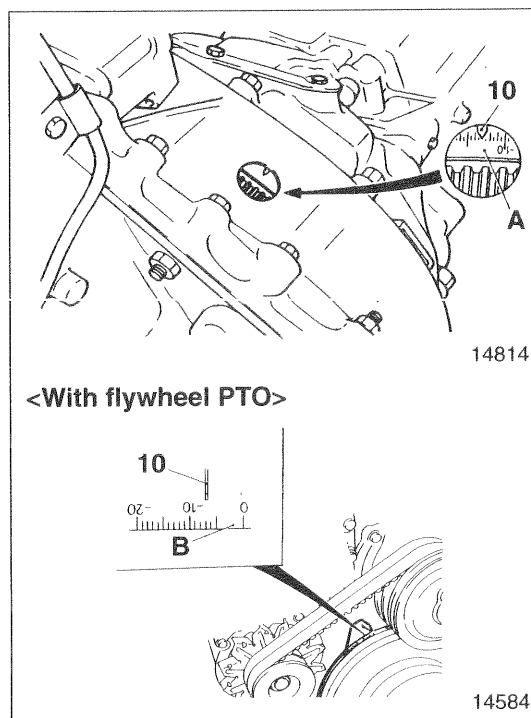

- Check that the pointer 10 on the flywheel housing or torsional damper B indicates the value 1° earlier than the correct fuel injection timing.  
A: Flywheel

#### NOTE

- The injection timing in this measurement becomes 1° earlier than the correct injection timing due to the inactivation of the delivery valve spring.
- The correct injection timing is indicated on the plate attached on the rocker cover.
- If the injection timing should be measured in a dusty location, perform as follows:
  - Rotate the crankshaft pulley clockwise (as seen from the front of engine) and bring the No. 1 cylinder to 30° BTDC on its compression stroke.
  - Disconnect the injection pipe 1 with a little amount of fuel remained at the top of the delivery valve holder 3.
  - Slowly rotate the crankshaft pulley clockwise. When the injection timing is reached, the fuel at the top of the delivery valve holder 3 starts to move.
- If the injection timing is out of the specification, adjust as follows:

#### [Adjustment]

- Loosen the nuts 12 that hold the timer case 11 onto the pump drive or air compressor 13.
- If the fuel injection timing is overly retarded, incline the injection pump toward the crankcase.
- If the fuel injection timing is overly advanced, incline the injection pump away from the crankcase.

#### NOTE

Turning the injection pump by one of the gradations inscribed on the timer case flange C causes a 6° change in the injection timing.

- Tighten the nuts 12, then check the fuel injection timing again.

#### NOTE

If the fuel injection timing is so far out of specification that adjustment with the injection pump is not possible, the engine timing gear and injection pump drive gear may not be meshing correctly. If this occurs, remove and refit the air compressor or injection pump drive.

- Air compressor: Gr. 61
- Injection pump drive: P.13A-40
- After checking that the fuel injection timing is up to specification, fit the delivery valve 6, delivery valve spring 5, and stopper 4.

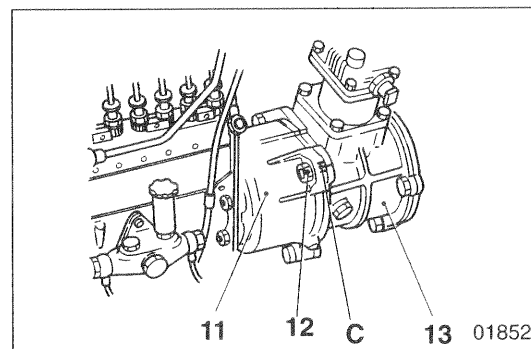

# ON-VEHICLE INSPECTION AND ADJUSTMENT

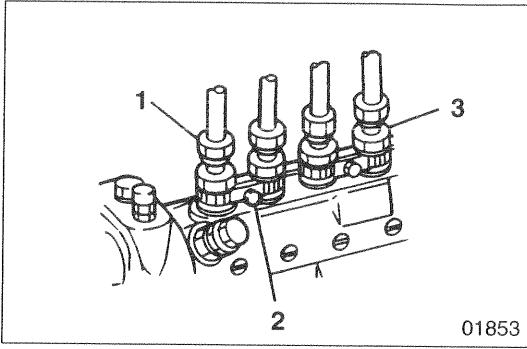

- Tighten each part to its specified torque.

## <6D16-TLE>

### Service standards

Location	Maintenance item	Standard value	Limit	Remedy
—	Fuel injection timing (BTDC)	Depends on specifications	—	Adjust

### Tightening torques

Unit: N · m {kgf · m}

Location	Parts to be tightened	Tightening torque	Remarks
2	Bolt	59 to 64 {6 to 6.5}	—

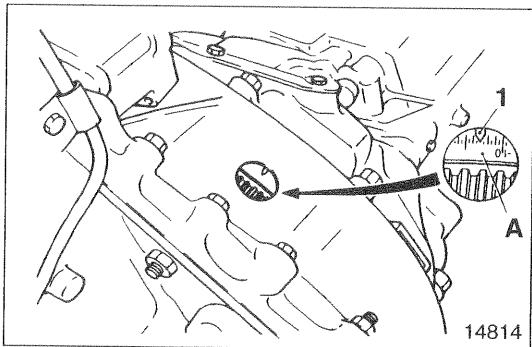

#### [Inspection]

- Turn the crankshaft by 180° or more in the forward direction to bring cylinder No. 1 to TDC on its compression stroke. Set the injection timing by aligning the specified value shown on scale **A** stamped on the periphery of the flywheel with pointer **1** on the flywheel housing.

#### CAUTION

If the engine is turned in reverse while the engine is stationary, the automatic timer can move to an advanced position. To return the automatic timer to a normal position, it may be necessary to manually rotate the engine forward by 180° or more.

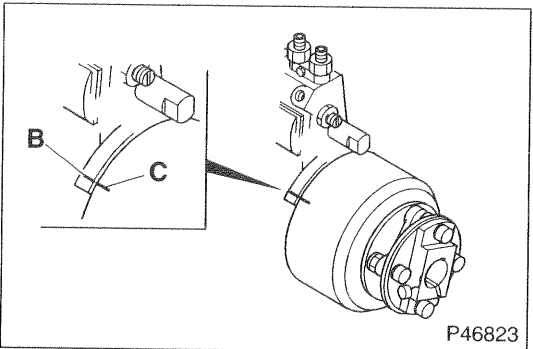

- The injection timing is correct if line **B** inscribed in the injection pump aligns with line **C** inscribed in the automatic timer.
- If out of alignment, adjust using the following procedures.

#### [Adjustment]

- Loosen adjusting bolt **2**. Turn the automatic timer to align line **B** with line **C**.
- Tighten adjusting bolt **2** to the specified torque.
- Repeat the injection timing inspection.

#### CAUTION

Only adjusting bolt **2** should be loosened.

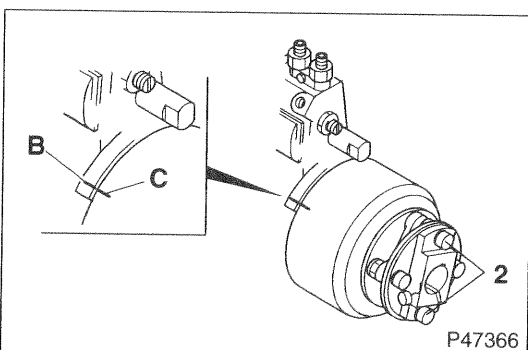

## 2. Checking and Adjusting Minimum and Maximum No-load Speeds

### Service standards

Location	Maintenance item	Standard value	Limit	Remedy
—	No-load minimum speed	Depends on specifications	—	Adjust
—	No-load maximum speed	Depends on specifications	—	Adjust

Start the engine and allow it to warm up before carrying out the following inspections.

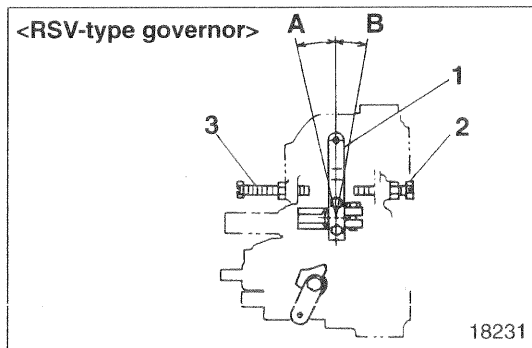

#### ● No-load minimum speed

[Inspection]

Confirm that the control lever 1 is touching the idling set bolt 3. Then check that the minimum speed is up to specification.

A : Idling position

[Adjustment]

If the minimum speed is out of specification, adjust it using the idling set bolt 3.

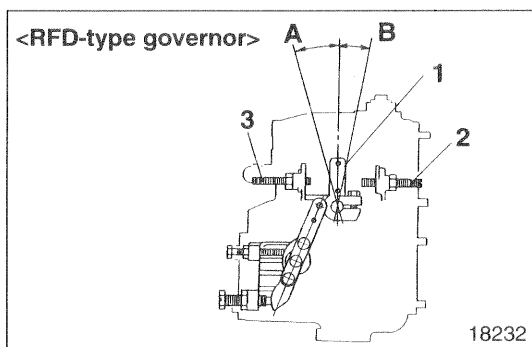

#### ● No-load maximum speed

[Inspection]

Confirm that the control lever 1 is touching the full-speed set bolt 2. Then, check that the maximum speed is up to specification.

B : Full-speed position

[Adjustment]

If the maximum speed is out of specification, adjust it using the full-speed set bolt 2.

#### NOTE

Check that the engine does not stall and that no hunting occurs when the control lever 1 is moved quickly from the full-speed position to the idling position. If any abnormality is apparent, make adjustments within the specified range.

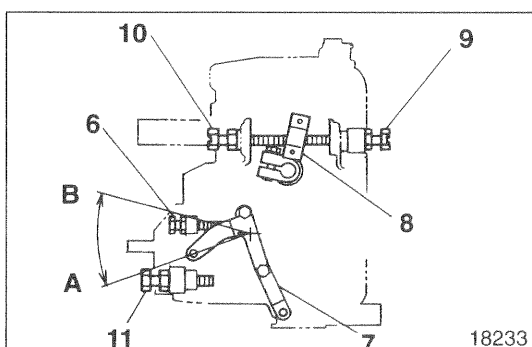

#### ● No-load minimum speed

[Inspection]

Confirm that the load control lever 7 is touching the idling set bolt 6. Then check that the minimum speed is up to specification.

A : Idling position

[Adjustment]

If the minimum speed is out of specification, adjust it using the idling set bolt 6.

# ON-VEHICLE INSPECTION AND ADJUSTMENT

## ● No-load maximum speed

[Inspection]

Move the load control lever **7** to the full-load position **B**. Then, check that the maximum speed is up to specification.

[Adjustment]

If the maximum speed is out of specification, adjust position of the speed control lever **8** using the maximum speed stopper bolt **9** and stopper bolt **10**.

## NOTE

- Do not alter the position of the full-load stopper bolt **11**.
- Check that the engine does not stall and that no hunting occurs when the load control lever **7** is moved quickly from the full-load position to the idling position. If any abnormality is apparent, make adjustments within the specified range.

## 3. Cleaning Fuel Feed Pump Gauze Filter

### ① Tightening torques

Unit: N·m {kgf·m}

Location	Parts to be tightened	Tightening torque	Remarks
1	Eyebolt	BOSCH AUTOMOTIVE SYSTEMS	20 to 25 {2 to 2.5}
		DENSO	15 to 20 {1.5 to 2}

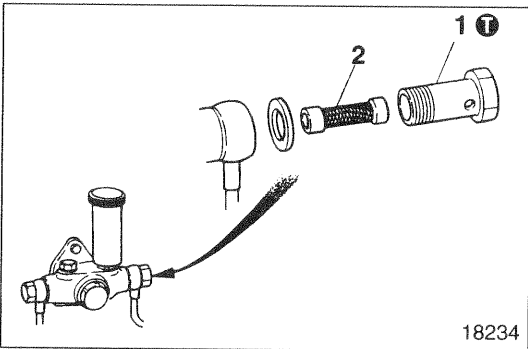

- Remove the eyebolt **1** from the suction port side of the fuel feed pump.
- Remove the gauze filter **2** from the eyebolt **1**.
- Clean the gauze filter **2**.
- Refit the gauze filter **2** and eyebolt **1** in the opposite order to their removal.
- Bleed all air out of the fuel system.
- Start the engine and check for fuel leaks.

---

**MEMO**

---

# FUEL FILTER

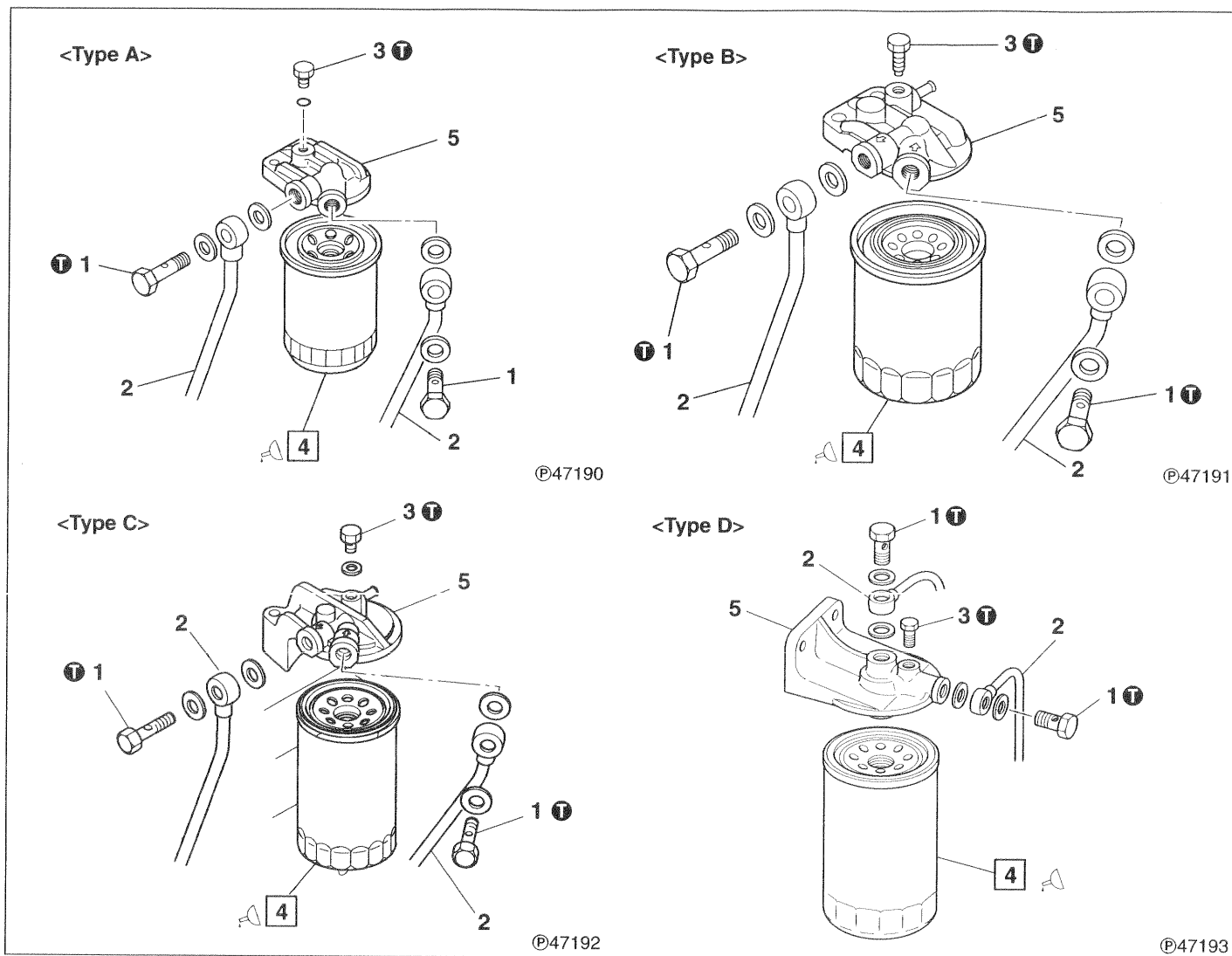

## ● Disassembly sequence

- 1 Eyebolt
- 2 Fuel pipe
- 3 Air vent plug
- 4 Fuel filter
- 5 Fuel filter head

## ● Assembly sequence

Reverse the order of disassembly.

## ⓘ Tightening torques

Unit: N · m {kgf · m}

Location	Parts to be tightened	Tightening torque	Remarks
1	Eyebolt	34 {3.5}	—
3	Air vent plug	9.8 ± 2.0 {1 ± 0.2}	—

## 🔧 Lubricant

Location	Points of application	Specified lubricant	Quantity
4	Gasket between fuel filter and fuel filter head	Engine oil	As required

**Special tools**

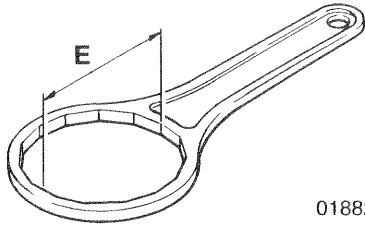
Location	Tool name and shape	Part No.	Application									
4	Filter Wrench		Removing fuel filter									
	<table border="1"> <thead> <tr> <th>Part No.</th> <th>E</th> <th>Filter model</th> </tr> </thead> <tbody> <tr> <td>MH061509</td> <td>90.2</td> <td>A, B</td> </tr> <tr> <td>MH061572</td> <td>94.2</td> <td>C, D</td> </tr> </tbody> </table>	Part No.		E	Filter model	MH061509	90.2	A, B	MH061572	94.2	C, D	MH061509 MH061572
	Part No.	E		Filter model								
MH061509	90.2	A, B										
MH061572	94.2	C, D										
	01882											

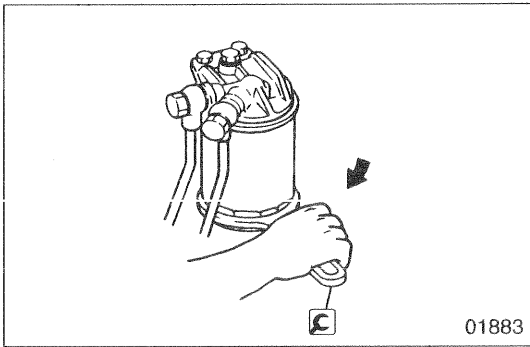

**Service procedure**

**4 Fuel filter**

[Removal]

**WARNING** ⚠

- Fuel is highly flammable; keep it away from flames and sources of heat.
- To minimize the risk of fire, wipe up any spilled fuel.

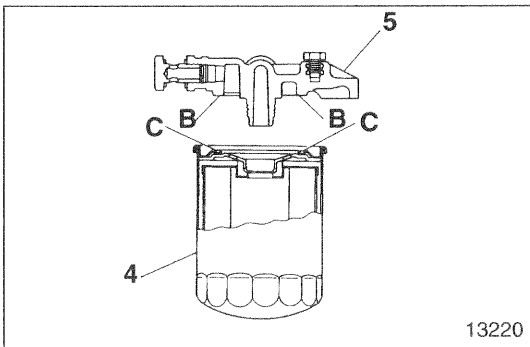

[Installation]

**WARNING** ⚠

Use of an unsuitable fuel filter 4 can lead to fuel leaks and fires. Be sure to use a genuine Mitsubishi filter.

- To fit the fuel filter 4, turn it until the gasket C touches surface B of the fuel filter head 5. Then, tighten the filter by 3/4 to 1 turn. Be sure to turn the filter by hand.
- Start the engine and check for fuel leaks.

# SECONDARY FUEL FILTER

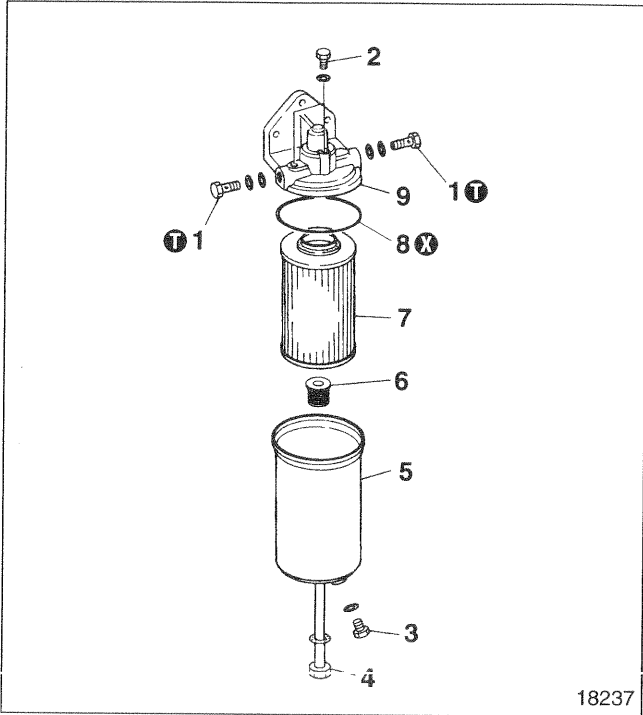

## ● Disassembly sequence

- 1 Eyebolt
- 2 Air vent plug
- 3 Drain plug
- 4 Center bolt
- 5 Case
- 6 Spring
- 7 Element
- 8 O-ring
- 9 Fuel filter head

ⓧ : Non-reusable part

## ● Assembly sequence

Reverse the order of disassembly.

## ⓧ Tightening torques

Unit: N · m {kgf · m}

Location	Parts to be tightened	Tightening torque	Remarks
1	Eyebolt	34 {3.5}	—

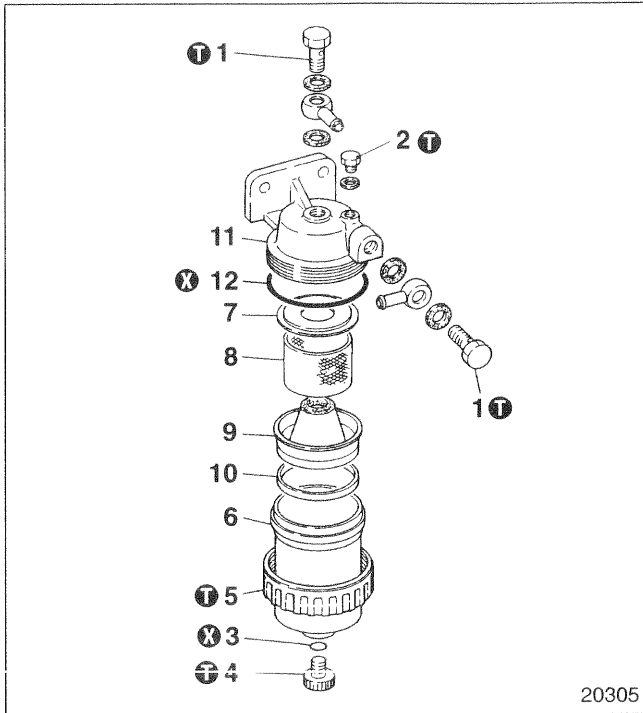

### ● Disassembly sequence

- 1 Eyebolt
- 2 Air vent plug
- 3 O-ring
- 4 Drain plug
- 5 Ring nut
- 6 Case
- 7 Isolation plate
- 8 Screen assembly
- 9 Baffle plate
- 10 Water level ring
- 11 Head
- 12 O-ring

⊗ : Non-reusable part

### WARNING

- Fuel ignites easily. Do not get it near flame or heat.
- Wipe up any spilled gas oil because it can cause a fire.

### ● Assembly sequence

Reverse the order of disassembly.

### ⓘ Tightening torques

Unit: N · m {kgf · m}

Location	Parts to be tightened	Tightening torque	Remarks
1	Eyebolt	34 {3.5}	—
2	Air vent plug	7.8 to 12 {0.8 to 1.2}	—
4	Drain plug	2.9 to 3.9 {0.3 to 0.4}	—
5	Ring nut	5.9 to 7.8 {0.6 to 0.8}	—

# INJECTION PUMP <Oldham's Coupling Type>

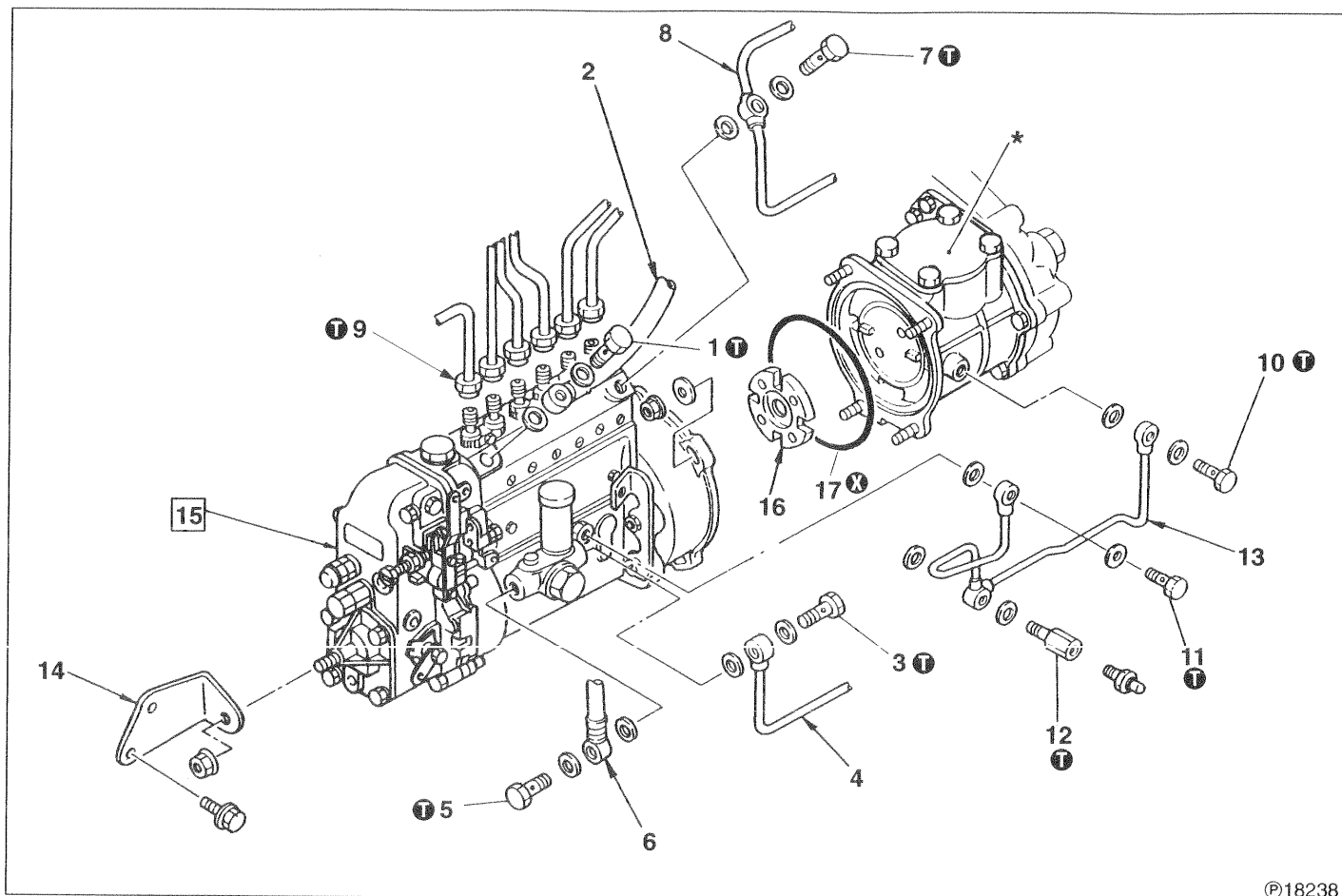

©18238

## ● Disassembly sequence

- |                     |                            |
|---------------------|----------------------------|
| 1 Eyebolt           | 9 Injection pipe           |
| 2 Fuel feed hose    | 10 Eyebolt                 |
| 3 Eyebolt           | 11 Eyebolt                 |
| 4 Fuel suction pipe | 12 Connector               |
| 5 Eyebolt           | 13 Oil pipe                |
| 6 Fuel feed hose    | 14 Injection pump stay     |
| 7 Eyebolt           | 15 Injection pump assembly |
| 8 Fuel return pipe  |                            |

- |                 |
|-----------------|
| 16 Driving disk |
| 17 O-ring       |

- \* : Injection pump drive  
 ⓘ P.13A-40,  
 or air compressor ⓘ Gr. 61  
 ⊗ : Non-reusable part

## ● Assembly sequence

Reverse the order of disassembly.

## WARNING ⚠

- Fuel is highly flammable; keep it away from flames and sources of heat.
- To minimize the risk of fire, wipe up any spilled fuel.

## CAUTION ⚠

Dirt particles in the injection pump assembly 15 can seriously detract from engine performance. To prevent the ingress of dirt, cover all pipes, hoses, and other parts after removal.

## NOTE

For maintenance of the injection pump assembly 15, please contact a BOSCH AUTOMOTIVE SYSTEMS service station or DENSO service station.

**① Tightening torques**

Unit: N·m {kgf·m}

Location	Parts to be tightened		Tightening torque	Remarks
1, 7	Eyebolt (fuel feed hose, fuel return pipe)	BOSCH AUTOMOTIVE SYSTEMS	20 to 29 {2 to 3}	—
		DENSO	15 to 20 {1.5 to 2}	—
3, 5	Eyebolt (fuel suction pipe, fuel feed hose)	BOSCH AUTOMOTIVE SYSTEMS	20 to 25 {2 to 2.5}	—
		DENSO	15 to 20 {1.5 to 2}	—
9	Injection pipe union nut		25 {2.5}	—
10	Eyebolt (oil pipe; air compressor or pump drive side)		21 {2.1}	—
11	Eyebolt (oil pipe; injection pump side)	BOSCH AUTOMOTIVE SYSTEMS	10 to 13 {1 to 1.3}	—
		DENSO	7.8 to 13 {0.8 to 1.3}	—
12	Connector (oil pipe)		21 {2.1}	—

**◆ Service procedure**

**15** Installing injection pump assembly

- Bring cylinder No. 1 of the engine to the TDC position of its compression stroke.

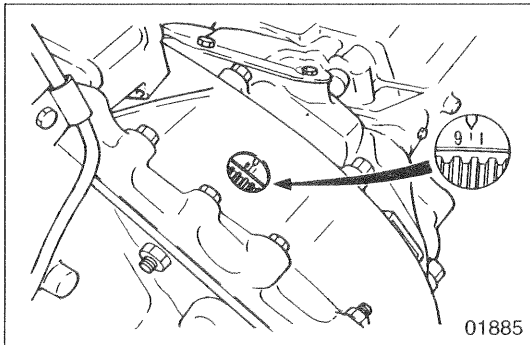

- Align the inscribed lines **C** on the timer case **A** and timer **B**. Then, fit the injection pump assembly **15** onto the air compressor or injection pump drive.

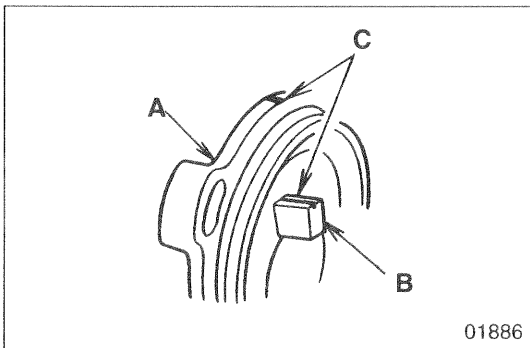

# INJECTION PUMP <Laminated Coupling Type>

## <Mechanical Governor>

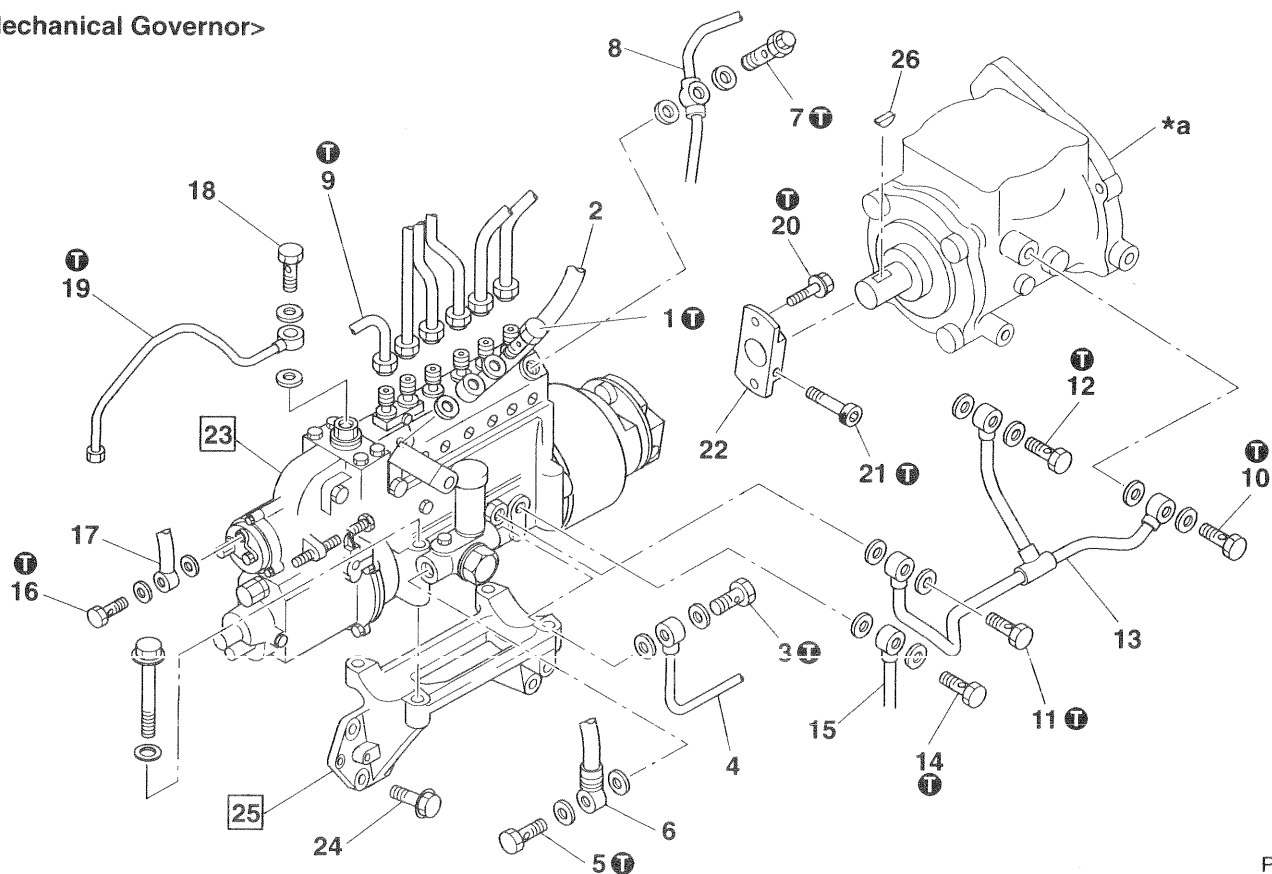

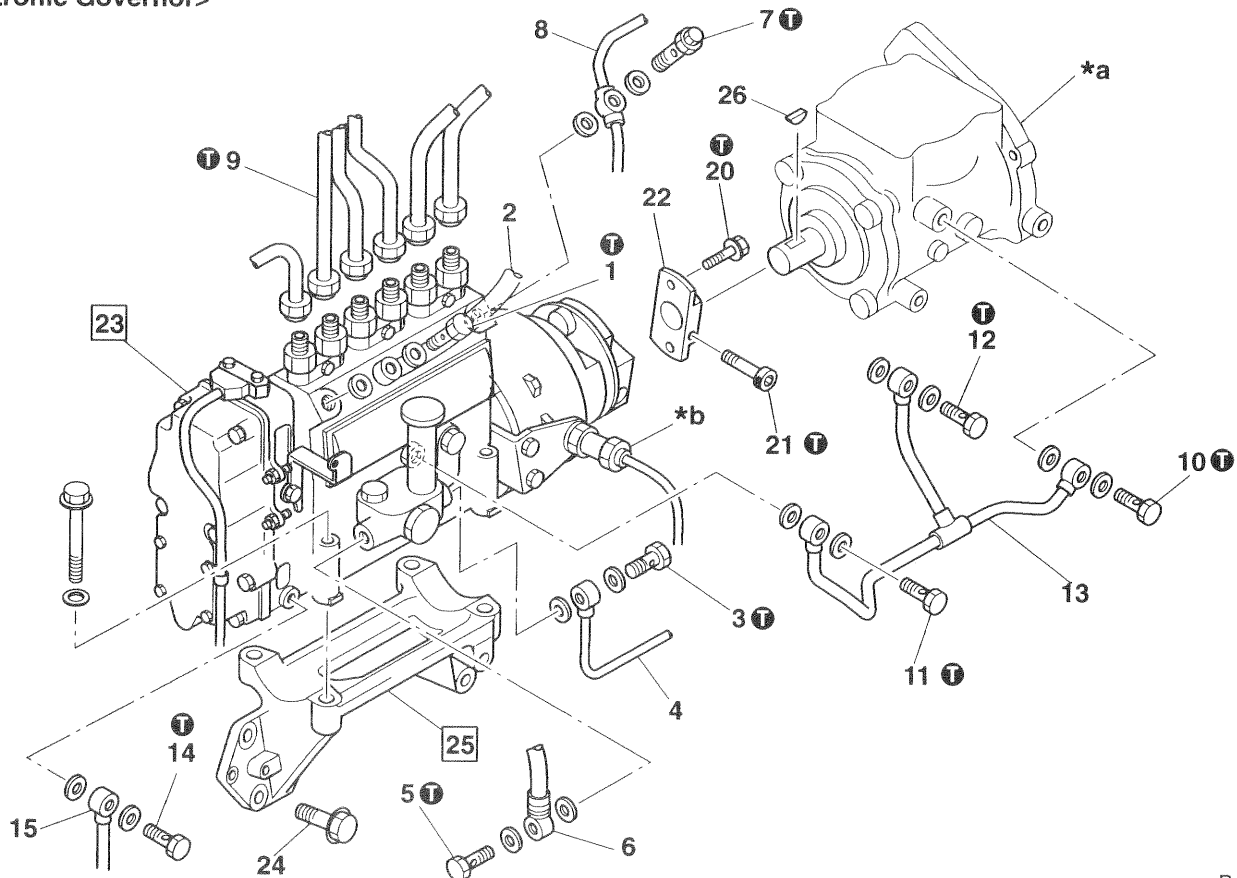

P46821

## <Electronic Governor>



P46822

### ● Disassembly sequence

- |                                   |   |
|-----------------------------------|---|
| 1 Eye bolt                        | 17 Boost hose (mechanical governor)   |
| 2 Fuel feed hose                  | 18 Eye bolt (mechanical governor)   |
| 3 Eye bolt                        | 19 Oil pipe (mechanical governor)   |
| 4 Fuel suction pipe               | 20 Bolt   |
| 5 Eye bolt                        | 21 Cotter bolt  |
| 6 Fuel feed hose                  | 22 Driving coupling   |
| 7 Eye bolt                        | 23 Injection pump assembly  |
| 8 Fuel return pipe                | 24 Bolt   |
| 9 Injection pipe                  | 25 Injection pump bracket   |
| 10 Eye bolt                       | 26 Key  |
| 11 Eye bolt                       |   |
| 12 Eye bolt                       |   |
| 13 Oil pipe                       | *a: Injection pump drive  P.13A-44 or air compressor |
| 14 Eye bolt                       |  Gr. 61  |
| 15 Oil return pipe                | *b: Engine speed sensor  Gr. 13E                     |
| 16 Eye bolt (mechanical governor) | ⊗: Non-reusable part  |

### ● Assembly sequence

Reverse the order of disassembly.

### CAUTION

- Fuel is highly flammable; keep it away from flames and sources of heat.
- To minimize the risk of fire, wipe up any spilled fuel.
- For maintenance of the injection pump assembly 23, please contact a Bosch Automotive Systems service station or Denso service station.
- Dirt particles in the injection pump assembly 23 can seriously detract from engine performance. To prevent the ingress of dirt, cover all pipes, hoses, and other parts after removal.
- Never carry around the injection pump assembly 23 by holding it at the lever or the engine speed sensor \*b. Removing the lever may result in deteriorated pump performance.
- Do not remove the injection pump bracket 25 unless it is faulty.

# INJECTION PUMP <Laminated Coupling Type>

## Service standards

Unit: mm

Location	Maintenance item	Standard value	Limit	Remedy
—	Fuel injection timing (BTDC)	Depends on specifications	—	Adjust
25	Injection pump bracket (eccentricity between injection pump centering tool and injection pump drive or air compressor crankshaft)	0.2	—	Adjust

## ① Tightening torques

Unit: N·m {kgf·m}

Location	Parts to be tightened	Tightening torque	Remarks
1, 7	Eye bolt (for fitting fuel feed hose and fuel return pipe)	20 to 29 {2 to 3}	—
3, 5	Eye bolt (for fitting fuel suction pipe and fuel feed hose)	20 to 25 {2 to 2.5}	—
9	Injection pipe (for fitting union nut)	25 {2.5}	—
10	Eye bolt (for fitting oil pipe on either injection pump drive or air compressor side)	20.6 {2.1}	—
11	Eye bolt (for fitting oil pipe on injection pump side)	10 to 13 {1 to 1.3}	—
12	Eye bolt (for fitting oil pipe on crankcase side)	20.6 {2.1}	—
14	Eye bolt (for fitting oil return pipe)	Mechanical governor	20 to 25 {2 to 2.5}
		Electronic governor	20 to 29 {2 to 3}
16	Eye bolt (for fitting boost hose)	10 to 13 {1 to 1.3}	—
19	Oil pipe	25 {2.6}	—
20	Bolt (for fitting driving coupling)	59 to 64 {6 to 6.5}	—
21	Cotter bolt	83 to 93 {8.5 to 9.5}	—

## ㊦ Special tools

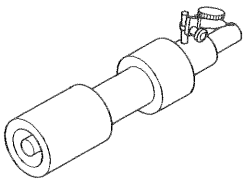
Location	Tool name and shape	Part No.	Application
25	Injection Pump Centering Tool  ©13221	MH063393	Locating injection pump bracket

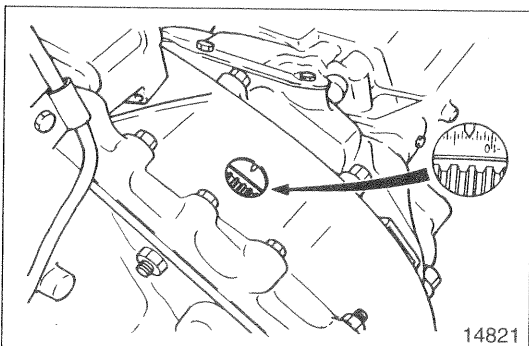

## ◆ Service procedure

### 23 Installing injection pump assembly

- Crank the engine to set cylinder No. 1 at the specified injection timing position.

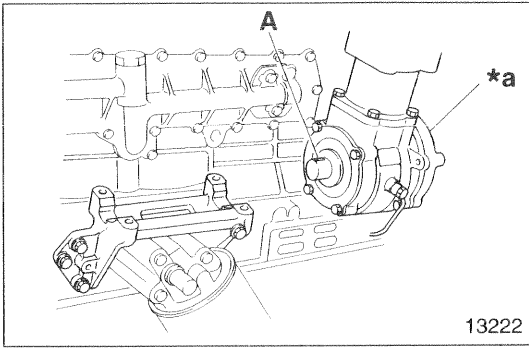

- Ensure that the key way **A** on the injection pump drive or air compressor (**\*a**) crankshaft is facing upwards.
- If key way **A** is not facing upwards, rotate the engine crankshaft by one turn.

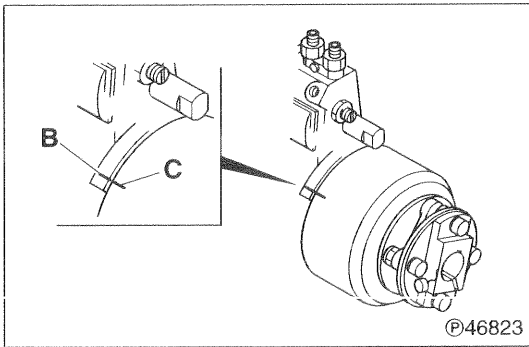

- Align line **B** inscribed on the injection pump and line **C** inscribed on the automatic timer.

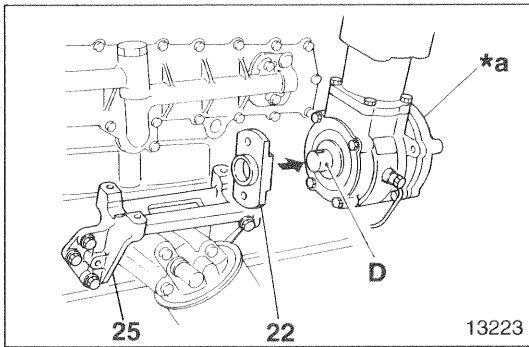

- Fit driving coupling **22** to the injection pump drive or air compressor **\*a** crankshaft **D**. Push the driving coupling against the injection pump drive or air compressor crankshaft **D**.
- Fit injection pump assembly **23** to injection pump bracket **25**.

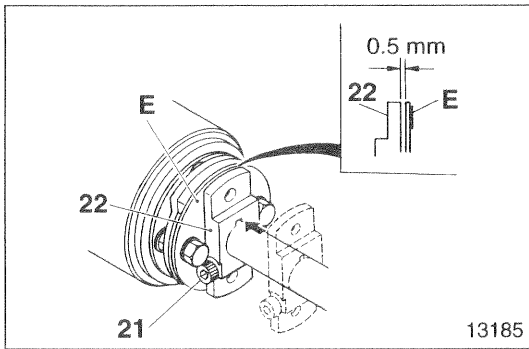

- Set driving coupling **22** apart from coupling plate **E** by 0.5 mm as shown in the illustration. Tighten cotter bolt **21** to the specified torque.

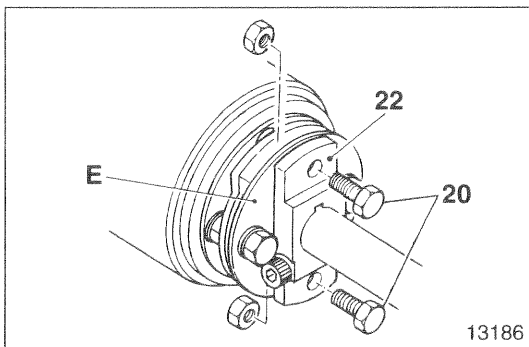

- Using bolts **20**, fit driving coupling **22** and coupling plate **E**.

# INJECTION PUMP <Laminated Coupling Type>

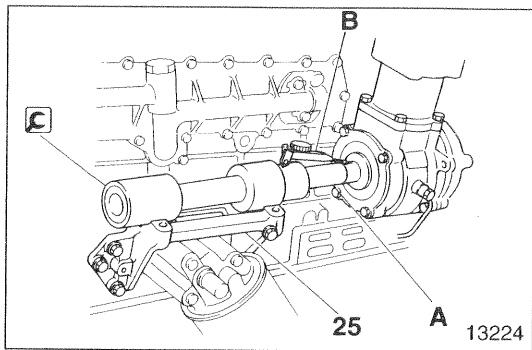

## 25 Injection pump bracket

[Inspection]

- Set dial gauge **B** at rod **A** of **C** Injection Pump Centering Tool for zero-point correction.

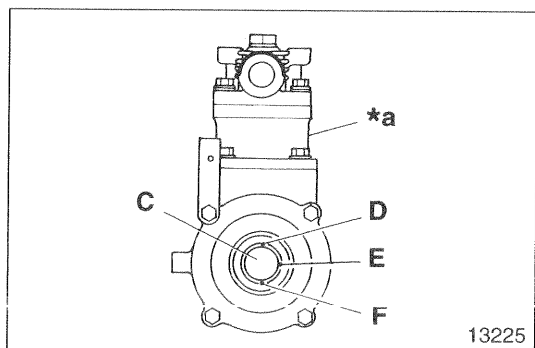

- Slide dial gauge **B** against the injection pump drive or the air compressor \*a and measure the eccentricity between rod **A** and the crankshaft **C** of the injection pump drive or the air compressor at **D**, **E** and **F**.
- If one of the measurements exceeds the specified value, adjust as follows.

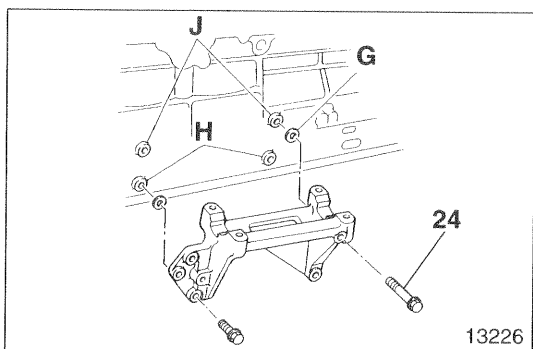

[Adjustment]

- When the measured value at point **E** is higher than the standard value: Insert shims **G** into four points equally.
- When the measured value at point **D** is higher than the standard value: Insert shims **G** into lower side **H**.
- When the measured value at point **F** is higher than the standard value: Insert shims **G** into upper side **J**.

## CAUTION

Insert shims **G** observing the following conditions:

- Number of shims per point is three or less.
- The same number of shims should be used for the front and the rear.
- The difference in number of shims used for bottom and top is none or one.

- Tighten bolts **24** to the specified torque and repeat the inspection.

---

**MEMO**

---

# INJECTION PUMP DRIVE <Oldham's Coupling Type>

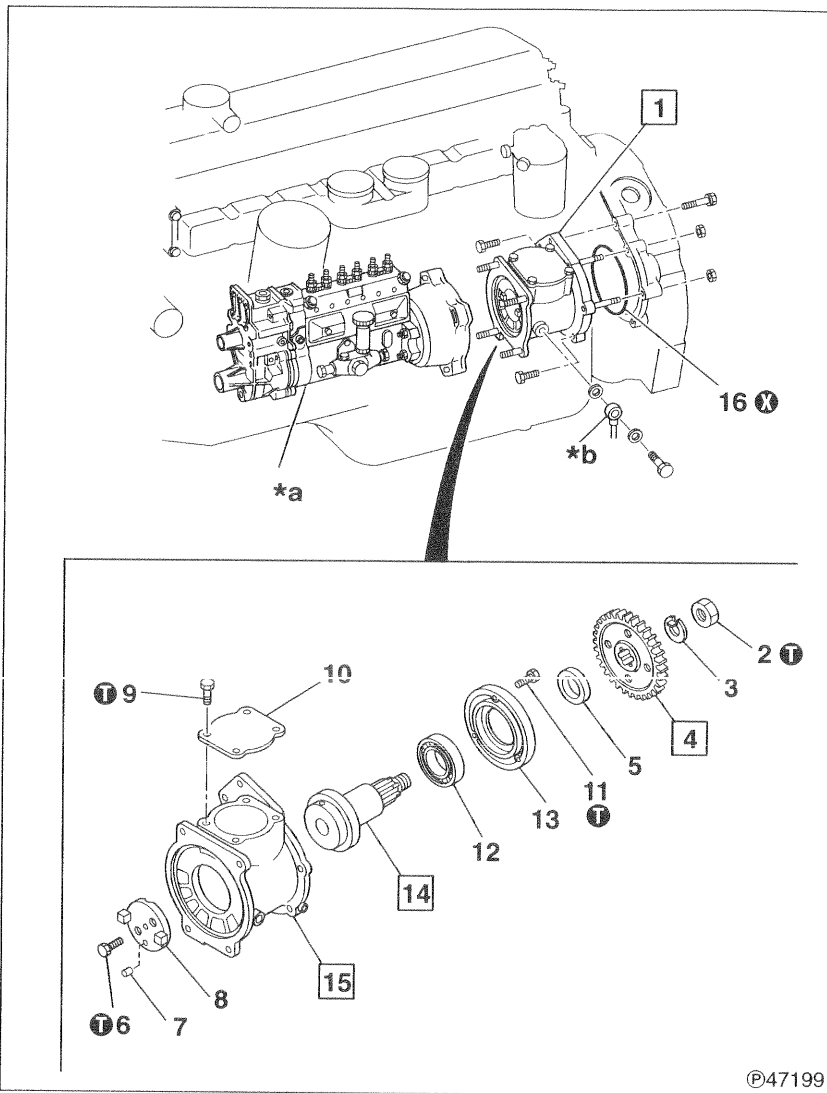

## ● Disassembly sequence

- 1 Injection pump drive assembly
- 2 Nut
- 3 Lock washer
- 4 Drive gear
- 5 Collar
- 6 Bolt
- 7 Pin
- 8 Coupling
- 9 Bolt
- 10 Cover
- 11 Bolt
- 12 Bearing
- 13 Bearing holder
- 14 Shaft
- 15 Pump drive case
- 16 O-ring

\*a: Injection pump assembly P.13A-32

\*b: Oil pipe P.13A-32

## ● Assembly sequence

Reverse the order of disassembly.

## Service standards

Unit: mm

Location	Maintenance item	Standard value	Limit	Remedy
14	Shaft end play	—	0.59	Replace
14, 15	Shaft-to-pump drive case clearance	—	0.12	Replace pump drive case

## ⓘ Tightening torques

Unit: N·m {kgf·m}

Location	Parts to be tightened	Tightening torque	Remarks
1	Eyebolt	21 {2.1}	—
2	Nut (drive gear mounting)	167 to 211 {17 to 21.5}	—
6	Bolt (coupling mounting)	30 to 36 {3.1 to 3.7}	—
9	Bolt (cover mounting)	25 to 29 {2.5 to 3}	—
11	Bolt (bearing holder mounting)	5.9 to 6.9 {0.6 to 0.75}	—

 Lubricant

Location	Points of application	Specified lubricant	Quantity
16	O-ring	Engine oil	As required

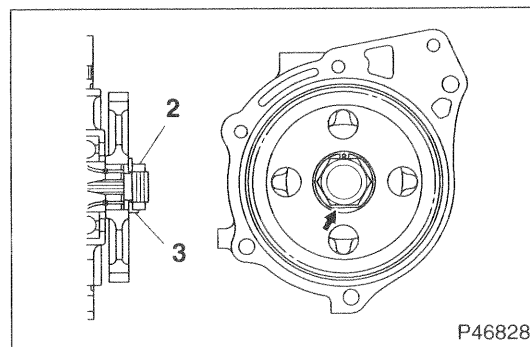
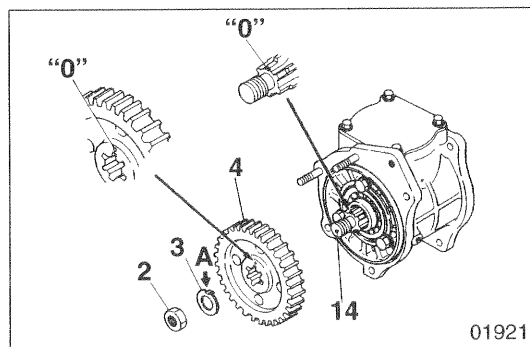
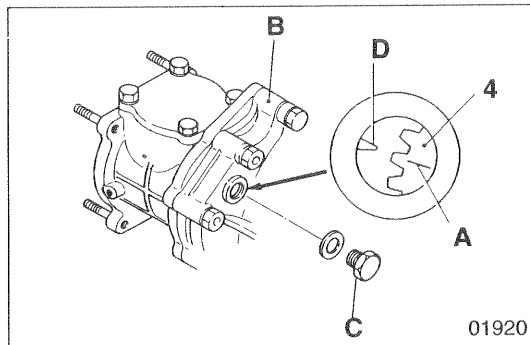
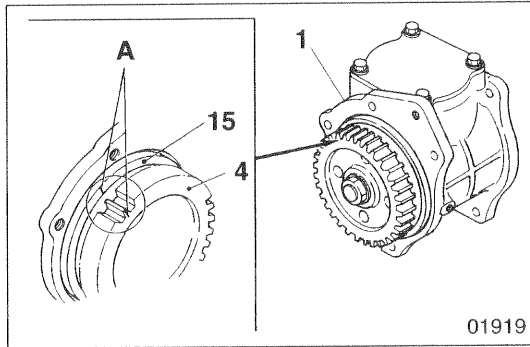

### ◆ Service procedure

#### 1 Installing injection pump drive assembly

- Bring cylinder No. 1 of the engine to the TDC position of its compression stroke.  Gr. 11
- Align the inscribed line **A** on the drive gear **4** of the injection pump drive assembly **1** with the inscribed line **A** on the pump drive case **15**.

- Remove the plug **C** from the flywheel housing **B**, then check that the inscribed line **A** on the drive gear **4** is aligned with the pointer **D**. If the line and pointer are not aligned, remove and refit the injection pump drive assembly.

#### 4 Installing drive gear

- Fit the drive gear **4** such that its "0" alignment mark is aligned with the "0" alignment mark on the shaft **14**. Then, fit the lock washer **3** such that its notch **A** is aligned with the drive gear alignment mark, and tighten the nut **2** to the specified torque.

- When the assembly is complete, bend the lock washer **3** down onto the nut **2**.

# INJECTION PUMP DRIVE <Oldham's Coupling Type>

## 14 15 Shaft-to-pump drive case clearance

If the clearance exceeds the specified limit, replace the pump drive case 15.

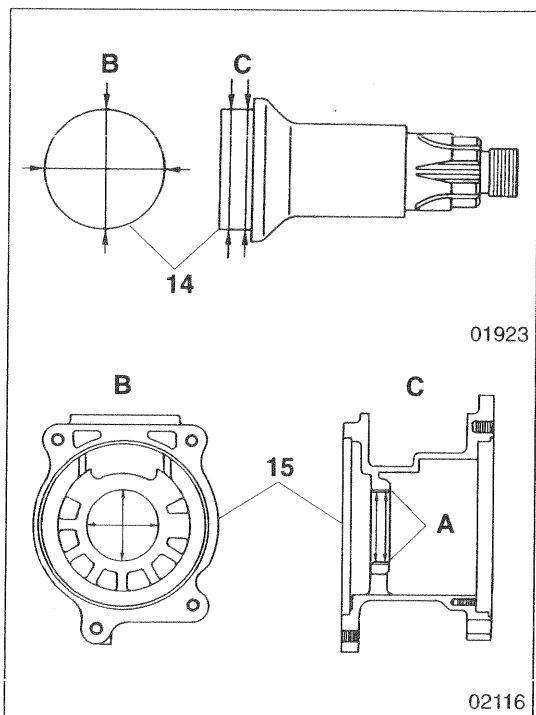

---

**MEMO**

---

# INJECTION PUMP DRIVE <Laminated Coupling Type>

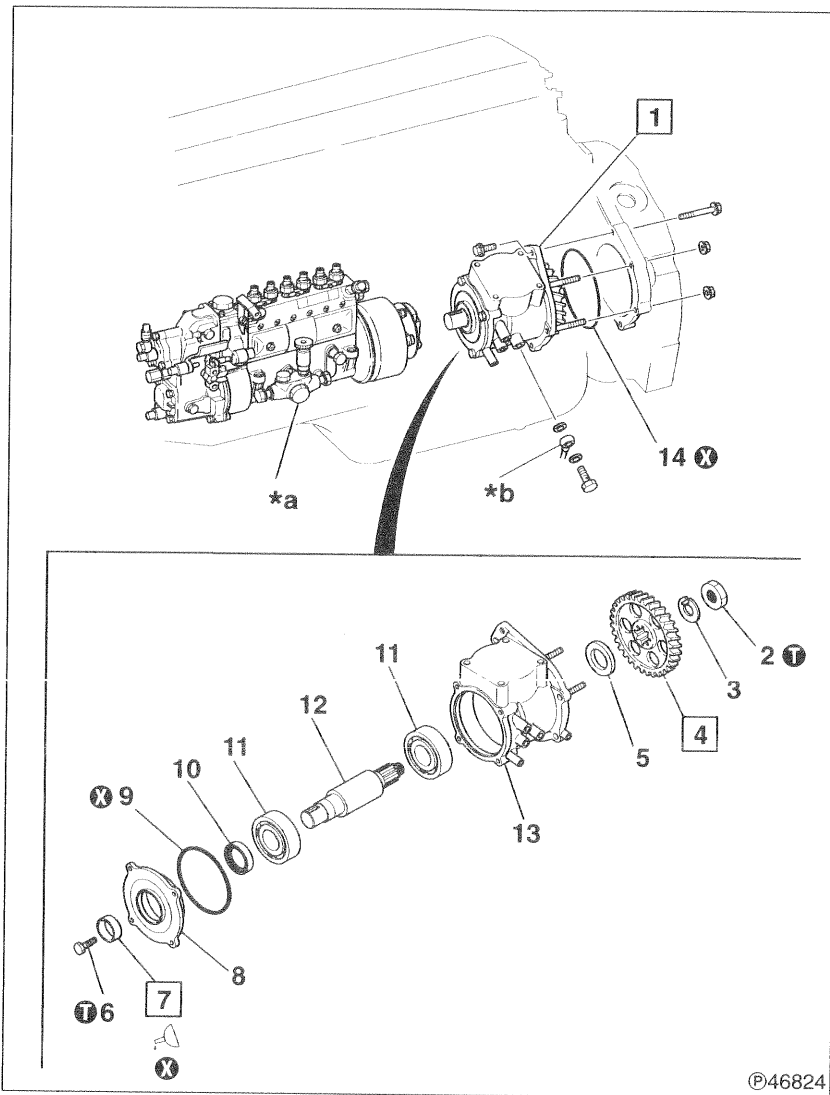

## ● Disassembly sequence

- 1 Injection pump drive assembly
- 2 Nut
- 3 Lock washer
- 4 Drive gear
- 5 Collar
- 6 Bolt
- 7 Oil seal
- 8 Bearing holder
- 9 O-ring
- 10 Sleeve
- 11 Bearing
- 12 Shaft
- 13 Pump drive case
- 14 O-ring

\*a: Injection pump assembly P.13A-34

\*b: Oil pipe P.13A-34

## ● Assembly sequence

Reverse the order of disassembly.

## Service standards

Unit: mm

Location	Maintenance item	Standard value	Limit	Remedy
12	Shaft end play	—	0.59	Replace

## ① Tightening torques

Unit: N·m {kgf·m}

Location	Parts to be tightened	Tightening torque	Remarks
2	Nut (drive gear mounting)	167 to 211 {17 to 21.5}	—
6	Bolt (bearing holder mounting)	13.7 to 17.7 {1.4 to 1.8}	—

## Lubricant

Location	Points of application	Specified lubricant	Quantity
14	O-ring	Engine oil	As required

## ◆ Service procedure

### 1 Installing injection pump drive assembly

- Set cylinder No. 1 of the engine at TDC on the compression stroke.  
 Gr. 11
- Align line **A** inscribed on drive gear **4** of injection pump drive assembly **1** with line **A** inscribed on pump drive case **13**.

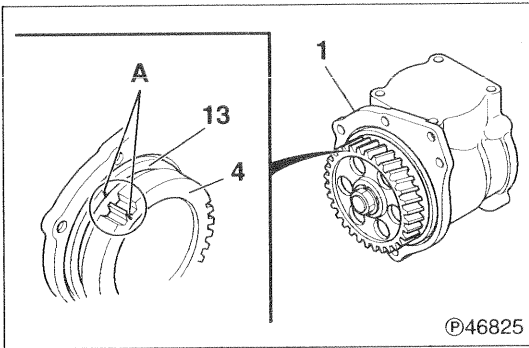

- Remove plug **C** from flywheel housing **B**. Check if line **A** inscribed on drive gear **4** is aligned with pointer **D**. If not, remove and refit injection pump drive assembly **1** to obtain the alignment.

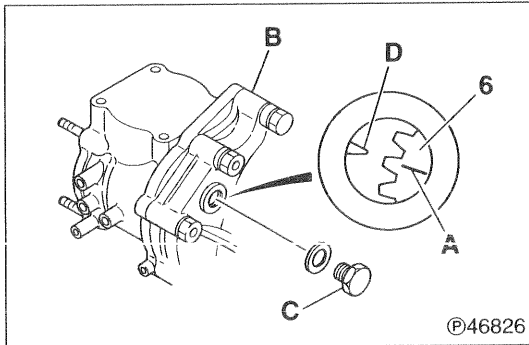

### 4 Installing drive gear

- Install drive gear **4** such that its "0" alignment mark is aligned with the "0" alignment mark on shaft **12**.
- Fit lock washer **3** such that its notch **A** is aligned with the "0" alignment mark on drive gear **4**. Tighten nut **2** to the specified torque.

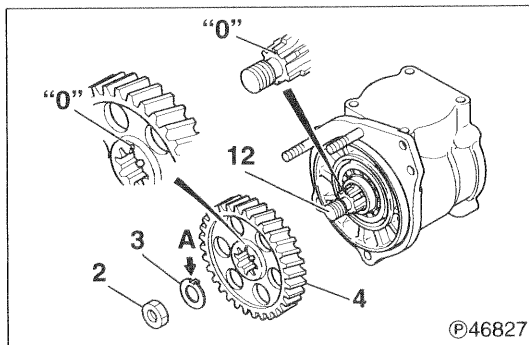

- After the drive gear is installed, bend lock washer **3** over nut **2**.

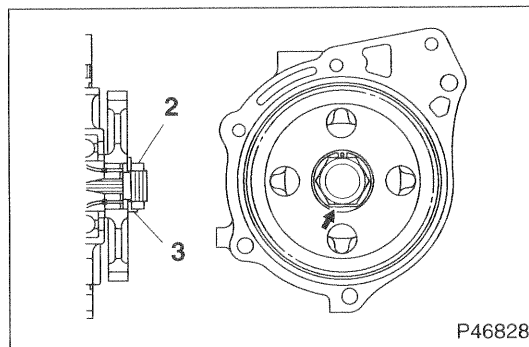

# INJECTION PUMP DRIVE <Laminated Coupling Type>

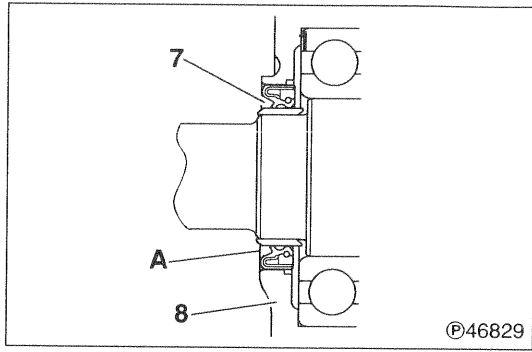

## 7 Installing oil seal

Face oil seal 7 as shown in the illustration. Then, fit it in bearing holder 8 by pressing evenly until it is flush with the end face A of the holder.

**M E M O**

---

# INJECTION NOZZLE <1-spring Type>

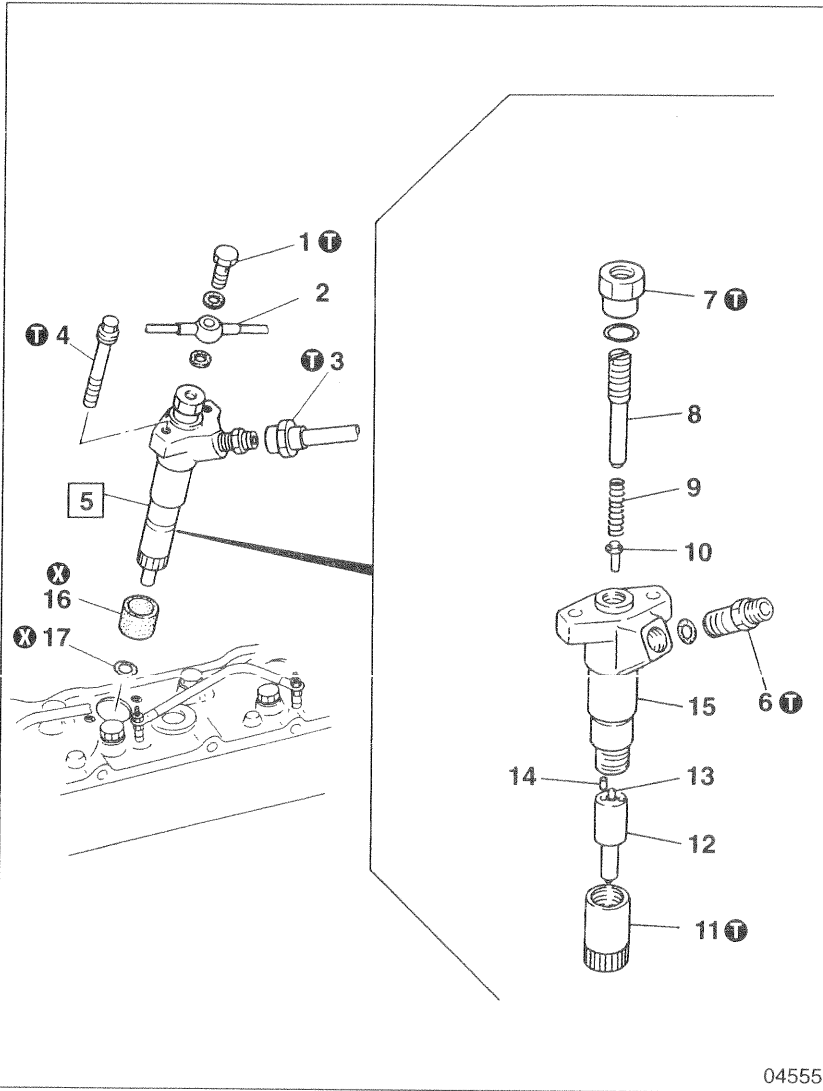

## ● Pre-disassembly Inspection

☞ P.13A-49

## ● Disassembly sequence

- 1 Eyebolt
- 2 Fuel leak-off pipe
- 3 Injection pipe
- 4 Bolt
- 5 Injection nozzle assembly
- 6 Connector
- 7 Cap nut
- 8 Adjusting screw
- 9 Spring
- 10 Push rod
- 11 Retaining nut
- 12 Nozzle
- 13 Needle valve
- 14 Pin
- 15 Nozzle holder
- 16 Dust seal
- 17 Gasket

⊗ : Non-reusable part

Repair kit : Nozzle Service Kit (for BOSCH  
AUTOMOTIVE SYSTEMS  
nozzles only)

## ● Assembly sequence

Reverse the order of disassembly.

## WARNING ⚠

To minimize the risk of fire, wipe up any spilled fuel.

## CAUTION ⚠

Under no circumstances change the needle valve 13 and nozzle 12 combination used in each injection nozzle assembly 5.

## NOTE

- Clean off any carbon deposits before disassembling, reassembling, or adjusting the injection nozzle assembly 5. Before disassembly, check the pressure and shape of the spray and inspect the assembly for fuel leaks. If no abnormality is apparent, do not commence disassembly.
- When fitting the injection nozzle assembly 5, tighten each of the two bolts 4 a little at a time.

## Service standards

Unit: mm

Location	Maintenance item	Standard value	Limit	Remedy
5	Injection pressure	17.7 $^{+0.49}_0$ MPa {180 $^{+5}_0$ kg/cm <sup>2</sup> }	—	Adjust

## ① Tightening torques

Unit: N·m {kgf·m}

Location	Parts to be tightened		Tightening torque	Remarks
1	Eyebolt (fuel leak-off pipe mounting)	BOSCH AUTOMOTIVE SYSTEMS	9.8 to 15 {1.0 to 1.5}	—
		DENSO	15 to 20 {1.5 to 2.0}	—
3	Injection pipe union nut		25 {2.5}	—
4	Bolt (injection nozzle mounting)	BOSCH AUTOMOTIVE SYSTEMS	15 {1.5}	—
		DENSO	12 to 14 {1.2 to 1.4}	—
6	Connector	BOSCH AUTOMOTIVE SYSTEMS	69 to 78 {7 to 8}	—
		DENSO	59 to 69 {6 to 7}	—
7	Cap nut		29 to 39 {3 to 4}	—
11	Retaining nut		59 to 78 {6 to 8}	—

## ⓐ Special tools

Unit: mm

Location	Tool name and shape	Part No.	Application
—	Nozzle Cleaning Tool	*105789-0010	Cleaning nozzles

\* BOSCH AUTOMOTIVE SYSTEMS part number

## ◆ Service procedure

## ● Pre-disassembly inspection

Fit the injection nozzle assembly 5 onto the nozzle tester A ready for inspection.

## NOTE

Before commencing inspection, operate the lever on the nozzle tester A two or three times to bleed all air out of the arrangement.

## (1) Checking valve opening pressure

- Push down the lever on the nozzle tester A at a rate of 1–2 seconds per stroke. The pressure gauge reading will gradually rise, then the needle will suddenly deflect. Note the pressure when the needle starts to deflect.
- If the measurement is out of specification, disassemble the nozzle, clean it, and make adjustments using the adjusting screw 8.
- If the measurement is still out of specification after adjustment, replace the injection nozzle assembly 5.

## WARNING ⚠

Do not touch the spray that comes out of the nozzle.

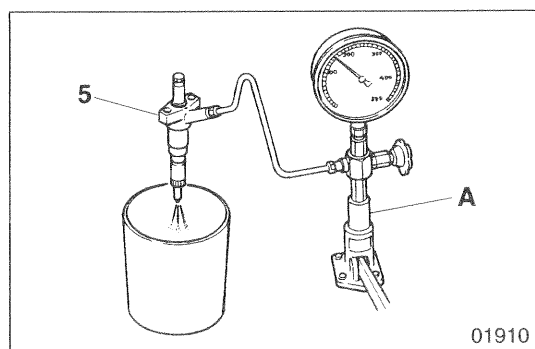

# INJECTION NOZZLE <1-spring Type>

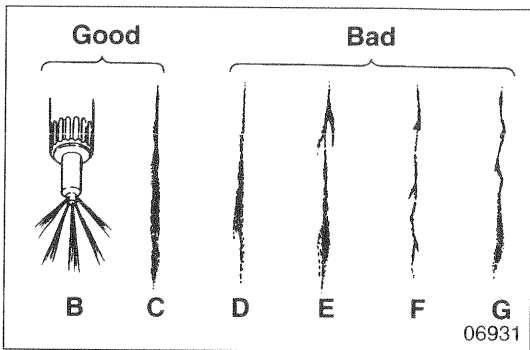

## (2) Inspecting spray condition

- Pump the lever on the nozzle tester **A** at a rate of about 1–2 seconds per stroke, and maintain a continuous spray.

**B**: Even spray from all five injection orifices (Good)

**C**: Even and symmetrical spray (Good)

**D**: Asymmetrical spray (Bad)

**E**: Branched spray (Bad)

**F**: Thin spray (Bad)

**G**: Irregular spray (Bad)

- If the spray is unsatisfactory, disassemble and clean the injection nozzle assembly **5**, then inspect the spray again. If the spray is still unsatisfactory, replace the injection nozzle assembly **5**.
- Check that no fuel drips from the nozzle after the spray is complete.

**WARNING** ⚠

Do not touch the spray that comes out of the nozzle.

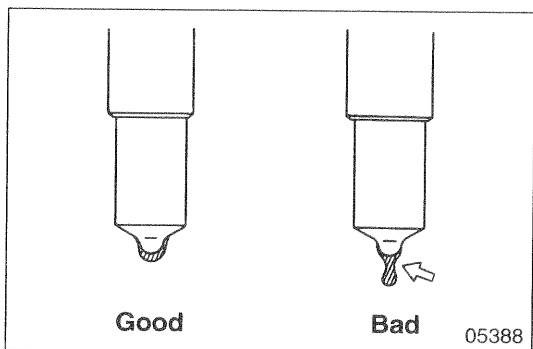

## (3) Inspecting for leaks

- Slowly increase the nozzle pressure to 1.96 MPa {20 kgf/cm<sup>2</sup>} below the specified valve opening pressure. Maintain this pressure for 10 seconds and check that no fuel drips from the end of the nozzle.
- If the injection nozzle assembly **5** appears defective, disassemble and clean it, then inspect it again. If the injection nozzle assembly **5** still appears defective, it must be replaced.

## 5 Injection nozzle assembly

[Disassembly]

**CAUTION** ⚠

- Do not touch the sliding parts **A** of the needle valve **7**.
- Do not change the needle valve **13** and nozzle **12** combination on each cylinder.

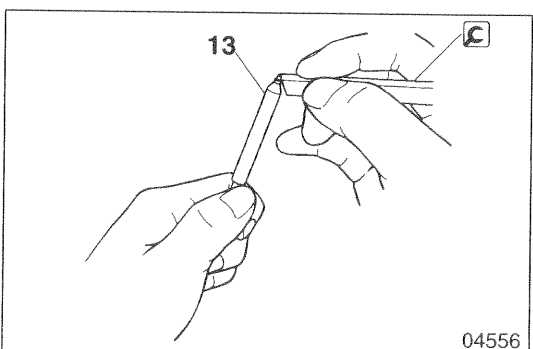
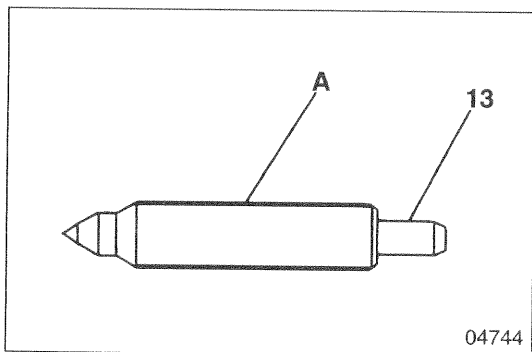

[Cleaning]

Wash the needle valve **13** and nozzle **12** in gas oil, then use the  Cleaning Tool Set to remove any carbon deposits in accordance with the following procedure.

- Remove carbon from the end of the needle valve **13** using the Cleaning Bar of the  Cleaning Tool Set.

**CAUTION** ⚠

Do not use a wire brush or any hard metallic object for cleaning.

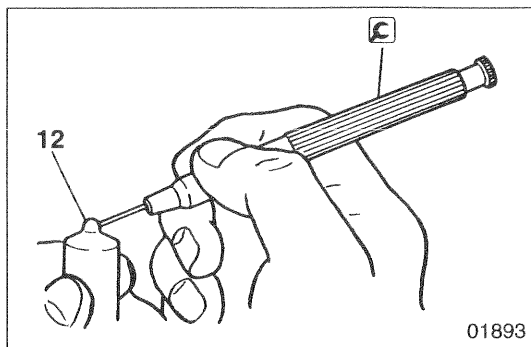

- Remove carbon from the injection orifice of the nozzle **12** using the Needle Cleaner of the  Cleaning Tool Set. Insert the Needle Cleaner and rotate it to dislodge the carbon.

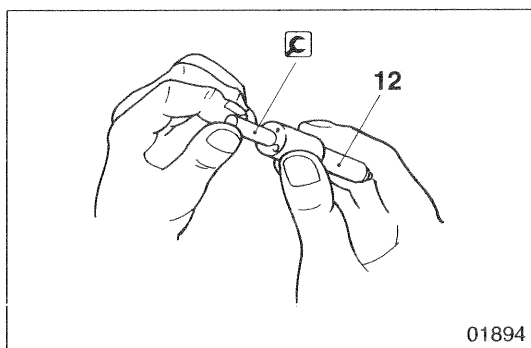

- Clean the seat of the nozzle **12** using the Cleaning Scraper of the  Cleaning Tool Set.
- To remove burned and hardened carbon, use FUSO Carbon Remover.

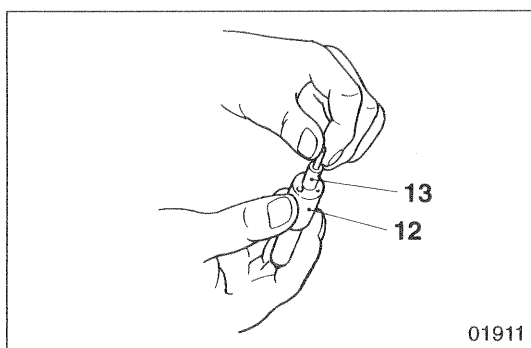

[Inspection]

- Wash the needle valve **13** and nozzle **12** in gas oil, then fit them together.
- Pull up the needle valve **13** by approximately 1/3 of its entire stroke, then check that it drops under its own weight. Repeat this test several times, turning the needle valve each time.
- If the needle valve **13** does not drop as required, wash it in gas oil and carry out this test again. If the needle valve is still defective, replace the needle valve and nozzle **12** as a set.

**NOTE**

Whenever a nozzle **12** is replaced, the nozzle and needle valve **13** must be replaced as a set using Nozzle Service Kit. (This applies to BOSCH AUTOMOTIVE SYSTEMS products only.)

# INJECTION NOZZLE <2-spring Type: BOSCH AUTOMOTIVE SYSTEMS>

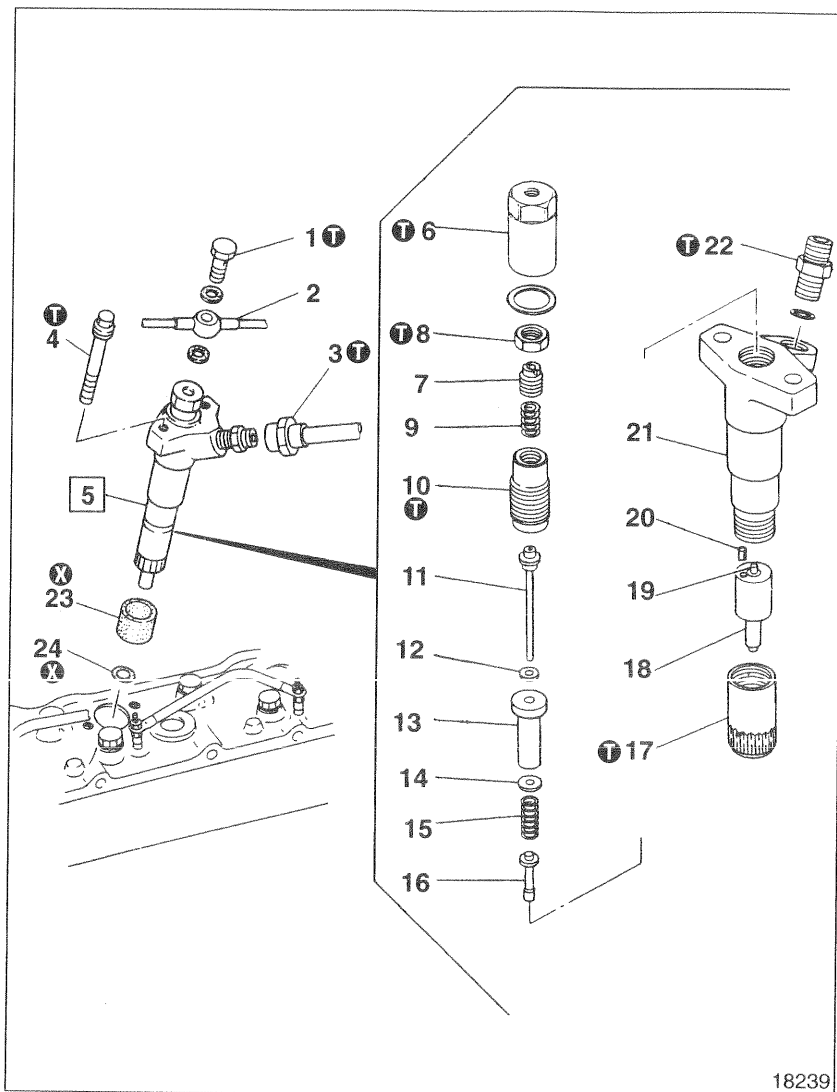

## ● Pre-disassembly inspection

📖 P.13A-54

## ● Disassembly sequence

- 1 Eyebolt
- 2 Fuel leak-off pipe
- 3 Injection pipe
- 4 Bolt
- 5 Injection nozzle assembly
- 6 Cap nut
- 7 Adjusting screw
- 8 Lock nut
- 9 2nd spring
- 10 Set screw
- 11 2nd push rod
- 12 Shim (for adjusting prelift)
- 13 Spacer
- 14 Shim (for adjusting valve opening pressure)
- 15 1st spring
- 16 1st push rod
- 17 Retaining nut
- 18 Nozzle
- 19 Needle valve
- 20 Pin
- 21 Nozzle holder
- 22 Nozzle holder joint
- 23 Dust seal
- 24 Gasket

⊗ : Non-reusable part

## ● Assembly sequence

Reverse the order of disassembly.

## WARNING ⚠

To minimize the risk of fire, wipe up any spilled fuel.

## CAUTION ⚠

Under no circumstances change the needle valve 19 and nozzle 18 combination used in each injection nozzle assembly 5.

## NOTE

- Clean off any carbon deposits before disassembling, reassembling, or adjusting the injection nozzle assembly 5. Before disassembly, check the pressure and shape of the spray and inspect the assembly for fuel leaks. If no abnormality is apparent, do not commence disassembly.
- When fitting the injection nozzle assembly 5, tighten each of the two bolts 4 a little at a time.

## Service standards

Unit: mm

Location	Maintenance item		Standard value	Limit	Remedy
5	Injection pressure	1st valve opening pressure	16.7 $^{+0.49}_0$ MPa {170 $^{+5}_0$ kgf/cm <sup>2</sup> }	—	Adjust
		2nd valve opening pressure (cover pressure)	21.6 $^{+0.49}_0$ MPa {220 $^{+5}_0$ kgf/cm <sup>2</sup> }	—	
	Prelift		0.08	—	Adjust

## ① Tightening torques

Unit: N·m {kgf·m}

Location	Parts to be tightened	Tightening torque	Remarks
1	Eyebolt (fuel leak-off pipe mounting)	9.8 to 15 {1.0 to 1.5}	—
3	Injection pipe union nut	25 {2.5}	—
4	Bolt (injection nozzle mounting)	15 {1.5}	—
6	Cap nut	39 to 49 {4 to 5}	—
8	Lock nut	20 to 25 {2 to 2.5}	—
10	Set screw	49 to 59 {5 to 6}	—
17	Retaining nut	59 to 79 {6 to 8}	—
22	Nozzle holder joint	69 to 79 {7 to 8}	—

## ☐ Special tools

Unit: mm

Location	Tool name and shape	Part No.	Application
5	Nozzle Cleaning Tool	☐a ☆105785-1010	Cleaning injection nozzle assemblies
	Adjusting Device	☆105789-0500	
	*Retaining Nut (for adjustment)	☐b ☆157892-1420	
	*Gasket	☐c ☆157892-1500	
	*Adjusting Device	☐d ☆157892-0220	
	*Dial Gauge	☐e ☆157954-3800	
	*Base	☐f ☆157892-1800	
	*Pin (ℓ = 60.5 mm)	☐g ☆157892-1100	
	*Connector	☐h ☆157892-1320	
	*Pin (ℓ = 50 mm)	☐j ☆157892-1200	
	*Gasket	☐k ☆026508-1140	

☆ BOSCH AUTOMOTIVE SYSTEMS product number

\* Component of Adjusting Device (105789-0500)

## ◆ Service procedure

### ● Pre-disassembly inspection

Fit the injection nozzle assembly 5 onto the nozzle tester A ready for inspection.

### NOTE

Before commencing inspection, operate the lever on the nozzle tester A two or three times to bleed all air out of the arrangement.

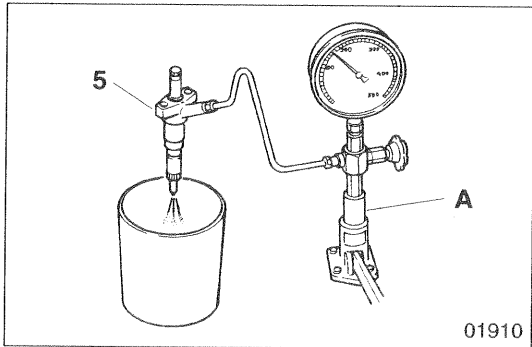

### (1) Checking valve opening pressure

- Push down the lever on the nozzle tester A at a rate of 1–2 seconds per stroke. The pressure gauge reading will gradually rise, then the needle will suddenly deflect. Note the pressure when the needle starts to deflect.
- If the measurement is out of specification, disassemble the nozzle, clean it, and make adjustments using the shims 12, 14.
- If the measurement is still out of specification after adjustment, replace the injection nozzle assembly 5.

### WARNING ⚠

Do not touch the spray that comes out of the nozzle.

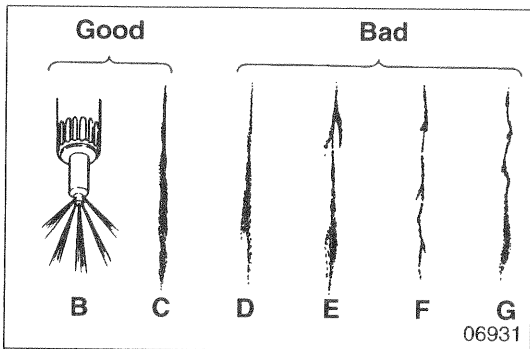

### (2) Inspecting spray condition

- Pump the lever on the nozzle tester A at a rate of about 1–2 seconds per stroke, and maintain a continuous spray.

B: Even spray from all five injection orifices (Good)

C: Even and symmetrical spray (Good)

D: Asymmetrical spray (Bad)

E: Branched spray (Bad)

F: Thin spray (Bad)

G: Irregular spray (Bad)

- If the spray is unsatisfactory, disassemble and clean the injection nozzle assembly 5, then inspect the spray again. If the spray is still unsatisfactory, replace the injection nozzle assembly 5.

- Check that no fuel drips from the nozzle after the spray is complete.

### WARNING ⚠

Do not touch the spray that comes out of the nozzle.

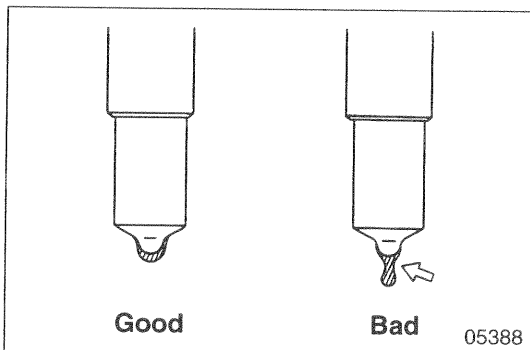

### (3) Inspecting for leaks

- Slowly increase the nozzle pressure to 1.96 MPa {20 kgf/cm<sup>2</sup>} below the specified 1st valve opening pressure. Maintain this pressure for 10 seconds and check that no fuel drips from the end of the nozzle.
- If the injection nozzle assembly 5 appears defective, disassemble and clean it, then inspect it again. If the injection nozzle assembly 5 still appears defective, it must be replaced.

## 5 Injection nozzle assembly

[Disassembly]

### CAUTION

- Do not touch the sliding parts A of the needle valve 19.
- Do not change the needle valve 19 and nozzle 18 combination on each cylinder.

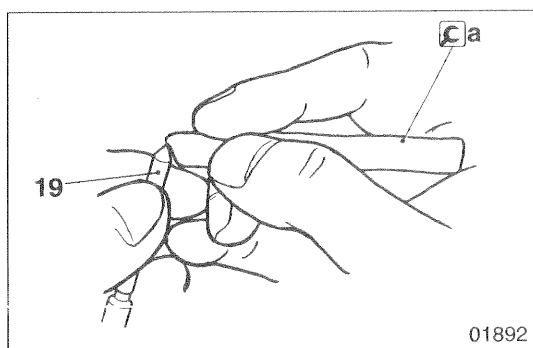
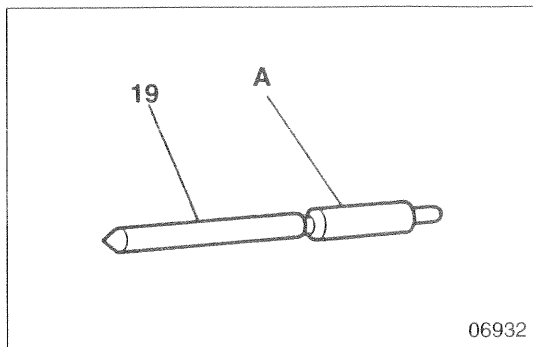

[Cleaning]

Wash the needle valve 19 and nozzle 18 in gas oil, then use the a Cleaning Tool Set to remove any carbon deposits in accordance with the following procedure.

- Remove carbon from the end of the needle valve 19 using the Cleaning Bar of the a Cleaning Tool Set.

### CAUTION

Do not use a wire brush or any hard metallic object for cleaning.

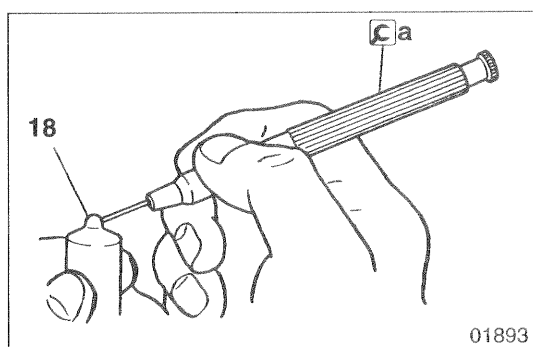

- Remove carbon from the injection orifice of the nozzle 18 using the Needle Cleaner of the a Cleaning Tool Set. Insert the needle cleaner and rotate it to dislodge the carbon.

Cleaning needle diameter: 0.31 mm or smaller.

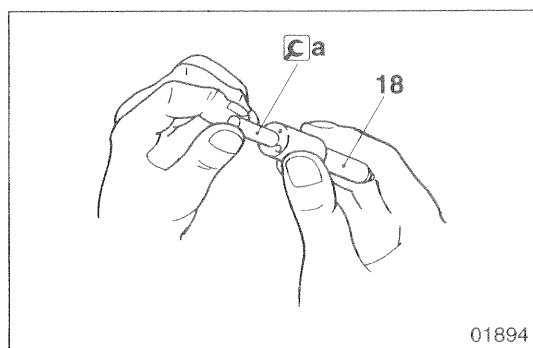

- Clean the seat of the nozzle 18 using the Cleaning Scraper of the a Cleaning Tool Set.
- To remove burned and hardened carbon, use FUSO Carbon Remover.

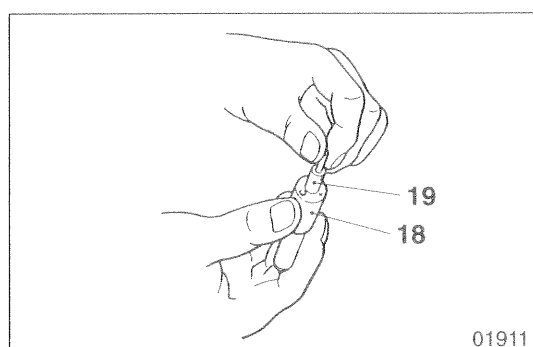

[Inspection]

- Wash the needle valve 19 and nozzle 18 in gas oil, then fit them together.
- Pull up the needle valve 19 by approximately 1/3 of its entire stroke, then check that it drops under its own weight. Repeat this test several times, turning the needle valve each time.
- If the needle valve 19 does not drop as required, wash it in gas oil and carry out this test again. If the needle valve is still defective, replace the needle valve and nozzle 18 as a set.

# INJECTION NOZZLE <2-spring Type: BOSCH AUTOMOTIVE SYSTEMS>

---

## NOTE

After replacing any nozzle 18, be sure to readjust the prelift and ensure that the valve opening pressure is up to specification.

[Adjustment]

During reassembly, make adjustments in the sequence shown below.

## CAUTION

- Before making adjustments, wash all parts in gas oil and ensure that they are free of dirt and other foreign material.
  - Do not touch the sliding surfaces of the needle valve 19.
- 

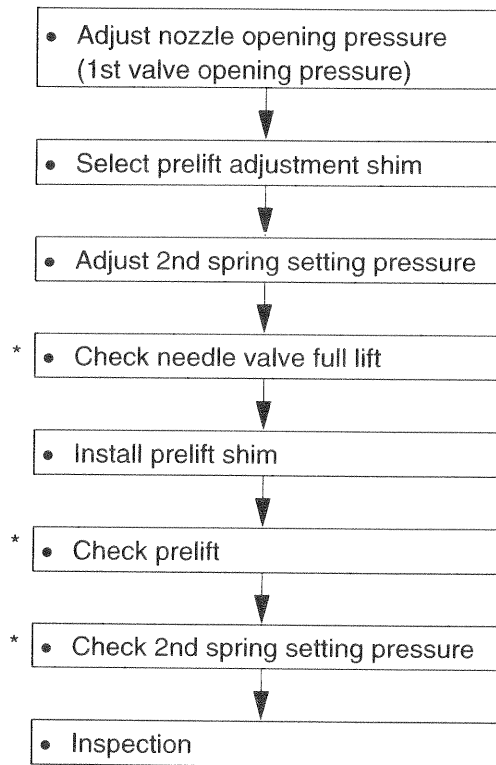

\* Carry out if necessary.

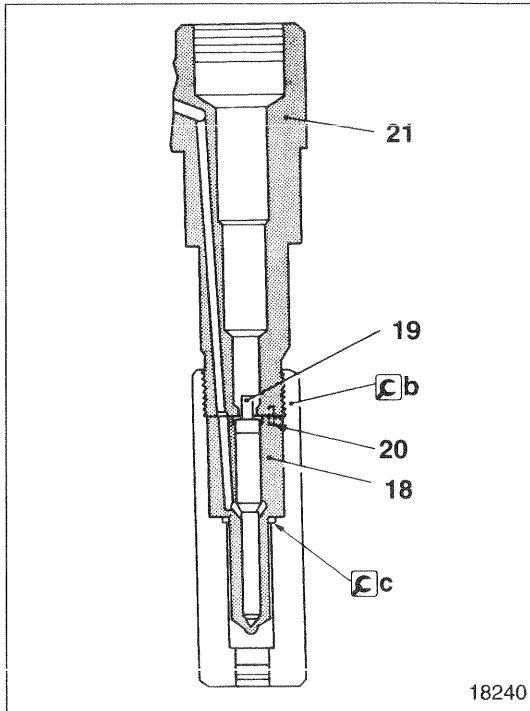

- Adjusting nozzle opening pressure (1st valve opening pressure)
- Fit the nozzle 18 and needle valve 19 into the nozzle holder using the **b** Retaining Nut for Adjustment and **c** Gasket.

#### NOTE

- Before tightening the **b** Retaining Nut for Adjustment, check that the pin 20 is fully seated in the nozzle 18. Tighten the retaining nut to finger tightness, then tighten it to the specified torque using a torque wrench.

Specified torque: 59 to 79 N·m {6 to 8 kgf·m}

- Remove the bolt from the end of the **b** retaining nut.

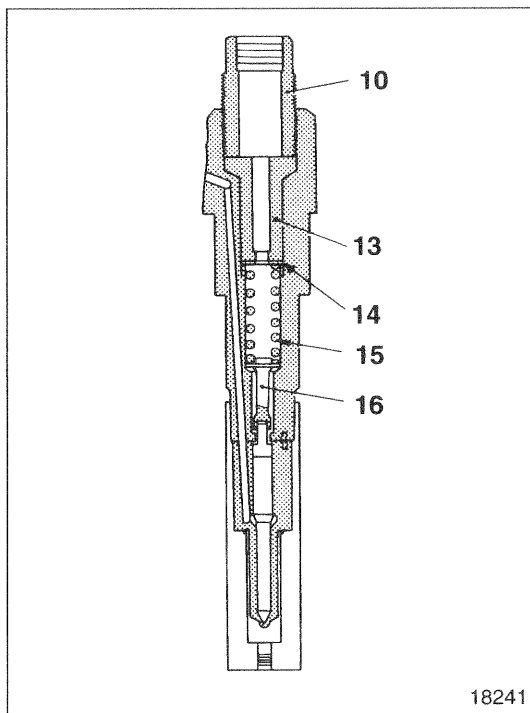

- Insert the 1st push rod 16, 1st spring 15, valve opening pressure adjustment shim 4, and spacer 13 into the nozzle holder. (For the time being, use a shim of approximately 1 mm in thickness.) Then, tighten the set screw 10 to the specified torque.

# INJECTION NOZZLE <2-spring Type: BOSCH AUTOMOTIVE SYSTEMS>

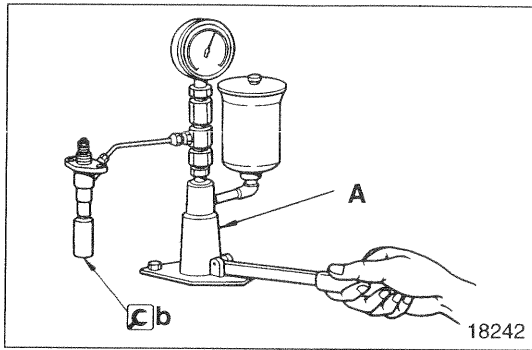

- Fit the nozzle holder 21 onto the nozzle tester A and measure the 1st valve opening pressure.
- If the measurement is out of the specification, adjust by shim 14. Shims are available in the following thicknesses: 0.50, 0.52, 0.54, 0.56, 0.58, 0.60, 0.70, 0.80, 0.90, 1.00, 0.10, 0.20, 0.30, and 0.40 mm.

## NOTE

- Before using any shim, check its thickness using a micrometer.
- These shims are also used for prelift adjustment.
- A 0.02 mm change in shim thickness corresponds to a 24 kPa {2.4 kgf/cm<sup>2</sup>} change in valve opening pressure.
- Leave the bolt off the end of the Retaining Cb Nut.

## ● Selecting prelift adjustment shim

- Fit the Ce Dial Gauge onto the Cd Adjusting Device. Then, fit the 2nd push rod 11 into the Cf Base and mount the assembly in a vise. Next, set the Cg Pin and Adjusting Device as shown in the illustration, and zero the Dial Gauge.
- Fit the 2nd push rod 11 into the nozzle holder.

## NOTE

Do not install the 2nd spring 11 and prelift adjustment shim 12.

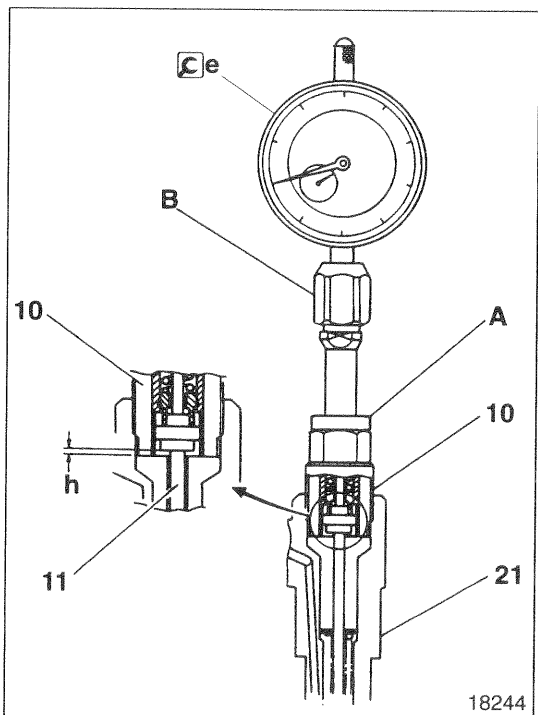
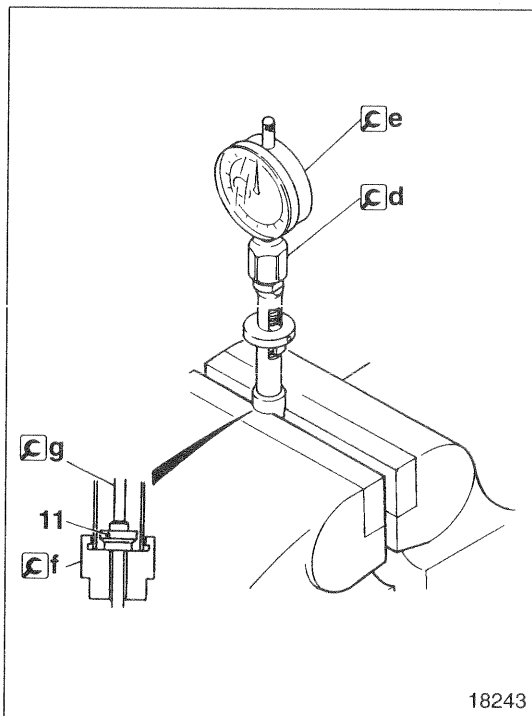

- Using the intermediate screw A of the Cd Adjusting Device, mount the Adjusting Device on the set screw 10. Then, hold the holder B of the Ce Dial Gauge and move it up and down to check that the gauge operates smoothly.
- Still holding the holder of the dial gauge, push down the gauge and read its lift measurement h.

## NOTE

Read to a precision of 1/100 mm.

- Select the prelift adjustment shim 12 as follows:

$$t = \ell + h$$

where

t: Shim thickness (as measured)

ℓ: Prelift (nominal value)

h: Dimension measured in previous step of procedure

$$T = t \pm 0.015 \text{ mm}$$

T = t ± 0.015 mm

where T: Thickness of shim to be used

- Remove the Cd Adjusting Device from the nozzle holder 21.

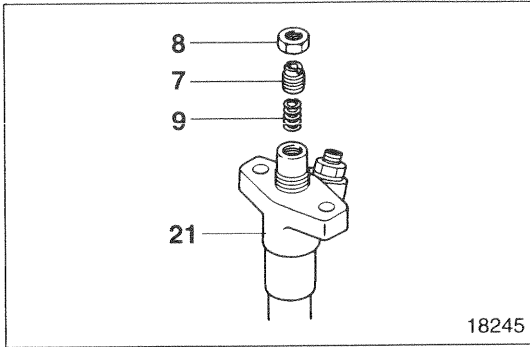

### ● Adjusting 2nd spring setting pressure (open pressure)

- Fit the 2nd spring 9 and adjusting screw 7 into the nozzle holder 21.
- Tighten the lock nut 8 to the specified torque.

#### NOTE

Do not install the prelift adjustment shim.

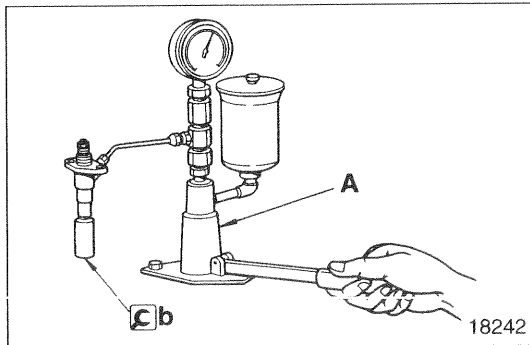

- Measure the 2nd spring setting pressure (open pressure) using the nozzle tester A.

#### NOTE

Leave the bolt off the end of the **b** Retaining Nut.

- If the measurement is out of the specification, adjust by the adjusting screw 7.

Nominal value: 24.7 to 25.3 MPa {252 to 258 kgf/cm<sup>2</sup>}

- After adjustment, tighten the lock nut 8 to the specified torque.

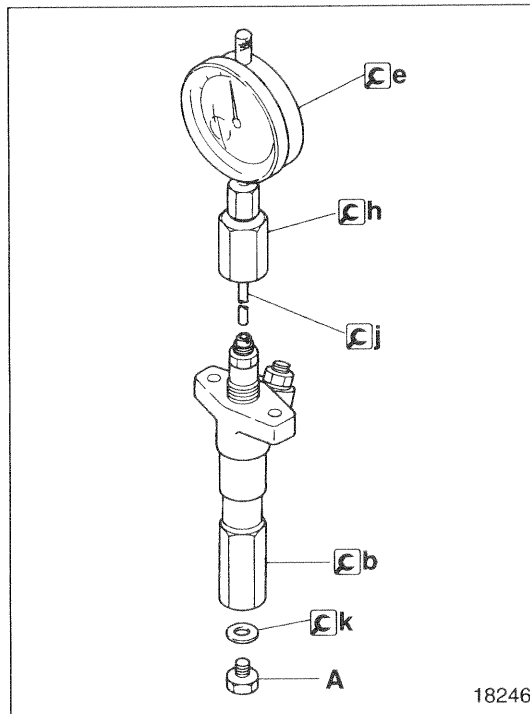

### ● Adjusting needle valve full lift

- Fit the special tools shown in the illustration, then zero the **e** Dial Gauge.
- **h** Connector tightening torque: 39 to 49 N·m {4 to 5 kgf·m}

A: Bolt

- Fit the nozzle 5 onto the nozzle tester, then operate the nozzle tester lever to bleed all air out of the **b** Retaining Nut (for adjustment). Also, check for fuel leaks.
- Using the nozzle tester lever, increase the pressure to 34.3 to 44.1 MPa {350 to 450 kgf/cm<sup>2</sup>} such that the nozzle's needle valve 19 lifts fully. Read the lift dimension shown by the Dial Gauge.
- Remove the **e** Dial Gauge, **h** Connector, and **j** Pin.

# INJECTION NOZZLE <2-spring Type: BOSCH AUTOMOTIVE SYSTEMS>

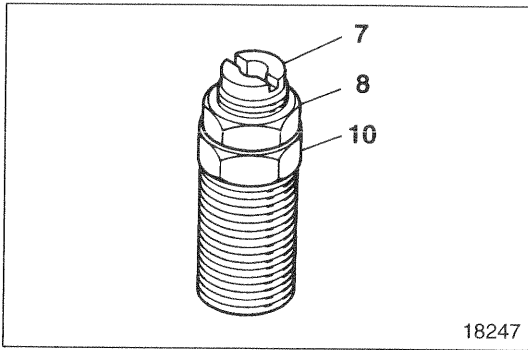

## ● Installing prelift adjustment shim

- Remove the set screw **10**, lock nut **8**, and adjusting screw **7** from the nozzle holder **21** as an assembly.

## CAUTION

Do not loosen the lock nut **8**. Loosening the lock nut would alter the 2nd spring setting pressure.

- Fit the prelift adjustment shim **12** between the spacer **13** and push rod **11**. Use the shim selected previously in accordance with the "Selecting Prelift Adjustment Shim" procedure.
- Install the 2nd push rod **11** and 2nd spring **9**.
- Fit the set screw **10**, lock nut **8**, and adjusting screw **7** as an assembly, and tighten the set screw to the specified torque.
- Measure the needle valve lift in accordance with the previously described procedure.  
The lift measured this time should be the value of "(full lift) – (prelift)".

## ● Checking prelift

- Check the prelift based on the previously measured "full lift" and "lift" dimensions.

$$L - S = \Delta \ell$$

$$\text{where } \ell - 0.02 \leq \Delta \ell \leq \ell + 0.02$$

$\Delta \ell$ : Prelift (as measured)

$\ell$ : Prelift (nominal value)

L: Needle valve full lift dimension (as measured)

S: Needle valve lift dimension (as measured) with prelift subtracted

If  $\Delta \ell$  is out of the specified range ( $\ell \pm 0.02$  mm), replace the prelift adjustment shim **12** in accordance with the previously described procedure, then repeat the last two procedures such that the  $\Delta \ell$  dimension falls within  $\ell \pm 0.02$  mm.

Select the thickness of the replacement shim ( $t'$ ) as follows:

$$t' = t + (\ell - \Delta \ell)$$

$$T = t' \pm 0.015 \text{ mm}$$

t: Thickness of shim installed

$t'$ : Shim thickness

T: Thickness of shim to be used

$\ell$ : Prelift (nominal value)

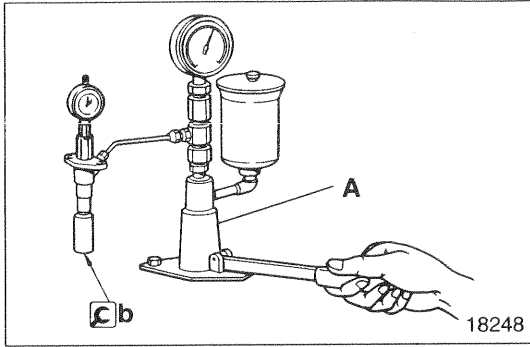

### ● Checking 2nd spring setting pressure (cover pressure)

- Check the prelift in accordance with the previously described procedure. Then, use the nozzle tester to increase the pressure again to 34.3 to 44.1 MPa {350 to 450 kgf/cm<sup>2</sup>} such that the needle valve 19 lifts fully.

#### NOTE

The **Cb** Retaining Nut (for adjustment) must have its end bolt fitted.

- With the needle valve 19 fully lifted, stop operating the lever of the nozzle tester **A**. The pressure will start to decrease, and the needle valve will drop.
- At the moment when the nozzle lift decreases to 0.05 mm, read the pressure gauge indication.  
Nominal value: 23.1 to 23.6 MPa {235 to 240 kgf/cm<sup>2</sup>}
- If the measured value is out of specification, adjust it. P.13A-59
- Remove the special tools.

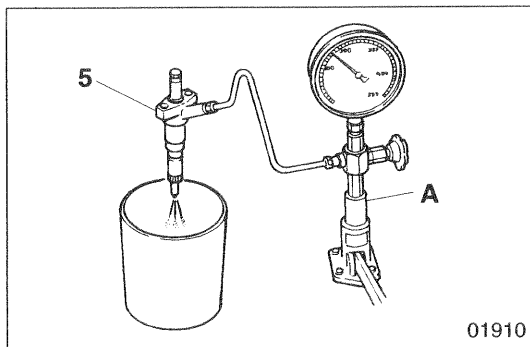

### ● Inspection

- Fit the injection nozzle assembly **5** onto the nozzle tester **A**, then check the 1st valve opening pressure, the spray condition, and the airtightness of the seat. Check also for fuel leaks.

#### NOTE

If the 1st valve opening pressure is out of specification, make adjustments again starting with the preliminary procedures.

# INJECTION NOZZLE <2-spring Type: DENSO>

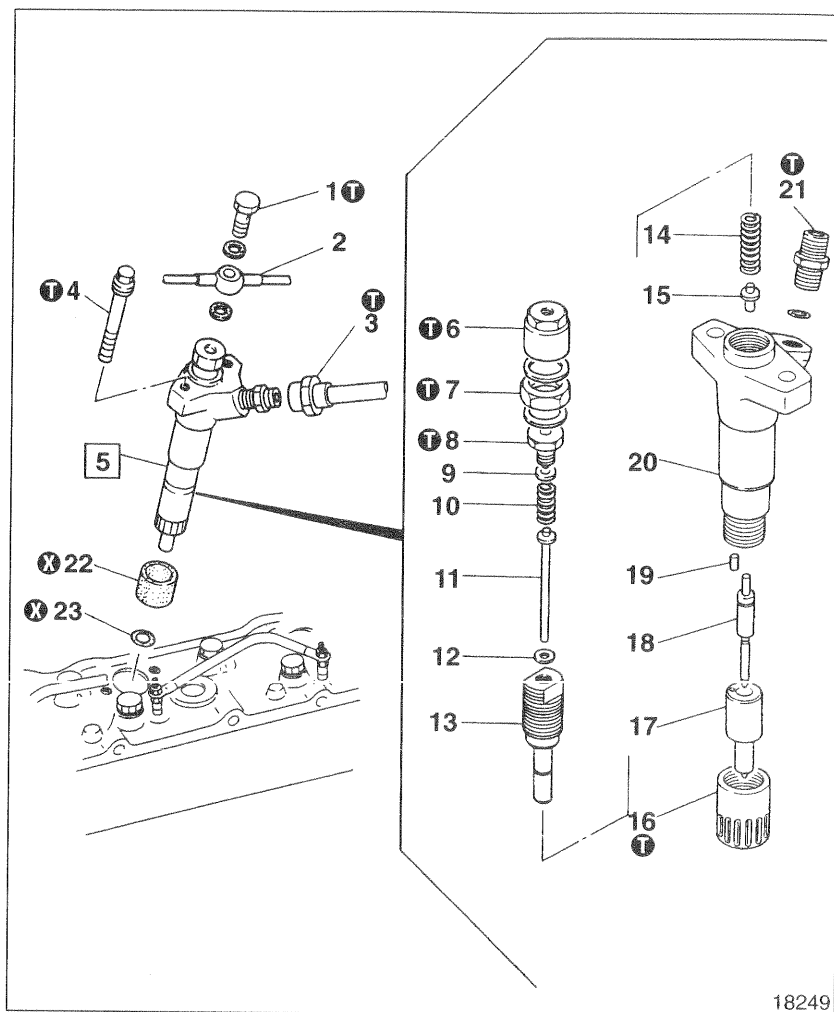

## ● Pre-disassembly inspection

☞ P.13A-63

## ● Disassembly sequence

- 1 Eyebolt
- 2 Fuel leak-off pipe
- 3 Injection pipe
- 4 Bolt
- 5 Injection nozzle assembly
- 6 Cap nut
- 7 Lock nut
- 8 Screw plug
- 9 Shim (for adjusting valve opening pressure)
- 10 2nd spring
- 11 2nd push rod
- 12 Shim (for adjusting prelift)
- 13 Capsule screw
- 14 1st spring
- 15 1st push rod
- 16 Retaining nut
- 17 Nozzle
- 18 Needle valve
- 19 Pin
- 20 Nozzle holder
- 21 Nozzle holder joint
- 22 Dust seal
- 23 Gasket

⊗ : Non-reusable part

## ● Assembly sequence

Reverse the order of removal.

## WARNING

To minimize the risk of fire, wipe up any spilled fuel.

## NOTE

Clean off any carbon deposits before disassembling, reassembling, or adjusting the injection nozzle assembly 5. Before disassembly, check the pressure and shape of the spray and inspect the assembly for fuel leaks. If no abnormality is apparent, do not commence disassembly.

## CAUTION

Under no circumstances change the needle valve 18 and nozzle 17 combination used in each injection nozzle assembly 5.

## NOTE

When fitting the injection nozzle assembly 5, tighten each of the two bolts 4 a little at a time.

## Service standards

Unit: mm



Location	Maintenance item		Standard value	Limit	Remedy
5	Injection pressure	1st valve opening pressure	16.67 $^{+0.98}_0$ MPa {170 $^{+10}_0$ kgf/cm <sup>2</sup> }	—	Adjust
		2nd valve opening pressure (cover pressure)	21.57 $^{+0.98}_0$ MPa {220 $^{+10}_0$ kgf/cm <sup>2</sup> }	—	
	Prelift		0.08 ± 0.02	—	Adjust

## ① Tightening torques

Unit: N·m {kgf·m}

Location	Parts to be tightened	Tightening torque	Remarks
1	Eyebolt (fuel leak-off pipe mounting)	15 to 20 {1.5 to 2.0}	—
3	Injection pipe union nut	25 {2.5}	—
4	Bolt (injection nozzle mounting)	12 to 14 {1.2 to 1.4}	—
6	Cap nut	39.2 to 49 {4 to 5}	—
7	Lock nut	58.8 to 68.6 {6 to 7}	—
8	Screw plug	29.4 to 39.2 {3 to 4}	—
16	Retaining nut	58.8 to 78.5 {6 to 8}	—
21	Nozzle holder joint	58.8 to 68.6 {6 to 7}	—

## ☒ Special tools

Location	Tool name and shape	Part No.	Application
—	Nozzle Cleaning Tool 	*105789-0010	Cleaning nozzles
—	2-Spring Nozzle Adjustment Tool	Holder 	*95091-10770
		Probe 	

\* DENSO product number

\* BOSCH AUTOMOTIVE SYSTEMS product number

## ◆ Service procedure

## ● Pre-disassembly inspection

Fit the injection nozzle assembly 5 onto the nozzle tester A ready for inspection.

## NOTE

Before commencing inspection, operate the lever on the nozzle tester A two or three times to bleed all air out of the arrangement.

## (1) Checking valve opening pressure

- Push down the lever on the nozzle tester A at a rate of 1–2 seconds per stroke. The pressure gauge reading will gradually rise, then the needle will suddenly deflect. Note the pressure when the needle starts to deflect.
- If the measurement is out of specification, disassemble the nozzle, clean it, and make adjustments using the shims 9, 12.
- If the measurement is still out of specification after adjustment, replace the injection nozzle assembly 5.

WARNING 

Do not touch the spray that comes out of the nozzle.

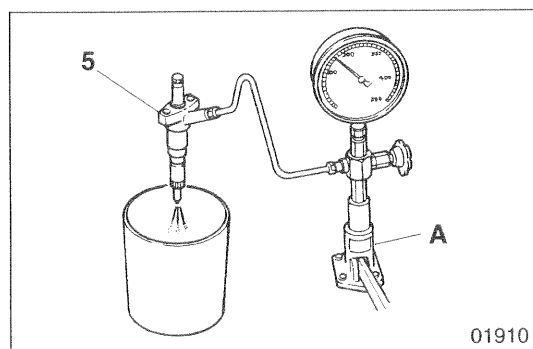

01910

# INJECTION NOZZLE <2-spring Type: DENSO>

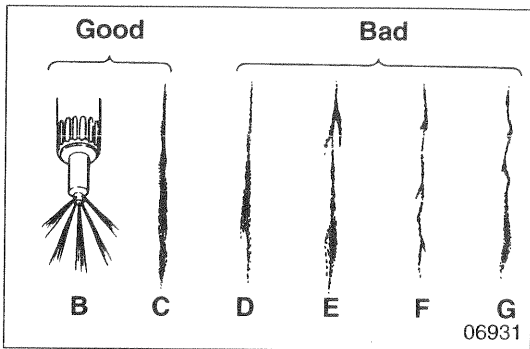

## (2) Inspecting spray condition

- Pump the lever on the nozzle tester **A** at a rate of about 1–2 seconds per stroke and maintain a continuous spray.

**B**: Even spray from all five injection orifices (Good)

**C**: Even and symmetrical spray (Good)

**D**: Asymmetrical spray (Bad)

**E**: Branched spray (Bad)

**F**: Thin spray (Bad)

**G**: Irregular spray (Bad)

- If the spray is unsatisfactory, disassemble and clean the injection nozzle assembly **5**, then inspect the spray again. If the spray is still unsatisfactory, replace the injection nozzle assembly **5**.
- Check that no fuel drips from the nozzle after the spray is complete.

### WARNING

Do not touch the spray that comes out of the nozzle.

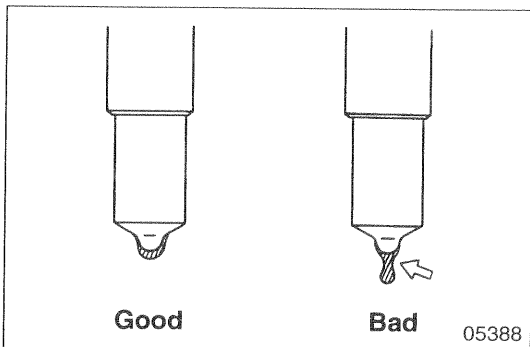

## (3) Inspecting for leaks

- Slowly increase the nozzle pressure to 1.96 MPa {20 kgf/cm<sup>2</sup>} below the specified 1st valve opening pressure. Maintain this pressure for 10 seconds and check that no fuel drips from the end of the nozzle.
- If the injection nozzle assembly **5** appears defective, disassemble and clean it, then inspect it again. If the injection nozzle assembly still appears defective, it must be replaced.

## 5 Injection nozzle assembly

[Disassembly]

### CAUTION

- Do not touch the sliding parts **A** of the needle valve **18**.
- Do not change the needle valve **18** and nozzle **17** combination on each cylinder.

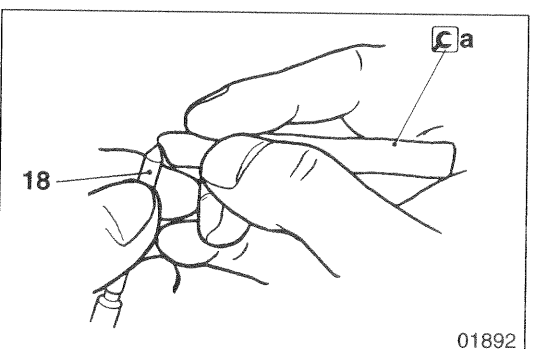
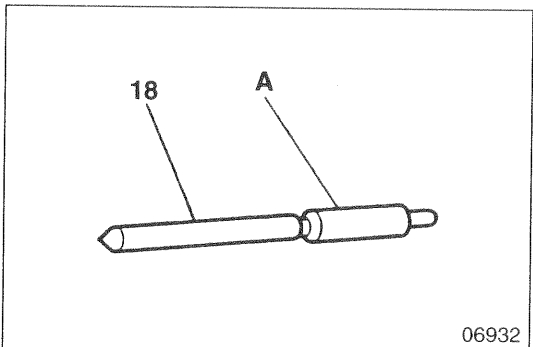

[Cleaning]

Wash the needle valve **18** and nozzle **17** in gas oil, then use the **Ca** Cleaning Tool Set to remove any carbon deposits in accordance with the following procedure.

- Remove carbon from the end of the needle valve **18** using the cleaning bar of the **Ca** Cleaning Tool Set.

### CAUTION

Do not use a wire brush or any hard metallic object for cleaning.

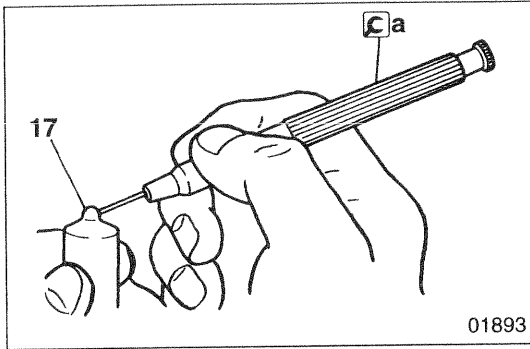

- Remove carbon from the injection orifice of the nozzle 17 using the needle cleaner of the **Ca** Cleaning Tool Set. Insert the needle cleaner and rotate it to dislodge the carbon.

Cleaning needle diameter: 0.315 mm or smaller.

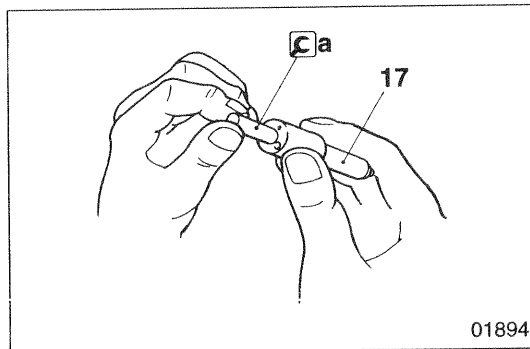

- Clean the seat of the nozzle 17 using the cleaning scraper of the **Ca** Cleaning Tool Set.
- To remove burned and hardened carbon, use FUSO Carbon Remover.

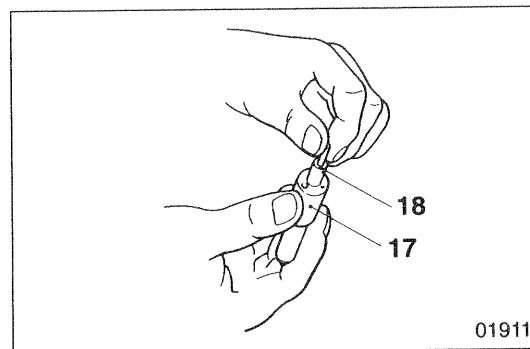

#### [Inspection]

- Wash the needle valve 18 and nozzle 17 in gas oil, then fit them together.
- Pull up the needle valve 18 by approximately 1/3 of its entire stroke, then check that it drops under its own weight. Repeat this test several times, turning the needle valve each time.
- If the needle valve 18 does not drop as required, wash it in gas oil and carry out this test again. If the needle valve is still defective, replace the needle valve and nozzle 17 as a set.

#### [Adjustment]

During reassembly, make adjustments in the sequence shown below.

#### **CAUTION** ⚠

- Before making adjustments, wash all parts in gas oil and ensure that they are free of dirt and other foreign material.
- Do not touch the sliding surfaces of the needle valve 18.

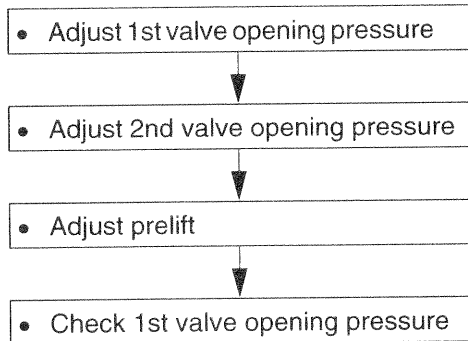

# INJECTION NOZZLE <2-spring Type: DENSO>

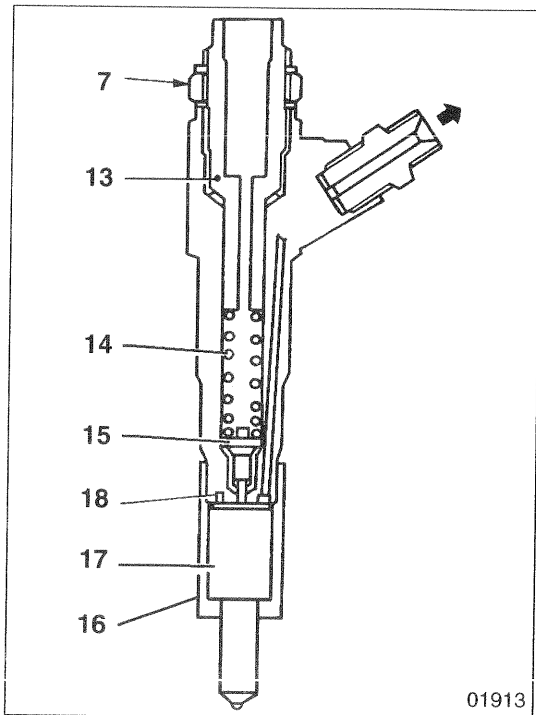

## ● Adjusting 1st valve opening pressure (injection pressure)

- Assemble the parts as shown in the illustration.

### NOTE

Check that the pin 19 is fully seated in the nozzle 17 before tightening the retaining nut 16 to the specified torque.

- Fit the injection nozzle assembly onto the nozzle tester, then adjust the valve opening pressure of the 1st spring by loosening the capsule screw 13.
- Lock the capsule screw 13 in position and tighten the lock nut 7 to the specified torque.

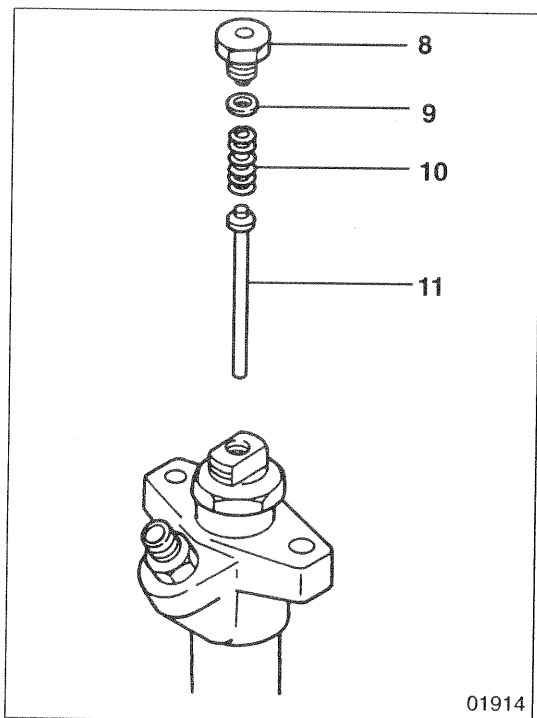

## ● Adjusting 2nd valve opening pressure

- Fit the 2nd push rod 11, 2nd spring 10, valve opening pressure adjustment shim 9, and screw plug 8. If the thickness of the valve opening pressure adjustment shim is not known, a 1.9 mm shim should be used as a guide.

### NOTE

Do not install the prelift adjustment shim 12.

- Fit the assembled arrangement onto the nozzle tester, then adjust the shim 9 thickness to achieve the specified nominal injection pressure. Shims are available in thicknesses from 0.50 to 2.50 mm.

### NOTE

- A 0.02 mm change in shim thickness corresponds to a 22 kPa {2.2 kgf/cm<sup>2</sup>} change in valve opening pressure.
- These shims 12 are also used for prelift adjustment.

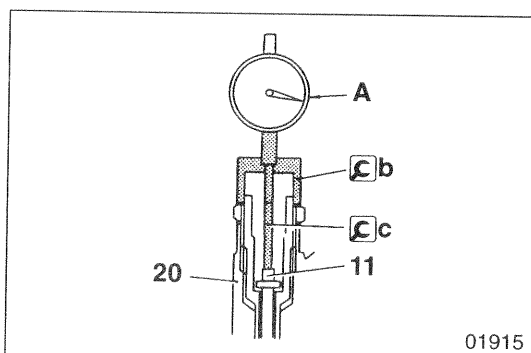

## ● Adjusting prelift

- Remove the screw plug 8, valve opening pressure adjustment shim 9, and 2nd spring 10. Then, assemble the dial gauge A, b Holder, and c Probe as shown in the illustration.
- Zero the dial gauge A.

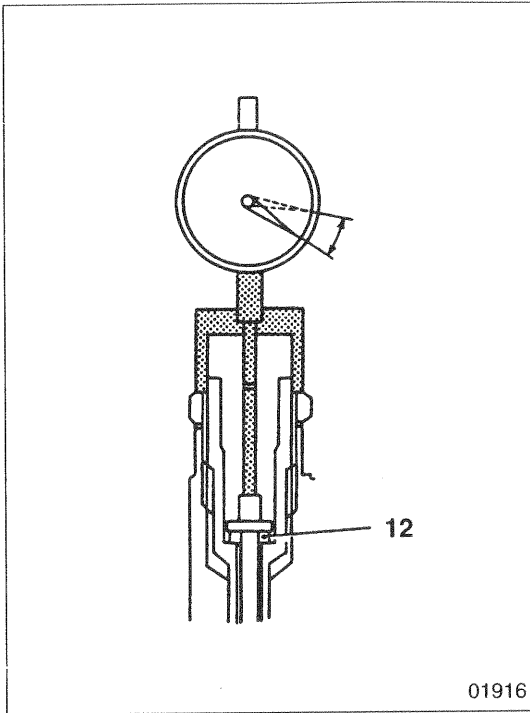

01916

- Remove the 2nd push rod **11** and fit the prelift adjustment shim **12**. Then, refit the dial gauge as described above and note the needle deflection. If the prelift measurement is out of specification, adjust it by changing the shim.

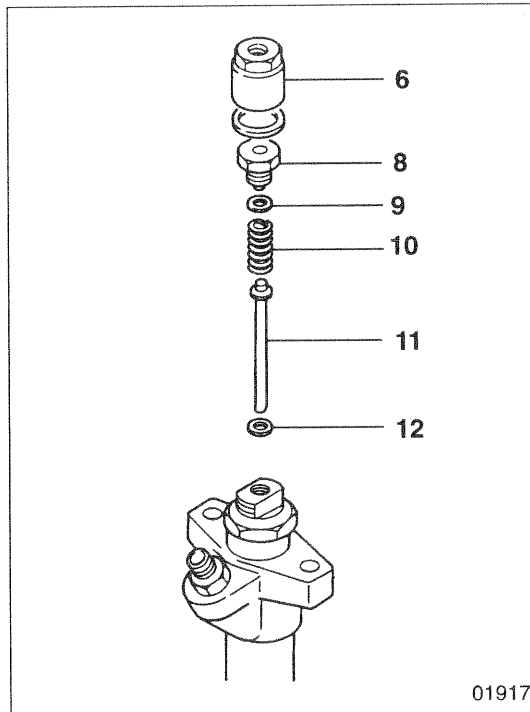

01917

#### ● Checking 1st valve opening pressure

- Assemble the parts shown in the illustration.

#### NOTE

Be sure to use the shims **12** selected in accordance with the procedures described earlier. Take care not to confuse the valve opening pressure shim **9** with the prelift shim **12**.

- Fit the injector nozzle assembly onto the nozzle tester and check the 1st valve opening pressure.

#### NOTE

If the 1st valve opening pressure is out of specification, carry out the entire adjustment procedure again.



# GROUP 14 COOLING

**SPECIFICATIONS ..... 14-2**

**STRUCTURE AND OPERATION**

- 1. Cooling System (Water Flow) ..... 14-2
- 2. Water Pump ..... 14-3
- 3. Thermostat ..... 14-3

**TROUBLESHOOTING ..... 14-4**

**ON-VEHICLE INSPECTION AND ADJUSTMENT**

- 1. Replacing Coolant and Cleaning Coolant System ..... 14-6
- 2. Air Bleeding of Cooling System ..... 14-8
- 3. Gas Leak Testing ..... 14-8

**RADIATOR ..... 14-9**

**COOLING FAN AND V-BELT ..... 14-10**

**WATER PUMP ..... 14-14**

**THERMOSTAT ..... 14-18**

# SPECIFICATIONS / STRUCTURE AND OPERATION

## SPECIFICATIONS

Item	Specifications
Cooling system	Forced water circulation type
Water pump type	Belt-driven involute type
Thermostat type	Wax pellet, bottom bypass type (with jiggle valve)
Automatic cooling fan coupling type	Constant control type
Radiator type	Tube and corrugated fin type
Coolant capacity $\text{dm}^3$ {L} (engine main body only)	13 {13}

## STRUCTURE AND OPERATION

### 1. Cooling System (Water Flow)

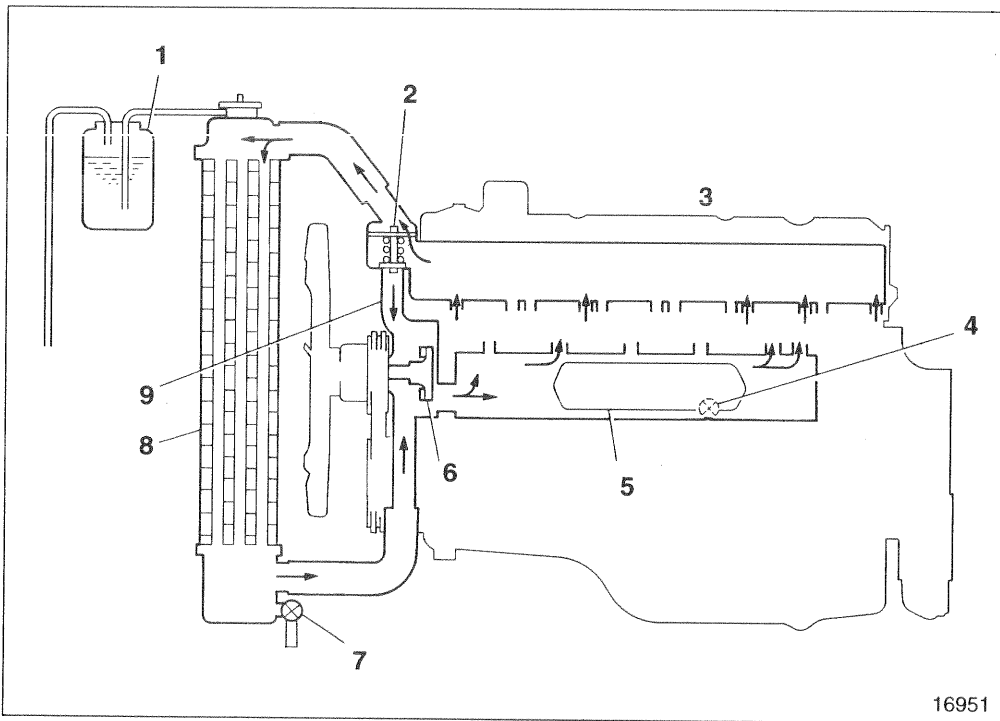

- 1 Reservoir tank
- 2 Thermostat
- 3 Cylinder head
- 4 Drain plug
- 5 Oil cooler
- 6 Water pump
- 7 Drain cock
- 8 Radiator
- 9 Bypass hose

16951

## 2. Water Pump

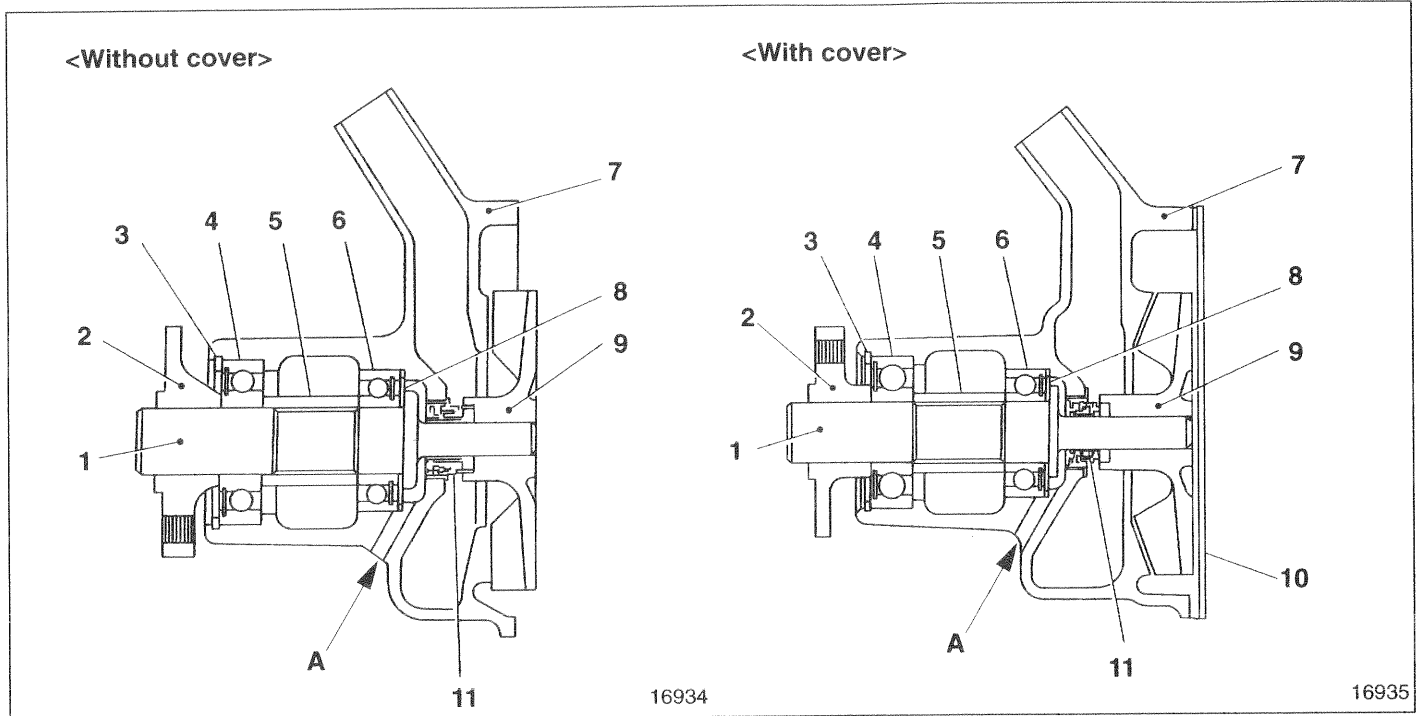

- 1 Water pump shaft
- 2 Flange
- 3 Snap ring
- 4 Bearing
- 5 Spacer
- 6 Bearing
- 7 Water pump case

- 8 Washer
- 9 Impeller
- 10 Cover
- 11 Unit seal

A: Drain hole

## 3. Thermostat

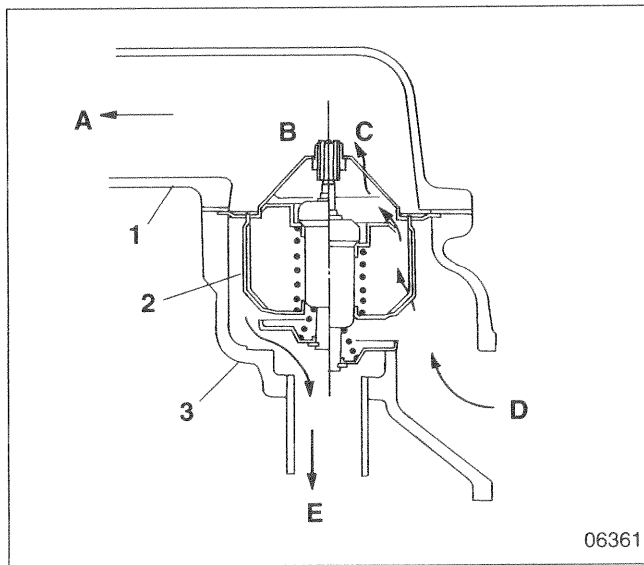

- 1 Thermostat cover
- 2 Thermostat
- 3 Thermostat case

- A: To radiator
- B: With low coolant temperature
- C: With high coolant temperature
- D: From cylinder head
- E: To water pump

Thermostat 2 is a bottom bypass type that uses wax-charged pellets as its regulating element. As the wax changes from solid to liquid in line with temperature increases, the total wax volume changes. As a result, the position of the valve, changed by the coolant temperature, regulates the flow of coolant to the radiator and water pump (bypass side) and controls the coolant temperature.

# TROUBLESHOOTING

Symptoms		Overheating (insufficient cooling)	Overcooling	Abnormal noise	Excessive coolant loss	Remarks
V-belt	Loose or damaged	<input type="radio"/>		<input type="radio"/>		
	Excessive tension			<input type="radio"/>		
	Oil on belt	<input type="radio"/>				
Water pump	Water pump fitted poorly	<input type="radio"/>			<input type="radio"/>	
	Gasket defective	<input type="radio"/>			<input type="radio"/>	
	Bearing defective	<input type="radio"/>		<input type="radio"/>		
	Impeller defective	<input type="radio"/>				
	Unit seal defective	<input type="radio"/>			<input type="radio"/>	
	Loose fit between shaft and flange and/or shaft and impeller	<input type="radio"/>		<input type="radio"/>		
Thermostat	Case fitted poorly	<input type="radio"/>			<input type="radio"/>	
	Gasket defective	<input type="radio"/>			<input type="radio"/>	
	Valve opening temperature too high; valve remains closed	<input type="radio"/>				
	Valve opening temperature too low; valve remains open		<input type="radio"/>			
	Water leaking from water temperature sensor	<input type="radio"/>			<input type="radio"/>	
Radiator	Space between core and fins clogged	<input type="radio"/>				
	Core cracked and/or separation of soldered joints	<input type="radio"/>			<input type="radio"/>	
	Pressure cap not sufficiently airtight	<input type="radio"/>				
Cooling fan	Fan shroud fitted poorly	<input type="radio"/>		<input type="radio"/>		
Automatic cooling fan coupling	Bearing defective	<input type="radio"/>		<input type="radio"/>		
	Bimetal damaged	<input type="radio"/>				
	Bimetal contaminated with foreign particles	<input type="radio"/>	<input type="radio"/>			
	Silicon oil leaking	<input type="radio"/>		<input type="radio"/>		
Oil cooler	Oil cooler fitted poorly	<input type="radio"/>			<input type="radio"/>	Gr 12
	Gasket defective	<input type="radio"/>			<input type="radio"/>	
Cylinder head	Cylinder head fitted poorly	<input type="radio"/>			<input type="radio"/>	Gr 11
	Gasket defective	<input type="radio"/>			<input type="radio"/>	
Coolant quantity insufficient and/or coolant dirty		<input type="radio"/>				
Coolant passages dirty and/or clogged		<input type="radio"/>				
Hoses fitted poorly		<input type="radio"/>			<input type="radio"/>	
Ambient temperature extremely low			<input type="radio"/>			

---

**M E M O**

---

# ON-VEHICLE INSPECTION AND ADJUSTMENT

## 1. Replacing Coolant and Cleaning Coolant System

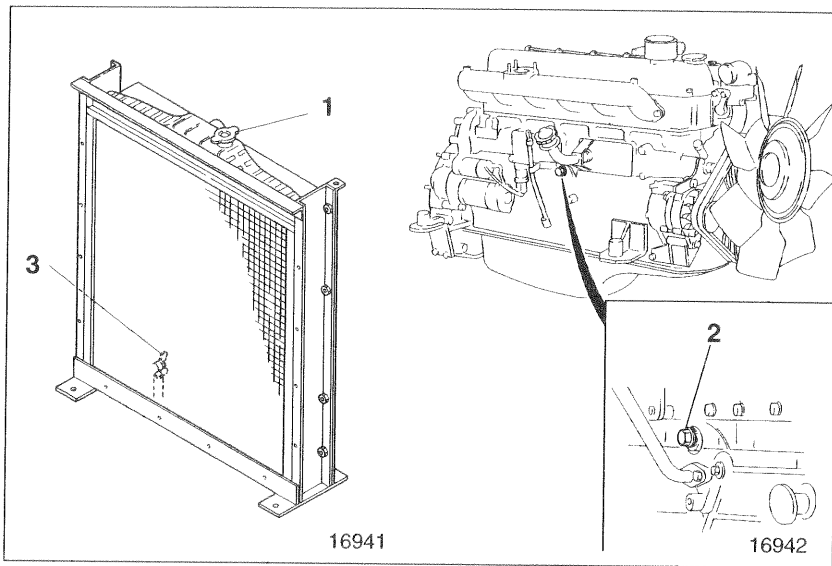

- 1 Pressure cap
- 2 Crankcase drain plug
- 3 Radiator drain cock

### ⓘ Tightening torques

Unit: N · m {kgf · m}

Location	Parts to be tightened	Tightening torque	Remarks
2	Crankcase drain plug	115 {12}	—

Using the radiator for extended periods without cleaning the cooling system will cause overheating since rust and scale deposits will accumulate. The cooling system must be cleaned periodically.

### ● Draining coolant

Before draining the coolant, loosen pressure cap 1 to reduce the pressure in the cooling system.

#### WARNING

- To avoid being scalded, ensure that the coolant has cooled sufficiently before draining it out.
- Unless care is exercised, opening pressure cap 1 when the coolant is hot can cause the coolant to spray out. Cover the pressure cap with a cloth, and loosen the cap slowly to bleed off the pressure before opening it fully.

### ● Cleaning procedure

- Run the engine and keep the coolant at a temperature of approximately 90°C so that the thermostat valve remains open and the coolant continues to circulate in the radiator.
- To increase the coolant temperature quickly, cover the front of the radiator with cardboard or a similar material.
- If cleaning is carried out after a large amount of rust has accumulated, the radiator may start to leak. Carefully examine the radiator for leaks after cleaning the cooling system.
- Soft water to be used should have the following properties.

#### CAUTION

Do not use hard water as it causes scale and rust.

Required properties of soft water

Total hardness	300 ppm or less	Total dissolved solids	500 ppm or less
Sulfate SO <sub>4</sub> <sup>-</sup>	100 ppm or less	pH	6 to 8
Chloride Cl <sup>-</sup>	100 ppm or less	—	—

Method of cleaning the cooling system depends on its condition.

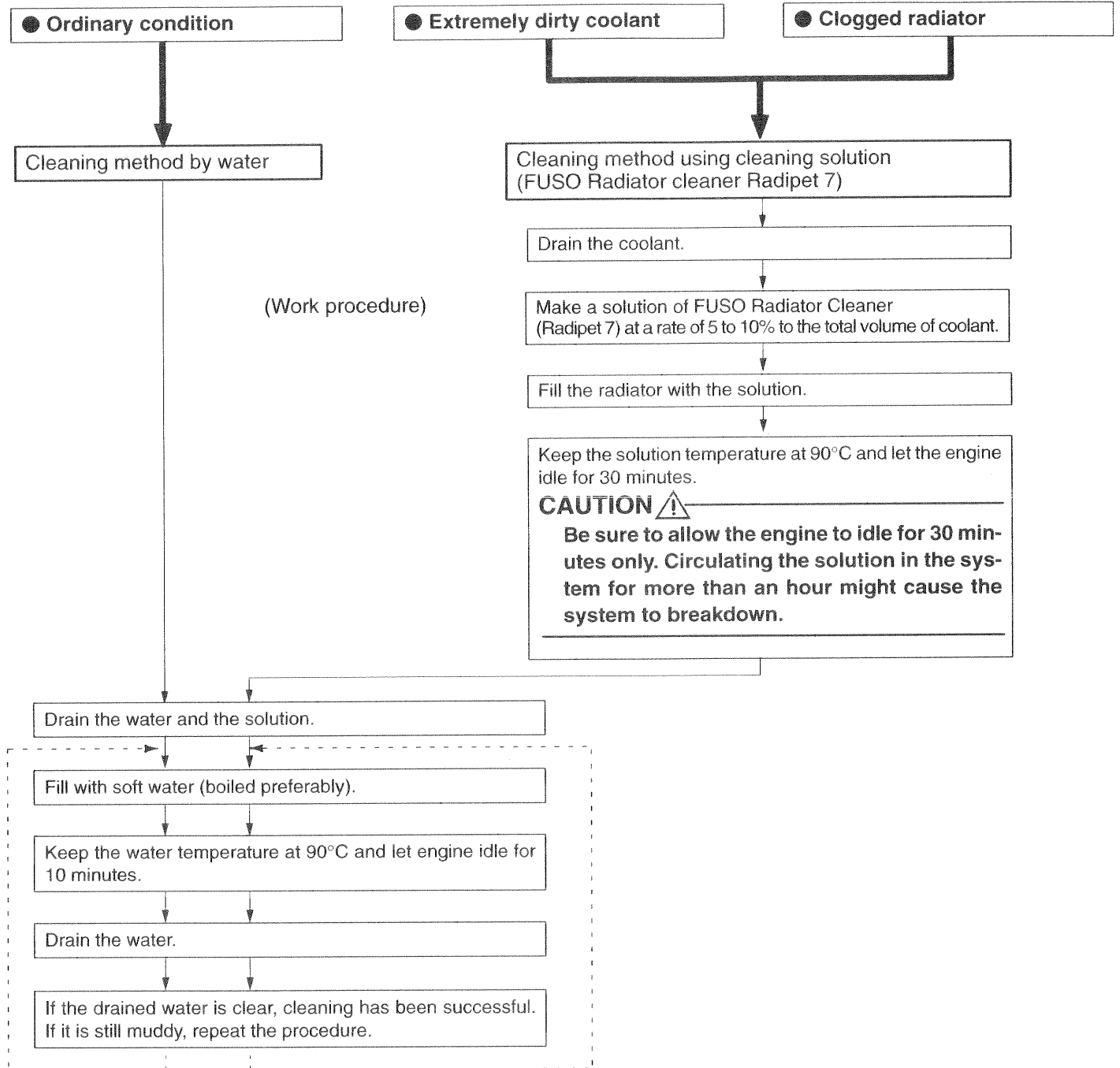

### DANGER ⚠

If you accidentally splash FUSO Diesel Long Life Coolant, Fuso Antifreeze, or Radiator Antirust (Radipet 9) in your eyes, wash it out immediately with water and seek medical attention.

### WARNING ⚠

FUSO Diesel Long Life Coolant is flammable. Keep them away from heat and flames.

### NOTE

- After cleaning the cooling system with cleaning fluid, fill it with coolant as soon as possible.
- To prevent freezing of the coolant and corrosion of the cooling system, add to the coolant the specified proportion of FUSO Diesel Long Life Coolant. (See the Maintenance Manual for instructions on the use of these products).

# ON-VEHICLE INSPECTION AND ADJUSTMENT

## 2. Air Bleeding of Cooling System

- Remove the pressure cap. Keeping the coolant temperature at 90°C, let the engine idle until the cooling system is completely bled of air. While the engine is idling, keep the heater controller's adjustment lever at its maximum-temperature position so that coolant flows freely in the heater piping.
- After bleeding the cooling system of air, add coolant to the radiator and reservoir tank as required.

## 3. Gas Leak Testing

The presence of air or exhaust gas in the coolant increases corrosion and rust in the cooling system. Check for air or exhaust gas in the coolant using the following procedure:

- Remove pressure cap 1.

### WARNING

**Make sure the coolant is sufficiently cool before loosening the pressure cap. If the coolant is hot, it will spray out.**

- Run the engine until the coolant temperature reaches approximately 90°C.
- If bubbles **A** appear continuously, there is air or exhaust gas in the coolant.
- If the coolant contains air, the cylinder head bolts, water pump mounting bolts, or hose connections may be loose. Alternatively, the hoses may be damaged.
- If the coolant contains exhaust gas, it is possible that the cylinder head gasket is damaged or that the cylinder head is cracked.

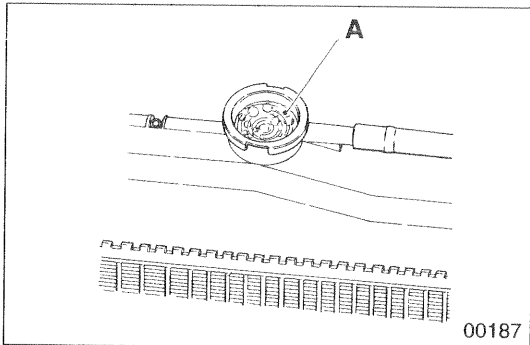

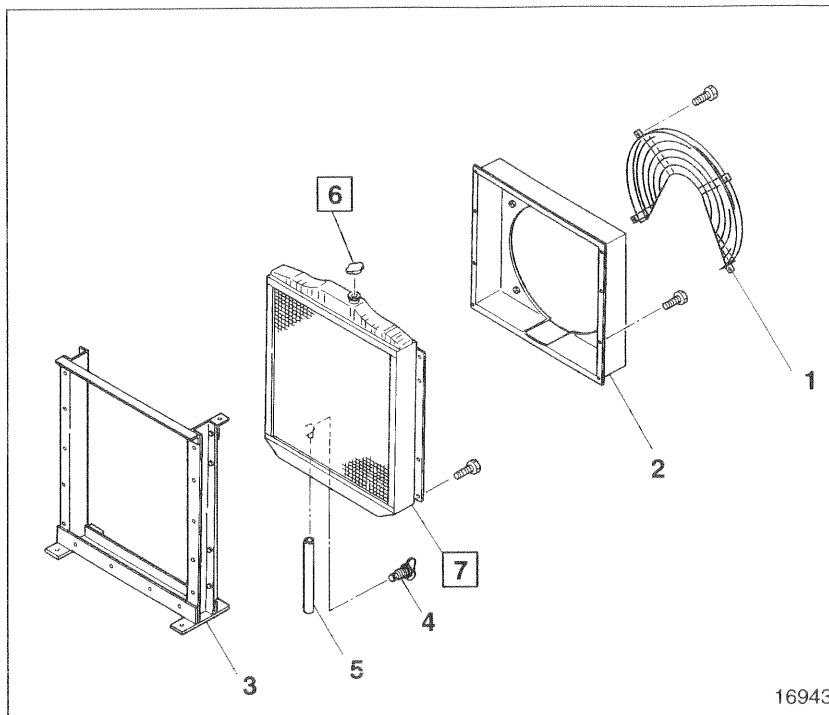

● **Disassembly sequence**

- 1 Wire net
- 2 Shroud
- 3 Frame
- 4 Drain cock
- 5 Drain hose
- 6 Pressure cap
- 7 Radiator

● **Assembly sequence**

Reverse the order of disassembly.

**Service standards**

Location	Maintenance item	Standard value	Limit	Remedy
6	Pressure valve opening pressure	69 ± 15 kPa {0.7 ± 0.15 kg/cm <sup>2</sup> }	—	Replace
7	Radiator air leakage (with air pressure of 150 kPa {1.5 kgf/cm <sup>2</sup> })	0 cc	—	Correct or replace

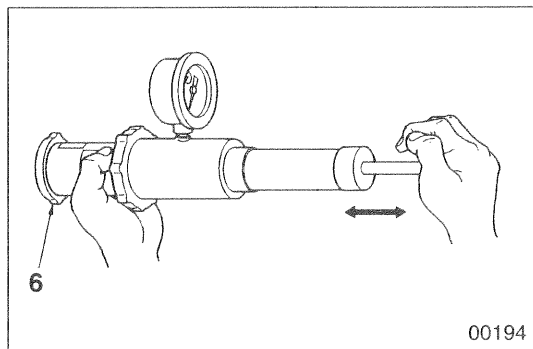

◆ **Service procedure**

**6** Pressure cap inspection

Measure the pressure valve's opening pressure. If the measurement does not conform with the standard value, replace pressure cap 6.

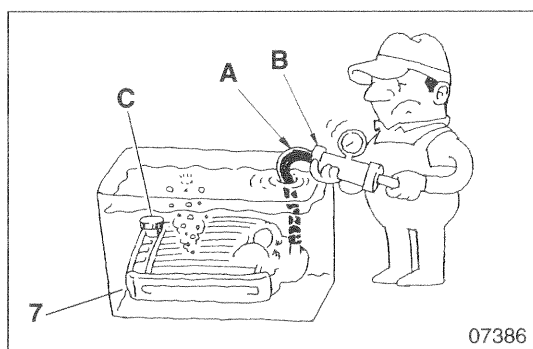

**7** Radiator inspection

- Fit hose A and radiator cap tester B to the radiator upper tank.
- Fit plug C to the lower tank, then immerse the radiator in a tank of water.
- Using radiator cap tester B, apply the specified air pressure of 150 kPa {1.5 kgf/cm<sup>2</sup>}, and check for air leakage.
- If air leakage is apparent, correct or replace radiator 7.

# COOLING FAN AND V-BELT

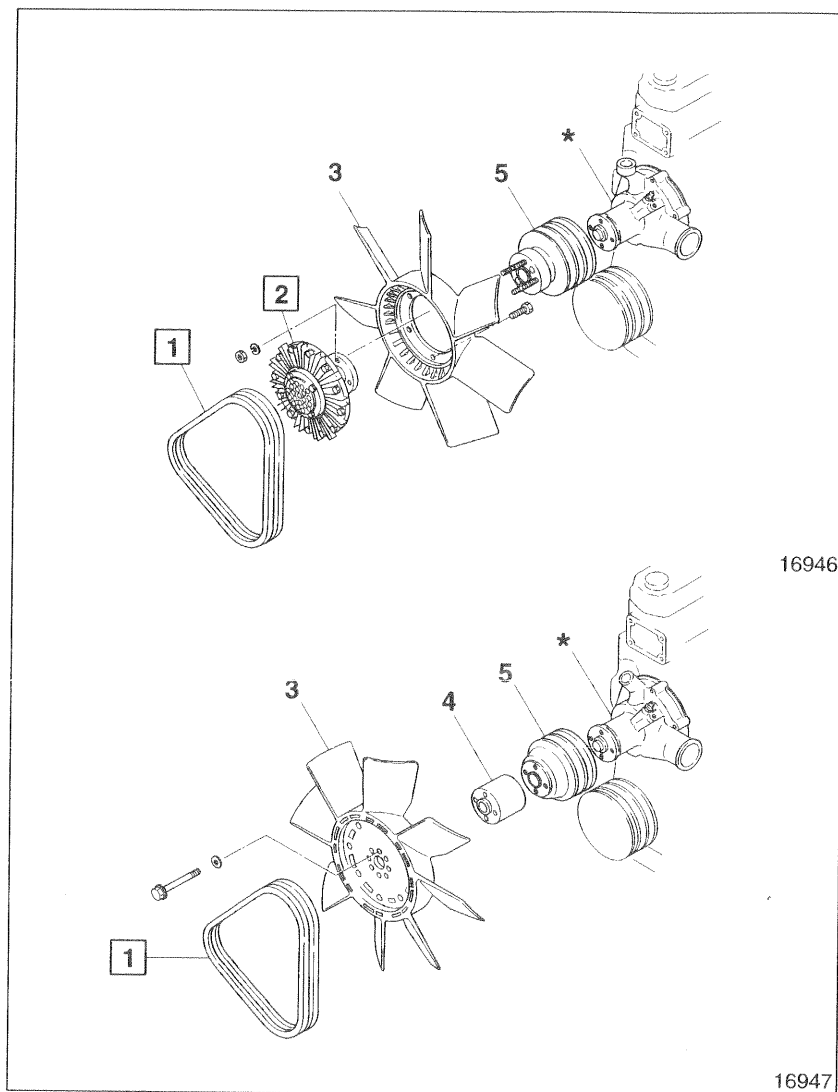

## ● Disassembly sequence

- 1 V-belt
- 2 Automatic cooling fan coupling
- 3 Cooling fan
- 4 Spacer
- 5 Water pump pulley

\*: Water pump assembly

📖 P.14-14

## ● Assembly sequence

Reverse the order of disassembly.

### CAUTION ⚠

- Automatic cooling fan coupling 2 is an integrated unit and cannot be disassembled. If any fault is apparent, replace the whole assembly.
- When replacing V-belts 1, be sure to replace them as a set to maintain even tension between them.

## Service standards

Unit: mm

Location	Maintenance item	Standard value	Limit	Remedy
1	V-belt tension	10 to 15	—	Adjust

## 🔧 Special tools

Location	Tool name and shape	Part No.	Application
1	Belt tension gauge  03612	MH062345	V-belt tension measurement

## ◆ Service procedure



### 1 V-belt

[Inspection]

Apply force of approximately 98 N {10 kgf} to the center of the V-belt 1 and measure the extent of V-belt deflection A.

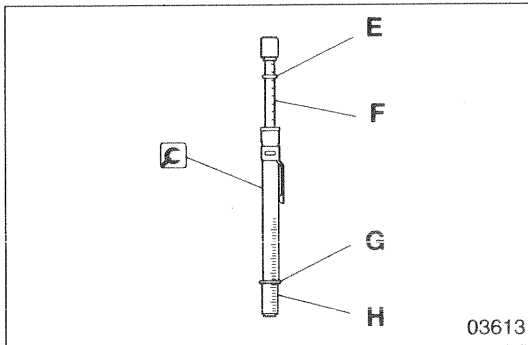
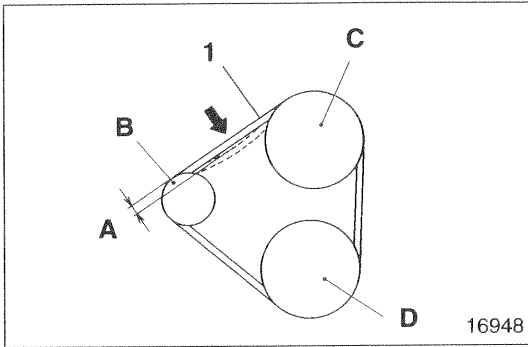
- B: Alternator pulley
- C: Water pump pulley
- D: Crankshaft pulley



- Set upper O-ring E of  belt tension gauge to 8 N {10 kgf} (push load) on scale F.
- Set lower O-ring G of  belt tension gauge to the V-belt's correct maximum deflection value on scale H.

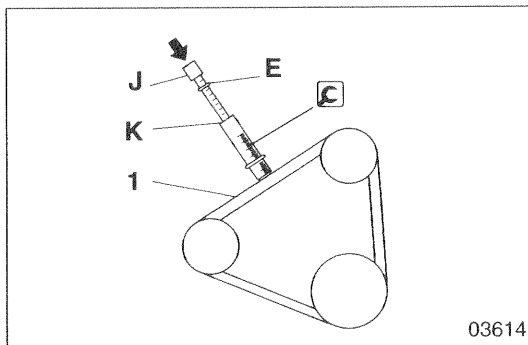

- Apply the  belt tension gauge to the center of V-belt 1 and push until O-ring E reaches the flange K.

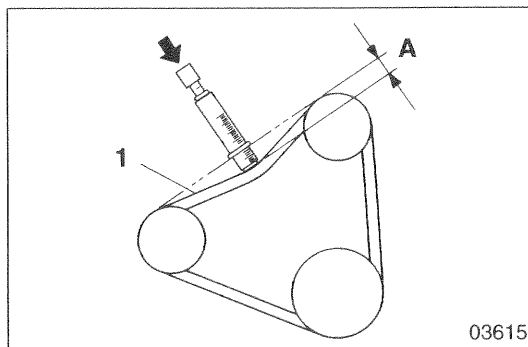

- Measure the extent of V-belt 1 deflection A. If the measurement does not conform with the standard value, adjust the V-belt as shown below.

# COOLING FAN AND V-BELT

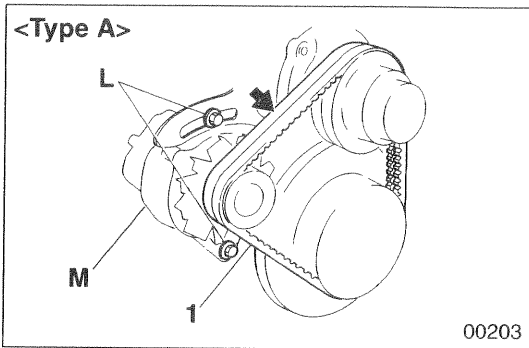

[Adjustment]

## CAUTION

- Excessive tension in V-belt 1 may damage the belt and related bearings.
- Be sure to replace the V-belts 1 as a set to maintain even tension between them.
- Keep V-belt 1 free of oil. If the belt becomes oily, it will slip, resulting in overheating of the engine and insufficient charging of the battery.

<Type A>

- Loosen alternator mounting bolts L (2 places) and adjust the V-belt tension by moving alternator M to the left or right.
- When the adjustment is complete, tighten the bolts and nuts securely.

<Type B>

- Loosen alternator retaining bolts L (2 places) and adjust the tension of V-belt 1 using adjuster bolt N.
- After the belt tension is adjusted, tighten the bolts and nut firmly.

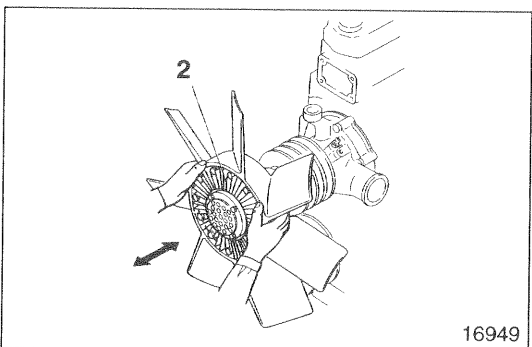
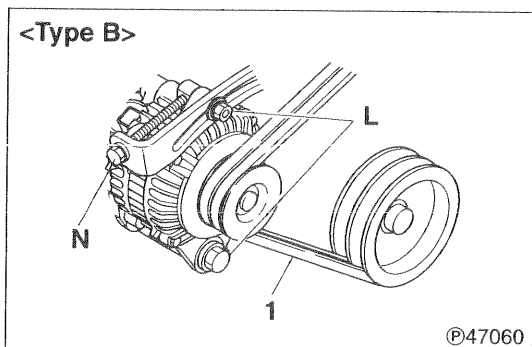

## 2 Automatic cooling fan coupling

[Inspection]

Inspect automatic cooling fan coupling 2 in accordance with the following procedure. If any defect is evident, replace the unit.

- Check for leakage of oil from the coupling body.
- Rotate automatic cooling fan coupling 2 by hand and check for irregular movement or abnormal noise caused by a defect in the bearing.
- Check for excessive axial play in automatic cooling fan coupling 2 when the engine is cool.

[Cleaning]

If any foreign particles have adhered to bimetal A, brush them off gently.

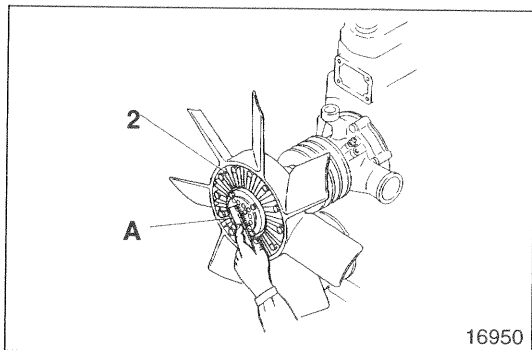

---

**M E M O**

---

# WATER PUMP

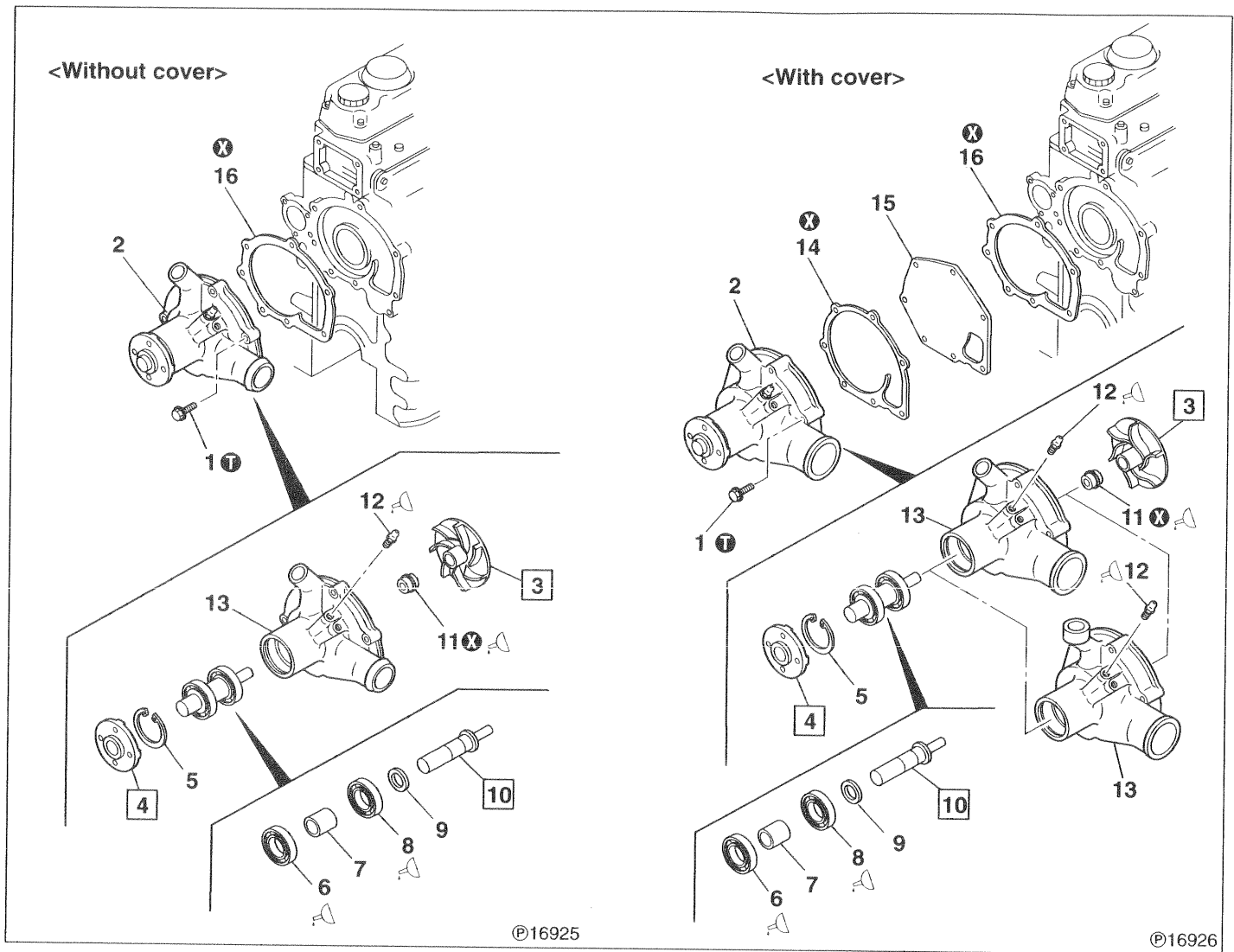

## ● Disassembly sequence

- 1 Bolt
- 2 Water pump assembly
- 3 Impeller
- 4 Flange
- 5 Snap ring
- 6 Bearing
- 7 Spacer
- 8 Bearing
- 9 Washer

- 10 Water pump shaft
- 11 Unit seal
- 12 Grease nipple
- 13 Water pump case
- 14 Gasket (pump with cover)
- 15 Cover (pump with cover)
- 16 Gasket

⊗ : Non-reusable part

## ● Assembly sequence

16 → 15 → 14 → 2 → 1

2 : 

13 → 12 → 5 → 11 → 4 → 3 10 → 9 → 8 → 7 → 6
--

## ● Inspection after assembly

📖 P.14-16

## Service standards

Unit: mm

Location	Maintenance item	Standard value (Basic diameter in [ ])	Limit	Remedy
3, 10	Impeller-to-water pump shaft interference	[13] 0.03 to 0.06	—	Reassembly allowed only twice
4, 10	Flange-to-water pump shaft interference	[26] 0.05 to 0.08	—	Reassembly allowed only twice

## Tightening torque

Unit: N · m {kgf · m}

Location	Parts to be tightened	Tightening torque	Remarks
1	Bolt (water pump assembly mounting)	9.8 {1.0}	—

## Lubricant and/or sealant

Location	Points of application	Specified lubricant and/or sealant	Quantity
6, 8	Bearings	Wheel bearing grease [NLGI No. 2 (Li soap)]	As required
11	Unit seal outer periphery	THREEBOND 1102	As required
12	Grease nipple	Wheel bearing grease [NLGI No. 2 (Li soap)]	60 g

## Special tools

Unit: mm

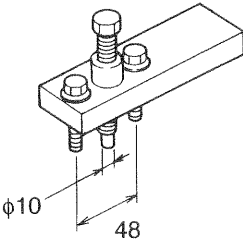
Location	Tool name and shape	Part No.	Application
3	Impeller Puller 	MH061417	Removing impeller

# WATER PUMP

## ◆ Service procedure

### ● Inspection after assembly

- After assembly, rotate flange 4 by hand and check that it turns smoothly without hindrance.
- If the flange does not turn smoothly, disassemble and inspect the water pump again.

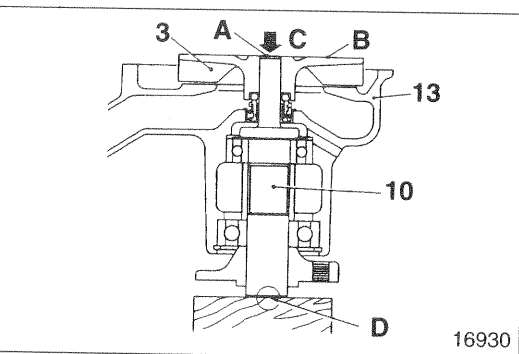
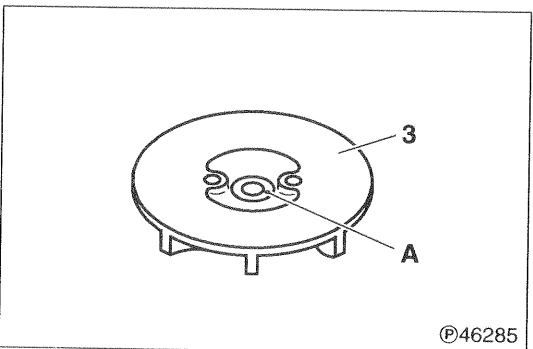
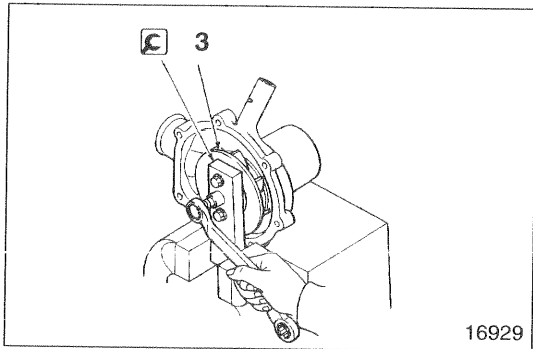
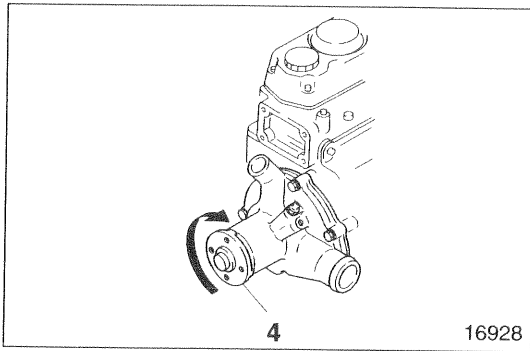

### 3 Impeller

[Removal]

 : Impeller Puller

[Installation]

### CAUTION

- Before refitting impeller 3, check the number of punch marks in location A shown in the illustration. If there is no or only one punch mark in location A, the impeller can be refitted. Ensure to punch a mark in location A for future reference before refitting the impeller.
- The punch mark is used to show how many times in the past impeller 3 is removed and refit. If there are two punch marks (i.e. removed and refit twice in the past), do not refit the impeller again. Replace it with a new impeller.

Press-fit impeller 3 until its end face B is in line with end face A of water pump shaft 10.

C: Press

### NOTE

Press-fit the impeller such that flange side D of water pump shaft 10 is the load receiving surface.

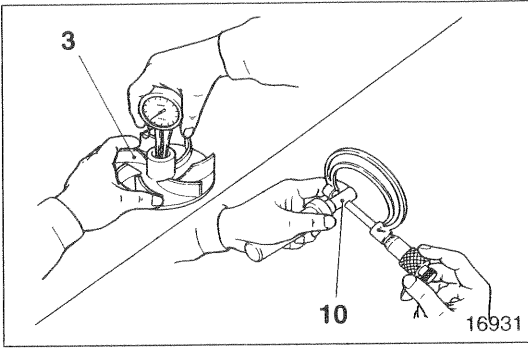

**3 10 Impeller-to-water pump shaft interference**

If the measurement does not conform with the standard value, replace the defective part(s).

**CAUTION** ⚠

Even if the standard value is satisfied, reassembly must not be carried out more than twice.

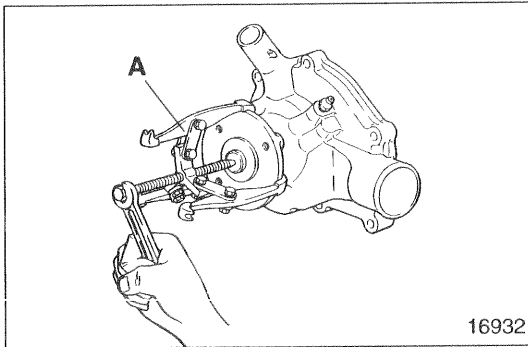

**4 Flange**

[Removal]

A: Gear puller

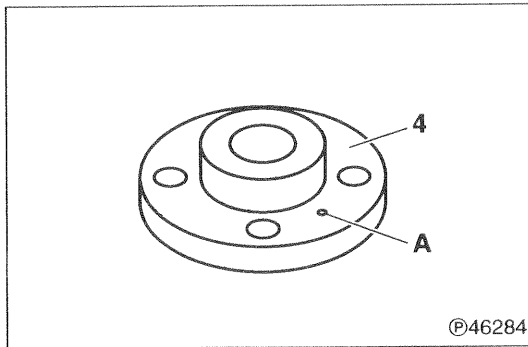

[Installation]

**CAUTION** ⚠

- Before refitting flange 4, check the number of punch marks in location A shown in the illustration. If there is no or only one punch mark in location A, the flange can be refitted. Ensure to punch a mark in location A for future reference before refitting the flange.
- The punch mark is used to show how many times in the past flange 4 is removed and refit. If there are two punch marks (i.e. removed and refit twice in the past), do not refit the flange again. Replace it with a new flange.

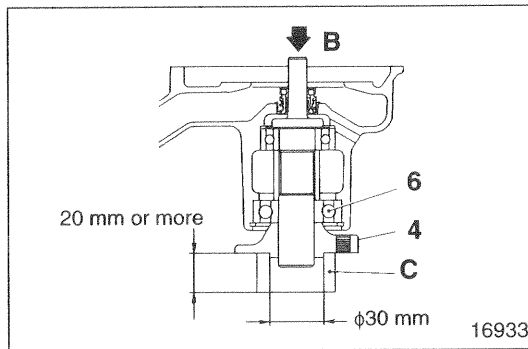

[Press-fitting]

With a load of 9,810 N {4,000 kgf}, press-fit flange 4 until it touches bearing 6.

B: Press  
C: Cylindrical jig

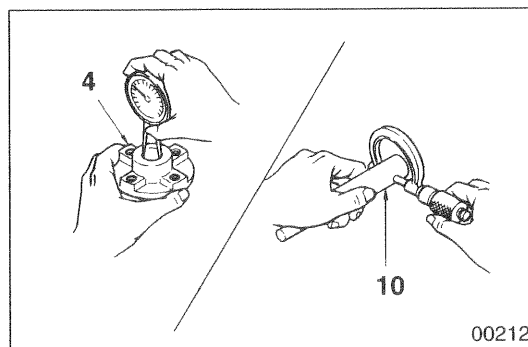

**4 10 Flange-to-water pump shaft interference**

If the measurement does not conform with the standard value, replace the defective part(s).

**CAUTION** ⚠

Even if the standard value is satisfied, reassembly must not be carried out more than twice.

# THERMOSTAT

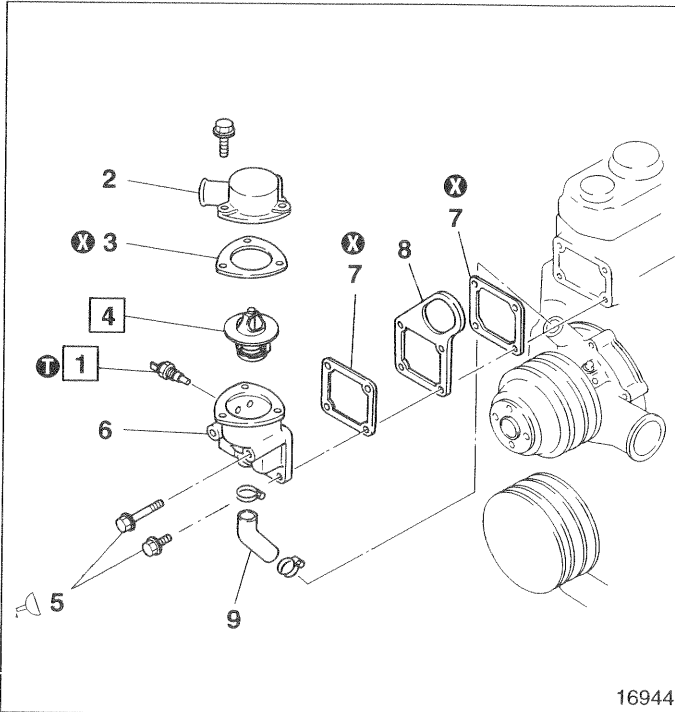

16944

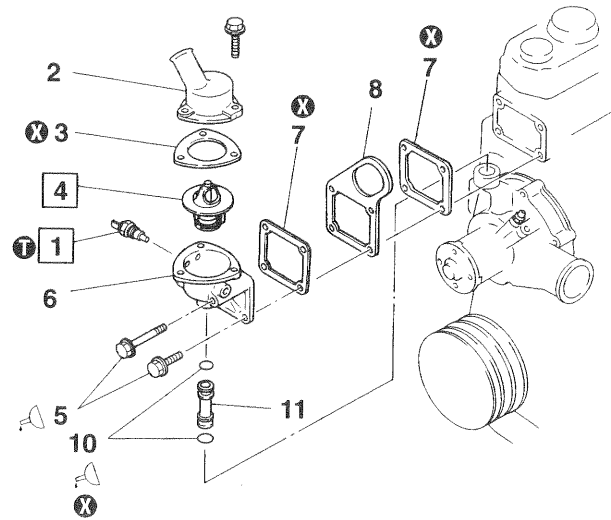

16945

## ● Disassembly sequence

- 1 Water temperature sensor
- 2 Thermostat cover
- 3 Gasket
- 4 Thermostat
- 5 Bolt
- 6 Thermostat case
- 7 Gasket

- 8 Front hanger
- 9 Bypass hose
- 10 O-ring
- 11 Joint

⊗ : Non-reusable part

## NOTE

Do not remove thermostat case 6 and front hanger 8 unless they are leaking water or otherwise defective.

## ● Assembly sequence

Reverse the order of disassembly.

## Service standards

Location	Maintenance item		Standard value	Limit	Remedy
1	Water temperature sensor resistance (Between terminal ① and body)	50°C	(136 Ω)	—	Replace
		80°C	48 ± 5 Ω	—	
		100°C	27.2 ± 2 Ω	—	
4	Thermostat	Valve opening temperature	76.5 ± 2°C	—	Replace
		Valve lift/temperature	10 mm or more at 90°C	—	

## ① Tightening torque

Unit: N·m {kgf·m}

Location	Parts to be tightened	Tightening torque	Remarks
1	Water temperature sensor	$34 \pm 6.9$ { $3.5 \pm 0.7$ }	—

## 🔧 Lubricant and/or sealant

Location	Points of application	Specified lubricant and/or sealant	Quantity
5	Threads of bolts (thermostat case mounting)	THREEBOND 2302	As required
10	Periphery of O-ring	Soapy water	As required

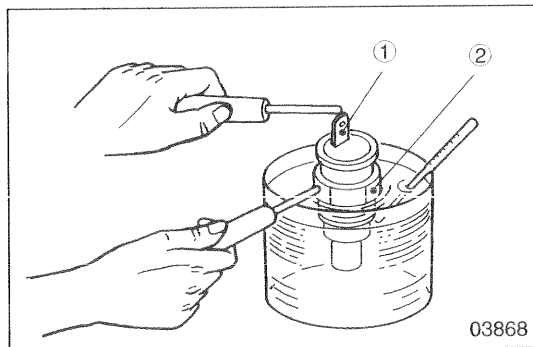

## ◆ Service procedure

### 1 Water temperature sensor inspection

- Place water temperature sensor 1 in a container of engine oil.
- Heat the oil until it reaches the specified temperatures. Stir the oil to ensure that it heats up evenly.
- Measure the resistance between terminal ① and body ② of the water temperature sensor.
- If the measurements do not conform with the specified values, replace the water temperature sensor 1.

### 4 Thermostat inspection

Place the thermostat in a container of water. While stirring the water with a rod A to ensure that it is heated evenly, carry out the following inspection procedure. If the measurements do not conform with the standard values, replace the thermostat 4.

#### (1) Valve opening temperature

- Support thermostat 4 with wire E to keep it away from heat source D.
- Gradually heat the water until it reaches the valve opening temperature.
- Maintain this temperature for 5 minutes and check that valve B is open.
- When the water temperature drops below 65°C, check that valve B is completely closed.

C: Thermometer

#### (2) Valve lift

Heat the water to slightly higher than the valve opening temperature. With valve B fully open, maintain this water temperature for 5 minutes. Measure the extent of valve lift F.

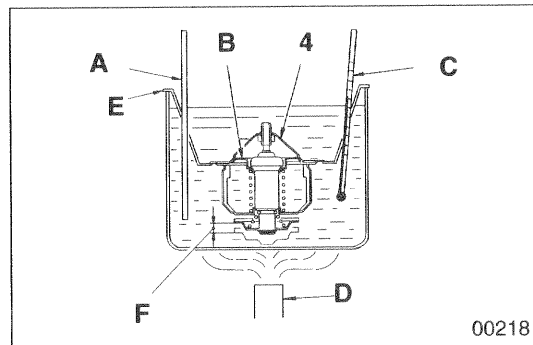



# GROUP 15 INTAKE AND EXHAUST

<b>SPECIFICATIONS</b> .....	<b>15-2</b>
<b>STRUCTURE AND OPERATION</b>	
1. Air Cleaner .....	15-3
2. Cartridge Type Air Cleaner .....	15-4
3. Pre-Cleaner .....	15-4
4. Dust Indicator .....	15-5
5. Turbo Charger .....	15-6
<b>TROUBLESHOOTING</b> .....	<b>15-9</b>
<b>ON-VEHICLE INSPECTION AND ADJUSTMENT</b>	
1. Inspection of Dust Indicator .....	15-10
<b>AIR CLEANER</b>	
<FHG, FWG> .....	15-12
<FTG> .....	15-16
<Cartridge> .....	15-19
<b>TURBOCHARGER</b>	
<T04B, T04E (6D16-TE)> .....	15-20
<T04E (6D16-TL), TBP4> .....	15-30
<TF07> .....	15-42
<b>INTERCOOLER</b>	
<6D16-TL, 16-TLE> .....	15-52
<b>INTAKE MANIFOLD</b>	
<6D14, 16, 16-E> .....	15-54
<6D14-T, 15-T, 16-T, 16-TE> .....	15-56
<6D16-TL> .....	15-58
<6D16-TLE> .....	15-60
<b>EXHAUST MANIFOLD</b>	
<6D14, 16, 16-E> .....	15-62
<6D14-T, 16-T, 16-TE, 16-TL, 16-TLE> .....	15-63
<6D14-T, 15-T, 16-T, 16-TE, 16-TL, 16-TLE> .....	15-64

# SPECIFICATIONS

## Air cleaner element

Item	Specifications	
Type	Cyclone type, filter paper type	Cartridge type, filter paper type
Manufacturer	Nihon Donaldson	

## Dust indicator

Item	Specifications
Type	Mechanical type
	Electrical type

## Turbocharger

Item	Specifications			
Type	T04B	T04E	TBP4	TF07
Manufacturer	Honeywell			Mitsubishi Heavy Industries

## Intercooler

Item	Specifications
Type	Tube & corrugated fin air cooled type

## 1. Air Cleaner

### Cyclone type air cleaner

<FHG, FWG>

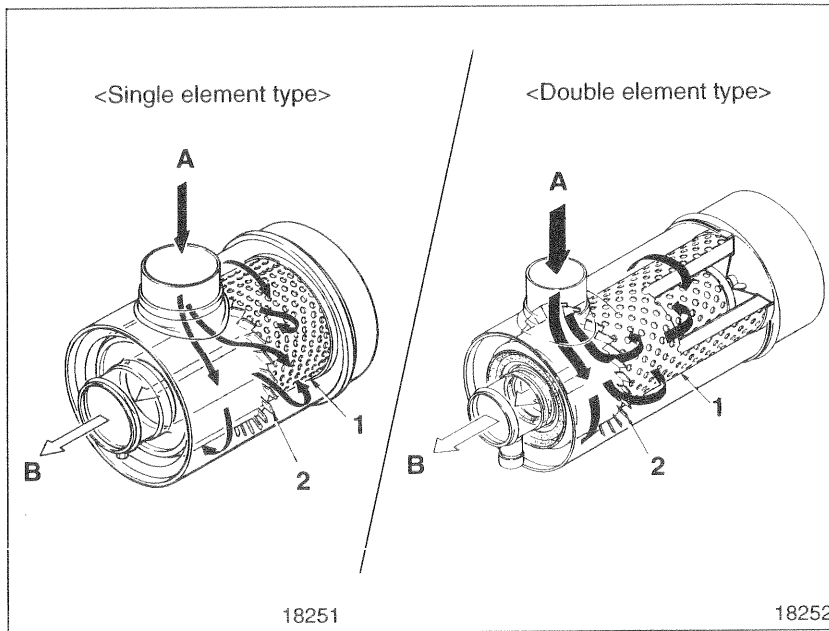

- 1 Element
- 2 Vane

A: Outside air  
B: To engine

The element 1, which comes in two types; the single and double element types, is the filter paper type. Coated with plastics and given heat treatment, the element offers outstanding resistance to water and oils.

The air that has been drawn in is made to rotate by the vane 2, and large particles of dust are centrifugally separated. Furthermore, small particles of dust are filtered out by the filter paper element, and the air thus made clean is drawn into the engine.

<FTG>

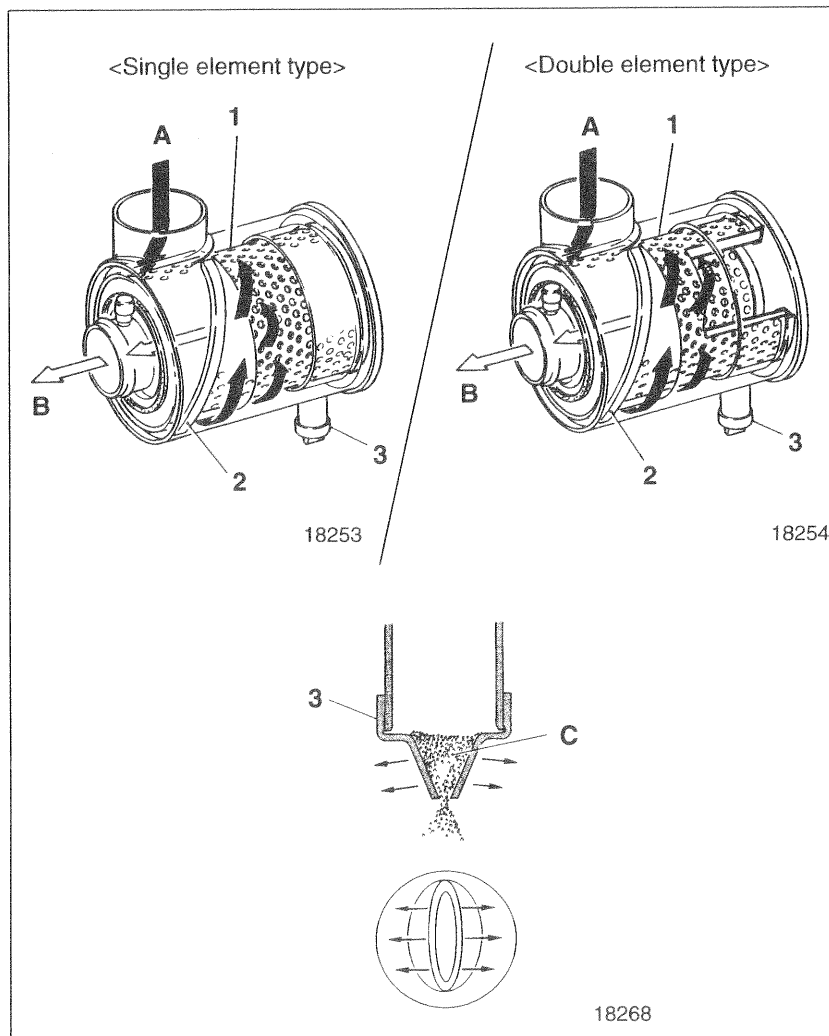

- 1 Element
- 2 Guide vane
- 3 Vacuator valve

A: Outside air  
B: To engine

The element 1, which comes in two types; the single and double element types, is the filter paper type. Coated with plastics and given heat treatment, the element offers outstanding resistance to water and oils.

The air that has been drawn in is made to rotate by the guide vane 2, and large particles of dust are centrifugally separated. Furthermore, small particles of dust are filtered out by the filter paper element, and the air thus made clean is drawn into the engine.

The vacuator valve 3 automatically discharges the separated dust and dirt. When the engine speed lowers to a certain speed, the elasticity of the rubber valve overcomes the negative pressure in the air cleaner, thus opens and discharges the dust and dirt C.

# STRUCTURE AND OPERATION

## 2. Cartridge Type Air Cleaner

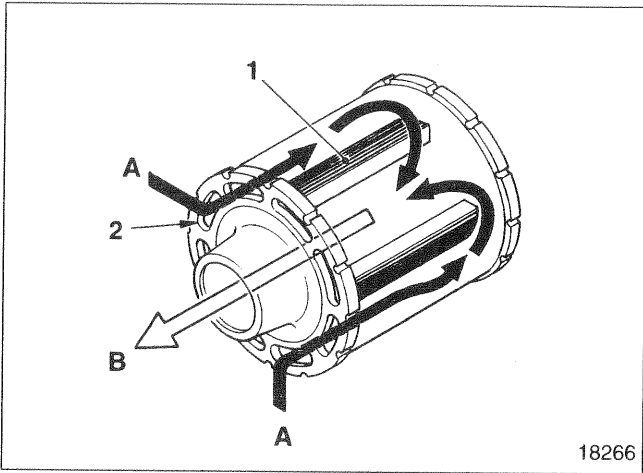

- 1 Element
- 2 Inlet slot

- A: Outside air
- B: Into engine

The element 1 is the filter paper type. The outside air is directly drawn in from the inlet slot 2 of the air cleaner proper.

## 3. Pre-Cleaner

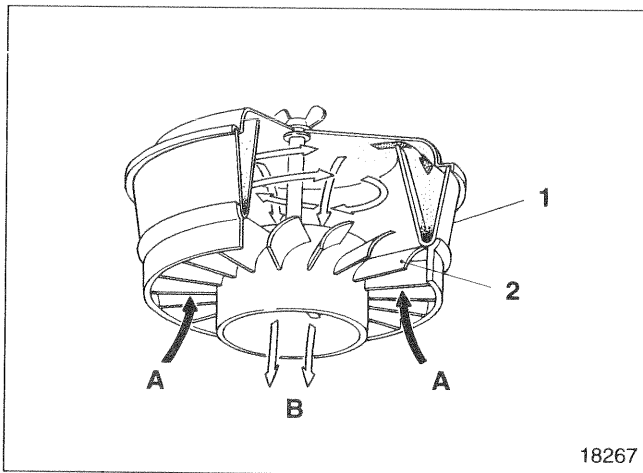

- 1 Pre-cleaner body
- 2 Guide vane

- A: Outside air
- B: To air cleaner

The pre-cleaner removes relatively large particles of dust contained in the air that has been drawn in. The air that has been drawn in is made to rotate by the guide vane 2 in the pre-cleaner, and the centrifugally separated particles of dust are accumulated in the pre-cleaner body 1.

## 4. Dust Indicator

### <Mechanical type>

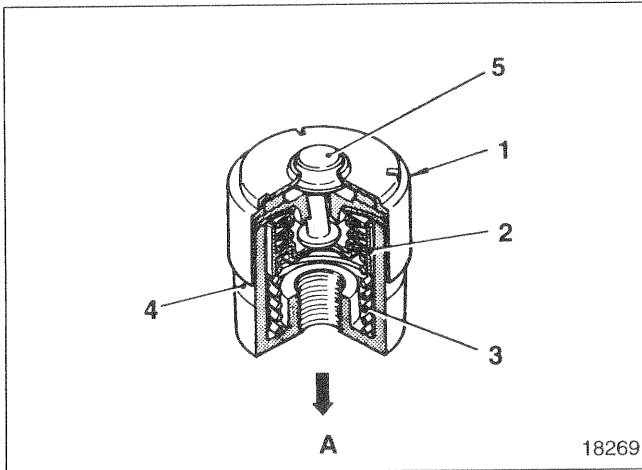

18269

- 1 Dust indicator
- 2 Signal
- 3 Spring
- 4 Transparent portion
- 5 Reset button

A: Negative pressure

The mechanical type dust indicator **1** is located near the intake air outlet of the air cleaner.

Operated by the negative pressure which is produced when the air is drawn into the engine, the dust indicator indicates that it is high time to clean or replace the element.

In other words, when the element is clogged with dust, the suction resistance increases. When the negative pressure **A** reaches 6.23 kPa {635 mmH<sub>2</sub>O}, the signal **2** (red) is pulled down against the spring pressure of the spring **3**. So the signal (red) appears in the transparent portion **4** of the body to indicate that it is high time to clean or replace the element.

After cleaning or replacing the element, press the reset button **5**, and the signal will return to its original position.

### <Electric type>

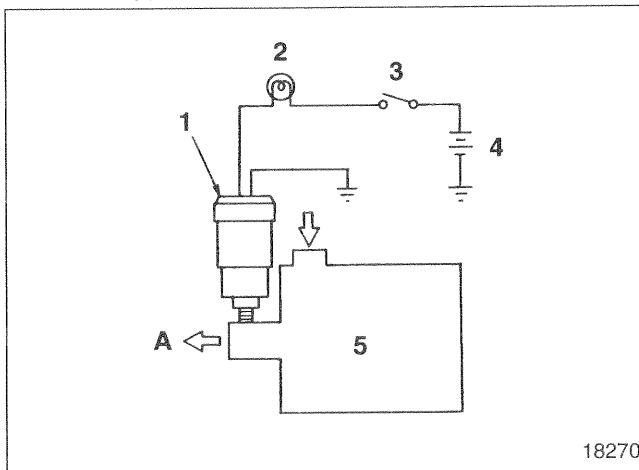

18270

- 1 Dust indicator
- 2 Warning lamp
- 3 Starter switch
- 4 Battery
- 5 Air cleaner

A: Negative pressure

When the negative pressure **A** reaches 6.23 kPa {635 mmH<sub>2</sub>O}, the electric type dust indicator closes its contact to light the warning lamp **2** and alert the driver that it is high time to clean or replace the element.

# STRUCTURE AND OPERATION

## 5. Turbo Charger

<T04B, T04E (6D16-TE)>

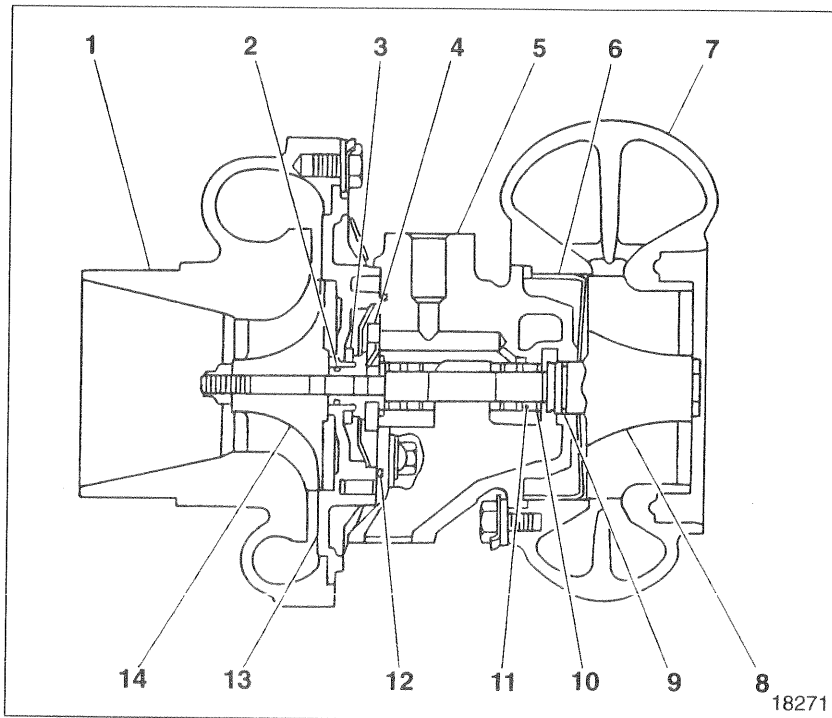

- 1 Compressor housing
- 2 Piston ring
- 3 Thrust collar
- 4 Thrust bearing
- 5 Center housing
- 6 Wheel shroud
- 7 Turbine housing
- 8 Turbine wheel
- 9 Piston ring
- 10 Retaining ring
- 11 Bearing
- 12 Seal ring
- 13 Back plate
- 14 Compressor wheel

<TF07>

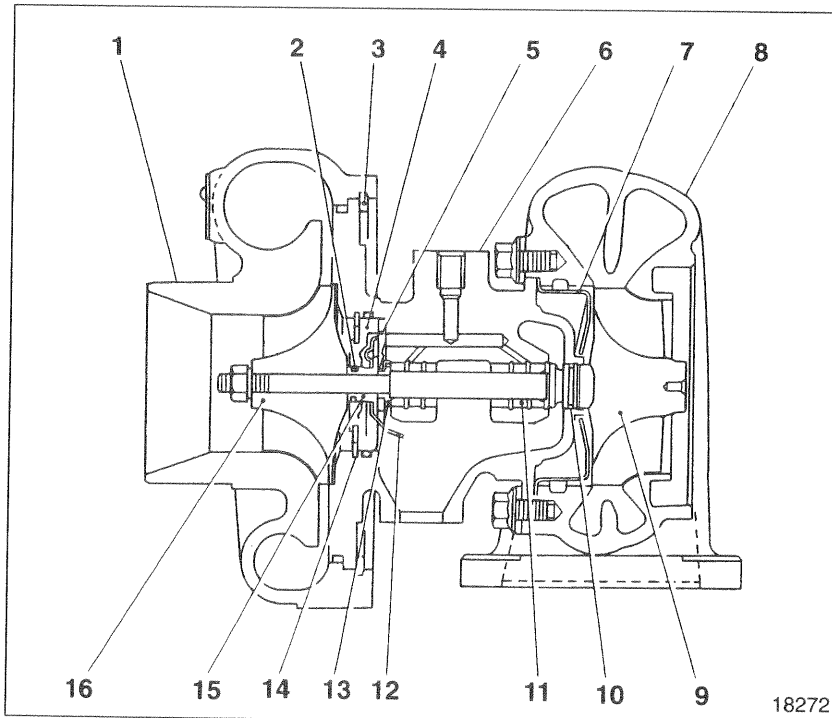

- 1 Compressor cover
- 2 Piston ring
- 3 Snap ring
- 4 Insert
- 5 Thrust bearing
- 6 Bearing housing
- 7 Turbine back plate
- 8 Turbine housing
- 9 Shaft & turbine wheel assembly
- 10 Piston ring
- 11 Bearing
- 12 Oil deflector
- 13 Thrust ring
- 14 Snap ring
- 15 Thrust sleeve
- 16 Compressor wheel

&lt;T04E (6D16-TL), TBP4&gt;

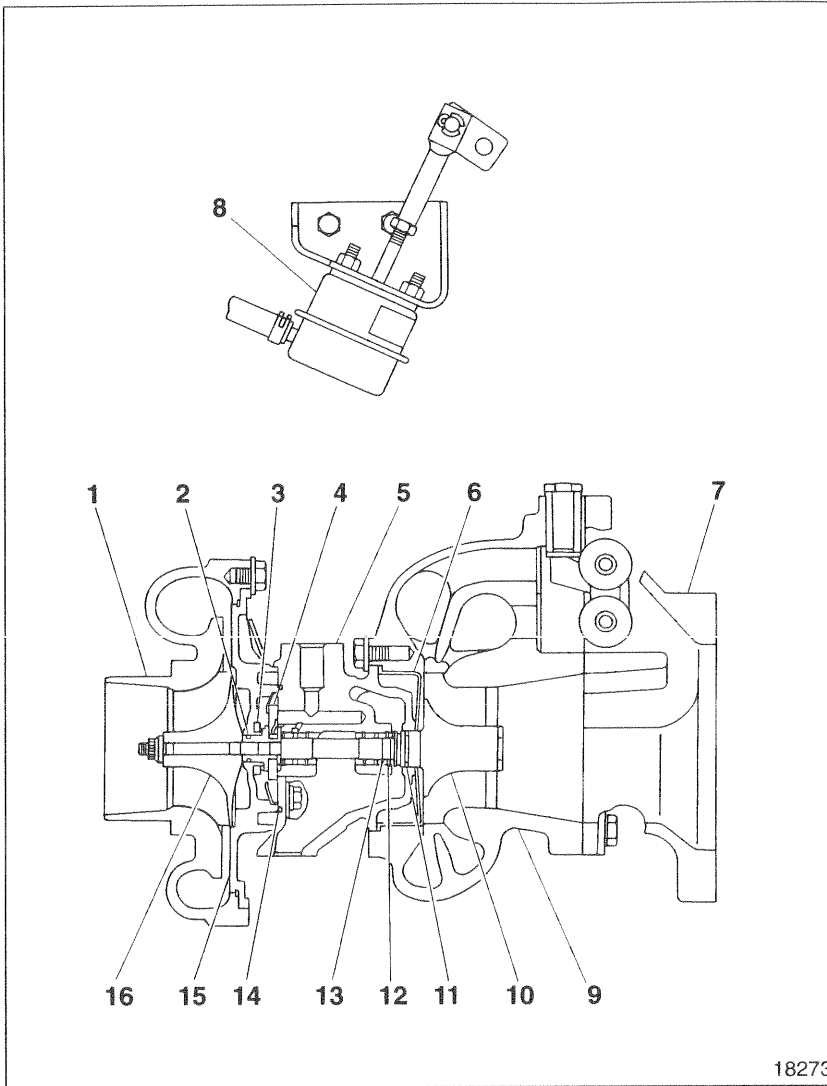

- 1 Compressor housing
- 2 Piston ring
- 3 Thrust collar
- 4 Thrust bearing
- 5 Center housing
- 6 Wheel shroud
- 7 Exhaust coupler
- 8 Actuator assembly
- 9 Turbine housing
- 10 Turbine wheel
- 11 Piston ring
- 12 Retaining ring
- 13 Bearing
- 14 Seal ring
- 15 Back plate
- 16 Compressor wheel

18273

# STRUCTURE AND OPERATION

## ● Waste gate mechanism <T04E (6D16-TL), TBP4>

- The waste gate mechanism has the actuator assembly **8** to let extra exhaust gas escape. By so doing, the boost pressure is properly controlled to prevent the turbine wheel from overrunning and prevent an excessive pressure produced in the intake manifold.
- The boost pressure is led from the compressor housing **1** through a rubber hose to the chamber **A** of the actuator assembly **8**. When the boost pressure that acts on the chamber **A** is below the setting, the actuator assembly does not operate, and the waste gate valve remains closed, and the exhaust gas **D** is blown against the turbine wheel **10**.

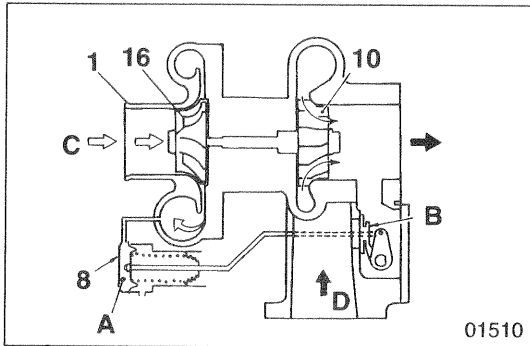

- When the boost pressure that acts on the chamber **A** exceeds the setting, the waste gate valve is opened. As a result, the amount of exhaust gas blown against the turbine wheel **10** decreases, and the rotating speed of the compressor wheel **16** also decreases, and the boost pressure falls.

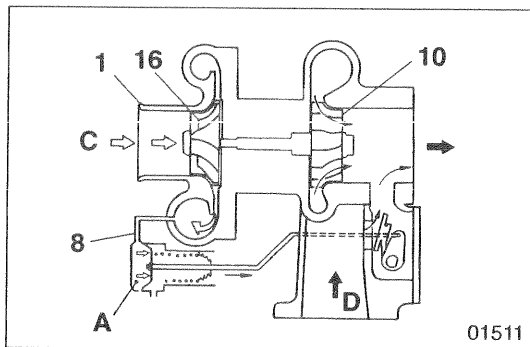

## ● Operation of overboost valve

- The overboost valve **E** operates when the boost pressure becomes abnormally high due to the failure of the waste gate mechanism.

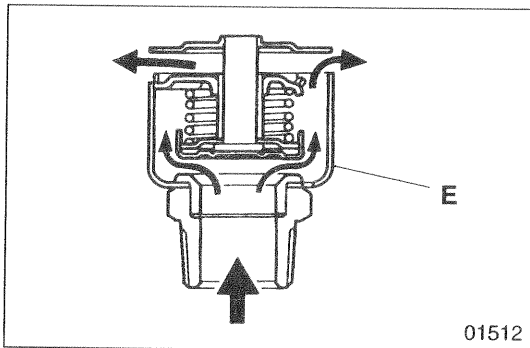

- When the boost pressure **F** of the overboost valve **E** exceeds the setting, the valve releases the boost pressure into the atmosphere to make sure that a boost pressure more than necessary is not applied to the engine.

The valve whistles when it is in operation.

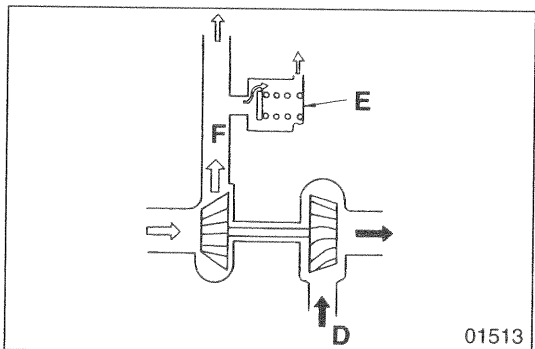

Possible causes		Symptoms						Remarks
		Engine hard to start	Black exhaust gas	White exhaust gas	Insufficient engine output	Excessive oil consumption	Strange sound or vibration in intake and exhaust system	
Air cleaner	Clogged air cleaner element	<input type="radio"/>	<input type="radio"/>		<input type="radio"/>			
Turbocharger	Defective bearing		<input type="radio"/>		<input type="radio"/>		<input type="radio"/>	
	Carbon deposited on turbine wheel		<input type="radio"/>		<input type="radio"/>			
	Turbine wheel interfering with wheel shroud and turbine back plate		<input type="radio"/>		<input type="radio"/>		<input type="radio"/>	
	Turbine wheel interfering with turbine housing		<input type="radio"/>		<input type="radio"/>		<input type="radio"/>	
	Bent turbine wheel		<input type="radio"/>		<input type="radio"/>		<input type="radio"/>	
	Damaged turbine wheel		<input type="radio"/>		<input type="radio"/>		<input type="radio"/>	
	Compressor wheel interfering with compressor housing		<input type="radio"/>		<input type="radio"/>		<input type="radio"/>	
	Thrust sleeve, thrust collar and thrust bearing seizure		<input type="radio"/>		<input type="radio"/>		<input type="radio"/>	
	Damaged compressor wheel		<input type="radio"/>		<input type="radio"/>		<input type="radio"/>	
	Oil leaks due to worn piston ring and insert			<input type="radio"/>		<input type="radio"/>		
	Improperly mounted piston ring					<input type="radio"/>		
	Unsmooth sliding of internal parts due to clogged lubrication oil pipe and eyebolt		<input type="radio"/>		<input type="radio"/>			
	Damaged oil seals due to clogged oil return pipe			<input type="radio"/>		<input type="radio"/>		
	Improperly mounted compressor housing		<input type="radio"/>		<input type="radio"/>	<input type="radio"/>	<input type="radio"/>	
Improperly mounted turbine housing				<input type="radio"/>		<input type="radio"/>		
Intercooler	Foreign substances deposited on front core of intercooler				<input type="radio"/>			
Deformed front pipe, muffler, tail pipe						<input type="radio"/>		
Improperly mounted front pipe, muffler, tail pipe						<input type="radio"/>		
Incorrect valve clearance			<input type="radio"/>					📖 Gr 11
Defective head gasket			<input type="radio"/>					📖 Gr 11
Worn valve and valve seat and deposited carbon			<input type="radio"/>					📖 Gr 11
Sagging valve spring			<input type="radio"/>					📖 Gr 11
Worn or damaged piston ring				<input type="radio"/>		<input type="radio"/>		📖 Gr 11
Worn or damaged piston ring groove of piston				<input type="radio"/>		<input type="radio"/>		📖 Gr 11
Malfunctioning cooling equipment			<input type="radio"/>					📖 Gr 14
Excessive engine oil				<input type="radio"/>				📖 Gr 12
Seizure of major moving parts			<input type="radio"/>					📖 Gr 11
Uneven or excessive fuel injection			<input type="radio"/>					📖 Gr 13

# ON-VEHICLE INSPECTION AND ADJUSTMENT

## 1. Inspection of Dust Indicator

### Service standards

Location	Maintenance item	Standard value	Limit	Remedy
—	Negative pressure for operation of dust indicator	$6.23 \pm 0.57$ kPa { $635 \pm 58$ mmH <sub>2</sub> O}	—	—

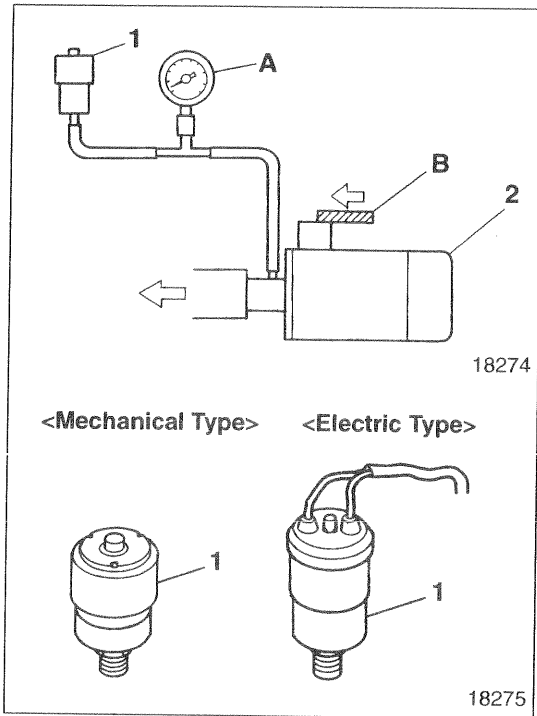

- Before checking the dust indicator **1**, clean or replace the air cleaner element.
- Start the engine, and cover the inlet of the air cleaner through use of a wooden block **B** in such a way that the negative pressure of the dust indicator **1** will have the nominal value and check that the mechanical type will show the red signal or the electric type will light the warning lamp. If there is anything wrong in operation, replace defective parts.

**2** Air cleaner

**A**: Negative pressure gauge

---

**M E M O**

---

# AIR CLEANER <FHG, FWG>

## <FHG Single Element Type>

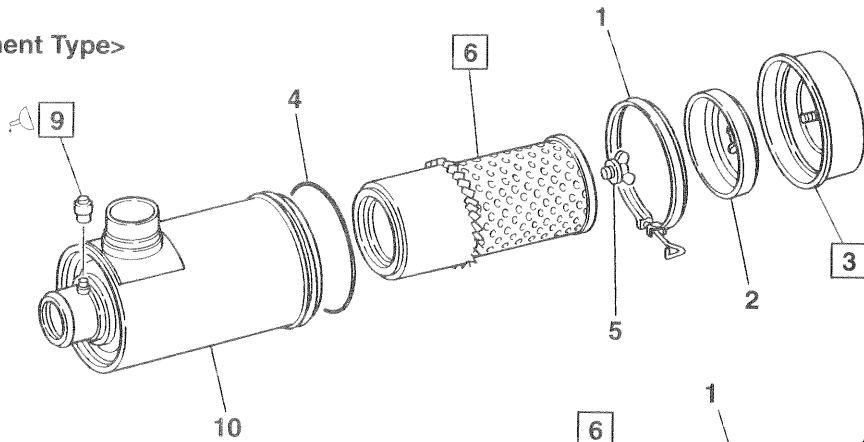

18276

## <FHG Double Element Type>

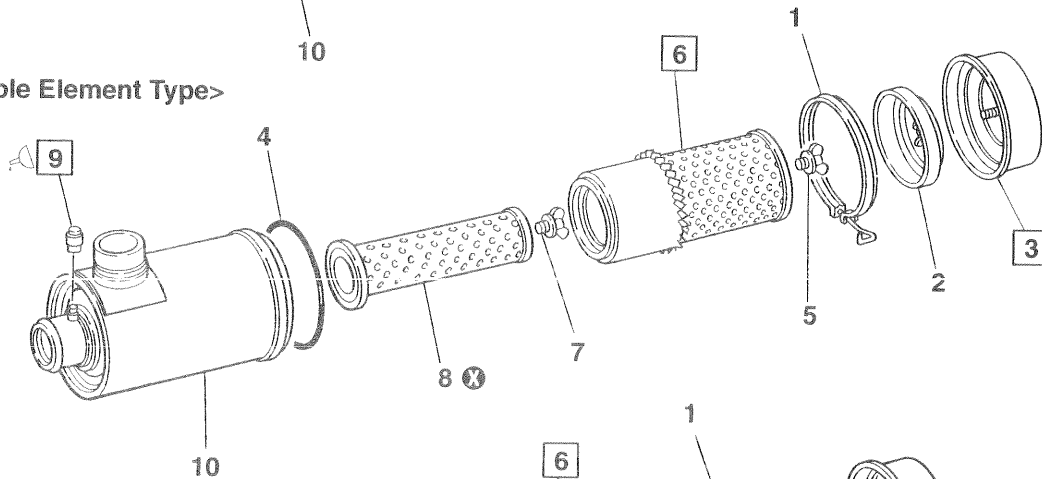

18277

## <FWG >

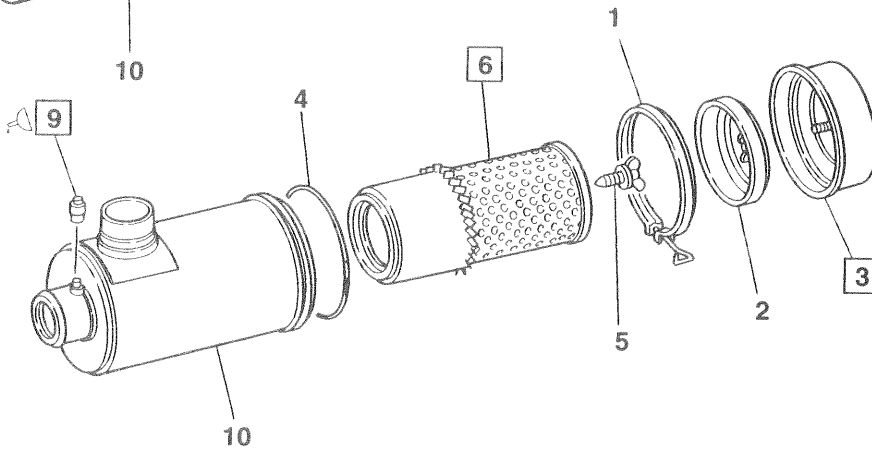

18278

### ● Disassembly sequence

- |   |  |
|---|--|
| 1 Clamp                                 | 7 Nut gasket <FHG double element type>     |
| 2 Baffle                                | 8 Safety element <FHG double element type> |
| 3 Dust cup                              | 9 Dust indicator                           |
| 4 O-ring                                | 10 Air cleaner body                        |
| 5 Nut gasket <FHG><br>Bolt gasket <FWG> |  |
| 6 Element                               |  |

⊗ : Non-reusable part

### NOTE

Do not disassemble the safety element 8 except when it need be replaced.

### ● Reassembly sequence

Reverse the order of disassembly.

## Service standards

Location	Maintenance item	Standard value	Limit	Remedy
9	Negative pressure for operation of dust indicator	$6.23 \pm 0.57$ kPa { $635 \pm 58$ mmH <sub>2</sub> O}	—	Replace

## Sealant

Location	Points of application	Specified sealant	Quantity
9	Apply to threads of dust indicator	ThreeBond 1401B	As required

## ◆ Service procedure

### 3 Dust cup

Reassemble the dust cup 3 with the arrow mark **A** toward the inlet **B**.

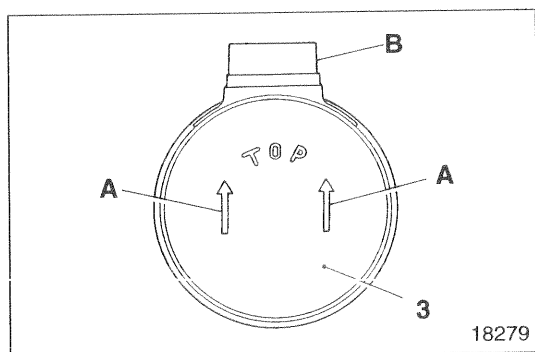

### 6 Element

#### [Cleaning]

- Blow compressed air 685 kPa {7 kg/cm<sup>2</sup>} or less from inside the element 6.
- Blow the compressed air, working along the creases of filter paper of the element 6 up and down throughout the element.

#### CAUTION ⚠

- Do not strike the element 6 to loosen dust.
- Do not blow the air from outside the element 6.

#### [Inspection]

- Put a light inside the element 6.
- If the filter paper is broken or partially thin, or if the packing on the top of the element 6 is broken, replace the element.
- If the dust deposited on the element 6 is wet with oil smoke or soot, replace the element irrespective of the replacement intervals.

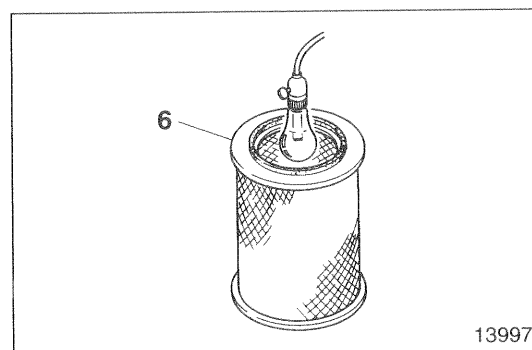
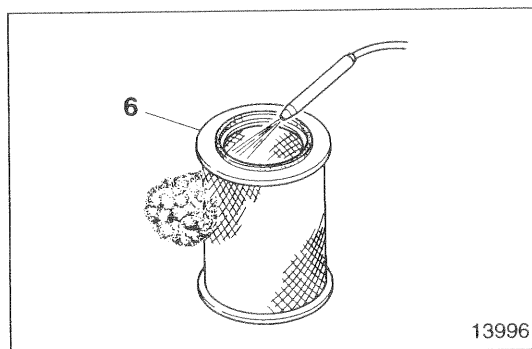

## 9 Inspection of dust indicator

Perform the following checks. If there is anything wrong, replace the dust indicator.

### <Mechanical type>

- Mount a hand vacuum pump **A** on the dust indicator **9** and apply the standard operating negative pressure to check whether the red signal appears.

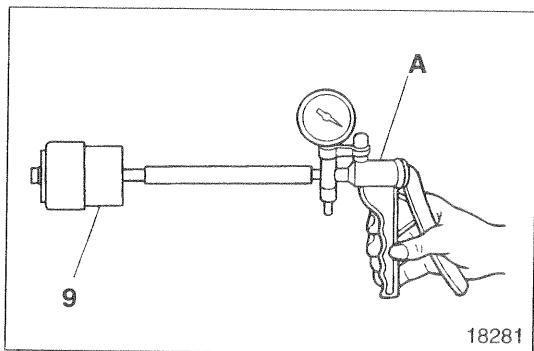

### <Electric type>

- Mount a hand vacuum pump **A** on the dust indicator **9** and apply the standard operating negative pressure to check that there is continuity between terminals ① and ②.
- Check that when there is no negative pressure applied to the dust indicator **9**, there is no continuity between the terminals ① and ②.

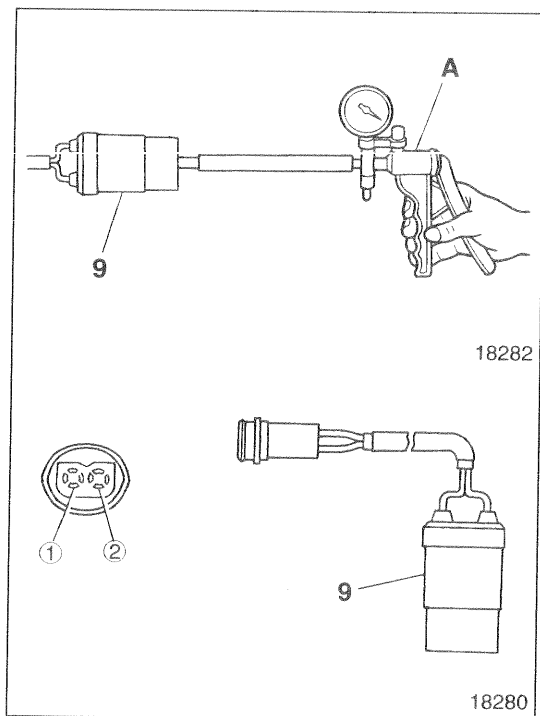

---

**MEMO**

---

# AIR CLEANER <FTG>

## <Single Element Type>

### <Type A>

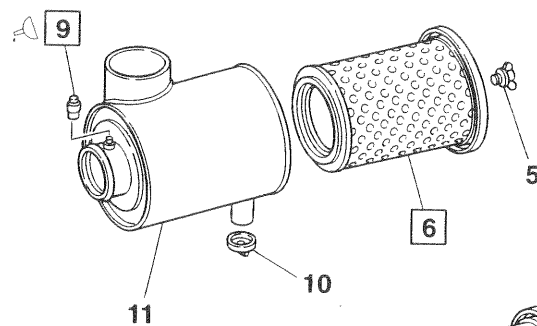

18283

### <Type B>

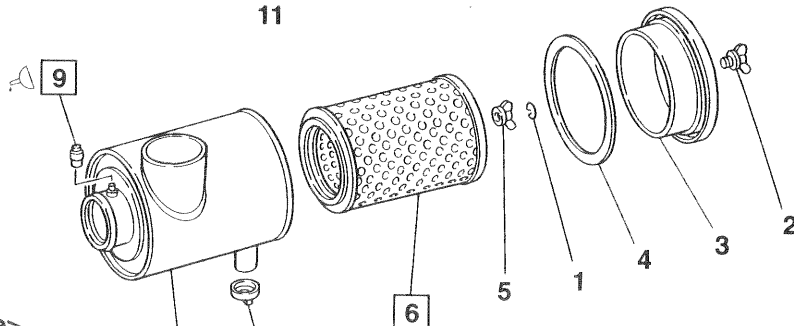

18284

## <Double Element Type>

### <Type A>

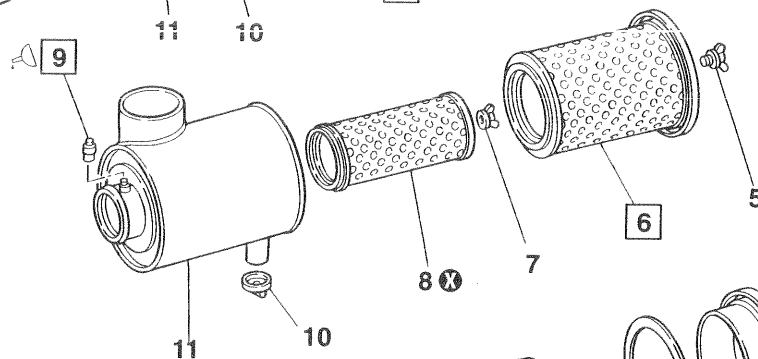

18285

### <Type B>

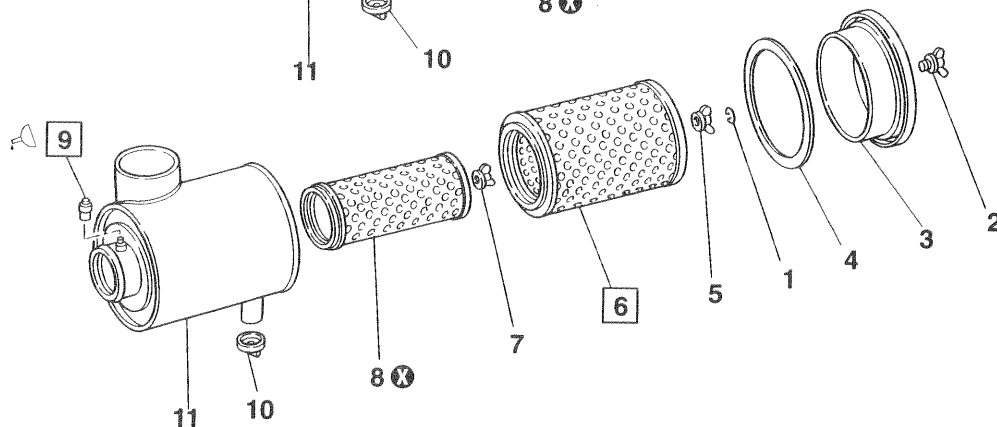

18286

## ● Disassembly sequence

- |                                    |  |
|------------------------------------|--|
| 1 Clip <Type B>                    | 8 Safety element <Double element type> |
| 2 Wing nut <Type B>                | 9 Dust indicator                       |
| 3 Cover <Type B>                   | 10 Vacuator valve                      |
| 4 Gasket <Type B>                  | 11 Air cleaner body                    |
| 5 Nut gasket                       |  |
| 6 Element                          |  |
| 7 Nut gasket <Double element type> |  |

⊗: Non-reusable part

## NOTE

Do not disassemble the safety element 8 except when it need be replaced.

## ● Reassembly sequence

Reverse the order of disassembly.

## Service standards

Location	Maintenance item	Standard value	Limit	Remedy
9	Negative pressure for operation of dust indicator	$6.23 \pm 0.57$ kPa { $635 \pm 58$ mmH <sub>2</sub> O}	—	Replace

## Sealant

Location	Points of application	Specified sealant	Quantity
9	Apply to threads of dust indicator	ThreeBond 1401B	As required

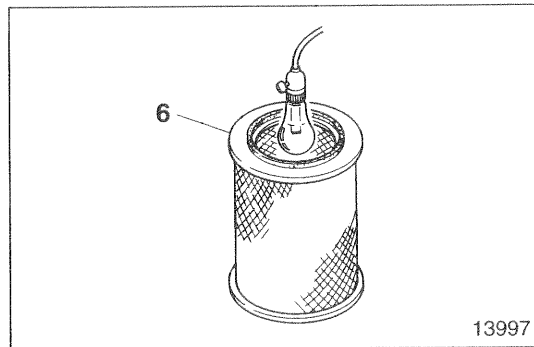
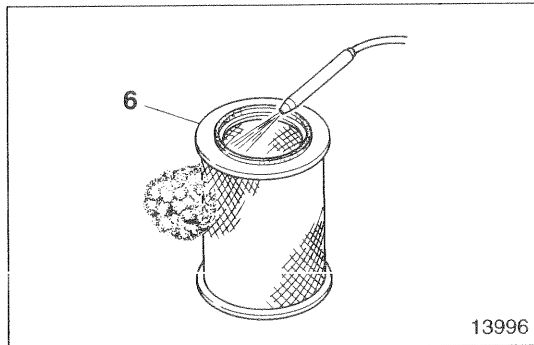

## ◆ Service procedure

### 6 Element

[Cleaning]

- Blow compressed air 685 kPa {7 kg/cm<sup>2</sup>} or less from inside the element 6.
- Blow the compressed air, working along the creases of filter paper of the element 6 up and down throughout the element.

### CAUTION

- Do not strike the element 6 to loosen dust.
- Do not blow the air from outside the element 6.

[Inspection]

- Put a light inside the element 6.
- If the filter paper is broken or partially thin, or if the packing on the top of the element 6 is broken, replace the element.
- If the dust deposited on the element 6 is wet with oil smoke or soot, replace the element irrespective of the replacement intervals.

### 9 Inspection of dust indicator

Perform the following checks. If there is anything wrong, replace the dust indicator.

<Mechanical type>

- Mount a hand vacuum pump A on the dust indicator 9 and apply the standard operating negative pressure to check whether the red signal appears.

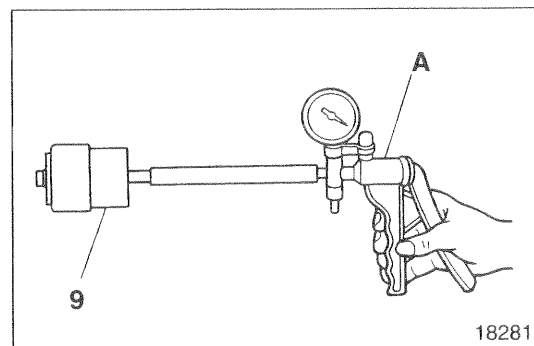

# AIR CLEANER <FTG>

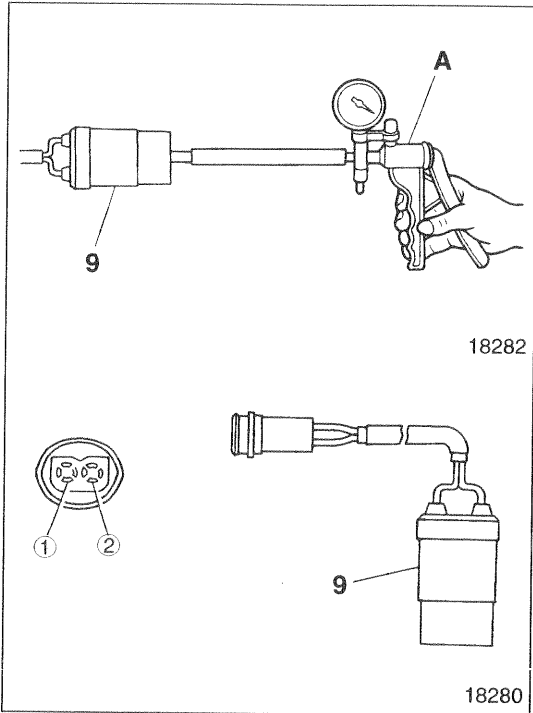

## <Electric type>

- Mount a hand vacuum pump **A** on the dust indicator **9** and apply the standard operating negative pressure to check that there is continuity between terminals ① and ②.
- Check that when there is no negative pressure applied to the dust indicator **9**, there is no continuity between the terminals ① and ②.

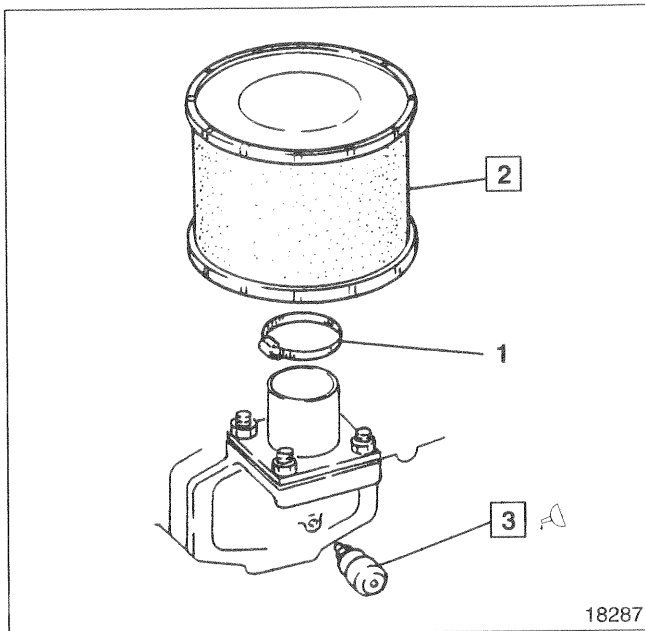

● Disassembly sequence

- 1 Clamp
- 2 Air cleaner
- 3 Dust indicator

● Reassembly sequence

Reverse the order of removal.

### Service standards

Location	Maintenance item	Standard value	Limit	Remedy
3	Negative pressure for operation of dust indicator	6.23 ± 0.57 kPa {635 ± 58 mmH <sub>2</sub> O}	—	Replace

### Sealant

Location	Points of application	Specified sealant	Quantity
3	Apply to threads of dust indicator	ThreeBond 1401B	As required

### ◆ Service procedure

#### 2 Cleaning air cleaner

[Cleaning]

Blow compressed air 685 kPa {7 kg/cm<sup>2</sup>} or less from inside the air cleaner 2, working along the creases of filter paper up and down to clean the air cleaner.

**CAUTION** ⚠

- Do not strike the element and do not blow the air from the suction portion.
- Make sure that the loosened dust is not blown into the element.

#### 3 Inspection of dust indicator

- Mount a hand vacuum pump A on the dust indicator and apply the standard operating negative pressure to check whether the red signal appears.

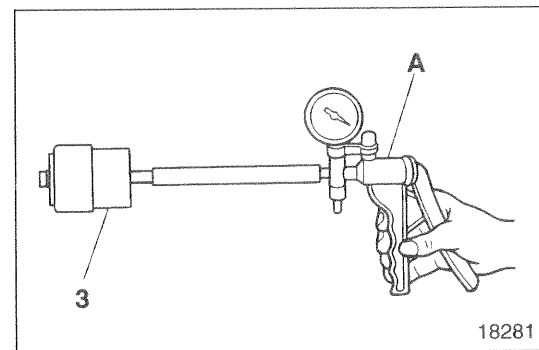
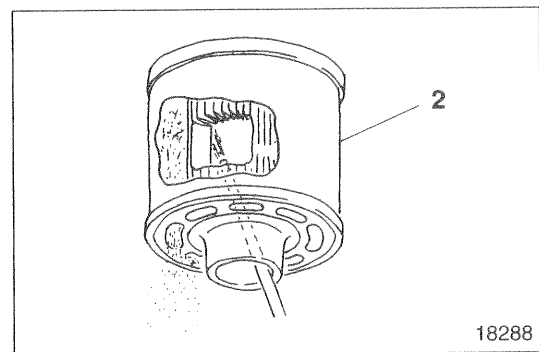

# TURBOCHARGER <T04B, T04E (6D16-TE)>

• If the red signal does not appear, replace the dust indicator 3.

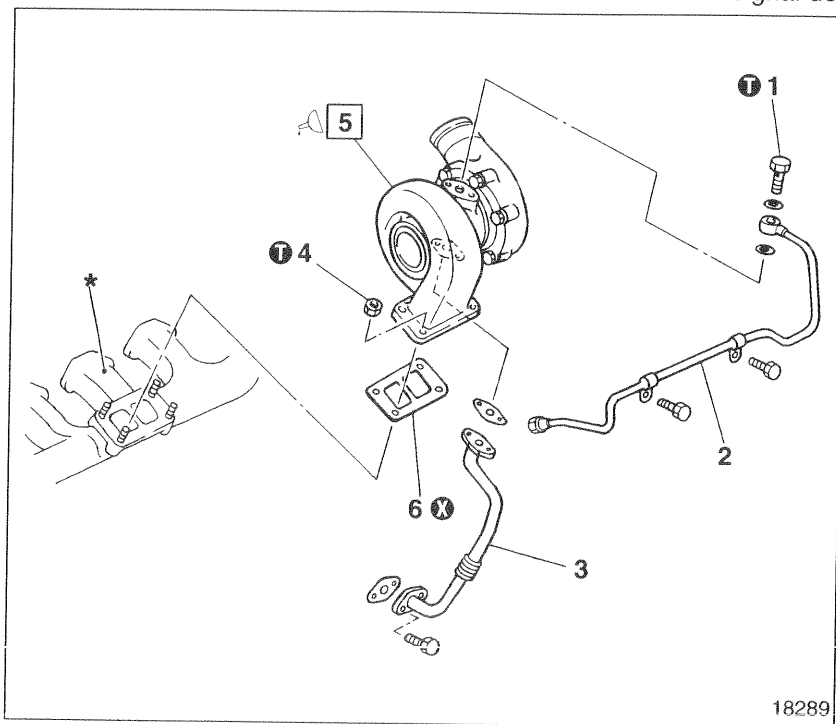

## ● Removal sequence

- 1 Eyebolt
  - 2 Oil inlet pipe
  - 3 Oil return pipe
  - 4 Nut
  - 5 Turbocharger assembly
- P.15-22  
 6 Gasket

\*: Exhaust manifold

P.15-63, 64

ⓧ: Non-reusable part

## ● Installation sequence

Reverse the order of removal.

## ⓘ Tightening torque

Unit: N · m {kgf · m}

Location	Parts to be tightened	Tightening torque	Remarks
1	Eyebolt (for mounting oil inlet pipe)	21 {2.1}	—
4	Nut (for mounting turbocharger assembly)	41 {4.2}	—

## Lubricant

Location	Points of application	Specified lubricant	Quantity
5	Supply when installing turbocharger assembly	Engine oil	As required

## ◆ Service procedure

### 5 Installation of turbocharger assembly

When the turbocharger assembly 5 is installed, supply engine oil from the oil hole A to make sure that all the parts operate smoothly.

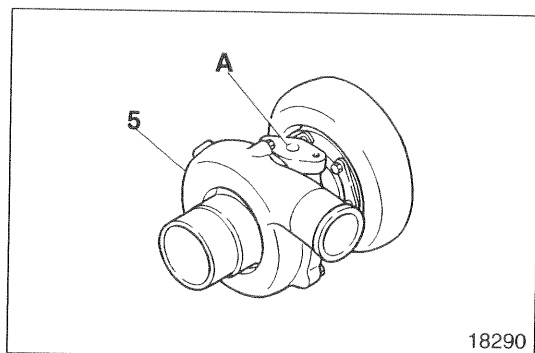

---

**M E M O**

---

# TURBOCHARGER <T04B, T04E (6D16-TE)>

## Turbocharger Assembly

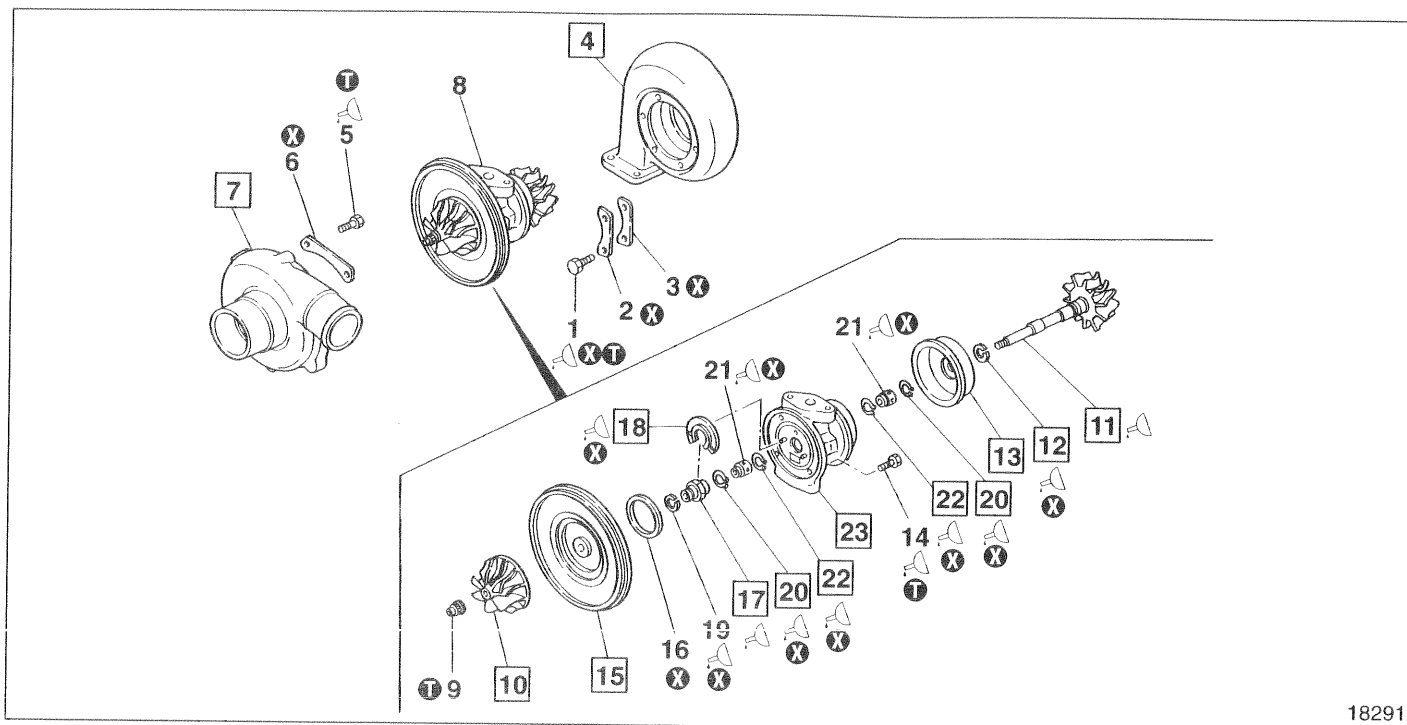

18291

### ● Operations before disassembly

📖 P.15-24

### ● Disassembly sequence

- |  |                     |                   |
|--|---------------------|-------------------|
| 1 Bolt                                 | 9 Lock nut          | 18 Thrust bearing |
| 2 Lock plate <T04B>                    | 10 Compressor wheel | 19 Piston ring    |
| 3 Clamp                                | 11 Turbine wheel    | 20 Retaining ring |
| 4 Turbine housing                      | 12 Piston ring      | 21 Bearing        |
| 5 Bolt                                 | 13 Wheel shroud     | 22 Retaining ring |
| 6 Clamp                                | 14 Bolt             | 23 Center housing |
| 7 Compressor housing                   | 15 Back plate       |                   |
| 8 Center housing and rotating assembly | 16 Seal ring        |                   |
|  | 17 Thrust collar    |                   |
- ⊗ : Non-reusable part

### CAUTION

Carefully remove piston rings 12 and 19, as they are readily broken.

### ● Cleaning after disassembly

📖 P.15-24

### ● Reassembly sequence

23 → 22 → 21 → 20 → 17 → 18 → 19 → 16 → 15 → 14 → 13  
 12 → 11 } → 10 → 9 → 8 → 7 → 6 → 5 → 4 → 3 → 2 → 1

### CAUTION

Do not widen the piston rings 12 and 19 more than necessary, as they are readily broken.

### ● Inspection after reassembly

📖 P.15-25

## Service standards

Unit: mm

Location	Maintenance item		Standard value (Basic diameter in [ ])	Limit	Remedy	
11	Turbine wheel	Bearing journal outside diameter	[10.156]	10.152 or more	Replace	
		Shaft bend	—	0.01 or less		
		Hub diameter	[17.31]	17.25 or more		
		Piston ring mounting portion	Groove width	1.69		1.74 or less
			Groove diameter	[14.46]		14.40 or more
		Play in radial direction	0.076 to 0.150	—		
		Play in thrust direction	0.025 to 0.076	—		
15	Back plate	Seal land height	T04B	11.652	11.658 or less	Replace
			T04E	11.672	11.684 or less	
		Seal bore inside diameter	[12.687]	12.712 or less		
17	Thrust collar	Piston ring mounting portion	Groove width	1.640	1.659 or less	Replace
			Groove diameter	[10.35]	10.29 or more	
		Thrust bearing mounting portion	Groove width	4.43	4.44 or less	
			Groove diameter	[9.53]	9.40 or more	
		Inside diameter	[6.358]	6.363 or less		
23	Center housing	Bearing inserting portion inside diameter	[15.800]	15.806 or less	Replace	
		Seal bore inside diameter	[18.03]	18.06 or less		

## ① Tightening torque

Unit: N·m {kgf·m}

Location	Parts to be tightened		Tightening torque	Remarks
1	Bolt (for mounting turbine housing)	T04B	18 to 21 {1.85 to 2.19}	—
		T04E	20 to 22 {2.07 to 2.29}	—
5	Bolt (for mounting compressor housing)		16 to 19 {1.67 to 1.89}	—
9	Lock nut (for mounting compressor wheel)		2.1 to 2.3 {0.21 to 0.23}	After tightening, turn down 90°C to 110°C further from that position.
14	Bolt (for mounting back plate)		12 to 14 {1.26 to 1.45}	—

## 🔧 Lubricant

Location	Points of application	Specified lubricant	Quantity
1	Apply to threads and bearing surface of bolt	MOLYKOTE	As required
5, 14	Apply to threaded portion of bolt	LOCTITE	As required
11, 12, 17 to 22	Apply to all of the parts	Engine oil	As required

# TURBOCHARGER <T04B, T04E (6D16-TE)>

## ☑ Special tools

Location	Tool name and shape	Part No.	Application
10	T-handle	801059-0	Removal and installation of compressor wheel
	Holding fixture	801053-0	
11	Measuring element	801098-0	Inspection of play of turbine wheel in radial direction
12	Piston ring inserter	801050-0	Installation of piston ring
20, 22	Retaining ring remover	801058-0	Removal and installation of retaining ring

Part numbers listed above are Honeywell part numbers.

## ◆ Service procedure

### ● Operations before disassembly

Make alignment marks **A** on the turbine housing **4**, compressor housing **7** and center housing rotating assembly **8**.

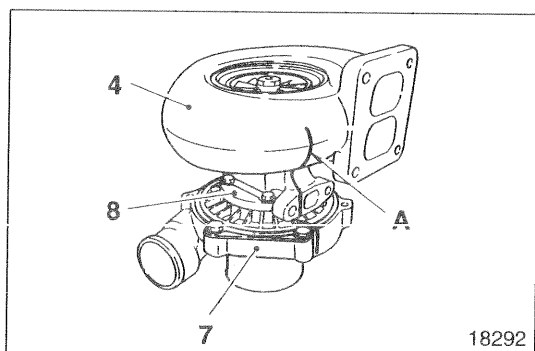

18292

### ● Cleaning after disassembly

- Before cleaning, visually check the individual parts for burns, rubbed stains, etc. which might disappear after cleaning. If there is anything wrong, replace.
- Immerse the disassembled parts in a non-combustible solvent (DAIDO CHEMICAL INDUSTRY CO., LTD. DAI CLEANER T-30).

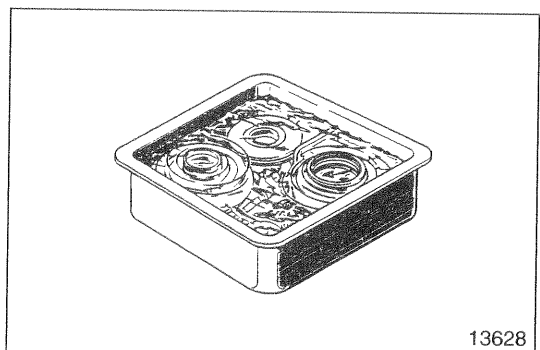

13628

- Take out the parts from the solvent and blow compressed air **A** against them.

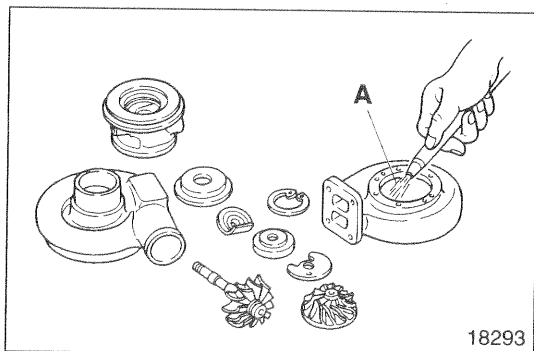

18293

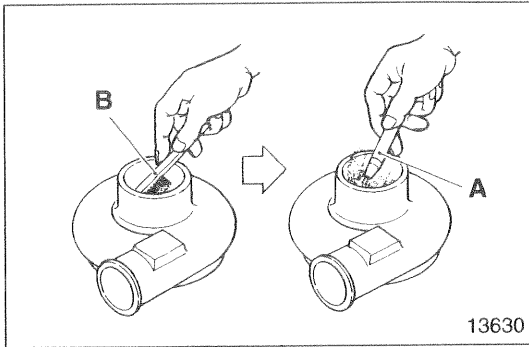

- Scrape off deposits.
- B**: Plastic scraper or stiff brush
- Re-immers in the solvent.
- Blow compressed air **A**.

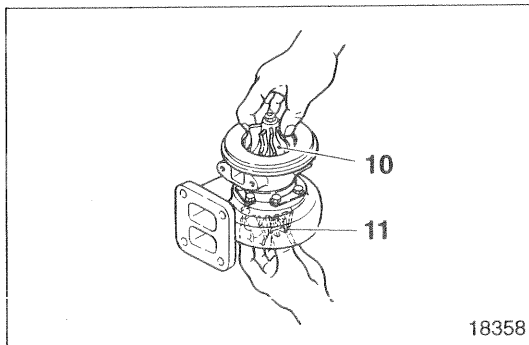

### ● Inspection after reassembly

- (1) Manually rotate the compressor wheel **10** and turbine **11** to check whether they rotate smoothly.

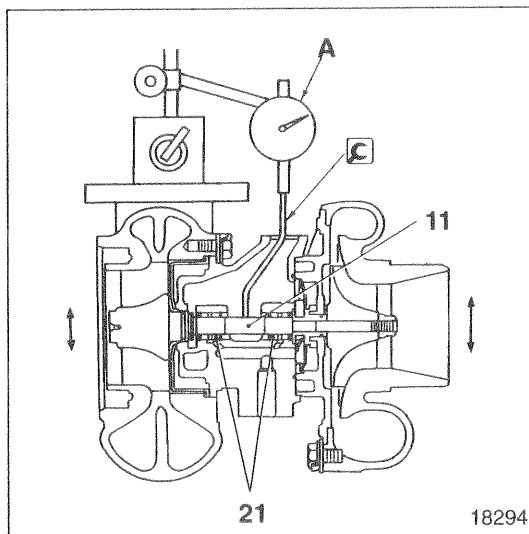

### (2) Play of turbine wheel in radial direction

- Mount the  Probe to the dial indicator **A** and insert it from the oil outlet and press it against the shaft of the turbine wheel **11** at right angles.
- Move the shaft of the turbine wheel **11** up and down by both hands to measure the play in the radial direction.
- If the reading is in excess of the limit, replace the bearing **21**.

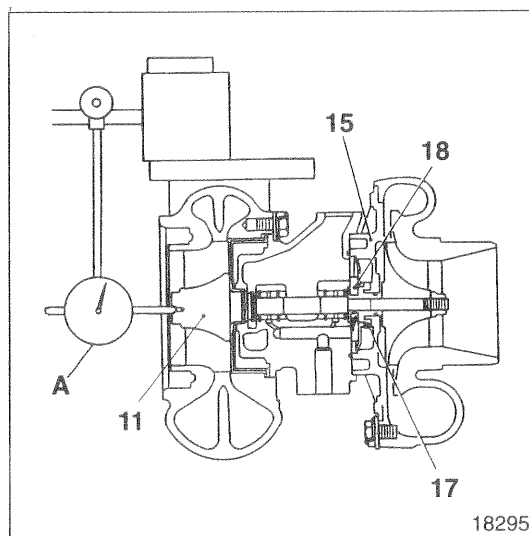

### (3) Play of turbine wheel in thrust direction

- Set the dial indicator **A** on the end of the turbine wheel **11** and move the shaft of the turbine wheel in the axial direction to measure the play.
- If the reading exceeds the limit, worn or defective back plate **15**, thrust collar **17** and thrust bearing **18** are suspected. Replace.

# TURBOCHARGER <T04B, T04E (6D16-TE)>

## 4 Turbine housing

[Removal]

A: Rubber hammer

### CAUTION

- While using care to prevent damage to the turbine housing 4, lightly strike its entire circumference with a rubber hammer or similar tool.
- Since the blades of the turbine wheel are readily bent, use care to make sure that they do not hit the turbine housing 4.

[Installation]

- Apply the MOLYKOTE to the threads and bearing surface of the bolt 1, partially tighten the bolt, line up the alignment marks made before disassembly, and then tighten the bolt to the specified torque.
- Bend the lock plate 2 at two places against the bolts 1. <T04B>

### CAUTION

Use care to prevent damage to the blades of the turbine wheel 11.

## 7 Compressor housing

[Removal]

A: Rubber hammer

### CAUTION



- While using care to prevent damage to the compressor housing 7, lightly strike its entire circumference with a rubber hammer A or similar tool.
- Since the blades of the compressor wheel 10 are readily bent, use care to make sure that they do not hit the compressor housing 7.

[Installation]

Place the center housing & rotating assembly 8 on the compressor housing 7, line up the alignment marks made before disassembly, and tighten the bolt 1 to the specified torque.

## 10 Compressor wheel

[Removal]

- Hold the  a Holding Fixture in a vice, and slowly insert the center housing & rotating assembly 8.
- Using the  b T-handle, remove the lock nut 9 and slowly withdraw the compressor wheel 10 upward.

### CAUTION

Use care to prevent bending the shaft of the turbine wheel 11.

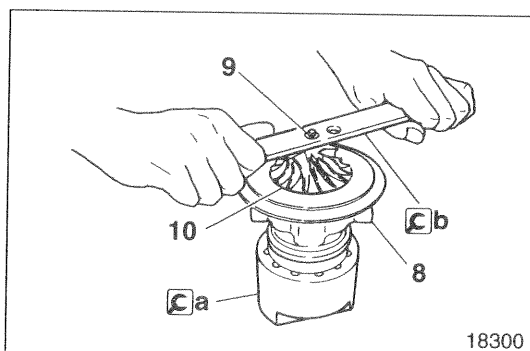
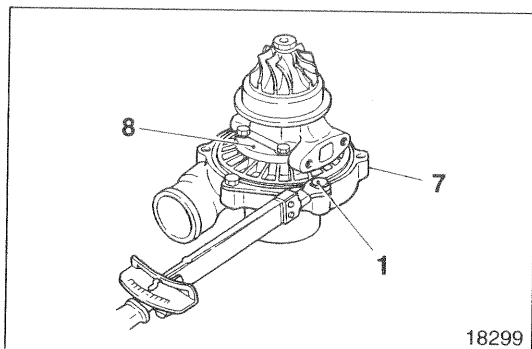
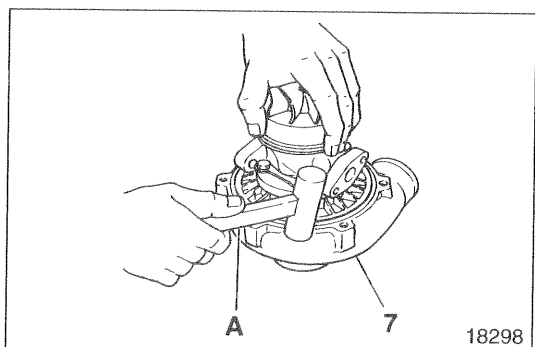
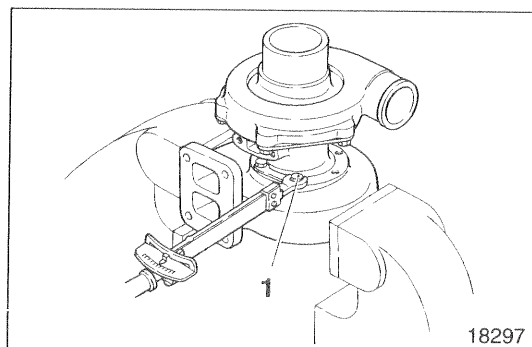
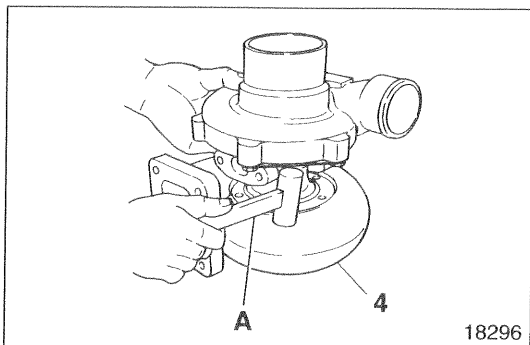

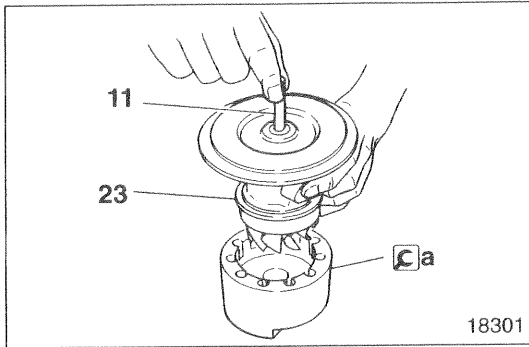

[Installation]

- Hold the shaft of the turbine wheel 11 and center housing 23 by hand, and slowly insert them into the (a) Holding Fixture.

**CAUTION** ⚠

- When they are inserted, use care to prevent damage to the blades of the turbine wheel 11.
- Do not release the shaft before insertion, as the turbine wheel 11 falls down.

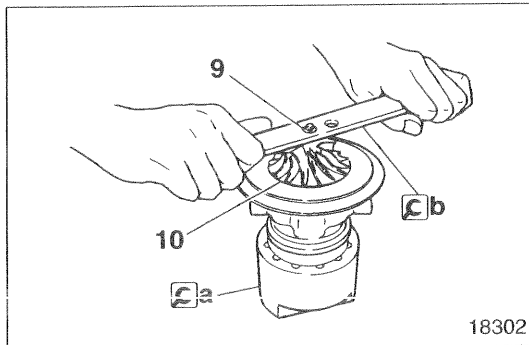

- Hold the (a) Holding Fixture in a vice and slowly insert the compressor wheel 10.
- Using the (b) T-handle, tighten the lock nut 9 to the specified torque, and then turn it down 90°C to 110°C further from that position.

**CAUTION** ⚠

Use care to prevent bending the shaft of the turbine wheel 11.

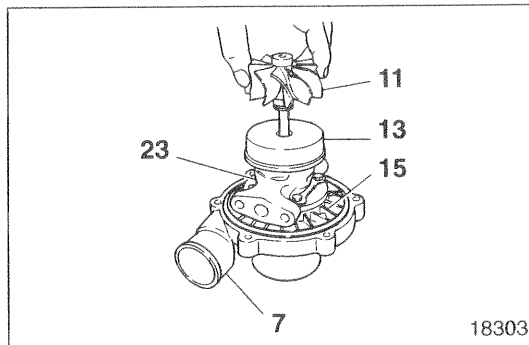

**11 13** Turbine wheel, wheel shroud

[Removal]

Place the back plate 15 side of the center housing 23 on the compressor housing 7 removed beforehand, and remove the turbine wheel 11 and wheel shroud 13.

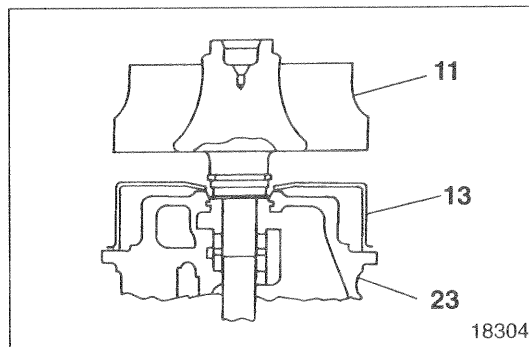

[Installation]

After installation, lightly rotate the turbine wheel 11 by hand to check whether it continues to rotate. If it does not rotate lightly, re-perform the disassembly and reassembly procedures.

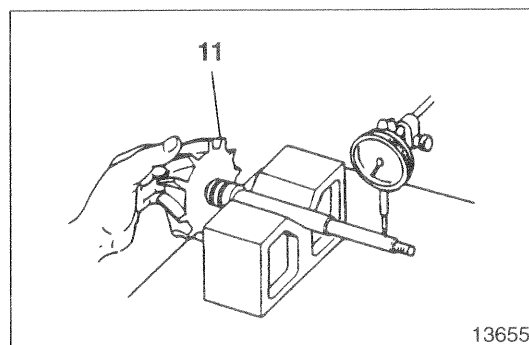

[Inspection]

**(1) Bend of shaft**

- Using the dial indicator, measure at the illustrated position.
- If the reading exceeds limit, replace the turbine wheel 11.

# TURBOCHARGER <T04B, T04E (6D16-TE)>

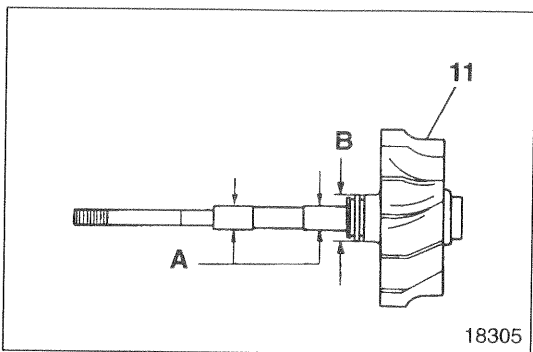

## (2) Outside diameters of journal and hub

If any readings exceeds of the limit, replace the turbine wheel 11.

A : Journal

B : Hub

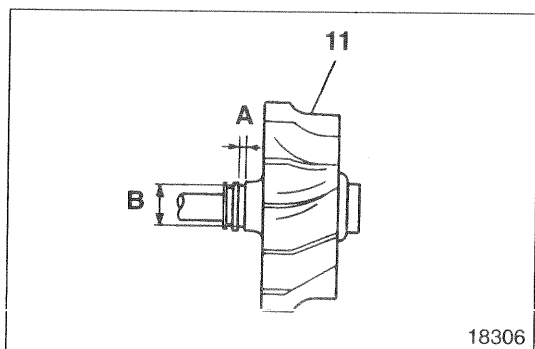

## (3) Width and outside diameter of piston ring groove

If any reading exceeds of the limit, replace the turbine wheel 11.

A : Width

B : Outside diameter

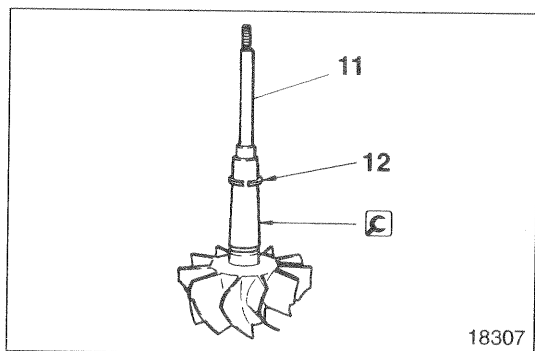

## 12 Installation of piston ring

Insert the  Piston Ring Inserter into the turbine wheel 11 and install the piston ring 12.

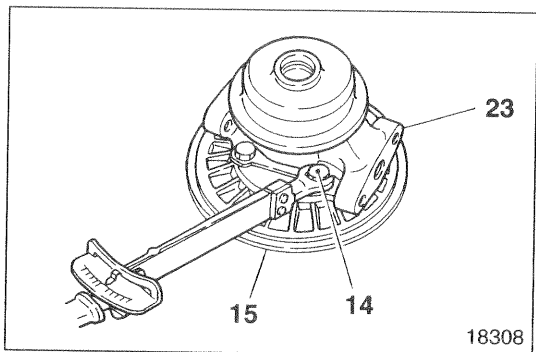

## 15 Back plate

[Installation]

Slowly install the back plate 15 on the center housing 23, while lining up the alignment marks made before disassembly, and tighten the bolt 14 to the specified torque.

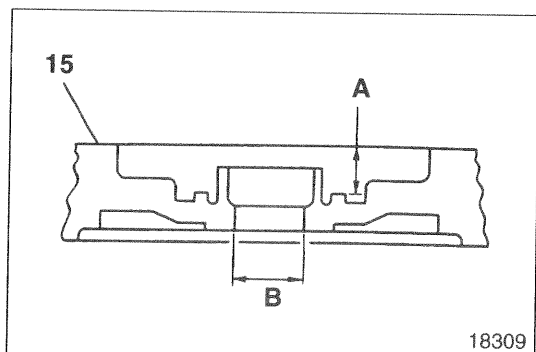

[Inspection]

- Measure the seal land height **A** and seal bore inside diameter **B** of the back plate 15.
- If any reading exceeds the limit, replace the back plate 15.

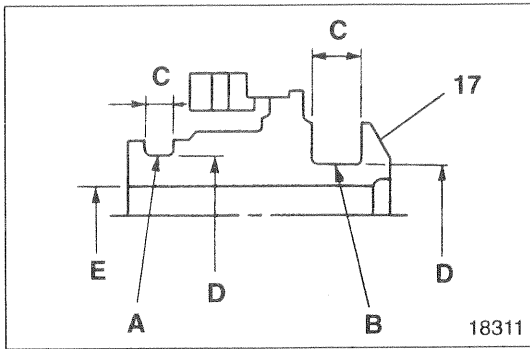

- 17** Piston ring groove and groove diameter of thrust collar and thrust bearing groove width, groove diameter and bore inside diameter

If any reading exceeds the limit, replace the thrust collar.

- A: Piston ring groove  
 B: Thrust bearing groove  
 C: Groove width  
 D: Groove diameter  
 E: Bore inside diameter

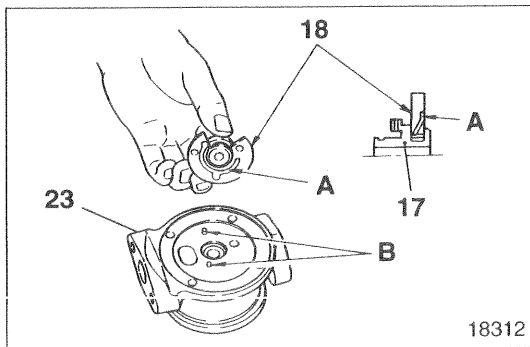

- 18** Installation of thrust bearing

Install the thrust bearing 18 on the thrust collar 17 with the oil groove A toward the center housing 23, and insert it onto the positioning pins B of the center housing.

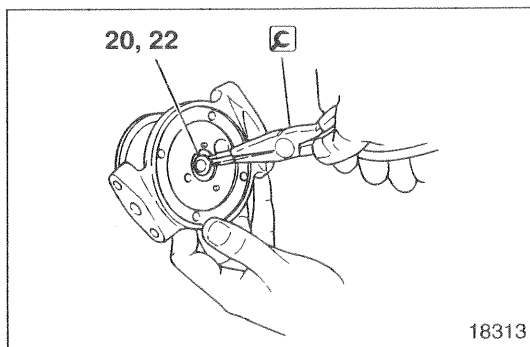

- 20** **22** Retaining ring

[Removal]

- C**: Retaining Ring Remover

**CAUTION** ⚠

When the retaining rings 20 and 22 are removed, hold your hand over the rings to make sure that they do not bounce out.

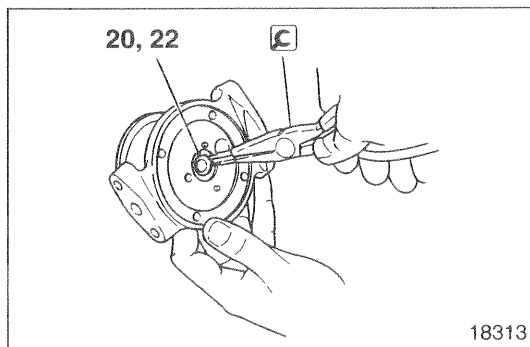

[Installation]

Install the retaining rings 20 and 22 securely in the groove of the center housing.

**CAUTION** ⚠

When the retaining rings 20 and 22 are installed, hold your hand over the rings to make sure that they do not bounce out.

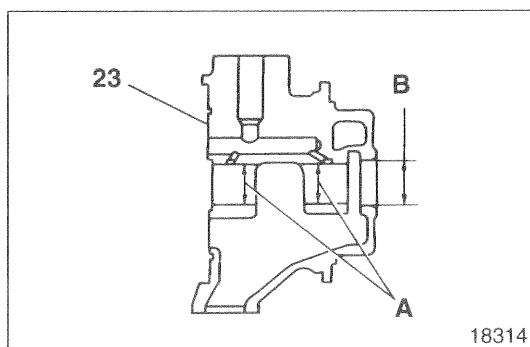

- 23** Check the bearing inserting portion inside diameter and seal bore diameter of the center housing.

If any reading exceeds the limit, replace the center housing 23.

- A: Bearing inserting portion inside diameter  
 B: Seal bore diameter

# TURBOCHARGER <T04E (6D16-TL), TBP4>

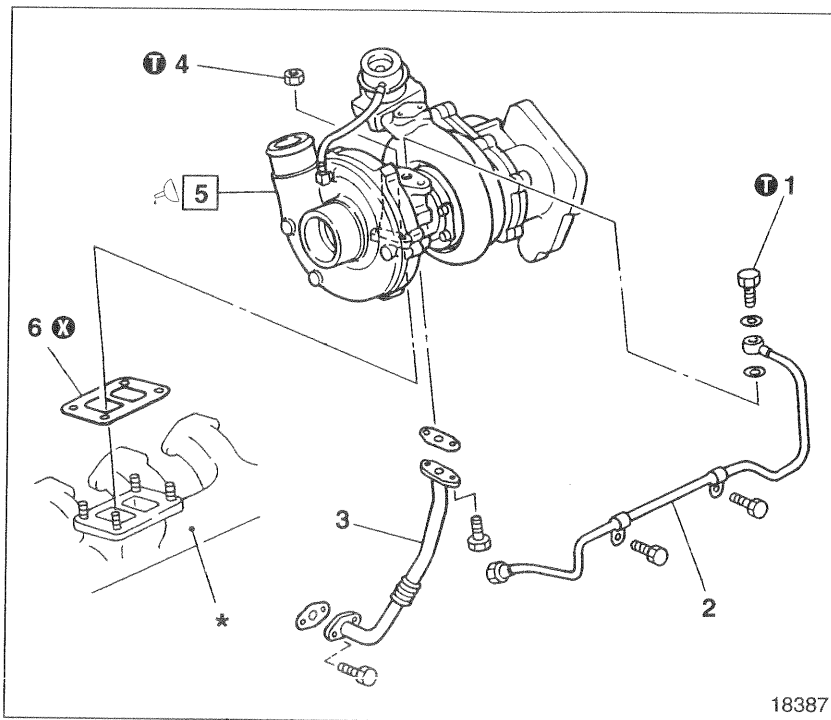

## ● Removal sequence

- 1 Eyebolt
- 2 Oil inlet pipe
- 3 Oil return pipe
- 4 Nut
- 5 Turbocharger assembly P.15-32
- 6 Gasket

\*: Exhaust manifold P.15-63, 64

⊗: Non-reusable part

## ● Installation sequence

Reverse the order of removal.

## ① Tightening torque

Unit: N · m {kgf · m}

Location	Parts to be tightened	Tightening torque	Remarks
1	Eyebolt (for mounting oil inlet pipe)	21 {2.1}	—
4	Nut (for mounting turbocharger assembly)	41 {4.2}	—

## Lubricant

Location	Points of application	Specified lubricant	Quantity
5	Supply when installing turbocharger assembly	Engine oil	As required

## ◆ Service procedure

### 5 Installation of turbocharger assembly

When the turbocharger assembly 5 is installed, supply engine oil from the oil hole A to make sure that all the parts operate smoothly.

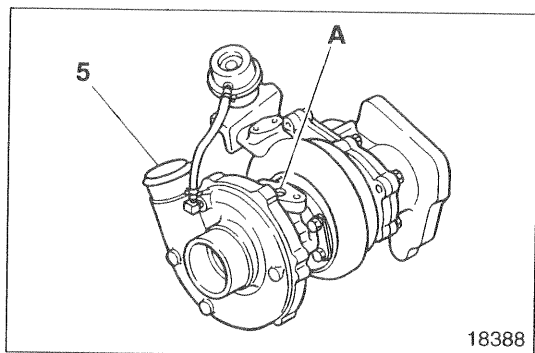

---

**MEMO**

---

# TURBOCHARGER <T04E (6D16-TL), TBP4>

## Turbocharger Assembly

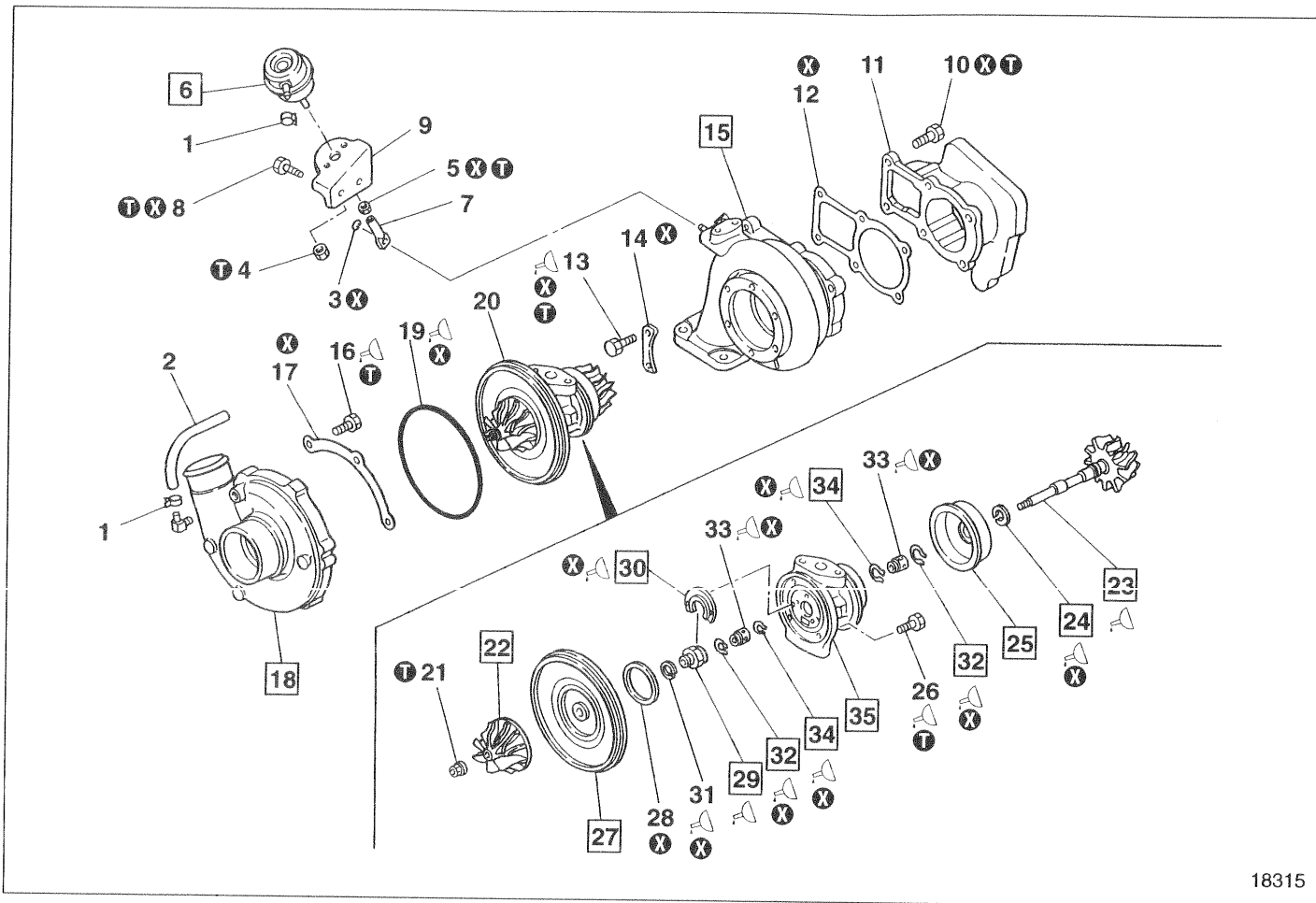

18315

### ● Operations before disassembly

📖 P.15-34

### ● Disassembly sequence

- |                     |                                       |                   |
|---------------------|---------------------------------------|-------------------|
| 1 Hose clamp        | 14 Clamp                              | 26 Bolt           |
| 2 Hose              | 15 Turbine housing                    | 27 Back plate     |
| 3 Retaining ring    | 16 Bolt                               | 28 Seal ring      |
| 4 Nut               | 17 Clamp                              | 29 Thrust collar  |
| 5 Nut               | 18 Compressor housing                 | 30 Thrust bearing |
| 6 Actuator assembly | 19 O-ring                             | 31 Piston ring    |
| 7 Rod end           | 20 Center housing & rotating assembly | 32 Retaining ring |
| 8 Bolt              | 21 Lock nut                           | 33 Bearing        |
| 9 Bracket           | 22 Compressor wheel                   | 34 Retaining ring |
| 10 Bolt             | 23 Turbine wheel                      | 35 Center housing |
| 11 Exhaust coupler  | 24 Piston ring                        |                   |
| 12 Gasket           | 25 Wheel shroud                       |                   |
| 13 Bolt             |                                       |                   |
- ⊗ : Non-reusable part

### CAUTION ⚠

Carefully remove the piston rings 24 and 31, as they are readily broken.

● **Cleaning after disassembly**

📖 P.15-35

● **Reassembly sequence**

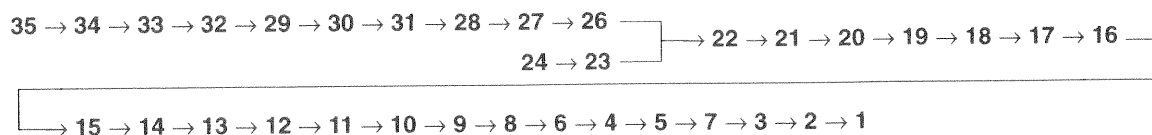

**CAUTION** ⚠

Do not widen the piston rings 24 and 31 more than necessary, as they are readily broken.

● **Inspection after reassembly**

📖 P.15-35

**Service standards**

Unit: mm

Location	Maintenance item		Standard value (Basic diameter in [ ])	Limit	Remedy	
6	Actuator assembly set pressure		83 to 90 kPa {625 to 675 mmHg}	—	Adjust	
23	Turbine wheel	Bearing journal outside diameter	[10.156]	10.152 or more	Replace	
		Shaft bend	—	0.01 or less		
		Hub diameter	[17.31]	17.25 or more		
		Piston ring mounting portion	Groove width	1.69		1.74 or less
			Groove diameter	[14.46]		14.40 or more
		Play in radial direction	0.076 to 0.150	—		Check
Play in thrust direction	0.025 to 0.076	—				
27	Back plate	Seal land height	11.672	11.658 or less	Replace	
		Seal bore inside diameter	[12.687]	12.712 or less		
29	Thrust collar	Piston ring mounting portion	Groove width	1.640	1.659 or less	Replace
			Groove diameter	[10.35]	10.29 or more	
		Thrust bearing mounting portion	Groove width	4.43	4.44 or less	
			Groove diameter	[9.53]	9.40 or more	
		Inside diameter	[6.358]	6.363 or less		
35	Center housing	Bearing inserting portion inside diameter	[15.800]	15.806 or less	Replace	
		Seal bore inside diameter	[18.03]	18.06 or less		

# TURBOCHARGER <T04E (6D16-TL), TBP4>

## ① Tightening torque

Unit: N·m {kgf·m}

Location	Parts to be tightened	Tightening torque	Remarks
4	Nut (for mounting actuator assembly)	5.6 to 7.8 {0.57 to 0.80}	—
5	Nut (for mounting rod end)	5.6 to 6.8 {0.57 to 0.70}	—
8	Bolt (for mounting bracket)	20 to 22 {2.07 to 2.29}	—
10	Bolt (for mounting exhaust coupler)	20 to 22 {2.07 to 2.29}	—
13	Bolt (for mounting clamp)	20 to 22 {2.07 to 2.29}	—
16	Bolt (for mounting clamp)	16 to 19 {1.67 to 1.89}	—
21	Lock nut (for mounting compressor wheel)	2.1 to 2.3 {0.21 to 0.23}	After tightening, turn down 90°C to 110°C further from that position.
26	Bolt (for mounting back plate)	12 to 14 {1.26 to 1.45}	—

## 🔧 Lubricant

Location	Points of application	Specified lubricant	Quantity
13	Apply to threads and bearing surface of bolt	MOLYKOTE	As required
16, 26	Apply to threaded portion of bolt	LOCTITE	As required
19, 23, 24, 29 to 34	Apply to all of the parts.	Engine oil	As required

## 🔧 Special tools

Location	Tool name and shape	Part No.	Application
22	T-handle	801059-0	Removal and installation of compressor wheel
	Holding fixture	801053-0	
23	Measuring element	801098-0	Inspection of play of turbine wheel in radial direction
24	Piston ring inserter	801050-0	Installation of piston ring
32, 34	Retaining ring remover	801058-0	Removal and installation of retaining ring

Part numbers listed above are Honeywell part numbers.

## ◆ Service procedure

### ● Operations before disassembly

Make alignment mark **A** on the turbine housing **15**, compressor housing **18** and center housing & rotating assembly **20**.

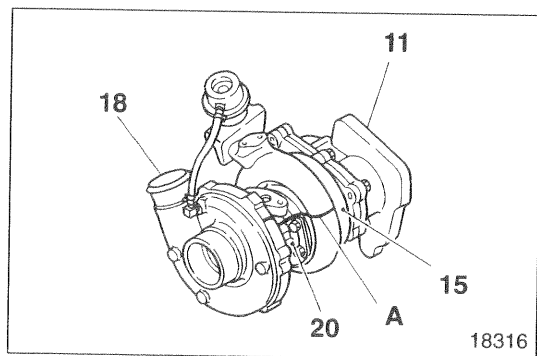

### ● Cleaning after disassembly

- Before cleaning, visually check the individual parts for burns, rubbed stains, etc. which might disappear after cleaning. If there is anything wrong, replace.

### CAUTION

Do not immerse the actuator assembly 6 in the solvent. Clean it with a cloth dipped in kerosene.

- Immerse the disassembled parts in a non-combustible solvent (DAIDO CHEMICAL INDUSTRY CO., LTD. DAI CLEANER T-30).

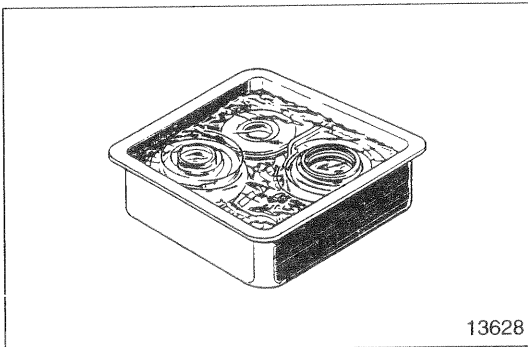

- Take out the parts from the solvent and blow compressed air **A** against them.

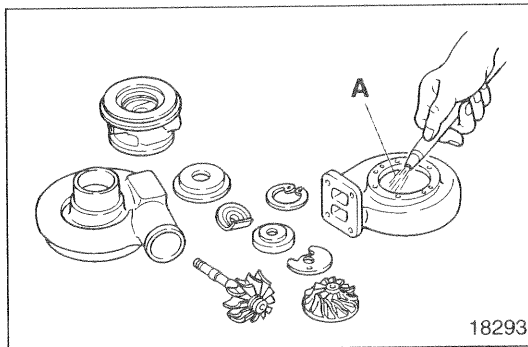

- Scrape off deposits.

**B:** Plastic scraper or stiff brush

- Re-immers in the solvent.
- Blow compressed air **A**.

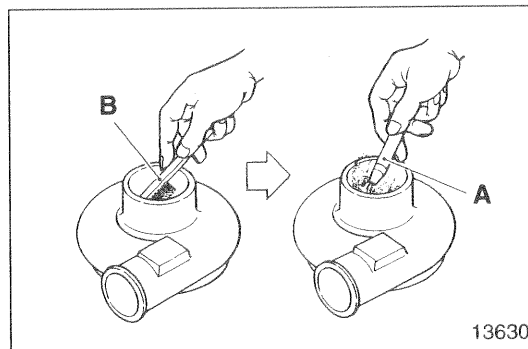

### ● Inspection after reassembly

- (1) Manually rotate the compressor wheel **22** and turbine wheel **23** to check whether they rotate smoothly.

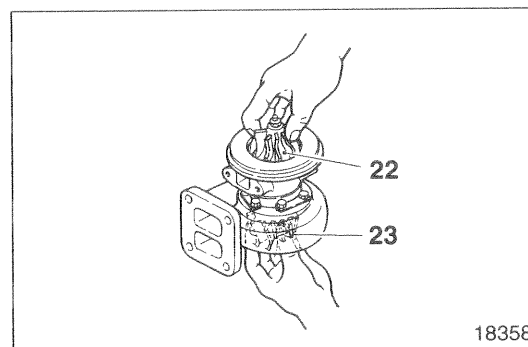

# TURBOCHARGER <T04E (6D16-TL), TBP4>

## (2) Play of turbine wheel in radial direction

- Mount the  Measuring Element to the dial gauge **A** and insert it from the oil outlet and press it against the shaft of the turbine wheel **23** at right angles.
- Move the shaft of the turbine wheel **23** up and down by both hands to measure the play in the radial direction.
- If the reading exceeds the limit, replace the bearing **33**.

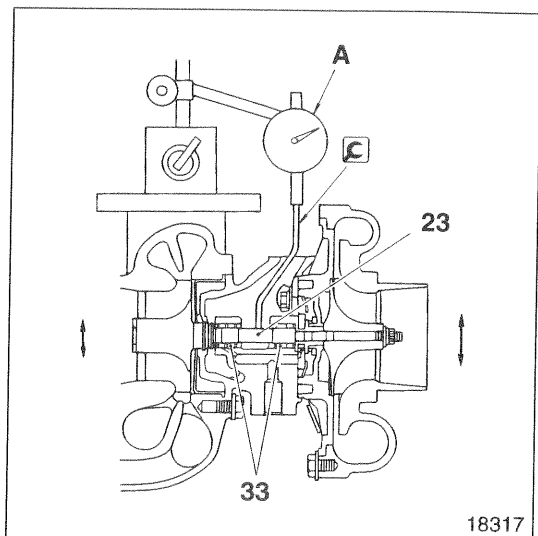

18317

## (3) Play of turbine wheel in thrust direction

- Set the dial gauge **A** on the end of the turbine wheel **23** and move the shaft of the turbine wheel in the axial direction to measure the play.
- If the reading exceeds the limit, worn or defective back plate **27**, thrust collar **29** and thrust bearing **30** are suspected. Replace.

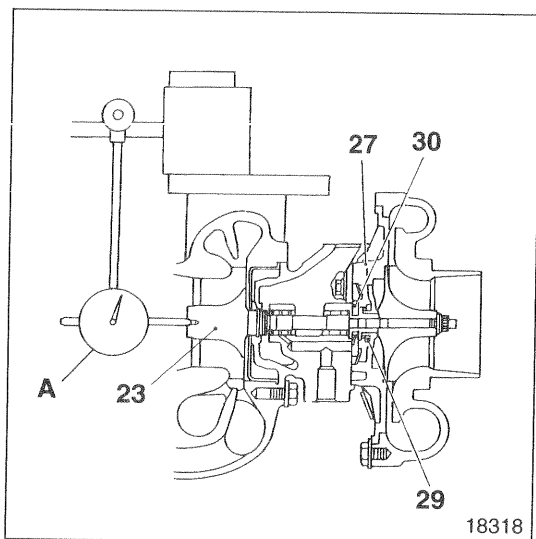

18318

## (4) Measurement of operating pressure of actuator assembly

- Set the dial indicator **A** on the end of the rod end **7**.  
(In this case, set the scale of the dial indicator to 0.)
- Extend the rod end 0.38 mm by use of the external air **B**.  
(The scale of the dial indicator **A** is 0.38 mm.)
- With the scale of the dial indicator **A** at 0.38 mm, read the value of the pressure gauge **C**, and check to ensure that the reading is between 83 and 90 kPa {625 to 675 mmHg}.

## (5) Adjustment of operating pressure of actuator assembly

- If the reading of the pressure gauge **C** is not between 83 and 90 kPa {625 to 675 mmHg}, remove the retaining ring **3**, loosen the nut **5**, and adjust the length of the rod end **7**.

Rod end length adjusting direction

Rod end extending direction → Reduces the pressure.

Rod end retracting direction → Increases the pressure.

### CAUTION

When the rod end length is adjusted, if the piston assembly **D** is rotated, damage to the diaphragm in the actuator assembly **6** will result. Secure the piston assembly through use of a vice, pliers, etc. to make sure that it is not rotated.

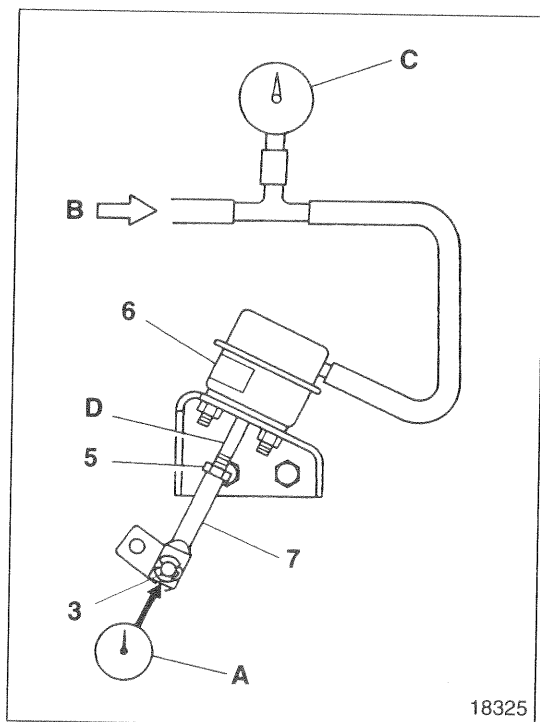

18325

**6 Air-tightness check on actuator assembly**

Slowly apply the air pressure **A** to the actuator assembly **6** to check that there are no air leaks when the air pressure is 87 kPa (650 mmHg). If there are air leaks, replace the actuator assembly.

**B**: Pressure gauge

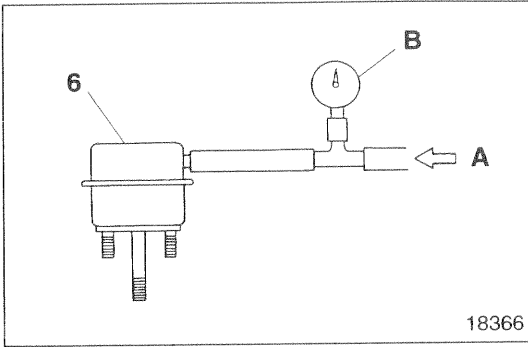
**15 Turbine housing**

[Removal]

**A**: Rubber hammer

**CAUTION** ⚠

- While using care to prevent damage to the turbine housing **15**, lightly strike its entire circumference with a rubber hammer or similar tool.
- Since the blades of the turbine wheel **23** are readily bent, use care to make sure that they do not hit the turbine housing **15**.

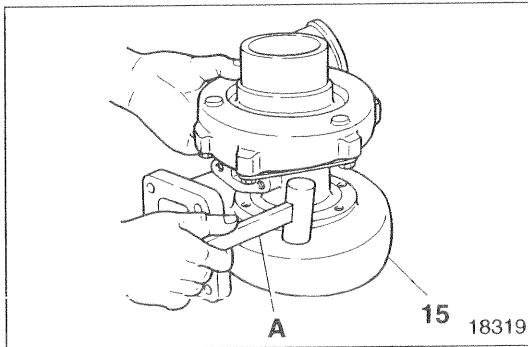

[Installation]

Apply MOLYKOTE to the threads and bearing surface of bolt **13**, partially tighten the bolt, line up the alignment marks made before disassembly, and then tighten the bolt to the specified torque.

**CAUTION** ⚠

Use care to prevent damage to the blades of the turbine wheel **23**.

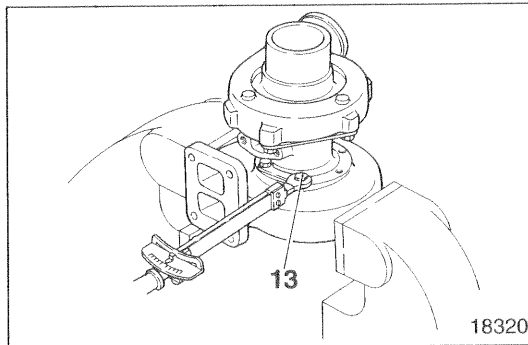
**18 Compressor housing**

[Removal]

**A**: Rubber hammer

**CAUTION** ⚠

- While using care to prevent damage to the compressor **18**, lightly strike its entire circumference with a rubber hammer **A** or similar tool.
- Since the blades of the compressor wheel **22** are readily bent, use care to make sure that they do not hit the compressor housing **18**.

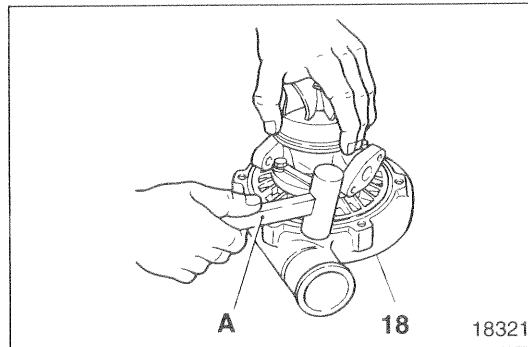

[Installation]

- Place the center housing & rotating assembly **20** on the compressor housing **18**, line up the alignment marks made before disassembly, and tighten the bolt **16** to the specified torque.

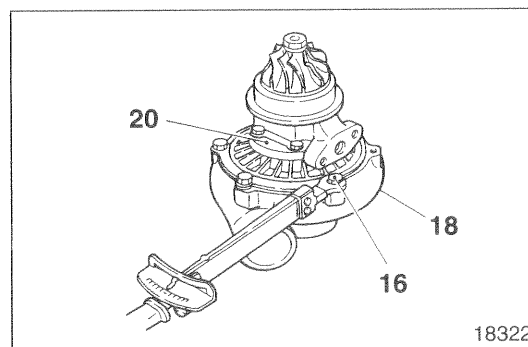

# TURBOCHARGER <T04E (6D16-TL), TBP4>

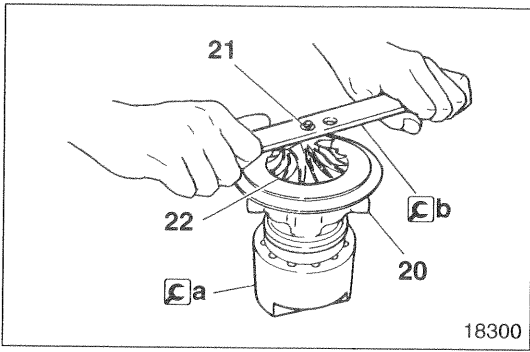

## 22 Compressor wheel

[Removal]

- Hold the 2a Holding Fixture in a vice, and slowly insert the center housing & rotating assembly 20.
- Using the 2b T-handle, remove the lock nut 21 and slowly withdraw the compressor wheel 22 upward.

**CAUTION** ⚠

Use care to prevent bending the shaft of the turbine wheel 23.

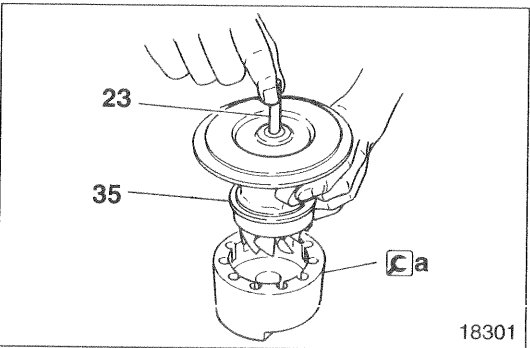

[Installation]

- Hold the shaft of the turbine wheel 23 and center housing 35 by hand, and slowly insert them into the 2a Holding Fixture.

**CAUTION** ⚠

- When they are inserted, use care to prevent damage to the blades of the turbine wheel 23.
- Do not release the shaft before insertion, as the turbine wheel 23 falls down.

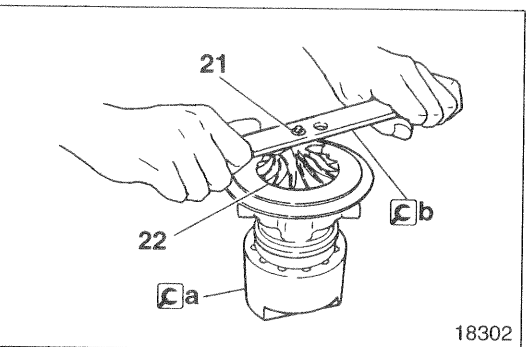

- Hold the 2a Holding Fixture in a vice and slowly insert the compressor wheel 22.
- Using the 2b T-handle, tighten the lock nut 21 to the specified torque, and then turn it down 90°C to 110°C further from that position.

**CAUTION** ⚠

Use care to prevent bending the shaft of the turbine wheel 23.

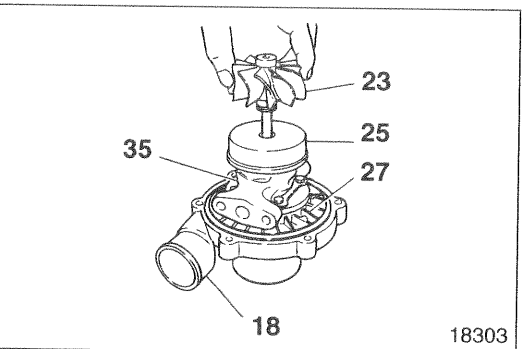

## 23 25 Turbine wheel, wheel shroud

[Removal]

Place the back plate 27 of the center housing 35 on the compressor housing 18 removed beforehand, and remove the turbine wheel 23 and wheel shroud 25.

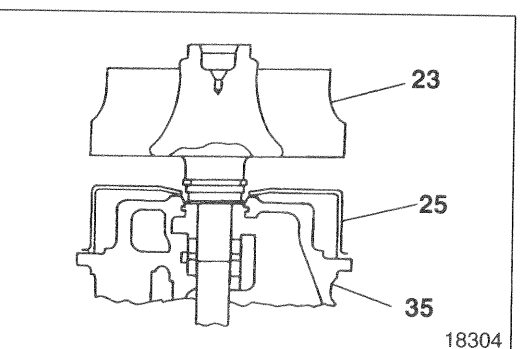

[Installation]

After installation, lightly rotate the turbine wheel 23 by hand to check whether it continues to rotate. If it does not rotate lightly, re-perform the disassembly and reassembly procedures.

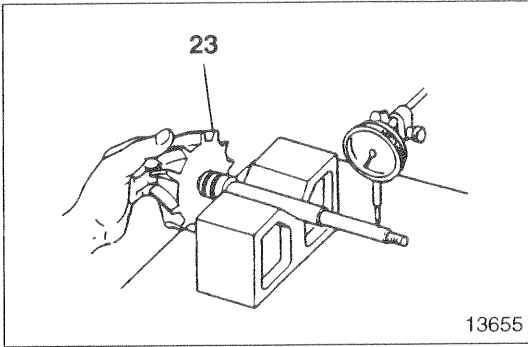

[Inspection]

**(1) Bend of shaft**

- Using the dial indicator, measure at the illustrated position.
- If the reading exceeds the limit, replace the turbine wheel 23.

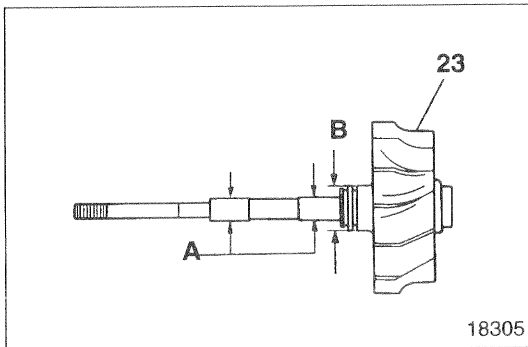

**(2) Outside diameters of journal and hub**

If any reading exceeds the limit, replace the turbine wheel 23.

A: Journal

B: Hub

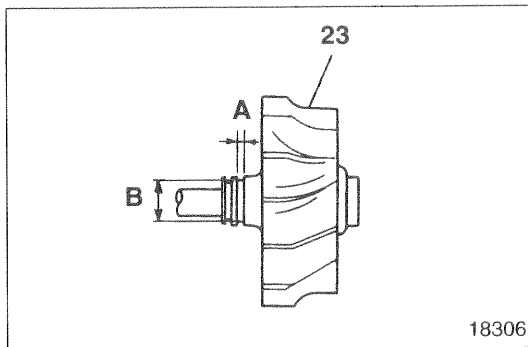

**(3) Width and outside diameter of piston ring groove**

If any reading exceeds the limit, replace the turbine wheel 23.

A: Width

B: Outside diameter

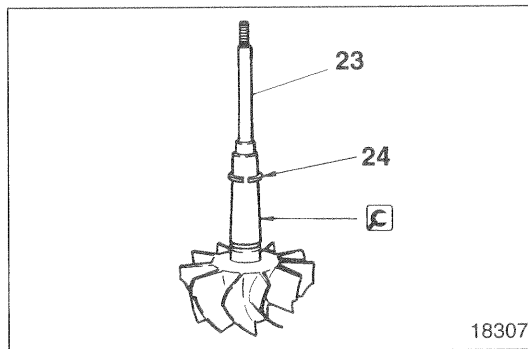

**24 Installation of piston ring**

Insert the  Piston Ring Inserter into the turbine wheel 23 and install the piston ring 24.

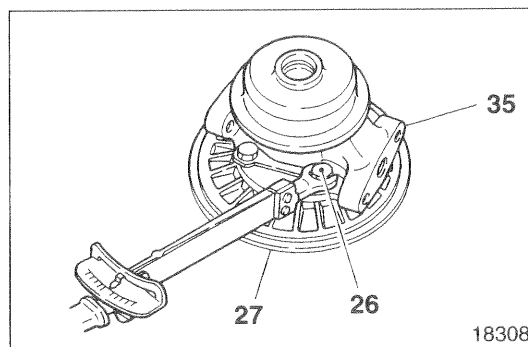

**27 Back plate**

[Installation]

Slowly install the back plate 27 on the center housing 35, while lining up the alignment marks made before disassembly, and tighten the bolt 26 to the specified torque.

# TURBOCHARGER <T04E (6D16-TL), TBP4>

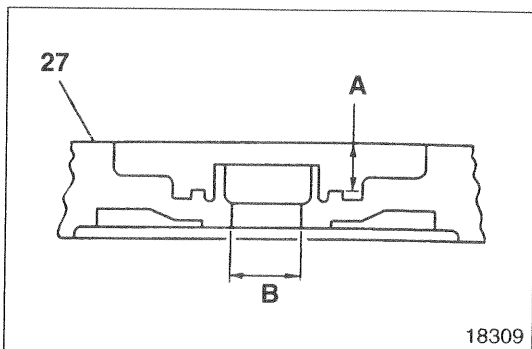

[Inspection]

- Measure the seal land height **A** and seal bore inside diameter **B** of the back plate **27**.
- If any reading exceeds the limit, replace the back plate **27**.

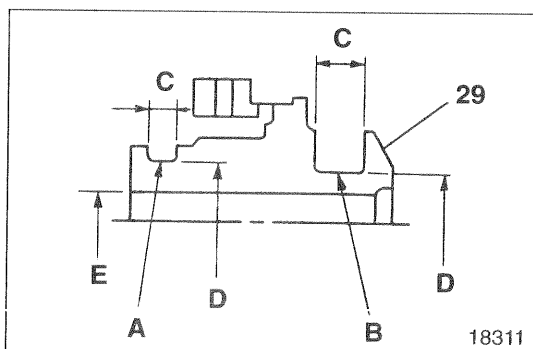

- 29** Piston ring groove and groove diameter of thrust collar and thrust bearing groove width, groove diameter and bore inside diameter

If any reading exceeds the limit, replace the thrust collar **29**.

- A**: Piston ring groove
- B**: Thrust bearing groove
- C**: Groove width
- D**: Groove diameter
- E**: Bore inside diameter

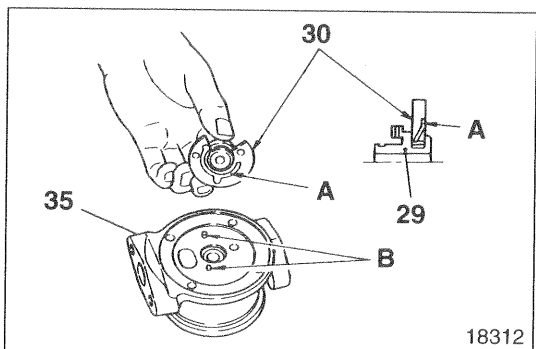

- 30** Installation of thrust bearing

Install the thrust bearing **30** on the thrust collar **29** with the oil groove **A** toward the center housing **35**, and insert it onto the positioning pins **B** of the center housing.

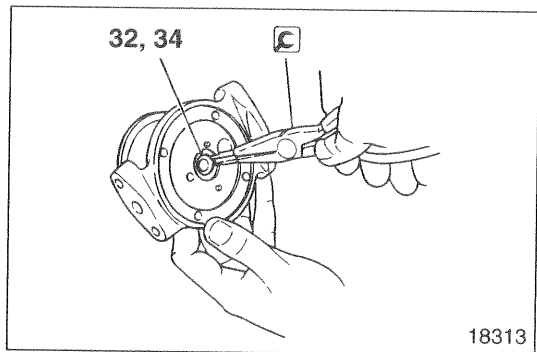

- 32** **34** Retaining ring

[Removal]

- C**: Retaining Ring Remover

**CAUTION** ⚠

When the retaining rings **32** and **34** are removed, hold your hand over the rings to make sure that they do not bounce out.

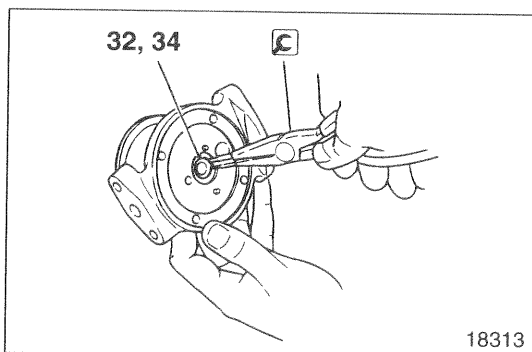

[Installation]

Install the retaining rings **32** and **34** securely in the groove of the center housing.

**CAUTION** ⚠

When the retaining rings **32** and **34** are installed, hold your hand over the rings to make sure that they do not bounce out.

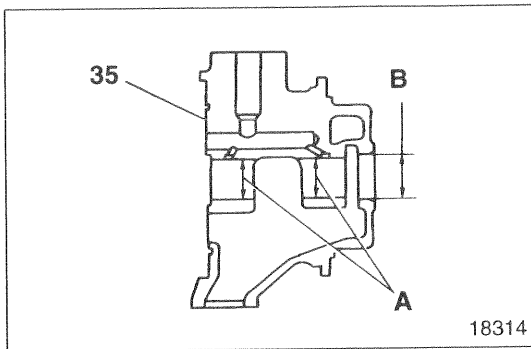

**35** Check the bearing inserting portion inside diameter and seal bore diameter of the center housing.

If any reading exceeds the limit, replace the center housing 35.

**A**: Bearing inserting portion inside diameter

**B**: Seal bore diameter

# TURBOCHARGER <TF07>

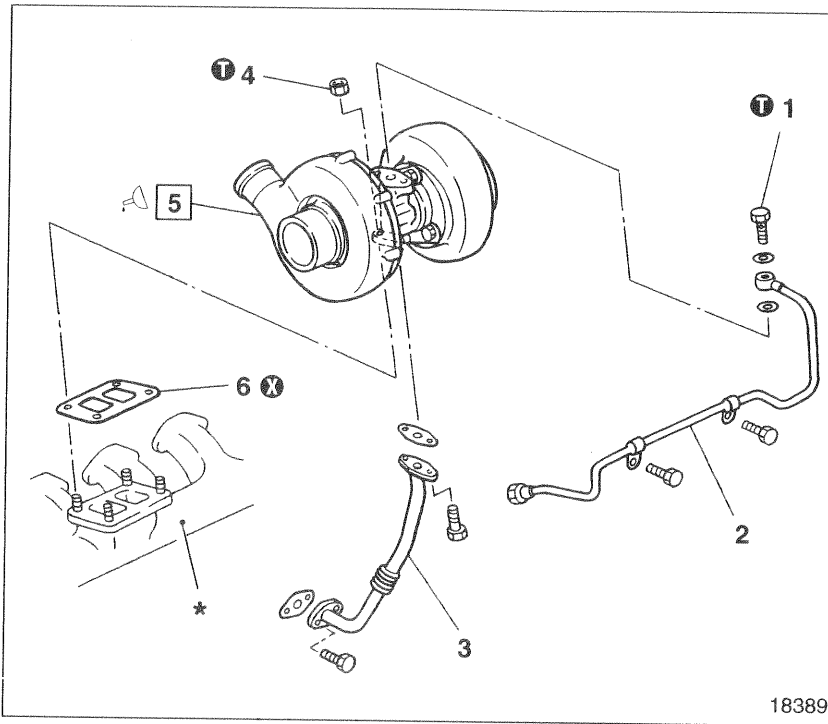

## ● Removal sequence

- 1 Eyebolt
- 2 Oil inlet pipe
- 3 Oil return pipe
- 4 Nut
- 5 Turbocharger assembly P.15-44
- 6 Gasket

\*: Exhaust manifold P.15-63, 64

ⓧ: Non-reusable part

## ● Installation sequence

Reverse the order of removal.

## ① Tightening torque

Unit: N · m {kgf · m}

Location	Parts to be tightened	Tightening torque	Remarks
1	Eyebolt (for mounting oil inlet pipe)	21 {2.1}	—
4	Nut (for mounting turbocharger assembly)	41 {4.2}	—

## ☑ Lubricant

Location	Points of application	Specified lubricant	Quantity
5	Supply when installing turbocharger assembly	Engine oil	As required

## ◆ Service procedure

### 5 Installation of turbocharger assembly

When the turbocharger assembly 5 is installed, supply engine oil from the oil hole **A** to make sure that all the parts operate smoothly.

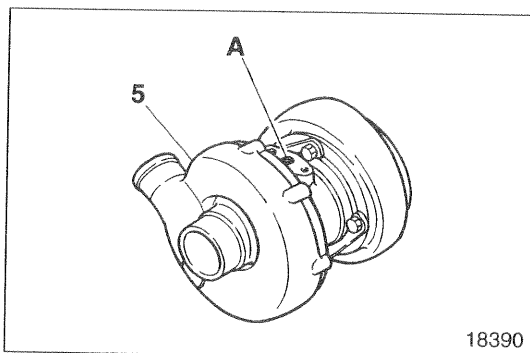

---

**MEMO**

---

# TURBOCHARGER <TF07>

## Turbocharger Assembly

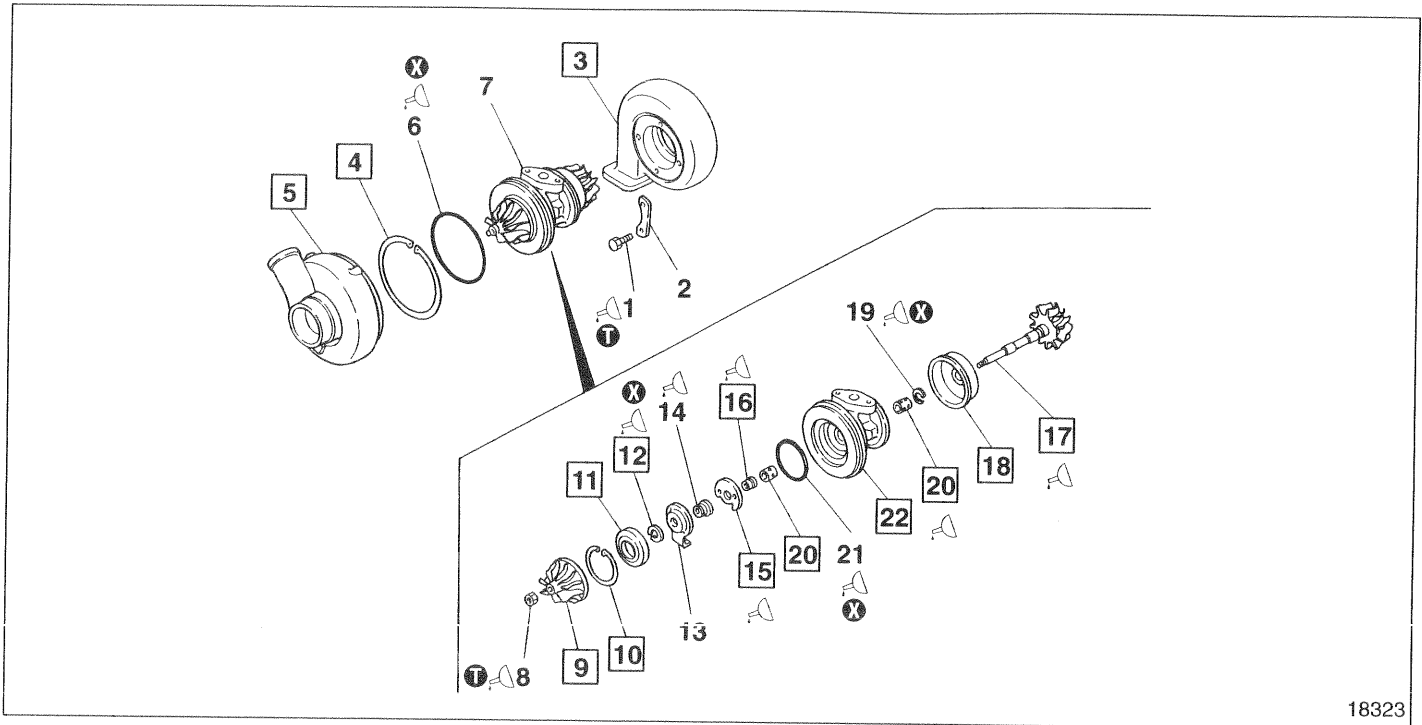

18323

### ● Operations before disassembly

📖 P.15-45

### ● Disassembly sequence

- |                                      |                          |                       |
|--------------------------------------|--------------------------|-----------------------|
| 1 Bolt                               | 9 Compressor wheel       | 18 Turbine back plate |
| 2 Lock plate                         | 10 Snap ring             | 19 Piston ring        |
| 3 Turbine housing                    | 11 Insert                | 20 Bearing            |
| 4 Snap ring                          | 12 Piston ring           | 21 O-ring             |
| 5 Compressor cover                   | 13 Oil deflector         | 22 Bearing housing    |
| 6 O-ring                             | 14 Thrust sleeve         |                       |
| 7 Wheel and bearing housing assembly | 15 Thrust bearing        | ⊗ : Non-reusable part |
| 8 Lock nut                           | 16 Thrust ring           |                       |
|                                      | 17 Shaft & turbine wheel |                       |

### CAUTION ⚠

Carefully remove piston rings 12 and 19, as they are readily broken.

### ● Cleaning after disassembly

📖 P.15-46

### ● Reassembly sequence

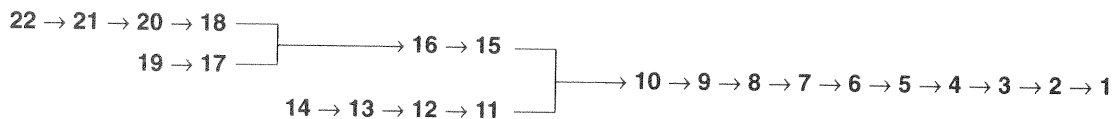

### CAUTION ⚠

Do not widen the piston rings 12 and 19 more than necessary, as they are readily broken.

### ● Inspection after reassembly

📖 P.15-46

## Service standards

Unit: mm

Location	Maintenance item		Standard value	Limit	Remedy
3, 17	Clearance between shaft & turbine wheel and turbine housing		0.55 to 0.65	—	Check
12	Clearance between open ends of piston ring (Measure the clearance of a new piston ring.)		0.05 to 0.25	—	Replace insert
17	Shaft & turbine wheel	Outside diameter of bearing journal	—	9.9962	Replace
		Bend of shaft	—	0.015	Replace
		End play	0.057 to 0.103	—	Check
17, 18	Clearance between shaft & turbine wheel back surface and turbine back plate		0.677 to 1.123	—	Check
20	Bearing	Inside diameter	—	10.0328	Replace
		Outside diameter	—	16.901	
		Length	—	11.84	
22	Bearing inserting portion inside diameter of bearing housing		—	17.006	Replace

 Tightening torque

Unit: N·m {kgf·m}

Location	Parts to be tightened	Tightening torque	Remarks
1	Bolt (for mounting lock plate)	12 to 14 {1.2 to 1.4}	—
8	Lock nut (for mounting compressor wheel)	18 to 21 {1.85 to 2.19}	—

 Lubricant

Location	Points of application	Specified lubricant	Quantity
1	Apply to threads of bolt	MOLYKOTE	As required
8	Apply to threads of lock nut	MOLYKOTE	As required
6, 12, 14 to 17, 19 to 21	Apply to all of the parts.	Engine oil	As required

## ◆ Service procedure

## ● Operations before disassembly

Make alignment marks on the turbine housing 3, compressor cover 5 and wheel & bearing housing assembly 7.

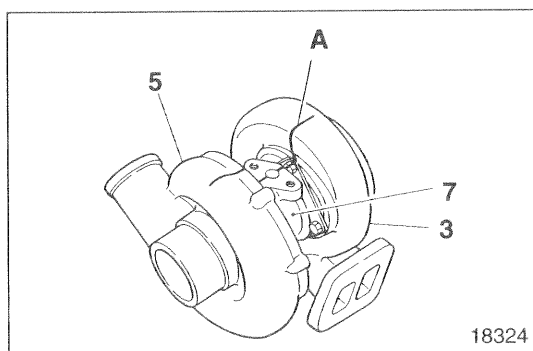

# TURBOCHARGER <TF07>

## ● Cleaning after disassembly

- Before cleaning, visually check the individual parts for burns, rubbed stains, etc. which might disappear after cleaning. If there is anything wrong, replace.
- Immerse the disassembled parts in a non-combustible solvent (DAIDO CHEMICAL INDUSTRY CO., LTD. DAI CLEANER T-30).

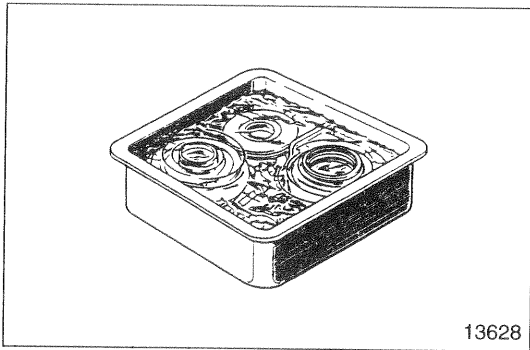

- Take out the parts from the solvent and blow compressed air **A** against them.

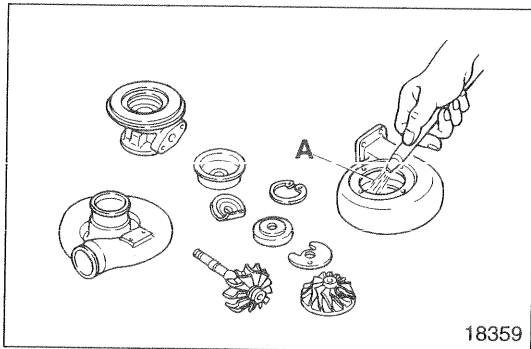

- Scrape off deposits.

**B**: Plastic scraper or stiff brush

- Re-immerses in the solvent.
- Blow compressed air **A**.

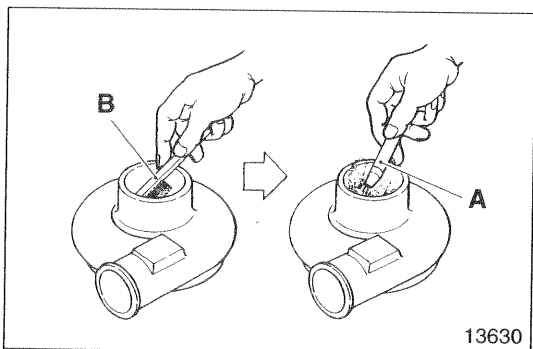

## ● Inspection after reassembly

Manually rotate the compressor wheel **9** and turbine wheel **17** to check whether they rotate smoothly.

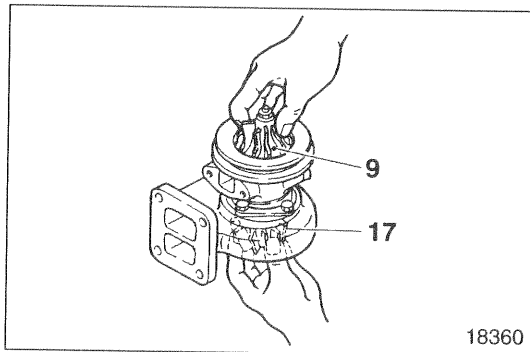

**3 Turbine housing**

[Removal]

A: Rubber hammer

**CAUTION** ⚠

- While using care to prevent damage to the turbine housing 3, lightly strike its entire circumference with a rubber hammer or similar tool.
- Since the blades of the shaft & turbine wheel 17 are readily bent, use care to make sure that they do not hit the turbine housing 3.

[Installation]

Apply MOLYKOTE to the threaded portion of the bolt 1, line up the alignment marks made before disassembly, and then tighten the bolt to the specified torque.

**CAUTION** ⚠

Use care to prevent damage to the blades of the shaft & turbine wheel 17.

**3 17 Measurement of clearance between turbine housing and shaft & turbine wheel**

If the reading exceeds the nominal value, disassemble and check to locate the cause.

**4 Installation of snap ring**

Line up the alignment marks made before disassembly and install the snap ring 4 as shown.

A: Tapered surface

**CAUTION** ⚠

When the snap ring 4 is installed, hold it by hand to make sure that it does not bounce out.

**5 Removal of compressor cover**

A: Rubber hammer

**CAUTION** ⚠

- While using care to prevent damage to the compressor cover 5, lightly strike its entire circumference with a rubber hammer A or similar tool.
- Since the blades of the compressor wheel 9 are readily bent, use care to make sure that they do not hit the compressor cover 5.

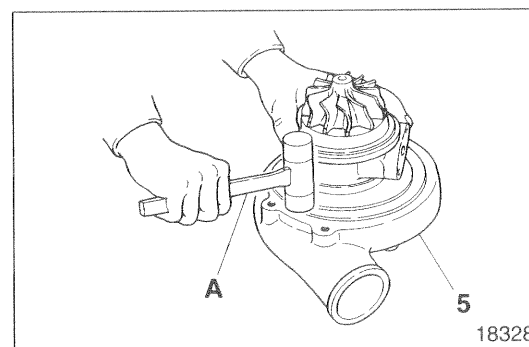
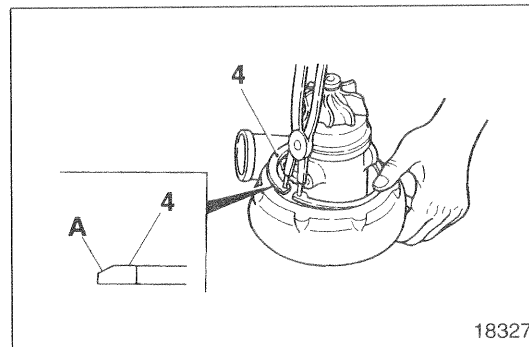
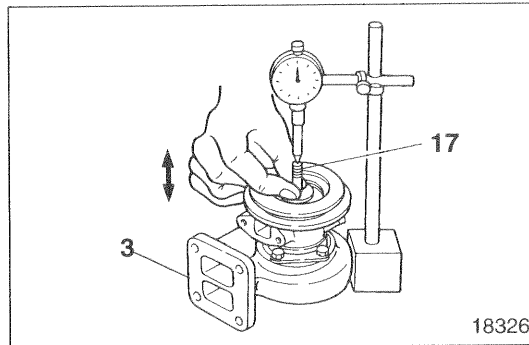
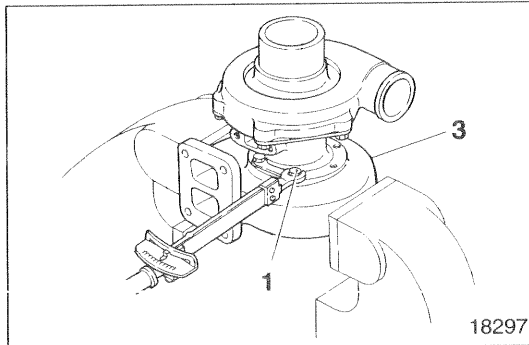
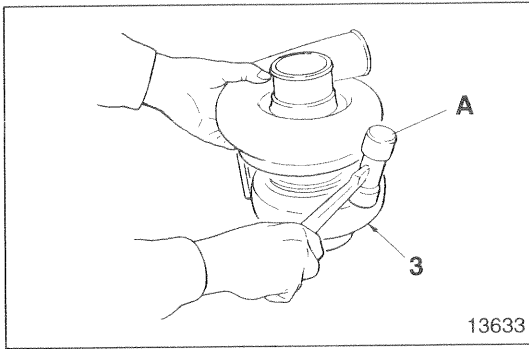

# TURBOCHARGER <TF07>

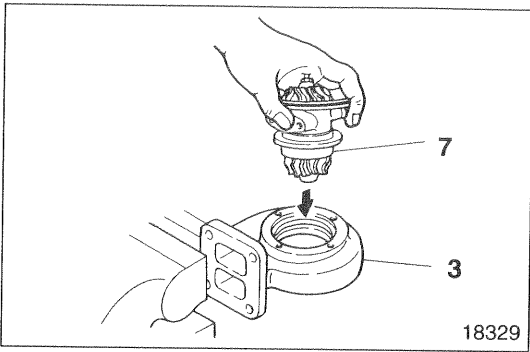

## 9 Compressor wheel

[Removal]

Hold the turbine housing 3 in a vice, and install the wheel & bearing housing assembly 7.

### CAUTION

Since the blades of the shaft & turbine wheel 17 are readily bent, make sure that they do not hit the turbine housing 3.

- While holding down the boss on the shaft & turbine wheel 17, remove the lock nut 8.

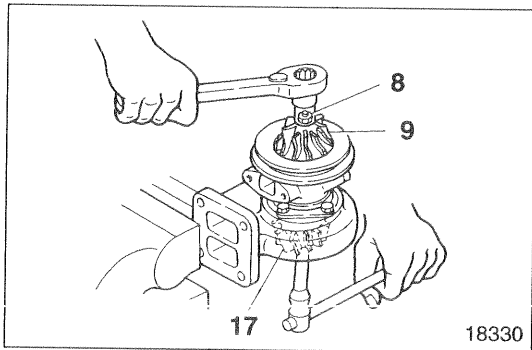

[Installation]

Hold the turbine housing 3 in a vice and install the temporarily assembly wheel & bearing housing assembly 7.

### CAUTION

Since the blades of the shaft & turbine wheel 17 are readily bent, make sure that they do not hit the turbine housing 3.

- While holding down the boss on the shaft & turbine wheel 17, apply MOLYKOTE to the threaded portion of the lock nut 8, and tighten the lock nut to the specified torque.

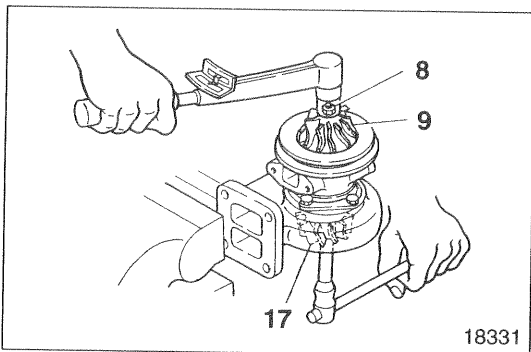
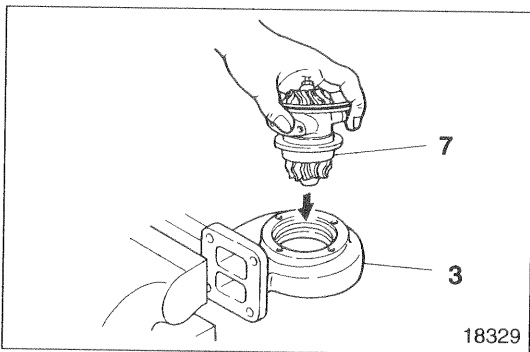

## 10 Snap ring

[Removal]

### CAUTION

When the snap ring 10 is removed, hold it by hand to make sure that it does not bounce out.

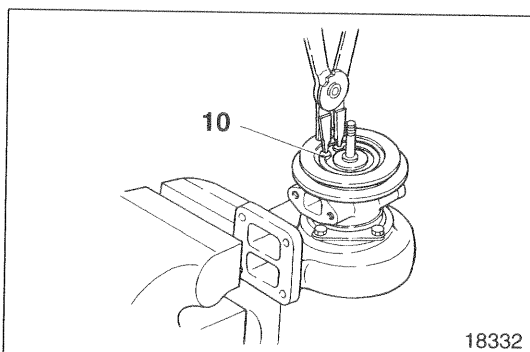

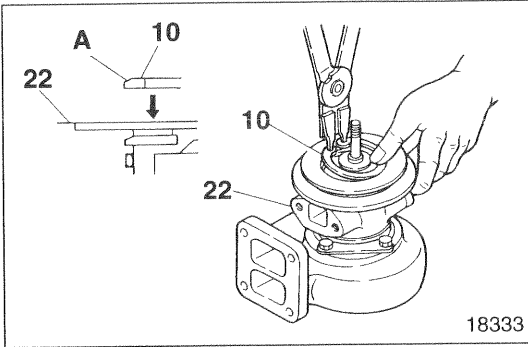

[Installation]

- Install the snap ring 10 in the illustration direction in the bearing housing 22.

A: Tapered surface

**CAUTION** ⚠

When the snap ring 10 is installed, hold it by hand to make sure that it does not bounce out.

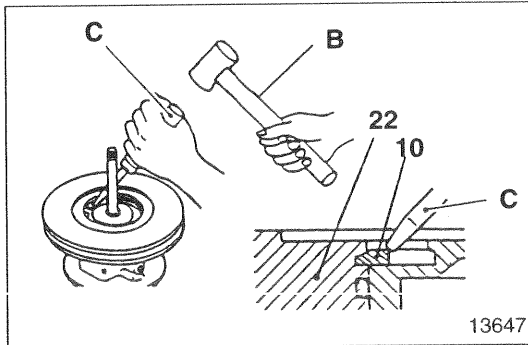

- Install the snap ring 10 securely in the groove of the bearing housing 22.

B: Hammer

C: Screwdriver

**CAUTION** ⚠

Use care to make sure that the plain screwdriver C does not hit the bearing housing 22.

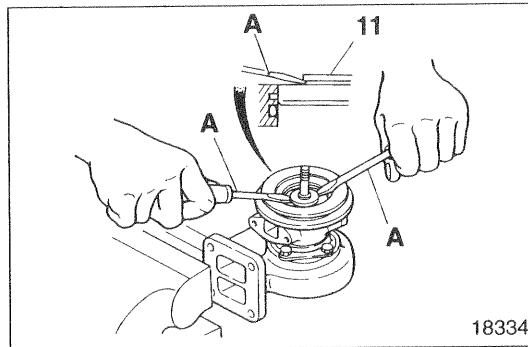

**11** Insert

[Removal]

A: Screwdriver

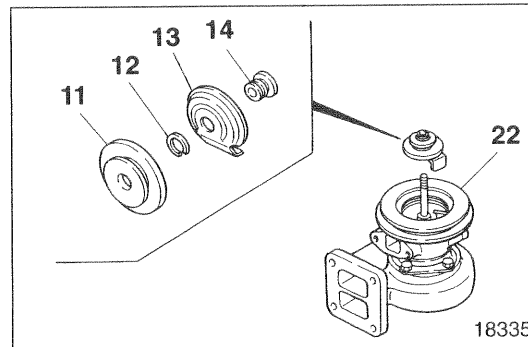

[Installation]

- Install the oil deflector 13 in the illustrated direction in the bearing housing 22.

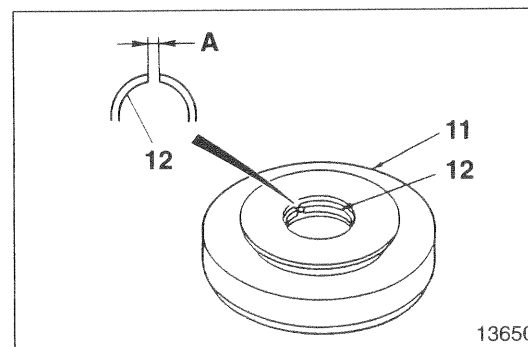

**12** Measurement of clearance between open ends of piston ring

- Mount a new piston ring 12 in the insert 11.
- Measure the clearance A between the open ends of the piston ring.
- If the reading is out of the nominal value, replace the insert 11.

# TURBOCHARGER <TF07>

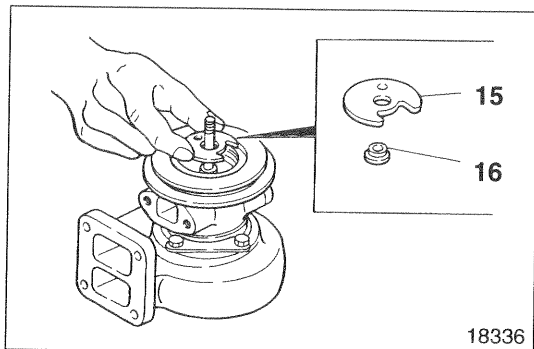

## 15 16 Installation of thrust bearing, thrust ring

Install the thrust bearing 15 and thrust ring 16 in such a way that they will be directed as shown.

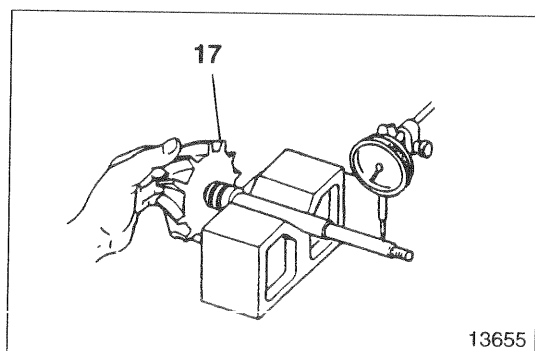

## 17 Shaft & turbine wheel

[Inspection]

### (1) Bend of shaft

- Using the dial indicator, measure at the illustrated position.
- If the reading exceeds the limit, replace the shaft & turbine wheel 17.

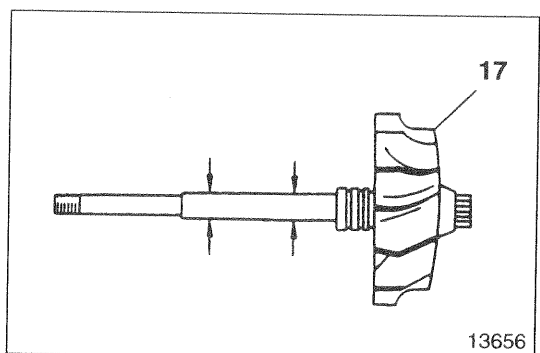

### (2) Outside diameter of journal

If the reading exceeds the limit, replace the shaft & turbine wheel 17.

### (3) Rough journal

If the journal is rough, repair by the following procedures.

[Repair]

- Install the shaft & turbine wheel 17 on a lathe with both centers supported.
- Lightly grind the journal through use of emery paper #400 and engine oil.

## CAUTION

After the journal has been ground, be sure to measure the outside diameter of the journal.

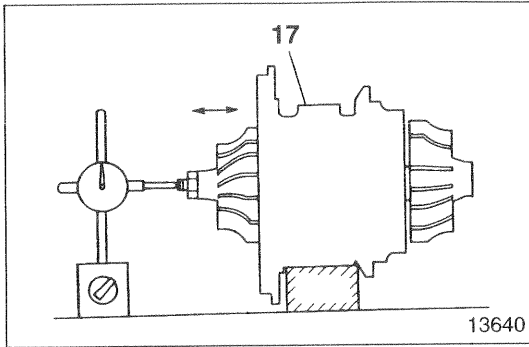
**(4) End play**

If the reading exceeds the nominal value, disassemble and check to locate the cause.

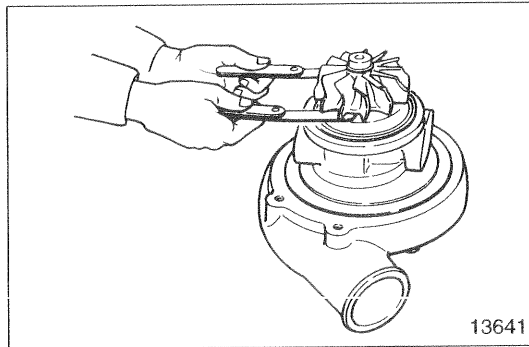
**17 18 Clearance between shaft & turbine wheel back surface and turbine back plate**

- Using two thickness gauges, measure the clearance at the end of blade.
- If any reading exceeds the nominal value, disassemble and check to locate the cause.

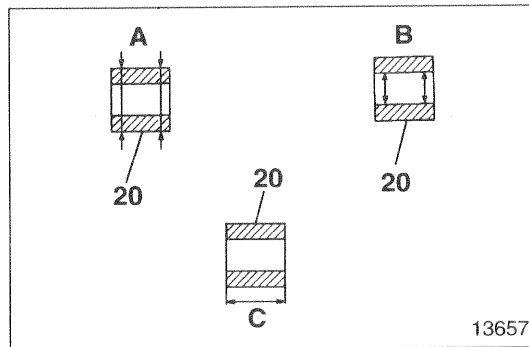
**20 Inspection of bearing**

- Measure at the illustrated position

A : Outside diameter

B : Inside diameter

C : Length

- If any reading exceeds the limit, replace the bearing 20.

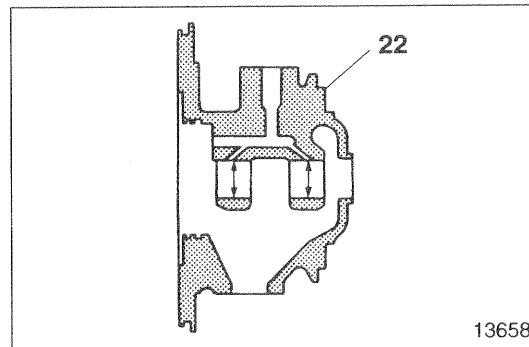
**22 Inspection of bearing housing**

- Measure the inside diameter of the bearing 20 mounting portion.
- If the reading exceeds the limit, replace the bearing housing 22.

# INTERCOOLER <6D16-TL, 16-TLE>

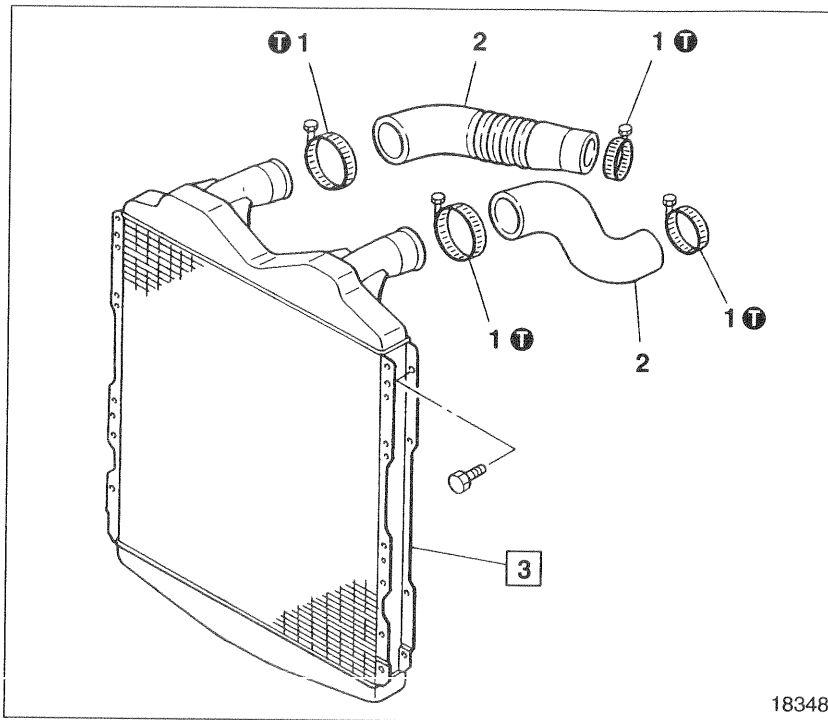

## ● Disassembly sequence

- 1 Clamp
- 2 Rubber hose
- 3 Intercooler

## ● Reassembly sequence

Reverse the order of disassembly.

## Service standards

Location	Maintenance item	Standard value	Limit	Remedy
3	Intercooler (air leak at the air pressure of 150 kPa {1.5 kgf/cm <sup>2</sup> })	0 cm <sup>3</sup> {0 mL}	—	Replace

## ⓘ Tightening torque

Unit: N · m {kgf · m}

Location	Parts to be tightened	Tightening torque	Remarks
1	Clamp (for mounting rubber hose)	4.9 to 9.8 {0.5 to 1.0}	—

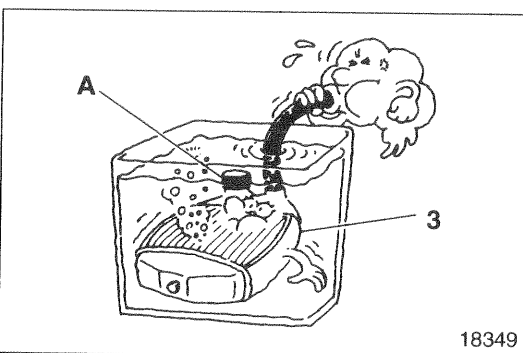

## ◆ Service procedure

### 3 Inspection of intercooler

Put a cap **A** on either of the air ports of the intercooler **3** and connect a hose to the other, immerse the intercooler **3** in a water tank, and apply the standard pressure from the hose side to check for air leaks.

If there are air leaks, replace the intercooler.

---

**M E M O**

---

# INTAKE MANIFOLD <6D14, 16, 16-E>

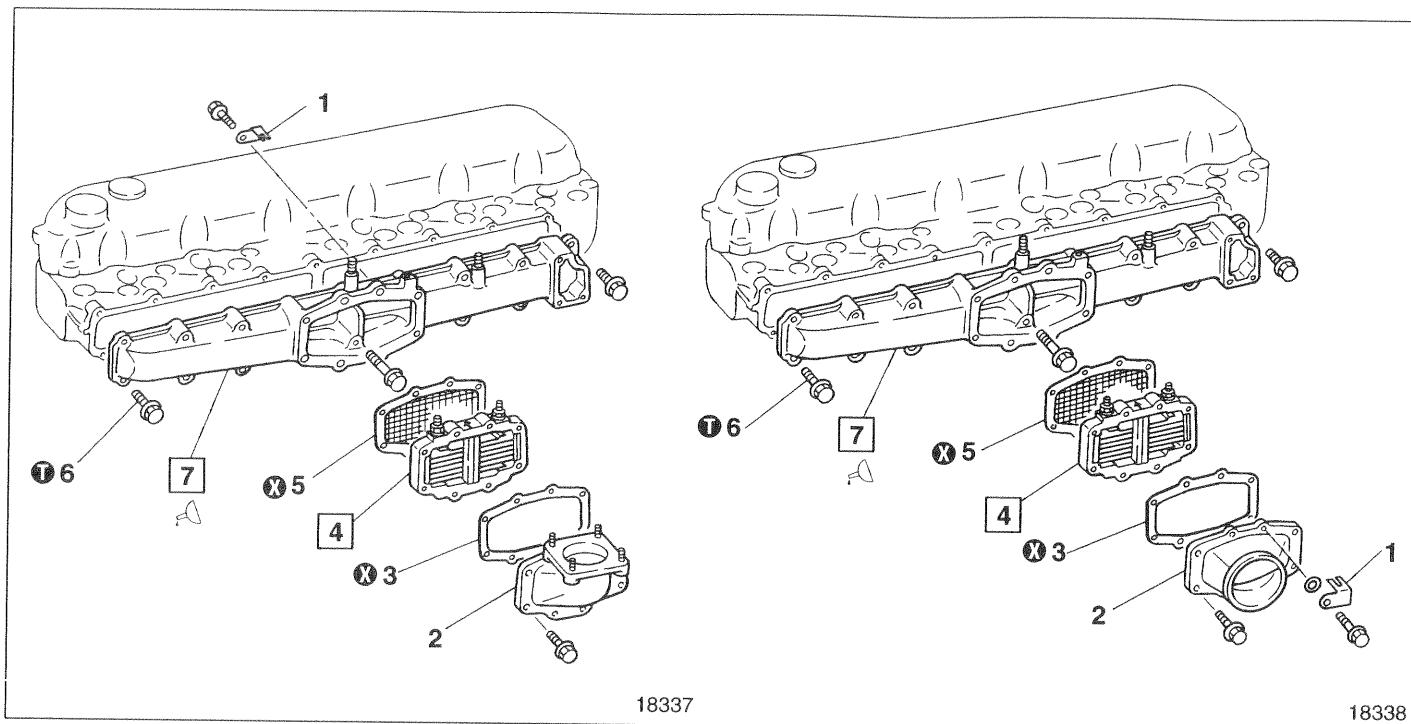

## ● Disassembly sequence

- 1 Earth plate
- 2 Coupler
- 3 Gasket
- 4 Air heater
- 5 Gasket

- 6 Bolt
- 7 Intake manifold

⊗ : Non-reusable part

## ● Reassembly sequence

Reverse the order of removal.

## ⓘ Tightening torque

Unit: N·m {kgf·m}

Location	Parts to be tightened	Tightening torque	Remarks
6	Bolt (for mounting intake manifold)	23 {2.37}	—

## 🔧 Sealants

Location	Points of application	Kinds	Quantity
7	Apply to cylinder head mounting surface of the intake manifold	ThreeBond 1207B	As required

## ◆ Service procedure

### 4 Installation of air heater

The air heater 4 should be installed with its arrow mark **A** directed toward the intake manifold 7.

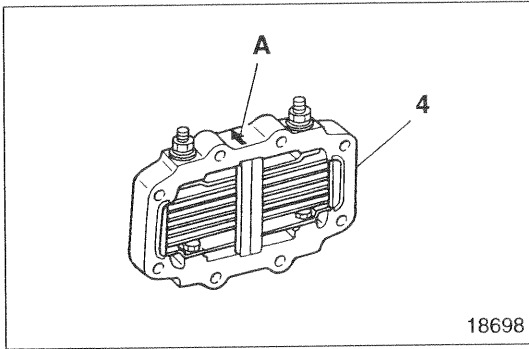

### 7 Installation of intake manifold

- The intake manifold is installed by use of either a seat gasket or sealant. This section describes the procedures for installation by use of a sealant.
- Apply sealant **A** evenly without a break to the cylinder head mounting surface of the intake manifold 7.
- Install the intake manifold on the cylinder head in less than three minutes after application of sealant **A**.

#### CAUTION

- Thoroughly clean the sealant applying surface of the intake manifold 7 beforehand.
- When the intake manifold 7 is installed, make sure that it is not out of alignment.
- When the manifold mounting bolt 6 was loosened, be sure to re-apply sealant **A** to the intake manifold 7.
- Do not start the engine in less than an hour after installation.

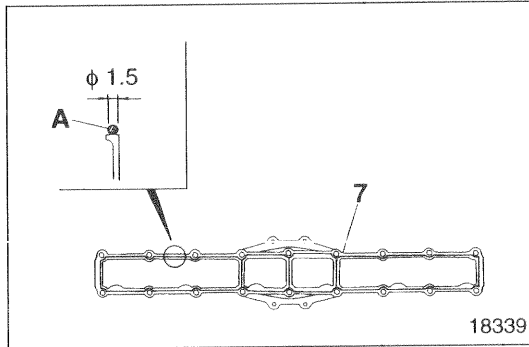

# INTAKE MANIFOLD <6D14-T, 15-T, 16-T, 16-TE>

## <Exhaust outlet forward specification>

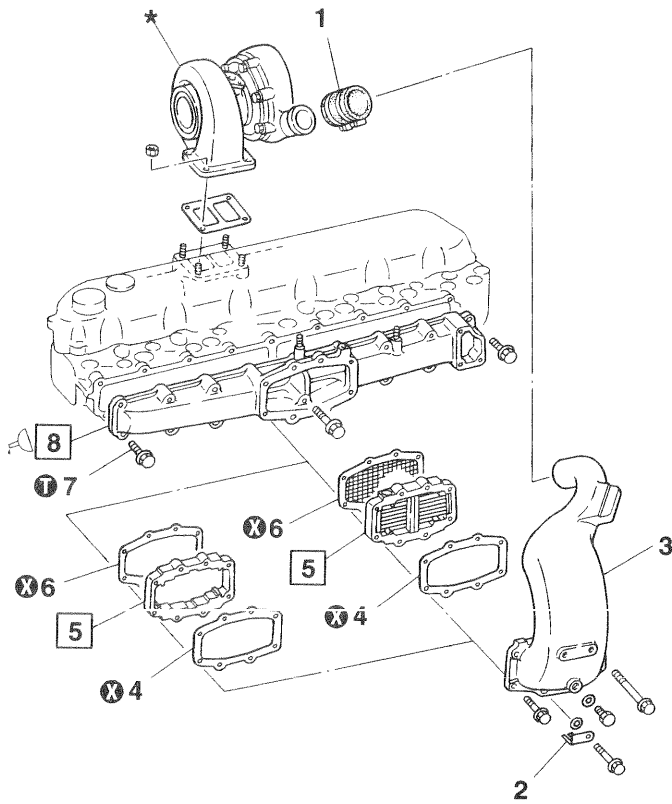

18340

## ● Disassembly sequence

- 1 Rubber hose
- 2 Earth plate <with air heater>
- 3 Air inlet pipe
- 4 Gasket
- 5 Air heater <with air heater>  
Spacer <without air heater>
- 6 Gasket
- 7 Bolt
- 8 Intake manifold

\*: Turbocharger assembly

☞ P.15-20

⊗: Non-reusable part

## ● Reassembly sequence

Reverse the order of disassembly.

## <Exhaust outlet rearward specification>

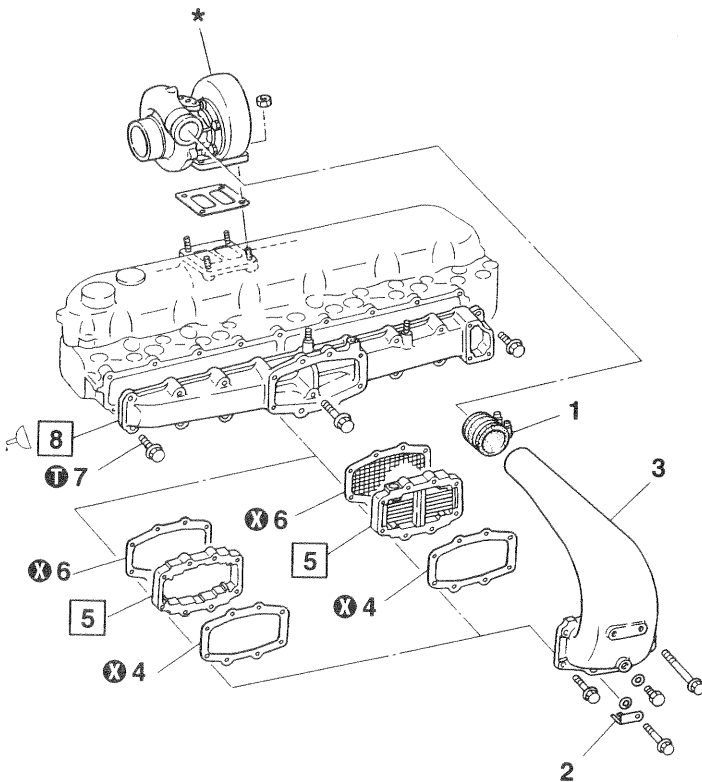

18341

## ① Tightening torque

Unit: N · m {kgf · m}

Location	Parts to be tightened	Tightening torque	Remarks
7	Bolt (for mounting intake manifold)	19 {1.9}	—

## 🔊 Sealant

Location	Points of application	Specified sealant	Quantity
8	Apply to cylinder head mounting surface of the intake manifold	ThreeBond 1207B	As required

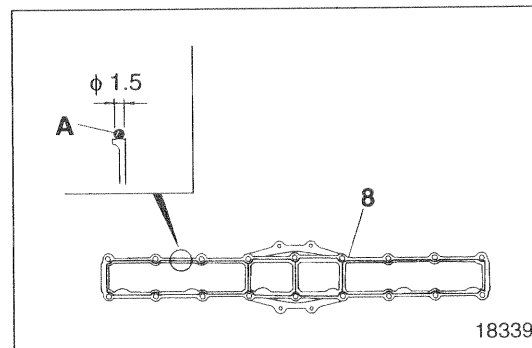
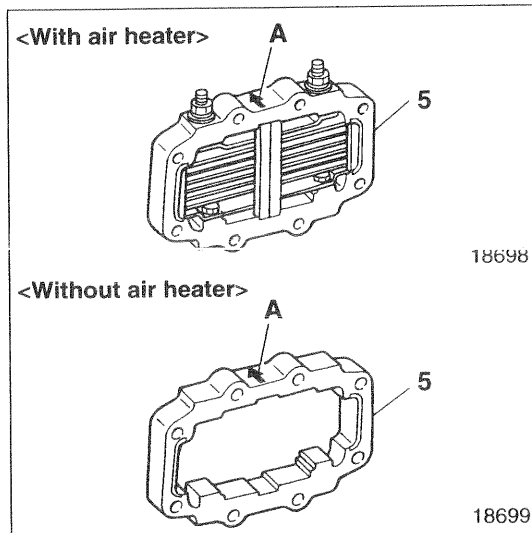

## ◆ Service procedure

### 5 Installation of air heater or spacer

The air heater 5 or the spacer 5 should be installed with its arrow mark **A** directed toward the intake manifold 8.

### 8 Installation of intake manifold

- The intake manifold 8 is installed by use of either a seat gasket or sealant. This section describes the procedures for installation by use of a sealant.
- Apply sealant **A** evenly without a break to the cylinder head mounting surface of the intake manifold 8.
- Install the intake manifold 8 on the cylinder head in less than three minutes after application of sealant **A**.

### CAUTION ⚠

- Thoroughly clean the sealant applying surface of the intake manifold 8 beforehand.
- When the intake manifold 8 is installed, make sure that it is not out of alignment.
- When the manifold mounting bolt 7 was loosened, be sure to re-apply sealant **A** to the intake manifold 8.
- Do not start the engine in less than an hour after installation.

# INTAKE MANIFOLD <6D16-TL>

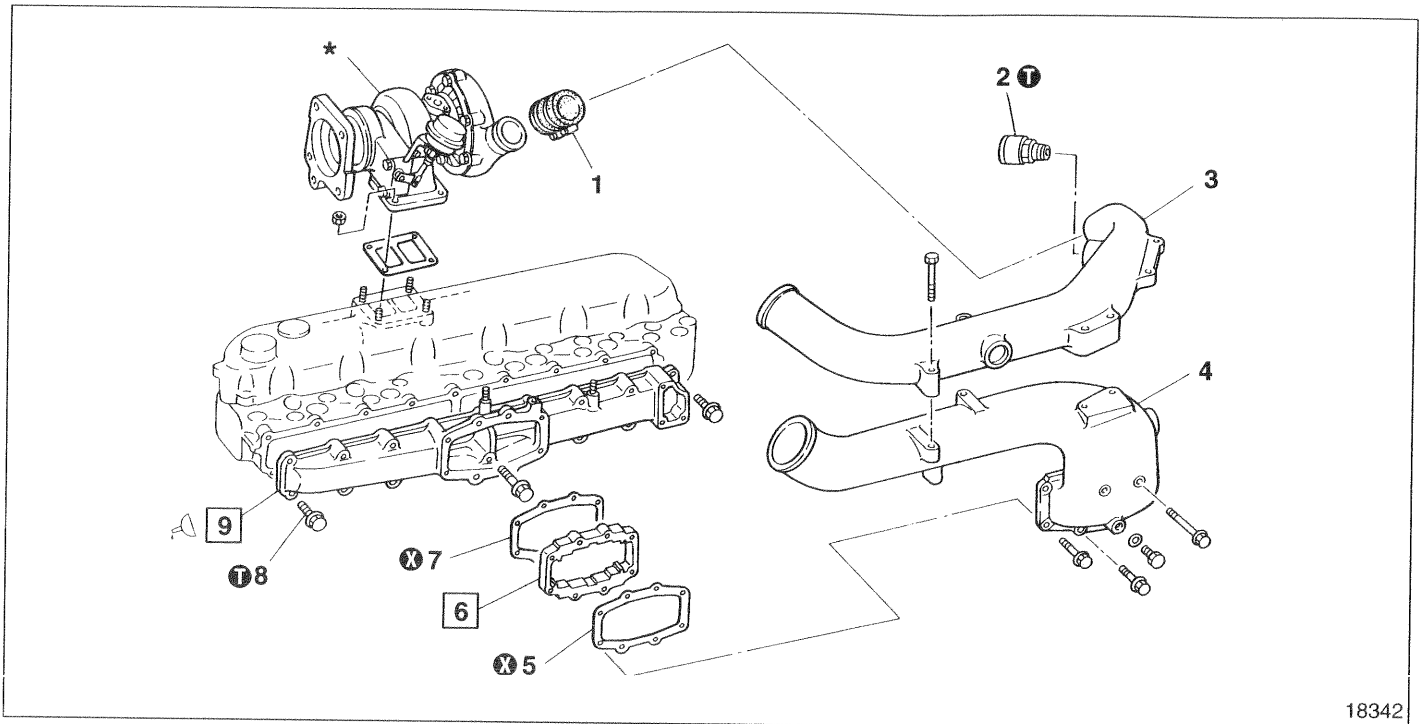

18342

## ● Disassembly sequence

- 1 Rubber hose
- 2 Overboost valve
- 3 Air inlet pipe
- 4 Air inlet pipe
- 5 Gasket
- 6 Spacer
- 7 Gasket

- 8 Bolt
- 9 Intake manifold

\*: Turbocharger assembly

☞ P.15-30

⊗: Non-reusable part

## ● Reassembly sequence

Reverse the order of disassembly.

## ① Tightening torque

Unit: N · m {kgf · m}

Location	Parts to be tightened	Tightening torque	Remarks
2	Overboost valve	31 {3.2}	—
8	Bolt (for mounting intake manifold)	23 {2.37}	—

## ☞ Sealant

Location	Points of application	Specified sealant	Quantity
9	Apply to cylinder head mounting surface of the intake manifold	ThreeBond 1207B	As required

## ◆ Service procedure

### 6 Installation of spacer

The spacer **6** should be installed with its arrow mark **A** directed toward the intake manifold **9**.

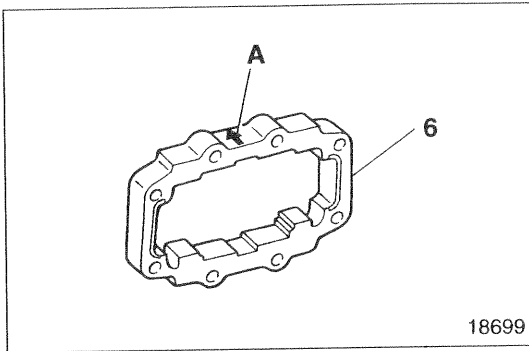

### 9 Installation of intake manifold

- The intake manifold **9** is installed by use of either a seat gasket or sealant. This section describes the procedures for installation by use of a sealant.
- Apply sealant **A** evenly without a break to the cylinder head mounting surface of the intake manifold **9**.
- Install the intake manifold **9** on the cylinder head in less than three minutes after application of sealant **A**.

### CAUTION

- Thoroughly clean the sealant applying surface of the intake manifold **9** beforehand.
- When the intake manifold **9** is installed, make sure that it is not out of alignment.
- When the manifold mounting bolt **8** was loosened, be sure to re-apply sealant **A** to the intake manifold **9**.
- Do not start the engine in less than an hour after installation.

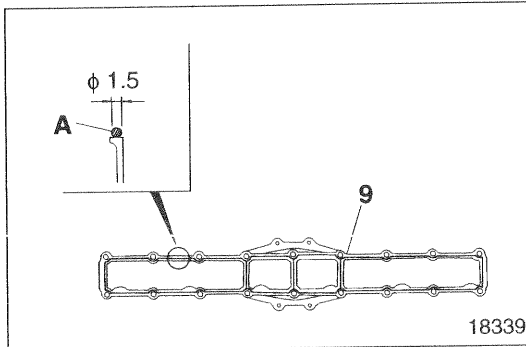

# INTAKE MANIFOLD <6D16-TLE>

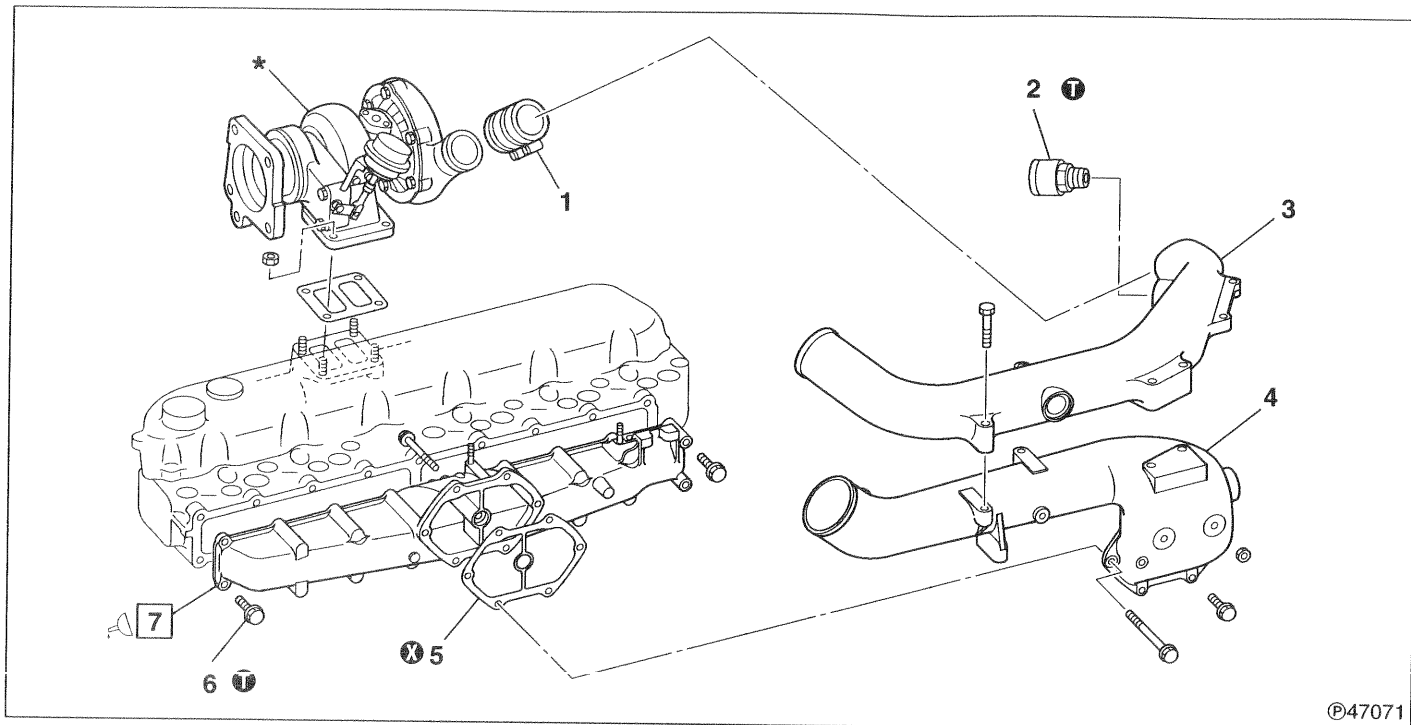

©47071

## ● Disassembly sequence

- |                   |                   |
|-------------------|-------------------|
| 1 Rubber hose     | 6 Bolt            |
| 2 Overboost valve | 7 Intake manifold |
| 3 Air inlet pipe  |                   |
| 4 Air inlet pipe  |                   |
| 5 Gasket          |                   |

\*: Turbocharger assembly

📖 P.15-30

⊗: Non-reusable part

## ● Reassembly sequence

Reverse the order of disassembly.

## ⓘ Tightening torque

Unit: N·m {kgf·m}

Location	Parts to be tightened	Tightening torque	Remarks
2	Overboost valve	31 {3.2}	—
6	Bolt (for fitting intake manifold)	23 {2.37}	—

## 🔧 Sealant

Location	Points of application	Specified sealant	Quantity
7	Apply to cylinder head mounting surface of intake manifold	ThreeBond 1207B	As required

## ◆ Service procedure

### 7 Installation of intake manifold

- Apply sealant **A** evenly without a break to the cylinder head mounting surface of the intake manifold **7**.
- Install the intake manifold **7** on the cylinder head in less than three minutes after application of sealant **A**.

### CAUTION

- Thoroughly clean the sealant applying surface of the intake manifold **7** beforehand.
- When the intake manifold **7** is installed, make sure that it is not out of alignment.
- When the manifold mounting bolt **6** was loosened, be sure to re-apply sealant **A** to the intake manifold **7**.
- Do not start the engine in less than an hour after installation.

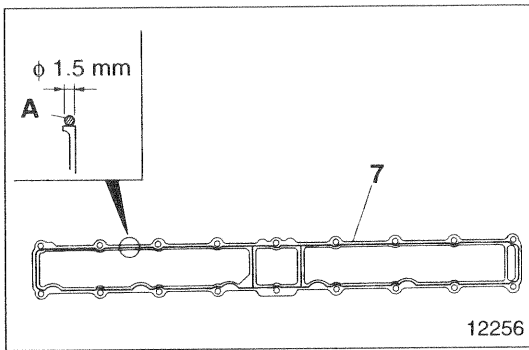

# EXHAUST MANIFOLD <6D14, 16, 16-E>

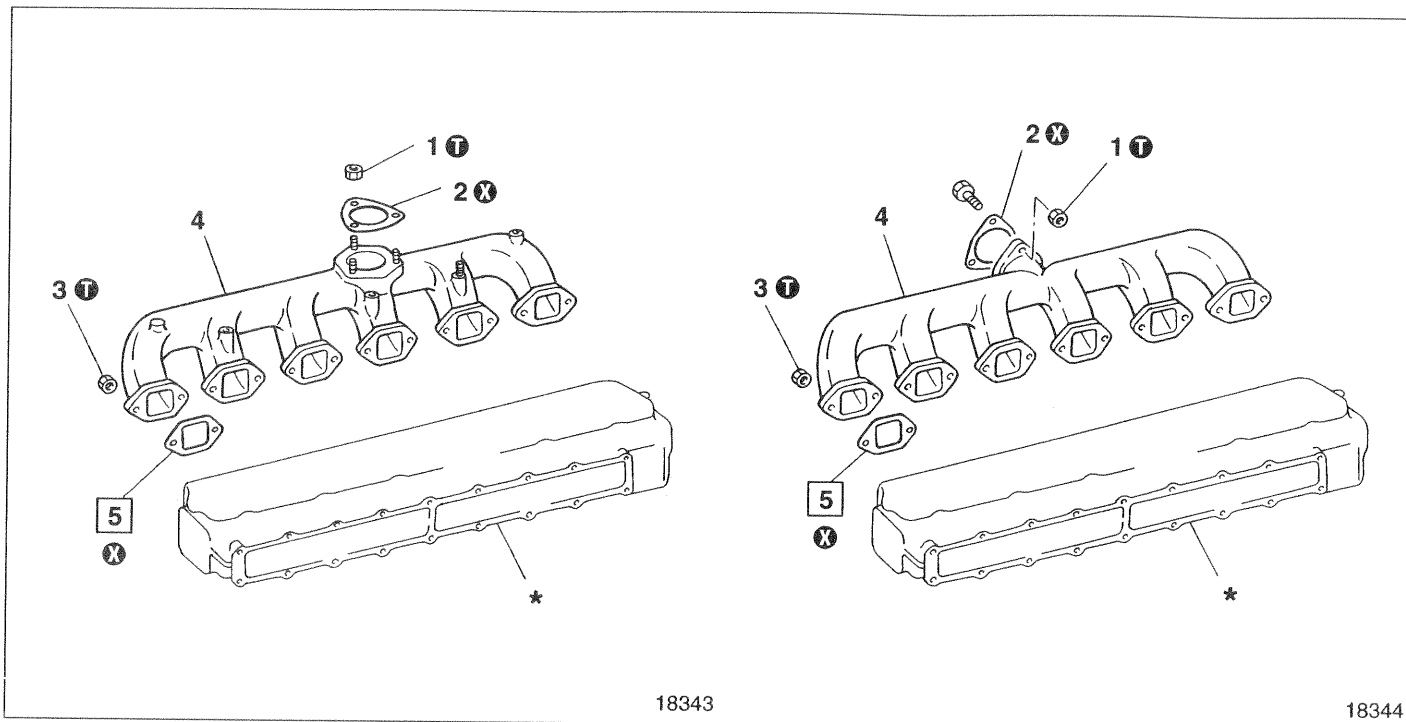

## ● Disassembly sequence

- 1 Nut
- 2 Gasket
- 3 Nut
- 4 Exhaust manifold

5 Gasket

\*: Cylinder head Gr.11

⊗: Non-reusable part

## ● Reassembly sequence

Reverse the order of disassembly.

## ⓘ Tightening torque

Unit: N·m {kgf·m}

Location	Parts to be tightened	Tightening torque	Remarks
1	Nut (for mounting exhaust pipe)	41 {4.2}	—
3	Nut (for mounting exhaust manifold)	58 {5.9}	—

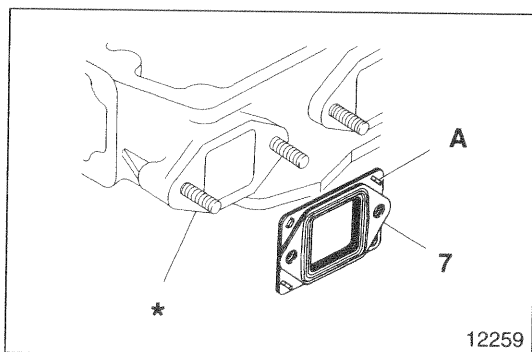

## ◆ Service procedure

### 5 Installation of gasket

Install the gasket 5 with the grommet fold-back portion **A** toward the cylinder head.

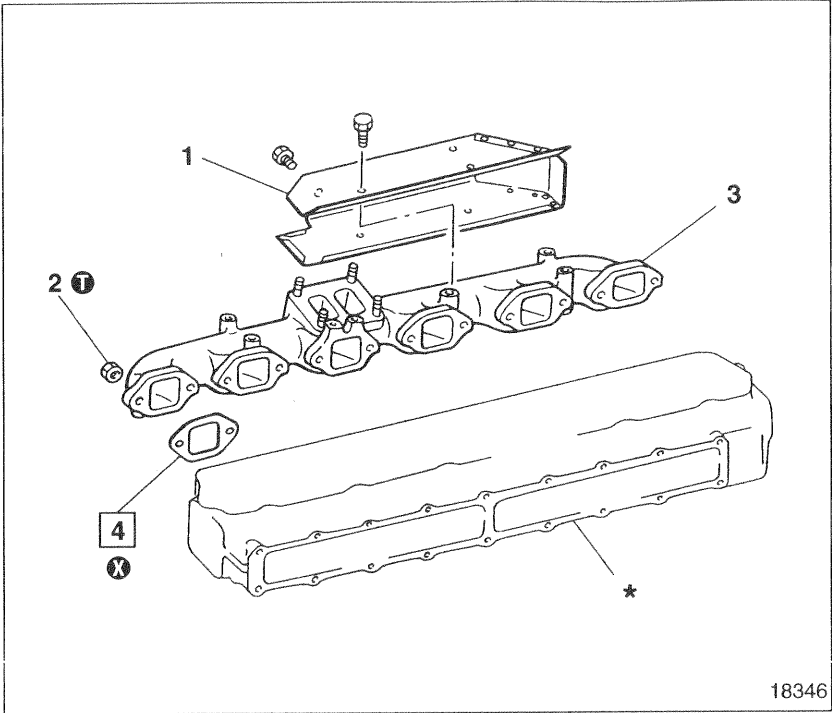

● Disassembly sequence

- 1 Cover
- 2 Nut
- 3 Exhaust manifold
- 4 Gasket

\*: Cylinder head Gr.11

⊗: Non-reusable part

● Reassembly sequence

Reverse the order of disassembly.

18346

ⓘ Tightening torque

Unit: N · m {kgf · m}

Location	Parts to be tightened	Tightening torque	Remarks
2	Nut (for mounting exhaust manifold)	58 {5.9}	—

◆ Service procedure

4 Installation of gasket

Install the gasket 4 with the grommet fold-back portion A toward the cylinder head.

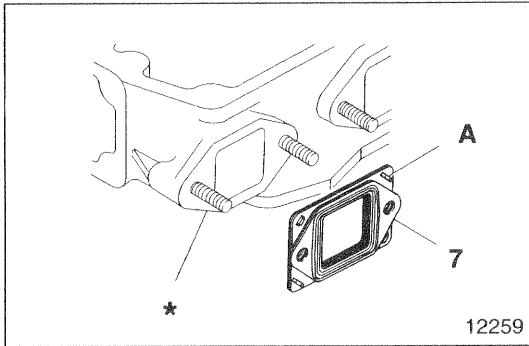

12259

# EXHAUST MANIFOLD <6D14-T, 16-T, 16-TE, 16-TL, 16-TLE>

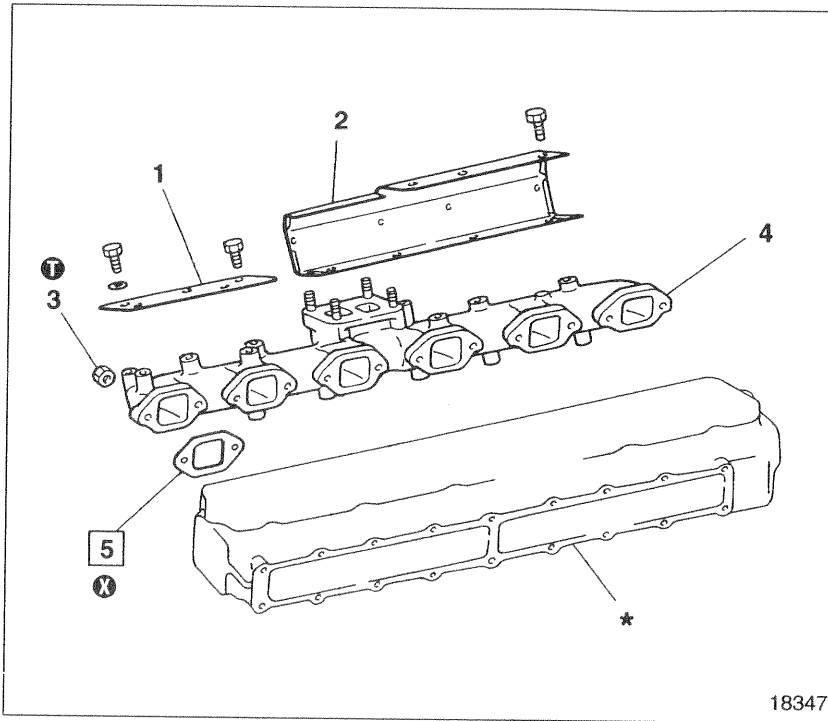

## ● Disassembly sequence

- 1 Front insulator
- 2 Rear insulator
- 3 Nut
- 4 Exhaust manifold
- 5 Gasket

\*: Cylinder head Gr.11

⊗: Non-reusable part

## ● Reassembly sequence

Reverse the order of disassembly.

## ① Tightening torque

Unit: N · m {kgf · m}

Location	Parts to be tightened	Tightening torque	Remarks
3	Nut (for mounting exhaust manifold)	58 {5.9}	—

## ◆ Service procedure

### ⑤ Installation of gasket

Install the gasket 5 with the grommet fold-back portion **A** toward the cylinder head.

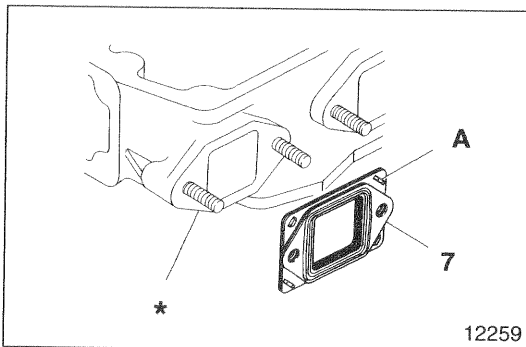

# GROUP 54 ELECTRICAL SYSTEM

<b>SPECIFICATIONS</b> .....	<b>54-2</b>
<b>STRUCTURE AND OPERATION</b>	
1. Circuit Diagram .....	54-4
2. Alternator .....	54-7
3. Charging Circuit .....	54-16
4. Starter .....	54-18
5. Preheating Circuit .....	54-21
6. Engine Starter Circuit .....	54-22
7. Safety Relay .....	54-23
8. Automatic Stop System .....	54-24
<b>TROUBLESHOOTING</b> .....	<b>54-32</b>
<b>ON-VEHICLE INSPECTION AND ADJUSTMENT</b>	
1. Inspection of Preheater System .....	54-34
2. Inspection of Safety Relay .....	54-34
3. Automatic Stop System .....	54-39
<b>ALTERNATOR</b>	
<24V-35A> .....	54-46
<24V-80A (with brush)> .....	54-54
<12V-60A> .....	54-62
<24V-40A (with vacuum pump)> .....	54-70
<24V-40A (without vacuum pump)> .....	54-78
<24V-50A> .....	54-84
<24V-80A (brushless)> .....	54-90
<24V-90A> .....	54-96
<12V-80A> .....	54-102
<b>STARTER</b>	
<24V-5kW> .....	54-108
<24V-6kW> .....	54-121
<12V-5kW> .....	54-132
<b>PREHEATER CIRCUIT</b> .....	<b>54-146</b>
<b>ENGINE STARTER CIRCUIT</b> .....	<b>54-149</b>
<b>AUTOMATIC STOP SYSTEM</b>	
• Shutdown .....	54-150
• Run-on .....	54-154

# SPECIFICATIONS

Item		Specifications													
Alternator	Manufacturer	MITSUBISHI ELECTRIC CORP.													
	Type	Alternator with built-in regulator, fan internally mounted type		Alternator with built-in regulator, fan externally mounted type											
		With brush				Brushless									
	Vacuum pump	Not provided				Pro-vided	Not provided								
	Model	A3TN 5379	A3TN 5386	A6T7 6086	A2T3 2386	A4TU 3186	A4T4 0286	A4T4 0299	A4T4 0379	A4T4 0386	A4T4 0399	A4T7 0099	A4T7 0199	A4TU 0286	
	Output (V-A)	24-35		24- 80	12- 60	24-40			24-50			24- 80	24- 90	12- 80	
Starter	Manufacturer	MITSUBISHI ELECTRIC CORP.													
	Model	M8T60071			M8T60073	M5T50179			M9T50071						
	Output (V-kW)	24-5				24-6			12-5						
	Magnet switch operating voltage (V)	16 or less						8 or less							
Starter relay	Model	U1T35383				U1X15076									
	Exciting current (V-A)	24-2.3				12-4									
	Closed magnetic voltage (V)	16 or less				8 or less									
	Opened magnetic voltage (V)	4 or less				3.5 or less									
	Allowable breaking voltage (V)	200				200									
Intake air heater	Manufacturer	Hiyoshi Denso													
	Voltage - capacity (V-kW)	22-1.83			22-2.9			11-1.83							
	Fuse capacity (A)	-			127			-							
Heater relay	Manufacturer	MITSUBISHI ELECTRIC CORP.													
	Model	U1T31382			U1T31383			U1T31384			U1T11373				
	Voltage - current (V-A)	24-2.3									12-4				
	Fuse capacity (A)	91			127			164			127				

Item		Specifications	
Glow plug	Type	Sheathed type	
	Voltage – current (V–A)	23–3	
Glow relay	Model	U1T06670	
	Voltage – current (V–A)	24–2.3	
	Fuse capacity (A)	127	
Safety relay	Model	R8T30174	R8T30175
Stop solenoid	Manufacturer	Kimura Yoko	DENSO
	Kind	Shut-down type	Run-on type
	Type	Electromagnetic type	
Solenoid relay	Manufacturer	Nikko Denki	
	Kind	Shut-down type	Run-on type
	Model	24V	0-25000-5592
		12V	0-25000-6361
			0-25000-6720
			0-25000-6990

# STRUCTURE AND OPERATION

## 1. Circuit Diagram

### <24V (Air Heater) Specification>

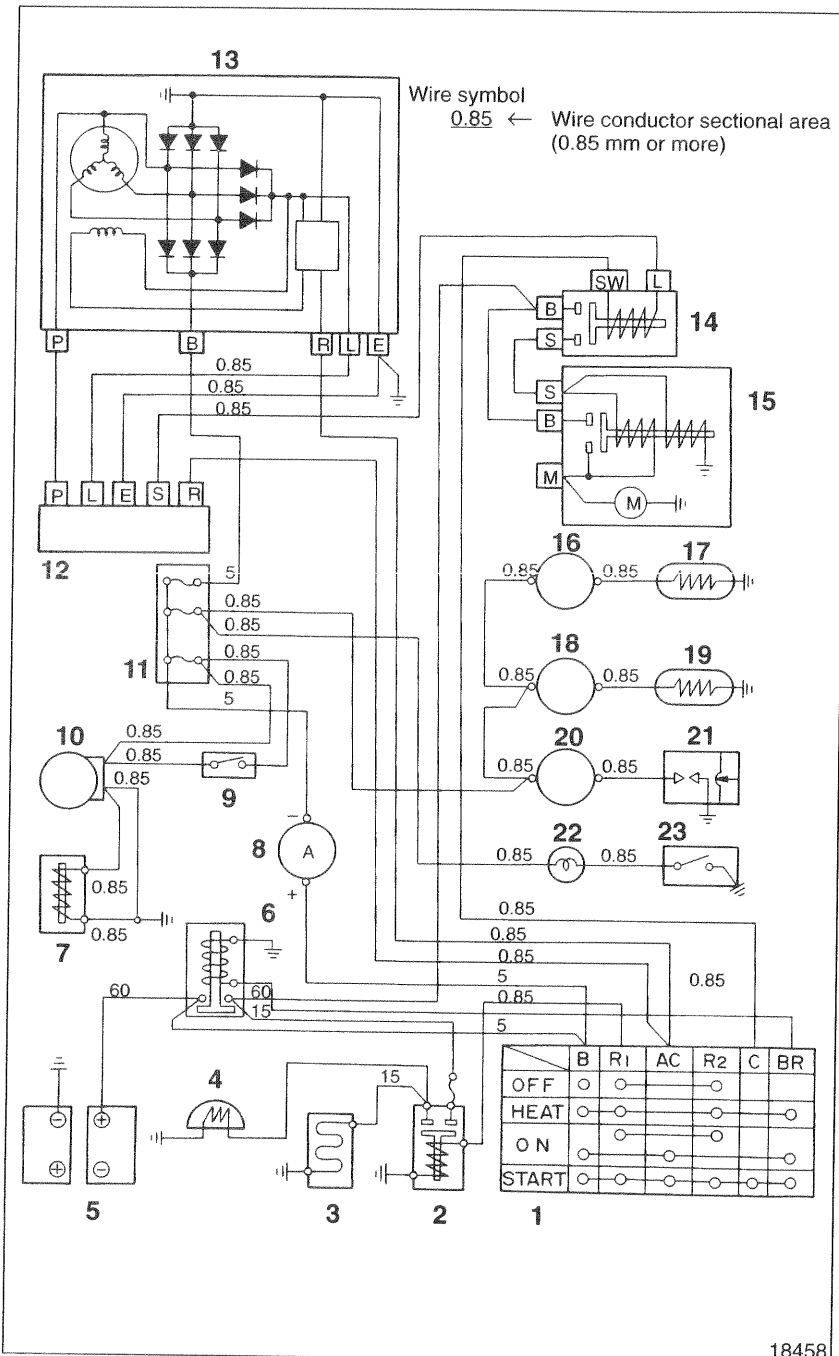

- 1 Starter switch
- 2 Heater relay
- 3 Air heater
- 4 Heater indicator
- 5 Battery
- 6 Battery relay
- 7 Tachometer sensor
- 8 Ammeter
- 9 Lamp switch
- 10 Tachometer
- 11 Fuse box
- 12 Safety relay
- 13 Alternator
- 14 Starter relay
- 15 Starter
- 16 Thermometer (for oil)
- 17 Thermo sending unit
- 18 Thermometer (for coolant)
- 19 Thermo sending unit
- 20 Oil pressure gauge
- 21 Oil pressure gauge unit
- 22 Warning lamp
- 23 Oil bypass alarm switch

- B:** Terminal B  
**E:** Terminal E  
**L:** Terminal L  
**M:** Terminal M  
**P:** Terminal P  
**R:** Terminal R  
**S:** Terminal S  
**SW:** Terminal SW

18458

<24V (Glow Plug) Specification>

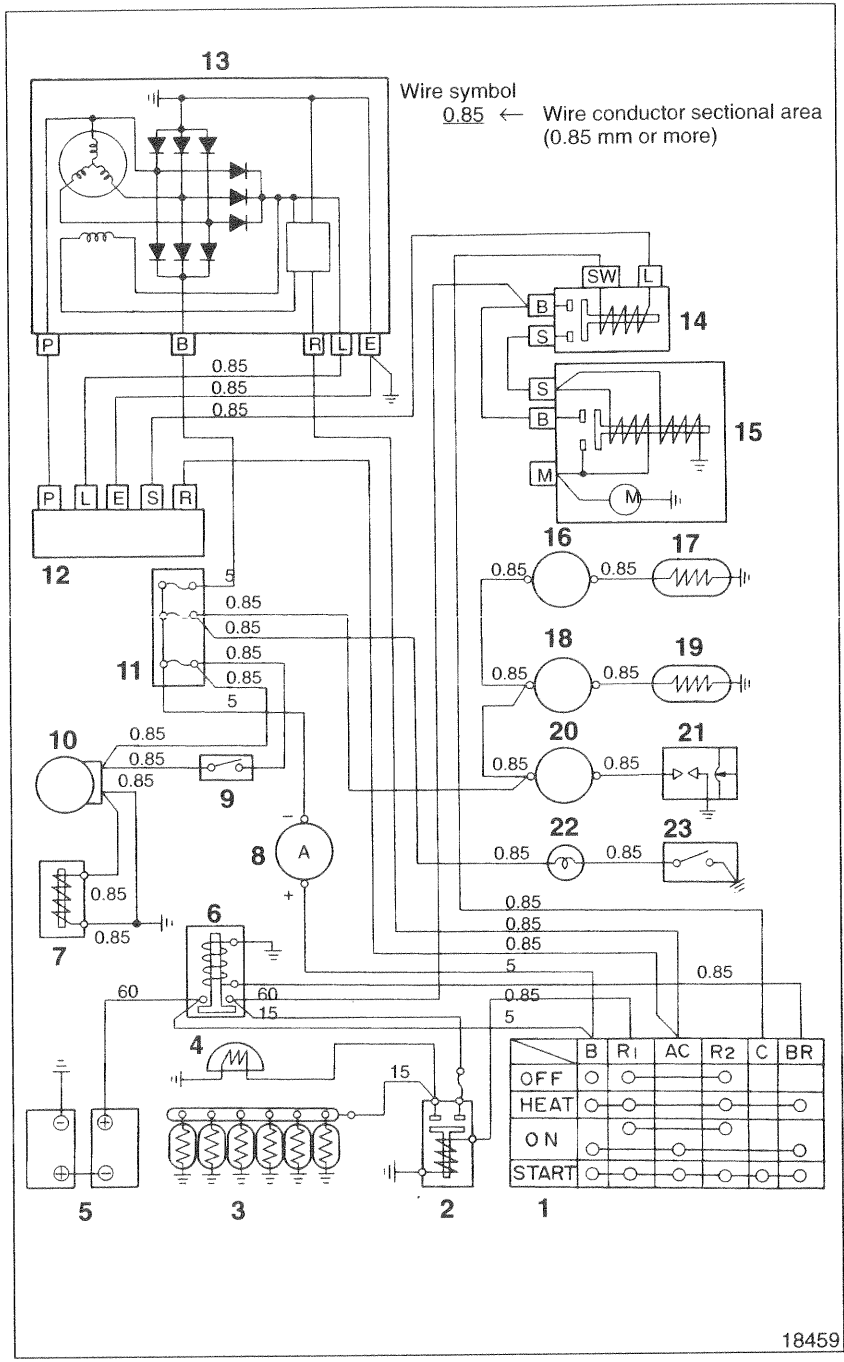

- 1 Starter switch
- 2 Glow relay
- 3 Glow plug
- 4 Glow indicator
- 5 Battery
- 6 Battery relay
- 7 Tachometer sensor
- 8 Ammeter
- 9 Lamp switch
- 10 Tachometer
- 11 Fuse box
- 12 Safety relay
- 13 Alternator
- 14 Starter relay
- 15 Starter
- 16 Thermometer (for oil)
- 17 Thermo sending unit
- 18 Thermometer (for coolant)
- 19 Thermo sending unit
- 20 Oil pressure gauge
- 21 Oil pressure gauge unit
- 22 Warning lamp
- 23 Oil bypass alarm switch

- B: Terminal B
- E: Terminal E
- L: Terminal L
- M: Terminal M
- P: Terminal P
- R: Terminal R
- S: Terminal S
- SW: Terminal SW

18459

# STRUCTURE AND OPERATION

## <12V Specification>

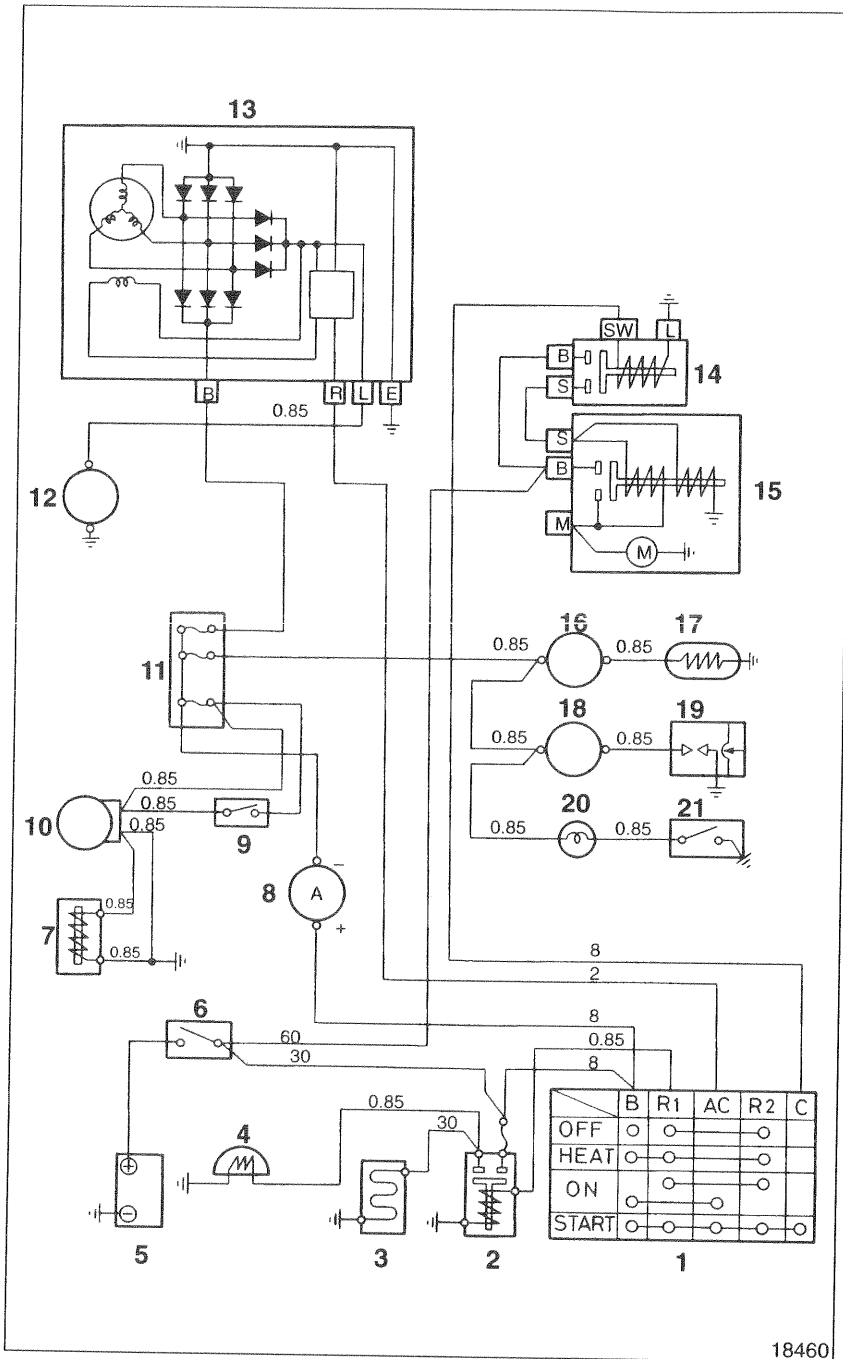

- 1 Starter switch
- 2 Heater relay
- 3 Air heater
- 4 Heater indicator
- 5 Battery
- 6 Battery switch
- 7 Tachometer sensor
- 8 Ammeter
- 9 Lamp switch
- 10 Tachometer
- 11 Fuse box
- 12 Hour meter
- 13 Alternator
- 14 Starter relay
- 15 Starter
- 16 Thermometer (for coolant)
- 17 Thermo sending unit
- 18 Oil pressure gauge
- 19 Oil pressure gauge unit
- 20 Warning lamp
- 21 Oil bypass alarm switch

- B:** Terminal B  
**E:** Terminal E  
**L:** Terminal L  
**M:** Terminal M  
**R:** Terminal R  
**S:** Terminal S  
**SW:** Terminal SW

18460

## 2. Alternator

&lt;24V-35A&gt;

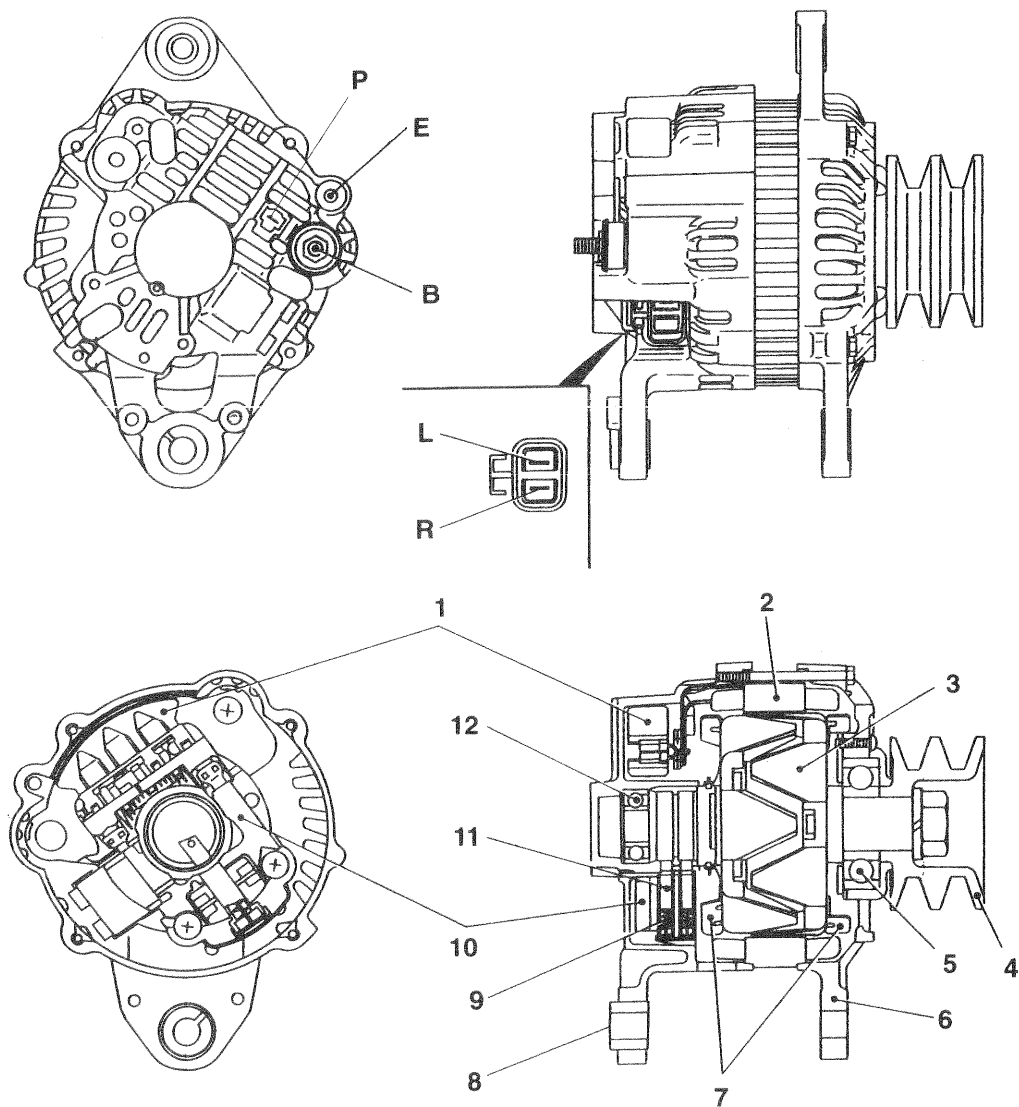

16742

- 1 Rectifier
- 2 Stator assembly
- 3 Rotor assembly
- 4 Pulley
- 5 Front bearing
- 6 Front bracket

- 7 Fan
- 8 Rear bracket
- 9 Brush spring
- 10 Regulator & brush holder
- 11 Brush
- 12 Rear bearing

- B: Terminal B
- E: Terminal E
- L: Terminal L
- P: Terminal P
- R: Terminal R

# STRUCTURE AND OPERATION

<24V-80A (with brush)>

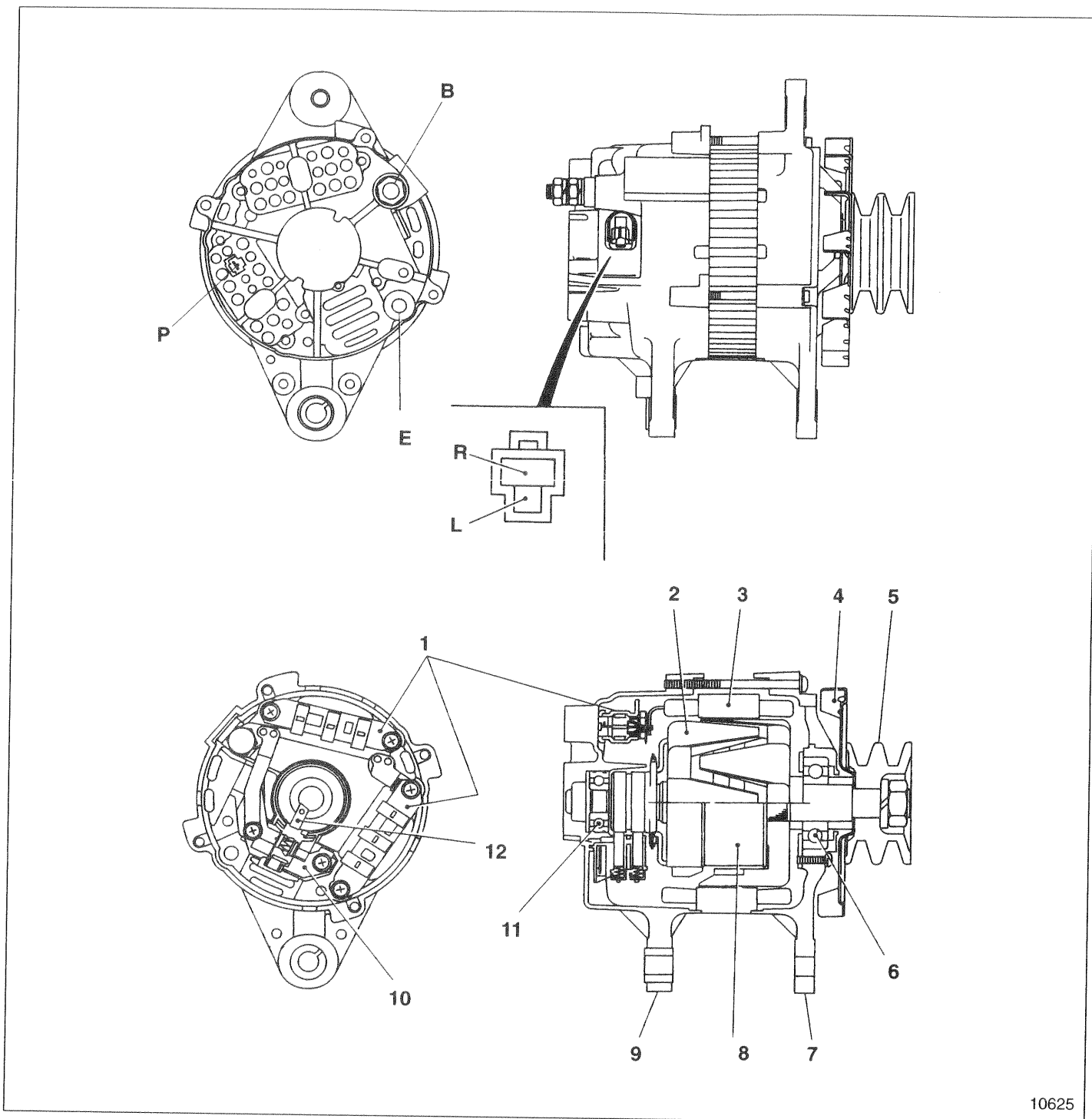

10625

- 1 Rectifier
- 2 Rotor assembly
- 3 Stator assembly
- 4 Fan
- 5 Pulley
- 6 Front bearing

- 7 Front bracket
- 8 Field coil
- 9 Rear bracket
- 10 Regulator
- 11 Rear bearing
- 12 Brush

- B: Terminal B
- E: Terminal E
- L: Terminal L
- P: Terminal P
- R: Terminal R

&lt;12V-60A&gt;

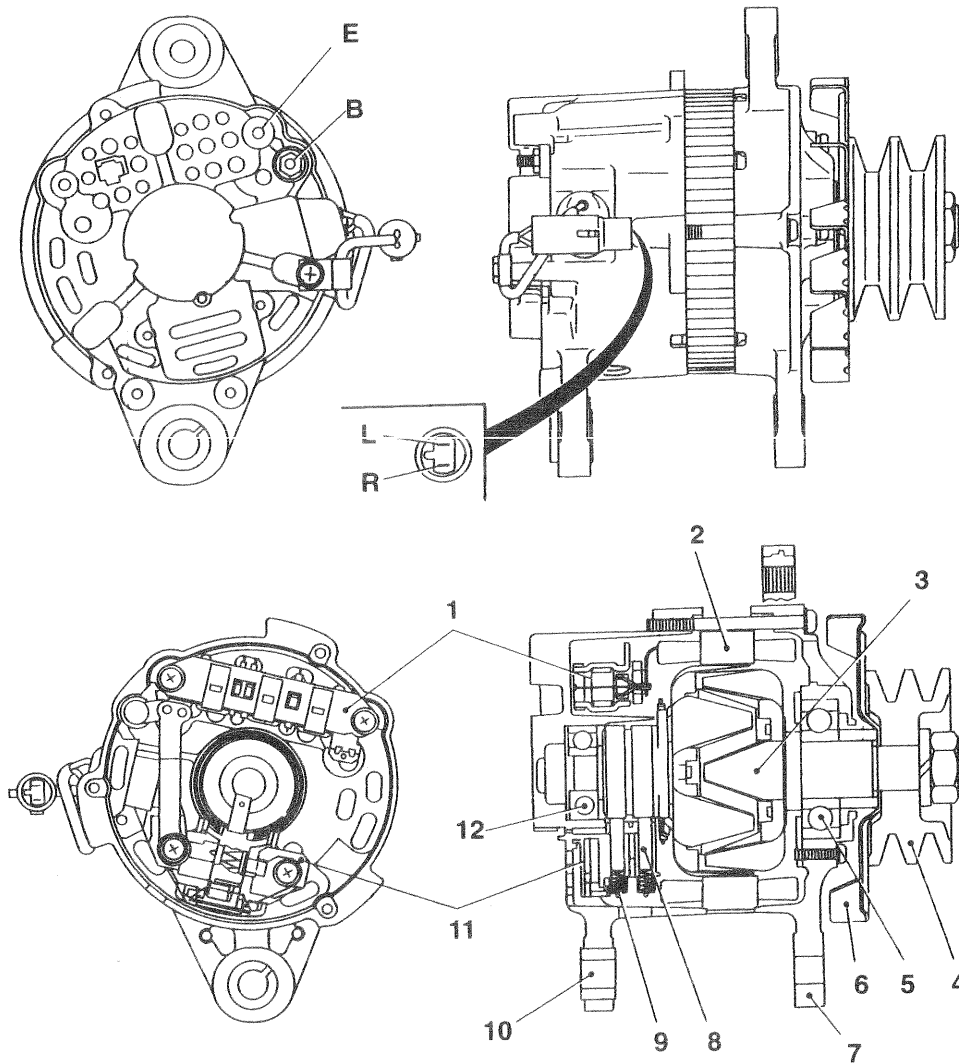

16743

- |                   |                           |                      |
|-------------------|---------------------------|----------------------|
| 1 Rectifier       | 7 Front bracket           | <b>B:</b> Terminal B |
| 2 Stator assembly | 8 Brush                   | <b>E:</b> Terminal E |
| 3 Rotor assembly  | 9 Brush spring            | <b>L:</b> Terminal L |
| 4 Pulley          | 10 Rear bracket           | <b>R:</b> Terminal R |
| 5 Front bearing   | 11 Regular & brush holder |                      |
| 6 Fan             | 12 Rear bearing           |                      |

# STRUCTURE AND OPERATION

<24V-40A (with vacuum pump)>

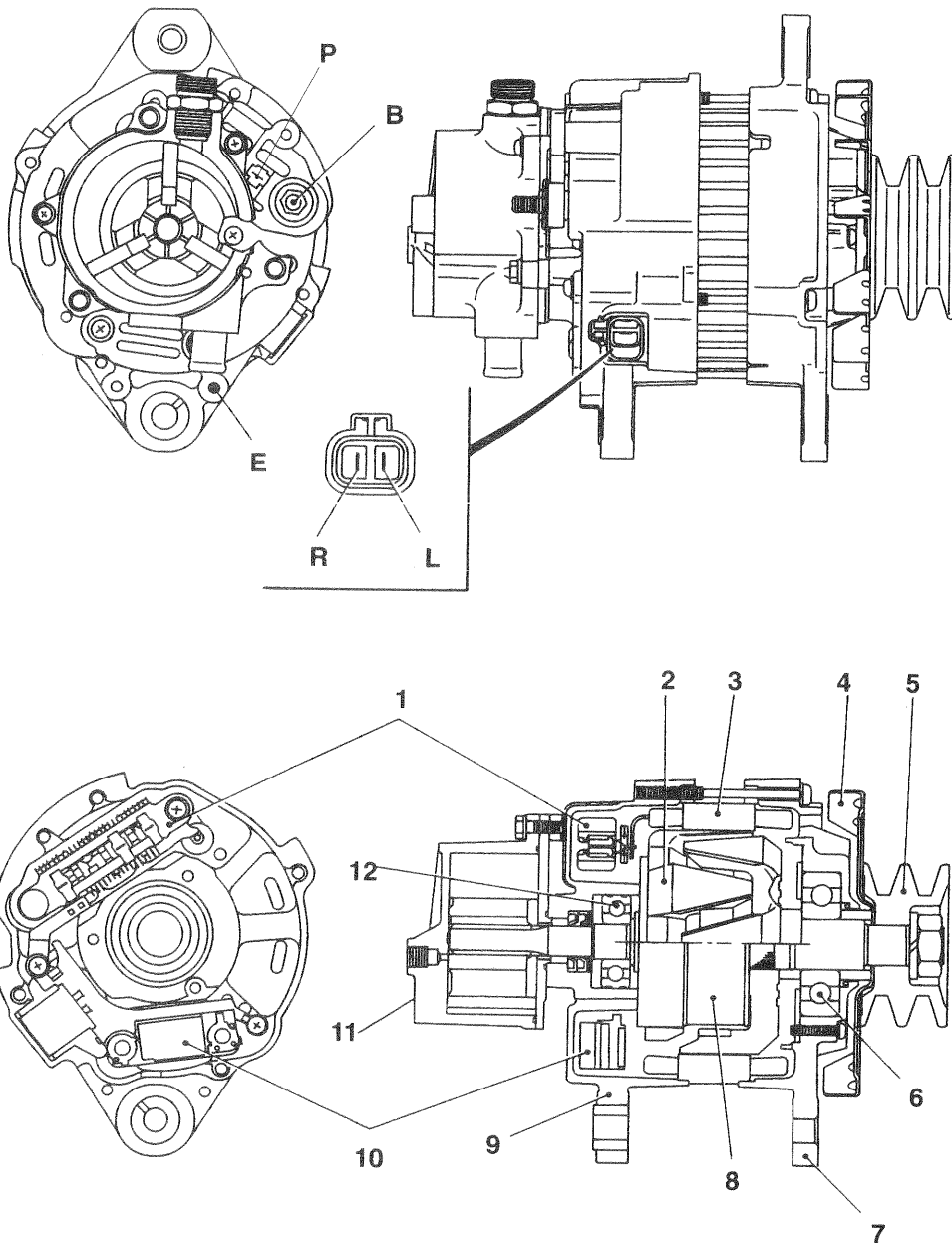

09431

- 1 Rectifier
- 2 Rotor assembly
- 3 Stator assembly
- 4 Fan
- 5 Pulley
- 6 Front bearing

- 7 Front bracket
- 8 Field coil
- 9 Rear bracket
- 10 Regulator
- 11 Vacuum pump
- 12 Rear bearing

- B: Terminal B
- E: Terminal E
- L: Terminal L
- P: Terminal P
- R: Terminal R

## &lt;24V-40A (without vacuum pump), 12V-80A&gt;

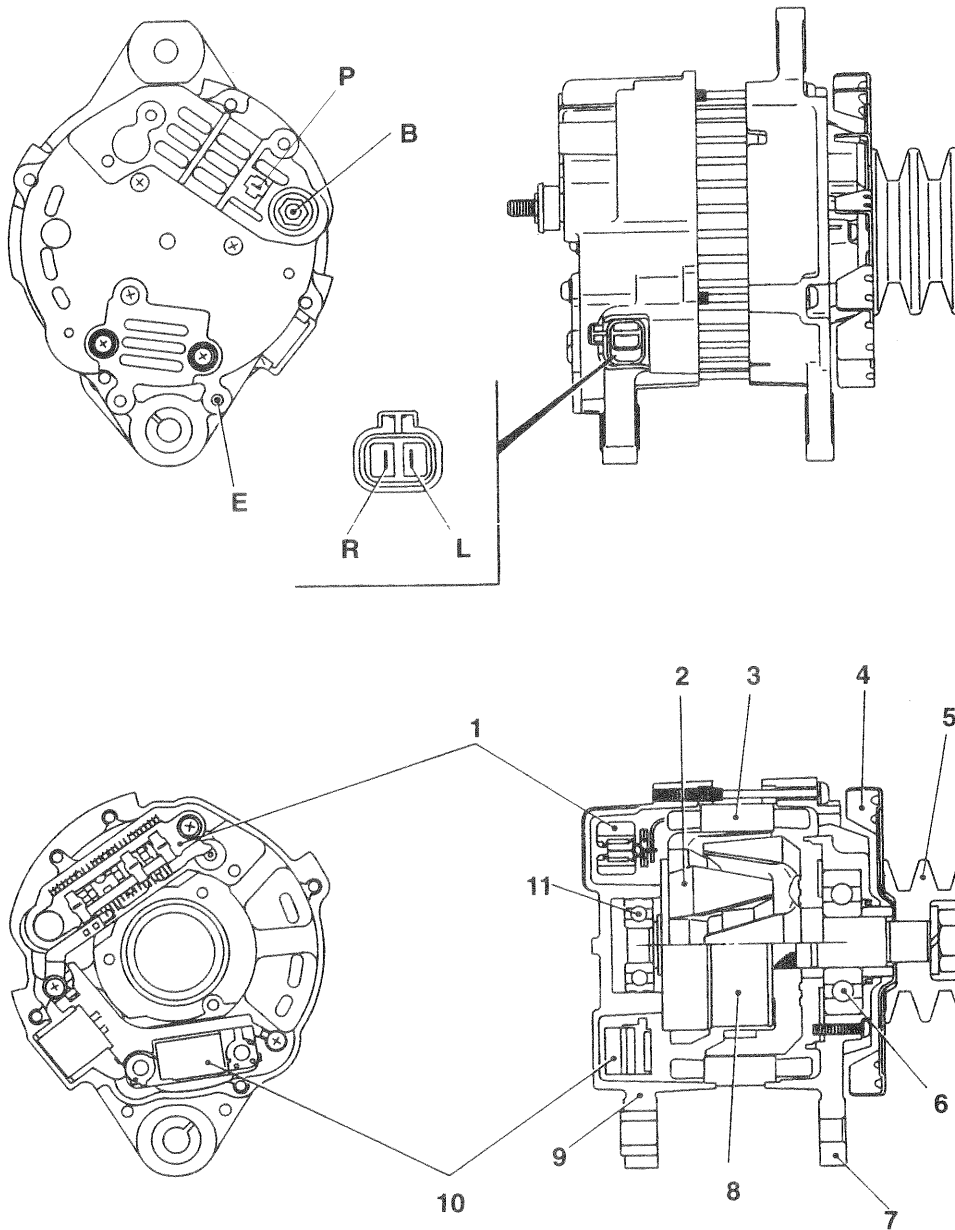

08644

- 1 Rectifier
- 2 Rotor assembly
- 3 Stator assembly
- 4 Fan
- 5 Pulley
- 6 Front bearing

- 7 Front bracket
- 8 Field coil
- 9 Rear bracket
- 10 Regulator
- 11 Rear bearing

- B: Terminal B
- E: Terminal E
- L: Terminal L
- P: Terminal P
- R: Terminal R

# STRUCTURE AND OPERATION

<24V-50A>

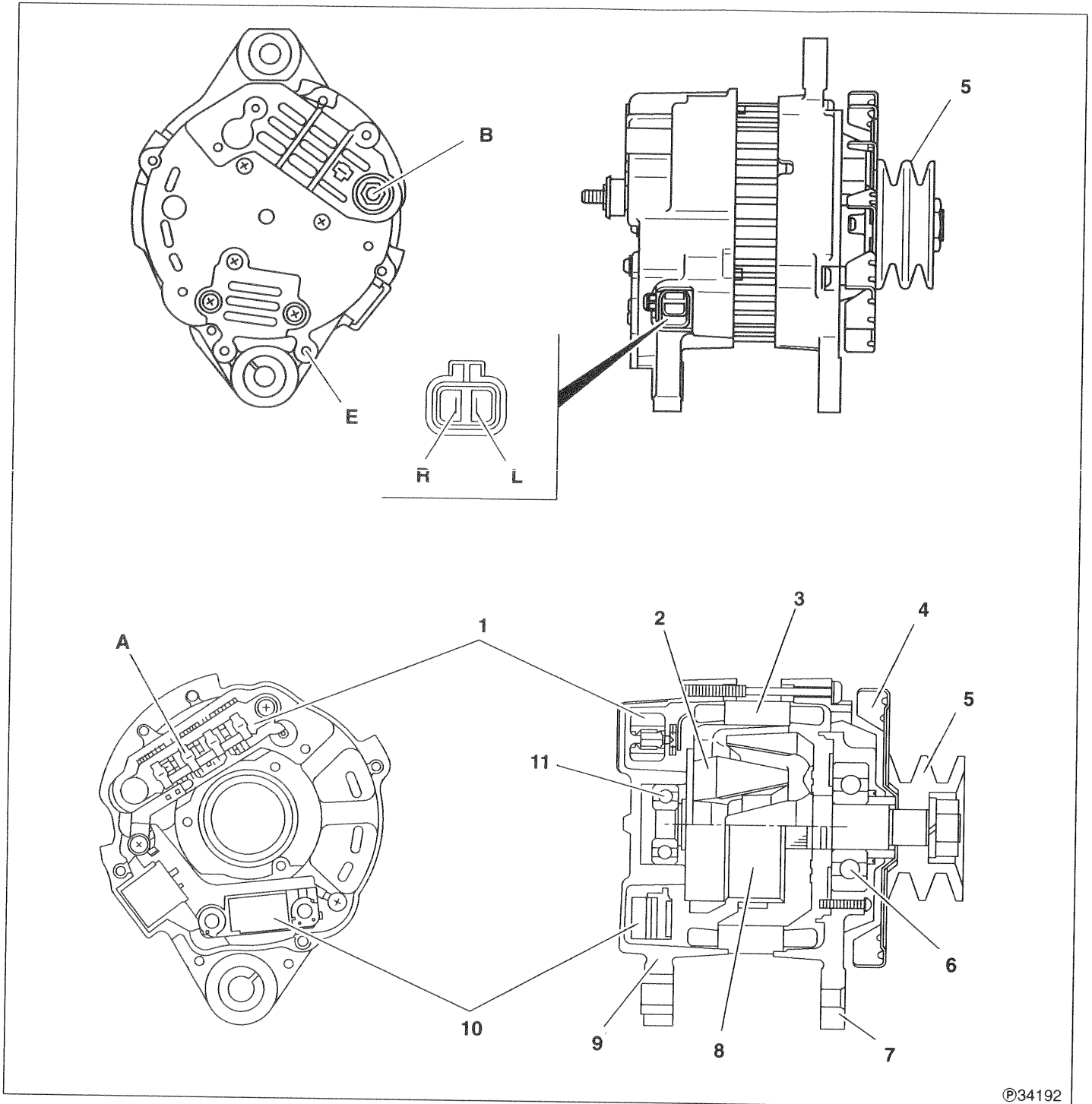

©34192

- 1 Rectifier
- 2 Rotor assembly
- 3 Stator assembly
- 4 Fan
- 5 Pulley
- 6 Front bearing

- 7 Front bracket
- 8 Field coil
- 9 Rear bracket
- 10 Regulator
- 11 Rear bearing

- A: Neutral point diode
- B: Terminal B
- E: Terminal E
- L: Terminal L
- R: Terminal R

<24V-80A (brushless), 90A>

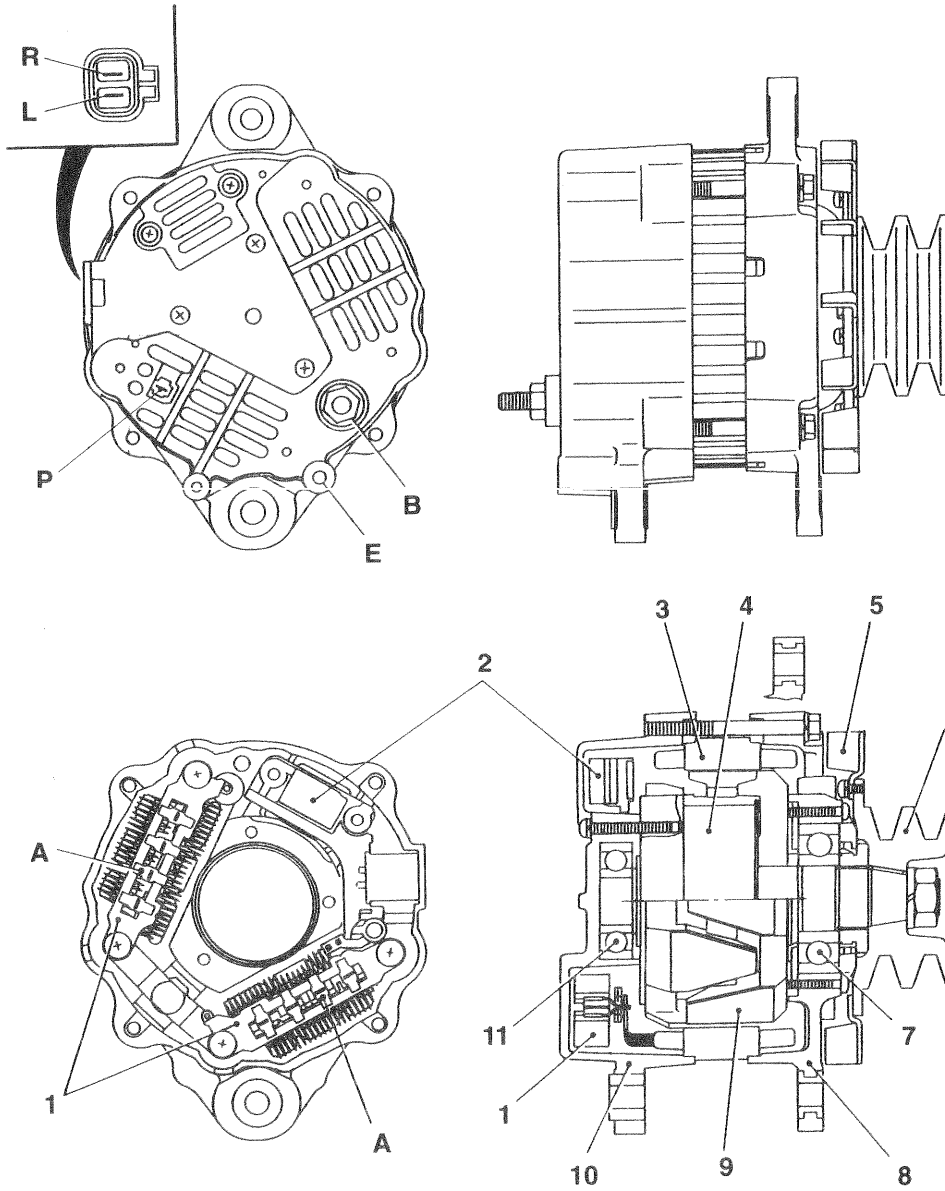

16744

- 1 Rectifier
- 2 Regulator
- 3 Stator assembly
- 4 Field coil
- 5 Fan
- 6 Pulley

- 7 Front bearing
- 8 Front bracket
- 9 Rotor assembly
- 10 Rear bracket
- 11 Rear bearing

- A: Neutral point diode <90A>
- B: Terminal B
- E: Terminal E
- L: Terminal L
- P: Terminal P
- R: Terminal R

# STRUCTURE AND OPERATION

## ● Alternator with neutral point diode

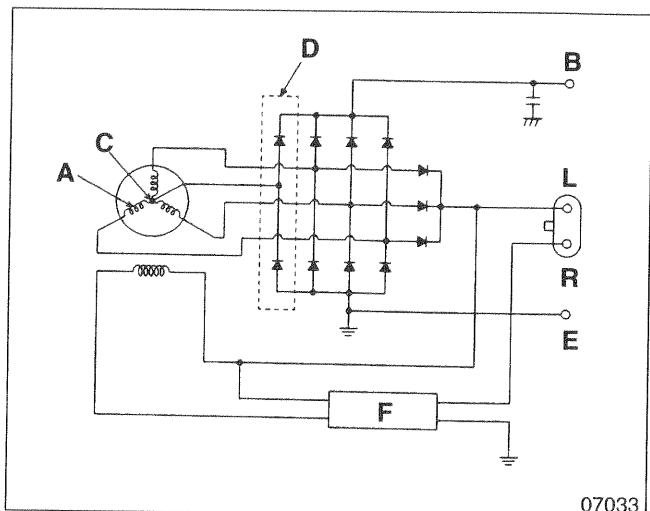

### Effectiveness of alternator with neutral point diode

The point where three stator coils **A** are coupled is called the neutral point **C**. Addition of two diodes **D** to the current alternator which uses six diodes makes it possible to provide a higher DC output than an alternator without neutral point diodes.

- B**: Alternator terminal B
- E**: Alternator terminal E
- F**: IC regulator
- L**: Alternator terminal L
- R**: Alternator terminal R

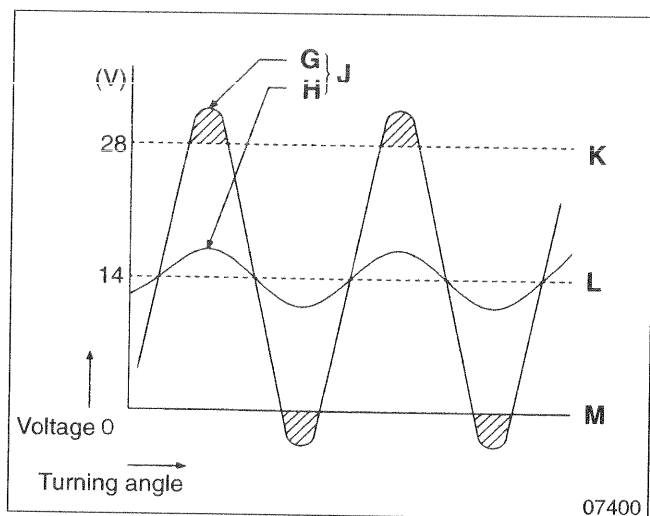

### Variations in potential at neutral point, and operation of neutral point diode

- The potential at the neutral point **C** varies up and down as shown with the neutral point DC voltage (one half of the output voltage) as the center. When the alternator rotates at a very high speed, the peak values of the potential by far exceed the output voltage. (28V or more, 0V or less)

- G**: During high speed rotation
- H**: During low speed rotation
- J**: Neutral point voltage waveform
- K**: Output voltage
- L**: Mean voltage at neutral point
- M**: Ground potential

In each of the voltage and potential conditions, the neutral point diode operates as described below.

- When the neutral point voltage is more than 0V and less than 28V, the six conventional diodes operate.

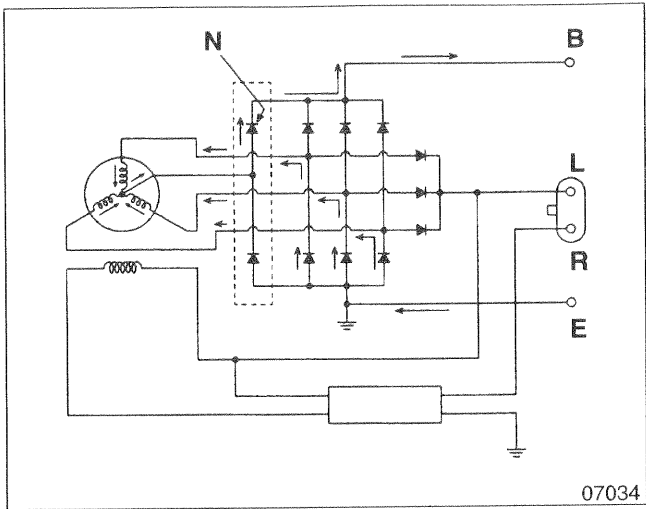

● **When the neutral point voltage is more than 28V**  
The positive side diode **N** conducts to add to the conventional DC output, so a higher DC voltage is output to each equipment.

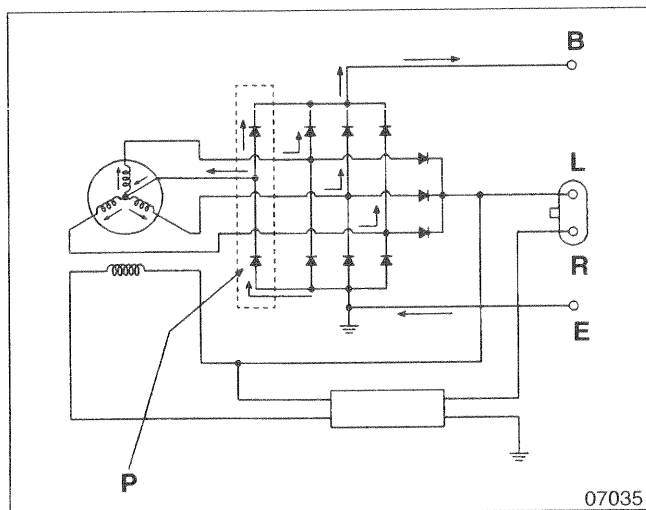

● **When the neutral point voltage is less than 0V**  
The negative side diode **P** conducts, and the neutral point output is supplied via the three conventional diodes.

# STRUCTURE AND OPERATION

## 3. Charging Circuit

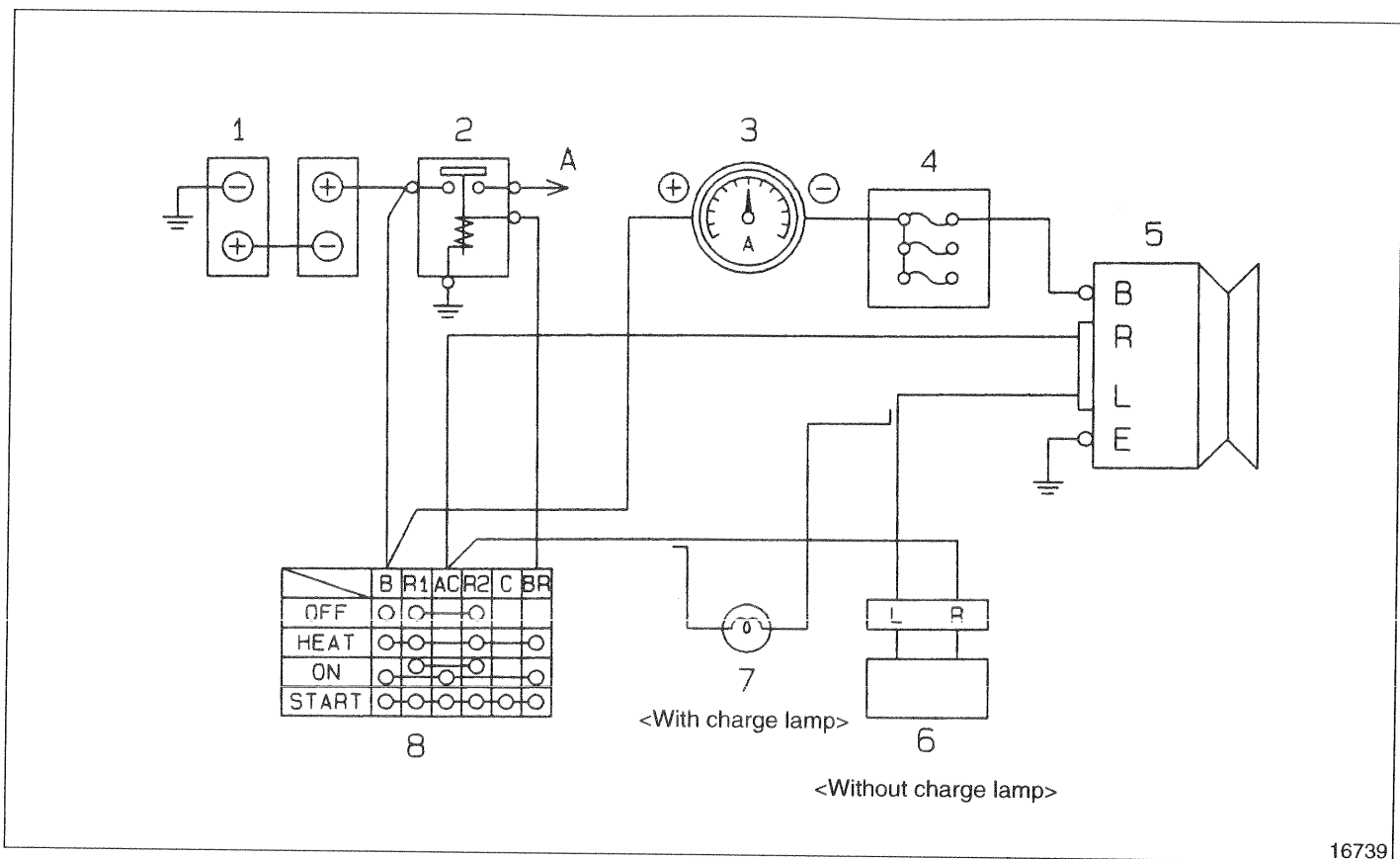

16739

- 1 Battery
- 2 Battery relay
- 3 Ammeter
- 4 Fuse box
- 5 Alternator
- 6 Safety relay <Circuit without charge lamp>
- 7 Charge lamp <Circuit with charge lamp>
- 8 Starter switch

- A: To starter relay terminal B
- B: Terminal B
- E: Terminal E
- L: Terminal L
- R: Terminal R

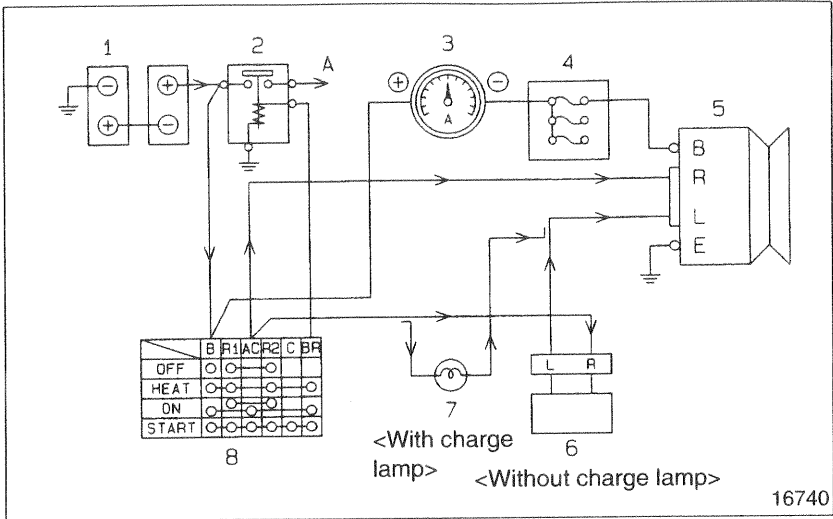

**When engine is stationary**

Position of starter switch 8: ON

- To improve the performance of the alternator 5 in starting power generation at a low speed immediately after the engine has been started, current is set flowing to terminal R.

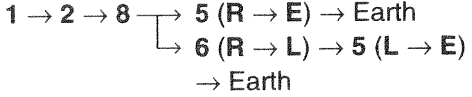

- In the circuit with A charge lamp 7, current flows as shown below.

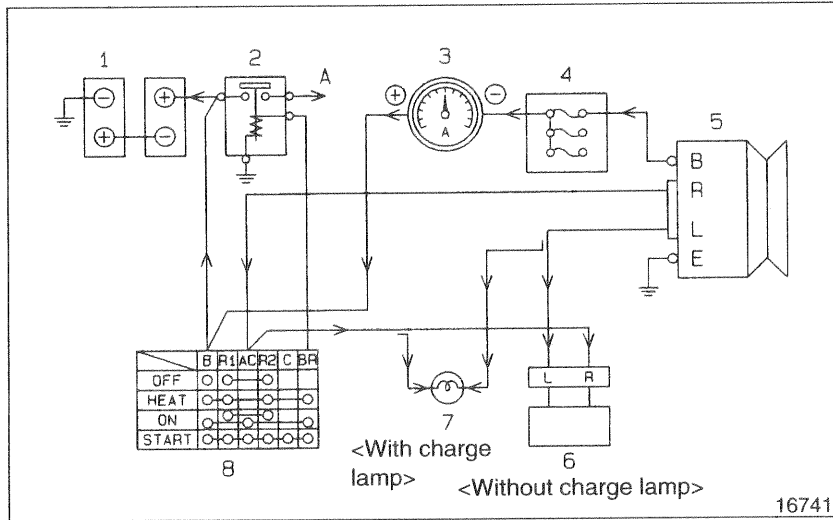
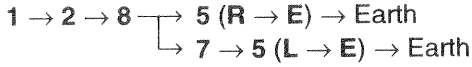

**After engine has been started**

Position of starter switch 8: ON

- The alternator 5 starts generating power.
- The output voltage at terminal B of the alternator 5 becomes higher than the voltage of the battery 1.
- The alternator 5 starts charging the battery 1.



- In the case of the circuit with the charge lamp 7, the charge lamp goes out, as there is no potential difference between the voltage at terminal L of the alternator 5 and the battery voltage.

# STRUCTURE AND OPERATION

## 4. Starter

<24V-6kW>

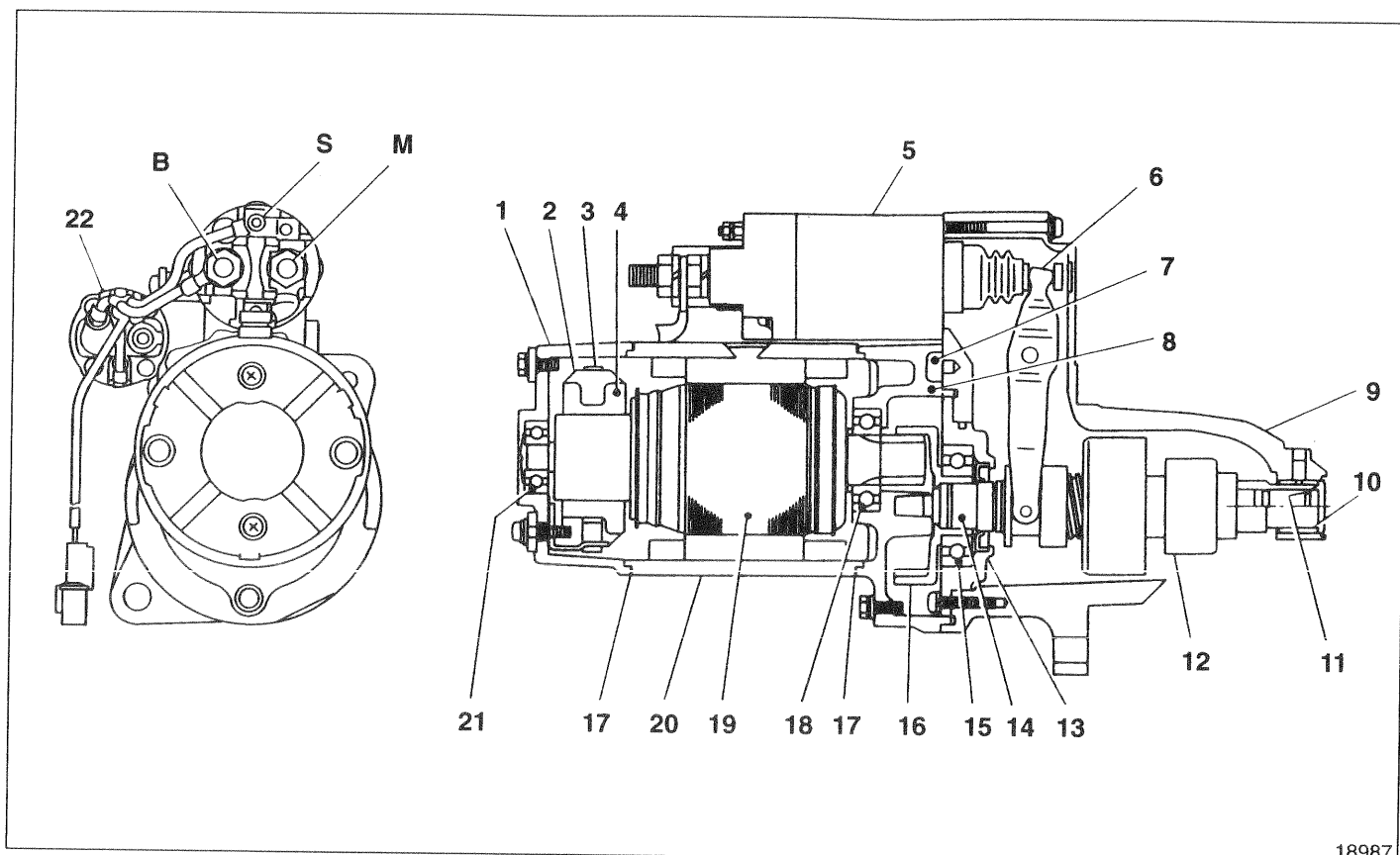

18987

- |                         |                      |
|-------------------------|----------------------|
| 1 Rear bracket          | 14 Gearshaft         |
| 2 Brush                 | 15 Gearshaft bearing |
| 3 Brush spring          | 16 Internal gear     |
| 4 Brush holder assembly | 17 Rubber packing    |
| 5 Magnet switch         | 18 Front bearing     |
| 6 Lever                 | 19 Armature          |
| 7 Guide                 | 20 Yoke assembly     |
| 8 Center bracket        | 21 Rear bearing      |
| 9 Front bracket         | 22 Starter relay     |
| 10 Sleeve bearing       |                      |
| 11 Stopper ring         |                      |
| 12 Overrunning clutch   |                      |
| 13 Gear bracket         |                      |
- B:** Terminal B  
**M:** Terminal M  
**S:** Terminal S

<24V-5kW>

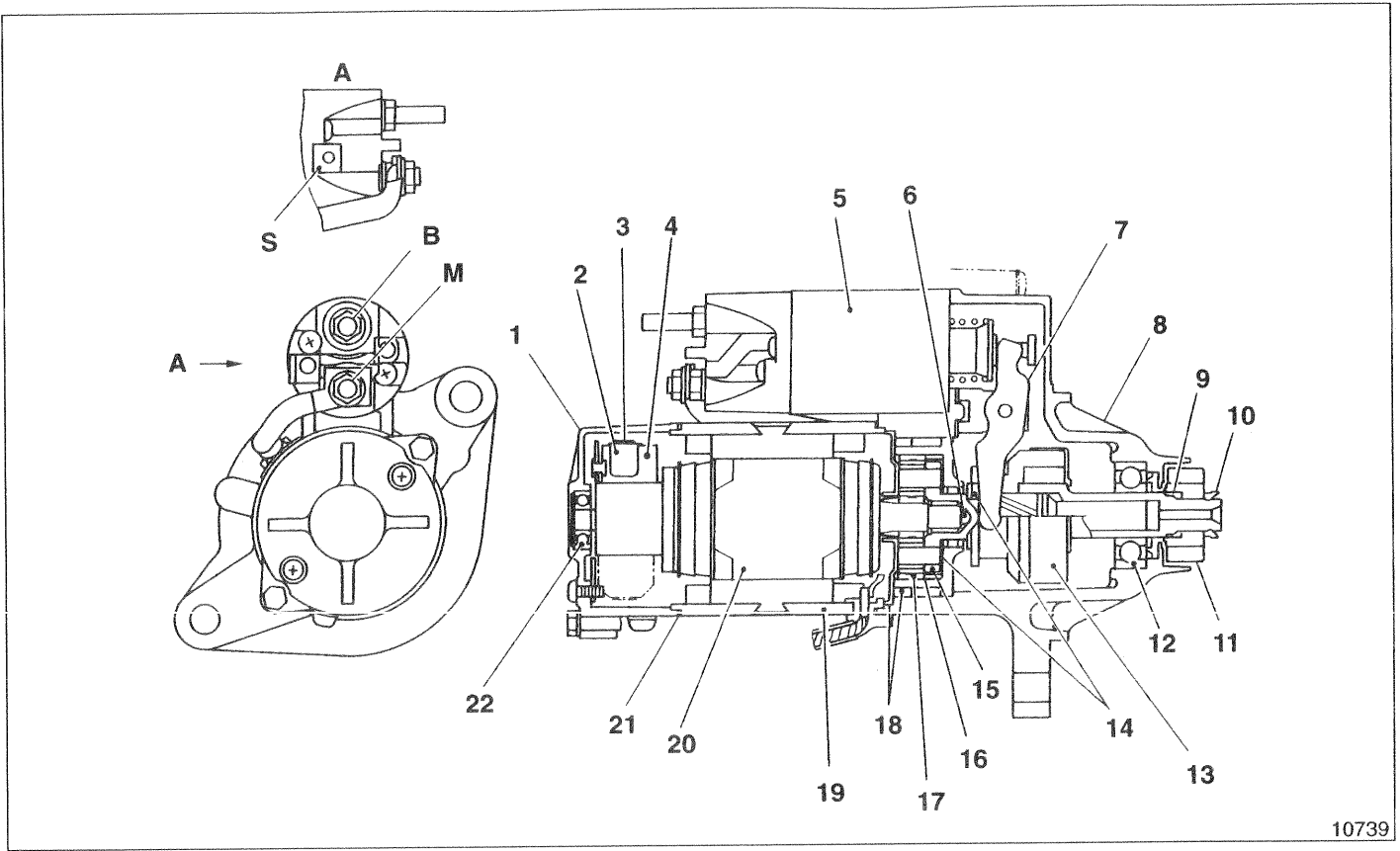

10739

- |                         |                           |                      |
|-------------------------|---------------------------|----------------------|
| 1 Rear bracket          | 10 Pinion stopper         | 19 Yoke assembly     |
| 2 Brush                 | 11 Pinion                 | 20 Armature assembly |
| 3 Brush spring          | 12 Front bearing          | 21 Packing           |
| 4 Brush holder assembly | 13 Overrunning clutch     | 22 Rear bearing      |
| 5 Magnet switch         | 14 Washer                 |                      |
| 6 Ball                  | 15 Gearshaft assembly     | B: Terminal B        |
| 7 Lever                 | 16 Internal gear assembly | M: Terminal M        |
| 8 Front bracket         | 17 Planetary gear         | S: Terminal S        |
| 9 Spring                | 18 Packing                |                      |

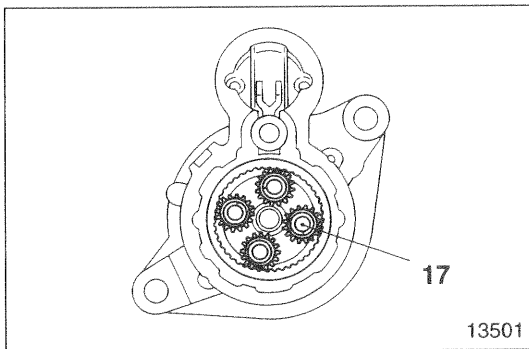

13501

This starter uses planetary gear 17 in the reduction gear mechanism.

# STRUCTURE AND OPERATION

<12V-5kW>

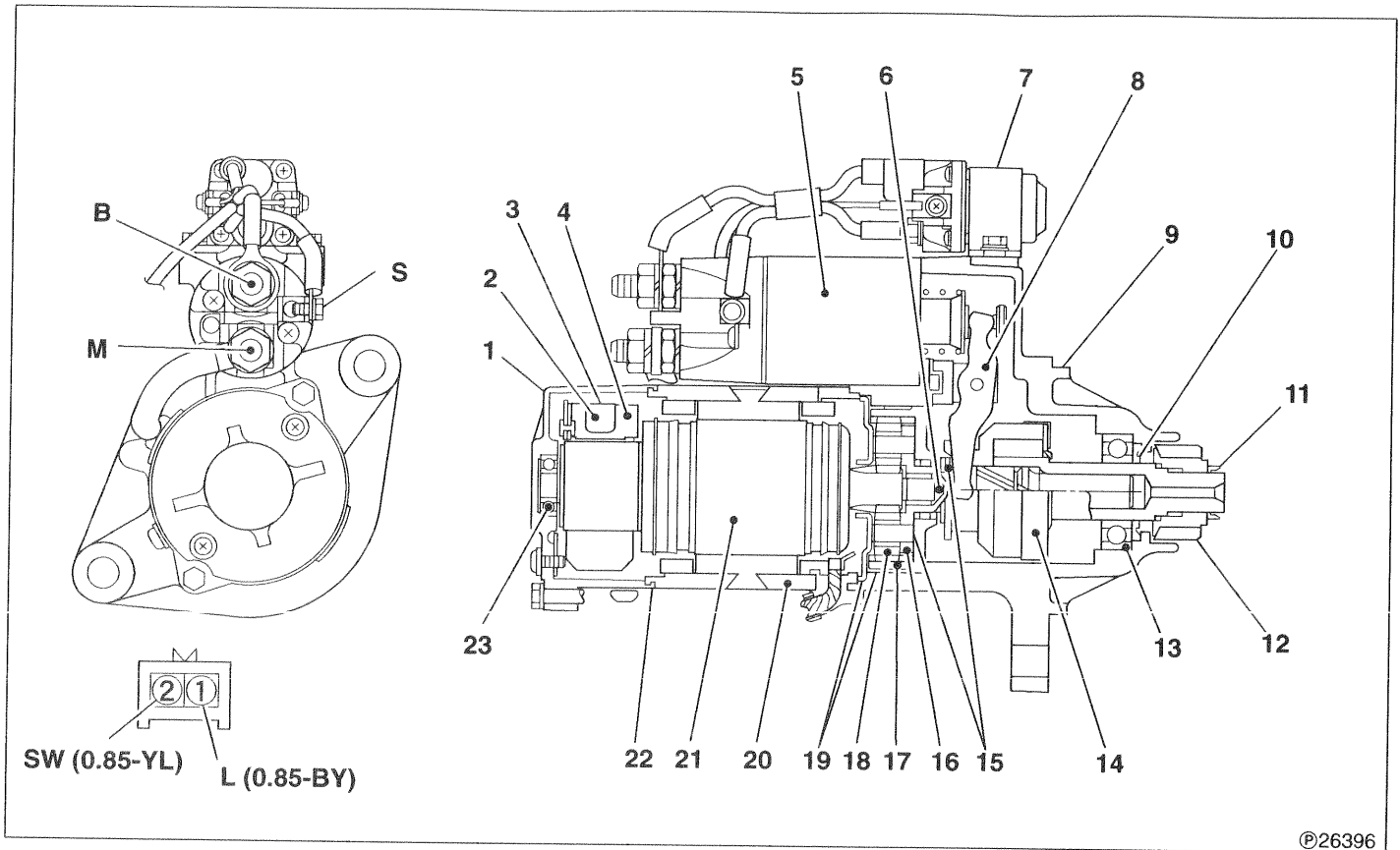

- |                   |                            |                      |
|-------------------|----------------------------|----------------------|
| 1 Rear bracket    | 11 Pinion stopper          | 21 Armature assembly |
| 2 Brush           | 12 Pinion                  | 22 Rubber packing    |
| 3 Brush spring    | 13 Front bearing           | 23 Rear bearing      |
| 4 Brush holder    | 14 Overrunning clutch      |                      |
| 5 Magnetic switch | 15 Washer                  |                      |
| 6 Ball            | 16 Gear shaft              | B: Terminal B        |
| 7 Starter relay   | 17 Internal gear assembly  | L: Terminal L        |
| 8 Lever           | 18 Planetary gear assembly | M: Terminal M        |
| 9 Front bracket   | 19 Rubber packing          | S: Terminal S        |
| 10 Spring         | 20 Yoke assembly           | SW: Terminal SW      |

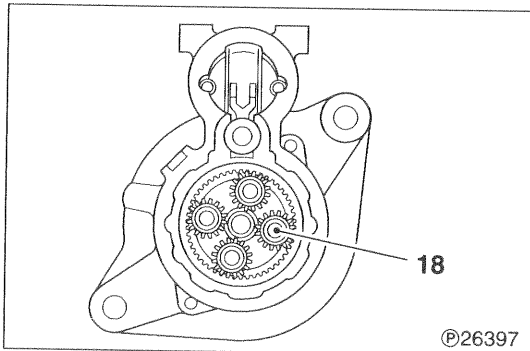

This starter uses planetary gear **18** for the reduction gear system.

### 5. Preheating Circuit

<Intake Air Heater>

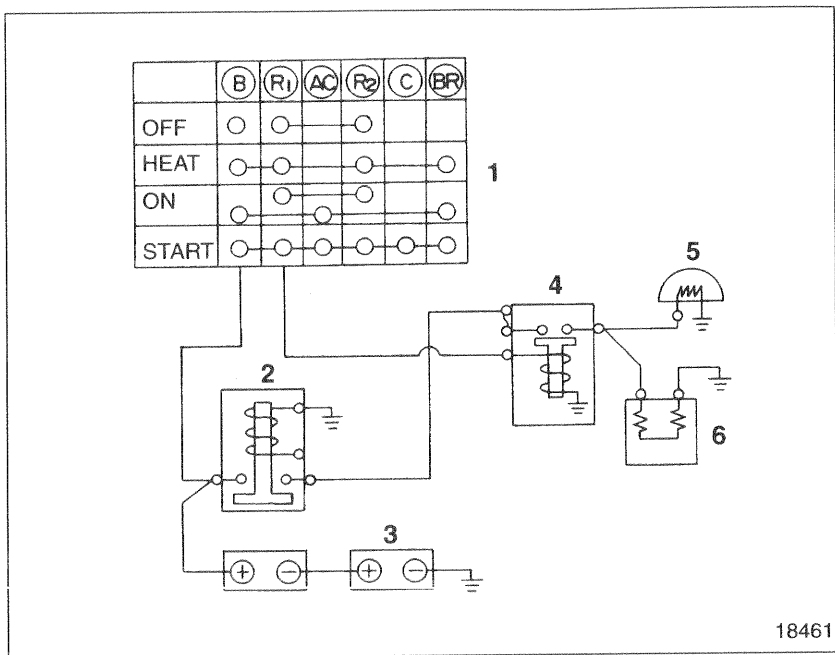

- 1 Starter switch
- 2 Battery relay
- 3 Battery
- 4 Heater relay
- 5 Heater indicator
- 6 Intake air heater

<Glow Plug>

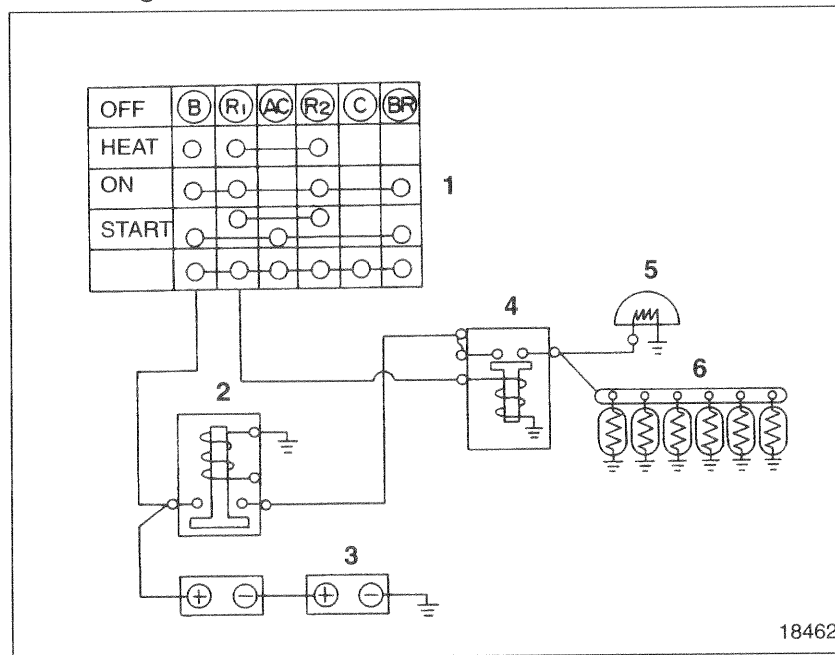

- 1 Starter switch
- 2 Battery relay
- 3 Battery
- 4 Heater relay
- 5 Glow indicator
- 6 Glow plug

# STRUCTURE AND OPERATION

## 6. Engine Starter Circuit

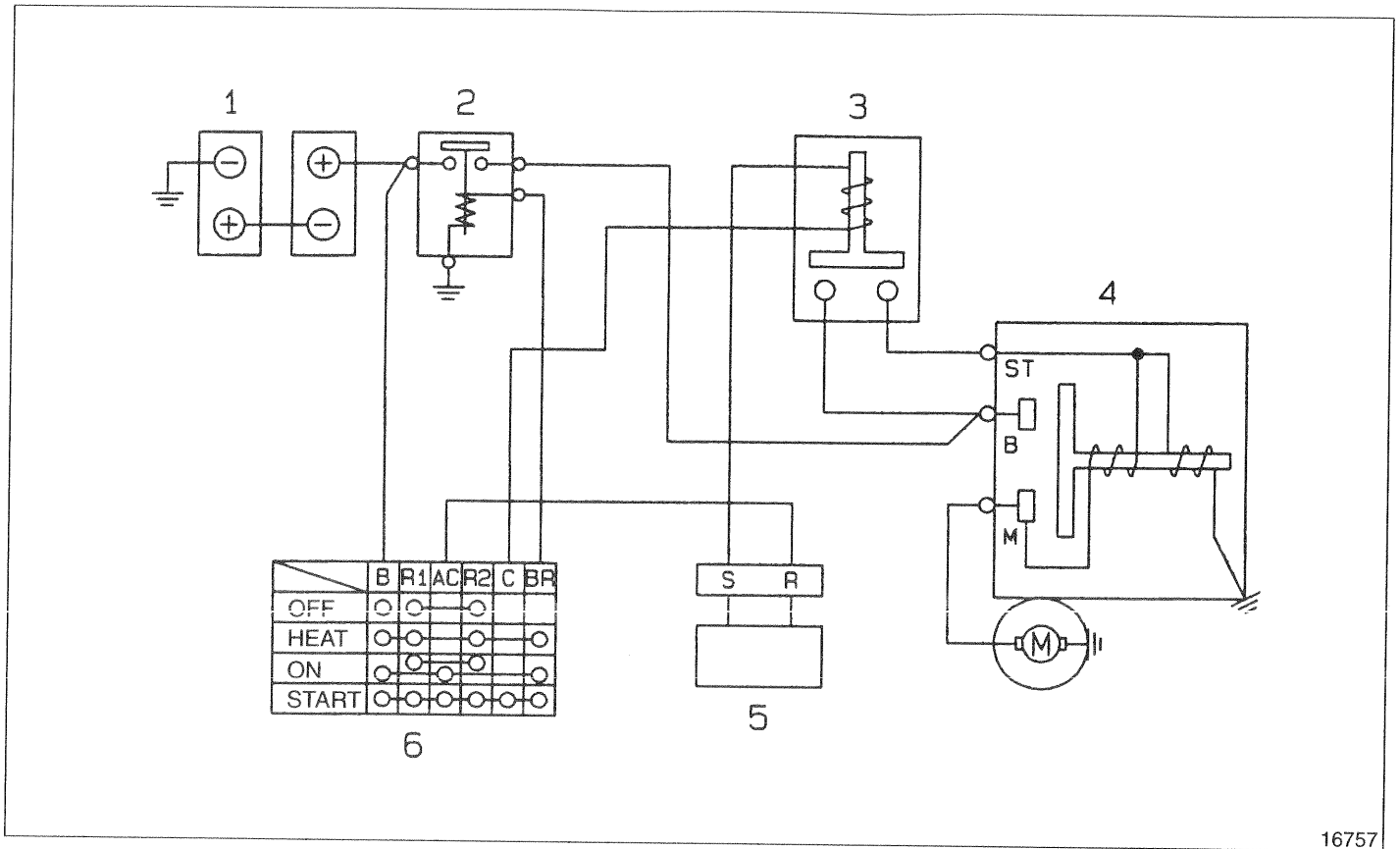

16757

- 1 Battery
- 2 Battery relay
- 3 Starter relay
- 4 Starter
- 5 Safety relay
- 6 Starter switch

## 7. Safety Relay

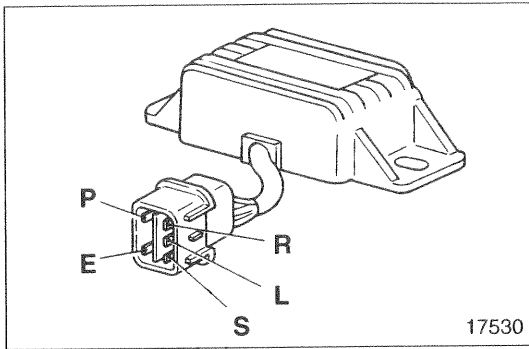

The safety relay detects the rotating speed of the alternator. When the rotating speed exceeds the reference value, the safety relay keeps the starter inoperative even if the starter switch is accidentally set to ON while the engine is running.

P: Terminal P  
R: Terminal R  
L: Terminal L  
S: Terminal S  
E: Terminal E

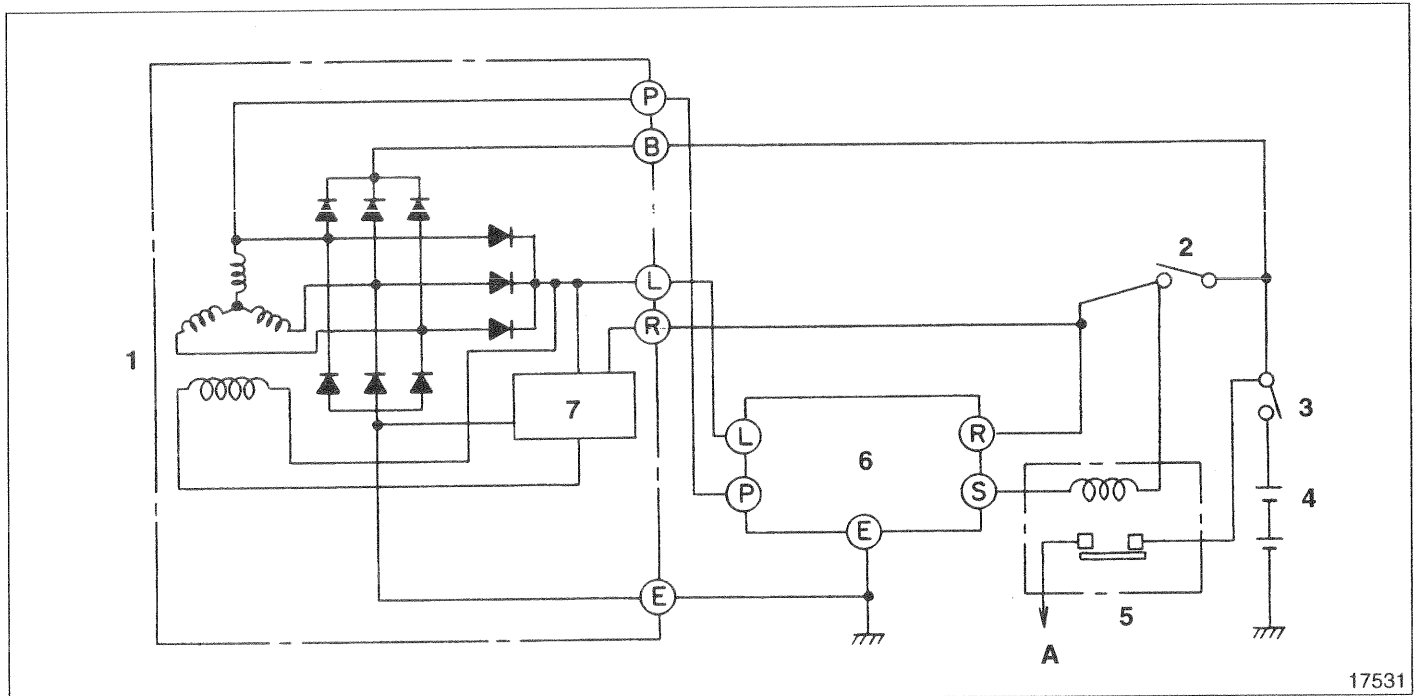

1 Alternator  
2 Starter switch  
3 Battery switch  
4 Battery  
5 Starter relay

6 Safety relay  
7 IC regulator

A: To starter terminal B

- When the starter switch 2 is set to ON, current flows from the starter relay 5 through terminal S of the safety relay 6 to terminal E, and contact P<sub>1</sub> closes.
- When rotation of the starter causes the engine to start running, pulses with a frequency of a tenth of the alternator speed are generated at terminal P of the alternator 1.
- When the pulse frequency at terminal P of the alternator 1 exceeds the reference value, the continuity between terminals S and E is lost, and the starter remains inoperative even if the starter switch 2 is set to ON while the engine is running.

# STRUCTURE AND OPERATION

## 8. Automatic Stop System

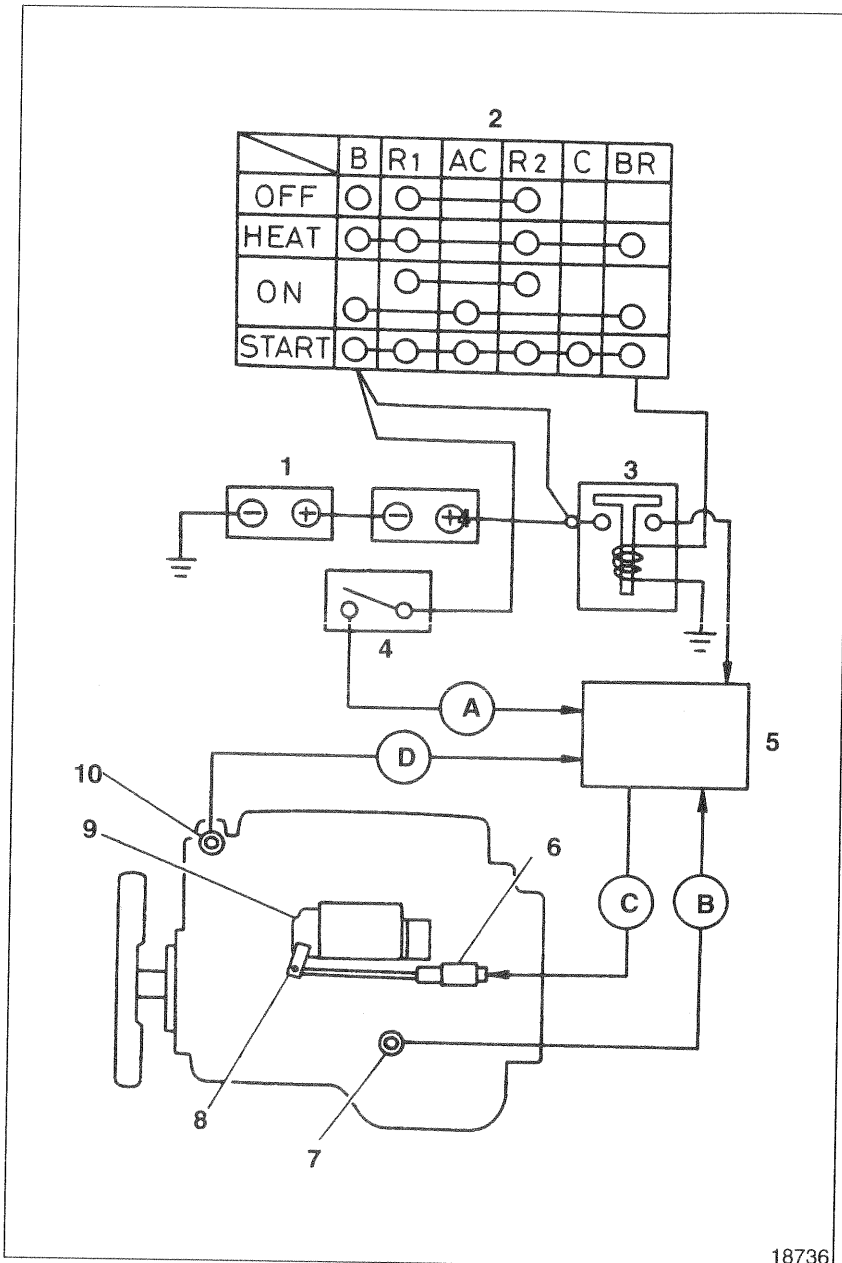

- 1 Battery
  - 2 Starter switch
  - 3 Battery relay
  - 4 Stop switch
  - 5 Solenoid relay
  - 6 Solenoid
  - 7 Engine oil pressure switch
  - 8 Stop lever
  - 9 Injection pump governor
  - 10 Water temperature sensor
- Ⓐ: Engine stop signal
  - Ⓑ: Hydraulic pressure detection signal
  - Ⓒ: Solenoid drive signal
  - Ⓓ: Coolant temperature detection signal

When the oil pressure becomes abnormal or when the coolant temperature abnormally rises while the engine is running, the automatic stop system automatically stops the engine.

When anything wrong occurs in the oil pressure or coolant temperature, it is detected by the engine oil pressure switch 7 or water temperature sensor 10 which operates the solenoid relay 5. As a result, the solenoid 6 moves the stop lever 8 of the injection pump governor 9 in the direction A that the engine stops, thereby stopping the engine.

The system comes in two types; the shutdown type and run-on type.

<Shutdown>

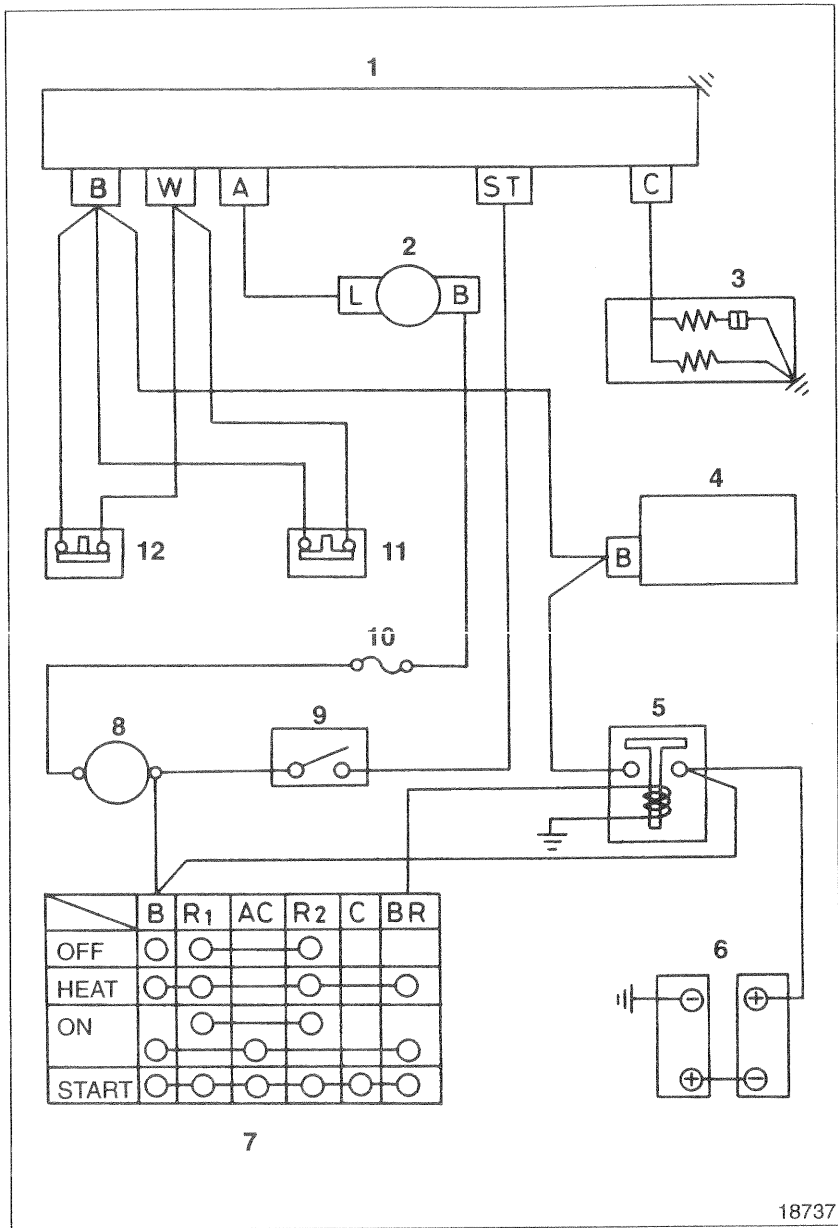

- 1 Solenoid relay
- 2 Alternator
- 3 Solenoid
- 4 Starter
- 5 Battery relay
- 6 Battery
- 7 Starter switch
- 8 Ammeter
- 9 Stop switch
- 10 Fuse box
- 11 Engine oil pressure switch
- 12 Coolant temperature sensor

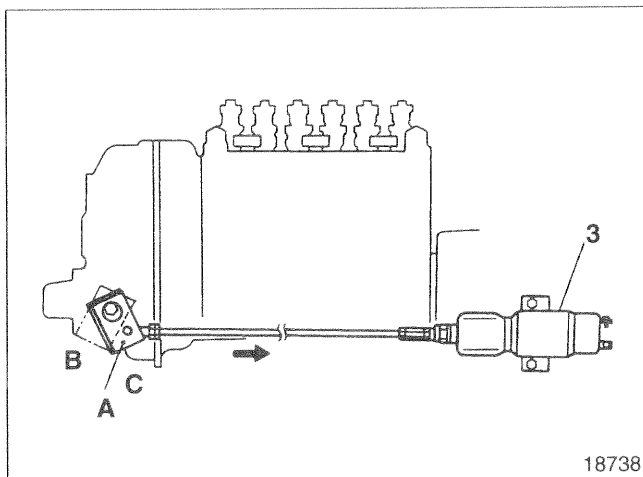

- On normal condition, solenoid 3 is not energized and the stop lever A of the injector pump governor is at the drive side B to keep the engine in running condition.
- When a trouble occurs, solenoid 3 is energized and pulls the stop lever A to the stop side C to stop the engine.

# STRUCTURE AND OPERATION

## Before engine starts

- Position of starter switch 7: ON

6 → 5 → 7 (B → BR) → 5 (coil) → Earth  
 4 (B) → 1 (B) → 11 → 1 (W) → Earth

- Since no generated voltage from the alternator 2 is available at terminal A of the solenoid relay 1, the solenoid relay 1 remains inoperative, and no current is supplied to the solenoid 3. Therefore, the stop lever A of the injection pump governor stays at the position C where the engine can be started.

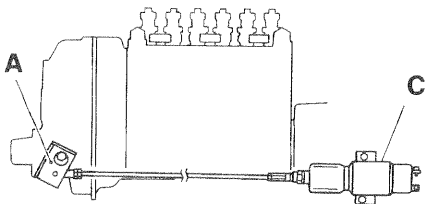
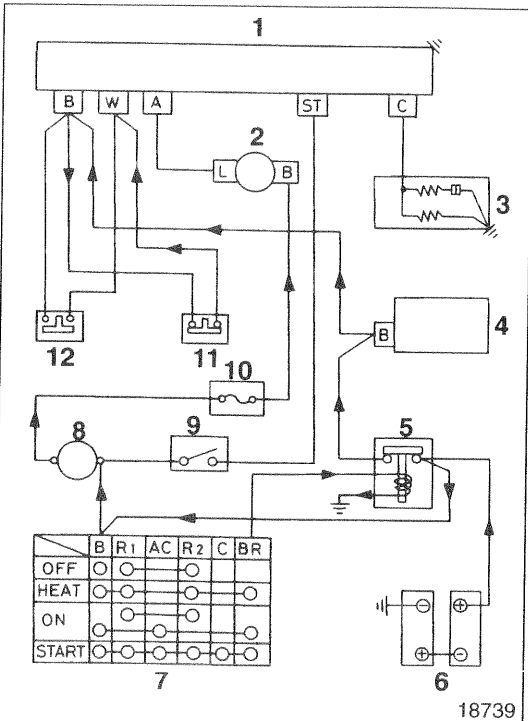

## When engine starts

- Position of starter switch 7: START

When the engine is started, the generated voltage from the alternator 2 is applied to terminal A of the solenoid relay 1. At this point, the oil pressure is still low. Therefore, the contact of the oil pressure switch 11 remains closed, and current flows to terminal W of the solenoid relay 1 to actuate the solenoid relay. In the solenoid relay, however, the voltage applied to terminal A is accumulated in the capacitor, so the current does not immediately flow to the operating circuit in the relay, thereby delaying the time the solenoid relay is actuated.

During the period, the engine oil pressure rises, and the contact of the oil pressure switch opens to stop the supply of current to terminal W of the solenoid relay, making the solenoid relay completely inactive.

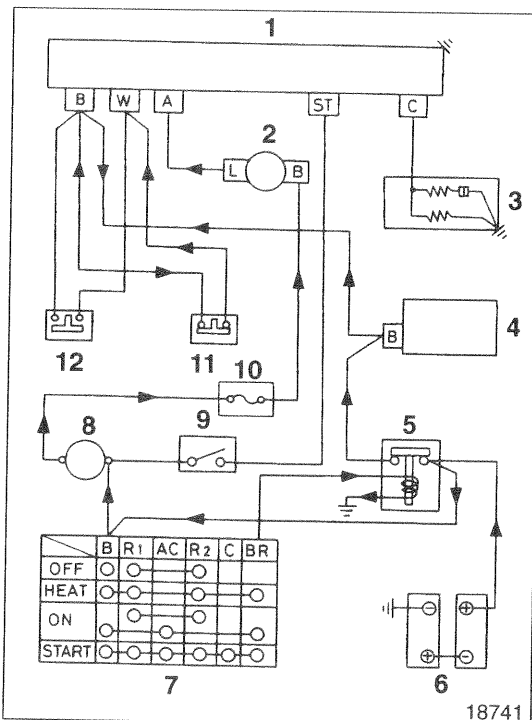

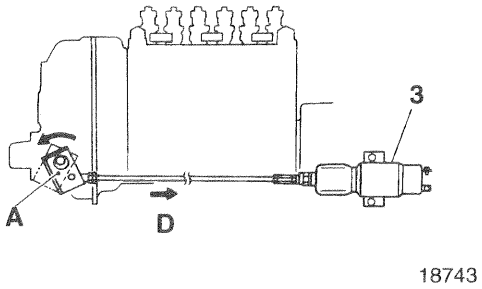
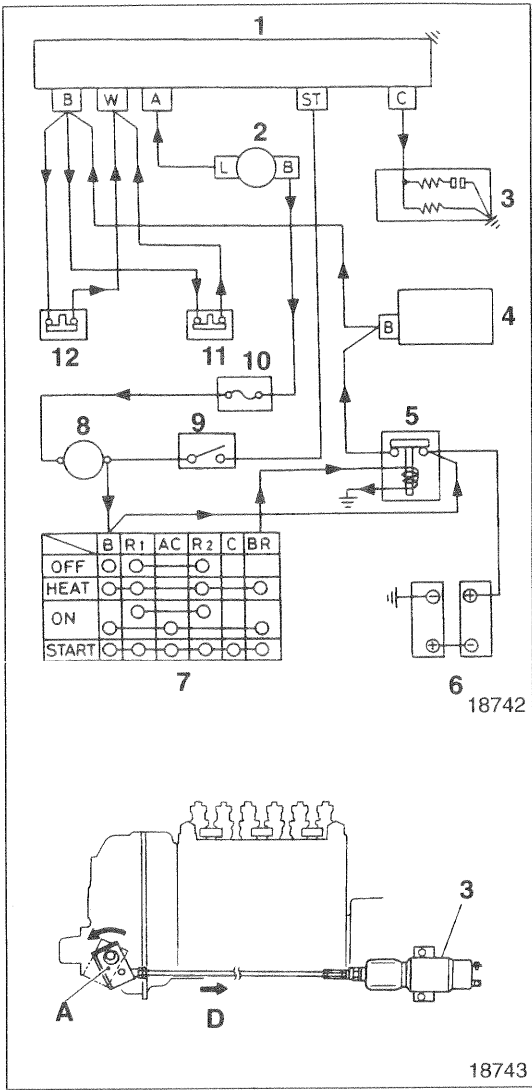

**When engine is automatically stopped**

- When the oil pressure abnormally falls or the coolant temperature abnormally rises while the engine is running, engine oil pressure switch 11 or coolant temperature sensor (thermo switch) 12 turns on and current flows as described below.

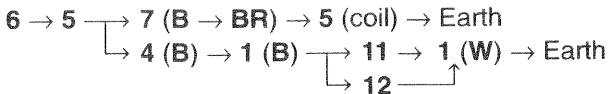

- At this point, the current from terminal A of the solenoid relay 1 is flowing the internal circuit, the switch in the relay is activated and the current flows as follows:



- As a result, solenoid 3 is activated and pulls the stop lever A in direction D to stop the engine.
- Even after losing the generating voltage from the alternator 2, the internal capacitor of the solenoid relay 1 keeps the solenoid 3 in position.

**When engine is manually stopped**

- Position of stop switch 9: ON

Irrespective of the generating voltage of the alternator 2, current from stop switch 9 flows to the internal circuit via ST-terminal of the solenoid relay 1 to activate the internal switch of the relay, and the current flows as follows:

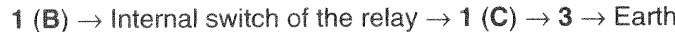

- As a result, engine is stopped in the same way as the automatic stop.

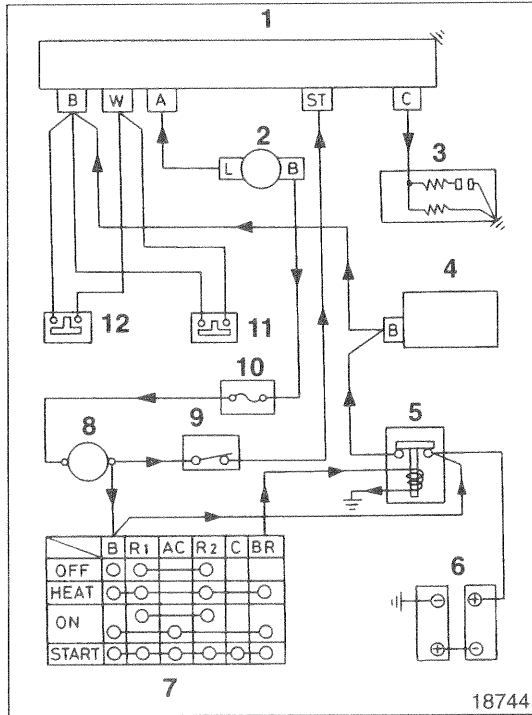

# STRUCTURE AND OPERATION

<Run-On>

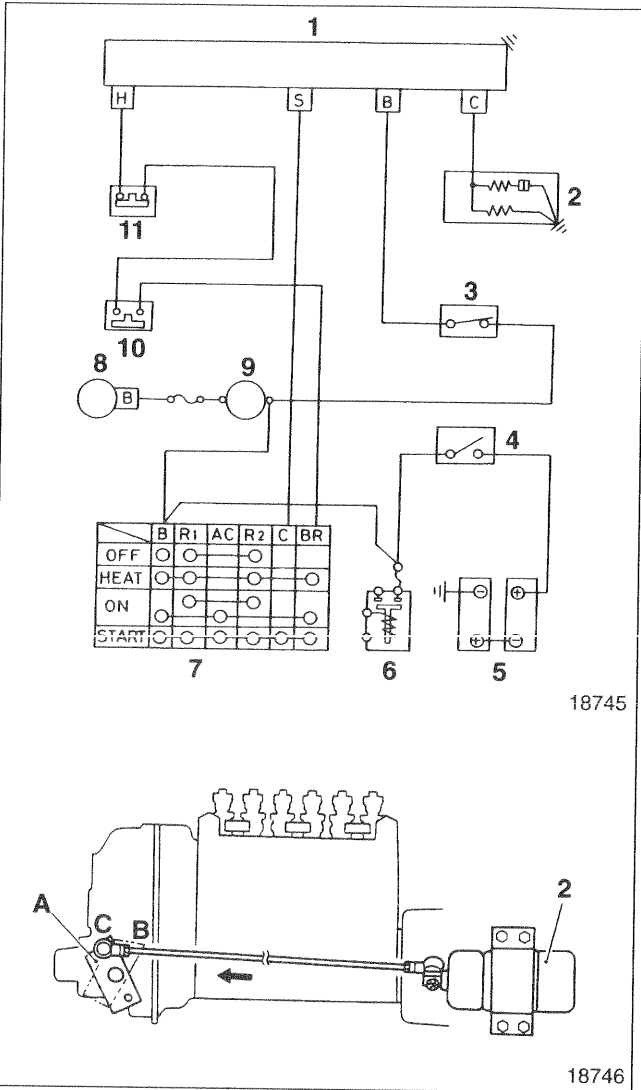

- 1 Solenoid relay
- 2 Solenoid
- 3 Stop switch
- 4 Battery switch
- 5 Battery
- 6 Heater relay
- 7 Starter switch
- 8 Alternator
- 9 Ammeter
- 10 Engine oil pressure switch
- 11 Coolant temperature sensor

B: Terminal B  
 C: Terminal C  
 H: Terminal H  
 S: Terminal S

\* When the stop switch is set to ON, the contact opens. When the switch is set to OFF, the contact closes.

- On normal condition, solenoid 2 is energized and the stop lever **A** of the injection pump governor is at the drive side **B** to keep the engine in running condition.
- When a trouble occurs, current to activate the solenoid is cut off and solenoid 3 loses its pulling force. Then the stop lever **A** is pulled to the stop side **C** by its return spring and the engine is stopped.

**Before engine starts**

Battery switch 4: ON

5 → 4 → 6 → 7 (B) → 9 → 3 → 1 (B)

As the voltage is applied to terminal B of the solenoid relay 1, but is not applied to terminal S, the solenoid relay is not energized. Therefore, current does not flow to the solenoid relay 2 and solenoid relay 2 does not operate.

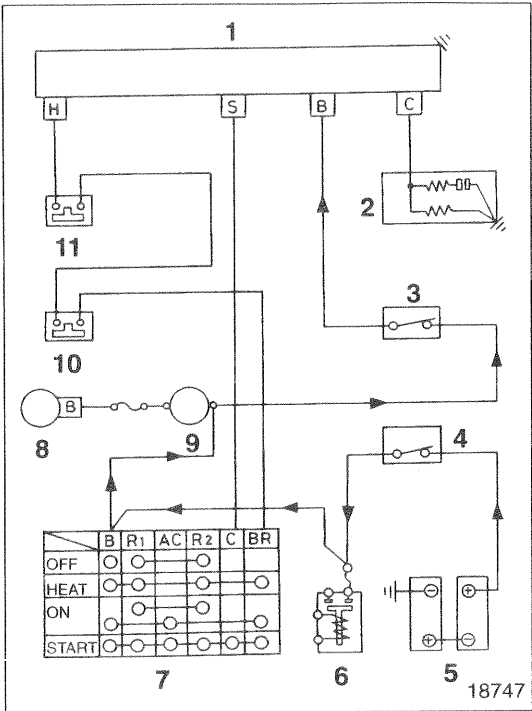

**When engine starts**

- Position of starter switch 7: START

5 → 4 → 6 → 7 (B) → 7 (C) → 1 (S) → earth

- At this point, internal switch of the solenoid relay 1 turns on and the current flows as follows:

1 (B) → Internal coil of relay → Earth  
 1 (B) → Internal switch of relay → 1 (C) → 2 → Earth

- Due to the activation of the solenoid 2, the stop lever A of the injection pump governor is pulled to the position B and the engine starts.

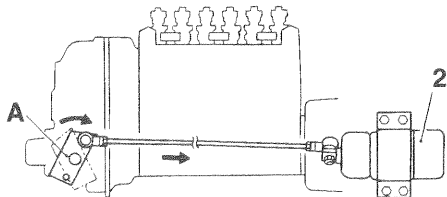
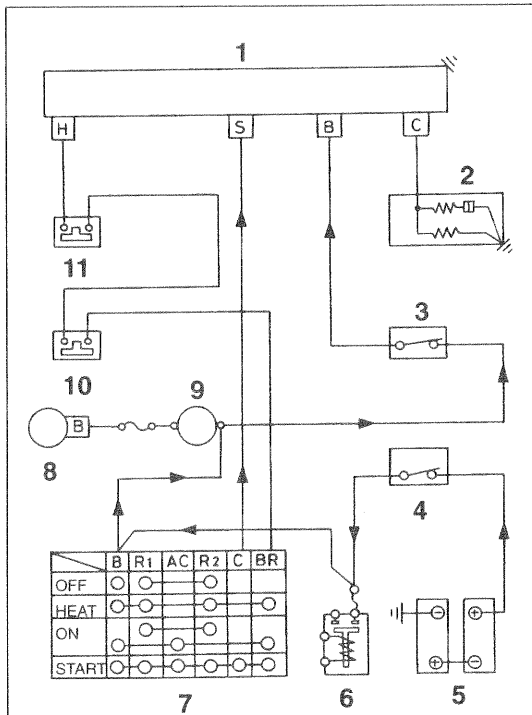

# STRUCTURE AND OPERATION

## After engine has started

- Position of starter switch 7: ON

The current from the starter switch (terminal C) to the solenoid relay 1 (terminal S) is cut off.

However, solenoid 2 remains activated as the internal switch is kept in the ON position by the capacitor in the relay.

- During this period, engine oil pressure increases to close the engine oil pressure switch 10, and the current flows as follows:

7 (BR) → 10 → 11 → 1 (H) → Internal coil of relay → Earth

- In this way, internal switch of relay is held ON to keep the engine running irrespective of the discontinuation of the current to the terminal S of the solenoid relay 1.

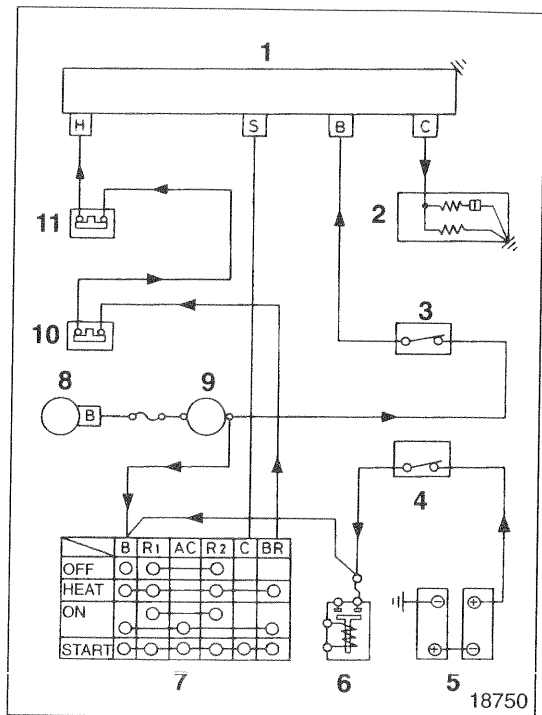

18750

## When engine is automatically stopped

When the oil pressure abnormally falls or the coolant temperature abnormally rises while the engine is running, the contact of the engine oil pressure switch 10 or coolant temperature sensor (thermo switch) 11 turns OFF to stop the supply of current to the solenoid relay, so the solenoid relay stops operating. Accordingly, the solenoid 2 also stops operating, and the stop lever A of the governor is moved to the stop position by the return spring and the engine is stopped.

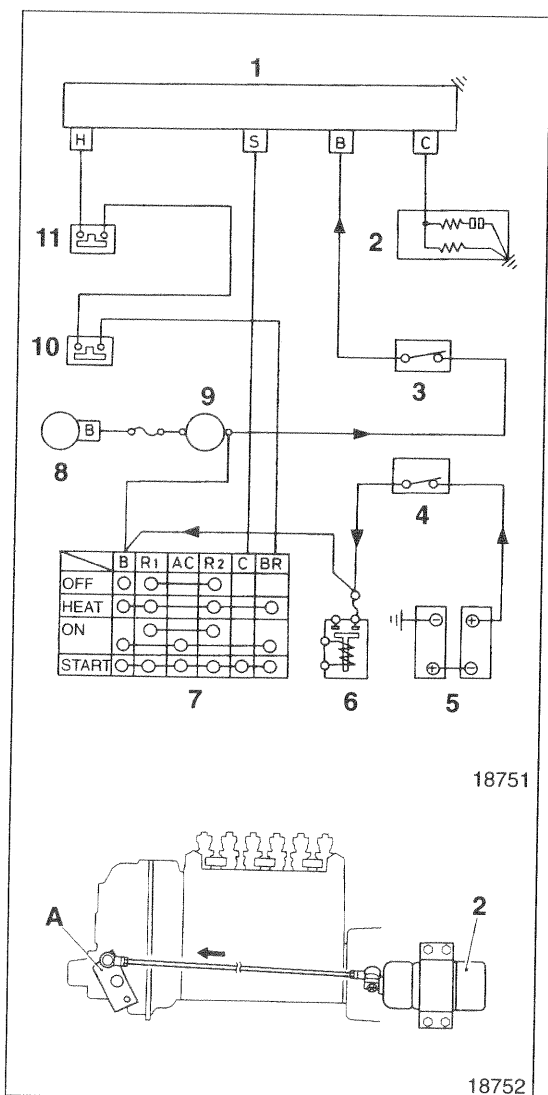

18751

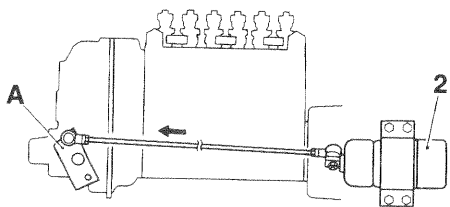

18752

**When engine is manually stopped**

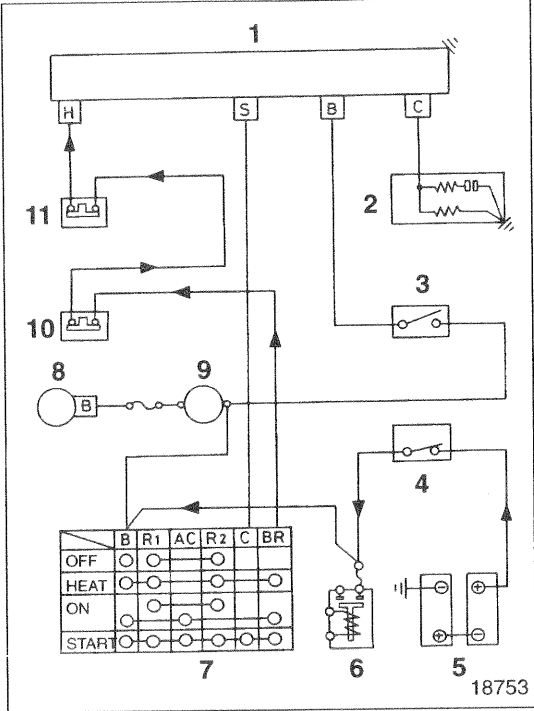

- Position of stop switch 3: ON (ON: Contact is opened; OFF: Contact is closed)

When the current to the solenoid relay 1 (terminal B) is cut off, the current from the solenoid (terminal C) to the solenoid 2 is also lost, and the engine is stopped in the same way as the automatic stop.



# TROUBLESHOOTING

## Alternator

Probable causes		Defective conditions					Remarks
		Battery fluid decreases in a short time.	Battery temperature high	Battery is normal but is over-discharged.	With the engine stationary (the starter switch at ON), the charge lamp  does not come on.	Alternator is in order but battery is over-discharged	
Connector incorrectly connected, harness open-circuited, defective grounding				<input type="radio"/>		<input type="radio"/>	
Blown fuse				<input type="radio"/>	<input type="radio"/>	<input type="radio"/>	
Weak tension of V belt				<input type="radio"/>		<input type="radio"/>	 Gr 14
Broken V belt				<input type="radio"/>		<input type="radio"/>	 Gr 14
Defective battery		<input type="radio"/>				<input type="radio"/>	
Alternator	Stator coil open-circuited			<input type="radio"/>			
	Stator coil and core short-circuited			<input type="radio"/>			
	Field coil defective			<input type="radio"/>			
	Rectifier defective			<input type="radio"/>			
	Regulator defective		<input type="radio"/>	<input type="radio"/>	<input type="radio"/>		
	Brush worn (if brush is provided)			<input type="radio"/>			
	Sagging brush spring (if brush is provided)			<input type="radio"/>			
Defective wiring				<input type="radio"/>			

**Starter**

Defective condition		Starter starts but engine does not start						Remarks
		Starter does not start	Pinion does not come in mesh with ring gear	Pinion comes in mesh with ring gear but does not rotate	Flywheel rotates but engine does not start	Engine does not stop	Engine cannot be preheated	
Possible causes								
Connector incorrectly connected, harness open-circuited, defective grounding		<input type="radio"/>			<input type="radio"/>	<input type="radio"/>	<input type="radio"/>	
Blown fuse		<input type="radio"/>						
Insufficient capacity of battery		<input type="radio"/>		<input type="radio"/>				
Starter	Contact of magnet switch binding or deposited	<input type="radio"/>						
	Coil of magnet switch open-circuited	<input type="radio"/>						
	Overrunning clutch in defective operation		<input type="radio"/>					
	Worn or damaged pinion		<input type="radio"/>					
Defective starter relay		<input type="radio"/>						
Defective starter switch		<input type="radio"/>				<input type="radio"/>		
Worn or damaged ring gear of flywheel			<input type="radio"/>					📖 Gr 11

**Starter, Preheater**

Defective condition		Engine hard to start		Remarks
		Engine hard to start	Engine cannot be preheated	
Possible causes				
Defective heater relay or glow relay wiring		<input type="radio"/>	<input type="radio"/>	
Defective battery wiring		<input type="radio"/>	<input type="radio"/>	
Defective air heater or glow plug wiring		<input type="radio"/>	<input type="radio"/>	
Defective air heater or glow plug		<input type="radio"/>	<input type="radio"/>	
Defective coolant temperature sensor		<input type="radio"/>		📖 Gr 14
Defective coolant temperature sensor wiring		<input type="radio"/>		

# ON-VEHICLE INSPECTION AND ADJUSTMENT

## 1. Inspection of Preheater System <Glow Plug Specification>

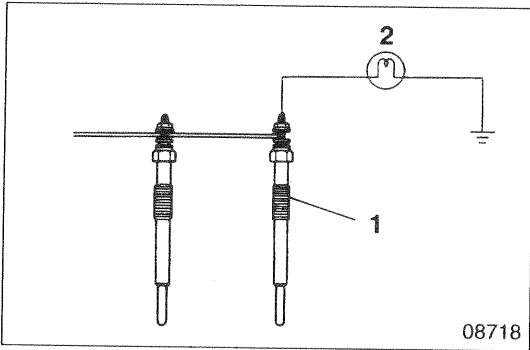

- Set the starter switch to OFF.
- Connect the inspection lamp 2 (24V-1.8W or thereabouts) to the glow plug 1.
- Set the starter switch to the HEAT position.
- If the inspection lamp 2 does not come on, check the glow plug or heater relay.

## 2. Inspection of Safety Relay

### Service standards

Unit: mm

Location	Maintenance item	Standard value	Limit	Remedy	
6	Output voltage at terminal P	When engine is stationary	1V or less	—	Replace alternator or wiring.
		While engine is running (at idle, 600 rpm or more)	12 - 16V	—	Check and replace wiring.
	Output voltage at terminal R	While engine is running	Approx. 24V	—	Check and replace wiring.
	Output voltage at terminal S	When engine is started (in cranking state)	1V or less	—	<ul style="list-style-type: none"> <li>• If the output voltage is close to the battery voltage, replace the safety relay.</li> <li>• If the output voltage is 0V, check and replace parts</li> </ul>
	Output voltage at terminal L	While engine is running	5V or less (but not 0V)	—	<ul style="list-style-type: none"> <li>• Replace</li> <li>• If the output voltage is close to the battery voltage, inspect the alternator and harness and replace if necessary.</li> </ul>

(1) Checking output voltage at terminal P

- Connect the voltmeter (pointer type) 7 as shown.

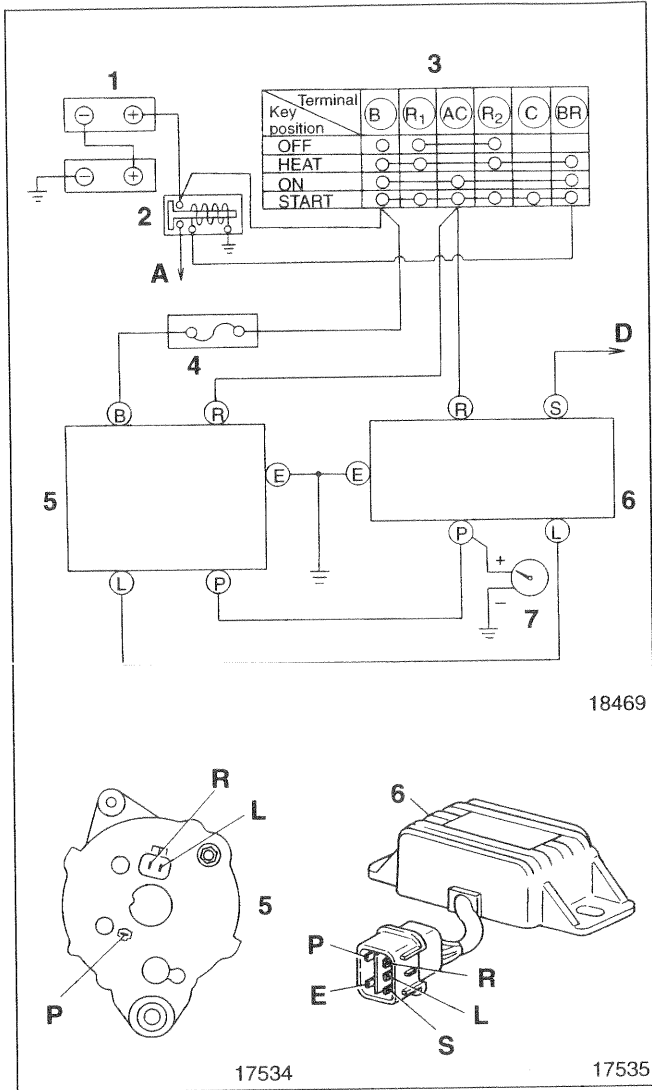

- 1 Battery
- 2 Battery relay
- 3 Starter switch
- 4 Fuse
- 5 Alternator
- 6 Safety relay
- 7 Voltmeter (pointer type)

- A: To terminal B of starter relay
- D: To terminal L of starter relay
- E: Terminal E
- L: Terminal L
- P: Terminal P
- R: Terminal R
- S: Terminal S

- Measure the voltage between terminal P in the illustration and the ground.
- If the reading is out of the standard value, the alternator 5 or wiring is defective. Check all the parts and replace defective ones.
- Start the engine and let it run at idle (600 rpm or more) and measure the voltage.
- If the reading is 0V, the wiring to terminal P is short-circuited. Check the wiring and connector connections. Replace if defective.

# ON-VEHICLE INSPECTION AND ADJUSTMENT

## (2) Checking output voltage at terminal R

- Connect the voltmeter 7 as shown.
- Place the starter switch 3 in the ON position and measure the voltage.
- When the reading is out of the standard value, check the wiring. Replace if defective.

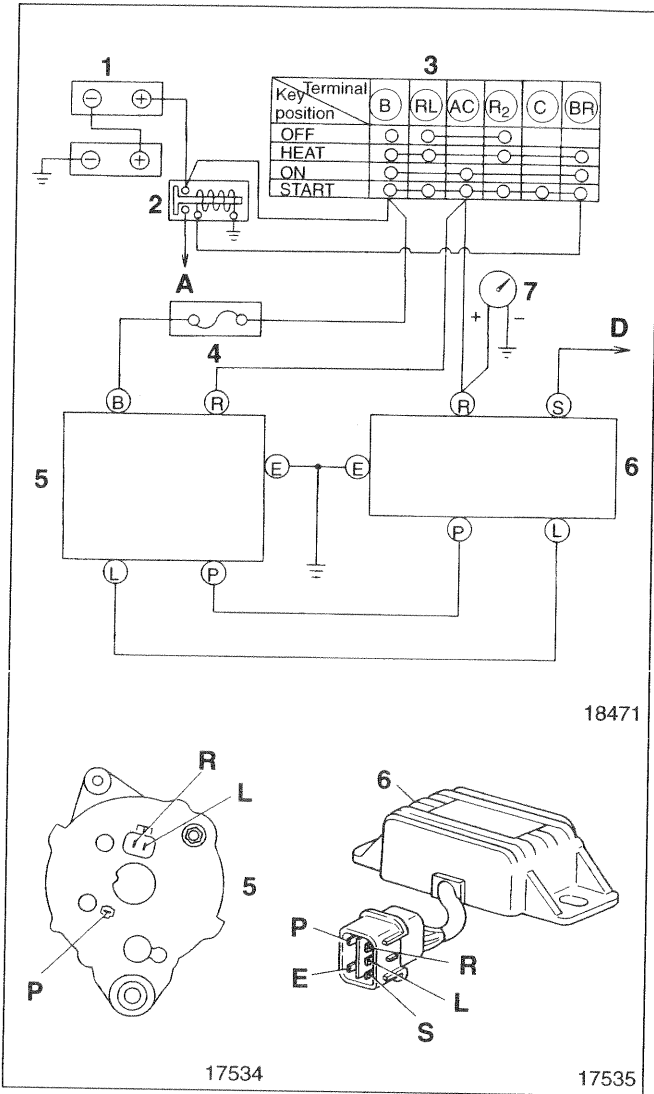

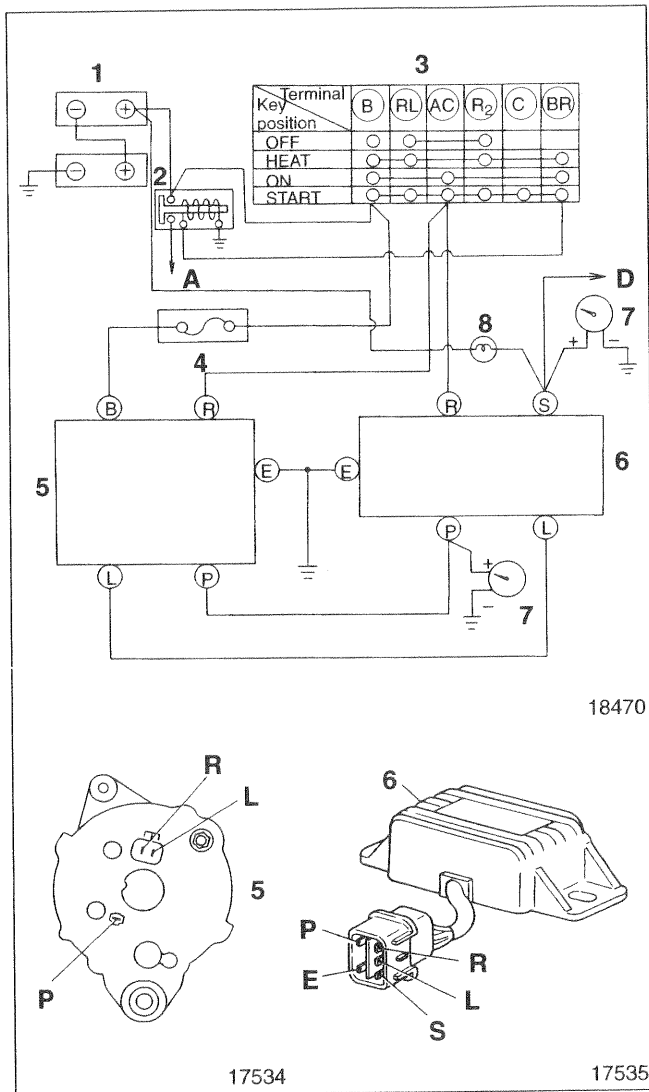

### (3) Checking output voltage at terminal S

- Connect the voltmeter 7 and lamp 8 as shown.
  - Set the starter switch 3 to the START position and measure the voltage between the safety relay 6 (terminal S) and the earth in the cranking state.
  - If the reading is out of the standard value, the following points are likely to be defective. Check all the points and replace if defective.
    - When the reading is close to the battery voltage, the safety relay 6 is defective.
    - When the reading is 0V, the following problems are suspected.
      - Defective wiring
      - Incorrectly connected connector
      - Defective starter relay
      - Defective starter switch
  - Start the engine and let it run at idle (600 rpm or more).
  - Measure the voltage at terminal P.
  - If the reading is out of the standard value, replace the alternator 5.
  - In the idling state, check to ensure that the lamp 8 does not come on.
- When the voltage at terminal P is normal and the lamp comes on, replace the safety relay 6.

# ON-VEHICLE INSPECTION AND ADJUSTMENT

## (4) Checking output voltage at terminal L (where no charge lamp is provided)

- Connect the voltmeter 7 as shown.
  - Place the starter switch 3 at the ON position and measure the voltage.
  - If the reading is out of the standard value, replace the safety relay 6.
- If the reading is close to the battery voltage, check the alternator 5 and wiring, and replace if defective.

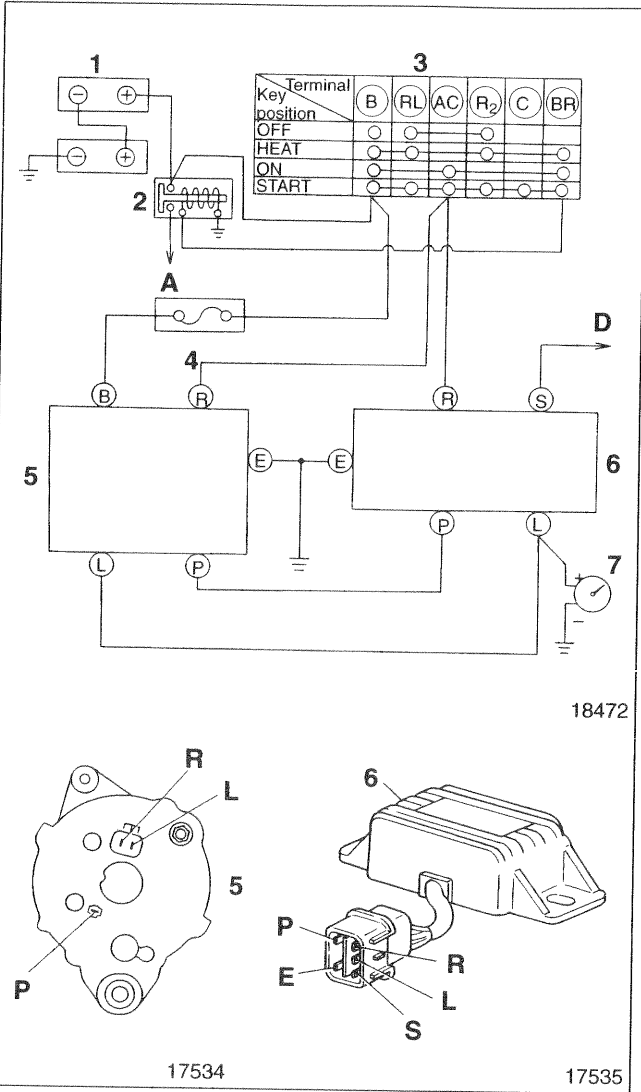

### 3. Automatic Stop System

<Shutdown>

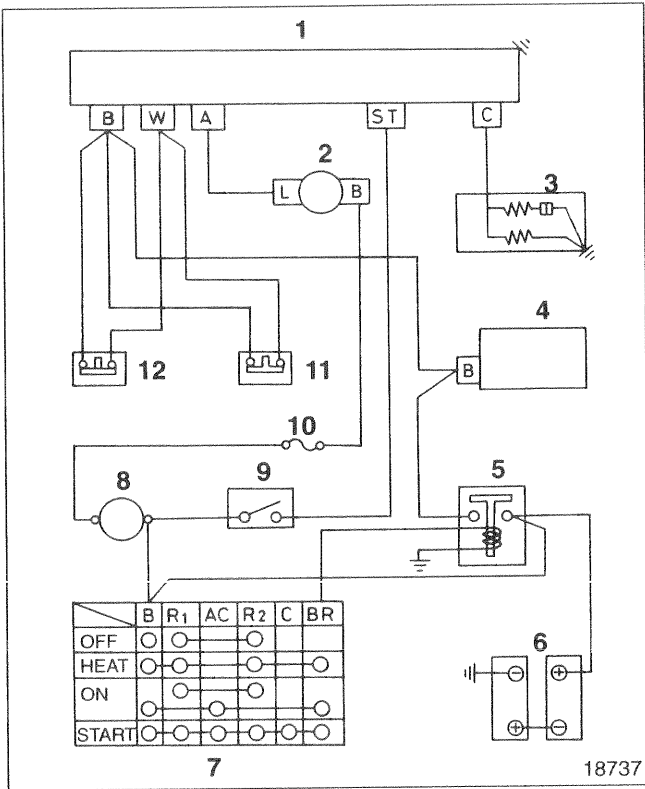

- 1 Solenoid relay
- 2 Alternator
- 3 Solenoid
- 4 Starter
- 5 Battery relay
- 6 Battery
- 7 Starter switch
- 8 Ammeter
- 9 Stop switch
- 10 Fuse box
- 11 Engine oil pressure switch
- 12 Water temperature sensor

Measure the voltages at the terminals of the solenoid relay 1. Perform checks as described below and replace defective parts.

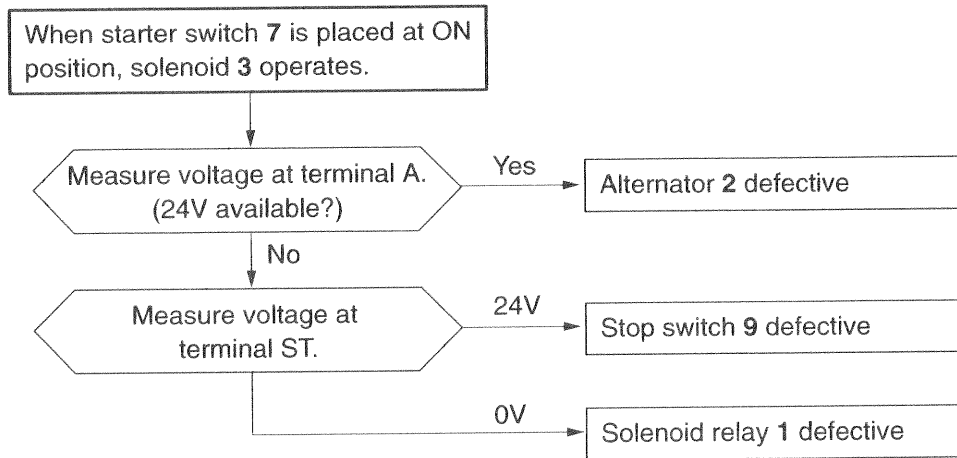

# ON-VEHICLE INSPECTION AND ADJUSTMENT

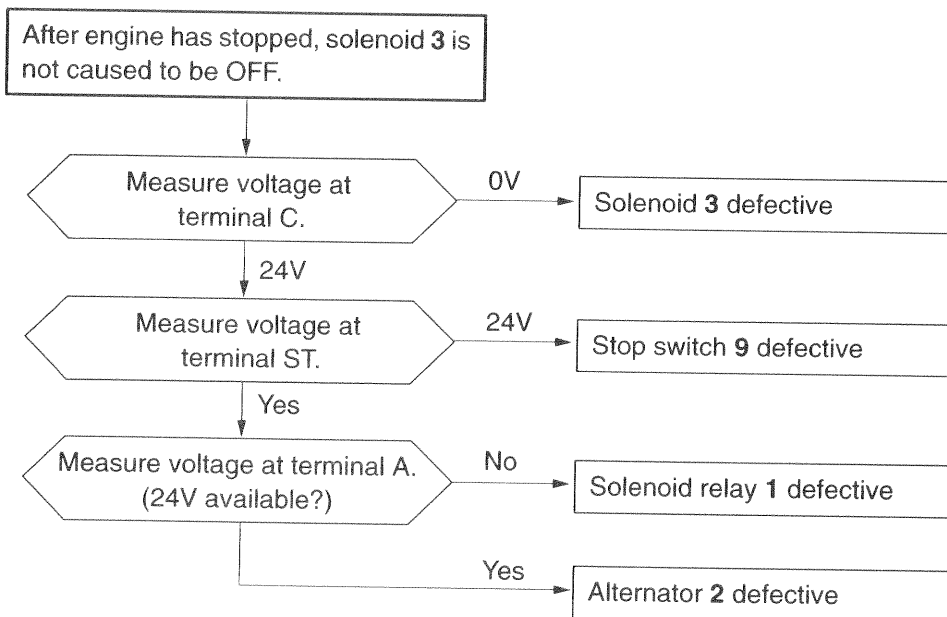
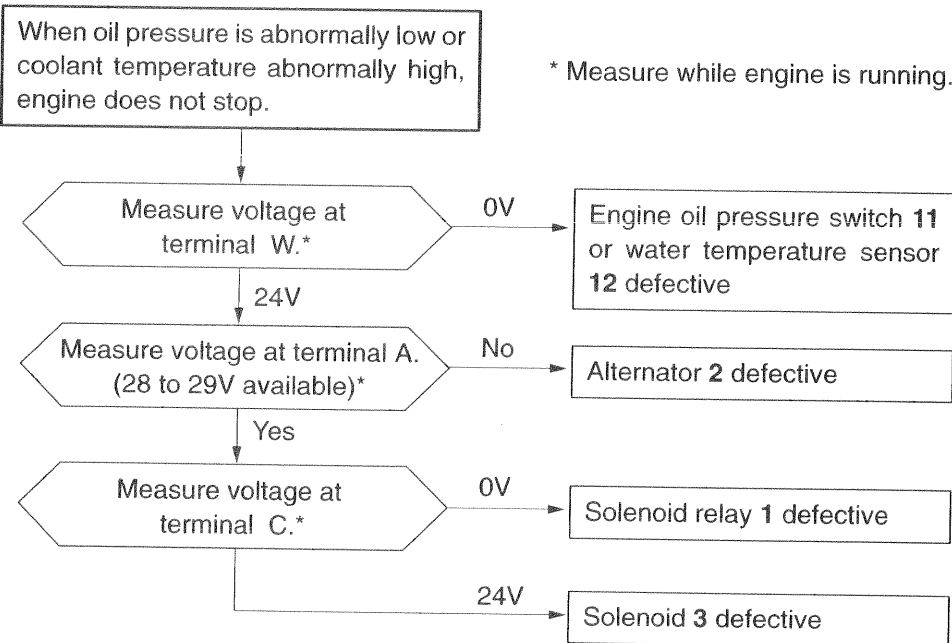
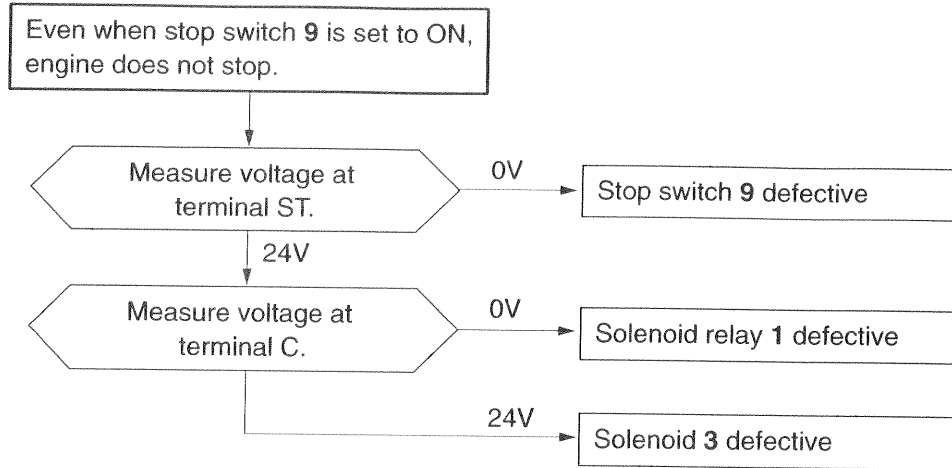

While engine is running, solenoid 3 is operated and engine stops.

\* Measure while engine is running.

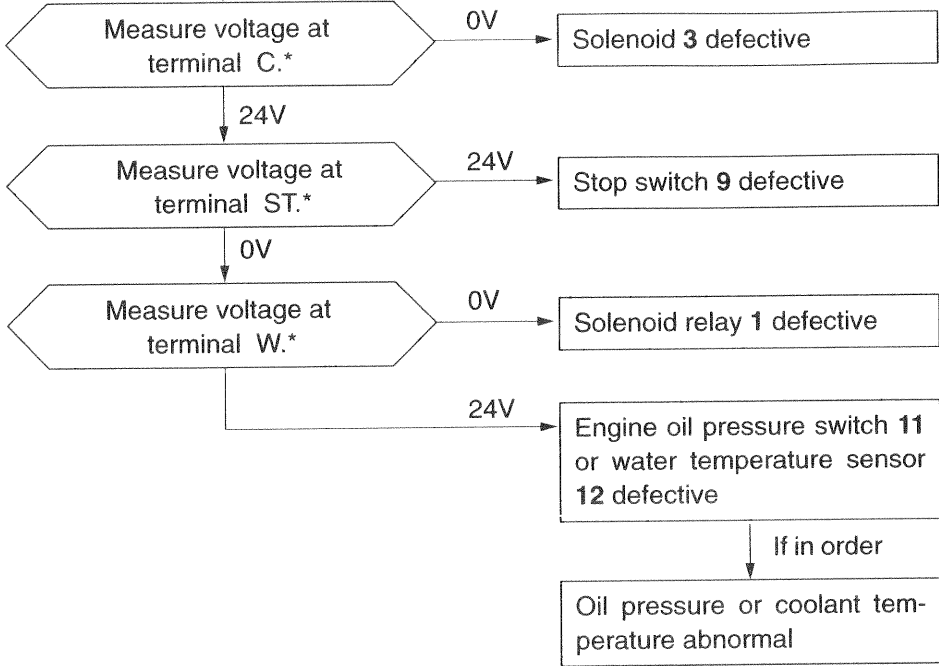

# ON-VEHICLE INSPECTION AND ADJUSTMENT

<Run-On>

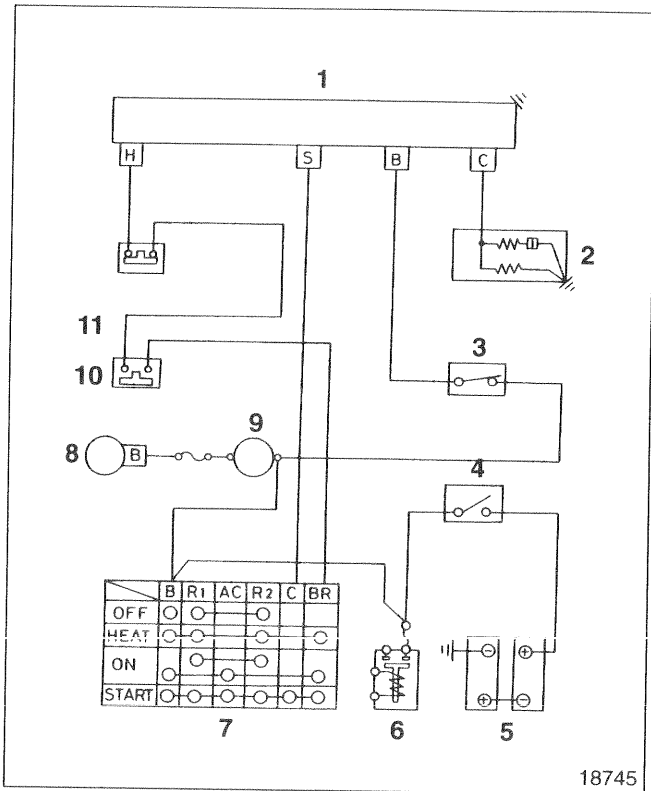

- 1 Solenoid relay
- 2 Solenoid
- 3 Stop switch
- 4 Battery switch
- 5 Battery
- 6 Heater relay
- 7 Starter switch
- 8 Alternator
- 9 Ammeter
- 10 Oil pressure switch
- 11 Water temperature sensor

Measure the voltages at the terminals of the solenoid relay 1. Perform checks as described below and replace defective parts.

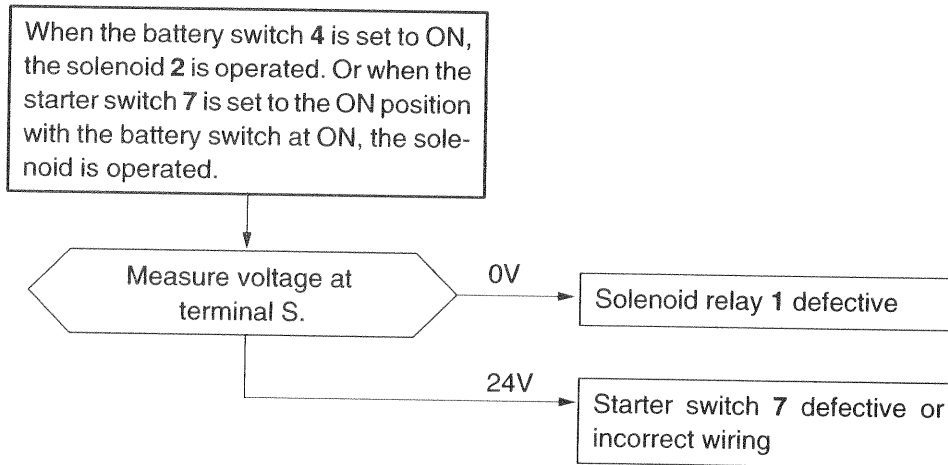

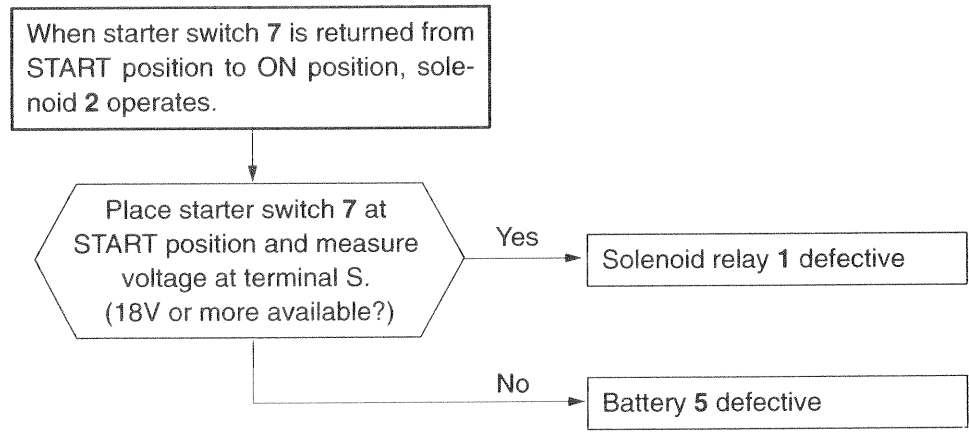
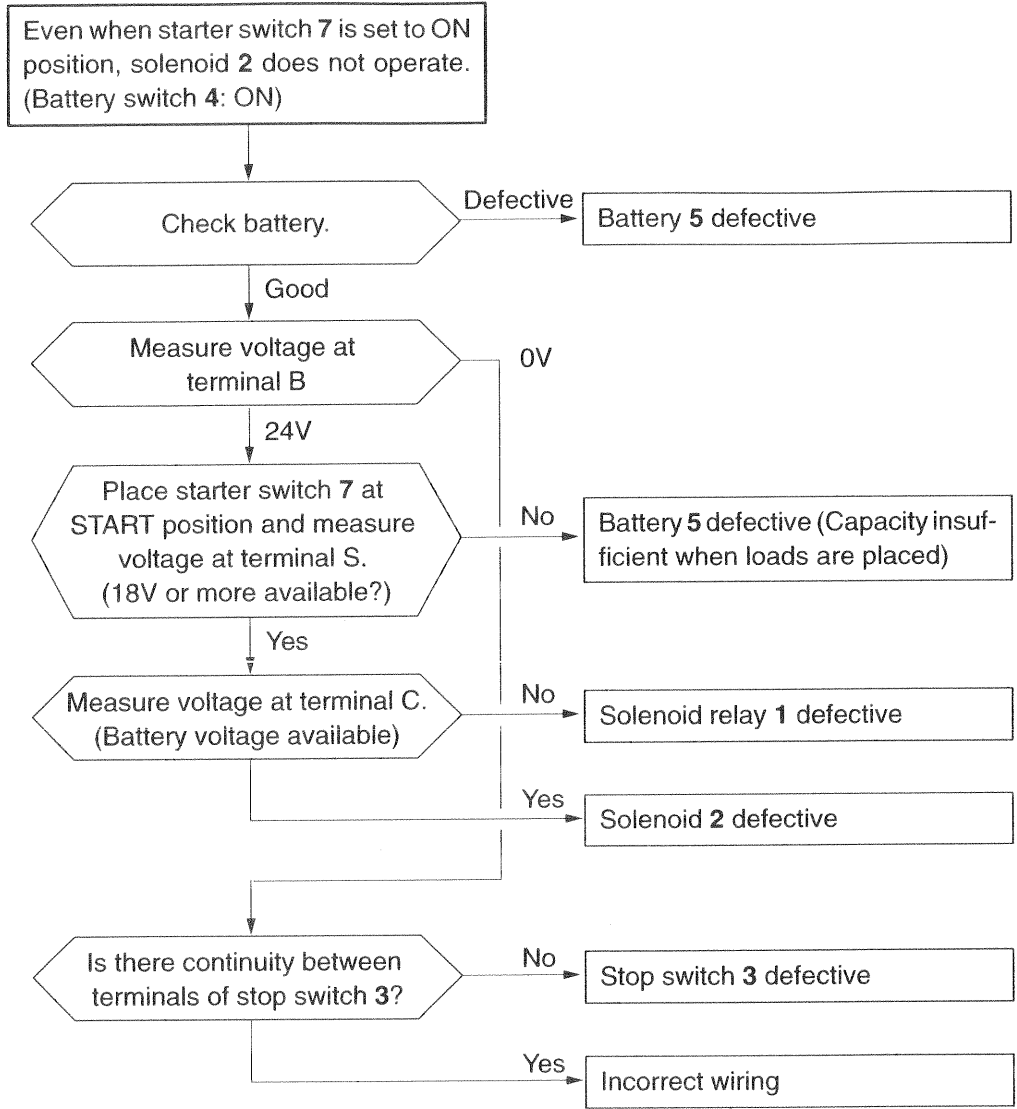

# ON-VEHICLE INSPECTION AND ADJUSTMENT

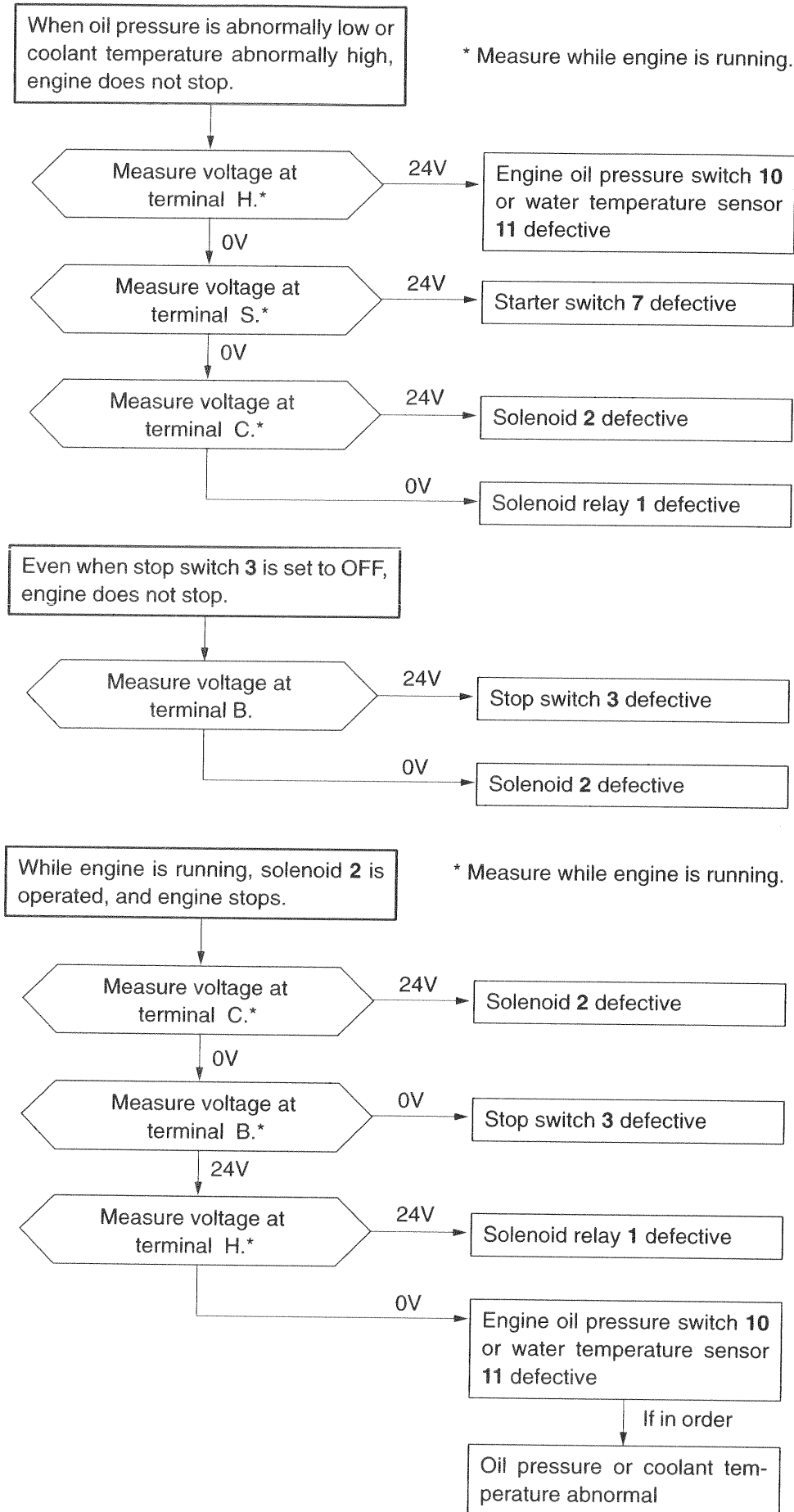

---

**MEMO**

---

# ALTERNATOR <24V-35A>

<Type A>

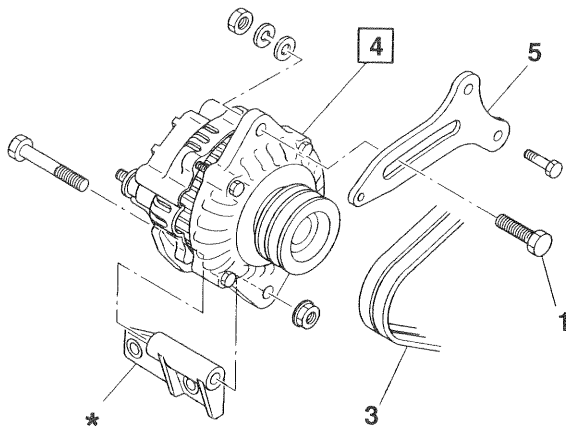

©16745

<Type B>

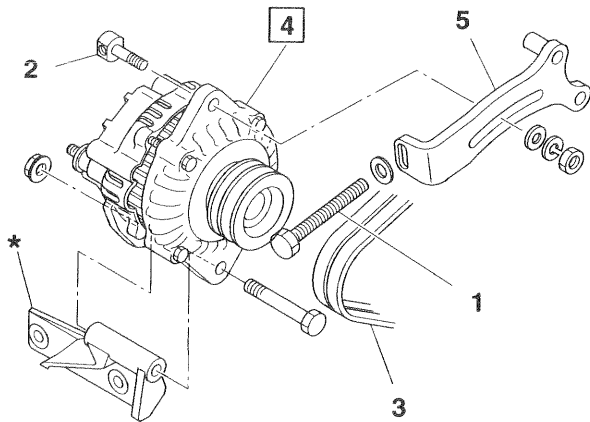

©46895

## ● Removal sequence

- 1 Adjust bolt
- 2 Adjust shaft <Type B>
- 3 V belt
- 4 Alternator assembly P.54-48
- 5 Adjust plate

\*: Alternator bracket

## WARNING

Before removing the alternator 4, be sure to disconnect the negative  $\ominus$  terminal of the battery and insulate it with a tape or something else. If the negative  $\ominus$  terminal is not disconnected, the battery voltage is always available at terminal B and is dangerous.

## ● Installation sequence

Reverse the order of removal.

## ● Adjustment after installation

Adjust the tension of the V-belt 3. Gr 14

## Service standards

Location	Maintenance item		Standard value	Limit	Remedy	
4	Alternator output current (* When hot, when 27V is generated)	Alternator speed	1500 rpm	20A or more	—	Check
			2500 rpm	29A or more		
			5000 rpm	33A or more		
	Regulator regulated voltage (5000 rpm, loads 5A or less)			28.5 ± 0.5V	—	Replace

\*: "When hot" refers to the state of the engine after 30 minutes of maximum output operation at 5000 rpm at a normal ambient temperature.

## ◆ Service procedure

### 4 Inspection of alternator

#### (1) Inspection of performance of alternator

(Inspection by test bench)

- Wire the alternator 4 as shown.

#### NOTE

Each wire must be adequately thick and each connection must be properly secured.

- A: Ammeter
- B: Alternator terminal B
- C: Switch
- D: Switch
- E: Alternator terminal E
- F: Load resistance (variable resistance)
- G: Alternator drive motor
- L: Alternator terminal L
- R: Alternator terminal R
- V: Voltmeter

- Increase the load resistance **F** to a maximum (where practically no load current flows).
- Set the switch **C** and switch **D** to ON.
- Operate the alternator **4** at 5000 rpm for 30 minutes with the load resistance **F** adjusted such that the output current is as specified in "Service standard".

Nominal value of alternator current

24V-35A

- Measure the current with the alternator **4** at each of the specified speeds.
- If the reading is out of the standard value, disassemble and check the alternator **4**. P.54-48

#### (2) Inspection of performance of regulator

(Inspection by test bench)

- Wire the alternator **4** as shown.

- A: Ammeter
- B: Alternator terminal B
- C: Switch
- E: Alternator terminal E
- G: Alternator drive motor
- L: Alternator terminal L
- R: Alternator terminal R
- V: Voltmeter

- Set the switch **C** to ON.
- Let the alternator **4** rotate at a low speed.
- Increase the rotating speed of the alternator **4** to 5000 rpm and measure the voltage (regulated voltage). At the same time, check to ensure that the current value is 5A or less.
- If the readings are out of the standard values, proceed as described below.
  - If the readings exceed the standard values, replace the regulator.
  - If the readings are below the standard values, check all the parts of the alternator before replacing the regulator.

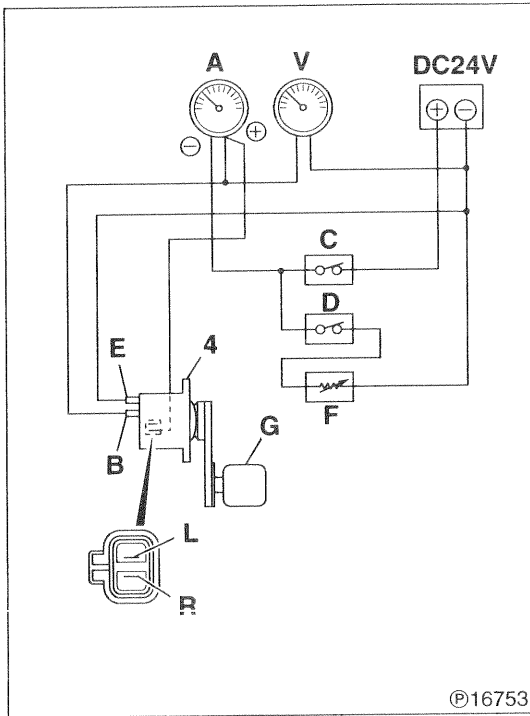

©16753

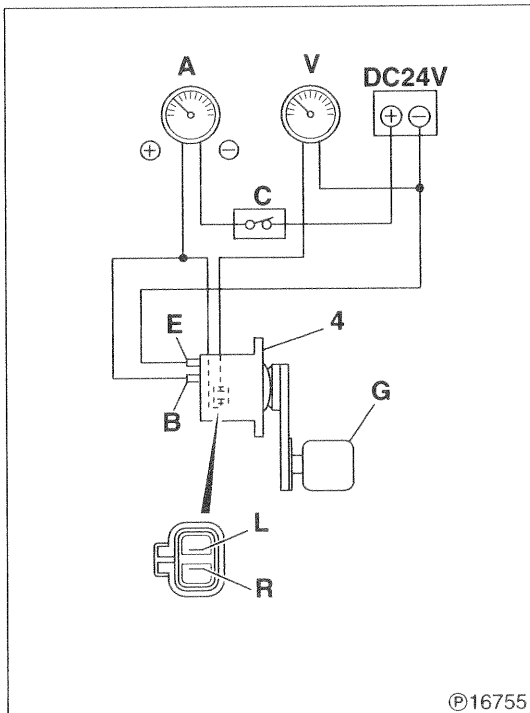

©16755

# ALTERNATOR <24V-35A>

## Alternator Assembly

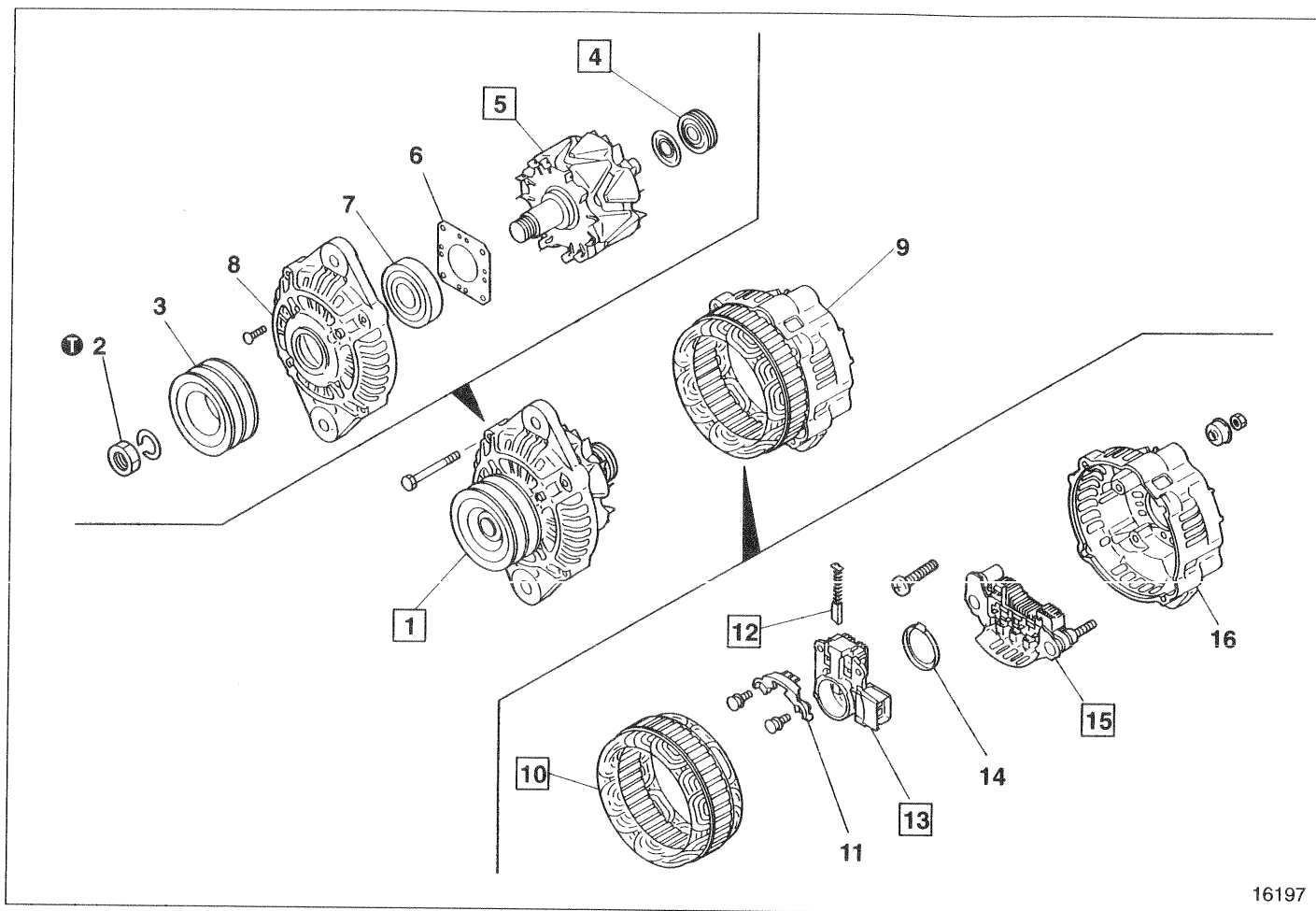

16197

### ● Disassembly sequence

- |                                    |                                    |  |
|------------------------------------|------------------------------------|--|
| 1 Rotor and front bracket assembly | 7 Front bearing                    | 13 Regulator and brush holder<br>P.54-47 |
| 2 Nut                              | 8 Front bracket                    | 14 Slinger                               |
| 3 Pulley                           | 9 Stator and rear bracket assembly | 15 Rectifier                             |
| 4 Rear bearing                     | 10 Stator assembly                 | 16 Rear bracket                          |
| 5 Rotor assembly                   | 11 Cover                           |  |
| 6 Cover                            | 12 Brush                           |  |

### NOTE

Do not remove parts 4, 7, 10 and 12 unless they are found to be defective.

### ● Reassembly sequence

9 → 1

9: 14 → 13 → 12 → 11 → 15 → 16 → 10

1: 8 → 7 → 6 → 5 → 4 → 3 → 2

## Service standards

Unit: mm

Location	Maintenance item	Standard value	Limit	Remedy
5	Rotor assembly	Field coil resistance (at 20°C)	9 to 10.5 Ω	—
		Slip ring outside diameter	33	32.4
12	Brush length	21.5	8	Replace

## ① Tightening torques

Unit: N·m {kgf·m}

Location	Parts to be tightened	Tightening torque	Remarks
2	Nut (to mount pulley)	132 to 162 {13.5 to 16.5}	—

## ◆ Service procedure

## ① Rotor &amp; front bracket assembly

[Removal]

- Insert a plain screwdriver **A** between the front bracket **8** and stator assembly **10**.
- While wrenching the plain screwdriver **A**, remove the rotor & front bracket assembly **1** from the stator & rear bracket assembly **9**.

**CAUTION** ⚠

If the plain screwdriver **A** is inserted too far, the coil **B** of the stator assembly **10** might be damaged and short-circuited.

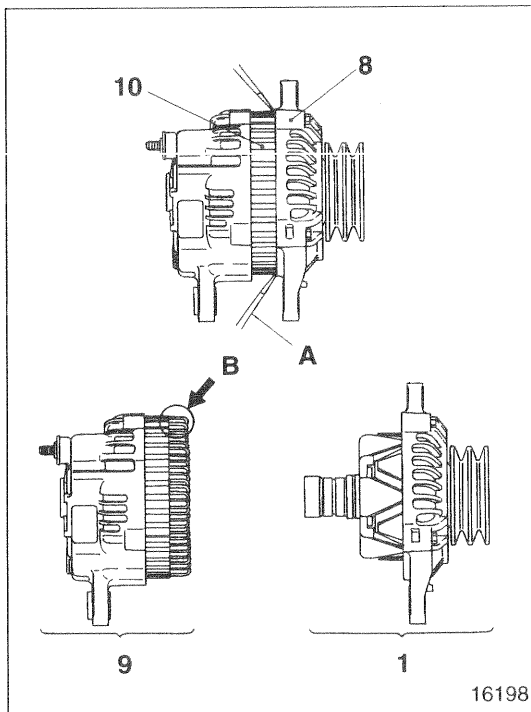

16198

[Installation]

If the brush **12** is protruding from the regulator & brush holder **13**, the rotor assembly **5** cannot be mounted on the rear bracket **16**. Therefore, perform the following steps.

- Push the brush **12** into the regulator & brush holder **13**.
- Insert the pin **C** from the rear of the rear bracket **16** and press the pin **C** against the pin hole **D** to hold the brush **12**.  
If the brush **12** is worn and the pin hole **D** gone, hold the end of the brush **12** with the pin **C**.
- After installation, slowly remove the pin **C**.

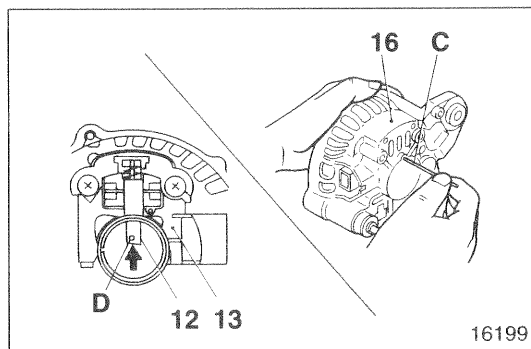

16199

# ALTERNATOR <24V-35A>

[Disassembly]

## CAUTION

When the rotor assembly 5 is held in a vice, make sure that the base E of the lugs of the core is held.

If the lugs F of the core are held, they will be broken or damaged.

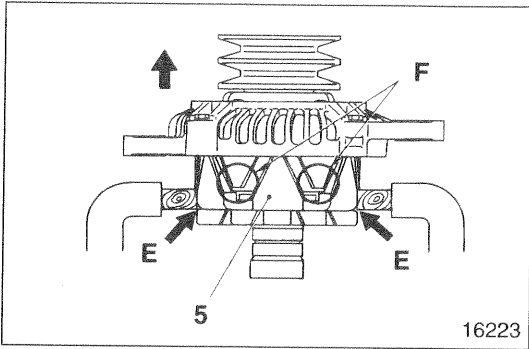

## 4 Removal of rear bearing

### CAUTION

When the bearing puller is installed, use care to prevent damage to the slip ring A.

If the slip ring is damaged, the brush will fail to make good contact.

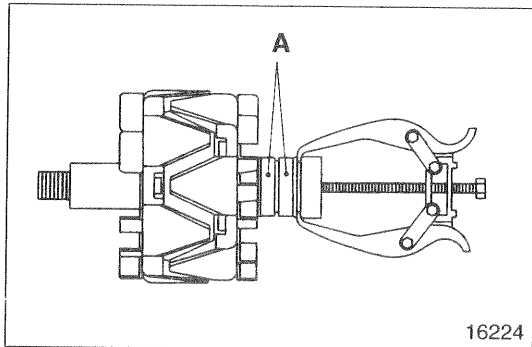

## 5 Inspection of rotor assembly

### (1) Resistance of field coil

- Measure the resistance across the slip ring A.
- If the reading is out of the standard value, replace the rotor assembly 5.

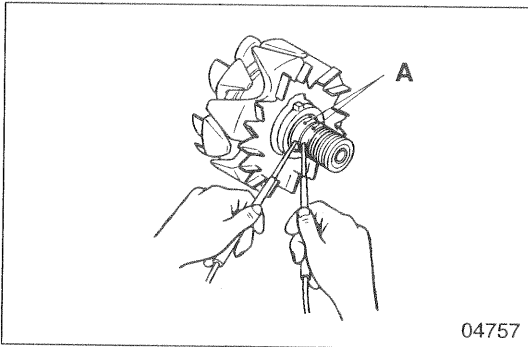

### (2) Continuity between slip ring and core

- Check to ensure that there is no continuity between slip ring A and core B.
- If there is continuity, it means a short circuit. Therefore, replace the rotor assembly 5.

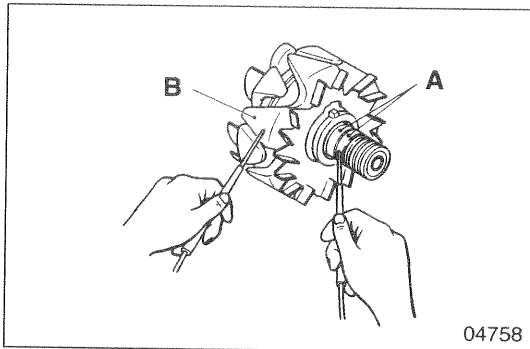

### (3) Outside diameter of slip ring

- If the outside diameter of the slip ring A is below the limit, replace the rotor assembly 5.
- If the outside diameter of the slip ring A is rough or unevenly worn, correct by grinding with emery paper or a lathe.

### CAUTION

Do corrective grinding within the extent that the outside diameter of the slip ring A does not exceed the limit.

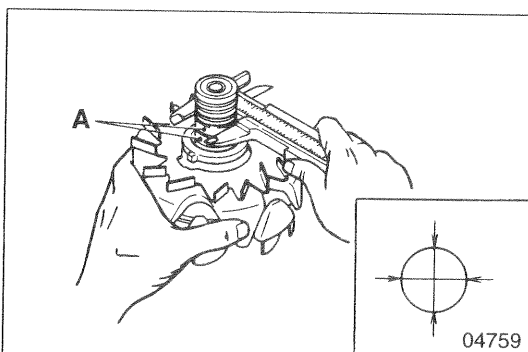

**10 Stator assembly**

[Removal]

- Disconnect the leads **A** and remove the stator assembly **10** from the rectifier **15**.  
The leads are soldered to the diode leads **B** of the rectifier. (Three places)

**CAUTION** ⚠

De-soldering should be done quickly (in about 5 seconds or less).  
The diodes will be damaged if heated for a longer time.

- For installation, reverse the order of removal.

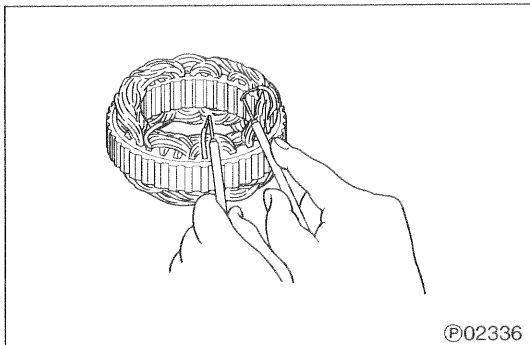
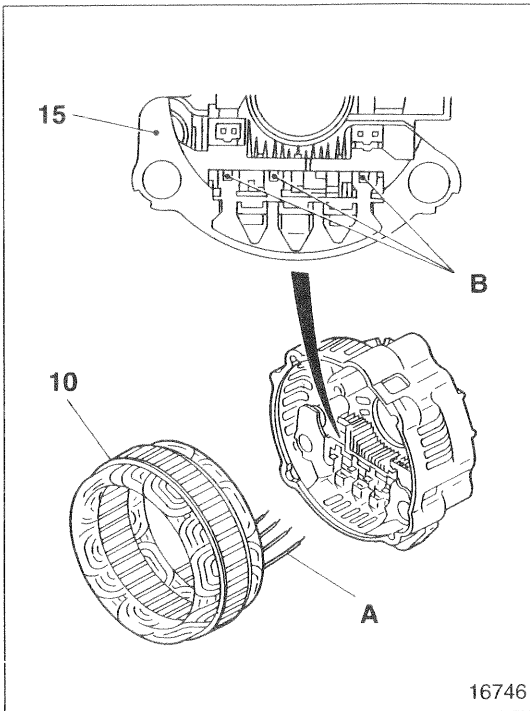

[Inspection]

**(1) Continuity between leads**

- Check to ensure that there is continuity between each lead.
- If there is no continuity, the leads are open-circuited. Replace the stator assembly **10**.

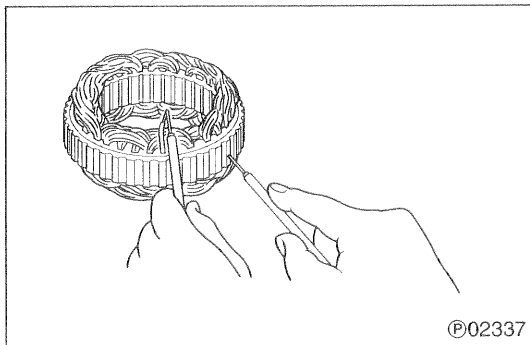
**(2) Continuity between each lead and core**

- Check to ensure that there is no continuity between each lead and the core.
- If there is continuity, it means a short circuit. Replace the stator assembly **10**.

**12 Brush**

[Removal]

After removing the cover **A**, de-solder the leads of the brush **12** and remove the brush from the regulator & brush holder **13**.

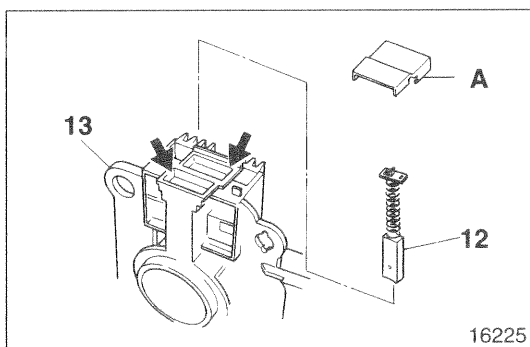

# ALTERNATOR <24V-35A>

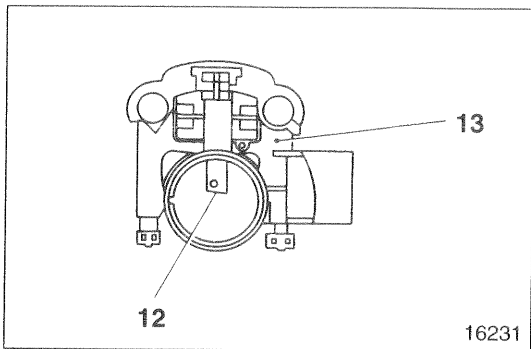

## [Installation]

- Install the brush 12 in the regulator & brush holder 13 in the direction shown.
  - After installation, solder the leads of the brush 12 to the regulator & brush holder 13.
- Thereafter, fit the cover A as before.

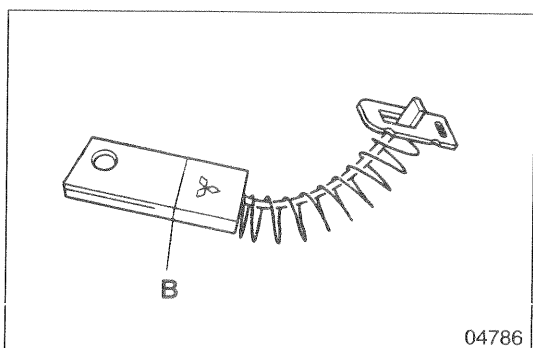

## [Inspection]

If the length of the brush 12 is near the wear limit B, replace.

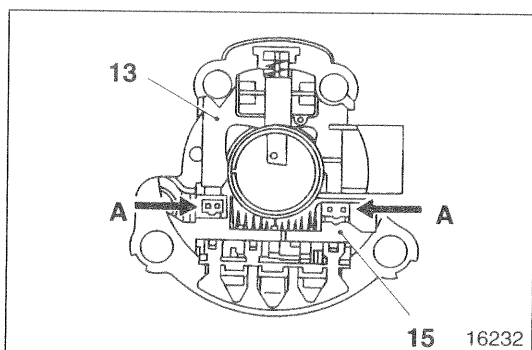

## 13 Removal of regulator & brush holder

- Remove the regulator & brush holder 13 by de-soldering the two illustrated points A.
- For installation, reverse the order of removal.

## 15 Inspection of rectifier

- Check the rectifier 15 to see if the internal diodes function properly.

Resistance infinite in both cases...Open  
Resistance close to  $\Omega$  in both cases...Short

A, B, C, D: Leads of stator coil connected  
E, G: Heat sink portion  
F: Regulator connected

- Exchange the  $\oplus$  and  $\ominus$  sides of the tester and perform checks in both cases.

## CAUTION

When a tester is used for the checks, the current that flows out from the tester is feebler than the current that normally flows through the rectifier 15, so the tester may indicate a questionable resistance value. In a low range, this tendency will be stronger. Therefore, it is advisable to use the highest possible range.

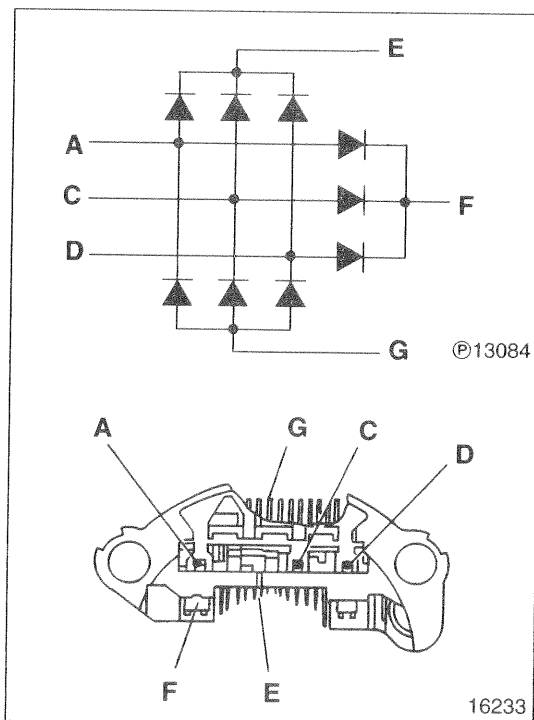

---

**M E M O**

---

# ALTERNATOR <24V-80A (with brush)>

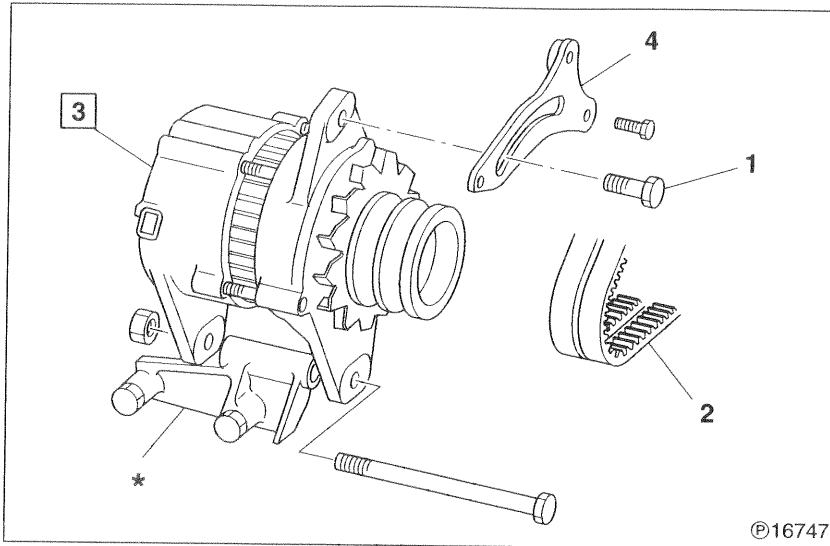

## ● Removal sequence

- 1 Adjust bolt
- 2 V-belt
- 3 Alternator assembly P.54-56
- 4 Adjust plate

\*: Alternator bracket

## WARNING

Before removing the alternator 3, be sure to disconnect the negative  $\ominus$  terminal of the battery and insulate it with a tape or something else. If the negative  $\ominus$  terminal is not disconnected, the battery voltage is always available at terminal B and is dangerous.

## ● Installation sequence

Reverse the order of removal.

## ● Adjustment after installation

Adjust the tension of the V-belt 2. Gr 14

## Service standards

Location	Maintenance item		Standard value	Limit	Remedy	
3	Alternator output current (* When hot, when 27V is generated)	Alternator speed	1500 rpm	32A or more	—	Check
			2500 rpm	64A or more	—	
			5000 rpm	78A or more	—	
	Regulator regulated voltage (5000 rpm, loads 5A or less)		28.5 ± 0.5V	—	Replace	

\*: "When hot" refers to the state of the engine after 30 minutes of maximum output operation at 5000 rpm at a normal ambient temperature.

## ◆ Service procedure

### 3 Inspection of alternator

#### (1) Inspection of performance of alternator (Inspection by test bench)

- Wire the alternator 3 as shown.

#### NOTE

Each wire must be adequately thick and each connection must be properly secured.

- A: Ammeter
- B: Alternator terminal B
- C: Switch
- D: Switch
- E: Alternator terminal E
- F: Load resistance (variable resistance)
- G: Alternator drive motor
- L: Alternator terminal L
- R: Alternator terminal R
- V: Voltmeter

- Increase the load resistance **F** to a maximum (where practically no load current flows).
- Set the switch **C** and switch **D** to ON.
- Operate the alternator **3** at 5000 rpm for 30 minutes with the load resistance **F** adjusted such that the output current is as specified in "Service standard".

Nominal value of alternator current

24V-80A

- Measure the current with the alternator **3** at each of the specified speeds.
- If the reading is out of the standard value, disassemble and check the alternator **3**. P.54-56

#### (2) Inspection of performance of regulator (Inspection by test bench)

- Wire the alternator **3** as shown.

- A: Ammeter
- B: Alternator terminal B
- C: Switch
- E: Alternator terminal E
- G: Alternator drive motor
- L: Alternator terminal L
- R: Alternator terminal R
- V: Voltmeter

- Set the switch **C** to ON.
- Let the alternator **3** rotate at a low speed.
- Increase the rotating speed of the alternator **3** to 5000 rpm and measure the voltage (regulated voltage). At the same time, check to ensure that the current value is 5A or less.
- If the readings are out of the standard values, proceed as described below.
  - If the readings exceed the standard values, replace the regulator.
  - If the readings are below the standard values, check all the parts of the alternator before replacing the regulator.

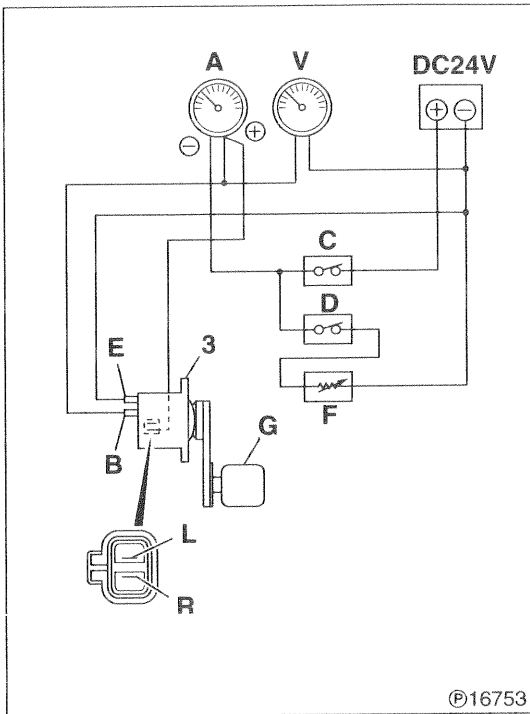

©16753

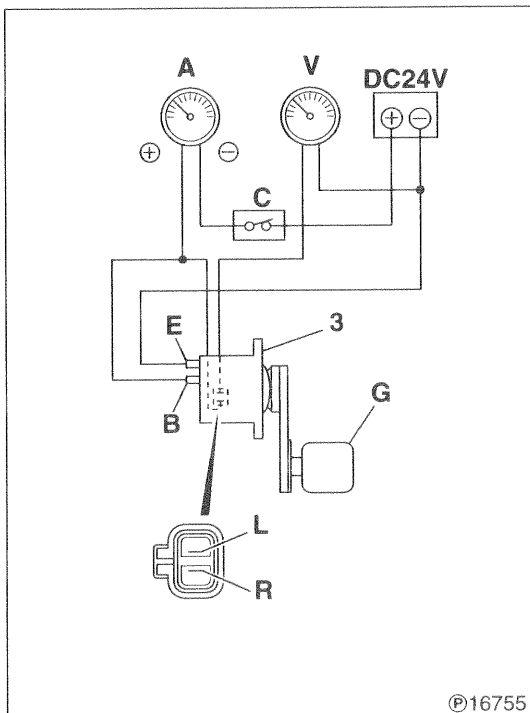

©16755

# ALTERNATOR <24V-80A (with brush)>

## Alternator Assembly

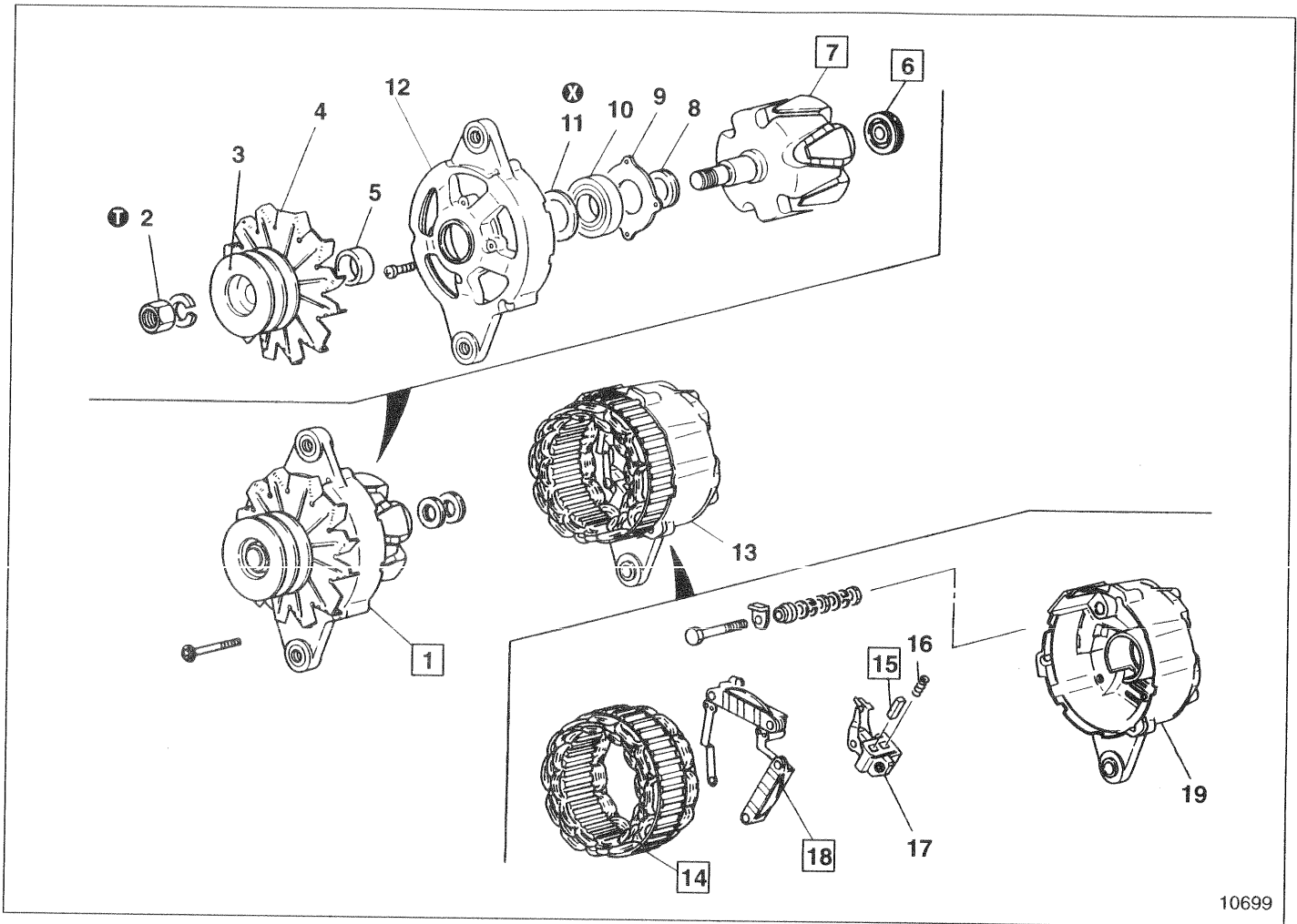

10699

### ● Disassembly sequence

- |                                  |                                   |                             |
|----------------------------------|-----------------------------------|-----------------------------|
| 1 Rotor & front bracket assembly | 9 Cover                           | 16 Brush spring             |
| 2 Nut                            | 10 Front bearing                  | 17 Regulator & brush holder |
| 3 Pulley                         | 11 Oil seal                       | P.54-55                     |
| 4 Fan                            | 12 Front bracket                  | 18 Rectifier                |
| 5 Spacer                         | 13 Stator & rear bracket assembly | 19 Rear bracket             |
| 6 Rear bearing                   | 14 Stator assembly                |                             |
| 7 Rotor assembly                 | 15 Brush                          |                             |
| 8 Cover                          |                                   | ⊗ : Non-reusable part       |

### NOTE

Do not remove parts 6, 10 and 14 unless they are found to be defective.

### ● Reassembly sequence

13 → 1

13: 19 → 18 → 17 → 16 → 15 → 14

1: 12 → 11 → 10 → 9  
7 → 8 → 6 } → 5 → 4 → 3 → 2

## Service standards

Unit: mm

Location	Maintenance item		Standard value	Limit	Remedy
7	Rotor assembly	Field coil resistance (at 20°C)	7.2 Ω	—	Replace
		Slip ring outside diameter	41	40.4	
15	Brush length		23	8	Replace
16	Spring pressure of brush spring		3.1 to 4.3 N {0.32 to 0.44 kgf}	2 N {0.2 kgf}	

## ① Tightening torques

Unit: N·m {kgf·m}

Location	Parts to be tightened	Tightening torque	Remarks
2	Nut (to mount pulley)	132 to 162 {13.5 to 16.5}	—

## ◆ Service procedure

## ① Rotor &amp; front bracket assembly

[Removal]

- Insert a plain screwdriver **A** between the front bracket **12** and stator assembly **14**.
- While wrenching the plain screwdriver **A**, remove the rotor & front bracket assembly **1** from the stator & rear bracket assembly **13**.

**CAUTION** ⚠

If the plain screwdriver **A** is inserted too far, the coil **B** of the stator assembly **14** might be damaged and short-circuited.

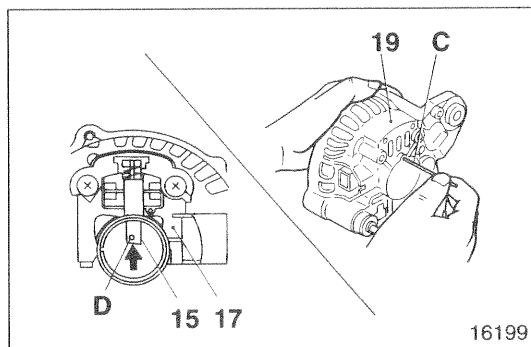
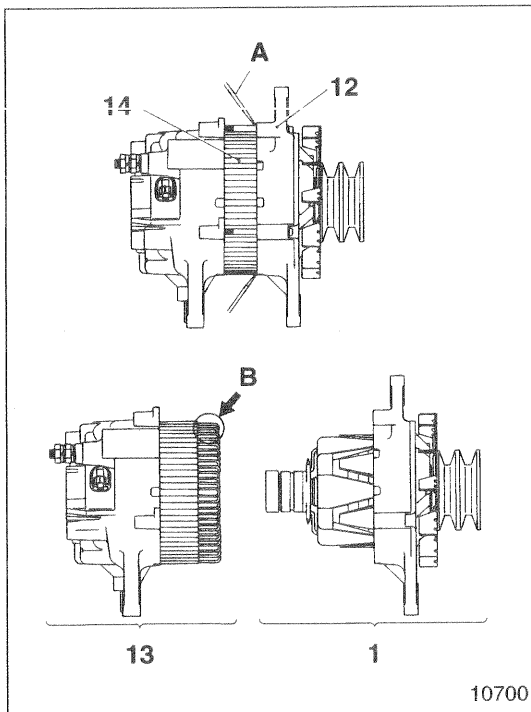

[Installation]

If the brush **15** is protruding from the regulator & brush holder **17**, the rotor assembly **7** cannot be mounted on the rear bracket **19**. Therefore, perform the following steps.

- Push the brush **15** into the regulator & brush holder **17**.
- Insert the pin **C** from the rear of the rear bracket **19** and press the pin **C** against the pin hole **D** to hold the brush **15**.  
If the brush **15** is worn and the pin hole **D** gone, hold the end of the brush **15** with the pin **C**.
- After installation, slowly remove the pin **C**.

# ALTERNATOR <24V-80A (with brush)>

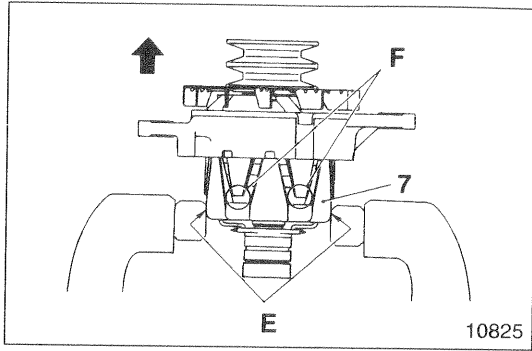

[Disassembly]

## CAUTION

When the rotor assembly 7 is held in a vice, make sure that the base E of the lugs of the core is held.

If the lugs F of the core are held, they will be broken or damaged.

## 6 Removal of rear bearing

### CAUTION

When the bearing puller is installed, use care to prevent damage to the slip ring A.

If the slip ring is damaged, the brush will fail to make good contact.

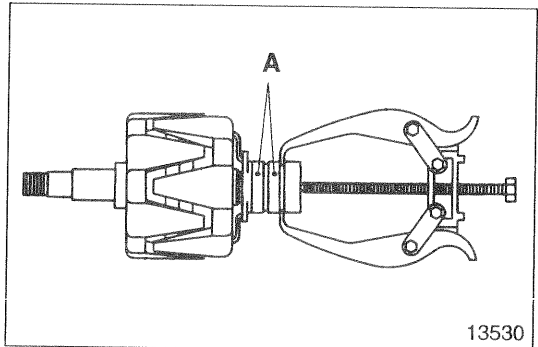

## 7 Inspection of rotor assembly

### (1) Resistance of field coil

- Measure the resistance across the slip ring A.
- If the reading is out of the standard value, replace the rotor assembly 7.

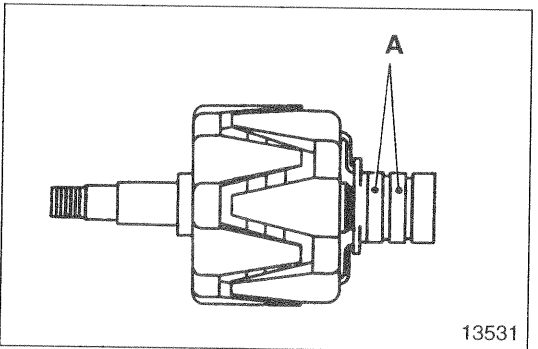

### (2) Continuity between slip ring and core

- Check to ensure that there is no continuity between slip ring A and core B.
- If there is continuity, it means a short circuit. Therefore, replace the rotor assembly 7.

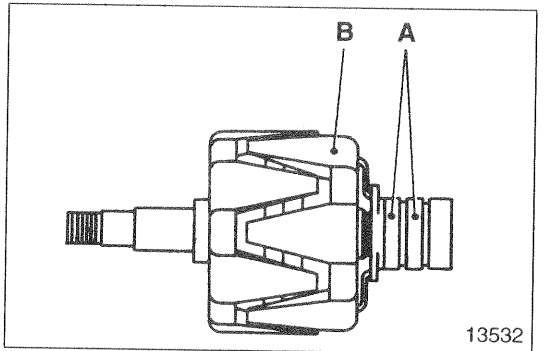

### (3) Outside diameter of slip ring

- If the outside diameter of the slip ring A is below the limit, replace the rotor assembly 7.
- If the outside diameter of the slip ring A is rough or unevenly worn, correct by grinding with emery paper or a lathe.

### CAUTION

Do corrective grinding within the extent that the outside diameter of the slip ring A does not exceed the limit.

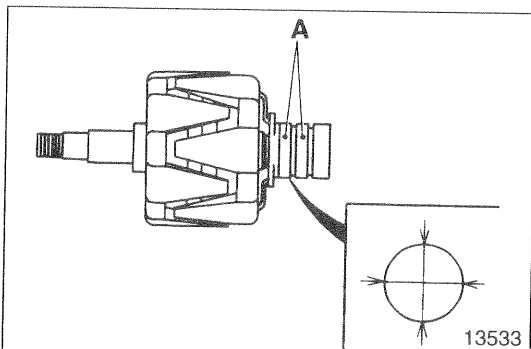

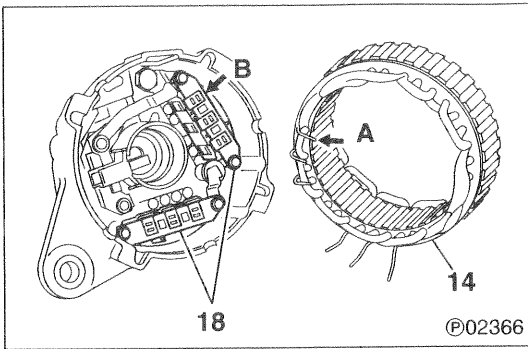

#### 14 Stator assembly

[Removal]

- Disconnect the leads A and remove the stator assembly 14 from the rectifier 18.
- The leads are soldered to the diode leads B of the rectifier. (Six places)

**CAUTION** ⚠

De-soldering should be done quickly (in about 5 seconds or less).  
The diodes will be damaged if heated for a longer time.

- For installation, reverse the order of removal.

[Inspection]

##### (1) Continuity between leads

- Check to ensure that there is continuity between each lead.
- If there is no continuity, the leads are open-circuited. Replace the stator assembly 14.

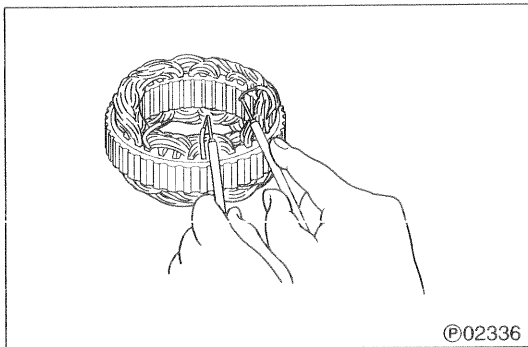

##### (2) Continuity between each lead and core

- Check to ensure that there is no continuity between each lead and the core.
- If there is continuity, it means a short circuit. Replace the stator assembly 14.

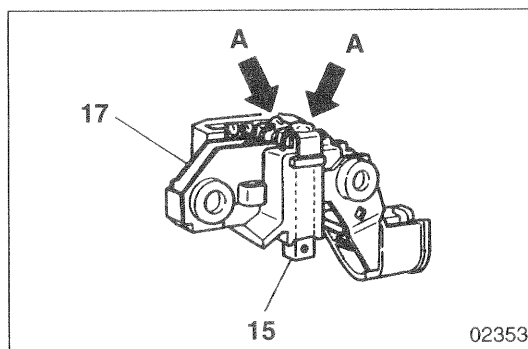
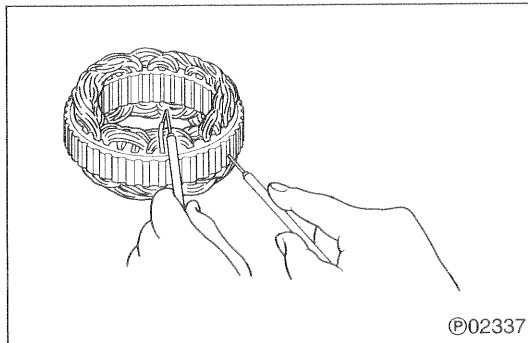

#### 15 Brush

[Removal]

De-solder the illustrated points A and remove the brush 15 from the regulator & brush holder 17.

**CAUTION** ⚠

De-soldering should be done quickly (in about 5 seconds or less).  
The regulator will be damaged if heated for a longer time.

# ALTERNATOR <24V-80A (with brush)>

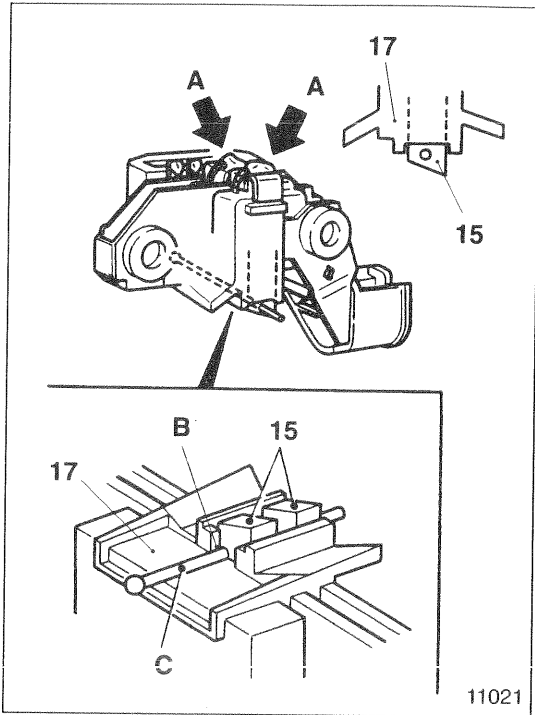

## [Installation]

- Install the brush 15 in the regulator & brush holder 17 in the direction shown.
- Mount the pin C in the hole B of the brush 15 to make sure that the brush does not protrude from the regulator & brush holder 17.
- After installation, solder the leads of the brush 15 to the illustrated points A.

## CAUTION

Soldering should be done quickly (in about 5 seconds or less).  
The regulator will be damaged if heated for a longer time.

- After soldering, remove the pin C.

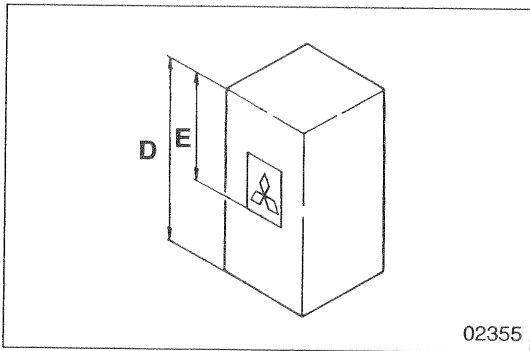

## [Inspection]

If the length of the brush 15 is less than the limit, replace.

- D: Length when new
- E: Service limit length

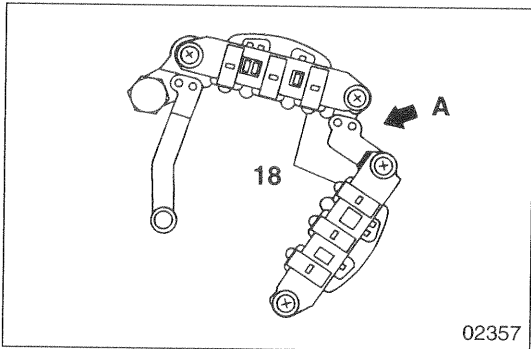

## 18 Rectifier

### [Removal]

- Remove the rectifier 18 by de-soldering the illustrated portion A.

## CAUTION

De-soldering should be done quickly (in about 5 seconds or less).  
The diodes will be damaged if heated for a longer time.

- For installation, reverse the order of removal.

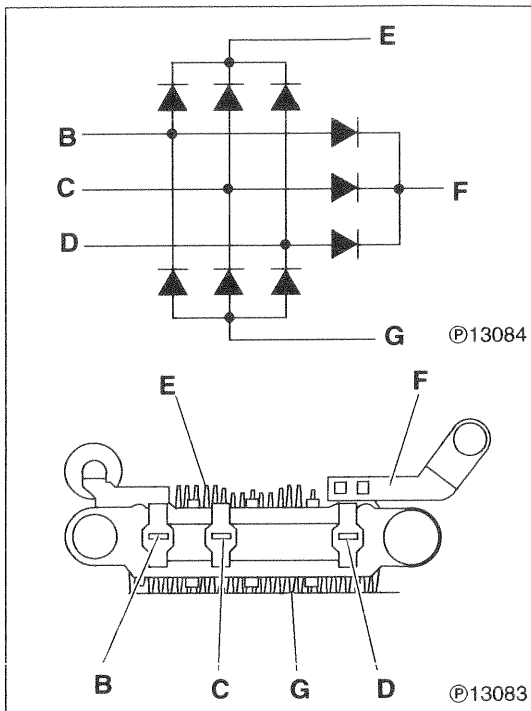

## [Inspection]

- Check the rectifier **18** to see if the internal diodes function properly, and replace if defective.

Resistance infinite in both cases...Open

Resistance close to  $\Omega$  in both cases...Short

**B, C, D:** Leads of stator coil connected

**E, G:** Heat sink portion

**F:** Regulator connected

- Exchange the  $\oplus$  and  $\ominus$  sides of the tester and perform checks in both cases.

**CAUTION** 

When a tester is used for the checks, the current that flows out from the tester is feebler than the current that normally flows through the rectifier **18**, so the tester may indicate a questionable resistance value. In a low range, this tendency will be stronger. Therefore, it is advisable to use the highest possible range.

# ALTERNATOR <12V-60A>

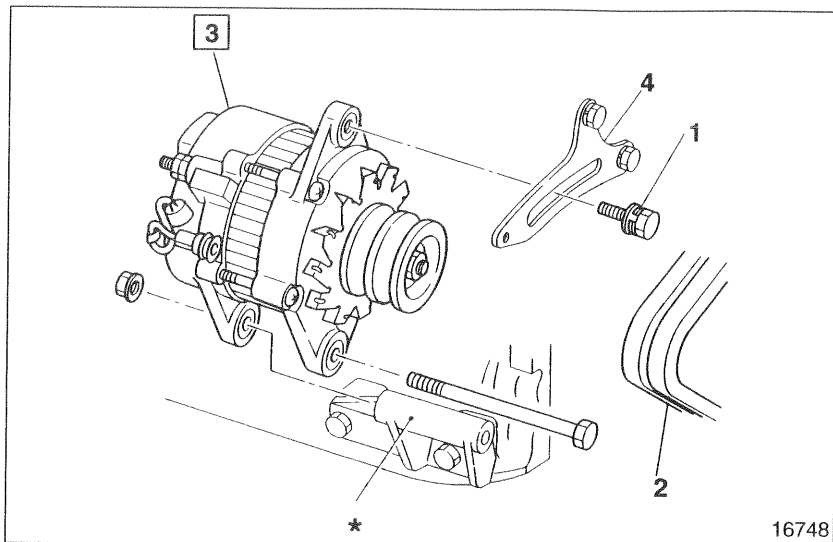

## ● Removal sequence

- 1 Adjust bolt
- 2 V-belt
- 3 Alternator assembly P.54-64
- 4 Adjust plate

\* : Alternator bracket

## WARNING

Before removing the alternator 3, be sure to disconnect the negative  $\ominus$  terminal of the battery and insulate it with a tape or something else. If the negative  $\ominus$  terminal is not disconnected, the battery voltage is always available at terminal B and is dangerous.

## ● Installation sequence

Reverse the order of removal.

## ● Adjustment after installation

Adjust the tension of the V-belt 2. Gr 14

## Service standards

Location	Maintenance item		Standard value	Limit	Remedy	
3	Alternator output current (* When hot, when 27V is generated)	Alternator speed	1500 rpm	26A or more	—	Check
			2500 rpm	45A or more		
			5000 rpm	53A or more		
	Regulator regulated voltage (5000 rpm, loads 5A or less)		14.4 ± 0.3V	—	Replace	

\*: "When hot" refers to the state of the engine after 30 minutes of maximum output operation at 5000 rpm at a normal ambient temperature.

## ◆ Service procedure

### 3 Inspection of alternator

#### (1) Inspection of performance of alternator

(Inspection by test bench)

- Wire the alternator 3 as shown.

#### NOTE

Each wire must be adequately thick and each connection must be properly secured.

A: Ammeter

B: Alternator terminal B

C: Switch

D: Switch

E: Alternator terminal E

F: Load resistance (variable resistance)

G: Alternator drive motor

R: Alternator terminal R

V: Voltmeter

- Increase the load resistance F to a maximum (where practically no load current flows).
- Set the switch C and switch D to ON.
- Operate the alternator 3 at 5000 rpm for 30 minutes with the load resistance F adjusted such that the output current is as specified in "Service standard".

Nominal value of alternator current

12V-60A

- Measure the current with the alternator 3 at each of the specified speeds.
- If the reading is out of the standard value, disassemble and check the alternator 3. P.54-64

#### (2) Inspection of performance of regulator

(Inspection by test bench)

- Wire the alternator 3 as shown.

A: Ammeter

B: Alternator terminal B

C: Switch

E: Alternator terminal E

G: Alternator drive motor

L: Alternator terminal L

R: Alternator terminal R

V: Voltmeter

- Set the switch C to ON.
- Let the alternator 3 rotate at a low speed.
- Increase the rotating speed of the alternator 3 to 5000 rpm and measure the voltage (regulated voltage). At the same time, check to ensure that the current value is 5A or less.
- If the readings are out of the standard values, proceed as described below.
  - If the readings exceed the standard values, replace the regulator.
  - If the readings are below the standard values, check all the parts of the alternator before replacing the regulator.

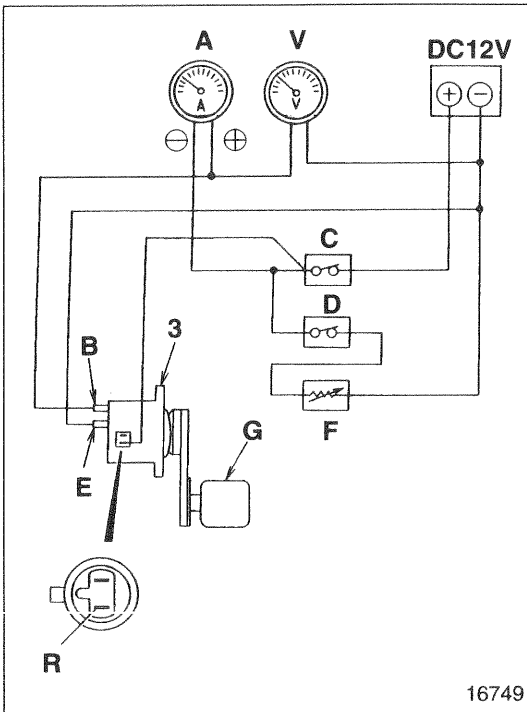

16749

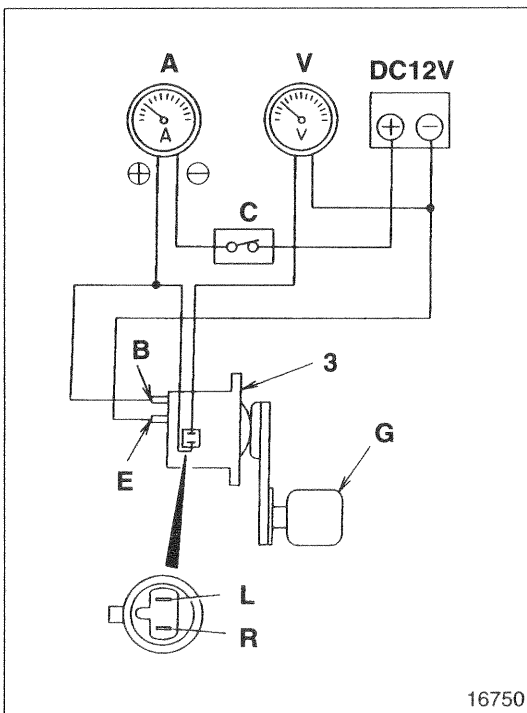

16750

# ALTERNATOR <12V-60A>

## Alternator Assembly

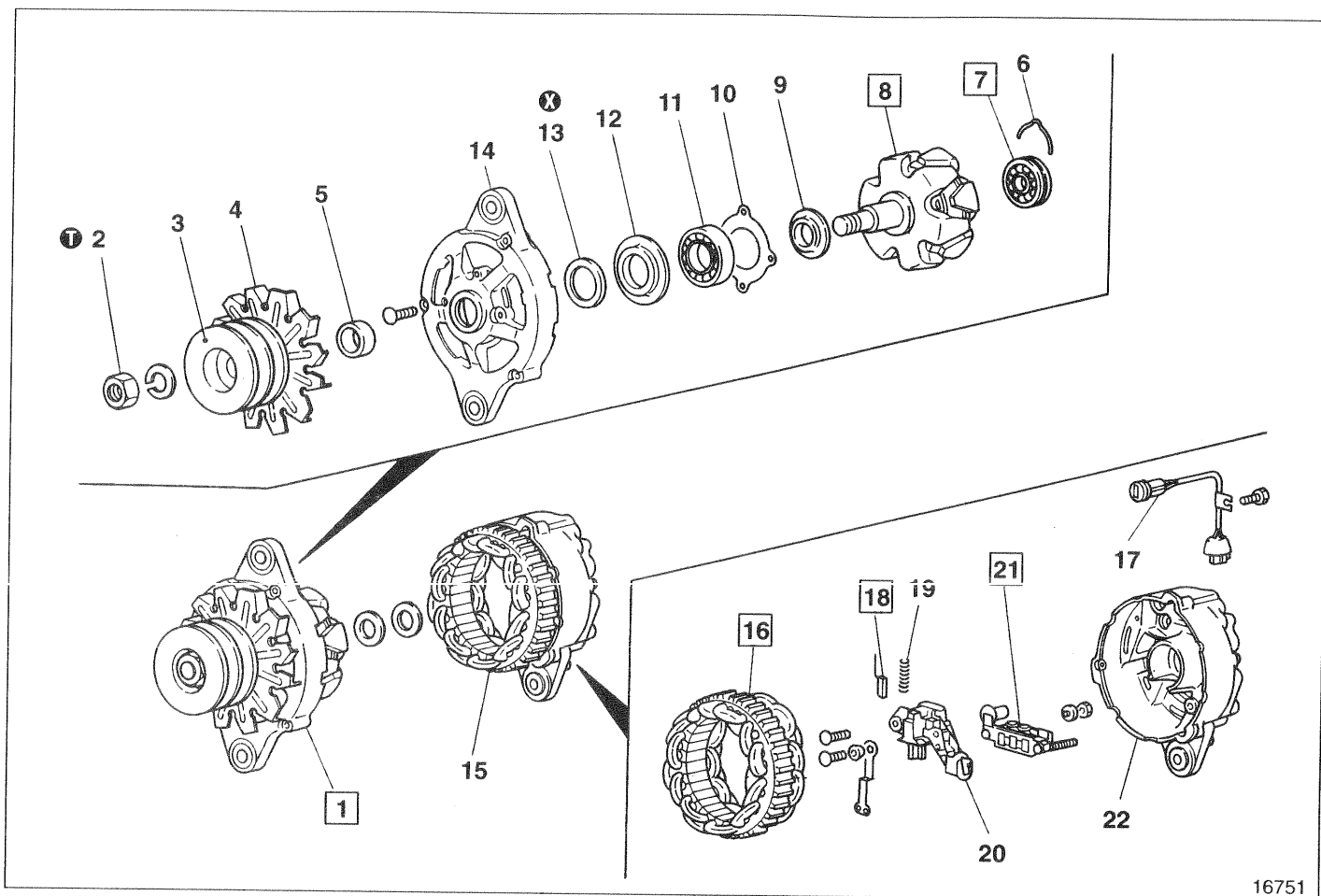

16751

### ● Disassembly sequence

- |                                  |                                   |                             |
|----------------------------------|-----------------------------------|-----------------------------|
| 1 Rotor & front bracket assembly | 10 Cover                          | 18 Brush                    |
| 2 Nut                            | 11 Front bearing                  | 19 Brush spring             |
| 3 Pulley                         | 12 Cover                          | 20 Regulator & brush holder |
| 4 Fan                            | 13 Oil seal                       | P.54-63                     |
| 5 Spacer                         | 14 Front bracket                  | 21 Rectifier                |
| 6 Spring                         | 15 Stator & rear bracket assembly | 22 Rear bracket             |
| 7 Rear bearing                   | 16 Stator assembly                |                             |
| 8 Rotor assembly                 | 17 Connector                      |                             |
| 9 Cover                          |                                   |                             |

ⓧ : Non-reusable part

### NOTE

Do not remove parts 7, 11 and 16 unless they are found to be defective.

### ● Reassembly sequence

15 → 1

15: 

20 → 19 → 18	} → 22 → 17
21 → 16	

1: 

14 → 13 → 12 → 11 → 10	} → 5 → 4 → 3 → 2
8 → 7 → 9 → 6	

## Service standards

Unit: mm

Location	Maintenance item	Standard value	Limit	Remedy	
8	Rotor assembly	Field coil resistance (at 20°C)	2.4 Ω	—	Replace
		Slip ring outside diameter	40.8 to 41.2	40.4	
18	Brush length	23	8	Replace	
19	Spring pressure of brush spring	3.1 to 4.3 N {0.32 to 0.44 kgf}	2 N {0.2 kgf}	Replace	

## ① Tightening torques

Unit: N·m {kgf·m}

Location	Parts to be tightened	Tightening torque	Remarks
2	Nut (to mount pulley)	132 to 162 {13.5 to 16.5}	—

## ◆ Service procedure

## ① Rotor &amp; front bracket assembly

[Removal]

- Insert a plain screwdriver **A** between the front bracket **14** and stator assembly **16**.
- While wrenching the plain screwdriver **A**, remove the rotor & front bracket assembly **1** from the stator & rear bracket assembly **15**.

**CAUTION** ⚠

If the plain screwdriver **A** is inserted too far, the coil **B** of the stator assembly **16** might be damaged and short-circuited.

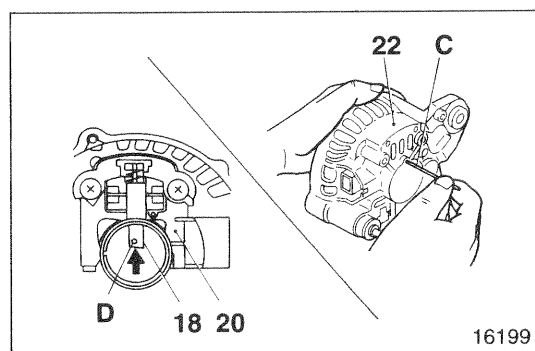
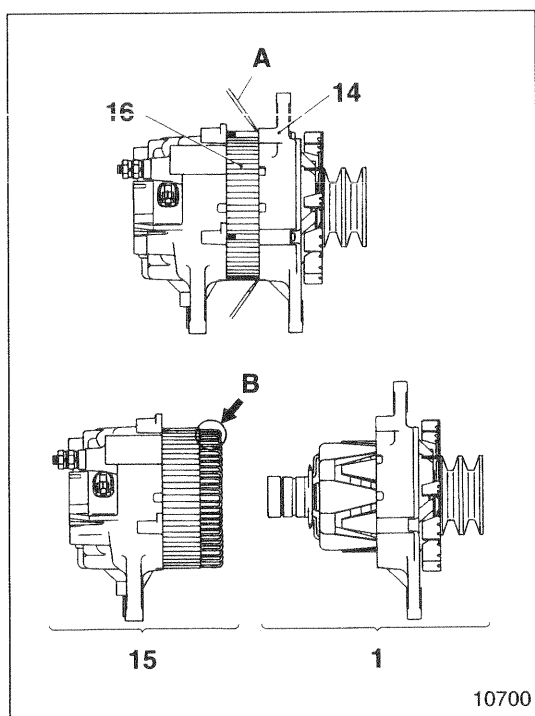

[Installation]

If the brush **18** is protruding from the regulator & brush holder **20**, the rotor assembly **8** cannot be mounted on the rear bracket **22**. Therefore, perform the following steps.

- Push the brush **18** into the regulator & brush holder **20**.
- Insert the pin **C** from the rear of the rear bracket **22** and press the pin **C** against the pin hole **D** to hold the brush **18**.  
If the brush **18** is worn and the pin hole **D** gone, hold the end of the brush **18** with the pin **C**.
- After installation, slowly remove the pin **C**.

# ALTERNATOR <12V-60A>

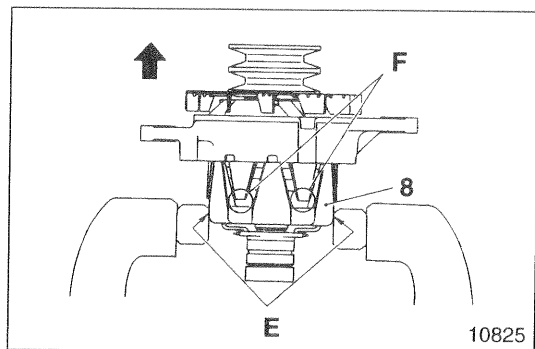

[Disassembly]

## CAUTION

When the rotor assembly 8 is held in a vice, make sure that the base E of the lugs of the core is held.

If the lugs F of the core are held, they will be broken or damaged.

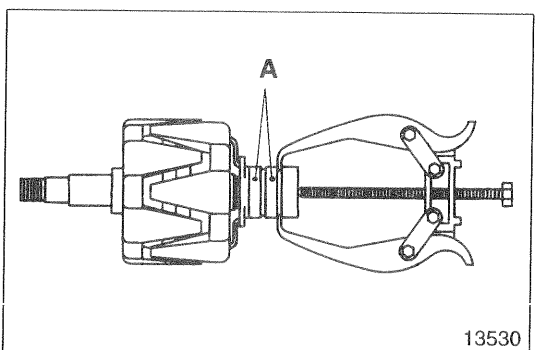

## 7 Removal of rear bearing

### CAUTION

When the bearing puller is installed, use care to prevent damage to the slip ring A.

If the slip ring is damaged, the brush will fail to make good contact.

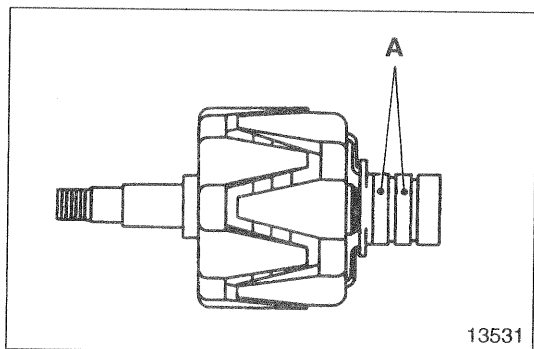

## 8 Inspection of rotor assembly

### (1) Resistance of field coil

- Measure the resistance across the slip ring A.
- If the reading is out of the standard value, replace the rotor assembly 8.

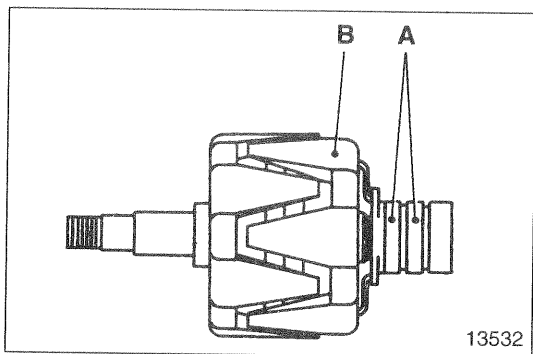

### (2) Continuity between slip ring and core

- Check to ensure that there is no continuity between slip ring A and core B.
- If there is continuity, it means a short circuit. Therefore, replace the rotor assembly 8.

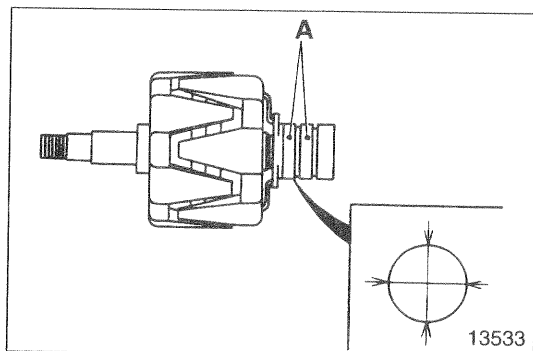

### (3) Outside diameter of slip ring

- If the outside diameter of the slip ring A is below the limit, replace the rotor assembly 8.
- If the outside diameter of the slip ring A is rough or unevenly worn, correct by grinding with emery paper or a lathe.

### CAUTION

Do corrective grinding within the extent that the outside diameter of the slip ring A does not exceed the limit.

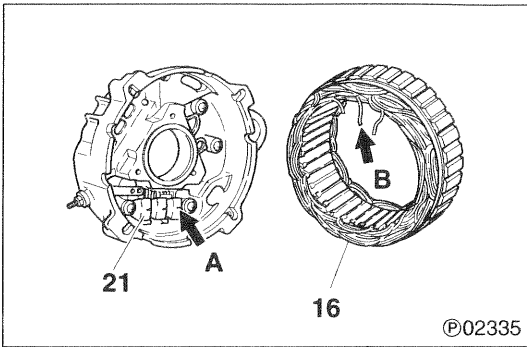

## 16 Stator assembly

[Removal]

- Disconnect the leads **A** and remove the stator assembly **16** from the rectifier **21**.

The leads are soldered to the diode leads **B** of the rectifier. (Six places)

### CAUTION

De-soldering should be done quickly (in about 5 seconds or less).  
The diodes will be damaged if heated for a longer time.

- For installation, reverse the order of removal.

[Inspection]

### (1) Continuity between leads

- Check to ensure that there is continuity between each lead.
- If there is no continuity, the leads are open-circuited. Replace the stator assembly **16**.

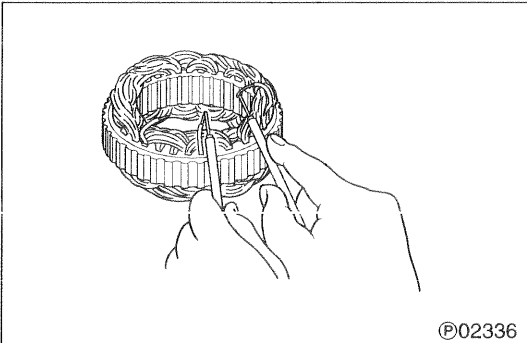

### (2) Continuity between each lead and core

- Check to ensure that there is no continuity between each lead and the core.
- If there is continuity, it means a short circuit. Replace the stator assembly **16**.

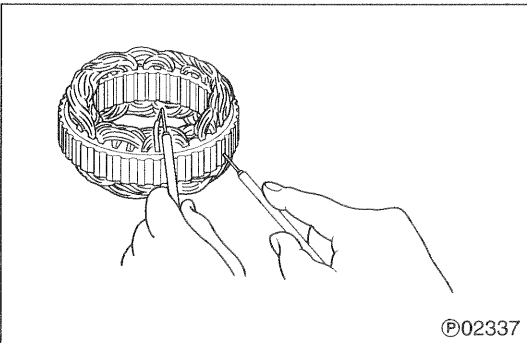

## 18 Brush

[Removal]

De-solder the illustrated points **A** and remove the brush **18** from the regulator & brush holder **20**.

### CAUTION

De-soldering should be done quickly (in about 5 seconds or less).  
The regulator will be damaged if heated for a longer time.

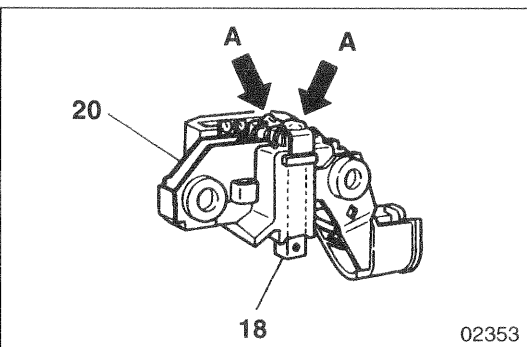

# ALTERNATOR <12V-60A>

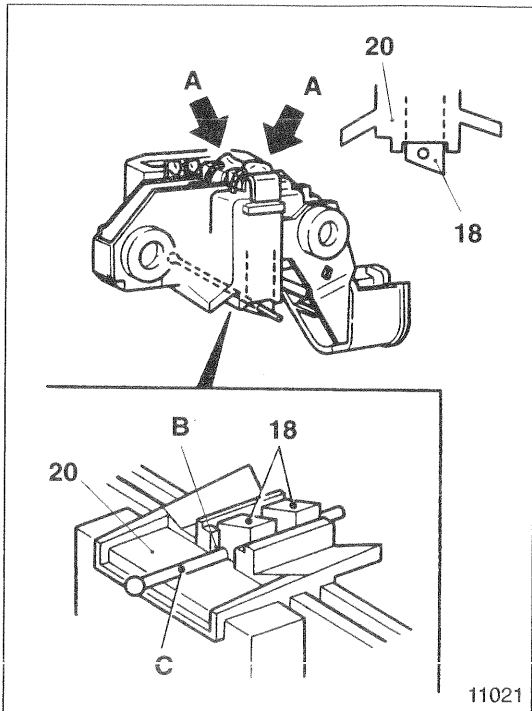

11021

## [Installation]

- Install the brush 18 in the regulator & brush holder 20 in the direction shown.
- Mount the pin C in the hole B of the brush 18 to make sure that the brush does not protrude from the regulator & brush holder 20.
- After installation, solder the leads of the brush 18 to the illustrated points A.

## CAUTION

Soldering should be done quickly (in about 5 seconds or less).  
The regulator will be damaged if heated for a longer time.

- After soldering, remove the pin C.

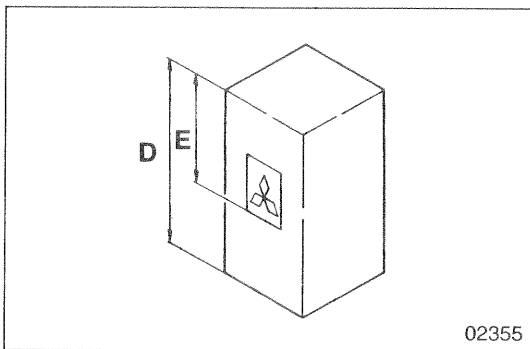

02355

## [Inspection]

If the length of the brush 18 is less than the limit, replace.

- D: Length when new
- E: Service limit length

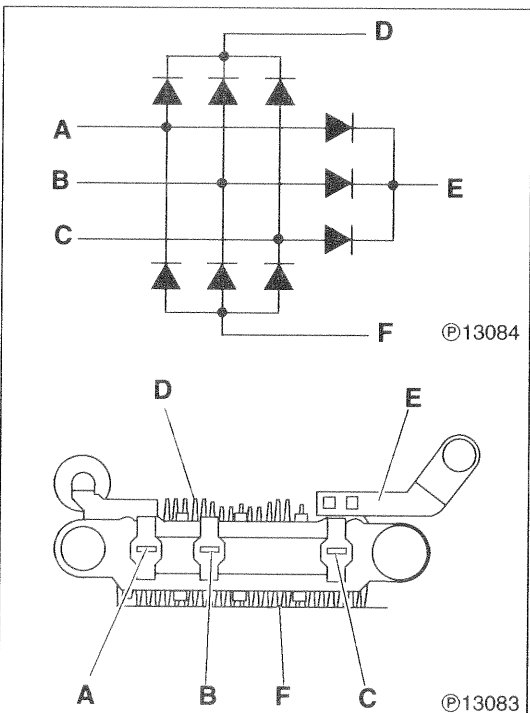

©13084

©13083

## 21 Inspection of rectifier

- Check the rectifier 21 to see if the internal diodes function properly, and replace if defective.

Resistance infinite in both cases....Open  
Resistance close to  $\Omega$  in both cases...Short

- A, B, C: Leads of stator coil connected
- D, F: Heat sink portion
- E: Regulator connected

- Exchange the  $\oplus$  and  $\ominus$  sides of the tester and perform checks in both cases.

## CAUTION

When a tester is used for the checks, the current that flows out from the tester is feebler than the current that normally flows through the rectifier 21, so the tester may indicate a questionable resistance value. In a low range, this tendency will be stronger. Therefore, it is advisable to use the highest possible range.

---

**M E M O**

---

# ALTERNATOR <24V-40A (with vacuum pump)>

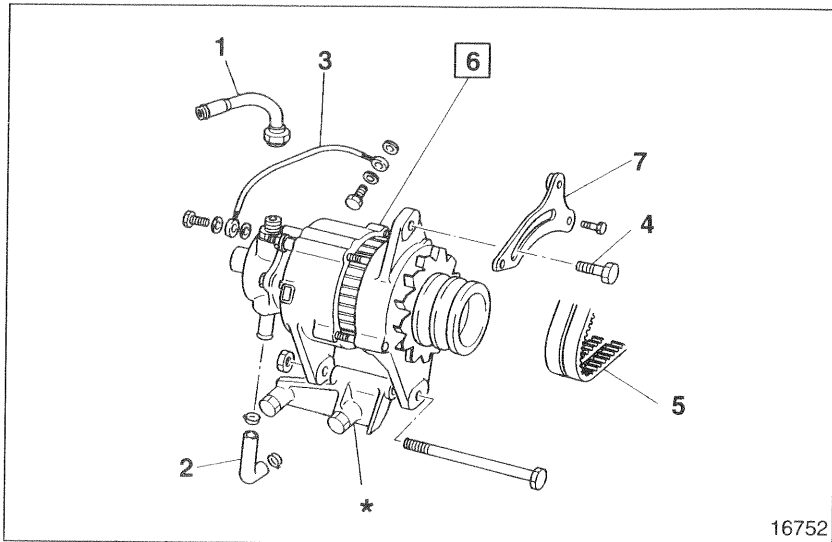

## ● Removal sequence

- 1 Vacuum pipe
- 2 Oil return hose
- 3 Oil inlet hose
- 4 Adjust plate
- 5 V-belt
- 6 Alternator assembly P.54-72
- 7 Adjust plate

\* : Alternator bracket

## WARNING

Before removing the alternator 6, be sure to disconnect the negative  $\ominus$  terminal of the battery and insulate it with a tape or something else. If the negative  $\ominus$  terminal is not disconnected, the battery voltage is always available at terminal B and is dangerous.

## ● Installation sequence

Reverse the order of removal.

## ● Adjustment after installation

Adjust the tension of the V-belt 5. Gr 14

## Service standards

Location	Maintenance item		Standard value	Limit	Remedy
6	Alternator output current (* When hot, when 27V is generated)	Alternator speed	1500 rpm	24A or more	Check
			2500 rpm	33A or more	
			5000 rpm	37A or more	
	Regulator regulated voltage (5000 rpm, loads 5A or less)		28.5 ± 0.5V	—	Replace

\*: "When hot" refers to the state of the engine after 30 minutes of maximum output operation at 5000 rpm at a normal ambient temperature.

## ◆ Service procedure

### 6 Inspection of alternator

#### (1) Inspection of performance of alternator

(Inspection by test bench)

- Wire the alternator 6 as shown.

#### NOTE

Each wire must be adequately thick and each connection must be properly secured.

A: Ammeter

B: Alternator terminal B

C: Switch

D: Switch

E: Alternator terminal E

F: Load resistance (variable resistance)

G: Alternator drive motor

L: Alternator terminal L

R: Alternator terminal R

V: Voltmeter

- Increase the load resistance F to a maximum (where practically no load current flows).

- Set the switch C and switch D to ON.

- Operate the alternator 6 at 5000 rpm for 30 minutes with the load resistance F adjusted such that the output current is as specified in "Service standard".

Nominal value of alternator current

24V-40A

- Measure the current with the alternator 6 at each of the specified speeds.

- If the reading is out of the standard value, disassemble and check the alternator 6. P.54-72

#### (2) Inspection of performance of regulator

(Inspection by test bench)

- Wire the alternator 6 as shown.

A: Ammeter

B: Alternator terminal B

C: Switch

E: Alternator terminal E

G: Alternator drive motor

L: Alternator terminal L

R: Alternator terminal R

V: Voltmeter

- Set the switch C to ON.

- Let the alternator 6 rotate at a low speed.

- Increase the rotating speed of the alternator 6 to 5000 rpm and measure the voltage (regulated voltage). At the same time, check to ensure that the current value is 5A or less.

- If the readings are out of the standard values, proceed as described below.

- If the readings exceed the standard values, replace the regulator.

- If the readings are below the standard values, check all the parts of the alternator before replacing the regulator.

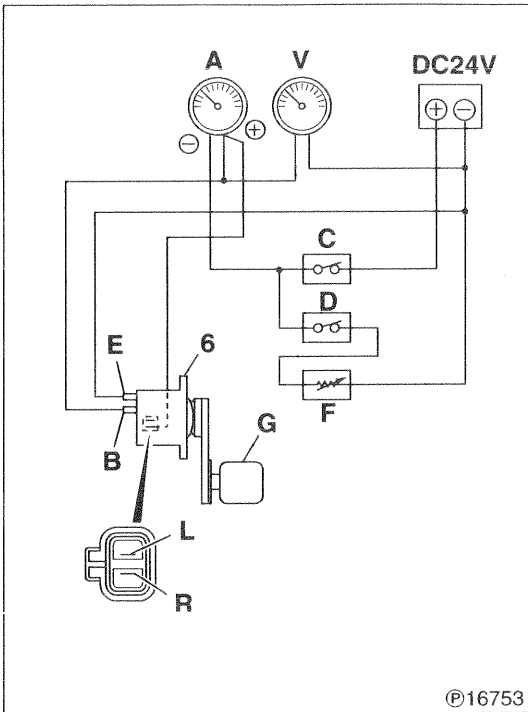

©16753

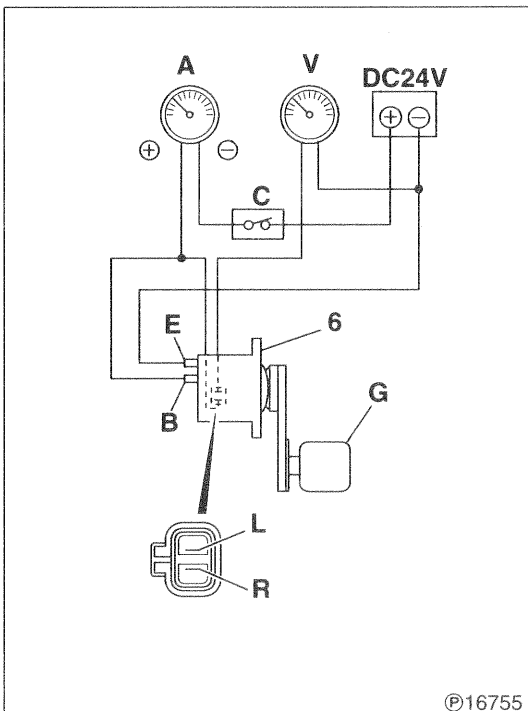

©16755

# ALTERNATOR <24V-40A (with vacuum pump)>

## Alternator Assembly

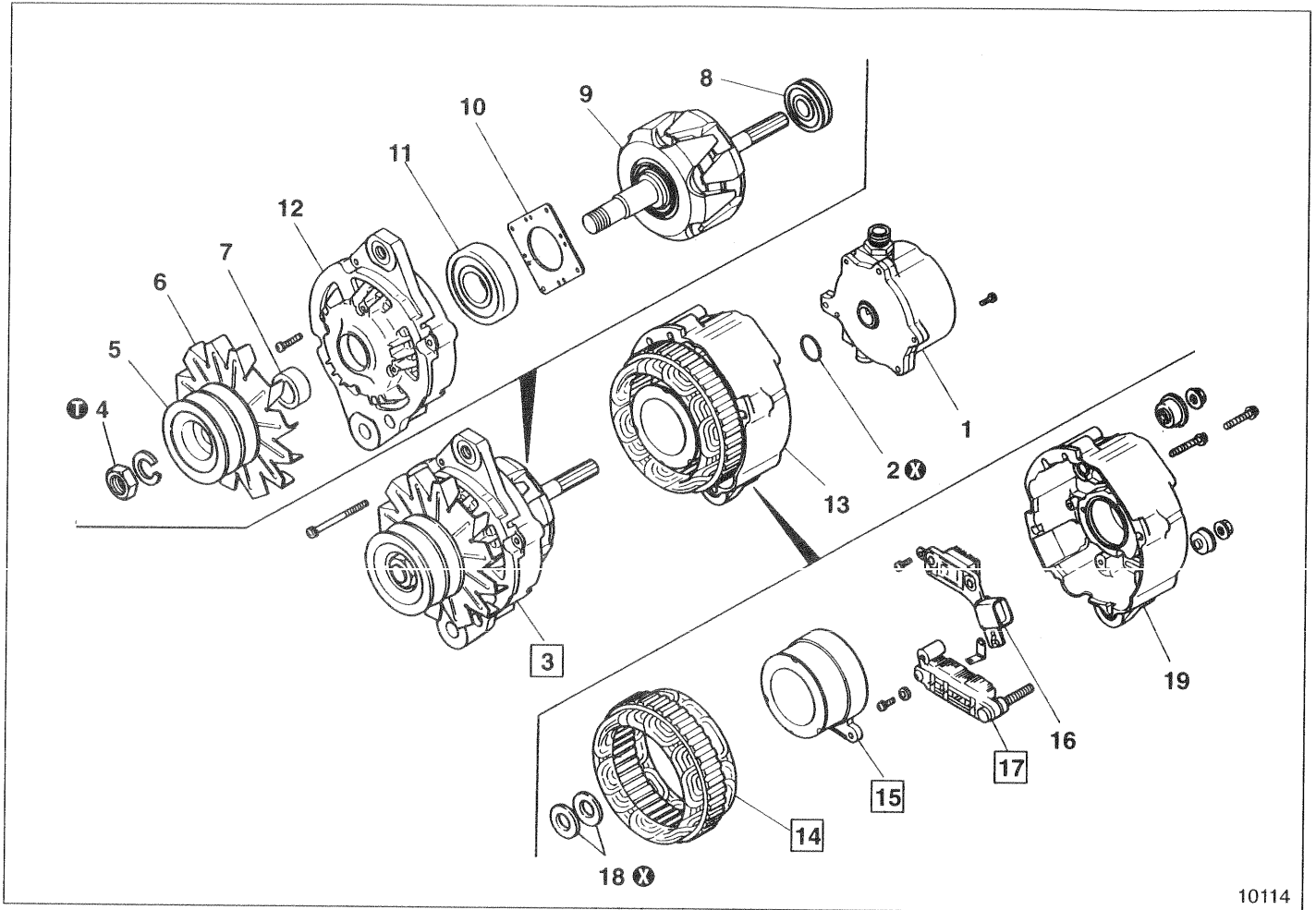

10114

### Disassembly sequence

- |                                   |                                   |                      |
|-----------------------------------|-----------------------------------|----------------------|
| 1 Vacuum pump assembly<br>P.54-76 | 8 Rear bearing                    | 15 Field coil        |
| 2 O-ring                          | 9 Rotor assembly                  | 16 Regulator P.54-71 |
| 3 Rotor & front bracket assembly  | 10 Cover                          | 17 Rectifier         |
| 4 Nut                             | 11 Front bearing                  | 18 Oil seal          |
| 5 Pulley                          | 12 Front bracket                  | 19 Rear bracket      |
| 6 Fan                             | 13 Stator & rear bracket assembly |                      |
| 7 Spacer                          | 14 Stator assembly                |                      |
- ⓧ : Non-reusable part

### NOTE

Do not remove parts 8, 11 and 14 unless they are found to be defective.

### Reassembly sequence

13 → 3 → 2 → 1

13: 19 → 18 → 16 → 17 → 15 → 14

3: 12 → 11 → 10 → 9 → 8 → 7 → 6 → 5 → 4

## Service standards

Location	Maintenance item	Standard value	Limit	Remedy
15	Field coil resistance (at 20°C)	Approx. 6.2 Ω	—	Replace

## ⓘ Tightening torques

Unit: N · m {kgf · m}

Location	Parts to be tightened	Tightening torque	Remarks
4	Nut (to mount pulley)	132 to 162 {13.5 to 16.5}	—

## ◆ Service procedure

### 3 Rotor & front bracket assembly

[Removal]

#### CAUTION

Wind a tape around the spline portion **A** of the shaft of the rotor & front bracket assembly **3** to prevent damage to the oil seal **18** at the time of removal.

- Insert a plain screwdriver **A** between the front bracket **12** and stator assembly **14**.
- While wrenching the plain screwdriver **A**, remove the rotor & front bracket assembly **3** from the stator & rear bracket assembly **13**.

#### CAUTION

If the plain screwdriver **A** is inserted too far, the coil **B** of the stator assembly **14** might be damaged and short-circuited.

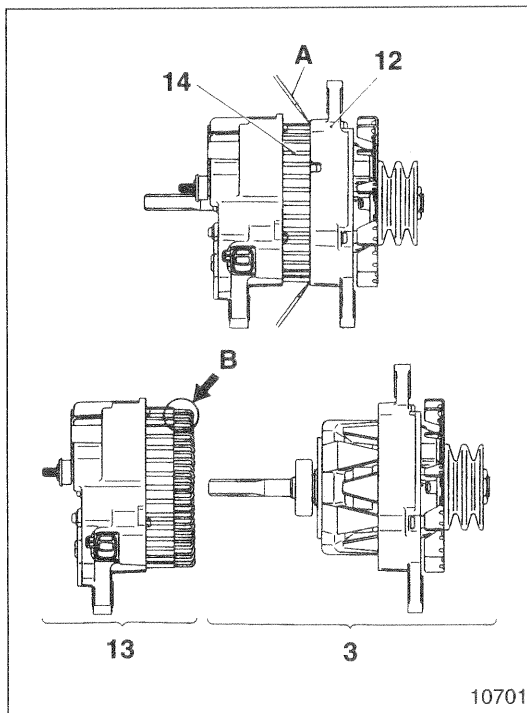
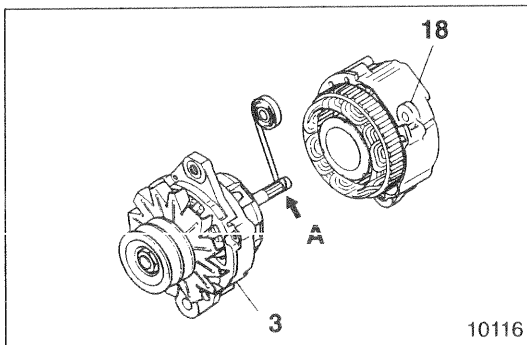

# ALTERNATOR <24V-40A (with vacuum pump)>

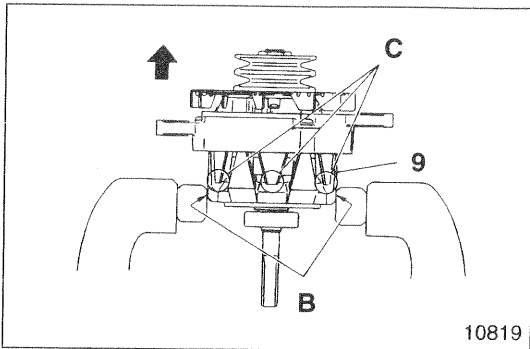

[Disassembly]

## CAUTION

When the rotor assembly 9 is held in a vice, make sure that the base B of the lugs of the core is held.

If the lugs C of the core are held, they will be broken or damaged.

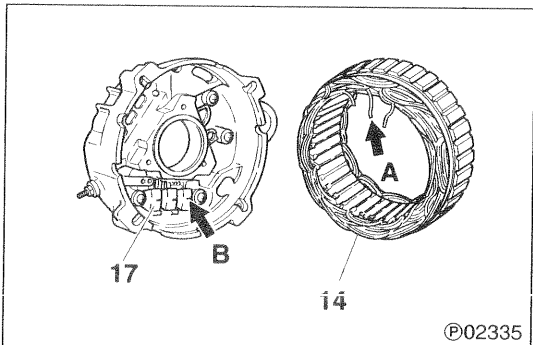

## 14 Stator assembly

[Removal]

- Disconnect the leads A and remove the stator assembly 14 from the rectifier 17.

The leads are soldered to the diode leads B of the rectifier. (Three places)

## CAUTION

De-soldering should be done quickly (in about 5 seconds or less). The diodes will be damaged if heated for a longer time.

- For installation, reverse the order of removal.

[Inspection]

### (1) Continuity between leads

- Check to ensure that there is continuity between each lead.
- If there is no continuity, the leads are open-circuited. Replace the stator assembly 14.

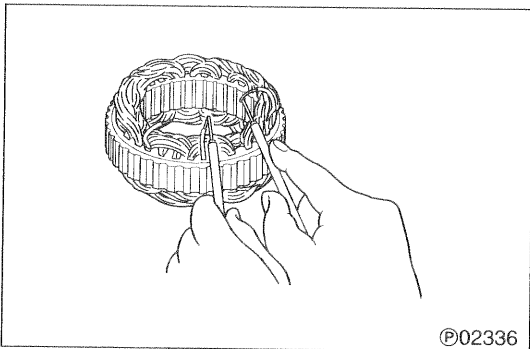

### (2) Continuity between each lead and core

- Check to ensure that there is no continuity between each lead and the core.
- If there is continuity, it means a short circuit. Replace the stator assembly 14.

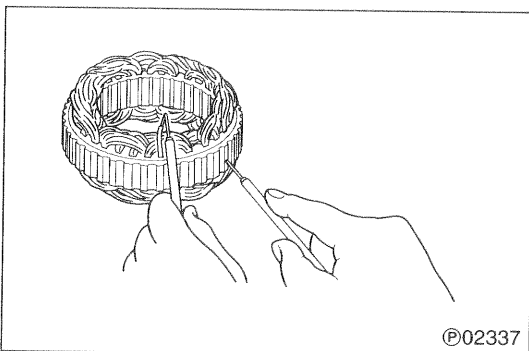

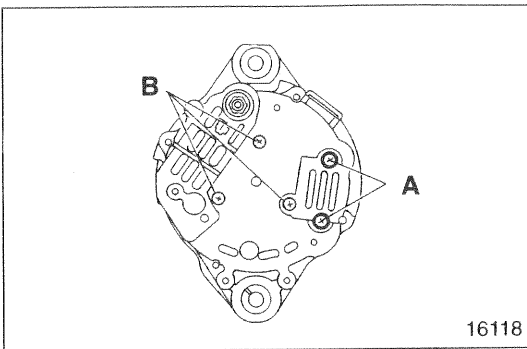

**15** Field coil

[Removal]

- Remove the two screws A.

**CAUTION** ⚠

If the screws B are removed first, the weight of the field coil 15 will act on the lead portion secured by the screws A, and damage to the lead portion may result. Therefore, make sure that the screws A are removed first.

- Remove the three screws B.

**CAUTION** ⚠

When the screws B are removed, the field coil 15 will fall under its own weight. Therefore, hold the field coil by hand beforehand.

- Remove the field coil 15.

**CAUTION** ⚠

When the field coil 15 is taken out, the coil lead portion may be caught by the stator coil. Don't pull it out with undue force.

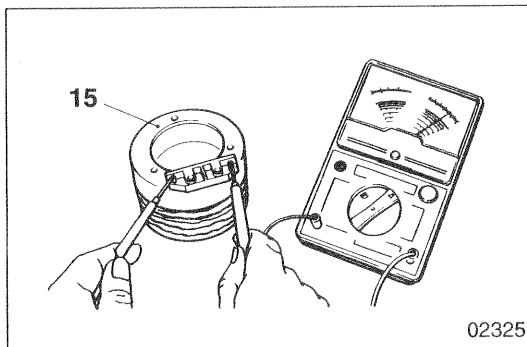

[Inspection]

- Measure the resistance between the terminals of the field coil 15.
- If the reading is out of the standard value, replace the field coil 15.

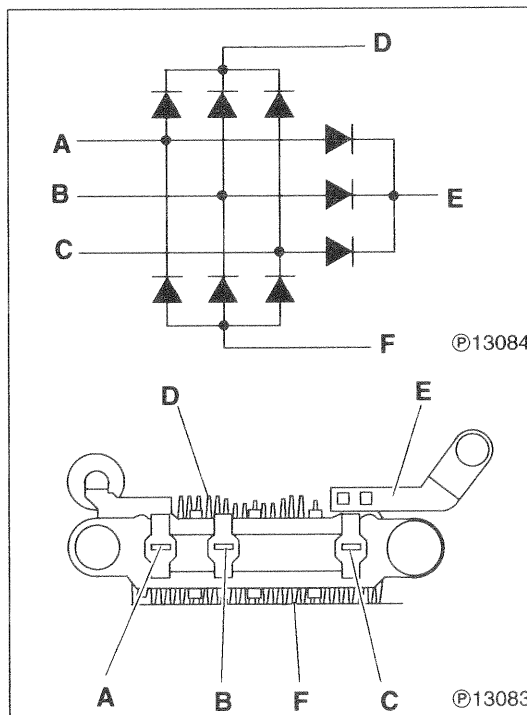

**17** Inspection of rectifier

- Check the rectifier 17 to see if the internal diodes function properly, and replace if defective.

Resistance infinite in both cases...Open  
Resistance close to  $\Omega$  in both cases...Short

A, B, C: Leads of stator coil connected  
D, F: Heat sink portion  
E: Regulator connected

- Exchange the  $\oplus$  and  $\ominus$  sides of the tester and perform checks in both cases.

**CAUTION** ⚠

When a tester is used for the checks, the current that flows out from the tester is feebler than the current that normally flows through the rectifier 17, so the tester may indicate a questionable resistance value. In a low range, this tendency will be stronger. Therefore, it is advisable to use the highest possible range.

# ALTERNATOR <24V-40A (with vacuum pump)>

## Vacuum Pump Assembly

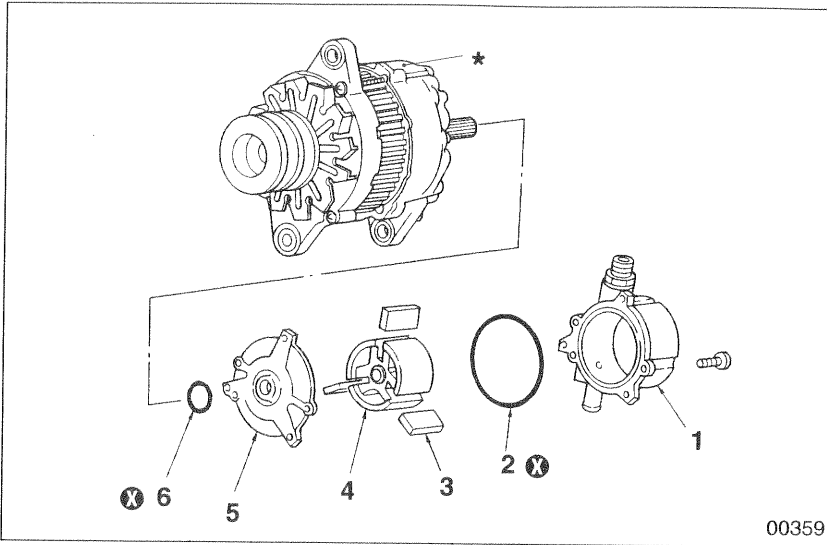

### ● Disassembly sequence

- 1 Vacuum housing
- 2 O-ring
- 3 Vane
- 4 Rotor
- 5 Plate
- 6 O-ring

\*: Alternator P.54-72

⊗: Non-reusable part

### ● Reassembly sequence

Reverse the order of removal.

## Service standards

Location	Maintenance item	Standard value	Limit	Remedy
—	Attainable vacuum pressure (when alternator speed is 1500 rpm)	93 kPa {700 mmHg or more}	—	—

---

**M E M O**

---

# ALTERNATOR <24V-40A (without vacuum pump)>

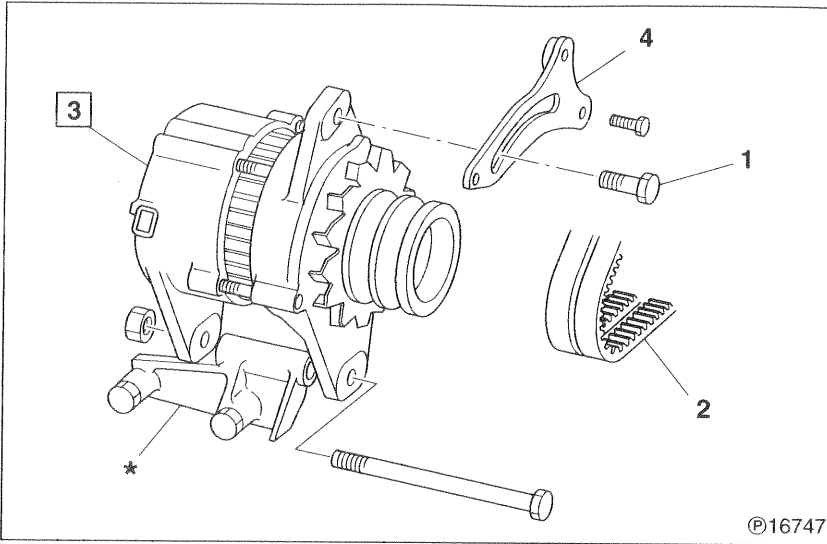

## ● Removal sequence

- 1 Adjust bolt
- 2 V-belt
- 3 Alternator assembly P.54-80
- 4 Adjust plate

\* : Alternator bracket

## WARNING

Before removing the alternator 3, be sure to disconnect the negative  $\ominus$  terminal of the battery and insulate it with a tape or something else. If the negative  $\ominus$  terminal is not disconnected, the battery voltage is always available at terminal B and is dangerous.

## ● Installation sequence

Reverse the order of removal.

## ● Adjustment after installation

Adjust the tension of the V-belt 2. Gr 14

## Service standards

Location	Maintenance item		Standard value	Limit	Remedy	
3	Alternator output current (* When hot, when 27V is generated)	Alternator speed	1500 rpm	24A or more	—	Check
			2500 rpm	33A or more		
			5000 rpm	37A or more		
	Regulator regulated voltage (5000 rpm, loads 5A or less)		28.5 ± 0.5V	—	Replace	

\*: "When hot" refers to the state of the engine after 30 minutes of maximum output operation at 5000 rpm at a normal ambient temperature.

## ◆ Service procedure

### 3 Inspection of alternator

#### (1) Inspection of performance of alternator

(Inspection by test bench)

- Wire the alternator 3 as shown.

#### NOTE

Each wire must be adequately thick and each connection must be properly secured.

A: Ammeter

B: Alternator terminal B

C: Switch

D: Switch

E: Alternator terminal E

F: Load resistance (variable resistance)

G: Alternator drive motor

L: Alternator terminal L

R: Alternator terminal R

V: Voltmeter

- Increase the load resistance F to a maximum (where practically no load current flows).
- Set the switch C and switch D to ON.
- Operate the alternator 3 at 5000 rpm for 30 minutes with the load resistance F adjusted such that the output current is as specified in "Service standard".

Nominal value of alternator current

24V-40A

- Measure the current with the alternator 3 at each of the specified speeds.
- If the reading is out of the standard value, disassemble and check the alternator 3. P.54-80

#### (2) Inspection of performance of regulator

(Inspection by test bench)

- Wire the alternator 3 as shown.

A: Ammeter

B: Alternator terminal B

C: Switch

E: Alternator terminal E

G: Alternator drive motor

L: Alternator terminal L

R: Alternator terminal R

V: Voltmeter

- Set the switch C to ON.
- Let the alternator 3 rotate at a low speed.
- Increase the rotating speed of the alternator 3 to 5000 rpm and measure the voltage (regulated voltage). At the same time, check to ensure that the current value is 5A or less.
- If the readings are out of the standard values, proceed as described below.
  - If the readings exceed the standard values, replace the regulator.
  - If the readings are below the standard values, check all the parts of the alternator before replacing the regulator.

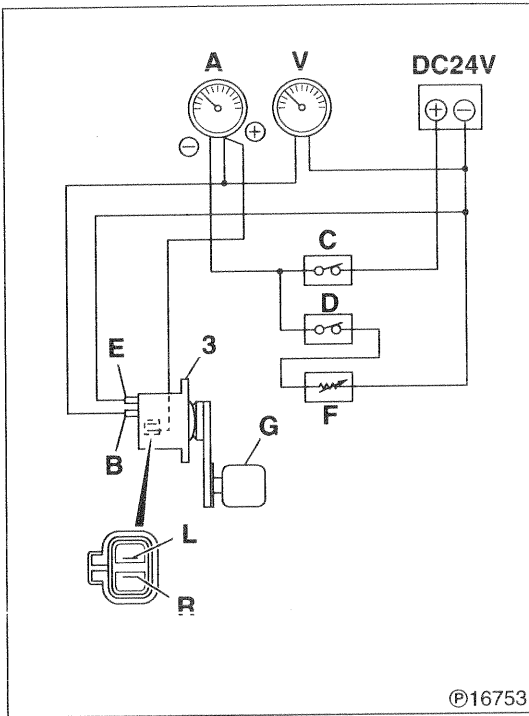

©16753

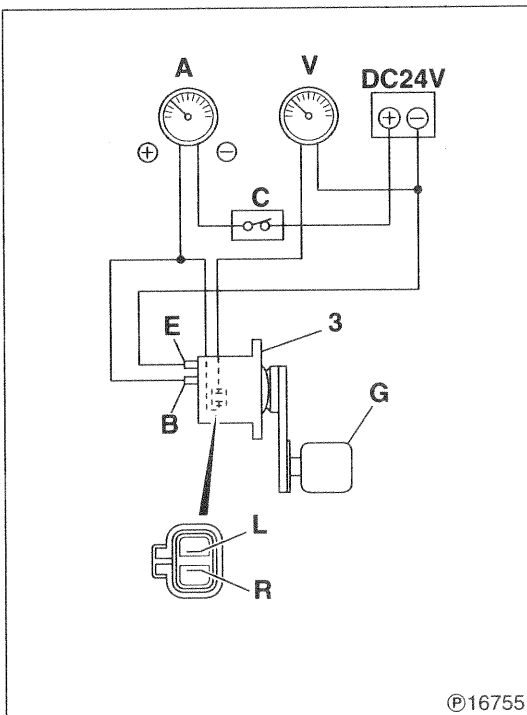

©16755

# ALTERNATOR <24V-40A (without vacuum pump)>

## Alternator Assembly

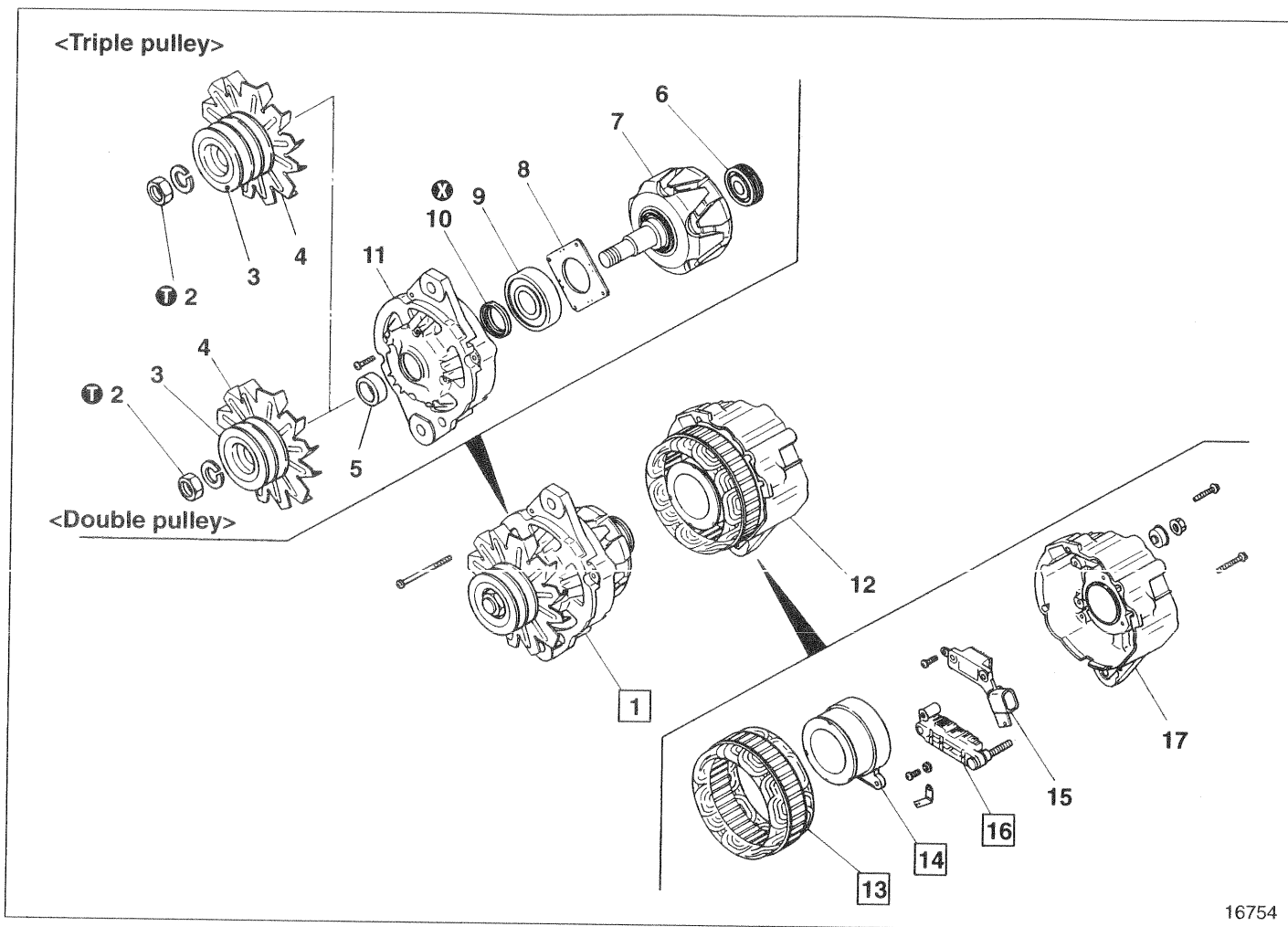

16754

### ● Disassembly sequence

- |                                  |                                   |                       |
|----------------------------------|-----------------------------------|-----------------------|
| 1 Rotor & front bracket assembly | 8 Cover                           | 14 Field coil         |
| 2 Nut                            | 9 Front bearing                   | 15 Regulator  P.54-79 |
| 3 Pulley                         | 10 Oil seal                       | 16 Rectifier          |
| 4 Fan                            | 11 Front bracket                  | 17 Rear bracket       |
| 5 Spacer                         | 12 Stator & rear bracket assembly |                       |
| 6 Rear bearing                   | 13 Stator assembly                | ⓧ: Non-reusable part  |
| 7 Rotor assembly                 |                                   |                       |

### NOTE

Do not remove parts 6, 9 and 13 unless they are found to be defective.

### ● Reassembly sequence

12 → 1

12: 

17 → 16	→	14 → 13
15		

1: 

11 → 10 → 9 → 8	→	5 → 4 → 3 → 2
7 → 6		

## Service standards

Location	Maintenance item	Standard value	Limit	Remedy
14	Field coil resistance (at 20°C)	5.8 to 6.6 $\Omega$	—	Replace

## ⓘ Tightening torques

Unit: N · m {kgf · m}

Location	Parts to be tightened	Tightening torque	Remarks
2	Nut (to mount pulley)	132 to 162 {13.5 to 16.5}	—

## ◆ Service procedure

### 1 Rotor & front bracket assembly

[Removal]

- Insert a plain screwdriver **A** between the front bracket **11** and stator assembly **13**.
- While wrenching the plain screwdriver **A**, remove the rotor & front bracket assembly **1** from the stator & rear bracket assembly **12**.

### CAUTION

If the plain screwdriver **A** is inserted too far, the coil **B** of the stator assembly **13** might be damaged and short-circuited.

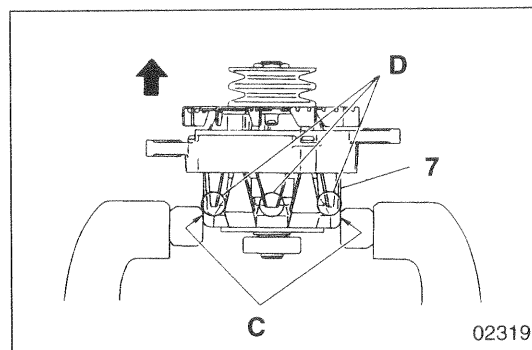
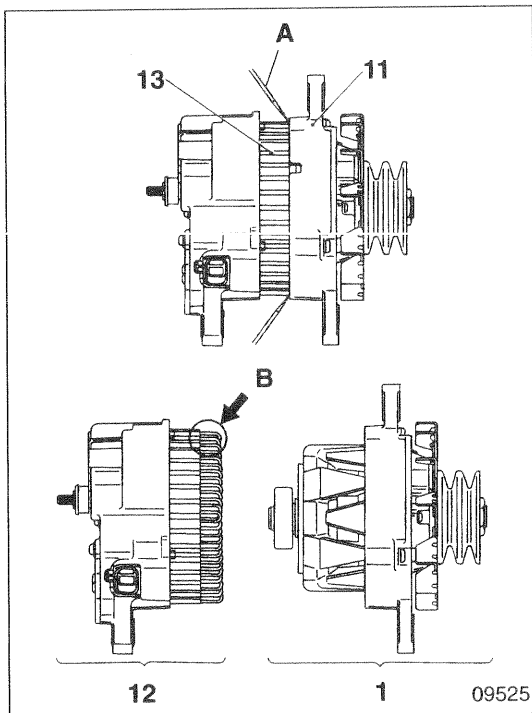

[Disassembly]

### CAUTION

When the rotor assembly **7** is held in a vice, make sure that the base **C** of the lugs of the core is held.

If the lugs **D** of the core are held, they will be broken or damaged.

# ALTERNATOR <24V-40A (without vacuum pump)>

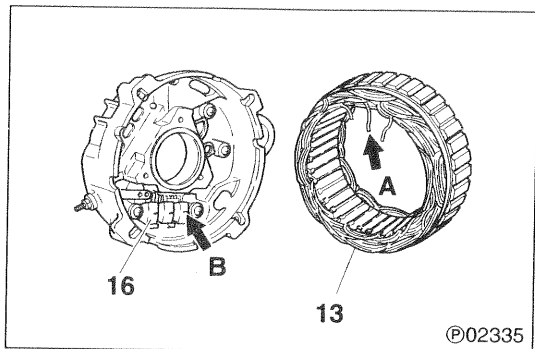

## 13 Stator assembly

[Removal]

- Disconnect the leads **A** and remove the stator assembly **13** from the rectifier **16**.  
The leads are soldered to the diode leads **B** of the rectifier. (Three places)

### CAUTION

De-soldering should be done quickly (in about 5 seconds or less).  
The diodes will be damaged if heated for a longer time.

- For installation, reverse the order of removal.

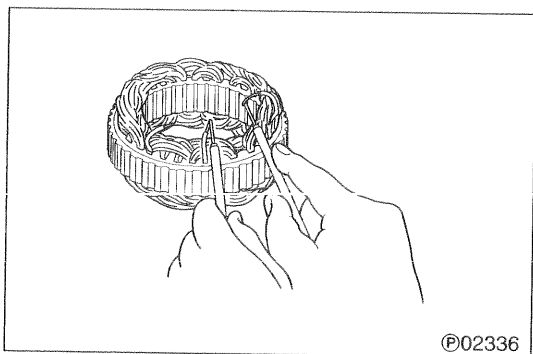

[Inspection]

### (1) Continuity between leads

- Check to ensure that there is continuity between each lead.
- If there is no continuity, the leads are open-circuited. Replace the stator assembly **13**.

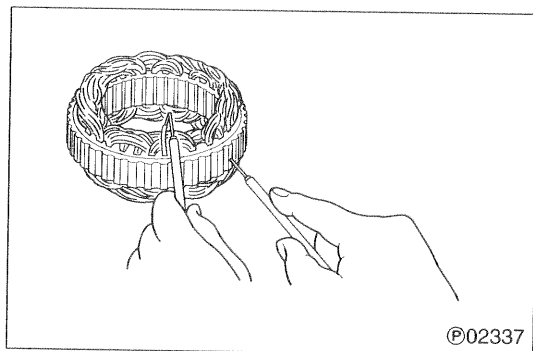

### (2) Continuity between each lead and core

- Check to ensure that there is no continuity between each lead and the core.
- If there is continuity, it means a short circuit. Replace the stator assembly **13**.

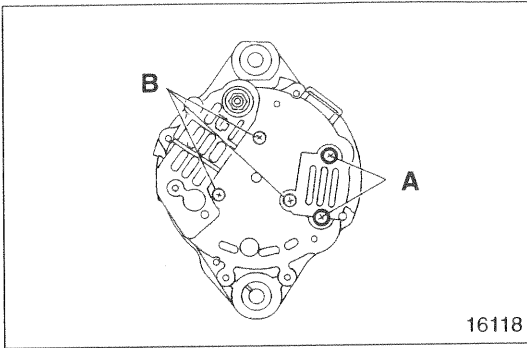

**14** Field coil

[Removal]

- Remove the two screws A.

**CAUTION** ⚠

If the screws B are removed first, the weight of the field coil 14 will act on the lead portion secured by the screws A, and damage to the lead portion may result. Therefore, make sure that the screws A are removed first.

- Remove the three screws B.

**CAUTION** ⚠

When the screws B are removed, the field coil will fall under its own weight. Therefore, hold the field coil by hand beforehand.

- Remove the field coil 14.

**CAUTION** ⚠

When the field coil is taken out, the coil lead portion may be caught by the stator coil. Don't pull it out with undue force.

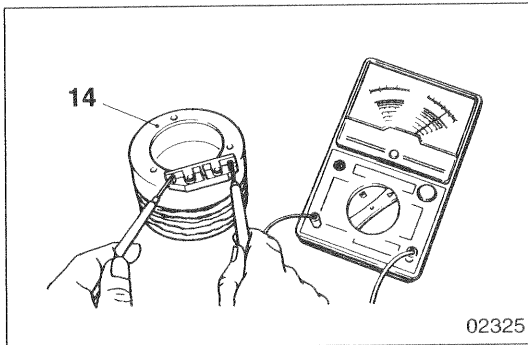

[Inspection]

- Measure the resistance between terminals of the field coil 14.
- If the reading is out of the standard value, replace the field coil 14.

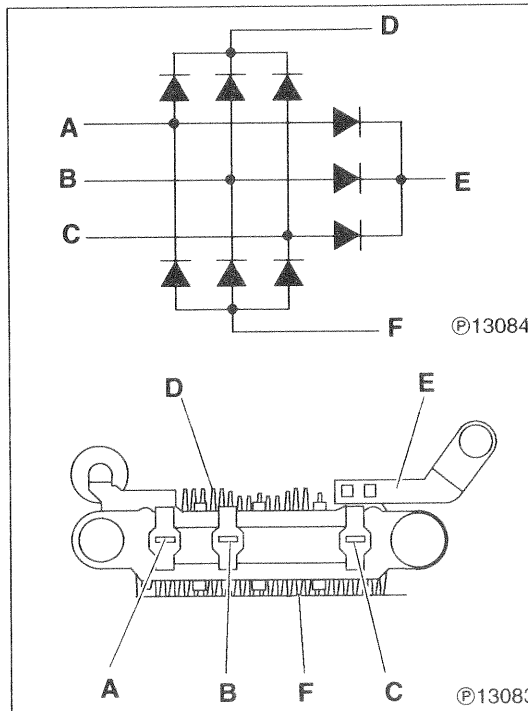

**16** Inspection of rectifier

- Check the rectifier 16 to see if the internal diodes function properly, and replace if defective.

Resistance infinite in both cases...Open  
Resistance close to  $\Omega$  in both cases...Short

A, B, C: Leads of stator coil connected  
D, F: Heat sink portion  
E: Regulator connected

- Exchange the  $\oplus$  and  $\ominus$  sides of the tester and perform checks in both cases.

**CAUTION** ⚠

When a tester is used for the checks, the current that flows out from the tester is feebler than the current that normally flows through the rectifier 16, so the tester may indicate a questionable resistance value. In a low range, this tendency will be stronger. Therefore, it is advisable to use the highest possible range.

# ALTERNATOR <24V-50A>

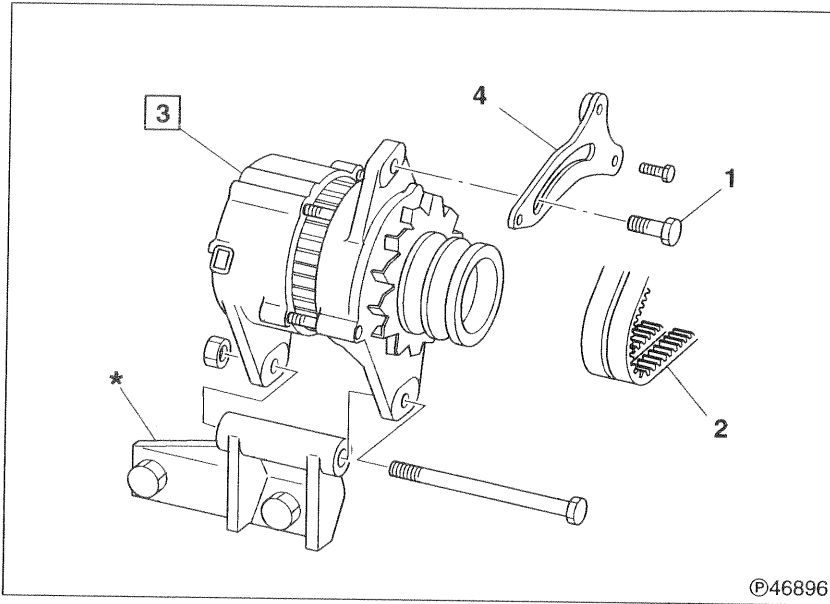

## ● Removal sequence

- 1 Adjust bolt
- 2 V-belt
- 3 Alternator assembly P.54-86
- 4 Adjust plate

\*: Alternator bracket

## WARNING

Before removing the alternator 3, be sure to disconnect the negative  $\ominus$  terminal of the battery and insulate it with a tape or something else. If the negative  $\ominus$  terminal is not disconnected, the battery voltage is always available at terminal B and is dangerous.

## ● Installation sequence

Reverse the order of removal.

## ● Adjustment after installation

Adjust the tension of the V-belt 2. Gr 14

## Service standards

Location	Maintenance item		Standard value	Limit	Remedy	
3	Alternator output current (* When hot, when 27V is generated)	Alternator speed	1500 rpm	24A or more	—	Check
			2500 rpm	38A or more		
			5000 rpm	45A or more		
	Regulator regulated voltage (5000 rpm, loads 5A or less)			28.5 ± 0.5V	—	Replace

\*: "When hot" refers to the state of the engine after 30 minutes of maximum output operation at 5000 rpm at a normal ambient temperature.

## ◆ Service procedure

### 3 Inspection of alternator

#### (1) Inspection of performance of alternator (Inspection by test bench)

- Wire the alternator 3 as shown.

#### NOTE

Each wire must be adequately thick and each connection must be properly secured.

- A: Ammeter
- B: Alternator terminal B
- C: Switch
- D: Switch
- E: Alternator terminal E
- F: Load resistance (variable resistance)
- G: Alternator drive motor
- L: Alternator terminal L
- R: Alternator terminal R
- V: Voltmeter

- Increase the load resistance F to a maximum (where practically no load current flows).
- Set the switch C and switch D to ON.
- Operate the alternator 3 at 5000 rpm for 30 minutes with the load resistance F adjusted such that the output current is as specified in "Service standard".

Nominal value of alternator current

24V-50A

- Measure the current with the alternator 3 at each of the specified speeds.
- If the reading is out of the standard value, disassemble and check the alternator 3.  P.54-86

#### (2) Inspection of performance of regulator

(Inspection by test bench)

- Wire the alternator 3 as shown.

- A: Ammeter
- B: Alternator terminal B
- C: Switch
- E: Alternator terminal E
- G: Alternator drive motor
- L: Alternator terminal L
- R: Alternator terminal R
- V: Voltmeter

- Set the switch C to ON.
- Let the alternator 3 rotate at a low speed.
- Increase the rotating speed of the alternator 3 to 5000 rpm and measure the voltage (regulated voltage). At the same time, check to ensure that the current value is 5A or less.
- If the readings are out of the standard values, proceed as described below.
  - If the readings exceed the standard values, replace the regulator.
  - If the readings are below the standard values, check all the parts of the alternator before replacing the regulator.

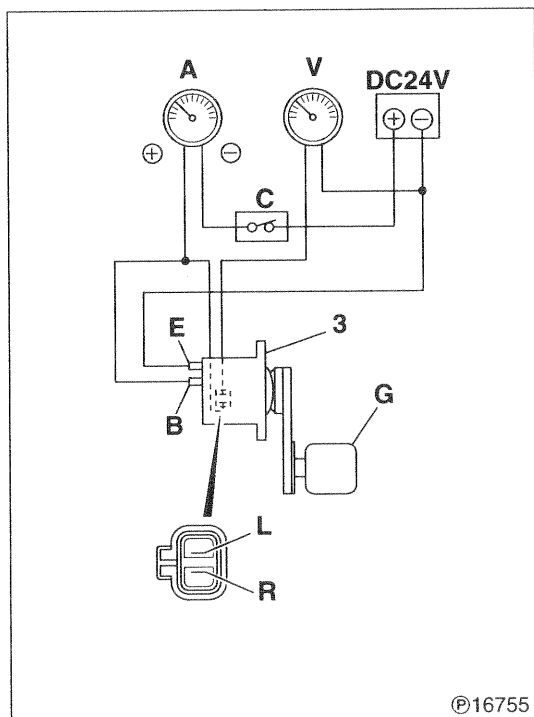
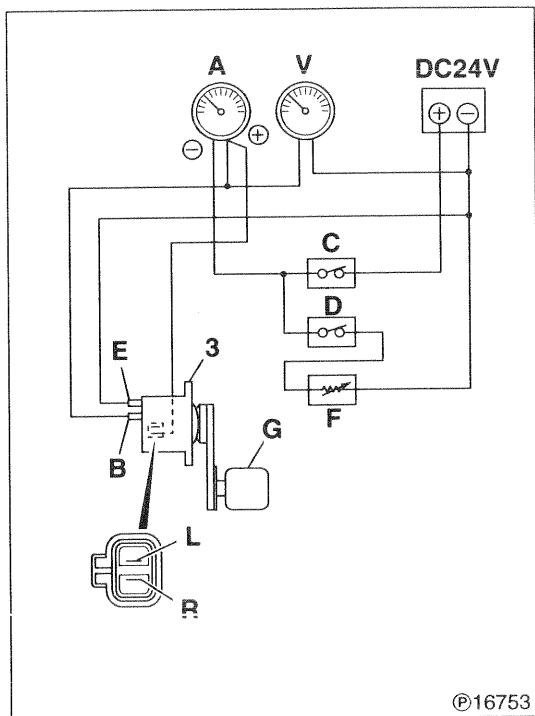

# ALTERNATOR <24V-50A>

## Alternator Assembly

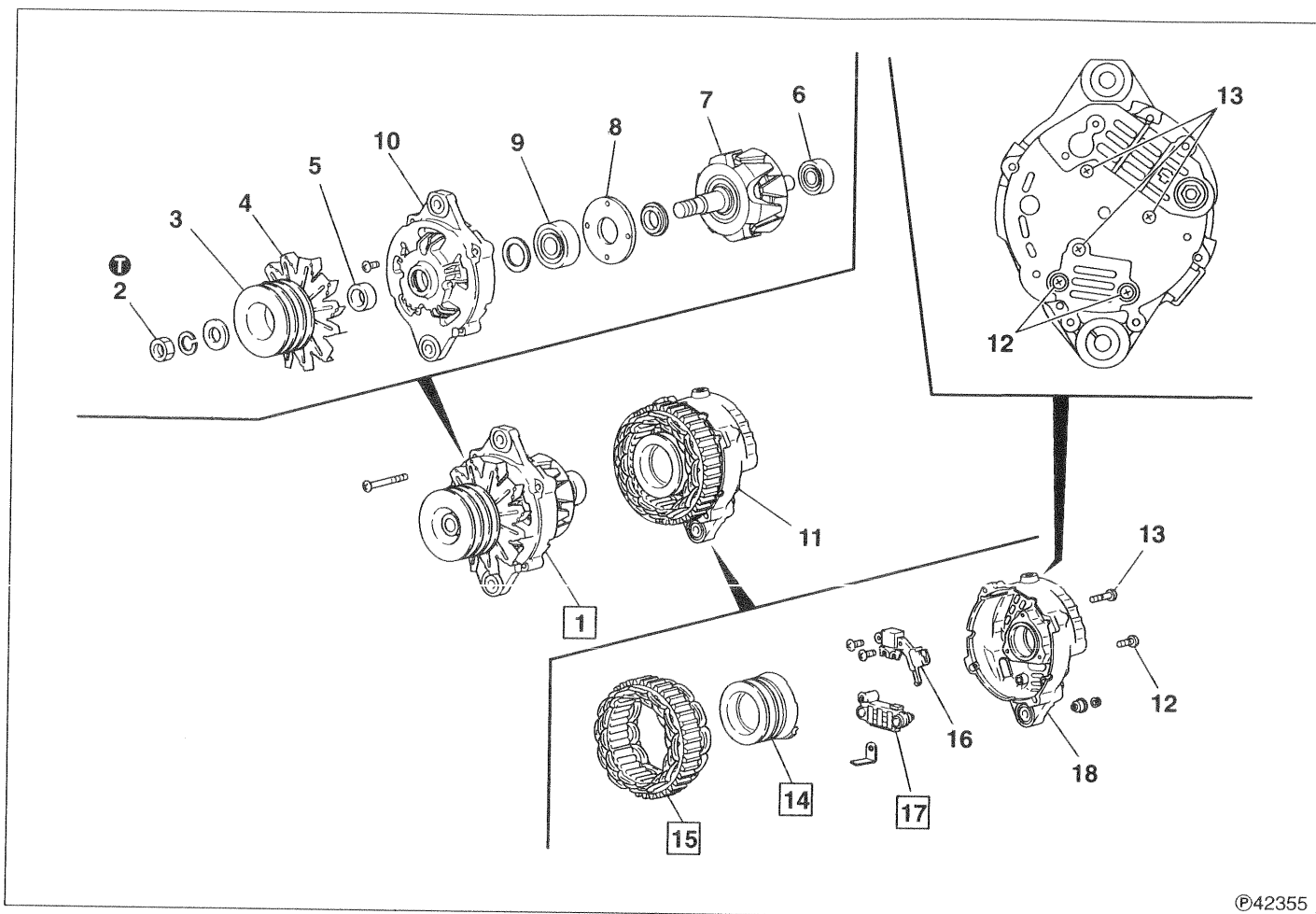

©42355

### ● Disassembly sequence

- |                                  |                                   |  |
|----------------------------------|-----------------------------------|--|
| 1 Rotor & front bracket assembly | 7 Rotor assembly                  | 13 Screw   |
| 2 Nut                            | 8 Cover                           | 14 Field coil  |
| 3 Pulley                         | 9 Front bearing                   | 15 Stator assembly   |
| 4 Fan                            | 10 Front bracket                  | 16 Regulator  P.54-85 |
| 5 Spacer                         | 11 Stator & rear bracket assembly | 17 Rectifier   |
| 6 Rear bearing                   | 12 Screw                          | 18 Rear bracket  |

### NOTE

Do not remove parts 6, 9 and 15 unless they are found to be defective.

### ● Reassembly sequence

11 → 1

11:

18 → 17 }  
16 } → 15 → 14 → 13 → 12

1:

10 → 9 → 8 }  
7 → 6 } → 5 → 4 → 3 → 2

## Service standards

Location	Maintenance item	Standard value	Limit	Remedy
14	Field coil resistance (at 20°C)	5.1 to 6.0 Ω	—	Replace

## Tightening torques

Unit: N · m {kgf · m}

Location	Parts to be tightened	Tightening torque	Remarks
2	Nut (to mount pulley)	132 to 162 {13.5 to 16.5}	—

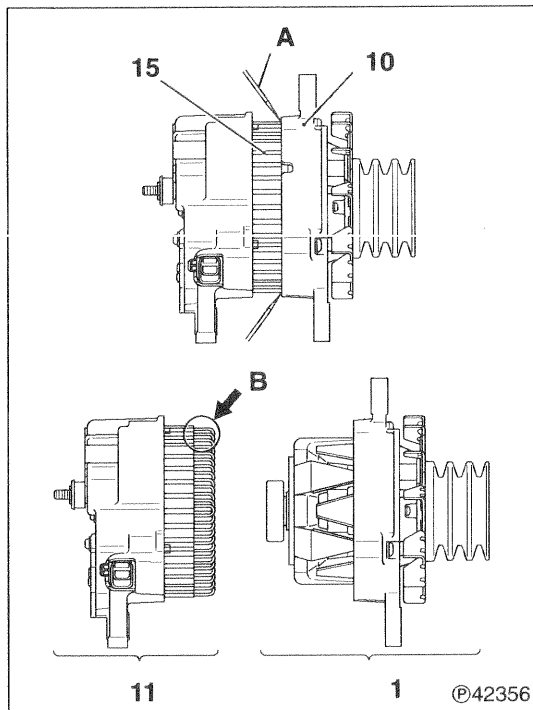

## Service procedure

### 1 Rotor & front bracket assembly

[Removal]

- Insert a plain screwdriver **A** between the front bracket **10** and stator assembly **15**.
- While wrenching the plain screwdriver **A**, remove the rotor & front bracket assembly **1** from the stator & rear bracket assembly **11**.

### CAUTION ⚠

If the plain screwdriver **A** is inserted too far, the coil **B** of the stator assembly **15** might be damaged and short-circuited.

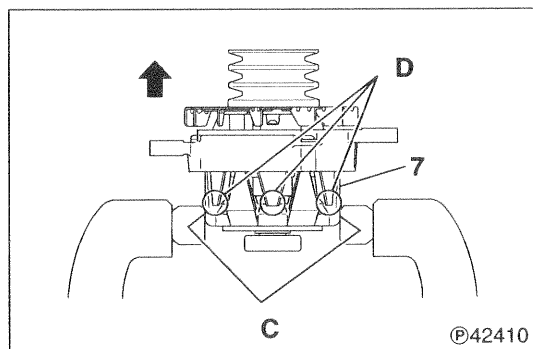

[Disassembly]

### CAUTION ⚠

When the rotor assembly **7** is held in a vice, make sure that the base **C** of the lugs of the core is held.

If the lugs **D** of the core are held, they will be broken or damaged.

# ALTERNATOR <24V-50A>

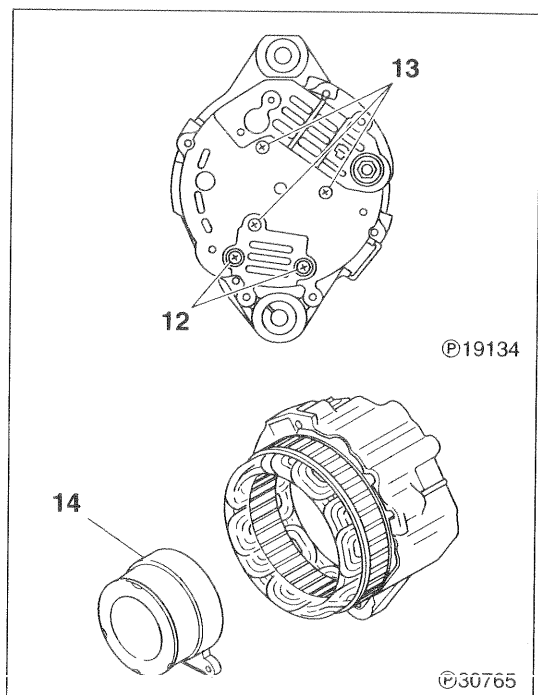

## 14 Field coil

[Removal]

- Remove the two screws 12.

### CAUTION ⚠

If the screws 13 are removed first, the weight of the field coil 14 will act on the portion connected to the regulator 16 and secured by the screws 12, and damage to the connected portion may result. Therefore, make sure that the screws 13 are removed first.

- Remove the three screws 13.

### CAUTION ⚠

When the screws 13 are removed, the field coil 14 will fall under its own weight. Therefore, hold the field coil by hand beforehand.

- Remove the field coil 14.

### CAUTION ⚠

When the field coil 14 is taken out, the portion connected to the regulator 16 may be caught by the stator coil. Don't pull it out with undue force.

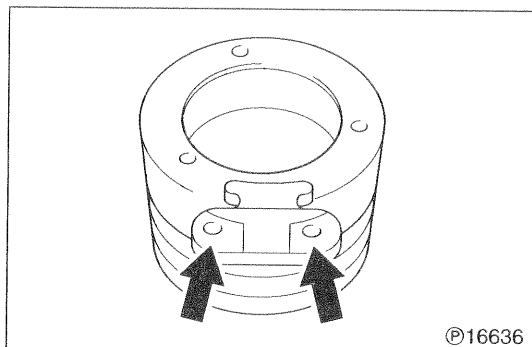

[Inspection]

- Measure the resistance between terminals of the field coil 14.
- If the reading is out of the standard value, replace the field coil 14.

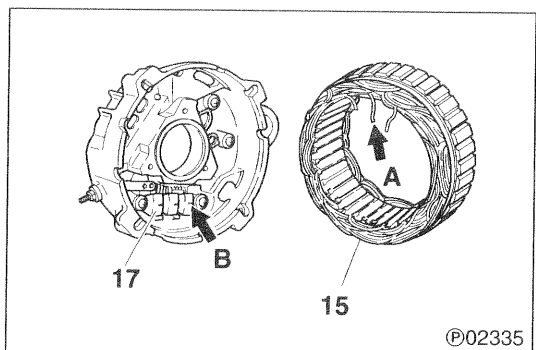

## 15 Stator assembly

[Removal]

- Disconnect the leads A and remove the stator assembly 15 from the rectifier 17.

The leads are soldered to the diode B of the rectifier. (four places)

### CAUTION ⚠

De-soldering should be done quickly (in about 5 seconds or less). The diodes will be damaged if heated for a longer time.

- For installation, reverse the order of removal.

[Inspection]

**(1) Continuity between leads**

- Check to ensure that there is continuity between each lead.
- If there is no continuity, the leads are open-circuited. Replace the stator assembly 15.

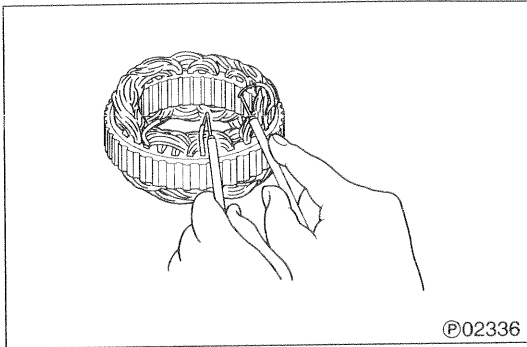

**(2) Continuity between each lead and core**

- Check to ensure that there is no continuity between each lead and the core.
- If there is continuity, it means a short circuit. Replace the stator assembly 15.

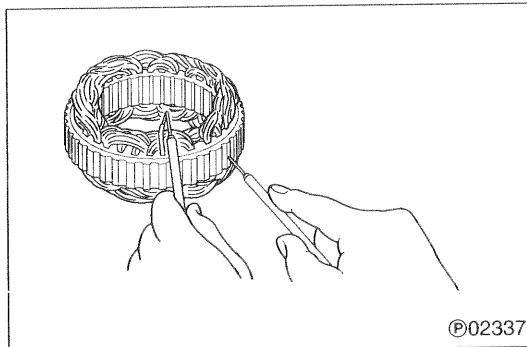

**17 Inspection of rectifier**

- Check the rectifier 17 to see if the internal diodes function properly, and replace if defective.

Resistance infinite in both cases....Open  
Resistance close to  $\Omega$  in both cases...Short

A, B, C, D: Leads of stator coil connected  
E, G: Heat sink portion  
F: Regulator connected

- Exchange the  $\oplus$  and  $\ominus$  sides of the tester and perform checks in both cases.

**CAUTION**

When a tester is used for the checks, the current that flows out from the tester is feebler than the current that normally flows through the rectifier 17, so the tester may indicate a questionable resistance value. In a low range, this tendency will be stronger. Therefore, it is advisable to use the highest possible range.

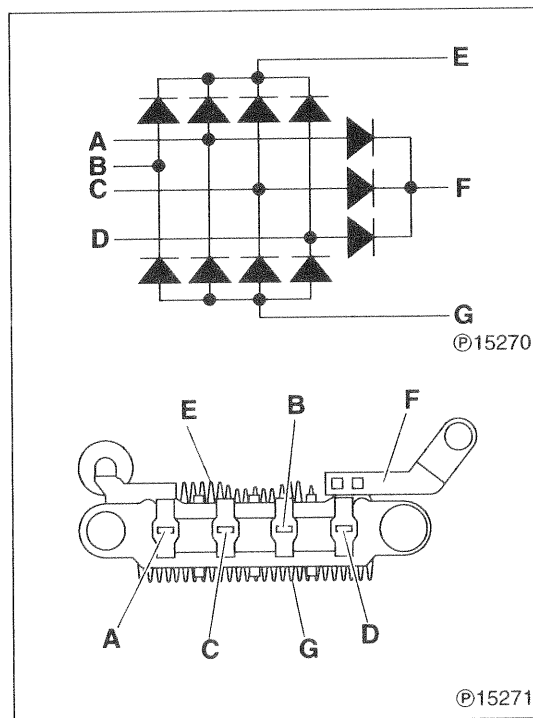

# ALTERNATOR <24V-80A (brushless)>

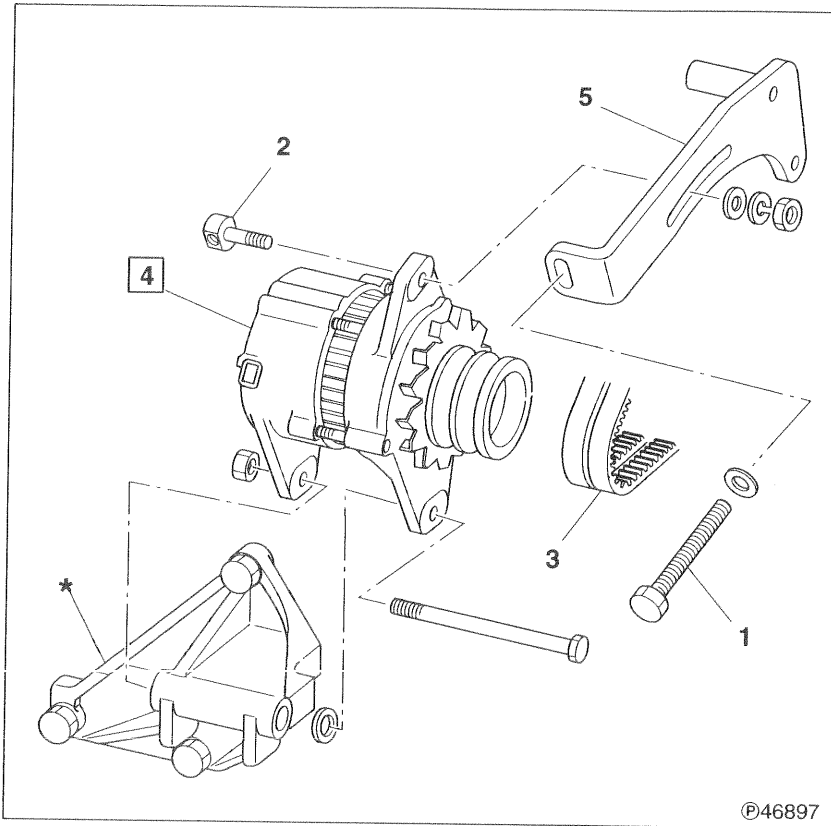

## ● Removal sequence

- 1 Adjust bolt
- 2 Adjust shaft
- 3 V-belt
- 4 Alternator assembly P.54-92
- 5 Adjust plate

\*: Alternator bracket

## WARNING

Before removing the alternator 4, be sure to disconnect the negative  $\ominus$  terminal of the battery and insulate it with a tape or something else. If the negative  $\ominus$  terminal is not disconnected, the battery voltage is always available at terminal B and is dangerous.

## ● Installation sequence

Reverse the order of removal.

## ● Adjustment after installation

Adjust the tension of the V-belt 3. Gr 14

## Service standards

Location	Maintenance item			Standard value	Limit	Remedy	
4	Alternator output current (When 27V is generated)	Alternator speed	When cold	1500 rpm	56A or more	—	Check
				2500 rpm	86A or more	—	
		* When hot	5000 rpm	77A or more	—		
	Regulator regulated voltage (5000 rpm, loads 5A or less)			28.5 ± 0.5V	—	Replace	

\*: "When hot" refers to the state of the engine after 30 minutes of maximum output operation at 5000 rpm at a normal ambient temperature.

## ◆ Service procedure

### 4 Inspection of alternator

#### (1) Inspection of performance of alternator (Inspection by test bench)

- Wire the alternator 4 as shown.

#### NOTE

Each wire must be adequately thick and each connection must be properly secured.

- A: Ammeter
- B: Alternator terminal B
- C: Switch
- D: Switch
- E: Alternator terminal E
- F: Load resistance (variable resistance)
- G: Alternator drive motor
- L: Alternator terminal L
- R: Alternator terminal R
- V: Voltmeter

- Increase the load resistance **F** to a maximum (where practically no load current flows).
- Set the switch **C** and switch **D** to ON.
- Operate the alternator **4** at 5000 rpm for 30 minutes with the load resistance **F** adjusted such that the output current is as specified in "Service standard".

Nominal value of alternator current

24V-80A

- Measure the current with the alternator **4** at each of the specified speeds.
- If the reading is out of the standard value, disassemble and check the alternator **4**. P.54-92

#### (2) Inspection of performance of regulator (Inspection by test bench)

- Wire the alternator **4** as shown.

- A: Ammeter
- B: Alternator terminal B
- C: Switch
- E: Alternator terminal E
- G: Alternator drive motor
- L: Alternator terminal L
- R: Alternator terminal R
- V: Voltmeter

- Set the switch **C** to ON.
- Let the alternator **4** rotate at a low speed.
- Increase the rotating speed of the alternator **4** to 5000 rpm and measure the voltage (regulated voltage). At the same time, check to ensure that the current value is 5A or less.
- If the readings are out of the standard values, proceed as described below.
  - If the readings exceed the standard values, replace the regulator.
  - If the readings are below the standard values, check all the parts of the alternator before replacing the regulator.

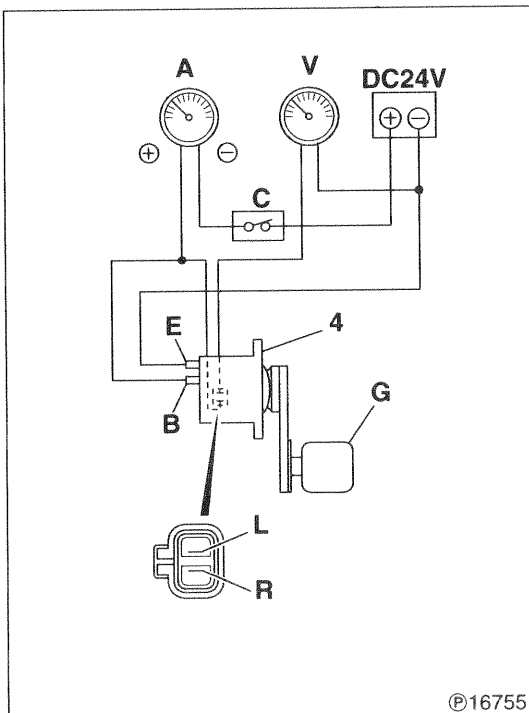
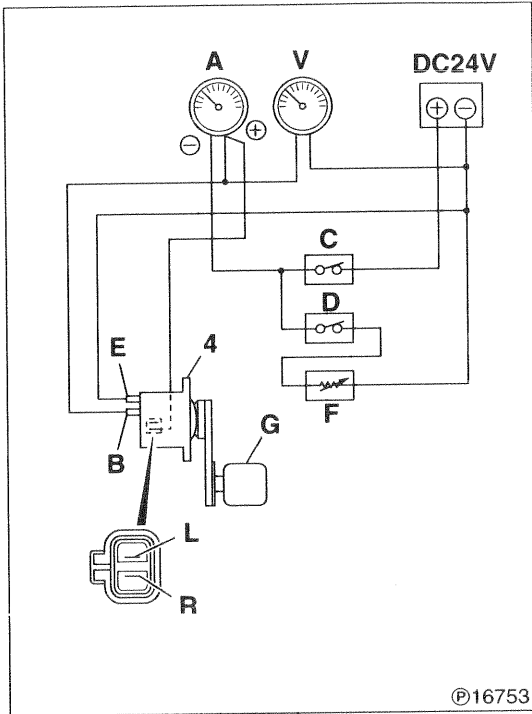

# ALTERNATOR <24V-80A (brushless)>

## Alternator Assembly

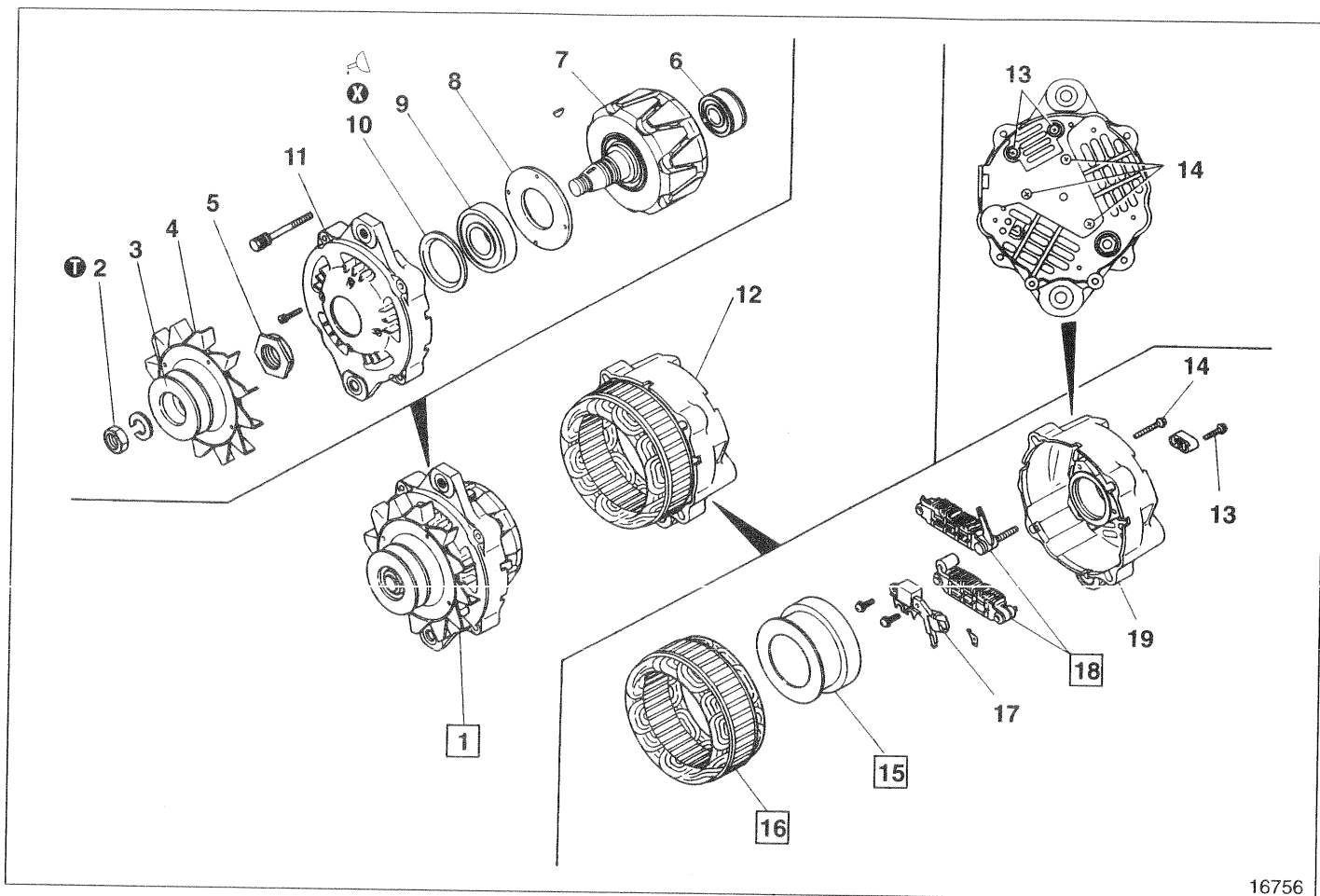

16756

### Disassembly sequence

- |                                  |                                   |                       |
|----------------------------------|-----------------------------------|-----------------------|
| 1 Rotor & front bracket assembly | 8 Cover                           | 15 Field coil         |
| 2 Nut                            | 9 Front bearing                   | 16 Stator assembly    |
| 3 Pulley                         | 10 Oil seal                       | 17 Regulator  P.54-91 |
| 4 Fan                            | 11 Front bracket                  | 18 Rectifier          |
| 5 Nut                            | 12 Stator & rear bracket assembly | 19 Rear bracket       |
| 6 Rear bearing                   | 13 Screw                          |                       |
| 7 Rotor assembly                 | 14 Screw                          |                       |

: Non-reusable part

### NOTE

Do not remove parts 6, 9 and 16 unless they are found to be defective.

### Reassembly sequence

12 → 1

12: 

19 → 18	}	→ 16 → 15 → 14 → 13
17		

1: 

11 → 10 → 9 → 8	}	→ 5 → 4 → 3 → 2
7 → 6		

## Service standards

Location	Maintenance item	Standard value	Limit	Remedy
15	Field coil resistance (at 20°C)	2.6 to 3.4 Ω	—	Replace

## ⓘ Tightening torques

Unit: N·m {kgf·m}

Location	Parts to be tightened	Tightening torque	Remarks
2	Nut (to mount pulley)	132 to 162 {13.5 to 16.5}	—

## 🔊 Lubricants

Location	Points of application	Kinds	Quantity
10	Apply to the oil seal lip	Supplied with the service part oil seal	As required

## ◆ Service procedure

### 1 Rotor & front bracket assembly

[Removal]

- Insert a plain screwdriver **A** between the front bracket **11** and stator assembly **16**.
- While wrenching the plain screwdriver **A**, remove the rotor & front bracket assembly **1** from the stator & rear bracket assembly **12**.

### CAUTION ⚠

If the plain screwdriver **A** is inserted too far, the coil **B** of the stator assembly **16** might be damaged and short-circuited.

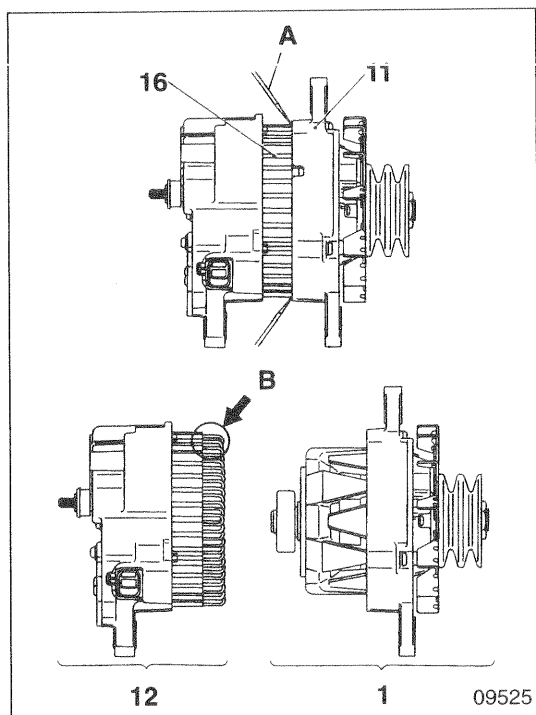

[Disassembly]

### CAUTION ⚠

When the rotor assembly **7** is held in a vice, make sure that the base **C** of the lugs of the core is held. If the lugs **D** of the core are held, they will be broken or damaged.

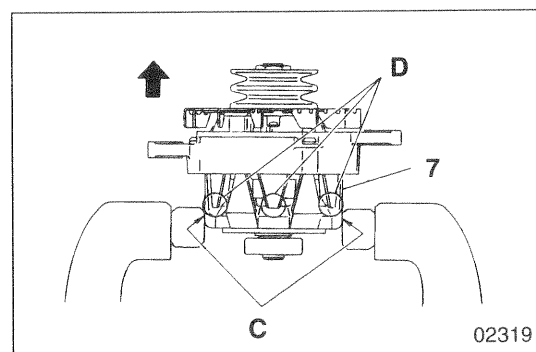

# ALTERNATOR <24V-80A (brushless)>

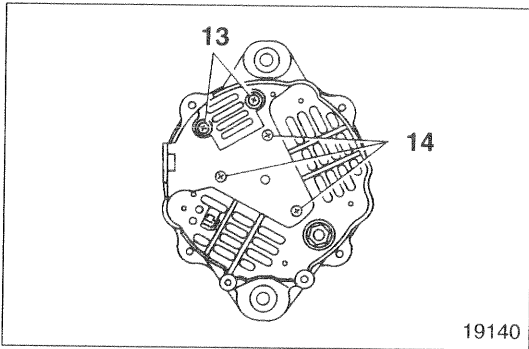

## 15 Field coil

[Removal]

- Remove the two screws 13.

### CAUTION ⚠

If the screws 14 are removed first, the weight of the field coil 15 will act on the lead portion secured by the screws 13, and damage to the lead portion may result. Therefore, make sure that the screws 13 are removed first.

- Remove the three screws 14.

### CAUTION ⚠

When the screws 14 are removed, the field coil 15 will fall under its own weight. Therefore, hold the field coil by hand beforehand.

- Remove the field coil 15.

### CAUTION ⚠

When the field coil 15 is taken out, the coil lead portion may be caught by the stator coil. Don't pull it out with undue force.

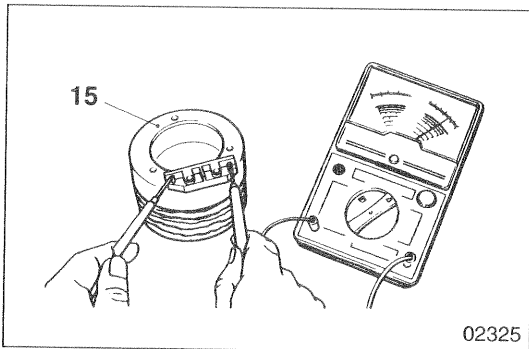

[Inspection]

- Measure the resistance between terminals of the field coil 15.
- If the reading is out of the standard value, replace the field coil 15.

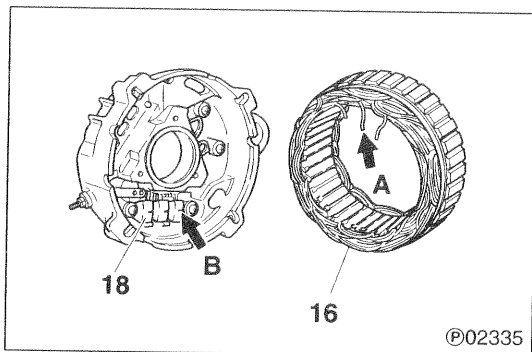

## 16 Stator assembly

[Removal]

- Disconnect the leads A and remove the stator assembly 16 from the rectifier 18.

The leads are soldered to the diode leads B of the rectifier. (Three places)

### CAUTION ⚠

De-soldering should be done quickly (in about 5 seconds or less). The diodes will be damaged if heated for a longer time.

- For installation, reverse the order of removal.

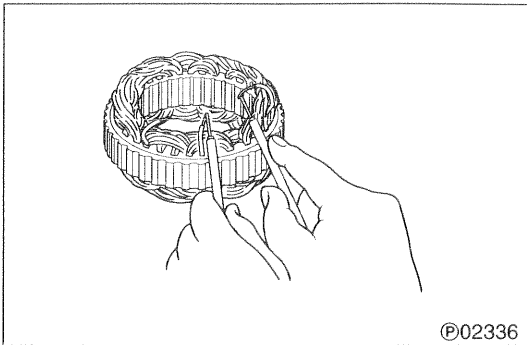

[Inspection]

**(1) Continuity between leads**

- Check to ensure that there is continuity between each lead.
- If there is no continuity, the leads are open-circuited. Replace the stator assembly 16.

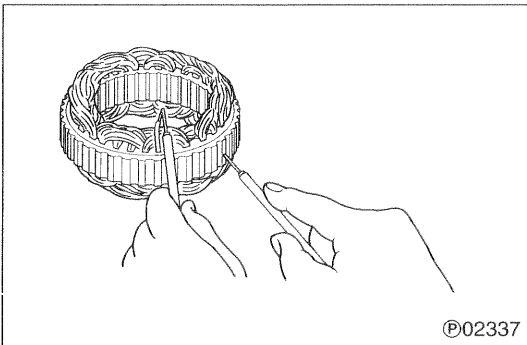

**(2) Continuity between each lead and core**

- Check to ensure that there is no continuity between each lead and the core.
- If there is continuity, it means a short circuit. Replace the stator assembly 16.

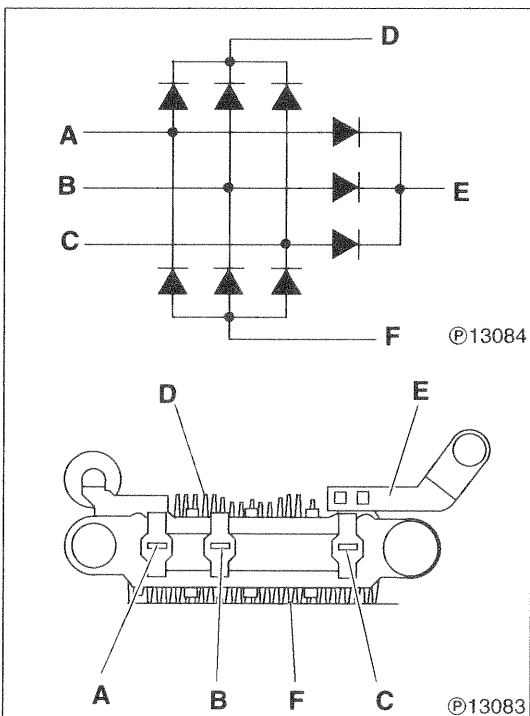

**18 Inspection of rectifier**

- Check the rectifier 18 to see if the internal diodes function properly, and replace if defective.

Resistance infinite in both cases...Open

Resistance close to  $\Omega$  in both cases...Short

A, B, C: Leads of stator coil connected

D, F: Heat sink portion

E: Regulator connected

- Exchange the  $\oplus$  and  $\ominus$  sides of the tester and perform checks in both cases.

**CAUTION**

When a tester is used for the checks, the current that flows out from the tester is feebler than the current that normally flows through the rectifier 18, so the tester may indicate a questionable resistance value. In a low range, this tendency will be stronger. Therefore, it is advisable to use the highest possible range.

# ALTERNATOR <24V-90A>

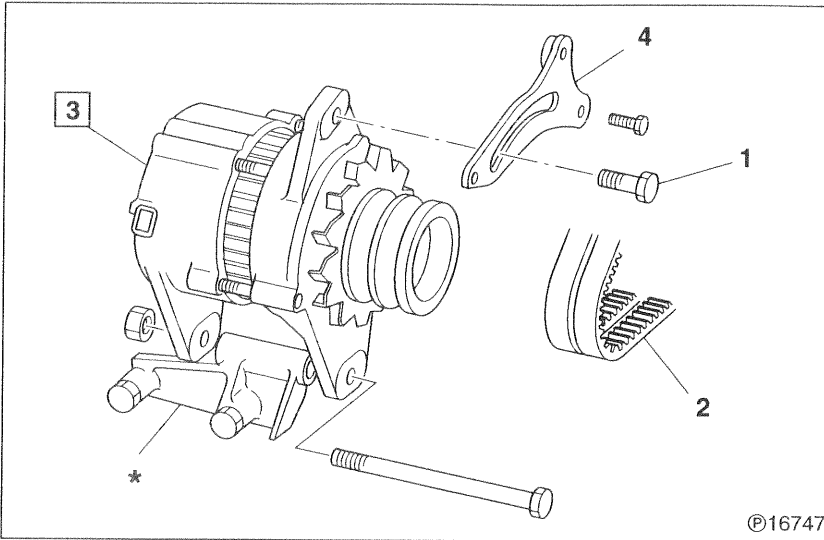

## ● Removal sequence

- 1 Adjust bolt
- 2 V-belt
- 3 Alternator assembly P.54-98
- 4 Adjust plate

\*: Alternator bracket

- A: Connect to terminals L and R.  
 B: Connect to terminal B.  
 C: Connect to terminal C.  
 E: Connect to terminal E.

## WARNING

Before removing the alternator 3, be sure to disconnect the negative  $\ominus$  terminal of the battery and insulate it with a tape or something else. If the negative  $\ominus$  terminal is not disconnected, the battery voltage is always available at terminal B and is dangerous.

## ● Installation sequence

Reverse the order of removal.

## ● Adjustment after installation

Adjust the tension of the V-belt 2. Gr 14

## Service standards

Location	Maintenance item			Standard value	Limit	Remedy	
3	Alternator output current (When 27V is generated)	Alternator speed	When cold	1500 rpm	53A or more	—	Check
				2500 rpm	82A or more	—	
		*When hot	5000 rpm	86A or more	—		
	Regulator regulated voltage (5000 rpm, loads 5A or less)				28.5 ± 0.5V	—	Replace

\*: "When hot" refers to the state of the engine after 30 minutes of maximum output operation at 5000 rpm at a normal ambient temperature.

## ◆ Service procedure

### 3 Inspection of alternator

#### (1) Inspection of performance of alternator

(Inspection by test bench)

- Wire the alternator 3 as shown.

#### NOTE

Each wire must be adequately thick and each connection must be properly secured.

A: Ammeter

B: Alternator terminal B

C: Switch

D: Switch

E: Alternator terminal E

F: Load resistance (variable resistance)

G: Alternator drive motor

L: Alternator terminal L

R: Alternator terminal R

V: Voltmeter

- Increase the load resistance F to a maximum (where practically no load current flows).
- Set the switch C and switch D to ON.
- Operate the alternator 3 at 5000 rpm for 30 minutes with the load resistance F adjusted such that the output current is as specified in "Service standard".

Nominal value of alternator current

24V-90A

- Measure the current with the alternator 3 at each of the specified speeds.
- If the reading is out of the standard value, disassemble and check the alternator 3. P.54-98

#### (2) Inspection of performance of regulator

(Inspection by test bench)

- Wire the alternator 3 as shown.

A: Ammeter

B: Alternator terminal B

C: Switch

E: Alternator terminal E

G: Alternator drive motor

L: Alternator terminal L

R: Alternator terminal R

V: Voltmeter

- Set the switch C to ON.
- Let the alternator 3 rotate at a low speed.
- Increase the rotating speed of the alternator 3 to 5000 rpm and measure the voltage (regulated voltage). At the same time, check to ensure that the current value is 5A or less.
- If the readings are out of the standard values, proceed as described below.
  - If the readings exceed the standard values, replace the regulator.
  - If the readings are below the standard values, check all the parts of the alternator before replacing the regulator.

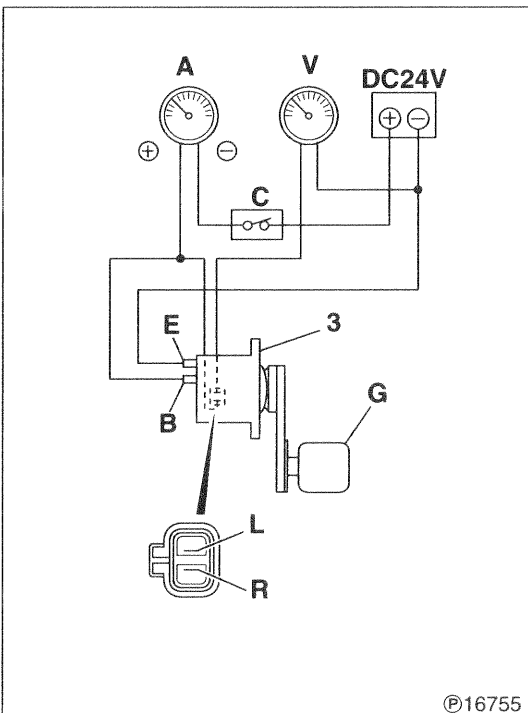
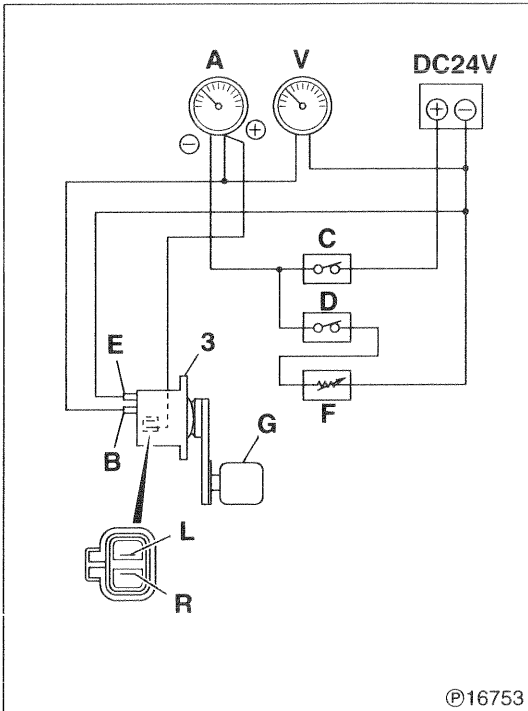

# ALTERNATOR <24V-90A>

## Alternator Assembly

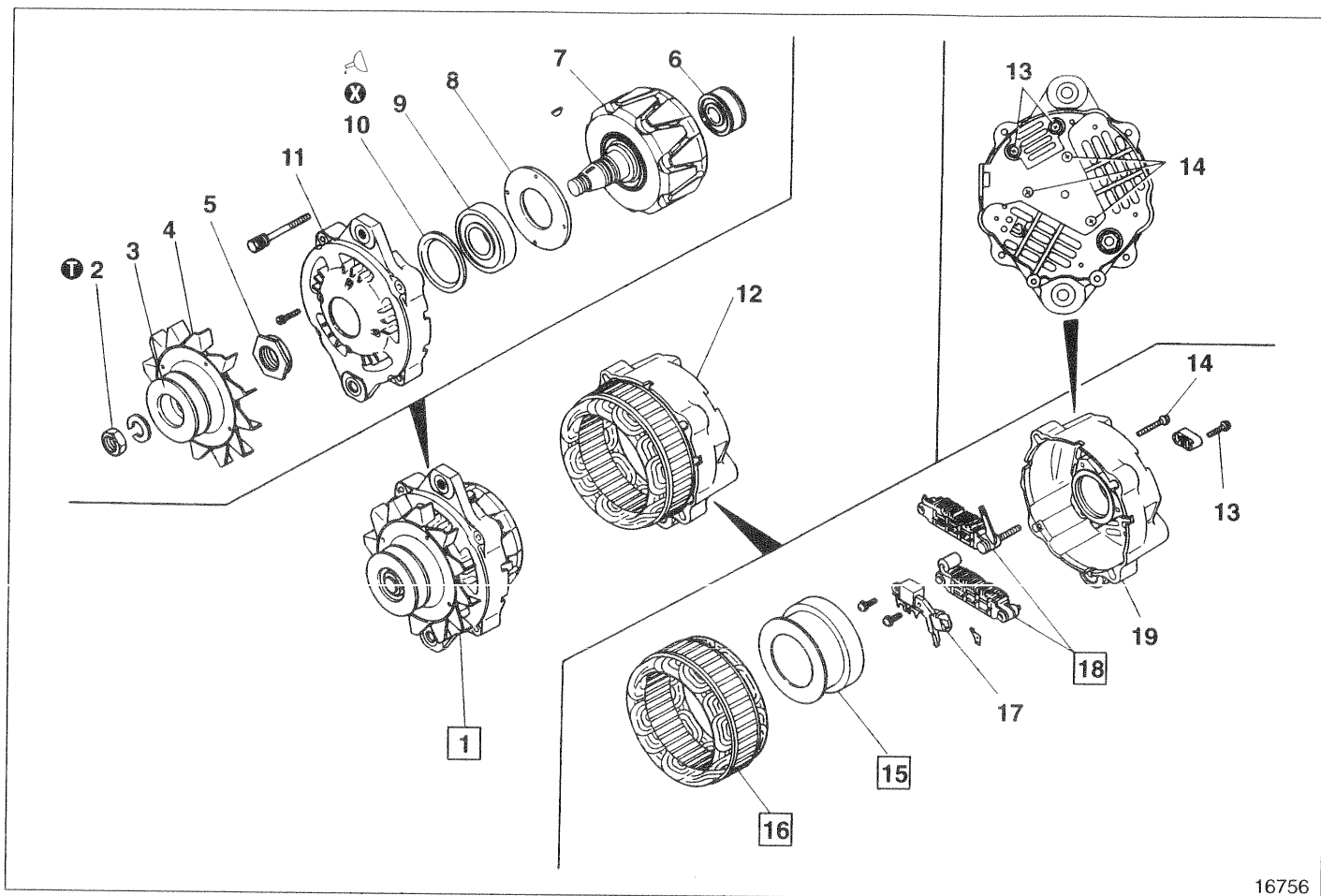

16756

### Disassembly sequence

- |                                  |                                   |                       |
|----------------------------------|-----------------------------------|-----------------------|
| 1 Rotor & front bracket assembly | 8 Cover                           | 15 Field coil         |
| 2 Nut                            | 9 Front bearing                   | 16 Stator assembly    |
| 3 Pulley                         | 10 Oil seal                       | 17 Regulator  P.54-97 |
| 4 Fan                            | 11 Front bracket                  | 18 Rectifier          |
| 5 Nut                            | 12 Stator & rear bracket assembly | 19 Rear bracket       |
| 6 Rear bearing                   | 13 Screw                          |                       |
| 7 Rotor assembly                 | 14 Screw                          |                       |

⊗ : Non-reusable part

### NOTE

Do not remove parts 6, 9 and 16 unless they are found to be defective.

### Reassembly sequence

12 → 1

12:

19 → 18  
17 } → 16 → 15 → 14 → 13

1:

11 → 10 → 9 → 8  
7 → 6 } → 5 → 4 → 3 → 2

## Service standards

Location	Maintenance item	Standard value	Limit	Remedy
15	Field coil resistance (at 20°C)	2.6 to 3.4 Ω	—	Replace

## ⓘ Tightening torques

Unit: N·m {kgf·m}

Location	Parts to be tightened	Tightening torque	Remarks
2	Nut (to mount pulley)	132 to 162 {13.5 to 16.5}	—

## 🔊 Lubricants

Location	Points of application	Kinds	Quantity
10	Apply to the oil seal lip	Supplied with the service part oil seal	As required

## ◆ Service procedure

### 1 Rotor & front bracket assembly

[Removal]

- Insert a plain screwdriver **A** between the front bracket **11** and stator assembly **16**.
- While wrenching the plain screwdriver **A**, remove the rotor & front bracket assembly **1** from the stator & rear bracket assembly **12**.

### CAUTION ⚠

If the plain screwdriver **A** is inserted too far, the coil **B** of the stator assembly **16** might be damaged and short-circuited.

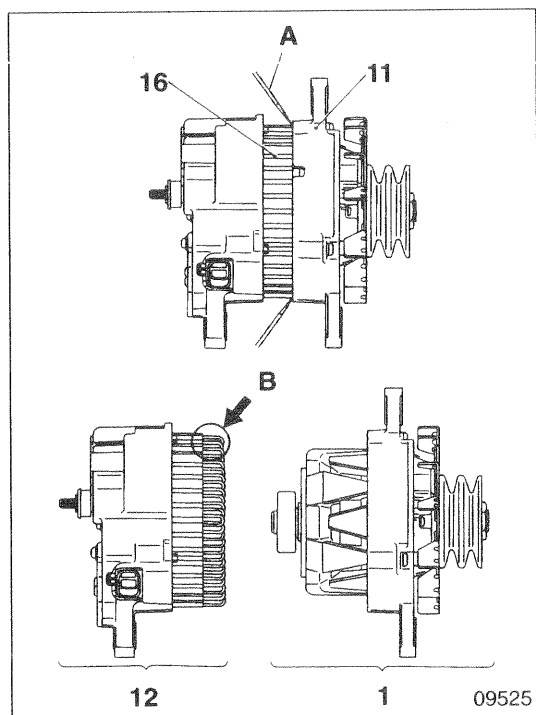

[Disassembly]

### CAUTION ⚠

When the rotor assembly **7** is held in a vice, make sure that the base **C** of the lugs of the core is held.  
If the lugs **D** of the core are held, they will be broken or damaged.

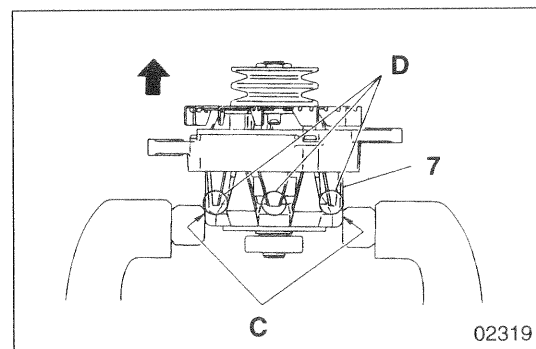

# ALTERNATOR <24V-90A>

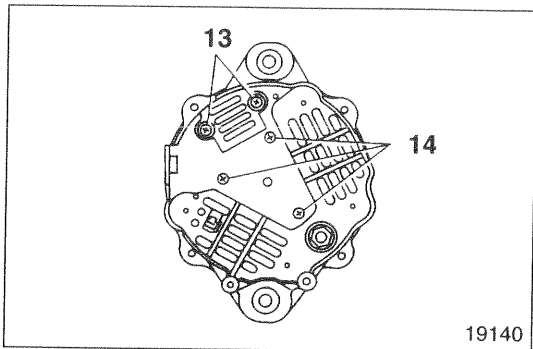

## 15 Field coil

[Removal]

- Remove the two screws 13.

### CAUTION

If the screws 14 are removed first, the weight of the field coil 15 will act on the lead portion secured by the screws 13, and damage to the lead portion may result. Therefore, make sure that the screws 13 are removed first.

- Remove the three screws 14.

### CAUTION

When the screws 14 are removed, the field coil 15 will fall under its own weight. Therefore, hold the field coil by hand beforehand.

- Remove the field coil 15.

### CAUTION

When the field coil 15 is taken out, the coil lead portion may be caught by the stator coil. Don't pull it out with undue force.

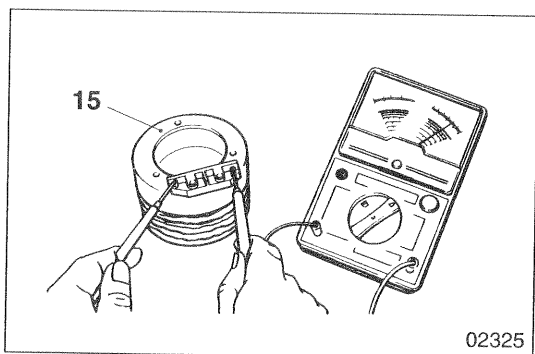

[Inspection]

- Measure the resistance between terminals of the field coil 15.
- If the reading is out of the standard value, replace the field coil 15.

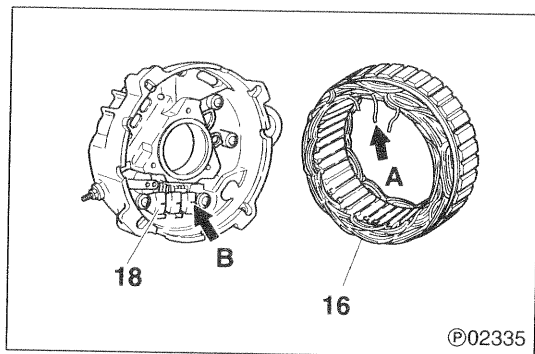

## 16 Stator assembly

[Removal]

- Disconnect the leads A and remove the stator assembly 16 from the rectifier 18.

The leads are soldered to the diode leads B of the rectifier. (Three places)

### CAUTION

De-soldering should be done quickly (in about 5 seconds or less). The diodes will be damaged if heated for a longer time.

- For installation, reverse the order of removal.

[Inspection]

**(1) Continuity between leads**

- Check to ensure that there is continuity between each lead.
- If there is no continuity, the leads are open-circuited. Replace the stator assembly 16.

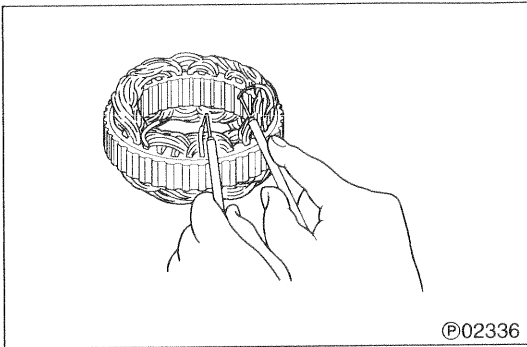

**(2) Continuity between each lead and core**

- Check to ensure that there is no continuity between each lead and the core.
- If there is continuity, it means a short circuit. Replace the stator assembly 16.

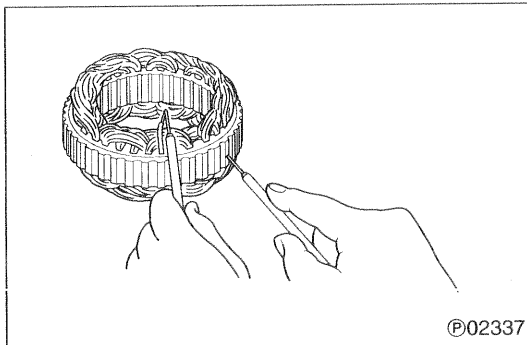

**18 Inspection of rectifier**

- Check the rectifier 18 to see if the internal diodes function properly, and replace if defective.

Resistance infinite in both cases...Open  
Resistance close to  $\Omega$  in both cases...Short

A, B, C, D: Leads of stator coil connected

E, G: Heat sink portion

F: Regulator connected

- Exchange the  $\oplus$  and  $\ominus$  sides of the tester and perform checks in both cases.

**CAUTION**

When a tester is used for the checks, the current that flows out from the tester is feeble than the current that normally flows through the rectifier 18, so the tester may indicate a questionable resistance value. In a low range, this tendency will be stronger. Therefore, it is advisable to use the highest possible range.

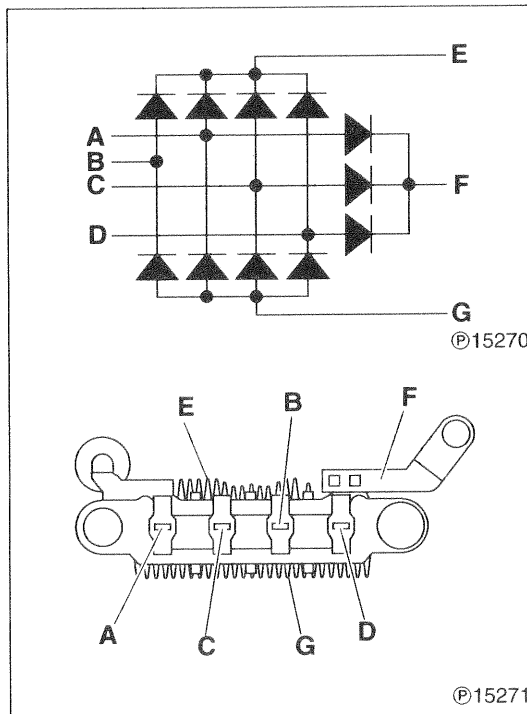

# ALTERNATOR <12V-80A>

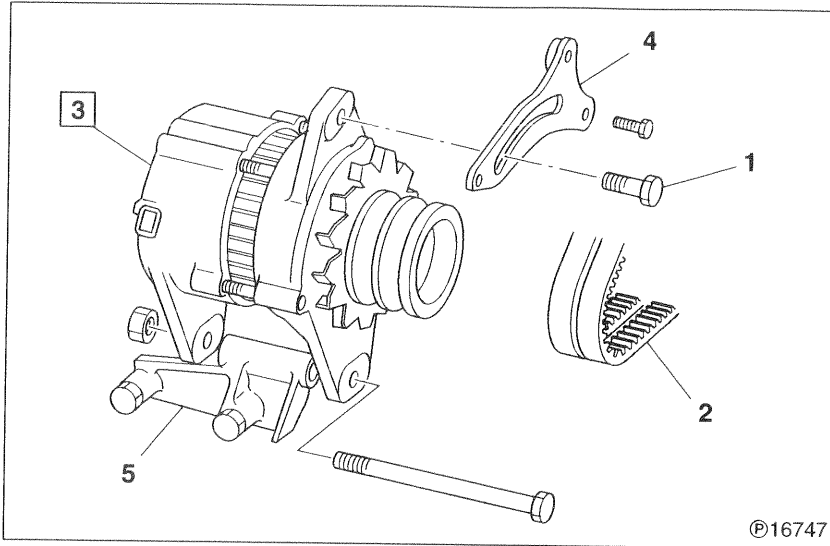

## ● Removal sequence

- 1 Adjust bolt
- 2 V-belt
- 3 Alternator assembly P.54-104
- 4 Adjust plate
- 5 Alternator bracket

©16747

## WARNING

Before removing the alternator 3, be sure to disconnect the negative  $\ominus$  terminal of the battery and insulate it with a tape or something else. If the negative  $\ominus$  terminal is not disconnected, the battery voltage is always available at terminal B and is dangerous.

## ● Installation sequence

Reverse the order of removal.

## ● Adjustment after installation

Adjust the tension of the V-belt 2. Gr 14

## Service standards

Location	Maintenance item		Standard value	Limit	Remedy
3	Alternator output current (* When hot, when 13.5V is generated)	Alternator speed	1500 rpm	38A or more	Check
			2500 rpm	65A or more	
			5000 rpm	76A or more	
	Regulator regulated voltage (5000 rpm, loads 5A or less)		14.7 ± 0.3V	—	Replace

\*: "When hot" refers to the state of the engine after 30 minutes of maximum output operation at 5000 rpm at a normal ambient temperature.

## ◆ Service procedure

### 3 Inspection of alternator

#### (1) Inspection of performance of alternator (Inspection by test bench)

- Wire the alternator 3 as shown.

#### NOTE

Each wire must be adequately thick and each connection must be properly secured.

- A: Ammeter  
 B: Alternator terminal B  
 C: Switch  
 D: Switch  
 E: Alternator terminal E  
 F: Load resistance (variable resistance)  
 G: Alternator drive motor  
 L: Alternator terminal L  
 R: Alternator terminal R  
 V: Voltmeter

- Increase the load resistance F to a maximum (where practically no load current flows).
- Set the switch C and switch D to ON.
- Operate the alternator 3 at 5000 rpm for 30 minutes with the load resistance F adjusted such that the output current is as specified in "Service standard".

Nominal value of alternator current

12V-80A

- Measure the current with the alternator 3 at each of the specified speeds.
- If the reading is out of the standard value, disassemble and check the alternator 3. P.54-104

#### (2) Inspection of performance of regulator

(Inspection by test bench)

- Wire the alternator 3 as shown.

- A: Ammeter  
 B: Alternator terminal B  
 C: Switch  
 E: Alternator terminal E  
 G: Alternator drive motor  
 L: Alternator terminal L  
 R: Alternator terminal R  
 V: Voltmeter

- Set the switch C to ON.
- Let the alternator 3 rotate at a low speed.
- Increase the rotating speed of the alternator 3 to 5000 rpm and measure the voltage (regulated voltage). At the same time, check to ensure that the current value is 5A or less.
- If the readings are out of the standard values, proceed as described below.
  - If the readings exceed the standard values, replace the regulator.
  - If the readings are below the standard values, check all the parts of the alternator before replacing the regulator.

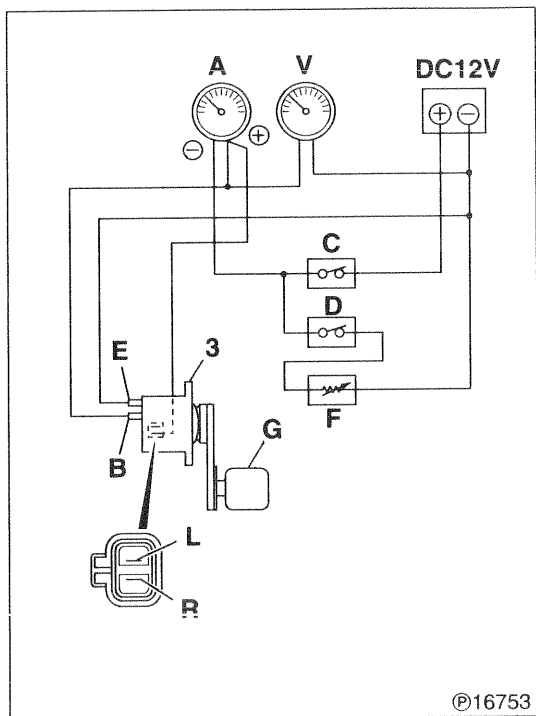

©16753

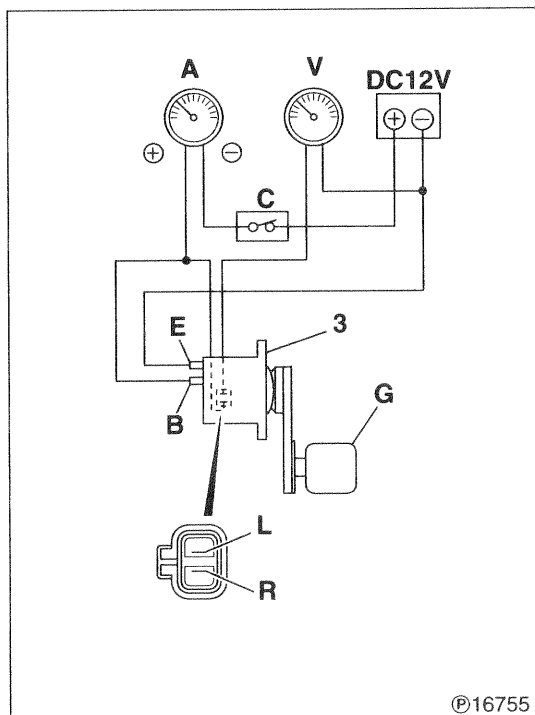

©16755

# ALTERNATOR <12V-80A>

## Alternator Assembly

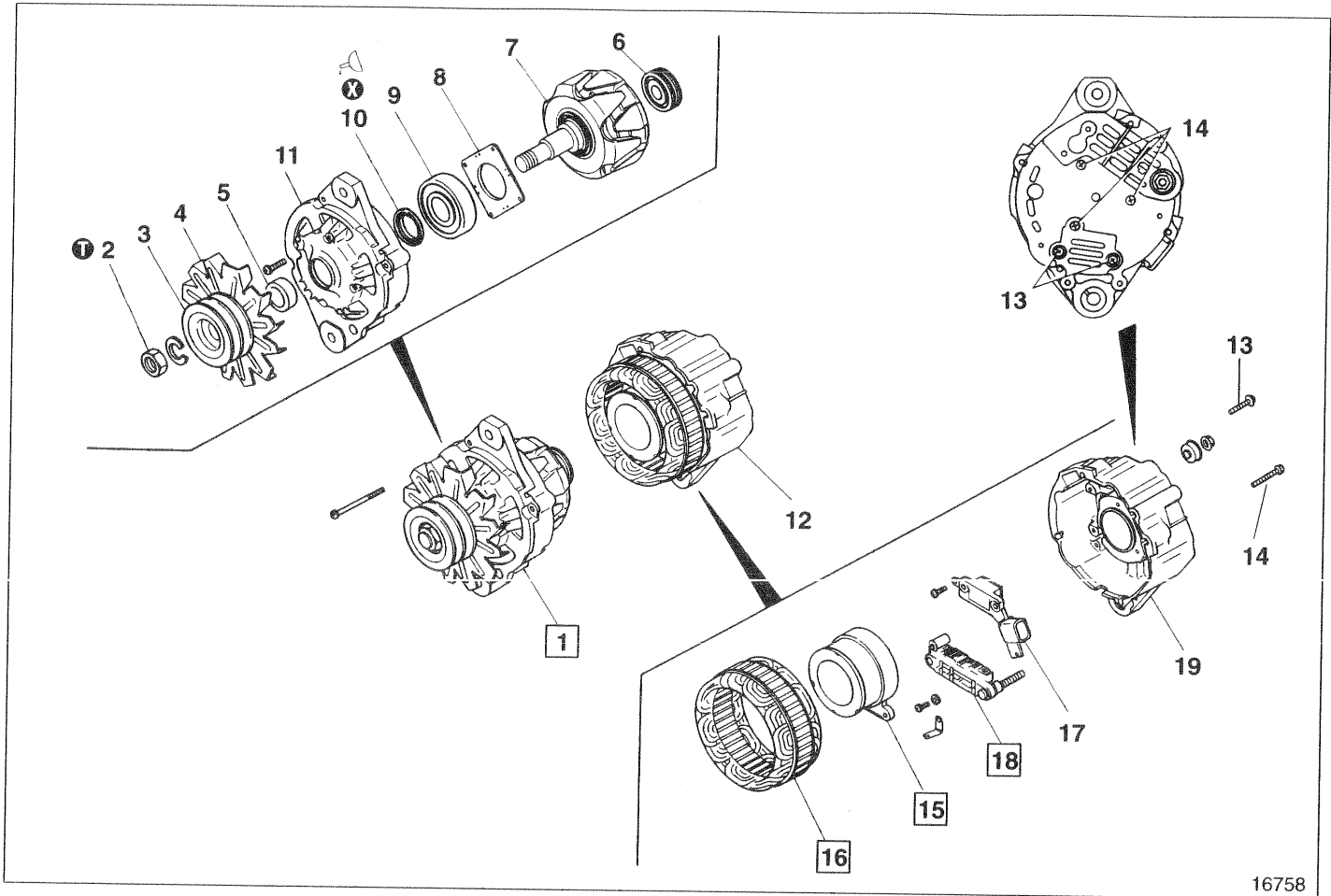

16758

### ● Disassembly sequence

- |                                  |                                   |                        |
|----------------------------------|-----------------------------------|------------------------|
| 1 Rotor & front bracket assembly | 8 Cover                           | 15 Field coil          |
| 2 Nut                            | 9 Front bearing                   | 16 Stator assembly     |
| 3 Pulley                         | 10 Oil seal                       | 17 Regulator  P.54-103 |
| 4 Fan                            | 11 Front bracket                  | 18 Rectifier           |
| 5 Spacer                         | 12 Stator & rear bracket assembly | 19 Rear bracket        |
| 6 Rear bearing                   | 13 Screw                          |                        |
| 7 Rotor assembly                 | 14 Screw                          |                        |

⊗ : Non-reusable part

### NOTE

Do not remove parts 6, 9 and 16 unless they are found to be defective.

### ● Reassembly sequence

12 → 1

12: 

19 → 18	}	16 → 15 → 14 → 13
17		

1: 

11 → 10 → 9 → 8	}	5 → 4 → 3 → 2
7 → 6		

## Service standards

Location	Maintenance item	Standard value	Limit	Remedy
15	Field coil resistance (at 20°C)	2.6 to 3.4 Ω	—	Replace

## ⓘ Tightening torques

Unit: N·m {kgf·m}

Location	Parts to be tightened	Tightening torque	Remarks
2	Nut (to mount pulley)	132 to 162 {13.5 to 16.5}	—

## 🔊 Lubricant

Location	Points of application	Specified lubricant	Quantity
10	Apply to the oil seal lip	Supplied with the service part oil seal	As required

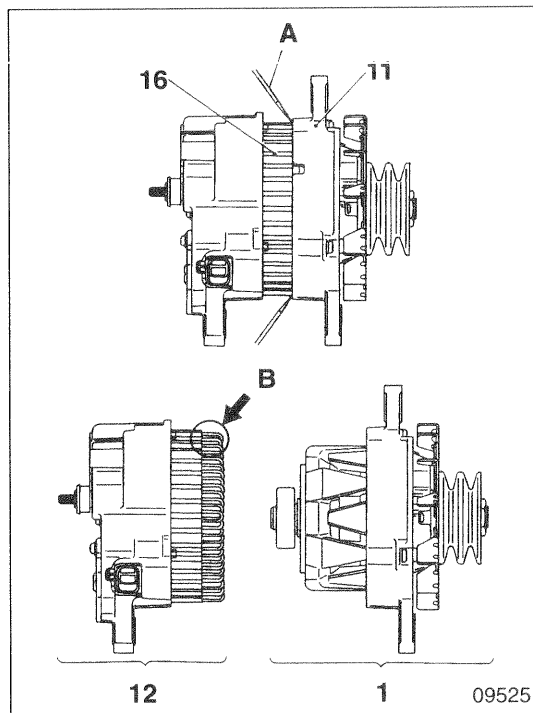

## ◆ Service procedure

### 1 Rotor & front bracket assembly

[Removal]

- Insert a plain screwdriver **A** between the front bracket **11** and stator assembly **16**.
- While wrenching the plain screwdriver **A**, remove the rotor & front bracket assembly **1** from the stator & rear bracket assembly **12**.

### CAUTION ⚠

If the plain screwdriver **A** is inserted too far, the coil **B** of the stator assembly **16** might be damaged and short-circuited.

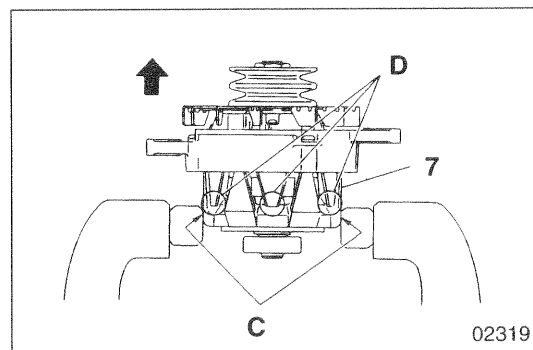

[Disassembly]

### CAUTION ⚠

When the rotor assembly **7** is held in a vice, make sure that the base **C** of the lugs of the core is held.  
If the lugs **D** of the core are held, they will be broken or damaged.

# ALTERNATOR <12V-80A>

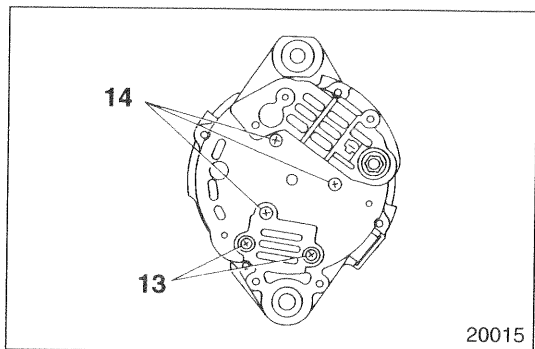

## 15 Field coil

[Removal]

- Remove the two screws 13.

### CAUTION ⚠

If the screws 14 are removed first, the weight of the field coil 15 will act on the lead portion secured by the screws 13, and damage to the lead portion may result. Therefore, make sure that the screws 13 are removed first.

- Remove the three screws 14.

### CAUTION ⚠

When the screws 14 are removed, the field coil 15 will fall under its own weight. Therefore, hold the field coil by hand beforehand.

- Remove the field coil 15.

### CAUTION ⚠

When the field coil 15 is taken out, the coil lead portion may be caught by the stator coil. Don't pull it out with undue force.

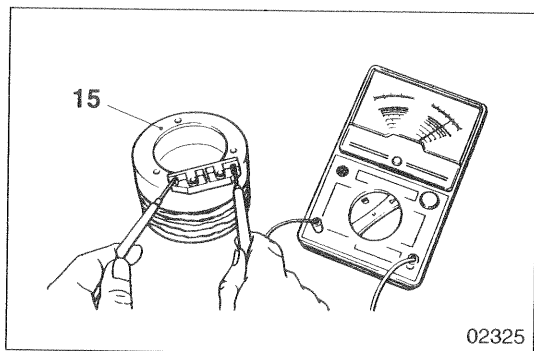

[Inspection]

- Measure the resistance between terminals of the field coil 15.
- If the reading is out of the standard value, replace the field coil 15.

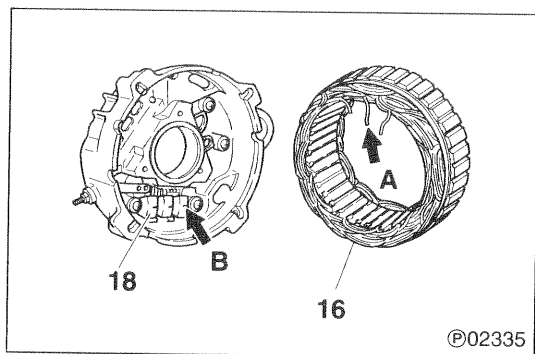

## 16 Stator assembly

[Removal]

- Disconnect the leads A and remove the stator assembly 16 from the rectifier 18.

The leads are soldered to the diode leads B of the rectifier. (Three places)

### CAUTION ⚠

De-soldering should be done quickly (in about 5 seconds or less). The diodes will be damaged if heated for a longer time.

- For installation, reverse the order of removal.

[Inspection]

**(1) Continuity between leads**

- Check to ensure that there is continuity between each lead.
- If there is no continuity, the leads are open-circuited. Replace the stator assembly 16.

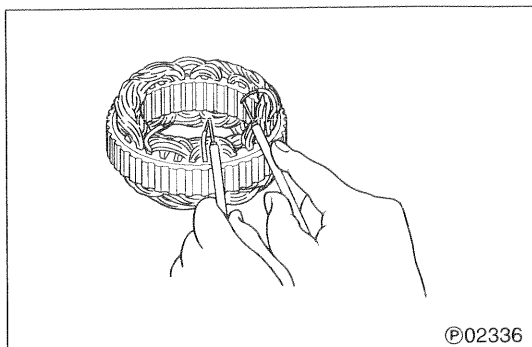

**(2) Continuity between each lead and core**

- Check to ensure that there is no continuity between each lead and the core.
- If there is continuity, it means a short circuit. Replace the stator assembly 16.

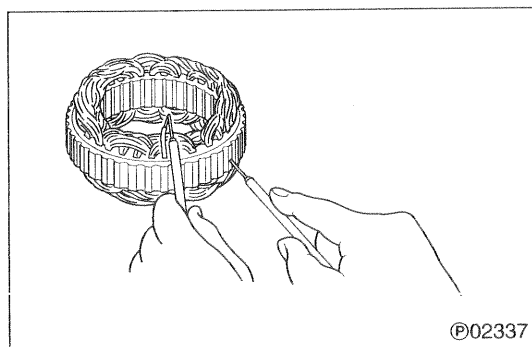

**18 Inspection of rectifier**

- Check the rectifier 18 to see if the internal diodes function properly, and replace if defective.

Resistance infinite in both cases...Open  
Resistance close to  $\Omega$  in both cases...Short

A, B, C: Leads of stator coil connected

D, F: Heat sink portion

E: Regulator connected

- Exchange the  $\oplus$  and  $\ominus$  sides of the tester and perform checks in both cases.

**CAUTION** 

When a tester is used for the checks, the current that flows out from the tester is feebler than the current that normally flows through the rectifier 18, so the tester may indicate a questionable resistance value. In a low range, this tendency will be stronger. Therefore, it is advisable to use the highest possible range.

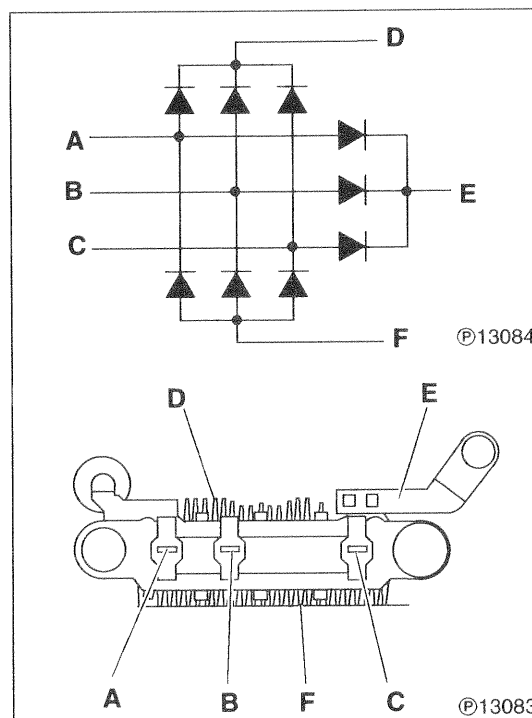

# STARTER <24V-5kW>

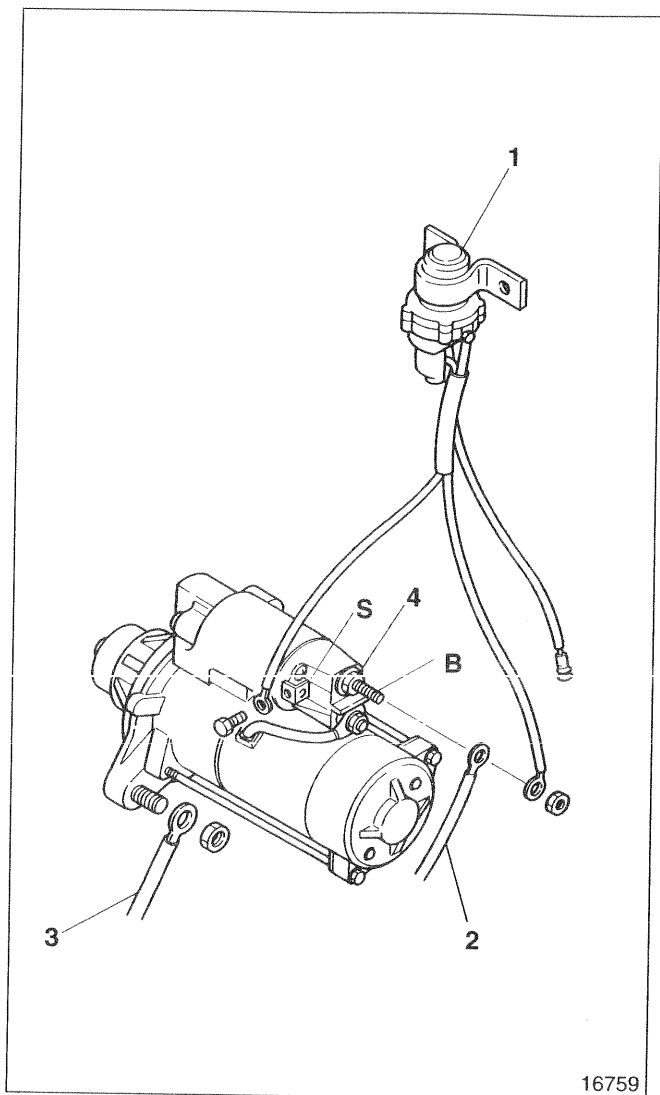

16759

## ● Removal sequence

- 1 Starter relay P.54-149
- 2 Battery cable  $\oplus$
- 3 Earth strap
- 4 Starter assembly P.54-110

B: Terminal B

S: Terminal S

## WARNING

Before removing the starter assembly 4, be sure to disconnect the negative  $\ominus$  terminal of the battery and insulate it with a tape or something else. If the negative  $\ominus$  terminal is not disconnected, the battery voltage is always available at each of terminals B and is dangerous.

## ● Installation sequence

Reverse the order of removal.

---

**M E M O**

---

# STARTER <24V-5kW>

## Starter Assembly

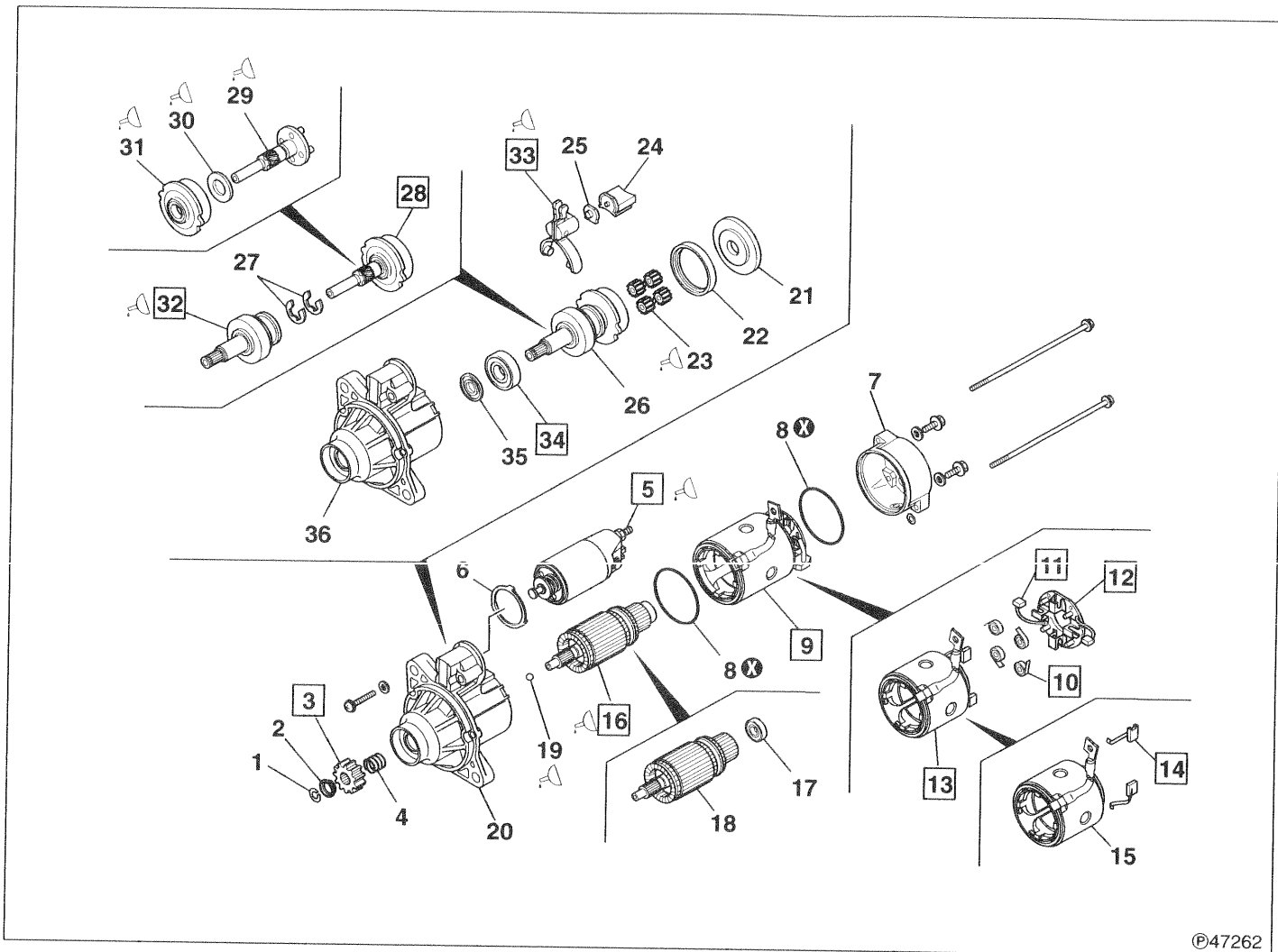

©47262

### ● Disassembly sequence

- |                                |  |                                       |
|--------------------------------|--|---------------------------------------|
| 1 Stopper ring                 | 15 Yoke                                    | 28 Gearshaft & Internal gear assembly |
| 2 Pinion stopper               | 16 Armature assembly                       | 29 Gearshaft assembly                 |
| 3 Pinion                       | 17 Rear bearing                            | 30 Washer                             |
| 4 Spring                       | 18 Armature                                | 31 Internal gear                      |
| 5 Magnet switch                | 19 Ball                                    | 32 Overrunning clutch                 |
| 6 Shim                         | 20 Front bracket assembly                  | 33 Lever assembly                     |
| 7 Rear bracket                 | 21 Cover                                   | 34 Front bearing                      |
| 8 Packing                      | 22 Packing                                 | 35 Oil seal                           |
| 9 Yoke & brush holder assembly | 23 Planetary gear                          | 36 Front bracket                      |
| 10 Brush spring                | 24 Packing                                 |                                       |
| 11 Brush ⊖                     | 25 Plate                                   |                                       |
| 12 Brush holder assembly       | 26 Gearshaft & overrunning clutch assembly | ⊗ : Non-reusable part                 |
| 13 Yoke assembly               | 27 E-ring                                  |                                       |
| 14 Brush ⊕                     |  |                                       |

**CAUTION** 

- Do not remove the bearings 17 and 34 unless defects are evident.
- When the armature assembly 16 is removed, the ball 19 might come out with it. Take care not to lose the ball.
- It is not necessary to remove the pinion 3 when only the motor should be removed and inspected for inspection of the brushes and the related parts.
- Be sure to remove the pinion 3 before disassembling any other parts.

**● Assembly sequence**

Follow the disassembly sequence in reverse.

**CAUTION** 

Whenever the magnetic switch 5 is replaced, the pinion gap must be adjusted.

**● Inspection after reassembly**

 P.54-112

**Service standards**

Unit: mm

Location	Maintenance item		Standard value	Limit	Remedy
—	Pinion gap		0.5 to 2.0	—	Adjust
—	No-load characteristics	During 23V supply	Current	85A or less	—
			Rotating speed	3300 rpm or more	
10	Spring pressure of brush spring		29 to 39 N {3 to 4 kgf}	20 N {2 kgf}	Replace
11, 14	Brush length		18	11	Replace
16	Outside diameter of commutator		32	31.4	Replace
	Commutator outer circumferential runout		—	0.05 or more	
	Depth of mica between segments		—	0.2 or less	Repair or replace

** Lubricant**

Location	Points of application	Specified lubricant	Quantity
5	Lever contact surface of magnetic switch	Multipurpose grease [NLGI No.2 (Li soap)]	As required
16	Teeth of armature assembly gear	MOLYKOTE ® AG650	As required
16, 29	Sliding surfaces of armature assembly and gear shaft assembly	MOLYKOTE ® AG650	As required
19	Ball	MOLYKOTE ® AG650	As required
23, 31	Teeth of planetary gear and internal gear	MOLYKOTE ® AG650	As required
29, 32	Sliding surfaces of gear shaft assembly and overrunning clutch	Multipurpose grease [NLGI No.2 (Li soap)]	As required
30	Washer	MOLYKOTE ® AG650	As required
32	Splines of overrunning clutch	Multipurpose grease [NLGI No.2 (Li soap)]	As required
33	Sliding surfaces of lever assembly and overrunning clutch	Multipurpose grease [NLGI No.2 (Li soap)]	As required

# STARTER <24V-5kW>

## ◆ Service procedure

### ● Inspection after reassembly

After reassembly, check the starter by supplying current.

### WARNING ⚠

- When current is supplied to the starter, the pinion 3 will spring out and rotate. Be careful not to touch it by hand.
- The magnet switch 5 may be very hot after the end of inspection. Be careful when you touch it.

### CAUTION ⚠

- The time during which current is supplied to the starter should be limited to 10 seconds or less on the pull-in coil P side and 30 seconds or less on the holding coil H side. If current is supplied to the coils for a longer period, the coils will be overheated and baked.
- When current is supplied to the starter, a large current that exceeds 100A will flow. When the starter is inspected, therefore, use thick cables like booster cables. Check to ensure that all the connections are tight and secure.

### (1) Performance test

- Wire the starter as shown.

A: Ammeter

D: DC power supply

B: Starter terminal B

S: Starter terminal S

C: Switch

V: Voltmeter

- Set the voltage at 23V DC.

### CAUTION ⚠

The voltage that is applied should be limited to 24V maximum.

- The following operations are performed by supplying current to the starter. It is therefore necessary that the series of operations ranging from measuring the current that flows through the starter to measuring the rotating speed are completed in less than 30 seconds.
  - Set the switch C to ON to supply current to the starter. At the time, the pinion 3 will spring out and rotate.

### CAUTION ⚠

When the switch C is set to ON, current is supplied to both the pull-in coil P and holding coil H. When the large current from the DC power supply D is supplied from terminal B of the starter to terminal M, the current to the pull-in coil is interrupted, and current flows to the holding coil only.

To prevent baking the holding coil, therefore, all the operations must be completed in less than 30 seconds.

- Measure the current and rotating speed of the starter. Measure the rotating speed of the starter by illuminating the pinion 3 with a stroboscope.
- Set the switch C to OFF to stop supplying current to the starter.
- If the reading is out of the standard value, disassemble and check the starter.

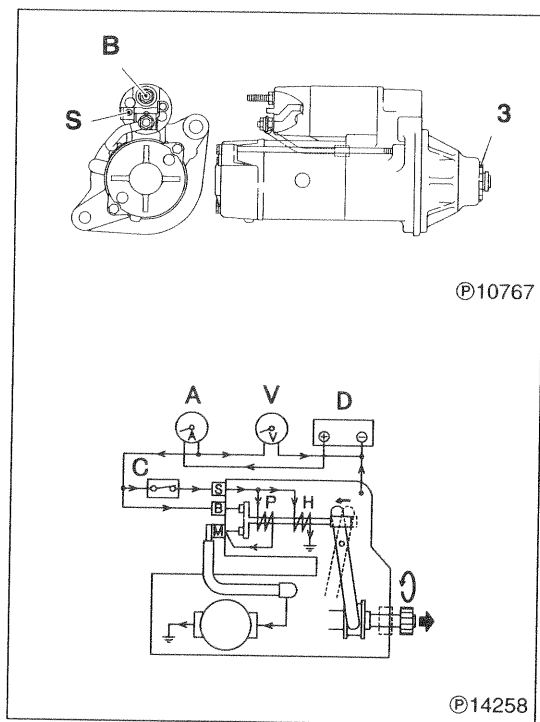
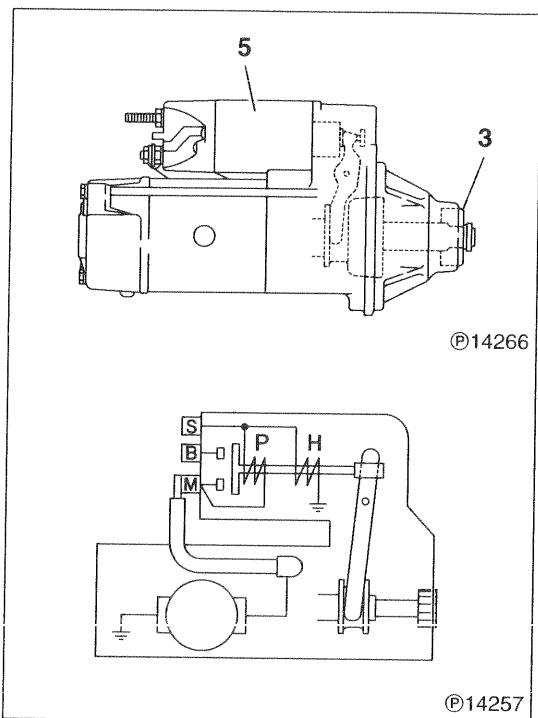

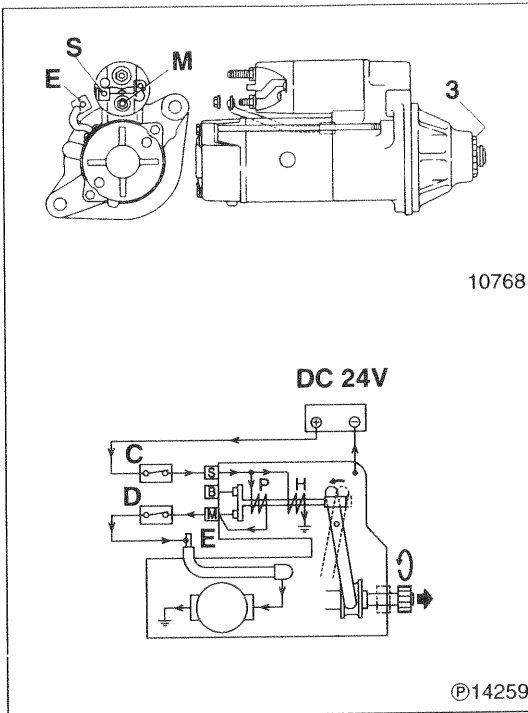

## (2) Pinion gap

[Inspection]

- Wire the starter as shown.

C: Switch

D: Switch

E: Cable

M: Starter terminal M

S: Starter terminal S

- The following operations are performed by supplying current to the starter. It is therefore necessary that the series of operations up to completion of measurement of the pinion gap is completed in less than 30 seconds.
- Set the switch C and switch D to ON to supply current to the starter. At the time, the pinion 3 will spring out and rotate.

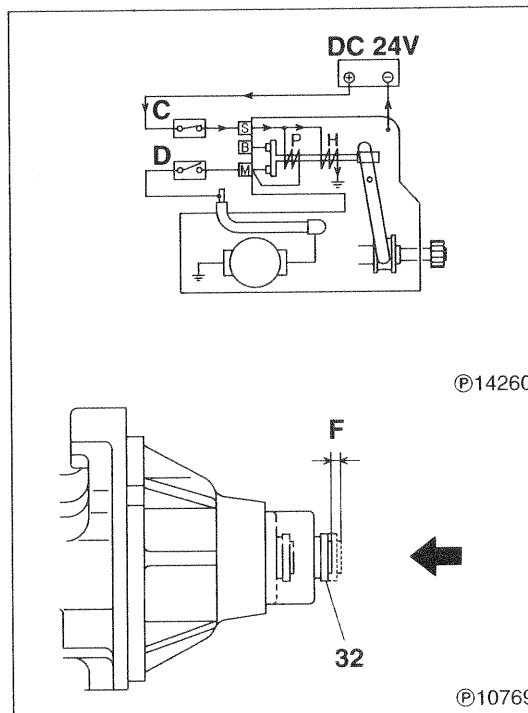

- Immediately (in less than 5 seconds) after the pinion has started rotation, set the switch D to OFF to stop rotation of the pinion.

### CAUTION

When the switch C and switch D are set to ON, current is supplied to both the pull-in coil P and holding coil H. Since wiring is such that no voltage is applied to terminal B of the starter, current flows to the pull-in coil during rotation of the pinion 3. To prevent baking the pull-in coil, therefore, it is necessary that the switch E is set to OFF immediately (in less than 5 seconds) after the pinion has started rotating.

- Pull out the overrunning clutch 32 by hand, then push back its end lightly and measure the amount F the clutch moves in the axial direction (pinion gap).
- Set the switch C to OFF to stop supplying current to the starter.
- If the reading is out of the standard value, replace the lever assembly 33.

# STARTER <24V-5kW>

## 3 Pinion

[Removal]

To remove the pinion 3, it is necessary to supply current to the starter and let the pinion spring out.

### WARNING

- When current is supplied to the starter, the pinion 3 will spring out and rotate. Be careful not to touch it by hand.
- The magnet switch assembly 5 may be very hot after the end of inspection. Be careful when you touch it.

### CAUTION

- The time during which current is supplied to the starter should be limited to 10 seconds or less on the pull-in coil P side and 30 seconds or less on the holding coil H side. If current is supplied to the coils for a longer period, the coils will be overheated and baked.
- Make sure that the pinion 3 is made to spring out by supplying current to the starter. If the pinion is forced out by pulling the lever assembly 33 without supplying current to the starter, the front bracket 36 and lever could be damaged by the impact produced when the stopper ring 1 is removed.
- When current is supplied to the starter, a large current that exceeds 100A will flow. When the starter is inspected, therefore, use thick cables like booster cables. Check to ensure that all the connections are tight and secure.

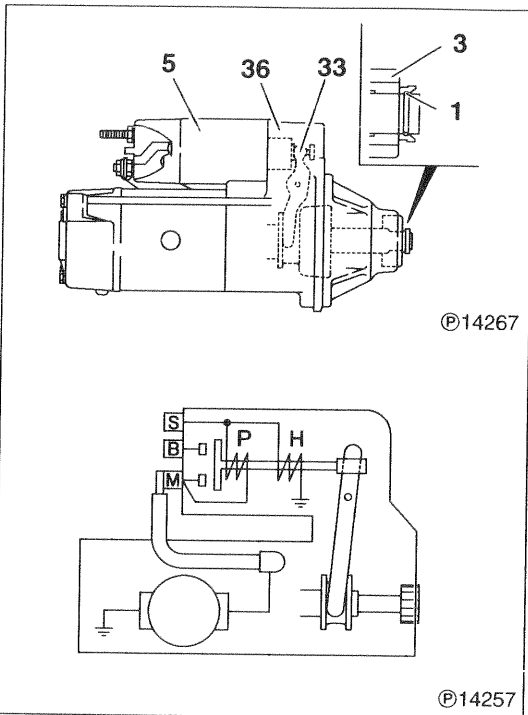

- Wire the starter as shown.

- A: Switch
- C: Switch
- D: Cable
- M: Starter terminal M
- S: Starter terminal S

- The following operations are performed by supplying current to the starter. It is therefore necessary that the series of operations up to removal of the pinion 3 is completed in less than 30 seconds.
  - Set the switch A and switch C to ON to supply current to the starter. At the time, the pinion 3 will spring out and rotate.

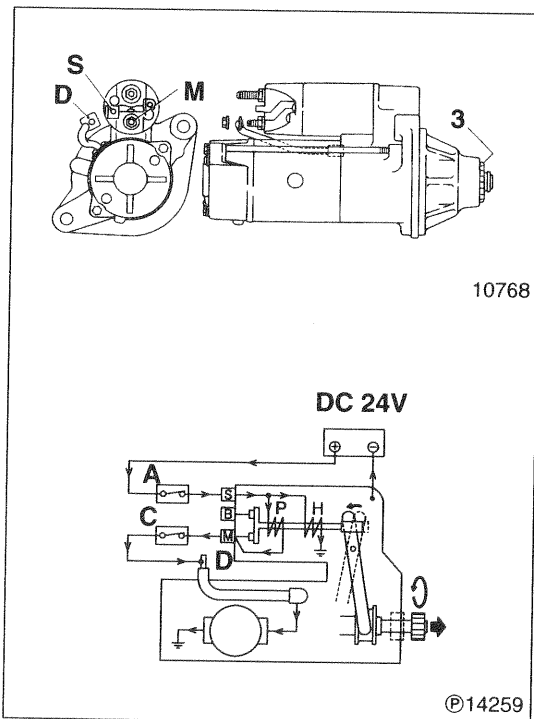

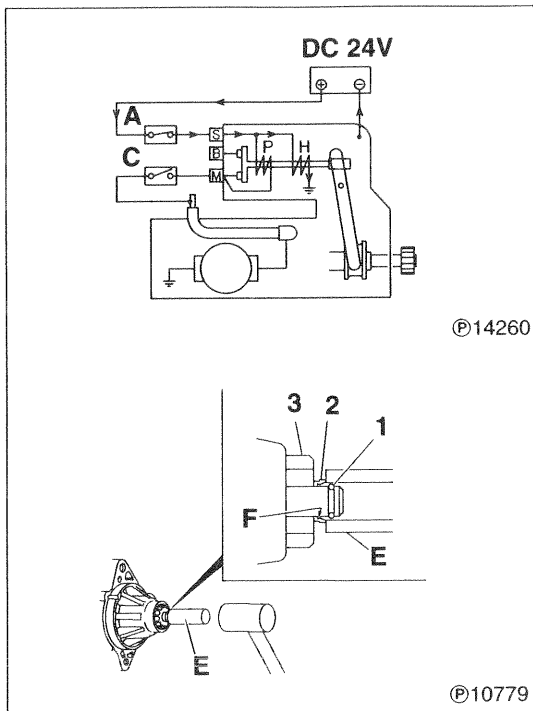

- Immediately (in less than 5 seconds) after the pinion 3 has started rotating, set the switch C to OFF to stop rotation of the pinion.

### CAUTION

When the switch A and switch C are set to ON, current is supplied to both the pull-in coil P and holding coil H. Since wiring is such that no voltage is applied to terminal B of the starter, current flows to the pull-in coil during rotation of the pinion 3.

To prevent baking the pull-in coil, therefore, it is necessary that the switch C is set to OFF immediately (in less than 5 seconds) after the pinion has started rotating.

- Set the pipe-like tool E on the pinion stopper 2.
- Lightly strike the tool E with a hammer to remove the stopper ring 1 from the ring groove F of the pinion stopper 2.
- Remove the stopper ring 1 and remove the pinion 3.
- Set the switch A to OFF to stop supplying current to the starter.

### CAUTION

When the power supply to the starter is stopped, the pinion 3 may move in and the stopper ring 1 may fit in the ring groove F of the pinion stopper 2 again.

In this case, repeat the operations by supplying current to the starter.

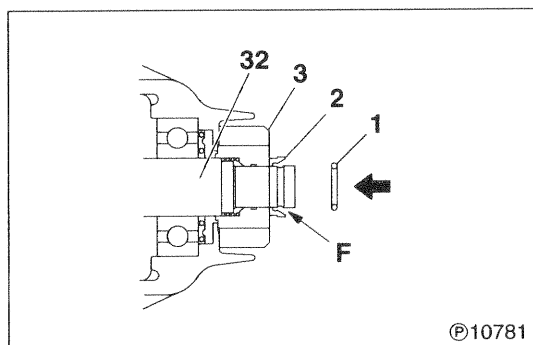

### [Installation]

To install the pinion 3, it is not necessary to supply current to the starter.

- Install the pinion stopper 2 and pinion 3 on the overrunning clutch 32 in the direction shown.
- Set the stopper ring 1 in the ring groove F of the overrunning clutch 32.

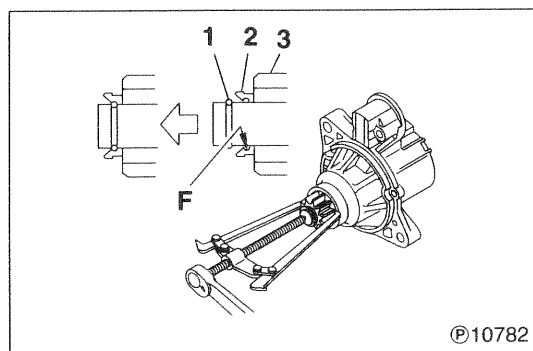

- Pull the pinion 3 strongly to make sure that the stopper ring 1 securely fits in the ring groove F of the pinion stopper 2.

# STARTER <24V-5kW>

## 5 Magnet switch

[Installation]

Install the magnet switch 5 on the lever assembly 33 with terminal S in the direction shown.

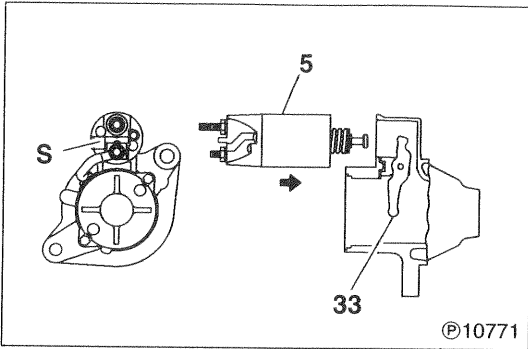

[Inspection]

### (1) Open circuit test on coil

- Check to ensure that there is continuity between terminals S and M.
- If there is no continuity, replace the magnet switch 5.

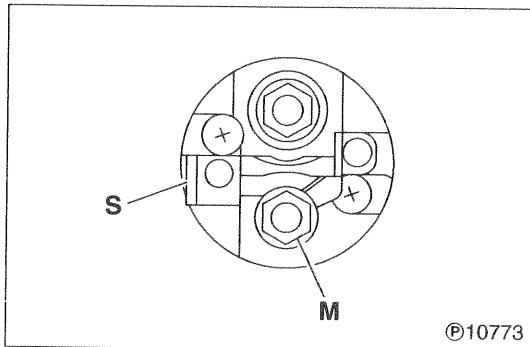

- Check to ensure that there is continuity between terminal M and body A.
- If there is no continuity, replace the magnet switch 5.

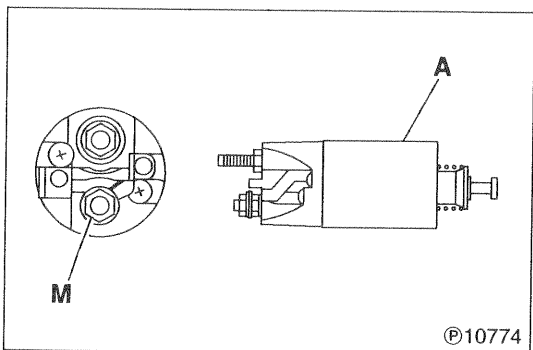

### (2) Contact fusion check

- Check to ensure that there is no continuity between terminals B and M.
- If there is continuity, replace the magnet switch 5.

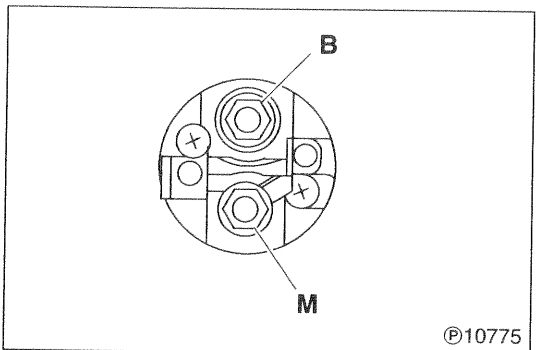

### (3) Contact contacting check

- Push the end of the magnet switch 5 in to close the internal contact. In this state, check to ensure that there is continuity between terminals B and M.
- If there is no continuity, replace the magnet switch 5.

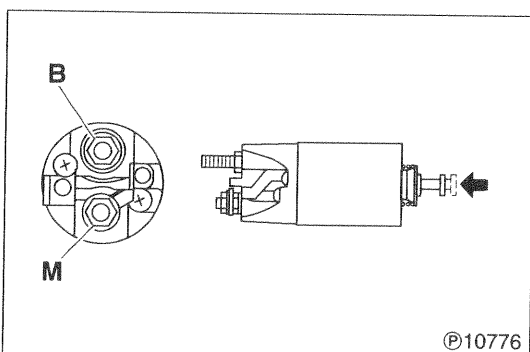

### 9 Removal of yoke & brush holder assembly

To remove the yoke & brush holder assembly 9, proceed as described below, while using care to prevent damage to the commutator A of the armature assembly 16 by the brushes 11 and 14.

- Keep the brushes 11 and 14 apart from the commutator A and hold the brush spring 10 alongside the brushes.

- Remove the yoke & brush holder assembly 9 from the front bracket assembly 20.

**CAUTION**  \_\_\_\_\_  
When the yoke & brush holder assembly 9 is removed, do not tilt it downward. Otherwise, the armature assembly 16 may fall down.

- For installation, reverse the order of removal.

### 10 Inspection of brush spring

- Use new brushes 11 and 14 and measure the load at the moment the brush spring 10 leaves the brushes as shown.
- If the reading is less than the limit, replace the brush spring 10.

### 11 14 Inspection of brush

#### (1) Length of brush

If the reading is less than the limit, replace the brushes 11 and 14.

**CAUTION**  \_\_\_\_\_  
To replace the brush  $\ominus$  11, replace the brush holder assembly 12.

#### (2) Commutator contacting surfaces

If the contacting surfaces are rough or unevenly worn, repair with emery paper (#300 to 500).

### 12 Inspection of brush holder assembly

- Check to ensure that there is no continuity between the  $\oplus$  side brush holder and  $\ominus$  side holder plate.
- If there is continuity, it means a short circuit. Replace the brush holder assembly 12.

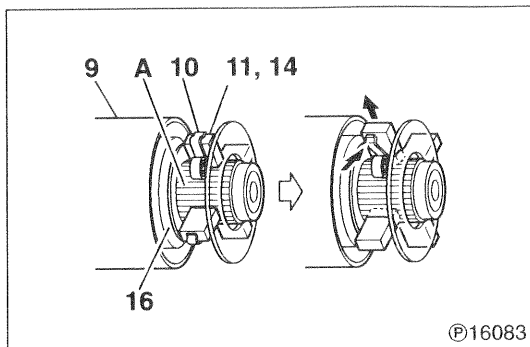

©16083

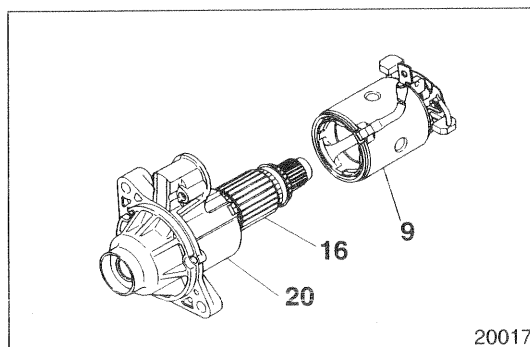

20017

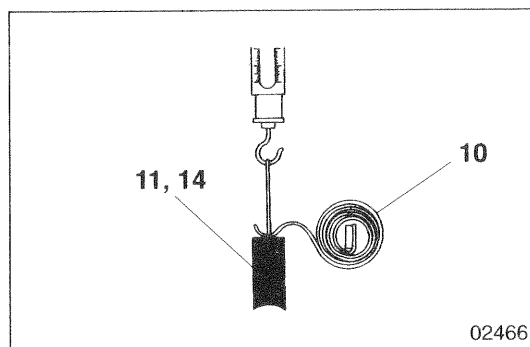

02466

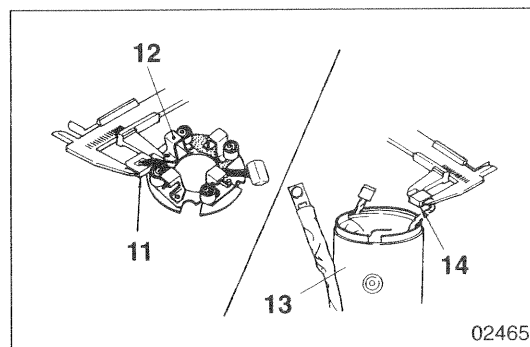

02465

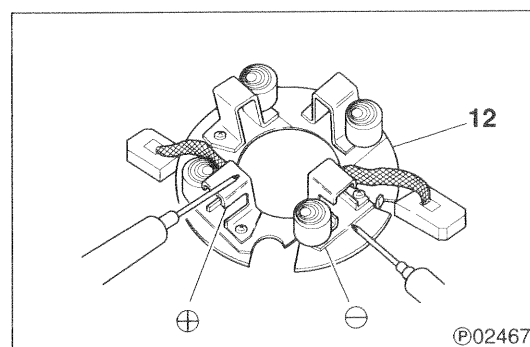

©02467

# STARTER <24V-5kW>

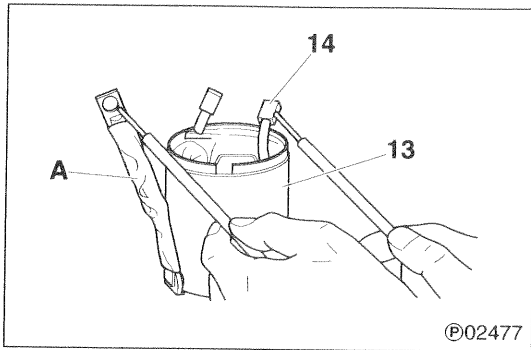

## 13 Inspection of yoke assembly

### (1) Open circuit test on coil

- Check to ensure that there is continuity between cable **A** and brush ⊕ **14**.
- If there is no continuity, it means an open circuit. Replace the brush ⊕ **14** or yoke assembly **13**.

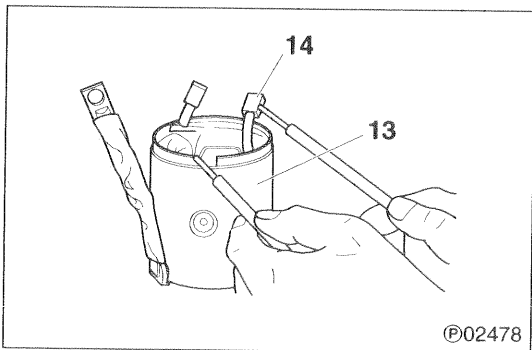

### (2) Earth test on coil

- Check to ensure that there is no continuity between the yoke assembly **13** and brush ⊕ **14**.
- If there is continuity, it means a short circuit. Check the insulation. If repair is impossible, replace the brush ⊕ **14** or yoke assembly **13**.

### CAUTION ⚠

The coil may be short-circuited to the yoke assembly **13** due to the accumulation of worn-off metal particles from the brushes and/or armature.

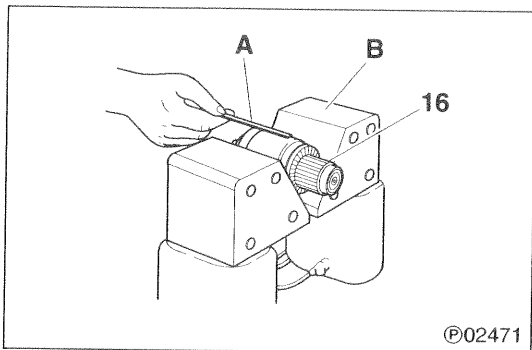

## 16 Inspection of armature assembly

### (1) Short circuit test on coil

- Bring the iron piece **A** close to the armature assembly **16**, keeping it in parallel.

**B**: Armature tester

- Slowly rotate the armature assembly **16** by hand.
- If the iron piece **A** is attracted or vibrates, it means a short circuit. Replace the armature assembly **16**.

### (2) Earth test on coil

- Check to ensure that there is no continuity between the commutator **C** and core **D** (or shaft portion **E**).
- If there is continuity, it means a short circuit. Replace the armature assembly **16**.

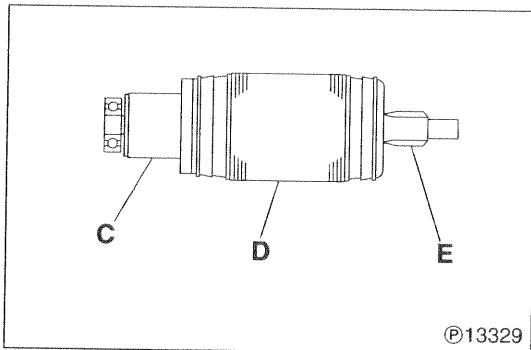

### (3) Runout of commutator

If the reading is more than the limit, repair the outside diameter of the commutator portion **C** of the armature assembly **16** within the limit.

### (4) Condition of commutator surface

- If the surface is rough or unevenly worn, repair with emery paper (#300 to 500).
- After the repair, be sure to check the runout of the commutator portion **C**.

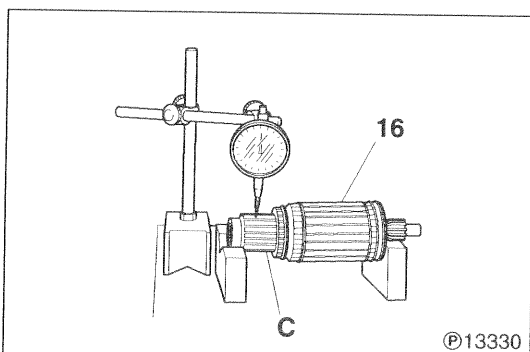

**(5) Outside diameter of commutator**

If the reading is more than the limit, replace the armature assembly 16.

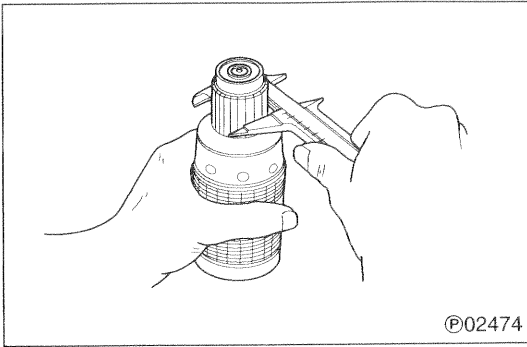
**(6) Depth of mold between segments**

Before inspection, clean the mold portions.

- If the reading is less than the limit, repair or replace the armature assembly 16.

F: Depth of mold

- Make repairs by grinding the illustrated portion G.

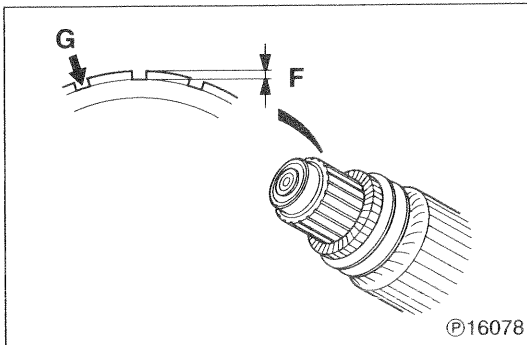

- If the mold portion is as shown, repair or replace the armature assembly 16.

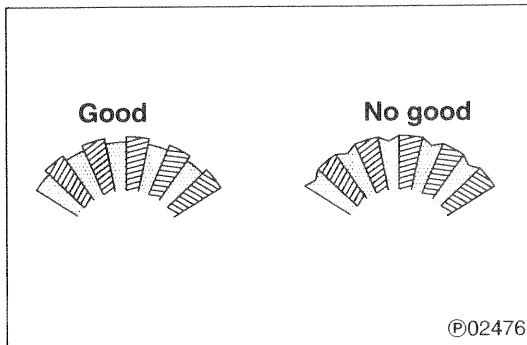
**28 Removal of gear shaft and internal gear assembly**

Remove the E-rings 27 and then the gear shaft and internal gear assembly 28 from the overrunning clutch 32.

Proceed as follows if the assembly 28 cannot be removed due to interference of the splined section A of gear shaft assembly 29 with internal parts of the overrunning clutch.

- Press the gear shaft assembly 29 against the overrunning clutch 32.
- Turn the gear shaft assembly 29 approx. 1/8 of a turn to change the position of splined section A.

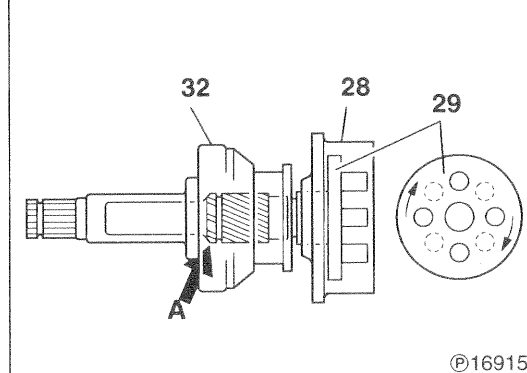
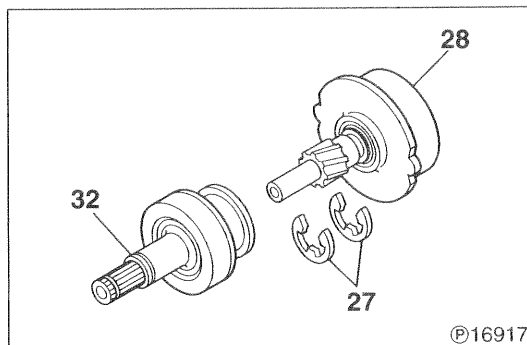

# STARTER <24V-5kW>

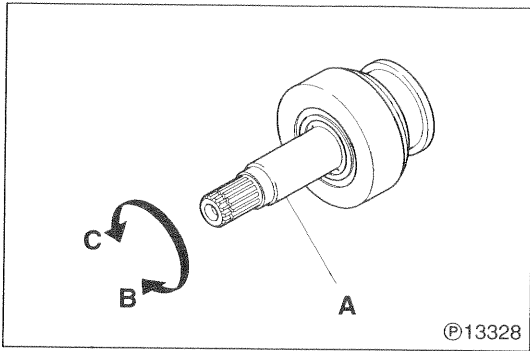

## 32 Inspection of overrunning clutch

Perform the following checks. If there is anything wrong, replace the over-running clutch 32.

- Check to ensure that when the shaft **A** is made to rotate in the direction **B**, it rotates smoothly.
- Check to ensure that when the shaft **A** is made to rotate in the direction **C**, it is locked.

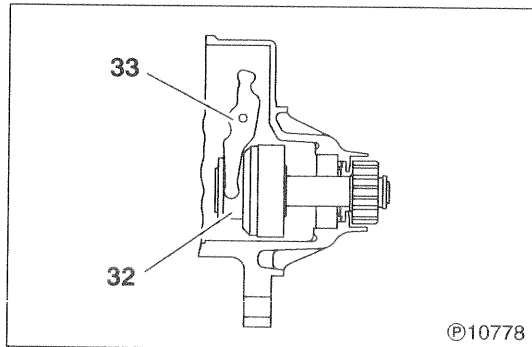

## 33 Installation of lever assembly

Install the lever assembly 33 in the illustrated direction on the overrunning clutch 32.

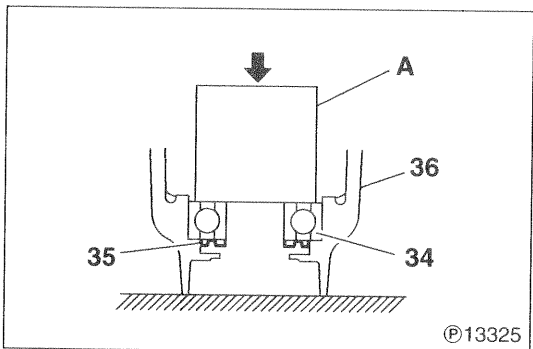

## 34 Installation of front bearing

- Before the front bearing 34 is press-fitted, install the oil seal 35.
- Press-fit the front bearing 34 in the front bracket 36 with a press, using the pipe-like tool A.

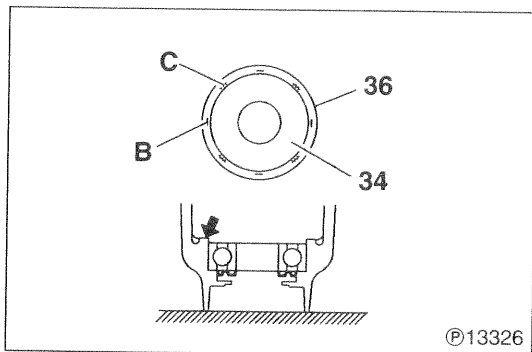

- Stake the front bracket 36 side.

**CAUTION** ⚠ \_\_\_\_\_  
Avoid staking the previously staked points B.

C: Staking points (4 places)

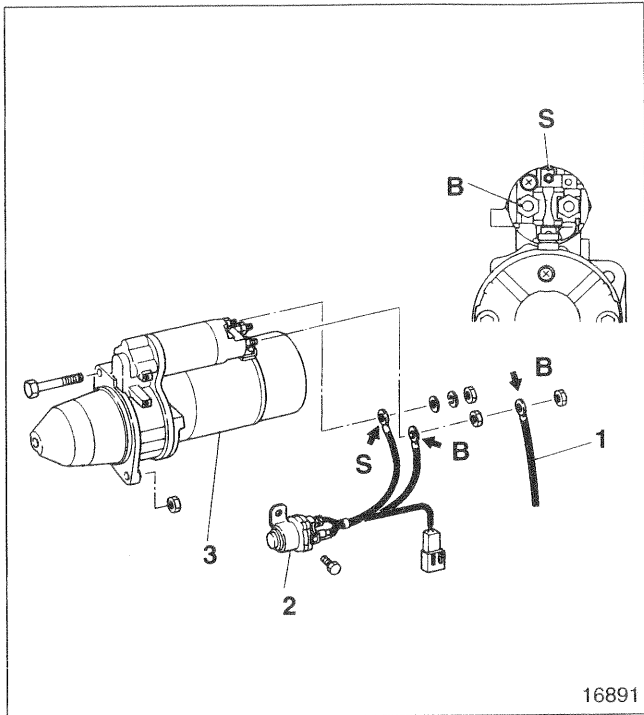

● Removal sequence

- 1 Starter cable ⊕
- 2 Starter relay P.54-149
- 3 Starter assembly P.54-124

B: Terminal B  
S: Terminal S

**WARNING** ⚠

Before removing the starter assembly 3, be sure to disconnect the negative ⊖ terminal of the battery and insulate it with a tape or something else. If the negative ⊖ terminal is not disconnected, the battery voltage is always available at each of terminals B and is dangerous.

● Installation sequence

Reverse the order of removal.

# STARTER <24V-6kW>

## Starter Assembly

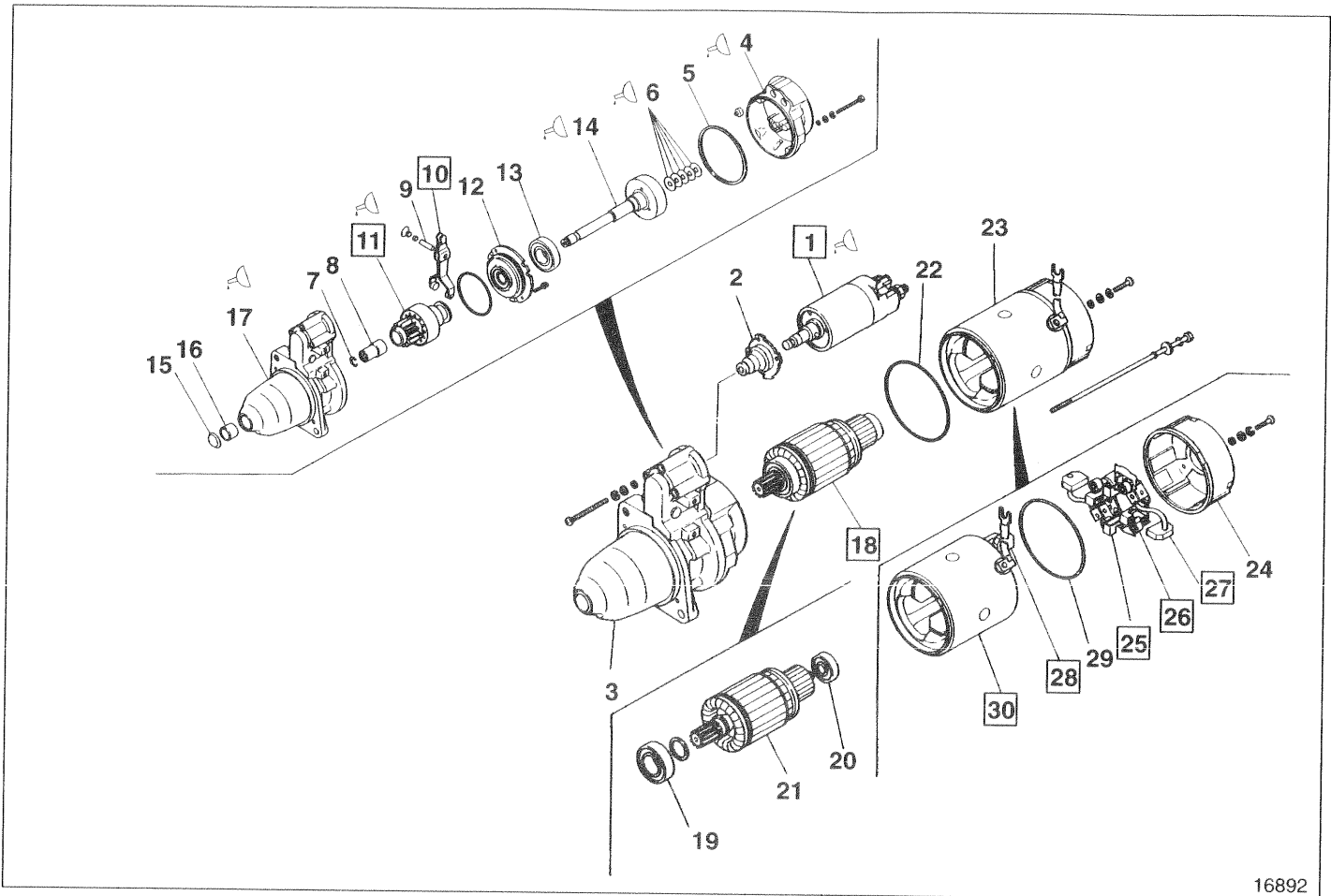

16892

### ● Inspection before disassembly

📖 P.54-124

### ● Disassembly sequence

- |                          |                       |                                 |
|--------------------------|-----------------------|---------------------------------|
| 1 Magnet switch          | 11 Overrunning clutch | 21 Armature                     |
| 2 Cover                  | 12 Gear bracket       | 22 Packing                      |
| 3 Front bracket assembly | 13 Gearshaft bearing  | 23 Yoke & rear bracket assembly |
| 4 Center bracket         | 14 Gearshaft          | 24 Rear bracket                 |
| 5 Packing                | 15 Cover              | 25 Brush holder assembly        |
| 6 Adjusting washer       | 16 Sleeve bearing     | 26 Brush spring                 |
| 7 Stopper ring           | 17 Front bracket      | 27 Brush ⊖                      |
| 8 Pinion stopper         | 18 Armature assembly  | 28 Brush ⊕                      |
| 9 Pin                    | 19 Front bearing      | 29 Packing                      |
| 10 Lever                 | 20 Rear bearing       | 30 Yoke assembly                |

### CAUTION ⚠

- Do not remove the bearings 13, 16, 19 and 20 unless they are found to be defective.
- When the yoke & rear bracket assembly 23 is removed from the front bracket assembly 3, be careful not to allow the armature assembly 18 to fall.

### ● Reassembly sequence

Reverse the order of disassembly.

### NOTE

When the magnet switch 1 was replaced, be sure to adjust the pinion gap.

### ● Inspection after reassembly

📖 P.54-124

### Service standards

Unit: mm

Location	Maintenance item		Standard value	Limit	Remedy
—	Thrust gap of gearshaft assembly		0.1 to 0.5	—	Adjust
—	Pinion gap		0.5 to 4.0	—	Adjust
—	No-load characteristics (During 23.5V supply)	Current	110A or less	—	Check
		Rotating speed	3,300 rpm or more	—	
18	Armature assembly	Outside diameter of commutator	43.2	42.6	Replace
		Runout of outer circumference of commutator	0 to 0.03	0.1	Replace
		Depth of mica between segments	0.4 to 0.6	0.2 or less	Replace
26	Spring pressure of brush spring		25 to 34 N {2.55 to 3.45 kgf}	18 N {1.8 kgf}	Replace
27, 28	Brush length		23	14	Replace

### 🔧 Lubricant

Location	Points of application	Specified lubricant	Quantity
1	Apply to lever contacting portion of magnet switch.	Multipurpose grease [NLGI No.2 (Li soap)]	As required
4	Apply to gear shaft mounting section of center bracket	Multipurpose grease [NLGI No.2 (Li soap)]	As required
6	Apply to adjusting washer	Multipurpose grease [NLGI No.2 (Li soap)]	As required
11	Apply to lever sliding surfaces of overrunning clutch	Multipurpose grease [NLGI No.2 (Li soap)]	As required
14	Apply to clutch splined portion of gear shaft	Multipurpose grease [NLGI No.2 (Li soap)]	As required
	Apply to internal gear of gearshaft	Multipurpose grease [NLGI No.2 (Li soap)]	As required
17	Greasing portion at end of front bracket	Multipurpose grease [NLGI No.2 (Li soap)]	As required

# STARTER <24V-6kW>

## ◆ Service procedure

### ● Inspection before disassembly

#### Thrust gap of gearshaft 14

[Inspection]

- Measure the thrust gap of the gearshaft 14.
- If the reading is out of the standard value, adjust by the following procedures.

[Adjustment]

- Remove the center bracket 4 from the front bracket assembly 3.
- Adjust by changing the thickness of adjust washer 6.

Types of adjust washers: 0.25, 0.5 mm

### ● Inspection after reassembly

After reassembly of the starter, check the starter by supplying current.

#### WARNING ⚠

- When current is supplied to the starter, the pinion C will spring out and rotate. Be careful not to touch it by hand.
- The magnet switch 1 may become very hot during inspection. Be careful when you touch it.

#### CAUTION ⚠

- The time during which current is supplied to the starter should be limited to 10 seconds or less on the pull-in coil P side and 30 seconds or less on the holding coil H side. If current is supplied to the coils for a longer period, the coils will be overheated and baked.
- When current is supplied to the starter, a large current that exceeds 100A will flow. When the starter is inspected, therefore, use thick cables like booster cables. Check to ensure that all the connections are tight and secure.

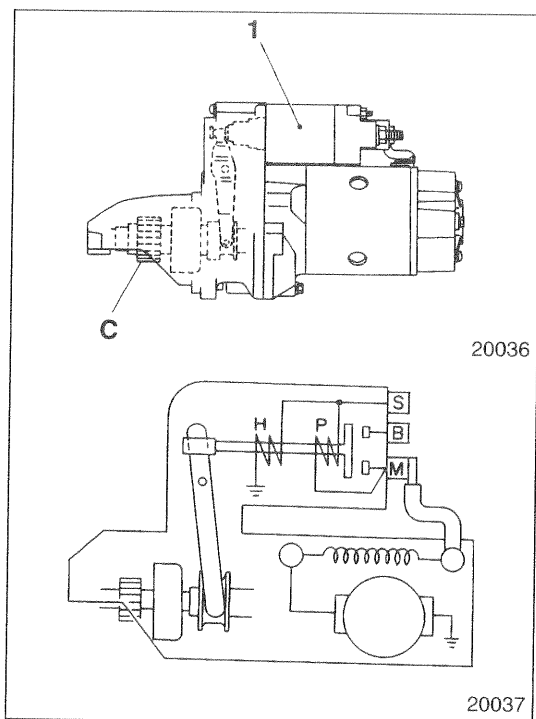
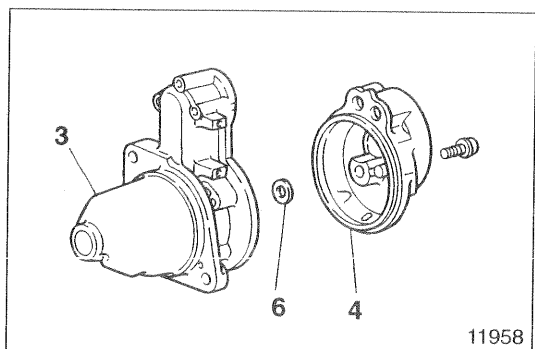
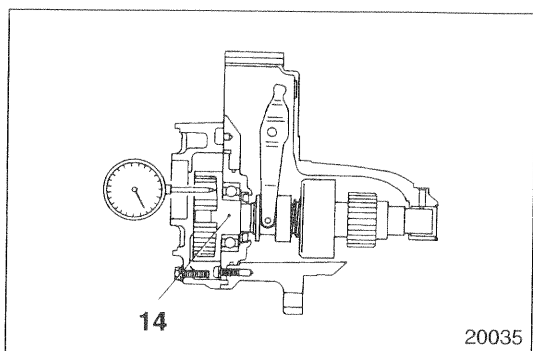

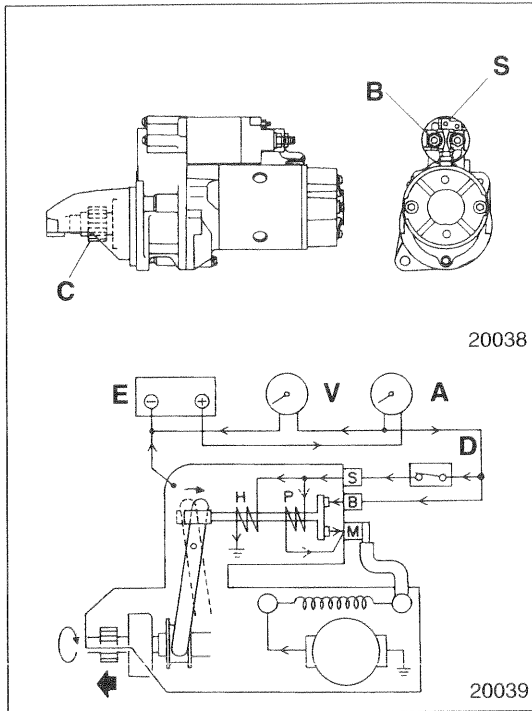

### (1) Performance test

- Wire the starter as shown.

**A:** Ammeter  
**B:** Starter terminal B  
**D:** Switch  
**E:** DC power supply  
**S:** Starter terminal S  
**V:** Voltmeter

- Set the voltage at 23.5V DC.

**CAUTION** ⚠ \_\_\_\_\_  
 The voltage that is applied should be limited to 24V maximum.

- The following operations are performed by supplying current to the starter. It is therefore necessary that the series of operations ranging from measuring the current that flows through the starter to measuring the rotating speed are completed in less than 30 seconds.
- Set the switch **D** to ON to supply current to the starter. At the time, the pinion **C** will spring out and rotate.

**CAUTION** ⚠ \_\_\_\_\_  
 When the switch **D** is set to ON, current is supplied to both the pull-in coil **P** and holding coil **H**. When the large current from the DC power supply **E** is supplied from terminal **B** of the starter to terminal **M**, the current to the pull-in coil is interrupted, and current flows to the holding coil only.  
 To prevent baking the holding coil, therefore, all the operations must be completed in less than 30 seconds.

- Measure the current and rotating speed of the starter. Measure the rotating speed of the starter by illuminating the pinion **C** with a stroboscope.
- Set the switch **D** to OFF to stop supplying current to the starter.
- If the reading is out of the standard value, disassemble and check the starter.

# STARTER <24V-6kW>

## (2) Pinion gap

[Inspection]

- Wire the starter as shown.

D: Switch

E: 24V DC

F: Switch

G: Connector

M: Starter terminal M

S: Starter terminal S

- The following operations are performed by supplying current to the starter. It is therefore necessary that the series of operations up to completion of measurement of the pinion gap is completed in less than 30 seconds.
- Set the switch **D** and switch **F** to ON to supply current to the starter. At the time, the pinion **C** will spring out and rotate.

- Immediately (in less than 5 seconds) after the pinion has started rotation, set the switch **F** to OFF stop rotation of the pinion.

### CAUTION

When the switch **D** and switch **F** are set to ON, current is supplied to both the pull-in coil **P** and holding coil **H**. Since wiring is such that no voltage is applied to terminal **B** of the starter, current flows to the pull-in coil during rotation of the pinion **C**. To prevent baking the pull-in coil, therefore, it is necessary that the switch is set to OFF immediately (in less than 5 seconds).

- Lightly push the end of the pinion **C** in and measure the amount **J** the clutch moves in the axial direction (pinion gap).

### NOTE

When the pinion is strongly pushed, the pinion moves back, while compressing the spring.

- Set the switch **D** to OFF to stop supplying current to the starter.
- If the reading is out of the standard value, it means that the starter has been incorrectly reassembled. Therefore, repeat disassembly and reassembly.

## 1 Magnet switch

[Installation]

Install the magnet switch **1** in the illustrated direction on the lever **10**.

S: Terminal S

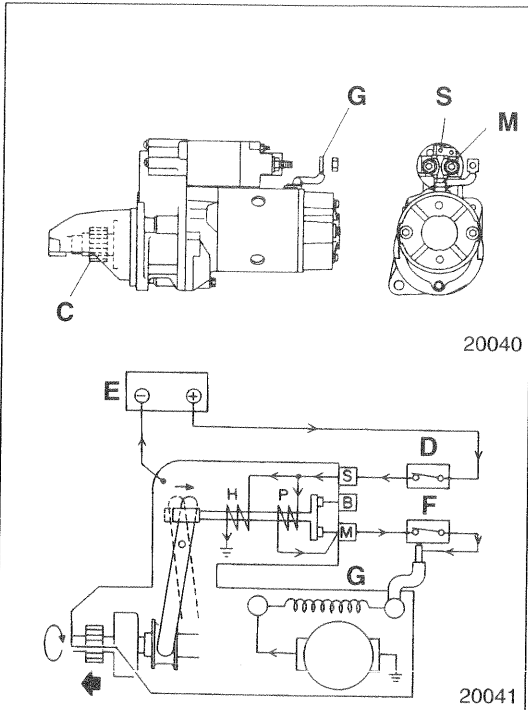

20040

20041

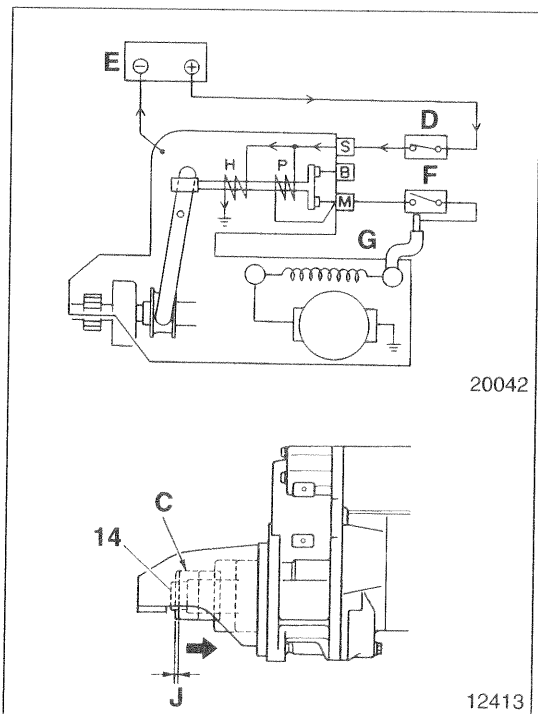

20042

12413

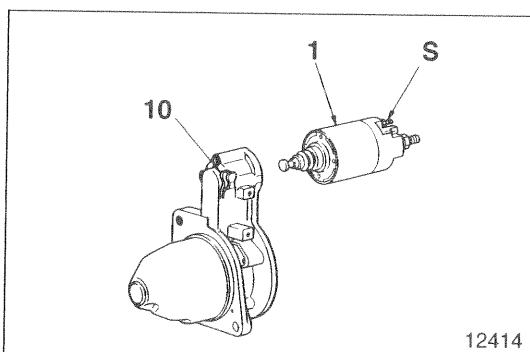

12414

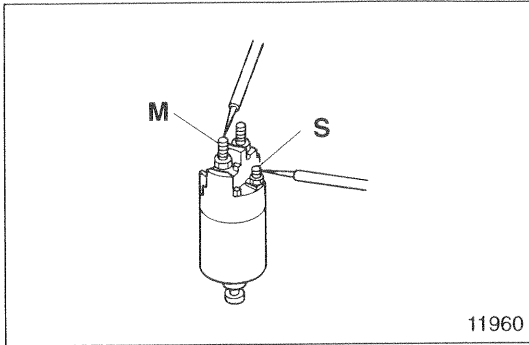

[Inspection]

**(1) Open circuit test on coil**

- Check to ensure that there is continuity between terminals S and M.
- If there is no continuity, replace the magnet switch **1**.

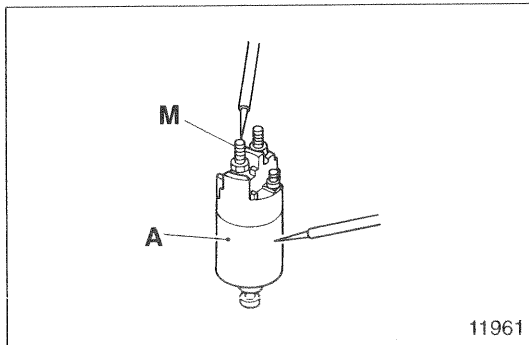

- Check to ensure that there is continuity between terminal M and body A.
- If there is no continuity, replace the magnet switch **1**.

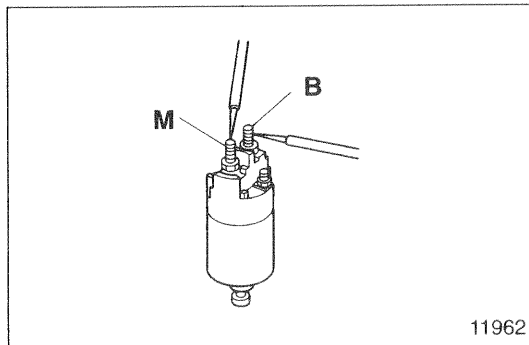

**(2) Contact fusion check**

- Check to ensure that there is no continuity between terminals B and M.
- If there is continuity, replace the magnet switch **1**.

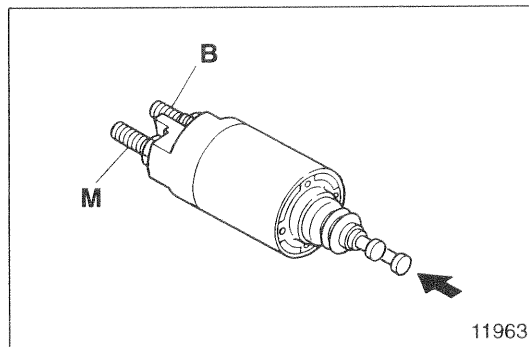

**(3) Contact contacting check**

- Strongly push the end of the magnet switch **1** in to close the internal contact. In this state, check to ensure that there is continuity between terminals B and M.
- If there is no continuity, replace the magnet switch **1**.

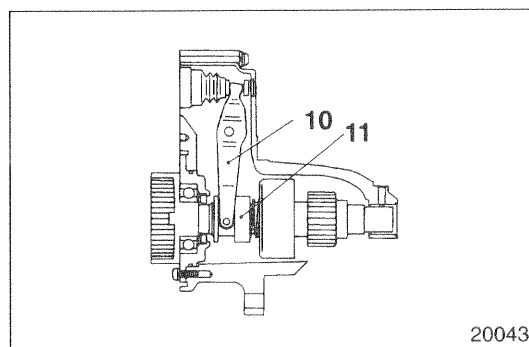

**10** Installation of lever

Install the lever **10** in the illustrated direction on the overrunning clutch **11**.

# STARTER <24V-6kW>

## 11 Overrunning clutch

[Removal]

- Set the pipe-like tool **A** on the pinion stopper **8**.
- Lightly strike the tool **A** with a hammer to remove the pinion stopper **8** from the stopper ring **7**.
- Remove the stopper ring **7** from the gearshaft **14** and withdraw the pinion stopper **8**.

[Inspection]

- Check to ensure that the pinion **B** of the overrunning clutch **11** rotates in the direction **C** and does not rotate in the direction **D**.
- If there is anything wrong, replace the overrunning clutch **11**.

[Installation]

- Install the pinion stopper **8** in the illustrated direction on the gearshaft **14**.

- Install the stopper ring **7** in the ring groove **E** of the gearshaft **14**.

- Strongly pull the pinion gear **F** to securely mount the pinion stopper **8** in the stopper ring **8**.

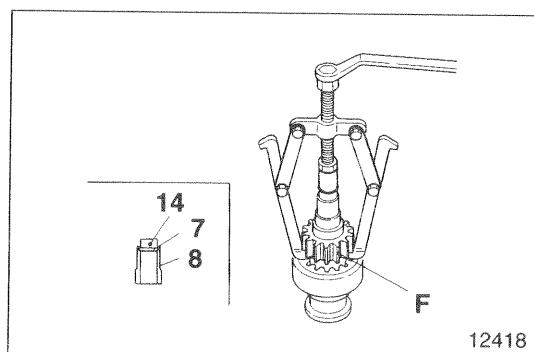
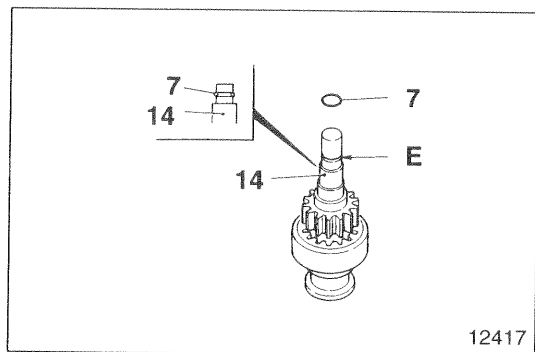
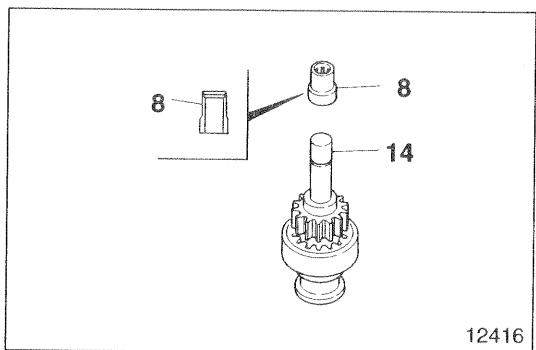
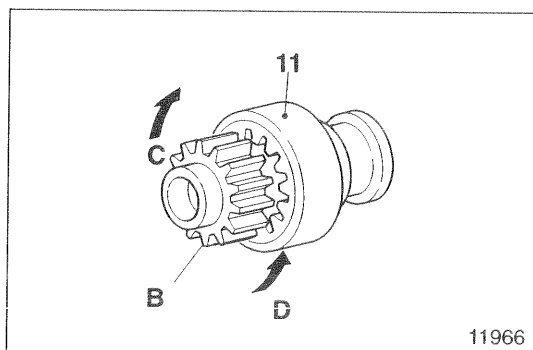
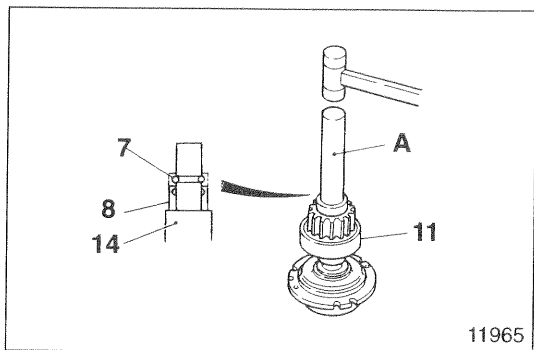

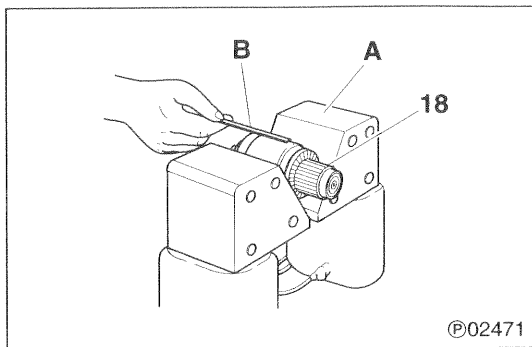

## 18 Inspection of armature assembly

### (1) Short circuit test on coil

- Bring the iron piece **B** close to the armature assembly **18**, keeping it in parallel.

**A:** Armature tester

- Slowly rotate the armature assembly **18** by hand.
- If the iron piece **B** is attracted or vibrates, it means a short circuit. Replace the armature assembly **18**.

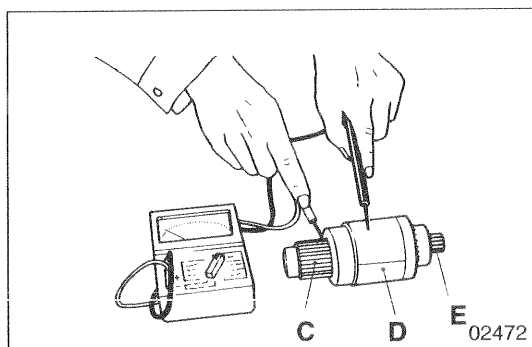

### (2) Earth test on coil

- Check to ensure that there is no continuity between the commutator **C** and core **D** (or shaft portion **E**).
- If there is continuity, it means a short circuit. Replace the armature assembly **18**.

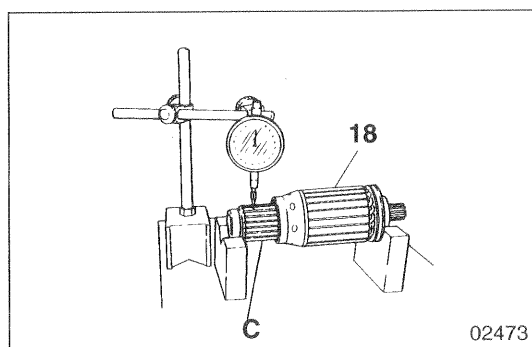

### (3) Runout of commutator

If the reading is more than the limit, repair the outside diameter of the commutator portion **C** of the armature assembly **18** within the limit.

### (4) Roughness of commutator surface

- If the surface is rough or unevenly worn, repair with emery paper (#300 to 500).
- After the repair, be sure to check the runout of the commutator portion **C**.

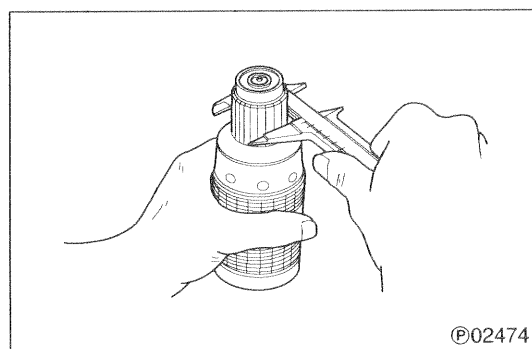

### (5) Outside diameter of commutator

If the reading is more than the limit, replace the armature assembly **18**.

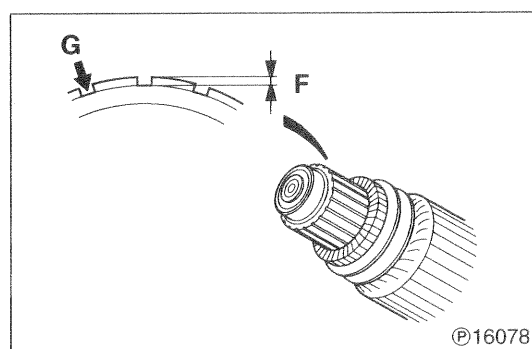

### (6) Depth of mold between segments

Before inspection, clean the mold portions.

- If the reading is less than the limit, repair or replace the armature assembly **18**.

**F:** Depth of mold

- Make repairs by grinding the illustrated portion **G**.

# STARTER <24V-6kW>

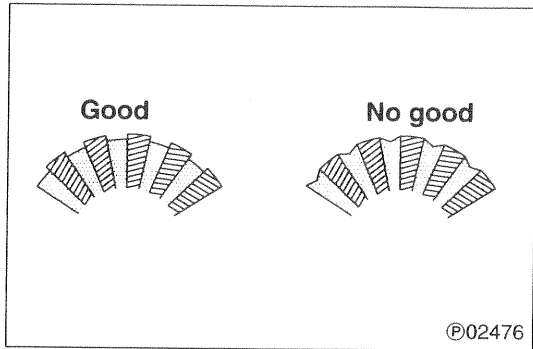

- If the mold portion is as shown, repair or replace the armature assembly 18.

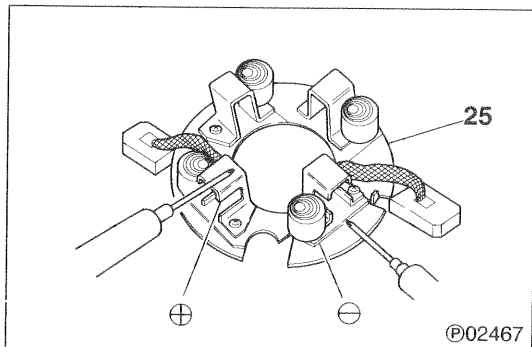

## 25 Inspection of brush holder assembly

- After thoroughly cleaning the brush holder assembly, check to ensure that there is no continuity between the ⊕ side brush holder and ⊖ side holder plate.
- If there is continuity, it means a short circuit. Replace the brush holder assembly 25.

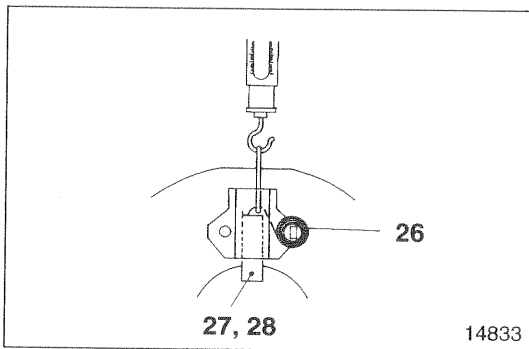

## 26 Inspection of brush spring

- Use new brushes 27 and 28 and measure the load at the moment the brush spring 26 leaves the brushes as shown.
- If the reading is below the limit, replace the brush spring 26.

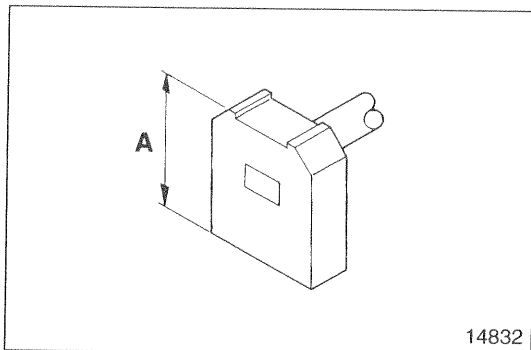

## 27 28 Inspection of brush

### (1) Length of brush

If the reading is less than the limit, replace the brushes 27 and 28.

A: Brush length

### CAUTION

To replace the brush ⊖ 27, replace the brush holder assembly 25.

### (2) Commutator contacting surfaces

If the contacting surfaces are rough or unevenly worn, repair with emery paper (#300 to 500).

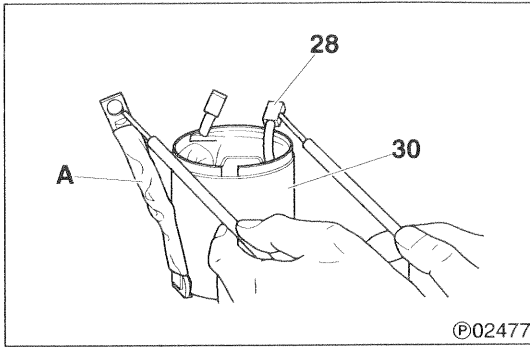

### 30 Inspection of yoke assembly

#### (1) Open circuit test on coil

- Check to ensure that there is continuity between connector **A** and brush  $\oplus$  **28**.
- If there is no continuity, it means an open circuit. Replace the yoke assembly **30**.

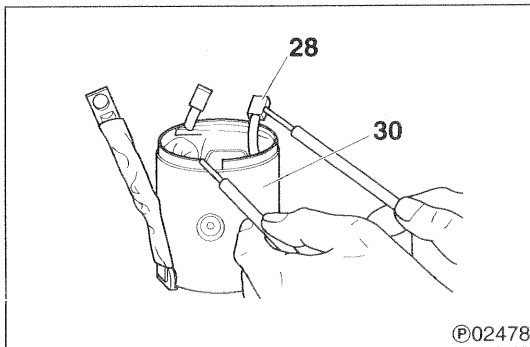

#### (2) Earth test on coil

- Check to ensure that there is no continuity between the yoke assembly **30** and brush  $\oplus$  **28**.
- If there is continuity, it means a short circuit. Check the insulation. If repair is impossible, replace the brush  $\oplus$  **28** or yoke assembly **30**.

#### **CAUTION**

The coil may be short-circuited to the yoke assembly **30** due to the accumulation of worn-off metal particles from the brushes and/or armature.

# STARTER <12V-5kW>

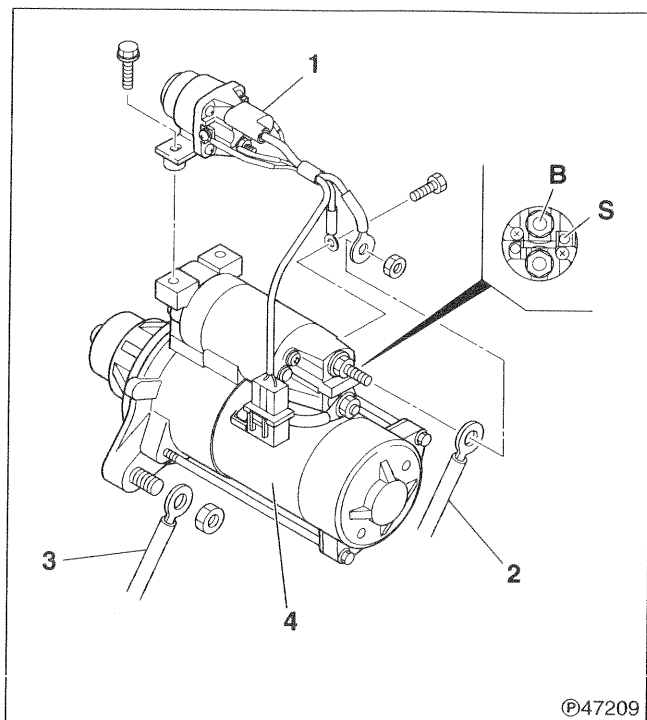

## ● Removal sequence

- 1 Starter relay P.54-149
- 2 Battery cable  $\oplus$
- 3 Earth strap
- 4 Starter assembly P.54-134

B: Terminal B

S: Terminal S

## WARNING

Before removing the starter assembly 4, be sure to disconnect the negative  $\ominus$  terminal of the battery and insulate it with a tape or something else. If the negative  $\ominus$  terminal is not disconnected, the battery voltage is always available at each of terminals B and is dangerous.

## ● Installation sequence

Reverse the order of removal.

---

**M E M O**

---

# STARTER <12V-5kW>

## Starter Assembly

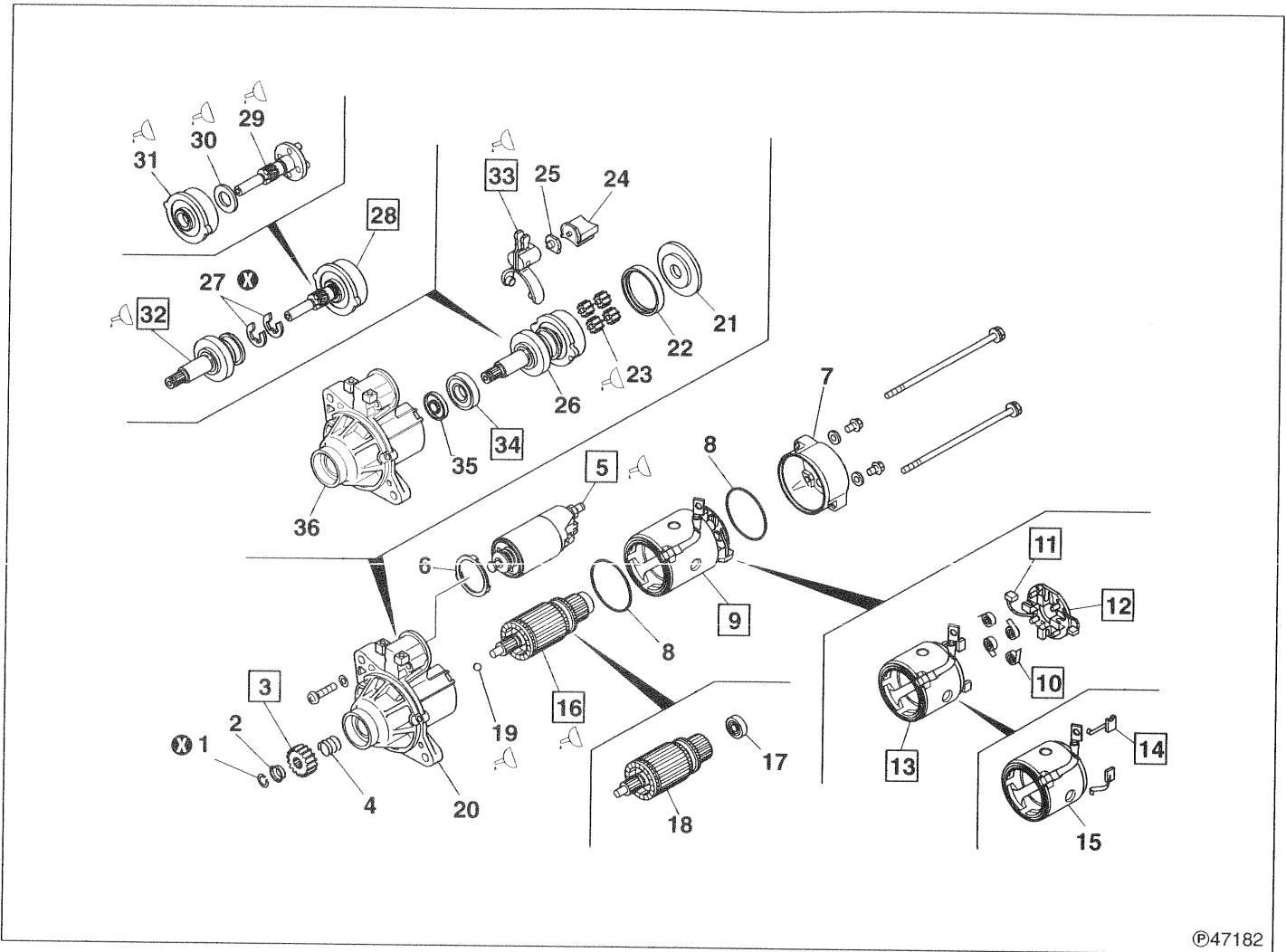

©47182

### ● Disassembly sequence

- |                                |  |                                       |
|--------------------------------|--|---------------------------------------|
| 1 Stopper ring                 | 15 Yoke                                    | 27 E-ring                             |
| 2 Pinion stopper               | 16 Armature assembly                       | 28 Gearshaft & Internal gear assembly |
| 3 Pinion                       | 17 Rear bearing                            | 29 Gear shaft assembly                |
| 4 Spring                       | 18 Armature                                | 30 Washer                             |
| 5 Magnet switch                | 19 Ball                                    | 31 Internal gear                      |
| 6 Shim                         | 20 Front bracket assembly                  | 32 Overrunning clutch                 |
| 7 Rear bracket                 | 21 Cover                                   | 33 Lever assembly                     |
| 8 Packing                      | 22 Packing                                 | 34 Front bearing                      |
| 9 Yoke & brush holder assembly | 23 Planetary gear                          | 35 Oil seal                           |
| 10 Brush spring                | 24 Packing                                 | 36 Front bracket                      |
| 11 Brush ⊖                     | 25 Plate                                   |                                       |
| 12 Brush holder assembly       | 26 Gearshaft & overrunning clutch assembly |                                       |
| 13 Yoke assembly               |  |                                       |
| 14 Brush ⊕                     |  |                                       |

⊗: Non-reusable parts

**CAUTION** 

- Do not remove the bearings 17 and 34 unless defects are evident.
- When the armature assembly 16 is removed, the ball 19 might come out with it. Take care not to lose the ball.
- It is not necessary to remove the pinion 3 when only the motor should be removed and inspected for inspection of the brushes and the related parts.
- Be sure to remove the pinion 3 before disassembling any other parts.

● **Assembly sequence**

Follow the disassembly sequence in reverse.

**CAUTION** 

Whenever the magnetic switch 5 is replaced, the pinion gap must be adjusted.

● **Inspection after reassembly**

 P.54-136

**Service standards**

Unit: mm

Location	Maintenance item			Standard value	Limit	Remedy
—	Pinion gap			0.5 to 2.0	—	Adjust
—	No-load characteristics	During 11V supply	Current	230A or less	—	Check
			Rotating speed	3400 rpm or more	—	
10	Spring pressure of brush spring			29 to 39 N {3 to 4 kgf}	20 N {2 kgf}	Replace
11, 14	Brush length			18	11	Replace
16	Outside diameter of commutator			32	31.4	Replace
	Commutator outer circumferential runout			—	0.05 or more	
	Depth of mica between segments			0.5	0.2 or less	Repair or replace

 **Lubricant**

Location	Points of application	Specified lubricant	Quantity
5	Lever contact surface of magnetic switch	Multipurpose grease [NLGI No.2 (Li soap)]	As required
16	Teeth of armature assembly gear	MOLYKOTE® AG650	As required
16, 29	Sliding surfaces of armature assembly and gear shaft assembly	MOLYKOTE® AG650	As required
19	Ball	MOLYKOTE® AG650	As required
23, 31	Teeth of planetary gear and internal gear	MOLYKOTE® AG650	As required
29, 32	Sliding surfaces of gear shaft assembly and overrunning clutch	Multipurpose grease [NLGI No.2 (Li soap)]	As required
30	Washer	MOLYKOTE® AG650	As required
32	Splines of overrunning clutch	Multipurpose grease [NLGI No.2 (Li soap)]	As required
33	Sliding surfaces of lever assembly and overrunning clutch	Multipurpose grease [NLGI No.2 (Li soap)]	As required

# STARTER <12V-5kW>

## ◆ Service procedure

### ● Inspection after reassembly

After reassembly, check the starter by supplying current.

### WARNING ⚠

- When current is supplied to the starter, the pinion 3 will spring out and rotate. Be careful not to touch it by hand.
- The magnet switch 5 may be very hot after the end of inspection. Be careful when you touch it.

### CAUTION ⚠

- The time during which current is supplied to the starter should be limited to 10 seconds or less on the pull-in coil P side and 30 seconds or less on the holding coil H side. If current is supplied to the coils for a longer period, the coils will be overheated and baked.
- When current is supplied to the starter, a large current that exceeds 100A will flow. When the starter is inspected, therefore, use thick cables like booster cables. Check to ensure that all the connections are tight and secure.

### (1) Performance test

- Wire the starter as shown.

A: Ammeter

B: Starter terminal B

C: Switch

D: DC power supply

S: Starter terminal S

V: Voltmeter

- Set the voltage at 11V DC.

### CAUTION ⚠

The voltage that is applied should be limited to 12V maximum.

- The following operations are performed by supplying current to the starter. It is therefore necessary that the series of operations ranging from measuring the current that flows through the starter to measuring the rotating speed are completed in less than 30 seconds.

- Set the switch C to ON to supply current to the starter. At the time, the pinion 3 will spring out and rotate.

### CAUTION ⚠

When the switch C is set to ON, current is supplied to both the pull-in coil P and holding coil H. When the large current from the DC power supply D is supplied from terminal B of the starter to terminal M, the current to the pull-in coil is interrupted, and current flows to the holding coil only.

To prevent baking the holding coil, therefore, all the operations must be completed in less than 30 seconds.

- Measure the current and rotating speed of the starter. Measure the rotating speed of the starter by illuminating the pinion 3 with a stroboscope.
- Set the switch C to OFF to stop supplying current to the starter.
- If the reading is out of the standard value, disassemble and check the starter.

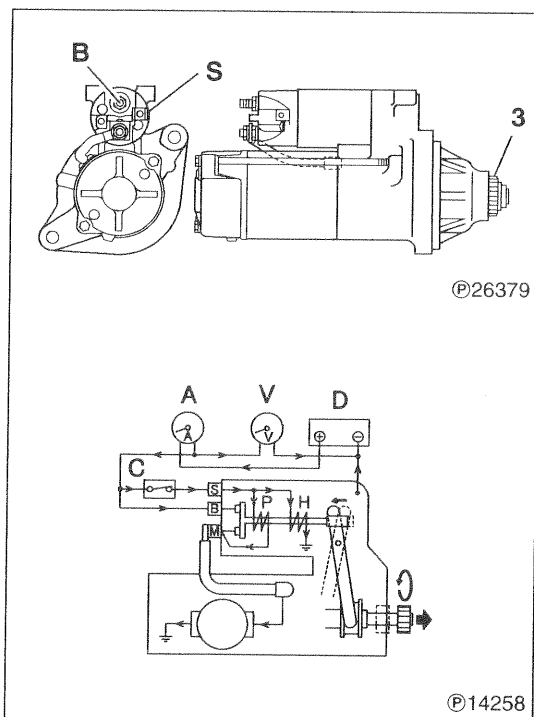
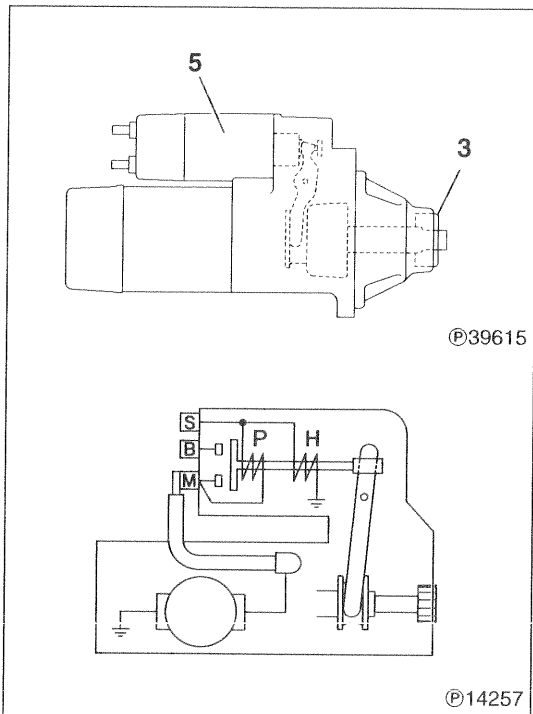

**(2) Pinion gap**

[Inspection]

- Wire the starter as shown.

**C:** Switch**E:** Switch**F:** Cable**M:** Starter terminal M**S:** Starter terminal S

- The following operations are performed by supplying current to the starter. It is therefore necessary that the series of operations up to completion of measurement of the pinion gap is completed in less than 30 seconds.

- Set the switch **C** and switch **E** to ON to supply current to the starter. At the time, the pinion **3** will spring out and rotate.

- Immediately (in less than 5 seconds) after the pinion has started rotation, set the switch **E** to OFF to stop rotation of the pinion.

**CAUTION** 

When the switch **C** and switch **E** are set to ON, current is supplied to both the pull-in coil **P** and holding coil **H**. Since wiring is such that no voltage is applied to terminal **B** of the starter, current flows to the pull-in coil during rotation of the pinion **3**. To prevent baking the pull-in coil, therefore, it is necessary that the switch **E** is set to OFF immediately (in less than 5 seconds) after the pinion has started rotating.

- Pull out the overrunning clutch **32** by hand, then push back its end lightly and measure the amount **G** the clutch moves in the axial direction (pinion gap).
- Set the switch **C** to OFF to stop supplying current to the starter.
- If the reading is out of the standard value, replace the lever assembly **33**.

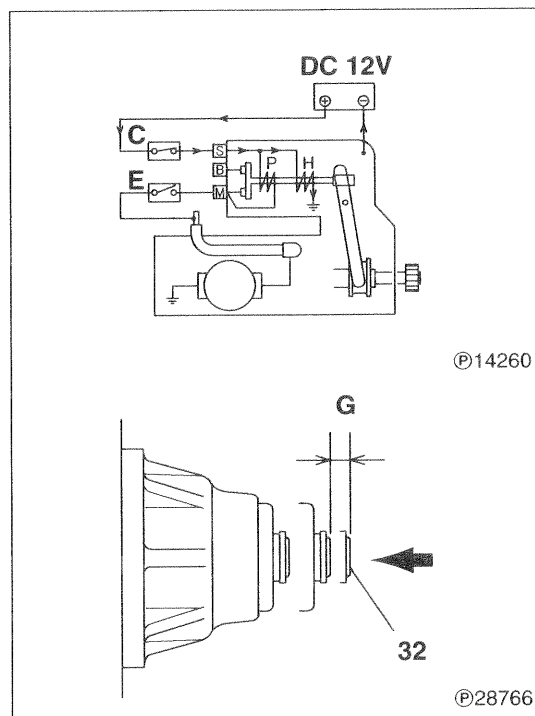
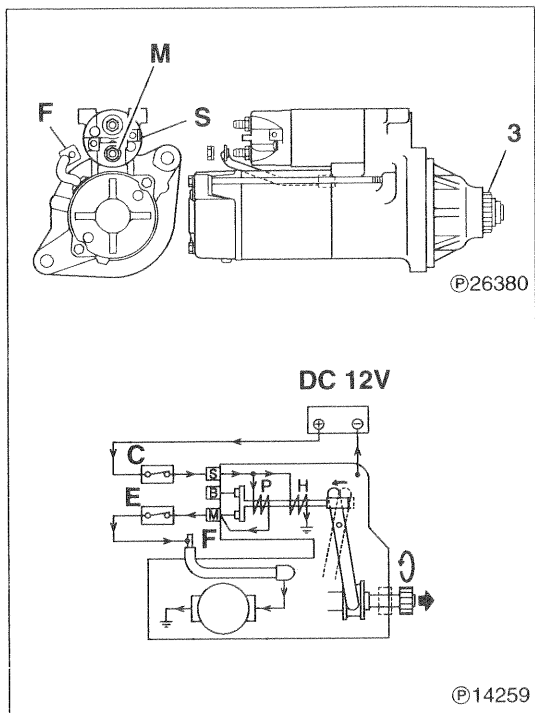

# STARTER <12V-5kW>

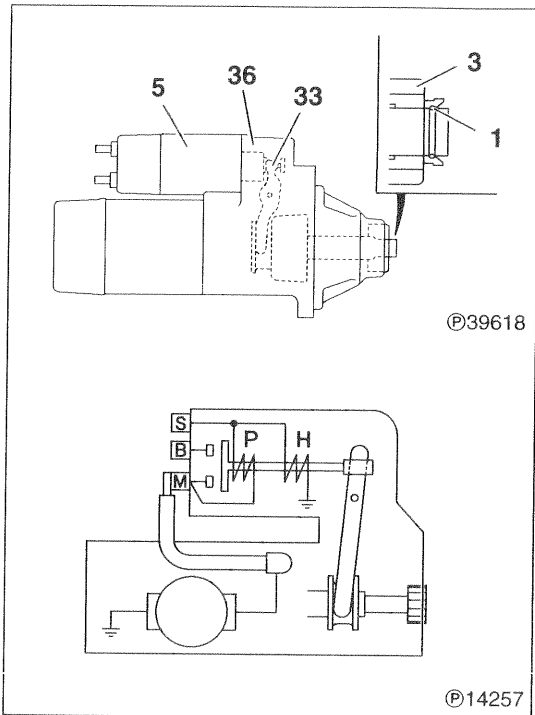

## 3 Pinion

[Removal]

To remove the pinion 3, it is necessary to supply current to the starter and let the pinion spring out.

### WARNING

- When current is supplied to the starter, the pinion 3 will spring out and rotate. Be careful not to touch it by hand.
- The magnet switch 5 may be very hot after the end of inspection. Be careful when you touch it.

### CAUTION

- The time during which current is supplied to the starter should be limited to 10 seconds or less on the pull-in coil P side and 30 seconds or less on the holding coil H side. If current is supplied to the coils for a longer period, the coils will be overheated and baked.
- Make sure that the pinion 3 is made to spring out by supplying current to the starter. If the pinion is forced out by pulling the lever assembly 33 without supplying current to the starter, the front bracket 36 and lever could be damaged by the impact produced when the stopper ring 1 is removed.
- When current is supplied to the starter, a large current that exceeds 100A will flow. When the starter is inspected, therefore, use thick cables like booster cables. Check to ensure that all the connections are tight and secure.

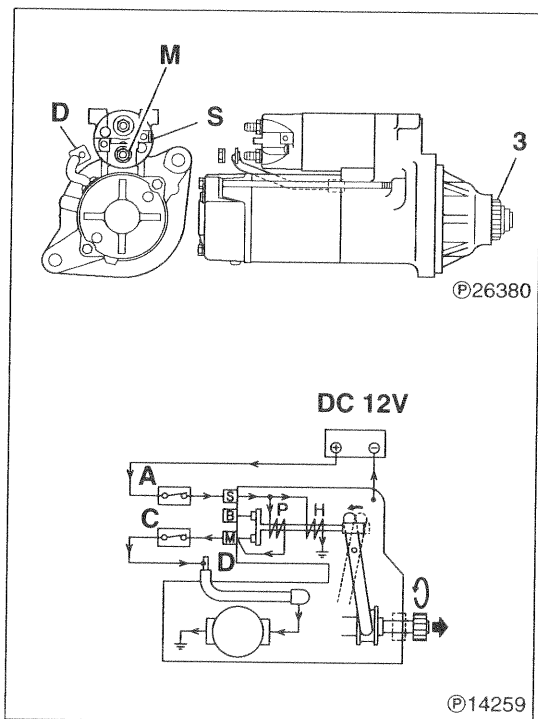

- Wire the starter as shown.

A: Switch  
 C: Switch  
 D: Cable  
 M: Starter terminal M  
 S: Starter terminal S

- The following operations are performed by supplying current to the starter. It is therefore necessary that the series of operations up to removal of the pinion 3 is completed in less than 30 seconds.
  - Set the switch A and switch C to ON to supply current to the starter. At the time, the pinion 3 will spring out and rotate.

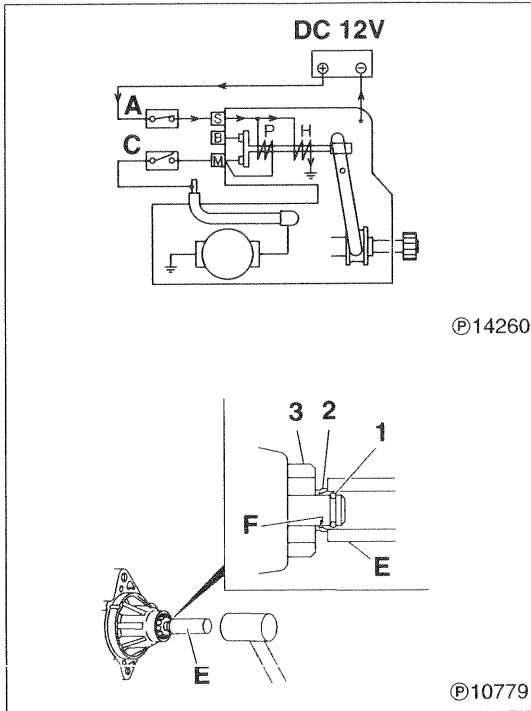

- Immediately (in less than 5 seconds) after the pinion 3 has started rotating, set the switch C to OFF to stop rotation of the pinion.

### CAUTION ⚠

When the switch A and switch C are set to ON, current is supplied to both the pull-in coil P and holding coil H. Since wiring is such that no voltage is applied to terminal B of the starter, current flows to the pull-in coil during rotation of the pinion 3.

To prevent baking the pull-in coil, therefore, it is necessary that the switch C is set to OFF immediately (in less than 5 seconds) after the pinion has started rotating.

- Set the pipe-like tool E on the pinion stopper 2.
- Lightly strike the tool E with a hammer to remove the stopper ring 1 from the ring groove F of the pinion stopper 2.
- Remove the stopper ring 1 and remove the pinion 3.
- Set the switch A to OFF to stop supplying current to the starter.

### CAUTION ⚠

When the power supply to the starter is stopped, the pinion 3 may move in and the stopper ring 1 may fit in the ring groove F of the pinion stopper 2 again.

In this case, repeat the operations by supplying current to the starter.

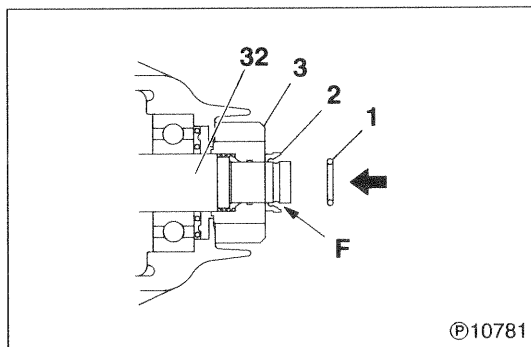

### [Installation]

To install the pinion 3, it is not necessary to supply current to the starter.

- Install the pinion stopper 2 and pinion 3 on the overrunning clutch 32 in the direction shown.
- Set the stopper ring 1 in the ring groove F of the overrunning clutch 32.

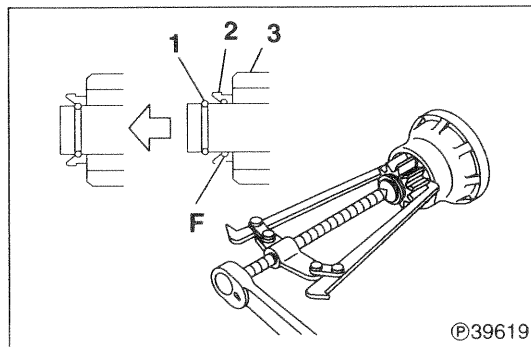

- Pull the pinion 3 strongly to make sure that the stopper ring 1 securely fits in the ring groove F of the pinion stopper 2.

# STARTER <12V-5kW>

## 5 Magnet switch

[Installation]

Install the magnet switch 5 on the lever assembly 33 with terminal S in the direction shown.

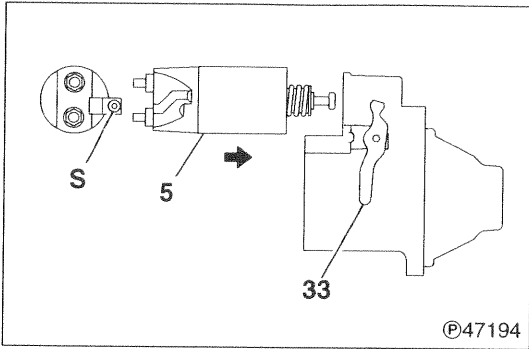

[Inspection]

### (1) Open circuit test on coil

- Check to ensure that there is continuity between terminals S and M.
- If there is no continuity, replace the magnet switch 5.

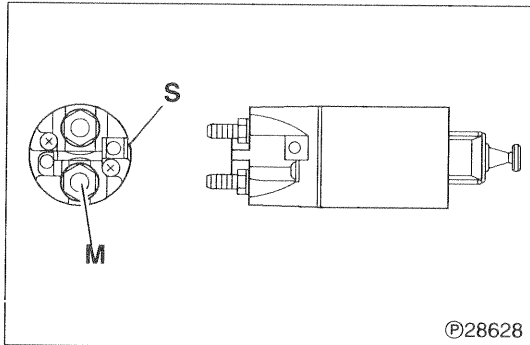

- Check to ensure that there is continuity between terminal M and body A.
- If there is no continuity, replace the magnet switch 5.

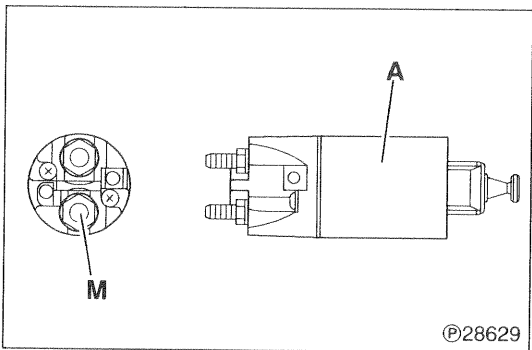

### (2) Contact fusion check

- Check to ensure that there is no continuity between terminals B and M.
- If there is continuity, replace the magnet switch 5.

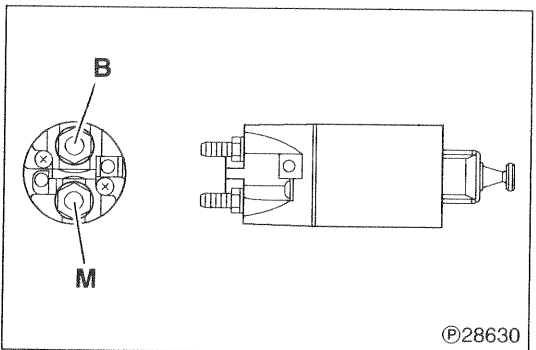

### (3) Contact contacting check

- Push the end of the magnet switch 5 in to close the internal contact. In this state, check to ensure that there is continuity between terminals B and M.
- If there is no continuity, replace the magnet switch 5.

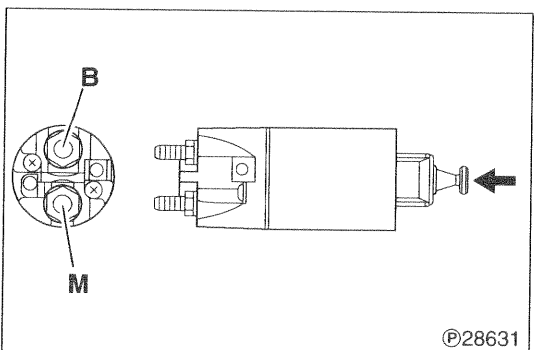

### 9 Removal of yoke & brush holder assembly

To remove the yoke & brush holder assembly **9**, proceed as described below, while using care to prevent damage to the commutator **A** of the armature assembly **16** by the brushes **11** and **14**.

- Keep the brushes **11** and **14** apart from the commutator **A** and hold the brush spring **10** alongside the brushes.

- Remove the yoke & brush holder assembly **9** from the front bracket assembly **20**.

**CAUTION**  **When the yoke & brush holder assembly **9** is removed, do not tilt it downward. Otherwise, the armature assembly **16** may fall down.**

- For installation, reverse the order of removal.

### 10 Inspection of brush spring

- Use new brushes **11** and **14** and measure the load at the moment the brush spring **10** leaves the brushes as shown.
- If the reading is less than the limit, replace the brush spring **10**.

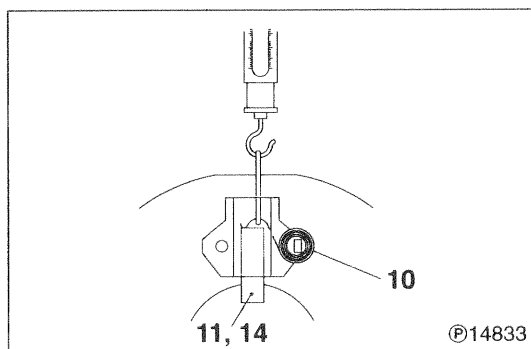
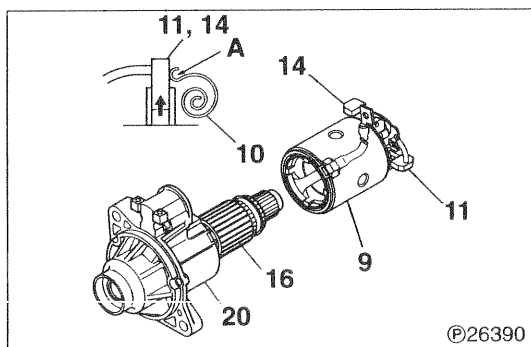
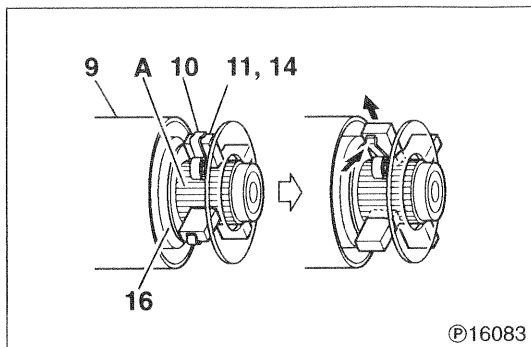

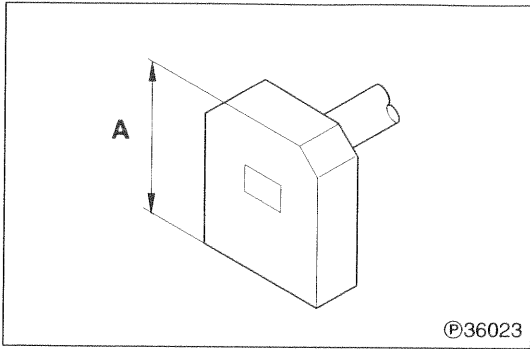

## 11 14 Inspection of brush

### (1) Length of brush

If the reading is less than the limit, replace the brushes 11 and 14.

A: Brush length

### CAUTION

To replace the brush  $\ominus$  11, replace the brush holder assembly 12.

### (2) Commutator contacting surfaces

If the contacting surfaces are rough or unevenly worn, repair with emery paper (#300 to 500).

## 12 Inspection of brush holder assembly

- Check to ensure that there is no continuity between the  $\oplus$  side brush holder and  $\ominus$  side holder plate.
- If there is continuity, it means a short circuit. Replace the brush holder assembly 12.

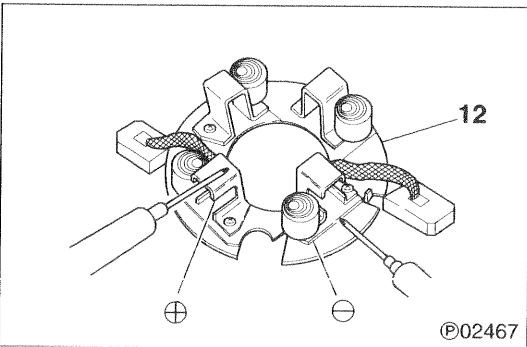

## 13 Inspection of yoke assembly

### (1) Open circuit test on coil

- Check to ensure that there is continuity between cable A and brush  $\oplus$  14.
- If there is no continuity, it means an open circuit. Replace the brush  $\oplus$  14 or yoke assembly 13.

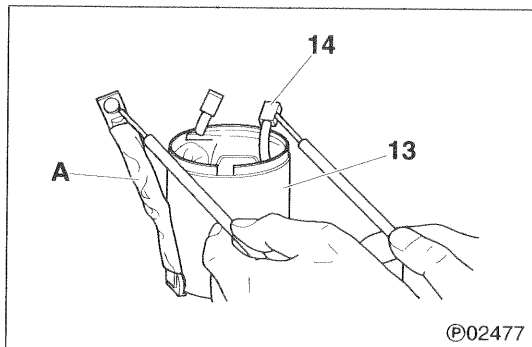

### (2) Earth test on coil

- Check to ensure that there is no continuity between the yoke assembly 13 and brush  $\oplus$  14.
- If there is continuity, it means a short circuit. Check the insulation. If repair is impossible, replace the brush  $\oplus$  14 or yoke assembly 13.

### CAUTION

The coil may be short-circuited to the yoke assembly 13 due to the accumulation of worn-off metal particles from the brushes and/or armature.

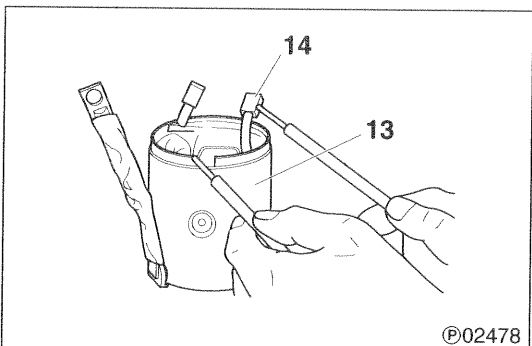

## 16 Inspection of armature assembly

### (1) Short circuit test on coil

- Bring the iron piece A close to the armature assembly 16, keeping it in parallel.

B: Armature tester

- Slowly rotate the armature assembly 16 by hand.
- If the iron piece A is attracted or vibrates, it means a short circuit. Replace the armature assembly 16.

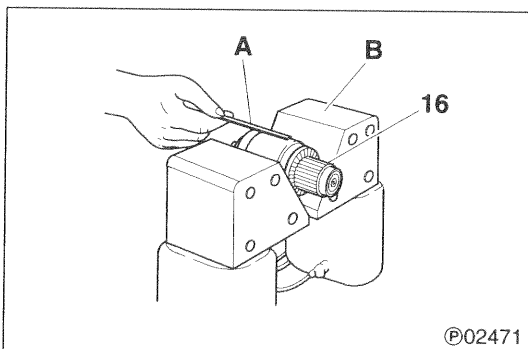

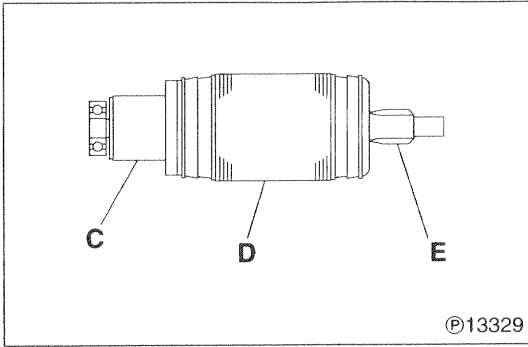

## (2) Earth test on coil

- Check to ensure that there is no continuity between the commutator **C** and core **D** (or shaft portion **E**).
- If there is continuity, it means a short circuit. Replace the armature assembly **16**.

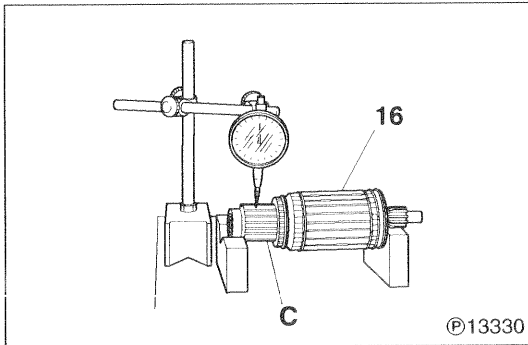

## (3) Runout of commutator

If the reading is more than the limit, repair the outside diameter of the commutator portion **C** of the armature assembly **16** within the limit.

## (4) Condition of commutator surface

- If the surface is rough or unevenly worn, repair with emery paper (#300 to 500).
- After the repair, be sure to check the runout of the commutator portion **C**.

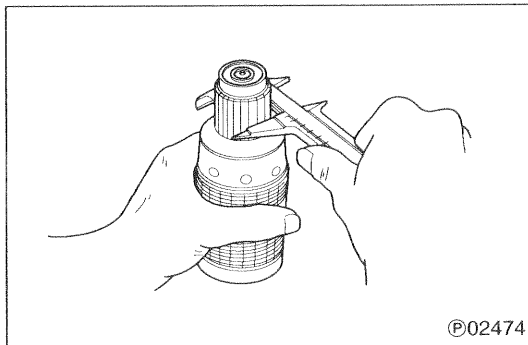

## (5) Outside diameter of commutator

If the reading is more than the limit, replace the armature assembly **16**.

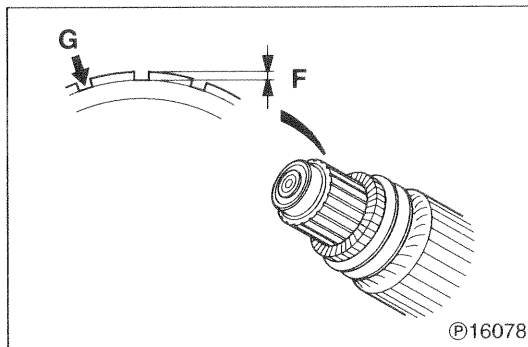

## (6) Depth of mold between segments

Before inspection, clean the mold portions.

- If the reading is less than the limit, repair or replace the armature assembly **16**.

**F**: Depth of mold

- Make repairs by grinding the illustrated portion **G**.

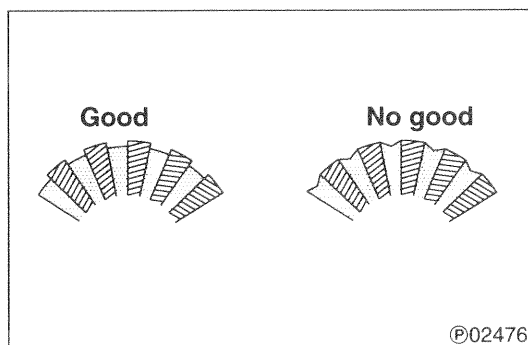

## 28 Removal of gear shaft and internal gear assembly

Remove the E-rings 27 and then the gear shaft and internal gear assembly 28 from the overrunning clutch 32.

Proceed as follows if the assembly 28 cannot be removed due to interference of the splined section A of gear shaft assembly 29 with internal parts of the overrunning clutch 32.

- Press the gear shaft assembly 29 against the overrunning clutch 32.
- Turn the gear shaft assembly 29 approx. 1/8 of a turn to change the position of splined section A.

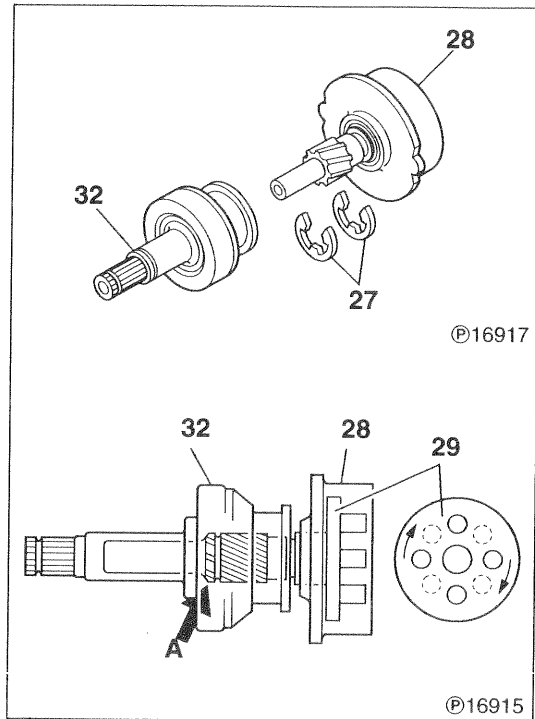

## 32 Inspection of overrunning clutch

Perform the following checks. If there is anything wrong, replace the overrunning clutch 32.

- Check to ensure that when the shaft A is made to rotate in the direction B, it rotates smoothly.
- Check to ensure that when the shaft A is made to rotate in the direction C, it is locked.

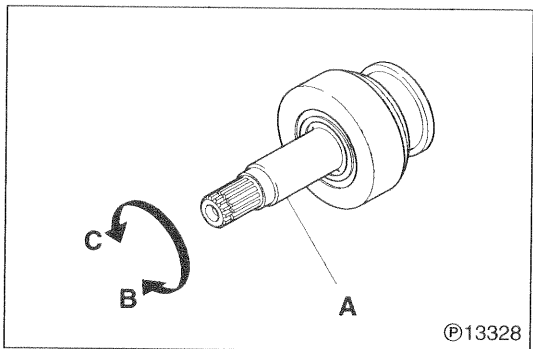

## 33 Installation of lever assembly

Install the lever assembly 33 in the illustrated direction on the overrunning clutch 32.

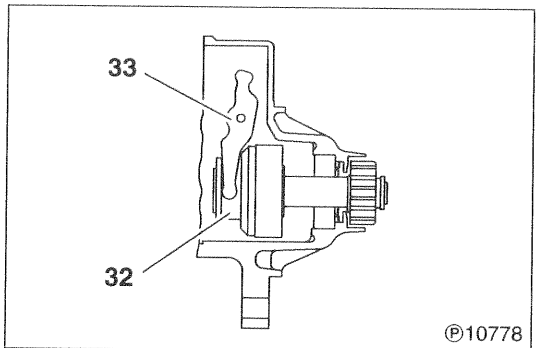

**34** Installation of front bearing

- Before the front bearing **34** is press-fitted, install the oil seal **35**.
- Press-fit the front bearing **34** in the front bracket **36** with a press, using the pipe-like tool **A**.

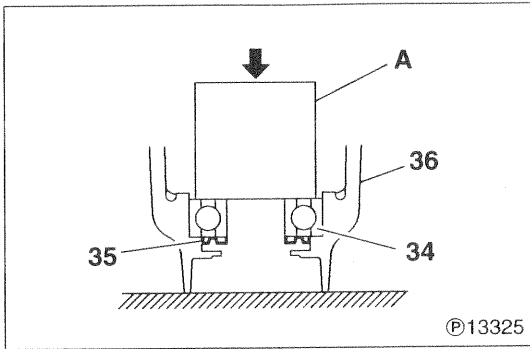

- Stake the front bracket **36** side.

**CAUTION**  **Avoid staking the previously staked points B.**

**C**: Staking points (4 places)

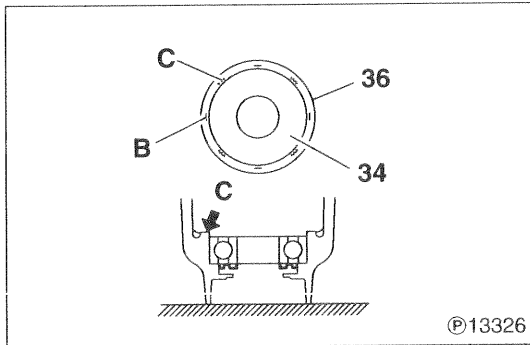

# PREHEATER CIRCUIT

## <24V (air heater) specification>

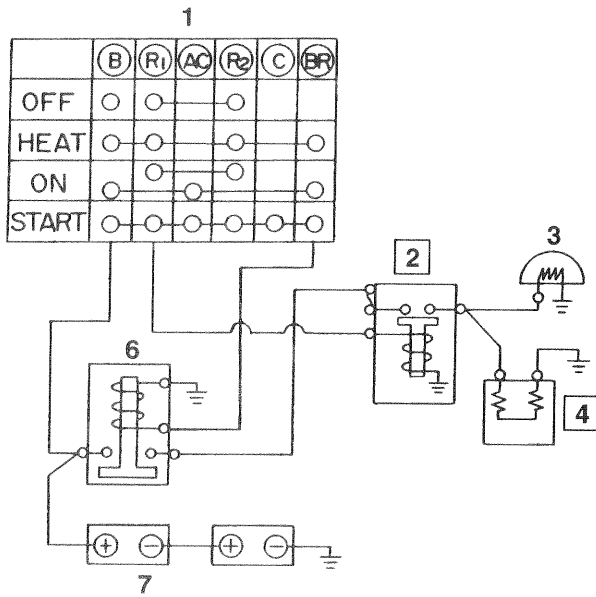

- 1 Starter switch
- 2 Heater relay (or glow relay)
- 3 Heater indicator (vehicles with air heater)  
Glow plug indicator  
(vehicles with glow plugs)
- 4 Intake air heater
- 5 Glow plug
- 6 Battery relay (24V specification)  
Battery switch (12V specification)
- 7 Battery

18461

## <24V (glow plug) specification>

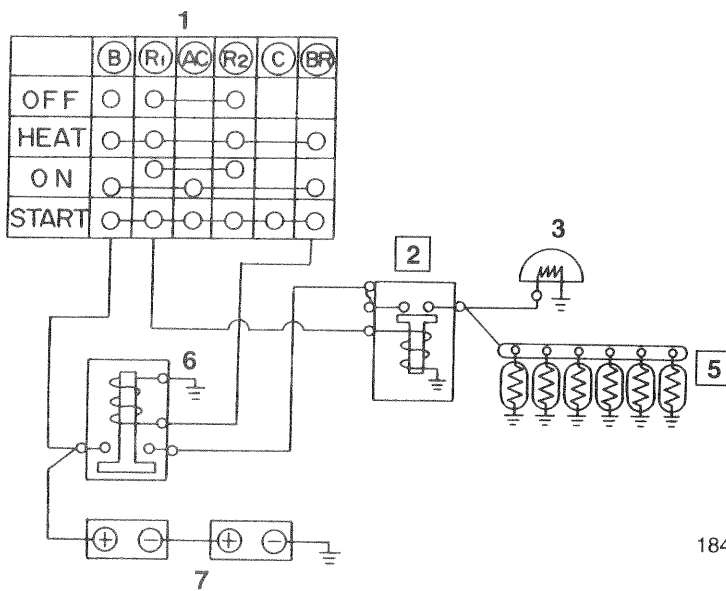

18462

## <12V specification>

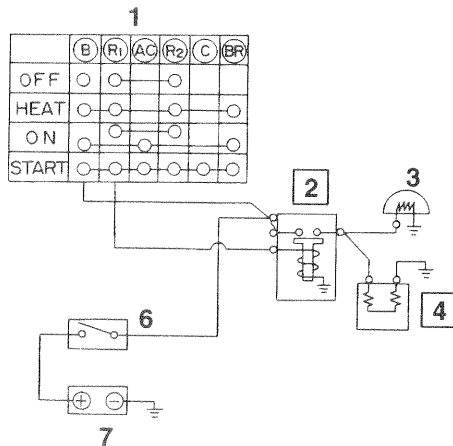

18463

**Service standards**

Location	Maintenance item	Standard value	Limit	Remedy
5	Resistance of glow plug at normal temperature	3.8 Ω	—	Replace

◆ **Service procedure**

**2** Inspection of heater relay (or glow relay)

**(1) Inspection of heater**

If the fuse **A** is blown, replace it with one having the same amperage stamped on the fuse.

**(2) Inspection of main body**

- Perform continuity checks according to the following table.

	①	②	③	④	⑤ (Body earth)
When no current is supplied	○—○			○—○	
When current is supplied	○—○	○—○	○—○	⊕—⊖	

- There is continuity between terminals.
- ⊕—⊖ Terminals to which battery voltage is applied:  
DC24V <24V system>  
DC12V <12V system>

**A**: Fuse

- If there is anything wrong, replace the heater relay (or glow relay) **2**.

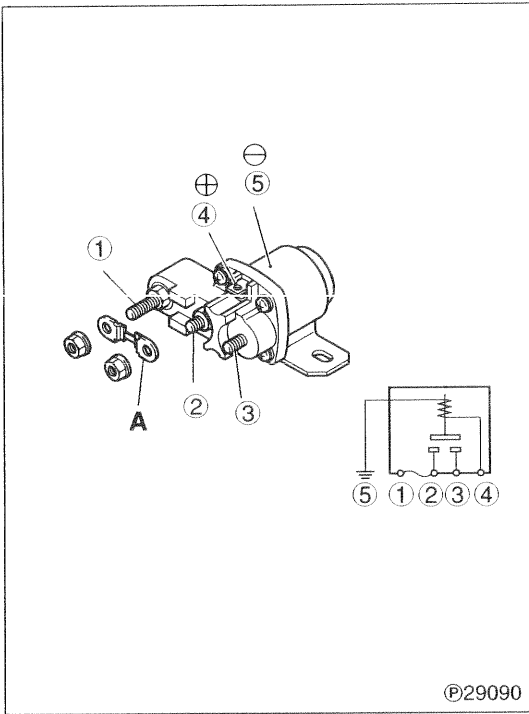

©29090

# PREHEATER CIRCUIT

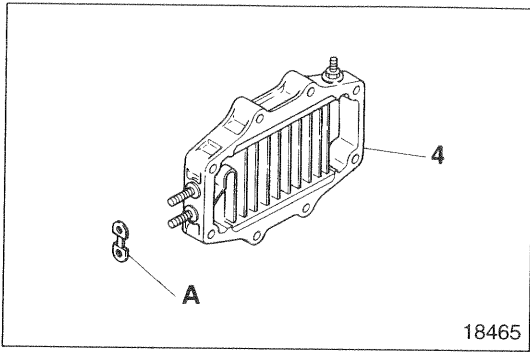

## 4 Inspection of intake air heater

### (1) Inspection of fuse

If there is anything wrong, replace the fuse **A** (127A).

**A**: Fuse (127A)

### (2) Inspection of main body

Check the terminals for looseness, and the heater element for damage and loose contact with the glass.

- If there is anything wrong, replace the intake air heater **4**.

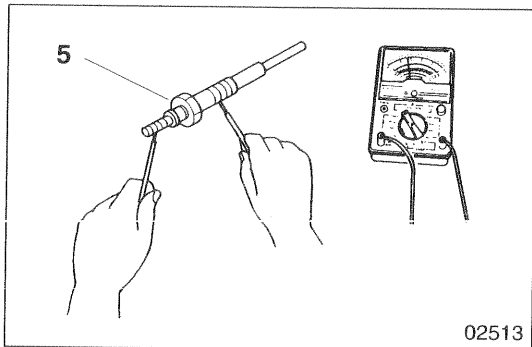

## 5 Inspection of glow plug

- Measure the resistance of the glow plug **5** as shown.
- If the reading is out of the standard value, replace the glow plug **7**.

 Gr 11

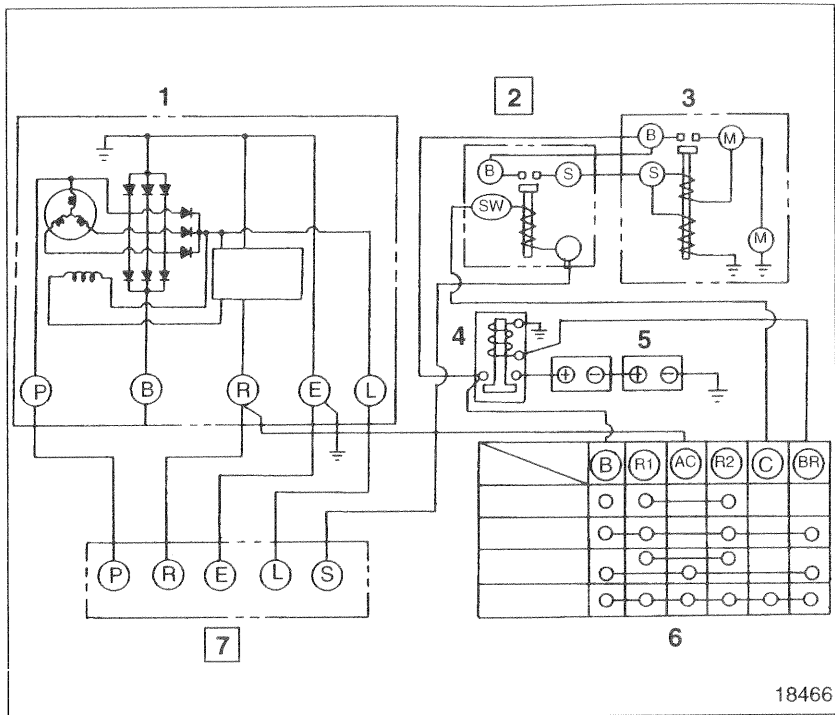

- 1 Alternator
- 2 Starter relay
- 3 Starter
- 4 Battery relay (24V)
- 5 Battery
- 6 Starter switch
- 7 Safety relay

18466

### Service standards

Location	Maintenance item	Standard value	Limit	Remedy
7	Safety relay	Approx. 200Ω	—	Replace

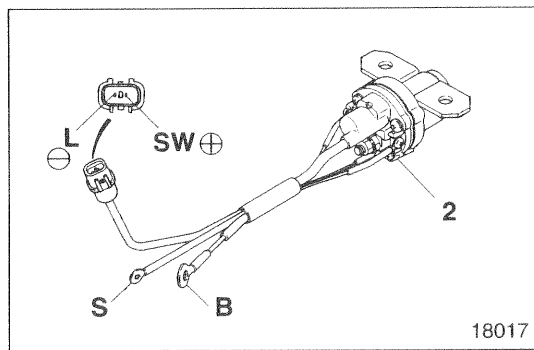

18017

### ◆ Service procedure

#### 2 Inspection of starter relay

- Perform continuity checks according to the following table.

	B	S	SW	L
When no current is supplied			○ — ○	○ — ○
When current is supplied	○ — ○	○ — ○	⊕ — ⊖	⊕ — ⊖

- — ○ There is continuity between terminals.
- ⊕ — ⊖ Terminals to which battery voltage is applied  
DC24V <24V system>  
DC12V <12V system>

- If there is anything wrong, replace the starter relay 2.

#### 7 Inspection of safety relay

Measure the resistance value between terminals R-L. If the reading is out of the standard value, replace the safety relay 7.

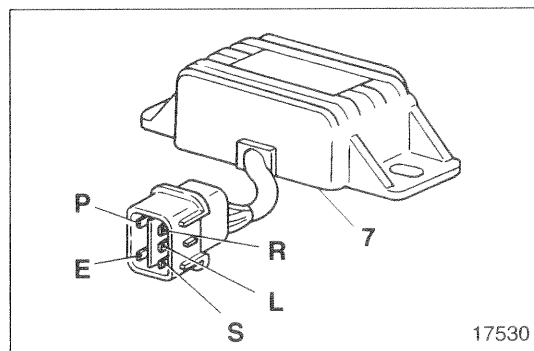

17530

# AUTOMATIC STOP SYSTEM (SHUTDOWN)

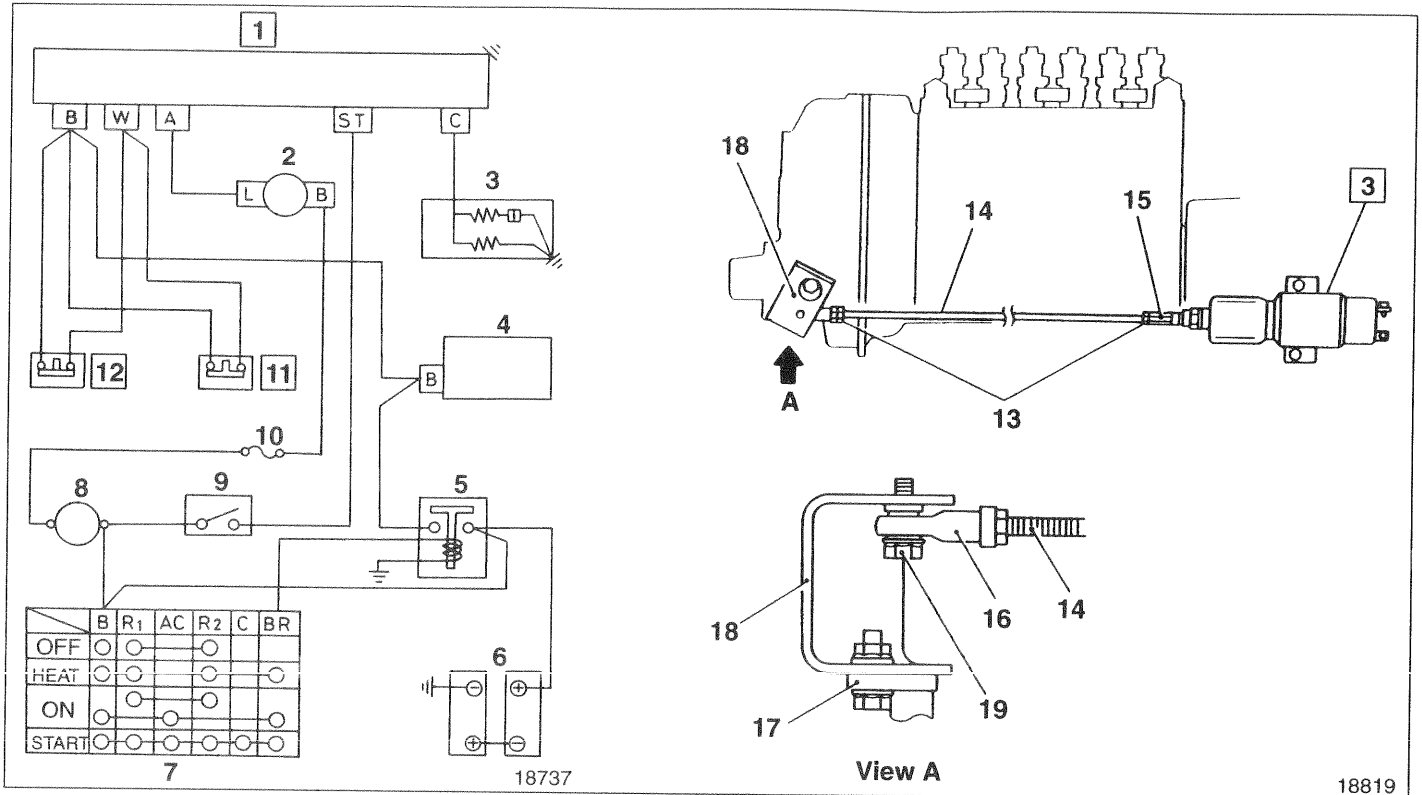

- |                  |                               |                 |
|------------------|-------------------------------|-----------------|
| 1 Solenoid relay | 8 Ammeter                     | 14 Rod          |
| 2 Alternator     | 9 Stop switch                 | 15 Swivel joint |
| 3 Solenoid       | 10 Fuse box                   | 16 Ball joint   |
| 4 Starter        | 11 Engine oil pressure switch | 17 Base lever   |
| 5 Battery relay  | 12 Coolant temperature sensor | 18 Stop lever   |
| 6 Battery        | 13 Lock nut                   | 19 Flange bolt  |
| 7 Starter switch |                               |                 |

## Service standards

Unit: mm

Location	Maintenance item		Standard value	Limit	Remedy
1	Solenoid relay	Delay time at start (after application of 28.5V to terminal B, and 28.5V to terminal A)	18 ± 5 secs.	—	Replace
		Delay time at stop (after application of 24V to terminal B and 0V to terminal A)	30 ± 5 secs.	—	Replace
3	Solenoid	Clearance between base lever and case stopper	1.2 ± 0.2	—	Adjust
		Holding coil current	0.5A or less	—	Replace
11	Engine oil pressure switch operating pressure		78 ± 20 kPa {0.8 ± 0.2 kgf/cm <sup>2</sup> }	—	Replace
12	Coolant temperature sensor operating temperature	City water cooling	95 ± 2°C	—	Replace
		Radiator cooling	101 ± 2°C	—	Replace

## ◆ Service procedure

### 1 Solenoid relay

Wire as shown at left and perform the following inspections.

- F: Power supply
- G: Switch
- H: Solenoid (or coil load:  $30 \pm 3A$ )
- J: Switch
- K: Switch
- L: Power supply

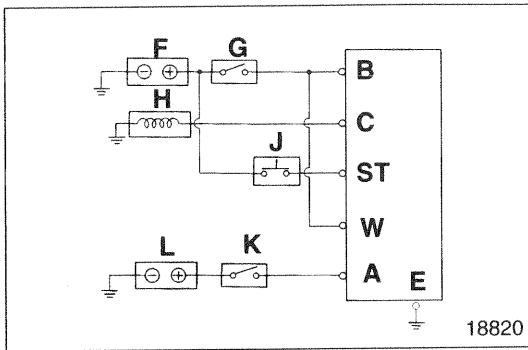

#### (1) Inspection of oil pressure timer

- Connect 28.5V DC power supplies to **F** and **L**.
- Set the switch **G** to ON.
- Set the switch **K** to ON and simultaneously measure the time required before the solenoid **H** operates.
- If the reading is out of the standard value, replace defective parts.

#### NOTE

When the timer is to be re-tested, allow a recovery time of five minutes as the discharge finishing time of the capacitor in the solenoid relay 1.

#### (2) Inspection of stop timer

- Connect 24V DC power supply to **F** and 28.5V DC power supply to **L**.
- Set the switches **G** and **K** to ON.
- Set the switch **K** to OFF 5 seconds after the solenoid **H** has operated. (It takes 5 seconds for the generating voltage of alternator **2** to disappear after the activation of the solenoid.) At the same time, measure the time required before the solenoid returns.
- If the reading is out of the standard value, replace defective parts.

#### NOTE

When the timer is to be re-tested, allow a recovery time of five minutes as the discharge finishing time of the capacitor in the solenoid relay.

#### (3) Manual stop timer

- Connect 24 V DC power supply to **F**.
- Set the switch **J** to ON to operate the solenoid **H**.
- Measure the time required for the solenoid **H** to return after setting the switch **J** to OFF.
- If the reading is out of the standard value, replace defective parts.

# AUTOMATIC STOP SYSTEM (SHUTDOWN)

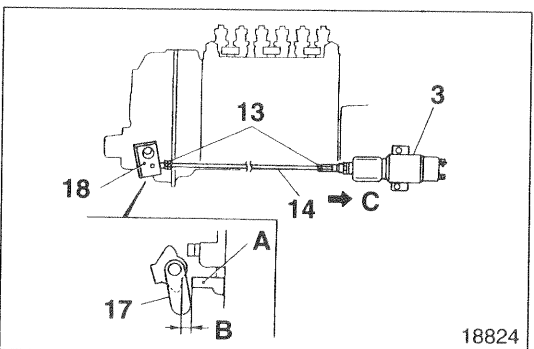
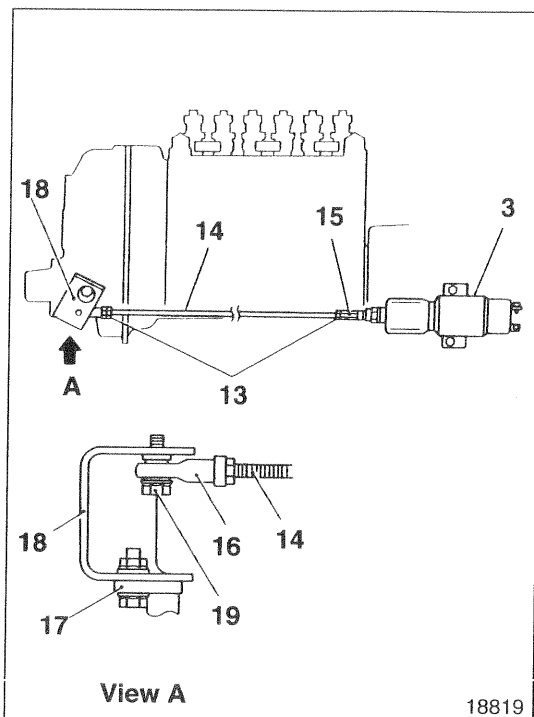

## 3 Solenoid

### [Installation]

- Temporarily tighten the ball joint 16 to the rod 14 and thread the other end six to nine times into the swivel joint 15 and secure it with lock nuts 13.
- Check to ensure that the rotating portions of the swivel joint 15 and ball joint 16 smoothly rotate.
- Mount the solenoid 3 on the engine.
- Rotate the ball joint 16 to adjust the length of rod 14, place the stop lever 18 in the normal use position, and install the ball joint with the flange bolt 19.

### [Adjustment]

- Adjust the length of the rod 14 so that the clearance B between the base lever 17 and case stopper A will have the standard value with the solenoid 3 in operation.

C: Solenoid moving direction

- Firmly tighten the lock nuts 13 at both ends of the rod 14 and stop operation of the solenoid.

**CAUTION** ⚠ \_\_\_\_\_  
**Do not continue to supply current to the solenoid 3 for more than 20 seconds. Otherwise the solenoid may be burned.**

- Switch the switch of the circuit between ON and OFF repeatedly two or three times and check the following items.

**CAUTION** ⚠ \_\_\_\_\_  
**Do not switch the switch rapidly between ON and OFF.**

- Check to ensure that the stop lever 18, rod 14 and solenoid 3 move smoothly.
- Check to ensure that the clearance B between the base lever 17 and case stopper A have the standard value.

[Inspection]

Wire as shown at left and perform the following checks.

### NOTE

The checks can be performed by use of either the ammeter **C** or lamp **D**.

**A** : Power supply

**B** : Switch

**C** : Ammeter

- Set the switch **B** to ON.
- If the reading of the ammeter **C** after activation of solenoid **3** is out of the standard value or the lamp **D** does not light, replace the solenoid.

### CAUTION

When the check lamp does not light, do not continue to supply current to the solenoid **3** for more than 20 seconds. Otherwise the solenoid may be burned.

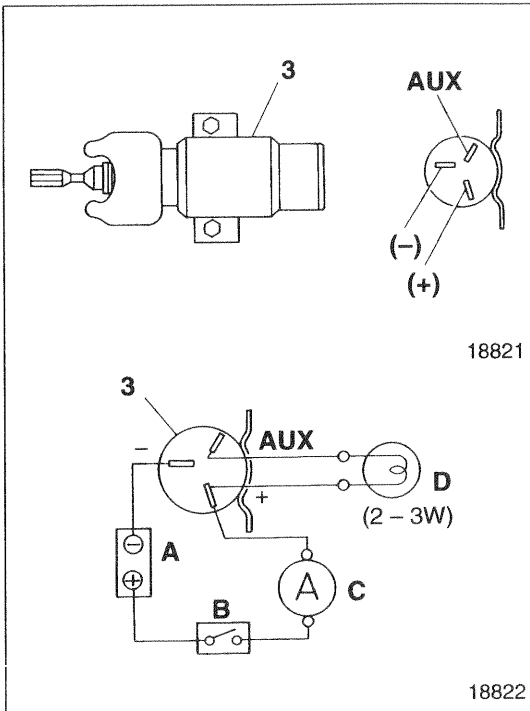

### 11 Inspection of engine oil pressure switch

Perform the following checks. If defective, replace the engine oil pressure switch **11**.

- Under the condition where no air pressure **A** is applied to the engine oil pressure switch **11**, check to ensure that there is continuity between the terminals ① and ②.
- Slowly apply the air pressure **A** to the engine oil pressure switch **11**, beginning at 0 kPa (0 kgf/cm<sup>2</sup>).

When there is no more continuity between the terminals ① and ②, measure the air pressure and check to ensure that the air pressure has the standard value.

**B** : Air pressure gauge

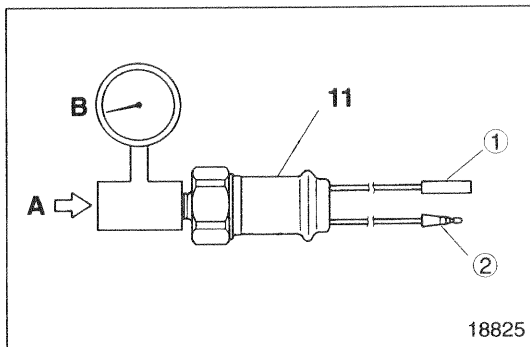

### 12 Inspection of coolant temperature sensor

- Put the coolant temperature sensor **12** in a container filled with engine oil.
- Before raising the oil temperature, check to ensure that there is no continuity between the terminals ① and ②.
- Slowly raise the oil temperature and stir the engine oil well.
- Measure the temperature at the time when there is continuity between the terminals ① and ②.
- If the reading is out of the standard value, replace defective parts.

### NOTE

When the oil temperature is near the operating temperature, slowly heat the oil. (When the operating temperature  $-5^{\circ}\text{C}$  is reached, leave it alone for five minutes, and then raise the oil temperature at a rate of  $1^{\circ}\text{C}$  in two or three minutes.)

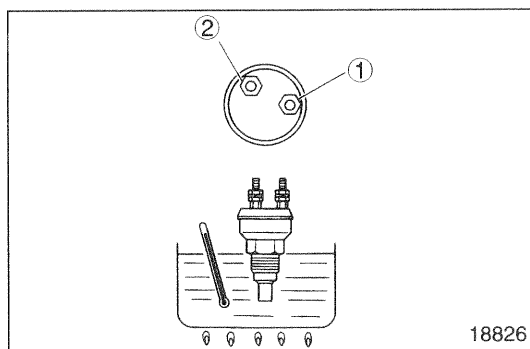

# AUTOMATIC STOP SYSTEM <RUN-ON>

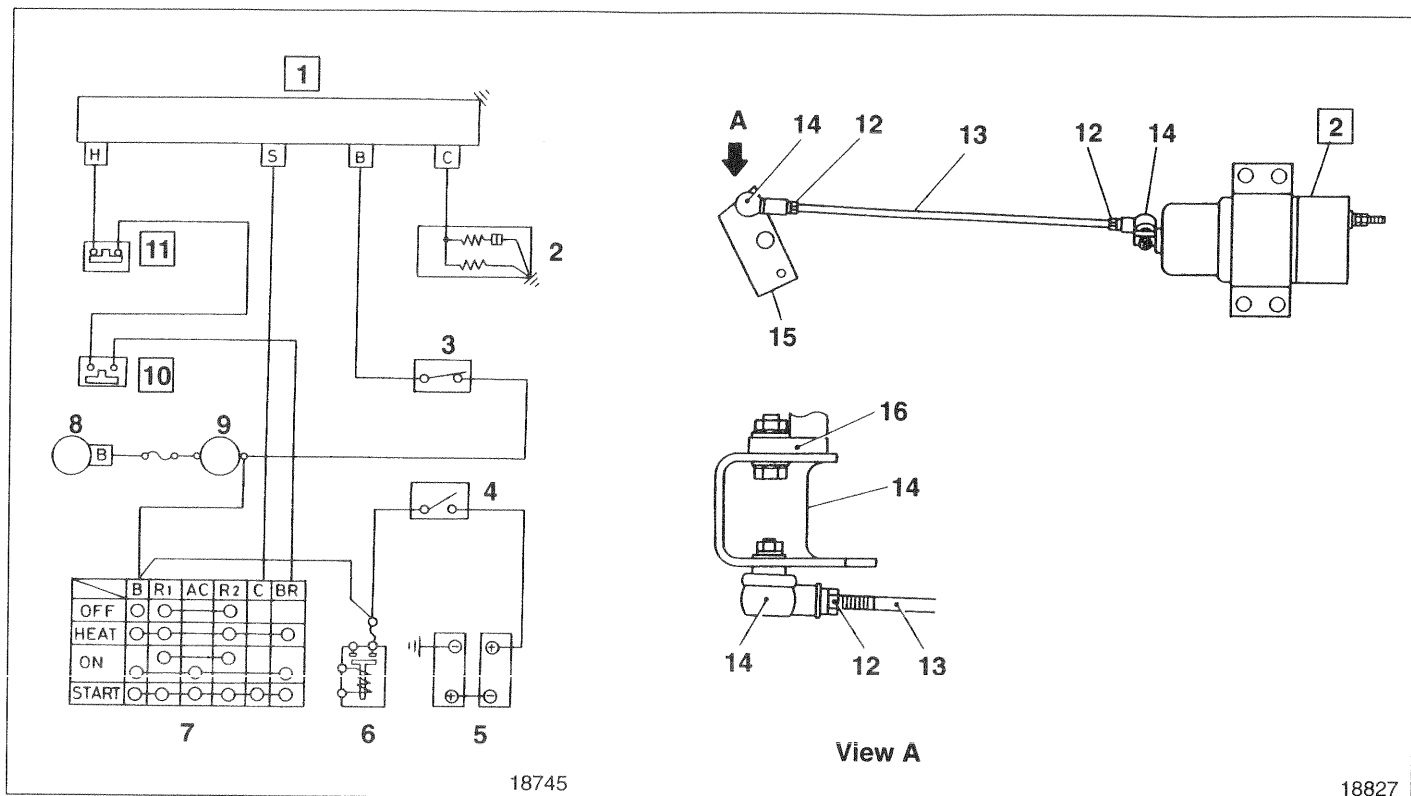

18745

18827

- |                  |                               |               |
|------------------|-------------------------------|---------------|
| 1 Solenoid relay | 7 Starter switch              | 12 Lock nut   |
| 2 Solenoid       | 8 Alternator                  | 13 Rod        |
| 3 Stop switch    | 9 Ammeter                     | 14 Ball joint |
| 4 Battery switch | 10 Engine oil pressure switch | 15 Stop lever |
| 5 Battery        | 11 Coolant temperature sensor | 16 Base lever |
| 6 Heater relay   |                               |               |

## Service Standards

Unit: mm

Location	Maintenance item	Standard value	Limit	Remedy	
1	Solenoid relay delay time	30 ± 4 secs.	—	Replace	
2	Solenoid	Pointer clearance	0.8 to 1.5	—	Replace
		Clearance between stop lever and external stopper	0.4 to 0.5	—	Replace
	Holding coil current	24V system	1A or less	—	Replace
12V system		5A or less	—	Replace	
11	Engine oil pressure switch operating pressure	78 ± 20 kPa {0.8 ± 0.2 kgf/cm <sup>2</sup> }	—	Replace	
12	Coolant temperature sensor operating temperature	City water cooling	95 ± 2°C	—	Replace
		Radiator cooling	101 ± 2°C	—	Replace

## ◆ Service procedure

### 1 Solenoid relay

Wire as shown at left and perform the following checks.

- F: Power supply  
 G: Switch  
 J: Solenoid (or coil load:  $30 \pm 3A$ )  
 K: Switch  
 L: Switch

#### (1) Inspection of operation of solenoid relay 1 and delay time

- Check to ensure that when the switches **G** and **L** are set to ON, the solenoid **J** operates.
- Set the switch **L** to OFF and simultaneously measure the time required before the solenoid **J** is deactivated.

#### (2) Inspection of relay holding time

- Set the switches **G** and **L** to ON. After the solenoid **J** has operated, set the switch **K** to ON.
- Set the switch **L** to OFF and check to ensure that the solenoid **J** stays in the operating state for more than 30 seconds.
- After checking that the solenoid **J** is in the operating state, set the switch **K** to OFF to check that the solenoid is deactivated.

### 2 Solenoid

[Installation]

- Install the ball joint **14** to the rod **13** and temporary tighten with lock nut **12**.
- Check to ensure that the ball joint **14** moves smoothly.
- Install the solenoid **2** to the engine.
- With the stop lever **15** in the stop position, install the rod **13**. Adjust the rod length by turning it.

[Adjustment]

- Remove the cover of the solenoid **2**.
- Apply the specified voltage to solenoid **2** and energize the solenoid.
- Check that the clearance **A** between the pointers of the solenoid is within the standard value.

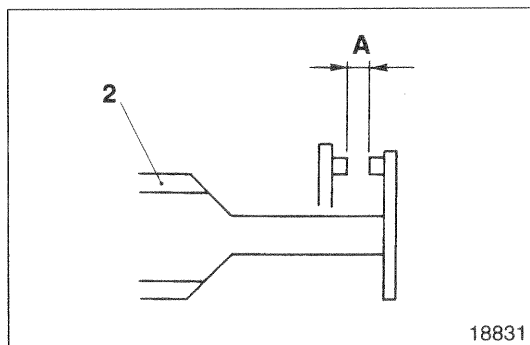
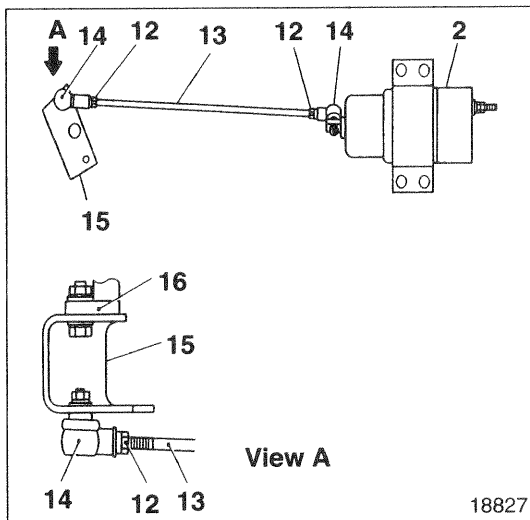
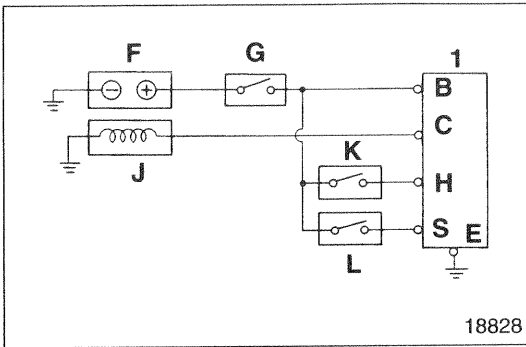

# AUTOMATIC STOP SYSTEM <RUN-ON>

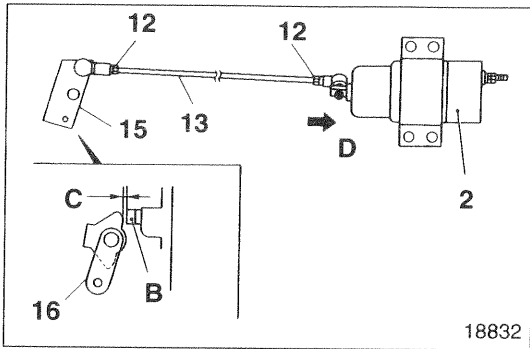

- With the solenoid 2 kept energized, adjust the clearance **C** between the base lever 16 and the case stopper **B** to the standard value by turning the rod 13.

**D**: Solenoid moving direction

- Deenergize the solenoid 2.
- Firmly tighten the lock nut 12.
- Switch the solenoid 2 between ON and OFF repeatedly two or three times (with approx. 10 seconds of internal) and check the following items.

## CAUTION

**Do not switch the solenoid rapidly between ON and OFF.**

- Check to ensure that the stop lever 15, rod 13 and solenoid 2 operate smoothly.
- Check to ensure that the clearances **A** and **C** fall within the standard limits.
- Mount the cover of solenoid 2.

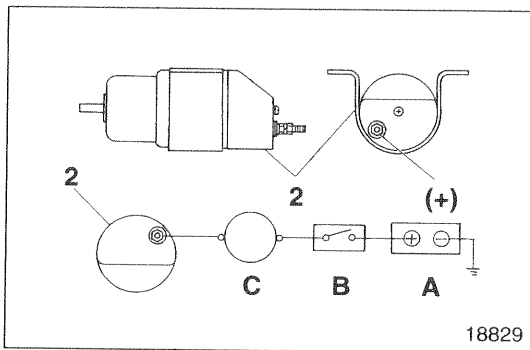

[Inspection]

Wire as shown at left and perform the following checks.

**A**: Power supply  
**B**: Switch  
**C**: Ammeter

- Set the switch **B** to ON.
- If the reading of the ammeter **C** after the activation of solenoid 1 is out of the standard value, replace the solenoid.

## 10 Inspection of engine oil pressure switch

Perform the following checks. If defective, replace the engine oil pressure switch 10.

- Under the condition where no air pressure **A** is applied to the engine oil pressure switch 10, check to ensure that there is no continuity between the terminals ① and ②.
- Slowly apply the air pressure **A** to the engine oil pressure switch 10, beginning at 0 kPa (0 kgf/cm<sup>2</sup>).

When there is continuity between the terminals ① and ②, measure the air pressure and check to ensure that the air pressure has the standard value.

**B**: Air pressure gauge

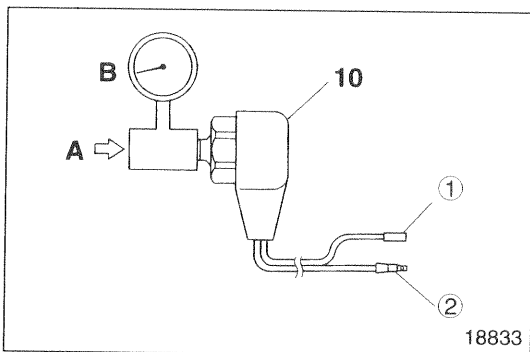

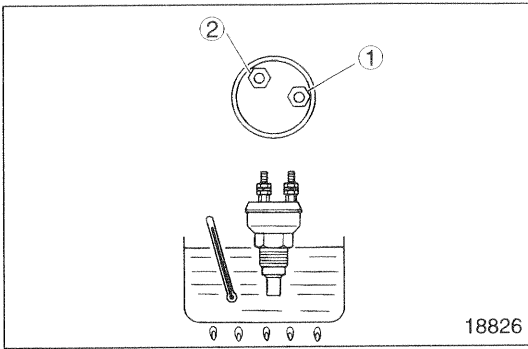

### 11 Inspection of coolant temperature sensor

- Put the coolant temperature sensor in a container filled with engine oil.
- Before raising the oil temperature, check to ensure that there is continuity between the terminals ① and ②.
- Slowly raise the oil temperature and stir the engine oil well.
- Measure the temperature at the time when there is no more continuity between the terminals ① and ②.
- If the reading is out of the standard value, replace defective parts.

#### NOTE

When the oil temperature is near the operating temperature, slowly heat the oil. (When the operating temperature  $-5^{\circ}\text{C}$  is reached, leave it alone for five minutes, and then raise the oil temperature at a rate of  $1^{\circ}\text{C}$  in two or three minutes.)





---

---

**6D1**  
diesel engine  
**Shop Manual**  
(for industrial use)

 **MITSUBISHI MOTORS CORPORATION**

SEPTEMBER 2001



**GENERAC<sup>®</sup>**  
**POWER SYSTEMS, INC.**

*P.O. BOX 310 EAGLE, WI 53119*

**Part No. OE7084**

**Revision 0 (08/01/03)**

**Printed in U.S.A.**