

GENERAC[®]

POWER SYSTEMS, INC.

GR-125
Operation and
Maintenance Manual

Standby Output 110 kW (137 kVA)
Prime Output 100 kW (125 kVA)

Liquid-cooled
Diesel Engine
Generator Set

Model No. 004063-0 (Trailerized)
004363-0 (w/o Trailer)

INTRODUCTION

This Owner's Manual was prepared especially for the purpose of familiarizing personnel with the operation and servicing of the applicable equipment.

Every effort was expended to make sure that the information and instructions in the Manual are accurate and current at the time the Manual was written. However, the manufacturer reserves the right to change, alter or otherwise improve product(s) at any time without prior notice.



CAUTION: Read all instructions and safety rules before attempting to operate or service this (and related) equipment. Protect yourself and others by strictly complying with these instructions and rules. Failure to comply with these safety rules may result in personal injury, death or damage to equipment and/or property. Retain these instructions for future reference.

■ READ THIS MANUAL THOROUGHLY

If you do not understand any portion of this manual, contact Generac or your nearest Generac Authorized Service Dealer for starting, operating and servicing procedures.

Throughout this publication, and on tags and decals affixed to the generator, DANGER, WARNING, CAUTION and NOTE blocks are used to alert you to special instructions about a particular operation that may be hazardous if performed incorrectly or carelessly. Observe them carefully.

These safety warnings cannot eliminate the hazards that they indicate. Common sense and strict compliance with the special instructions while performing the service are essential to preventing accidents.

The following definitions apply to DANGER, WARNING, CAUTION and NOTE blocks found throughout the manual.



DANGER: After this heading, you can read handling, installing, operating or servicing instructions that, if not strictly complied with, will result in personal injury.



WARNING: After this heading, you can read handling, installing, operating or servicing instructions that, if not strictly complied with, may result in personal injury.



CAUTION: After this heading, you can read instructions for handling, installing, operating or servicing the generator that, if not strictly complied with, could result in damage to equipment and/or property.

NOTE: After this heading, you can read explanatory statements that require special emphasis.

These symbols indicate the following:



Points out important safety information that, if not followed, could endanger personal safety and/or property of you and others.



Points out potential explosion hazard.



Points out potential fire hazard.



Points out potential electrical shock hazard.

The operator is responsible for proper and safe use of the equipment. We strongly recommend that the operator read this *Owner's Manual* and thoroughly understand all instructions before using this equipment. We also strongly recommend instructing other users to properly start and operate the unit. This prepares them if they need to operate the equipment in an emergency.

■ OPERATION AND MAINTENANCE

It is the operator's responsibility to perform all safety checks, to make sure that all maintenance for safe operation is performed promptly, and to have the equipment checked by an authorized dealer periodically. Normal maintenance service and replacement of parts are the responsibility of the owner/operator and, as such, are not considered defects in materials or workmanship within the terms of the warranty. Individual operating habits and usage contribute to the need for maintenance service.

Proper maintenance and care of your generator ensures a minimum number of problems and keeps operating expenses at a minimum. See your Generac authorized dealer/distributor for service aids and accessories.

■ HOW TO OBTAIN SERVICE

When the generator set requires servicing or repairs, simply contact an authorized service facility for assistance. Service technicians are factory-trained and are capable of handling all service needs.

When contacting an authorized service facility or the factory about parts and service, always supply the complete model number, serial number, and vin number of the unit as given on its data decal.

The warranty on the generator is included in this *Owner's Manual*, as well as listings for repair parts.

<p>INTRODUCTIONInside Front Cover</p> <p> Read This Manual Thoroughly Inside Front Cover</p> <p> Operation and Maintenance Inside Front Cover</p> <p> How to Obtain Service Inside Front Cover</p> <p>SERVICE DEALER LOCATION1</p> <p>SAFETY RULES2</p> <p>IDENTIFICATION RECORD4</p> <p> Data Plate4</p> <p>EQUIPMENT DESCRIPTION4</p> <p> Standard Generator Features4</p> <p> Generator Specifications.....4</p> <p> Engine Specifications4</p> <p>INSTALLATION5</p> <p> Standby Electric System.....5</p> <p>EMERGENCY CIRCUIT ISOLATION6</p> <p>TOTAL CIRCUIT ISOLATION6</p> <p>PREPARATION BEFORE USE7</p> <p> Engine Lubrication7</p> <p> Engine Coolant7</p> <p> Fuel7</p> <p> Cord Sets - 120 Volts GFCI Duplex Receptacle7</p> <p> 120 Volt Amp Locking Type Receptacle8</p> <p> 120/208 to 139/240 Volts, 50 Amp Locking Type Receptacle.....8</p> <p> Full Capacity Terminal Compression Lugs8</p> <p> Transfer Switch Terminal9</p> <p> Starting Battery10</p> <p>SWITCHES, METERS AND LIGHTS10</p> <p> AC Voltmeter10</p> <p> AC Ammeter10</p> <p> Frequency Meter11</p> <p> Oil Pressure Gauge11</p> <p> Coolant Temperature Gauge.....11</p> <p> DC Ammeter11</p> <p> Hourmeter11</p> <p> System Ready Lamp11</p> <p> Pre-Heat Switch11</p> <p> Fault Indicator Lamp11</p> <p> Start/Run/Off Switch11</p> <p> Auto/Off/Manual Switch11</p> <p> Panel Light12</p> <p> Voltage Adjust Dial12</p> <p> Phase Selection Switch12</p> <p>ENGINE PROTECTIVE DEVICES.....12</p> <p> Low Oil Pressure Switch.....12</p> <p> High Coolant Temperature Switch12</p>	<p> Low Coolant Level Sensor12</p> <p> DC Control/Latch-Crank Circuit Board13</p> <p> Engine Startup13</p> <p> After Fault Shutdown13</p> <p> Overspeed.....13</p> <p> Overcrank Shutdown.....13</p> <p>OPERATING INSTRUCTIONS13</p> <p> Before Starting13</p> <p> Starting the Engine13</p> <p> Shut Down13</p> <p> Operation In Ice Or Snow13</p> <p> Grounding the Generator13</p> <p> Ground Fault Protection14</p> <p>MAINTENANCE14</p> <p> 100-Hour Break In Period14</p> <p> 100-Hour Break In14</p> <p>RECOMMENDED ENGINE FLUIDS15</p> <p> Engine Oil15</p> <p> Engine Coolant15</p> <p> Supplemental Coolant Additives.....15</p> <p> Fuel15</p> <p>CHECKING FLUID LEVELS15</p> <p> Engine Oil15</p> <p> Engine Coolant16</p> <p> Fuel16</p> <p>OWNER/OPERATOR PERIODIC MAINTENANCE.....16</p> <p>BLEEDING THE FUEL SYSTEM.....17</p> <p>PERIODIC MAINTENANCE LIST17</p> <p> Daily17</p> <p> Every 50 Hours or 2 Weeks17</p> <p> Every 250 Hours17</p> <p> Every 600 Hours or 12 Months.....17</p> <p> Every 1200 Hours or 24 Months.....17</p> <p> Every 2000 Hours17</p> <p>ADJUSTMENT OF FUEL INJECTION TIMING.....17</p> <p>ENGINE SPEED ADJUSTMENT.....17</p> <p>VOLTAGE REGULATOR ADJUSTMENT18</p> <p>GENERATOR ROTOR BEARING18</p> <p>MAJOR REPAIRS18</p> <p> How to Order Parts18</p> <p>WIRING DIAGRAMS/SCHEMATICS19-26</p> <p>EXPLODED VIEWS27-44</p> <p>NOTES45-46</p> <p>WARRANTIES47-Back Cover</p>
---	---

SERVICE DEALER LOCATION

TO LOCATE THE NEAREST GENERAC SERVICING DEALER, PLEASE CALL OUR 800 NUMBER.
ONLY DEALER LOCATION INFORMATION CAN BE OBTAINED AT THIS NUMBER.

1-800-333-1322



THE MANUFACTURER SUGGESTS THAT THESE RULES FOR SAFE OPERATION BE COPIED AND POSTED IN POTENTIAL HAZARD AREAS. SAFETY SHOULD BE STRESSED TO ALL OPERATORS AND POTENTIAL OPERATORS OF THIS EQUIPMENT.



WARNING:



The engine exhaust from this product contains chemicals known to the state of California to cause cancer, birth defects or other reproductive harm.



WARNING:



This product contains or emits chemicals known to the state of California to cause cancer, birth defects or other reproductive harm.

Study these "SAFETY RULES" carefully before installing, operating or servicing this equipment. Become familiar with the Owner's Manual and with the unit. The generator can operate safely, efficiently and reliably only if it is properly set up, operated and maintained. Many accidents are caused by failing to follow simple and fundamental rules or precautions.

Generac cannot possibly anticipate every possible circumstance that might involve a hazard. The warnings in this manual, and on tags and decals affixed to the unit, are, therefore, not all-inclusive. If you use a procedure, work method or operating technique Generac does not specifically recommend, you must satisfy yourself that it is safe for you and others. You also must make sure the procedure, work method or operating technique that you choose does not render the generator unsafe.



DANGER: Despite the safe design of this generator set, operating this equipment imprudently, neglecting its maintenance or being careless can cause possible injury or death. Permit only responsible and capable persons to operate or maintain this equipment.



DANGER: Generator sets can be dangerous. Only suitably qualified personnel should attempt to install or work on this type of equipment.



DANGER: Potentially lethal voltages are generated by these machines. Ensure all steps are taken to render the machine safe before attempting to work on the generator set.



DANGER: Parts of the generator set are rotating and/or hot during operation. Exercise care near running generator sets.



For safety reasons, Generac recommends that the initial start-up of this equipment is carried out by a Generac Authorized Dealer.

- Adequate, unobstructed flow of cooling and ventilating air is critical to correct generator set operation. Do not alter the installation or permit even

partial blockage of ventilation provisions, as this can seriously affect safe operation of the generator set.

- Diesel engine exhaust fumes contain carbon monoxide, which can be DEADLY. This dangerous gas, if breathed in sufficient concentrations, can cause unconsciousness or even death. This exhaust system must be properly installed, in strict compliance with applicable codes and standards. Following installation, you must do nothing that might render the system unsafe or in noncompliance with such codes and standards. Inspect the exhaust system regularly to ensure that it is free from leaks and damage, and that it is not possible for fumes to enter any area where people or animals are located. Never operate this equipment with a leaking or defective exhaust system. Repair or replace any damaged or leaking component immediately.
- Keep hands, feet, clothing, etc., away from drive belts, fans, and other moving or hot parts. Never remove any drive belt or fan guard while the unit is operating.
- When working on this equipment, remain alert at all times. Never work on the equipment when you are physically or mentally fatigued.
- This generator set may be capable of automatic, unattended operation, and may start and run at any time. To prevent possible injury under such conditions, NEVER work on a generator in automatic mode. Before commencing work, select the control system to "OFF," disconnect generator starting battery and isolate any other sources of electrical power to the machine (such as battery charger or engine heater supplies).
- Before performing any maintenance on the generator set, disconnect its battery cables to prevent accidental start up. Disconnect the cable from the battery post indicated by a NEGATIVE, NEG or (-) first. When reconnecting the battery, connect the NEGATIVE, NEG or (-) last.
- Never use the generator or any of its parts as a step. Stepping on the unit can stress and break parts, and may result in dangerous operating conditions from leaking exhaust gases, fuel leakage, oil leakage, etc.
- Inspect the generator set regularly, and repair or replace all damaged or defective parts immediately.
- Remove the fuse from the battery charger before disconnecting the battery to minimize the chance of equipment damage.



- ⚠ For fire safety, the generator must be installed and maintained properly. Installation always must comply with applicable codes, standards, laws and regulations. Adhere strictly to local, state and national electrical and building codes. Comply with regulations the Occupational Safety and Health Administration (OSHA) has established. Also, ensure that the generator is set up in accordance with the manufacturer's instructions and recommendations. Following proper set up, do nothing that might alter a safe installation and render the unit in noncompliance with the aforementioned codes, standards, laws and regulations.
- Keep a fire extinguisher near to the generator set at all times. Extinguishers rated "ABC" by the National Fire Protection Association are appropriate for use on generator sets and are useful for small fires. For more sophisticated fire protection systems, contact your local fire department for advice, or contact a specialist fire protection company.
- ⚠ The generator set covered by this manual produces dangerous electrical voltages and can cause fatal electrical shock. Avoid contact with bare wires, terminals, connections, etc., while the unit is running. Ensure all appropriate covers, guards and barriers are in place before operating the generator set. If you must work around an operating unit, stand on an insulated, dry surface to reduce shock hazard.
- The National Electric Code (NEC) requires the frame and external electrically conductive parts of the generator set to be connected to an approved earth ground. Local electrical codes also may require proper grounding of the generator electrical system.
- Operation of the generator set in damp or wet locations can be extremely hazardous. Electrical resistance to current is reduced whenever items become wet.
- Never wear jewelry or watches when working on this equipment. Jewelry and watches can conduct electricity resulting in electric shock, or may get caught in moving components causing injury.
- ⚠ In case of accident caused by electric shock, immediately shut down the source of electrical power. If this is not possible, attempt to free the victim from the live conductor. **AVOID DIRECT CONTACT WITH THE VICTIM.** Use a nonconducting implement, such as a board or a rope, to free the victim from the live conductor. If victim is unconscious, apply first aid and get immediate medical help.
- ⚠ Do not smoke around the generator set. Wipe up any fuel or oil spills immediately. Ensure that no combustible materials are left on or near the generator set, as FIRE or Explosion might result. Keep the area surrounding the generator set clean and free from debris.
- Diesel fuel can be hazardous. Regularly inspect the installation for leaks and rectify them immediately.

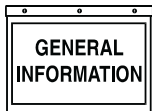

IDENTIFICATION RECORD

DATA PLATE

Every generator has a DATA PLATE which contains important information pertinent to the generator. The data plate lists the unit's serial number, its rated voltage, amps, wattage capacity, phase, frequency, rpm, power factor, etc.

Generator Model Number: This number is the key to numerous engineering and manufacturing details pertaining to your unit. Always supply this number when requesting service, ordering parts, or seeking information.

Voltage Code X: The GR Series generators are capable of supplying a variety of single-phase and 3-phase voltages, in total referred to as an X voltage code. They include the following:

- 120/208 to 139/240 volts, single phase, 60 Hz.
- 120/208 to 139/240 volts, 3-phase, 60 Hz.
- 240/416 to 277/480 volts, 3-phase, 60 Hz.

Note:

The above voltage ratings are stated in the form, V_{ph}/V_L .

— V_{ph} is the phase voltage (i.e., voltage above neutral).

— V_L is the line-to-line voltage.

EQUIPMENT DESCRIPTION

This equipment is a revolving field, alternating current generator set. The generator is designed to supply electrical power for the operation of compatible, electrical loads when Utility Power is unavailable.

The generator's revolving field is directly connected to and driven by an engine by means of flexible discs and a coupling assembly. Units with 4-pole rotors are driven at speeds of 1800 rpm to supply a rated frequency of 60 Hz.

The generator is mounted on highway transportable trailers equipped with breakaway safety chains and a jockey wheel. Weather-resistant, all-metal, sound-attenuated enclosures protect the generator against the elements while substantially reducing noise.

STANDARD GENERATOR FEATURES

This generator incorporates the following features:

- The unit meets temperature rise standards for Class "F" insulation as defined by NEMA MG1-22.40, NEMA MG1-1.65 and NEMA MG1-1-66.
- The generator is self-ventilated and drip-proof constructed.
- The voltage waveform deviation, total harmonic content of the AC waveform and "telephone influence factor" have been evaluated and are acceptable

according to NEMA MG1-22.

- A state of the art magnetic circuit provides minimal level of waveform distortion and an electro-magnetic interference level which meets accepted requirements for standard AM radio, TV and marine radio telephone applications.

GENERATOR SPECIFICATIONS

Refer to the DATA PLATE on your particular generator for rated watts (kW), rated maximum amperes, rated AC frequency, rated voltage, number of phases and other pertinent information.

ENGINE SPECIFICATIONS

General

- Type.....Diesel
- Cylinders and Arrangement.....6, in-line
- Displacement6.8 Liter (414 inches³)
- Bore106mm (4.19 inches)
- Stroke127mm (5 inches)
- Compression Ratio17.0 to 1
- Intake Air.....Turbo Charged
- No. of Main Bearings.....7
- Governed Engine SpeedSee DATA PLATE
- Maximum Horsepower at 1800 rpm.....166
- Engine Lubrication System
- Type of Oil Pump.....Gear
- Oil FilterFull Flow Cartridge
- Crankcase Oil Capacity.....17 liters (4.5 U.S. gallons)
- Cooling System
- Type.....Pressurized, closed recovery
- Coolant Capacity
- System.....17.8 liters (4.7 U.S. gallons)
- Engine.....11.3 liters (3 U.S. gallons)
- Radiator.....6.5 liters (1.75 U.S. gallons)
- Coolant Flow Per Minute
- At 1800 rpm.....174 liters (46 U.S. gallons)
- Heat Rejection to Coolant.....211,500 BTU/hr.
- Cooling FanPusher type
- Diameter of Fan.....559mm (22 inches)
- Intake Air Flow Required
- 60 Hz.11.5 m³/min. (406 cfm)
- Exhaust System
- 60 Hz.22.6m³/min. (798 cfm)
- Exhaust Temperature at Rated Output573°C (1,063°F)
- Engine Electrical System
- DC Alternator Output.....55 amps at 12 volts
- Starter Motor12 volt DC
- Recommended Battery(1) 12 volt, 135 A.H., 4DLT
- Ground PolarityNegative (-)

Fuel Consumption

Model	50%	75%	100%	Standby
GR125 at 60 Hz. (gph)	3.4	5.1	6.8	7.1
(liters per hour)	12.8	19.3	25.7	26.8

INSTALLATION

STANDBY ELECTRIC SYSTEM

A standby electric system may be defined as a system in which the generator is used to operate critical electrical loads normally powered by a utility power source when the utility power source fails or is not present.

- If you are going to use the units to operate electrical loads in standby system applications, the units may be used up to their rated capacity. If the total electrical power demanded by all loads in a system is greater than the rated limit, you can only power essential or key loads (up to the stated capacity).
- Generac does not recommend installing or operating a trailer mounted generator indoors. Other units are available which are better suited for indoor installations.
- A double throw transfer switch is required in standby electric system applications to prevent electrical feedback between the generator and the utility power circuit.
- Figure 1 illustrates a typical standby electric system. Figure 2 shows a schematic diagram of such a system. The transfer switch is used to select which power supply (generator or utility) will operate load circuits in such a system. The transfer switch also prevents load circuits from being connected to both power supplies at the same time.
- If the installer has not installed a transfer switch and modified the electric system as shown in Figure 2, plug critical electrical devices (furnace, fan, sump pump, water pump, etc.) directly into one of the generator's output receptacles.

- If the electrician has installed a transfer switch and a connection box, use a suitable, approved cord set between the connection box and a suitable generator receptacle, or between the connection box and the generator's full capacity terminal studs.



DANGER: If existing electrical circuits in a building are normally powered by the utility source, the installer must provide a positive means of making sure that both power supplies never feed to the load circuits at the same time.

- Never connect the generator output to any live building circuits. If the generator is connected to any existing electrical circuit during a commercial power outage, a positive method of isolating the two power supplies must be provided. The usual method of isolating the circuits is by means of a double throw transfer switch.

Figure 2 - Simple Standby Electric System

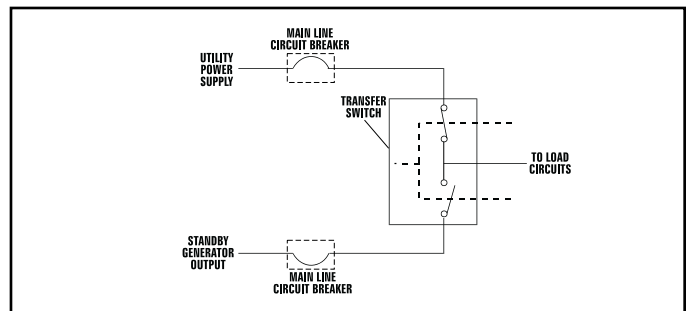
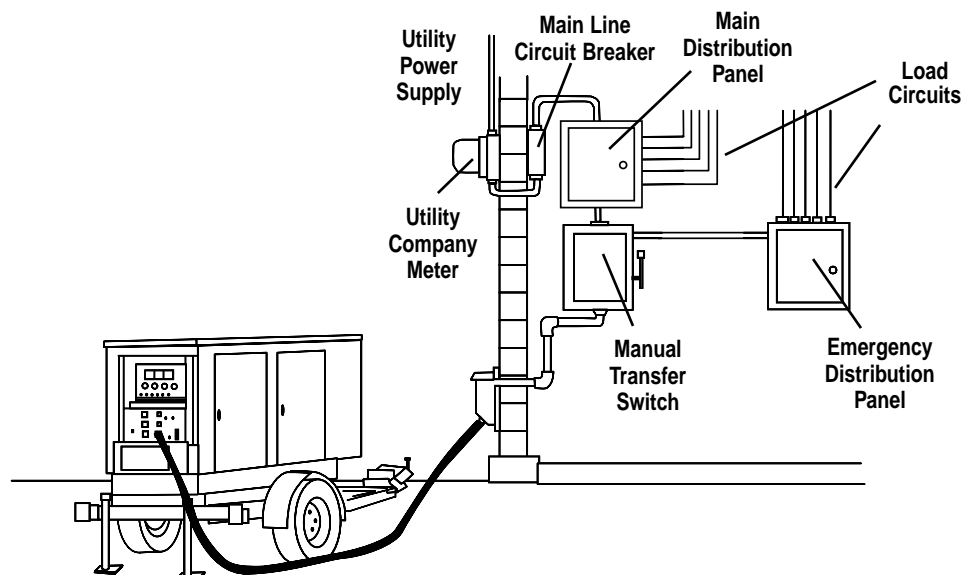

Figure 1 - Typical Standby Electric System





DANGER! A hazard exists during a power outage if the generator is connected to building circuits and no method of positively isolating the generator from the utility supply is provided.



Power company workers attempting to restore utility power will open a switch between the main power supply and the spot where they are working. If the home or building electrical circuits are not isolated from the utility supply, generator AC output will backfeed through the building electrical circuits and up the power line. A power company worker may be electrocuted.



If utility and generator power are not isolated and utility power is suddenly restored while the generator is powering load circuits, the generator can be severely damaged.

Figure 3 - Emergency Circuit Isolation

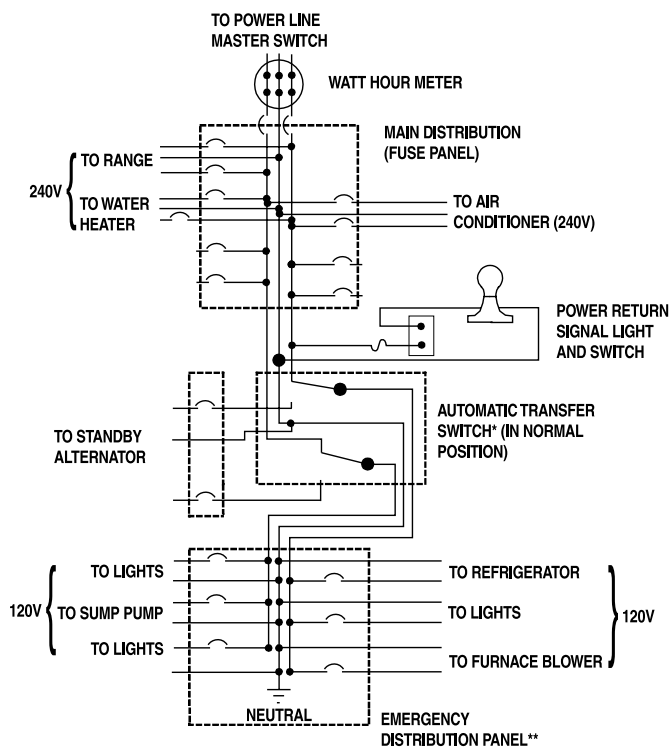

EMERGENCY CIRCUIT ISOLATION

One isolation method is to have emergency circuits (important or essential items to be powered during a utility outage) grouped together and rewired into a separate “emergency distribution panel” (Figure 3). Using this method helps prevent accidental overloading of the generator or the specific generator receptacle in use.

Loads fed by this emergency distribution panel must not exceed the wattage/amperage rating of the generator or the specific receptacle in use.

A transfer switch having an ampere rating equal to or exceeding the ampere rating of the emergency circuit should be connected between the building’s main electrical distribution panel and the emergency distribution panel.

* Ampere rating must be equal to or exceed the ampere rating of the emergency distribution panels.

** Ampere capacity not to exceed the alternator rating. Only these items will be powered by the standby alternator. If the electrician sizes the load properly, the alternator cannot be overloaded.

All wiring must conform to the United States National Electrical Code (NEC) and all state and local codes. Consult a qualified licensed electrician.

The above illustration assumes the utility is supplying 120/240 volt single phase electric service.

TOTAL CIRCUIT ISOLATION

If the emergency circuits (Figure 4) are not or cannot be wired together in a separate emergency distribution panel, you will have to select the circuits and specific appliances to be powered by the generator during a utility power failure. When this is done, take care to avoid overloading the generator or generator receptacles.

When using the total circuit isolation method, the ampere rating of the transfer switch must equal the rating of the normal incoming utility service.

Figure 4 - Total Circuit Isolation Method

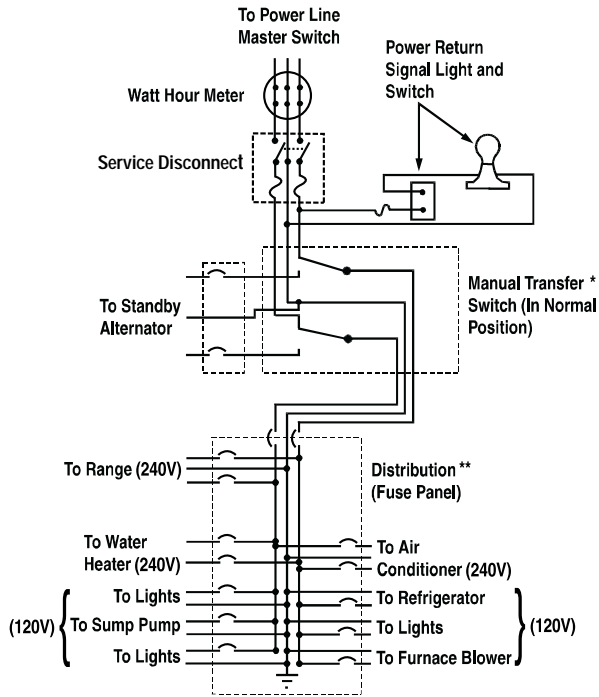

*Ampere rating must be equal to or larger than main (normal) utility entrance service.

**With this system take care to prevent overloading the alternator. During utility power failure, turn OFF individually all load items to distribution panel. Only certain items can be turned back on during alternator operation. Have your electrician specify these items so you do not overload the alternator. All wiring must conform to the United States National Electrical Code (NEC) and all state and local codes. Consult a qualified licensed electrician. The above illustration assumes the utility is supplying 120/240 volt single phase electric service.

PREPARATION BEFORE USE



CAUTION: Prior to initially starting the generator, you must properly prepare it for use. Any attempt to crank or start the engine before it has been properly serviced with the recommended oil may result in an engine failure. Also, engine coolant level must be checked and replenished if necessary.

ENGINE LUBRICATION

Check engine crankcase oil level prior to use and add oil to the proper level. See "Maintenance" section for recommendations.

ENGINE COOLANT

Check engine coolant level and add the recommended coolant mixture as required. Refer to "Maintenance" section.

FUEL

Fill the fuel tank with the correct recommended diesel engine fuel (see "Maintenance" section). The mounting base tank holds 64 gallons and the base tank holds 165 gallons of fuel.

NOTE: If the unit has been idle for a long period of time or if fuel lines or fuel system components have been removed and re-installed, the fuel system may require bleeding to remove air from the system. See "Maintenance" section for fuel system bleeding procedures. Air in the fuel system causes hard starting and rough engine operation. All fuel system lines must be installed and must be tight. A loose line may show no sign of leakage, but may draw air into the system.

CORD SETS - 120 VOLT GFCI DUPLEX RECEPTACLE



CAUTION: Panel receptacles can supply only single-phase AC output. Never connect any 3-phase electrical load to a receptacle.

The generator is equipped with a 120 volt ground fault circuit interrupter (GFCI) duplex receptacle on the generator receptacle panel (Figure 5). See "Ground Fault Protection" on Page 14. This outlet consists of a "pair" of receptacles, protected against overload by a 15-amp, push-to-reset type circuit breaker. Thus, you may use the receptacle pairs to power 120 volts, 60 Hz, AC electrical loads requiring up to 15 AC amperes of total current.

Figure 5 - 120 V, GFCI Duplex Outlet

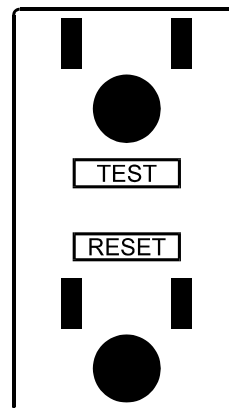

Use only high quality, well-insulated, 3-wire, grounded cord sets with the 120-volt duplex type receptacles. Cord sets should be rated 15 AC amperes at 135 volts or greater.

120 VOLT LOCKING TYPE RECEPTACLE



CAUTION: Panel receptacles can supply only single-phase AC output. Never connect any 3-phase electrical load to a receptacle.

This locking type receptacle (Figure 6) is protected against ground faults with a ground fault circuit interrupter (GFCI) module. See Ground Fault Protection on Page 14. It is also protected against overload by a 15-amp, push-to-reset type circuit breaker. The receptacle, a NEMA L5-20R type, requires a mating NEMA L5-20P connector plug. Use only high quality, well-insulated, 3-wire, grounded cord set with connector plug. The cord set must be rated for 15 AC amperes at 135 volts (or greater) electrical loads.

Figure 6 - 120 Volt, Locking Type Receptacle

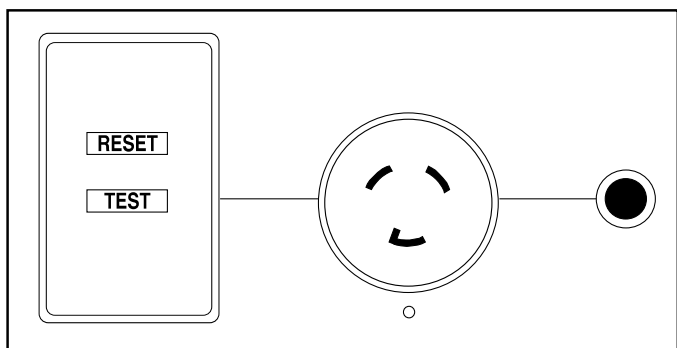

CAUTION: Any attempt to power total loads in excess of 15 amperes from the 120V receptacle pair, or the 120V locking type receptacle, will trip open a circuit breaker, blocking power to either receptacle.

120/208 TO 139/240 VOLTS, 50 AMP LOCKING TYPE RECEPTACLE



CAUTION: Panel receptacles can supply only single-phase AC output. Never connect any 3-phase electrical load to a receptacle.

Each of these receptacles are protected against overload by two separate 50 amp, flip-to-reset type circuit breakers. These receptacles are type CS6369 and require the proper mating plugs. Use only high quality, well insulated, 3-wire, grounded cord sets with mating 50 amp connector plugs. The cord sets used must be rated for 1-phase, 50 AC amps at 250 volts (or greater) electrical loads (Figure 7).

Figure 7 - 120/208 Volts, 50 Amp Receptacle

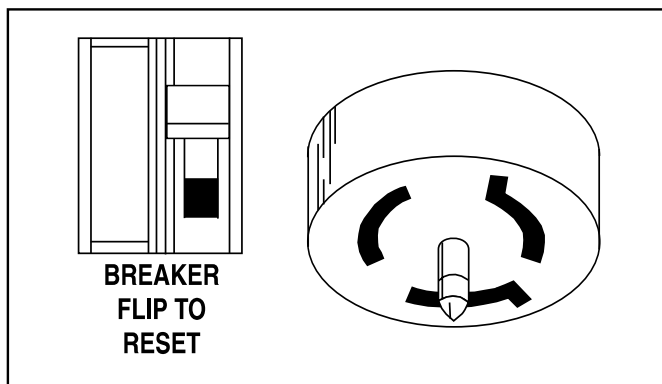

The voltage on this receptacle can be adjusted between 120/208 volts and 139/240 volts. Adjusting for 127/220 volts AC with the voltage adjustment dial is also acceptable for most 120/240 volts loads.



WARNING! Never unplug a connector plug from any panel receptacle while an electrical load is connected and turned on. Conversely, never plug a load in while that load is turned on. Dangerous electrical arcing can occur between the receptacle and the connector plug.

FULL CAPACITY TERMINAL COMPRESSION LUGS

Terminal compression lugs are provided in the two AC power panels (Figure 8). Four terminal studs in one panel are identified as N (neutral), E1, E2, and E3 high voltage connections. The studs for low voltage connections are labeled L1, L2, L3 and N in the second panel. These studs may be used to operate either single or 3-phase electrical loads at up to the full-rated wattage/amperage capacity for each mode of operation (1 phase or 3 phase). Terminal stud AC output is limited by the generator's 500 amp main circuit breaker (CB7) for 208 volts AC loads or the 200 amp main circuit breaker (CB8) for 480 volts AC loads.

Figure 8 - High Voltage Terminal Compression Lugs

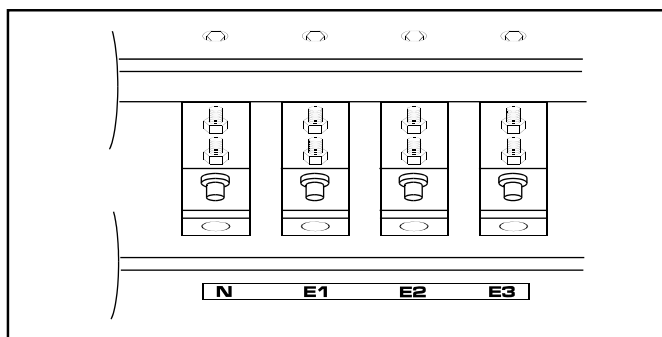



CAUTION: Although you can operate single-phase loads through the terminal lugs as well as the receptacles, **DO NOT** attempt to connect any 3-phase loads to the receptacles.

- Wiring cables for connecting loads to terminal studs must be rated 480 volts at 300 AC amperes (or greater) for loads on E1, E2, E3, N and 240 volts at 500 AC amps (or greater) for loads on L1, L2 L3.
- When connecting electrical loads, be sure the voltage adjust dial is positioned to the correct voltage. The dial permits you to adjust the voltage from 120/208 volts and 240/416 volts up to 139/240 volts and 277/480 volts.



CAUTION! Voltage adjust dial affects all receptacles and terminals at the same time.

NOTE:

All receptacles and terminals are available at all times and can be loaded at the same time. MAXIMUM TOTAL LOAD must not exceed generator rating. Maximum load for single-phase or three-phase operation must not exceed the rating for that particular mode of operation (rating for single-phase may be less than for three-phase operation). The total load connected to any phase, including loads connected to receptacles, must not exceed the rated generator output per phase.

- Set voltage adjust dial to “120/208V” for 120 volts, single-phase or 208 volts, 3-phase when connecting for one of these voltages. See “Voltage Adjust Dial” on page 12. Connect cord set leads as follows:
 - L1 to N = 120 volt, single-phase
 - L1 to L2 = 208 volt, 3-phase
 - L2 to N = 120 volt, single-phase
 - L2 to L3 = 208 volt, 3-phase
 - L3 to N = 120 volt, single-phase
 - L3 to L1 = 208 volt, 3-phase
- Set the voltage adjust dial to “139/240V” for 139 volt, single-phase or 240 volt, 3-phase when connecting for one of these voltages. See “Voltage Adjust Dial” on page 12. Then connect cord set leads as follows:
 - L1 to N = 139 volt, single-phase
 - L1 to L2 = 240 volt, 3-phase
 - L2 to N = 139 volt, single-phase
 - L2 to L3 = 240 volt, 3-phase
 - L3 to N = 139 volt, single-phase
 - L3 to L1 = 240 volt, 3-phase



WARNING! With voltage set line-to-line for 240V, line-to-neutral voltage will be 139V at receptacles.

- Set the voltage adjust dial to “240/416V” for 240

volt, single-phase or 416 volt 3-phase when connecting for one of these voltages. See “Voltage Adjust Dial” on page 12. Then connect cord set leads as follows:

- E1 to N = 240 volt, single-phase
- E1 to E2 = 416 volt, 3-phase
- E2 to N = 240 volt, single-phase
- E2 to E3 = 416 volt, 3-phase
- E3 to N = 240 volt, single-phase
- E3 to E1 = 416 volt, 3-phase
- Set the voltage adjust switch to “277/480V” for 277 volt, single-phase or 480 volt, 3-phase when connecting for one of these voltages. See “Voltage Adjust Dial” on page 12. Then connect cord set leads as follows:
 - E1 to N = 277 volt, single-phase
 - E1 to E2 = 480 volt, 3-phase
 - E2 to N = 277 volt, single-phase
 - E2 to E3 = 480 volt, 3-phase
 - E3 to N = 277 volt, single-phase
 - E3 to E1 = 480 volt, 3-phase



CAUTION: Do NOT connect E1 or E2 or E3 to L1 or L2 or L3. Damage to equipment, personal injury or death may result.



DANGER: Connect cable leads to the power terminal studs when the engine is shut down. The panel door is equipped with a push-button safety interlock switch (Figure 9) that prevents engine startup and operation while the door is open. Opening the door while engine is running immediately shuts down the engine. The switch is provided for your protection. Do not attempt to bypass or disconnect it.

TRANSFER SWITCH TERMINAL

The AC power panel includes a terminal strip for connecting an automatic transfer switch, such as a GTS transfer switch (Figure 10). This connection allows you to use the unit as a standby generator in practical applications or in emergency situations.

Figure 9 - Interlock Switch on Panel Door

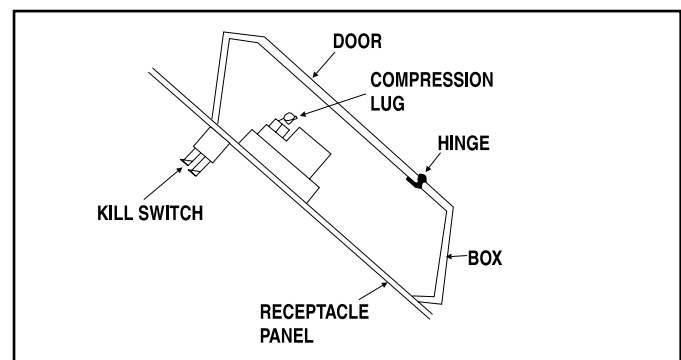
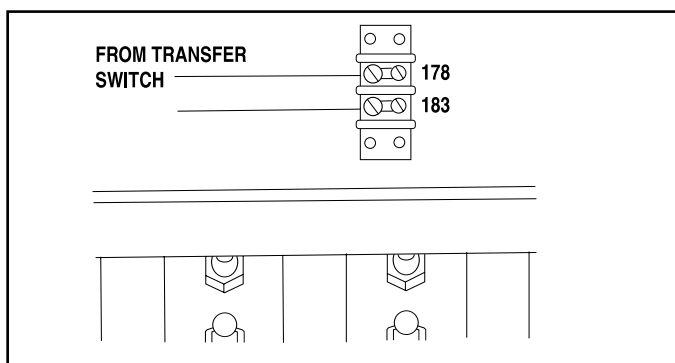

Figure 10 - Transfer Switch Terminals



AC VOLTMETER

This AC voltmeter indicates the voltages for generator AC output. Also see "Voltage Adjust Dial".

When connecting electrical loads, be sure the voltage adjust dial is positioned to the correct voltage. The voltage adjust dial permits you to adjust voltages from 120/208 volts and 240/416 volts up to 139/240 volts and 277/480 volts.

CAUTION! Voltage adjust dial affects all receptacles at the same time.

NOTE:

All receptacles and terminals are available at all times and can be loaded at the same time. MAXIMUM TOTAL LOAD must not exceed generator rating. Maximum load for single-phase or three-phase operation must not exceed the rating for that particular mode of operation (rating for single-phase may be less than for three-phase operation). The total load connected to any phase, including loads connected to receptacles, must not exceed the rated generator output per phase.

AC AMMETER

Indicates current draw of connected loads, in amps. Rated maximum continuous load current should be kept within the limits of the rated wattage capacity of the unit for single phase and for 3-phase loads.

STARTING BATTERY

Included is a 12 volt, Group 4D storage battery rated at 135 amp-hours. The battery was properly serviced and fully charged prior to installation.

- The red battery cable (from starter contactor) should be connected to battery post indicated by a positive POS or (+).
- The black cable (from frame ground) must be connected to the battery post indicated by a negative, NEG or (-).
- The battery must be properly retained in its mounting tray, using the hardware provided.

SWITCHES, METERS AND LIGHTS

For all the components mentioned in this section, refer to Figure 11.

Figure 11 - Generator Control Console

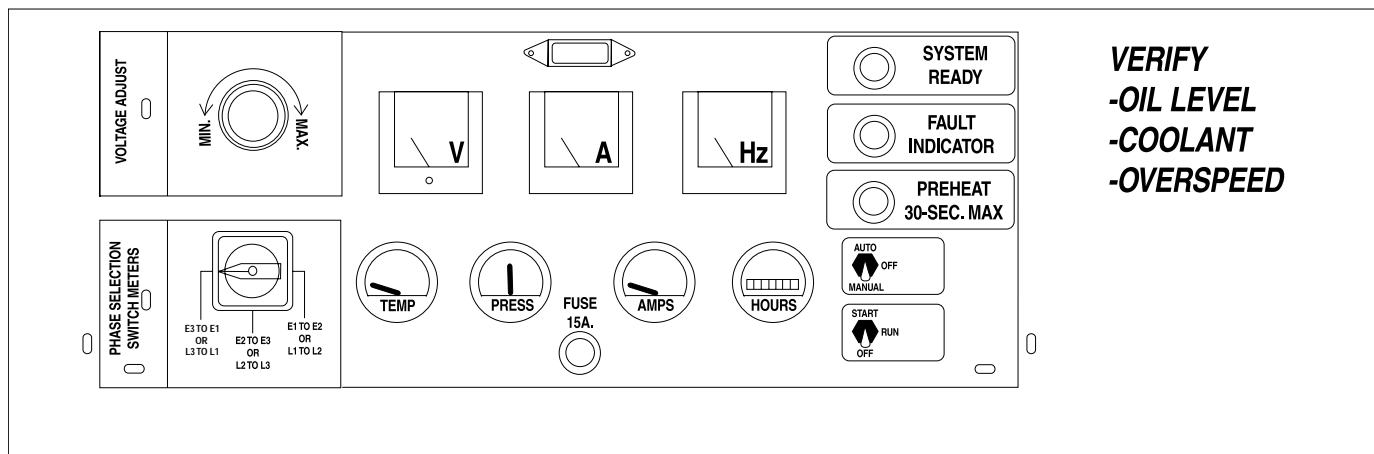

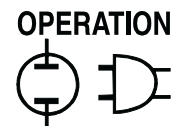

■ FREQUENCY METER

Indicates generator AC output frequency in “Hertz” (cycles per second). The generator's rated AC frequency is 60 Hertz, which is supplied at 1800 rpm. The engine governor was factory adjusted at no-load to about 1860 rpm or 62 Hertz. Maximum droop with the generator fully loaded should not be below about 58 Hertz. While operating, normal frequency is between 58-62 Hertz.

NOTE: The engine automatically shuts down and the fault indicator light goes ON if frequency exceeds about 74 Hertz (2220 rpm). This is an “overspeed” condition.

■ COOLANT TEMPERATURE GAUGE

Indicates engine coolant temperature. Coolant temperature during unit operation is about 170°-200°F. If the coolant temperature exceeds about 250°F, the engine automatically shuts down and the fault indicator light goes ON.

■ OIL PRESSURE GAUGE

Indicates engine oil pressure.

■ DC AMMETER

The engine is equipped with a belt-driven DC alternator which maintains battery state of charge while the unit is running. This ammeter indicates rate of charge to the battery while operating.

- Immediately after startup, the DC ammeter needle may swing to the right of zero (+ - charging) but should drop to zero or just slightly to the right of zero (+) within a few minutes.
- If the needle drops to the left of zero (or —), battery is discharging. Investigate and correct this problem immediately.
- If the ammeter needle fluctuates, investigate and correct immediately. Disconnect battery and control panel fuse prior to working on unit.

■ HOURMETER

Provides a continuous indication of engine-generator operating time, in hours and tenths of hours. Use the hourmeter with the periodic maintenance schedule (See “Maintenance” section).

■ FAULT INDICATOR

Lamp goes on if any one or more of the following automatic shutdown faults occurs:

- High coolant temperature (above about 250°F).
- Low coolant level.
- Low engine oil pressure (below 10 psi).
- Overspeed above about 74 Hz (2220 rpm).
- Overcrank

■ SYSTEM READY LAMP

This lamp goes ON when the unit is running. The lamp will not go ON if a fault has occurred and you have not set the Start/Run/Off switch to OFF to reset.

■ PRE-HEAT SWITCH

This engine comes with INTAKE AIR HEATERS to heat the combustion chamber air for quicker and easier starts. Prior to starting a cold engine manually, hold the PREHEAT switch for about 15 seconds. DO NOT PRE-HEAT FOR MORE THAN 30 SECONDS.

■ AUTO/OFF/MANUAL SWITCH

This safety switch should be used to prevent automatic startup of the engine when working on the engine-generator. Use the switch as follows:

- AUTO Position: Always set switch to AUTO for automatic system operation. This means when this generator is installed along with a GTS type automatic transfer switch, the generator automatically cranks and starts when the utility source voltage drops below a preset level. See “Engine Control Operation”.
- OFF Position: Engine cannot be started either automatically or manually. Always set switch to OFF before working on or around the engine-generator.
- MANUAL Position: Engine can be cranked and started manually using the panel Start/Run/Off switch. Engine will not start automatically.

■ START/RUN/OFF SWITCH

To crank and start the engine, hold the Start/Run/Off switch at “Start”. When engine starts and runs at rated frequency, release the switch to its center (Run) position. To shut engine down, set the switch to the “Off” position.

OPERATION

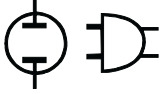

Operation

GR-125 Generator Set

■ PANEL LIGHT

The panel light will turn on when the unit is running or cranking.

■ VOLTAGE ADJUST DIAL

This potentiometer permits the operator to select the desired output voltage from the alternator. Turning the voltage adjust dial counterclockwise decreases the voltage and allows operation of loads down to 120/208 volts AC and 240/416 volts AC and a little below.

Turning the dial clockwise, the unit can operate up to 139/240 volts and 277/480 volts AC and slightly higher loads. The generator can power any load with voltage between these two extremes including 127/220 volts AC near the center of the dial.

Note: The voltage indicated on the voltage adjust dial is line-to-line voltage (See “Voltage Code X” on page 4).



CAUTION! Voltage adjust dial affects all receptacles and terminals at the same time.

NOTE:

All receptacles and terminals are available at all times and can be loaded at the same time. MAXIMUM TOTAL LOAD must not exceed generator rating. Maximum load for single-phase or three-phase operation must not exceed the rating for that particular mode of operation (rating for single-phase may be less than for three-phase operation). The total load connected to any phase, including loads connected to receptacles, must not exceed the rated generator output per phase.

■ PHASE SELECTION SWITCH

This switch permits selections between the phases for which the line-to-line voltage and amperage readings are displayed on the console AC voltmeter and ammeter.

ENGINE PROTECTIVE DEVICES

Unlike an automobile, the generator may be required to run for long periods without an operator nearby to monitor engine parameters (oil pressure, temperature, engine speed, etc.). For that reason, the unit is equipped with various protective devices which will stop the engine automatically if an operational fault occurs.

■ LOW OIL PRESSURE SWITCH

This normally-closed, pressure actuated switch (Figure 12) is held open by engine oil pressure during running. Should engine oil pressure drop below about 10 PSI, the switch contacts will close. When contacts close, the engine automatically shuts down and the fault indicator lamp goes ON.

12 Generac® Power Systems, Inc.

Figure 12 - Low Oil Pressure Switch

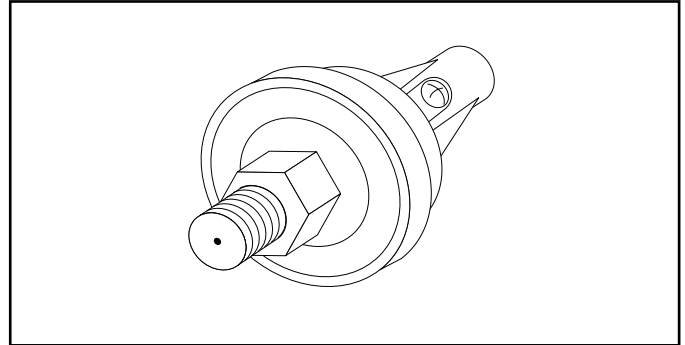

■ HIGH COOLANT TEMPERATURE SWITCH

This thermostatic, normally-open switch (Figure 13), is immersed in engine coolant. Should coolant temperature increase above about 250°F, the switch contacts close and an automatic shutdown occurs.

Figure 13 - High Coolant Temperature Switch

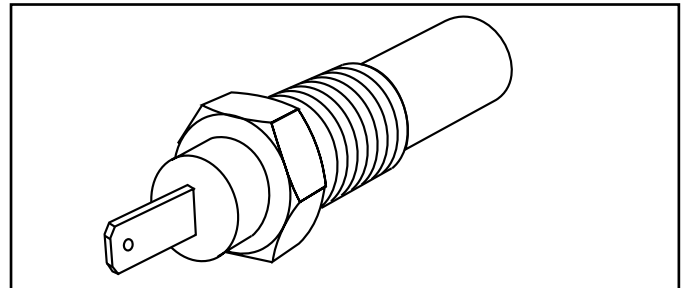

■ LOW COOLANT LEVEL SENSOR

If engine coolant level is low, a high temperature condition can exist without affecting the high coolant temperature switch. However, the low coolant level sensor (Figure 14) will detect the low level condition and initiate an engine shutdown.

Figure 14 - Low Coolant Level Sensor

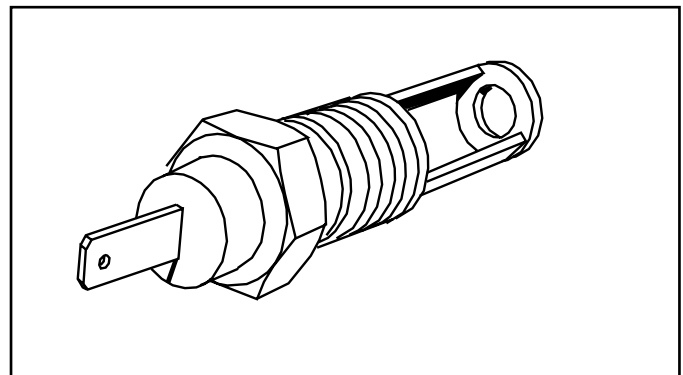

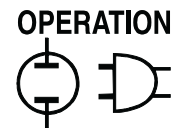

■ DC CONTROL/LATCH-CRANK CIRCUIT BOARD

The circuit board, housed inside the generator control console, controls engine starting, running and shut-down. The board provides either manual (electric) or automatic starting. It senses the generator is running by means of generator AC output.

■ ENGINE STARTUP

When the engine starts, the starter is disabled when AC output reaches about 40 volts AC (rms). Engine speed at that point has reached between 1000 to 1250 rpm.

A nominal 5-second time delay after starter cutout is provided. That is, if any one or more of the shutdown faults (low oil pressure, high coolant temperature, low coolant level, etc.) occurs 5 seconds or more after the starter cutout has occurred, the engine shuts down and the fault indicator lamp goes ON after the fault has been maintained for 2 seconds.

■ AFTER FAULT SHUTDOWN

You cannot start the engine until engine control is reset, following an automatic fault shutdown with the fault lamp ON. You can reset the control by setting the Start/Run/Off switch to "Off" and then back to the centered (Run) position.

■ OVERSPEED

A speed circuit controls engine cranking, start-up, operation and shutdown. Engine speed signals are delivered to the circuit board whenever the unit is running. Should the engine overspeed above a safe, preset value, the circuit board initiates an automatic engine shutdown.

■ OVERCRANK SHUTDOWN

If the engine fails to start after a crank cycle of 90 seconds (8 seconds on, 8 seconds off), this function will illuminate the fault indicator and stop the crank cycle.

OPERATING INSTRUCTIONS

■ BEFORE STARTING

- Prior to starting the engine, make sure the engine-generator has been properly prepared for operation as outlined in PREPARATION BEFORE USE (Pages 7-10).
- Check that both of the power panel (compression lug) doors are closed and latched. Engine will not start if any power panel door is open (Figure 9 on page 9).
- Check that the Voltage Adjust Dial is adjusted for the proper voltage that your loads require.

■ STARTING THE ENGINE

- Be sure all necessary cables are connected to the full capacity compression lugs before starting the engine (see pages 8-9). ALL electrical loads must be switched off before starting the engine (including loads connected to the receptacle panel).
- Place the Auto/Off/Manual switch in "Manual" position.
- Crank the unit by moving the Start/Run/Off switch to "Start".
- When engine starts and runs at rated Hz, release the start switch to the "Run" position.
- Let the engine stabilize and warm up for a few minutes. Then turn on the desired electrical loads.

NOTE:

During starting, the fault indicator lamp remains ON until oil pressure builds. If any monitored shutdown occurs, you cannot restart the engine until you reset the controls. To do this, set the Start/Run/Off switch to "Off" and then back to "Run."

■ SHUT DOWN

- Turn all loads OFF.
- Let the engine run at no-load for a few minutes to stabilize internal engine temperatures.
- On the generator control console, set the Start/Run/Off switch to "Off". Wait for the engine to come to complete stop.

■ OPERATION IN ICE OR SNOW

If the generator has been exposed to freezing rain or snow, be sure to inspect the air inlet and outlet areas in the compartment. Do not operate the unit if snow or ice have blocked or obstructed the air openings.

The generator is equipped with a "pusher" type cooling fan. This type of cooling fan draws air into the generator, then expels the air outward through the engine radiator. If cooling air flow is obstructed, the engine-generator may overheat.

■ GROUNDING THE GENERATOR

The National Electric Code (NEC) requires that the frame and external electrically conductive parts of the generator be properly connected to an approved earth ground. Local electrical codes may also require that you ground the unit. Consult with a local electrician for grounding requirements in your area.

Grounding helps prevent dangerous electrical shock if a ground fault exists in the generator or connected electrical devices. Grounding also helps dissipate static electricity that often builds up in ungrounded devices. Static electricity alone can cause very painful shock and may cause one to believe that a shorted condition exists in equipment.

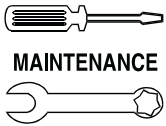

■ GROUND FAULT PROTECTION

The generator is equipped with a 120 volt duplex receptacle, and a 120V locking type receptacle. Each of these receptacles incorporates a Ground Fault Circuit Interrupter (GFCI) rated at 20 amps. These devices meet standards with applicable federal, state and local codes.

The GFCI protects you against electrical shock that may be caused if your body becomes a path through which electricity travels to reach ground. This could happen if you touch an appliance or cord that is "live." You don't even have to be on the ground, you could be touching plumbing or other material that leads to ground.

When protected by a GFCI, a person will still feel a shock, but the GFCI should cut it off quickly enough so a person in normal health should not have a serious electrical injury (Infants and very small children could still be affected).



WARNING! THE GFCI WILL NOT PROTECT YOU AGAINST THE FOLLOWING SITUATIONS: (1) LINE-TO-LINE SHOCKS (such as shocks from touching metal in both straight slots of an outlet); (2) CURRENT OVERLOADS OR LINE-TO-LINE SHORT CIRCUITS. THE FUSE OR CIRCUIT BREAKER AT THE DISTRIBUTION PANEL MUST PROVIDE SUCH PROTECTION.

Testing the GFCI: Test your GFCI outlets every month. Follow these instructions:

1. Push the black TEST button. Red RESET button should pop out from inner surface, which should allow no power to reach the outlet. Use a test lamp in each outlet.



CAUTION! If RESET button does not pop out or test lamp remains lit when RESET button does pop out, DO NOT USE ANY OUTLETS ON THE CIRCUIT. CALL A QUALIFIED ELECTRICIAN.

2. If the GFCI tests good, restore power by pressing the RED RESET button. THE RESET BUTTON MUST BE PUSHED FIRMLY AND FULLY INTO PLACE UNTIL IT LOCKS AND REMAINS IN THAT POSITION. IF THE GFCI DOES NOT RESET PROPERLY, DO NOT USE THE OUTLET — CALL A QUALIFIED ELECTRICIAN. Test lamp should go ON.
3. If the GFCI trips by itself at any time during or after installation, reset and perform steps 1 and 2. IF RESET BUTTON DOES NOT POP OUT WHEN TEST BUTTON IS PRESSED, DO NOT USE THE OUTLET. CALL A QUALIFIED ELECTRICIAN.

NOTE: Each 120 volt receptacle is protected with a 15 amp circuit breaker. The maximum total current from each receptacle is limited to 15 amps (See "Cord Sets - 120 Volt GFCI Duplex Receptacle" on pages 7 and 8, and "120 Volt Locking Type Receptacle on page 8).

MAINTENANCE

It is the owner's responsibility to perform all safety checks; to verify all required maintenance is performed for safe operation; and to have the equipment checked periodically by an authorized service technician. Normal maintenance service and replacement of parts are the responsibility of the owner/operator and, as such, are not considered defects in workmanship or material under the terms of the warranty.

Individual operating habits and equipment usage contribute to the need for maintenance service. Proper maintenance and care of your generator will help keep the number of problems and overall operating expenses at a minimum. Contact an authorized Generac Power Systems dealer/distributor or contact the factory for service aids.

■ 100-HOUR BREAK IN PERIOD

After the first 100 hours of operation, contact an authorized service facility for the following maintenance. The generator owner is responsible for all charges.

- Change engine oil and filter.
- Check all fluid levels.
- During break in, don't add oil until level is at the bottom of the crosshatching on dip stick.
- Inspect cooling system hoses for leaks, loose or defective clamps, and for damage or deterioration.
- Check the fuel system for leaks, condition, and tightness of fuel lines.
- Check the engine for proper operation.
- Check generator AC output. Make sure voltage and frequency are correct.
- Check the unit battery for proper electrolyte fluid level, proper state of charge, and condition.
- With engine running, note readings of all gauges and instruments.

■ 100-HOUR BREAK IN

The first 100 hours is the break in period. Correctly breaking in the engine-generator is essential to minimize oil consumption and maximize engine performance. During break in, observe the following rules.

- For the 100 hours of operation, avoid light electrical loads. Load the unit at 50% or more of its capacity during this period. Repeated light loads during break in can cause improper seating of the engine piston rings, resulting in blowby and high oil consumption after prescribed break in period.
- Check engine oil level frequently during break in. It is normal for oil consumption to be higher than normal during this period. The proper break in oil is John Deere's P/N TY22014.

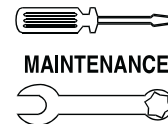

- After the 100-hour break in, complete the tasks recommended under “100-Hour Break In Period”.
- If continuous light loads are applied to unit during break in period, run unit for another 100 hour break in period with the recommended engine oil.

RECOMMENDED ENGINE FLUIDS

ENGINE OIL

Use a high quality detergent oil having API classification “For Service CF-4 or CG-4” or oils conforming to CCMC-D5 or CCMC-D4 specifications.

Consider the ambient temperature when selecting the viscosity of lubricating oil for your engine. Use the following chart to determine the oil you use:

AMBIENT TEMPERATURE	OIL RECOMMENDATION
-40° to 30°C (-40° to 86°F)	SAE 0W-30
-30° to 30°C (-22° to 86°F)	SAE 5W-30
-20° to 40°C (-4° to 104°F)	SAE 10W-40
-15° to 50°C (5° to 122°F)	SAE 15W-40
0° to 30°C (32° to 86°F)	SAE 30
10° to 50°C (50° to 122°F)	SAE 40
API Service Certification	CG-4 or CF-4

NOTE:

Multi-viscosity diesel engine oils are preferred. If diesel fuel with sulfur content greater than 0.5% is used, reduce the service interval by 50%.

ENGINE COOLANT

The use of coolant products, as outlined is strongly recommended.

Coolant products to use are silicate ethylene glycol base coolants for heavy-duty diesel engines. Use when mixed with quality water and supplemental coolant additives (SCAs), if they meet the following specifications:

- ASTM D5345 (prediluted coolant)
- ASTM D4985 (coolant concentrate) in a 40% to 60% mixture of concentrate with quality water.

Coolants meeting these specifications require addition of supplemental coolant additives (SCAs), formulated for heavy-duty diesel engines, for protection against corrosion and cylinder liner erosion and pitting.

IMPORTANT:

Never use automotive-type coolants (such as those meeting ASTM D3306 or ASTM D4656). These coolants do not contain the correct additives to protect heavy-duty diesel engines. They often contain a high concentration of silicates and may damage the engine or cooling system.

SUPPLEMENTAL COOLANT ADDITIVES

The recommended coolant additive is John Deere’s P/N TY16005 (or compatible) Liquid Coolant Conditioner.

IMPORTANT:

DO NOT over-inhibit antifreeze solutions, as this can cause silicate-dropout. When this happens, a gel-type deposit is created which retards heat transfer and coolant flow causing engine to over-heat.

Operating without proper coolant additive will result in increased corrosion, cylinder liner erosion and pitting, and other damage to the engine and cooling system. A simple mixture of ethylene glycol and water WILL NOT give adequate protection.

The use of supplemental coolant additives reduces corrosion, erosion, and pitting. These chemicals reduce the number of vapor bubbles in the coolant and help form a protective film on cylinder liner surfaces. This film acts as a barrier against the harmful effects of collapsing vapor bubbles.

Inhibit the antifreeze-coolant mix with a non-chromate inhibitor.

IMPORTANT:

Check inhibitors between drain intervals (every 600 hours or 12 months) of operation. Replenish inhibitors by the addition of a supplemental coolant additive as necessary. DO NOT use soluble oil.

FUEL

Use clean, fresh, No. 2D diesel fuel having a minimum Cetane Number “40” and conforming to ASTM* specifications.

*ASTM — American Society of Testing and Materials

CHECKING FLUID LEVELS

ENGINE OIL

Check engine oil level at least once daily (prior to use) or at least every 8 hours of operation, whichever comes first. The following rules apply:

- When checking oil level, the generator should be sitting on a level surface.
- Always check oil level BEFORE starting the engine, or wait at least 30 minutes after the engine is shut down.
- Avoid mixing different brands or different types of oil.
- The higher pressures and hotter temperatures in a diesel engine require that you use only Class CF-4 or CG-4 oil.

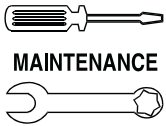

MAINTENANCE

Maintenance

GR-125 Generator Set

- Never operate the engine with oil below the cross-hatching on dipstick.
- Never overfill the engine crankcase above the dipstick crosshatching.
- To check oil level, remove dipstick and wipe dry with a clean cloth. Then, re-insert dipstick into dipstick tube and remove again. Oil should be between the top of the crosshatching and “ADD” marks. Add oil as required.

■ ENGINE COOLANT

Maintaining adequate concentrations of glycol and inhibiting additives in the coolant is critical to protect the engine and cooling system against freezing, corrosion, and cylinder liner erosion and pitting.

Test the coolant solution at 600 hours or 12 month intervals and whenever excessive coolant is lost through leaks or overheating to ensure the necessary protection. If coolant level in radiator or recovery bottle is low, proceed as follows:

- Inspect the radiator cap gasket for wear or damage. Replace cap, if necessary.
- Have the radiator pressure cap tested at an automotive repair facility or at an authorized Generac service facility.
- Check cooling system hoses and radiator for leaks.

NOTE:

When working properly, the coolant recovery system keeps the radiator coolant at the proper level. The radiator cap is equipped with both a pressure relief and a vacuum relief valve. When hot radiator coolant expands, excess coolant opens the pressure relief valve and drains into the coolant recovery bottle. After shutdown, as coolant mixture in the radiator cools, it contracts to form a vacuum. The vacuum relief valve then opens, to draw coolant from the recovery bottle and return it to the radiator. The coolant recovery bottle must be kept filled to the proper level to maintain radiator coolant at the proper level.

■ FUEL

Check fuel quantity at least once daily (every eight hours) and prior to use. The base-mounted fuel tank is equipped with a float operated fuel level gauge. Fill tank when level is between half full and 1/4 full.

IMPORTANT:

NEVER PERMIT THE ENGINE TO RUN OUT OF FUEL. IF ENGINE RUNS OUT OF FUEL OR IF FUEL LEVEL IN TANK DROPS TOO LOW, AIR WILL ENTER FUEL SYSTEM LINES AND CAUSE SERIOUS PROBLEMS, SUCH AS HARD STARTING AND ROUGH, ERRATIC OPERATION. YOU MUST BLEED THE ENGINE FUEL SYSTEM WHEN IT RUNS OUT OF FUEL.

OWNER/OPERATOR PERIODIC MAINTENANCE

Some maintenance tasks may be beyond the capability of the owner/operator and should be accomplished by a competent, qualified service technician. The owner/operator may accomplish the following:

- Check the engine oil level once daily; more often during the 100-hour break in period.
- Check the tire pressure before using and at least once each week thereafter. Keep the tires properly inflated according to tire specifications.
- Inspect entire fuel system once each month. Look for leaks, damage, loose lines, etc.
- Inspect engine drive belts prior to initial use and once each month thereafter. Replace any belt that is worn, cracked weathered, or otherwise damaged. Check and adjust belt tension. Consider tension correct when applying thumb pressure midway between pulleys causes a belt deflection of about 3/8 to 3/4 inch.
- Check battery electrolyte fluid level once each week. Add distilled water, if needed. Also inspect battery posts, cables and terminals for tightness, cleanliness, corrosion. Clean and tighten as required.
- Drain water and sediment from the optional spin-on fuel filter once each week (if so equipped).
- Start and exercise the unit at least once each week. Run the engine for at least 30 minutes during this exercise period.
- Keep the unit clean and as dry as possible. Use a mild detergent and water to clean exterior surfaces. Areas with paint damage should be cleaned, dried and repainted as necessary. An automotive type of paint may be used on the outside of the compartment.

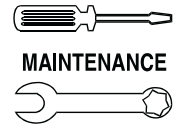

BLEEDING THE FUEL SYSTEM

The fuel system for this engine has a self-bleeding function, so air should not enter the fuel lines unless the engine has been disassembled for any reason. Bleeding air from the fuel system involves manually actuating the fuel lift pump.

PERIODIC MAINTENANCE LIST

The following maintenance tasks should be performed by an authorized service facility at these periodic intervals.

■ DAILY

- Check engine oil and coolant level.
- Check air cleaner dust valve & restriction indicator, replace filter (as required).
- Visual Walk around inspection.
- Inspect AC power cables and cord sets.

■ EVERY 50 HOURS OR 2 WEEKS

- Check fuel filter.

■ EVERY 250 HOURS

- Check battery state-of-charge and condition, service as necessary.
 - Change engine oil and replace filter.**
- **Change the oil for the first time after 100 hours maximum of (break-in) operation, then every 250 hours thereafter.

■ EVERY 600 HOURS OR 12 MONTHS

- Clean crankcase vent tube.
- Check air intake hoses, connections & system.
- Replace spin-on fuel filters.
- Check automatic belt tensioner and belt wear.
- Check cooling system.
- Coolant Solution analysis-add SCAs as needed.

■ EVERY 1200 HOURS OR 24 MONTHS

- Adjust droop on generator set engine.
- Pressure test cooling system.
- Flush cooling system.
- Check operation of engine protective devices (low oil pressure, high coolant temperature, low coolant level, overspeed).

■ EVERY 2000 HOURS

- Check and adjust engine valve clearance.
- Retorque engine intake manifold bolts.
- Retorque engine exhaust manifold bolts.
- Check injection timing.
- Check/inspect injection nozzles.
- Check engine compression pressure.

ADJUSTMENT OF FUEL INJECTION TIMING

A diesel engine does not have an electrical ignition system like those used on gaseous or gasoline-fueled engines. The diesel fuel is ignited by the heat of compression when the piston moves upward on its compression stroke. The engine firing is timed by precisely timing the injection of fuel into each cylinder at the proper moment. If the unit's injection system appears to be "out of time," have the engine checked and adjusted by an authorized diesel engine service facility. Do not attempt to adjust ignition timing without proper tools, test equipment and general knowledge of the product.

ENGINE SPEED ADJUSTMENT

The engine speed is controlled either with a mechanical governor or electronically.

The mechanical, fixed speed governor is part of the fuel injection pump. The governor was factory set to maintain 62 Hertz (1860 RPM) with no electrical loads applied. Under full rated wattage/amperage capacity, frequency may droop to about 59-60 Hertz.

The electronic governor has a solid-state design for the controller circuit board and actuator. This design results in fast, stable engine response to load changes. The controller board was factory set to maintain the unit's rated speed of 1800 rpm to achieve a frequency of 60 Hertz.

If the engine speed controller on the generator needs adjusting, contact an authorized service facility. They will have the proper equipment and trained personnel to complete all necessary adjustments.

**** Contact your nearest Generac/Guardian Authorized Dealer for assistance.**

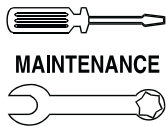

MAINTENANCE

Maintenance

GR-125 Generator Set



WARNING! Do not adjust the engine governed speed without proper equipment and know-how. The governed speed was factory set and should require no additional adjustment. Excessively high speeds are dangerous and increase the risk of personal injury or damage to equipment and/or property. Correct AC frequency and voltage are supplied only at the correct governed speed. Some connected electrical devices are extremely sensitive to frequency and voltage, and may be damaged by incorrect frequency and/or voltage. Operation of the unit at excessively low speeds imposes a heavy load on the engine when sufficient engine power is not available and may shorten engine life.

NOTE:

Generally, if AC frequency and voltage are both correspondingly high or low, the engine governor requires adjustment. If AC frequency is correct but voltage is not, the voltage regulator requires adjustment or some other problem exists.

VOLTAGE REGULATOR ADJUSTMENT

The generator's AC voltage regulator has been factory set to allow an operator to select proper voltage via the voltage adjust dial. If the voltage regulator on the generator needs adjusting, contact an authorized service facility. Only qualified service technicians should adjust voltage regulators.

GENERATOR ROTOR BEARING

The generator rotor is attached to the engine drive shaft at one end. The opposite end of the rotor rides in a pre-lubricated and sealed ball bearing that requires no additional lubrication for the life of the bearing.

MAJOR REPAIRS

Proper and regular maintenance of the generator is needed to make sure the generator has a long and trouble-free life. Only a qualified, competent generator service technician should perform all major generator service, including installation and replacement of factory approved repair parts. Only qualified, competent diesel engine repair facilities should service the engine, using only factory approved parts.

This section or your OWNER'S MANUAL consists of EXPLODED VIEWS pertaining to the generator and its engine, along with PARTS LISTS for the EXPLODED VIEWS. The PARTS LISTS consist of (a) an item number, (b) quantity required, (c) a part number and (d) a description of the part. The ITEM NUMBER relates to an identical number in the EXPLODED VIEW.

HOW TO ORDER PARTS

To order a replacement part, locate the part in the applicable EXPLODED VIEW in this manual. Provide the dealer/distributor with the following information:

- Generator BUILD NUMBER (from the unit data plate).
- Part NUMBER and DESCRIPTION (from the applicable PARTS LIST in this manual).
- The applicable exploded view DRAWING NUMBER.

Electrical Data
GR-125 Generator Set

Wiring Diagram – Control Panel – Drawing No. 090118-B

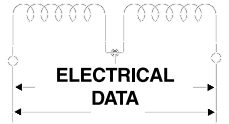

- AM – AMMETER, AC
- BCA – AMMETER, BATTERY CHARGER
- CBI – CIRCUIT BREAKER – FIELD
- D1 – DIODE 600V 12 AMP
- EC – ENGINE CONTROL
- F1 – FUSE 15 AMP
- G1 – GAUGE, WATER TEMPERATURE
- G2 – GAUGE, OIL PRESSURE
- HM – HOURMETER
- HZ – FREQUENCY METER
- L1 – LAMP, FAULT
- L2 – LAMP, PANEL
- L3 – LAMP, RUN
- PHR – PREHEAT RELAY
- RI – POTENTIOMETER, VOLTAGE ADJUST
- D2 – RECTIFIER 800V 2A
- R3 – RESISTOR – ENG. ALTERNATOR
- R4 – RESISTOR, FIELD BOOST
- SW2 – SWITCH, START/RUN/STOP
- SW3 – SWITCH, PREHEAT
- SW5 – SWITCH, PHASE SELECTOR
- SW6 – SWITCH, AUTO/OFF/MANUAL
- TB – TERMINAL BLOCK
- VM – VOLTMETER, AC
- VR – VOLTAGE REGULATOR

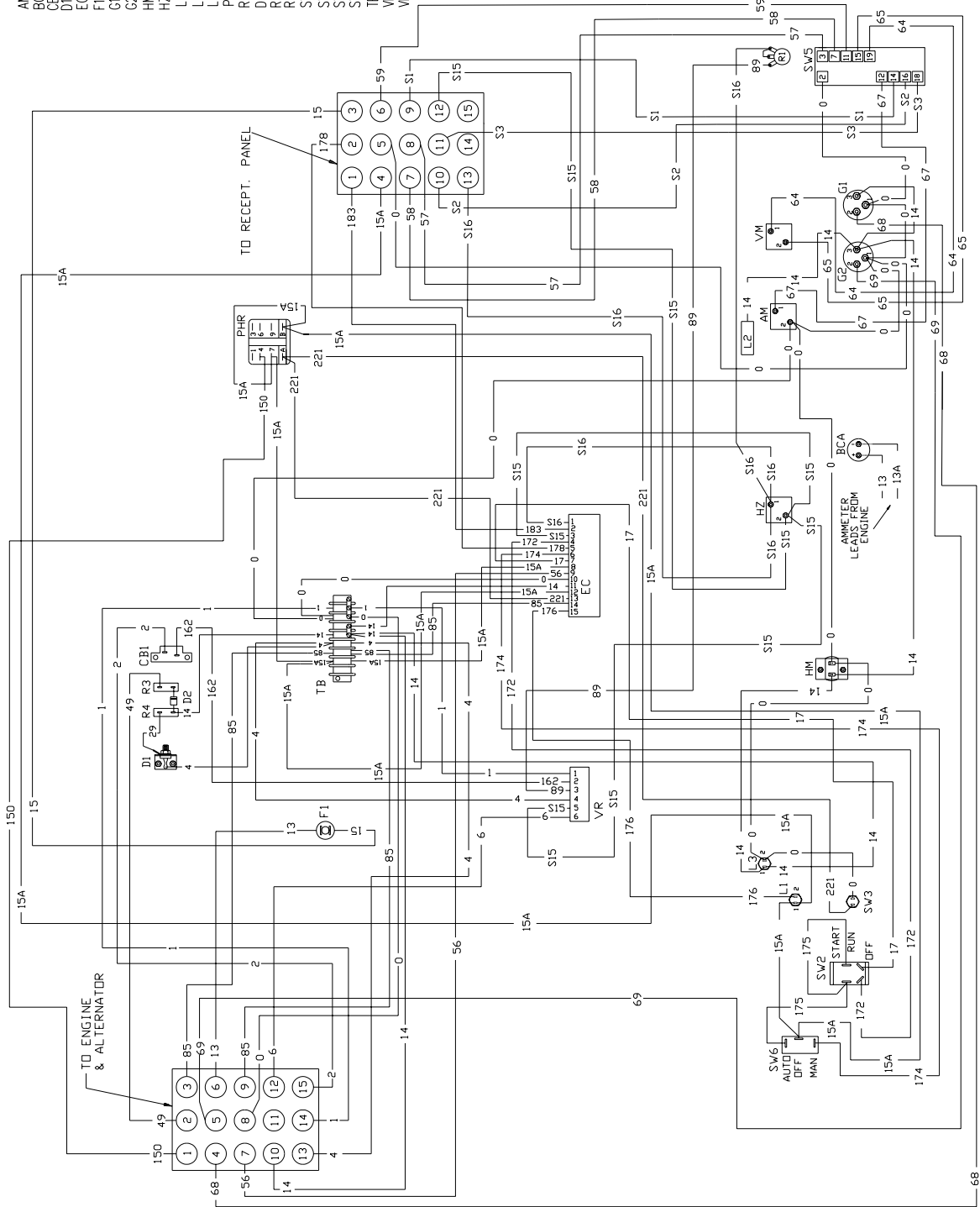

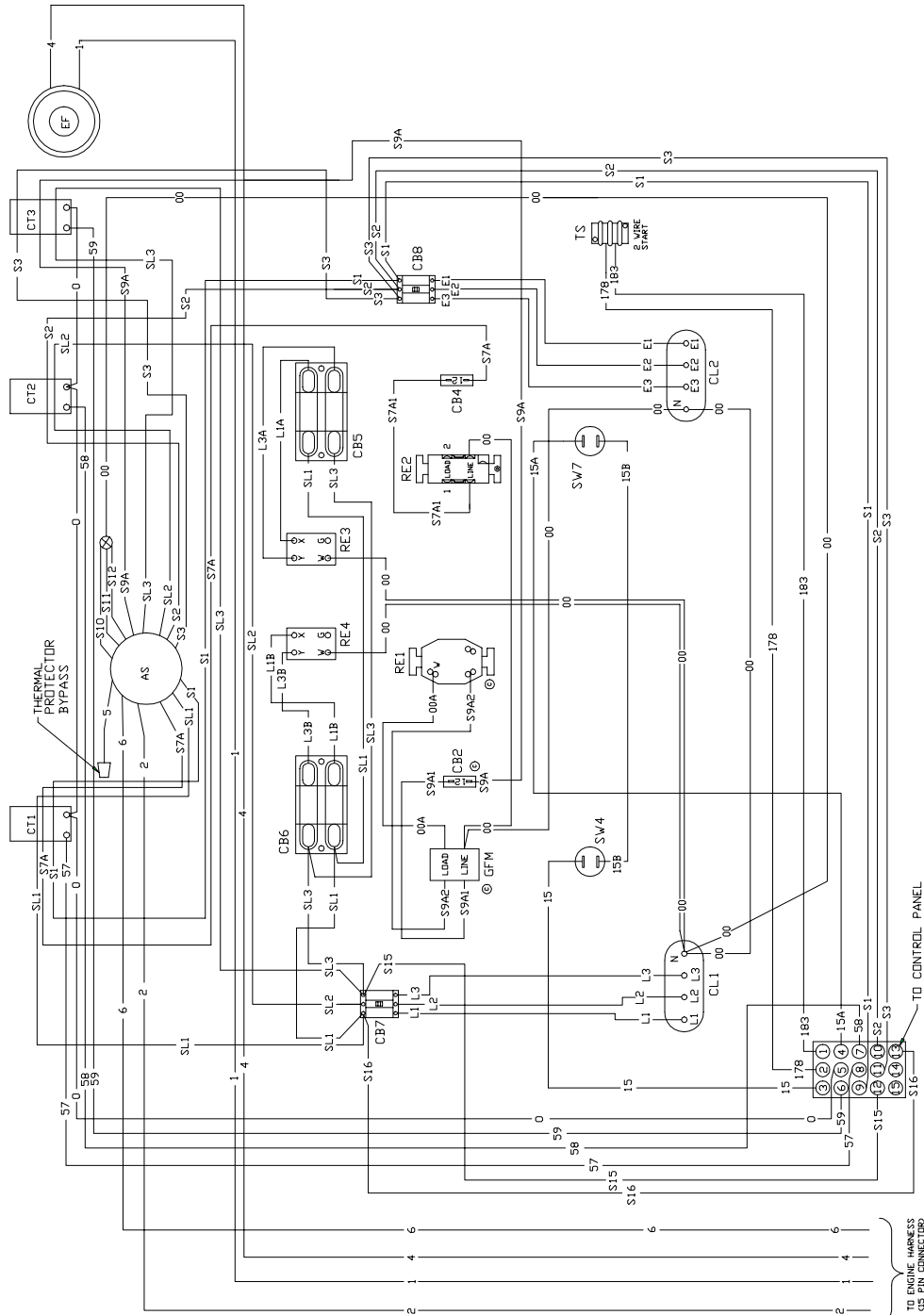
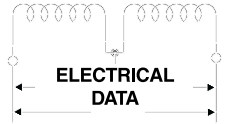

- LEGEND**
- AS - ALTERNATOR STATOR
 - CB2 - CIRCUIT BREAKER; 120V 15A
 - CB4 - CIRCUIT BREAKER; 120V 15A
 - CB5 - CIRCUIT BREAKER; 240V 50A
 - CB6 - CIRCUIT BREAKER; 240V 50A
 - CB7 - CIRCUIT BREAKER; 240V 175A (GR-50)
 - CB8 - CIRCUIT BREAKER; 240V 250A (GR-70)
 - CB8 - CIRCUIT BREAKER; 240V 300A (GR-85)
 - CB8 - CIRCUIT BREAKER; 240V 350A (GR-100)
 - CB8 - CIRCUIT BREAKER; 240V 500A (GR-125)
 - CB8 - CIRCUIT BREAKER; 240V 600A (GR-150)
 - CB8 - CIRCUIT BREAKER; 240V 800A (GR-210)
 - CB8 - CIRCUIT BREAKER; 480V 60A (GR-50)
 - CB8 - CIRCUIT BREAKER; 480V 125A (GR-70)
 - CB8 - CIRCUIT BREAKER; 480V 150A (GR-85)
 - CB8 - CIRCUIT BREAKER; 480V 200A (GR-100)
 - CB8 - CIRCUIT BREAKER; 480V 225A (GR-125)
 - CB8 - CIRCUIT BREAKER; 480V 300A (GR-150)
 - CB8 - CIRCUIT BREAKER; 480V 300A (GR-210)
- CL1 - COMPRESSION LUGS, LOW VOLTAGE
 - CL2 - COMPRESSION LUGS, HIGH VOLTAGE
 - CT1 - CURRENT TRANSFORMER - PHASE 1
 - CT2 - CURRENT TRANSFORMER - PHASE 2
 - CT3 - CURRENT TRANSFORMER - PHASE 3
 - DPE - EXCITATION WINDING
 - EF - EXCITER FIELD
 - GFM - GROUND FAULT CIRCUIT INTERRUPTER MODULE
 - RE1 - RECEPTACLE, 120V 50A LOCKING L5-20R
 - RE3 - RECEPTACLE, 120V 50A GFCI DUPLEX S-20R
 - RE4 - RECEPTACLE, 120/240V 50A LOCKING CS6369
 - SW4 - SWITCH, SAFETY CUTOFF
 - SW7 - SWITCH, SAFETY CUTOFF
 - TP - THERMAL PROTECTION
 - TS - TMD WIRE START TERMINAL STRIP

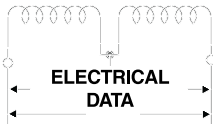

Electrical Data

GR-125 Generator Set

Schematic – AC Receptacle Panel – Drawing No. 0C4690-C

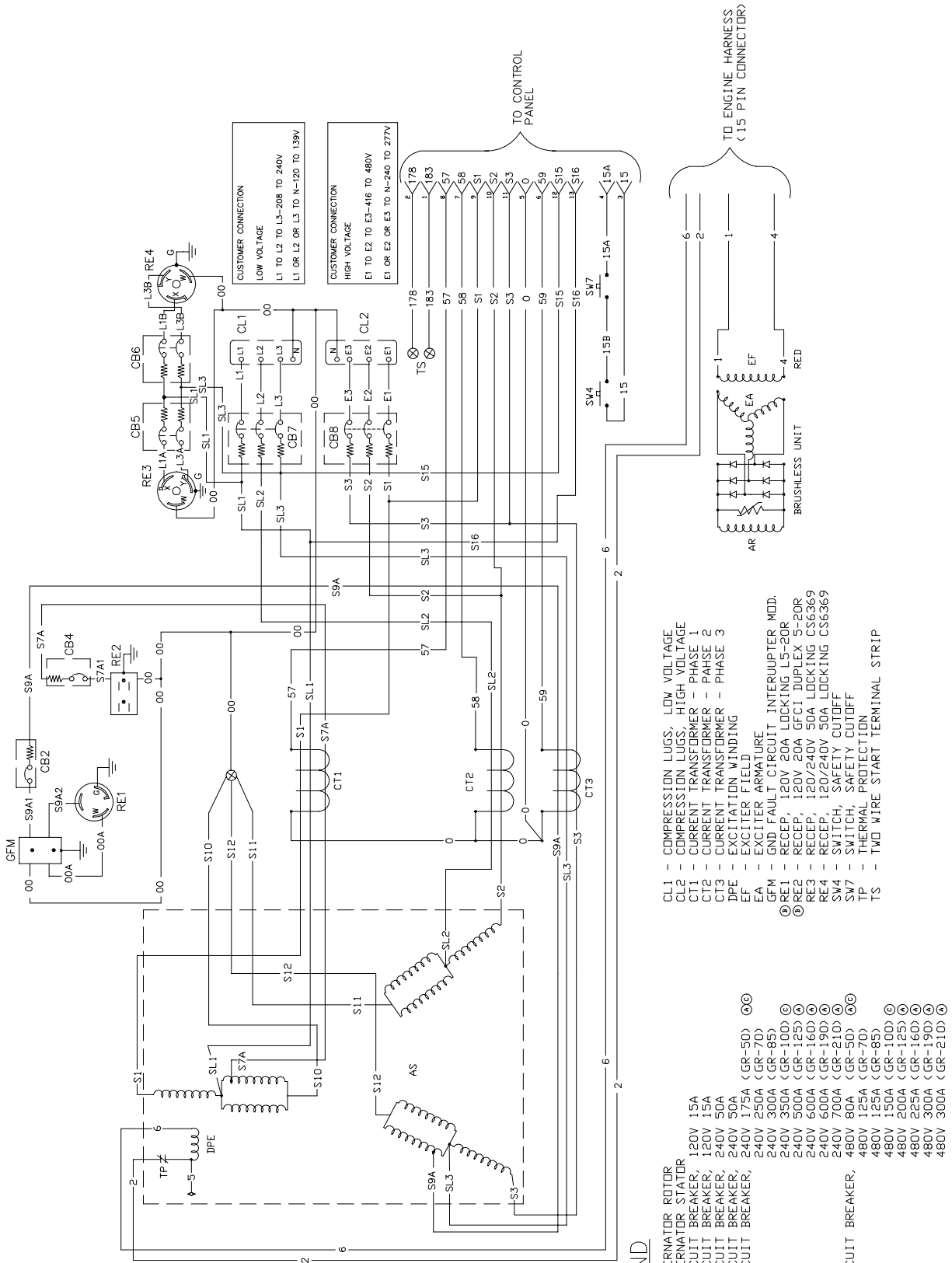

LEGEND

- AR - ALTERNATOR ROTOR
- AS - ALTERNATOR STATOR
- CB2 - CIRCUIT BREAKER, 120V 15A
- CB4 - CIRCUIT BREAKER, 120V 15A
- CB5 - CIRCUIT BREAKER, 240V 50A
- CB6 - CIRCUIT BREAKER, 240V 50A
- CB7 - CIRCUIT BREAKER, 240V 175A (GR-50) ⓄⓄ
- CB8 - CIRCUIT BREAKER, 240V 250A (GR-70) ⓄⓄ
- CB8 - CIRCUIT BREAKER, 240V 300A (GR-85) Ⓞ
- CB8 - CIRCUIT BREAKER, 240V 350A (GR-100) Ⓞ
- CB8 - CIRCUIT BREAKER, 240V 500A (GR-125) Ⓞ
- CB8 - CIRCUIT BREAKER, 240V 600A (GR-150) Ⓞ
- CB8 - CIRCUIT BREAKER, 240V 900A (GR-190) Ⓞ
- CB8 - CIRCUIT BREAKER, 240V 1200A (GR-210) ⓄⓄ
- CB8 - CIRCUIT BREAKER, 480V 60A (GR-50) ⓄⓄ
- CB8 - CIRCUIT BREAKER, 480V 125A (GR-70) Ⓞ
- CB8 - CIRCUIT BREAKER, 480V 150A (GR-85) Ⓞ
- CB8 - CIRCUIT BREAKER, 480V 200A (GR-100) Ⓞ
- CB8 - CIRCUIT BREAKER, 480V 225A (GR-125) Ⓞ
- CB8 - CIRCUIT BREAKER, 480V 300A (GR-160) Ⓞ
- CB8 - CIRCUIT BREAKER, 480V 300A (GR-190) Ⓞ
- CB8 - CIRCUIT BREAKER, 480V 300A (GR-210) Ⓞ

- CL1 - COMPRESSION LUGS, LOW VOLTAGE
- CL2 - COMPRESSION LUGS, HIGH VOLTAGE
- CT1 - CURRENT TRANSFORMER - PHASE 1
- CT2 - CURRENT TRANSFORMER - PHASE 2
- CT3 - CURRENT TRANSFORMER - PHASE 3
- DPE - EXCITATION WINDING
- EA - EXCITER FIELD
- EF - EXCITER ARMATURE
- EM - GND. FAULT CIRCUIT INTERRUPTER MDD.
- RE1 - RECEPT, 120V 20A LOCKING LS-20R
- RE2 - RECEPT, 120V 20A GFCI DUPLEX S-20R
- RE3 - RECEPT, 120V/240V 50A LOCKING CS6369
- RE4 - RECEPT, 120V/240V 50A LOCKING CS6369
- SW4 - SWITCH, SAFETY CUTOFF
- SW7 - SWITCH, SAFETY CUTOFF
- TP - THERMAL PROTECTION
- TS - TWO WIRE START TERMINAL STRIP

Electrical Data

GR-125 Generator Set

Wiring Diagram – Diesel Engine – Drawing No. 0A5356

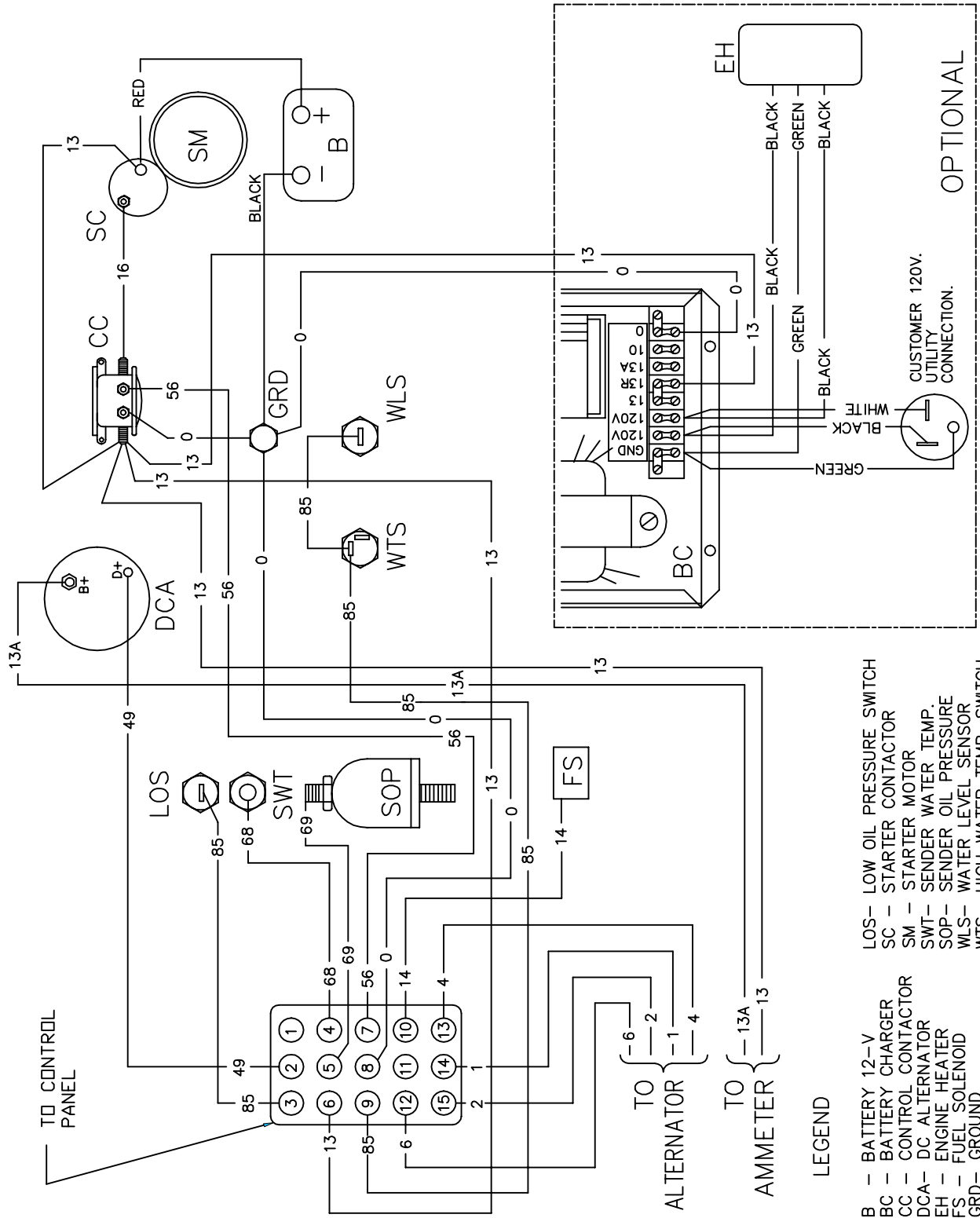
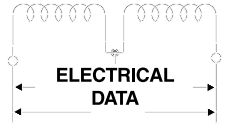

- LEGEND**
- B - BATTERY 12-V
 - BC - BATTERY CHARGER
 - CC - CONTROL CONTACTOR
 - DCA - DC ALTERNATOR
 - EH - ENGINE HEATER
 - FS - FUEL SOLENOID
 - GRD - GROUND
 - LOS - LOW OIL PRESSURE SWITCH
 - SC - STARTER CONTACTOR
 - SM - STARTER MOTOR
 - SWT - SENDER WATER TEMP.
 - SOP - SENDER OIL PRESSURE
 - WLS - WATER LEVEL SENSOR
 - WTS - HIGH WATER TEMP. SWITCH

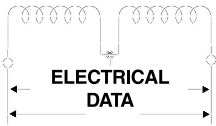

Electrical Data

GR-125 Generator Set

Schematic – Diesel Engine – Drawing No. 0A5357

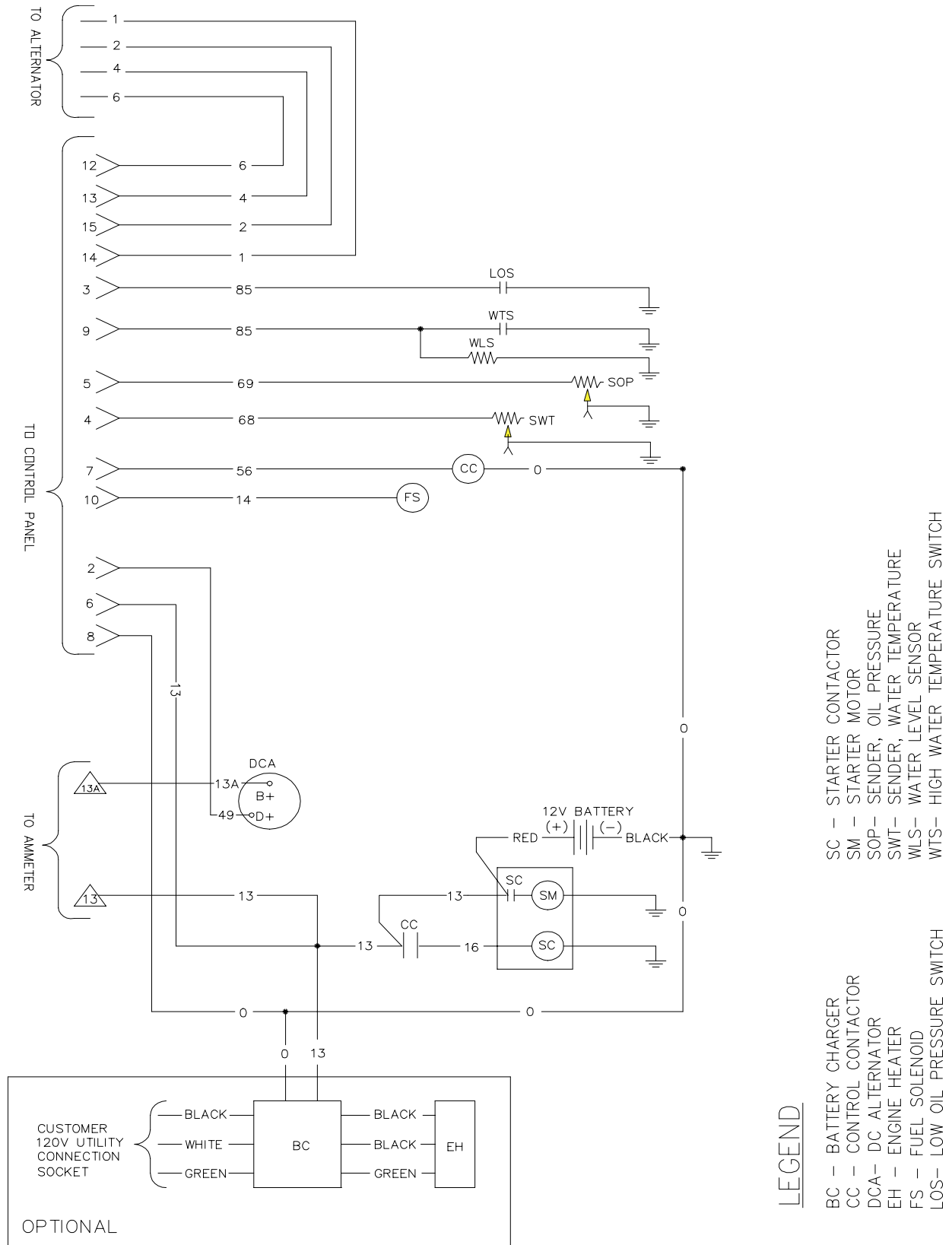

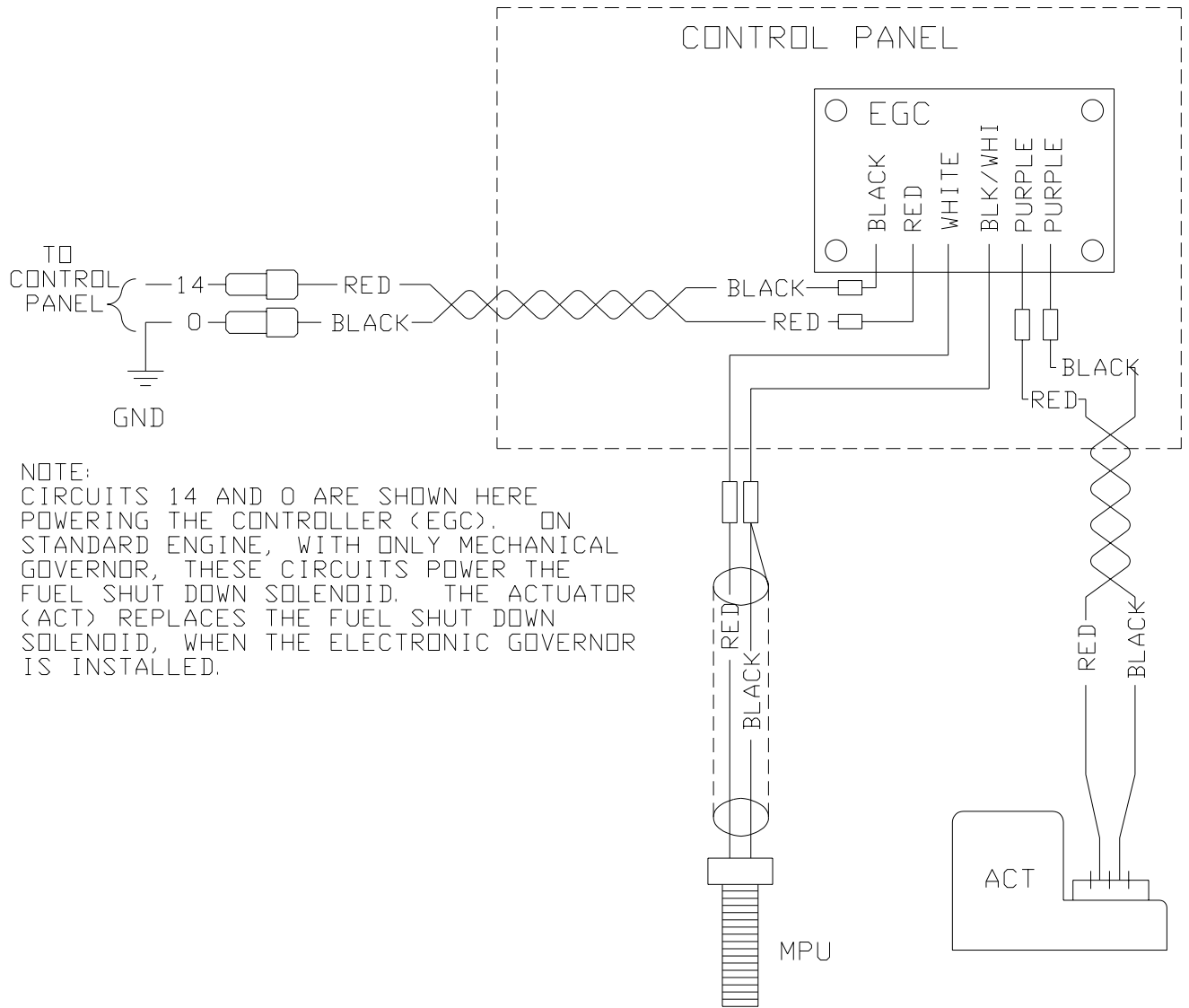
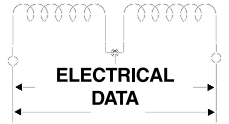

NOTE:
CIRCUITS 14 AND 0 ARE SHOWN HERE
POWERING THE CONTROLLER (EGC). ON
STANDARD ENGINE, WITH ONLY MECHANICAL
GOVERNOR, THESE CIRCUITS POWER THE
FUEL SHUT DOWN SOLENOID. THE ACTUATOR
(ACT) REPLACES THE FUEL SHUT DOWN
SOLENOID, WHEN THE ELECTRONIC GOVERNOR
IS INSTALLED.

LEGEND

- ACT - ACTUATOR
- EGC - ELECTRONIC GOVERNOR CONTROLLER
- MPU - MAGNETIC PICK-UP

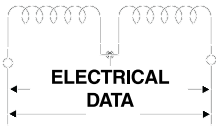

Electrical Data

GR-125 Generator Set

Wiring Diagram — Battery Charger — Drawing No. 0D2672

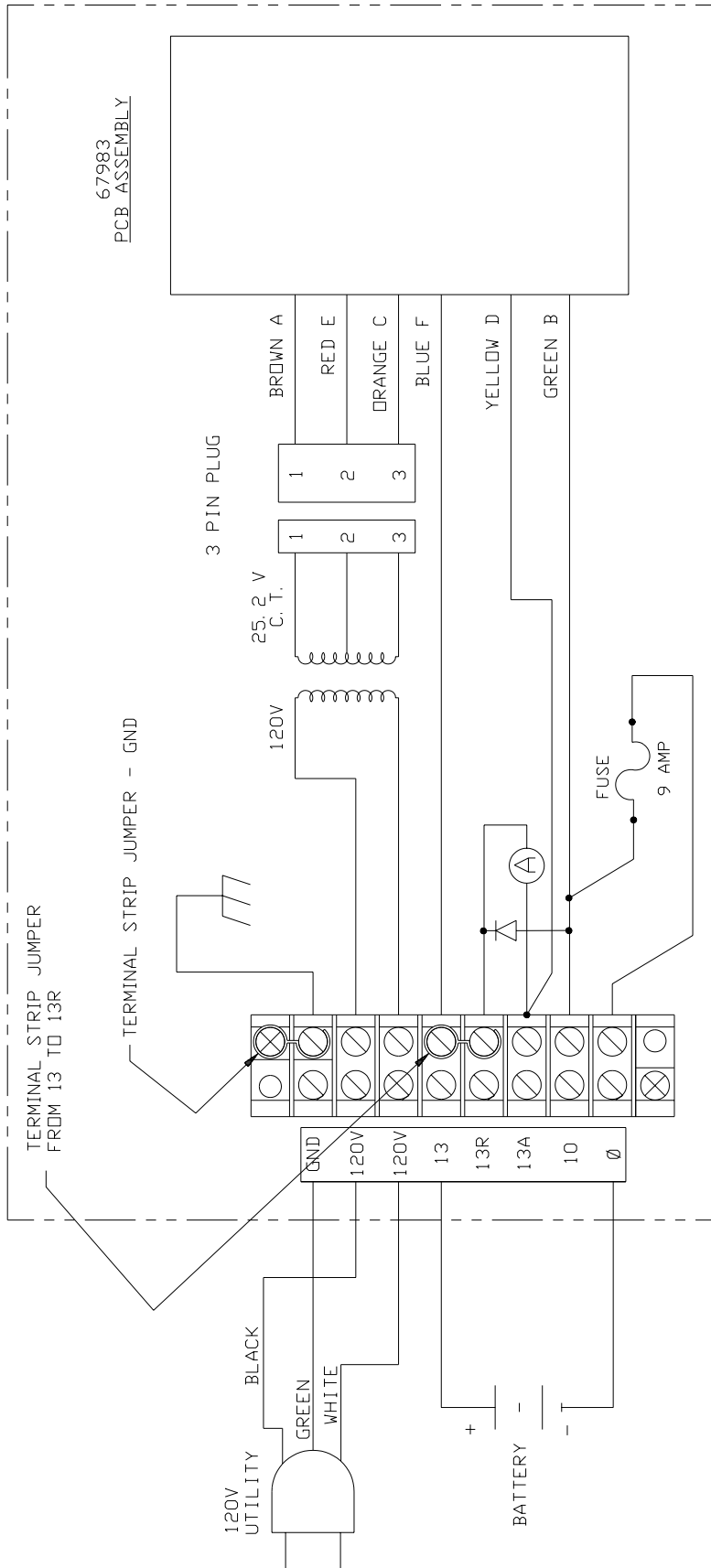

Exploded View and Parts List

GR-125 Generator Set

Electronic Governor – Drawing No. 0D2170-B

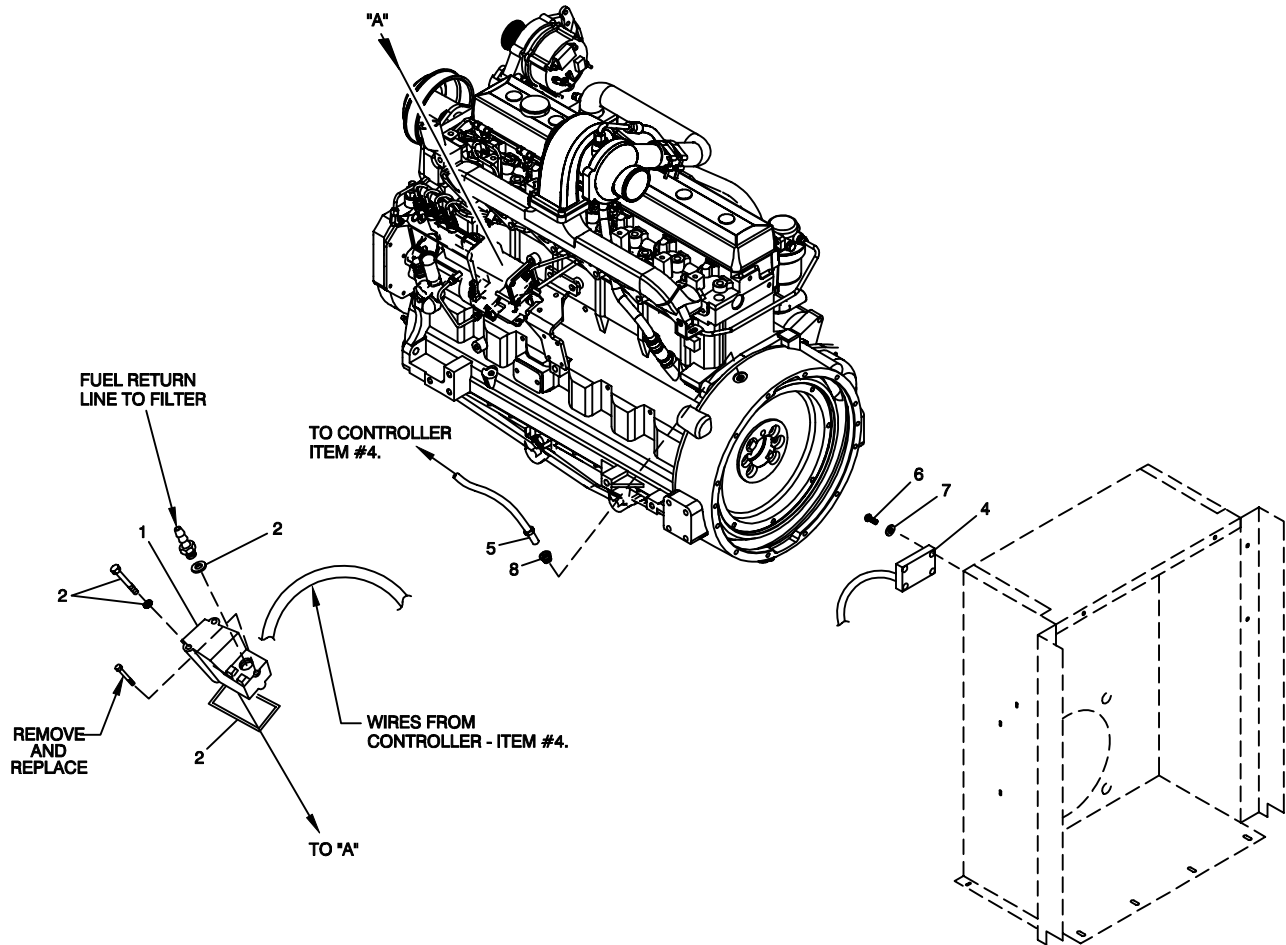
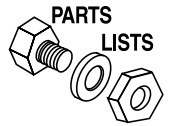

ITEM PART NO. QTY. DESCRIPTION

1	090091	1	ACTUATOR ELECTRONIC GOVERNOR
2	090166	1	KIT, GASKET ELECTRONIC GOVERNOR
"	"	2	SCREW #10-24
"	"	2	LOCKWASHER EXTERNAL TOOTH
"	"	1	COVER SEAL
"	"	1	O-RING
4	090093	1	ASSEMBLY CONTROLLER
5	082130G	1	ASSEMBLY MAGNETIC PICK 48"
6	033138	4	SCREW HHM #10-32 X 5/8
7	023897	4	WASHER FLAT #10 ZINC
8	088034A	1	REDUCER 3/4 TO 3/8



Exploded View and Parts List
GR-125 Generator Set – “If so equipped”
Trailer – Drawing No. 0A5366-C

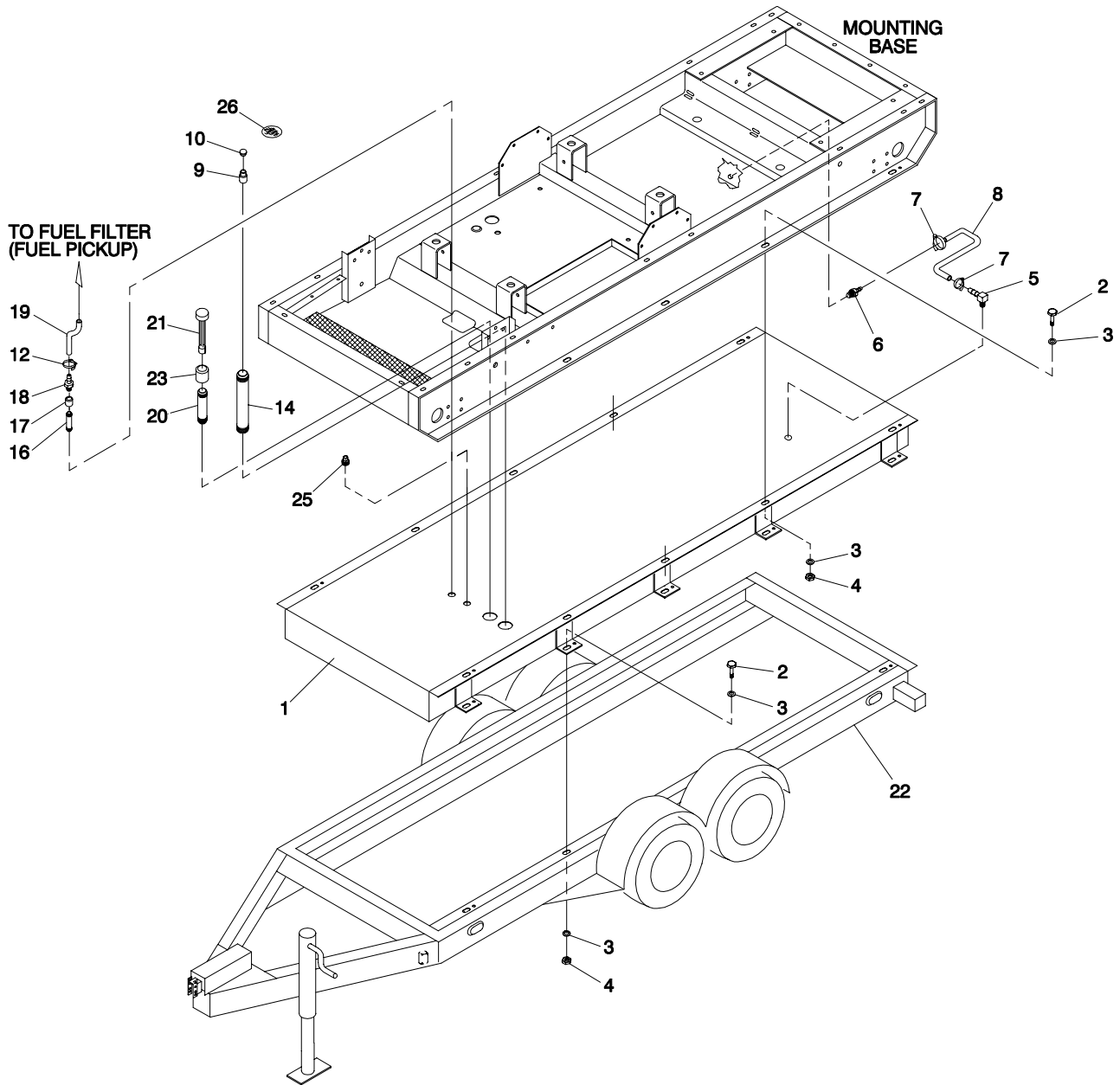

ITEM	PART NO.	QTY.	DESCRIPTION	ITEM	PART NO.	QTY.	DESCRIPTION
1	0A4180	1	FUEL TANK, 6.8L JD TRL	14	091059	1	NIPPLE PIPE 2 NPT X 17
2	035713	20	SCREW HHC 1/2-13 X 1-1/2 G5	16	035482	1	NIPPLE PIPE 1/4 NPT X 6
3	022304	40	WASHER FLAT 1/2 ZINC	17	024268	1	COUPLING FULL 1/4-18
4	073320	20	NUT LOCK HEX INDENT 1/2-13 G5	18	058043	1	BARBED STRAIGHT 1/4 NPT X 5/16
5	056460	1	ELBOW BARBED 90 1/2 NPT X 5/8	19	052221	28"	HOSE RES 5/16 ID TYP1 SNGL HTR
6	044118	1	BARBED STRAIGHT 1/2 NPT X 5/8	20	091042	1	NIPPLE PIPE 1-1/2 NPT X 5.68
7	057823	2	CLAMP HOSE #10 .56 - 1.06	21	090578	1	GAUGE FUEL 15"
8	057448	10.5"	HOSE 5/8 ID TYP 3 SNGL	22	0A5438	1	TRAILER GR-125
9	091058	1	NECK FUEL FILL	23	067729	1	COUPLING FULL 1.5-11.5 TAPERED
10	091057	1	CAP FUEL FILL	25	026925	1	PLUG STD PIPE 3/8 STEEL SQ HD
12	040173	2	CLAMP HOSE #5.5 .62 - .62	26	095198	1	DECAL- FILL SEQUENCE

Exploded View and Parts List
 GR-125 Generator Set
 Center Lift — Drawing No. 0A5355-D

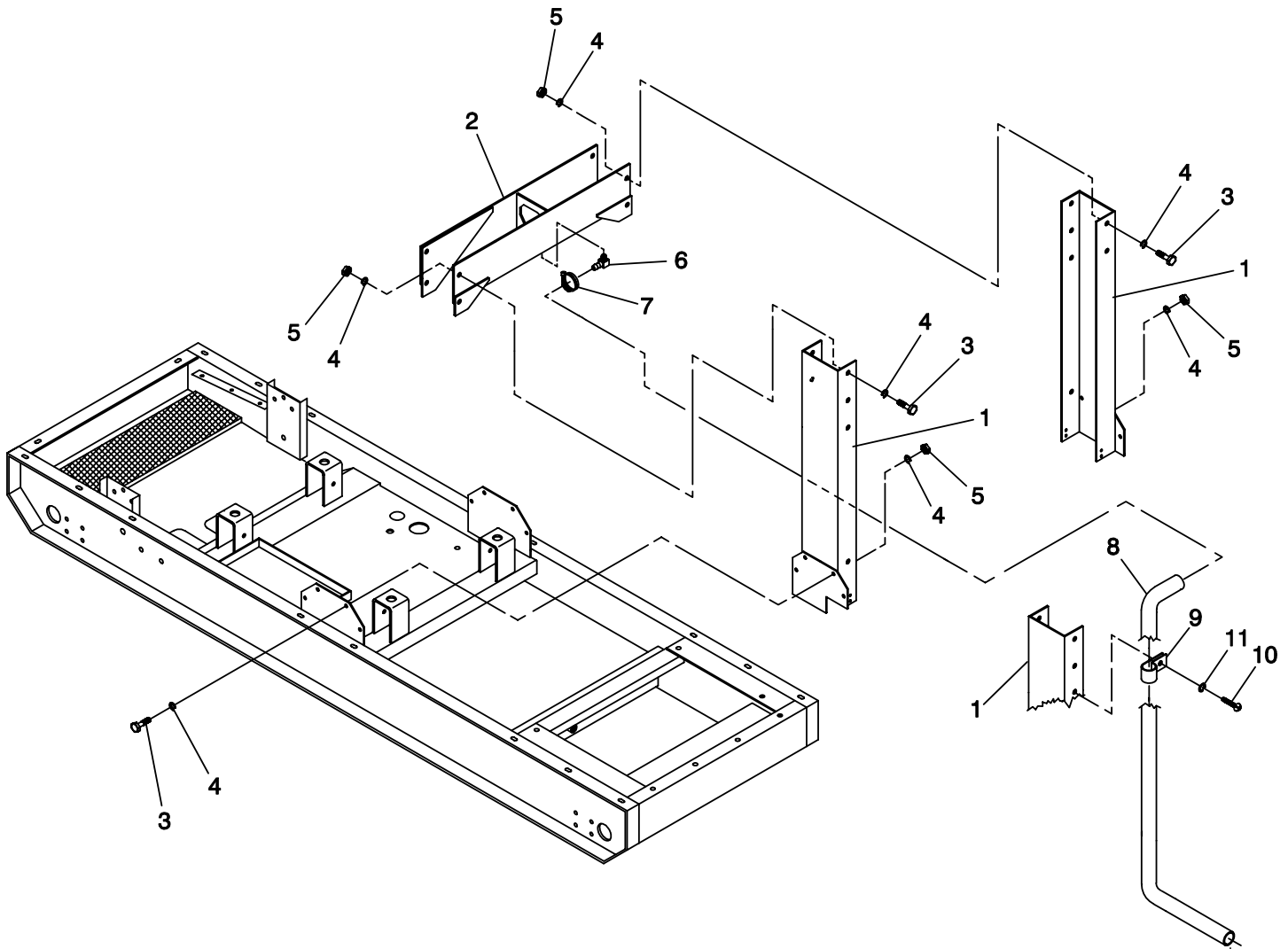
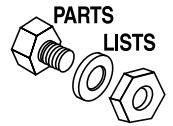

ITEM	PART NO.	QTY.	DESCRIPTION
1	0A4047	2	CENTERLIFT SIDE
2	089483B	1	CENTERLIFT TOP
3	090323	16	SCREW HHC 5/8-11 X 1-1/2 G5
4	022247	32	WASHER FLAT 5/8 ZINC
5	081010	16	NUT LOCK HEX INDENT 5/8-11 G5
6	056460	1	ELBOW BARBED 90 1/2 NPT X 5/8
7	057822	1	CLAMP HOSE #8 .53 - 1.00
8	050967	105"	HOSE 5/8 ID RIA 250F
9	055934B	2	CLAMP VINYL 1 X .281 Z
10	083512	2	SCREW TAPTITE M8-1.25 X 16 BP
11	022129	2	WASHER LOCK M8-5/16

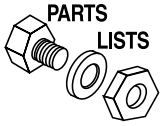

Exploded View and Parts List

GR-125 Generator Set

Mounting Base – Drawing No. 0A5359-F

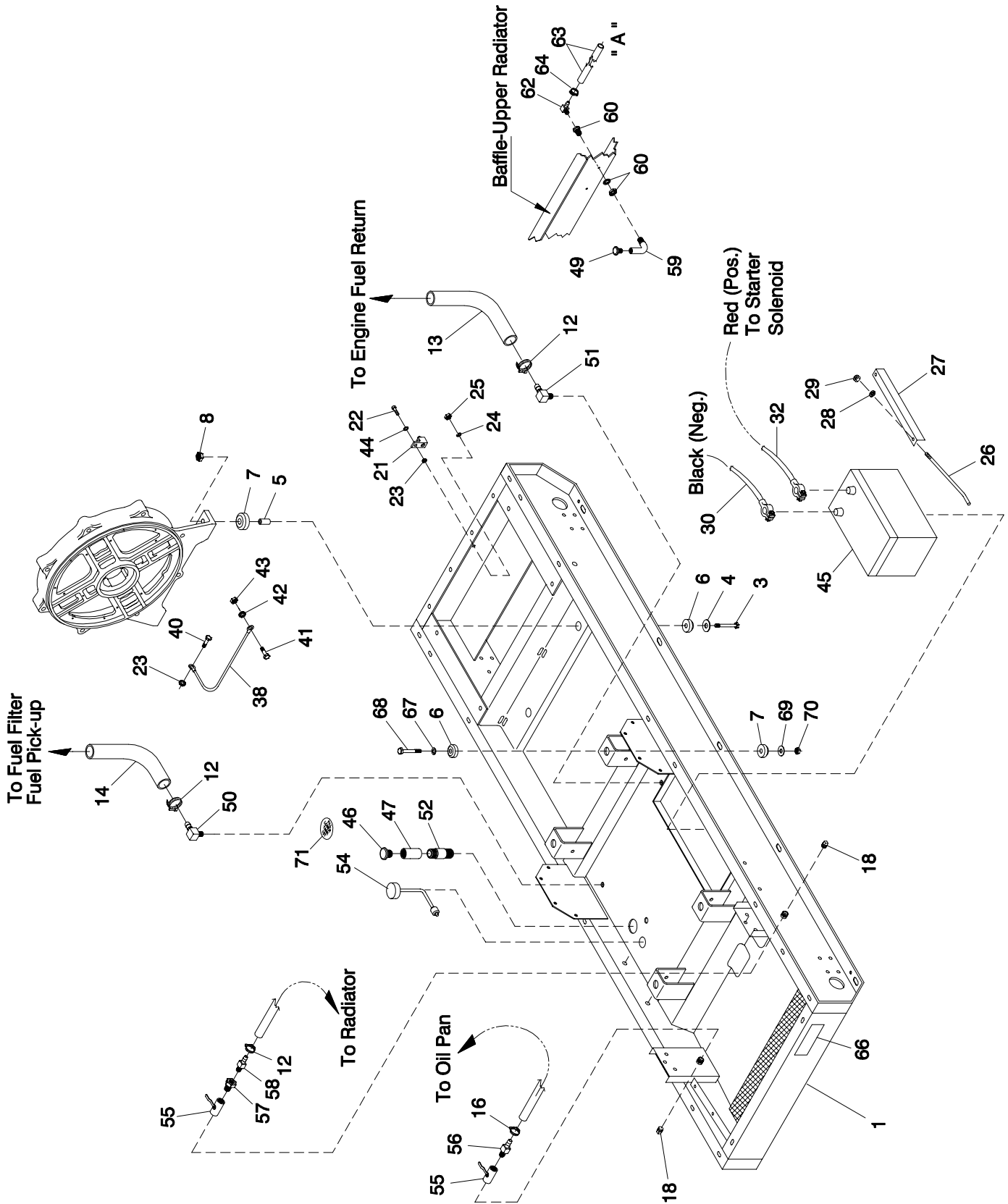

Exploded View and Parts List

GR-125 Generator Set

Mounting Base — Drawing No. 0A5359-F



ITEM	PART NO.	QTY.	DESCRIPTION	ITEM	PART NO.	QTY.	DESCRIPTION
1	0A3967	1	BASE, MOUNTING	42	027482	1	WASHER SHAKEPROOF EXT 5/16 STL
3	055597	2	SCREW HHC M12-1.75 X 85 G8.8	43	022259	1	NUT HEX 5/16-18 STEEL
4	052259	6	WASHER FLAT M12	44	022131	1	WASHER FLAT 3/8-M10 ZINC
5	052257	4	SPACER .49 X .62 X 1.87 PWDR/ZNC	45	061915	1	BATTERY 12V 135-AH 4DLT
6	059675	6	MOUNT UPPER VIBRATION	46	091057	1	CAP FUEL FILL
7	059676	6	MOUNT LOWER VIBRATION	47	091058	1	NECK FUEL FILL
8	052860	2	NUT LOCK M12-1.75	49	026847	1	BREATHER
12	035472	3	CLAMP HOSE #6 .43 - .78	50	059502	1	ELBOW BARBED 90 1/4 NPT X 5/16
13	074995	42"	HOSE 1/4 ID PETROLEUM	51	062007	1	ELBOW BARBED 90 1/4 NPT X 1/4
14	052221	42"	HOSE 5/16 ID TYP1 SNGL HTR	52	090608	1	NIPPLE PIPE 2 NPT X 7 BLK IRON
16	057822	1	CLAMP HOSE #8 .53 - 1.00	54	090321	1	GAUGE FUEL 8"
18	036532	2	CAP PIPE 1/2" NPT	55	078944	2	VALVE BALL
21	057329	1	LUG SLDLSS 350-#6 X 13/32 AL/CU	56	044118	1	BARBED STRAIGHT 1/2 NPT X 5/8
22	059980	1	SCREW HHC M10-1.5 X 25 G10.9	57	030418	1	BUSHING REDUCER 1/2 TO 3/8
23	025507	3	WASHER SHAKEPROOF EXT 7/16 STL	58	055596	1	BARBED STRAIGHT 3/8 NPT X 3/8
24	046526	1	WASHER LOCK M10	59	026924	1	ELBOW 90 DEG STREET 3/8
25	045772	1	NUT HEX M10-1.5 G8 YEL CHR	60	091005	1	BULKHEAD ADAPTOR 3/8 NPT
26	059567	2	BOLT BATTERY HOLD DOWN	62	043790	2	ELBOW BARBED 90 3/8 NPT X 3/8
27	059568	1	BAR BATTERY HOLD DOWN	63	047290	96"	HOSE 3/8 ID SINGLE BRAID
28	022145	14	WASHER FLAT 5/16 ZINC	64	040173	3	CLAMP HOSE #5.5 .62 - .62
29	027028	2	NUT LOCK HEX 5/16-18 NYL INSRT	66	094988	1	DECAL GROUNDING
30	038805Y	1	CABLE BATT BLK #1 X 16.00	67	022132	4	WASHER FLAT 9/16 ZINC
32	03880400AA	1	CABLE BATT RED #1 X 44.00	68	059983	4	SCREW HHC M14-2.0 X 110 G8.8
38	0536210147	1	GROUND WIRE #4 10.0"	69	049869	4	WASHER FLAT M16
40	051756	1	SCREW HHC M10-1.5 X 20 G8.8	70	060079	4	NUT LOCK HEX M14-2.0 NYL INS
41	033212	1	SCREW HHC 5/16-18 X 1-1/4 G5	71	095198	1	DECAL- FILL SEQUENCE

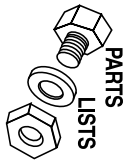

Exploded View and Parts List

GR-125 Generator Set

Compartment — Drawing No. 0A6195-G

○ STATES FOAM IS ON NEAR SIDE
 ○ STATES FOAM IS ON FAR SIDE

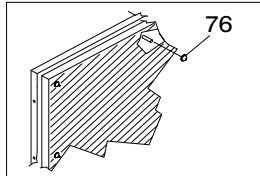

Typical of all duct components & roof panels that require insulation. Secure as shown.

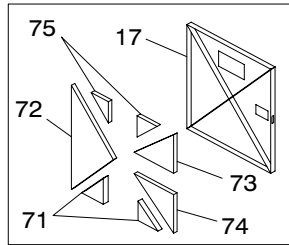

Detail of Rear Door and Insulation

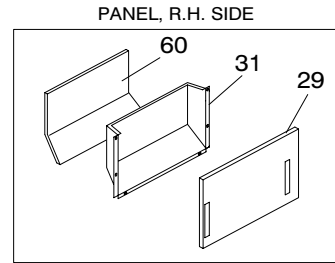

PANEL, R.H. SIDE

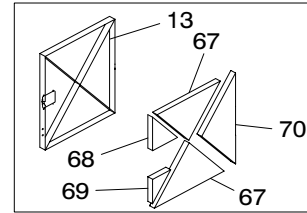

Detail of Side Door and Insulation

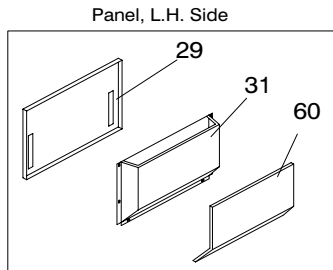

Panel, L.H. Side

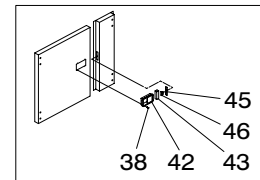
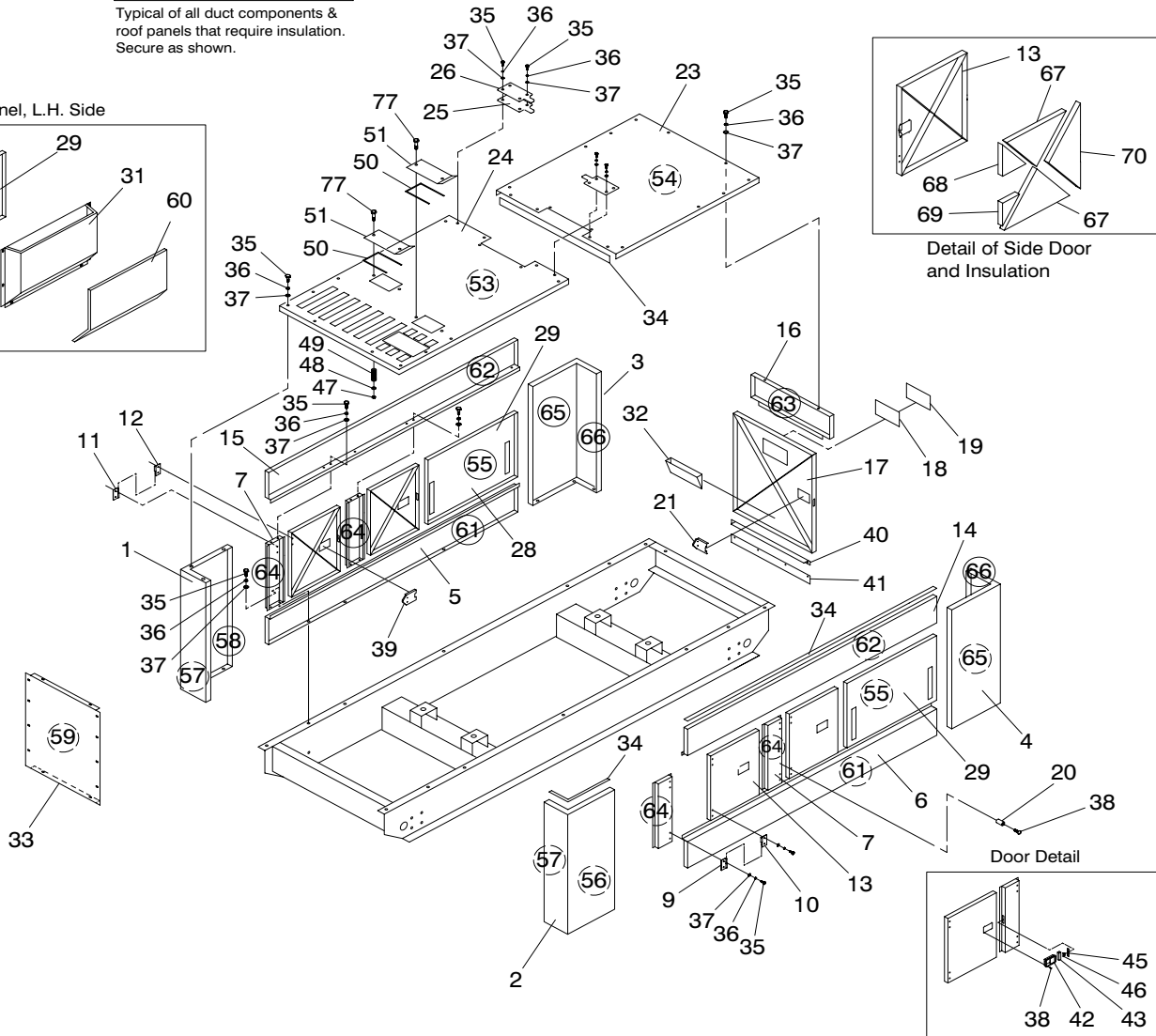

Door Detail

Exploded View and Parts List

GR-125 Generator Set

Compartment — Drawing No. 0A6195-G



ITEM	PART NO.	QTY.	DESCRIPTION	ITEM	PART NO.	QTY.	DESCRIPTION
1	0A4131	1	CORNER POST RH FRONT	42	089900	5	LATCH PADDLE
2	0A4131A	1	CORNER POST LH FRONT	43	089903	5	LOCK ROTARY
3	0A4132	1	CORNER POST RH REAR	45	089488	5	PLATE LATCH PIN
4	0A4132A	1	CORNER POST LH REAR	46	089973	5	PIN STRIKER
5	0A4135B	1	BRACE RH LOWER SIDE	47	052858	2	NUT LOCK FLANGE M8-1.25
6	0A4135A	1	BRACE LH LOWER SIDE	48	022145	2	WASHER FLAT 5/16 ZINC
7	0A4129	4	POST SIDE COMPT 6.8L	49	056315	2	SPRING COMP .35 ID X 1.0
9	091089A	6	HINGE MALE RH	50	056326	3'	TRIM VINYL BLACK 1/8 GP
10	091090A	6	HINGE FEMALE RH	51	056313	2	COVER ACCESS
11	091087A	4	HINGE MALE LH	52	0A7062	1	INSL KT 6.8L EAGLE (NOT SHOWN)
12	091088A	4	HINGE FEMALE LH	53	0A7062L	1	(AI) ROOF FRONT
13	092141	4	DOOR-FRONT	54	0A7062M	1	(AI) ROOFREAR
14	0A4134	1	BRACE UPPER SIDE LH	55	0A7062A	2	(AI) BAFFLE REAR SIDE
15	0A4134A	1	BRACE UPPER SIDE RH	56	0A7062Y	1	(AI) CORNER POST LH FRONT
16	0A4128	1	CROSS PANEL REAR TOP	57	0A706200AA	2	(AI) CORNER POST LH FRONT
17	091111	1	DOOR RECEPTACLE PANEL	58	0A7062Z	1	(AI) CORNER POST RH FRONT
18	079498	1	WINDOW RECEPTACLE PANEL REAR	59	0A7062B	1	(AI) PANEL FRONT
19	079497	2'	WEATHERSTRIP .625 WIDTH	60	0A7062C	2	(AI) BAFFLE REAR SIDE
20	091006	4	BUMPER RUBBER	61	0A7062E	2	(AI) BRACE LOWER SIDE
21	089461	1	COVER LATCH	62	0A7062F	2	(AI) BRACE UPPER SIDE
23	0A4126	1	ROOF REAR PANEL	63	0A7062G	1	(AI) PANEL CROSS TOP
24	0A4125	1	ROOF FRONT PANEL	64	0A7062H	4	(AI) POST SIDE
25	0A3339	2	SEAL ROOF NEOPRENE RF GR	65	0A7062J	2	(AI) CORNER POST REAR
26	0A3340	2	SEAL ROOF GR	66	0A7062K	2	(AI) CORNER POST REAR
28	0A4133	2	BAFFLE REAR SIDE PANEL	67	0A7062N	8	(AI) DOOR COMP SIDE
29	0A4130	2	PANEL REAR SIDE	68	0A7062P	4	(AI) DOOR COMP SIDE
31	0A4133	2	BAFFLE,REAR SIDE PNL	69	0A7062Q	4	(AI) DOOR COMP SIDE
32	091112	1	HOLDER MANUAL	70	0A7062X	4	(AI) DOOR COMP SIDE
33	0A4127	1	PANEL FRONT	71	0A7062R	2	(AI) DOOR COMP REAR
34	089961	1	FOAM STRIP 3/4 X 1/4" (44.5")	72	0A7062T	1	(AI) DOOR COMP REAR
35	070013	127	SCREW HHC 5/16-18 X 3/4 SS VIB	73	0A7062U	1	(AI) DOOR COMP REAR
36	070006	167	WASHER LOCK M8 SSTL	74	0A7062V	1	(AI) DOOR COMP REAR
37	095395	75	WASHER NYLON .315	75	0A7062W	2	(AI) DOOR COMP REAR
38	078436	23	SCREW PPHM #8-32 X 1/2 SS	76	078115	8	WASHER SELF LOC/DOME
39	089357	5	COVER LATCH	77	042909	2	SCREW HHC M8-1.25 X 30 G8.8
40	090355	1	BRACKET SPLASH GUARD				
41	090354	1	GUARD SPLASH				

NOTE: P/N 0A7062 KIT INSULATION 6.8L, PARTS ARE NOTED WITH (AI).

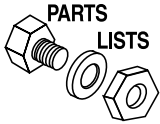

Exploded View and Parts List

GR-125 Generator Set

Connection Panel — Drawing No. 0A5165-F

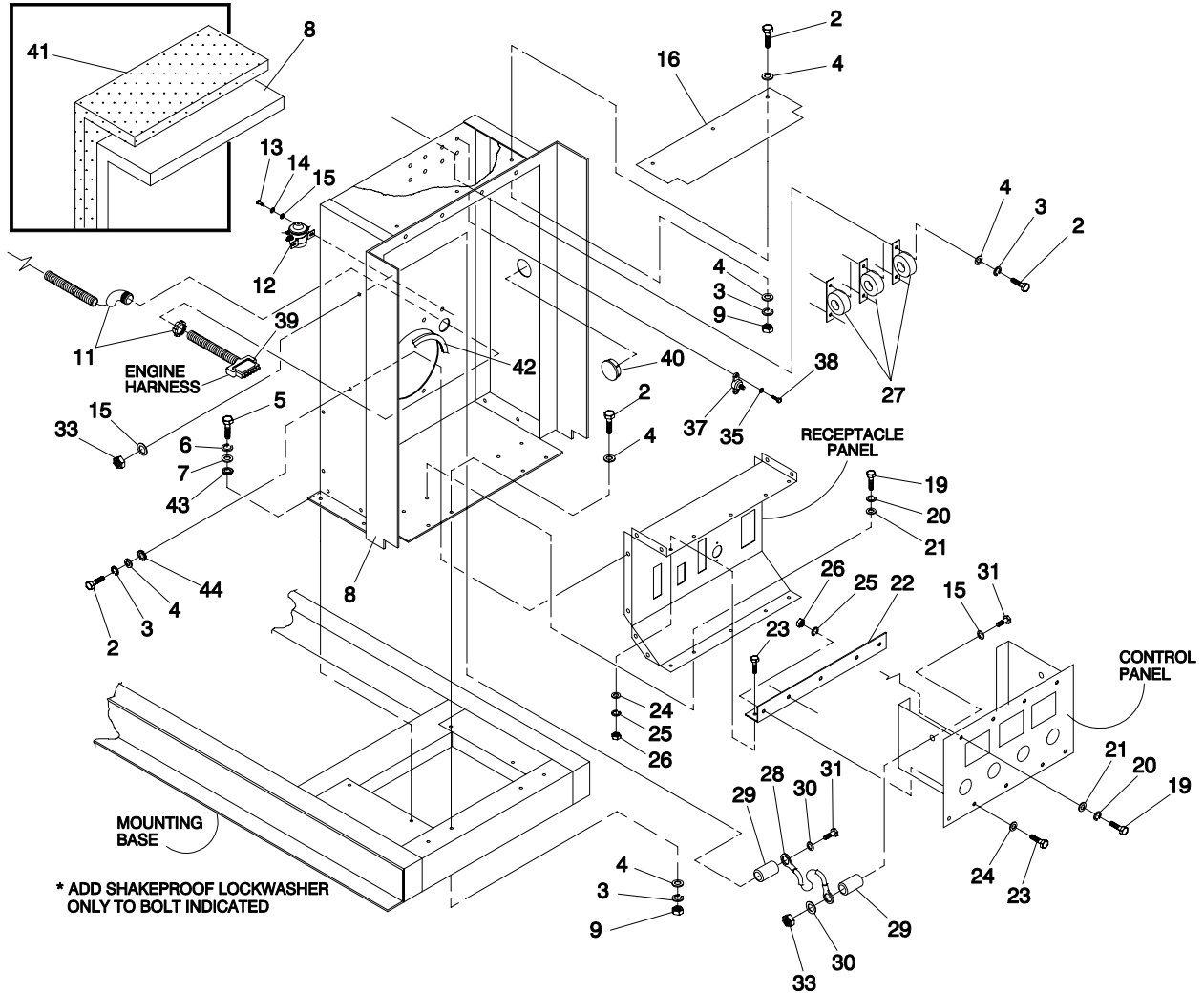

ITEM	PART NO.	QTY.	DESCRIPTION	ITEM	PART NO.	QTY.	DESCRIPTION
2	070013	23	SCREW HHC 5/16-18 X 3/4 SS VIB	24	090427	10	WASHER FLAT #10 SS
3	070006	23	WASHER LOCK M8 SSTL	25	040295	10	WASHER LOCK #10 SS
4	090977	32	WASHER FLAT .375 ID X .875 OD	26	040292	10	NUT HEX #10-32 SSTL
5	029745	4	SCREW HHC 3/8-16 X 1 G5	27	059925	3	TRANSFORMER 600A TO 5A
6	022237	4	WASHER LOCK 3/8	28	090515	1	CABLE CONTROL PANEL
7	022131	4	WASHER FLAT 3/8-M10 ZINC	29	038196	2	SPACER .28 X .62 X .19 STL/ZNC
8	0A3864	1	ASSEMBLY CONTROL BOX PANEL 6.8L JD	30	054381	2	WASHER FLAT .266 ID X 1.0 OD
9	082351	9	NUT HEX 5/16-18 SSTL	31	022287	2	SCREW HHC 1/4-20 X 3/4 G5
11	034616	1	FITTING STRAIGHT 3/4	33	050993	2	NUT LOCK HEX INDENT 1/4-20
12	056739	1	RELAY SOLENOID 12VDC PANEL MOUNT	35	023897	2	WASHER FLAT #10 ZINC
13	022507	2	SCREW HHC 1/4-20 X 1/2 G5	37	057073	1	JUNCTION BLOCK 3/8-16
14	022097	2	WASHER LOCK M6-1/4	38	033530	2	SCREW PHM #10-32 X 5/8 CAD
15	022473	4	WASHER FLAT 1/4 ZINC	39	055089	1	CONN ELEC AMP M-N-L 15 PLUG PNL
16	090425	1	BAFFLE UPPER RECEPTACLE PANEL	40	058221	1	PLUG PLASTIC 1.750 BLACK
19	085296	10	SCREW HHC 1/4-20 X 1/2 SS	41	0A7567D	1	AI-PANEL CONTROL BOX
20	083896	10	WASHER LOCK 1/4-M6 SS	42	056326	13"	TRIM VINYL BLACK 1/8GP
21	084929	10	WASHER FLAT 1/4 SS	43	022261	1	WASHER SHAKEPROOF INT 3/8
22	089487	1	HINGE CONTROL PANEL	44	026204	1	WASHER SHAKEPROOF INT 5/16
23	090426	10	SCREW PPHM #10-32 X 3/8 SS				

Exploded View and Parts List

GR-125 Generator Set

Receptacle Panel – Drawing No. 0A5145-D



LOOSE WIRES, REFER TO WIRING DIAGRAM 0A5347 FOR PLACEMENT

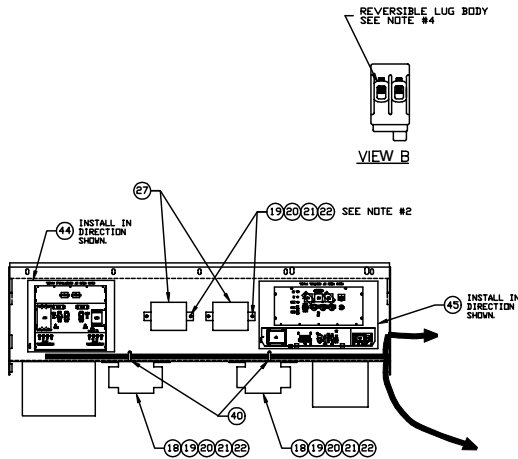

LOOSE WIRES #0A7009W							
WIRE NO.	WIRE SIZE	WIRE P/N	LENGTH	LUG 'A'	LUG 'B'	FROM	TO
00	2	048477	23.00	097174	097174	N	N
	2	048477	23.00				
00	2	048477	41.25	097174	097174	N	NEUTRAL BLOCK
	2	048477	41.25				
00	10	031832	25.00	S/T .62"	028805	RE3	N
00	10	031832	25.00	S/T .62"	028805	RE4	N
SL3	10	031832	14.00	STRIP .62"	STRIP .62"	CB6	CB5
SL1	10	031832	14.00	STRIP .62"	STRIP .62"	CB6	CB5
SL1	6	048261	16.50	STRIP .62"	065672	CB6	CB7
SL3	6	048261	8.75	STRIP .62"	065672	CB6	CB7
L1	1	045909	4.50	097175	STRIP 1.0"	L1	CB7
L1	1	045909	4.50	097175	STRIP 1.0"	L1	CB7
L2	1	045909	4.50	097175	STRIP 1.0"	L2	CB7
L2	1	045909	4.50	097175	STRIP 1.0"	L2	CB7
L3	1	045909	4.50	097175	STRIP 1.0"	L3	CB7
L3	1	045909	4.50	097175	STRIP 1.0"	L3	CB7
E1	2	048477	5.50	097174	STRIP .75"	E1	CB8
E2	2	048477	5.50	097174	STRIP .75"	E2	CB8
E3	2	048477	5.50	097174	STRIP .75"	E3	CB8
L3B	10	031832	10.00	S/T .62"	STRIP .62"	RE4	CB6
L1B	10	031832	10.00	S/T .62"	STRIP .62"	RE4	CB6
L1A	10	031832	10.00	S/T .62"	STRIP .62"	RE3	CB5
L3A	10	031832	10.00	S/T .62"	STRIP .62"	RE3	CB5

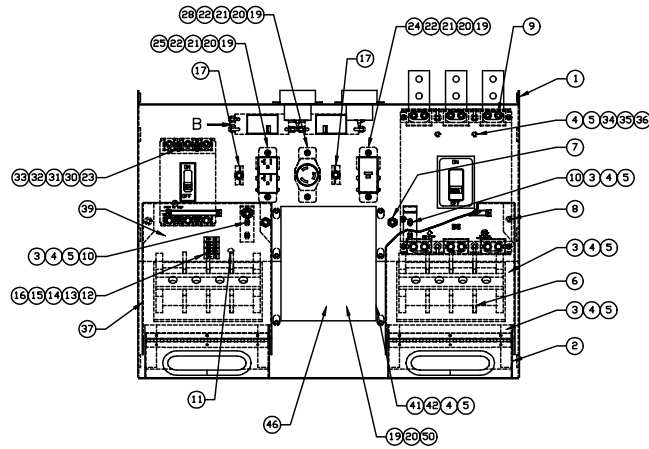
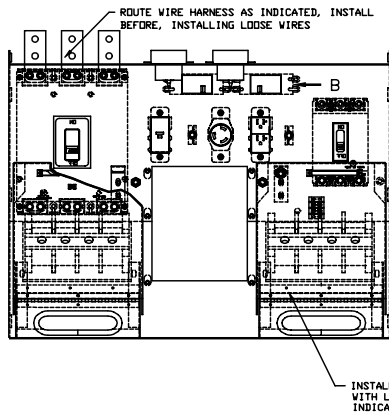

ITEM	PART NO.	QTY.	DESCRIPTION
1	0A5679	1	RECEPTACLE PANEL W/SILKSCREEN (GR-125)
2	0A6791	1	ASSEMBLY LUG BOX LOW VOLTAGE
3	085296	16	SCREW HHC 1/4-20 X 1/2 SS
4	083896	18	WASHER LOCK 1/4-M6 SS
5	084929	24	WASHER FLAT 1/4 SS
6	0A5572	2	ASSEMBLY LUG BLOCK
7	055920	2	SWITCH SPST SPADE PNL MNT
8	080765	2	BUMPER RUBBER
9	065511	12	PLUG BUTTON 1/2"
10	0A2081	2	HASP LUG BOX DOOR
11	022717A	1	GROMMET 3/8 X 1/16 X 1/4
12	048766	1	BLOCK TERM 20A 2 X 6 X 1100V
13	081799	2	WASHER FLAT #6 SS
14	081797	2	WASHER LOCK #6 SS
15	083901	2	SCREW PPHM #6-32 X 1 SS
16	081798	2	NUT HEX #6-32 SSTL
17	075207D	2	CIRCT BRK 15 X 2 UL/CSA
18	083331	2	CIRCT BRK 50 X 2 240V SQUARE D
19	078436	13	SCREW PPHM #8-32 X 1/2 SS
20	078437	13	WASHER LOCK #8-M4 SS
21	078438	14	NUT HEX #8-32 SSTL
22	080490	40	WASHER FLAT #8 SS
23	040295	4	WASHER LOCK #10 SS

ITEM	PART NO.	QTY.	DESCRIPTION
24	080410	1	RECEPTACLE BLANK FACE GFCI 20AMP.
25	080409	1	RECEPTACLE DUPLEX GFCI 20AMP.
27	079486	2	OUTLET 120/240V
28	074190	1	OUTLET 20A 125V NEMA L5-20R
30	090427	8	WASHER FLAT #10 SS
31	040292	4	NUT HEX #10-32 SSTL
32	085294	4	SCREW RHM #10-32 X 4 SS
33	081523U	1	CIRCUIT BREAKER 200 X 3 600V UL SQ D
34	085889	4	NUT HEX 1/4-20 SSTL
35	085295	4	SCREW HHC 1/4-20 X 5 SS
36	081529U	1	CIRCUIT BREAKER 500 X 3 600V UL SQ D
37	0A6792	1	ASSEMBLY LUG BOX HIGH VOLT
38	090441	1	HARNESS RECEPTACLE PANEL (NOT SHOWN)
39	064828	1	DECAL TRANSFER SWITCH CONN
40	029333	1	TIE WRAP 7" WHITE
41	096801	1	GUARD BRIDGE RECTIFIER
42	083895	6	SCREW HHC 1/4-20 X 1 SS
44	091150	1	DECAL RECEPTACLE PANEL
45	091149	1	DECAL CONTROL PANEL
46	094660	4	NUT #10-32 SS (SPECIAL)
50	091175	1	ASSEMBLY WRENCH HEX 3/8

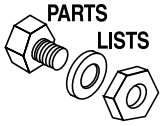

Exploded View and Parts List

GR-125 Generator Set

Control Panel – Drawing No. 0A5164-C

LOOSE WIRES #90126W					
WIRE NO.	WIRE SIZE	WIRE P/N	LENGTH	LUG A	LUG B
29	18	55199A	5.50	STRIP .5'	58355

BOARD TO BE ORIENTED SUCH THAT THE 15 PIN HEADER IS POSITIONED AS SHOWN

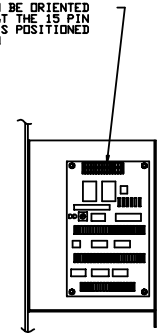

SECTION A-A

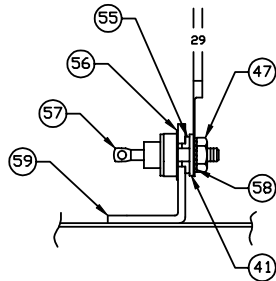

VIEW A

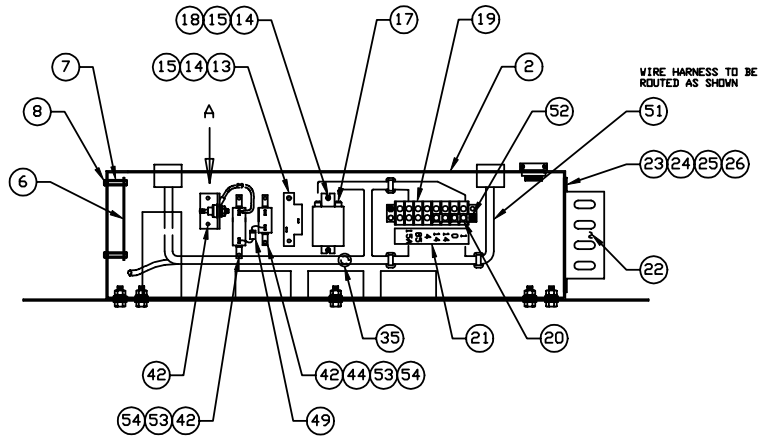

WIRE HARNESS TO BE ROUTED AS SHOWN

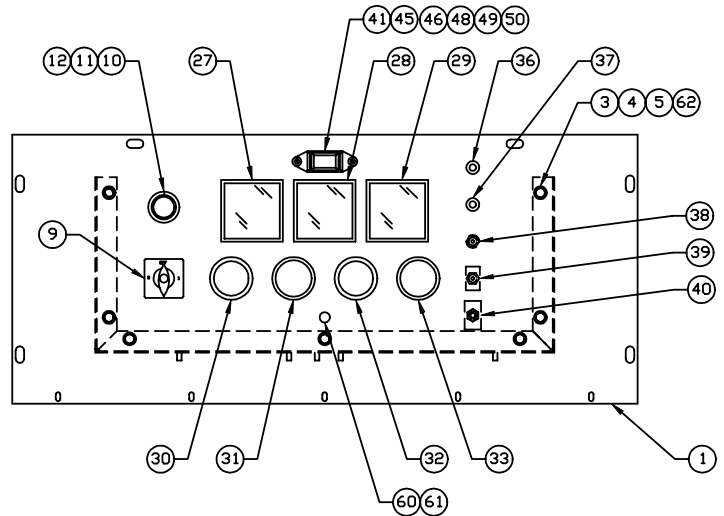
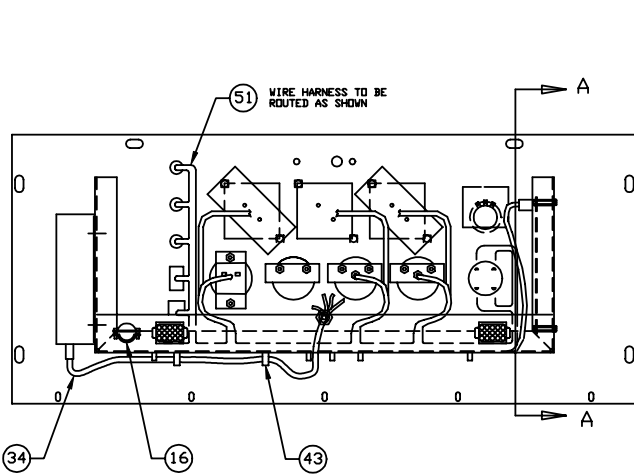

Exploded View and Parts List

GR-125 Generator Set

Control Panel — Drawing No. 0A5164-C

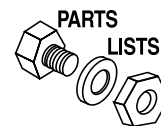

ITEM	PART NO.	QTY.	DESCRIPTION	ITEM	PART NO.	QTY.	DESCRIPTION
1	089532	1	CONTROL PANEL FRONT W/SILKSCREEN	33	070081	1	HOURMETER
2	090504	1	CONTROL PANEL REAR	34	090512	1	HARNESS VOLTAGE REGULATOR
3	085296	7	SCREW HHC 1/4-20 X 1/2 SS	35	042632	1	GROMMET 1/2 X 1/16 X 3/8
4	083896	11	WASHER LOCK 1/4-M6 SS	36	064009B	1	LIGHT 12VDC .02A LED GREEN PILOT
5	084929	18	WASHER FLAT 1/4 SS	37	064009	1	LIGHT 12VDC .02A LED RED PILOT
6	082495	1	ASSEMBLY 12/24V ENGINE CONTROL	38	055920	1	SWITCH SPST SPADE PANEL MOUNT
7	064525	4	STANDOFF HEX 3/4	39	061694	1	SWITCH TOG SPDT 6A SPD CTR OFF
8	064526	8	SCREW TAP HWH #6-25 X 3/8 ZINC	40	061943	1	SWITCH TOG DPST 15A SPD PROG
9	061945	1	SWITCH 6A AMP/V SELECTOR	41	023897	3	WASHER FLAT #10 ZINC
10	055349	1	INSULATOR	42	036261	6	RIVET POP .125 X .129-.133/#30
11	053693	1	POTENTIOMETER 10K 10% 2.25W PANEL MT	43	028739	3	TIE WRAP 4" BLACK
12	050123	1	KNOB PLASTIC .25 SHAFT	44	044213	1	RESISTOR 10R 5% 12W
13	048476	1	CIRCUIT BREAKER 4.5 X 1 AUT30KW CNT45K	45	022152	2	WASHER LOCK #10
14	0C2428	4	SCREW TAPTITE PH #6-32 X 1/2 Z/YC	46	033138	2	SCREW HHM #10-32 X 5/8
15	022155	4	WASHER LOCK #6	47	022158	1	NUT HEX #10-32 STEEL
16	022206	1	FITTING STRAIGHT 3/8	48	070202	1	LIGHT PANEL #26306C
17	063617	1	RELAY PNL 12VDC DPDT 10A@240VA	49	025192	1	RECTIFIER MSC 2A 600V 1N5062
18	022985	2	WASHER FLAT #6 ZINC	50	070082	1	BLOCKER LIGHT
19	057701	1	BLOCK TERM 20A 8 X 6 X 1100V	51	090440	1	HARNESS CONTROL PANEL
20	046669	3	BLOCK TERM JUMPER FOR S141	52	0A1661	2	RIVET POP .156 X .160-.164/#20
21	090513	1	DECAL TERMINAL STRIP	53	057405	1	RESISTOR 25R 5% 25W
22	067680	1	ASSEMBLY VOLTAGE REGULATOR 60HZ	54	064733	2	BRACKET RESISTOR MOUNTING FOR 25W
23	033135	4	SCREW HHM #8-32 X 1/2	55	030468	1	WASHER STEP NYLON .20
24	022264	4	WASHER LOCK M4	56	070370	1	WASHER MICA .203
25	038150	4	WASHER FLAT #8 ZINC	57	049939	1	RECTIFIER MSC 12A 600V 1N1206R
26	022471	4	NUT HEX #8-32 STEEL	58	023762	1	WASHER SHAKEPROOF EXT #10 STEEL
27	079983	1	VOLTMETER DUAL	59	055444	1	HEATSINK
28	070058	1	AMMETER AC 0-400	60	032300	1	HOLDER FUSE
29	070042	1	METER FREQUENCY 55-65HZ	61	022676	1	FUSE 15A X AGC15
30	055406	1	GAUGE COOLANT TEMPERATURE	62	085889	7	NUT HEX 1/4-20 SSTL
31	055405	1	GAUGE OIL PRESSURE				
32	062304	1	AMMETER 40-0-40 DC				

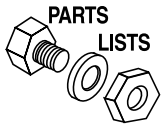

Exploded View and Parts List

GR-125 Generator Set

Generator Assembly — Drawing No. 0A5139-D

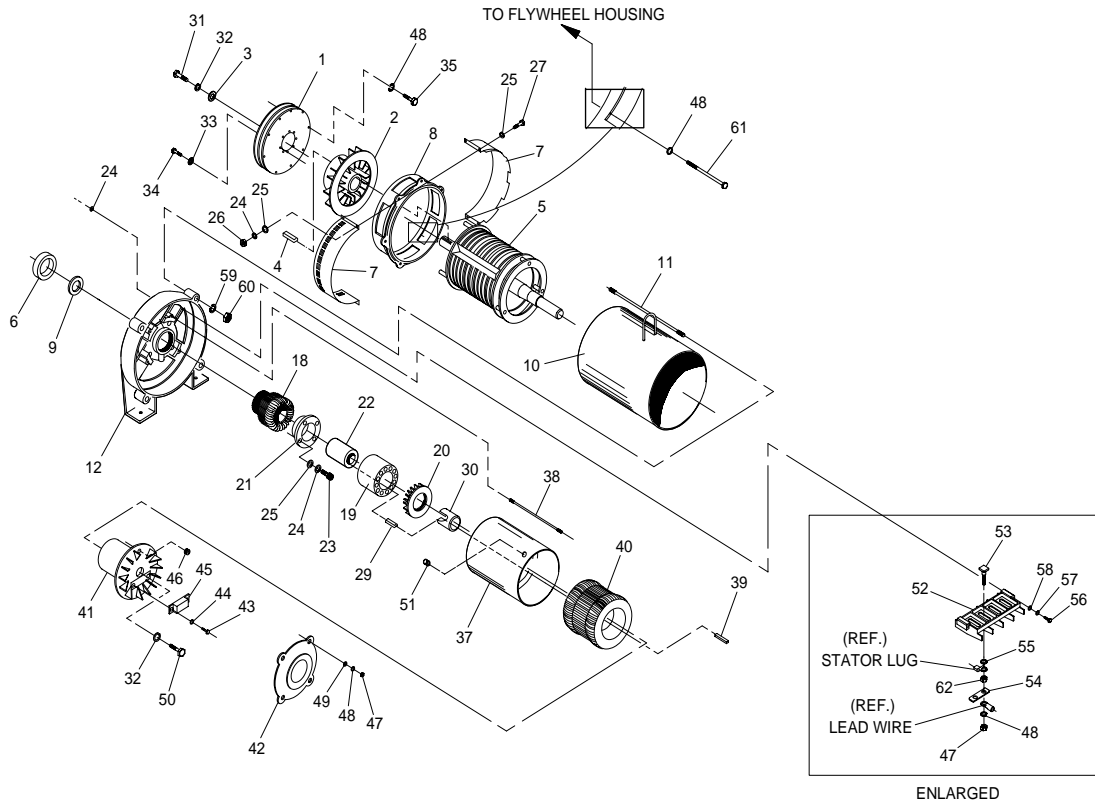

ITEM	PART NO.	QTY.	DESCRIPTION	ITEM	PART NO.	QTY.	DESCRIPTION
1	081803	5	FLEX PLATE 520 6.4L	35	059981	8	SCREW HHC M10-1.5 X 30 G10.9
2	081817	1	DRIVE HUB & FAN MCH	37	086377	1	ASSY,EXC FLD2.75"CAN
3	081815	1	SPACER DRIVE HUB & FAN	38	04576100BV	4	STUD M10-1.5 X 355 G5 ZINC
4	081825	1	KEY SQ 16MM X 76MM STEEL	39	085666	1	KEY SQ 3/8 X 3 STEEL
5	086349G	1	ROTOR 520-150KP1	40	086376	1	ASSEMBLY EXCITER 2-3/4"
6	081831	1	BEARING BALL SINGLE ROW	41	090241	1	FAN EXCITER COOLING
7	082465	2	SCREEN BLOWER HOUSING	42	084338	1	COVER EXCITER REAR
8	088296	1	HSG-SAE3 MACH BLOWER	43	033143	2	SCREW HHM #8-32 X 7/8
9	085369	1	SPACER 520 ROTOR BEARING	44	023365	2	WASHER SHAKEPROOF INT #8
10	0A4335	1	STATOR 520-110QP1	45	090152	1	ASSEMBLY BRIDGE RECTIFIER
11	04576100BQ	4	STUD M16-1.5 X 660 G5 ZINC	46	070208	1	GROMMET .87 X .25 X .62
12	0A7671	1	CARRIER REAR BEARING	47	045772	16	NUT HEX M10-1.5 G8 YEL CHR
18	094511	1	STATOR ASSEMBLY PME 520MM	48	046526	36	WASHER LOCK M10
19	084828	1	HOUSING 520 PME MAGNET	49	022131	30	WASHER FLAT M10-3/8 ZINC
20	080933	1	FAN PME COOLING	50	084777	1	SCREW HHC M20-1.5 X 70 G8.8
21	080934	1	RING PME STATOR RETAINING	51	027744	1	GROMMET 3/4 X 5/32 X 5/16
22	082461	1	COLLAR SLIP FIT 116.7	52	092261	3	BOARD SOLID LEAD TERMINAL
23	082460	4	SCREW SHC M6-1.0 X 65 G10.9	53	095152	12	SCREW SHM M10-1.5 X 40.5
24	022097	8	WASHER LOCK M6-1/4	54	095153	6	PLATE JUMPER
25	022473	12	WASHER FLAT 1/4 ZINC	55	095586	12	WASHER FLAT .41 ID X .75 OD
26	022127	4	NUT HEX 1/4-20 STEEL	56	039287	6	SCREW HHC M8-1.25 X 45 G8.8
27	051751	4	SCREW HHC M6-1.0 X 50 G8.8	57	022129	8	WASHER LOCK M8-5/16
29	085199	1	KEY SQ 3/8 X 13/32 STEEL	58	022145	6	WASHER FLAT 5/16 ZINC
30	085665	1	COLLAR SLIP FIT	59	070265	4	WASHER LOCK M16
31	081812	1	SCREW HHC M20-1.5 X 60 G8.8	60	081810	4	NUT HEX M16-1.5 G8 YEL CHR
32	081814	2	WASHER LOCK M20	61	057642	12	SCREW HHC M10-1.5 X 40 G10.9
33	081811	6	SCREW HHC M16-1.5 X 30 G10.9	62	096139	12	NUT HEX JAM M10-1.5
34	049869	6	WASHER FLAT M16				

Exploded View and Parts List
GR-125 Generator Set
Engine 4.5L — Drawing No. 0A5353-D

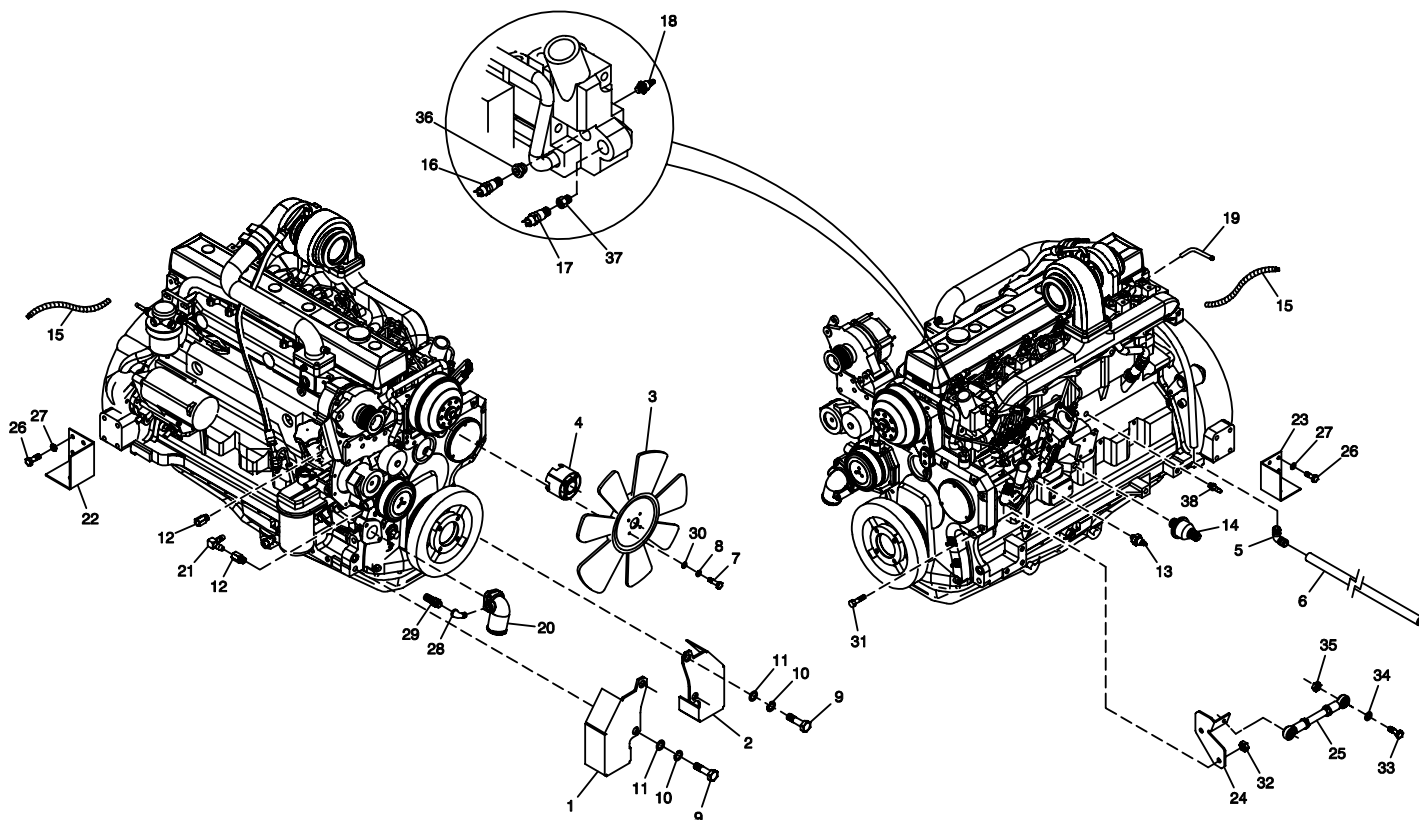
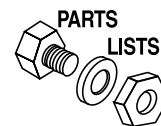

ITEM	PART NO.	QTY.	DESCRIPTION	ITEM	PART NO.	QTY.	DESCRIPTION
1	021551	1	BRACKET LH ENGINE MOUNT	21	034339	1	BARBED ELBOW 90 3/8 NPT X 5/8
2	021542	1	BRACKET RH ENGINE MOUNT	22	0A3931A	1	MOUNT ENGINE REAR RH JD
3	0A5703	1	FAN KYSOR 22"	23	0A3931B	1	MOUNT ENGINE REAR LH JD
4	0A4604	1	SPACER FAN MACHINED 2"	24	0A5676	1	BRACKET INJECTION PUMP JD
5	0A4977	1	BARBED ELBOW 90 3/4-3/4	25	0A5675	1	LINKAGE INJECTION PUMP JD
6	085964	25"	HOSE 3/4 ID 100 R6	26	051768	1	SCREW HHC M12-1.75 X 25 G8.8
7	061906	4	SCREW HHC M8-1.25 X 85 G8.8	27	051769	8	WASHER LOCK M12
8	022129	4	WASHER LOCK M8-5/16	28	026739	1	ELBOW RED STREET 3/4 X 1/2
9	070263	4	SCREW HHC M16-2.0 X 35 G10.9	29	078586	1	BARBED STRAIGHT 3/4 NPT X 1
10	070265	4	WASHER LOCK M16	30	022145	4	WASHER FLAT 5/16 ZINC
11	0A1646	4	WASHER FLAT M16	31	025966	2	SCREW HHC 1/4-20 X 2-1/2 G5
12	0A4707E	1	ADAPTER 3/8 NPT-M18 X 1.5	32	022127	2	NUT HEX 1/4-20 STEEL
13	0A8584	1	SWITCH OIL PRESSURE	33	033121	2	SCREW HHC #10-32 X 1/2
14	053666	1	SENDER OIL PRESSURE	34	023897	2	WASHER FLAT #10 ZINC
15	0A1693	1	HARNESS ENGINE WIRE	35	022158	2	NUT HEX #10-32 STEEL
16	057522	1	SENSOR COOLANT LEVEL	36	030418	1	BUSHING REDUCER 1/2 TO 3/8
17	053667	1	SENDER WATER TEMPERATURE	37	086096	1	ADAPTER WATER TEMP SENDER
18	035606	1	SENSOR HI COOLANT SHUTDOWN	38	053660	1	BARBED STRAIGHT 1/4 NPT X 5/8
19	0A4854	1	TUBE FUEL RETURN				
20	0A4601	1	ELBOW WATER PUMP 1/2 "				



Exploded View and Parts List

GR-125 Generator Set

Radiator Assembly — Drawing No. 0A5354-E

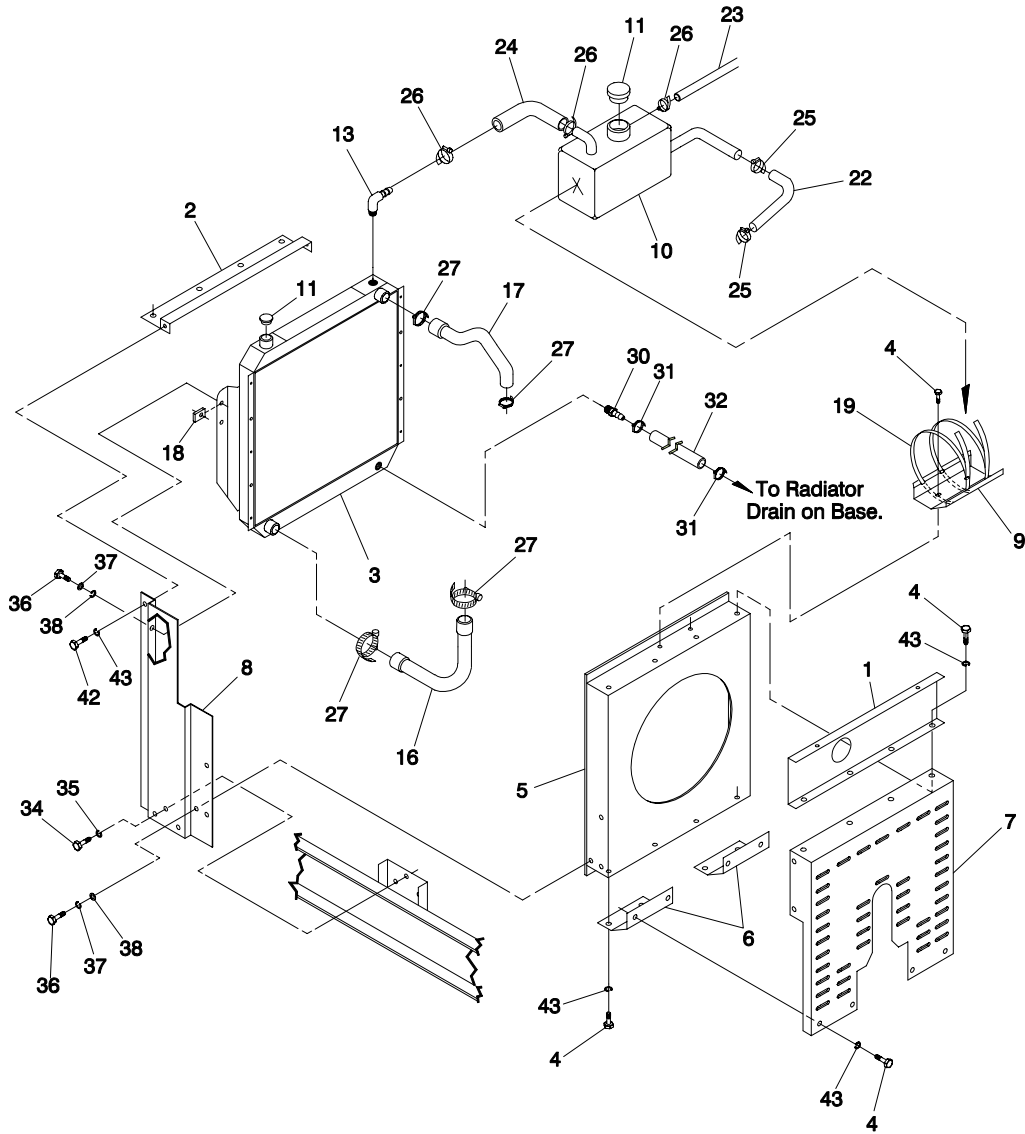

ITEM	PART NO.	QTY.	DESCRIPTION	ITEM	PART NO.	QTY.	DESCRIPTION
1	0A2122B	1	BAFFLE, UPPER RAD.	22	035587	1	HOSE 1IN ID CVR NEOP SAE-20R3
2	099458	2	DUCT TOP/BOTTOM	23	029032	24"	HOSE 9/32 ID
3	087871A	1	RADIATOR OUTLET RH	24	029032	30"	HOSE 9/32 ID
4	022287	16	SCREW HHC 1/4-20 X 3/4 G5	25	057824	2	CLAMP HOSE #16 .87 - 1.50
5	021970A	1	VENTURI 6.8L 4 T JD	26	040173	3	CLAMP HOSE #5.5 .62 - .62
6	0A5350	2	GUARD LOWER FAN	27	042561	4	CLAMP HOSE #36 1.88 - 2.75
7	0A5362	1	GUARD FAN	30	035461	1	BARBED STRAIGHT 1/4 NPT X 3/8
8	021971	1	SUPPORT RADIATOR SIDE RH JD	31	035472	2	CLAMP HOSE #6 .43 - .78
	021972	1	SUPPORT RADIATOR SIDE LH JD	32	047290	30"	HOSE 3/8 ID SINGLE BRAID
9	099448	1	SUPPORT, SURGE TANK	34	052617	6	SCREW HHC M12-1.75 X 20 G8.8
10	090097	1	TANK SURGE	35	051769	6	WASHER LOCK M12
11	046627	2	CAP RADIATOR	36	029745	6	SCREW HHC 3/8-16 X 1 G5
13	059502	1	BARB EL 90 1/4NPT X 5/16	37	022237	12	WASHER LOCK 3/8
16	0A3433	1	HOSE RADIATOR LOWER	38	022131	12	WASHER FLAT M10-3/8 ZINC
17	0A2509	1	HOSE RADITOR UPPER	42	047411	34	SCREW HHC M6-1.0 X 16 G8.8
18	099667D	6	NUT SPRINGCLIP 3/8-16	43	022097	34	WASHER LOCK M6-1/4
19	058612	2	CLAMP HOSE #88 5.12 - 6.00				

Exploded View and Parts List

GR-125 Generator Set

Muffler — Drawing No. 0D2975-A

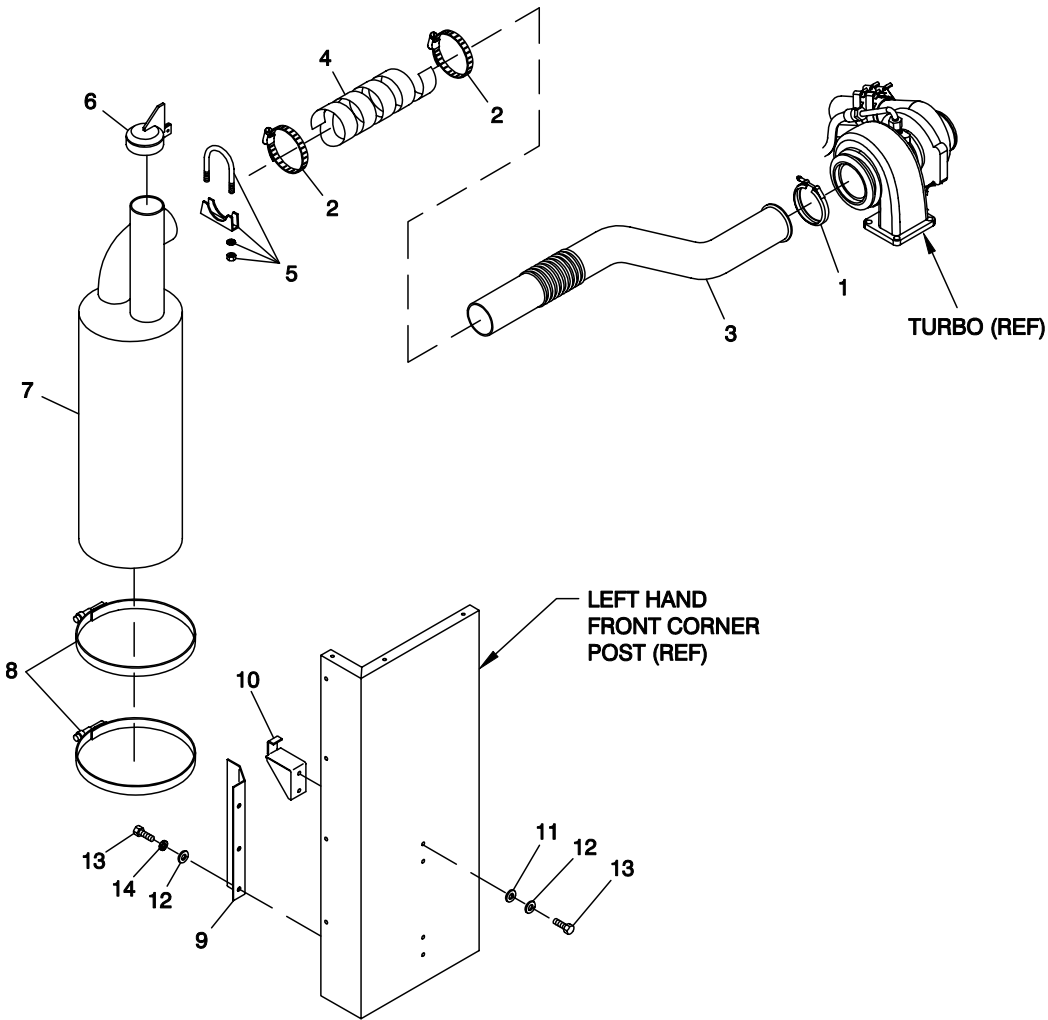
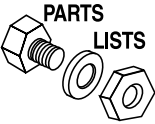

ITEM	PART NO.	QTY.	DESCRIPTION
1	098458	1	EXHAUST CLAMP V-BAND
2	039294	2	CLAMP HOSE #44 2.31 - 3.25
3	0A3930	1	FLEX PIPE 6.8L JD
4	082361	12'	INSULATION-EXHAUST
5	0A5423	1	U BOLT 3.5" CLAMP
6	059940	1	RAIN CAP 3.50 / 3.69
7	0A3929	1	MUFFLER 6.8L JD
8	0A3756	2	CLAMP TEE BOLT 11.25"
9	0A3546	1	BRACKET MUFFLER JD
10	099805	2	BRACKET MUFFLER CL B
11	096210	4	WASHER NYLON .375
12	088775	7	WASHER FLAT 3/8 SS
13	085916	7	SCREW HHC 3/8-16 X 1 SS
14	085917	3	WASHER LOCK 3/8 SS

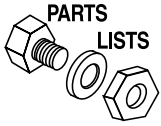

Exploded View and Parts List

GR-125 Generator Set

Battery Charger — Drawing No. 091237-F

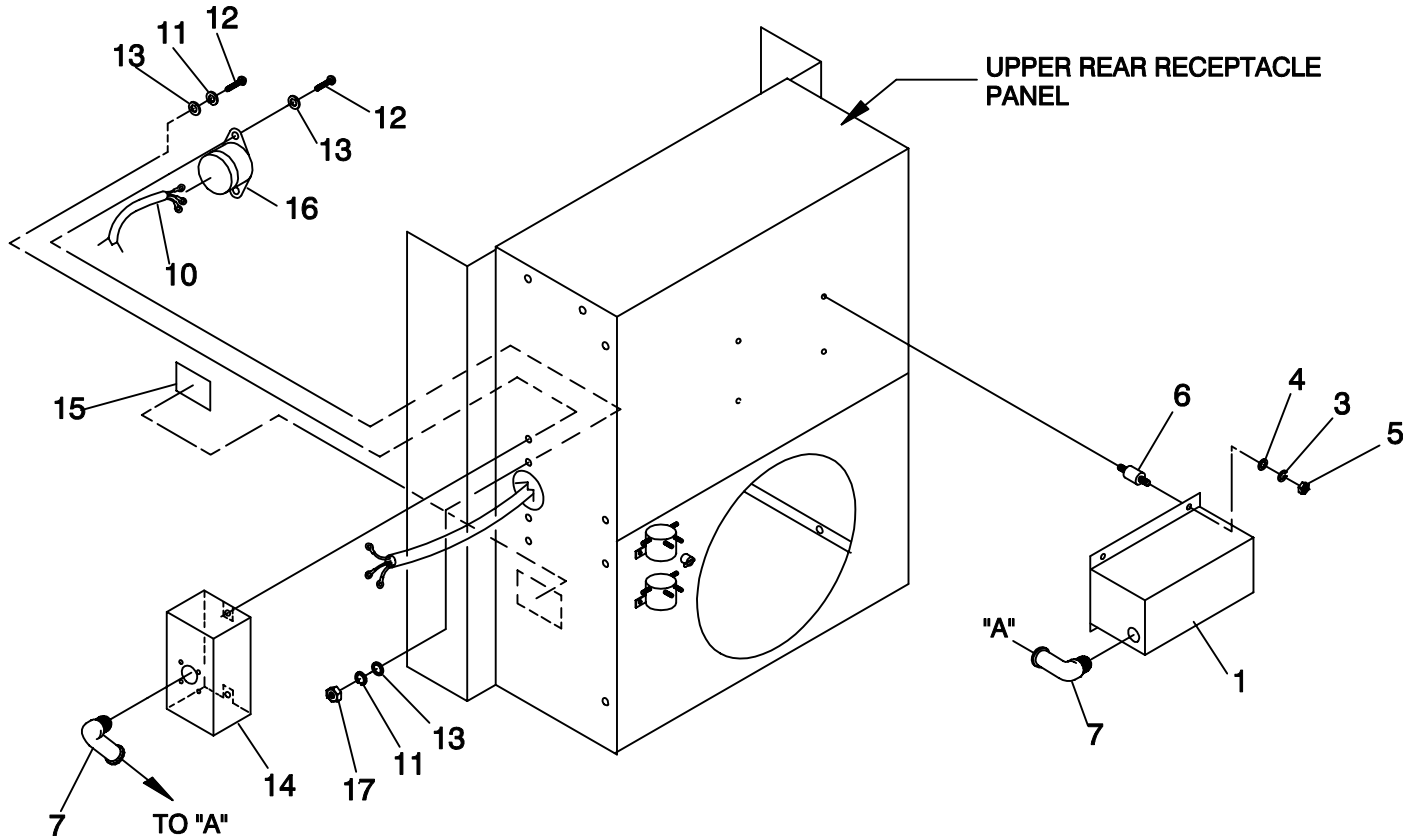

ITEM	PART NO.	QTY.	DESCRIPTION
1	079535	1	ASSEMBLY BATTERY CHARGER 10A12V
	062059	1	ASSEMBLY BATTERY CHARGER 2A/12V
3	022097	4	WASHER LOCK M6-1/4
4	022473	4	WASHER FLAT 1/4 ZINC
5	022127	4	NUT HEX 1/4-20 STEEL
6	027831	4	MOUNT VIBR 1.0 X .50 X 1/4-20
7	060015	2	FITTING 90 DEGREE 3/8
10	088670	1	ASSEMBLY WIRE-BATTERY CHARGER
11	081797	4	WASHER LOCK #6 SS
12	091198	4	SCREW PPHM #6-32 X 5/8 SS
13	081799	8	WASHER FLAT #6-M4 SS
14	062141	1	BOX, HANDY 2.125 DP
15	091233	1	DECAL UTILITY CONNECTION
16	069174	1	RECEPTACLE MALE 5278SS
17	081798	2	NUT HEX #6-32 SSTL
**	055934C	1	CLAMP VINYL .5 X .406 Z
**	090679	1	HARNESS BATTERY CHARGER

** NOT SHOWN

Exploded View and Parts List
GR-125 Generator Set
Block Heater — Drawing No. 0D2112-A

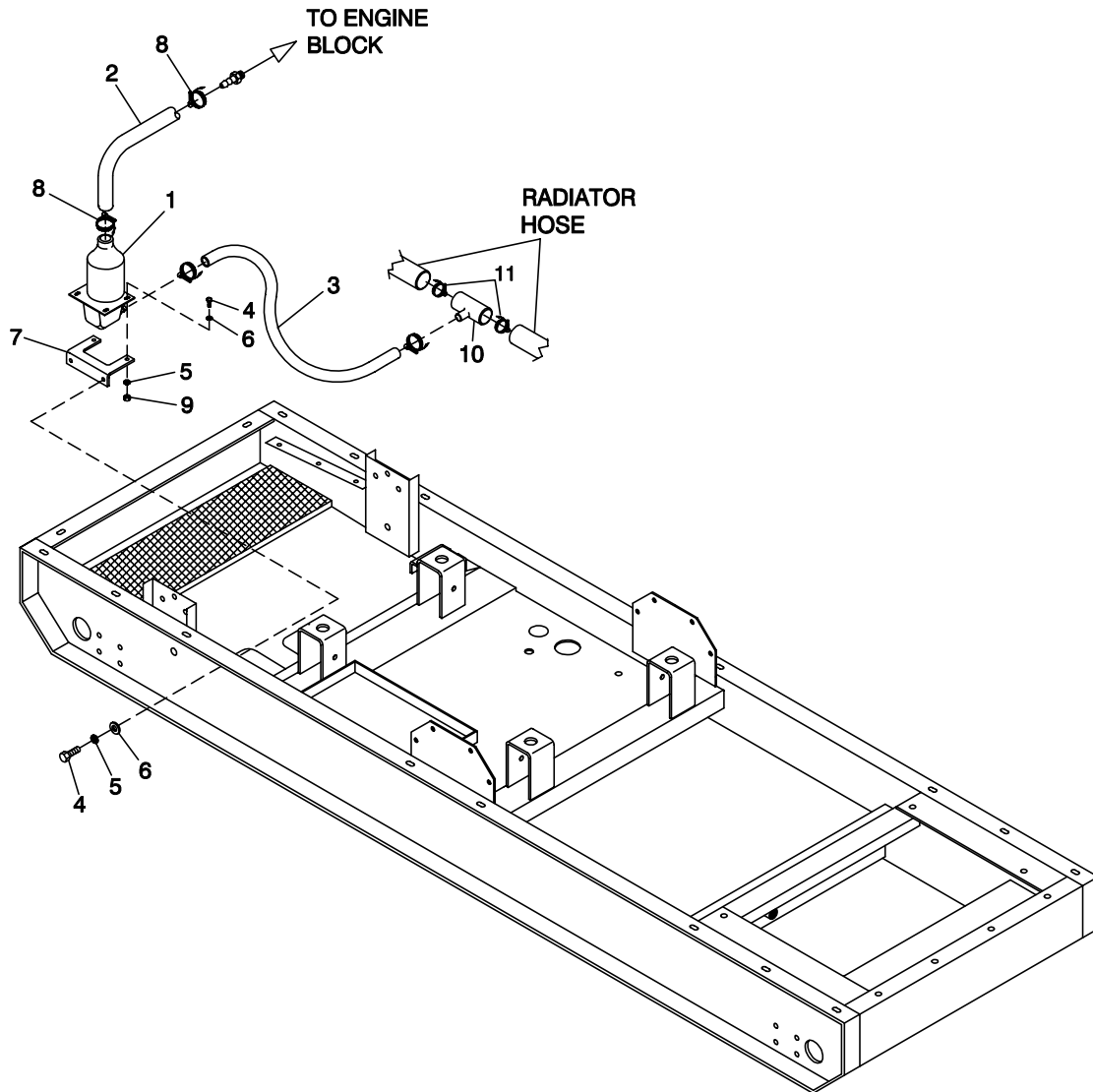
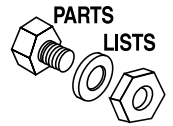

ITEM	PART NO.	QTY.	DESCRIPTION
------	----------	------	-------------

1	084918C	1	BLOCK HEATER 1800W 120V
2	050967	20"	HOSE 5/8 ID RIA 250F
3	050967	24"	HOSE 5/8 ID RIA 250F
4	042568	4	SCREW HHC M6-1.0 X 20 G8.8
5	022097	4	WASHER LOCK M6-1/4
6	049811	4	WASHER FLAT M6
7	084427	1	BRACKET HEATER
8	057822	4	CLAMP HOSE #8 .53 - 1.00
9	049813	2	NUT HEX M6 -1.0 G8 YEL CHR
10	080723	1	HOSE CONNT. 1.75-.62
11	042561	2	CLAMP HOSE #36 1.88 - 2.75

NOTE: PUT ITEM #10 IN RADIATOR HOSE.

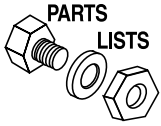

Exploded View and Parts List

GR-125 Generator Set

Air Cleaner — Drawing No. 0A5738-A

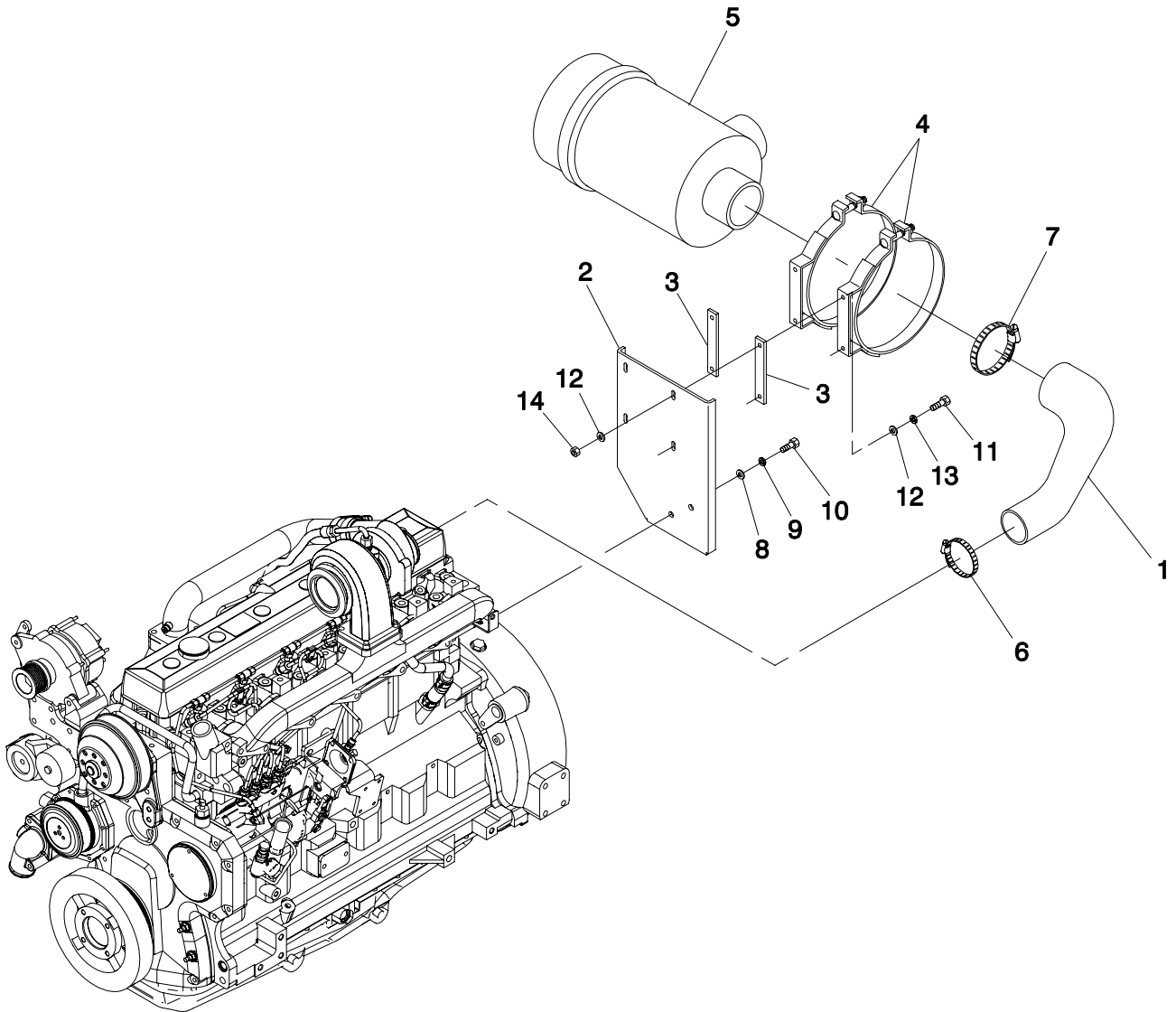

ITEM	PART NO.	QTY.	DESCRIPTION
1	0A4040	1	ELBOW AIR CLEANER 6.8L
2	0A4045	1	BRACKET AIR CLEANER 6.8L JD
3	0A5186	2	SPACER AIR CLEANER BRACKET
4	094194	2	BAND 10" AIR CLEANER MOUNTING
5	094193	1	AIR CLEANER FWG10
6	066212	1	CLAMP HOSE #52 2.81 - 3.75
7	078190	1	CLAMP HOSE #80 4.62 - 5.50
8	022131	2	WASHER FLAT 3/8-M10 ZINC
9	046526	2	WASHER LOCK M10
10	051756	2	SCREW HHC M10-1.5 X 20 G8.8
11	022142	4	SCREW HHC 5/16-18 X 3/4 G5
12	022145	8	WASHER FLAT 5/16 ZINC
13	022129	4	WASHER LOCK M8-5/16
14	022259	4	NUT HEX 5/16-18 STEEL



EMISSION SYSTEM WARRANTY (NON-ROAD DIESEL)

EMISSIONS CONTROL SYSTEM CERTIFICATION LABEL



WARNING: Statutes providing severe penalties for tampering with emissions controls may apply at the user's location.

The emissions warranty described below applies only to those engines marketed by John Deere that have been certified by the United States Environmental Protection Agency (EPA) and/or California Air Resources Board (CARB); and used in the United States and Canada in non-road mobile (self-propelled or portable/transportable*) equipment. The presence of an emissions label like the one shown signifies that the engine has been certified with the EPA and/or CARB. The EPA and CARB warranties only apply to new engines having the certification label affixed to the engine and sold as stated above in the geographic areas. The presence of an EU number in the third line of the label signifies that the engine has been certified with the European Union countries per Directive 97/68/EC. The emissions warranty does not apply to the EU countries.



Note: The hp/kW rating on the engine emissions certification label specifies the gross engine hp/kW, which is flywheel power without fan. In most applications this will not be the same rating as the advertised vehicle hp/kW rating.

* Equipment moved at least once every 12 months.

U.S. EPA EMISSIONS CONTROL WARRANTY STATEMENT

Emissions control-related parts and components are warranted by John Deere for five years or 3000 hours of operation, whichever occurs first. John Deere further warrants that the engine covered by this warranty was designed, built, and equipped so as to conform at the time of sale with all U.S. emissions standards at the time of manufacture, and that it is free of defects in materials and workmanship which would cause it not to meet these standards within the period of five years or 3000 hours of operation, whichever occurs first.

Warranties stated in this manual refer only to emissions-related parts and components of your engine. The complete engine warranty, less emissions-related parts and components, is provided separately as the "John Deere New Off-Highway Engine Warranty".

Part 1



Warranty

GR-125 Generator Set

CALIFORNIA EMISSION CONTROL WARRANTY STATEMENT (CALIFORNIA ONLY)

Your Warranty Rights and Obligations

The California Air Resources Board (CARB) and John Deere are pleased to explain the emission control system on your new engine. In California, new heavy-duty engines must be designed, built, and equipped to meet the State's stringent anti-smog standards. John Deere must warrant the emission control system on your engine for the periods of time listed below provided there has been no abuse, neglect, or improper maintenance of your engine.

Your emissions control system includes:

- Fuel Metering System
 - Fuel Injection System
- Air Induction System
 - Intake Manifold
 - Turbocharger System
 - Charge Air Cooling System
- Miscellaneous Items used in above systems

Where a warrantable condition exists, i.e. failure due to defect in John Deere-supplied material and/or workmanship, John Deere will repair your heavy-duty engine at no cost to you including diagnosis, parts and labor.

JOHN DEERE'S WARRANTY COVERAGE:

The emission control system of your heavy-duty engine is warranted for five years or 3000 hours of operation, whichever occurs first. If any emission-related part on your engine is defective, the part will be repaired or replaced by John Deere. Warranties stated in this manual refer only to emissions-related parts and components of your engine. The complete engine warranty, less emissions-related parts and components, is provided separately as the "John Deere New Off-Highway Engine Warranty".

Part 2

**OWNER'S WARRANTY RESPONSIBILITIES:**

As the heavy-duty engine owner, you are responsible for the performance of the required maintenance as outlined in this Operation and Maintenance Manual. John Deere recommends that you retain all receipts covering maintenance on your heavy-duty engine, but John Deere cannot deny warranty solely for the lack of receipts or for your failure to ensure the performance of all scheduled maintenance.

However, as the heavy-duty engine owner, you should be aware that John Deere may deny you warranty coverage if your heavy-duty engine or a part has failed due to abuse, neglect, improper maintenance or unapproved modifications.

Your engine is designed to operate on diesel fuel only. Use of any other fuel may result in your engine no longer operating in compliance with California's emissions requirements.

You are responsible for initiating the warranty process. The CARB suggests that you present your heavy-duty engine to the nearest John Deere engine service dealer as soon as a problem is suspected. The warranty repairs should be completed by the service dealer as expeditiously as possible.

If you have any questions regarding your warranty rights and responsibilities, you should contact John Deere at 1-319-292-5400 or the State of California Air Resources Board, Mobile Source Operation Division, PO Box 8001, El Monte, CA 91731-2990.

The warranty period begins on the date the engine is delivered to an ultimate purchaser, or when otherwise put into service. John Deere warrants to the ultimate purchaser and each subsequent purchaser that the engine is designed, built, and equipped so as to conform with all applicable regulations adopted by the Air Resources Board, and that it is free from defects in materials and workmanship which would cause the failure of a warranted part.

Any warranted part which is scheduled for replacement as required maintenance by this Operation and Maintenance Manual is warranted by John Deere for the period of time prior to the first scheduled replacement point for that part. If the part fails prior to the first scheduled replacement point, the part shall be repaired or replaced under the warranty. Any such part repaired or replaced under warranty is warranted for the remainder of the period prior to the first scheduled replacement point for the part.

Any warranted part which is not scheduled for replacement as required maintenance, or which is scheduled only for regular inspection to the effect of repairing or replacing as necessary, is warranted for the warranty period.

Repair or replacement of a warranted part will be performed at no charge to you by a John Deere engine service dealer. You will not be charged for diagnostic labor which leads to the determination that a warranted part is defective, if the diagnostic work is performed by a John Deere engine service dealer.

John Deere is liable for damages to other engine components caused by the failure under warranty of any warranted part.

Any replacement part may be used in the performance of any maintenance or repairs, and such use will not reduce the warranty obligations of John Deere. However, the use of add-on or modified parts are grounds for disallowing a warranty claim.

Part 3



Warranty

GR-125 Generator Set

GENERAC POWER SYSTEMS' STANDARD ONE-YEAR LIMITED WARRANTY FOR STANDBY POWER SYSTEMS

NOTE: ALL UNITS MUST BE INSTALLED BY GENERAC POWER SYSTEMS AUTHORIZED SERVICE FACILITIES.

For a period of 1 (one) year or 1,500 (one thousand five hundred) hours of operation from the date of original sale, whichever occurs first, Generac Power Systems, Inc. (Generac) will, at its option, repair or replace any part which, upon examination, inspection and testing by Generac or a Generac Authorized Warranty Service Facility, is found to be defective under normal use and service, in accordance with the warranty schedule set forth below. Any equipment that the purchaser/owner claims to be defective must be examined by the nearest Generac Authorized Warranty Service Facility. All transportation costs under the warranty, including return to the factory, are to be borne and prepaid by the purchaser/owner. This warranty applies only to Generac generators used in "Standby" applications, as Generac has defined Standby, provided said generators have been initially installed and inspected on-site by a Generac Authorized Service Dealer or branch thereof.

WARRANTY SCHEDULE

YEAR ONE - 100% (one hundred percent) coverage on mileage*, labor and parts listed:

- **Engine** - All components
- **Alternator** - All components
- **Transfer System** - All components

**Travel allowance is limited to 300 miles or 7.5 hours maximum, round trip, and applies only to permanently wired and mounted units.*

All warranty expense allowances **are** subject to the conditions defined in Generac's *Warranty Policies, Procedures and Flat Rate Manual*.

Units that have been resold **are not** covered under the Generac warranty, as this warranty is not transferable.

THIS WARRANTY SHALL NOT APPLY TO THE FOLLOWING:

- Costs of normal maintenance, adjustments, installation and start-up.
- Units sold, rated or used for "Prime Power" applications as Generac has defined Prime Power. Contact a Generac Authorized Service Dealer for Prime Power definition and warranty.
- Failures due, but not limited, to normal wear and tear, accident, misuse, abuse, negligence or improper installation.
- Failures caused by any external cause or act of God, such as collision, theft, vandalism, riot or wars, nuclear holocaust, fire, freezing, lightning, earthquake, windstorm, hail, volcanic eruption, water or flood, tornado or hurricane.
- Products that are modified or altered in a manner not authorized by Generac in writing.
- Any incidental, consequential or indirect damages caused by defects in materials or workmanship, or any delay in repair or replacement of the defective part(s).
- Failure due to misapplication.
- Telephone, telegraph, teletype or other communication expenses.
- Living or travel expenses of person(s) performing service, except as specifically included within the terms of a specific unit warranty period.
- Rental equipment used while warranty repairs are being performed.
- Overnight freight costs for replacement part(s).
- Overtime labor.
- Starting batteries, fuses, light bulbs and engine fluids.

THIS WARRANTY IS IN PLACE OF ALL OTHER WARRANTIES, EXPRESSED OR IMPLIED. SPECIFICALLY, GENERAC MAKES NO OTHER WARRANTIES AS TO THE MERCHANTABILITY OR FITNESS FOR A PARTICULAR PURPOSE. Some states do not allow limitations on how long an implied warranty lasts, so the above limitation may not apply to you.

GENERAC'S ONLY LIABILITY SHALL BE THE REPAIR OR REPLACEMENT OF PART(S) AS STATED ABOVE. IN NO EVENT SHALL GENERAC BE LIABLE FOR ANY INCIDENTAL OR CONSEQUENTIAL DAMAGES, EVEN IF SUCH DAMAGES ARE A DIRECT RESULT OF GENERAC'S NEGLIGENCE. Some states do not allow the exclusion or limitation of incidental or consequential damages, so the above limitation may not apply to you. Purchaser/owner agrees to make no claims against Generac based on negligence.

This warranty gives you specific legal rights. You also may have other rights that vary from state to state.