

GENERAC®

POWER SYSTEMS, INC.

Operation and Maintenance Manual

Liquid-cooled,
Diesel Engine
Standby Generators
Model No. 04197-0

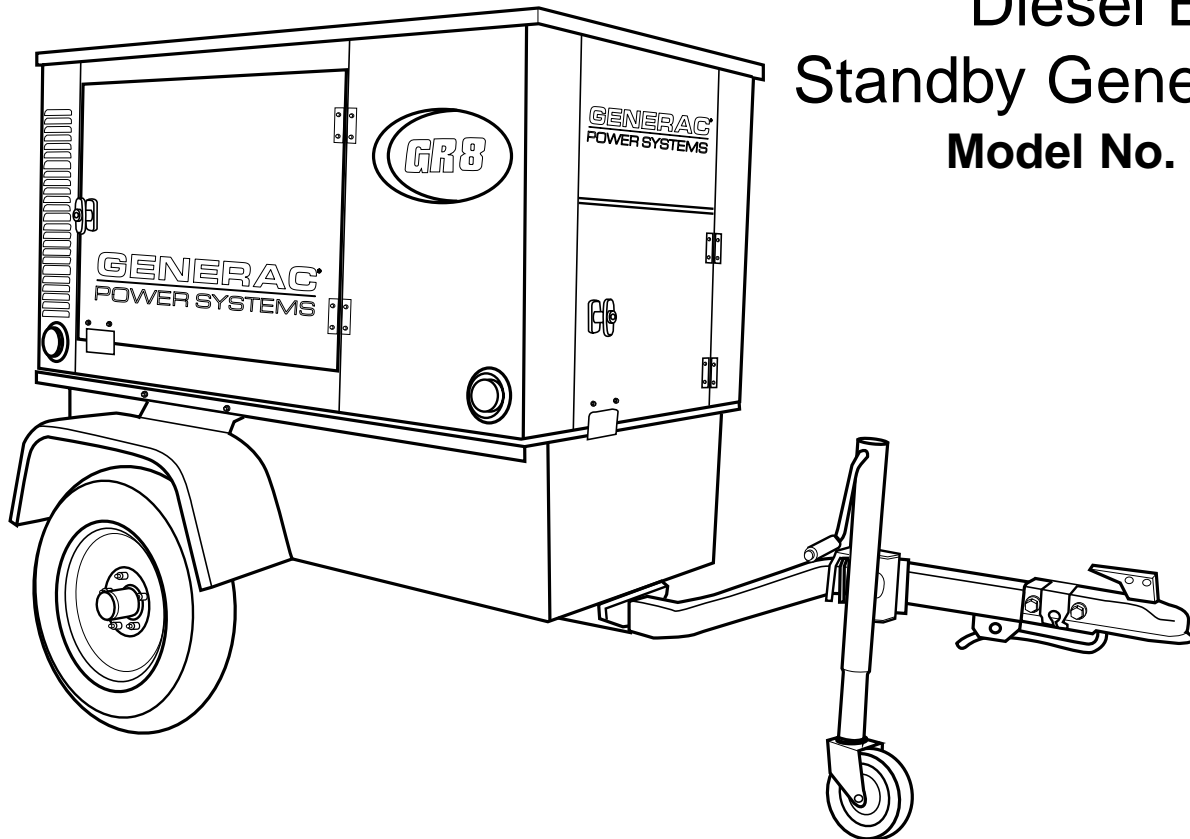

—▲ DANGER ▲—

ONLY QUALIFIED ELECTRICIANS OR CONTRACTORS
SHOULD ATTEMPT INSTALLATION!!

INTRODUCTION

This Owner's Manual was prepared especially for the purpose of familiarizing personnel with the operation and servicing of the applicable equipment.

Every effort was expended to make sure that the information and instructions in this manual are both accurate and current at the time the manual was written. However, the manufacturer reserves the right to change, alter or otherwise improve product(s) at any time without prior notice.



CAUTION: Read all instructions and safety rules before attempting to operate or service this (and related) equipment. Protect yourself and others by strictly complying with these instructions and rules. Failure to comply with these safety rules may result in personal injury, death or damage to equipment and/or property. Retain these instructions for future reference.

◆ READ THIS MANUAL THOROUGHLY

If you do not understand any portion of this manual, contact Generac or your nearest Generac Authorized Dealer for starting, operating and servicing procedures.

Throughout this publication, and on tags and decals affixed to the generator, DANGER, WARNING, CAUTION, and NOTE blocks are used to alert you to special instructions about a particular operation that may be hazardous if performed incorrectly or carelessly. Observe them carefully. Their definitions are as follows:



After this heading, you can read instructions that, if not strictly complied with, will result in personal injury or property damage.



After this heading, you can read instructions that, if not strictly complied with, may result in personal injury or property damage.



After this heading, you can read instructions that, if not strictly complied with, could result in damage to equipment and/or property.

NOTE:

After this heading, you can read explanatory statements that require special emphasis.

These safety warnings cannot eliminate the hazards that they indicate. Common sense and strict compliance with the special instructions while performing the service are essential to preventing accidents.

Four commonly used safety symbols accompany the DANGER, WARNING and CAUTION blocks. The type of information each indicates follows:



This symbol points out important safety information that, if not followed, could endanger personal safety and/or property of you and others.



This symbol points out potential explosion hazard.



This symbol points out potential fire hazard.



This symbol points out potential electrical shock hazard.

The operator is responsible for proper and safe use of the equipment. We strongly recommend that the operator read the *Owner's Manual* and thoroughly understand all instructions before using this equipment. We also strongly recommend instructing other users to properly start and operate the unit. This prepares them if they need to operate the equipment in an emergency.

◆ OPERATION AND MAINTENANCE

It is the operator's responsibility to perform all safety checks, to make sure that all maintenance for safe operation is performed promptly, and to have the equipment checked periodically by a Generac Authorized Dealer. Normal maintenance service and replacement of parts are the responsibility of the owner/operator and, as such, are not considered defects in materials or workmanship within the terms of the warranty. Individual operating habits and usage contribute to the need for maintenance service.

Proper maintenance and care of your generator ensures a minimum number of problems and keeps operating expenses at a minimum. See your Generac Authorized Dealer for service aids and accessories.

◆ HOW TO OBTAIN SERVICE

When your generator requires servicing or repairs, simply contact a Generac Authorized Dealer for assistance. Service technicians are factory-trained and are capable of handling all of your service needs.

When contacting a Generac Authorized Dealer or the factory about parts and service, always supply the complete model number and serial number of your unit as given on its data decal, which is located on the control panel mounting bracket.

◆ REPORTING SAFETY DEFECTS

If you believe that your vehicle has a defect which could cause a crash or could cause injury or death, you should immediately inform the National Highway Traffic Safety Administration (NHTSA) in addition to notifying Generac Power Systems Inc.

If NHTSA receives similar complaints, it may open an investigation, and if it finds that a safety defect exists in a group of vehicles, it may order a recall and remedy campaign. However, NHTSA cannot become involved in individual problems between you, your dealer, or Generac Power Systems Inc.

To contact NHTSA, you may either call the Auto Safety Hotline toll-free at 1-800-424-9393 (or 336-0123 in Washington, DC area) or Write to: NHTSA, U.S. Department of Transportation, Washington DC 20590. You can also obtain other information about motor vehicle safety from the Hotline.

AUTHORIZED DEALER LOCATION

To locate the GENERAC AUTHORIZED DEALER nearest you, please call this number:

1-800-333-1322

DEALER LOCATION INFORMATION
CAN BE OBTAINED AT THIS NUMBER.

<p>IntroductionInside Front Cover</p> <p> Read This Manual ThoroughlyIFC</p> <p> Operation and Maintenance.....IFC</p> <p> How to Obtain Service.....IFC</p> <p> Reporting Safety DefectsIFC</p> <p> Authorized Dealer Location Number.....IFC</p> <p>Safety Rules2</p> <p>Section 1 – General Information.....4</p> <p> 1.1 Identification Record.....4</p> <p> 1.1.1 Data Plate4</p> <p> 1.2 Equipment Description.....4</p> <p> 1.2.1 Standard Generator Features4</p> <p> 1.3 Specifications4</p> <p> 1.3.1 Engine4</p> <p> 1.3.2 Generator5</p> <p>Section 2 – Installation5</p> <p> 2.1 Installation5</p> <p> 2.1.1 Standby Electric System5</p> <p> 2.1.2 Emergency Circuit Isolation6</p> <p> 2.1.3 Total Circuit Isolation7</p> <p> 2.1.4 Generator AC Connections7</p> <p> 2.2 Connection Panel.....7</p> <p> 2.2.1 Generator Receptacles.....7</p> <p> 2.2.2 Main Terminal Block.....7</p> <p> 2.2.3 120/240 Single Phase 30A Locking Type Receptacle7</p> <p> 2.2.4 Cord Sets - 120 Volts GFCI Duplex Receptacles7</p> <p> 2.2.5 Auxiliary Supply7</p> <p> 2.2.6 Battery Charger8</p> <p> 2.2.7 Engine Heater8</p> <p> 2.2.8 Remote Start8</p> <p> 2.2.9 Remote Alarm Signal.....8</p> <p>Section 3 – Operation8</p> <p> 3.1 Preparation Before Use8</p> <p> 3.1.1 Engine Lubrication8</p> <p> 3.1.2 Engine Coolant8</p> <p> 3.1.3 Fuel8</p> <p> 3.2 Operating Instructions9</p> <p> 3.2.1 Before Starting9</p> <p> 3.2.2 Starting the Engine9</p> <p> 3.2.3 Shut Down9</p> <p> 3.3 Applying the Load9</p> <p> 3.4 Engine Control Operation9</p> <p> 3.4.1 Cranking and Start Up9</p> <p> 3.4.2 After a Shutdown Failure9</p> <p> 3.5 Generator Meter and Control Panel.....10</p> <p> 3.5.1 Panel Light Switch.....10</p> <p> 3.5.2 AC Ammeter10</p> <p> 3.5.3 Panel Lights.....10</p> <p> 3.5.4 Frequency Meter10</p> <p> 3.5.5 Voltage Adjust Potentiometer.....10</p>	<p> 3.5.6 Voltage & Current/Circuit Selector Switch10</p> <p> 3.5.7 Fault Indicator Lamp.....11</p> <p> 3.5.8 Preheat Button11</p> <p> 3.5.9 Start/Stop Switch11</p> <p> 3.5.10 Auto/Off/Manual Switch.....11</p> <p> 3.5.11 15 Amp Fuse (DC Control)11</p> <p> 3.5.12 Hourmeter.....11</p> <p> 3.5.13 DC Voltmeter.....11</p> <p> 3.5.14 Oil Pressure Gauge11</p> <p> 3.5.15 Coolant Temperature Gauge11</p> <p> 3.5.16 AC Voltmeter11</p> <p> 3.6 Engine Protective Shutdown Devices.....11</p> <p> 3.6.1 Low Oil Pressure Switch11</p> <p> 3.6.2 High Coolant Temperature Switch ..11</p> <p> 3.6.3 Overspeed12</p> <p> 3.6.4 Low Coolant Level.....12</p> <p> 3.6.5 Engine Startup12</p> <p> 3.7 Grounding the Generator12</p> <p> 3.8 Ground Fault Protection12</p> <p> 3.8.1 Testing the GFCI13</p> <p> 3.9 Operation in Ice or Snow13</p> <p>Section 4 – Maintenance13</p> <p> 4.1 Maintenance13</p> <p> 4.1.1 25 Hour Break-in Period13</p> <p> 4.1.2 25 Hour Check Up13</p> <p> 4.2 Checking Fluid Levels14</p> <p> 4.2.1 Engine Crankcase Oil14</p> <p> 4.2.2 Engine Coolant14</p> <p> 4.2.3 Fuel14</p> <p> 4.2.4 Battery Electrolyte Fluid15</p> <p> 4.3 Engine Oil15</p> <p> 4.4 Fuel Requirements15</p> <p> 4.5 Engine Coolant15</p> <p> 4.6 Owner/Operator Maintenance15</p> <p> 4.7 Cleaning the Generator16</p> <p> 4.8 Adjustments16</p> <p> 4.9 Generator Rotor Bearing.....16</p> <p> 4.10 Freezing Temperature Operation.....16</p> <p> 4.11 Effects of Moisture and Dirt16</p> <p> 4.12 Service Facility Maintenance17</p> <p> 4.13 Major Repairs17</p> <p> 4.13.1 How to Order Parts17</p> <p>Section 5 – Troubleshooting18</p> <p> 5.1 Troubleshooting Guide18</p> <p>Section 6 – Notes19</p> <p>Section 7 – Electrical Data20</p> <p>Section 8 – Exploded Views and Parts Lists24</p> <p>Section 9 – Warranty40</p>
---	---



SAVE THESE INSTRUCTIONS - The manufacturer suggests that these rules for safe operation be copied and posted near the unit's installation site. Safety should be stressed to all operators and potential operators of this equipment.

**WARNING:**

The engine exhaust from this product contains chemicals known to the state of California to cause cancer, birth defects or other reproductive harm.

**WARNING:**

This product contains or emits chemicals known to the state of California to cause cancer, birth defects or other reproductive harm.

Study these SAFETY RULES carefully before connecting, operating or servicing this equipment. Become familiar with this *Installation, Start-up and Adjustment Manual* and with the unit. The generator can operate safely, efficiently and reliably only if it is properly connected, operated and maintained. Many accidents are caused by failing to follow simple and fundamental rules or precautions.

Generac cannot possibly anticipate every possible circumstance that might involve a hazard. The warnings in this manual, and on tags and decals affixed to the unit are, therefore, not all-inclusive. If you use a procedure, work method or operating technique Generac does not specifically recommend, you must satisfy yourself that it is safe for you and others. You also must make sure the procedure, work method or operating technique that you choose does not render the generator unsafe.

— **DANGER** —

! Despite the safe design of this generator, operating this equipment imprudently, neglecting its maintenance or being careless can cause possible injury or death. Permit only responsible and capable persons to operate or maintain this equipment.

⚡ Potentially lethal voltages are generated by these machines. Ensure all steps are taken to render the machine safe before attempting to work on the generator.

! Parts of the generator are rotating and/or hot during operation. Exercise care near running generators.

**GENERAL HAZARDS**

- For safety reasons, Generac recommends that the initial start-up and maintenance of this equipment be carried out by a Generac Authorized Dealer.
- The engine exhaust fumes contain carbon monoxide, which can be DEADLY. This dangerous gas, if breathed in sufficient concentrations, can cause unconsciousness or even death. This unit should be operated outside only.
- Keep hands, feet, clothing, etc., away from drive belts, fans, and other moving or hot parts. Never remove any drive belt or fan guard while the unit is operating.
- Adequate, unobstructed flow of cooling and ventilating air is critical to correct generator operation. Do not alter the installation or permit even partial blockage of ventilation provisions, as this can seriously affect safe operation of the generator.
- When working on this equipment, remain alert at all times. Never work on the equipment when you are physically or mentally fatigued.
- Inspect the generator regularly, and contact your nearest Generac Authorized Dealer for parts needing repair or replacement.
- Before performing any maintenance on the generator, disconnect its battery cables to prevent accidental start up. Disconnect the cable from the battery post indicated by a NEGATIVE, NEG or (-) first. Reconnect that cable last.
- Never use the generator or any of its parts as a step. Stepping on the unit can stress and break parts, and may result in dangerous operating conditions from leaking exhaust gases, fuel leakage, oil leakage, etc.



ELECTRICAL HAZARDS

- All generators covered by this manual produce dangerous electrical voltages and can cause fatal electrical shock. Utility power delivers extremely high and dangerous voltages to the transfer switch as does the standby generator when it is in operation. Avoid contact with bare wires, terminals, connections, etc., while the unit is running. Ensure all appropriate covers, guards and barriers are in place before operating the generator. If you must work around an operating unit, stand on an insulated, dry surface to reduce shock hazard.
- Do not handle any kind of electrical device while standing in water, while barefoot, or while hands or feet are wet. **DANGEROUS ELECTRICAL SHOCK WILL RESULT.**
- The National Electrical Code (NEC) requires the frame and external electrically conductive parts of the generator to be connected to an approved earth ground. Local electrical codes also may require proper grounding of the generator electrical system.
- After connecting this unit with an automatic transfer switch, the generator may crank and start at any time without warning. When this occurs, load circuits are transferred to the STANDBY (generator) power source. To prevent possible injury if such a start and transfer occur, always set the generator's Auto/Off/Manual switch to its OFF position before working on equipment and disconnect the battery.
- In case of accident caused by electric shock, immediately shut down the source of electrical power. If this is not possible, attempt to free the victim from the live conductor. **AVOID DIRECT CONTACT WITH THE VICTIM.** Use a nonconducting implement, such as a rope or board, to free the victim from the live conductor. If the victim is unconscious, apply first aid and get immediate medical help.
- Never wear jewelry when working on this equipment. Jewelry can conduct electricity resulting in electric shock, or may get caught in moving components causing injury.

FIRE HAZARDS

- For fire safety, the generator must be connected and maintained properly. Operation always must comply with applicable codes, standards, laws and regulations. Adhere strictly to local, state and national electrical codes. Comply with regulations the Occupational Safety and Health Administration (OSHA) has established. Also, ensure that the generator is connected in accordance with the manufacturer's instructions and recommendations.
- Keep a fire extinguisher near the generator at all times. Extinguishers rated "ABC" by the National Fire Protection Association are appropriate for use. Keep the extinguisher properly charged and be familiar with its use. If you have any question pertaining to fire extinguishers, consult your local fire department.

EXPLOSION HAZARDS

- Do not smoke around the generator. Wipe up any fuel or oil spills immediately. Ensure that no combustible materials are left in the generator compartment, or on or near the generator, as FIRE or EXPLOSION may result. Keep the area surrounding the generator clean and free from debris.
- Inspect the fuel system and tank frequently to ensure there are no leaks.

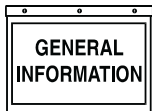

1.1 IDENTIFICATION RECORD

◆ 1.1.1 DATA PLATE

Every generator has a DATA PLATE which contains important information pertinent to the generator. The data plate lists the unit's model number, serial number, its rated voltage, amps, wattage capacity, phase, frequency, rpm, power factor, etc.

The generator model number is the key to numerous engineering and manufacturing details pertaining to your unit. Always supply this number when requesting service, ordering parts, or seeking information.

1.2 EQUIPMENT DESCRIPTION

This equipment is a revolving field, alternating current generator set. The generator is designed to supply electrical power for the operation of compatible, electrical loads when Utility Power is unavailable.

The generator's revolving field is directly connected to and driven by a 1.0 liter diesel fueled engine by means of flexible discs and a coupling assembly. Units with 4-pole Rotors are driven at speeds of 1800 rpm to supply a rated frequency of 60 Hz.

The units are mounted on over-the-highway trailers equipped with breakaway safety chains and a jockey wheel. Weather-resistant, all-metal, sound-attenuated enclosures protect the units against the elements while substantially reducing noise.

◆ 1.2.1 STANDARD GENERATOR FEATURES

This generator incorporates the following features:

- The unit meets temperature rise standards for Class "F" insulation as defined by NEMA MG1-22.4 and NEMA MG1-1.65.
- The generator system incorporates "thermal overload protection."
- The generator is self-ventilated and drip-proof constructed.
- The voltage waveform deviation, total harmonic content of the AC waveform and "telephone influence factor" have been evaluated and are acceptable according to NEMA MG1-22.
- A state of the art magnetic circuit provides minimal level of waveform distortion and a electro-magnetic interference level which meets accepted requirements for standard AM radio, TV and marine radio telephone applications.

1.3 SPECIFICATIONS

Refer to the DATA PLATE on your particular generator for rated watts (kW), rated maximum amperes, rated AC frequency, rated voltage, rated phase and other pertinent information.

◆ 1.3.1 ENGINE

TypeDiesel
 Cylinders and Arrangement3, in-line
 Displacement954cc (58.2 cu.in)
 Bore75mm (2.95 inches)
 Stroke72mm (2.85 inches)
 Compression Ratio23 to 1
 Intake AirNaturally Aspirated
 No. of Main Bearings4
 Governed Engine SpeedSee DATA PLATE
 Rated Horsepower at 1800 rpm12.6

Engine Lubrication System

Type of Oil PumpGear
 Oil FilterFull Flow Cartridge
 Crankcase and Filter
 Oil Capacity.....3.5 liters (3.7 U.S. quarts)

Cooling System

TypePressurized, closed recovery
 Coolant Capacity
 System6.6 liters (1.75 U.S. gallons)
 Engine2.8 liters (.75 U.S. gallons)
 Radiator3.8 liters (1.0 U.S. gallons)
 Coolant Flow Per Minute
 At 1800 rpm.....30 liters (8 U.S. gallons)
 Heat Rejection to Coolant.....35,000 BTU/hr.
 Cooling FanPusher type
 Diameter of Fan380mm (15 inches)

Intake Air Flow Required

60 Hz.43.8m³/min. (1,540 cfm)

Exhaust System

Exhaust Flow Rated Output at 60 Hz....2.1m³/min. (75 cfm)
 Exhaust Temperature at Rated Output.....510°C (950°F)

Engine Electrical System

DC Alternator Output10 amps at 12 volts
 Starter Motor12 volt DC
 Recommended Battery(1) 12 volt, 75 A.H., 26F
 Ground PolarityNegative (-)

Fuel Consumption

Model	25%	50%	75%	100%
GR8 at 60 Hz. (gph)	.35	.52	.63	.84
(liters per hour)	1.3	2.0	2.4	3.2

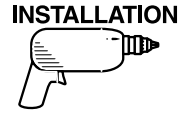

◆ 1.3.2 GENERATOR

Rated Max. Cont. AC Power Output	8,000 watts (8kW)
Phase	Single-Phase
Power Factor	1.0
AC Output Voltage	
Single-Phase	120/240 volts
Rated Maximum Continuous Load Current	
At 240 volts, Single-Phase	33 AC amperes
Rated AC Frequency	60 Hertz at 1800 rpm
Number of Rotor Poles	4
Rotor Speed at No Load	1860 RPM

2.1 INSTALLATION

◆ 2.1.1 STANDBY ELECTRIC SYSTEM

A standby electric system may be defined as a system in which the generator is used to operate critical electrical loads normally powered by a utility power source when the utility power source fails.

- If you are going to use the units to operate electrical loads in standby system applications, the units may be used up to their rated capacity. If the total electrical power demanded by all loads in a system is greater than the rated limit, you can only power essential or key loads (up to the stated capacity) during a utility power outage.

- Generac does not recommend installing or operating a trailer mounted generator indoors. Other units are available which are better suited for indoor installations.
- A double throw transfer switch is required in standby electric system applications to prevent electrical feedback between the generator and the utility power circuit.
- Figure 2.1 illustrates a typical standby electric system. Figure 2.2 (on page 6) shows a schematic diagram of such a system. The transfer switch is used to select which power supply (generator or utility) will operate load circuits in such a system. The transfer switch also prevents load circuits from being connected to both power supplies at the same time.
- If the installer has not installed a transfer switch and modified the electric system as shown in Figure 2.2, plug critical electrical devices (furnace, fan, sump pump, water pump, etc.) directly into one of the generator's output receptacles.
- If the electrician has installed a transfer switch and a connection box, use a suitable, approved cord set between the connection box and a suitable generator receptacle, or between the connection box and the generator's full capacity terminal studs.

Figure 2.1 — A Typical Standby Electric Power System

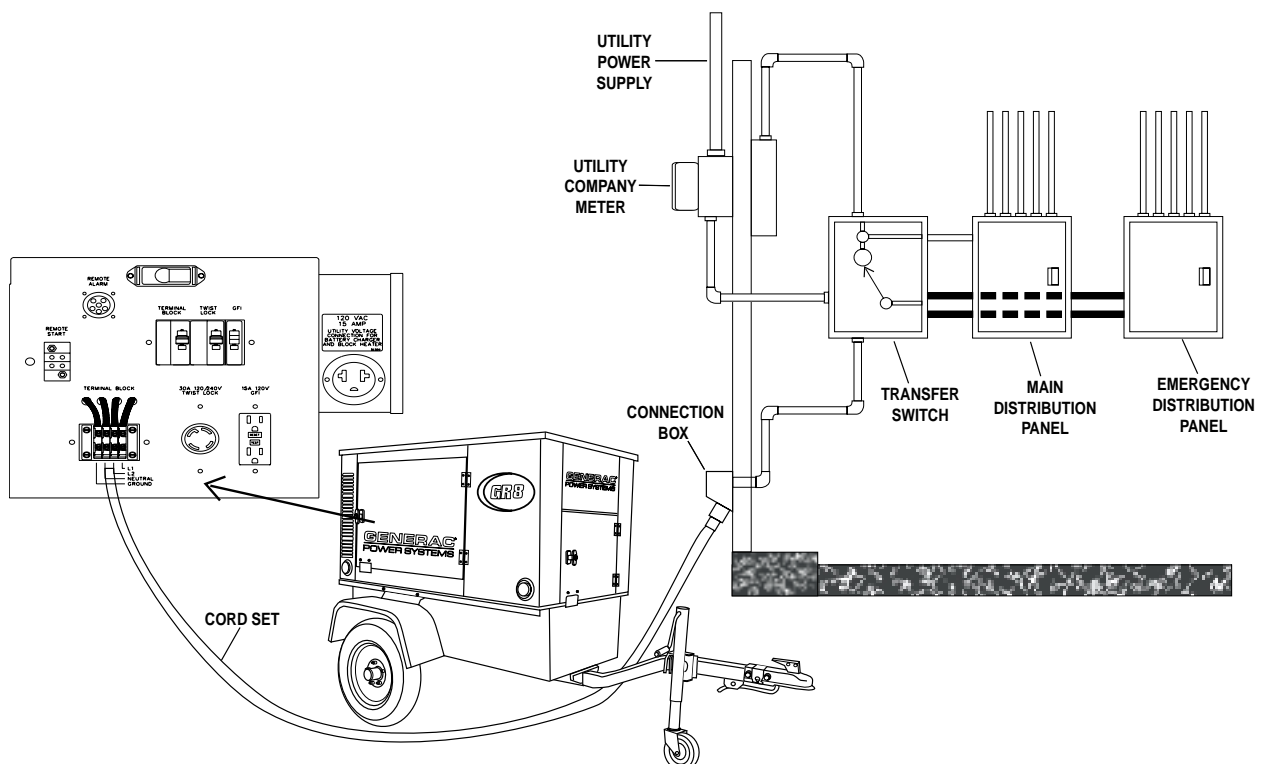

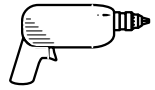

⚠ DANGER ⚠

⚠ DANGER: If existing electrical circuits in a building are normally powered by the utility source, the installer must provide a positive means of making sure that both power supplies never feed to the load circuits at the same time.

- Never connect the generator output to any live building circuits. If the generator is connected to any existing electrical circuit during a commercial power outage, a positive method of isolating the two power supplies must be provided. The usual method of isolating the circuits is by means of a double throw transfer switch.

Figure 2.2 — Simple Standby Electric System

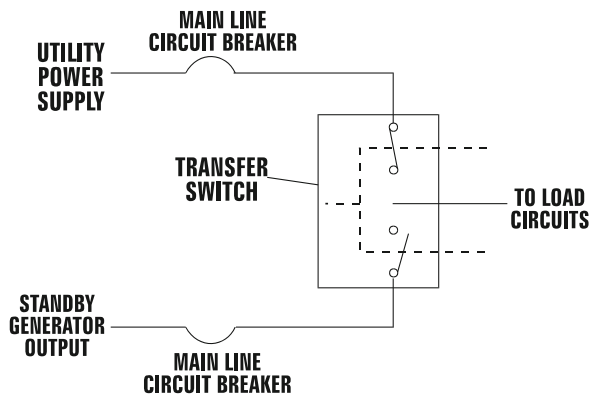

⚠ DANGER ⚠

⚠ DANGER! A hazard exists during a power outage if the generator is connected to dead building circuits and no method of positively isolating circuits is provided.

⚡ Power company workers attempting to restore utility power will open a switch between the main power supply and the spot where they are working. If the home or building electrical circuits are not isolated from the utility supply, generator AC output will back-feed through the building electrical circuits and up the power line. A power company worker may be electrocuted.

⚡ If utility and generator power are not isolated and utility power is suddenly restored while the generator is powering load circuits, the generator can be severely damaged.

◆ 2.1.2 EMERGENCY CIRCUIT ISOLATION

One isolation method is to have emergency circuits (important or essential items to be powered during a utility outage) grouped together and rewired into a separate “emergency distribution panel” (Figure 2.3). Using this method helps prevent accidental overloading of the generator or the specific generator receptacle in use.

Loads fed by this emergency distribution panel must not exceed the wattage/amperage rating of the generator.

A transfer switch having an ampere rating equal to the ampere rating of the emergency circuit would be connected between the building’s main electrical distribution panel and the emergency distribution panel.

Figure 2.3 — Emergency Circuit Isolation

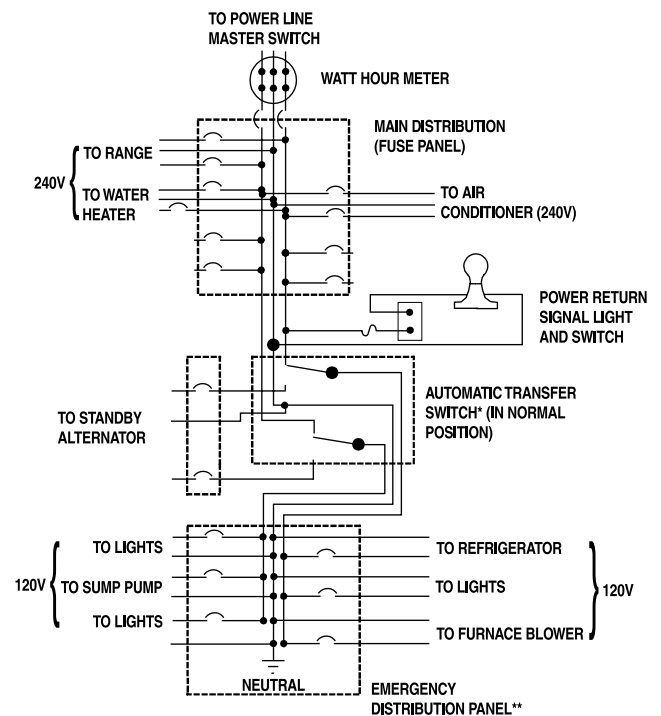

* Ampere rating must be equal to or exceed the ampere rating of the emergency distribution panels.

** Ampere capacity not to exceed the alternator rating. Only these items will be powered by the standby alternator. If the electrician sizes the load properly, the alternator cannot be overloaded.

All wiring must conform to the United States National Electrical Code (NEC) and all state and local codes. Consult a qualified licensed electrician.

The above illustration assumes the utility is supplying 120/240 volt single phase electric service.

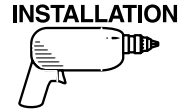

◆ 2.1.3 TOTAL CIRCUIT ISOLATION

If the emergency circuits (Figure 2.4) are not or cannot be wired together in a separate emergency distribution panel, you will have to select the circuits and specific appliances to be powered by the generator during a utility power failure. When this is done, take care to avoid overloading the generator.

When using the total circuit isolation method, the ampere rating of the transfer switch must equal the rating of the normal incoming utility service.

Figure 2.4 — Total Circuit Isolation Method

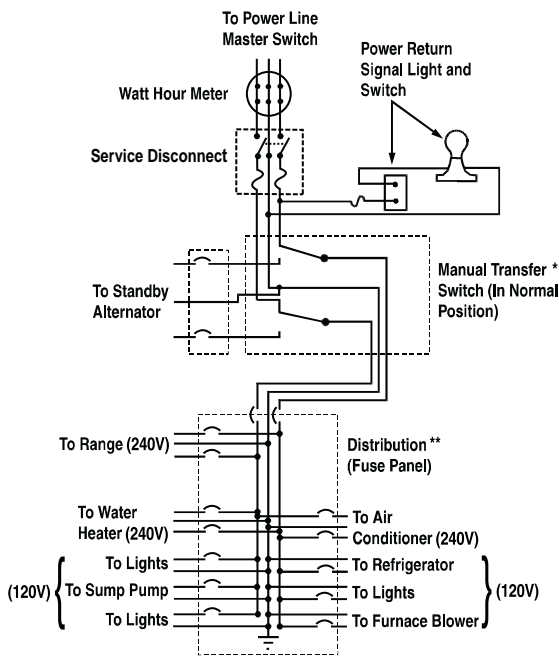

*Ampere rating must be equal to or larger than main (normal) utility entrance service.

**With this system take care to prevent overloading the alternator. During utility power failure, turn OFF individually all load items to distribution panel. Only certain items can be turned back on during alternator operation. Have your electrician specify these items so you do not overload the alternator. All wiring must conform to the United States National Electrical Code (NEC) and all state and local codes. Consult a qualified licensed electrician. The above illustration assumes the utility is supplying 120/240 volt single phase electric service.

◆ 2.1.4 GENERATOR AC CONNECTIONS

Figure 2.5 — Generator AC Connection System

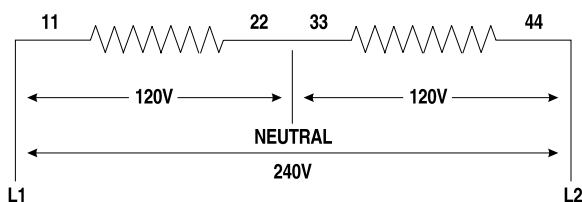

These models are capable of producing 120V and 240V.

2.2 CONNECTION PANEL

◆ 2.2.1 GENERATOR RECEPTACLES

Use the generator receptacles properly. The generator is not an unlimited source of electrical power, nor can individual receptacles supply unlimited power. All receptacles are protected against overload by circuit breakers. (Figure 2.6 on page 8).

◆ 2.2.2 MAIN TERMINAL BLOCK

A set of four compression type terminals are provided for main outlet of the generator power. These are protected by a 35A circuit breaker (CB2). Full generator output (33A) is available from these terminals marked L1, L2, Neutral and Ground (see Figure 2.6 on page 8).

◆ 2.2.3 120/240V SINGLE PHASE 30A LOCKING TYPE RECEPTACLE

Cord sets used with this receptacle should be rated at least 30 AC amperes at 250 volts (or greater), (see Figure 2.6 on page 8).

At this receptacle, do not connect loads of more than 30 amps at 240 volts.

◆ 2.2.4 CORD SETS - 120 VOLTS GFCI DUPLEX RECEPTACLES

—▲ CAUTION ▲—

▲ CAUTION!: DO NOT attempt to connect any 3-phase loads to the receptacles or terminal compression lugs.

The generator is equipped with a 120 volt ground fault interrupter (GFCI) duplex receptacle on the generator receptacle panel (see Figure 2.6 on page 8). See “Ground Fault Protection” on Page 12. Each outlet consists of a “pair” of receptacles, with each pair protected against overload by a 15-amp, push-to-reset type circuit breaker. Thus, you may use each receptacle pair to power 120 volts, 60 Hz, AC electrical loads requiring up to 15 AC amperes of current or up to 1800 watts (1.8 kW) of electrical power.

◆ 2.2.5 AUXILIARY SUPPLY

A male 3 pin auxiliary supply connector is provided on the connection panel to supply utility power to the unit for battery - charging and heating. A 10A fused supply may be connected here for standby unattended use (see Figure 2.6 on page 8).

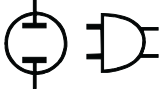

◆ **2.2.6 BATTERY CHARGER (NOT SHOWN)**

A 2.5 amp battery charger is provided in the control panel to trickle charge the batteries if the unit is left unattended. It must be hooked up to AC power.

◆ **2.2.7 ENGINE HEATER (NOT SHOWN)**

A 500W engine block heater is provided for easy starting of the unit in unattended operation.

◆ **2.2.8 REMOTE START**

The remote start functions when the unit is in AUTO and hooked up to a GTS automatic transfer switch to crank and start the generator when the utility source voltage drops below a preset level.

◆ **2.2.9 REMOTE ALARM SIGNAL**

Four customer remote signals are provided as follows:

- Contact “B” is for Low Fuel sensing and is normally open until low fuel occurs.
- Contact “C” is for monitoring unit when not in AUTO. Contact is normally closed when in OFF or MANUAL.
- Contact “E” is ground. The male connector is supplied for customer to wire up.
- Contact “F” monitors generator output. Contact is normally closed when generator output occurs.

3.1 PREPARATION BEFORE USE



CAUTION: Prior to initially starting the generator, you must properly prepare it for use. Any attempt to crank or start the engine before it has been properly serviced with the recommended oil may result in an engine failure. Also, engine coolant level must be checked and replenished if necessary.

◆ **3.1.1 ENGINE LUBRICATION**

Check engine crankcase oil level prior to use and add oil to the proper level. See “Maintenance” section for recommendations.

◆ **3.1.2 ENGINE COOLANT**

Check engine coolant level and add the recommended coolant mixture as required. Refer to “Maintenance” section.

◆ **3.1.3 FUEL**

Fill the 49-gallon base-mounted fuel tank with the correct recommended diesel engine fuel. See “Maintenance” section.

Figure 2.6 — Connection Panel

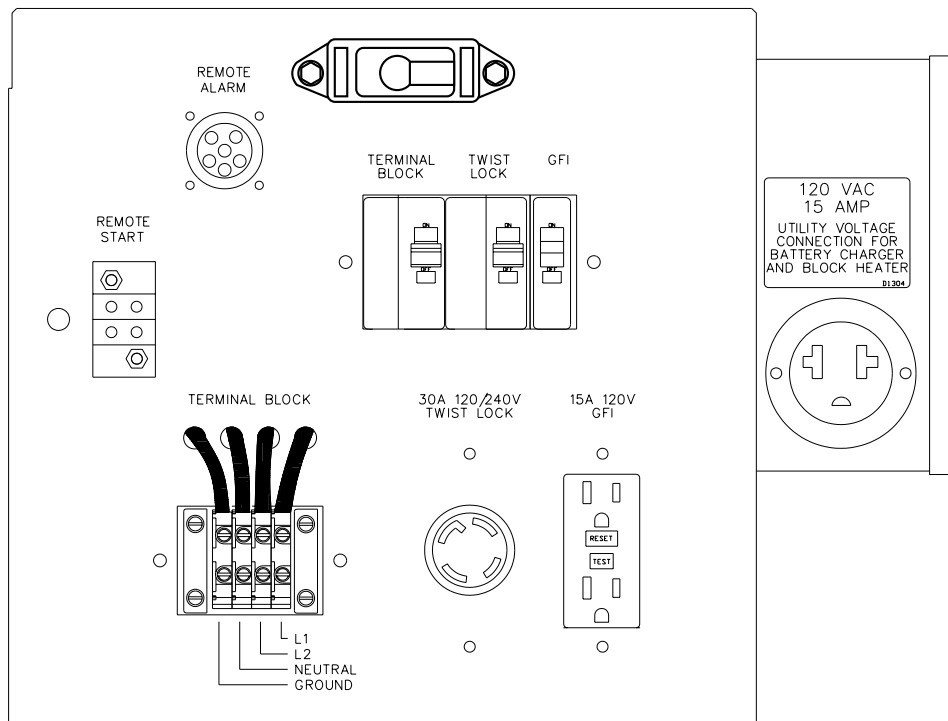

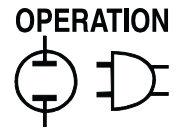

NOTE:

If the unit has been idle for a long period of time or if fuel lines or fuel system components have been removed and re-installed, the fuel system may require bleeding to remove air from the system. Air in the fuel system causes hard starting and rough engine operation. All fuel system lines must be installed and must be tight. A loose line may show no sign of leakage, but may draw air into the system.

3.2 OPERATING INSTRUCTIONS

◆ 3.2.1 BEFORE STARTING

- Prior to starting the engine, make sure the engine-generator has been properly prepared for operation as outlined in PREPARATION BEFORE USE .
- Check that the Voltage Adjust Dial is adjusted for the proper voltage that your loads require.

◆ 3.2.2 STARTING THE ENGINE

- Be sure no loads are connected to the receptacles or the compression lugs.
- When engine starts and runs at rated Hz, release the start switch to the “Run” position.
- Let the engine stabilize and warm up for a few minutes. Then connect and turn on the desired electrical loads.

NOTE:

If any monitored shutdown occurs, you cannot restart the engine until you reset the controls. To reset the engine control, set the Auto/Off/Manual switch to OFF.

◆ 3.2.3 SHUT DOWN

- Disconnect all electrical loads, or turn all loads OFF.
- Let the engine run at no-load for a few minutes to stabilize internal engine temperatures.
- On the generator control console, set the Start/Stop switch to “Stop”. Wait for the engine to come to complete stop.

3.3 APPLYING THE LOAD

Instructions in this section assume you have started the generator engine and are ready to connect electrical loads to the generator receptacles (not the main terminal).

- Let the engine warm up a few minutes before applying the load.
- To connect a load, insert a connector plug into the proper receptacle on the generator.
 - Loads rated 120/240 volts, single-phase must be connected only to the “120/240V, single-phase” receptacles.
- Do not exceed rated amperage capacity of receptacles.
- Do not exceed the rated wattage/amperage capacity of the generator.



CAUTION! Make electrical connections to main terminal block compression type terminals prior to starting engine.

3.4 ENGINE CONTROL OPERATION

The DC control circuit board controls engine start up, operation and shut down. The circuit board senses the engine is running by means of a magnetic speed sensor.

◆ 3.4.1 CRANKING AND START UP

- When engine is cranked, the starter cuts out when the generator reaches about 500 rpm.
- Following the starter cut out, a 5-second time delay permits engine oil pressure to build.
- If any one or more of the engine protective shutdown devices detects an engine fault, engine shuts down and the Fault Indicator Lamp goes ON.

◆ 3.4.2 AFTER A SHUTDOWN FAILURE

- Starting is disabled after a fault shut down until the engine control is reset.
- To reset the engine control, set the Auto/Off/Manual switch to OFF.

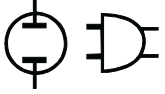

3.5 GENERATOR METER AND CONTROL PANEL

Meter and control panel components are as follows (Figure 3.1):

◆ 3.5.1 PANEL LIGHT SWITCH

This switch controls both panel lights. In the “On” position these lights will function. The “Off” position is used to insure battery is not drained when lights are not needed and during travel or storage.

◆ 3.5.2 AC AMMETER

Indicates current draw of the applied electrical loads in amperes. Rated maximum continuous load current should be kept within the limits of the rated wattage capacity of the unit. The ammeter functions only when voltage and Current/Circuit Selector switch is in position 1 or 2.

◆ 3.5.3 PANEL LIGHTS

One panel light is located on the meter and control panel while another is located on the connection panel. Each light comes on when the access door to its individual panel is opened.

NOTE:

The panel light switch must be in the “On” position for panel lights to function.

◆ 3.5.4 FREQUENCY METER

- Indicates generator AC output frequency in “Hertz” (cycles per second).
- Frequency at no-load should be about 61-63 Hz.
- With full rated wattage/ampereage load applied to the generator, frequency should not droop below about 58 Hz.

◆ 3.5.5 VOLTAGE ADJUST POTENTIOMETER

- Permits you to “fine adjust” generator AC output voltage, within a range of $\pm 5\%$.
- Turn the knob clockwise to increase voltage, counterclockwise to decrease voltage.



⚠ Voltage adjust dial affects all receptacles at all times.

◆ 3.5.6 VOLTAGE & CURRENT/CIRCUIT SELECTOR SWITCH

- Set switch to Position 1 to read L1 to Neutral output on panel AC voltmeter and ammeter.
- Set switch to Position 2 to read L2 to Neutral output on panel AC voltmeter and ammeter.
- Set switch to Position 3 to read line L1 to L2 resultant voltage on AC voltmeter.
- Position “O” is “OFF”.

Figure 3.1 — Meter and Control Panel

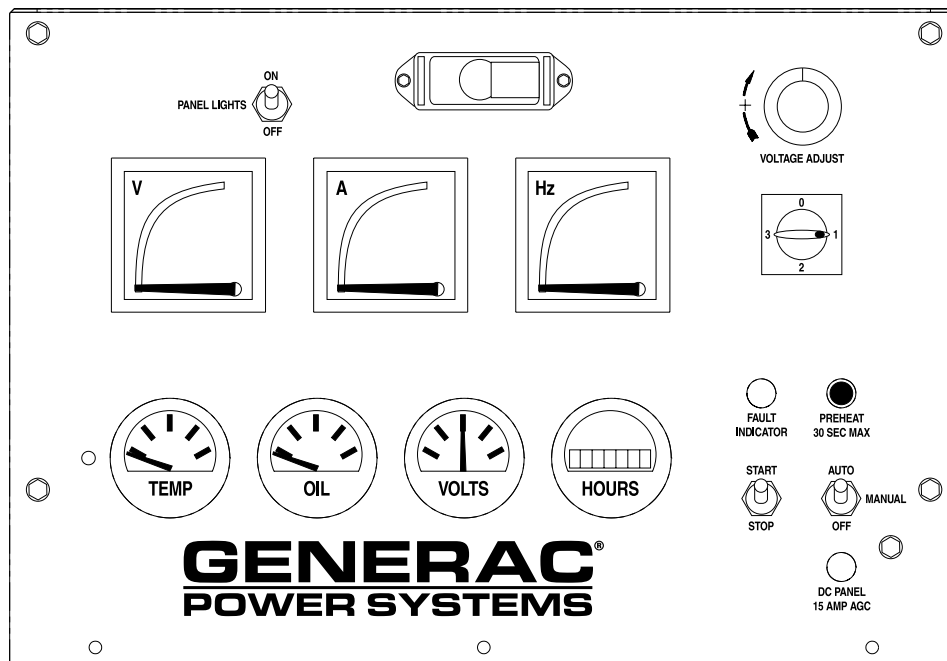

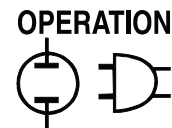

◆ 3.5.7 FAULT INDICATOR LAMP

Engine shuts down automatically and this lamp lights up when one or more of the following engine faults occurs:

- High coolant temperature (above 256° F).
- Low oil pressure (below 15 psi).
- Overspeed (above 2250 rpm or 74 Hz).
- Low coolant level.

◆ 3.5.8 PREHEAT BUTTON

Each engine cylinder has a glow plug. When you press the preheat button, it heats the engine cylinders for easier starts in cold weather.

- To turn the glow plugs on and heat the cylinder, press the Preheat Button on.
- Push button in and hold for about 15 seconds. **DO NOT EXCEED 30 SECONDS PREHEAT TIME.**
- Preheating is generally not required when starting a warm engine.

◆ 3.5.9 START/STOP SWITCH

To crank and start the engine, hold the Start/Stop switch to "Start". When engine starts and runs at rated Hz, release the switch to its center position. To shut engine down, set the switch to the "Off" position.

◆ 3.5.10 AUTO/OFF/MANUAL SWITCH

The Auto/Off/Manual switch allows the user to select automatic start mode for unattended operation or manual mode for normal local operation. In the automatic position, the generator will be started automatically when an external contact is closed between the terminals 178 - 183 on the connection panel.

◆ 3.5.11 15 AMP FUSE (DC CONTROL)

- Fuse protects the DC control circuit's in the meter and control panel against damaging electrical overloads.
- If the fuse has blown due to an overload, the engine will not crank or start.
- Should fuse replacement become necessary, use only an identical 15 amp replacement fuse.

◆ 3.5.12 HOURMETER

- Indicates engine-generator operating time, in hours and tenths of hours.
- Use the hourmeter to determine checks for periodic maintenance schedule (see "Maintenance" section).

◆ 3.5.13 DC VOLTMETER

- Indicates terminal voltage of battery.
- Battery voltage should be above 12V.
- When the unit is running or the utility powered charger is operating the voltage should rise to about 13.5V.

◆ 3.5.14 OIL PRESSURE GAUGE

- Indicates engine oil pressure.
- After warm up, oil pressure should be about 29-71 psi. Actual oil pressure reading may vary depending on oil temperature, oil viscosity, condition of engine and other factors.
- Should engine oil pressure drop below a preset level, it will shut down automatically.

◆ 3.5.15 COOLANT TEMPERATURE GAUGE

Indicates temperature of engine coolant.

During operation, coolant temperature should be about 180° to 200°F.

- Actual temperature reading depends on ambient temperature, applied load, condition of cooling system.
- If coolant temperature exceeds about 256°F, fault indicator light comes on and engine shuts down automatically.

◆ 3.5.16 AC VOLTMETER

Displays output voltage of unit. Use Voltage & Current/Circuit selector switch to select the desired circuit to be displayed.

3.6 ENGINE PROTECTIVE SHUTDOWN DEVICES

The generator engine has several protective devices mounted on it. The devices are designed to initiate an automatic shutdown in the event of low oil pressure, high coolant temperature, overspeed, and low coolant level (Figure 3.2). Such devices operate in conjunction with a DC control circuit board in the generator control panel. That circuit board controls engine cranking, start up, operating and shut down.

◆ 3.6.1 LOW OIL PRESSURE SWITCH

This switch has a normally-closed contact which is held open by engine oil pressure.

Should engine oil pressure drop below about 15 psi, switch contact closes, engine shuts down, and Fault Indicator Lamp goes ON.

◆ 3.6.2 HIGH COOLANT TEMPERATURE SWITCH

This normally open thermostatic switch has a sensing tip immersed in the engine coolant.

Should the coolant temperature exceed about 221°F (105°C), switch contact closes, engine shuts down, and Fault Indicator Lamp goes ON.

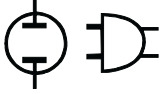
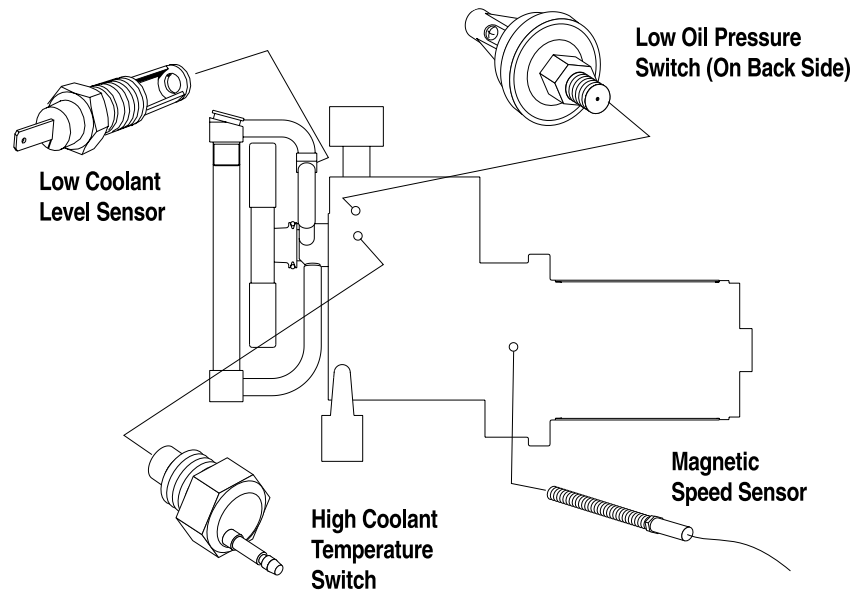

Figure 3.2 — Engine Protective Shutdown Devices



◆ 3.6.3 OVERSPEED

The DC control circuit board (inside control panel) senses engine speed from a magnetic pickup positioned over the flywheel teeth

Should generator speed exceed about 2250 rpm, circuit board action initiates an automatic shutdown and the Fault Indicator Lamp goes ON.

◆ 3.6.4 LOW COOLANT LEVEL

The unit is equipped with a low coolant level sensor which will cause a shut down if the engine coolant level drops below a safe level.

◆ 3.6.5 ENGINE STARTUP

- The DC control circuit board controls startup by sensing when the engine is running with a magnetic speed sensor.
- When engine is cranked, the starter cuts out when the generator reaches about 500 rpm.
- Following the starter cut out a 5-second time delay permits engine oil pressure to build.

3.7 GROUNDING THE GENERATOR

The National Electric Code (NEC) requires that the frame and external electrically conductive parts of the generator be properly connected to an approved earth ground. Local electrical codes may also require that you ground the unit. Consult with a local electrician for grounding requirements in your area.

Grounding helps prevent dangerous electrical shock if a ground fault exists in the generator or connected electrical devices. Grounding also helps dissipate static electricity that often builds up in ungrounded devices. Static electricity alone can cause very painful shock and may cause one to believe that a shorted condition exists in equipment.

3.8 GROUND FAULT PROTECTION

The generator is equipped with 120 volt, 15 amp Ground Fault Circuit Interrupters (GFCIs). These devices meet standards with applicable federal, state and local codes.

The GFCI protects you against electrical shock that may be caused if your body becomes a path through which electricity travels to reach ground. This could happen if you touch an appliance or cord that is “live.” You don’t even have to be on the ground, you could be touching plumbing or other material that leads to ground.

When protected by a GFCI, a person will still feel a shock, but the GFCI should cut it off quickly enough so a person in normal health should not have a serious electrical injury (Infants and very small children could still be affected).

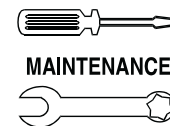

WARNING

WARNING! THE GFCI WILL NOT PROTECT YOU AGAINST THE FOLLOWING SITUATIONS: (1) LINE-TO-LINE SHOCKS (like the kind you get by touching metal in both straight slots of an outlet); (2) CURRENT OVERLOADS OR LINE-TO-LINE SHORT CIRCUITS. THE FUSE OR CIRCUIT BREAKER AT THE DISTRIBUTION PANEL MUST PROVIDE SUCH PROTECTION.

3.8.1 TESTING THE GFCI

Test your GFCI outlets every month. Follow these instructions:

1. Push the black TEST button. Red RESET button should pop out from inner surface, which should allow no power to reach the outlet. Use a test lamp in each outlet.

CAUTION

CAUTION! If RESET button does not pop out or test lamp remains lit when RESET button does pop out, DO NOT USE ANY OUTLETS ON THE CIRCUIT. CALL A QUALIFIED ELECTRICIAN.

2. If the GFCI tests good, restore power by pressing the RED RESET button. THE RESET BUTTON MUST BE PUSHED FIRMLY AND FULLY INTO PLACE UNTIL IT LOCKS AND REMAINS IN THAT POSITION. IF THE GFCI DOES NOT RESET PROPERLY, DO NOT USE THE OUTLET — CALL A QUALIFIED ELECTRICIAN. Test lamp should go ON.
3. If the GFCI trips by itself at any time during or after installation, reset and perform steps 1 and 2. IF RESET BUTTON DOES NOT POP OUT WHEN TEST BUTTON IS PRESSED, DO NOT USE THE OUTLET. CALL A QUALIFIED ELECTRICIAN.

3.9 OPERATION IN ICE OR SNOW

If the generator has been exposed to freezing rain or snow, be sure to inspect the air outlet areas in the compartment. Do not operate the unit if snow or ice have blocked or obstructed the air openings.

The generator is equipped with a “pusher” type cooling fan. This type of cooling fan draws air into the generator, then expels the air outward through the engine radiator. If cooling air flow is obstructed, the engine-generator may overheat.

4.1 MAINTENANCE

4.1.1 25 HOUR BREAK-IN PERIOD

The first 25 hours of operation is the break-in period for the towable generator. Correctly breaking in the generator is essential to minimize oil consumption and maximize engine performance. During the break-in period, observe the following rules.

1. Run the generator at various electrical loads for the first 25 hours of operation, to help seat engine piston rings properly.
2. For the next 75 operating hours, avoid light electrical loads.

During this period, load the unit at 50% or more of its rated capacity (4000 watts or more).

Repeated light electrical loads during break-in period can cause improper seating of engine piston rings, resulting in blowby and high oil consumption.

3. Check engine crankcase oil level frequently during the break-in period. It is normal for oil consumption to be high during this period.
4. After the 25 hour break-in period is completed, perform the tasks recommended under “25 Hour Checkup”.

4.1.2 25 HOUR CHECK UP

Following the first 25 hours of operation, contact an authorized service facility for the following maintenance. The generator owner is responsible for all charges.

Change engine crankcase oil and filter.

Check all fluid levels (engine oil, engine coolant, fuel, battery electrolyte fluid).

Inspect cooling system hoses for deterioration and leaks, all hose clamps for tightness and security.

Check fuel system lines for leaks, tightness, condition.

Check fuel injection timing.

Check/adjust engine governed speed (frequency).

Inspect engine belts for condition, proper tension.

Check for correct AC voltage output.

Check all generator receptacles and circuit breakers for condition, proper operation.

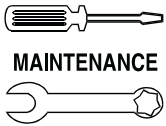

MAINTENANCE

4.2 CHECKING FLUID LEVELS

◆ 4.2.1 ENGINE CRANKCASE OIL

After the 25 hour break-in period, check engine oil every 8 hours of operation, or at least once daily before using. Check the oil level as follows:

1. When checking oil level, the generator should be sitting on a level surface.
2. Always check oil level BEFORE starting the engine, or wait at least 30 minutes after the engine is shut down.
3. Avoid mixing different brands or different types of oil.
4. Remove oil dipstick, wipe clean and fully reinstall into dipstick tube (Figure 4.1).
5. Again remove dipstick and observe oil level. Oil level must be between FULL and ADD marks on the dipstick.
6. If oil level is below ADD mark, remove oil fill cap. Add the recommended oil to bring oil level up to the FULL mark on dipstick.

Do NOT overfill.

See “Engine Oil” for recommended oil.

Figure 4.1 — Engine Oil Servicing Points

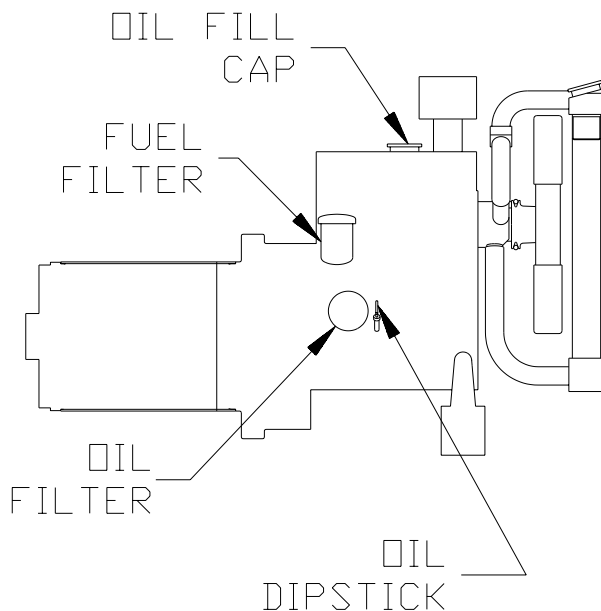

◆ 4.2.2 ENGINE COOLANT

Check coolant level in coolant recovery bottle at least once daily or prior to use.

Periodically remove radiator cap and check coolant level in radiator to see if the coolant recovery system is working properly (Figure 4.2).

Figure 4.2 — Radiator Cap and Coolant Recovery

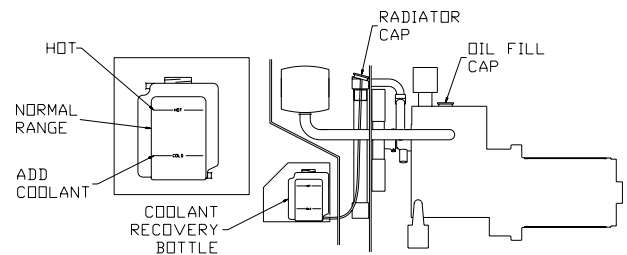

Coolant must be at top of radiator filler neck.

If coolant level in radiator is low, inspect pressure cap gasket for damage. Replace cap if necessary.

If required, you can have the radiator pressure cap tested at an automotive service facility.

Inspect cooling system for leaks.



WARNING: DO NOT REMOVE RADIATOR PRESSURE CAP WHILE ENGINE COOLANT IS HOT. THE COOLANT MAY DISCHARGE VIOLENTLY, RESULTING IN SERIOUS BURNS FROM BOILING LIQUID OR STEAM.

◆ 4.2.3 FUEL

Check fuel quantity at least once daily (every eight hours) and prior to use. The base-mounted fuel tank is equipped with a float operated fuel level gauge. Fill tank when level is between half full and 1/4 full. To fill, remove fill cap and fill tank with recommended diesel fuel (see Figure 4.3). DO NOT OVERFILL but allow room at top of tank for fuel expansion. A fuel level sensor is also provided for remote alarm monitoring.

IMPORTANT: NEVER PERMIT THE ENGINE TO RUN OUT OF FUEL. IF ENGINE RUNS OUT OF FUEL OR IF FUEL LEVEL IN TANK DROPS TOO LOW, AIR WILL ENTER FUEL SYSTEM LINES AND CAUSE SERIOUS PROBLEMS, SUCH AS HARD STARTING AND ROUGH, ERRATIC OPERATION. YOU MUST BLEED THE ENGINE FUEL SYSTEM WHEN IT RUNS OUT OF FUEL.

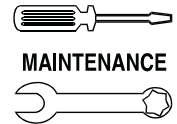
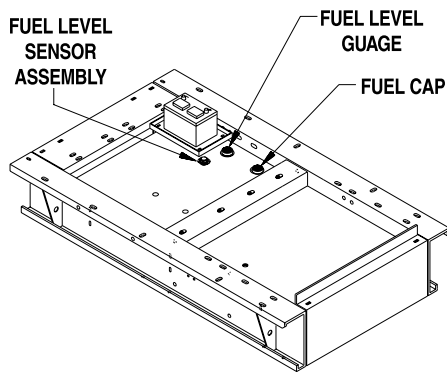

Figure 4.3 — Fuel Fill Cap and Fuel Level Gauge



◆ 4.2.4 BATTERY ELECTROLYTE FLUID

- Remove the battery vent caps and check level of electrolyte fluid in all battery cells.
- Fluid should cover tops of separators in all cells.
- If necessary to replenish fluid, use **DISTILLED WATER** only. Do **NOT** use tap water in battery.

— ⚠ WARNING ⚠ —

⚠ WARNING: BATTERY FLUID IS AN EXTREMELY CAUSTIC SULFURIC ACID SOLUTION THAT CAN CAUSE SEVERE BURNS OR DAMAGE TO EQUIPMENT AND/OR PROPERTY. DO NOT PERMIT FLUID TO CONTACT EYES, SKIN, CLOTHING, PAINTED SURFACES, WIRING INSULATION, ETC. IF YOU SPILL FLUID, FLUSH THE AFFECTED AREA WITH CLEAR WATER IMMEDIATELY. WHEN HANDLING ANY BATTERY, WEAR PROTECTIVE GOGGLES, RUBBER GLOVES AND APRON.

⚠ WARNING: STORAGE BATTERIES GIVE OFF EXPLOSIVE HYDROGEN GAS. THIS GAS CAN FORM AN EXPLOSIVE MIXTURE AROUND THE BATTERY FOR SEVERAL HOURS. DO NOT PERMIT SMOKING, OPEN FLAMES, SPARKS OR ANY OTHER SOURCE OF HEAT NEAR THE BATTERY. THE SLIGHTEST SPARK CAN IGNITE THE GAS AND CAUSE AN EXPLOSION, WITH POSSIBLE RESULTANT BLINDNESS OR INJURY. NEVER DISCONNECT ANY BATTERY CABLES WHILE ENGINE IS RUNNING. THE RESULTANT SPARK CAN CAUSE AN EXPLOSION.

4.3 ENGINE OIL

Use a high quality detergent oil having American Petroleum Institute (API) classification “For Service CC” and with a Society of Automotive Engineers (SAE) viscosity rating, depending on the prevailing ambient temperatures anticipated before the next oil change.

About 3.7 U.S. quarts of oil are required with an oil filter change.

4.4 FUEL REQUIREMENTS

Recommended is clean, fresh No. 2D diesel fuel with a minimum Cetane number of 40. It must also conform to American Society of Testing and Materials (ASTM) specifications. The fuel should be stored in sealed containers which have low point drains that permit you to drain water from it periodically. Never use any dirty or contaminated fuel.

4.5 ENGINE COOLANT

Recommended is a mixture of half low silicate, ethylene glycol base anti-freeze and soft water. Never mix different types or brands of anti-freeze. If desired, a high quality rust inhibitor may be added to the recommended mixture.

— ⚠ CAUTION ⚠ —

⚠ CAUTION: Use only low silicate, ethylene glycol base anti-freeze. Use soft water only. Do **NOT** add any chromate base rust inhibitor. Do **NOT** use a higher ratio of anti-freeze than the recommended 50%. Failure to follow this rule can cause chromium hydroxide, or “green slime” to form in the cooling system, which could lower the heat transfer rate and cause engine overheating problems. Generac also recommends that you do **NOT** use soluble oil rust inhibitors.

4.6 OWNER/OPERATOR MAINTENANCE

1. Check the engine oil level once daily.
2. Check coolant level in coolant recovery bottle at least once daily (prior to use). Maintain bottle about half full with the recommended 50-50 mixture.
3. At least once weekly check coolant level in radiator. See “Checking Fluid Levels” on page 14.
4. Inspect cooling system at least once each month or every 100 operating hours, whichever occurs first.
 - Check hoses for damage, deterioration, leaks, etc.
 - Replace any damage or defective hoses or fittings.
5. Inspect the entire engine-generator at least once each week.
 - Look for obvious damage, loose or missing fasteners, fuel or oil leakage, etc.
 - Correct any discrepancies found.
6. Inspect all of the exhaust system at least once a month or every 100 operating hours, whichever comes first.
 - Check muffler, exhaust pipes, fittings, clamps, etc. for leaks, damage, deterioration, tightness, etc.

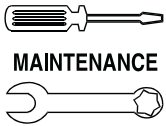

- When the unit is running, listen for unusual noise levels that might indicate exhaust leakage.
7. Inspect the battery at least once each week.
 - Check battery fluid level, add distilled water if required. Do NOT use tap water.
 - Check battery cables and battery posts for cleanliness, corrosion. Clean as needed.
 8. Check trailer tires for proper inflation, damage, excessive wear. Recommended inflation pressure is 50 psi. Do NOT exceed 55 psi air pressure.

4.7 CLEANING THE GENERATOR

The towable generator should be kept as clean and as dry as possible. Exterior surfaces of the generator compartment and trailer may be cleaned with a mild detergent and water. If desired, a high quality automotive type wax may be applied to exterior surfaces, to prevent rust and corrosion.

The generator compartment interior and the engine generator itself should be kept clean and free of fuel, oil, coolant, water, etc.

Store the unit in a clean, dry area where temperatures are fairly constant.

4.8 ADJUSTMENTS

Adjusting the engine governed speed and fuel injection timing are not “do-it-yourself” tasks. If you think the engine governor needs adjusting, contact your nearby authorized service facility. That facility will have the proper equipment, training and experience to complete all necessary adjustments.

NOTE:

Engine speed and AC frequency are directly proportional. The unit supplies its rated voltage (240 volts at 60 Hz) at 1800 rpm. If engine governed speed is incorrect, AC output frequency and voltage will be affected.

4.9 GENERATOR ROTOR BEARING

The generator rotor is attached to the engine drive shaft at one end. The opposite end of the rotor rides in a prelubricated and sealed ball bearing that requires no additional lubrication for the life of the bearing.

4.10 FREEZING TEMPERATURE OPERATION

The engine cooling system was factory serviced with a mixture of half ethylene glycol base anti-freeze and half soft water. When adding coolant to the radiator or to the coolant recovery bottle, use only the recommended mixture. If you added the recommended mixture consistently, the unit is adequately protected against freezing temperatures.



CAUTION: Increasing the ratio of anti-freeze in the coolant mixture is not recommended. Use only the recommended 50-50 mixture. If the ratio of anti-freeze in the mixture is raised above 60%, you may have problems with overheating. Also, do not use water with high alkali content. Use only soft water.

It is the operator's responsibility to perform all safety checks; to make sure that all maintenance is performed for safe operation; and to have the equipment checked by an authorized service facility periodically. Normal maintenance service and replacement parts are the responsibility of the owner/operator and, as such, are not considered defects in workmanship or material within terms of the warranty. Individual operating habits and usage contribute to the need for maintenance service.

Proper maintenance and care for your towable generator assures you a minimum number of problems and keeps your overall operating expenses low.

4.11 EFFECTS OF MOISTURE AND DIRT

Allowing dirt and moisture to accumulate on electrical windings have an adverse effect on insulation resistance.

When you allow moisture to remain in contact with generator windings, the moisture is retained in voids and cracks in the insulation. This reduces insulation winding resistance.

Dirt makes the problem of moisture retention worse. It tends to hold moisture into contact with the windings. Salt (as from sea air) will also worsen the problem, since it can absorb moisture from the air. This combination of salt and moisture makes a good electrical conductor.

Once annually have the generator stator and rotor windings tested for proper insulation resistance. Have it tested at an authorized service facility.



4.12 SERVICE FACILITY MAINTENANCE

Have an authorized service facility perform the following periodic maintenance tasks at the intervals indicated.

- A. After the first 25 hours of operation:
 - See “25 Hour Checkup” on Page 13.
 - The first 25 operating hours on a new unit are the break-in period.
- B. Every 6 months or every 250 hours of operation (whichever comes first)
 - Change engine oil and oil filter.
 - Check engine preheat circuit for proper operation.
 - Service engine fuel filters as required.
 - Check battery state of charge and condition.
 - Run engine and check for proper operation.
 - Check engine governed speed.
 - Check fuel injection timing.
 - Inspect engine fuel system.
 - Check engine v-belts for condition, proper tension.
 - Check and inspect entire AC electrical system.
 - Check for correct voltage output.
 - Inspect compartment air inlet and outlet openings.
- C. Once annually or every 500 hours of operation (whichever comes first)
 - Drain, flush, refill engine cooling system.
 - Check engine valve clearance.
 - Check fuel injectors for proper operation.
 - Retorque engine cylinder head bolts.
 - Retorque engine intake and exhaust manifold.
 - Test and inspect radiator pressure cap.
 - Pressure test cooling system and inspect for leaks.
 - Check insulation resistance of generator stator and rotor windings.

4.13 MAJOR REPAIRS

Proper and regular maintenance of the generator is needed to make sure the generator has a long and trouble-free life. Only a qualified, competent generator service technician should perform all major generator service, including installation and replacement of factory approved repair parts. Only qualified, competent diesel engine repair facilities should service the engine, using only factory approved parts.

Sections 7 and 8 of your OWNER'S MANUAL consists of WIRING DIAGRAMS, ELECTRICAL SCHEMATICS, and EXPLODED VIEWS pertaining to the standby generator and its engine, along with PARTS LISTS for the EXPLODED VIEWS. The PARTS LISTS consist of (a) an item number, (b) quantity required, (c) a part number and (d) a description of the part. The ITEM NUMBER relates to an identical number in the EXPLODED VIEW.

◆ 4.13.1 HOW TO ORDER PARTS

To order a replacement part, locate the part in the applicable EXPLODED VIEW in this manual. Provide the dealer/distributor with the following information:

- Generator BUILD NUMBER (from the unit data plate).
- Part NUMBER and DESCRIPTION (from the applicable PARTS LIST in this manual).
- The applicable exploded view DRAWING NUMBER.



5.1 TROUBLESHOOTING GUIDE

PROBLEM	CAUSE	CORRECTION
The engine will not crank.	<ol style="list-style-type: none"> 1. Fuse blown 2. Loose, corroded or defective battery cables 3. Defective starter contactor 4. Defective starter motor 5. Dead battery 6. Low oil pressure switch open from ground 	<ol style="list-style-type: none"> 1. Replace fuse. 2. Tighten, clean or replace as necessary. 3. Replace starter contactor. 4. Replace starter motor. 5. Charge or replace battery. 6. Check switch continuity to ground. If not available, remove and replace switch.
The engine cranks but will not start.	<ol style="list-style-type: none"> 1. Out of fuel 2. Defective fuel solenoid (FS) 3. Open #14 wire from engine control board 	<ol style="list-style-type: none"> 1. Replenish fuel. 2. Replace fuel solenoid. 3. Check connections and insulation of #14 wires.
The engine starts hard and runs rough.	<ol style="list-style-type: none"> 1. Air cleaner plugged or damaged 	<ol style="list-style-type: none"> 1. Check, clean or replace air cleaner.
The engine starts but shuts down immediately.	<ol style="list-style-type: none"> 1. Engine oil level low 2. Defective low oil pressure switch 3. Defective high temperature switch 4. Defective control board 	<ol style="list-style-type: none"> 1. Check oil and add oil as needed. 2. Replace pressure switch. 3. Replace temperature switch. 4. Replace control board.
The Auto/Off/Manual switch is set to OFF, but the engine continues to run.	<ol style="list-style-type: none"> 1. Defective Auto/Off/Manual switch 2. Auto/Off/Manual switch wired incorrectly 3. Defective control board 	<ol style="list-style-type: none"> 1. Replace switch. 2. Check wiring and connections. 3. Replace control board.
There is no AC output from the generator.	<ol style="list-style-type: none"> 1. Main line circuit breaker open 2. Generator internal failure 	<ol style="list-style-type: none"> 1. Reset circuit breaker to ON (closed) position. 2. Contact an Authorized Dealer.

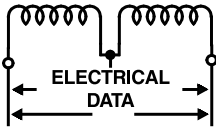

Section 7 – Electrical Data

Generac GR-8 Standby Generator

Wiring Diagram - Control Panel – Drawing No. C9257-B

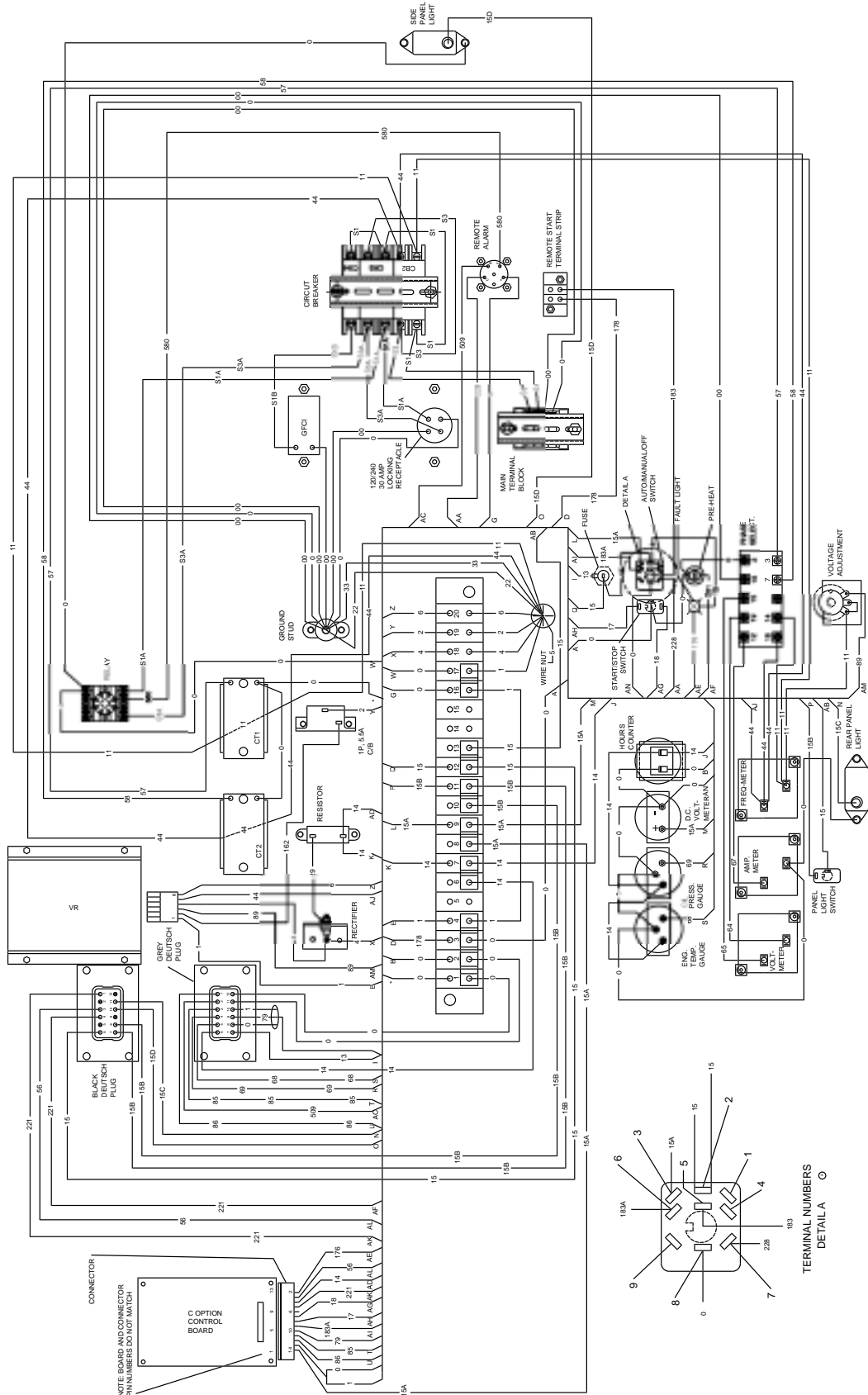

Section 7 – Electrical Data

Generac GR-8 Standby Generator

Electrical Schematic - Engine/Trailer – Drawing No. D1680

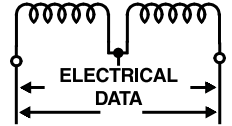

- LEGEND**
- BC- BATTERY CHARGER
 - CR- CONTACTOR RELAY
 - DCA- DC ALTERNATOR
 - DCR- DC REGULATOR
 - EH- ENGINE HEATER
 - FS- FUEL SHUTOFF
 - FP- FUEL PUMP
 - GP- GLOW PLUG
 - LDS- LOW OIL PRESS. SWITCH
 - LFS- LOW FUEL SENSOR
 - PR- PREHEAT RELAY
 - RPM- SPEED SENSOR
 - RDS- REAR DOOR SWITCH
 - SDS- SIDE DOOR SWITCH
 - SC- STARTER CONTACTOR
 - SM- STARTER MOTOR
 - SOP- SENDER OIL PRESS.
 - SWT- SENDER WATER TEMP.
 - WLS- WATER LEVEL SENSOR
 - WTS- WATER TEMP SWITCH

NOTE:
BLACK & GRAY # DESIGNATION
REFER TO 12 PIN DEUTSCH
PLUG CONNECTORS.

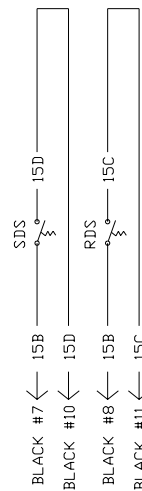
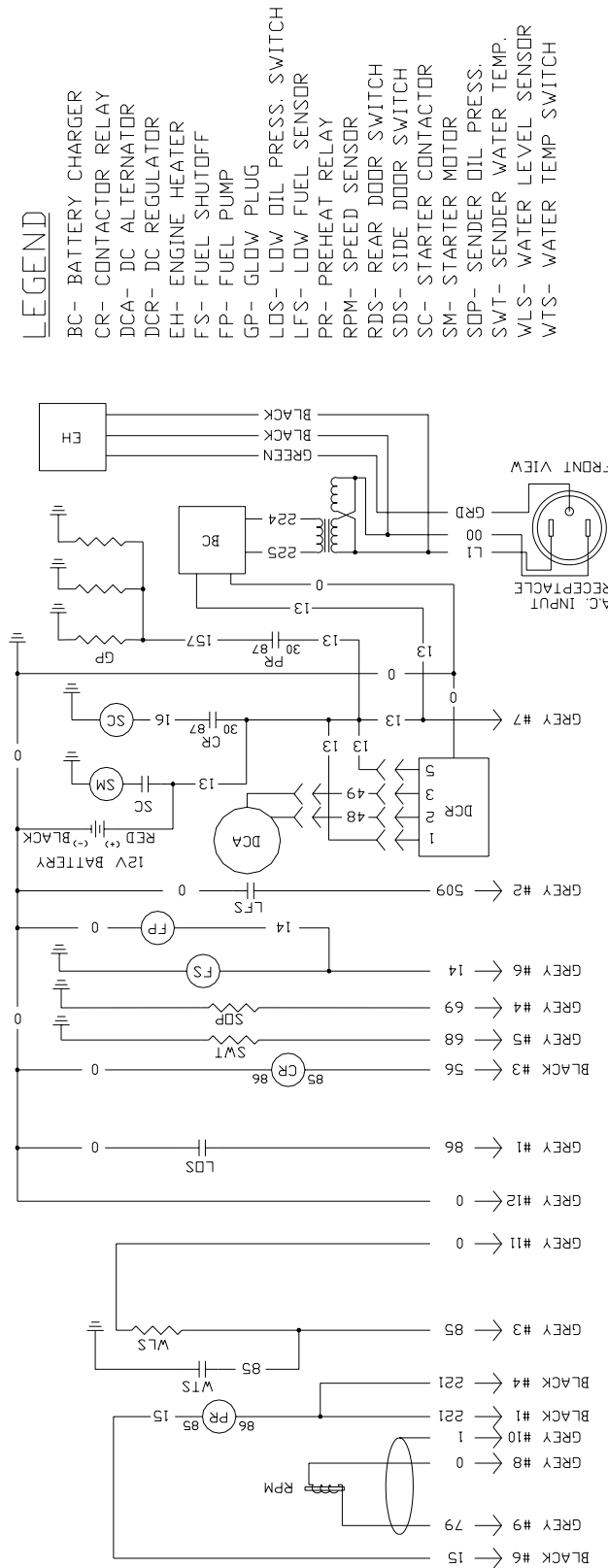

Section 7 – Electrical Data

Generac GR-8 Standby Generator

Electrical Schematic – Drawing No. C9423-B

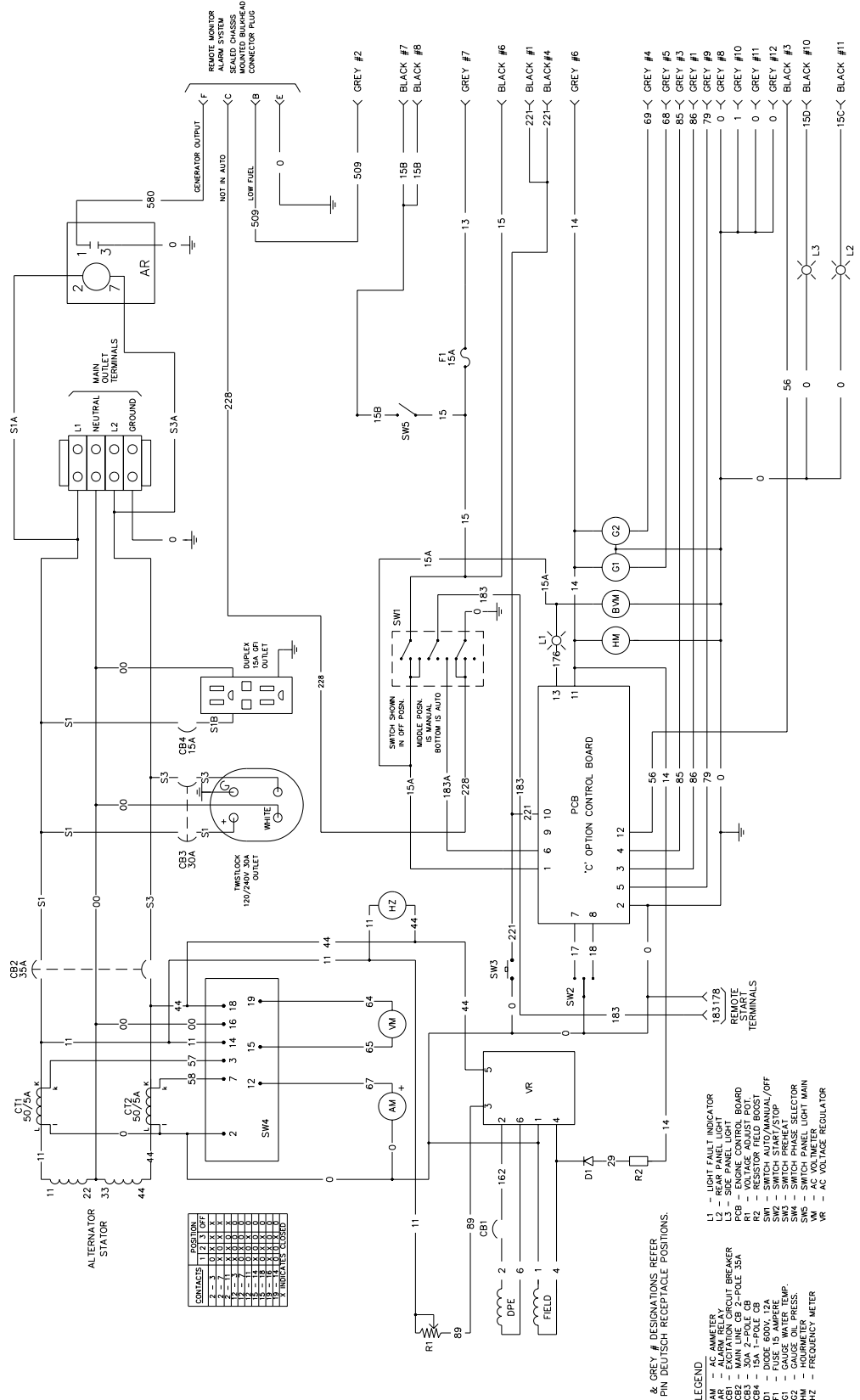
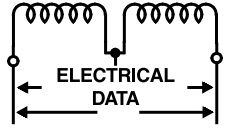

CONTACTS	POSITION
1	0
2	1
3	2
4	3
5	4
6	5
7	6
8	7
9	8
10	9
11	10
12	11
13	12
14	13
15	14
16	15
17	16
18	17
19	18
20	19
21	20
22	21
23	22
24	23
25	24
26	25
27	26
28	27
29	28
30	29
31	30
32	31
33	32
34	33
35	34
36	35
37	36
38	37
39	38
40	39
41	40
42	41
43	42
44	43
45	44
46	45
47	46
48	47
49	48
50	49
51	50
52	51
53	52
54	53
55	54
56	55
57	56
58	57
59	58
60	59
61	60
62	61
63	62
64	63
65	64
66	65
67	66
68	67
69	68
70	69
71	70
72	71
73	72
74	73
75	74
76	75
77	76
78	77
79	78
80	79
81	80
82	81
83	82
84	83
85	84
86	85
87	86
88	87
89	88
90	89
91	90
92	91
93	92
94	93
95	94
96	95
97	96
98	97
99	98
100	99
101	100
102	101
103	102
104	103
105	104
106	105
107	106
108	107
109	108
110	109
111	110
112	111
113	112
114	113
115	114
116	115
117	116
118	117
119	118
120	119
121	120
122	121
123	122
124	123
125	124
126	125
127	126
128	127
129	128
130	129
131	130
132	131
133	132
134	133
135	134
136	135
137	136
138	137
139	138
140	139
141	140
142	141
143	142
144	143
145	144
146	145
147	146
148	147
149	148
150	149
151	150
152	151
153	152
154	153
155	154
156	155
157	156
158	157
159	158
160	159
161	160
162	161
163	162
164	163
165	164
166	165
167	166
168	167
169	168
170	169
171	170
172	171
173	172
174	173
175	174
176	175
177	176
178	177
179	178
180	179
181	180
182	181
183	182
184	183
185	184
186	185
187	186
188	187
189	188
190	189
191	190
192	191
193	192
194	193
195	194
196	195
197	196
198	197
199	198
200	199

NOTE: BLACK & GREY # DESIGNATIONS REFER TO 12 PIN DEUTSCH RECEPTACLE POSITIONS.

- LEGEND**
- AM – AC AMMETER
 - AR – ALARM RELAY
 - L1 – LIGHT FAULT INDICATOR
 - L2 – SEAR PANEL LIGHT
 - PCB – ENGINE CONTROL BOARD
 - CB2 – MAIN LINE CB 2-POLE 35A
 - CB3 – 30A 2-POLE CB
 - CB4 – 30A 2-POLE 35A
 - D1 – DIODE 600V, 12A
 - F1 – FUSE 15 AMPERE
 - G2 – GAUGE OIL PRESS.
 - HM – HOURMETER
 - HW – AC VOLTAGE REGULATOR
 - HZ – FREQUENCY METER
 - M – METER
 - VR – AC VOLTAGE REGULATOR
 - SW1 – SWITCH AUTO/MANUAL/OFF
 - SW2 – SWITCH START/STOP
 - SW3 – SWITCH PHASE SELECTOR
 - SW4 – SWITCH PHASE SELECTOR
 - SW5 – SWITCH PANEL LIGHT MAIN
 - SW6 – SWITCH PANEL LIGHT MAIN
 - SW7 – AC VOLTAGE REGULATOR

Section 8 — Exploded Views and Parts Lists

Generac GR-8 Standby Generator
Trailer — Drawing No. C9362-B

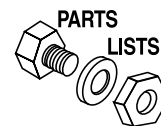

ITEM	PART NO.	QTY.	DESCRIPTION
1	A3580	1	COUPLER 8 KW TRAILER
2	A6022	1	TOWBAR ASSEMBLY
3	A5983	1	AXLE & 1/2-20 LUG NUTS
4	A3583	2	FENDER 8 KW TRAILER
5	A3908	2	WHEEL 8 KW TRAILER
6	C8990	1	BRACKET LICENCE PLATE
7	A3910A	1	WHEEL JOCKEY
8	C8989	1	LIGHT LICENSE PLATE
9	61342	2	SCREW HHC 1/2-13 X 1-1/4 G5
10	D1575	1	HARNESS WIRE ASSEMBLY TRAILER
11	A3963R	1	CHAIN SAFETY SET
12	A3964	2	LINK QUICK 5/16
13	49813	2	NUT HEX M6 -1.0 G8 YEL CHR
14	22097	2	WASHER LOCK M6-1/4
15	A4356	1	BRACKET AXLE
16	81779	1	RING SNAP EXT 2.5 X 2.313
17	A3960	4	SCREW HHC 9/16-12 X 3-3/4 G5
18	43123	4	WASHER LOCK M14
19	A6054	4	NUT 9/16-12
20	A6075	2	BRACKET FENDER
21	42568	2	SCREW HHC M6-1.0 X 20 G8.8
22	22132	4	WASHER FLAT 9/16-M14
23	28129	4	WASHER FLAT SPECIAL .281 I.D.
24	69865	4	TIE WRAP 11" BLACK
25	45771	2	NUT HEX M8-1.25
26	39253	14	SCREW HHC M8-1.25 X 20
27	55934H	1	CLAMP VINYL .62 X .406 Z
28	55934A	4	CLAMP VINYL .62 X .281 Z
29	22145	12	WASHER FLAT 5/16-M8
30	22129	14	WASHER LOCK 5/16-M8
31	51715	2	NUT HEX M4-0.7
32	22240	4	SCREW HHC 1/2-13 X 1 G5
33	23316	2	SCREW HHC 1/2-13 X 4 G5
34	22304	8	WASHER FLAT 1/2
35	22195	8	WASHER LOCK 1/2
36	22196	8	NUT HEX 1/2-13 STEEL
37	49814	4	SCREW HHC M10-1.5 X 25
38	22131	4	WASHER FLAT 3/8-M10
39	46526	4	WASH LOCK M10 X 10.2
40	45772	4	NUT HEX M10-1.5 X 8
41	78139	2	JACK STABILIZER
42	84932	2	SCREW HHC M4-0.7 X 30
43	22985	2	WASHER FLAT #6-M4
44	22264	2	WASHER LOCK #8-M4

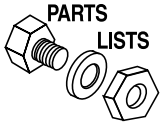

Section 8 — Exploded Views and Parts Lists

Generac GR-8 Standby Generator
Base & Tank — Drawing No. C9406-B

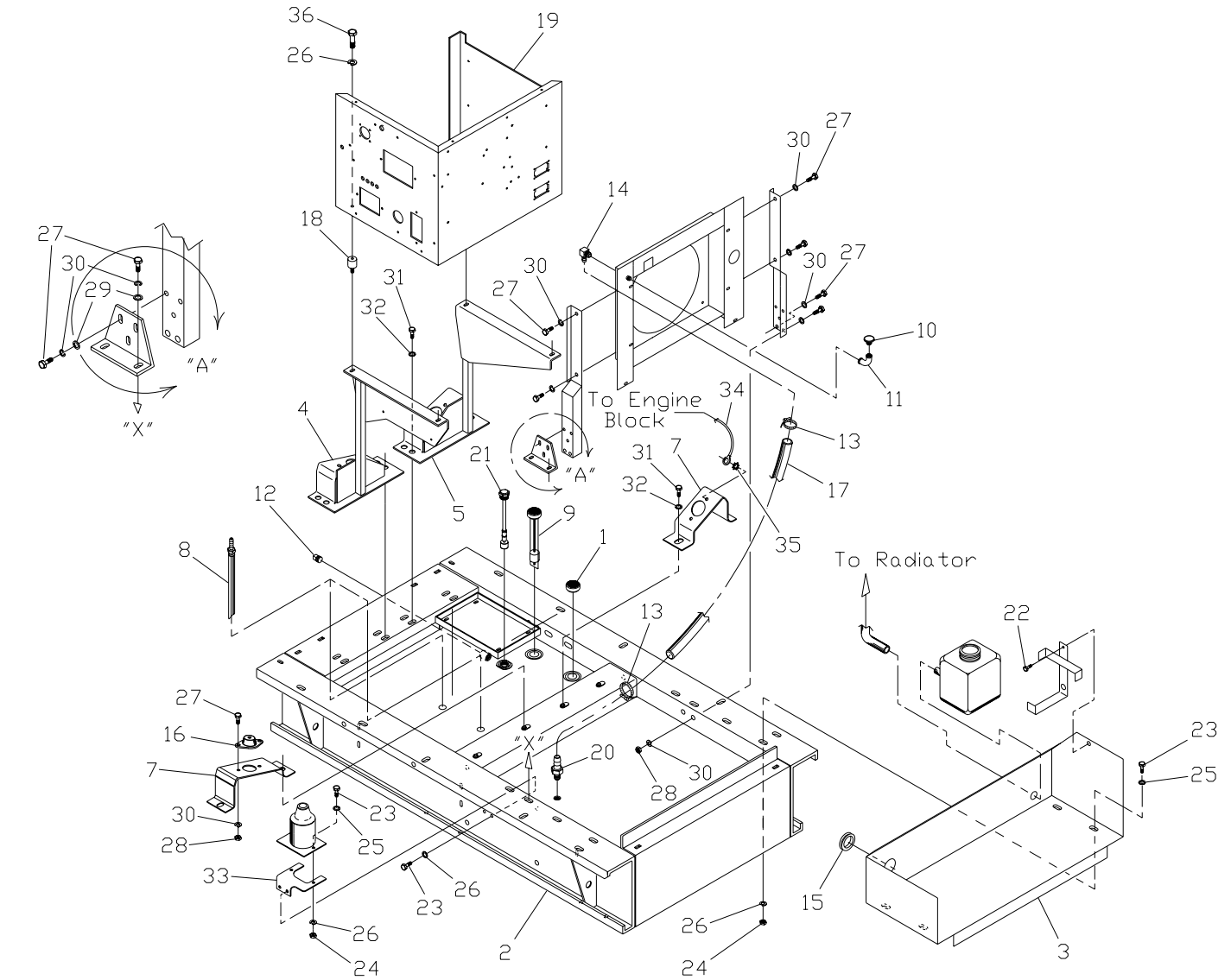

Section 8 — Exploded Views and Parts Lists

Generac GR-8 Standby Generator
Base & Tank — Drawing No. C9406-B

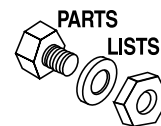

ITEM	PART NO.	QTY.	DESCRIPTION
1	A1492	1	CAP FUEL
2	A6012	1	BASE FRAME ASSEMBLY
3	C9389	1	TOOLBOX / CABLE TRAY
4	C8471	1	ALTERNATOR MOUNT ASSEMBLY RH SIDE
5	C8492	1	ALTERNATOR MOUNT ASSEMBLY LH SIDE
7	A4285	2	BRACKET ENGINE MOUNT
8	21538A	2	FUEL DIP PIPE 274MM
9	21973A	1	GUAGE FUEL LEVEL 286
10	26847	1	BREATHER
11	26924	1	ELBOW 90D STREET 3/8
12	26925	1	PLUG STD PIPE 3/8 STEEL SQ HD
13	40173	2	CLAMP HOSE #5.5 .62 - .62
14	43790	1	BARB ELBOW 3/8 X 3/8 X 1.08
15	72252	1	GROMMET 1.37 X .06 X 1.00
16	70936	4	DAMPENER VIBRATION
17	47290	2.62 FT	HOSE RES 3/8 SNGL BRD
18	40479	4	MOUNT VIBR 1.00 X 1.00 X 1/4-20
19		1	CONTROL PANEL (See Control Panel Exploded View Drawing C9469)
20	55596	1	BARB STRIGHT 3/8 X 3/8 X 1.72
21	C9370	1	SENSOR FUEL LEVEL ASSEMBLY
22	74906	1	SCREW TAPTITE M6 X 20 BP
23	42568	8	SCREW HHC M6-1.0 X 20
24	49813	6	NUT HEX M6 -1.0
25	22473	6	WASHER FLAT M6
26	22097	12	WASHER LOCK M6
27	39253	26	SCREW HHC M8-1.25 X 20
28	45771	12	NUT HEX M8-1.25
29	22145	10	WASHER FLAT M8
30	22129	26	WASHER LOCK M8
31	49814	12	SCREW HHC M10-1.5 X 25
32	46526	12	WASHER LOCK M10
33	A4160	1	BRACKET ENGINE HEATER
34	68-44114	1	WIRE ASSEMBLY - GROUND STRAP
35	22261	1	WASHER SHAKEPROOF INT 3/8
36	22507	4	SCREW HHC 1/4-20 X 1/2 G5



Section 8 – Exploded Views and Parts Lists

Generac GR-8 Standby Generator
Compartment – Drawing No. C9404

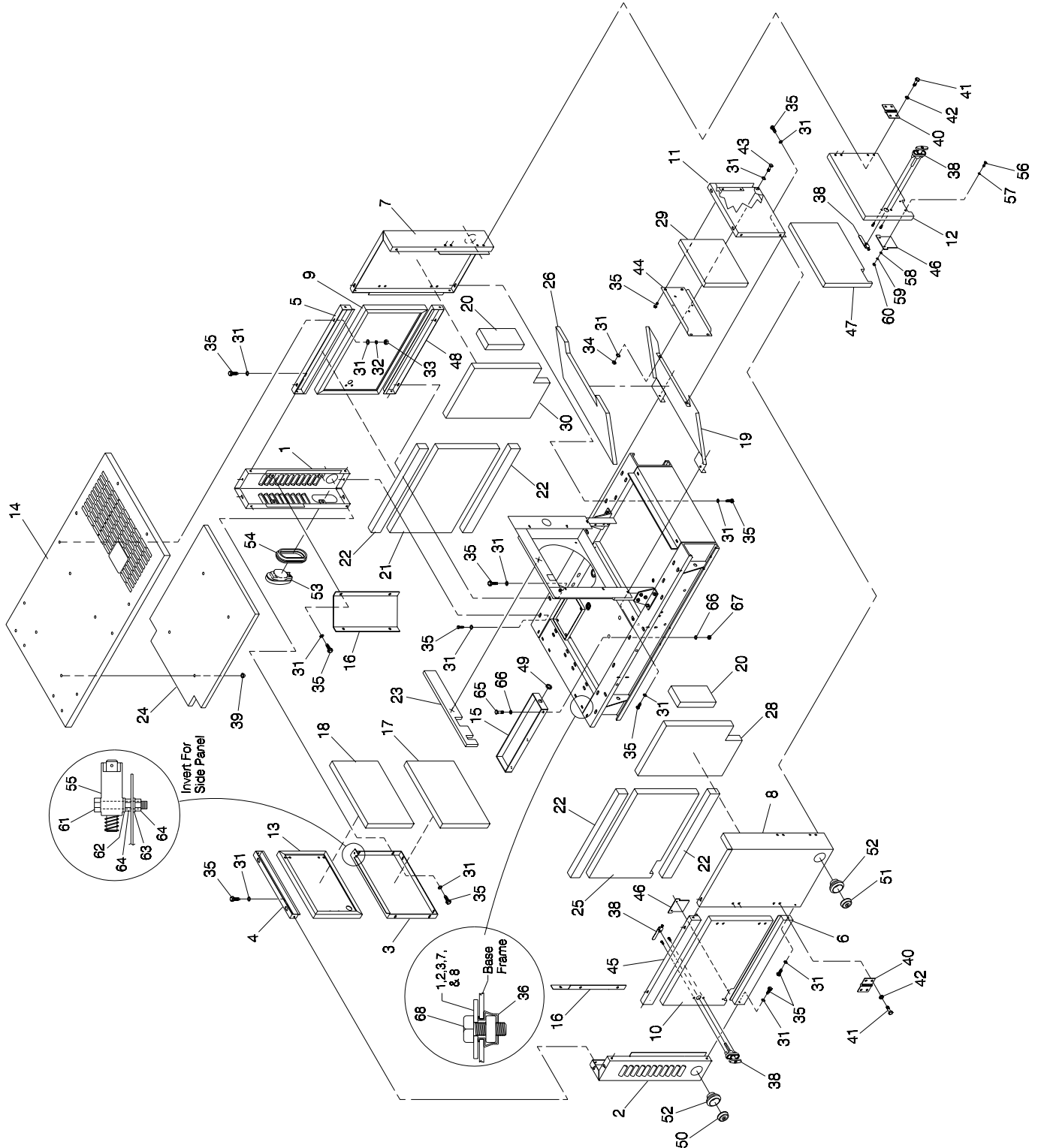

Section 8 — Exploded Views and Parts Lists

Generac GR-8 Standby Generator
Compartment — Drawing No. C9404

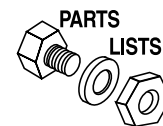

ITEM	PART NO.	QTY.	DESCRIPTION	ITEM	PART NO.	QTY.	DESCRIPTION
1	C8278	1	CORNER POST, LH. REAR	39	78115	4	WASHER, SELF LOCK/DOME
2	C8279	1	CORNER POST, RH. REAR	40	A3133A	4	HINGE, SLIP-MALE L.H.
3	C9361	1	PANEL, REAR BOTTOM		A3133B	4	HINGE, SLIP-FEMALE L.H.
4	A3444	1	PANEL, REAR TOP		A3133C	4	HINGE, SLIP-MALE R.H.
5	A3445	1	PANEL, SIDE		A3133D	4	HINGE, SLIP-FEMALE R.H.
6	C9409	1	PANEL, BOTTOM RH. SIDE	41	A3359	32	BHSCS-M6 x 16 S.S.
7	C8367	1	CORNER POST, LH. FRONT	42	A3360	32	SHAKEPROOF, INT.-M6 S.S.
8	C8366	1	CORNER POST, RH. FRONT	43	42568	2	HHCS-M6-1.0 x 20 LONG
9	A3449	1	DOOR, LH. SIDE	44	C7928	1	MUFFLER SUPPORT
10	A3450	1	DOOR, RH. SIDE	45	C9173	1	PANEL, RH. SIDE TOP
11	C7927	1	PANEL, FRONT TOP	46	C9296	2	SPLASH GUARD (DOOR)
12	C9089	1	DOOR, FRONT	47	C2755Q	1	DOOR, FRONT (INSUL.)
13	A3453	1	DOOR, REAR	48	C9411	1	PANEL, LH. SIDE BOTTOM
14	A3454	1	TOP, ROOF	49	72252	1	GROMMET
15	A3486	1	BOX, CABLE	50	C8464	2	LIGHT, 2.5" RED SIDE MARKER W/REFLEX REFLECTOR
16	A3790	2	DUCT, CORNER POST				
17	C2755A	1	PANEL, REAR BOTTOM (INSUL.)	51	C8815	2	LIGHT, 2.5" AMBER SIDE MARKER W/REFLEX REFLECTOR
18	C2755B	1	DOOR, REAR (INSUL.)				
19	C7926	1	BAFFLE, AIR	52	C8793	4	GROMMET, SIDE MARKER W/REFLEX REFLECTOR
20	C2755D	2	CORNER POST, FRONT (INSUL.)				
21	C2755E	1	DOOR, LEFT SIDE (INSUL.)	53	A9077	2	TAIL LIGHT GR-25
22	C2755F	4	PANEL, SIDE (INSUL.)	54	A9821	2	GROMMET, TAIL LIGHT GR-25
23	C2755N	1	VENTURI, TOP (INSUL.)	55	C9491	2	SWITCH, DOOR
24	C2755P	1	ROOF, TOP (INSUL.)	56	70001	4	SCREW HHC M6-1.0 X 20 SS
25	C2755T	1	DOOR, RIGHT SIDE (INSUL.)	57	27958	4	WASHER NYLON .260
26	C2755G	1	AIR DUCT, BOTTOM (INSUL.)	58	70007	4	WASHER FLAT M6 SS
28	C2755J	1	CORNER POST, FRONT SIDE RH. (INSUL.)	59	70005	4	WASH LOCK M6 SS
				60	70003	4	NUT HEX M6-1.0
29	C2755K	1	AIR DUCT, FRONT (INSUL.)	61	84932	4	SCREW HHC M4-0.7 X 30
30	C2755L	1	CORNER POST, FRONT SIDE LH. (INSUL.)	62	43180	4	WASHER FLAT M4
				63	22264	4	WASHER LOCK #8-M4
31	22473	55	WASHER FLAT M6 ZINC	64	51715	8	NUT HEX M4-0.7
32	22097	8	WASH LOCK M6	65	39253	3	SCREW HHC M8-1.25 X 20
33	22127	8	NUT HEX 1/4-20 STEEL	66	22145	6	WASHER FLAT M8 ZINC
34	52857	2	LOCK FLANGE NUT M6-1.0	67	52858	3	LOCK FLANGE NUT M8-1.25
35	74906	43	SCREW TAPTITE M6X20 BP	68	D1092	6	SERRATED FLANGE HHCS 5/16-18 X 20
36	C9500	6	SPEED NUT-5/16-18				
38	67042	4	LATCH & CAM				

Section 8 – Exploded Views and Parts Lists

**Generac GR-8 Standby Generator
Control Panel – Drawing No. C9469-B**

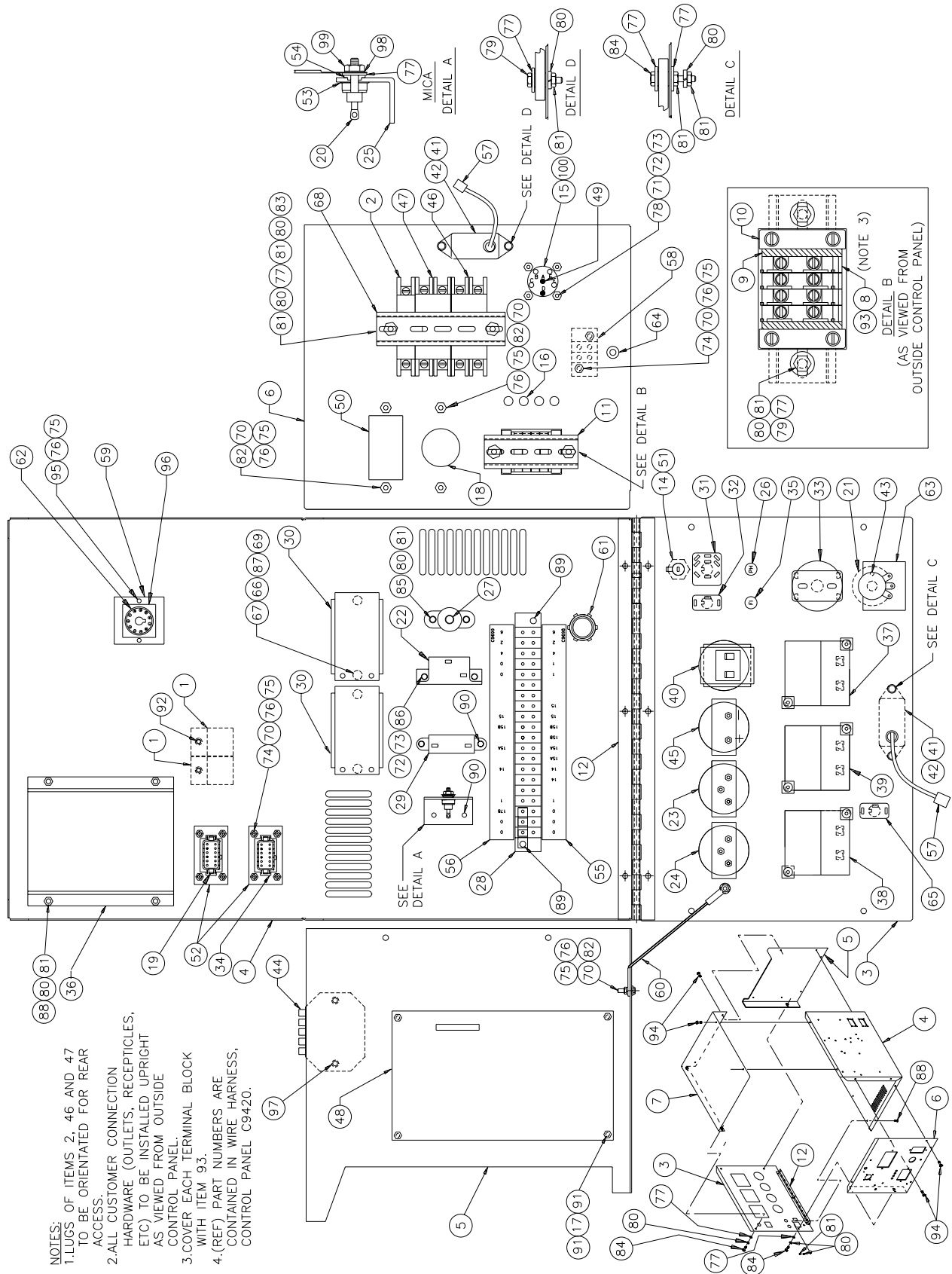

Section 8 — Exploded Views and Parts Lists

Generac GR-8 Standby Generator Control Panel — Drawing No. C9469-B

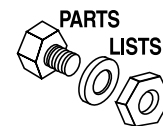

ITEM	PART NO.	QTY.	DESCRIPTION	ITEM	PART NO.	QTY.	DESCRIPTION
1	A2560	2	RELAY PNL 12VDC 50A 1POLE	52	C5141	2	CONN DEUTSCH GASKET BLKHD
2	A3288	1	CIRCT BRK 15 X 1120V	53	70370	1	WASHER MICA .203
3	C8512S	1	SCREEN FRONT PANEL	54	30468	1	WASHER STEP NYLON .20
4	C8516	1	PANEL BACK CONTROL	55	C9698	1	LABEL FRONT TERMINAL STRIP
5	C8514	1	PANEL LH SIDE CONTROL	56	C9699	1	LABEL REAR TERMINAL STRIP
6	C8515S	1	SCREEN RH SIDE PANEL	57	74129	2	LUG DIS SN-RCPT 1-T 22-18 BR
7	C8513	1	PANEL TOP CONTROL	58	48766	1	BLOCK CINCH 141 2 X 6 X 1100 V
8	A3850	4	LUG BOX BLOCK TERM	59	C3211G	1	RELAY SOCKET
9	A3851	2	BARRIER TERM BLOCK END	60	A2275	1	DOOR-STOP RAM PANEL
10	A3853	2	CLAMP END PLASTIC	61	34616	1	FITTING STRAIGHT 3/4"
11	A3854A	1	DIN RAIL, TERMINAL BLOCK	62	C3211M	1	RELAY 240VAC DPDT
12	C1914B	1	HINGE CONTROL PANEL	63	55349	1	INSULATOR
13*	C9420	1	HARNES CONTROL PANEL WIRE	64	22717A	1	GROMMET 3/8 X 1/16 X 1/4
14	22676	1	FUSE 15A X AGC15	65	28199	1	SWITCH SPST 6A TAB C-H
15	C8996	1	CONN DEUTSCH RECPT SQ FL TH GRY	66	22473	4	WASHER FLAT M6 ZINC
16	23484A	4	BUSHING SNAP SB-375-4	67	42568	4	SCREW HHC M6-1.0 X 20
17	64525	4	STANDOFF HEX 3/4	68	A3854D	1	RAIL TERMINAL BLOCK 123
18	43437	1	OUTLET 120/240 TL30A	69	49813	4	NUT HEX M6-1.0
19**	C5137	1	CONN DEUTSCH RECEPT BK/FLN	70	22985	16	WASHER FLAT #6 - M4
20	49939	1	RECTIFIER NSC 12A 600V #1N1206R	71	31879	4	WASHER FLAT #4 - M3
21	50123	1	KNOB PLASTIC .25 SHAFT	72	43182	6	WASHER LOCK M3
22	54450	1	CIRCT BRK 5.5 X 1ETA 46-500-P	73	51714	6	NUT HEX M3-0.5
23	55405	1	GAUGE OIL PRESSURE	74	75476	10	SCREW PPHM M4 X 16
24	55406	1	GAUGE COOLANT TEMPERATURE	75	51715	18	NUT HEX M4-0.7
25	55444	1	HEAT SINK 13.3L	76	22264	18	WASHER LOCK M4
26	55920	1	SWITCH 1PST SPADE PNL MNT	77	23897	15	WASHER FLAT M5 ZINC
27	57073	1	BLOCK JUNCTION 3/8-16	78	51717	4	SCREW HHC M3-0.5 X 10
28**	57335	1	BLOCK CINCH 141 20 X 6 X 1100V	79	49815	4	SCREW HHC M5-0.8 X 16
29	57907	1	RESISTOR WW AX 10R 10% 25W	80	49226	26	WASHER LOCK M5
30	58568	2	TRANSFORMER 50A-5A CRNT XFRM/FEET	81	51716	24	NUT HEX M5-0.8
31	67625	1	SWITCH 3P TRIP THR 15/10A TGGL	82	51787	4	SCREW HHC M4-0.7 X 16
32	55867	1	SWITCH SPDT 15A SPD TGGL MOM	83	77682	2	SCREW HHC M5-0.8 X 80
33	61945	1	SWITCH 6A AMP/V SELECTOR	84	52619	6	SCREW HHC M5-0.8 X 20
34**	C5139	1	CONN DEUTSCH RECPT GY/FLN	85	D1290	2	SCREW SHC M5-0.8 X 16
35	64009	1	LIGHT 12VDC .02 LED RED	86	90987	2	SCREW PPHM M3 X 12
36	67680	1	REGULATOR ASSY. VOLTAGE B&D	87	22097	4	WASHER LOCK M6
37	70042	1	METER FREQUENCY 55-65 HZ	88	52618	10	SCREW HHC M5-0.8 X 12
38	70043	1	METER VOLT AC 0-300	89	A1661	2	RIVET POP .156 X .160 - .164/#20
39	70054	1	AMMETER AC 0-50	90	36261	4	RIVET POP .125 X .129 - .133/#30
40	70081	1	METER HOURS	91	64526	8	SCREW TAP HWH #6-25 X 3/8 Z
41	70082	2	LIGHT BLOCKER	92	A1495	2	SCREW TAP M4 X 10 BP
42	70202	2	LIGHT PANEL #26306C	93	A4669	4	COVER TERMINAL BLOCK
43	71361	1	PONTENIO PNL 5K +/- 10% 2.25W	94	C2267	13	SCREW HHM SWAGE M5-0.8 X 12 Z/YC
44	71938A	1	REGULATOR DC NO CHROMATE	95	84932	2	SCREW HHC M4-0.7 X 30
45	76037	1	METER VOLT DC 8-18V	96	C3211H	2	SPRING RELAY RETAINING
46	A4680A	1	CIRCT BRK 35 X 2 240V	97	C6752	2	SCREW TAP M5 X 25 BP
47	77906A	1	CIRCT BRK 30 X 2 240V	98	23762	1	WASHER SHAKEPROOF EXT. #10 STEEL
48	83089	1	BOARD "C" CONTROL 12/24 V	99	22158	1	HEX NUT #10-32 STEEL
49	C5143	2	CONN DEUTSCH SEALING PIN BLKHD	100	C8988	1	CONN DEUTSCH HDC16-6 DUST CAP
50	94373	1	RECEPT DUPLEX 15A GFCI				
51	32300	1	FUSE HOLDER				

* NOT SHOWN - SEE WIRING DIAGRAM #C9257
 ** ITEMS INCLUDED IN WIRE HARNES #C9420



Section 8 — Exploded Views and Parts Lists

Generac GR-8 Standby Generator
Generator — Drawing No. C9413-B

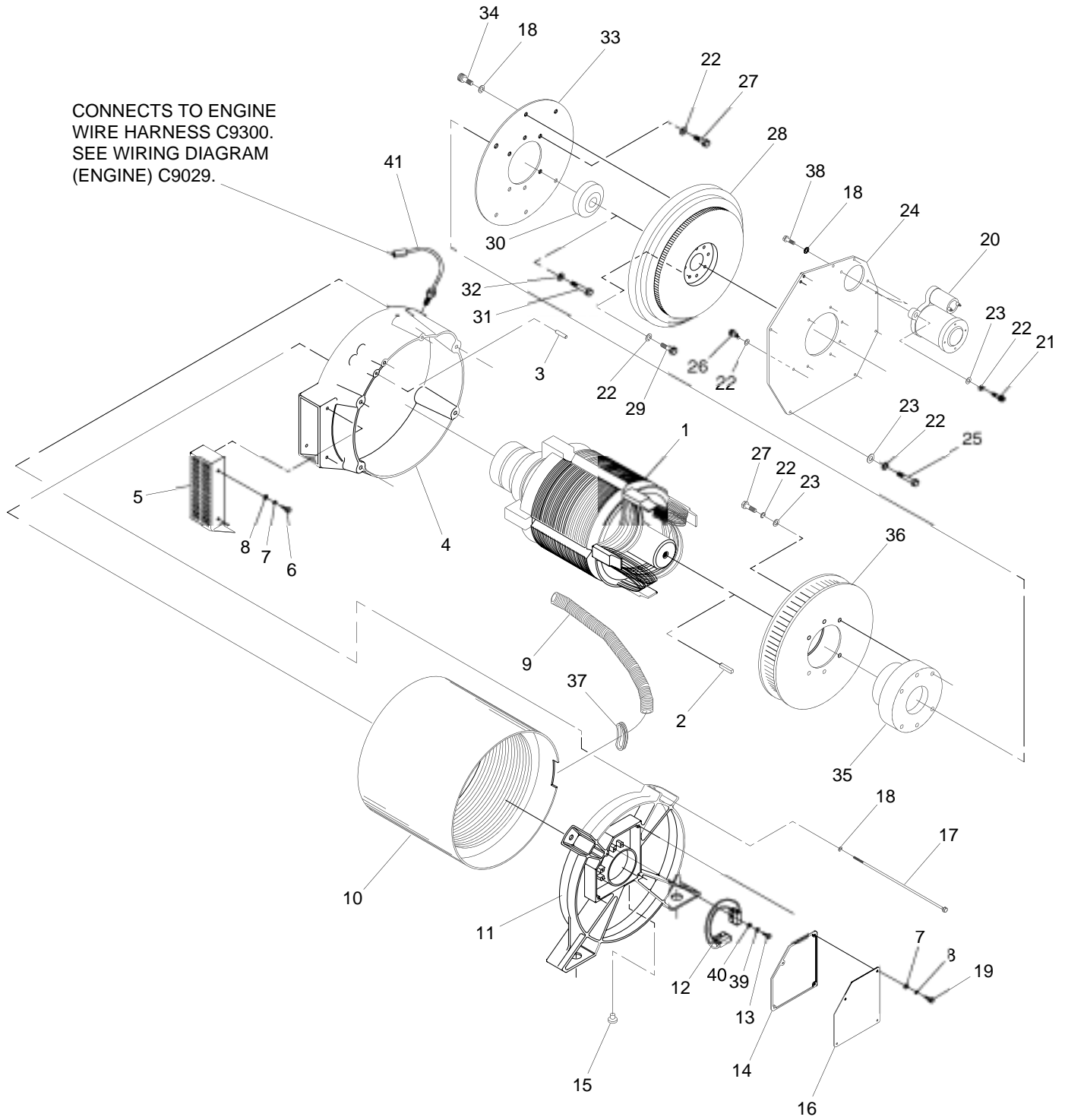

Section 8 — Exploded Views and Parts Lists

Generac GR-8 Standby Generator
Generator — Drawing No. C9413-B

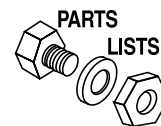

ITEM	PART NO.	QTY.	DESCRIPTION
1	77900	1	ROTOR ASSEMBLY 8KW
2	42558	1	KEY SQ 3/8 X 1 STEEL
3	48189	2	PIN DOWEL M3 X 24
4	87714A	1	HOUSING BLOWER
5	74243	1	SCREEN AIR OUTLET
6	72512	4	SCREW HHC M6-1.00 X 8
7	22097	8	WASHER LOCK M6-1/4
8	22473	8	WASHER FLAT M6-1/4 ZINC
9	77043C	1	GUARD FLEX 3/4 X 10
10	76019B	1	STATOR ASSEMBLY 8KW
11	69804A	1	CARRIER REAR BEARING
12	75591A	1	HOLDER BRUSH - ASSEMBLY
13	20745	4	SCREW PPHM M4-0.7 X 12
14	69892	1	GASKET REAR BEARING
15	70992	1	ARRESTER FLAME
16	98323	1	PLATE COVER
17	75554	4	BOLT STATOR
18	22129	12	WASHER LOCK M8-5/16
19	47411	4	SCREW HHC M6-1.0 X 16 G8.8
20	134-70939	1	MOTOR STARTER
21	20747	2	SCREW SH M10-1.5 X 35
22	46526	31	WASHER LOCK M10
23	22131	11	WASHER FLAT M10-3/8 ZINC
24	73450B	1	PLATE ENGINE
25	49814	3	SCREW HHC M10-1.5 X 25 G8.8
26**	51756	8	SCREW HHC M10-1.5 X 20 G8.8
27*	23152	12	SCREW HHC 3/8-16 X 3/4 G5
28	73451	1	FLYWHEEL ASSEMBLY W/RING GEAR
29**	62963	6	SCREW HHC M10-1.25 X 30 G8.8
30***	72578	1	SPACER FOR ROTOR SHAFT
31	53557	1	SCREW HHC M12-1.75 X 40 G8.8
32	51769	1	WASHER LOCK M12
33	73454A	1	PLATE COUPLING
34 *	75789	6	SCREW SHC 5/16-18 X 3/4
35	73452	1	HUB DRIVE
36	73455	1	FAN GENERATOR
37	63212	1	GROMMET 1.75 X .12 X 1.50
38	39253	2	SCREW HHC M8-1.25 X 20 G8.8
39	71952	4	WASHER LOCK #10
40	23365	4	WASHER SHAKEPROOF INT #8
41	D2244M	1	ASSEMBLY MAGPICKUP (3/8-24 MALE)

TORQUE-FT. LBS

* 12

** 25

*** 42

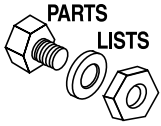

Section 8 – Exploded Views and Parts Lists

Generac GR-8 Standby Generator

Engine – Drawing No. C9363-B

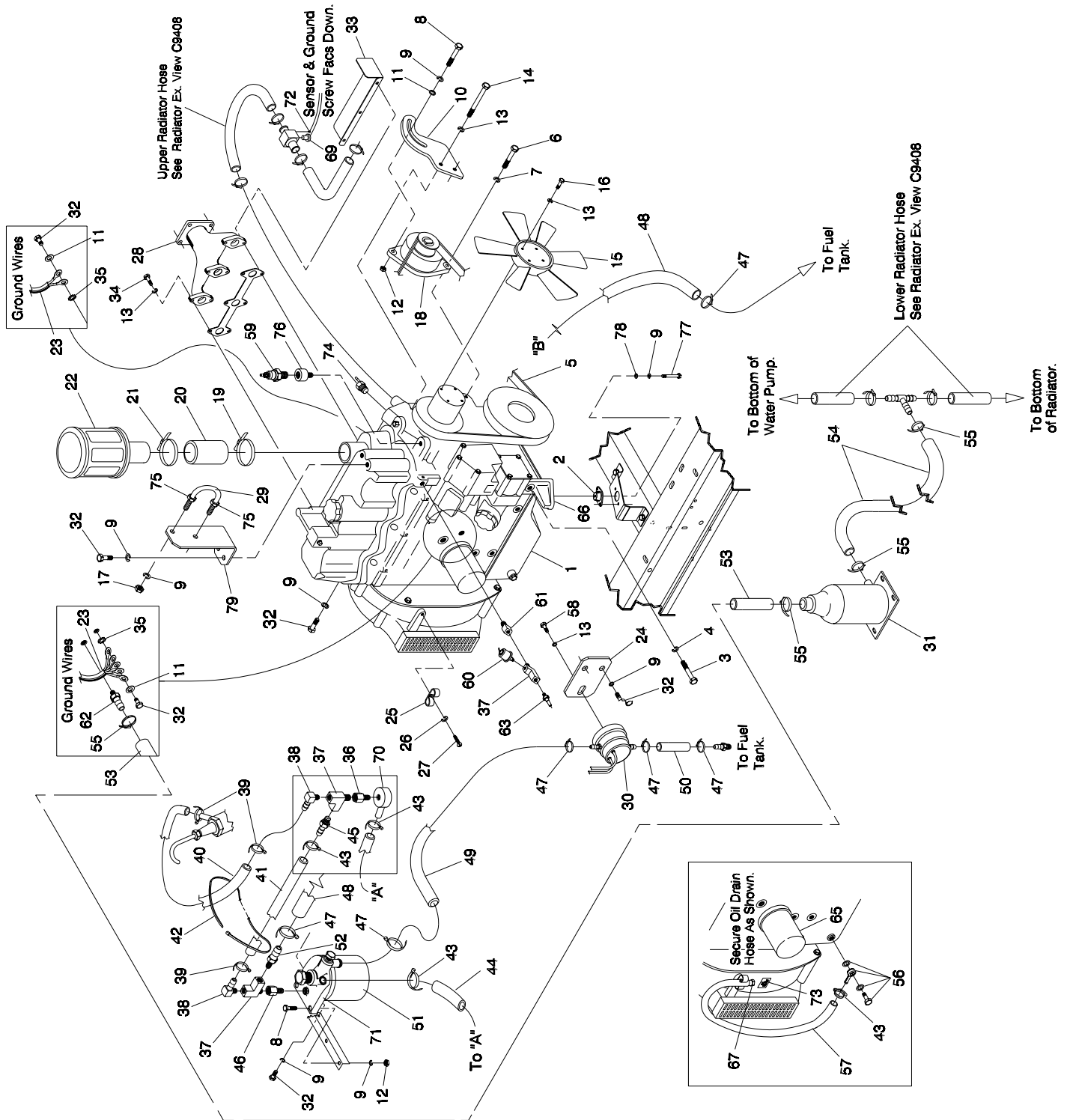

Section 8 — Exploded Views and Parts Lists

Generac GR-8 Standby Generator
Engine — Drawing No. C9363-B

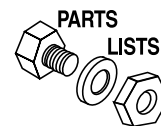

ITEM	PART NO.	QTY.	DESCRIPTION	ITEM	PART NO.	QTY.	DESCRIPTION
1	70939	1	ENGINE ISM 1L DIESEL	42	28739A	1	TIE WRAP 4" BLACK
2	70936	2	DAMPENER VIBRATION	43	70928	3	CLAMP HOSE - OIL DRAIN
3	75672	4	SCREW HHC M12-1.25 X 40 G8.8	44	52221	1	HOSE RES 5/16 TYP1 SNGL
4	51769	4	WASHER LOCK M12	45	30096	1	BARB STREET 3/16 X 1/8 X 1.19
5	46233	1	V-BELT 3/8 X 30-1/8	46	74819	1	FITTING - FUEL BLEED 3/4 HEX
6	57642	1	SCREW HHC M10-1.5 X 40	47	40173	6	CLAMP HOSE #5.5 .62 - .62
7	46526	1	WASHER LOCK M10	48	52221	1	HOSE RES 5/16 TYP1 SNGL-570MM
8	42909	3	SCREW HHC M8-1.25 X 30	49	52221	1	HOSE RES 5/16 TYP1 SNGL-205MM
9	22129	20	WASHER LOCK 5/16-M8	50	52221	1	HOSE RES 5/16 TYP1 SNGL-120MM
10	77909	1	BRACKET ALTERNATOR	51	69858	1	FILTER FUEL
11	22145	3	WASHER FLAT 5/16-M8	52	52219	1	BARB STRAIGHT 5/16 X 1/8 X 1.47
12	45771	3	NUT HEX M8-1.25	53	50967	1	HOSE RES 5/8 RIA 250F-18"
13	22097	16	WASHER LOCK 1/4-M6	54	50967	1	HOSE RES 5/8 RIA 250F-14"
14	57058	2	SCREW HHC M6-1.0 X 55	55	57823	4	CLAMP HOSE #10 .56 - 1.06
15	77910	1	FAN ENGINE	56	72573	1	FITTING OIL - BANJO ASSEMBLY
16	47411	5	SCREW HHC M6-1.0 X 16	57	69860E	1	HOSE OIL DRAIN ASSEMBLY 28"
17	22259	2	NUT HEX 5/16-18 STEEL	58	22507	2	SCREW HHC 1/4-20 X 1/2 G5
18	C9850	1	ALTERNATOR DIRECT CURRENT	59	35606	1	SENSOR HI COOLANT SHUTDOWN
19	39294	2	CLAMP HOSE #44 2.31 - 3.25	60	53666	1	SENDER OIL PRESSURE
20	59399A	1	HOSE 1-3/4 X 2	61	42574	1	ADAPTOR 1/8 NPTF TO 1/8-28
21	35685	1	CLAMP HOSE #28 1.32 - 2.25	62	84033	1	BARB STRAIGHT 3/4 X 5/8
22	70941	1	FILTER AIR	63	A8584	1	SWITCH OIL PRESSURE
23*	C9300	1	ENGINE HARNESS	64*	68-44114	1	WIRE ASSEMBLY - GROUND STRAP
24	A3485	1	BRACKET FUEL PUMP	65	126-70939	1	FILTER OIL
25	65852	1	NUT SPRINGCLIP .37 - .62	66	72501	2	MOUNT ENGINE
26	71952	1	WASHER LOCK #10	67	69811	1	CAP HEX 1/4 NPT BRASS
27	71912	1	SCREW PPHM M5-0.8 X 8	69	57522	1	SENSOR COOLANT LEVEL
28	75673	1	MANIFOLD EXHAUST	70	379-70939	1	FITTING BANJO
29	28238	1	BOLT STIR 5/16-18 X 1.53	71	661-70939	1	FILTER FUEL ASSEMBLY ISM
30	C9819	1	PUMP ASSEMBLY - ELEC. FUEL	72	46852	1	SCREW TAPTITE #10-32 X 1/4 BP
31	C9432	1	HEATER BLOCK 500W	73	50227	1	DECAL OIL DRAIN
32	42907	11	SCREW HHC M8-1.25 X 16	74	167-70939	1	SWTICH THERMO
33	75692	1	SHIELD HEAT - EXH. MANIFOLD	75	25244	2	NUT HEX JAM 5/16-18 STEEL
34	45757	6	SCREW HHC M6-1.0 X 25	76	35468	1	BUSHING REDUCER 3/8 TO 1/4 BRASS
35	22261	2	WASHER SHAKEPROOF INT 3/8	77	51730	4	SCREW HHC M8-1.25 X 60
36	74808	1	FITTING - FUEL BLEED	78	71956	4	WASHER FLAT M8 VIRATION ISOLATOR
37	52233	3	PIPE TEE 1/8 NPT BRASS	79	C9390	1	BRACKET RADIATOR HOSE
38	39450	2	BARB ELBOW 3/16 X 1/8				
39	74823	4	CLAMP HOSE .38 ID				
40	68736	1	HOSE RES 3/16 FUEL SNGL X 13" LONG				
41	68736	1	HOSE RES 3/16 FUEL SNGL X 8" LONG				

* NOT SHOWN

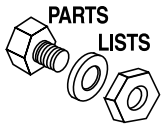

Section 8 — Exploded Views and Parts Lists

Generac GR-8 Standby Generator Radiator — Drawing No. C9408-A

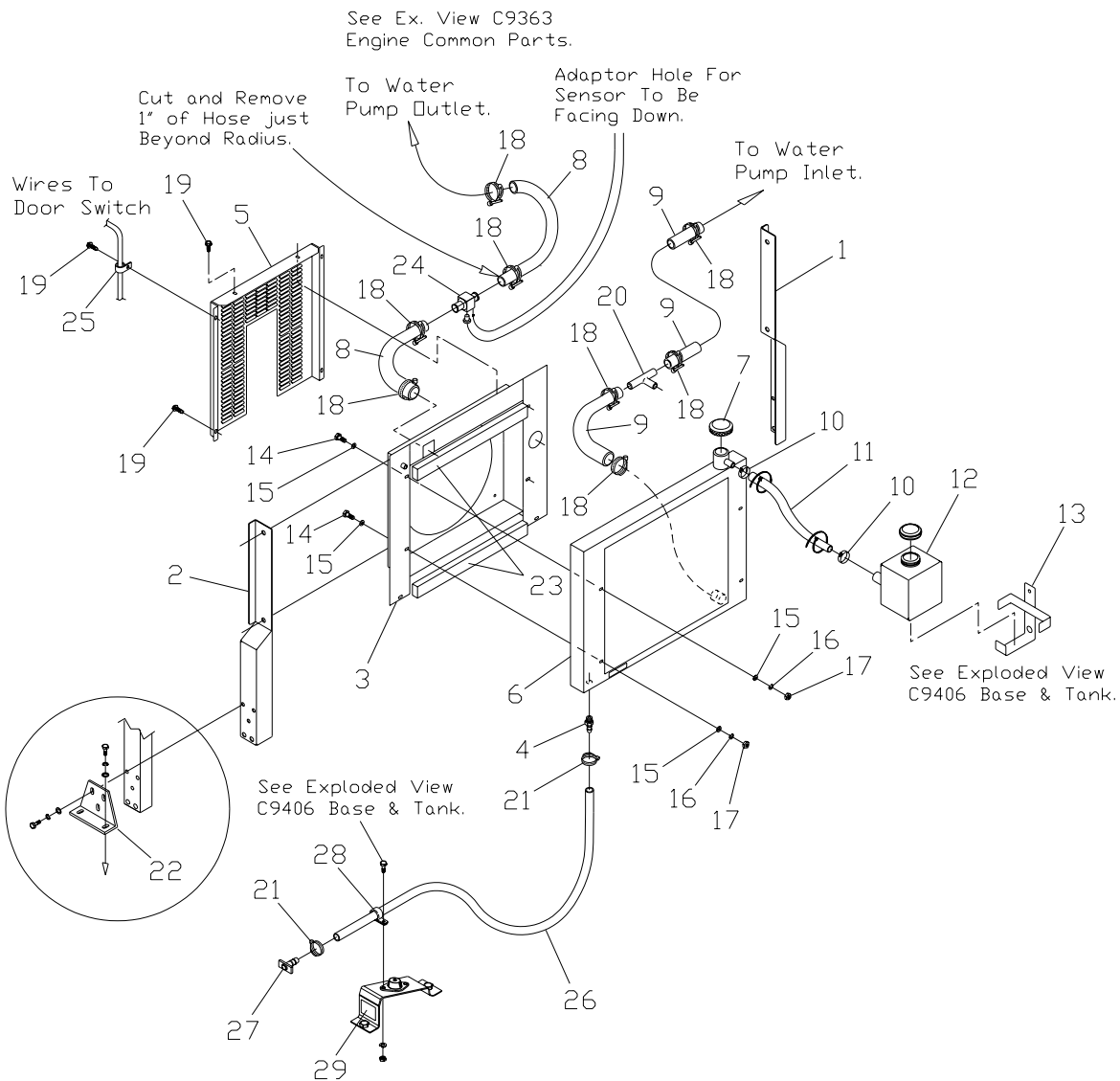

ITEM	PART NO.	QTY.	DESCRIPTION	ITEM	PART NO.	QTY.	DESCRIPTION
1	A3483	1	BRACKET RADIATOR RH	16	22129	4	WASHER LOCK M8
2	A3484	1	BRACKET RADIATOR LH	17	45771	4	NUT HEX M8-1.25
3	C7925	1	VENTURI	18	57824	8	CLAMP HOSE .87 - 1.50
4	35461	1	BARB STRAIGHT 3/8 X 1/4 X 1.72	19	75443	6	SCREW CRIMPTITE 1/4-20 X 5/8
5	A3826	1	GUARD FAN	20	79929	1	TEE 1 X 1 X 5/8
6	A4353	1	RADIATOR ASSEMBLY	21	40173	2	CLAMP HOSE #5.5 .62 - .62
7	46627	1	RADIATOR CAP	22	A5746	2	BRACKET RADIATOR SUPPORT
8	77444	1	UPPER RADIATOR HOSE	23	52250	2	FOAM STRIP 3/4 X 1 X 20
9	77913	1	LOWER RADIATOR HOSE	24	84432	1	ADAPTOR, SENSOR
10	83709	2	SPRING CLAMP #9	25	55934A	1	CLAMP VINYL .62 X .281 X .5 Z
11	29032	1	HOSE 5/16 ID. X 36	26	47290	3.33 FT	HOSE RES 3/8 SINGLE BRAID
12	76749	1	BOTTLE COOLANT RECOVERY	27	36865	1	DRAINCOCK
13	80712	1	BRACKET COOLANT RECOVERY	28	55934F	1	CLAMP VINYL .62 X .343 Z
14	42907	4	SCREW HHC M8-1.25 X 16	29	50276	1	DECAL RADIATOR DRAIN
15	22145	8	WASHER FLAT M8				

Section 8 — Exploded Views and Parts Lists

Generac GR-8 Standby Generator
Muffler — Drawing No. C9421-A

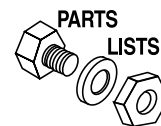

Install Exhaust Insulation Over
Flex Exhaust From A To B.
Secure With Clamp P/N 35685 At A
And P/N 24005 At B.

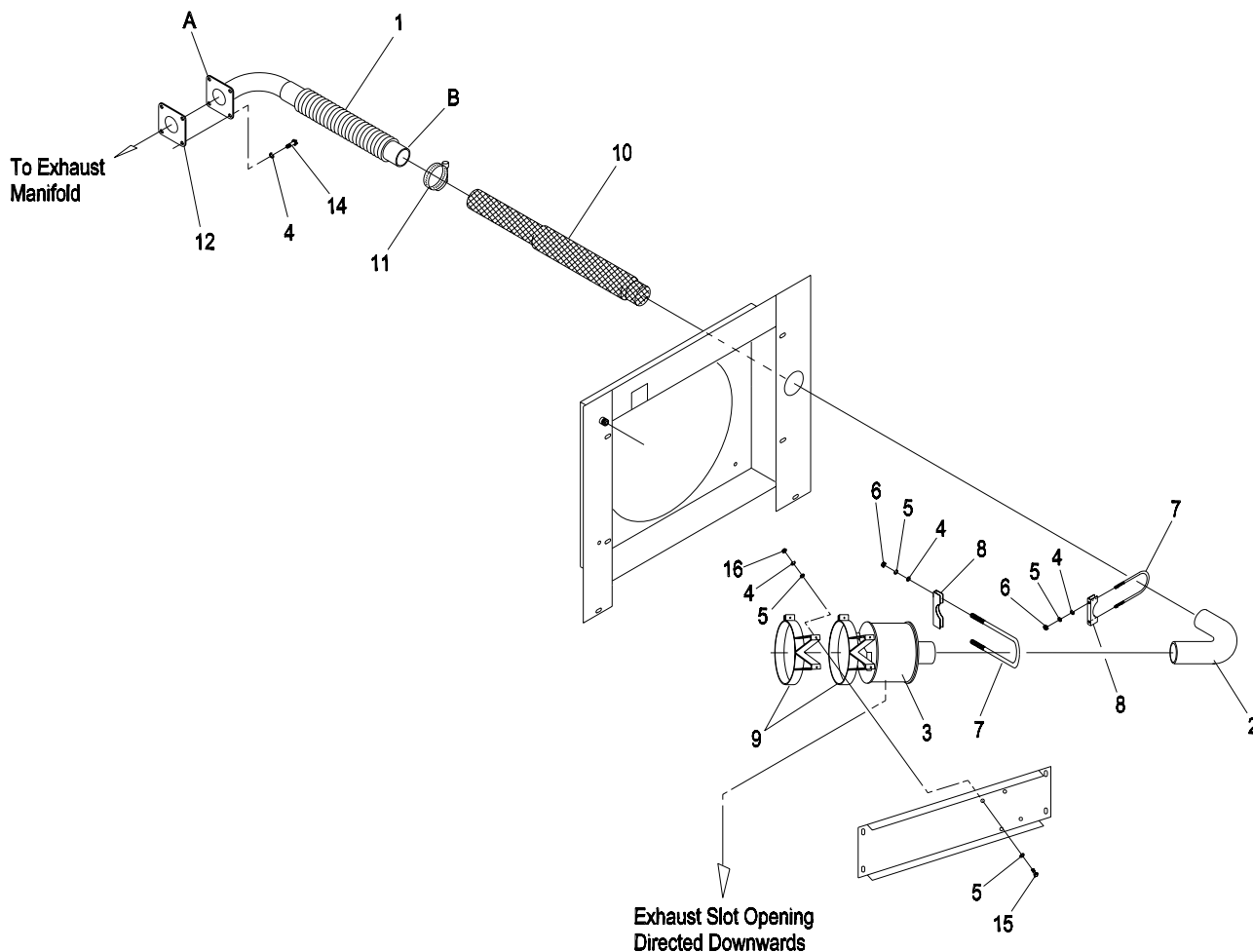

ITEM	PART NO.	QTY.	DESCRIPTION
1	A3591	1	EXHAUST FLEX 8KW TRAILER
2	A3904	1	EXHAUST ELBOW 1.5"
3	A3905	1	SILENCER 1.0L 8KW TRAILER
4	22129	12	WASHER LOCK 5/16-M8
5	22145	12	WASHER FLAT M8-5/16 ZINC
6	22259	4	NUT HEX 5/16-18 STEEL
7	24005	2	BOLT STIR 5/16-18 X 1.75
8	53413	2	SADDLE 1-5/8 X 1.80
9	77767A	2	CLAMP MUFFLER MOUNT 7.0 OD
10	C9422	1	INSULATION EXHAUST
11	35685	2	CLAMP HOSE #28 1.32 - 2.25
12	75674	1	GASKET EXHAUST ADAPTOR
14	43107	4	SCREW HHC M8-1.25 X 25 G8.8
15	39253	4	SCREW HHC M8-1.25 X 20 G8.8
16	45771	4	NUT HEX M8-1.25



Section 8 – Exploded Views and Parts Lists

Generac GR-8 Standby Generator

Battery – Drawing No. C9410

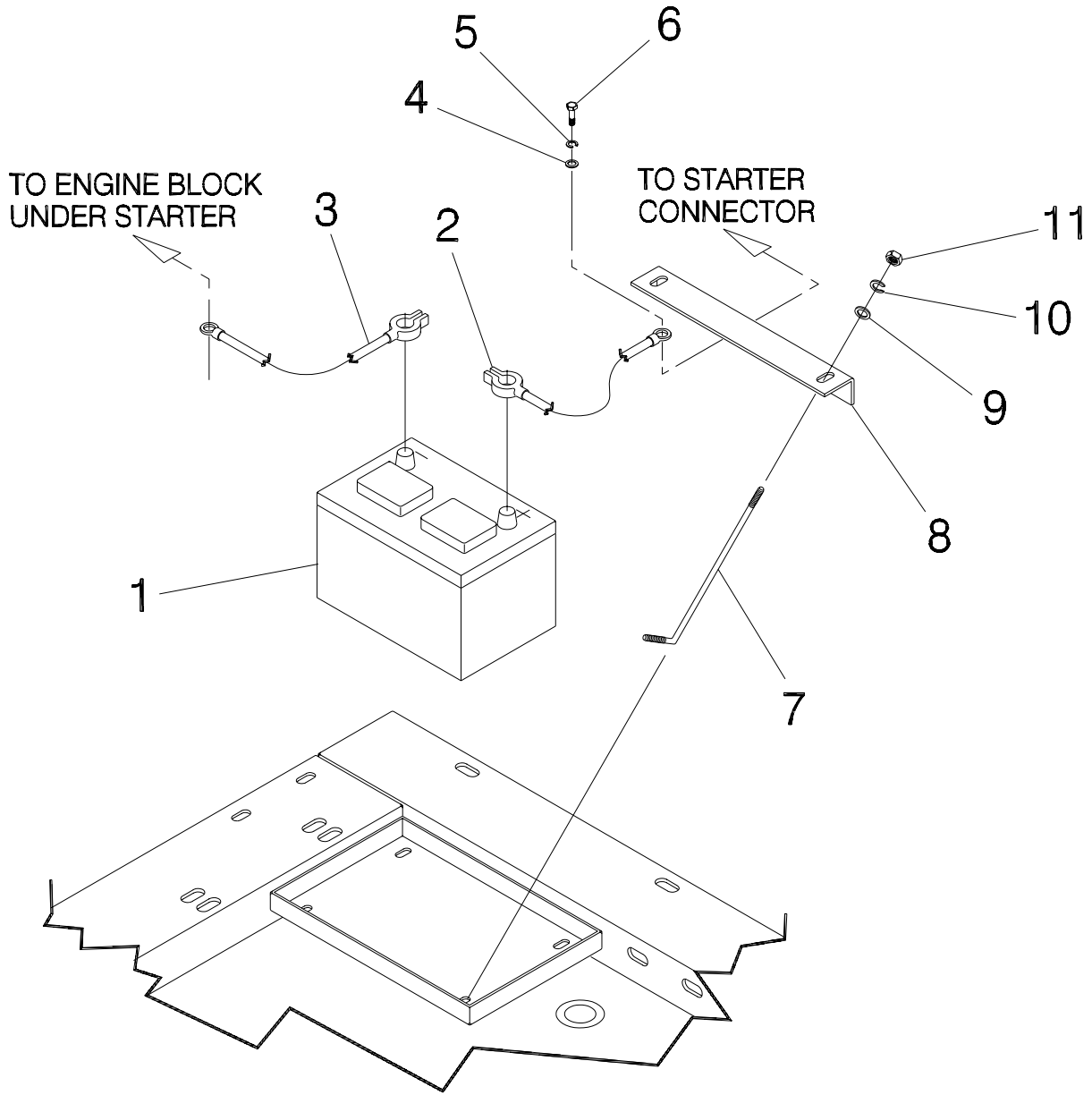

ITEM	PART NO.	QTY.	DESCRIPTION
1	77483	-	BATTERY, GROUP 26
2	AD38804	1	CABLE BATT RED #1X24.00X0.50
3	38805H	1	CABLE BATT BLK #1X23.00X0.50
4	49808	1	WASH FLAT M12X13.0X24.0
5	51769	1	WASH LOCK M12 X 12.2
6	68485	1	SCREW HHC M12-1.25 X 20
7	59567	2	J-BOLTS, BATTERY HOLD-DOWN
8	78121	1	BAR, HOLD-DOWN
9	22145	2	WASHER FLAT 5/16-M8
10	22129	2	WASHER LOCK 5/16-M8
11	22259	2	NUT HEX 5/16-18 STEEL

Section 8 — Exploded Views and Parts Lists

Generac GR-8 Standby Generator Battery Charger — Drawing No. C9459-B

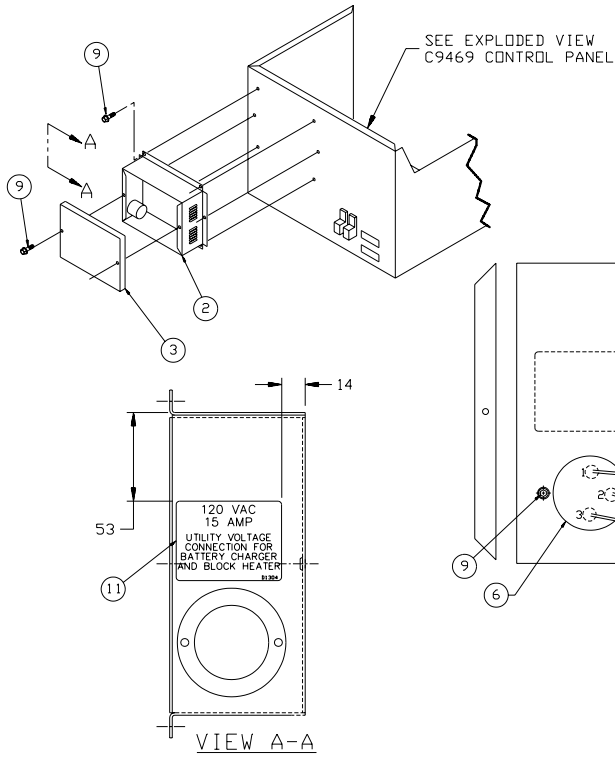
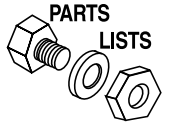

WIRE #	LENGTH	WIRE P/N	LUG #1	LUG #2	FROM	TO
0	215	93914B	61531	71270	2T	J1A
00	250	93914B	61531	STRIP/TIN	6B	RECP. #3
13	215	93914A	61531	71270	1T	J1B
L1	250	93914I	61531	STRIP/TIN	4B	RECP. #1
GND	250	55199I	61531	STRIP/TIN	3T	RECP. #2

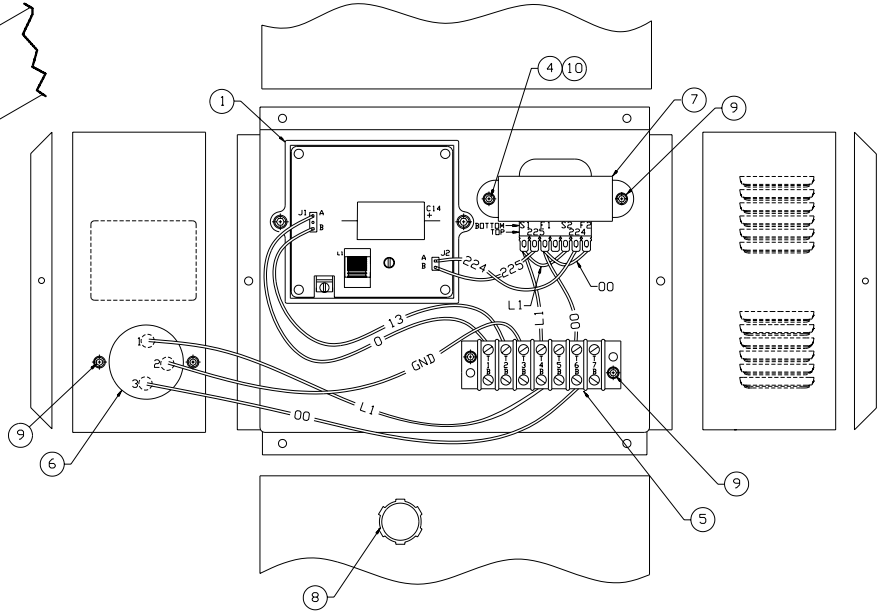

ITEM	PART NO.	QTY.	DESCRIPTION
1	A1801	1	ASSEMBLY ENGINE BATTERY CHARGER
2	C8569	1	BATTERY CHARGER ENCLOSURE
3	C8570	1	BATTERY CHARGER COVER
4	29187	2	SPACER .19 X .31 X .50 ST/ZINC
5	47822	1	BLOCK CINCH 141 7 X 6 X 1100V
6	69174	1	DEUTSCH RECEPTAL MALE
7	D1254	1	ASSEMBLY TRANSFORMER
8	22206	1	FITTING STRAIGHT 3/8"
9	A1495	14	SCREW TAP M4 X 8 BP
10	D1907	2	SCREW TAP M5 X 50 BP
11	D1304	1	DECAL UTILITY CONNECTION



Section 9 – Warranty

Generac GR-8 Standby Generator

NOTE: This Emission Control Warranty Statement applies only to mobile (trailerized) non-road diesel engine powered generators (model year 2000) as follows: The EPA portion of this statement pertains to this product; The CARB portion of this statement pertains to this product only IF the generator size is (1) 15 kW or below OR (2) 130 kW or greater.

CALIFORNIA AND FEDERAL EMISSION CONTROL WARRANTY STATEMENT

YOUR WARRANTY RIGHTS AND OBLIGATIONS

The California Air Resources Board (CARB) and the United States Environmental Protection Agency (EPA), together with Generac Power Systems, Inc. (Generac), are pleased to explain the Emission Control System Warranty on your new non-road diesel engine.* New non-road diesel engines must be designed, built and equipped to meet stringent anti-smog standards for the state of California and the federal government. Generac will warrant the emission control system on your non-road diesel engine for the periods of time listed below provided there has been no abuse, neglect, unapproved modification or improper maintenance of your non-road diesel engine.

Your emission control system may include such parts as the fuel injection system and the air induction system. Also included may be hoses, belts, connectors and other emission-related assemblies. Generac will repair your non-road diesel engine at no cost to you for diagnosis, replacement parts and labor, should a warrantable condition occur.

MANUFACTURER'S EMISSION CONTROL SYSTEM WARRANTY COVERAGE:

Emission control systems on 1996 and later model year non-road diesel engines are warranted for five years, or 3,000 hours of use, whichever occurs first. In the absence of an hourmeter, the said coverage is five years. If, during said warranty period, any emission-related component or system on your engine is found to be defective in materials or workmanship, repairs or replacement will be performed by a Generac Authorized Warranty Service Facility.

PURCHASER'S/OWNER'S WARRANTY RESPONSIBILITIES:

As the non-road diesel engine purchaser/owner, you are responsible for the completion of all required maintenance as listed in your factory supplied Owner's Manual. For warranty purposes, Generac recommends that you retain all receipts covering maintenance of your non-road diesel engine. However, Generac cannot deny warranty solely due to lack of receipts or for your failure to ensure the completion of all scheduled maintenance.

As the non-road diesel engine purchaser/owner, you should, however, be aware that Generac may deny any and/or all warranty coverage or responsibility if your non-road diesel engine, or a part/component thereof, has failed due to abuse, neglect, improper maintenance or unapproved modifications., or the use of counterfeit and/or "grey market" parts not made, supplied or approved by Generac.

Your engine is designed to operate on diesel fuel only. Use of any other fuel may result in your engine no longer operating in compliance with federal or California emission requirements.

You are responsible for contacting a Generac Authorized Warranty Service Facility as soon as a problem occurs. The warranty repairs should be completed in a reasonable amount of time, not to exceed 30 days.

Warranty service can be arranged by contacting either your selling dealer or a Generac Authorized Warranty Service Facility. To locate the Generac Authorized Warranty Service Facility nearest you, call our toll-free number:

1-800-333-1322

IMPORTANT NOTE: This Warranty statement explains your rights and obligations under the Emission Control System Warranty (ECS Warranty), which is provided to you by Generac pursuant to federal and California law. See also the "Generac Limited Warranties for Generac Power Systems, Inc.," which is enclosed herewith on a separate sheet, also provided to you by Generac. The ECS Warranty applies **only** to the emission control system of your new non-road diesel engine. If there is any conflict in terms between the ECS Warranty and the Generac Warranty, the ECS Warranty shall apply except in circumstances where the Generac Warranty may provide a longer warranty period. Both the ECS Warranty and the Generac describe important rights and obligations with respect to your new non-road diesel engine.

Warranty service can be performed only by a Generac Authorized Warranty Service Facility. When requesting warranty service, evidence must be presented showing the date of sale to the original purchaser/owner.

If you have any questions regarding your warranty rights and responsibilities, you should contact Generac at the following address:

ATTENTION WARRANTY DEPARTMENT
GENERAC POWER SYSTEMS, INC.
211 MURPHY DRIVE
EAGLE, WI 53119



EMISSION CONTROL SYSTEM WARRANTY

Emission Control System Warranty (ECS Warranty) for 1996 and later model year non-road diesel engines:

- (a) **Applicability:** This warranty shall apply to 1996 and later model year non-road diesel engines. The ECS Warranty shall begin on the date the new engine or equipment is purchased by/delivered to its original, end-use purchaser/owner and shall continue for 60 months, or 3,000 hours of use, thereafter, whichever occurs first.
- (b) **General Emissions Warranty Coverage:** Generac warrants to the original, end-use purchaser/owner of the new non-road diesel engine or equipment, and to each subsequent purchaser/owner, that each non-road diesel engine is ...
- (1) Designed, built and equipped so as to conform with all applicable regulations adopted by the EPA and CARB pursuant to their respective authority, and
 - (2) Free from defects in materials and workmanship, which, at any time during the ECS Warranty Period, may cause a warranted emission-related part to fail to be identical in all material respects to the part as described in the engine manufacturer's application for certification.
- (c) The ECS Warranty pertains only to emissions-related parts on your non-road diesel engine, as follows:
- (1) Any warranted, emissions-related parts that are not scheduled for replacement as required maintenance in the Owner's Manual shall be warranted for the ECS Warranty Period. If any such part fails during the ECS Warranty Period, it shall be repaired or replaced by Generac according to Subsection (4) below. Any such part repaired or replaced under the ECS Warranty shall be warranted for the remainder of the ECS Warranty Period.
 - (2) Any warranted, emissions-related part that is scheduled only for regular inspection as specified in the Owner's Manual shall be warranted for the ECS Warranty Period. A statement in such written instructions to the effect of "repair or replace as necessary" shall not reduce the ECS Warranty Period. Any such part repaired or replaced under the ECS Warranty shall be warranted for the remainder of the ECS Warranty Period.
 - (3) Any warranted, emissions-related part that is scheduled for replacement as required maintenance in the Owner's Manual shall be warranted for the period of time prior to the first scheduled replacement point for that part. If the part fails prior to the first scheduled replacement, the part shall be repaired or replaced by Generac according to Subsection (4) below. Any such emissions-related part repaired or replaced under the ECS Warranty shall be warranted for the remainder of the ECS Warranty Period prior to the first scheduled replacement point for such emissions-related part.
 - (4) Repair and replacement of any warranted, emissions-related part under this ECS Warranty shall be performed at no charge to the owner by a Generac Authorized Warranty Service Facility.
 - (5) When the engine is inspected by a Generac Authorized Warranty Service Facility, the owner shall not be held responsible for diagnostic costs if the repair is deemed warrantable.
 - (6) Generac shall be liable for damages to other original engine components or approved modifications proximately caused by a failure under warranty of any emissions-related part covered by the ECS Warranty.
 - (7) Throughout the ECS Warranty Period, Generac shall maintain a supply of warranted emissions-related parts sufficient to meet the expected demand for such emission-related parts.
 - (8) Any Generac authorized and approved emission-related replacement part may be used in the performance of any ECS warranty maintenance or repairs and will be provided without charge to the owner. Such use will not reduce Generac's ECS Warranty obligations.
 - (9) Unapproved, add-on, modified, counterfeit and/or "grey market" parts may not be used to modify or repair a Generac non-road diesel engine. Such use voids this ECS warranty and shall be sufficient grounds for disallowing an ECS Warranty claim. Generac shall not be held liable hereunder for failures of any warranted parts of a Generac non-road diesel engine caused by the use of such an unapproved, add-on, modified, counterfeit and/or "grey market" part.

EMISSION RELATED PARTS INCLUDE THE FOLLOWING:

- | | |
|--|---|
| <ol style="list-style-type: none">1) Fuel Metering System:<ol style="list-style-type: none">a) Fuel injection system2) Air Induction System:<ol style="list-style-type: none">a) Intake manifold and gasketb) Turbocharger systems (if so equipped)c) Charge air cooling systems (if so equipped) | <ol style="list-style-type: none">3) Exhaust System:<ol style="list-style-type: none">a) Exhaust manifold and gasket (turbocharged engines only)b) Catalytic converter (if so equipped)4) Miscellaneous Items used in above systems:<ol style="list-style-type: none">a) Hoses, connectors, assemblies, clamps, fittings, tubing, sealing gaskets or devices, and mounting hardware |
|--|---|

*Generac non-road diesel engine types covered by this warranty statement include the following:

- 1) Standby Generator

Part 2



Section 9 – Warranty

Generac GR-8 Standby Generator

GENERAC POWER SYSTEMS STANDARD 2-YEAR LIMITED WARRANTY FOR GR SERIES/PRIME POWER UNITS

NOTE: ALL UNITS MUST HAVE A STARTUP INSPECTION PERFORMED BY AN AUTHORIZED GENERAC DEALER

For a period of 2 (two) years or 3,000 (three thousand) hours of operation from the date of sale, which ever occurs first. Generac Power Systems, Inc. will, at its option, repair or replace any part(s) which, upon examination, inspection, and testing by Generac Power Systems or a Generac Power Systems Authorized Warranty Service Facility. Found to be defective under normal use and service, in accordance with the warranty schedule set forth below. Any equipment that the purchaser/owner claims to be defective must be returned to and examined by the nearest Generac Power Systems Authorized Warranty Service Facility. All transportation costs under the warranty, including return to the factory, are to be borne and prepaid by the purchaser/owner. This warranty applies only to Generac Power Systems Generators used in "Standby" applications, as Generac Power Systems, Inc. have defined Standby, provided said generator has been initially installed and inspected on-site by a Generac Power Systems Authorized Service Dealer or branch thereof. A scheduled maintenance agreement with a local Authorized Generac Power Systems Dealer is highly recommended to verify adequate service has been performed on the unit throughout the warranty period. Limited to, and available only on Liquid Cooled units.

WARRANTY SCHEDULE

YEAR ONE — 100% (one hundred percent) coverage on mileage*, labor, and parts listed.

• **ALL COMPONENTS**

YEAR TWO — 100% (one hundred percent) coverage on parts listed.

• **ALL COMPONENTS — *PARTS ONLY**

- *Travel allowance is limited to 300 miles maximum, or 7.5 hours maximum (per occurrence), **round trip**, and only applies to permanently wired and mounted units.
- A Generac Power Systems, Inc. Transfer Switch is highly recommended to be used in conjunction with the genset. If a Non - Generac Power Systems, Inc. Transfer Switch is substituted for use and directly causes damage to the genset. No warranty coverage shall apply.
- All warranty expense allowances **are** subject to the conditions defined in Generac Power Systems Warranty, Policies, and Procedures Flat Rate Manual.
- Units that have been resold **are not** covered under the Generac Power Systems Warranty, as this Warranty **is not** transferable.

THIS WARRANTY SHALL NOT APPLY TO THE FOLLOWING:

1. Any unit built prior to January 1, 2002.
2. Unit enclosure is only covered against rust or corrosion the first year of the warranty provision.
3. Costs of normal maintenance i.e. tune-ups, associated part(s), adjustments, loose/leaking clamps, installation and start-up.
4. Use of Non-Generac replacement part(s) will void the warranty in its entirety.
5. Any failure caused by contaminated fuels, oils, coolants/antifreeze or lack of proper fuels, oils or coolants/antifreeze.
6. Failures due, but not limited to, normal wear and tear, accident, misuse, abuse, negligence, or improper installation or sizing.
7. Caused by any external cause or act of God such as collision, fire, theft, freezing, vandalism, riot or wars, lightning, earthquake, windstorm, hail, volcanic eruption, water or flood, tornado, hurricane, terrorist acts or nuclear holocaust.
8. Products that are modified or altered in a manner not authorized by Generac Power Systems in writing.
9. Any incidental, consequential or indirect damages caused by defects in materials or workmanship, or any delay in repair or replacement of the defective part(s).
10. Failure due to misapplication, misrepresentation, or bi-fuel conversion.
11. Telephone, telegraph, teletype or other communication expenses.
12. Living or travel expenses of person(s) performing service, except as specifically included within the terms of a specific unit warranty period.
13. Rental equipment used while warranty repairs are being performed i.e. rental generators, cranes, etc..
14. Overtime labor or more than one person performing repairs.
15. Any and all expenses incurred investigating performance complaints unless defective Generac materials and or workmanship were the direct cause of the problem.
16. *Engine coolant heaters (block-heaters), heater controls and circulating pumps after the first year.
17. *Starting batteries, fuses, light bulbs, and engine fluids, overnight freight cost for replacement part(s).

THIS WARRANTY IS IN PLACE OF ALL OTHER WARRANTIES, EXPRESSED OR IMPLIED, SPECIFICALLY, GENERAC POWER SYSTEMS MAKES NO OTHER WARRANTIES AS TO THE MERCHANTABILITY OR FITNESS FOR A PARTICULAR PURPOSE. Some states do not allow limitations on how long an implied warranty lasts, so the above limitation may not apply to you.

GENERAC POWER SYSTEMS ONLY LIABILITY SHALL BE THE REPAIR OR REPLACEMENT OF PART(S) AS STATED ABOVE. IN NO EVENT SHALL GENERAC POWER SYSTEMS BE LIABLE FOR ANY INCIDENTAL, OR CONSEQUENTIAL DAMAGES, EVEN IF SUCH DAMAGES ARE A DIRECT RESULT OF GENERAC POWER SYSTEMS, INC. NEGLIGENCE.

Some states do not allow the exclusion or limitation of incidental or consequential damages, so the above limitations may not apply to you. Purchaser/owner agrees to make no claims against Generac Power Systems, Inc. based on negligence.

This warranty gives you specific legal rights. You also may have other rights that vary from state to state.

GENERAC® POWER SYSTEMS, INC. • P.O. BOX 8 • WAUKESHA, WI 53187
PH: (262) 544-4811 • FAX: (262) 544-4851

Bulletin 0166300SBY / Printed in USA 2.02