

GENERAC[®]

POWER SYSTEMS, INC.

GR-25

Operation and Maintenance Manual

Standby Output 22 kW (27 kVA)
Prime Output 20 kW (25 kVA)

Liquid-cooled
Diesel Engine
Generator Set

Model No. 004058-1 (Trailerized)

*** This Manual Should Remain With The Unit ***

INTRODUCTION

This Owner's Manual was prepared especially for the purpose of familiarizing personnel with the operation and servicing of the applicable equipment.

Every effort was expended to make sure that the information and instructions in the Manual are accurate and current at the time the Manual was written. However, the manufacturer reserves the right to change, alter or otherwise improve product(s) at any time without prior notice.



CAUTION: Read all instructions and safety rules before attempting to operate or service this (and related) equipment. Protect yourself and others by strictly complying with these instructions and rules. Failure to comply with these safety rules may result in personal injury, death or damage to equipment and/or property. Retain these instructions for future reference.

■ READ THIS MANUAL THOROUGHLY

If you do not understand any portion of this manual, contact Generac or your nearest Generac Authorized Service Dealer for starting, operating and servicing procedures.

Throughout this publication, and on tags and decals affixed to the generator, DANGER, WARNING, CAUTION and NOTE blocks are used to alert you to special instructions about a particular operation that may be hazardous if performed incorrectly or carelessly. Observe them carefully.

These safety warnings cannot eliminate the hazards that they indicate. Common sense and strict compliance with the special instructions while performing the service are essential to preventing accidents.

The following definitions apply to DANGER, WARNING, CAUTION and NOTE blocks found throughout the manual.



DANGER: After this heading, read handling, installing, operating or servicing instructions that, if not strictly complied with, will result in personal injury.



WARNING: After this heading, read handling, installing, operating or servicing instructions that, if not strictly complied with, may result in personal injury.



CAUTION: After this heading, read instructions for handling, installing, operating or servicing the generator that, if not strictly complied with, could result in damage to equipment and/or property.

NOTE: After this heading, read explanatory statements that require special emphasis.

These symbols indicate the following:



Points out important safety information that, if not followed, could endanger personal safety and/or property.



Points out potential explosion hazard.



Points out potential fire hazard.



Points out potential electrical shock hazard.

The operator is responsible for proper and safe use of the equipment. Generac strongly recommend that the operator read this *Owner's Manual* and thoroughly understand all instructions before using this equipment. Generac also strongly recommend instructing other users to properly start and operate the unit. This prepares them if they need to operate the equipment in an emergency.

■ OPERATION AND MAINTENANCE

It is the operator's responsibility to perform all safety checks, to make sure that all maintenance for safe operation is performed promptly, and to have the equipment checked by an authorized dealer periodically. Normal maintenance service and replacement of parts are the responsibility of the owner/operator and, as such, are not considered defects in materials or workmanship within the terms of the warranty. Individual operating habits and usage contribute to the need for maintenance service.

Proper maintenance and care of your generator ensures a minimum number of problems and keeps operating expenses at a minimum. See a Generac authorized dealer/distributor for service aids and accessories.

■ HOW TO OBTAIN SERVICE

When the generator set requires servicing or repairs, simply contact an authorized service facility for assistance. Service technicians are factory-trained and are capable of handling all service needs.

When contacting an authorized service facility or the factory about parts and service, always supply the complete model number, serial number, and vin number of the unit as given on its data decal.

The warranty on the generator is included in this *Owner's Manual*, as well as listings for repair parts.

INTRODUCTION	Inside Front Cover	ENGINE PROTECTIVE DEVICES	12
Read This Manual Thoroughly	Inside Front Cover	Low Oil Pressure Switch	12
Operation and Maintenance	Inside Front Cover	High Coolant Temperature Switch	12
How to Obtain Service	Inside Front Cover	Low Coolant Level Sensor	12
SERVICE DEALER LOCATION	1	DC Control/Latch-Crank Circuit Board	12
SAFETY RULES	2	Engine Startup	12
IDENTIFICATION RECORD	4	After Fault Shutdown	12
Data Plate	4	Overspeed.....	12
EQUIPMENT DESCRIPTION	4	Overcrank Shutdown.....	13
Standard Generator Features	4	OPERATING INSTRUCTIONS	13
Generator Specifications.....	4	Before Starting	13
Engine Specifications	4	Starting the Engine	13
INSTALLATION	5	Shut Down	13
Standby Electric System	5	Operation In Ice Or Snow	13
EMERGENCY CIRCUIT ISOLATION	6	Grounding the Generator	13
TOTAL CIRCUIT ISOLATION	6	Ground Fault Protection	13
PREPARATION BEFORE USE	7	MAINTENANCE	14
Engine Lubrication	7	100-Hour Break In Period	14
Engine Coolant	7	100-Hour Break In	14
Fuel	7	RECOMMENDED ENGINE FLUIDS	14
Cord Sets - 120 Volts GFCI Duplex Receptacle	7	Engine Oil & Oil Level.....	14
120 Volt Locking Type Receptacle	8	Engine Coolant	15
Full Capacity Terminal Compression Lugs	8	Fuel.....	16
Transfer Switch Terminal.....	9	OWNER/OPERATOR PERIODIC MAINTENANCE.....	16
Starting Battery.....	9	BLEEDING THE FUEL SYSTEM.....	17
SWITCHES, METERS AND LIGHTS	10	PERIODIC MAINTENANCE LIST	17
AC Voltmeter	10	Daily	17
AC Ammeter	10	Every 50 Hours or 2 Weeks	17
Frequency Meter.....	10	Every 250 Hours	17
Oil Pressure Gauge	10	Every 600 Hours or 12 Months.....	17
Coolant Temperature Gauge.....	10	Every 1200 Hours or 24 Months.....	17
DC Ammeter	11	Every 2000 Hours	17
Hourmeter	11	ADJUSTMENT OF FUEL INJECTION TIMING.....	17
System Ready Lamp	11	ENGINE SPEED ADJUSTMENT.....	17
Pre-Heat Switch	11	VOLTAGE REGULATOR ADJUSTMENT	18
Fault Indicator Lamp	11	GENERATOR ROTOR BEARING	18
Start/Run/Off Switch	11	MAJOR REPAIRS	18
Auto/Off/Manual Switch	11	How to Order Parts	18
Panel Light	11	WIRING DIAGRAMS/SCHEMATICS	19
Voltage Adjust Dial	11	EXPLODED VIEWS	27
Phase Selection Switch	12	SCHEDULED MAINTENANCE & SERVICE	46
		WARRANTY	Back Cover

SERVICE DEALER LOCATION

TO LOCATE THE NEAREST GENERAC SERVICING DEALER, PLEASE CALL OUR 800 NUMBER.
ONLY DEALER LOCATION INFORMATION CAN BE OBTAINED AT THIS NUMBER.

1-800-333-1322



Important Safety Instructions

GR-25 Generator Set



THE MANUFACTURER SUGGESTS THAT THESE “RULES” FOR SAFE OPERATION BE COPIED AND POSTED IN POTENTIAL HAZARD AREAS. SAFETY SHOULD BE STRESSED TO ALL OPERATORS AND POTENTIAL OPERATORS OF THIS EQUIPMENT.



WARNING:



The engine exhaust from this product contains chemicals known to the state of California to cause cancer, birth defects or other reproductive harm.



WARNING:



This product contains or emits chemicals known to the state of California to cause cancer, birth defects or other reproductive harm.

Study these “SAFETY RULES” carefully before installing, operating or servicing this equipment. Become familiar with the Owner’s Manual and with the unit. The generator can operate safely, efficiently and reliably only if it is properly set up, operated and maintained. Many accidents are caused by failing to follow simple and fundamental rules or precautions.

Generac cannot possibly anticipate every possible circumstance that might involve a hazard. The warnings in this manual, and on tags and decals affixed to the unit, are, therefore, not all-inclusive. Make sure the procedure, work method or operating technique that is chosen does not render the generator unsafe.



DANGER: Despite the safe design of this generator set, operating this equipment imprudently, neglecting its maintenance or being careless can cause possible injury or death. Permit only responsible and capable persons to operate or maintain this equipment.



DANGER: Generator sets can be dangerous. Only suitably qualified personnel should attempt to install or work on this type of equipment.



DANGER: Potentially lethal voltages are generated by these machines. Ensure all steps are taken to render the machine safe before attempting to work on the generator set.



DANGER: Parts of the generator set are rotating and/or hot during operation. Exercise care near running generator sets.





For safety reasons, Generac recommends that the initial start-up of this equipment is carried out by a Generac Authorized Dealer.



- Adequate, unobstructed flow of cooling and ventilating air is critical to correct generator set operation. Do not alter the installation or permit even partial blockage of ventilation provisions, as this can seriously affect safe operation of the generator set.

- Diesel engine exhaust fumes contain carbon monoxide, which can be DEADLY. This dangerous gas, if breathed in sufficient concentrations, can cause unconsciousness or even death. This exhaust system must be properly installed, in strict compliance with applicable codes and standards. Following installation, do nothing that might render the system unsafe or make it non-compliant with such codes and standards. Inspect the exhaust system regularly to ensure that it is free from leaks and damage, and that it is not possible for fumes to enter any area where people or animals are located. Never operate this equipment with a leaking or defective exhaust system. Repair or replace any damaged or leaking component immediately.
- Keep hands, feet, clothing, etc., away from drive belts, fans, and other moving or hot parts. Never remove any drive belt or fan guard while the unit is operating.
- When working on this equipment, remain alert at all times. Never work on the equipment when you are physically or mentally fatigued.
- Before performing any maintenance on the generator set, disconnect its battery cables to prevent accidental start up. Disconnect the cable from the battery post indicated by a NEGATIVE, NEG or (–) first. Reconnect that cable last.
- This generator set may be capable of automatic, unattended operation, and may start and run at any time. To prevent possible injury under such conditions, NEVER work on a generator in automatic mode. Before commencing work, select the control system to “OFF,” disconnect the generator starting battery and isolate any other sources of electrical power to the machine (such as battery charger or engine heater supplies).
- Never use the generator or any of its parts as a step. Stepping on the unit can stress and break parts, and may result in dangerous operating conditions from leaking exhaust gases, fuel leakage, oil leakage, etc.
- Inspect the generator set regularly, and repair or replace all damaged or defective parts immediately.
- Remove the fuse from the battery charger before disconnecting the battery to minimize the chance of equipment damage.



-  **For fire safety, the generator must be installed and maintained properly. Installation always must comply with applicable codes, standards, laws and regulations. Adhere strictly to local, state and national electrical and building codes. Comply with regulations the Occupational Safety and Health Administration (OSHA) has established. Also, ensure that the generator is set up in accordance with the manufacturer's instructions and recommendations. Following proper set up, do nothing that might alter a safe installation and render the unit in noncompliance with the aforementioned codes, standards, laws and regulations.**

 - Keep a fire extinguisher near to the generator set at all times. Extinguishers rated "ABC" by the National Fire Protection Association are appropriate for use on generator sets and are useful for small fires. For more sophisticated fire protection systems, contact the local fire department for advice, or contact a specialist fire protection company.
-  **The generator set covered by this manual produces dangerous electrical voltages and can cause fatal electrical shock. Avoid contact with bare wires, terminals, connections, etc., while the unit is running. Ensure all appropriate covers, guards and barriers are in place before operating the generator set. If work must be done around an operating unit, stand on an insulated, dry surface to reduce shock hazard.**

 - The National Electric Code (NEC) requires the frame and external electrically conductive parts of the generator set to be connected to an approved earth ground. Local electrical codes also may require proper grounding of the generator electrical system.
- Operation of the generator set in damp or wet locations can be extremely hazardous. Electrical resistance to current is reduced whenever items become wet.
 - Never wear jewelry or watches when working on this equipment. Jewelry or watches can conduct electricity resulting in electric shock, or may get caught in moving components causing injury.
-  **In case of accident caused by electric shock, immediately shut down the source of electrical power. If this is not possible, attempt to free the victim from the live conductor. AVOID DIRECT CONTACT WITH THE VICTIM. Use a nonconducting implement, such as a board or a rope, to free the victim from the live conductor. If victim is unconscious, apply first aid and get immediate medical help.**
-  **Do not smoke around the generator set. Wipe up any fuel or oil spills immediately. Ensure that no combustible materials are left on or near the generator set, as FIRE or Explosion might result. Keep the area surrounding the generator set clean and free from debris.**

 - Diesel fuel can be hazardous. Regularly inspect the installation for leaks and rectify them immediately.

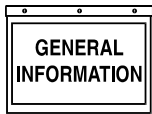

General Information

GR-25 Generator Set

IDENTIFICATION RECORD

DATA PLATE

Every generator has a DATA PLATE which contains important information pertinent to the generator. The data plate lists the unit's serial number, its rated voltage, amps, wattage capacity, phase, frequency, rpm, power factor, etc.

Generator Model Number: This number is the key to numerous engineering and manufacturing details pertaining to your unit. Always supply this number when requesting service, ordering parts, or seeking information.

Voltage Code X: The GR Series generators are capable of supplying a variety of single-phase and 3-phase voltages, in total referred to as an X voltage code. They include the following:

- 120/208 to 139/240 volts, single phase, 60 Hz.
- 120/208 to 139/240 volts, 3-phase, 60 Hz.
- 240/416 to 277/480 volts, 3-phase, 60 Hz.

Note:

The above voltage ratings are stated in the form, V_{ph}/V_L .

— V_{ph} is the phase voltage (i.e., voltage above neutral).

— V_L is the line-to-line voltage.

EQUIPMENT DESCRIPTION

This equipment is a revolving field, alternating current generator set. The generator is designed to supply electrical power for the operation of compatible, electrical loads when Utility Power is unavailable.

The generator's revolving field is directly connected to and driven by an engine by means of flexible discs and a coupling assembly. Units with 4-pole rotors are driven at speeds of 1800 rpm to supply a rated frequency of 60 Hz.

The units are mounted on highway transportable trailers equipped with breakaway safety chains and a jockey wheel. Weather-resistant, all-metal, sound-attenuated enclosures protect the units against the elements while substantially reducing noise.

STANDARD GENERATOR FEATURES

This generator incorporates the following features:

- The unit meets temperature rise standards for Class "F" insulation as defined by NEMA MG1-22.40, NEMA MG1-1.65 and NEMA MG1-1-66.
- The generator system incorporates "thermal overload protection."
- The generator is self-ventilated and drip-proof constructed.

- The voltage waveform deviation, total harmonic content of the AC waveform and "telephone influence factor" have been evaluated and are acceptable according to NEMA MG1-22.
- A state of the art magnetic circuit provides minimal level of waveform distortion and an electro-magnetic interference level which meets accepted requirements for standard AM radio, TV and marine radio telephone applications.

GENERATOR SPECIFICATIONS

Refer to the DATA PLATE on this particular generator for rated watts (kW), rated maximum amperes, rated AC frequency, rated voltage, number of phases and other pertinent information.

ENGINE SPECIFICATIONS

General

TypeDiesel
 Cylinders and Arrangement4, in-line
 Displacement.....2.2 Liter (133 inches³)
 Bore85 mm (3.35 inches)
 Stroke.....96 mm (3.78 inches)
 Compression Ratio21.5 to 1
 Intake AirNaturally Aspirated
 No. of Main Bearings7
 Governed Engine SpeedSee DATA PLATE
 Maximum Horsepower at 1800 rpm35
 Engine Lubrication System
 Type of Oil PumpGear
 Oil FilterFull Flow Cartridge
 Crankcase Oil Capacity8.0 liters (2.1 U.S. gallons)
 Cooling System
 TypePressurized, closed recovery
 Coolant Capacity
 System.....9.3 liters (2.5 U.S. gallons)
 Engine2.8 liters (.74 U.S. gallons)
 Radiator6.5 liters (1.75 U.S. gallons)
 Coolant Flow Per Minute
 At 1800 rpm61 liters (16 U.S. gallons)
 Heat Rejection to Coolant92,400 BTU/hr.
 Cooling FanPusher type
 Diameter of Fan457mm (18 inches)
 Intake Air Flow Required
 60 Hz.85m³/min. (3000 cfm)
 Exhaust System
 60 Hz.6.9 m³/min. (242 cfm)
 Exhaust Temperature at Rated Output595°C (1103°F)
 Engine Electrical System
 DC Alternator Output.....35 amps at 12 volts
 Starter Motor12 volt DC
 Recommended Battery(1) 12 volt, 135 A.H., 4DLT
 Ground Polarity.....Negative (-)

Fuel Consumption

Model	50%	75%	100%	Standby
GR25 at 60 Hz. (gph)	0.7	0.8	1.1	1.5
(liters per hour)	2.6	3.8	4.4	6.2

INSTALLATION

STANDBY ELECTRIC SYSTEM

A standby electric system may be defined as a system in which the generator is used to operate critical electrical loads normally powered by a utility power source when the utility power source fails or is not present.

- If the units are being set up to operate electrical loads in standby system applications, the units may be used up to their rated capacity. If the total electrical power demanded by all loads in a system is greater than the rated limit, only power essential or key loads (up to the stated capacity).
- Generac does not recommend installing or operating a trailer mounted generator indoors. Other units are available which are better suited for indoor installations.
- A double throw transfer switch is required in standby electric system applications to prevent electrical feedback between the generator and the utility power circuit.
- Figure 1 illustrates a typical standby electric system. Figure 2 shows a schematic diagram of such a system. The transfer switch is used to select which power supply (generator or utility) will operate load circuits in such a system. The transfer switch also prevents load circuits from being connected to both power supplies at the same time.
- If the installer has not installed a transfer switch and modified the electric system as shown in Figure 2, plug critical electrical devices (furnace, fan, sump pump, water pump, etc.) directly into one of the generator's output receptacles.

- If the electrician has installed a transfer switch and a connection box, use a suitable, approved cord set between the connection box and a suitable generator receptacle, or between the connection box and the generator's full capacity terminal studs.



DANGER: If existing electrical circuits in a building are normally powered by the utility source, the installer must provide a positive means of making sure that both power supplies never feed to the load circuits at the same time.

- Never connect the generator output to any live building circuits. If the generator is connected to any existing electrical circuit during a commercial power outage, a positive method of isolating the two power supplies must be provided. The usual method of isolating the circuits is by means of a double throw transfer switch.

Figure 2 - Simple Standby Electric System

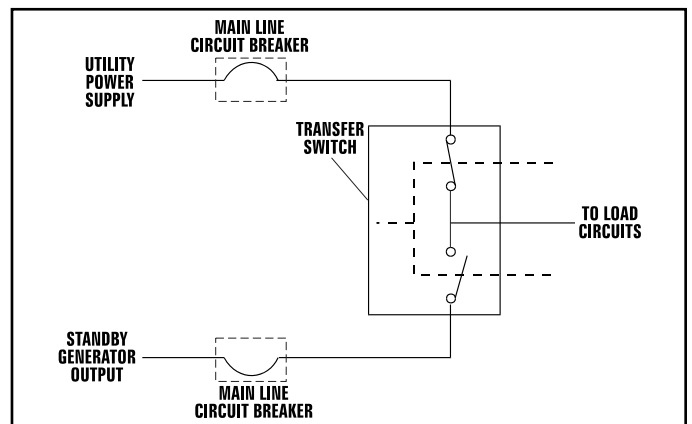
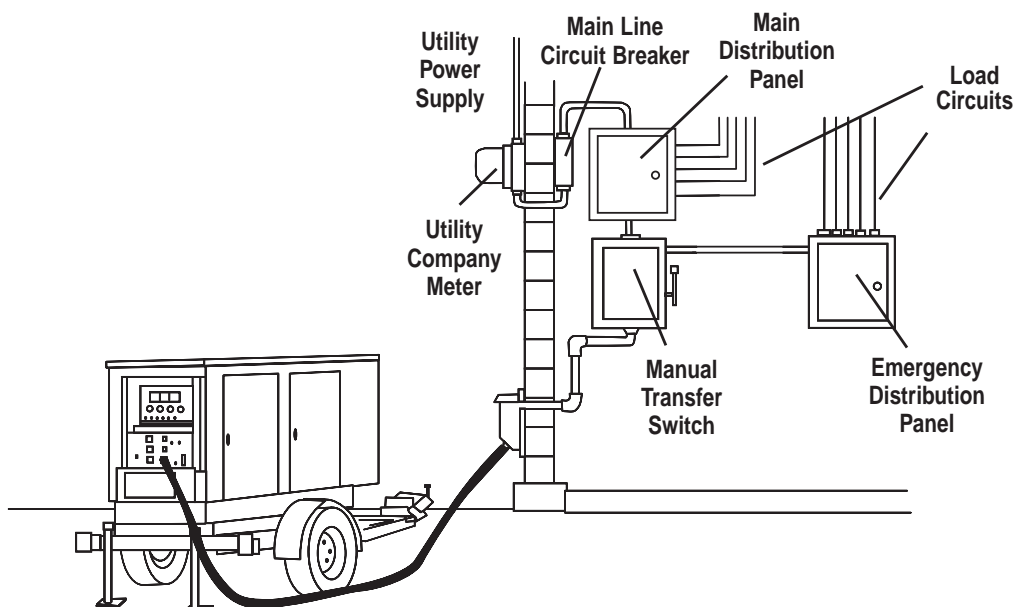

Figure 1 - Typical Standby Electric System





DANGER! A hazard exists during a power outage if the generator is connected to building circuits and no method of positively isolating the generator from the utility supply is provided.



Power company workers attempting to restore utility power will open a switch between the main power supply and the spot where they are working. If the home or building electrical circuits are not isolated from the utility supply, generator AC output will backfeed through the building electrical circuits and up the power line. A power company worker could be electrocuted.



If utility and generator power are not isolated and utility power is suddenly restored while the generator is powering load circuits, the generator can be severely damaged.

Figure 3 - Emergency Circuit Isolation

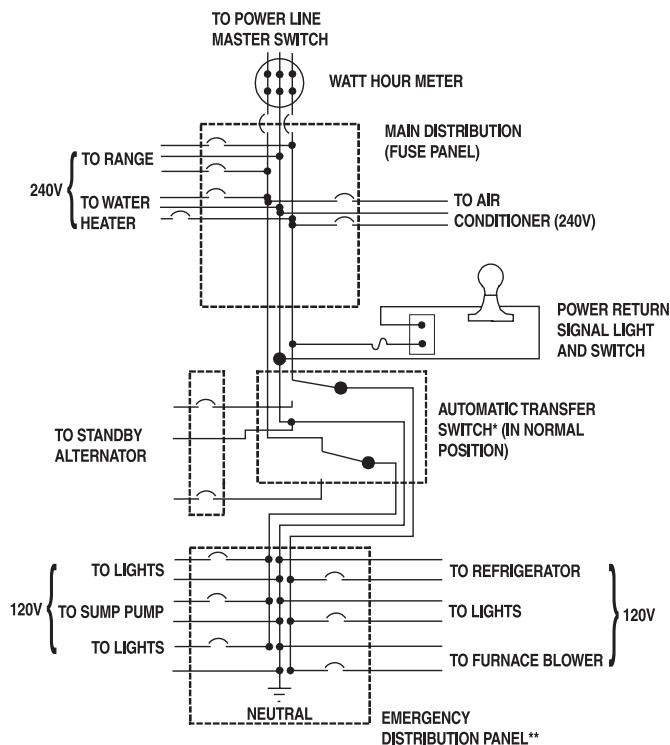

EMERGENCY CIRCUIT ISOLATION

One isolation method is to have emergency circuits (important or essential items to be powered during a utility outage) grouped together and rewired into a separate "emergency distribution panel" (Figure 3). Using this method helps prevent accidental overloading of the generator or the specific generator receptacle in use.

Loads fed by this emergency distribution panel must not exceed the wattage/amperage rating of the generator or the specific receptacle in use.

A transfer switch having an ampere rating equal to, or exceeding, the ampere rating of the emergency circuit should be connected between the building's main electrical distribution panel and the emergency distribution panel.

* Ampere rating must be equal to or exceed the ampere rating of the emergency distribution panels.

** Ampere capacity not to exceed the alternator rating. Only these items will be powered by the standby alternator. If the electrician sizes the load properly, the alternator cannot be overloaded.

All wiring must conform to the United States National Electrical Code (NEC) and all state and local codes. Consult a qualified licensed electrician.

The above illustration assumes the utility is supplying 120/240 volt single phase electric service.

TOTAL CIRCUIT ISOLATION

If the emergency circuits (Figure 4) are not or cannot be wired together in a separate emergency distribution panel, you will have to select the circuits and specific appliances to be powered by the generator during a utility power failure. When this is done, take care to avoid overloading the generator or generator receptacles.

When using the total circuit isolation method, the ampere rating of the transfer switch must equal, or exceed, the rating of the normal incoming utility service.

Figure 4 - Total Circuit Isolation Method

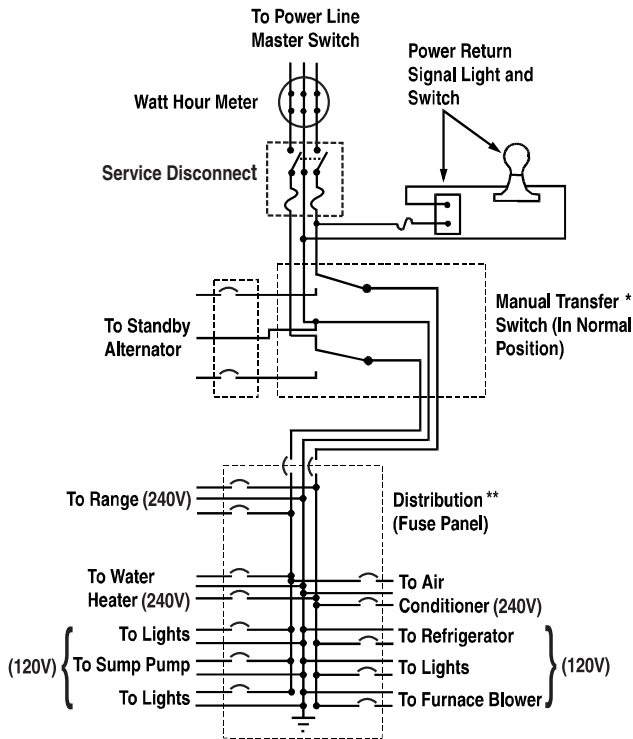

*Ampere rating must be equal to or larger than main (normal) utility entrance service.
 **With this system take care to prevent overloading the alternator. During utility power failure, turn OFF individually all load items to distribution panel. Only certain items can be turned back on during alternator operation. Have an electrician specify these items so the alternator is not overloaded.
 All wiring must conform to the United States National Electrical Code (NEC) and all state and local codes. Consult a qualified licensed electrician.
 The above illustration assumes the utility is supplying 120/240 volt single phase electric service.

PREPARATION BEFORE USE



CAUTION: Prior to initially starting the generator, properly prepare it for use. Any attempt to crank or start the engine before it has been properly serviced with the recommended oil may result in an engine failure. Also, engine coolant level must be checked and replenished if necessary.

ENGINE LUBRICATION

Check engine crankcase oil level prior to use and add oil to the proper level. See "Maintenance" section for recommendations.

ENGINE COOLANT

Check engine coolant level and add the recommended coolant mixture as required. Refer to "Maintenance" section.

FUEL

Fill the 44 gallon base mounted fuel tank with the correct recommended diesel engine fuel. Refer to "Maintenance" section.

NOTE: If the unit has been idle for a long period of time or if fuel lines or fuel system components have been removed and re-installed, the fuel system may require bleeding to remove air from the system. See "Maintenance" section for fuel system bleeding procedures. Air in the fuel system causes hard starting and rough engine operation. All fuel system lines must be installed and must be tight. A loose line may show no sign of leakage, but may draw air into the system.

CORD SETS - 120 VOLT GFCI DUPLEX RECEPTACLE



CAUTION: Panel receptacles can supply only single-phase AC output. Never connect any 3-phase electrical load to a receptacle.

The generator is equipped with a 120 volt ground fault circuit interrupter (GFCI) duplex receptacle on the generator receptacle panel (Figure 5). See "Ground Fault Protection" on Page 14. This outlet consists of a "pair" of receptacles, protected against overload by a 15-amp, push-to-reset type circuit breaker. Thus, use the receptacle pair to power 120 volts, 60 Hz, AC electrical loads requiring up to 15 AC amperes of total current.

Figure 5 - 120 V, GFCI Duplex Outlet

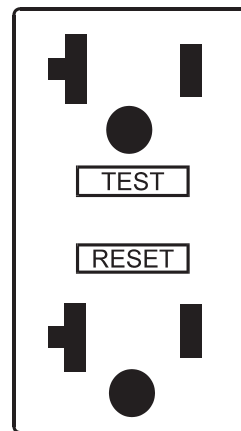

Use only high quality, well-insulated, 3-wire, grounded cord sets with the 120-volt duplex type receptacles. Cord sets should be rated 15 AC amperes at 135 volts or greater.

120 VOLT LOCKING TYPE RECEPTACLE

CAUTION: Panel receptacles can supply only single-phase AC output. Never connect any 3-phase electrical load to a receptacle.

This locking type receptacle (Figure 6) is protected against ground faults with a ground fault circuit interrupter (GFCI) module. See “Ground Fault Protection” on Page 14. It is also protected against overload by a 15-amp, push-to-reset type circuit breaker. The receptacle, a NEMA L5-20R type, requires a mating NEMA L5-20P connector plug. Use only high quality, well-insulated, 3-wire, grounded cord set with connector plug. The cord set must be rated for 15 AC amperes at 135 volts (or greater) electrical loads.

Figure 6 - 120 Volt, Locking Type Receptacle

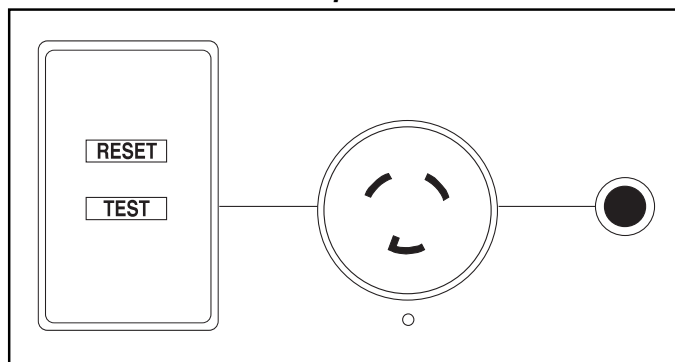

CAUTION: Any attempt to power total loads in excess of 15 amperes from the 120V receptacle pair, or the 120V locking type receptacle, will trip open a circuit breaker, blocking power to either receptacle.

WARNING! Never unplug a connector plug from any panel receptacle while an electrical load is connected and turned on. Conversely, never plug a load in while that load is turned on. Dangerous electrical arcing can occur between the receptacle and the connector plug.

FULL CAPACITY TERMINAL COMPRESSION LUGS

Terminal compression lugs are provided in the two AC power panels (Figure 7). Four terminal studs in one panel are identified as E1, E2, E3, and N (neutral) high voltage connections. The studs for low voltage connections are labeled N (neutral), L3, L2, and L1 in the second panel. These studs may be used to operate either single or three phase electrical loads at up to the full-rated wattage/ampere capacity for each mode of operation (single phase or three phase). Terminal stud AC output is limited by the generator's 90 amp main circuit breaker (CB3) for 208 volts AC loads or the 40 amp main circuit breaker (CB4) for 480 volts AC loads.

Figure 7 - High Voltage Terminal Compression Lugs

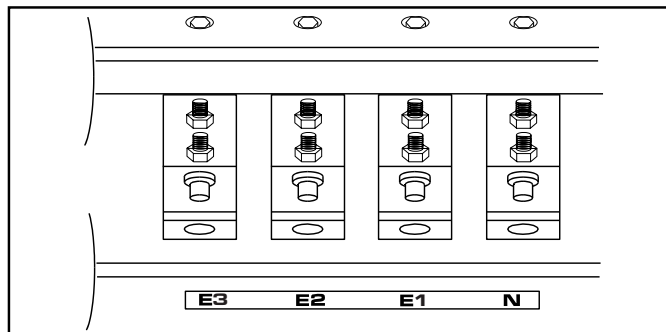

CAUTION: Although you can operate single-phase loads through the terminal lugs as well as the receptacles, DO NOT attempt to connect any three phase loads to the receptacles.

- Wiring cables for connecting loads to terminal studs must be rated 480 volts at 40 AC amperes (or greater) for loads on E1, E2, E3, N and 240 volts at 90 AC amps (or greater) for loads on L1, L2 L3.
- When connecting electrical loads, be sure the voltage adjust dial is positioned to the correct voltage. The dial permits you to adjust the voltage from 120/208 volts and 240/416 volts up to 139/240 volts and 277/480 volts.

CAUTION! Voltage adjust dial affects all receptacles and terminals at the same time.

NOTE:

All receptacles and terminals are available at all times and can be loaded at the same time. **MAXIMUM TOTAL LOAD** must not exceed generator rating. **Maximum load for single-phase or three-phase operation must not exceed the rating for that particular mode of operation (rating for single-phase may be less than for three-phase operation).** The total load connected to any phase, including loads connected to receptacles, must not exceed the rated generator output per phase.

- Set voltage adjust dial to “120/208V” for 120 volts, single-phase or 208 volts, three-phase when connecting for one of these voltages. See “Voltage Adjust Dial” on page 11. Connect cord set leads as follows:
 - L1 to N = 120 volt, single-phase
 - L1 to L2 = 208 volt, three-phase
 - L2 to N = 120 volt, single-phase
 - L2 to L3 = 208 volt, three-phase
 - L3 to N = 120 volt, single-phase
 - L3 to L1 = 208 volt, three-phase
- Set the voltage adjust dial to “139/240V” for 139 volt, single-phase or 240 volt, three-phase when connecting for one of these voltages. See “Voltage

Adjust Dial” on page 11. Then connect cord set leads as follows:

- L1 to N = 139 volt, single-phase
- L1 to L2 = 240 volt, three-phase
- L2 to N = 139 volt, single-phase
- L2 to L3 = 240 volt, three-phase
- L3 to N = 139 volt, single-phase
- L3 to L1 = 240 volt, three-phase

WARNING! With voltage set line-to-line for 240V, line-to-neutral voltage will be 139V at receptacles.

- Set the voltage adjust dial to “240/416V” for 240 volt, single-phase or 416 volt three-phase when connecting for one of these voltages. See “Voltage Adjust Dial” on page 12. Then connect cord set leads as follows:

- E1 to N = 240 volt, single-phase
- E1 to E2 = 416 volt, three-phase
- E2 to N = 240 volt, single-phase
- E2 to E3 = 416 volt, three-phase
- E3 to N = 240 volt, single-phase
- E3 to E1 = 416 volt, three-phase

- Set the voltage adjust switch to “277/480V” for 277 volt, single-phase or 480 volt, three-phase when connecting for one of these voltages. See “Voltage Adjust Dial” on page 11. Then connect cord set leads as follows:

- E1 to N = 277 volt, single-phase
- E1 to E2 = 480 volt, three-phase
- E2 to N = 277 volt, single-phase
- E2 to E3 = 480 volt, three-phase
- E3 to N = 277 volt, single-phase
- E3 to E1 = 480 volt, three-phase

CAUTION: Do NOT connect E1 or E2 or E3 to L1 or L2 or L3. Damage to equipment, personal injury or death may result.

DANGER: Connect cable leads to the power terminal studs only when the engine is shut down. The panel door is equipped with a push-button safety interlock switch (Figure 8) that prevents engine startup and operation while the door is open. Opening the door while engine is running immediately shuts down the engine. The switch is provided for your protection. Do not attempt to bypass or disconnect it.

TRANSFER SWITCH TERMINAL

The AC power panel includes a terminal strip for connecting an automatic transfer switch, such as a GTS transfer switch (Figure 9). This connection allows you to use the unit as a standby generator in practical applications or in emergency situations.

Figure 8 - Interlock Switch on Panel Door

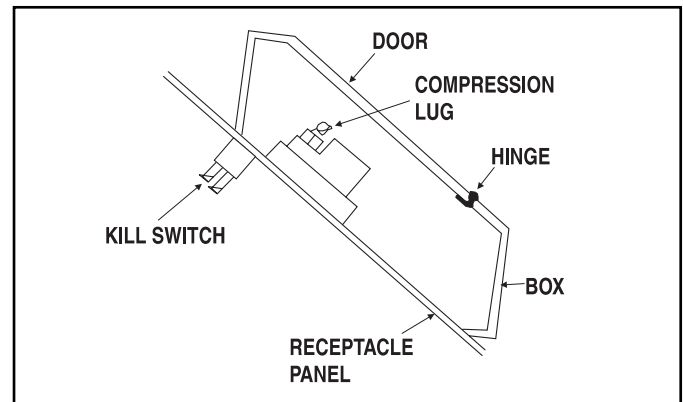
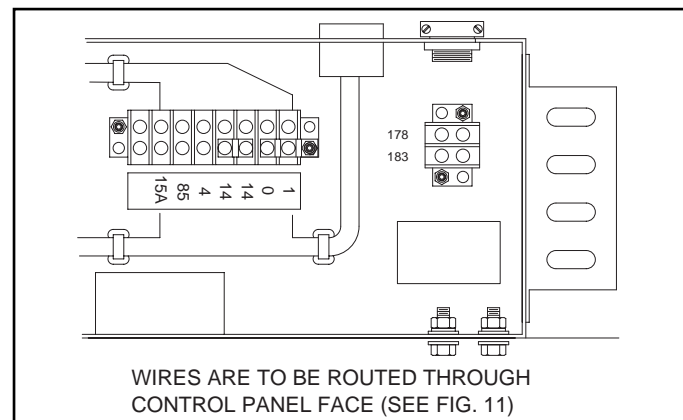

Figure 9 - Transfer Switch Terminals



STARTING BATTERY

This unit requires a 12 volt, Type 90 AH 27F storage battery rated at 90 amp-hours (not included).

- The red battery cable (from starter contactor) should be connected to battery post indicated by a positive POS or (+).
- The black cable (from frame ground) must be connected to the battery post indicated by a negative, NEG or (—).
- The battery must be properly retained in its mounting tray, using the hardware provided.

SWITCHES, METERS AND LIGHTS

For all the components mentioned in this section, refer to Figure 10.

AC VOLTMETER

This AC voltmeter indicates the voltages for generator AC output. Also see "Voltage Adjust Dial" on page 11.

When connecting electrical loads, be sure the voltage adjust dial is positioned to the correct voltage. The voltage adjust dial permits you to adjust voltages from 120/208 volts and 240/416 volts up to 139/240 volts and 277/480 volts.



CAUTION! Voltage adjust dial affects all receptacles at the same time.

NOTE:

All receptacles and terminals are available at all times and can be loaded at the same time. **MAXIMUM TOTAL LOAD** must not exceed generator rating. **Maximum load for single-phase or three-phase operation must not exceed the rating for that particular mode of operation (rating for single-phase may be less than for three-phase operation).** The total load connected to any phase, including loads connected to receptacles, must not exceed the rated generator output per phase.

AC AMMETER

Indicates current draw of connected loads, in amps. Rated maximum continuous load current should be kept within the limits of the rated wattage capacity of the unit for single phase and for three-phase loads.

FREQUENCY METER

Indicates generator AC output frequency in "Hertz" (cycles per second). The generator's rated AC frequency is 60 Hertz, which is supplied at 1800 rpm. The engine governor was factory adjusted at no-load to about 1860 rpm or 62 Hertz. Maximum droop with the generator fully loaded should not be below about 59 Hertz. While operating, normal frequency is between 59-62 Hertz.

NOTE: The engine automatically shuts down and the fault indicator light goes ON if frequency exceeds about 74 Hertz (2220 rpm). This is an "overspeed" condition.

COOLANT TEMPERATURE GAUGE

Indicates engine coolant temperature. Coolant temperature during unit operation is about 170°-200°F. If the coolant temperature exceeds about 250°F, the engine automatically shuts down and the fault indicator light goes ON.

OIL PRESSURE GAUGE

Indicates engine oil pressure.

Figure 10 - Generator Control Console

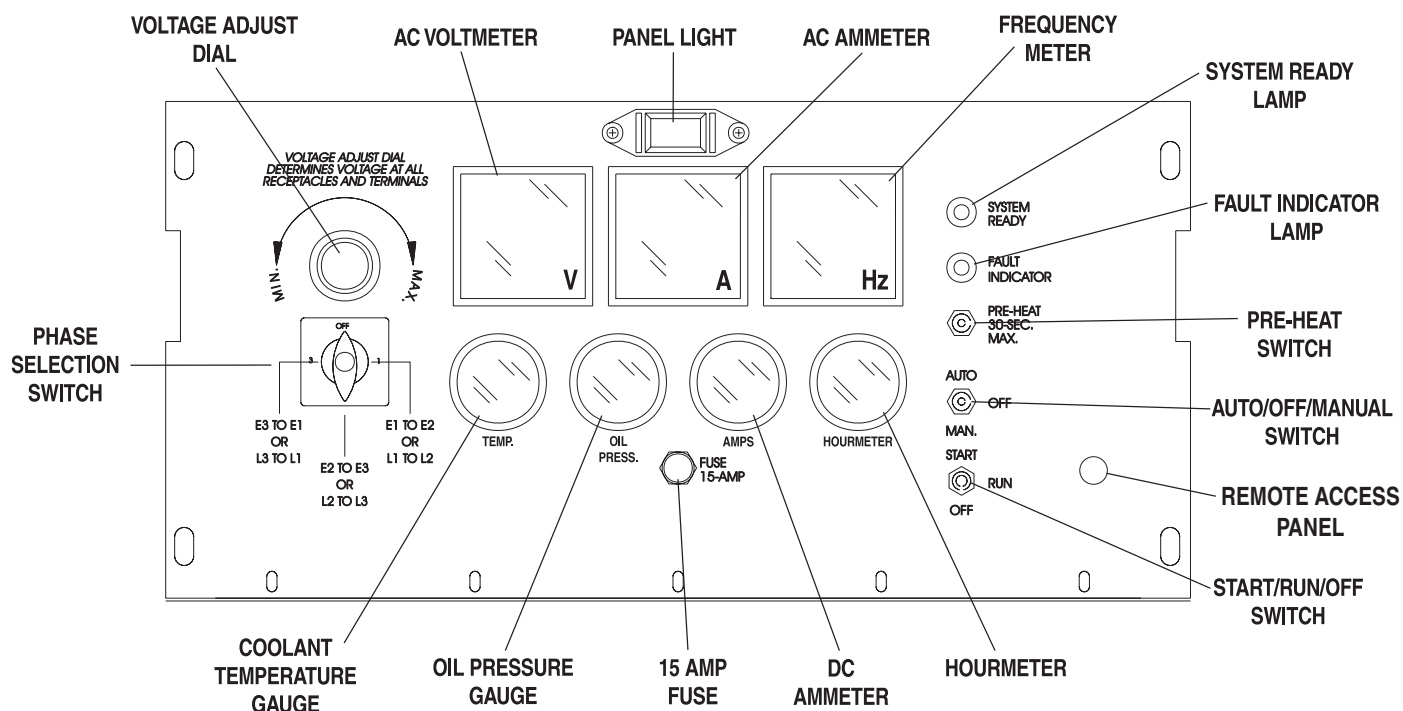

■ DC AMMETER

The engine is equipped with a belt-driven DC alternator which maintains battery state of charge while the unit is running. This ammeter indicates rate of charge to the battery while operating.

- Immediately after startup, the DC ammeter needle may swing to the right of zero (+ - charging) but should drop to zero or just slightly to the right of zero (+) within a few minutes.
- If the needle drops to the left of zero (or —), battery is discharging. Investigate and correct this problem immediately.
- If the ammeter needle fluctuates, investigate and correct immediately. Disconnect battery and control panel fuse prior to working on unit.

■ HOURMETER

Provides a continuous indication of engine-generator operating time, in hours and tenths of hours. Use the hourmeter with the periodic maintenance schedule (See "Maintenance" section).

■ SYSTEM READY LAMP

This lamp goes ON when the unit is running. The lamp will not go ON if a fault has occurred and you have not set the Start/Run/Off switch to OFF to reset.

■ FAULT INDICATOR

This lamp goes on if any one or more of the following automatic shutdown faults occurs:

- High coolant temperature (above about 250°F).
- Low coolant level.
- Low engine oil pressure (below 10 psi).
- Overspeed above about 74 Hz (2220 rpm).
- Overcrank

■ PRE-HEAT SWITCH

This engine comes with GLOW PLUGS to heat the combustion chamber air for quicker and easier starts. Prior to starting a cold engine manually, hold the PRE-HEAT switch for about 15 seconds. DO NOT PREHEAT FOR MORE THAN 30 SECONDS.

■ AUTO/OFF/MANUAL SWITCH

This safety switch should be used to prevent automatic startup of the engine when working on the engine-generator. Use the switch as follows:

- AUTO Position: Always set switch to AUTO for automatic system operation. This means when this generator is installed along with a GTS type automatic transfer switch, the generator automatically cranks and starts when the utility source voltage drops below a preset level.

- OFF Position: Engine cannot be started either automatically or manually. Always set switch to OFF before working on or around the engine-generator.
- MANUAL Position: Engine can be cranked and started manually using the panel Start/Run/Off switch. Engine will not start automatically.

■ START/RUN/OFF SWITCH

To crank and start the engine, hold the Start/Run/Off switch at "Start". When engine starts and runs at rated frequency, release the switch to its center (Run) position. To shut engine down, set the switch to the "Off" position.

■ PANEL LIGHT

The panel light will turn on when the unit is running or cranking.

■ VOLTAGE ADJUST DIAL

This potentiometer permits the operator to select the desired output voltage from the alternator. Turning the voltage adjust dial counterclockwise decreases the voltage and allows operation of loads down to 120/208 volts AC and 240/416 volts AC and a little below.

Turning the dial clockwise, the unit can operate up to 139/240 volts and 277/480 volts AC and slightly higher voltages. The generator can power any load with voltage between these two extremes including 127/220 volts AC near the center of the dial.

Note: The voltage indicated on the voltage adjust dial is line-to-line voltage (See "Voltage Code X" on page 4).



CAUTION! Voltage adjust dial affects all receptacles at the same time.

NOTE:

All receptacles and terminals are available at all times and can be loaded at the same time. MAXIMUM TOTAL LOAD must not exceed generator rating. Maximum load for single-phase or three-phase operation must not exceed the rating for that particular mode of operation (rating for single-phase may be less than for three-phase operation). The total load connected to any phase, including loads connected to receptacles, must not exceed the rated generator output per phase.

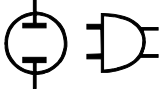

■ PHASE SELECTION SWITCH

This switch permits you to select the phases for which the line-to-line voltage and amperage readings are displayed on the console AC voltmeter and ammeter.

ENGINE PROTECTIVE DEVICES

Unlike an automobile, the generator may be required to run for long periods without an operator nearby to monitor engine parameters (oil pressure, temperature, engine speed, etc.). For that reason, the unit is equipped with various protective devices which will stop the engine automatically if an operational fault occurs.

■ LOW OIL PRESSURE SWITCH

This normally-closed, pressure actuated switch (Figure 11) is held open by engine oil pressure during running. Should engine oil pressure drop below about 10 PSI, the switch contacts will close. When contacts close, the engine automatically shuts down and the fault indicator lamp goes ON.

Figure 11 - Low Oil Pressure Switch

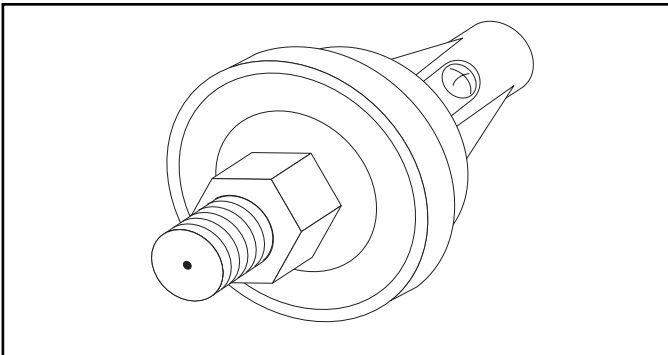

■ HIGH COOLANT TEMPERATURE SWITCH

This thermostatic, normally-open switch (Figure 12), is immersed in engine coolant. Should coolant temperature increase above about 250°F, the switch contacts close and an automatic shutdown occurs.

Figure 12 - High Coolant Temperature Switch

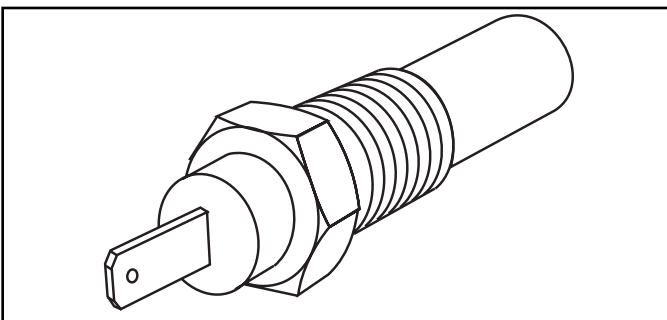

■ LOW COOLANT LEVEL SENSOR

If engine coolant level is low, a high temperature condition can exist without affecting the high coolant temperature switch. However, the low coolant level sensor (Figure 13) will detect the low level condition and initiate an engine shutdown.

Figure 13 - Low Coolant Level Sensor

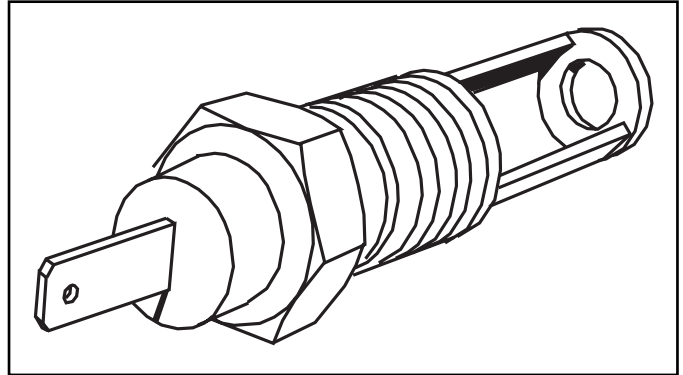

■ DC CONTROL/LATCH-CRANK CIRCUIT BOARD

The circuit board, housed inside the generator control console, controls engine starting, running and shutdown. The board provides either manual (electric) or automatic starting. It senses the generator is running by means of generator AC output.

■ ENGINE STARTUP

When the engine starts, the starter is disabled when AC output reaches about 40 volts AC (rms). Engine speed at that point has reached between 1000 to 1250 rpm.

A nominal five second time delay after starter cutout is provided. That is, if any one or more of the shutdown faults (low oil pressure, high coolant temperature, low coolant level, etc.) occurs five seconds or more after the starter cutout has occurred, the engine shuts down and the fault indicator lamp goes ON after the fault has been maintained for two seconds.

■ AFTER FAULT SHUTDOWN

The engine cannot start until the engine control is reset, following an automatic fault shutdown with the fault lamp ON. Reset the control by setting the Start/Run/Off switch to "Off" and then back to "Start".

■ OVERSPEED

A speed circuit controls engine cranking, start-up, operation and shutdown. Engine speed signals are delivered to the circuit board whenever the unit is running. Should the engine overspeed above a safe, preset value, the circuit board initiates an automatic engine shutdown and the fault indicator lamp goes on.

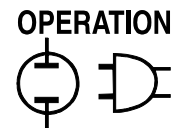

OVERCRANK SHUTDOWN

If the engine fails to start after a crank cycle of 90 seconds (eight seconds on, eight seconds off), this function will illuminate the fault indicator and stop the crank cycle.

OPERATING INSTRUCTIONS

BEFORE STARTING

- Prior to starting the engine, make sure the engine-generator has been properly prepared for operation as outlined in PREPARATION BEFORE USE (Pages 7-10).
- Check that both of the power panel (compression lug) doors are closed and latched. Engine will not start if any power panel door is open (Figure 9 on page 9).
- Check that the Voltage Adjust Dial is adjusted for the proper voltage that your loads require.

STARTING THE ENGINE

- Be sure all necessary cables are connected to the full capacity compression lugs before starting the engine (see pages 8-9). ALL electrical loads must be switched off before starting the engine (including loads connected to the receptacle panel).
- Place the Auto/Off/Manual switch in “Manual” position.
- Crank the unit by moving the Start/Run/Off switch to “Start”.
- When engine starts and runs at rated Hertz, release the start switch to the “Run” position.
- Let the engine stabilize and warm up for a few minutes. Then turn on the desired electrical loads.

NOTE:

During starting, the fault indicator lamp remains ON until oil pressure builds. If any monitored shutdown occurs, you cannot restart the engine until you reset the controls. To do this, set the Start/Run/Off switch to “Off” and then back to “Start”.

SHUT DOWN

- Turn all loads OFF.
- Let the engine run at no-load for a few minutes to stabilize internal engine temperatures.
- On the generator control console, set the Start/Run/Off switch to “Off”. Wait for the engine to come to complete stop.

OPERATION IN ICE OR SNOW

If the generator has been exposed to freezing rain or snow, be sure to inspect the air inlet and outlet areas in the compartment. Do not operate the unit if snow or ice have blocked or obstructed the air openings.

The generator is equipped with a “pusher” type cooling fan. This type of cooling fan draws air into the generator, then expels the air outward through the engine radiator. If cooling air flow is obstructed, the engine-generator may overheat.

GROUNDING THE GENERATOR

The National Electric Code (NEC) requires that the frame and external electrically conductive parts of the generator be properly connected to an approved earth ground. Local electrical codes may also require that you ground the unit. Consult with a local electrician for grounding requirements in your area.

Grounding helps prevent dangerous electrical shock if a ground fault exists in the generator or connected electrical devices. Grounding also helps dissipate static electricity that often builds up in ungrounded devices. Static electricity alone can cause very painful shock and may cause one to believe that a shorted condition exists in equipment.

GROUND FAULT PROTECTION

The generator is equipped with a 120 volt duplex receptacle, and a 120V locking type receptacle. Each of these receptacles incorporates a Ground Fault Circuit Interrupter (GFCI) rated at 20 amps. These devices meet standards with applicable federal, state and local codes.

The GFCI protects against electrical shock that may be caused if the body becomes a path through which electricity travels to reach ground. This could happen if one touches an appliance or cord that is “live.” One doesn’t even have to be on the ground, one could be touching plumbing or other material that leads to ground.

When protected by a GFCI, a person will still feel a shock, but the GFCI should cut it off quickly enough so a person in normal health should not have a serious electrical injury (Children can still be affected).

 **WARNING! THE GFCI WILL NOT PROTECT AGAINST THE FOLLOWING SITUATIONS: (1) LINE-TO-LINE SHOCKS (such as shocks from touching metal in both straight slots of an outlet); (2) CURRENT OVERLOADS OR LINE-TO-LINE SHORT CIRCUITS. THE FUSE OR CIRCUIT BREAKER AT THE DISTRIBUTION PANEL MUST PROVIDE SUCH PROTECTION.**

Testing the GFCI: Test the GFCI outlets every month. Follow these instructions:

1. Push the black TEST button. The red RESET button should pop out from the inner surface, which should allow no power to reach the outlet. Use a test lamp in each outlet.

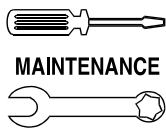

MAINTENANCE

Maintenance

GR-25 Generator Set



CAUTION! If RESET button does not pop out, or test lamp remains lit when RESET button does pop out, DO NOT USE ANY OUTLETS ON THE CIRCUIT. CALL A QUALIFIED ELECTRICIAN.

2. If the GFCI tests good, restore power by pressing the RED RESET button. THE RESET BUTTON MUST BE PUSHED FIRMLY AND FULLY INTO PLACE UNTIL IT LOCKS AND REMAINS IN THAT POSITION. IF THE GFCI DOES NOT RESET PROPERLY, DO NOT USE THE OUTLET — CALL A QUALIFIED ELECTRICIAN. Test lamp should go ON.
3. If the GFCI trips by itself at any time during or after installation, reset and perform steps 1 and 2. IF RESET BUTTON DOES NOT POP OUT WHEN TEST BUTTON IS PRESSED, DO NOT USE THE OUTLET. CALL A QUALIFIED ELECTRICIAN.

NOTE: Each 120 volt receptacle is protected with a 15 amp circuit breaker. The maximum total current from each receptacle is limited to 15 amps (See “Cord Sets - 120 Volt GFCI Duplex Receptacle”, and “120 Volt Locking Type Receptacle”).

MAINTENANCE

It is the owner's responsibility to perform all safety checks; to verify all required maintenance is performed for safe operation; and to have the equipment checked periodically by an authorized service technician. Normal maintenance service and replacement of parts are the responsibility of the owner/operator and, as such, are not considered defects in workmanship or material under the terms of the warranty.

Individual operating habits and equipment usage contribute to the need for maintenance service. Proper maintenance and care of your generator will help keep the number of problems and overall operating expenses at a minimum. See an authorized Generac Power Systems dealer/distributor or contact the factory for service aids.

100-HOUR BREAK IN

The first 100 hours is the break in period. Correctly breaking in the engine-generator is essential to minimize oil consumption and maximize engine performance. During break in, observe the following rules.

- For the 100 hours of operation, avoid light electrical loads. Load the unit at 50% or more of its capacity during this period. Repeated light loads during break in can cause improper seating of the engine piston rings, resulting in blowby and high oil consumption after prescribed break in period.
- Check engine oil level frequently during break in. It is normal for oil consumption to be higher than normal during this period.
- After the 100-hour break in, complete the tasks recommended under “100-Hour Break In Period”.

- If continuous light loads are applied to unit during break in period, run unit for another 100 hour break in period with the recommended engine oil.

100-HOUR BREAK IN PERIOD

After the first 100 hours of operation, contact an authorized service facility for the following maintenance. The generator owner is responsible for all charges.

- Change engine oil and filter.
- Check all fluid levels.
- During break in, don't add oil until level is at the bottom of the crosshatching on dip stick.
- Inspect cooling system hoses for leaks, loose or defective clamps, and for damage or deterioration.
- Check the fuel system for leaks, condition, and tightness of fuel lines.
- Check the engine for proper operation.
- Check generator AC output. Make sure voltage and frequency are correct.
- Check the unit battery for proper electrolyte fluid level, proper state of charge, and condition.
- With engine running, note readings of all gauges and instruments.

RECOMMENDED ENGINE FLUIDS

ENGINE OIL & OIL LEVEL

The quality of engine oil may largely affect engine performance, startability and engine life. Use of unsuitable engine oil will result in piston ring, piston and cylinder seizure and accelerate the sliding surface wear causing increased oil consumption, lowered output and, finally engine failure. To avoid this, use the specified engine oil.

Engine Oil Selection: 4LB1, 4LC1, 4LE1—API, CC or CD grade.

Oil Viscosity: Engine oil viscosity largely affect startability, performance, oil consumption, speed of wearing and occurrence of seizure, etc. Using lubricants whose viscosity selected according to the atmospheric temperature is important.

Note:

Using a mixture of different brand or quality oils will adversely affect the original oil quality; therefore, never mix up different brand or different type oils. Don't use API, CA, CB grade and reconstituted engine oil. Engine damage due to improper maintenance, or using oil of the improper quality and/or viscosity, is not covered by the warranty.

Consider the ambient temperature when selecting the viscosity of lubricating oil for your engine. Use the chart on the next page to determine the oil you use.



AMBIENT TEMPERATURE	OIL RECOMMENDATION
-40° to 30°C (-40° to 86°F)	SAE 0W-30
-25° to 15°C (-13° to 59°F)	SAE 5W-20
-20° to 30°C (-4° to 86°F)	SAE 10W-30
-15° to 50°C (5° to 122°F)	SAE 15W-40
0° to 30°C (32° to 86°F)	SAE 30
25° to 50°C (77° to 122°F)	SAE 40
API Service Certification	CG-4 or CF-4

NOTE:

Multi-viscosity diesel engine oils are preferred. If diesel fuel with sulfur content greater than 0.5% is used, reduce the service interval by 50%.

Check engine oil level at least once daily (prior to use) or at least every eight hours of operation, whichever comes first. The following rules apply:

- When checking oil level, the generator should be sitting on a level surface.
- Always check oil level BEFORE starting the engine, or wait at least 30 minutes after the engine is shut down.
- Avoid mixing different brands or different types of oil.
- The higher pressures and hotter temperatures in a diesel engine require that you use only Class CF-4 or CG-4 oil.
- Never operate the engine with oil below the cross-hatching on dipstick.
- Never overfill the engine crankcase above the dipstick crosshatching.
- To check oil level, remove dipstick and wipe dry with a clean cloth. Then, re-insert dipstick into dipstick tube and remove again. Oil should be between the top of the crosshatching and "ADD" marks. Add oil as required.

ENGINE COOLANT

The use of coolant products is strongly recommended.

Coolant products to use are silicate ethylene glycol base coolants for heavy-duty diesel engines. Use when mixed with quality water and supplemental coolant additives (SCAs), if they meet the following specifications:

- ASTM D5345 (prediluted coolant)
- ASTM D4985 (coolant concentrate) in a 40% to 60% mixture of concentrate with quality water.

Coolants meeting these specifications require addition of supplemental coolant additives (SCAs), formulated for heavy-duty diesel engines.

IMPORTANT:

Never use automotive-type coolants (such as those meeting ASTM D3306 or ASTM D4656). These coolants do not contain the correct additives to protect heavy-duty diesel engines. They often contain a high concentration of silicates and may damage the engine or cooling system.

IMPORTANT:

DO NOT over-inhibit antifreeze solutions, as this can cause silicate-dropout. When this happens, a gel-type deposit is created which retards heat transfer and coolant flow causing engine to overheat. Check inhibitors between drain intervals (every 600 hours or 12 months) of operation. Replenish inhibitors by the addition of a supplemental coolant additive as necessary. DO NOT use soluble oil and an antifreeze-coolant mix with a non-chromate inhibitor.

Operating without the proper coolant additive will result in increased corrosion, cylinder liner erosion and pitting, and other damage to the engine and cooling system. A simple mixture of ethylene glycol and water WILL NOT give adequate protection.

These chemicals reduce the number of vapor bubbles in the coolant and help form a protective film on cylinder liner surfaces. This film acts as a barrier against the harmful effects of collapsing vapor bubbles.

Test the coolant solution at 600 hours or 12 month intervals and whenever excessive coolant is lost through leaks or overheating to ensure the necessary protection. If coolant level in radiator or recovery bottle is low, proceed as follows:

- Inspect the radiator cap gasket for wear or damage. Replace cap, if necessary.
- Have the radiator pressure cap tested at an automotive repair facility or at an authorized Generac service facility.
- Check cooling system hoses and radiator for leaks.

NOTE:

When working properly, the coolant recovery system keeps the radiator coolant at the proper level. The radiator cap is equipped with both a pressure relief and a vacuum relief valve. When hot radiator coolant expands, excess coolant opens the pressure relief valve and drains into the coolant recovery bottle. After shutdown, as coolant mixture in the radiator cools, it contracts to form a vacuum. The vacuum relief valve then opens, to draw coolant from the recovery bottle and return it to the radiator. The coolant recovery bottle must be kept filled to the proper level to maintain radiator coolant at the proper level.

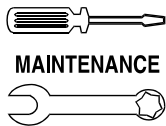

Maintenance

GR-25 Generator Set

■ FUEL

Check fuel quantity at least once daily (every eight hours) and prior to use. The base-mounted fuel tank is equipped with a float operated fuel level gauge. Fill tank when level is between half full and 1/4 full. Use clean, fresh, No. 2D diesel fuel having a minimum Cetane Number "40" and conforming to ASTM* specifications.

*ASTM — American Society of Testing and Materials

IMPORTANT:

NEVER PERMIT THE ENGINE TO RUN OUT OF FUEL. IF ENGINE RUNS OUT OF FUEL OR IF FUEL LEVEL IN TANK DROPS TOO LOW, AIR WILL ENTER FUEL SYSTEM LINES AND CAUSE SERIOUS PROBLEMS, SUCH AS HARD STARTING AND ROUGH, ERRATIC OPERATION. YOU MUST BLEED THE ENGINE FUEL SYSTEM WHEN IT RUNS OUT OF FUEL.

OWNER/OPERATOR PERIODIC MAINTENANCE

Some maintenance tasks may be beyond the capability of the owner/operator and should be done by a competent, qualified service technician. The owner/operator may can do the following:

- Check the engine oil level once daily; more often during the 100-hour break in period.
- Check the tire pressure before using and at least once each week thereafter. Keep the tires properly inflated according to tire specifications.
- Inspect entire fuel system once each month. Look for leaks, damage, loose lines, etc.
- Inspect engine drive belts prior to initial use and once each month thereafter. Replace any belt that is worn, cracked weathered, or otherwise damaged. Check and adjust belt tension. Consider tension correct when applying thumb pressure midway between pulleys causes a belt deflection of about 3/8 to 3/4 inch.
- Check battery electrolyte fluid level once each week. Add distilled water, if needed. Also inspect battery posts, cables and terminals for tightness, cleanliness, corrosion. Clean and tighten as required.
- Drain water and sediment from the optional spin-on fuel filter once each week (if so equipped).
- Start and exercise the unit at least once each week. Run the engine for at least 30 minutes during this exercise period.
- Keep the unit clean and as dry as possible. Use a mild detergent and water to clean exterior surfaces. Areas with paint damage should be cleaned, dried and repainted as necessary. An automotive type of paint may be used on the outside of the compartment.

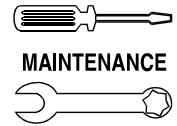

BLEEDING THE FUEL SYSTEM

The fuel system for this engine has a self-bleeding function, so air should not enter the fuel lines unless the engine has been disassembled for any reason. Bleeding air from the fuel system involves manually actuating the fuel lift pump.

PERIODIC MAINTENANCE LIST

The following maintenance tasks should be performed by an authorized service facility at these periodic intervals.

DAILY

- Check engine oil and coolant level.
- Check air cleaner dust valve & restriction indicator, replace filter (as required).
- Visual Walk around inspection.
- Inspect AC power cables and cord sets.

EVERY 50 HOURS OR 2 WEEKS

- Check fuel filter.

EVERY 250 HOURS OR 6 MONTHS

- Check battery state-of-charge and condition, service as necessary.
- Change engine oil and replace filter.**

**Change the oil for the first time after 100 hours maximum of (break-in) operation, then every 250 hours thereafter.

EVERY 600 HOURS OR 12 MONTHS

- Clean crankcase vent tube.
- Check air intake hoses, connections & system.
- Replace spin-on fuel filters.
- Check automatic belt tensioner and belt wear.
- Check cooling system.
- Coolant Solution analysis-add SCAs as needed.

EVERY 1200 HOURS OR 24 MONTHS

- Adjust droop on generator set engine.
- Pressure test cooling system.
- Flush cooling system.
- Check operation of engine protective devices (low oil pressure, high coolant temperature, overspeed).

EVERY 2000 HOURS*

- Check and adjust engine valve clearance.
 - Retorque engine intake manifold bolts.
 - Retorque engine exhaust manifold bolts.
 - Check injection timing.
 - Check/inspect injection nozzles.
 - Check engine compression pressure.
- *See Engine Manual for proper information.

ADJUSTMENT OF FUEL INJECTION TIMING

A diesel engine does not have an electrical ignition system like those used on gaseous or gasoline-fueled engines. The diesel fuel is ignited by the heat of compression when the piston moves upward on its compression stroke. The engine firing is timed by precisely timing the injection of fuel into each cylinder at the proper moment. If the unit's injection system appears to be "out of time," have the engine checked and adjusted by an authorized diesel engine service facility. Do not attempt to adjust ignition timing without proper tools, test equipment and general knowledge of the product.

ENGINE SPEED ADJUSTMENT

The engine speed is controlled either with a mechanical governor or electronically.

The mechanical, fixed speed governor is part of the fuel injection pump. The governor was factory set to maintain 62 Hertz (1860 RPM) with no electrical loads applied. Under full rated wattage/amperage capacity, frequency may droop to about 59-60 Hertz.

The electronic governor has a solid-state design for the controller circuit board and actuator. This design results in fast, stable engine response to load changes. The controller board was factory set to maintain the unit's rated speed of 1800 rpm to achieve a frequency of 60 Hertz.

If the engine speed controller on the generator needs adjusting, contact an authorized service facility. They will have the proper equipment and trained personnel to complete all necessary adjustments.

****Contact your nearest Generac/Guardian Authorized Dealer for assistance.**

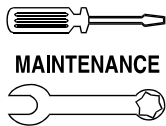

MAINTENANCE

Maintenance

GR-25 Generator Set



WARNING! Do not adjust the engine governed speed without proper equipment and know-how. The governed speed was factory set and should require no additional adjustment. Excessively high speeds are dangerous and increase the risk of personal injury or damage to equipment and/or property. Correct AC frequency and voltage are supplied only at the correct governed speed. Some connected electrical devices are extremely sensitive to frequency and voltage, and may be damaged by incorrect frequency and/or voltage. Operation of the unit at excessively low speeds imposes a heavy load on the engine when sufficient engine power is not available and may shorten engine life.

NOTE:

Generally, if AC frequency and voltage are both correspondingly high or low, the engine governor requires adjustment. If AC frequency is correct but voltage is not, the voltage regulator requires adjustment or some other problem exists.

VOLTAGE REGULATOR ADJUSTMENT

The generator's AC voltage regulator has been factory set to allow an operator to select proper voltage via the voltage adjust dial. If the voltage regulator on the generator needs adjusting, contact an authorized service facility. Only qualified service technicians should adjust voltage regulators.

GENERATOR ROTOR BEARING

The generator rotor is attached to the engine drive shaft at one end. The opposite end of the rotor rides in a pre-lubricated and sealed ball bearing that requires no additional lubrication for the life of the bearing.

MAJOR REPAIRS

Proper and regular maintenance of the generator is needed to make sure the generator has a long and trouble-free life. Only a qualified, competent generator service technician should perform all major generator service, including installation and replacement of factory approved repair parts. Only qualified, competent diesel engine repair facilities should service the engine, using only factory approved parts.

This section or your OWNER'S MANUAL consists of EXPLODED VIEWS pertaining to the generator and its engine, along with PARTS LISTS for the EXPLODED VIEWS. The PARTS LISTS consist of (a) an item number, (b) quantity required, (c) a part number and (d) a description of the part. The ITEM NUMBER relates to an identical number in the EXPLODED VIEW.

HOW TO ORDER PARTS

To order a replacement part, locate the part in the applicable EXPLODED VIEW in this manual. Provide the dealer/distributor with the following information:

- Generator BUILD NUMBER (from the unit data plate).
- Part NUMBER and DESCRIPTION (from the applicable PARTS LIST in this manual).
- The applicable exploded view DRAWING NUMBER.

Electrical Data
GR-25 Generator Set

Wiring Diagram – Control Panel – Drawing No. 090118-B

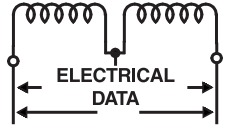

- AM – AMMETER, AC
- BCA – AMMETER, BATTERY CHARGER
- CBI – CIRCUIT BREAKER – FIELD
- D1 – DIODE 600V 12 AMP
- EC – ENGINE CONTROL
- F1 – FUSE 15 AMP
- G1 – GAUGE, WATER TEMPERATURE
- G2 – GAUGE, OIL PRESSURE
- HM – HOURMETER
- HZ – FREQUENCY METER
- L1 – LAMP, FAULT
- L2 – LAMP, PANEL
- L3 – LAMP, RUN
- PHR – PREHEAT RELAY
- RT – POTENTIOMETER, VOLTAGE ADJUST
- D2 – RECTIFIER 800V 2A
- R3 – RESISTOR – ENG. ALTERNATOR
- R4 – RESISTOR, FIELD BOOST
- SW2 – SWITCH, START/RUN/STOP
- SW3 – SWITCH, PREHEAT
- SW5 – SWITCH, PHASE SELECTOR
- SW6 – SWITCH, AUTO/OFF/MANUAL
- TB – TERMINAL BLOCK
- VM – VOLTMETER, AC
- VR – VOLTAGE REGULATOR

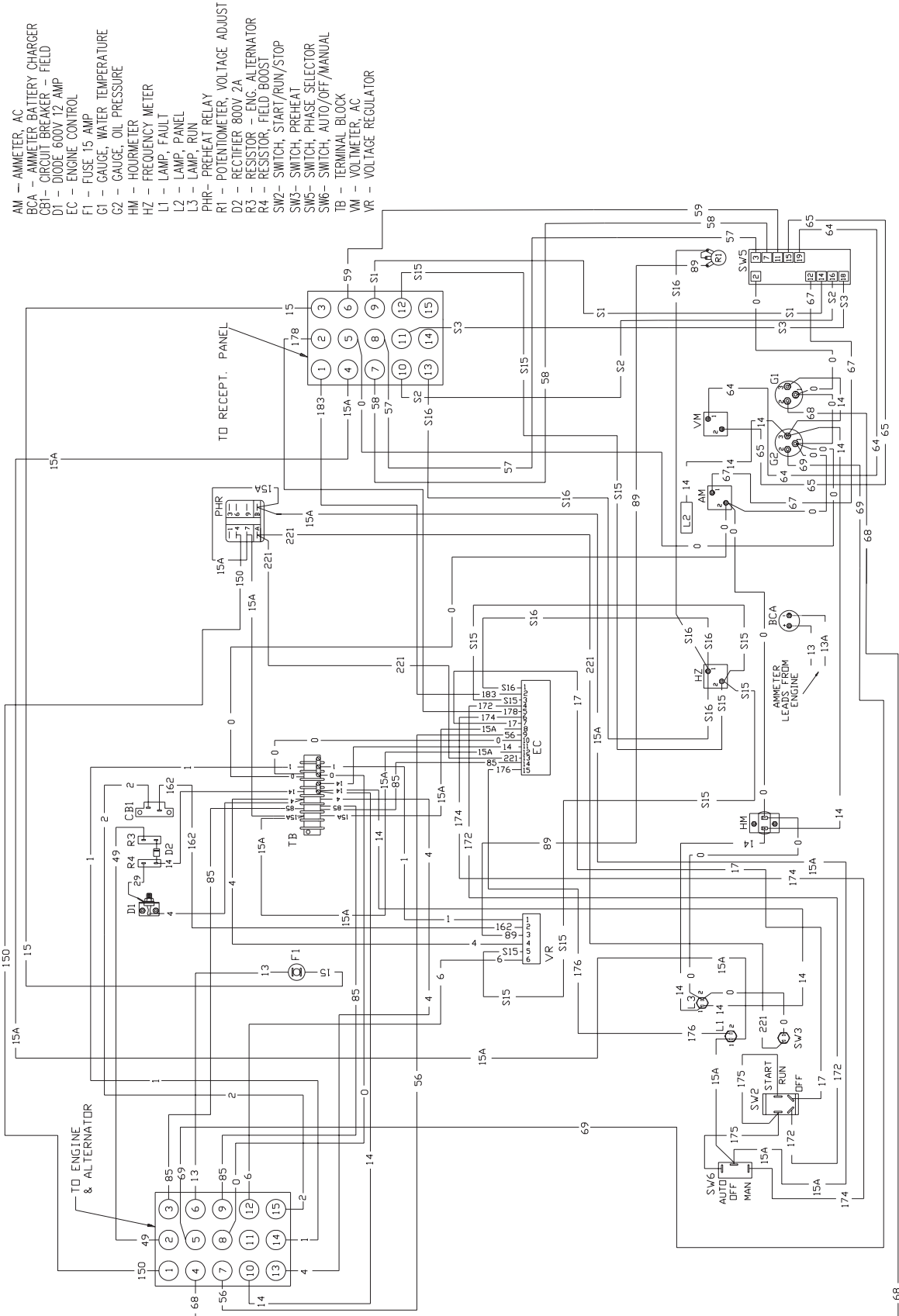

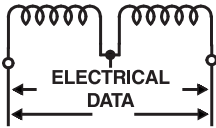

Electrical Data

GR-25 Generator Set

Schematic – Control Panel – Drawing No. 090119-A

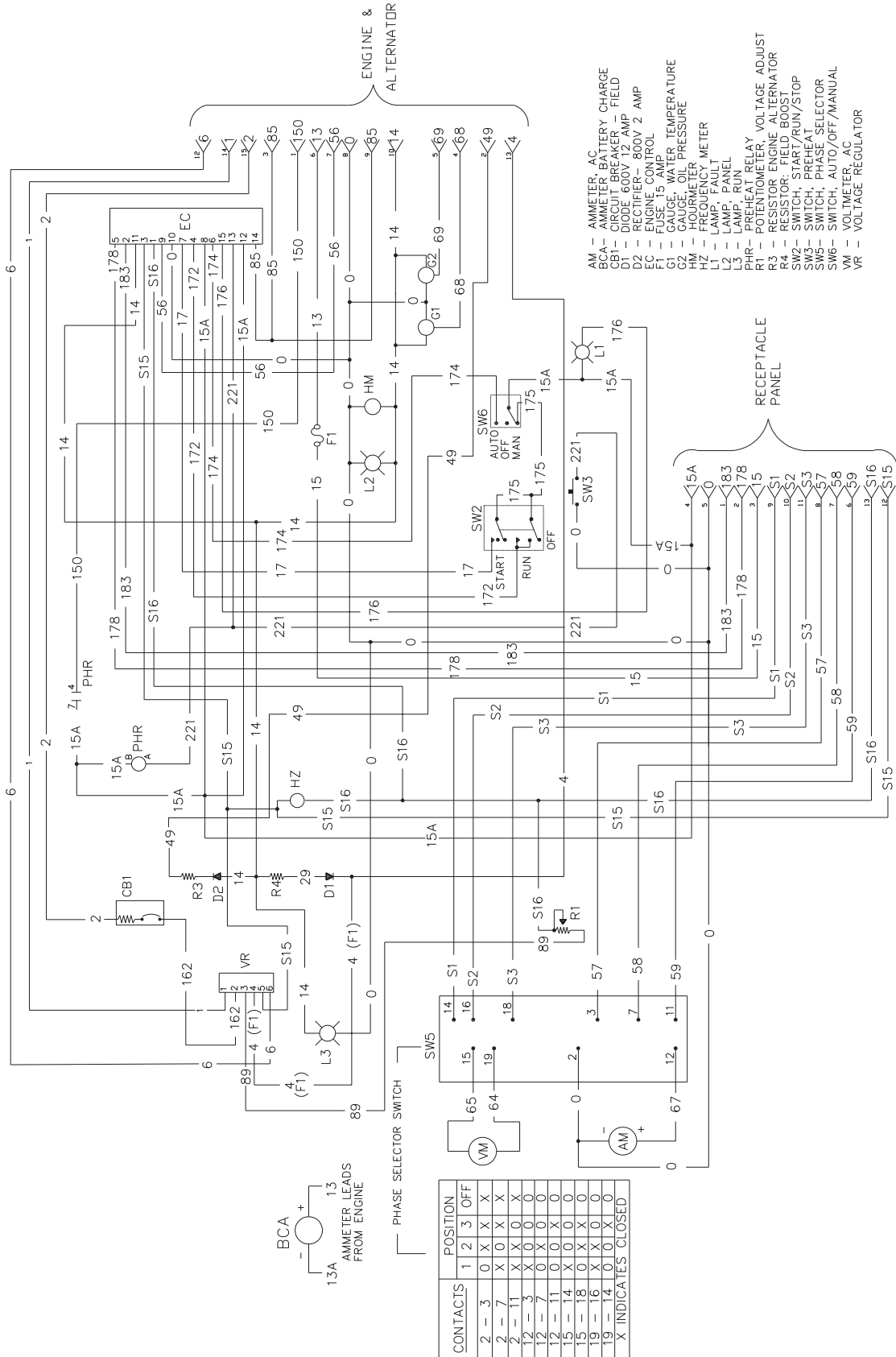

- AM – AMMETER, AC
- BCA – AMMETER, BATTERY CHARGE
- CB1 – CIRCUIT BREAKER – FIELD
- D1 – DIODE 600V 12 AMP
- D2 – RECTIFIER – 800V 2 AMP
- EC – ENGINE CONTROL
- F1 – FUSE, 5 AMP
- F2 – FUSE, 5 AMP
- F3 – FUSE, 5 AMP
- G1 – GAUGE, OIL PRESSURE
- G2 – GAUGE, OIL PRESSURE
- H1 – HOURMETER
- H2 – FREQUENCY METER
- L1 – LAMP, FAULT
- L2 – LAMP, PANEL
- L3 – LAMP, RUN RELAY
- PHR – POTENTIOMETER
- PT – POTENTIOMETER
- R1 – RESISTOR, ENGINE ALTERNATOR
- R2 – RESISTOR, ENGINE ALTERNATOR
- R3 – RESISTOR, FIELD BOOST
- R4 – RESISTOR, FIELD BOOST
- SW1 – SWITCH, START/RUN/STOP
- SW2 – SWITCH, PREHEAT
- SW3 – SWITCH, PHASE SELECTOR
- SW4 – SWITCH, PHASE SELECTOR
- SW5 – SWITCH, AUTO/OFF/MANUAL
- SW6 – SWITCH, AUTO/OFF/MANUAL
- VM – VOLTAGE METER, AC
- VR – VOLTAGE REGULATOR

CONTACTS	POSITION	1	2	3	OFF
2 – 3		0	X	X	X
2 – 7		X	0	X	X
2 – 11		X	0	X	0
12 – 3		X	0	X	0
12 – 7		0	X	0	0
12 – 11		0	X	0	0
15 – 14		X	0	0	0
15 – 18		X	0	X	0
15 – 16		X	0	X	0
19 – 14		0	X	0	X
19 – 14		0	0	X	0
X INDICATES CLOSED					

Electrical Data

GR-25 Generator Set

Wiring Diagram – AC Receptacle Panel – Drawing No. 0A8071-D

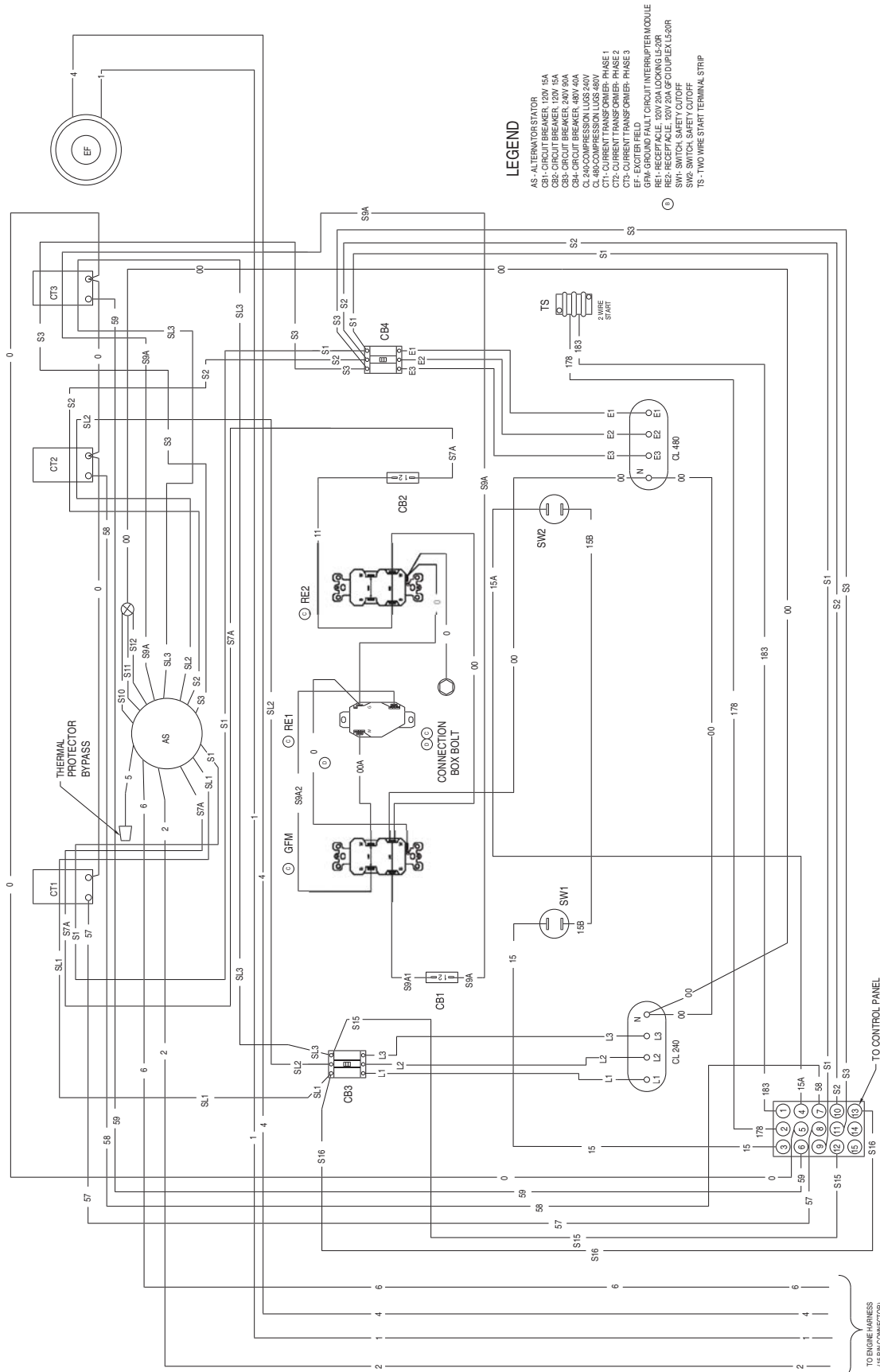
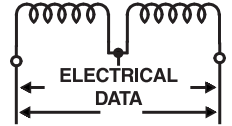

LEGEND

- AS- ALTERNATOR STATOR
- CB1- CIRCUIT BREAKER, 120V, 15A
- CB2- CIRCUIT BREAKER, 120V, 15A
- CB3- CIRCUIT BREAKER, 240V, 50A
- CB4- CIRCUIT BREAKER, 480V, 40A
- CB5- CIRCUIT BREAKER, 480V, 40A
- CL480- COMPRESSOR LOSS, 480V
- CT1- CURRENT TRANSFORMER, PHASE 1
- CT2- CURRENT TRANSFORMER, PHASE 2
- CT3- CURRENT TRANSFORMER, PHASE 3
- EF- ENGINE FAULT
- GFI- GROUND FAULT CIRCUIT INTERRUPTER MODULE
- RE1- RECEPTACLE, 120V, 20A, LOCKING, L5-20R
- RE2- RECEPTACLE, 120V, 20A, GFCI, DUPLEX, L5-20R
- SW1- SWITCH, SAFETY CUTOFF
- SW2- SWITCH, SAFETY CUTOFF
- TS- 110V WIRE START TERMINAL STRIP

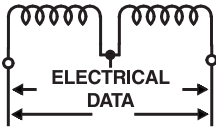

Electrical Data

GR-25 Generator Set

Schematic – AC Receptacle Panel – Drawing No. 0A8072-B

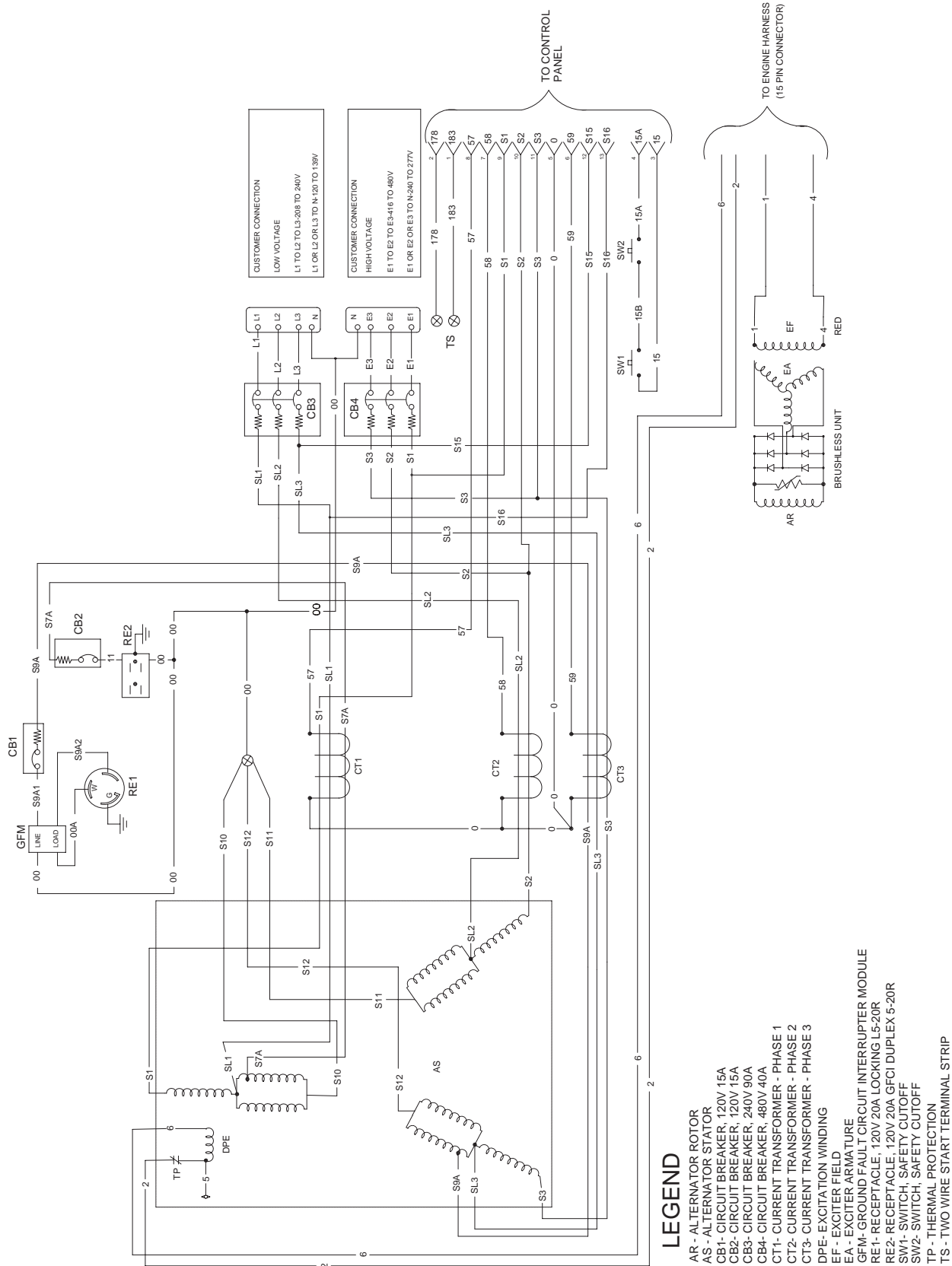

LEGEND

- AR - ALTERNATOR ROTOR
- AS - ALTERNATOR STATOR
- CB1 - CIRCUIT BREAKER, 120V 15A
- CB2 - CIRCUIT BREAKER, 120V 15A
- CB3 - CIRCUIT BREAKER, 240V 90A
- CB4 - CIRCUIT BREAKER, 480V 40A
- CT1 - CURRENT TRANSFORMER - PHASE 1
- CT2 - CURRENT TRANSFORMER - PHASE 2
- CT3 - CURRENT TRANSFORMER - PHASE 3
- DPE - EXCITATION WINDING
- EF - EXCITER FIELD
- EA - EXCITER ARMATURE
- GFM - GROUND FAULT CIRCUIT INTERRUPTER MODULE
- RE1 - RECEPTACLE, 120V 20A LOCKING L5-20R
- RE2 - RECEPTACLE, 120V 20A GFCI DUPLEX 5-20R
- SW1 - SWITCH, SAFETY CUTOFF
- SW2 - SWITCH, SAFETY CUTOFF
- TP - THERMAL PROTECTION
- TS - TWO WIRE START TERMINAL STRIP

(B)

Electrical Data
GR-25 Generator Set

Wiring Diagram – Diesel Engine – Drawing No. 0A8665-A

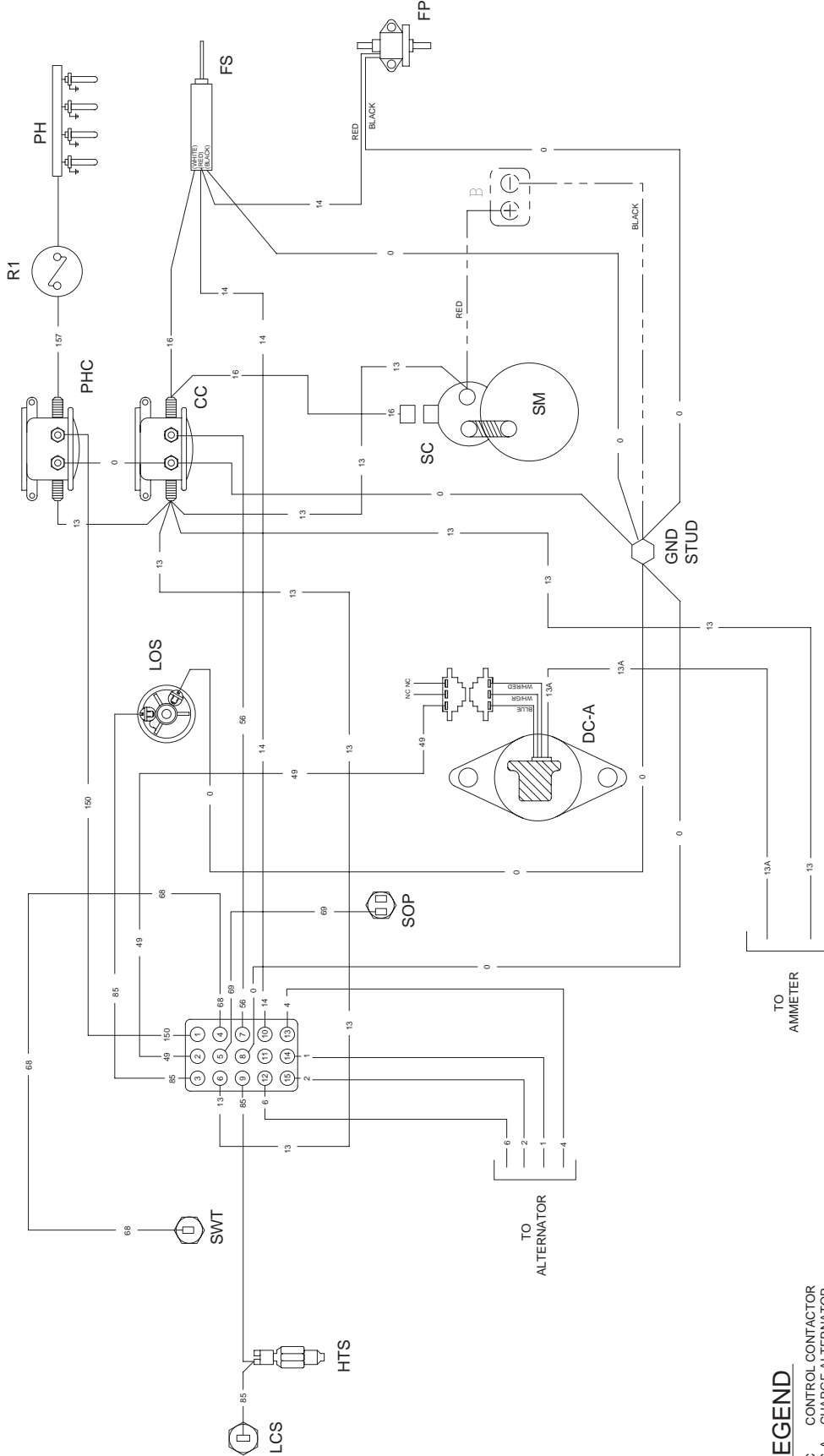
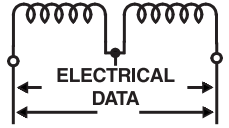

LEGEND

- CC CONTROL CONTACTOR
- DC-A CHARGE ALTERNATOR
- FP FUEL PUMP
- FS FUEL SOLENOID
- LOS LOW OIL SWITCH
- PH PREHEAT/GLOW-PLUGS
- PHC PRE-HEAT CONTACTOR
- R1 PRE-HEAT RESISTOR
- SC STARTER CONTACTOR
- SM STARTER MOTOR
- SOP OIL PRESS SENSOR
- SWT WATER TEMP SENSOR
- WLS WATER LEVEL SENSOR
- WTS WATER TEMP SWITCH

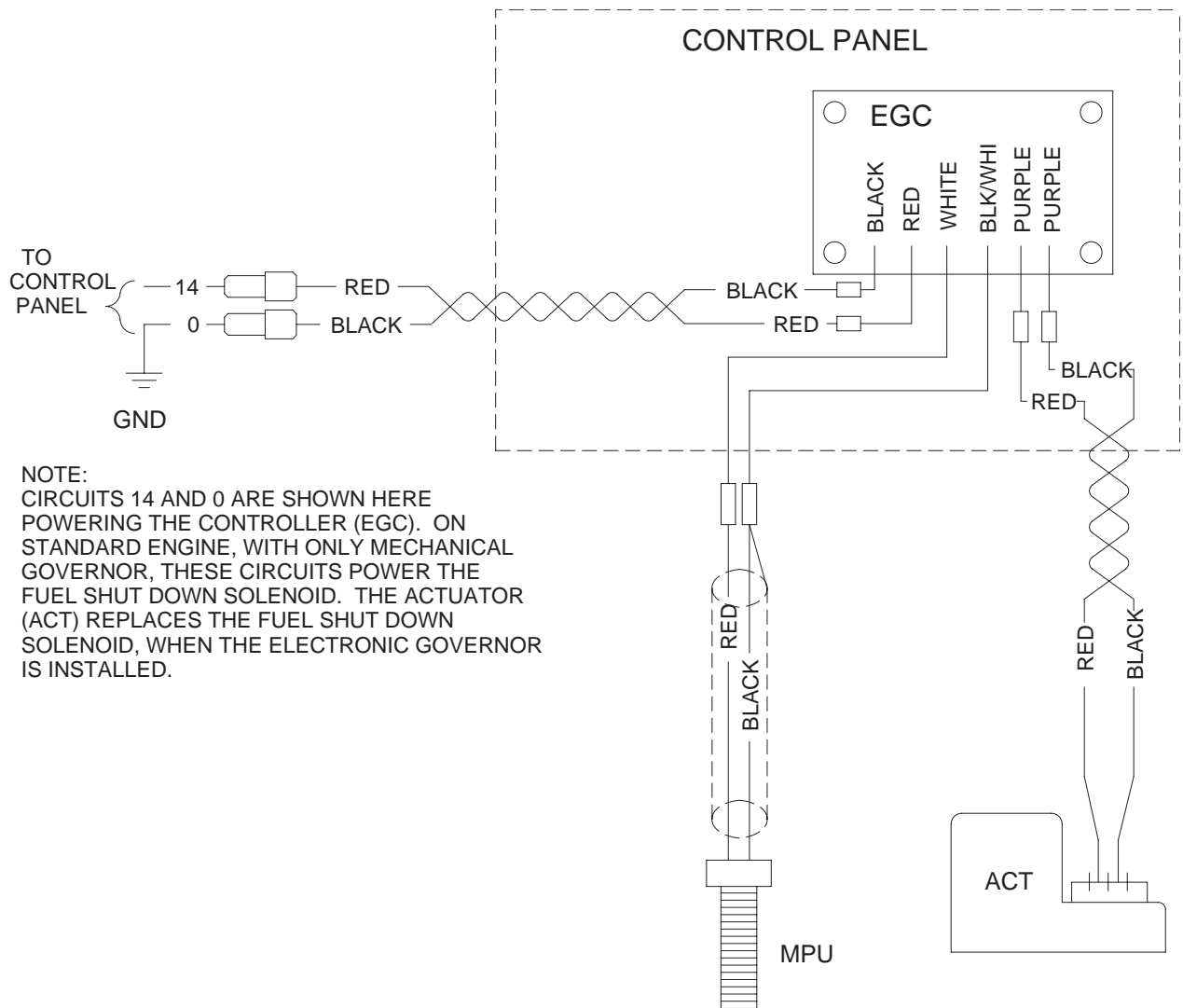
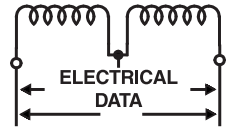

NOTE:
CIRCUITS 14 AND 0 ARE SHOWN HERE
POWERING THE CONTROLLER (EGC). ON
STANDARD ENGINE, WITH ONLY MECHANICAL
GOVERNOR, THESE CIRCUITS POWER THE
FUEL SHUT DOWN SOLENOID. THE ACTUATOR
(ACT) REPLACES THE FUEL SHUT DOWN
SOLENOID, WHEN THE ELECTRONIC GOVERNOR
IS INSTALLED.

LEGEND

- ACT - ACTUATOR
- EGC - ELECTRONIC GOVERNOR CONTROLLER
- MPU - MAGNETIC PICK-UP

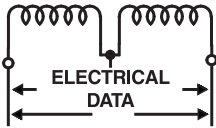

Electrical Data

GR-25 Generator Set

Schematic – 12V 2A Connection – Drawing No. 0D4688

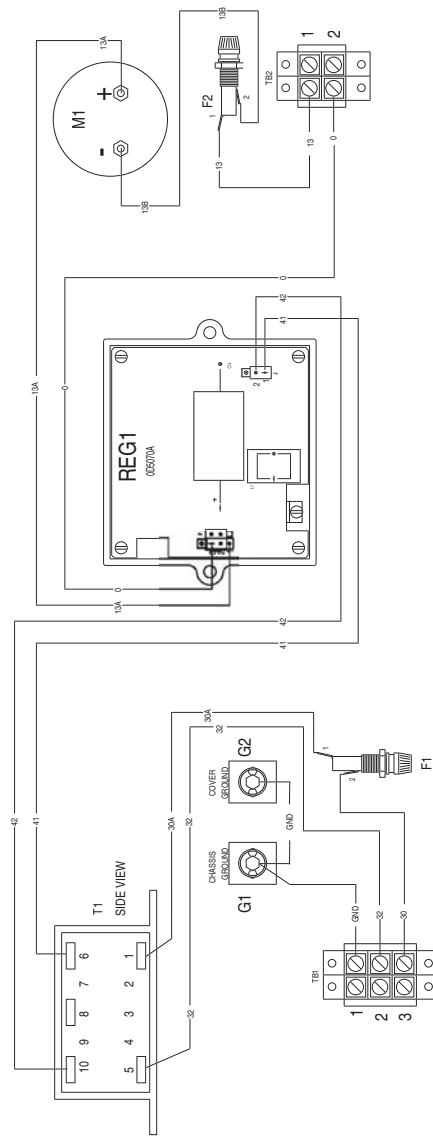
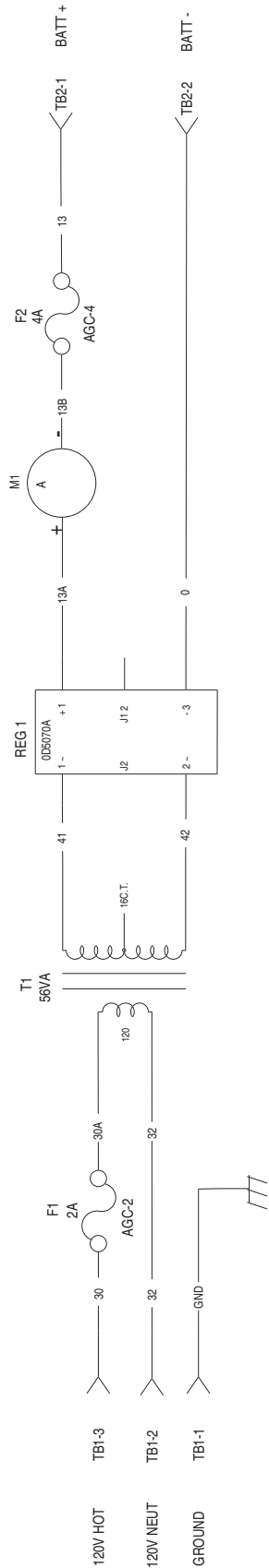

Exploded View and Parts List

GR-25 Generator Set

Block Heater – Drawing No. 0A9668-B

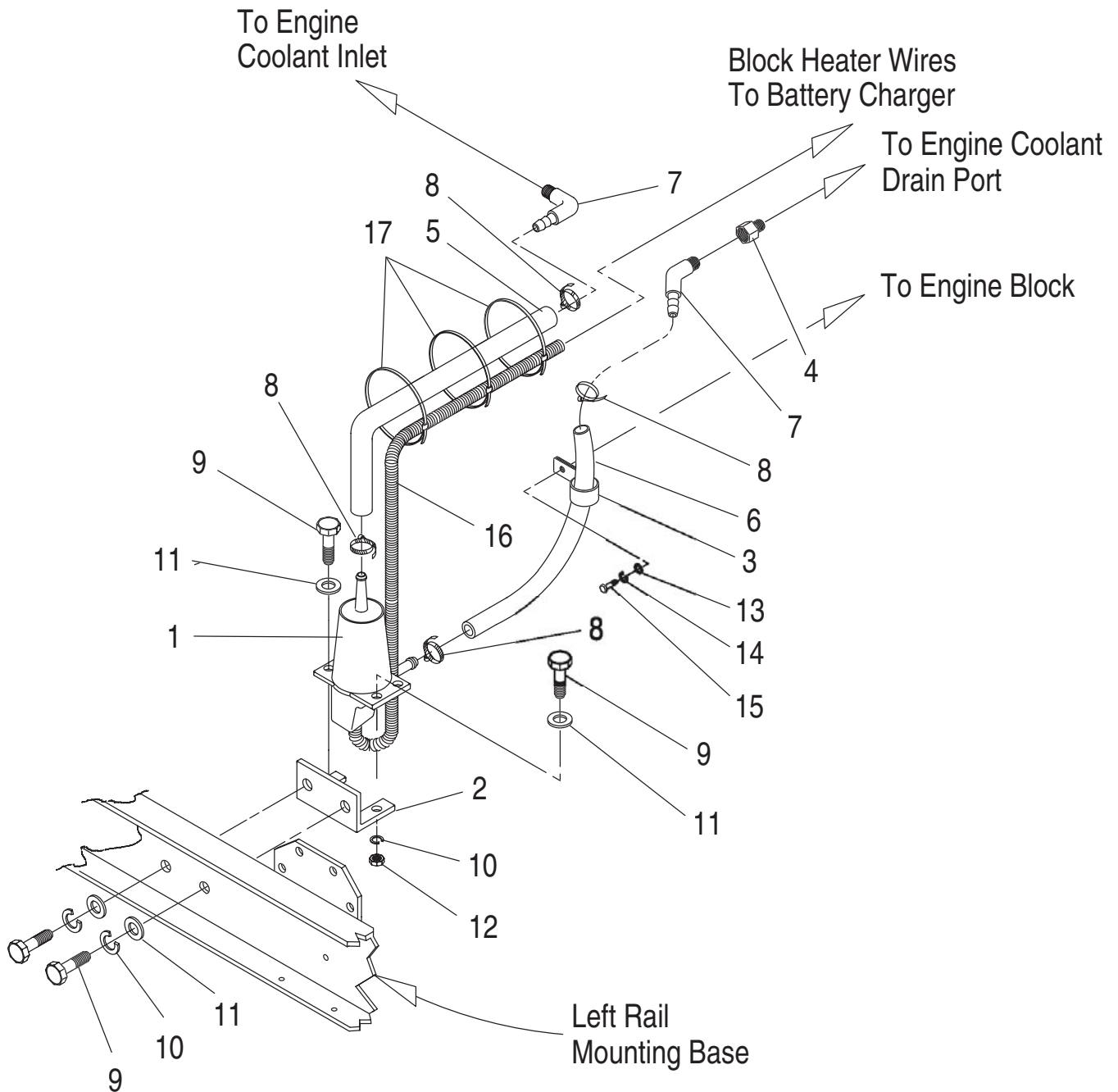
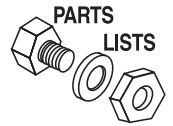

ITEM	PART NO.	QTY.	DESCRIPTION	ITEM	PART NO.	QTY.	DESCRIPTION
1	084918A	1	HEATER,ENG 1000W120V	10	022097	4	WASHER LOCK M6-1/4
2	084427	1	BRACKET, HEATER	11	022473	4	WASHER FLAT 1/4 ZINC
3	055934	1	HOSE CLAMP	12	049813	2	NUT HEX M6-1.0 G8 YEL CHR
4	062303	1	ADAPTOR 1/4" NPT TO 3/8" NPT	13	022131	1	WASHER FLAT 3/8-M10 ZINC
5	050967	23"	HOSE 5/8 ID RIA 250F	14	046526	1	WASHER LOCK M10
6	050967	20"	HOSE 5/8 ID RIA 250F	15	051756	1	SCREW HHC M10-1.5 X 20 G8.8
7	034339	2	BARBED EL 90 3/8NPT X 5/8	16	077043A	30"	CONDUIT FLEX .38 ID
8	057823	4	CLAMP HOSE #10 .56 - 1.06	17	028739A	3	TIE WRAP 3.9" X .10" BLK UL
9	047411	4	SCREW HHC M6-1.0 X 16 G8.8				

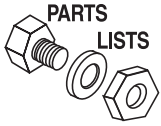

Exploded View and Parts List

GR-25 Generator Set

Control Panel – Drawing No. 0A9705-D

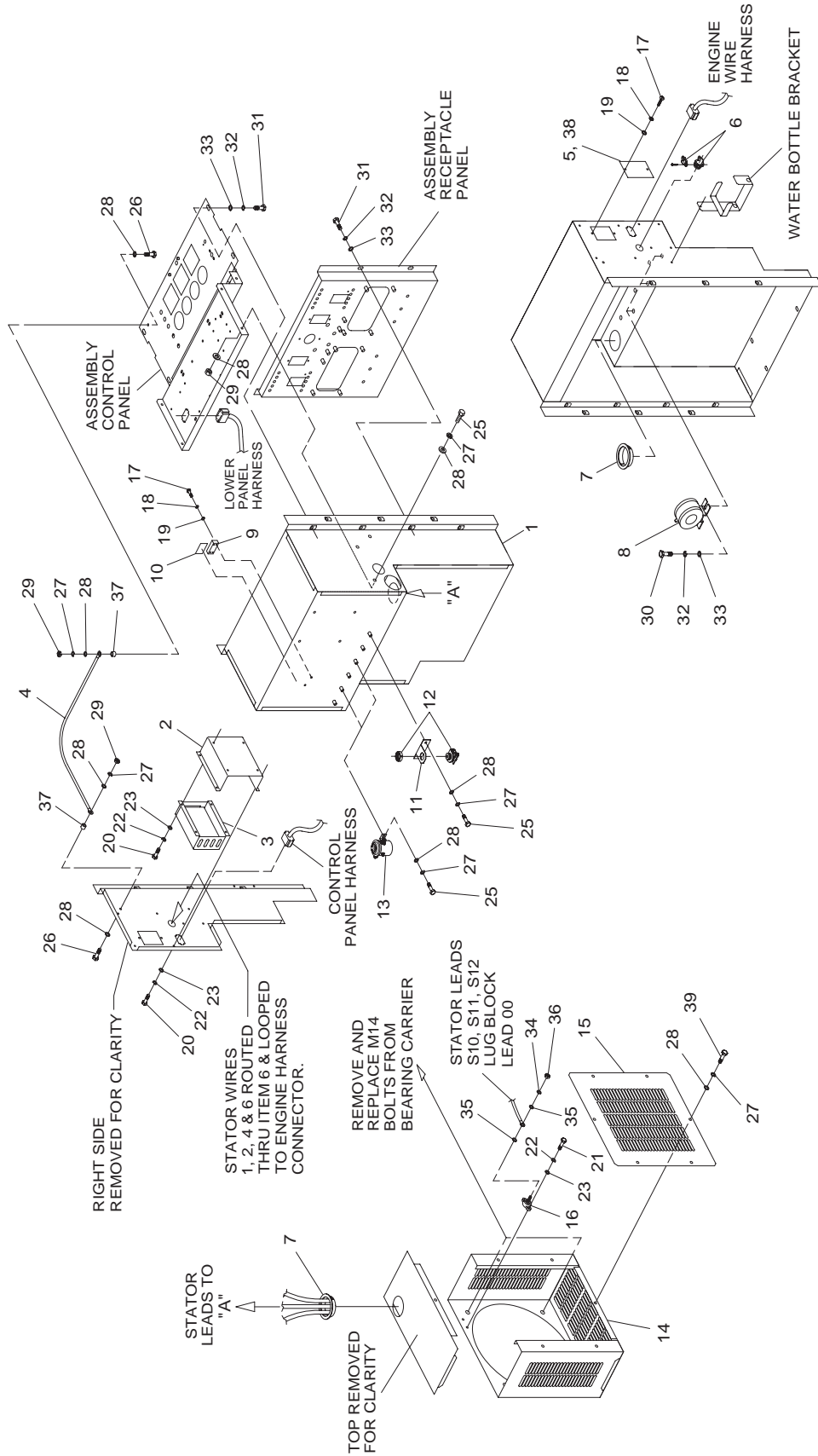

Exploded View and Parts List

GR-25 Generator Set

Control Panel – Drawing No. 0A9705-D

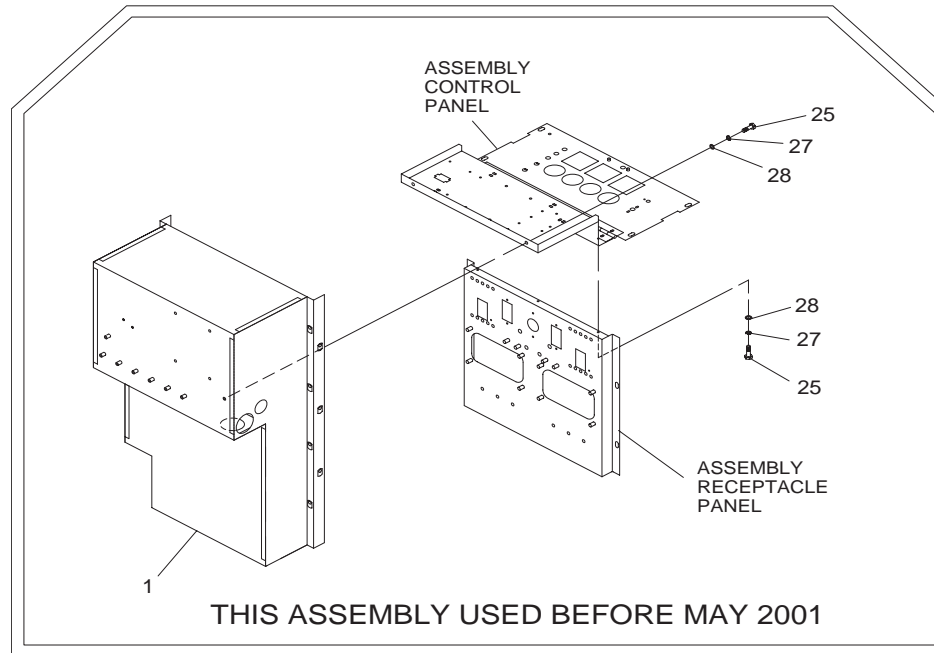
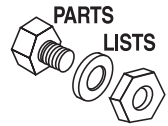

ITEM	PART NO.	QTY.	DESCRIPTION	ITEM	PART NO.	QTY.	DESCRIPTION
1	0A9030	1	WLDMNT CNT BOX 2.2L	20	024413	8	SCREW HHTT #10-32 X 1/2 BP
2	0A9473	1	CHASSIS AVR 2.2LGR25	21	033138	2	SCREW HHM #10-32 X 5/8
3	067680	1	ASSY VOLTAGE REGULATOR 60HZ	22	022152	10	WASHER LOCK #10
4	090515	1	CABLE-CONTROL PANEL	23	023897	10	WASHER FLAT #10 ZINC
5	0A1441A	1	COVER PLATE, E-GOV	25	047411	12	SCREW HHC M6-1.0 X 16 G8.8
6	034616	1	FITTING STRAIGHT 3/4	26	045757	2	SCREW HHC M6-1.0 X 25 G8.8
7	023484N	1	BUSHING SNAP SB-2.5-31	27	022473	22	WASHER FLAT 1/4 ZINC
8	061395	3	TRANSFRM 100V TO 5A	28	022097	22	WASHER LOCK M6-1/4
9	048766	1	BLOCK TERM 20A 2 X 6 X 1100V	29	049813	8	NUT HEX M6-1.0 G8 YEL CHR
10	064828	1	DECAL TRAN SW CONN	30	036223	6	SCREW HHC 5/16-18 X 1/2
11	0A9397	1	BRACKET, RESISTER, 2.2L	31	0A6928	8	SCREW HHC M8-1.25 X 20 SS G8.8
12	0A9858	1	RESISTOR, 2.2L GPLUG	32	022129	14	WASHER LOCK M8-5/16
13	056739	2	RELAY SOLENOID 12VDC PNL MNT	33	022145	14	WASHER FLAT 5/16 ZINC
14	0A9108	1	WLDMT LWRCON BOX 2.2	34	046526	1	WASHER LOCK M10
15	0A9109	1	COVER CON BOX 2.2L	35	022131	2	WASHER FLAT 3/8-M10 ZINC
16	057073	1	JUNCTION BLOCK 3/8-16	36	022241	1	NUT HEX 3/8-16 STEEL
17	036901	4	SCREW PPHM #6-32 X 3/8	37	038196	2	SPACER .28 X .62 X .19 STL/ZNC
18	022155	4	WASHER LOCK #6	38	0C1127	1	DECAL AVR COVER
19	022985	4	WASHER FLAT #6 ZINC	39	022287	6	SCREW HHC 1/4-20 X 3/4 G5

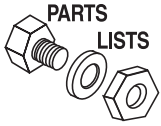

Exploded View and Parts List

GR-25 Generator Set

Trailer – Drawing No. 0A8389-B

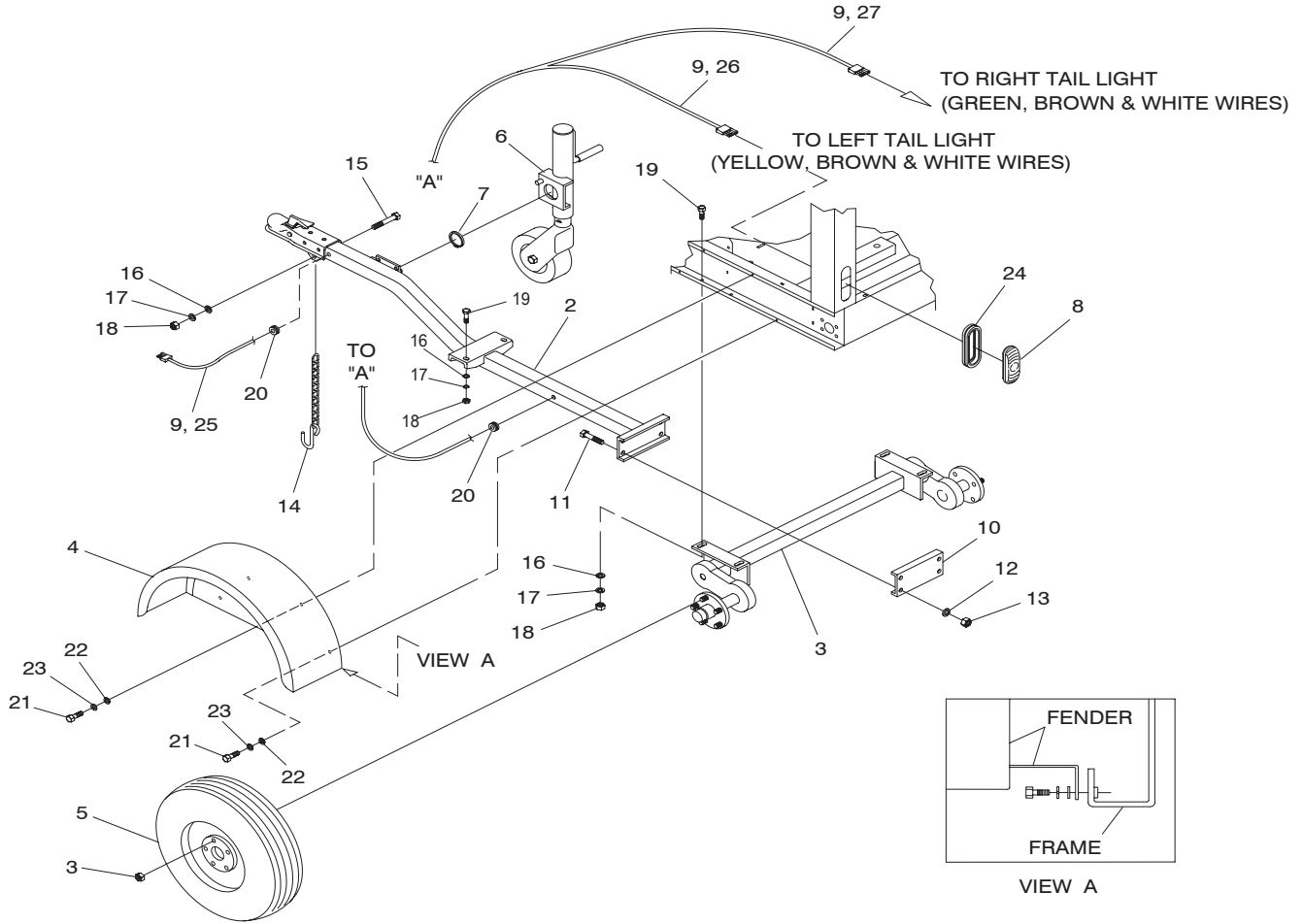

TORQUE SPECIFICATIONS:
 ITEM 3 STAGE 1 20-25 FT. LBS
 STAGE 2 50-60 FT. LBS
 STAGE 3 90-120 FT. LBS
 ITEM 11-----90 FT. LBS
 ITEM 15 & 19 TIGHTEN ALL TO 60 FT. LBS

ITEM	PART NO.	QTY.	DESCRIPTION	ITEM	PART NO.	QTY.	DESCRIPTION
2	0A8284	1	WLDMNT, TOWBAR GR-25	15	0C2071	1	SCREW HHC 1/2-13 X 3-1/2 G8
3	0A8283	1	AXLE T-FLEX #10 3500	16	022304	7	WASHER FLAT 1/2 ZINC
4	0A8285	2	ASSY FENDER 25K TRAIL	17	022195	7	WASHER LOCK 1/2
5	0A8286	2	ASSY WHEEL 215-75-R14	18	022196	7	NUT HEX 1/2-13 STEEL
6	0A3910A	1	JOCKEY WHEEL	19	0C2074	6	SCREW HHC 1/2-13 X 1-1/2 G8
7	081779	1	SNAP RING EXT 2.500 X 2.313	20	029107	2	GROMMET 7/8 X 3/16 X 5/8
8	0A9077	2	LITE TAIL OVAL	21	042907	8	SCREW HHC M8-1.25 X 16 G8.8
9	0A9078	1	HARNES TRLR GR25	22	022129	8	WASHER LOCK M8-5/16
10	0A8319	1	BRACKET, AXLE 3SQ 25K	23	022145	2	WASHER FLAT 5/16 ZINC
11	0A8388	4	SCREW HHC 9/16-12 X 4 G5	24	0A9821	2	GROMMET TAILLITEGR25
12	043123	4	WASHER LOCK M14	25	077043A	19"	CONDUIT FLEX .38 ID
13	0A6054	4	NUT, 9/16-12	26	077043A	68"	CONDUIT FLEX .38 ID
14	0A3963	1	CHAIN SAFETY 1L TRAILER	27	077043A	68"	CONDUIT FLEX .38 ID

Exploded View and Parts List
GR-25 Generator Set
Center Lift – Drawing No. 0A9564-C

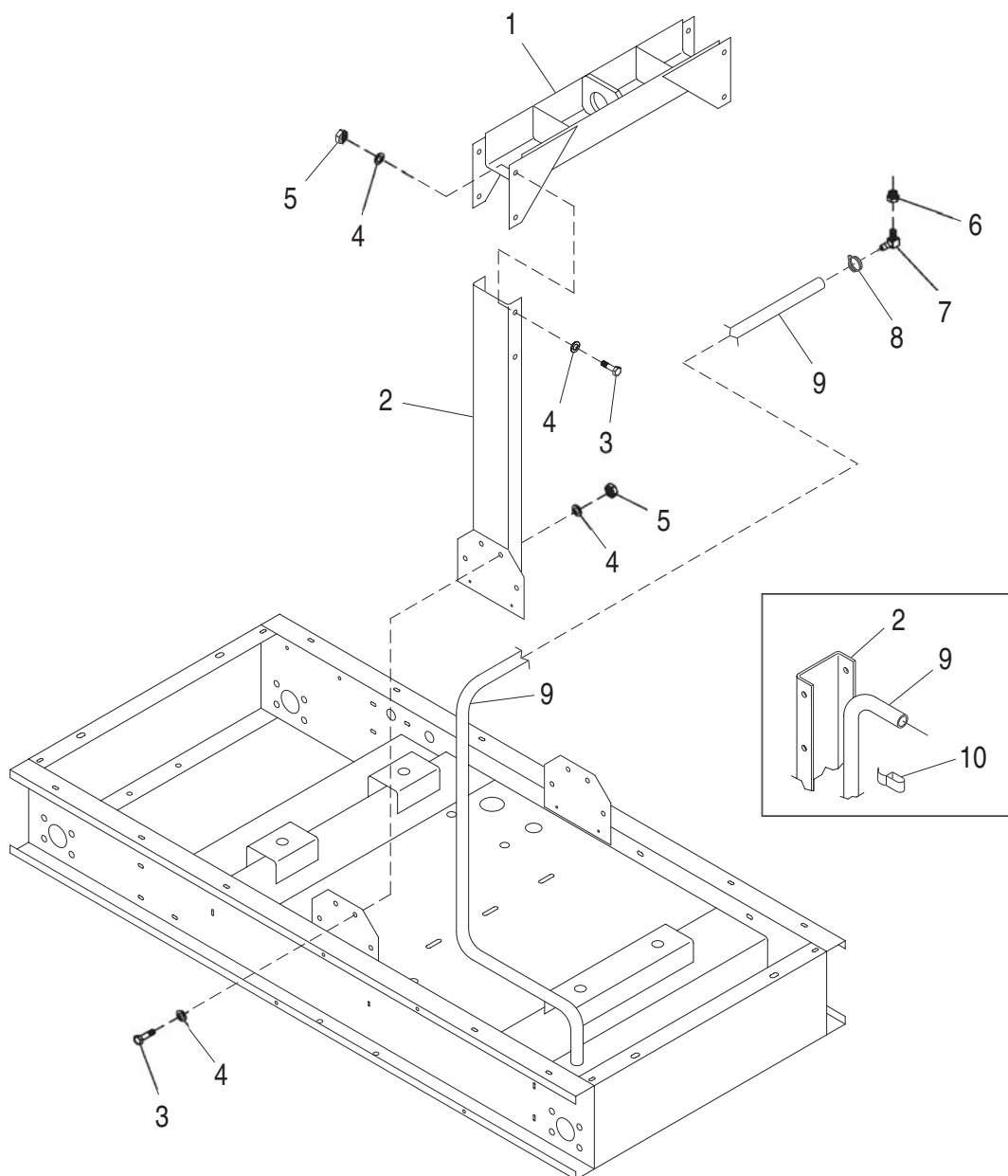
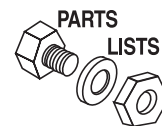

ITEM	PART NO.	QTY.	DESCRIPTION
1	0A8995	1	ASSY CENTER LIFT TOP
2	0A9000	2	ASSY CENTER LIFT POST
3	059921	16	SCREW HHC M12-1.75 X 40 G10.9
4	022250	32	WASHER FLAT 7/16
5	052860	16	NUT TOP LOCK FL M12-1.75
6	046747	1	BUSHING REDUCER 3/4 TO 3/8
7	043790	1	BARBED EL 90 3/8 NPT X 3/8
8	040173	1	CLAMP HOSE #5.5 .62-.62
9	047290	85"	HOSE 3/8 ID SINGLE BRAID
10	079994	2	FRAME CLIP #FC-3032



Exploded View and Parts List

GR-25 Generator Set

Mounting Base – Drawing No. 0A9563-K

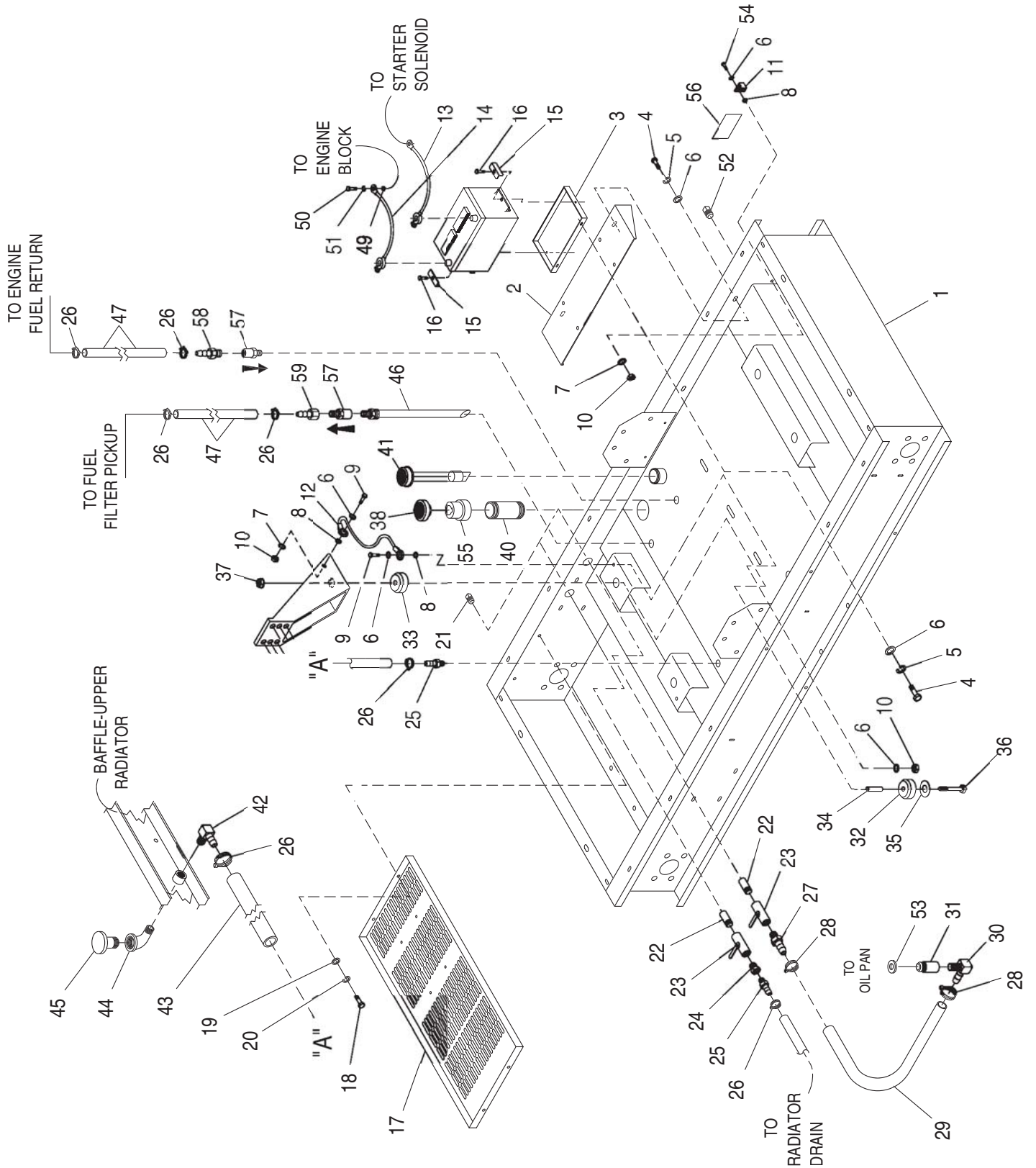

Exploded View and Parts List

GR-25 Generator Set

Mounting Base – Drawing No. 0A9563-K

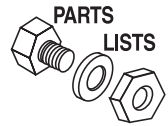

ITEM	PART NO.	QTY.	DESCRIPTION	ITEM	PART NO.	QTY.	DESCRIPTION
1	0A8321	1	BASE MOUNTING 2.2L W/ 44 GAL. TNK	31	0A8583	1	ADAPTOR M20 X 3/8 NPT
2	0A8334	1	SUPPORT CNTRL PNL2.2	32	052251	4	DAMPENER VIB 40 BLUE
3	0A8333	1	TRAY BATTERY 2.2L ISU	33	052252	4	DAMPENER VIBRATION
4	051756	4	SCREW HHC M10-1.5 X 20 G8.8	34	052257	4	SPACER .49 X .62 X 1.87 PWDR/ZINC
5	046526	4	WASHER LOCK M10	35	052259	4	WASHER FLAT M12
6	022131	7	WASHER FLAT 3/8-M10 ZINC	36	055597	4	SCREW HHC M12-1.75 X 85 G8.8
7	0A4456	3	3/8 SPECIAL L/WASHER	37	052860	4	NUT LOCKING M12-1.75
8	025507	3	WASHER SHAKEPROOF EXT 7/16 STL	38	091057	1	CAP-FUEL FILL
9	029745	2	SCREW HHC 3/8-16 X 1 G5	40	090608	1	NIPPLE PIPE 2 NPT X 7 BLK IRON
10	022241	3	NUT HEX 3/8-16 STEEL	41	021973D	1	GAUGE FUEL LEVEL 187
11	061383	1	LUG SLDLSS 3/0-#4 X 13/32 CU	42	043790	1	ELBOW BARBED 90 3/8 NPT X 3/8
12	0536210098	1	GNDWIRE ASSY 10"/3/8	43	047290	1	HOSE 3/8 ID SINGLE BRAID
13	038804Y	1	CABLE BATT RED #1 X 35.00	44	026924	1	ELBOW 90D STREET 3/8
14	038805X	1	CABLE BATT BLK #1 X 17.00	45	026847	1	BREATHER
15	059473	2	HOLD DOWN BATTERY	46	021623J	1	FUEL DIP PIPE 178MM
16	039287	2	SCREW HHC M8-1.25 X 45 G8.8	47	074995	1	HOSE 1/4 ID PETROLEUM (36"LG)
17	0A8565	REF	SUPPORT,MUFFLER 2.2L	49	070022	1	WASHER STAR M12 EXT
18	0A6928	REF	SCREW HHC M8-1.25 X 20 SS G8.8	50	052617	1	SCREW HHC M12-1.75 X 20 G8.8
19	022129	REF	WASHER LOCK M8-5/16	51	051769	1	WASHER LOCK M12
20	022145	REF	WASHER FLAT 5/16 ZINC	52	025655	1	PLUG STD PIPE 3/4 STEEL SQ HD
21	024310	2	PLUG STD PIPE 1/2 STEEL SQ HD	53	0D4849	1	WASHER FLAT M20 COPPER 1.5 THK
22	088195	2	NIPPLE CLOSE 1/2 NPTX1.125 BRSS	54	049541	1	SCREW HHC M10-1.5 X 35 G8.8
23	078944	2	VALVE BALL	55	091058	1	NECK-FUEL FILL
24	030418	1	BUSHING REDUCER 1/2 TO 3/8	56	094988	1	DECAL-GROUNDING
25	055596	2	BARBED STR 3/8 NPT X 3/8	57*	070327	1	VALVE,CHECK 3/8" NPT
26	035472	7	CLAMP HOSE #6 .43 - .78	58	0D5614	1	BARBED STR MA 3/8" NPT X 1/4"
27	044118	1	BARBED STR 1/2 NPT X 5/8	59	0D3038B	1	BARBED STR FE 3/8 NPT X 1/4"
28	057823	2	CLAMP HOSE #10 .56 - 1.06				
29	057448	1	HOSE 5/8 ID TYPE 3 SINGLE				
30	034339	1	BARBED EL 90 3/8 NPT X 5/8				

*ENSURE ARROW POINTS IN DIRECTION OF FUEL FLOW.



Exploded View and Parts List

GR-25 Generator Set

Compartment – Drawing No. 0D4174-C

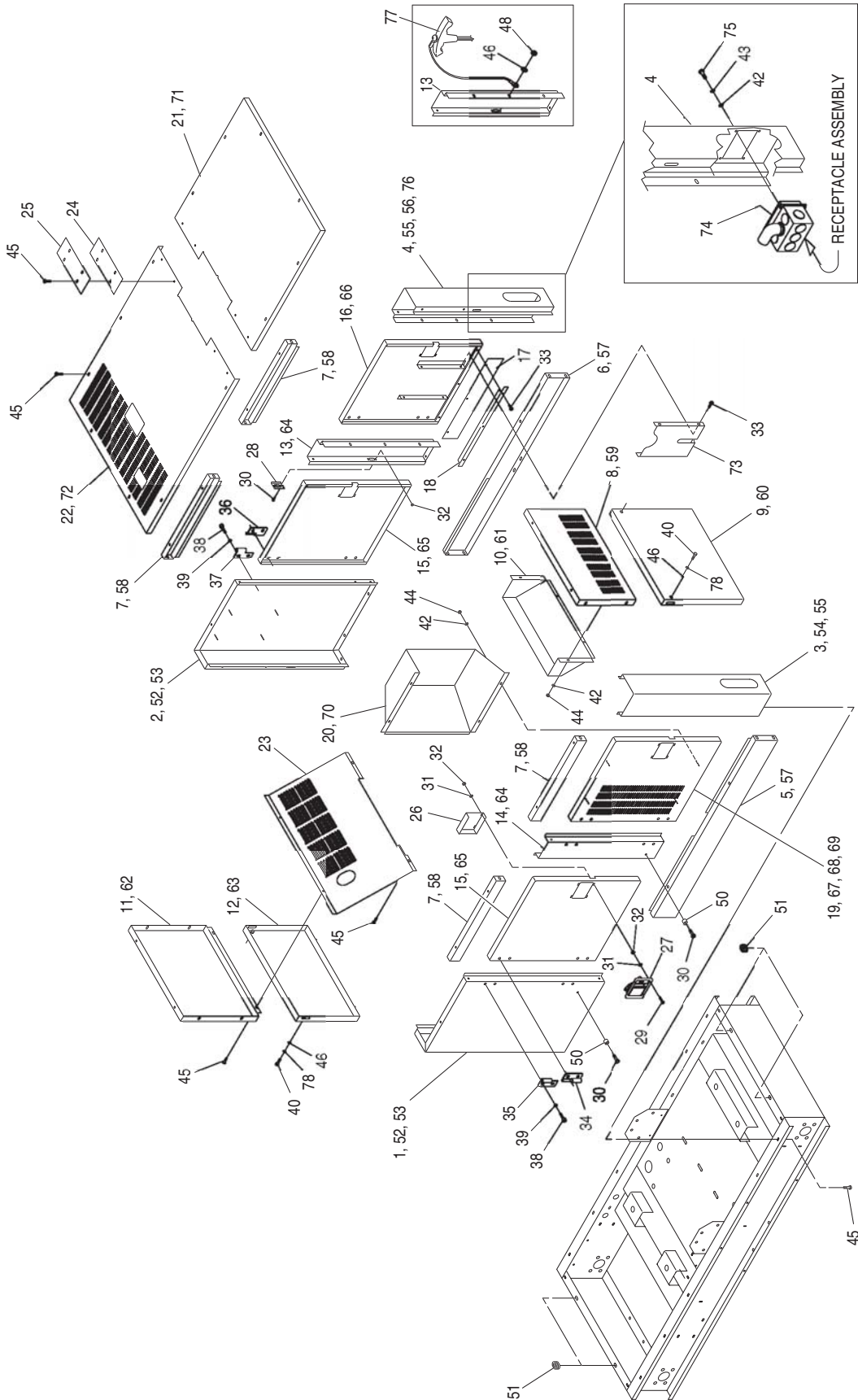

Exploded View and Parts List

GR-25 Generator Set

Compartment – Drawing No. 0D4174-C

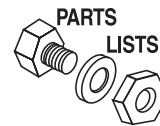

ITEM	PART NO.	QTY.	DESCRIPTION	ITEM	PART NO.	QTY.	DESCRIPTION
1	0D4168	1	CORNER POST L. FRT GR-25 D/1	39	0A5992	32	WASHER SHAKEPROOF INT M8 SS
2	0D4169	1	CORNER POST R. FNT GR-25 D/1	40	0D4202	4	SCREW HHC M8-1.0 X 55 SSTL
3	0D4170	1	CORNER POST L. REAR GR-25 D/1	42	070007	14	WASHER FLAT M6 SS
4	0D4171	1	CORNER POST R. REAR GR-25 D/1	43	084156	4	WASHER LOCK M6 SSTL
5	0A8808	1	BRACE SIDE BOTTOM LH	44	077992	10	NUT LOCK FL M6-1.0 SSTL
6	0A8809	1	BRACE SIDE BOTTOM RH	45	0C1754	68	SCREW TAP M8 W/WASHR
7	0A8591	4	BRACE RH SIDE TOP	46	070008	20	WASHER FLAT M8 SS
8	0A8578	1	BRACE REAR TOP 2.2L	48	070004	3	NUT HEX M8-1.25 G8 SSTL
9	0D4173	1	PANEL REAR GR-25 D/1	50	091006	4	BUMPER RUBBER
10	0A8579	1	DUCT REAR PANEL 2.2	51	029107	4	GROMMET 7/8 X 3/16 X 5/8
11	0A8811	1	BRACE FRONT TOP 2.2L	52	0A9126000A	2	CPOST FRONT #1
12	0D4172	1	PANEL FRONT GR-25 D/1	53	0A9126000B	2	CPOST FRONT #2
13	0A8572	1	SPPRT SIDE COMP. RH	54	0A9126000C	1	CPOST REAR #1 LH
14	0A8573	1	SPPRT SIDE COMP. LH	55	0A9126000D	2	CPOST REAR #2
15	0A8807	2	DOOR FRONT 2.2L ISU	56	0A9126000E	1	CPOSTREAR #1 R/H UPPER
16	0A8582	1	DOOR RH SIDE 2.2L	57	0A9126000F	2	BRACE SIDE LOWER
17	0A9084	1	SPLASH GAURD 2.2L	58	0A9126000G	4	BRACE SIDE TOP
18	0A9085	1	BRACKET 4 SPLASH GRD	59	0A9126000H	1	PANEL UPPER REAR
19	0A8580	1	DOOR SLOTTED LH 2.2	60	0A9126000I	1	PANEL LOWER REAR
20	0A8581	1	DUCT SIDE DOOR	61	0A9126000J	1	DUCT REAR
21	0A8575	1	ROOF REAR	62	0A9126000K	1	PANEL UPPER FRONT
22	0A8576	1	ROOF FRONT	63	0A9126000L	1	PANEL LOWER FRONT
23	0A8812	1	BAFFLE FRONT 2.2L	64	0A9126000M	1	SIDE SUPPORT
24	0A9107	1	SEAL ROOF 2.2L ISUZ	65	0A9126000N	2	DOOR SIDE (FRONT)
25	0A9023	1	SEAL,ROOF CHANNEL 2.2	66	0A9126000O	1	DOOR SIDE (REAR RH)
26	083078	4	COVER DOOR LATCH	67	0A9126000P	1	DOOR SIDE (REAR LH)
27	060069	4	PADDLE HANDLE LOCK	68	0A9126000Q	2	DOOR REAR (LHTOP)
28	080476	4	PLATE STRIKER	69	0A9126000R	1	DOOR REAR (LHSIDE)
29	0D6404	16	SCREW PPHM #8-32 X 1 5/8" SS	70	0A9126000S	1	DUCT DOOR REAR LH
30	089905	8	SCREW PFHM #8-32 X 3/4 SS	71	0A9126000T	1	ROOF REAR
31	080490	17	WASHER FLAT #8 SS	72	0A9126000U	1	ROOF FRONT
32	063480	25	NUT LOCK HEX #8-32 NYL INS ZNC	73	0A9945	1	HOLDER MANUAL GR-25
33	0A7215	7	SCREW SW 1/4-20 X 5/8 N WA JS500	74	091081	.5 oz	RTV-WHITE
34	0A4122A	4	HINGE SLIP MALE RH	75	070001	4	SCREW HHC M6-1.0 X 20 SS G8.8
35	0A4122B	4	HINGE SLIP FEMALE RH	76	0A9126000V	1	C POST REAR #1 R/H LOWER
36	0A4122C	4	HINGE SLIP MALE LH	77	091175	1	ASSEMBLY WRENCH HEX 3/8
37	0A4122D	4	HINGE SLIP FEMALE LH	78	022097	4	WASHER LOCK M6-1/4
38	0A5991	32	SCREW BHSC M8-1.25 X 16 SS				

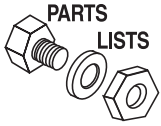

Exploded View and Parts List

GR-25 Generator Set

Battery Charger – Drawing No. 0A9702-F

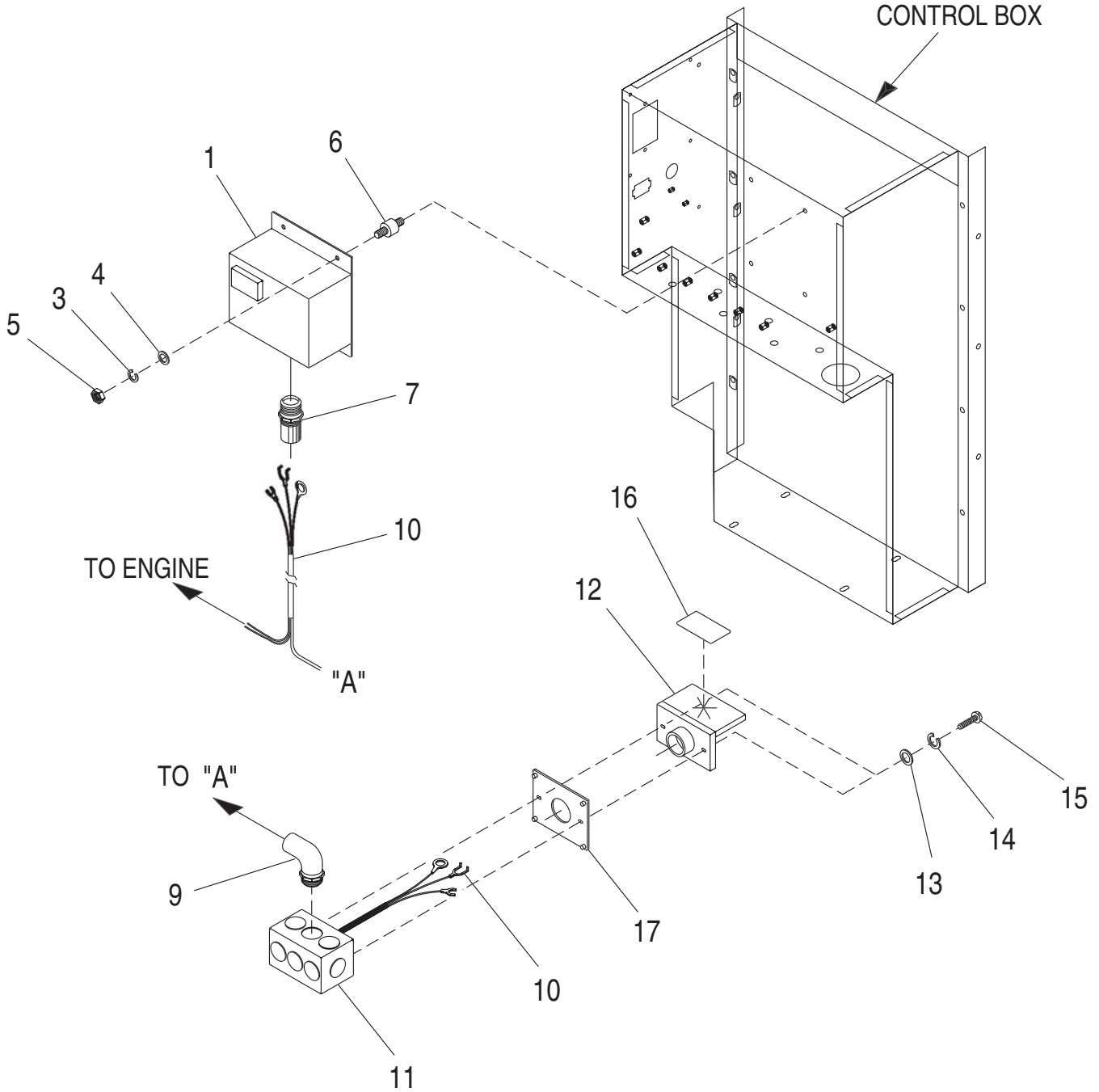

ITEM	PART NO.	QTY.	DESCRIPTION	ITEM	PART NO.	QTY.	DESCRIPTION
1	0D3490	1	ASSY,BATTERY CHAGER 12V 10AMP	10	0C2292	1	HARNES BATTERY CHARGER
	0D4687	1	BATTERY CHARGER ASSY,12V,2A,UL	11	062141	1	OUTLET BOX #670
3	022097	4	WASHER LOCK M6-1/4	12	0A9941	1	PLUG RECESSED WEATHERPROOF 20A
4	022473	4	WASHER FLAT M6-1/4 ZINC	13	081799	2	WASHER FLAT #6 SS
5	022127	4	NUT HEX 1/4-20 STEEL	14	081797	2	WASHER LOCK 6 SS
6	027831	4	MOUNT VIBR .50X1.0X.50	15	091198	2	SCREW PPHM #6-32 X 5/8 SS
7	022206	1	CONNECTOR STRAIGHT	16	091233	1	DECAL UTILITY CONNECT
9	060015	1	FITTING 90 DEGREE 3/8	17	0C1555	1	RECEP. MNT. PLATE

Exploded View and Parts List

GR-25 Generator Set

Receptacle Panel – Drawing No. 0A9704-E

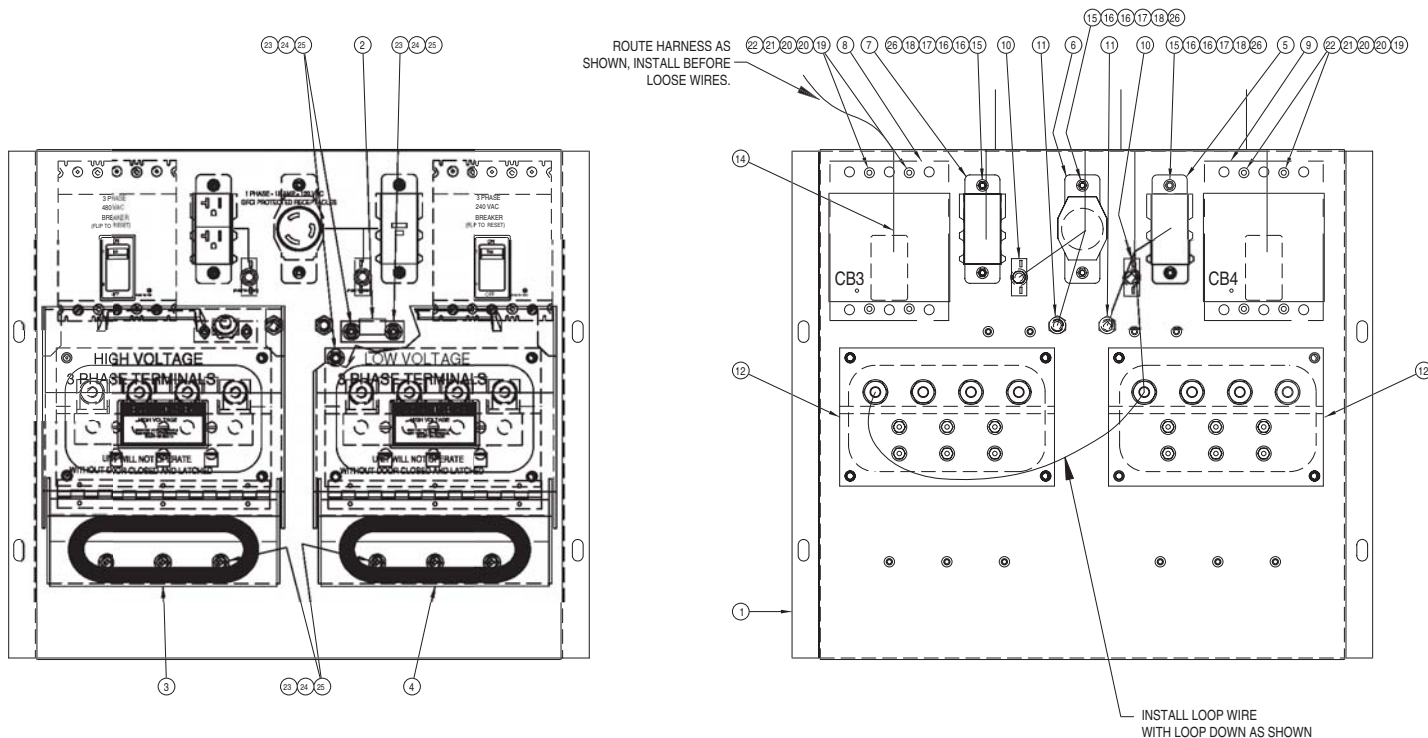
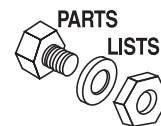

ITEM	PART NO.	QTY.	DESCRIPTION
1	0A8852	1	PANELRCPT W/SLKSCRN
2	0A8847	2	HASP LUG BOX 2.2L
3	0A8850	1	ASSY LUG BOX HI VT
4	0A8851	1	ASSY LUG BOX LO VT
5	080409	1	RECEP DUPLEX GFCI20A
6	074190	1	OUTLET 20A 125V NEMA L5-20R
7	080410	1	REC BLK FACE GFCI20A
8	081508U	1	CIRCT BRK 90 X 3 480V UL SQ D
9	081503U	1	CIRCT BRK 40 X 3 480V UL SQ D
10	075207D	2	CIRCT BRK 15X2 UL/CSA SANG MAO
11	055920	2	SWITCH SPST SPADE PNL MNT
12	091989	2	ASSEMBLY LUG BLOCK
14	0A9766	1	HARNESS RCP PNL GR25

ITEM	PART NO.	QTY.	DESCRIPTION
15	078436	6	SCREW PPHM #8-32 X 1/2 SS
16	080490	12	WASHER FLAT #8 SS
17	078437	6	WASHER LOCK #8-M4 SS
18	078438	6	NUT HEX #8-32 SSTL
19	085294	8	SCREW RHMS #10-32 X 4 SS
20	090427	16	WASHER FLAT #10 SS
21	040295	8	WASHER LOCK #10 SS
22	040292	8	NUT HEX #10-32 SSTL
23	085296	18	SCREW HHC 1/4-20 X 1/2 SS
24	084929	18	WASHER FLAT 1/4 SS
25	083896	18	WASHER LOCK 1/4-M6 SS
26	026579	6	WASHER SHAKEPROOF EXT #8 STEEL

Exploded View and Parts List

GR-25 Generator Set

Control Panel – Drawing No. 0D4164-B

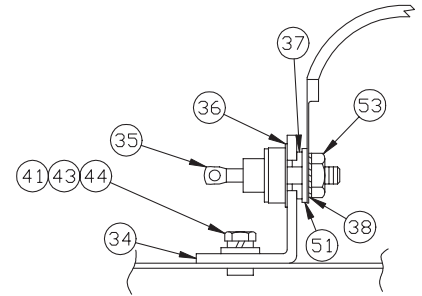
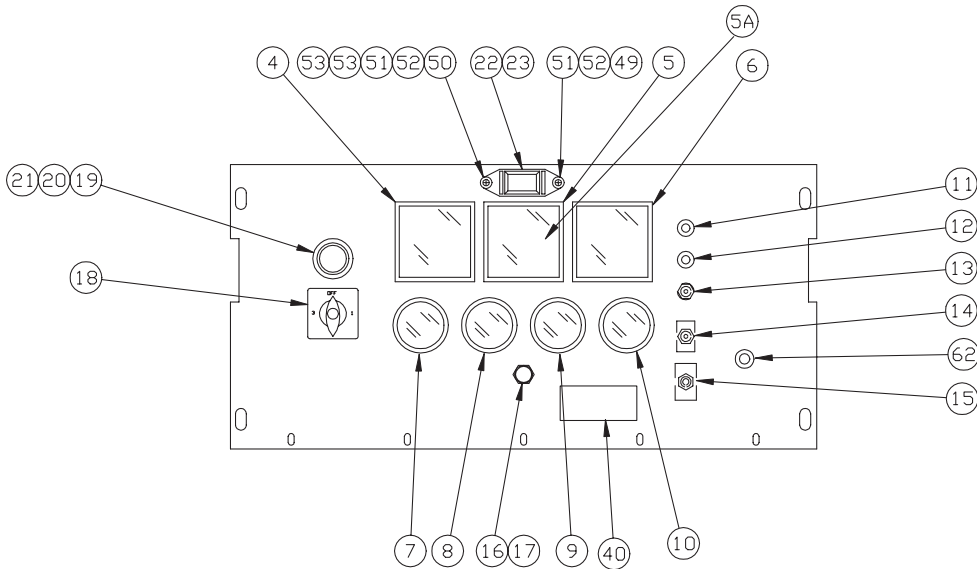
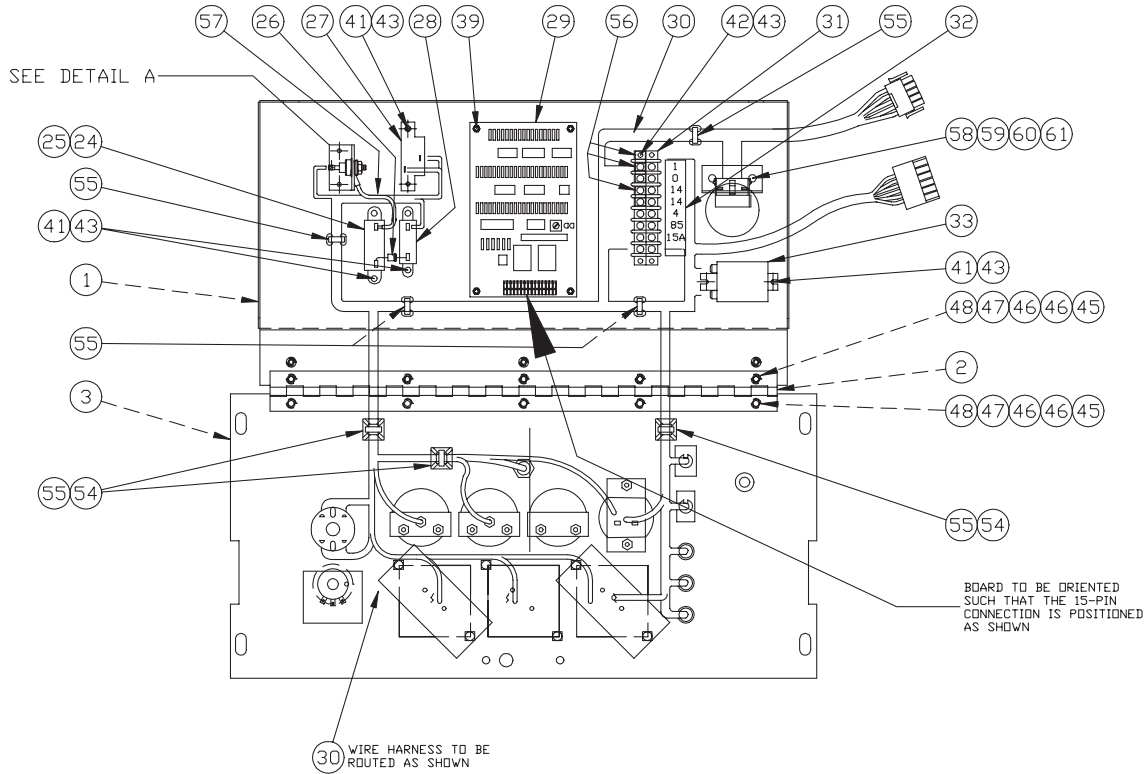

DETAIL A

Exploded View and Parts List

GR-25 Generator Set

Control Panel – Drawing No. 0D4164-B

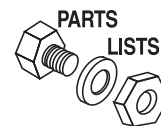

ITEM	PART NO.	QTY.	DESCRIPTION	ITEM	PART NO.	QTY.	DESCRIPTION
1	0A9205	1	SHELF CNT PNL CMPNTS	32	090513	1	DECAL-TERM.STRIP
2	0A9414	1	HINGE CNTL PNL 2.2L	33	063617	1	RELAY PNL 12VDC DPDT 10A@240VA
3	0A9069	1	PANEL CNTRL W/SLKSCR	34	055444	1	HEAT SINK
4	079983	1	VOLTMETER DUAL	35	049939	1	RECTIFIER MSC 12A 600V 1N1206R
5	070045	1	AMMETER AC 0-200	36	070370	1	WASHER MICA .203
5A	070048	1	AMMETER SCALE 0-100	37	030468	1	WASHER STEP NYLON .20
6	070042	1	METER FREQUENCY 55-65HZ	38	023762	1	WASHER SHAKEPROOF EXT #10 STL
7	055406	1	GAUGE COOLANT TEMPERATURE	39	040213	4	PCB SUPPORT SNAP-IN 1/4"
8	055405	1	GAUGE OIL PRESSURE	40	095196	1	DECAL- CHK OIL & H2O
9	062304	1	AMMETER 40-0-40 DC	41	0C2428	10	SCREW TAPTITE PH 6-32 X 1/2 Z/YC
10	070081	1	HOURMETER	42	0C2323	2	SCREW TAPTITE PH 6-32 X 5/8 ZYC
11	064009B	1	LIGHT 12VDC .02A LED GRN	43	022155	12	WASHER LOCK #6
12	064009	1	LIGHT 12VDC .02A LED RED PILOT	44	022985	2	WASHER FLAT #6 ZINC
13	055920	1	SWITCH SPST SPADE PNL MNT	45	036917	10	SCREW PPHM #8-32 X 3/8
14	061694	1	SWITCH TOG SPDT 6A SPD CTR OFF	46	038150	20	WASHER FLAT #8 ZINC
15	061943	1	SWITCH TOG DPST 15A SPD PROG	47	022264	10	WASHER LOCK M4
16	032300	1	HOLDER FUSE	48	022471	10	NUT HEX #8-32 STEEL
17	022676	1	FUSE 15A X AGC15	49	033138	1	SCREW HHM #10-32 X 5/8
18	061945	1	SWITCH SELECTOR 6A AMP/V	50	033147	1	SCREW HHM #10-32 X 1
19	050123	1	KNOB PLASTIC .25 SHAFT	51	023897	3	WASHER FLAT #10 ZINC
20	055349	1	INSULATOR	52	022152	2	WASHER LOCK #10
21	053693	1	POT 10K 10% 2.25W PANEL MT	53	022158	3	NUT HEX #10-32 STEEL
22	070202	1	LIGHT PANEL #26306C	54	057593	3	CABLE TIE MOUNT BLACK
23	070082	1	BLOCKER LIGHT	55	028739	7	TIE WRAP 3.9" X .10" NAT'L UL
24	057405	1	RES 25R 5% 25W	56	046669	3	BLOCK TERM JUMPER FOR S141
25	064733	2	BRACKET RESISTOR MNTNG FOR 25W	57	090126W	1	LOOSE WIRE
26	025192	1	RECTIFIER MSC 2A 600V 1N5062	58	0C2479	1	BRACKET 15 PIN
27	048512	1	CIRCT BRK 5 X 1 ETA 46-500-P	59	090388	2	SCREW TAPTITE M6-1.0 X 12 BP
28	044213	1	RES 10R 5% 12W	60	022097	2	WASHER LOCK M6-1/4
29	082495	1	ASSY 12/24V ENG CNTL	61	022473	2	WASHER FLAT 1/4 ZINC
30	0A9764	1	HARNESS CNTL PNL GR25	62	022717A	1	GROMMET 3/8 X 1/16 X 1/4
31	057701	1	BLOCK TERM 20A 8 X 6 X 1100V				



Exploded View and Parts List

GR-25 Generator Set

Generator Assembly — Drawing No. 0C3179-F

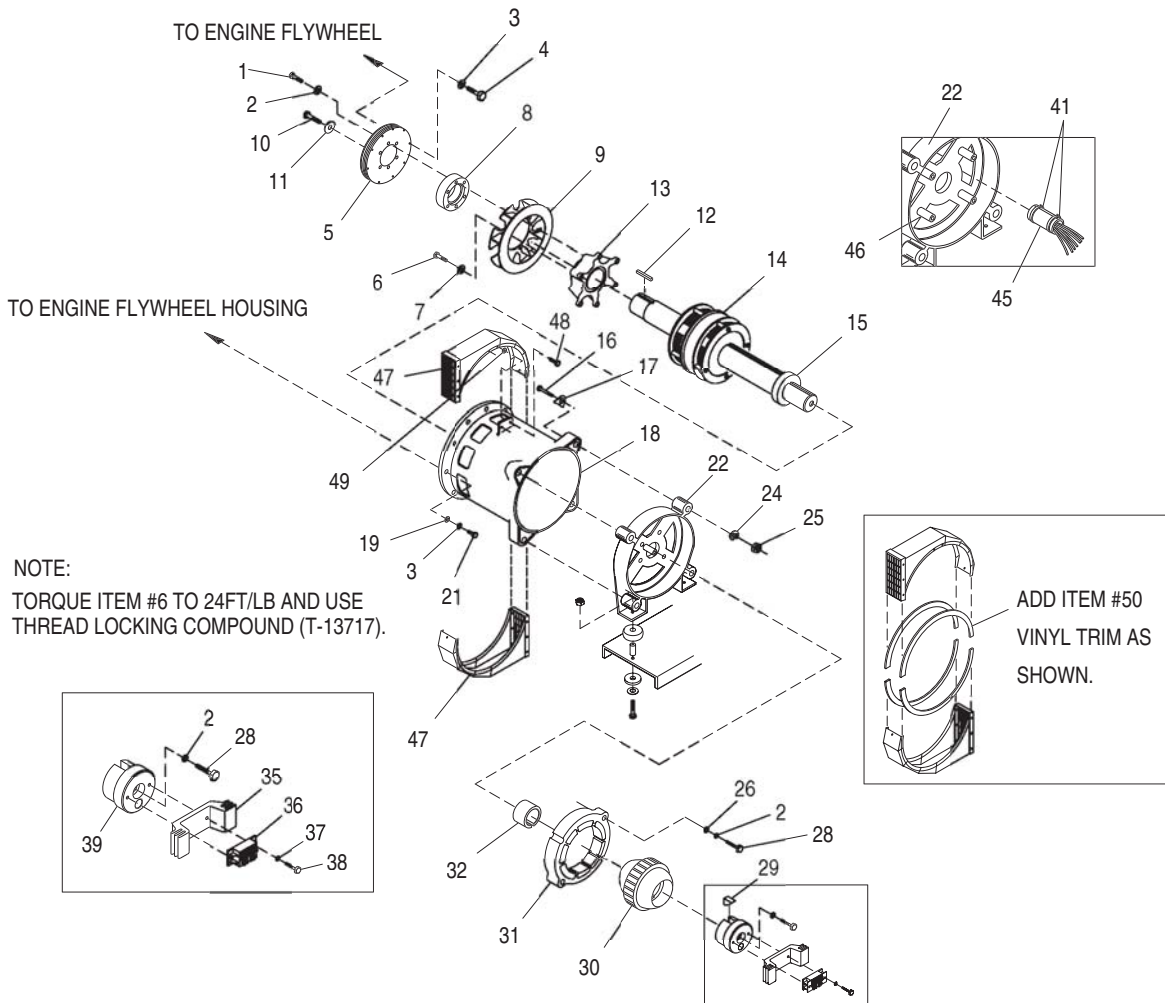

NOTE:

TORQUE ITEM #6 TO 24FT/LB AND USE
THREAD LOCKING COMPOUND (T-13717).

ITEM	PART NO.	QTY.	DESCRIPTION	ITEM	PART NO.	QTY.	DESCRIPTION
1	098780	6	SCREW HHC M12-1.75 X 65 G8.8	24	043123	4	WASHER LOCK M14
2	051769	9	WASHER LOCK M12	25	051779	4	NUT HEX M14-2
3	046526	20	WASHER LOCK M10	26	052259	2	WASHER FLAT M12
4	052647	8	SCREW SHC M10-1.5 X 25 G12.9	28	068406	3	SCREW HHC M12-1.75 X 60 G10.9
5	0A8240	2	FLEX PLATE SAE 10, 2.2L	29	070274	1	KEY SQ 3/8 X 2-3/4 STEEL
6	055173	6	SCREW HHC M8-1.25 X 20 G10.9	30	087271	1	ASSY EXCITER 1.25"STK
7	022129	6	WASHER LOCK M8-5/16	31	068404	1	EXCITER FLD 1.25 STK
8	0C1473	1	SPACER 2.2 390 ALTER	32	092950	1	COLLAR SLIP FIT 390 MM
9	0E2747	1	FAN S.A.E. ALTERNATOR	35	090063	1	BRIDGE SUPPORT DIODE 15"
10	0A2601	1	SCREW HHC M16-2 X 45 G8.8	36	090152	1	ASSY BRIDGE RECTIFIER
11	0A2602	1	WASHER FLAT .688ID X 3.25OD	37	023365	2	WASHER SHAKEPROOF INT #8
12	0A1138	1	KEY SQ 3/8 X 2-1/2 STEEL	38	033143	2	SCREW HHM #8-32 X 7/8
13	021941	1	COUPLER 390 SAE	39	090064	1	CAP END ROTOR 390MM
14	020804K	1	RTR-390--25QB1 DVSAE	41	031980	2	TIE WRAP 14.6" X .14" NATL UL
15	052624	1	BEARING BALL 6212 SEALED	45	083549	1	SLEEVE RUBBER
16	0A5580	4	SCREW HHC M14-2 X 140 G8.8	46	022392	2	PIN DOWEL 1/2 X 1-1/4
17	0A1633	4	WASHER, 390 SAE ALT.	47	0A4089	1	ASSY SCROLL 390 SAE
18	020715L	1	STR-390--25QB1 SAE	48	0A7215	2	SCREW SW 1/4-20 X 5/8 NYWA JS500
19	022131	12	WASHER FLAT M10-3/8 ZINC	49	022473	2	WASHER FLAT M6-1/4 ZINC
21	057642	12	SCREW HHC M10-1.5 X 40 G8.8	50	056326	8.4'	TRIM VINYL BLACK 1/8 GP
22	068113	1	CARRIER REAR BRG 15"				

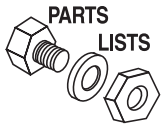

Exploded View and Parts List

GR-25 Generator Set

Radiator Assembly – Drawing No. 0A9565-E

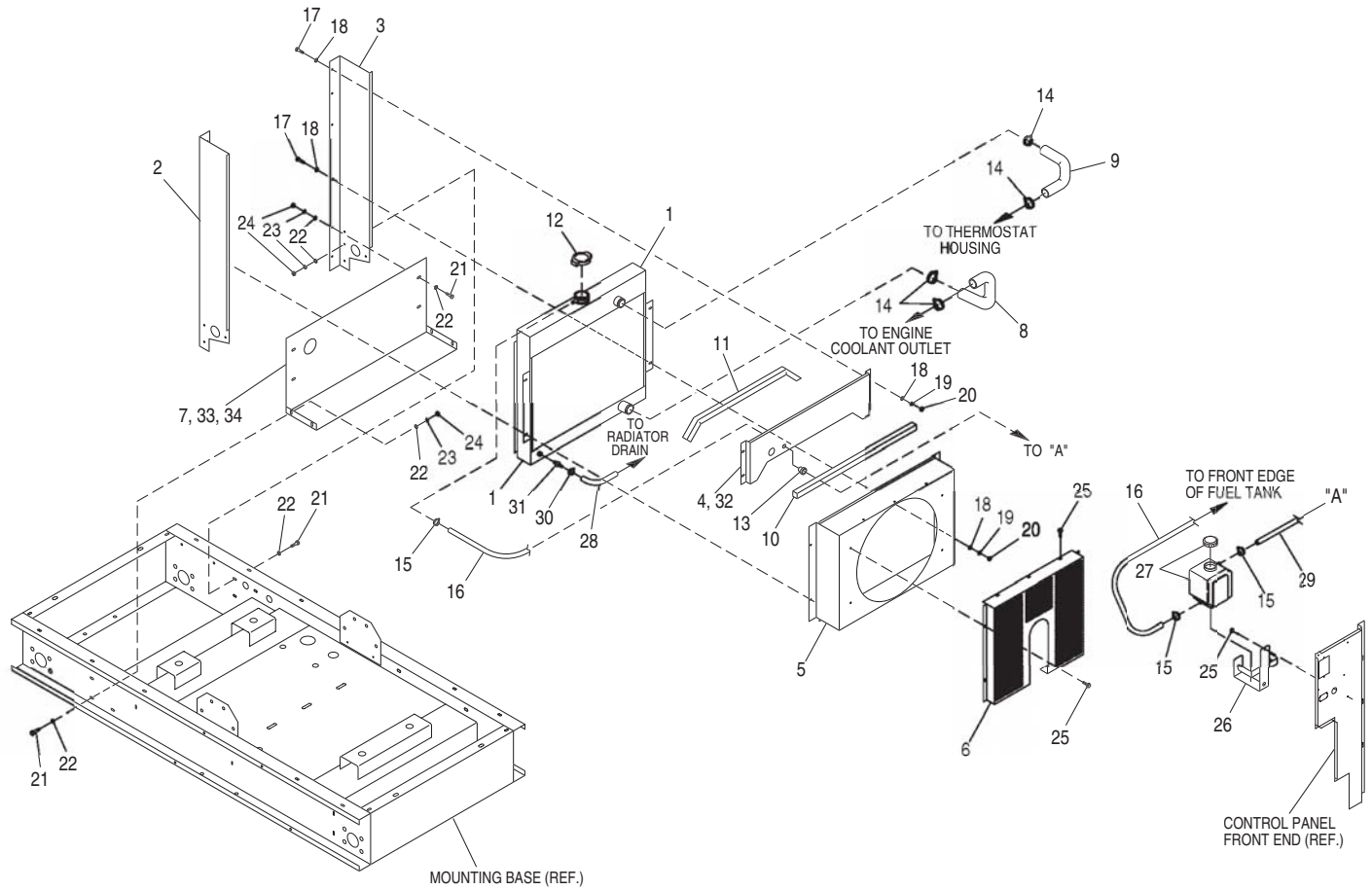

ITEM	PART NO.	QTY.	DESCRIPTION	ITEM	PART NO.	QTY.	DESCRIPTION
1	068928B	1	RADIATOR 14FIN GRIFN	19	022097	8	WASHER LOCK M6-1/4
2	0A8477	1	SUPPORT RAD. LH SIDE	20	049813	8	NUT HEX M6-1.0 G8 YEL CHR
3	0A8477A	1	SUPPORT RAD. RH SIDE	21	0A6928	18	SCREW HHC M8-1.25 X 20 SS G8.8
4	0A8478	1	AIR SEAL FRONT	22	022145	36	WASHER FLAT 5/16 ZINC
5	0A8496	1	VENTURI 2.2L ISUZU	23	022129	18	WASHER LOCK M8-5/16
6	0A8642	1	FAN GUARD, 2.2L ISUZU	24	045771	18	NUT HEX M8-1.25 G8 YEL CHR
7	0A8813	1	AIR SEAL FRONT BOTTOM	25	058443	8	SCREW CRIMPTITE 1/4-20 X 5/8
8	0A9034	1	RAD. HOSE BOTTOM 2.2	26	080712	1	BRACKET COOLANT RECOVERY TANK
9	0A9033	1	RAD. HOSE UP - 2.2L	27	076749	1	TANK COOLANT RECOVERY
10	052250	28"	TAPE FOAM 1 X 1	28	047290	30"	HOSE 3/8 ID SINGLE BRAID
11	052250	28"	TAPE FOAM 1 X 1	29	047290	54"	HOSE 3/8 ID SINGLE BRAID
12	046627	1	CAP RADIATOR	30	040173	1	CLAMP HOSE #5.5 .62 - .62
13	023484E	1	BUSHING SNAP SB-687-8	31	058043	1	BARBED STR 1/4 NPT X 5/16
14	057824	4	CLAMP HOSE #16 .87 - 1.50	32*	0A9125000A	1	AIR SEAL UPPER RAD
15	083709	3	CLAMP WIRE HOSE .573 - .551	33*	0A9125000B	1	AIR SEAL BOTM RAD
16	047290	67"	HOSE 3/8 ID SINGLE BRAID	34*	0A9125000C	1	AIR SEAL LOWER RAD
17	047411	8	SCREW HHC M6-1.0 X 16 G8.8				
18	022473	16	WASHER FLAT 1/4 ZINC				

* KIT COMPONENTS P/N 0A9125

Exploded View and Parts List

GR-25 Generator Set

Muffler – Drawing No. 0A9555-C

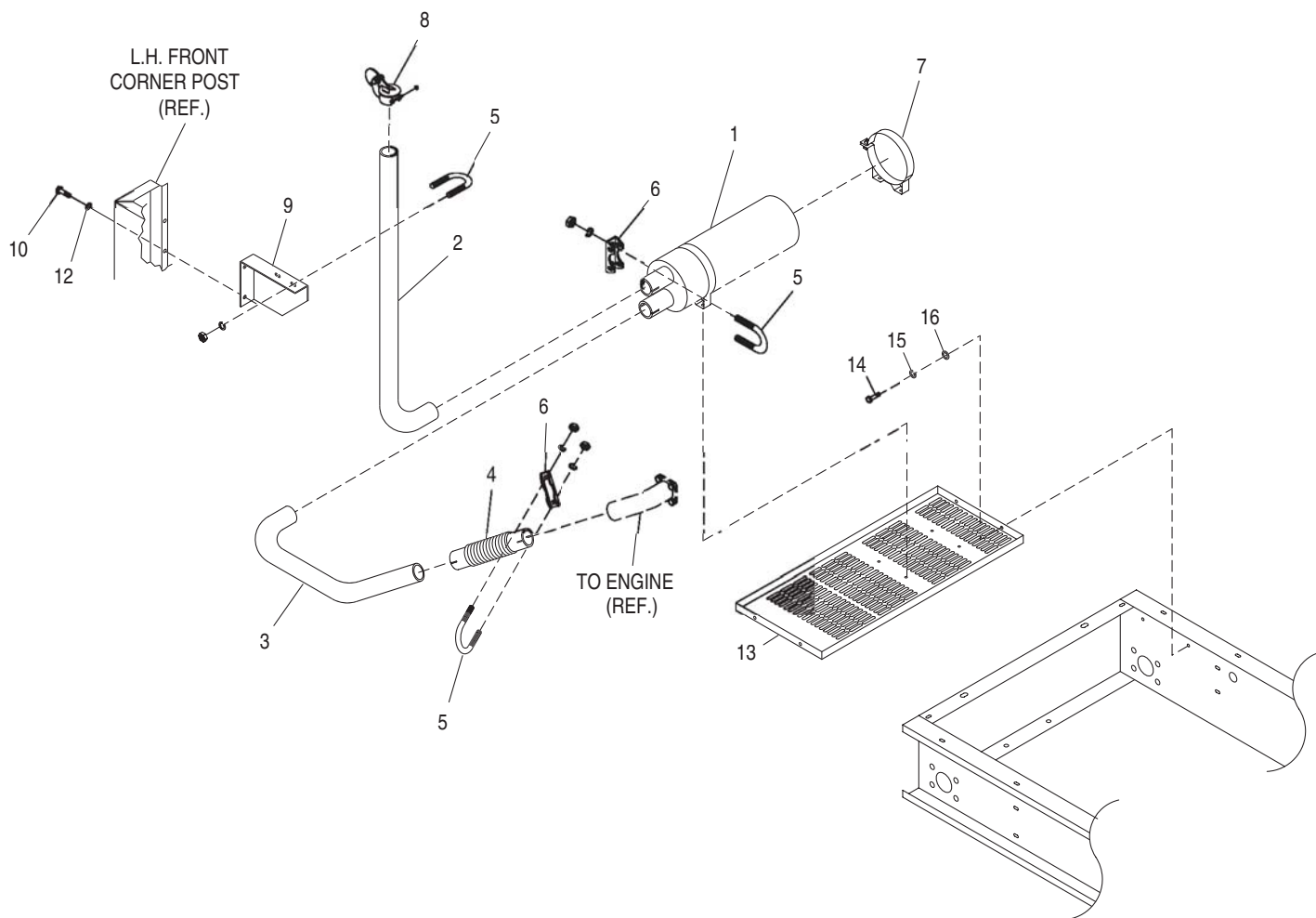
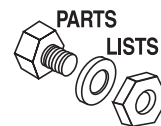

ITEM	PART NO.	QTY.	DESCRIPTION
1	0A8891	1	MUFFLER 2"IN-OUT 6"OD
2	0A8806	1	EXH TUBE (MUFF-ROOF)
3	0A8805	1	EXH TUBE (FLEX -MUF)
4	0A5215A	1	FLEX PIPE, 2"
5	036434	5	BOLT U 5/16-18 X 2.09
6	036449	4	SADDLE 2 INCH
7	060366	2	MUFFLER STRAP 6IN DIA
8	0A8974	1	CAP RAIN 2"
9	0A9035	1	BRACKET,MUFFLER SUPP
10	039253	2	SCREW HHC M8-1.25 X 20 G8.8
12	090977	2	WASHER FLAT .375ID X .875OD
13	0A8565	1	SUPPORT,MUFFLER 2.2L
14	0A6928	4	SCREW HHC M8-1.25 X 20 SS G8.8
15	022129	4	WASHER LOCK M8-5/16
16	022145	4	WASHER FLAT 5/16-M8 ZINC



Exploded View and Parts List

GR-25 Generator Set

Battery Charger – Drawing No. 0D4687-C

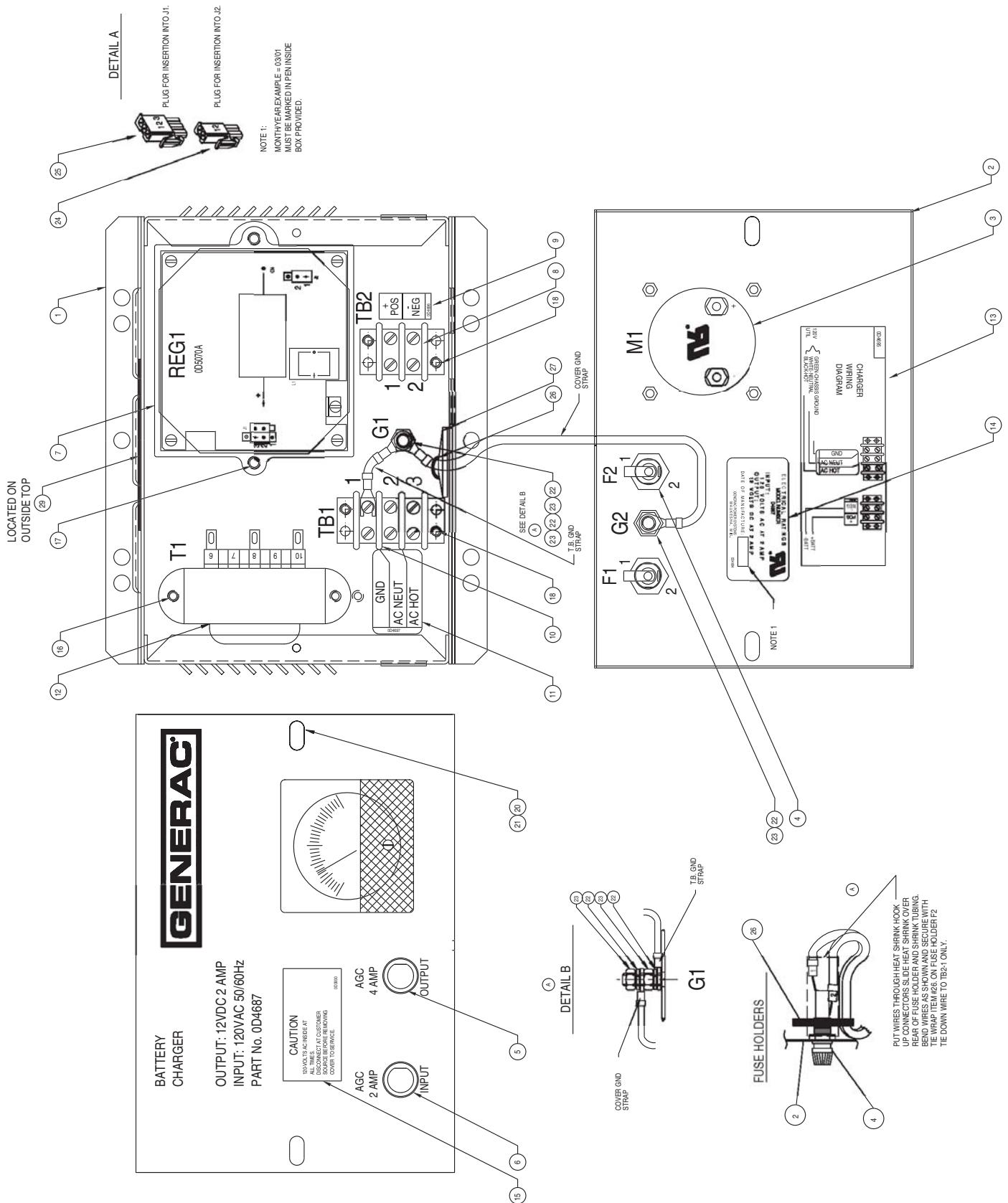

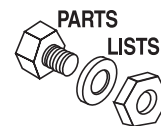
Exploded View and Parts List**GR-25 Generator Set****Battery Charger – Drawing No. 0D4687-C**

ITEM	PART NO.	QTY.	DESCRIPTION
1	0D4689	1	ENCLOSURE,2A UL CHARGER
2	0D4690	1	COVER,SILKSCREENED,12V,2A,UL
3	062060	1	AMMETER 0-5A DC 1/4FAST-ON TAB
4	032300	2	HOLDER FUSE
5	067682B	1	FUSE 4A SLO BLO GLASS
6	086310	1	FUSE 2A X AGC2
7	0D5070A	1	ASSY,2A 12V,UL BATTERY CHARGER
8	048766	1	BLOCK TERM 20A 2 X 6 X 1100V
9	0D4696	1	DECAL,2POS TERM,2A UL CHARGER
10	0D4698	1	TERMINAL BLOCK 3POS UL
11	0D4697	1	DECAL,3POS TERM,2A UL CHARGER
12	0D4707	1	TRANSFORMER, 16V CT 56VA UL
13	0D4695	1	DECAL,WIRING DIAG,2A UL CHARGE
14	0D4694	1	DECAL,RATING,12V,2A,UL,CHARGER
15	0D3930	1	DECAL, CAUTION BATT CHRГ 12/24
16	0A1495	2	SCREW HHTT M4-0.7 X 10 BP
17	066849C	2	SCREW HHTT M5-0.8 X 30 BP
18	0C2323	4	SCREW PHTT #6-32 X 5/8 ZYC
19	080858	2	SHRINK TUBING .625"ID BLK
20	052621	2	WASHER NYLON .200
21	056893	2	CRMP TIT 10-24 X 1/2
22	022097	3	WASHER LOCK M6-1/4
23	049813	3	NUT HEX M6-1.0 G8 YEL CHR
24	097234B	1	CONN PLUG FREE 2P
25	097234L	1	CONN PLUG FREE 3P
26	064761	3	TIE WRAP UL 5.6 X .10 NATL
27	057593	1	CABLE TIE MOUNT BLACK
28	0D4687W	1	WIRE-BATERY CHRГ 12V 2A UL
29	0D7551	1	DECAL WARNING BATTERY

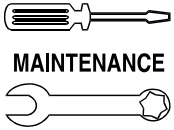

MAINTENANCE

GR-25 Generator Set

GENERAC® POWER SYSTEMS SCHEDULED MAINTENANCE AND SERVICE INFORMATION

8 KW - 35 KW SMALL STANDBY GENERATOR SETS

Following is a recommended maintenance schedule for Generac small standby and residential generator sets from 8 kW to 35 kW in size, and applies to both diesel engine and gas engine driven units. The established intervals in the schedule are the *maximum* recommended when the unit is used in an average service application. They will need to be decreased (performed more frequently) if the unit is used in a severe application. Use the unit hour meter or calendar time, whichever occurs first, from the previous maintenance interval to determine the next required maintenance interval.

Service Maintenance Interval Information:

The various service maintenance intervals are designated by interval numbers as follows:

- 1 An early inspection of the generator set to insure it is ready to operate when required and to identify any potential problem areas.

Performed monthly or following each 10 hours of operation of the unit and requires approximately .5 man-hours per unit to complete.

This inspection may be performed by the end user providing the following safety steps are taken to prevent the engine from starting automatically without warning:

To prevent injury, perform the following steps in the order indicated before starting any maintenance:

- **Disable the generator set from starting and/or connecting to the load by setting the control panel Auto-Off-Manual switch to the “OFF” position.**
- **Remove the control panel fuse.**
- **Turn off the battery charger.**
- **Remove the negative battery cable.**

The battery charger must be turned off BEFORE removing the battery cable to prevent an over current condition from burning out sensitive control panel components and circuits.

Following all maintenance, reverse these steps to insure the unit is returned to standby setup for normal operation when required.

- 2 A break-in service inspection of the generator set to insure it is ready to operate and carry the load when required, and to identify any potential problem areas.

*Performed **ONLY ONCE** following the first three months or the first 30 hours of operation after purchase of the unit and requires approximately 2.5 man-hours per unit to complete.*

This inspection contains some maintenance tasks which require special tools, equipment, and/or knowledge to accomplish and should be performed only by an authorized Generac Service Dealer.

- 3 An operational inspection of the generator set to insure it is ready to operate and carry the load when required, and to identify any potential problem areas.

Performed semi-annually or following each 50 hours of operation of the unit and requires approximately 1.5 man-hours per unit to complete.

This inspection contains some maintenance tasks which require special tools, equipment, and/or knowledge to accomplish and should be performed only by an authorized Generac Service Dealer.

- 4 A mid-level inspection of the generator set to insure it is ready to operate and carry the load when required, and to identify any potential problem areas.

Performed annually or following each 100 hours of operation of the unit and requires approximately 4.0 man-hours per unit to complete.

This inspection contains some maintenance tasks which require special tools, equipment, and/or knowledge to accomplish and should be performed only by an authorized Generac Service Dealer.

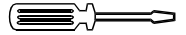

MAINTENANCE

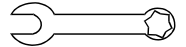

GENERAC POWER SYSTEMS, INC.

RECOMMENDED SCHEDULED MAINTENANCE PROGRAM

SERVICE WORK TO BE PERFORMED BY FACTORY-TRAINED PERSONNEL ONLY.

DEALER INFORMATION

NAME: _____
 ACCOUNT #: _____
 ADDRESS: _____

 PHONE: _____
 TECHNICIAN: _____
 SIGNATURE: _____

OWNER INFORMATION

NAME: _____
 ADDRESS: _____

 SITE: _____
 PHONE: _____
 SIGNATURE: _____

PURCHASE DATE: _____ START-UP DATE: _____

APPLICATION: ___ Standby Power ___ Prime Power ___ Rental/Trailerized

GENERATOR & TRANSFER SWITCH INFORMATION

GENERATOR

MODEL NUMBER: _____
 SERIAL NUMBER: _____

TRANSFER SWITCH

MODEL NUMBER: _____
 SERIAL NUMBER: _____

HOURLY METER READING *at Completion of the Inspection*: _____

▲ WARNING! ▲

To prevent injury, perform the following steps in the order indicated before starting any maintenance:

- Disable the generator set from starting and/or connecting to the load by setting the control panel Auto-Off-Manual switch to the "OFF" position.
- Remove the control panel fuse.
- Turn off the battery charger.
- Remove the negative battery cable.

NOTE:

The battery charger must be turned off BEFORE removing the battery cable to prevent an over current condition from burning out sensitive control panel components and circuits.

Following all maintenance, reverse these steps to insure the unit is returned to standby setup for normal operation when required.

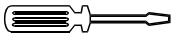

MAINTENANCE

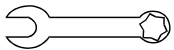

GR-25 Generator Set

GENERAC® POWER SYSTEMS SCHEDULED MAINTENANCE AND SERVICE INFORMATION

Maintenance Tasks	Level 1	Task Comp. (Date-Initials)	Level 2	Task Comp. (Date-Initials)	Level 3	Task Comp. (Date-Initials)	Level 4	Task Comp. (Date-Initials)
	Recommended to be done monthly/ 10 hrs.		Required to be done 3 months/ Break-in 30 hrs.		Required to be done Semi-annually/ 50 hrs.		Required to be done Annually/ 100 hrs.	
1. Disable the unit from operating per the first page warning.	<input type="checkbox"/>		<input type="checkbox"/>		<input type="checkbox"/>		<input type="checkbox"/>	
2. Check the engine oil level. Adjust as necessary.	<input type="checkbox"/>		<input type="checkbox"/>		<input type="checkbox"/>		<input type="checkbox"/>	
3. Check the engine coolant level. Adjust as necessary.	<input type="checkbox"/>		<input type="checkbox"/>		<input type="checkbox"/>		<input type="checkbox"/>	
4. Check the engine coolant thermal protection level. Correct as necessary.							<input type="checkbox"/>	
5. Check the natural gas delivery system on gas engine driven units. Tighten connections as necessary.			<input type="checkbox"/>		<input type="checkbox"/>		<input type="checkbox"/>	
6. Check the diesel fuel supply level for diesel engine driven units. Fill as necessary.	<input type="checkbox"/>		<input type="checkbox"/>		<input type="checkbox"/>		<input type="checkbox"/>	
7. Drain water and sediment from the diesel fuel tank on diesel engine driven units.			<input type="checkbox"/>		<input type="checkbox"/>		<input type="checkbox"/>	
8. Drain water from the fuel line water separator on diesel engine driven units if the unit is equipped with one.			<input type="checkbox"/>		<input type="checkbox"/>		<input type="checkbox"/>	
9. Check the air inlets and outlets for debris. Clean as necessary.	<input type="checkbox"/>		<input type="checkbox"/>		<input type="checkbox"/>		<input type="checkbox"/>	
10. Check the battery electrolyte level if accessible. Adjust as necessary.	<input type="checkbox"/>		<input type="checkbox"/>		<input type="checkbox"/>		<input type="checkbox"/>	
11. Check the battery posts, cables, and charger for loose connections, corrosion, and proper operation. Correct as necessary.	<input type="checkbox"/>		<input type="checkbox"/>		<input type="checkbox"/>		<input type="checkbox"/>	
12. Check the unit wiring for loose connections, corrosion, and damage. Correct as necessary.							<input type="checkbox"/>	
13. Check the engine accessory drive belts for wear, weather cracking, and damage. Replace as necessary.							<input type="checkbox"/>	

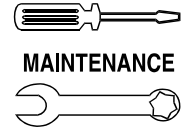

Maintenance Tasks	Level 1	Task Comp. (Date-Initials)	Level 2	Task Comp. (Date-Initials)	Level 3	Task Comp. (Date-Initials)	Level 4	Task Comp. (Date-Initials)
	Recommended to be done monthly/ 10 hrs.		Required to be done 3 months/ Break-in 30 hrs.		Required to be done Semi-annually/ 50 hrs.		Required to be done Annually/ 100 hrs.	
14. Visually inspect the unit looking for leaks, wear or damage, loose connections or components, and corrosion. Correct as necessary.	○		○		○		○	
15. Test the engine and transfer switch safety devices. Correct and/or adjust as necessary.							○	
16. Initiate an automatic start and transfer of the unit to site load and exercise it for at least 1 hour looking for leaks, loose connections or components, and abnormal operating conditions. Correct as necessary.			○		○			
17. Start and exercise the unit at full rated load (use a load bank if the site load is not enough) for at least 2 hours looking for leaks, loose connections or components, and abnormal operating conditions. Correct as necessary.							○	
18. Change the engine oil.			○				○	
19. Replace the engine oil filter(s).			○				○	
20. Replace the engine air filter(s).							○	
21. Replace the engine fuel filter(s) on diesel engine driven units and re-prime the fuel system.			○				○	
22. Check the engine spark plugs on gas engine driven units. Clean and re-gap or replace as necessary.			○				○	
23. Perform a 5 minute no-load operational run of the unit looking for any post service problems.			○				○	
24. Return the unit to standby setup for operation when required.	○		○		○		○	



Warranty

GR-25 Generator Set

GENERAC POWER SYSTEMS STANDARD TWO-YEAR LIMITED WARRANTY FOR GR SERIES/PRIME POWER UNITS

NOTE: ALL UNITS MUST HAVE A STARTUP INSPECTION PERFORMED BY AN AUTHORIZED GENERAC DEALER.

For a period of 2 (two) years or 3,000 (three thousand) hours of operation from the date of sale, which ever occurs first, Generac Power Systems, Inc. will, at its option, repair or replace any part(s) which, upon examination, inspection, and testing by Generac Power Systems or a Generac Power Systems Authorized Warranty Service Facility, is found to be defective under normal use and service, in accordance with the warranty schedule set forth below. Any equipment that the purchaser/owner claims to be defective must be returned to, and examined by the nearest Generac Power Systems Authorized Warranty Service Facility. All transportation costs under the warranty, including return to the factory, are to be borne and prepaid by the purchaser/owner. This warranty applies only to Generac Power Systems Generators used in "Prime Power/Mobile" applications, as Generac Power Systems, Inc. have defined Prime Power/Mobile, provided said generator has been initially installed and inspected on-site by a Generac Power Systems Authorized Service Dealer or branch thereof. A scheduled maintenance agreement with a local Authorized Generac Power Systems Dealer is highly recommended to verify adequate service has been performed on the unit throughout the warranty period. Limited to, and available only on Liquid-cooled units.

WARRANTY SCHEDULE

YEAR ONE — 100% (one hundred percent) coverage on mileage*, labor, and parts listed.

• **ALL COMPONENTS**

YEAR TWO — 100% (one hundred percent) coverage on parts listed.

• **ALL COMPONENTS — *PARTS ONLY**

- *Travel allowance is limited to 300 miles maximum, or 7.5 hours maximum (per occurrence), **round trip**, to the nearest Generac Service Facility.
- A Generac Power Systems, Inc. Transfer Switch is highly recommended to be used in conjunction with the genset. If a Non - Generac Power Systems, Inc. Transfer Switch is substituted for use and directly causes damage to the genset, no warranty coverage shall apply.
- All warranty expense allowances **are** subject to the conditions defined in Generac Power Systems Warranty, Policies, and Procedures Flat Rate Manual.
- Trailer/Mobile units that have been resold **are** covered under the Generac Power Systems Warranty, as this Warranty **is** transferable. A transfer fee of \$100.00 plus a complete inspection report that indicates the unit has been maintained and is in proper working order, **must be** received within 30 days of the date of sale or all warranty on the unit **will be** null and void. The warranty time frame is from the original in-service/start-up date of the unit provided all fees and documentation have been completed.

THIS WARRANTY SHALL NOT APPLY TO THE FOLLOWING:

1. Any unit built/manufactured prior to January 1, 2002.
2. Unit enclosure is only covered against rust or corrosion the first year of the warranty provision.
3. Costs of normal maintenance i.e. tune-ups, associated part(s), adjustments, loose/leaking clamps, installation and start-up.
4. Use of Non-Generac replacement part(s) will void the warranty in its entirety.
5. Any failure caused by contaminated fuels, oils, coolants/antifreeze or lack of proper fuels, oils or coolants/antifreeze.
6. Units sold, rated or used for "Standby Power" applications as Generac Power Systems have defined Standby Power. Contact a Generac Power Systems Distributor for Standby Power definition and warranty.
7. Failures due, but not limited to, normal wear and tear, accident, misuse, abuse, negligence, or improper installation or sizing.
8. Failures caused by any external cause or act of God such as collision, fire, theft, freezing, vandalism, riot or wars, lightning, earthquake, windstorm, hail, volcanic eruption, water or flood, tornado, hurricane, terrorist acts or nuclear holocaust.
9. Products that are modified or altered in a manner not authorized by Generac Power Systems in writing.
10. Any incidental, consequential or indirect damages caused by defects in materials or workmanship, or any delay in repair or replacement of the defective part(s).
11. Failure due to misapplication, misrepresentation, or bi-fuel conversion.
12. Telephone, telegraph, teletype or other communication expenses.
13. Living or travel expenses of person(s) performing service, except as specifically included within the terms of a specific unit warranty period.
14. Rental equipment used while warranty repairs are being performed i.e. rental generators, cranes, etc..
15. Overtime labor or more than one person performing repairs.
16. Any and all expenses incurred investigating performance complaints unless defective Generac materials and or workmanship were the direct cause of the problem.
17. *Engine coolant heaters (block-heaters), heater controls and circulating pumps after the first year.
18. *Starting batteries, fuses, light bulbs, engine fluids, and overnight freight cost for replacement part(s).

THIS WARRANTY IS IN PLACE OF ALL OTHER WARRANTIES, EXPRESSED OR IMPLIED, SPECIFICALLY, GENERAC POWER SYSTEMS MAKES NO OTHER WARRANTIES AS TO THE MERCHANTABILITY OR FITNESS FOR A PARTICULAR PURPOSE. Some states do not allow limitations on how long an implied warranty lasts, so the above limitation may not apply to you.

GENERAC POWER SYSTEMS ONLY LIABILITY SHALL BE THE REPAIR OR REPLACEMENT OF PART(S) AS STATED ABOVE. IN NO EVENT SHALL GENERAC POWER SYSTEMS BE LIABLE FOR ANY INCIDENTAL, OR CONSEQUENTIAL DAMAGES, EVEN IF SUCH DAMAGES ARE A DIRECT RESULT OF GENERAC POWER SYSTEMS, INC. NEGLIGENCE. Some states do not allow the exclusion or limitation of incidental or consequential damages, so the above limitations may not apply to you. Purchaser/owner agrees to make no claims against Generac Power Systems, Inc. based on negligence.

This warranty gives you specific legal rights. You also may have other rights that vary from state to state.

GENERAC® POWER SYSTEMS, INC. · P.O. BOX 8 · WAUKESHA, WI 53187
PH: (262) 544-4811 · FAX: (262) 544-4851

Bulletin 0166300SBY / Printed in USA 5.02