

GENERAC[®]

POWER SYSTEMS, INC.

GR-210

Operation and Maintenance Manual

Standby Output 170 kW (213 kVA)
Prime Output 165 kW (206 kVA)

Liquid-cooled
Diesel Engine
Generator Set

Model No. 004366-1

**Optional Dual Axle Trailer
Model No. 004601-0**

**Optional Installation
of Factory Trailer
Model No. 4608-0**

*** This Manual Should Remain With The Unit ***

INTRODUCTION

This Owner's Manual was prepared especially for the purpose of familiarizing personnel with the operation and servicing of the applicable equipment.

Every effort was expended to make sure that the information and instructions in the Manual are accurate and current at the time the Manual was written. However, the manufacturer reserves the right to change, alter or otherwise improve product(s) at any time without prior notice.



CAUTION: Read all instructions and safety rules before attempting to operate or service this (and related) equipment. Protect yourself and others by strictly complying with these instructions and rules. Failure to comply with these safety rules may result in personal injury, death or damage to equipment and/or property. Retain these instructions for future reference.

■ READ THIS MANUAL THOROUGHLY

If you do not understand any portion of this manual, contact Generac or your nearest Generac Authorized Service Dealer for starting, operating and servicing procedures.

Throughout this publication, and on tags and decals affixed to the generator, DANGER, WARNING, CAUTION and NOTE blocks are used to alert you to special instructions about a particular operation that may be hazardous if performed incorrectly or carelessly. Observe them carefully.

These safety warnings cannot eliminate the hazards that they indicate. Common sense and strict compliance with the special instructions while performing the service are essential to preventing accidents.

The following definitions apply to DANGER, WARNING, CAUTION and NOTE blocks found throughout the manual.



DANGER: After this heading, you can read handling, installing, operating or servicing instructions that, if not strictly complied with, will result in personal injury.



WARNING: After this heading, you can read handling, installing, operating or servicing instructions that, if not strictly complied with, may result in personal injury.



CAUTION: After this heading, you can read instructions for handling, installing, operating or servicing the generator that, if not strictly complied with, could result in damage to equipment and/or property.

NOTE: After this heading, you can read explanatory statements that require special emphasis.

These symbols indicate the following:



Points out important safety information that, if not followed, could endanger personal safety and/or property.



Points out potential explosion hazard.



Points out potential fire hazard.



Points out potential electrical shock hazard.

The operator is responsible for proper and safe use of the equipment. Generac strongly recommends that the operator read this *Owner's Manual* and thoroughly understand all instructions before using this equipment. Generac also strongly recommends instructing other users to properly start and operate the unit. This prepares them if they need to operate the equipment in an emergency.

■ OPERATION AND MAINTENANCE

It is the operator's responsibility to perform all safety checks, to make sure that all maintenance for safe operation is performed promptly, and to have the equipment checked by an authorized dealer periodically. Normal maintenance service and replacement of parts are the responsibility of the owner/operator and, as such, are not considered defects in materials or workmanship within the terms of the warranty. Individual operating habits and usage contribute to the need for maintenance service.

Proper maintenance and care of the generator ensures a minimum number of problems and keeps operating expenses at a minimum. See a Generac authorized dealer/distributor for service aids and accessories.

■ HOW TO OBTAIN SERVICE

When the generator set requires servicing or repairs, simply contact an authorized service facility for assistance. Service technicians are factory-trained and are capable of handling all service needs.

When contacting an authorized service facility or the factory about parts and service, always supply the complete model number, serial number, and vin number of unit as given on its data decal.

The warranty on the generator is included in this *Owner's Manual*, as well as listings for repair parts.

<p>INTRODUCTIONInside Front Cover</p> <p> Read This Manual Thoroughly Inside Front Cover</p> <p> Operation and Maintenance Inside Front Cover</p> <p> How to Obtain Service Inside Front Cover</p> <p> Service Dealer Location 1</p> <p>SAFETY RULES2</p> <p>IDENTIFICATION RECORD4</p> <p> Data Plate4</p> <p>EQUIPMENT DESCRIPTION4</p> <p> Standard Generator Features4</p> <p> Generator Specifications.....4</p> <p> Engine Specifications4</p> <p>INSTALLATION5</p> <p> Standby Electric System.....5</p> <p>EMERGENCY CIRCUIT ISOLATION6</p> <p>TOTAL CIRCUIT ISOLATION6</p> <p>PREPARATION BEFORE USE7</p> <p> Engine Lubrication7</p> <p> Engine Coolant7</p> <p> Fuel7</p> <p> Cord Sets - 120 Volts GFCI Duplex Receptacles.....7</p> <p> 120 Volt, 20 Amp Locking Type Receptacle8</p> <p> 120/208 to 139/240 Volts, 50 Amp Locking Type Receptacle.....8</p> <p> Full Capacity Terminal Compression Lugs8</p> <p> Transfer Switch Terminal9</p> <p> Grounding the Generator10</p> <p> Grounding the Generator Neutral10</p> <p> Starting Battery10</p> <p>SWITCHES, METERS AND LIGHTS10</p> <p> AC Voltmeter10</p> <p> AC Ammeter11</p> <p> Frequency Meter11</p> <p> Coolant Temperature Gauge.....11</p> <p> Oil Pressure Gauge11</p> <p> DC Ammeter11</p> <p> Hourmeter11</p> <p> System Ready Lamp11</p> <p> Fault Indicator Lamp11</p> <p> Pre-Heat Switch11</p> <p> Auto/Off/Manual Switch11</p> <p> Start/Run/Off Switch12</p> <p> Panel Light12</p> <p> Voltage Adjust Dial12</p> <p> Phase Selection Switch12</p>	<p>ENGINE PROTECTIVE DEVICES.....12</p> <p> Low Oil Pressure Switch.....12</p> <p> High Coolant Temperature Switch12</p> <p> Low Coolant Level Sensor12</p> <p> DC Control/Latch-Crank Circuit Board13</p> <p> Engine Startup13</p> <p> After Fault Shutdown13</p> <p> Overspeed.....13</p> <p> Overcrank Shutdown.....13</p> <p>OPERATING INSTRUCTIONS13</p> <p> Before Starting13</p> <p> Starting the Engine13</p> <p> Shut Down13</p> <p> Operation In Ice Or Snow13</p> <p> Ground Fault Protection14</p> <p>MAINTENANCE14</p> <p> 100-Hour Break In14</p> <p> 100-Hour Break In Period14</p> <p>RECOMMENDED ENGINE FLUIDS15</p> <p> Engine Oil15</p> <p> Engine Coolant15</p> <p> Supplemental Coolant Additives.....15</p> <p> Fuel15</p> <p>CHECKING FLUID LEVELS15</p> <p> Engine Oil15</p> <p> Engine Coolant16</p> <p> Fuel.....16</p> <p>OWNER/OPERATOR PERIODIC MAINTENANCE.....16</p> <p>BLEEDING THE FUEL SYSTEM.....17</p> <p>PERIODIC MAINTENANCE LIST17</p> <p> Daily17</p> <p> Every 50 Hours or 2 Weeks17</p> <p> Every 250 Hours or 6 Months.....17</p> <p> Every 600 Hours or 12 Months.....17</p> <p> Every 1200 Hours or 24 Months.....17</p> <p> Every 2000 Hours17</p> <p>ADJUSTMENT OF FUEL INJECTION TIMING.....17</p> <p>ENGINE SPEED ADJUSTMENT.....17</p> <p>VOLTAGE REGULATOR ADJUSTMENT18</p> <p>GENERATOR ROTOR BEARING18</p> <p>MAJOR REPAIRS18</p> <p> How to Order Parts18</p> <p>WIRING DIAGRAMS/SCHEMATICS19</p> <p>EXPLODED VIEWS28</p> <p>WARRANTIES47</p>
---	--

SERVICE DEALER LOCATION

TO LOCATE THE NEAREST GENERAC SERVICING DEALER, PLEASE CALL OUR 800 NUMBER.
ONLY DEALER LOCATION INFORMATION CAN BE OBTAINED AT THIS NUMBER.

1-800-333-1322



Important Safety Instructions

GR-210 Generator Set

⚠ THE MANUFACTURER SUGGESTS THAT THESE “RULES” FOR SAFE OPERATION BE COPIED AND POSTED IN POTENTIAL HAZARD AREAS. SAFETY SHOULD BE STRESSED TO ALL OPERATORS AND POTENTIAL OPERATORS OF THIS EQUIPMENT.

⚠ WARNING: ⚠

The engine exhaust from this product contains chemicals known to the state of California to cause cancer, birth defects or other reproductive harm.

⚠ WARNING: ⚠

This product contains or emits chemicals known to the state of California to cause cancer, birth defects or other reproductive harm.

Study these “SAFETY RULES” carefully before installing, operating or servicing this equipment. Become familiar with the Owner’s Manual and with the unit. The generator can operate safely, efficiently and reliably only if it is properly set up, operated and maintained. Many accidents are caused by failing to follow simple and fundamental rules or precautions.

Generac cannot possibly anticipate every possible circumstance that might involve a hazard. The warnings in this manual, and on tags and decals affixed to the unit, are, therefore, not all-inclusive. Make sure the procedure, work method or operating technique that is chosen does not render the generator unsafe.

⚠ DANGER: Despite the safe design of this generator set, operating this equipment imprudently, neglecting its maintenance or being careless can cause possible injury or death. Permit only responsible and capable persons to operate or maintain this equipment.

⚠ DANGER: Generator sets can be dangerous. Only suitably qualified personnel should attempt to install or work on this type of equipment.

⚡ DANGER: Potentially lethal voltages are generated by these machines. Ensure all steps are taken to render the machine safe before attempting to work on the generator set.

⚠ DANGER: Parts of the generator set are rotating and/or hot during operation. Exercise care near running generator sets.



⚠ For safety reasons, Generac recommends that the initial start-up of this equipment is carried out by a Generac Authorized Dealer.

- Adequate, unobstructed flow of cooling and ventilating air is critical to correct generator set operation. Do not alter the installation or permit even partial blockage of ventilation provisions, as this can seriously affect safe operation of the generator set.
- Diesel engine exhaust fumes contain carbon monoxide, which can be DEADLY. This dangerous gas, if breathed in sufficient concentrations, can cause unconsciousness or even death. This exhaust system must be properly installed, in strict compliance with applicable codes and standards. Following installation, do nothing that might render the system unsafe or make it non-compliant with such codes and standards. Inspect the exhaust system regularly to ensure that it is free from leaks and damage, and that it is not possible for fumes to enter any area where people or animals are located. Never operate this equipment with a leaking or defective exhaust system. Repair or replace any damaged or leaking component immediately.
- Keep hands, feet, clothing, etc., away from drive belts, fans, and other moving or hot parts. Never remove any drive belt or fan guard while the unit is operating.
- When working on this equipment, remain alert at all times. Never work on the equipment when you are physically or mentally fatigued.
- Before performing any maintenance on the generator set, disconnect its battery cables to prevent accidental start up. Disconnect the cable from the battery post indicated by a NEGATIVE, NEG or (-) first. When reconnecting the battery, connect the NEGATIVE, NEG or (-) last.
- This generator set may be capable of automatic, unattended operation, and may start and run at any time. To prevent possible injury under such conditions, NEVER work on a generator in automatic mode. Before commencing work, select the control system to "OFF," disconnect generator starting battery and isolate any other sources of electrical power to the machine (such as battery charger or engine heater supplies).
- Never use the generator or any of its parts as a step. Stepping on the unit can stress and break parts, and may result in dangerous operating conditions from leaking exhaust gases, fuel leakage, oil leakage, etc.
- Inspect the generator set regularly, and repair or replace all damaged or defective parts immediately.
- Remove the fuse from the battery charger before disconnecting the battery to minimize the chance of equipment damage.



-  **For fire safety, the generator must be installed and maintained properly. Installation always must comply with applicable codes, standards, laws and regulations. Adhere strictly to local, state and national electrical and building codes. Comply with regulations the Occupational Safety and Health Administration (OSHA) has established. Also, ensure that the generator is set up in accordance with the manufacturer's instructions and recommendations. Following proper set up, do nothing that might alter a safe installation and render the unit in noncompliance with the aforementioned codes, standards, laws and regulations.**

 - Keep a fire extinguisher near to the generator set at all times. Extinguishers rated "ABC" by the National Fire Protection Association are appropriate for use on generator sets and are useful for small fires. For more sophisticated fire protection systems, contact your local fire department for advice, or contact a specialist fire protection company.
-  **The generator set covered by this manual produces dangerous electrical voltages and can cause fatal electrical shock. Avoid contact with bare wires, terminals, connections, etc., while the unit is running. Ensure all appropriate covers, guards and barriers are in place before operating the generator set. If you must work around an operating unit, stand on an insulated, dry surface to reduce shock hazard.**

 - The National Electric Code (NEC) requires the frame and external electrically conductive parts of the generator set to be connected to an approved earth ground. Local electrical codes also may require proper grounding of the generator electrical system.
- Operation of the generator set in damp or wet locations can be extremely hazardous. Electrical resistance to current is reduced whenever items become wet.
 - Never wear jewelry or watches when working on this equipment. Jewelry and watches can conduct electricity resulting in electric shock, or may get caught in moving components causing injury.
-  **In case of accident caused by electric shock, immediately shut down the source of electrical power. If this is not possible, attempt to free the victim from the live conductor. AVOID DIRECT CONTACT WITH THE VICTIM. Use a nonconducting implement, such as a board or a rope, to free the victim from the live conductor. If victim is unconscious, apply first aid and get immediate medical help.**
-  **Do not smoke around the generator set. Wipe up any fuel or oil spills immediately. Ensure that no combustible materials are left on or near the generator set, as FIRE or Explosion might result. Keep the area surrounding the generator set clean and free from debris.**

 - Diesel fuel can be hazardous. Regularly inspect the installation for leaks and rectify them immediately.

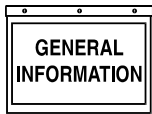

General Information

GR-210 Generator Set

IDENTIFICATION RECORD

DATA PLATE

Every generator has a DATA PLATE which contains important information pertinent to the generator. The data plate lists the unit's serial number, its rated voltage, amps, wattage capacity, phase, frequency, rpm, power factor, etc.

Generator Model Number: This number is the key to numerous engineering and manufacturing details pertaining to your unit. Always supply this number when requesting service, ordering parts, or seeking information.

Voltage Code X: The GR Series generators are capable of supplying a variety of single-phase and 3-phase voltages, in total referred to as an X voltage code. They include the following:

- 120/208 to 139/240 volts, single phase, 60 Hz.
- 120/208 to 139/240 volts, 3-phase, 60 Hz.
- 240/416 to 277/480 volts, 3-phase, 60 Hz.

Note:

The above voltage ratings are stated in the form, V_{ph}/V_L .

— V_{ph} is the phase voltage (i.e., voltage above neutral).

— V_L is the line-to-line voltage.

EQUIPMENT DESCRIPTION

This equipment is a revolving field, alternating current generator set. The generator is designed to supply electrical power for the operation of compatible, electrical loads when Utility Power is unavailable.

The generator's revolving field is directly connected to and driven by an engine by means of flexible discs and a coupling assembly. Units with 4-pole rotors are driven at speeds of 1800 rpm to supply a rated frequency of 60 Hz.

The unit can be equipped with an optional dual axle highway transportable trailer (Model No. 004601-0) equipped with breakaway safety chains and a jack stand. The trailer may be installed either at the factory using Model No. 004608-0 or shipped separately for freight savings.

STANDARD GENERATOR FEATURES

This generator incorporates the following features:

- The unit meets temperature rise standards for Class "F" insulation as defined by NEMA MG1-22.40, NEMA MG1-1.65 and NEMA MG1-1-66.
- The generator is self-ventilated and drip-proof constructed.

- The voltage waveform deviation, total harmonic content of the AC waveform and "telephone influence factor" have been evaluated and are acceptable according to NEMA MG1-22.
- A state of the art magnetic circuit provides minimal level of waveform distortion and an electro-magnetic interference level which meets accepted requirements for standard AM radio, TV and marine radio telephone applications.

GENERATOR SPECIFICATIONS

Refer to the DATA PLATE on your particular generator for rated watts (kW), rated maximum amperes, rated AC frequency, rated voltage, number of phases and other pertinent information.

ENGINE SPECIFICATIONS

General

Type	Diesel
Cylinders and Arrangement	6, in-line
Displacement	8.1 Liter (496 inches ³)
Bore	116mm (4.56 inches)
Stroke	129mm (5.06 inches)
Compression Ratio	16.5 to 1
Intake Air	Turbo Charged
No. of Main Bearings	7
Governed Engine Speed	See DATA PLATE
Maximum Horsepower at 1800 rpm	250
Engine Lubrication System	
Type of Oil Pump	Gear
Oil Filter	Full Flow Cartridge
Crankcase Oil Capacity	31 liters (8.2 U.S. quarts)
Cooling System	
Type	Pressurized, closed recovery
Coolant Capacity	
System	20.5 liters (5.4 U.S. gallons)
Engine	14 liters (3.7 U.S. gallons)
Radiator	6.5 liters (1.75 U.S. gallons)
Coolant Flow Per Minute	
At 1800 rpm	270 liters (71 U.S. gallons)
Heat Rejection to Coolant	370,200 BTU/hr.
Cooling Fan	Pusher type
Diameter of Fan	711mm (28 inches)
Intake Air Flow Required	
60 Hz.	16 m ³ /min.
Exhaust System	
Exhaust Flow at Rated Output	
60 Hz.	42 m ³ /min. (1480 cfm)
Exhaust Temperature at Rated Output	545°C (1015°F)
Engine Electrical System	
DC Alternator Output	55 amps at 12 volts
Starter Motor	12 volt DC
Recommended Battery	(1) 12 volt, 135 A.H., 4DLT
Ground Polarity	Negative (-)

Fuel Consumption

Model	50%	75%	100%	Standby
GR210 at 60 Hz. (gph)	5.5	8.2	11.0	12.3
(liters per hour)	20.8	31.0	41.6	46.5

INSTALLATION

STANDBY ELECTRIC SYSTEM

A standby electric system may be defined as a system in which the generator is used to operate critical electrical loads normally powered by a utility power source when the utility power source fails or is not present.

- If you are going to use the units to operate electrical loads in standby system applications, the units may be used up to their rated capacity. If the total electrical power demanded by all loads in a system is greater than the rated limit, only power essential or key loads (up to the stated capacity).
- Generac does not recommend installing or operating a trailer mounted generator indoors. Other units are available which are better suited for indoor installations.
- A double throw transfer switch is required in standby electric system applications to prevent electrical feedback between the generator and the utility power circuit.
- Figure 1 illustrates a typical standby electric system. Figure 2 shows a schematic diagram of such a system. The transfer switch is used to select which power supply (generator or utility) will operate load circuits in such a system. The transfer switch also prevents load circuits from being connected to both power supplies at the same time.
- If the installer has not installed a transfer switch and modified the electric system as shown in Figure 2, plug critical electrical devices (furnace, fan, sump pump, water pump, etc.) directly into one of the generator's output receptacles.

- If the electrician has installed a transfer switch and a connection box, use a suitable, approved cord set between the connection box and a suitable generator receptacle, or between the connection box and the generator's full capacity terminal studs.



DANGER: If existing electrical circuits in a building are normally powered by the utility source, the installer must provide a positive means of making sure that both power supplies never feed to the load circuits at the same time.

- Never connect the generator output to any live building circuits. If the generator is connected to any existing electrical circuit during a commercial power outage, a positive method of isolating the two power supplies must be provided. The usual method of isolating the circuits is by means of a double throw transfer switch.

Figure 2 - Simple Standby Electric System

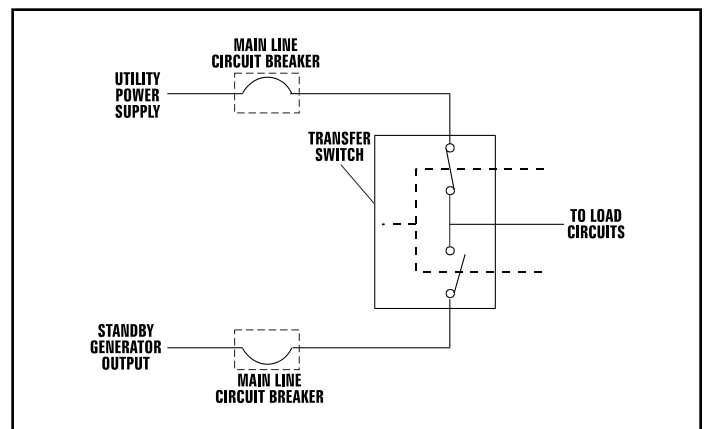
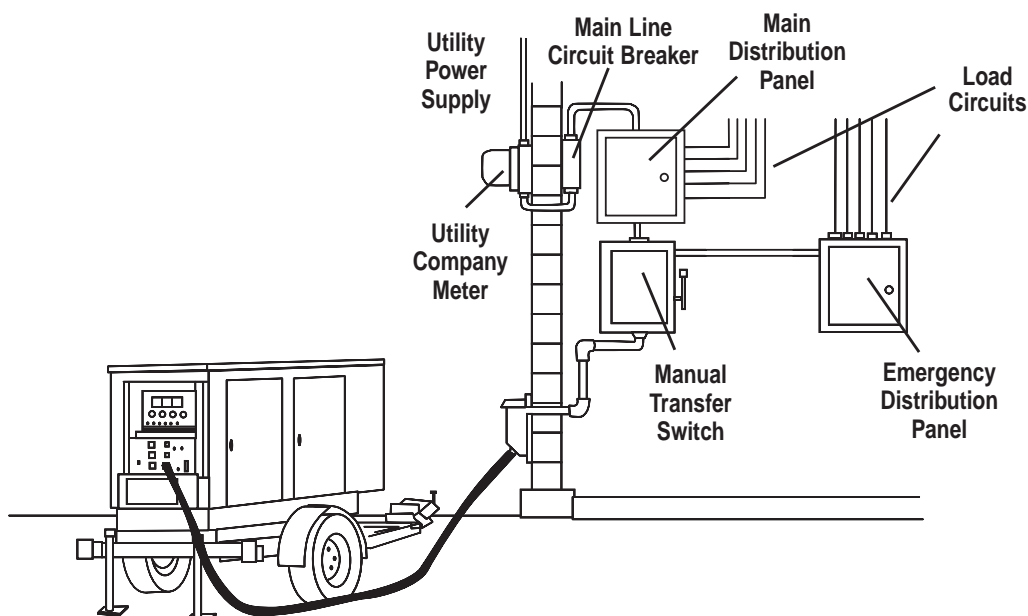

Figure 1 - Typical Standby Electric System



⚠ DANGER! A hazard exists during a power outage if the generator is connected to building circuits and no method of positively isolating the generator from the utility supply is provided.

⚡ Power company workers attempting to restore utility power will open a switch between the main power supply and the spot where they are working. If the home or building electrical circuits are not isolated from the utility supply, generator AC output will backfeed through the building electrical circuits and up the power line. A power company worker may be electrocuted.

⚡ If utility and generator power are not isolated and utility power is suddenly restored while the generator is powering load circuits, the generator can be severely damaged.

EMERGENCY CIRCUIT ISOLATION

One isolation method is to have emergency circuits (important or essential items to be powered during a utility outage) grouped together and rewired into a separate “emergency distribution panel” (Figure 3). Using this method helps prevent accidental overloading of the generator or the specific generator receptacle in use.

Loads fed by this emergency distribution panel must not exceed the wattage/amperage rating of the generator or the specific receptacle in use.

A transfer switch having an ampere rating equal to, or exceeding, the ampere rating of the emergency circuit should be connected between the building’s main electrical distribution panel and the emergency distribution panel.

Figure 3 - Emergency Circuit Isolation

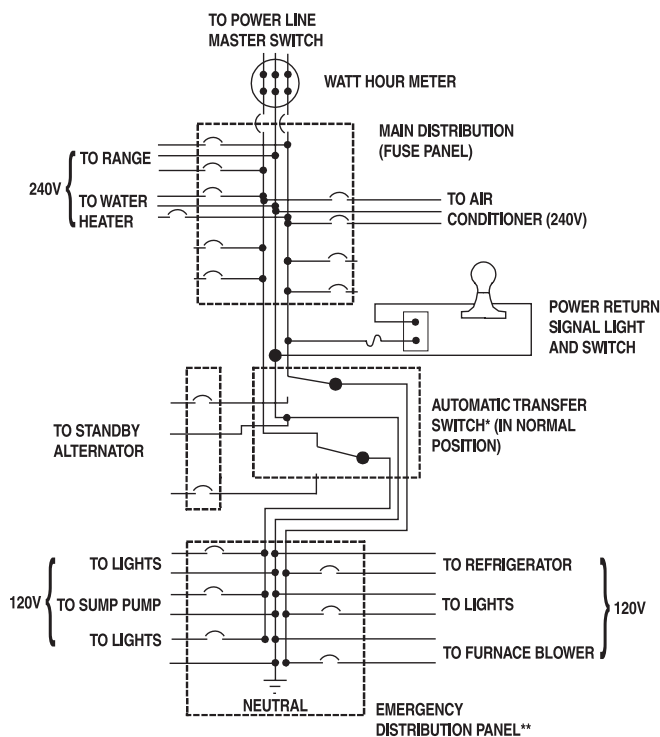

*Ampere rating must be equal to or exceed the ampere rating of the emergency distribution panels.

**Ampere capacity not to exceed the alternator rating. Only these items will be powered by the standby alternator. If the electrician sizes the load properly, the alternator cannot be overloaded.

All wiring must conform to the United States National Electrical Code (NEC) and all state and local codes. Consult a qualified licensed electrician.

The above illustration assumes the utility is supplying 120/240 volt single phase electric service.

TOTAL CIRCUIT ISOLATION

If the emergency circuits (Figure 4) are not or cannot be wired together in a separate emergency distribution panel, select the circuits and specific appliances to be powered by the generator during a utility power failure. When this is done, take care to avoid overloading the generator or generator receptacles.

When using the total circuit isolation method, the ampere rating of the transfer switch must equal the rating of the normal incoming utility service.

Figure 4 - Total Circuit Isolation Method

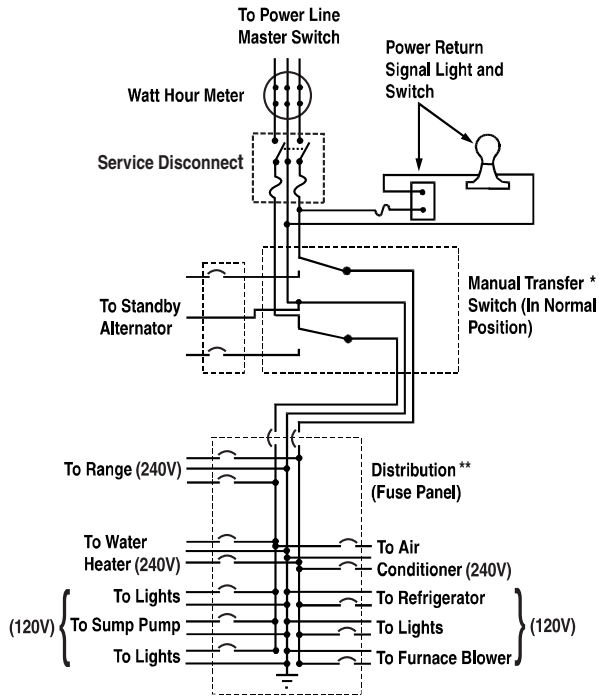

*Ampere rating must be equal to or larger than main (normal) utility entrance service.

**With this system take care to prevent overloading the alternator. During utility power failure, turn OFF individually all load items to distribution panel. Only certain items can be turned back on during alternator operation. Have your electrician specify these items so you do not overload the alternator. All wiring must conform to the United States National Electrical Code (NEC) and all state and local codes. Consult a qualified licensed electrician. The above illustration assumes the utility is supplying 120/240 volt single phase electric service.

PREPARATION BEFORE USE



CAUTION: Prior to initially starting the generator, you must properly prepare it for use. Any attempt to crank or start the engine before it has been properly serviced with the recommended oil may result in an engine failure. Also, engine coolant level must be checked and replenished if necessary.

ENGINE LUBRICATION

Check engine crankcase oil level prior to use and add oil to the proper level. See "Maintenance" section, page 15 for recommendations.

ENGINE COOLANT

Check engine coolant level and add the recommended coolant mixture as required. Refer to "Maintenance" section, page 15.

FUEL

Fill the fuel tank with the correct recommended diesel engine fuel (see "Maintenance" section, page 15). The base tank holds 264 gallons of fuel, if so equipped.

NOTE: If the unit has been idle for a long period of time or if fuel lines or fuel system components have been removed and re-installed, the fuel system may require bleeding to remove air from the system. See "Maintenance" section for fuel system bleeding procedures. Air in the fuel system causes hard starting and rough engine operation. All fuel system lines must be installed and must be tight. A loose line may show no sign of leakage, but may draw air into the system.

CORD SETS - 120 VOLT GFCI DUPLEX RECEPTACLE



CAUTION: Panel receptacles can supply only single-phase AC output. Never connect any 3-phase electrical load to a receptacle.

The generator is equipped with a 120 volt ground fault circuit interrupter (GFCI) duplex receptacle (Figure 5) on the generator receptacle panel. See "Ground Fault Protection" on Page 14. This outlet consists of a "pair" of receptacles, protected against overload by a 20-amp, push-to-reset type circuit breaker. Thus, use the receptacle pair to power 120 volts, 60 Hz, AC electrical loads requiring up to 20 AC amperes of total current.

Figure 5 - 120 V GFCI Duplex Outlet

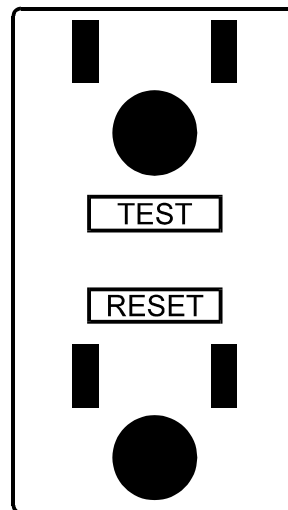

Use only high quality, well-insulated, 3-wire, grounded cord sets with the 120-volt duplex type receptacles. Cord sets should be rated 20 AC amperes at 135 volts or greater.

■ 120 VOLT LOCKING TYPE RECEPTACLE

CAUTION: Panel receptacles can supply only single-phase AC output. Never connect any 3-phase electrical load to a receptacle.

This locking type receptacle (Figure 6) is protected against ground faults with a ground fault circuit interrupter (GFCI) module. See "Ground Fault Protection" on Page 14. It is also protected against overload by a 20-amp, push-to-reset type circuit breaker. The receptacle, a NEMA L5-20R type, requires a mating NEMA L5-20P connector plug. Use only high quality, well-insulated, 3-wire, grounded cord set with connector plug. The cord set must be rated for 20 AC amperes at 135 volts (or greater) electrical loads.

Figure 6 - 120 Volt Locking Type Receptacle

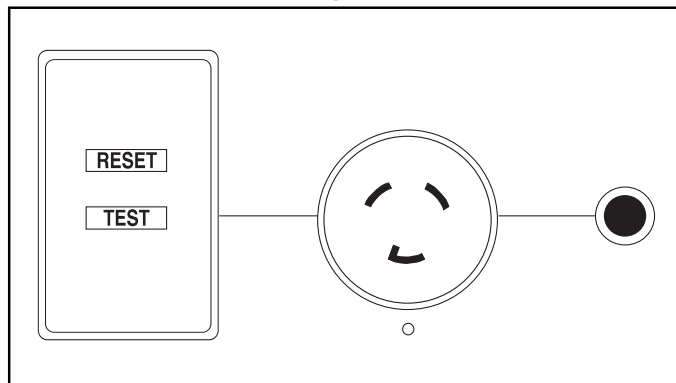

CAUTION: Any attempt to power total loads in excess of 20 amperes from the 120V receptacle pair, or the 120V locking type receptacle, will trip open a circuit breaker, removing power to both receptacles.

■ 120/208 TO 139/240 VOLTS, 50 AMP LOCKING TYPE RECEPTACLE

CAUTION: Panel receptacles can supply only single-phase AC output. Never connect any 3-phase electrical load to a receptacle.

These two receptacles are each protected against overload by two separate 50 amp, flip-to-reset type circuit breakers. These receptacles are type CS6369 and require the proper mating plugs. Use only high quality, well insulated, 3-wire, grounded cord sets with a mating 50 amp connector plugs. The cord sets used must be rated for 1-phase, 50 AC amps at 250 volts (or greater) electrical loads (Figure 7).

Figure 7 - 120/208 Volts, 50 Amp Receptacle

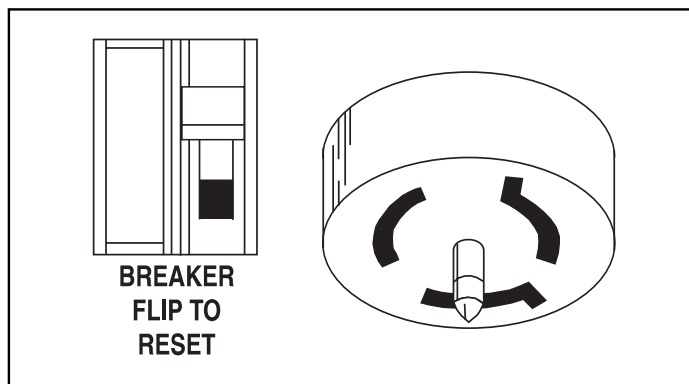

The voltage on this receptacle can be adjusted between 120/208 volts and 139/240 volts. Adjusting for 127/220 volts AC with the voltage adjustment dial is also acceptable for most 120/240 volts loads.

WARNING! Never unplug a connector plug from any panel receptacle while an electrical load is connected and turned on. Conversely, never plug a load in while that load is turned on. Dangerous electrical arcing can occur between the receptacle and the connector plug.

■ FULL CAPACITY TERMINAL COMPRESSION LUGS

Terminal compression lugs are provided in the two AC power panels (Figure 8). Four terminal studs in one panel are identified as E3, E2, E1 and N (neutral) high voltage connections. The studs for low voltage connections are labeled N (neutral), L1, L2, L3 in the second panel. These studs may be used to operate either single or three phase electrical loads at up to the full-rated wattage/amperage capacity for each mode of operation (single phase or three phase). Terminal stud AC output is limited by the generator's 700 amp main circuit breaker (CB7) for 208 volts AC loads or the 300 amp main circuit breaker (CB8) for 480 volts AC loads.

Figure 8 - High Voltage Terminal Compression Lugs

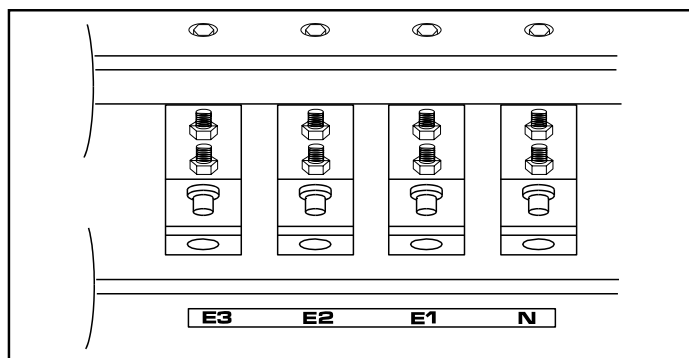

CAUTION: Although operation of single-phase loads through the terminal lugs is possible as well as the receptacles, **DO NOT** attempt to connect any 3-phase loads to the receptacles.

- Wiring cables for connecting loads to terminal studs must be rated 480 volts at 300 AC amperes (or greater) for loads on E1, E2, E3, N and 240 volts at 700 AC amperes (or greater) for loads on L1, L2 L3.
- When connecting electrical loads, be sure the voltage adjust dial is positioned to the correct voltage. The dial permits you to adjust the voltage from 120/208 volts and 240/416 volts up to 139/240 volts and 277/480 volts.

CAUTION! Voltage adjust dial affects all receptacles and terminals at the same time.

NOTE:

All receptacles and terminals are available at all times and can be loaded at the same time. **MAXIMUM TOTAL LOAD** must not exceed generator rating. Maximum load for single-phase or three-phase operation must not exceed the rating for that particular mode of operation (rating for single-phase may be less than for three-phase operation). The total load connected to any phase, including loads connected to receptacles, must not exceed the rated generator output per phase.

- Set voltage adjust dial to “120/208V” for 120 volts, single-phase or 208 volts, 3-phase when connecting for one of these voltages. See “Voltage Adjust Dial” on page 12. Connect cord set leads as follows:
 - L1 to N = 120 volt, single-phase
 - L1 to L2 = 208 volt, 3-phase
 - L2 to N = 120 volt, single-phase
 - L2 to L3 = 208 volt, 3-phase
 - L3 to N = 120 volt, single-phase
 - L3 to L1 = 208 volt, 3-phase
- Set the voltage adjust dial to “139/240V” for 139 volt, single-phase or 240 volt, 3-phase when connecting for one of these voltages. See “Voltage Adjust Dial” on page 12. Then connect cord set leads as follows:
 - L1 to N = 139 volt, single-phase
 - L1 to L2 = 240 volt, 3-phase
 - L2 to N = 139 volt, single-phase
 - L2 to L3 = 240 volt, 3-phase
 - L3 to N = 139 volt, single-phase
 - L3 to L1 = 240 volt, 3-phase

WARNING! With voltage set line-to-line for 240V, line-to-neutral voltage will be 139V at receptacles.

- Set the voltage adjust dial to “240/416V” for 240 volt, single-phase or 416 volt 3-phase when connecting for one of these voltages. See “Voltage Adjust Dial” on page 12. Then connect cord set leads as follows:

- E1 to N = 240 volt, single-phase
- E1 to E2 = 416 volt, 3-phase
- E2 to N = 240 volt, single-phase
- E2 to E3 = 416 volt, 3-phase
- E3 to N = 240 volt, single-phase
- E3 to E1 = 416 volt, 3-phase

- Set the voltage adjust switch to “277/480V” for 277 volt, single-phase or 480 volt, 3-phase when connecting for one of these voltages. See “Voltage Adjust Dial” on page 12. Then connect cord set leads as follows:

- E1 to N = 277 volt, single-phase
- E1 to E2 = 480 volt, 3-phase
- E2 to N = 277 volt, single-phase
- E2 to E3 = 480 volt, 3-phase
- E3 to N = 277 volt, single-phase
- E3 to E1 = 480 volt, 3-phase

CAUTION: Do NOT connect E1 or E2 or E3 to L1 or L2 or L3. Damage to equipment, personal injury or death may result.

DANGER: Connect cable leads to the power terminal studs only when the engine is shut down. The panel door is equipped with a push-button safety interlock switch (Figure 9) that prevents engine startup and operation while the door is open. Opening the door while engine is running immediately shuts down the engine. The switch is provided for your protection. Do not attempt to bypass or disconnect it.

TRANSFER SWITCH TERMINAL

The AC power panel includes a terminal strip for connecting an automatic transfer switch, such as a GTS transfer switch (Figure 10). This connection allows the use of the unit as a standby generator in practical applications or in emergency situations.

Figure 9 - Interlock Switch on Panel Door

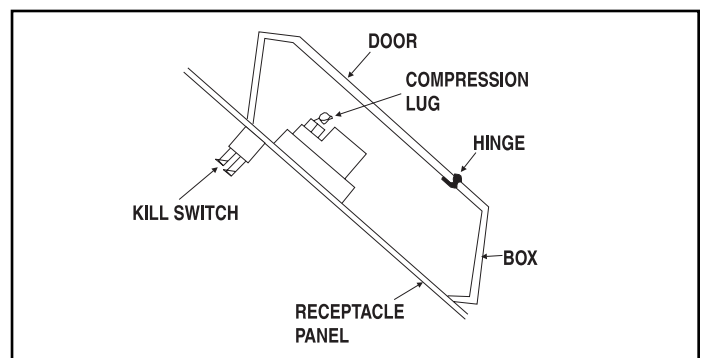
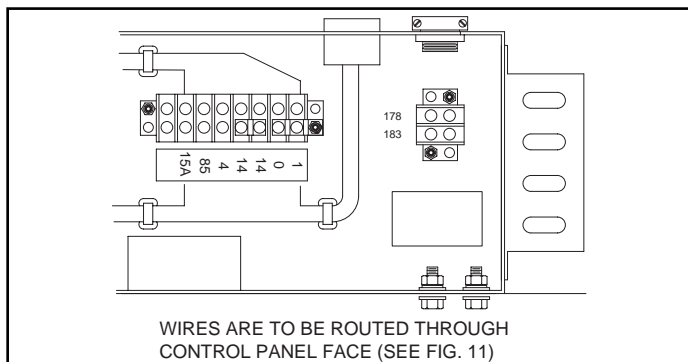

Figure 10 - Transfer Switch Terminals



GROUNDING THE GENERATOR

The National Electric Code (NEC) requires that the frame and external electrically conductive parts of the generator be properly connected to an approved earth ground. Local electrical codes may also require that the unit be grounded. Consult with a local electrician for grounding requirements in the area.

Grounding helps prevent dangerous electrical shock if a ground fault exists in the generator or connected electrical devices. Grounding also helps dissipate static electricity that often builds up in ungrounded devices. Static electricity alone can cause very painful shock and may cause one to believe that a shorted condition exists in equipment.

GROUNDING THE GENERATOR NEUTRAL

The neutral conductor of the generator may or may not need to be grounded depending if it is supplying a separately derived system or being used as a Standby electric system for an existing, utility fed electrical system.

Separately Derived System – A wiring system whose power is derived solely from the generator and that has no direct electrical connection, including a solidly connected grounded circuit conductor, to supply conductors originating in another system.

A bonding conductor is required to be installed between the neutral conductor of the generator and the ground lug mounted on the frame of the mobile generator. The neutral conductor of the generator can be accessed at either of full capacity compression lug connections. The neutral terminal is labeled “N”. Contact an electrician to determine the proper size conductor and to install the bonding conductor.

Standby Electric System – A bonding conductor is not required to be installed between the generator neutral and the generator frame. Consult an electrician to perform this installation.

STARTING BATTERY

This unit requires one 12 volt, Type 4DLT storage battery rated at 135 amp-hours (not included).

- The red battery cable (from starter contactor) should be connected to battery post indicated by a positive POS or (+).
- The black cable (from frame ground) must be connected to the battery post indicated by a negative, NEG or (—).
- The battery must be properly retained in its mounting tray, using the hardware provided.

SWITCHES, METERS AND LIGHTS

For all the components mentioned in this section, refer to Figure 11.

AC VOLTMETER

This AC voltmeter indicates the voltages for generator AC output. Also see “Voltage Adjust Dial”.

When connecting electrical loads, be sure the voltage adjust dial is positioned to the correct voltage. The voltage adjust dial permits you to adjust voltages from 120/208 volts and 240/416 volts up to 139/240 volts and 277/480 volts.

Figure 11 - Generator Control Console

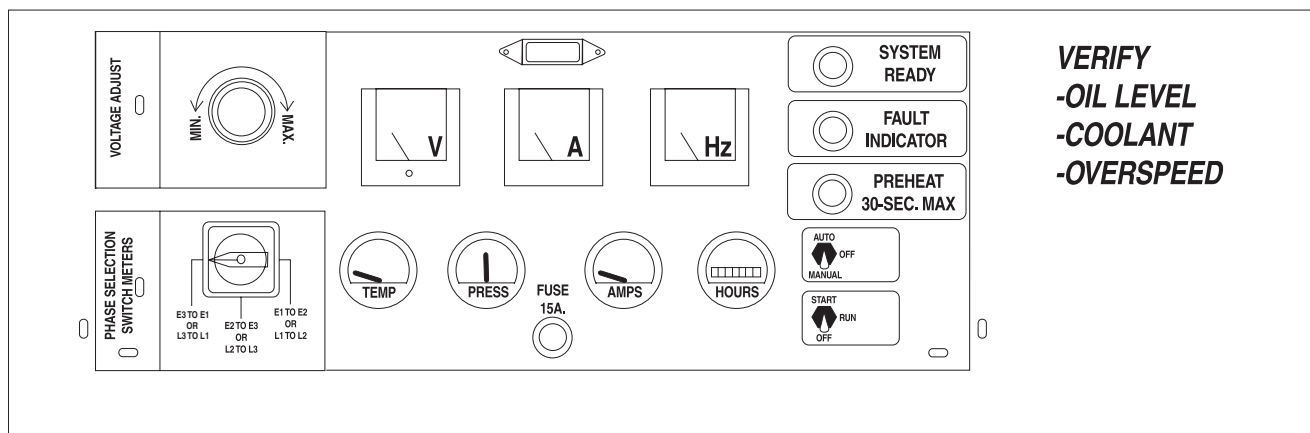

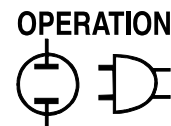

CAUTION! Voltage adjust dial affects all receptacles at the same time.

NOTE:

All receptacles and terminals are available at all times and can be loaded at the same time. **MAXIMUM TOTAL LOAD** must not exceed generator rating. **Maximum load for single-phase or three-phase operation must not exceed the rating for that particular mode of operation (rating for single-phase may be less than for three-phase operation). The total load connected to any phase, including loads connected to receptacles, must not exceed the rated generator output per phase.**

■ AC AMMETER

Indicates current draw of connected loads, in amps. Rated maximum continuous load current should be kept within the limits of the rated wattage capacity of the unit for single phase and for three-phase loads.

■ FREQUENCY METER

Indicates generator AC output frequency in “Hertz” (cycles per second). The generator's rated AC frequency is 60 Hertz, which is supplied at 1800 rpm. The engine governor was factory adjusted at no-load to about 1860 rpm or 62 Hertz. Maximum droop with the generator fully loaded should not be below about 59 Hertz. While operating, normal frequency is between 59-62 Hertz.

NOTE: The engine automatically shuts down and the fault indicator light goes ON if frequency exceeds about 74 Hertz (2220 rpm). This is an “overspeed” condition.

■ COOLANT TEMPERATURE GAUGE

Indicates engine coolant temperature. Coolant temperature during unit operation is about 170°-200°F. If the coolant temperature exceeds about 250°F, the engine automatically shuts down and the fault indicator light goes ON.

■ OIL PRESSURE GAUGE

Indicates engine oil pressure.

■ DC AMMETER

The engine is equipped with a belt-driven DC alternator which maintains battery state of charge while the unit is running. This ammeter indicates rate of charge to the battery while operating.

- Immediately after startup, the DC ammeter needle may swing to the right of zero (+ - charging) but should drop to zero or just slightly to the right of zero (+) within a few minutes.

- If the needle drops to the left of zero (or —), battery is discharging. Investigate and correct this problem immediately.
- If the ammeter needle fluctuates, investigate and correct immediately. Disconnect battery and control panel fuse prior to working on unit.

■ HOURMETER

Provides a continuous indication of engine-generator operating time, in hours and tenths of hours. Use the hourmeter with the periodic maintenance schedule (See “Maintenance” section, page 17).

■ SYSTEM READY LAMP

This lamp goes ON when the unit is running. The lamp will not go ON if a fault has occurred and the Start/Run/Off switch hasn't been switched to OFF to reset the fault.

■ FAULT INDICATOR

The lamp goes on if any one or more of the following automatic shutdown faults occurs:

- High coolant temperature (above about 250°F).
- Low coolant level.
- Low engine oil pressure (below 10 psi).
- Overspeed above about 74 Hz (2220 rpm).
- Overcrank

■ PRE-HEAT SWITCH

This engine comes with INTAKE AIR HEATERS to heat the combustion chamber air for quicker and easier starts. Prior to starting a cold engine manually, hold the PREHEAT switch for about 15 seconds. **DO NOT PRE-HEAT FOR MORE THAN 30 SECONDS.**

■ AUTO/OFF/MANUAL SWITCH

This safety switch should be used to prevent automatic startup of the engine when working on the engine-generator. Use the switch as follows:

- **AUTO Position:** Always set switch to AUTO for automatic system operation. This means when this generator is installed along with a GTS type automatic transfer switch, the generator automatically cranks and starts when the utility source voltage drops below a preset level.
- **OFF Position:** Engine cannot be started either automatically or manually. Always set switch to OFF before working on or around the engine-generator.
- **MANUAL Position:** Engine can be cranked and started manually using the panel Start/Run/Off switch. Engine will not start automatically.

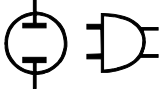

START/RUN/OFF SWITCH

To crank and start the engine, hold the Start/Run/Off switch at “Start”. When engine starts and runs at rated frequency, release the switch to its center (Run) position. To shut engine down, set the switch to the “Off” position.

PANEL LIGHT

The panel light will turn on when the unit is running or cranking.

VOLTAGE ADJUST DIAL

This potentiometer permits the operator to select the desired output voltage from the alternator. Turning the voltage adjust dial counterclockwise decreases the voltage and allows operation of loads down to 120/208 volts AC and 240/416 volts AC and a little below.

Turning the dial clockwise, operation of up to 139/240 volts and 277/480 volts AC can be achieved, as well as slightly higher loads. The generator can power any load with voltage between these two extremes including 127/220 volts AC near the center of the dial.

Note: The voltage indicated on the voltage adjust dial is line-to-line voltage (See description of “Voltage Code X”).



CAUTION! Voltage adjust dial affects all receptacles at the same time.

NOTE:

All receptacles and terminals are available at all times and can be loaded at the same time. **MAXIMUM TOTAL LOAD** must not exceed generator rating. Maximum load for single-phase or three-phase operation must not exceed the rating for that particular mode of operation (rating for single-phase may be less than for three-phase operation). The total load connected to any phase, including loads connected to receptacles, must not exceed the rated generator output per phase.

PHASE SELECTION SWITCH

This switch permits selection between the phases for which the line-to-line voltage and amperage readings are displayed on the console AC voltmeter and ammeter.

ENGINE PROTECTIVE DEVICES

Unlike an automobile, the generator may be required to run for long periods without an operator nearby to monitor engine parameters (oil pressure, temperature, engine speed, low coolant level etc.). For that reason, the unit is equipped with various protective devices which will stop the engine automatically if an operational fault occurs.

LOW OIL PRESSURE SWITCH

This normally-closed, pressure actuated switch (Figure 12) is held open by engine oil pressure during running. Should engine oil pressure drop below about 10 PSI, the switch contacts will close. When contacts close, the engine automatically shuts down and the fault indicator lamp goes ON.

Figure 12 - Low Oil Pressure Switch

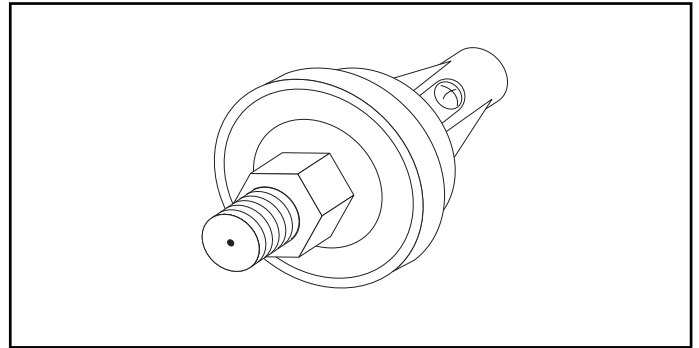

HIGH COOLANT TEMPERATURE SWITCH

This thermostatic, normally-open switch (Figure 13), is immersed in engine coolant. Should coolant temperature increase above about 250°F, the switch contacts close and an automatic shutdown occurs.

Figure 13 - High Coolant Temperature Switch

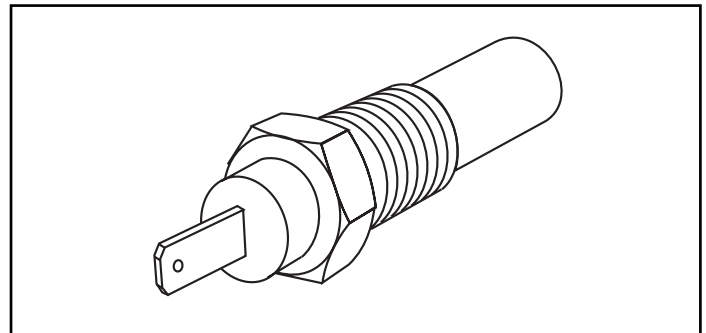

LOW COOLANT LEVEL SENSOR

If engine coolant level is low, a high temperature condition can exist without affecting the high coolant temperature switch. However, the low coolant level sensor (Figure 14) will detect the low level condition and initiate an engine shutdown.

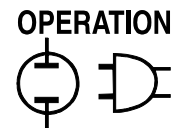
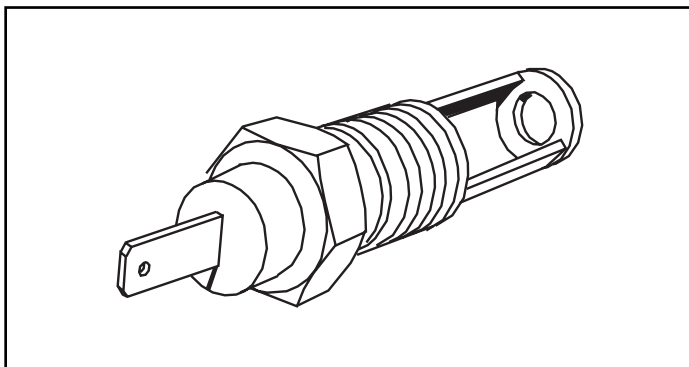

Figure 14 - Low Coolant Level Sensor



■ DC CONTROL/LATCH-CRANK CIRCUIT BOARD

The circuit board, housed inside the generator control console, controls engine starting, running and shut-down. The board provides either manual (electric) or automatic starting. It senses the generator is running by means of generator AC output.

■ ENGINE STARTUP

When the engine starts, the starter is disabled when AC output reaches about 40 volts AC (rms). Engine speed at that point has reached between 1000 to 1250 rpm.

A nominal 5-second time delay after starter cutout is provided. That is, if any one or more of the shutdown faults (low oil pressure, high coolant temperature, low coolant level, etc.) occurs 5 seconds or more after the starter cutout has occurred, the engine shuts down and the fault indicator lamp goes ON after the fault has been maintained for 2 seconds.

■ AFTER FAULT SHUTDOWN

The engine cannot start until the engine control is reset, following an automatic fault shutdown with the fault lamp ON. Reset the control by setting the Start/Run/Off switch to "Off" and then back to "Run."

■ OVERSPEED

A speed circuit controls engine cranking, start-up, operation and shutdown. Engine speed signals are delivered to the circuit board whenever the unit is running. Should the engine overspeed above a safe, preset value, the circuit board initiates an automatic engine shut-down. (About 74 Hz. or 2220 RPM)

■ OVERCRANK SHUTDOWN

If the engine fails to start after a crank cycle of 90 seconds (8 seconds on, 8 seconds off), this function will illuminate the fault indicator and stop the crank cycle.

OPERATING INSTRUCTIONS

■ BEFORE STARTING

- Prior to starting the engine, make sure the engine-generator has been properly prepared for operation as outlined in PREPARATION BEFORE USE (Pages 7-12).
- Check that both of the power panel (compression lug) doors are closed and latched. The engine will not start if any power panel door is open (Figure 9 on page 9).
- Check that the Voltage Adjust Dial is adjusted for the proper voltage that your loads require.

■ STARTING THE ENGINE

- Be sure all necessary cables are connected to the full capacity compression lugs before starting the engine (see pages 8-9). ALL electrical loads must be switched off before starting the engine (including loads connected to the receptacle panel).
- Place the Auto/Off/Manual switch in "Manual" position.
- Crank the unit by moving the Start/Run/Off switch to "Start".
- When engine starts and runs at rated Hertz, release the start switch to the "Run" position.
- Let the engine stabilize and warm up for a few minutes. Then turn on the desired electrical loads.

NOTE:

During starting, the fault indicator lamp remains ON until oil pressure builds. If any monitored shutdown occurs, restarting of the engine cannot occur until the controls have been reset. To do this, set the Start/Run/Off switch to "Off" and then back to "Run."

■ SHUT DOWN

- Turn all loads OFF.
- Let the engine run at no-load for a few minutes to stabilize internal engine temperatures.
- On the generator control console, set the Start/Run/Off switch to "Off". Wait for the engine to come to complete stop.

■ OPERATION IN ICE OR SNOW

If the generator has been exposed to freezing rain or snow, be sure to inspect the air inlet and outlet areas in the compartment. Do not operate the unit if snow or ice have blocked or obstructed the air openings.

The generator is equipped with a "pusher" type cooling fan. This type of cooling fan draws air into the generator, then expels the air outward through the engine radiator. If cooling air flow is obstructed, the engine-generator may overheat.

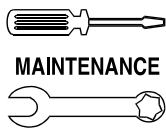

Maintenance

GR-210 Generator Set

■ GROUND FAULT PROTECTION

The generator is equipped with a 120 volt duplex receptacle, and a 120V locking type receptacle. Each of these receptacles incorporates a Ground Fault Circuit Interrupter (GFCI) rated at 20 amps. These devices meet standards with applicable federal, state and local codes.

The GFCI protects against electrical shock that may be caused if the body becomes a path through which electricity travels to reach ground. This could happen if you touch an appliance or cord that is "live." You don't even have to be on the ground, you could be touching plumbing or other material that leads to ground.

When protected by a GFCI, a person will still feel a shock, but the GFCI should cut it off quickly enough so a person in normal health should not have a serious electrical injury (Children can still be affected).



WARNING! THE GFCI WILL NOT PROTECT AGAINST THE FOLLOWING SITUATIONS: (1) LINE-TO-LINE SHOCKS (such as shocks from touching metal in both straight slots of an outlet); (2) CURRENT OVERLOADS OR LINE-TO-LINE SHORT CIRCUITS. THE FUSE OR CIRCUIT BREAKER AT THE DISTRIBUTION PANEL MUST PROVIDE SUCH PROTECTION.

Testing the GFCI: Test the GFCI outlets every month. Follow these instructions:

1. Push the black TEST button. Red RESET button should pop out from inner surface, which should allow no power to reach the outlet. Use a test lamp in each outlet.



CAUTION! If RESET button does not pop out or test lamp remains lit when RESET button does pop out, DO NOT USE ANY OUTLETS ON THE CIRCUIT. CALL A QUALIFIED ELECTRICIAN.

2. If the GFCI tests good, restore power by pressing the RED RESET button. THE RESET BUTTON MUST BE PUSHED FIRMLY AND FULLY INTO PLACE UNTIL IT LOCKS AND REMAINS IN THAT POSITION. IF THE GFCI DOES NOT RESET PROPERLY, DO NOT USE THE OUTLET — CALL A QUALIFIED ELECTRICIAN. Test lamp should go ON.
3. If the GFCI trips by itself at any time during or after installation, reset and perform steps 1 and 2. IF RESET BUTTON DOES NOT POP OUT WHEN TEST BUTTON IS PRESSED, DO NOT USE THE OUTLET. CALL A QUALIFIED ELECTRICIAN.

NOTE:

Each 120 volt receptacle is protected with a 20 amp circuit breaker. The maximum total current from each receptacle is limited to 20 amps (See "Cord Sets - 120 Volt GFCI Duplex Receptacle", and "120 Volt Locking Type Receptacle").

MAINTENANCE

It is the owner's responsibility to perform all safety checks; to verify all required maintenance is performed for safe operation; and to have the equipment checked periodically by an authorized service technician. Normal maintenance service and replacement of parts are the responsibility of the owner/operator and, as such, are not considered defects in workmanship or material under the terms of the warranty.

Individual operating habits and equipment usage contribute to the need for maintenance service. Proper maintenance and care of your generator will help keep the number of problems and overall operating expenses at a minimum. See an authorized Generac Power Systems dealer/distributor or contact the factory for service aids.

■ 100-HOUR BREAK IN

The first 100 hours is the break in period. Correctly breaking in the engine-generator is essential to minimize oil consumption and maximize engine performance. During break in, observe the following rules.

- For the 100 hours of operation, avoid light electrical loads. Load the unit at 50% or more of its capacity during this period. Repeated light loads during break in can cause improper seating of the engine piston rings, resulting in blowby and high oil consumption after prescribed break in period.
- Check engine oil level frequently during break in. It is normal for oil consumption to be higher than normal during this period. The proper break in oil is John Deere's P/N TY22014.
- After the 100-hour break in, complete the tasks recommended under "100-Hour Break In Period".
- If continuous light loads are applied to unit during break in period, run unit for another 100 hour break in period with the recommended engine oil.

■ 100-HOUR BREAK IN PERIOD

After the first 100 hours of operation, contact an authorized service facility for the following maintenance. The generator owner is responsible for all charges.

- Change engine oil and filter.
- Check all fluid levels.
- During break in, don't add oil until level is at the bottom of the crosshatching on dip stick.
- Inspect cooling system hoses for leaks, loose or defective clamps, and for damage or deterioration.
- Check the fuel system for leaks, condition, and tightness of fuel lines.
- Check the engine for proper operation.
- Check generator AC output. Make sure voltage and frequency are correct.

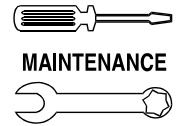

- Check the unit battery for proper electrolyte fluid level, proper state of charge, and condition.
- With engine running, note readings of all gauges and instruments.

RECOMMENDED ENGINE FLUIDS

ENGINE OIL

Use a high quality detergent oil having API classification "For Service CF-4 or CG-4" or oils conforming to CCMC-D5 or CCMC-D4 specifications.

Consider the ambient temperature when selecting the viscosity of lubricating oil for your engine. Use the following chart to determine the oil you use:

AMBIENT TEMPERATURE	OIL RECOMMENDATION
-40° to 30°C (-40° to 86°F)	SAE 0W-30
-30° to 30°C (-22° to 86°F)	SAE 5W-30
-20° to 40°C (-4° to 104°F)	SAE 10W-40
-15° to 50°C (5° to 122°F)	SAE 15W-40
0° to 30°C (32° to 86°F)	SAE 30
10° to 50°C (50° to 122°F)	SAE 40
API Service Certification	CG-4 or CF-4

NOTE:

Multi-viscosity diesel engine oils are preferred. If diesel fuel with sulfur content greater than 0.5% is used, reduce the service interval by 50%.

ENGINE COOLANT

The use of coolant products, as outlined is strongly recommended.

Coolant products to use are silicate ethylene glycol base coolants for heavy-duty diesel engines. Use when mixed with quality water and supplemental coolant additives (SCAs), if they meet the following specifications:

- ASTM D5345 (prediluted coolant)
- ASTM D4985 (coolant concentrate) in a 40% to 60% mixture of concentrate with quality water.

Coolants meeting these specifications require addition of supplemental coolant additives (SCAs), formulated for heavy-duty diesel engines, for protection against corrosion and cylinder liner erosion and pitting.

IMPORTANT:

Never use automotive-type coolants (such as those meeting ASTM D3306 or ASTM D4656). These coolants do not contain the correct additives to protect heavy-duty diesel engines. They often contain a high concentration of silicates and may damage the engine or cooling system.

SUPPLEMENTAL COOLANT ADDITIVES

The recommended coolant additive is John Deere's P/N TY16005 (or compatible) Liquid Coolant Conditioner.

IMPORTANT:

DO NOT over-inhibit antifreeze solutions, as this can cause silicate-dropout. When this happens, a gel-type deposit is created which retards heat transfer and coolant flow causing engine to overheat.

Operating without proper coolant additive will result in increased corrosion, cylinder liner erosion and pitting, and other damage to the engine and cooling system. A simple mixture of ethylene glycol and water WILL NOT give adequate protection.

The use of supplemental coolant additives reduces corrosion, erosion, and pitting. These chemicals reduce the number of vapor bubbles in the coolant and help form a protective film on cylinder liner surfaces. This film acts as a barrier against the harmful effects of collapsing vapor bubbles.

IMPORTANT:

Check inhibitors between drain intervals (every 600 hours or 12 months) of operation. Replenish inhibitors by the addition of a supplemental coolant additive as necessary. DO NOT use soluble oil.

FUEL

Use clean, fresh, No. 2D diesel fuel having a minimum Cetane Number "40" and conforming to ASTM* specifications.

*ASTM — American Society of Testing and Materials

CHECKING FLUID LEVELS

ENGINE OIL

Check engine oil level at least once daily (prior to use) or at least every 8 hours of operation, whichever comes first. The following rules apply:

- When checking oil level, the generator should be sitting on a level surface.
- Always check oil level BEFORE starting the engine, or wait at least 30 minutes after the engine is shut down.
- Avoid mixing different brands or different types of oil.
- The higher pressures and hotter temperatures in a diesel engine require that only Class CF-4 or CG-4 oil be used.

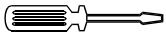

MAINTENANCE

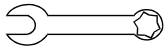

Maintenance

GR-210 Generator Set

- Never operate the engine with oil below the cross-hatching on dipstick.
- Never overfill the engine crankcase above the dipstick crosshatching.
- To check oil level, remove dipstick and wipe dry with a clean cloth. Then, re-insert dipstick into dipstick tube and remove again. Oil should be between the top of the crosshatching and “ADD” marks. Add oil as required.

■ ENGINE COOLANT

Maintaining adequate concentrations of glycol and inhibiting additives in the coolant is critical to protect the engine and cooling system against freezing, corrosion, and cylinder liner erosion and pitting.

Test the coolant solution at 600 hours or 12 month intervals and whenever excessive coolant is lost through leaks or overheating to ensure the necessary protection. If coolant level in radiator or recovery bottle is low, proceed as follows:

- Inspect the radiator cap gasket for wear or damage. Replace cap, if necessary.
- Have the radiator pressure cap tested at an automotive repair facility or at an authorized Generac service facility.
- Check cooling system hoses and radiator for leaks.

NOTE:

When working properly, the coolant recovery system keeps the radiator coolant at the proper level. The radiator cap is equipped with both a pressure relief and a vacuum relief valve. When hot radiator coolant expands, excess coolant opens the pressure relief valve and drains into the coolant recovery bottle. After shutdown, as coolant mixture in the radiator cools, it contracts to form a vacuum. The vacuum relief valve then opens, to draw coolant from the recovery bottle and return it to the radiator. The coolant recovery bottle must be kept filled to the proper level to maintain radiator coolant at the proper level.

■ FUEL

Check fuel quantity at least once daily (every eight hours) and prior to use. If equipped with optional factory trailer package, fill tank when level is between half full and 1/4 full.

IMPORTANT:

NEVER PERMIT THE ENGINE TO RUN OUT OF FUEL. IF ENGINE RUNS OUT OF FUEL OR IF FUEL LEVEL IN TANK DROPS TOO LOW, AIR WILL ENTER FUEL SYSTEM LINES AND CAUSE SERIOUS PROBLEMS, SUCH AS HARD STARTING AND ROUGH, ERRATIC OPERATION. YOU MUST BLEED THE ENGINE FUEL SYSTEM WHEN IT RUNS OUT OF FUEL.

OWNER/OPERATOR PERIODIC MAINTENANCE

Some maintenance tasks may be beyond the capability of the owner/operator and should be done by a competent, qualified service technician. The owner/operator can do the following:

- Check the engine oil level once daily; more often during the 100-hour break in period.
- Inspect entire fuel system once each month. Look for leaks, damage, loose lines, etc.
- Inspect engine drive belts prior to initial use and once each month thereafter. Replace any belt that is worn, cracked weathered, or otherwise damaged. Check and adjust belt tension. Consider tension correct when applying thumb pressure midway between pulleys causes a belt deflection of about 3/8 to 3/4 inch.
- Check battery electrolyte fluid level once each week. Add distilled water, if needed. Also inspect battery posts, cables and terminals for tightness, cleanliness, corrosion. Clean and tighten as required.
- Drain water and sediment from the optional spin-on fuel filter once each week (if so equipped).
- Start and exercise the unit at least once each week. Run the engine for at least 30 minutes during this exercise period.
- Keep the unit clean and as dry as possible. Use a mild detergent and water to clean exterior surfaces. Areas with paint damage should be cleaned, dried and repainted as necessary. An automotive type of paint may be used on the outside of the compartment.
- If unit has the trailer option, check the tire pressure before using and at least once each week thereafter. Keep the tires properly inflated according to tire specifications.

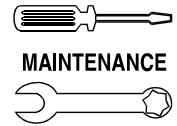

BLEEDING THE FUEL SYSTEM

The fuel system for this engine has a self-bleeding function, so air should not enter the fuel lines unless the engine has been disassembled for any reason. Bleeding air from the fuel system involves manually actuating the fuel lift pump.

PERIODIC MAINTENANCE LIST

The following maintenance tasks should be performed by an authorized service facility at these periodic intervals.

■ DAILY

- Check engine oil and coolant level.
- Check air cleaner dust valve & restriction indicator, replace filter (as required).
- Visual Walk around inspection.
- Inspect AC power cables and cord sets.

■ EVERY 50 HOURS OR 2 WEEKS

- Check fuel filter.

■ EVERY 250 HOURS OR 6 MONTHS

- Check battery state-of-charge and condition, service as necessary.
- Change engine oil and replace filter.**

**Change the oil for the first time after 100 hours maximum of (break-in) operation, then every 250 hours thereafter.

■ EVERY 600 HOURS OR 12 MONTHS

- Clean crankcase vent tube.
- Check air intake hoses, connections & system.
- Replace spin-on fuel filters.
- Check automatic belt tensioner and belt wear.
- Check cooling system.
- Coolant Solution analysis-add SCAs as needed.

■ EVERY 1200 HOURS OR 24 MONTHS

- Adjust droop on generator set engine.
- Pressure test cooling system.
- Flush cooling system.
- Check operation of engine protective devices (low oil pressure, high coolant temperature, overspeed).

■ EVERY 2000 HOURS*

- Check and adjust engine valve clearance.
 - Retorque engine intake manifold bolts.
 - Retorque engine exhaust manifold bolts.
 - Check injection timing.
 - Check/inspect injection nozzles.
 - Check engine compression pressure.
- See Engine Manual for proper information.

ADJUSTMENT OF FUEL INJECTION TIMING

A diesel engine does not have an electrical ignition system like those used on gaseous or gasoline-fueled engines. The diesel fuel is ignited by the heat of compression when the piston moves upward on its compression stroke. The engine firing is timed by precisely timing the injection of fuel into each cylinder at the proper moment. If the unit's injection system appears to be "out of time," have the engine checked and adjusted by an authorized diesel engine service facility. Do not attempt to adjust ignition timing without proper tools, test equipment and general knowledge of the product.

ENGINE SPEED ADJUSTMENT

The engine speed is controlled either with a mechanical governor or electronically.

The mechanical, fixed speed governor is part of the fuel injection pump. The governor was factory set to maintain 62 Hertz (1860 RPM) with no electrical loads applied. Under full rated wattage/amperage capacity, frequency may droop to about 59-60 Hertz.

The electronic governor has a solid-state design for the controller circuit board and actuator. This design results in fast, stable engine response to load changes. The controller board was factory set to maintain the unit's rated speed of 1800 rpm to achieve a frequency of 60 Hertz.

If the engine speed controller on the generator needs adjusting, contact an authorized service facility. They will have the proper equipment and trained personnel to complete all necessary adjustments.

****Contact your nearest Generac/Guardian Authorized Dealer for assistance.**

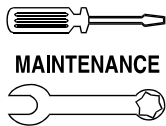

MAINTENANCE

Maintenance

GR-210 Generator Set



WARNING! Do not adjust the engine governed speed without proper equipment and general knowledge. The governed speed was factory set and should require no additional adjustment. Excessively high speeds are dangerous and increase the risk of personal injury or damage to equipment and/or property. Correct AC frequency and voltage are supplied only at the correct governed speed. Some connected electrical devices are extremely sensitive to frequency and voltage, and may be damaged by incorrect frequency and/or voltage. Operation of the unit at excessively low speeds imposes a heavy load on the engine when sufficient engine power is not available and may shorten engine life.

NOTE:

Generally, if AC frequency and voltage are both correspondingly high or low, the engine governor requires adjustment. If AC frequency is correct but voltage is not, the voltage regulator requires adjustment or some other problem exists.

VOLTAGE REGULATOR ADJUSTMENT

The generator's AC voltage regulator has been factory set to allow an operator to select proper voltage via the voltage adjust dial. If the voltage regulator on the generator needs adjusting, contact an authorized service facility. Only qualified service technicians should adjust voltage regulators.

GENERATOR ROTOR BEARING

The generator rotor is attached to the engine drive shaft at one end. The opposite end of the rotor rides in a pre-lubricated and sealed ball bearing that requires no additional lubrication for the life of the bearing.

MAJOR REPAIRS

Proper and regular maintenance of the generator is needed to make sure the generator has a long and trouble-free life. Only a qualified, competent authorized Generac service technician should perform all major generator service, including installation and replacement of factory approved repair parts. Only qualified, competent diesel engine repair facilities should service the engine, using only factory approved parts.

This section or your OWNER'S MANUAL consists of EXPLODED VIEWS pertaining to the generator and its engine, along with PARTS LISTS for the EXPLODED VIEWS. The PARTS LISTS consist of (a) an item number, (b) quantity required, (c) a part number and (d) a description of the part. The ITEM NUMBER relates to an identical number in the EXPLODED VIEW.

HOW TO ORDER PARTS

To order a replacement part, locate the part in the applicable EXPLODED VIEW in this manual. Provide the dealer/distributor with the following information:

- Generator BUILD NUMBER (from the unit data plate).
- Part NUMBER and DESCRIPTION (from the applicable PARTS LIST in this manual).
- The applicable exploded view DRAWING NUMBER.

Electrical Data
GR-210 Generator Set

Wiring Diagram – Control Panel – Drawing No. 0D5632

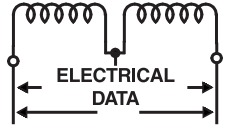

- AM - AMMETER, AC
- BCA - AMMETER BATTERY CHARGER
- CB1 - CIRCUIT BREAKER - FIELD
- D1 - DIODE, 600V/12 AMP
- EC - ENGINE CONTROL
- F1 - FUSE 15 AMP
- G1 - GAUGE, WATER TEMPERATURE
- G2 - GAUGE, OIL PRESSURE
- HM - HOURMETER
- HZ - FREQUENCY METER
- L1 - LAMP, FAULT
- L2 - LAMP, PANEL
- L3 - LAMP, RUN
- PHR - PREHEAT RELAY
- R1 - POTENTIOMETER, VOLTAGE ADJUST
- D2 - RECTIFIER 800V/2A
- R3 - RESISTOR - ENG. ALTERNATOR
- R4 - RESISTOR, FIELD BOOST
- SW2 - SWITCH, START/RUN/STOP
- SW3 - SWITCH, PREHEAT
- SW5 - SWITCH, PHASE SELECTOR
- SW6 - SWITCH, AUTO/OFF/MANUAL
- TB - TERMINAL BLOCK
- VM - VOLT METER, AC
- VR - VOLTAGE REGULATOR

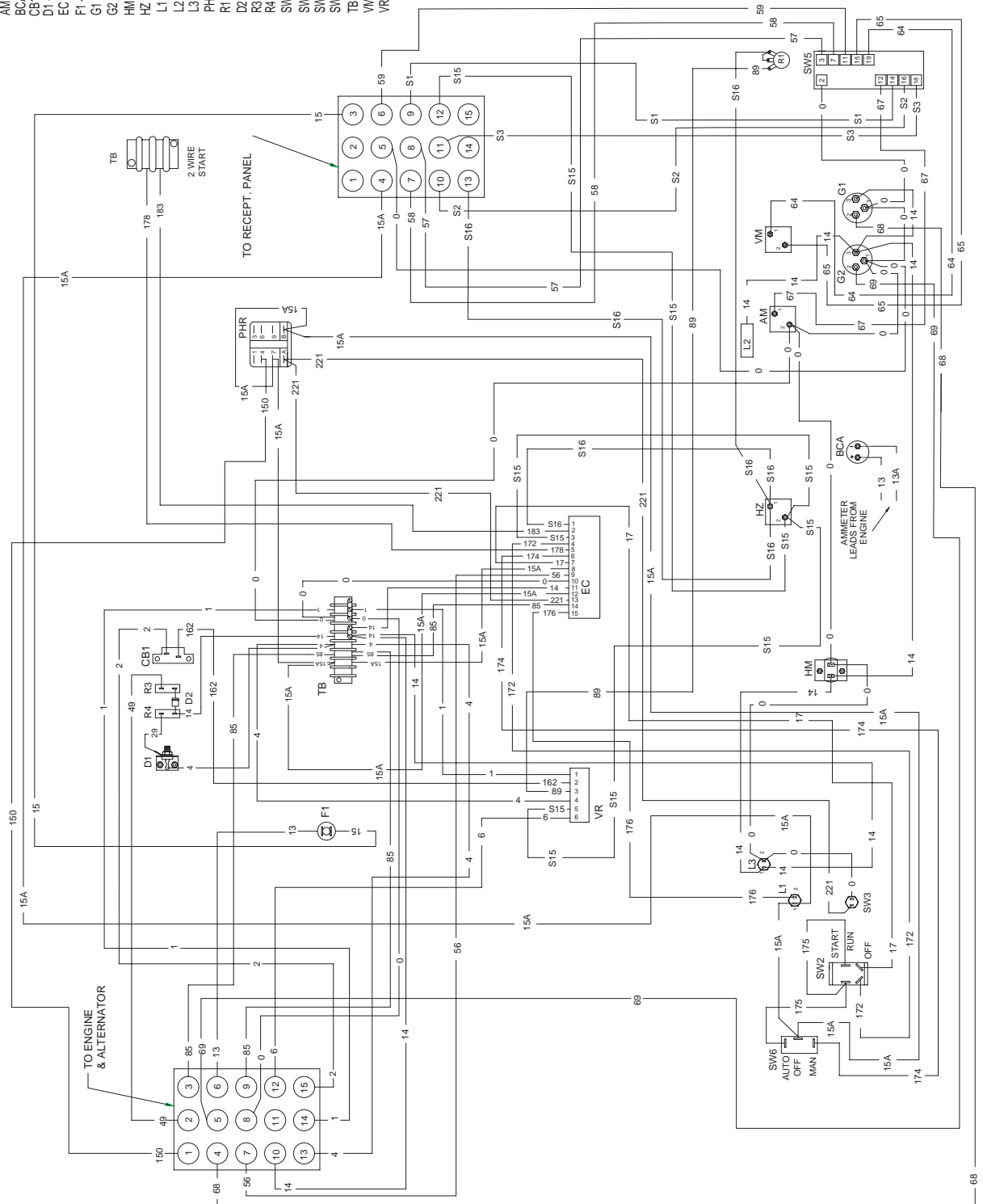

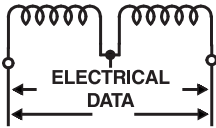

Electrical Data

GR-210 Generator Set

Schematic – Control Panel – Drawing No. 0D5633

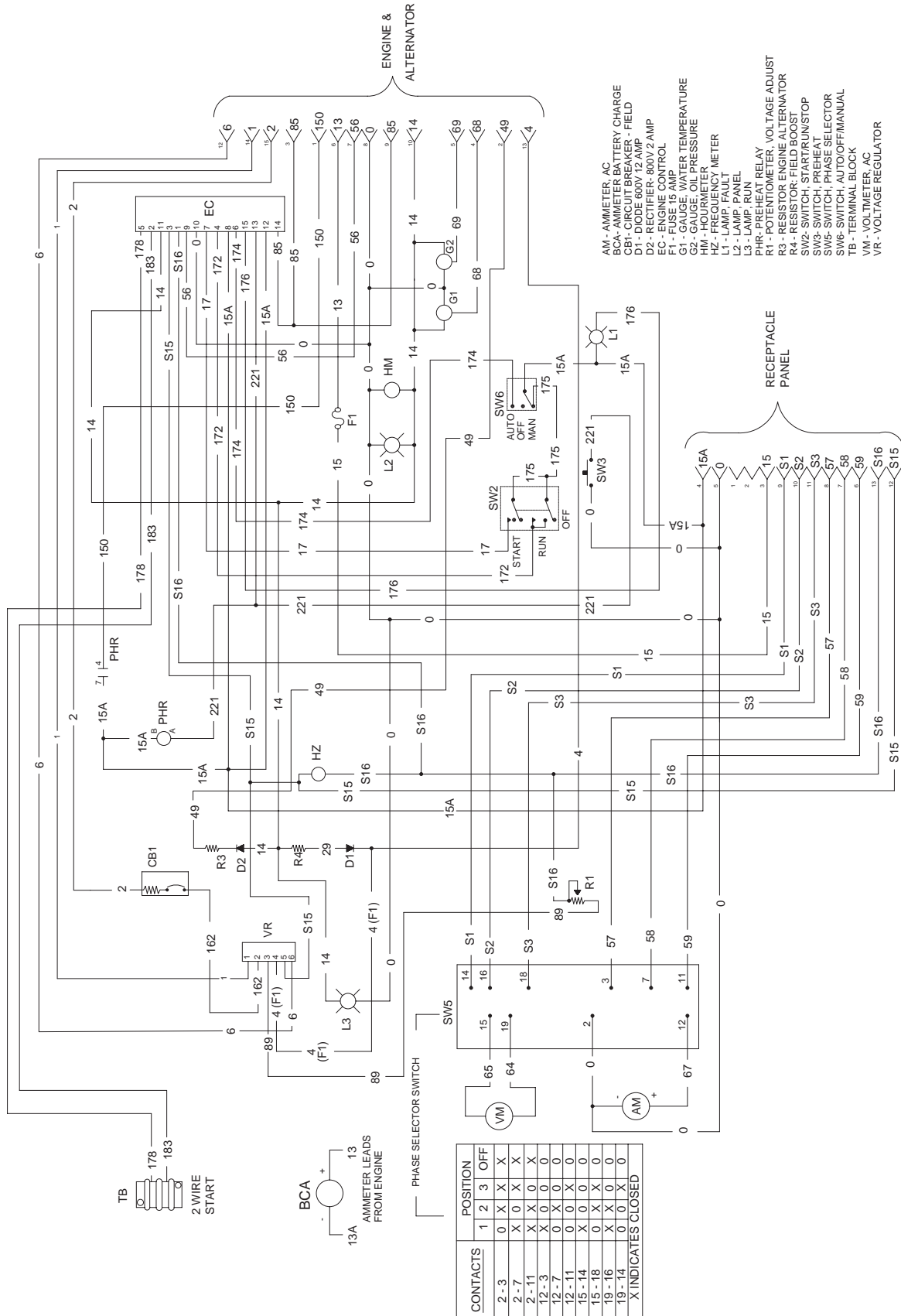

Electrical Data

GR-210 Generator Set

Wiring Diagram – AC Receptacle Panel – Drawing No. 0D6824-A

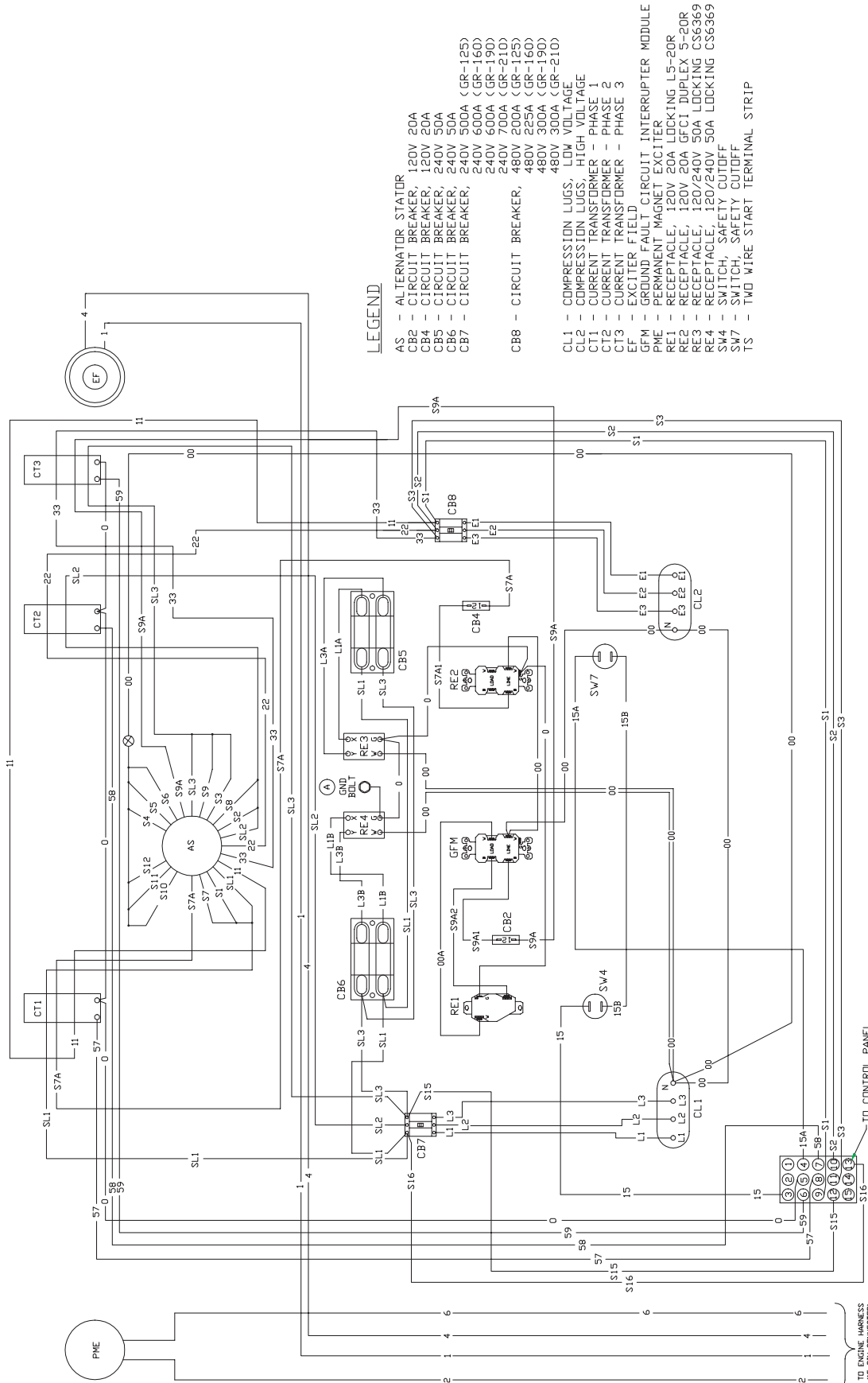
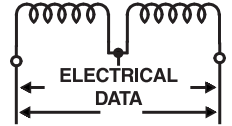

- AS - ALTERNATOR STATOR 120V 20A
- CB2 - CIRCUIT BREAKER, 120V 20A
- CB4 - CIRCUIT BREAKER, 120V 20A
- CB5 - CIRCUIT BREAKER, 240V 50A
- CB6 - CIRCUIT BREAKER, 240V 50A
- CB7 - CIRCUIT BREAKER, 240V 500A (GR-125)
- CB8 - CIRCUIT BREAKER, 240V 500A (GR-160)
- CB8 - CIRCUIT BREAKER, 240V 500A (GR-190)
- CB8 - CIRCUIT BREAKER, 240V 600A (GR-210)
- CB8 - CIRCUIT BREAKER, 480V 200A (GR-125)
- CB8 - CIRCUIT BREAKER, 480V 225A (GR-160)
- CB8 - CIRCUIT BREAKER, 480V 300A (GR-190)
- CB8 - CIRCUIT BREAKER, 480V 300A (GR-210)
- CL1 - COMPRESSION LUGS, LOW VOLTAGE
- CL2 - COMPRESSION LUGS, HIGH VOLTAGE
- CT1 - CURRENT TRANSFORMER - PHASE 1
- CT2 - CURRENT TRANSFORMER - PHASE 2
- CT3 - CURRENT TRANSFORMER - PHASE 3
- EF - EXCITER FIELD
- GFM - GROUND FAULT CIRCUIT INTERRUPTER MODULE
- PME - PERMANENT MAGNET EXCITER
- RE1 - RECEPTACLE, 120V 20A LOCKING L5-20R
- RE2 - RECEPTACLE, 120V 20A GFCI DUPLEX S-20R
- RE3 - RECEPTACLE, 120V/240V 50A LOCKING CS6369
- RE4 - RECEPTACLE, 120V/240V 50A LOCKING CS6369
- SW4 - SWITCH, SAFETY CUTDFF
- SW7 - SWITCH, SAFETY CUTDFF
- TS - TMD WIRE START TERMINAL STRIP

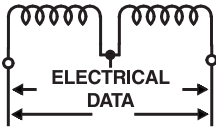

Electrical Data

GR-210 Generator Set

Schematic – AC Receptacle Panel – Drawing No. 0D6825

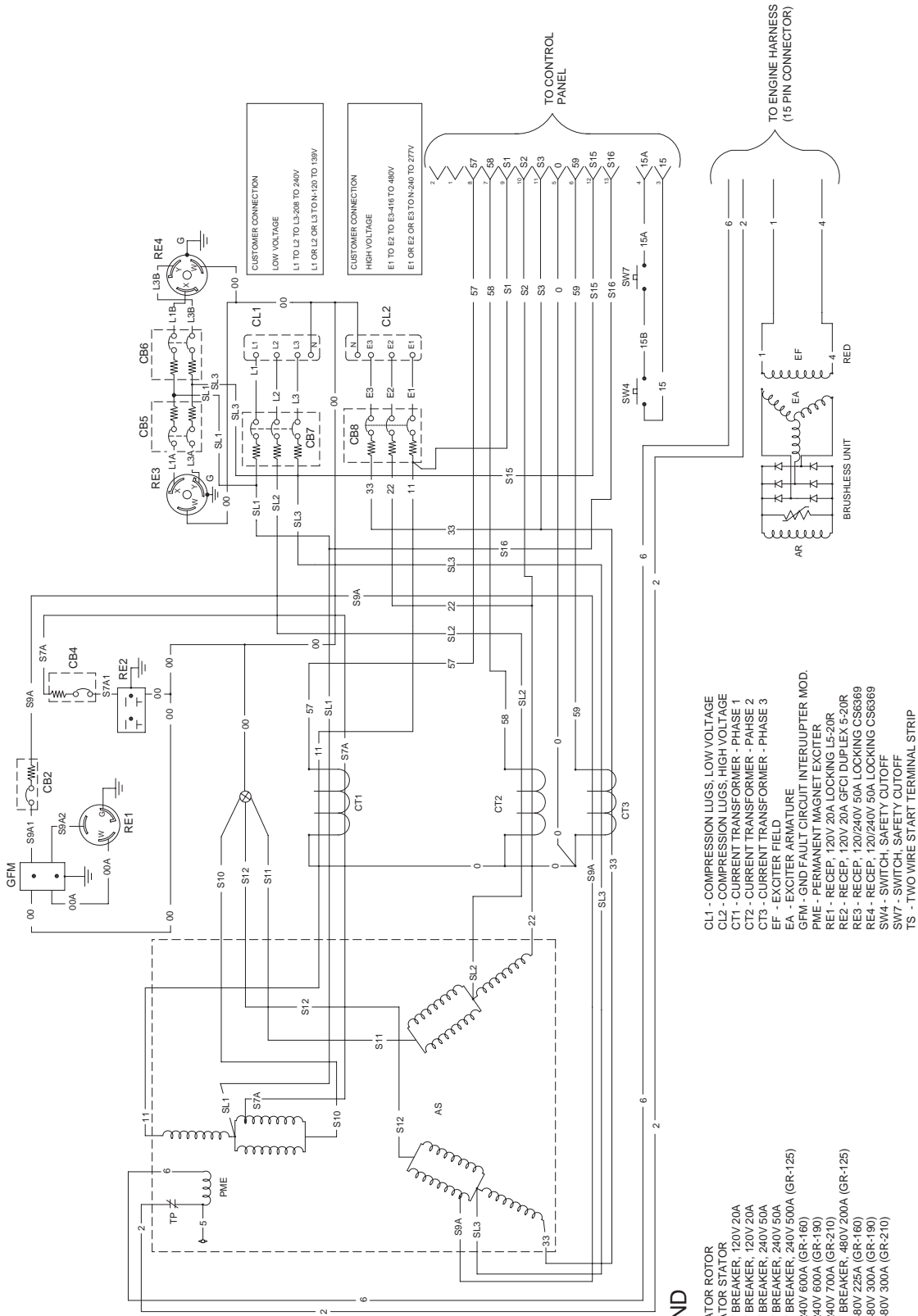

LEGEND

- AR - ALTERNATOR ROTOR
- AS - ALTERNATOR STATOR
- CB2 - CIRCUIT BREAKER, 120V 20A
- CB4 - CIRCUIT BREAKER, 120V 20A
- CB5 - CIRCUIT BREAKER, 240V 50A
- CB6 - CIRCUIT BREAKER, 240V 50A
- CB7 - CIRCUIT BREAKER, 240V 500A (GR-125)
240V 600A (GR-160)
- CB8 - CIRCUIT BREAKER, 480V 200A (GR-125)
240V 600A (GR-190)
240V 700A (GR-210)
- 480V 225A (GR-160)
- 480V 300A (GR-190)
- 480V 300A (GR-210)

- CL1 - COMPRESSION LUGS, LOW VOLTAGE
- CL2 - COMPRESSION LUGS, HIGH VOLTAGE
- CT1 - CURRENT TRANSFORMER - PHASE 1
- CT2 - CURRENT TRANSFORMER - PHASE 2
- CT3 - CURRENT TRANSFORMER - PHASE 3
- EF - EXCITER FIELD
- EA - EXCITER ARMATURE
- GFM - GND FAULT CIRCUIT INTERRUPTER MOD.
- PME - PERMANENT MAGNET EXCITER
- RE1 - RECEPT. 120V 20A LOCKING L5-20R
- RE2 - RECEPT. 120V 20A GFCI DUPLEX 5-20R
- RE3 - RECEPT. 120/240V 50A LOCKING CS6369
- RE4 - RECEPT. 120/240V 50A LOCKING CS6369
- SW4 - SWITCH, SAFETY CUTOFF
- SW7 - SWITCH, SAFETY CUTOFF
- TS - TWO WIRE START TERMINAL STRIP

Electrical Data

GR-210 Generator Set

Wiring Diagram – Diesel Engine – Drawing No. 0A5356

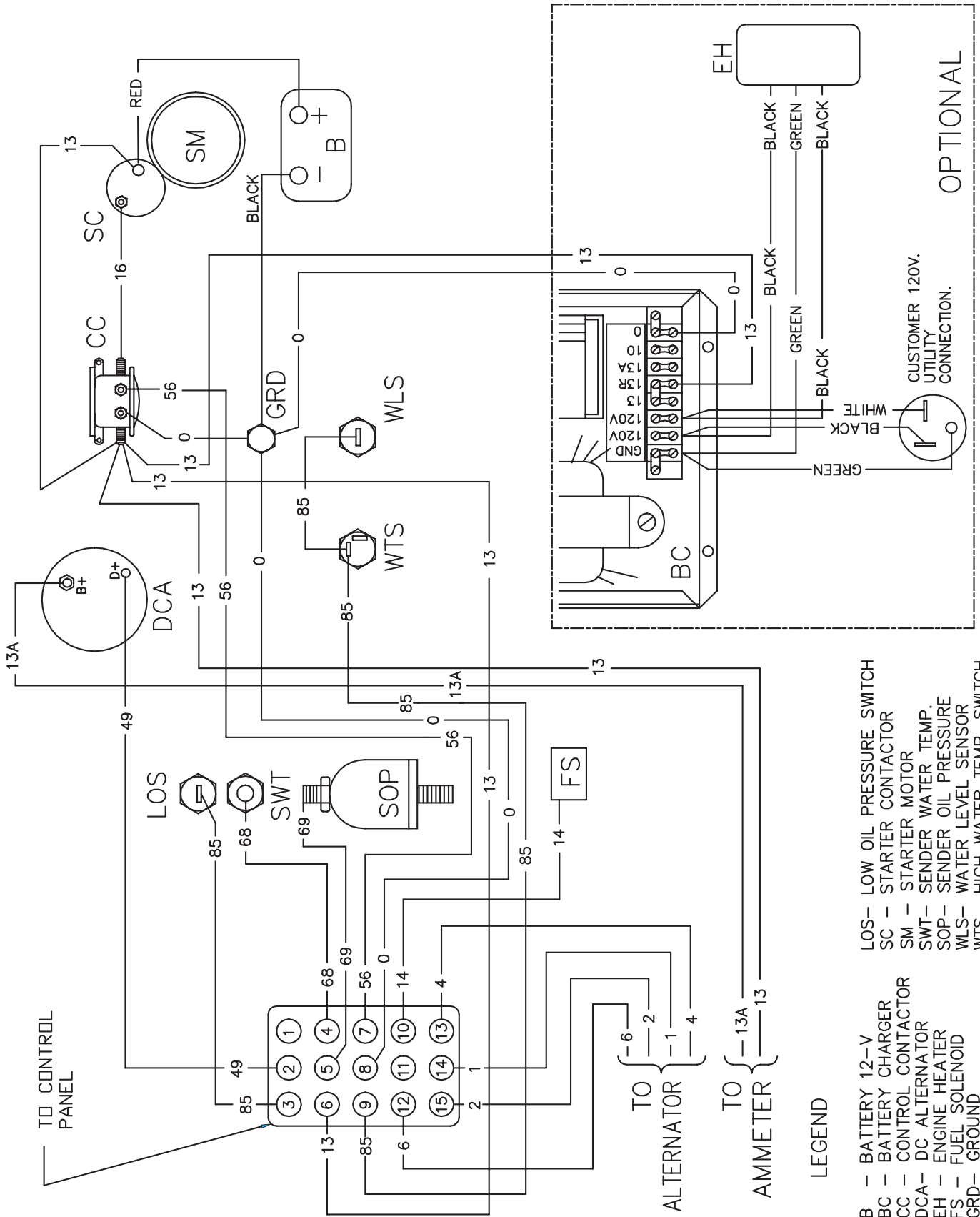
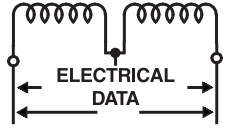

OPTIONAL

CUSTOMER 120V. UTILITY CONNECTION.

- LOS— LOW OIL PRESSURE SWITCH
- SC — STARTER CONTACTOR
- SM — STARTER MOTOR
- SWT— SENDER WATER TEMP.
- SOP— SENDER OIL PRESSURE
- FS — FUEL SOLENOID
- WLS— WATER LEVEL SENSOR
- WTS— HIGH WATER TEMP. SWITCH

- B — BATTERY 12-V
- BC — BATTERY CHARGER
- CC — CONTROL CONTACTOR
- DCA— DC ALTERNATOR
- EH — ENGINE HEATER
- FS — FUEL SOLENOID
- GRD— GROUND

LEGEND

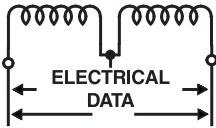

Electrical Data

GR-210 Generator Set

Schematic – Diesel Engine – Drawing No. 0A5357

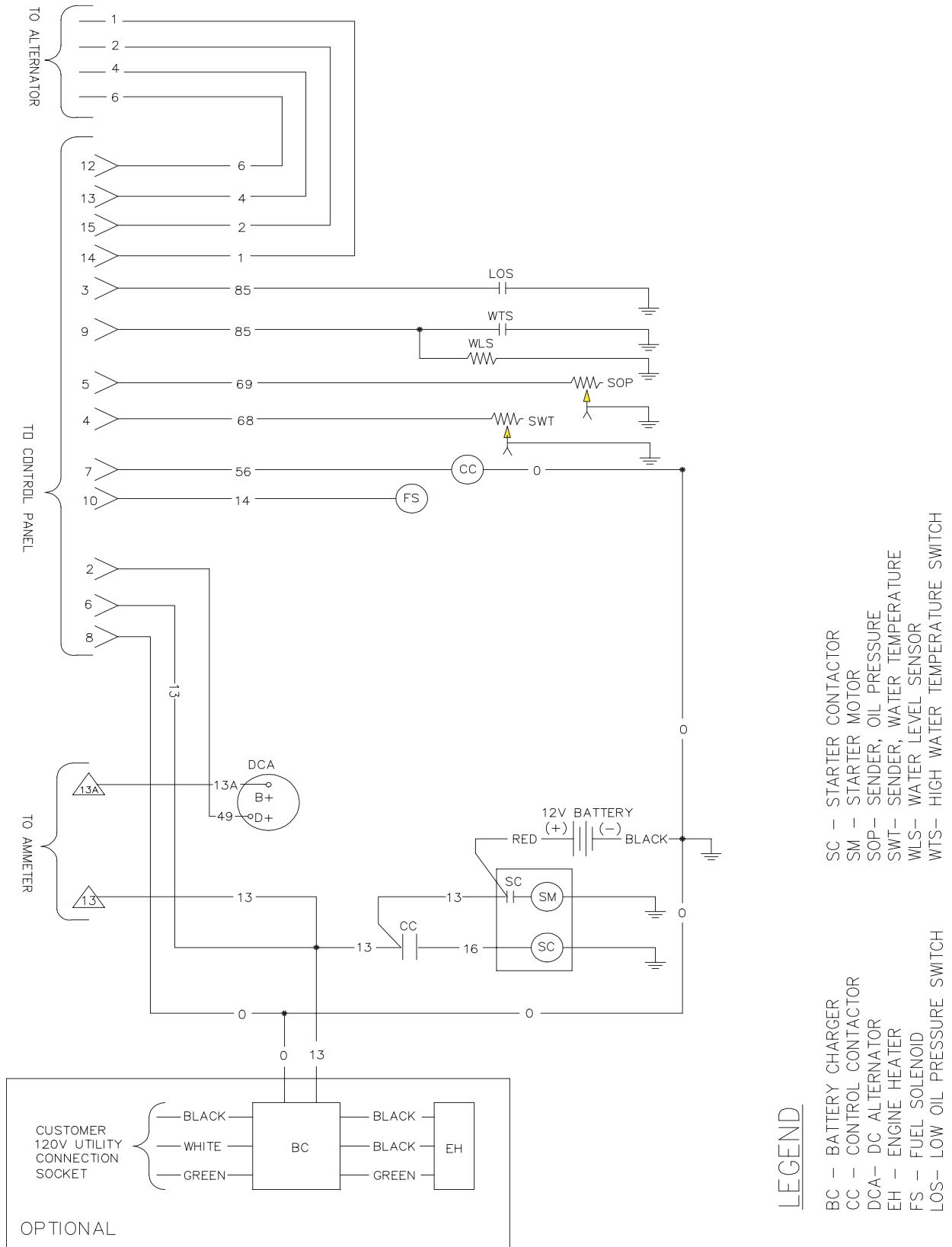

LEGEND

- BC – BATTERY CHARGER
- CC – CONTROL CONTACTOR
- DCA – DC ALTERNATOR
- EH – ENGINE HEATER
- FS – FUEL SOLENOID
- LOS – LOW OIL PRESSURE SWITCH
- SC – STARTER CONTACTOR
- SM – STARTER MOTOR
- SOP – SENDER, OIL PRESSURE
- SWT – SENDER, WATER TEMPERATURE
- WLS – WATER LEVEL SENSOR
- WTS – HIGH WATER TEMPERATURE SWITCH

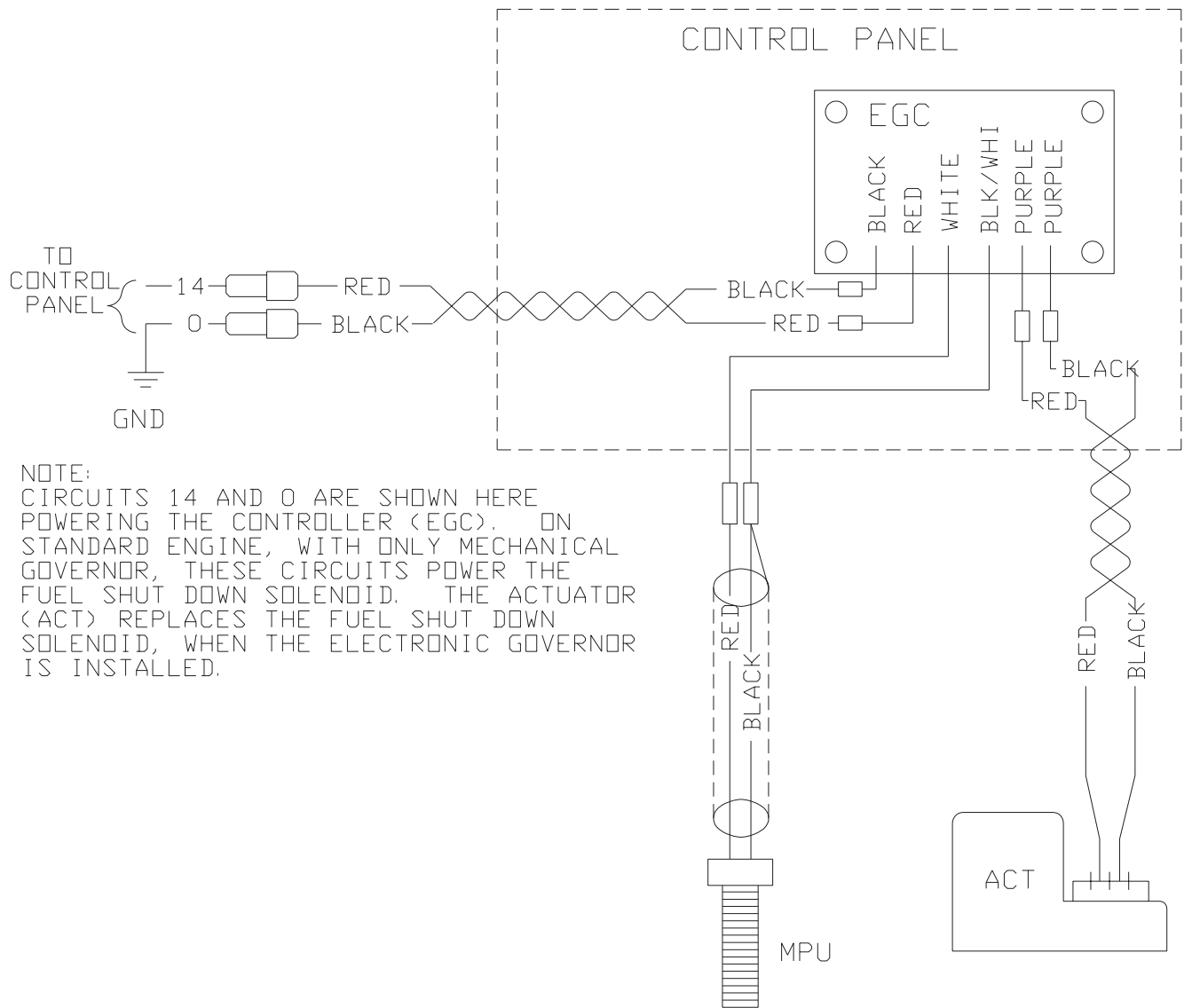
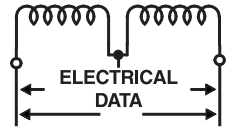

NOTE:
 CIRCUITS 14 AND 0 ARE SHOWN HERE
 POWERING THE CONTROLLER (EGC). ON
 STANDARD ENGINE, WITH ONLY MECHANICAL
 GOVERNOR, THESE CIRCUITS POWER THE
 FUEL SHUT DOWN SOLENOID. THE ACTUATOR
 (ACT) REPLACES THE FUEL SHUT DOWN
 SOLENOID, WHEN THE ELECTRONIC GOVERNOR
 IS INSTALLED.

LEGEND

- ACT - ACTUATOR
- EGC - ELECTRONIC GOVERNOR CONTROLLER
- MPU - MAGNETIC PICK-UP

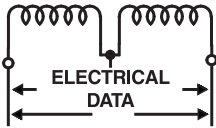

Electrical Data

GR-210 Generator Set

Schematic – Battery Charger – Drawing No. 0D8611

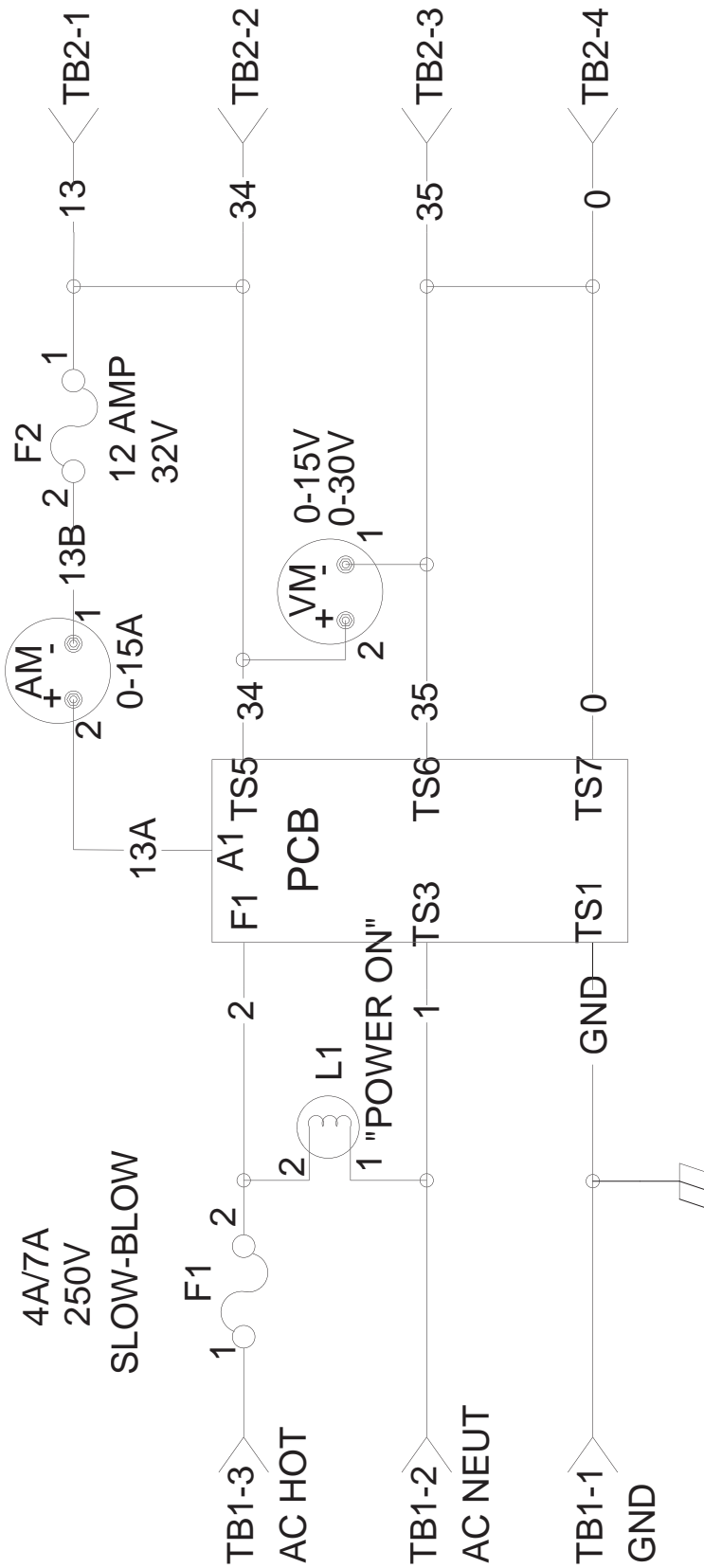

LEGEND

- AM - DC AMMETER, 0-15A
- F1 - FUSE, 250V, 4A (12V) OR 7A (24V)
- F2 - FUSE, 32V, 12A
- GND - GROUND POST
- L1 - LAMP, PANEL
- PCB - CIRCUIT BOARD ASSY, 067666C (12V) OR 067666A (24V)
- TB1 - TERM BOARD, AC INPUT
- TB2 - TERM BOARD, DC OUTPUT
- VM - VOLTMETER, 0-15V(12V) OR 0-30V(24V)

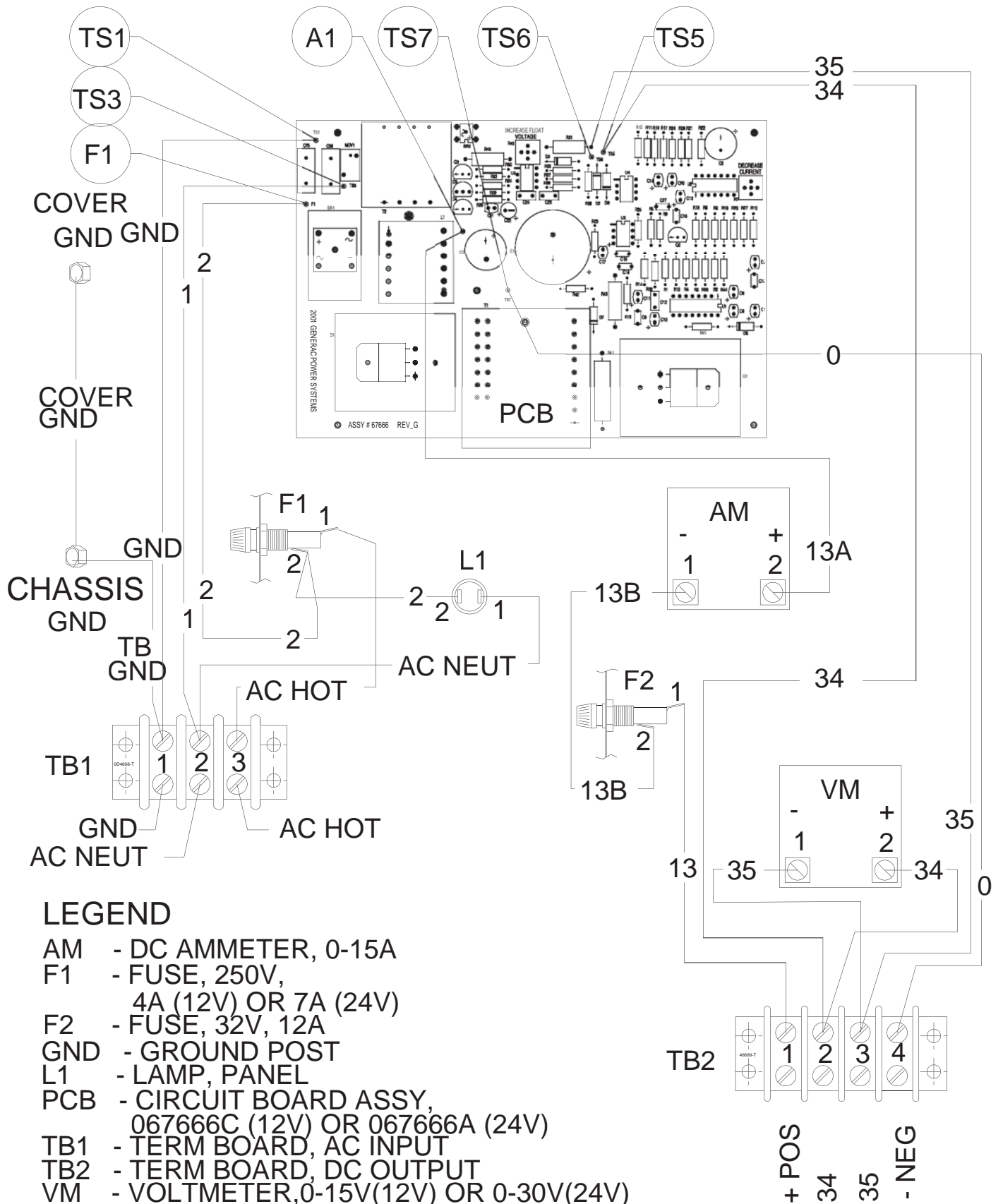
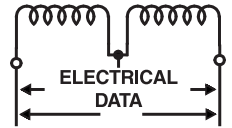

LEGEND

- AM - DC AMMETER, 0-15A
- F1 - FUSE, 250V,
4A (12V) OR 7A (24V)
- F2 - FUSE, 32V, 12A
- GND - GROUND POST
- L1 - LAMP, PANEL
- PCB - CIRCUIT BOARD ASSY,
067666C (12V) OR 067666A (24V)
- TB1 - TERM BOARD, AC INPUT
- TB2 - TERM BOARD, DC OUTPUT
- VM - VOLTMETER, 0-15V(12V) OR 0-30V(24V)

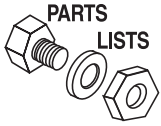

Exploded View and Parts List

GR-210 Generator Set

Air Cleaner – Drawing No. 0A8313-A

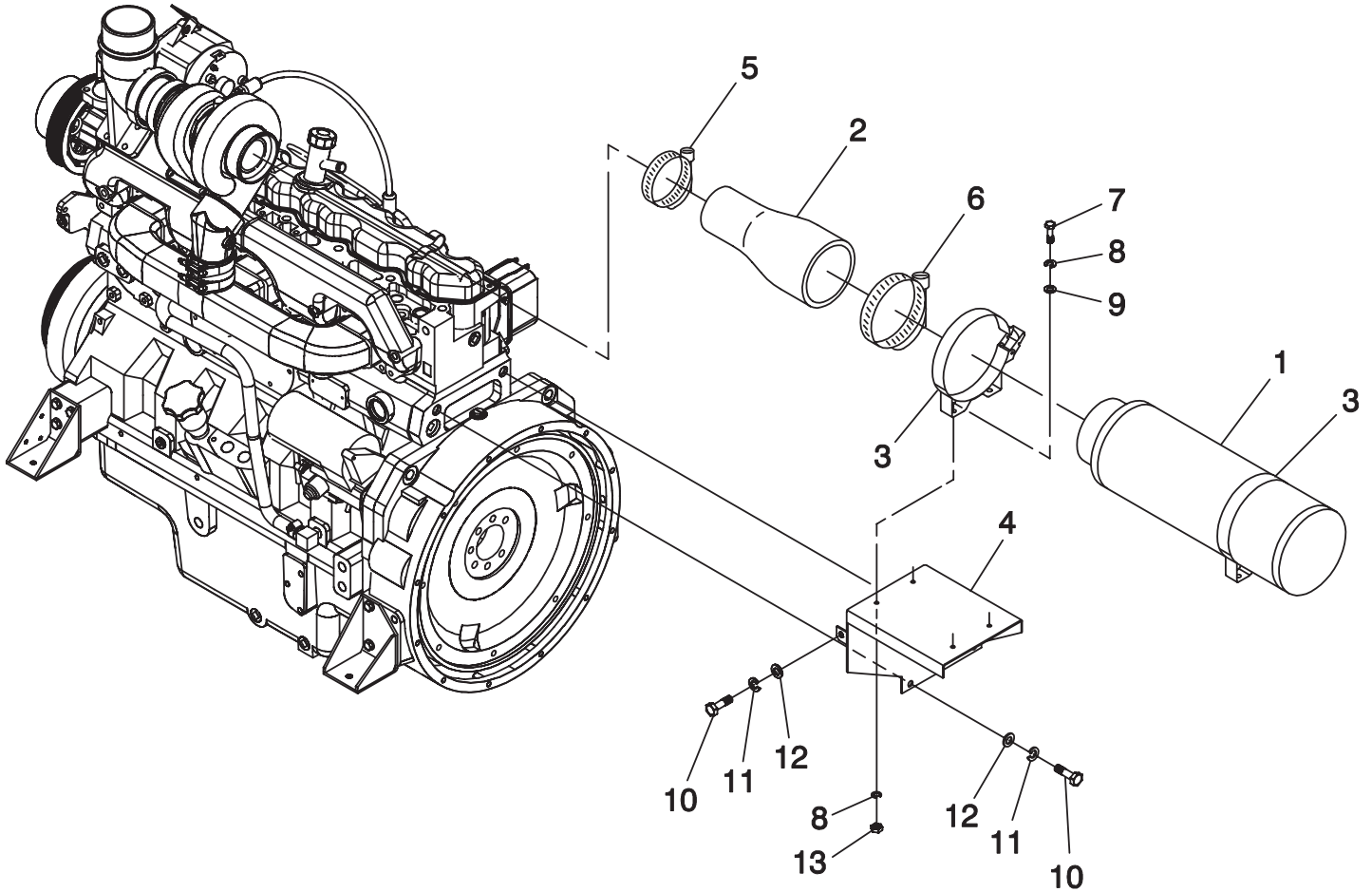

ITEM	PART NO.	QTY.	DESCRIPTION
1	061701	1	AIR CLEANER W/ELEMENT
2	0A6288	1	REDUCER AIR CLEANER
3	061702	2	CLAMP AIR CLEANER
4	0A6289	1	BRACKET AIR CLEANER 8.1L
5	057648	1	CLAMP HOSE #64 3.56 - 4.50
6	058612	1	CLAMP HOSE #88 5.12 - 6.00
7	036833	4	SCREW HHC 3/8-16X1 G8
8	022237	8	WASHER LOCK 3/8
9	022131	4	WASHER FLAT M10-3/8 ZINC
10	023169	3	SCREW HHC 3/4-10 X 2 G5
11	023171	3	WASHER LOCK 3/4
12	045900	3	WASHER FLAT 3/4 ZINC
13	022241	4	NUT HEX 3/8-16 STEEL

Exploded View and Parts List
GR-210 Generator Set
Center Lift – Drawing No. 0A9284-E

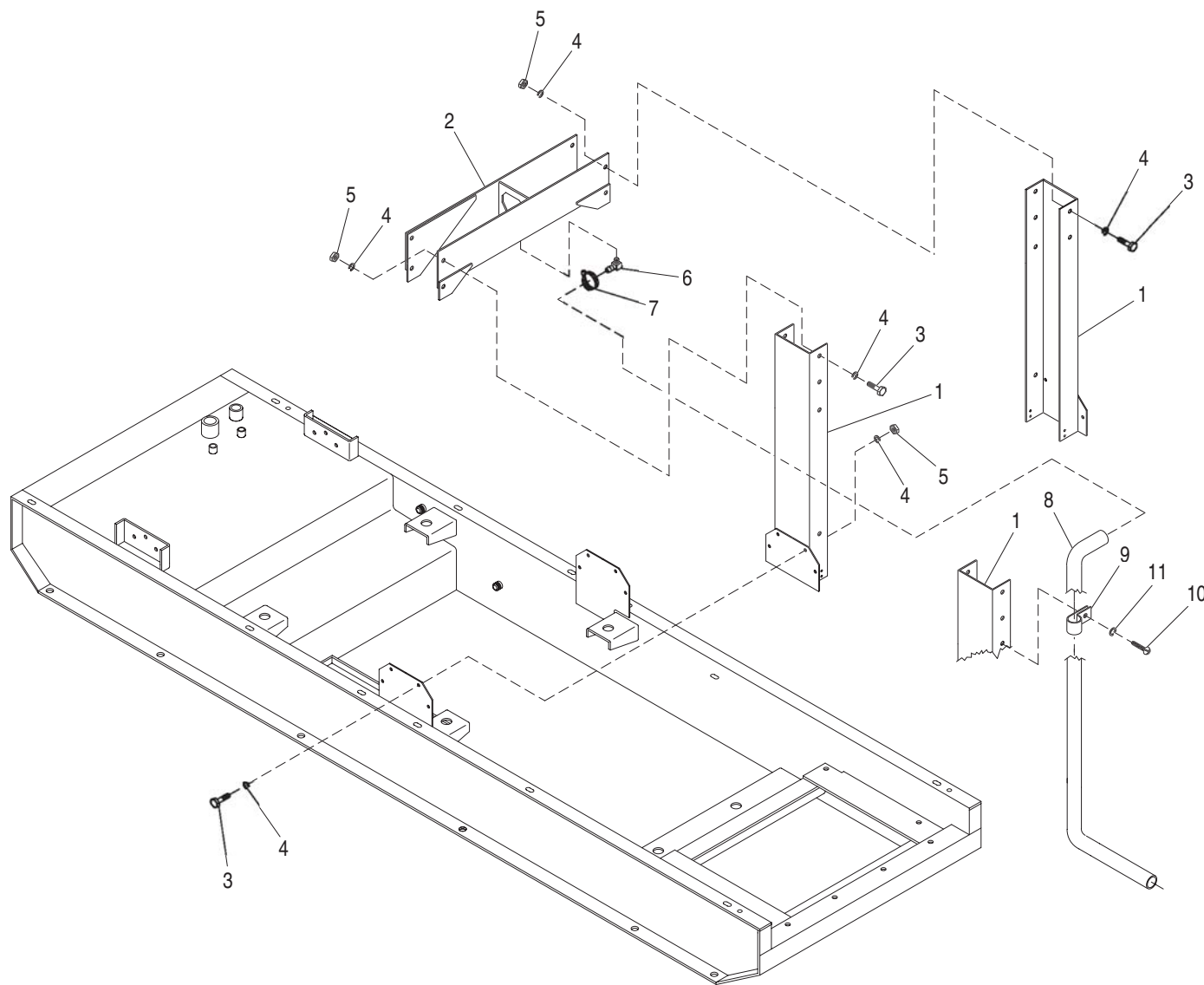
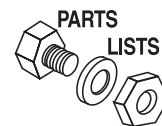

ITEM	PART NO.	QTY.	DESCRIPTION
1	0A9282	2	CENTERLIFT SIDE 8.1
2	0A9283	1	CENTERLIFT TOP WELDMENT
3	059921	16	SCREW HHC M12-1.75 X 40 G10.9
4	022250	32	WASHER FLAT 7/16
5	052860	16	NUT LOCK FL M12-1.75
6	056460	1	BARBED EL 90 1/2 NPT X 5/8
7	057822	1	CLAMP HOSE #8 .53 - 1.00
8	050967	105"	HOSE 5/8 ID RIA 250F
9	055934B	2	CLAMP VINYL 1 X .281 ZINC
10	083512	2	SCREW HHTT M8-1.2 X 16 YC
11	022129	2	WASHER LOCK M8-5/16



Exploded View and Parts List

GR-210 Generator Set

Trailer (OPTIONAL) Model No. 004608-0 – Drawing No. 0D4366-D

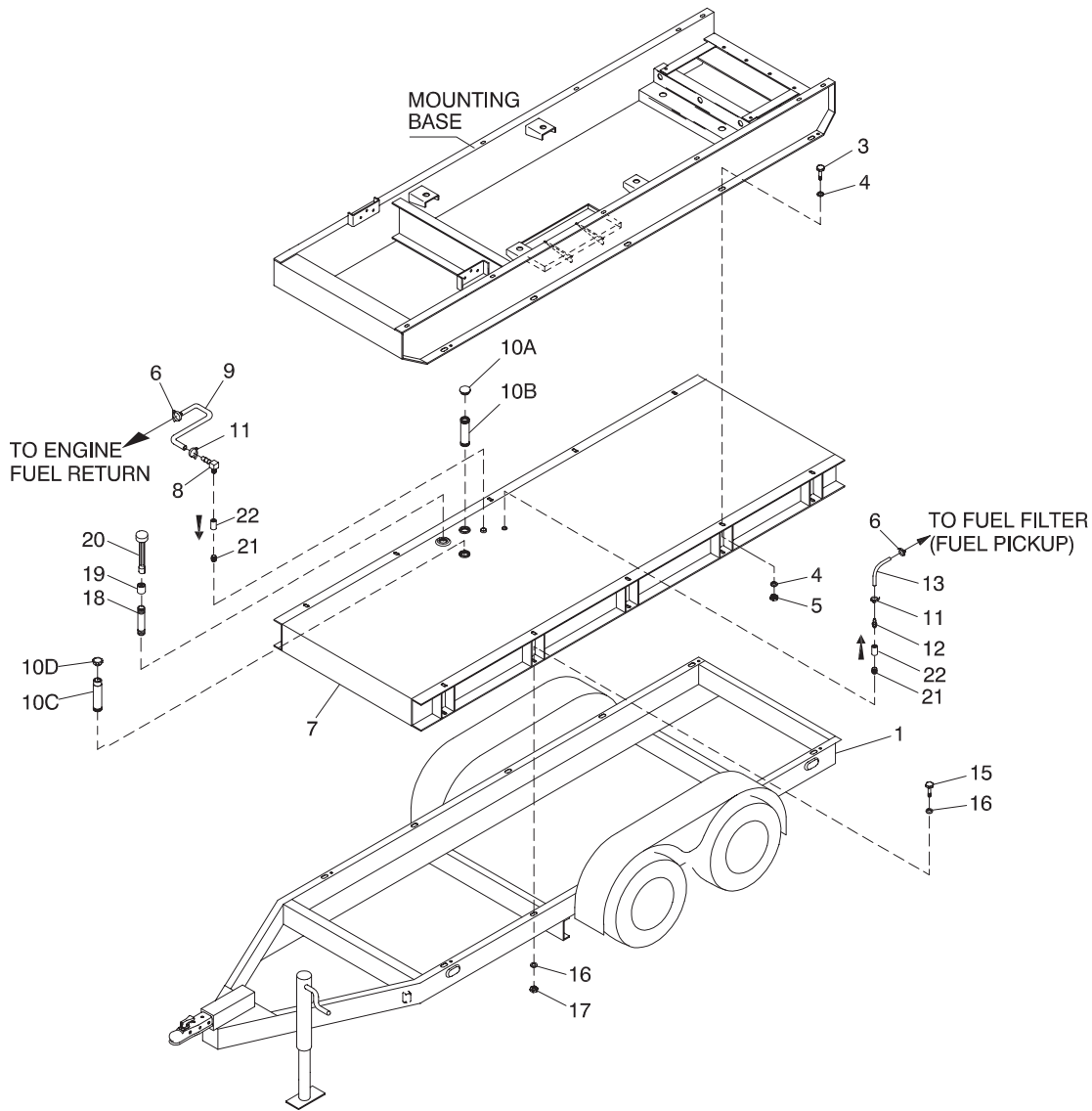

ITEM	PART NO.	QTY.	DESCRIPTION	ITEM	PART NO.	QTY.	DESCRIPTION
1	0D4196	1	TRAILER DUAL AXLE 8.1L JD D/1	11	040173	4	CLAMP HOSE #5.5 .62
2	0D4454	1	KIT GR UNIT MTG HARDWARE ITEMS 3 THRU 6	12	058043	1	BARBED STRAIGHT 1/4 NPT X 5/16
3	035713	10	SCREW HHC 1/2-13 X 1-1/2 G5	13	052221	35"	HOSE RES 5/16 TYP 1 SNGL
4	022304	20	WASHER FLAT 1/2 ZINC	14	0D4455	1	KIT GR TANK MTG HARDWARE ITEMS 15 THRU 17
5	073320	10	NUT LOCK HEX INDENT 1/2-13 G5	15	035713	10	SCREW HHC 1/2-13 X 1-1/2 G5
6	040173	2	CLAMP HOSE #5.5 .62 - .62	16	022304	20	WASHER FLAT 1/2 ZINC
7	0D4416	1	BASE TANK GR 8.1L 264 GAL.	17	073320	10	NUT LOCK HEX INDENT 1/2-13 G5
8	062007	1	ELBOW BARBED 90 1/4 NPT X 1/4	18	091042	1	NIPPLE 1-1/2 NPT X 5.68
9	074995	36"	HOSE 1/4 ID PETROLEUM	19	067729	1	COUPLING FULL 1.5-11.5 TAPERED
10	0D2740	1	FUEL FILL EXTENSION KIT-19"	20	0D6318	1	GAUGE FUEL
10A	0A1492	1	CAP FUEL FILL	21	026942	2	NIPPLE CLOSE 1/4NPT X .875
10B	0D2670C	1	FUEL FILL NECK 490MM	22*	062828	2	CHK VALVE 0.25 NPT
10C	0D2736	1	NIPPLE PIPE 2 NPT X 18" BLK IRN				
10D	021178	1	VENT OEM 2"				

*ENSURE ARROW POINTS IN DIRECTION OF FUEL FLOW.

Exploded View and Parts List

GR-210 Generator Set

Muffler – Drawing No. 0A9309-B

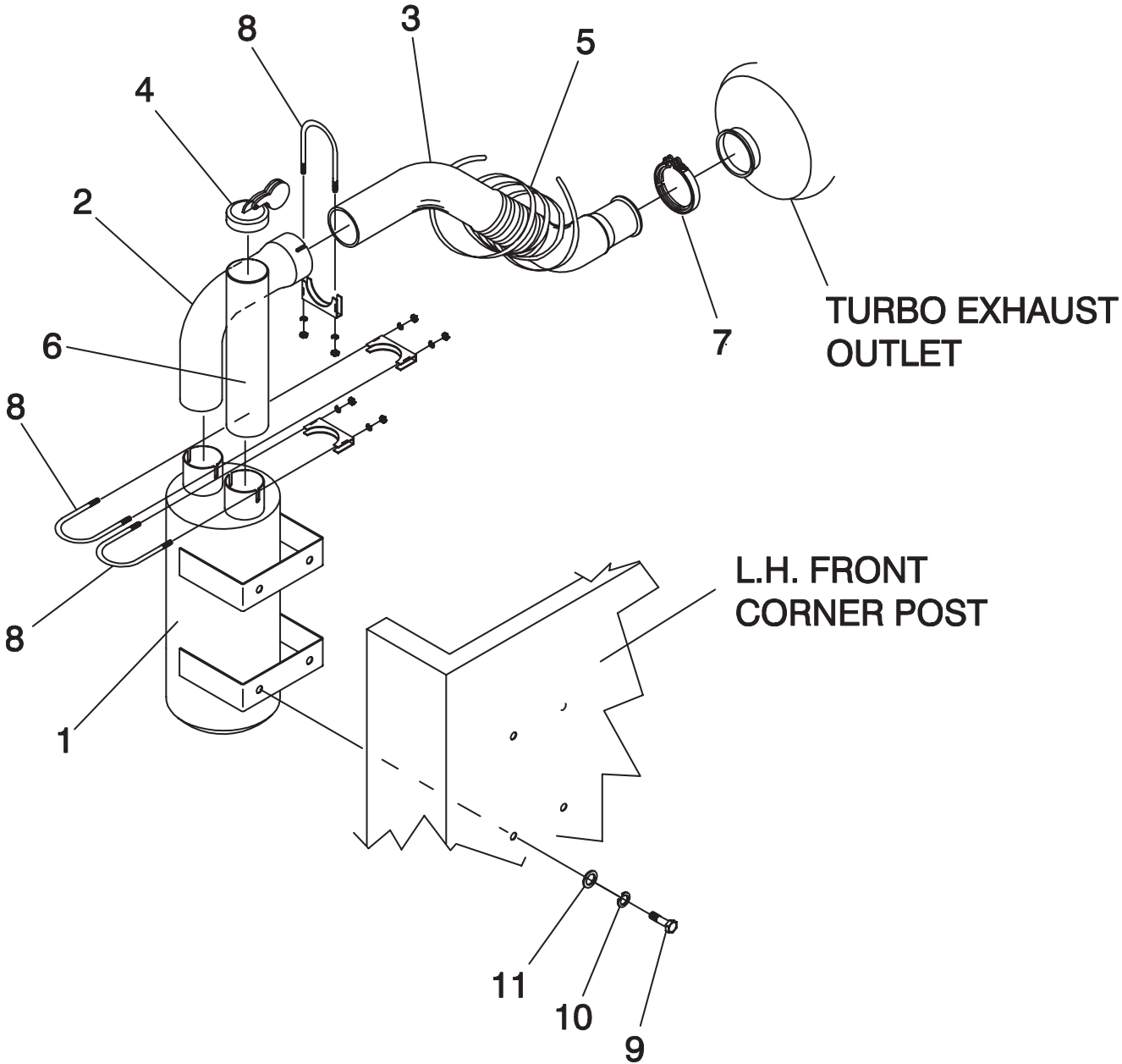

ITEM	PART NO.	QTY.	DESCRIPTION
1	0A8189	1	WELDMENT MUFFLER 8.1L
2	0A7736	1	ELBOW MUFFLER 8.1L
3	0A9208	1	EXHAUST FLEX 8.1L
4	083218	1	CAP RAIN 4.00/4.19
5	082361	10.5'	INSULATION EXHAUST
6	0A9307	1	PIPE EXHAUST 4" OD X 14" LG
7	098458	1	CLAMP V-BAND EXHAUST
8	087113	3	BOLT U 3/8-16 X 4.5
9	087172	4	SCREW HHC 1/2-13 X 1-1/2 SS
10	083215	4	WASHER LOCK 1/2 SS
11	087171	4	WASHER FLAT 1/2 SS

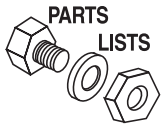

Exploded View and Parts List

GR-210 Generator Set

Mounting Base – Drawing No. 0D4362

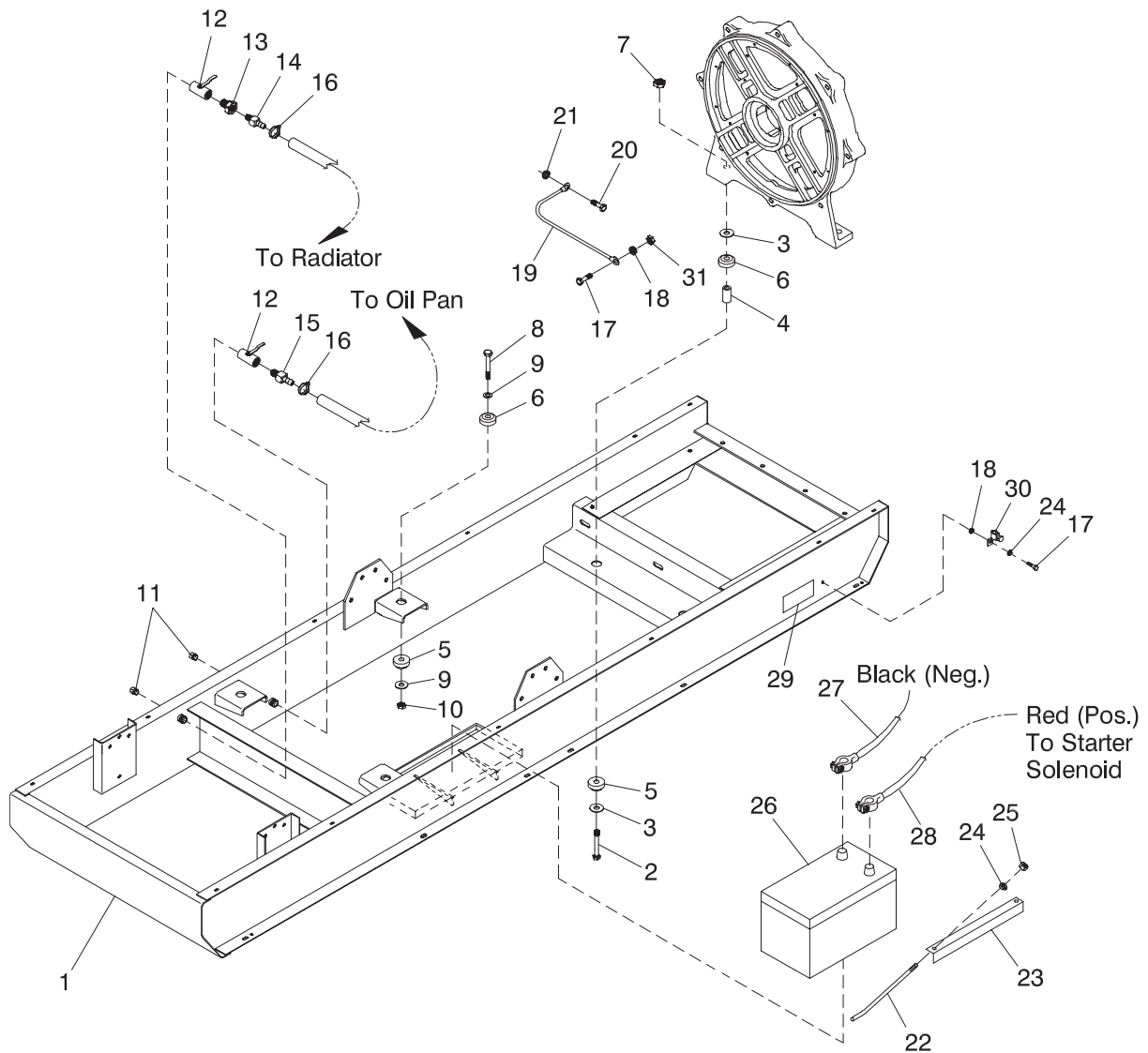

ITEM	PART NO.	QTY.	DESCRIPTION	ITEM	PART NO.	QTY.	DESCRIPTION
1	0D4342	1	MOUNTING BASE 8.1L J.D. D/1	17	033212	2	SCREW HHC 5/16-18 X 1-1/4 G5
2	055597	2	SCREW HHC M12-1.75 X 85 G8.8	18	027482	2	WASHER SHAKEPROOF EXT 5/16 STL
3	052259	4	WASHER FLAT M12	19	0536210147	1	GROUND WIRE #4 10.0"
4	052257	4	SPACER .49 X .62 X 1.87 PWDR/ZNC	20	051756	1	SCREW HHC M10-1.5 X 20 G8.8
5	059676	6	MOUNT LOWER VIBRATION	21	025507	2	WASHER SHAKEPROOF EXT 7/16 STL
6	059675	6	MOUNT UPPER VIBRATION	22	059567	3	BOLT BATTERY HOLD DOWN
7	052860	2	NUT LOCKING M12-1.75	23	059568	1	BAR BATTERY HOLD DOWN
8	059983	4	SCREW HHC M14-2.0 X 110 G8.8	24	022145	14	WASHER FLAT 5/16 ZINC
9	022132	8	WASHER FLAT 9/16 ZINC	25	027028	2	NUT LOCK HEX 5/16-18 NYL INS
10	060079	4	NUT LOCK HEX M14-2.0 NYL INS	26	061915	1	BATTERY 12V 135-AH 4DLT
11	036532	2	CAP PIPE 1/2 NPT	27	038805Y	1	CABLE BATT BLK #1 X 16.00
12	078944	2	VALVE BALL	28	03880400AE	1	CABLE BATT RED #1 X 18.00
13	030418	1	BUSHING REDUCER 1/2 TO 3/8	29	094988	1	DECAL GROUNDING
14	055596	1	BARB STRAIGHT 3/8 NPT X 3/8	30	061383	1	LUG SLDLSS 3/0-#4 X 13/32 CU
15	044118	1	BARB STRAIGHT 1/2 NPT X 5/8	31	022259	1	NUT HEX 5/16-18 STEEL
16	057822	1	CLAMP HOSE #8 .53 - 1.00				

Exploded View and Parts List

GR-210 Generator Set

Engine Common Parts – Drawing No. 0A8312-A

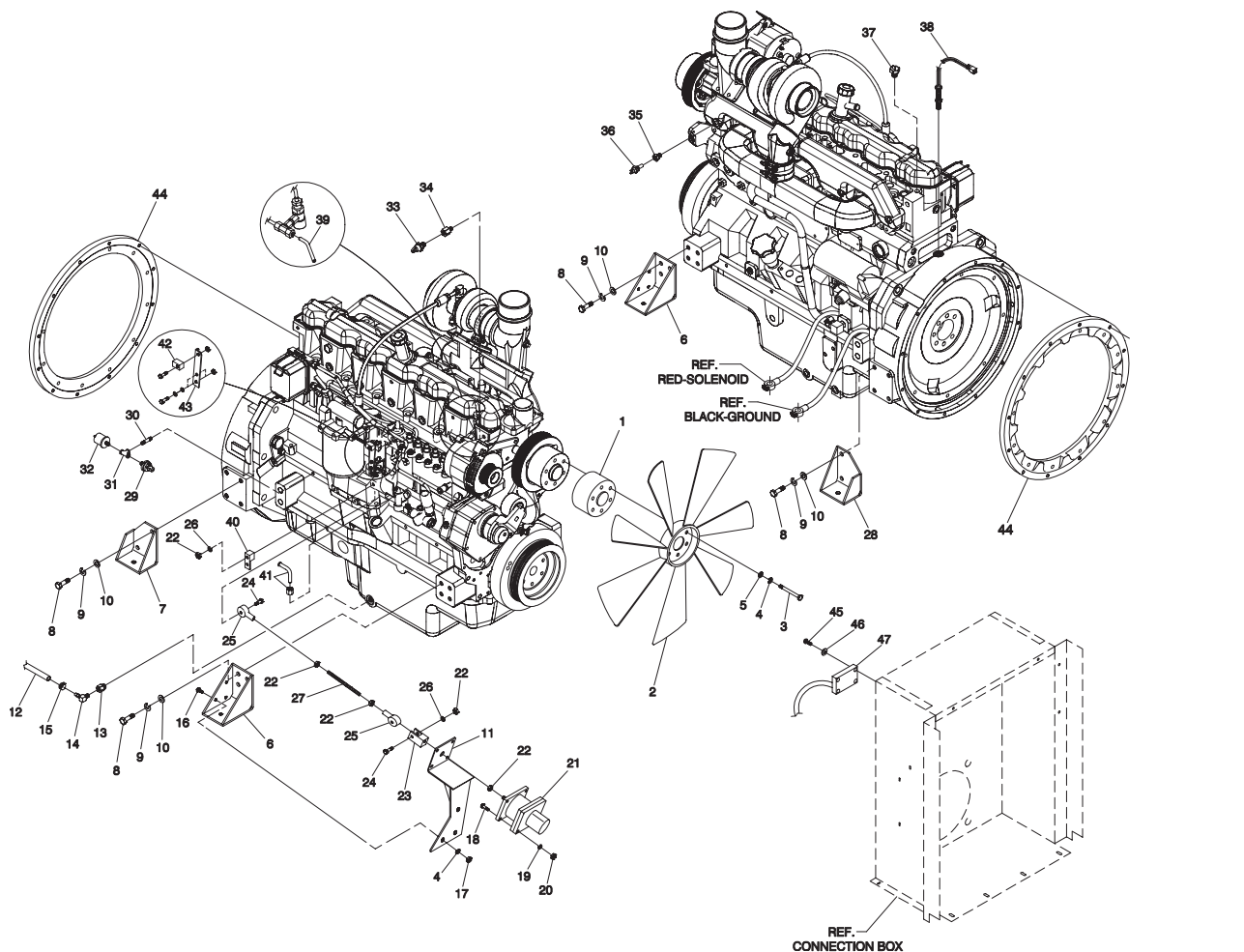
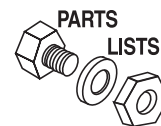

ITEM	PART NO.	QTY.	DESCRIPTION
1	0C1058	1	SPACER FAN 8.1L
2	0C1507	1	FAN 28" 8.1L JD
3	031678	6	SCREW HHC 3/8-16 X 3-3/4 G5
4	022237	9	WASHER LOCK 3/8
5	022131	6	WASHER FLAT 3/8-M10 ZINC
6	0C1533	2	MOUNT ENGINE FRONT RH WLDM
7	0A6390A	1	MOUNT ENGINE REAR RH 8.1
8	0A7934	14	SCREW HHC 5/8-11X1.75 G8
9	022246	14	WASHER LOCK 5/8
10	022247	14	WASHER FLAT 5/8 ZINC
11	0A7930	1	ASSEMBLY GOVERNOR BRACKET
12	065386	16.5"	HOSE 5/8 ID SAE100R6
13	0A4707H	1	ADAPT 1/2 NPT X M22 X 1.5
14	056460	1	BARB ELBOW 1/2 NPT X 5/8
15	057823	1	CLAMP HOSE #10 .56 - 1.06
16	036833	3	SCREW HHC 3/8-16 X 1 G8
17	022241	3	NUT HEX 3/8-16 STEEL
18	042568	4	SCREW HHC M6-1.0 X 20 G8.8
19	022097	4	WASHER LOCK M6-1/4
20	049813	4	NUT HEX M6 -1.0 G8 YEL CHR
21	088920	1	ACTUATOR LINEAR
22	022158	9	NUT HEX #10-32 STEEL
23	080534	1	CLEVIS #10-32
24	022859	2	SCREW RHM #10-32 X 3/4

ITEM	PART NO.	QTY.	DESCRIPTION
25	090185	2	ROD END #10-32 R/H
26	022152	2	WASHER LOCK #10
27	020495	1	STUD #10-32 X 5.0 F THR
28	0A6390B	1	MOUNT ENGINE REAR LH 8.1
29	0A8584	1	SWITCH OIL PRESSURE
30	035483	1	NIPPLE PIPE 1/8 NPT X 1-1/2
31	035430	1	TEE PIPE 1/8 NPT
32	053666	1	SENDER OIL PRESSURE
33	057522	1	SENSOR COOLANT LEVEL
34	030418	1	BUSHING REDUCER 1/2 TO 3/8
35	065809	1	ADAPTER WATER TEMP SENDER
36	053667	1	SENDER, WATER TEMP
37	035606	1	SENSOR HI COOLANT SHUTDOWN
38	0C9405	1	ASSEMBLY MAGNETIC PICKUP 8.1L JD
39	0A4854	1	TUBE FUEL RET 4.5L
40	079945	1	ARM THROTTLE
41	0C1827	1	TUBE FUEL RETURN
42	0C1523	1	BRACKET POSITIONING MECH GOV
43	0A7901	1	BRACKET MECHANICAL GOVERNOR
44	0A5431	1	PLATE ADAPTOR
45	033138	4	SCREW HHM #10-32 X 5/8
46	023897	4	WASHER FLAT #10 ZINC
47	067709	1	CONTROLLER 12V



Exploded View and Parts List

GR-210 Generator Set

Compartment – Drawing No. 0D4452-C

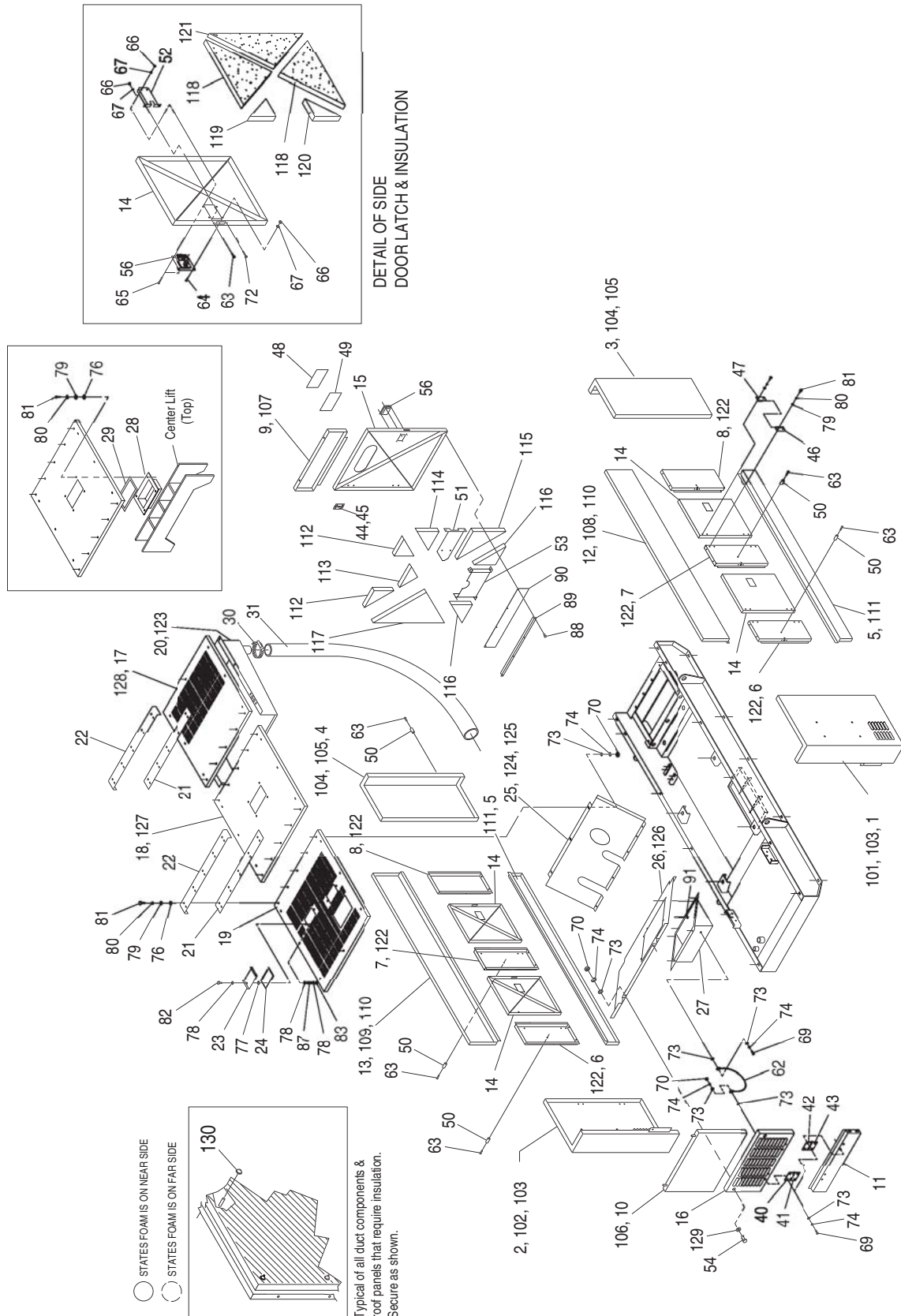

○ STATES FOAM IS ON NEAR SIDE
 ○ STATES FOAM IS ON FAR SIDE

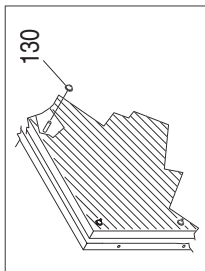

Typical of all duct components & roof panels that require insulation. Secure as shown.

Exploded View and Parts List

GR-210 Generator Set

Compartment – Drawing No. OD4452-C

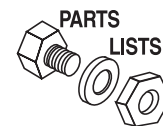

ITEM	PART NO.	QTY.	DESCRIPTION	ITEM	PART NO.	QTY.	DESCRIPTION
1	0D4444	1	CORNER POST LH FRONT GR 8.1L D/1	69	0A3359	10	SCREW BHSC M6-1.0 X 16 SS
2	0D4445	1	CORNER POST RH FRONT GR 8.1L D/1	70	071946	6	NUT HEX M6-1.0
3	0A6302	1	CORNER POST REAR LH	71	089906	14	SCREW PFHM 1/4-20 X 3/4 SS
4	0A7983	1	CORNER POST REAR RH	72	089901	15	SCREW PFHM 1/4-20 X 1-1/2 SS
5	0D4451	2	LOWER BRACE GR 8.1L D/1	73	084929	43	WASHER FLAT 1/4 SS
6	0D4446	2	SIDE POST FRONT GR 8.1L D/1	74	083896	40	WASHER LOCK 1/4-M6 SS
7	0D4447	2	SIDE POST MIDDLE GR 8.1L D/1	75	085889	29	NUT HEX 1/4-20 SSTL
8	0D4448	2	SIDE POST REAR GR 8.1L D/1	76	095395	48	WASHER NYLON .315
9	0A8009	1	COMPT BRACE REAR TOP	77	049850	2	WASHER NYLON .31
10	0A8004	1	BRACE FRONT TOP	78	022145	6	WASHER FLAT 5/16 ZINC
11	0A7995	1	BRACE FRONT BOTTOM	79	090977	152	WASHER FLAT .375 ID X .875 OD
12	0D4449	1	UPPER BRACE LH GR 8.1L D/1	80	070006	152	WASHER LOCK M8 SS
13	0D4450	1	UPPER BRACE RH GR 8.1L D/1	81	070013	152	SCREW HHC 5/16-18 X 3/4 SS VIB
14	092141	4	DOOR FRONT	82	070014	2	SCREW HHC 5/16-18 X 1 3/4 SS
15	091111	1	DOOR RECEPTACLE PANEL	83	025244	2	NUT HEX JAM 5/16-18 STEEL
16	0D4453	1	PANEL FRONT ACCESS GR 8.1L D/1	87	056315	2	SPRING COMPARTMENT .35 ID X 1.0
17	0A6309	1	COMPT ROOF REAR	88	0A7215	4	SCREW SWAGE 1/4-20 X 5/8 N WA JS500
18	0A6307	1	COMPT ROOF MIDDLE	89	090355	1	BRACKET SPLASH GUARD
19	0A6306	1	COMPT ROOF FRONT	90	090354	1	GUARD SPLASH
20	0A8292	1	DUCT REAR		0D4578	1	KIT AI GR 8.1L (EAGLE) D/1
21	0A8395	2	COMPT ROOF RUBBR 8.1	91	087233	8	RIVET POP 3/16 X 1/4
22	0A8037	2	COMPT ROOF SEAL CHANL	101	0A6313000A	1	INSULATION CORNER POST FRONT #1 LH
23	056313	2	COVER ACCESS	102	0A6313000B	1	INSULTION CORNER POST FRONT #1 RH
24	056326	2	TRIM VINYL BLACK 1/8 GP (18" LONG)	103	0A6313000C	2	INSULATION CORNER POST FRONT #2
25	0A8078	1	RADIATOR BLOCK OFF PLATE	104	0A6313000D	2	INSULATION CORNER POST REAR #1
26	0A6628	1	BAFFLE LOWER FRONT	105	0A6313000E	2	INSULATION CORNER POST REAR #2
27	0A8042	1	TRAY MUFFLER BLOCK OFF	106	0A6313000F	1	INSULATION BRACE FRONT (UPPER)
28	0A3334	1	BAFFLE CENTERLIFT	107	0A6313000G	1	INSULATION BRACE REAR (UPPER)
29	066760	60"	STRIP SEALANT 1/8 X 1	108	0A6313000H	1	INSULATION BRACE SIDE UPPER LH
30	042561	1	CLAMP HOSE #36 1.88 - 2.75	109	0A6313000I	1	INSULATION BRACE SIDE UPPER RH
31	0A9164	1	HOSE 2.5 ID X 6 FT	110	0A6313000J	2	INSULTION BRACE SIDE UPPER (FRONT)
40	0A3133A	1	SLIP HINGE MALE LH	111	0A6313000K	2	INSULATION BRACE SIDE LOWER
41	0A3133B	1	SLIP HINGE FEMALE LH	112	0A6313000L	2	INSULATION DOOR REAR (WINDOW SIDES)
42	0A3133C	1	SLIP HINGE MALE RH	113	0A6313000M	1	INSUL. DOOR REAR (UNDER WINDOW)
43	0A3133D	1	SLIP HINGE FEMALE RH	114	0A6313000N	1	INSULATION DOOR REAR (OVER LATCH)
44 *	091089A	6	HINGE MALE RH	115	0A6313000O	1	INSULATION DOOR REAR (UNDER LATCH)
45 *	091090A	6	HINGE FEMALE RH	116	0A6313000P	2	INSULATION DOOR REAR (SIDES MANUAL HOLDER)
46	091087A	4	HINGE MALE LH	117	0A6313000Q	1	INSULATION DOOR REAR (FULL SIDES)
47	091088A	4	HINGE FEMALE LH	118	0A6313000R	8	INSULATION DOOR SIDE (UPPER & LOWER)
48	079498	1	WINDOW RECEPTACLE PANEL REAR	119	0A6313000S	4	INSULATION DOOR SIDE (OVER LATCH)
49	079497	1	WEATHERSTRIP .625 WIDTH	120	0A6313000T	4	INSULATION DOOR SIDE (UNDER LATCH)
50	091006	5	BUMPER RUBBER	121	0A6313000U	4	INSULATION DOOR SIDE (FULL SIDE)
51	089461	1	COVER LATCH (REAR DOOR)	122	0D4578000V	6	INSULATION SIDE POST GR 8.1 D/1
52	089357	4	COVER LATCH (SIDE DOOR)	123	0A6313000X	1	INSULATION DUCT REAR
53	091112	1	HOLDER MANUAL	124	0A6313000Y	1	INSULATION BAFFLE RADIATOR (UPPER-REAR)
54	0D7078	2	SCREW HHC 5/16-18 X 2-1/4 SS	125	0A6313000Z	1	INSULATION BAFFLE RADIATOR (UPPER-FRONT)
55 *	020826	1	KEY VICE ACTION LATCH	126	0A631300AA	1	INSULATION BAFFLE RADIATOR (AIR OUTLET)
56	089900	5	LATCH PADDLE	127	0A631300AB	1	INSULATION ROOF MIDDLE
57 *	089903	5	LOCK ROTARY	128	0A631300AC	1	INSULATION ROOF REAR
59 *	090129	5	ROD LATCH	129	096210	2	WASHER NYLON .375
60 *	090185	5	ROD END #10-32 RH	130	078115	14	WASHER SELF LOCKING DOME
61 *	089488	5	PLATE LATCH PIN				
62	090515	1	CABLE CONTROL PANEL				
63	089905	20	SCREW PFHM #8-32 X 3/4 SS				
64	078436	10	SCREW PPHM #8-32 X 1/2 SS				
65	090969	10	SCREW PPHM #8-32 X 2-1/8 SS				
66	083216	45	NUT LOCK HEX #8-32 SS NYL INS				
67 *	051713	15	WASHER FLAT M5				
68 *	029078	5	PIN COTTER 1/16 X 1/2				

* NOT SHOWN

Exploded View and Parts List

GR-210 Generator Set

Generator Assembly – Drawing No. 0A7632-N

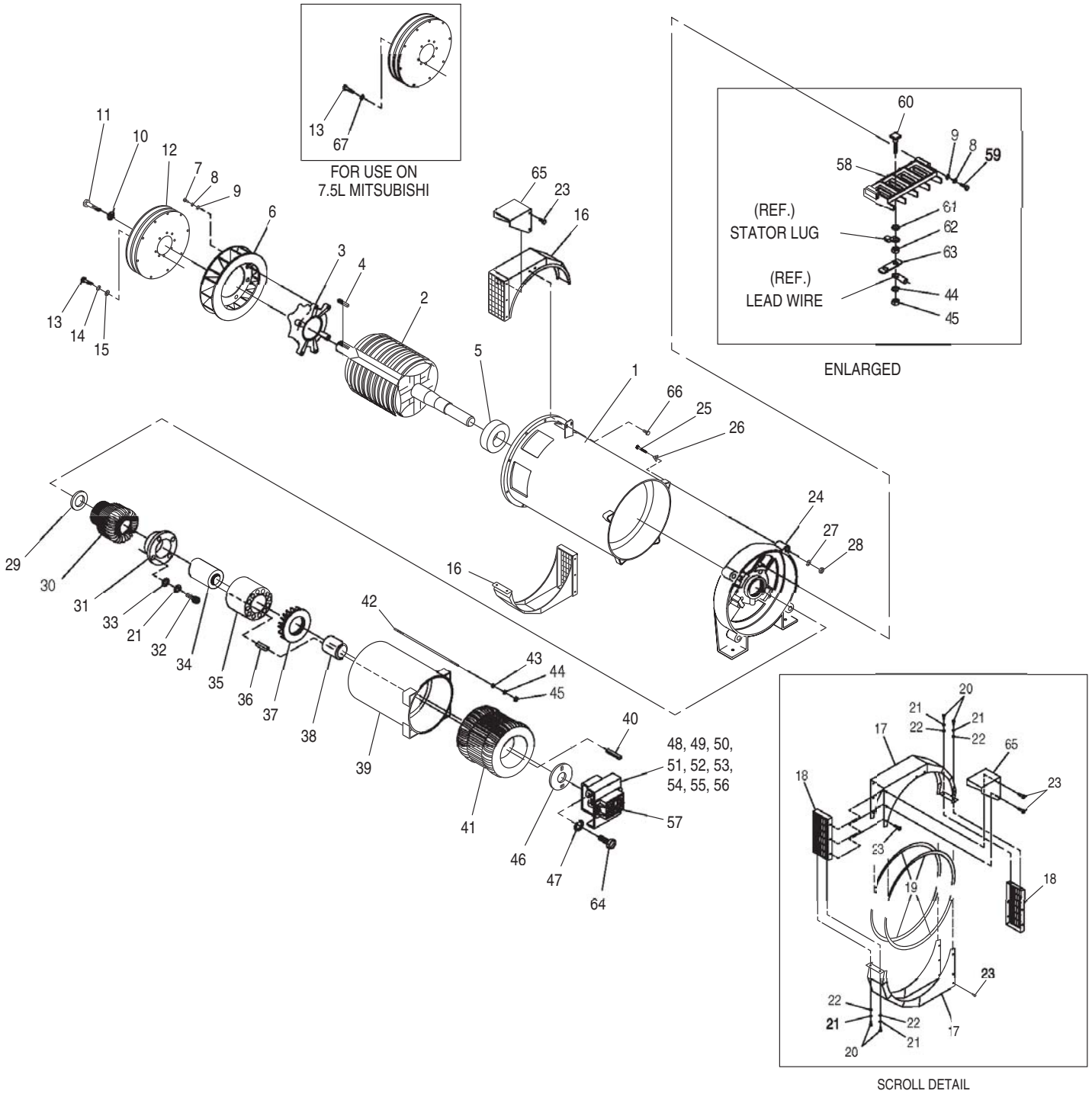

Exploded View and Parts List

GR-210 Generator Set

Generator Assembly – Drawing No. 0A7632-N

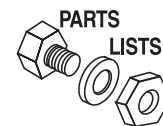

ITEM	PART NO.	QTY.	DESCRIPTION	ITEM	PART NO.	QTY.	DESCRIPTION
1	0A2865A *	1	STATOR ASSEMBLY 520 150KW	32	082460	4	SCREW SHC M6-1.0 X 65 G10.9
	0A2865B **	1	STATOR ASSEMBLY 520 200KW	33	022473	4	WASHER FLAT 1/4 ZINC
	0A2865C	1	STATOR ASSEMBLY 520 250KW	34	0A7821	1	COLLAR SLIP FIT 116.7MM
	0A2865D	1	STATOR ASSEMBLY 520 300KW	35	084828	1	HOUSING 520 PME MAGNET
	0A2865E	1	STATOR ASSEMBLY 520 350KW	36	042558	1	KEY SQ 3/8 X 1 STEEL
	0A2865L	1	STATOR ASSEMBLY 520 400KW	37	080933	1	FAN PME COOLING
	0A6424	1	STR-520-210QP2 SAE X	38	0A7807	1	COLLAR SLIP FIT 92.5MM
2	0A2851A *	1	ROTOR ASSEMBLY 520 150KW		0A7808	1	COLLAR SLIP FIT 108MM
	0A2851B **	1	ROTOR ASSEMBLY 520 200KW	39	021147	1	EXCITER FIELD 2-3/4"
	0A2851C	1	ROTOR ASSEMBLY 520 250KW		021148	1	EXCITER FIELD 3-3/4"
	0A2851D	1	ROTOR ASSEMBLY 520 300KW		0C8012	1	EXCITER FIELD 2-3/4" IRRIG.
	0A2851E	1	ROTOR ASSEMBLY 520 350KW	40	0A7662	1	KEY SQ 3/8 X 3-3/4 STEEL
	0A2851F	1	ROTOR ASSEMBLY 520 400KW		070274	1	KEY SQ 3/8 X 2-3/4 STEEL
	0A5784C	1	RTR-520-210QP2 SAE X	41	086376	1	EXCITER ASSEMBLY 2-3/4"
3	021323	1	HUB 520 DRIVE		080775	1	EXCITER ASSEMBLY 3-3/4"
4	081825 +	1	KEY SQ 16MM X 76MM STEEL	42	04576100CB	4	STUD M10-1.5 X 320 G5 ZINC
5	081831 +	1	BALL BEARING SINGLE ROW	43	022131	8	WASHER FLAT 3/8-M10 ZINC
6	0A8300 +	1	FAN 520 SAE 11-1/2	44	046526	8	WASHER LOCK M10
	0A8301	1	FAN 520 SAE 14	45	045772	8	NUT HEX M10-1.5 G8 YEL CHR
7	0A8258	6	SCREW HHC M8-1.25 X 25 G10.9	46	0A8050	1	WASHER FLAT PME
8	022129	19	WASHER LOCK M8-5/16	47	081814	1	WASHER LOCK M20
9	022145	21	WASHER FLAT 5/16 ZINC	48	098073	1	BRACKET TERMINAL MOUNT 390 PME
10	0A2716 +	1	WASHER FLAT .813 ID X 4.0 OD	49	0A8051	1	BRACKET 390 PME FRAME MOUNT
11	0A7633 +	1	SCREW HHC M20-1.5 X 35 G8.8	50	020151	2	CLAMP VINYL .312 X .203 Z
12	021322	5	PLATE FLEX SAE 11-1/2	51	089520	2	SCREW PFHM M4-0.7 X 16
	021406	5	PLATE FLEX SAE 14	52	071913	3	SCREW PFHM M5-0.8 X 16
13	059920	6	SCREW HHC M12-1.75 X 35 G10.9	53	022264	2	WASHER LOCK #8-M4
14	051769	6	WASHER LOCK M12	54	049226	3	WASHER LOCK M5
15	049808	6	WASHER FLAT M12	55	043180	2	WASHER FLAT M4
16	0A7092	1	SCROLL ASSEMBLY 520 SAE (ITEMS 17-23)	56	051713	3	WASHER FLAT M5
				57	090152	1	BRIDGE RECTIFIER ASSEMBLY
17	0A2727	2	SHROUD 520 SAE	58	092261	3	BOARD SOLID LEAD TERMINAL
18	0A2729	2	SCREEN 520 SHROUD	59	039287	6	SCREW HHC M8-1.25 X 45 G8.8
19	056326	1	TRIM VINYL BLACK 1/8 GP	60	095152	12	SCREW SHM M10-1.5 X 40.5
20	045757	4	SCREW HHC M6-1.0 X 25 G8.8	61	095586	12	WASHER FLAT .41 ID X .75 OD
21	022097	4	WASHER LOCK M6-1/4	62	096139	12	NUT HEX JAM M10-1.5
22	049811	4	WASHER FLAT M6	63	095153	6	PLATE JUMPER
23	0A2110	14	SCREW SWAGE 1/4-20 X 1/2 Z/YC	64	0A7633	1	SCREW HHC M20-1.5 X 35 G8.8
24	0A7671	1	CARRIER REAR BEARING (MACH)	65	0C8129 ***	1	DEFLECTOR 13.3L IRR
25	0A5615	4	SCREW HHC M16-2 X 170 G8.8	66	0A2437	2	SCREW SWAGE 1/4-20 X 5/8 Z/YC
26	021504	4	WASHER TRIANGLE 520 SAE	67	0D8468	6	WASHER LOCK M12 RIBBED
27	070265	4	WASHER LOCK M16				
28	0A5618	4	NUT HEX M16-2.00 G8 YEL CHR				
29	085369	1	SPACER 520 ROTOR BEARING				
30	094511	1	STATOR ASSEMBLY PME 520MM				
	0C8011	1	STATOR ASSEMBLY PME 13.3IR				
31	080934	1	RING PME STATOR RETAINING				

* NOTE: ALSO USED FOR 105KW IRRIGATION

** NOTE: ALSO USED FOR 160KW IRRIGATION

*** NOTE: USED ON 105/160KW IRRIGATION ONLY.

+ ROTOR REPLACEMENT PARTS

Exploded View and Parts List

GR-210 Generator Set

Control Panel – Drawing No. OD4358-D

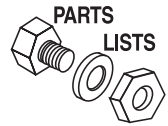

ITEM	PART NO.	QTY.	DESCRIPTION	ITEM	PART NO.	QTY.	DESCRIPTION
1	0D4220	1	CONTROL PANEL W/SILKSCREEN GR/D1	34	090512	1	HARNESS VOLTAGE REGULATOR
2	090504	1	PANEL CONTROL REAR	35	042632	1	GROMMET 1/2 X 1/16 X 3/8
3	085296	7	SCREW HHC 1/4-20 X 1/2 SS	36	064009B	1	LIGHT 12VDC .02A LED GREEN
4	083896	11	WASHER LOCK 1/4-M6 SS	37	064009	1	LIGHT 12VDC .02A LED RED PILOT
5	084929	18	WASHER FLAT 1/4-M6 SS	38	055920	1	SWITCH 1PST SPADE PANEL MOUNT
6	082495	1	ASSEMBLY ENGINE CONTROL 12/24V	39	061694	1	SWITCH SPDT 6A SPD CTR OFF TOG
7	064525	4	STANDOFF HEX 3/4	40	061943	1	SWITCH DPST 15A SPD PROG TGGL
8	064526	8	SCREW TAP HWH #6-25 X 3/8 Z	41	023897	2	WASHER FLAT #10 ZINC
9	074386	1	SWITCH SELECTOR 3PH VOLT/AMP	42	036261	6	RIVET POP .125 X .129-.133/#30
10	055349	1	INSULATOR	43	028739	3	TIE WRAP 4" WHITE
11	053693	1	POTENTIOMETER PNL 10K +/-10% 2.25W	44	044213	1	RESISTOR MISC 10R X 12W
12	050123	1	KNOB PLASTIC	45	022152	2	WASHER LOCK #10
13	049350	1	BREAKER (FIELD BOOST) 4 AMP	46	033138	2	SCREW HHM #10-32 X 5/8
14	0C2428	4	SCREW TAPTITE PH #6-32 X 1/2 Z/YC	48	070202	1	LIGHT PANEL #26306C
15	022155	4	WASHER LOCK #6	49	025192	1	RECTIFIER MSC 2A 600V 1N5062
16	022206	1	FITTING STRAIGHT 3/8	50	070082	1	BLOCKER LIGHT
17	063617	1	RELAY PANEL 12VDC DPDT 10A@240VA	51	0D4861	1	HARNESS CONTROL PANEL GR D/1
18	022985	2	WASHER FLAT #6-M4	52	0A1661	2	RIVET POP .156 X .160-.164/#20
19	057701	1	BLOCK TERMINAL 20A 8 X 6 X 1100V	53	057405	1	RESIST MISC 25R X 25W
20	046669	3	BLOCK TERMINAL JUMPER FOR S141	54	064733	2	BRACKET RESISTOR MOUNTING
21	090513	1	DECAL TERMINAL STRIP	57	0E6871	1	RECTIFIER ASSEMBLY
22	067680	1	ASSEMBLY VOLTAGE REGULATOR 60HZ	60	032300	1	HOLDER FUSE
23	033135	4	SCREW HHM #8-32 X 1/2	61	022676	1	FUSE 15A X AGC15
24	022264	4	WASHER LOCK M4	62	085889	7	NUT HEX 1/4-20 SS
25	038150	4	WASHER FLAT #8 ZINC	63	022717A	1	GROMMET 3/8 X 1/16 X 1/4
26	022471	4	NUT HEX #8-32 STEEL	64	048766	1	BLOCK TERMINAL 20A 2 X 6 X 1100V
27	079983	1	VOLTMETER DUAL	65	0D4561	2	SCREW TAPTITE #6-32 X 5/8 BP
28	070060	1	AMMETER AC 0 - 800	66	022155	2	WASHER LOCK #6
29	070042	1	METER FREQUENCY 55-65 HZ	67	022985	2	WASHER FLAT #6 ZINC
30	055406	1	GUAGE COOLANT TEMPERATURE	68	064828	1	DECAL TRAN SW CONN
31	055405	1	GUAGE OIL PRESSURE	69	095196	1	DECAL- CHK OIL & H2O
32	062304	1	AMMETER 40-0-40 DC	70	0E3783	1	DECAL, WARNING REMOVE FUSE
33	070081	1	METER HOURS				



Exploded View and Parts List

GR-210 Generator Set

Battery Charger – Drawing No. 0D3490-E

REAR CUTAWAY VIEW OF PC BOARD
MOUNTED TO BOTTOM OF INNER WALL

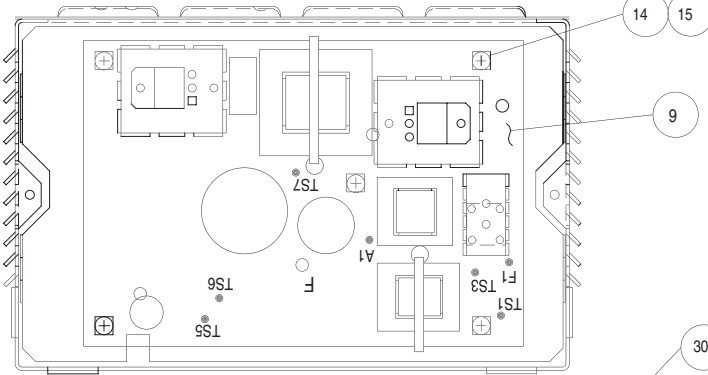

LOCATED ON
OUTSIDE TOP

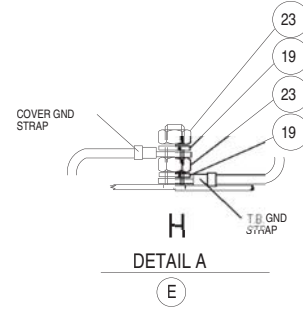

FRONT VIEW OF INNER WALL WITH
TERMINAL BLOCK & DECAL

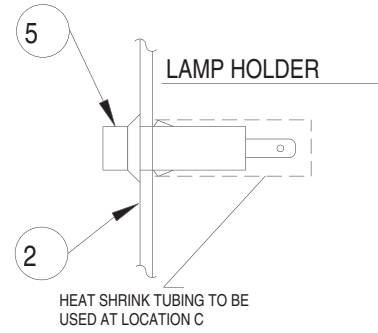
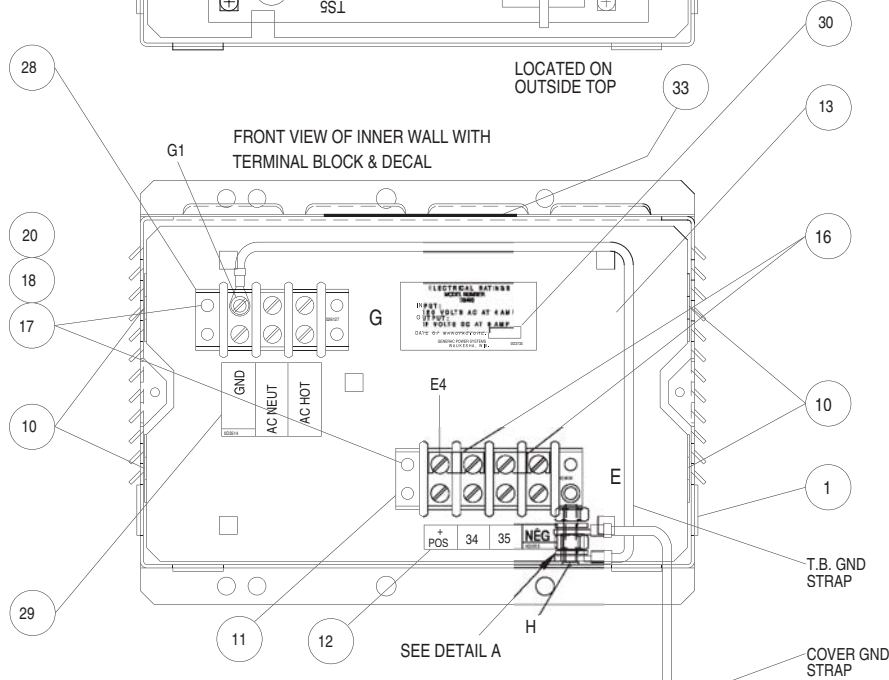

INSIDE OF FRONT COVER

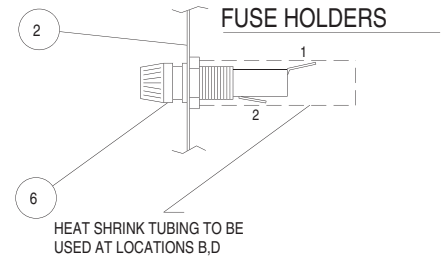
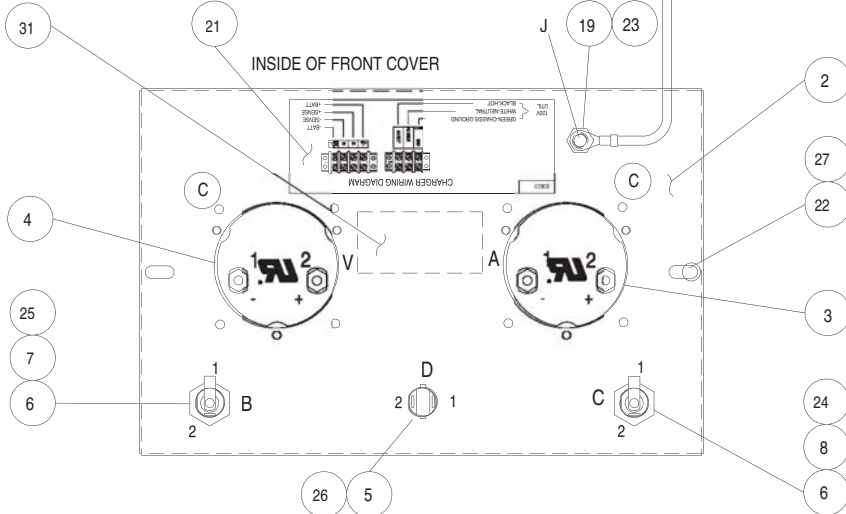

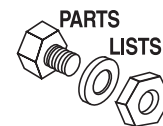
Exploded View and Parts List**GR-210 Generator Set****Battery Charger – Drawing No. 0D3490-E**

ITEM	PART NO.	QTY.	DESCRIPTION
1	0C2943	1	BATT. CHARGER BOX
2	0D5254	1	SILKSCREEN COVER DUAL METER 12
3	061526	1	AMMETER 0-15ADC 2-1/2"
4	061527	1	VOLTMETER 0-15VDC 2-1/2"
5	061525	1	LIGHT 120V NEON LAMP/HOLDER
6	032300	2	HOLDER FUSE
7	067682B	1	FUSE 4A SLO BLO GLASS
8	0D7178B	1	FUSE 12AMP LITT 3AB-12 314012
9	067666C	1	ASSY PCB BATT CHRG 10A 12/120V
10	024911	4	SCREW HHTT #8-32 X 3/8 CZ
11	039608	1	BLOCK TERM 30A 4 X 8 X 1600V
12	0D3615	1	DECAL, TB, 4POS, BATCHRG, 12&24V
13	0D3670	1	INNER WALL, 12/24V, 10A, BATCHRG
14	072566A	5	NUT, SPACER .375 PCB
15	079529	5	PPHTC SCREW M4.2X16
16	023827	2	BLOCK TERM JUMPER FOR S142/542
17	022158	4	NUT HEX #10-32 STEEL
18	022152	4	WASHER LOCK #10
19	022097	3	WASHER LOCK M6-1/4
20	036934	4	SCREW PPHM #10-32 X 5/8
21	0D3633	1	DECAL, BATTCHRG, 12&24V, WIRING
22	056893	2	SCREW CRIMPTITE 10-24 X 1/2
23	049813	3	NUT HEX M6 X 1.0 G8 YEL CHR
24	080858	1	SHRINK TUBING .625"ID BLK(2-3/8"LG)
25	080858	1	SHRINK TUBING .625"ID BLK(1-3/4"LG)
26	080858	1	SHRINK TUBING .625"ID BLK(1-1/2"LG)
27	052621	2	WASHER NYLON .200
28	026127	1	BLOCK TERM 30A 3 X 8 X 1600V
29	0D3614	1	DECAL, TB, 3POS, BATCHRG 12&24V
30	0D3733	1	DECAL, ELECTRIC, RATE, D3490 B.C
31	0D3930	1	DECAL, CAUTION BATT CHRG 12/24
32	0D3490W	1	WIRE-BATTERY CHARGER 12 VOLT
33	0D7551	1	DECAL WARNING BATTERY

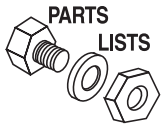

Exploded View and Parts List

GR-210 Generator Set

Receptacle Panel – Drawing No. 0D4355-E

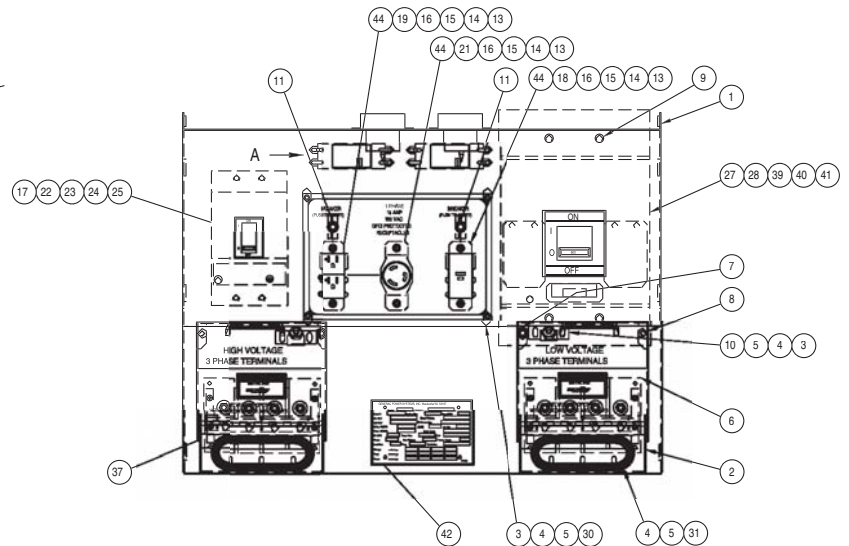
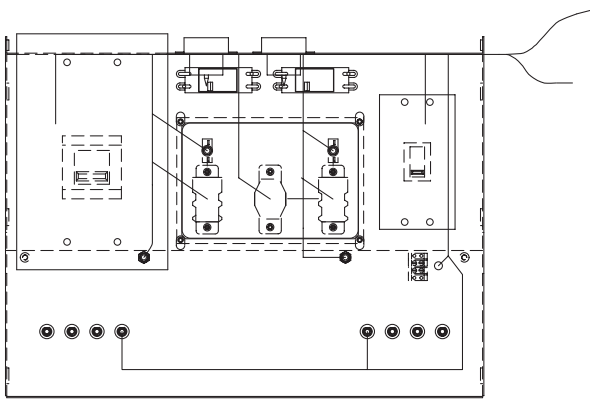
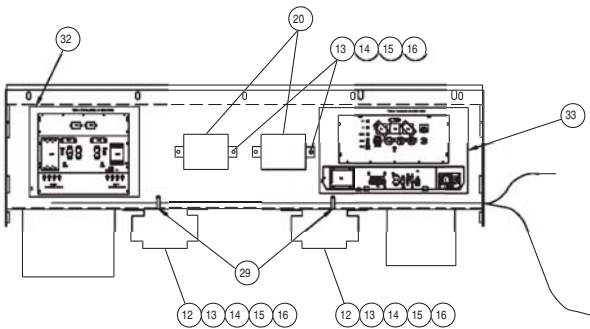

ITEM	PART NO.	QTY.	DESCRIPTION	ITEM	PART NO.	QTY.	DESCRIPTION
1	0D2309	1	PANEL RECEPTACLE W/SILKSCREEN (GR-160)	25	081524U	1	CIRCT BRK 225 X 3 600V 3P (GR-160)
	0A8041	1	PANEL RECEPTACLE W/SILKSCREEN (GR-190 & 210)		081526U	1	CIRCT BRK 300 X 3 600V (GR-190 & 210)
2	0A9321	1	ASSEMBLY LUG BOX LOW 8.1	27	037287	4	SCREW HHC 5/16-18 X 5-1/4 G5
3	085296	16	SCREW HHC 1/4-20 X 1/2 SS	28	081530U	1	CIRCT BRK 600 X 3 600V (GR-160 & 190)
4	083896	22	WASHER LOCK 1/4-M6 SS		081531U	1	CIRCT BRK 700 X 3 600V (GR-210)
5	084929	22	WASHER FLAT 1/4 SS	29	029333	2	TIE WRAP 7.4" X .19"
6	0A5572	2	ASSEMBLY LUG BLOCK	30	0A7832	1	PLATE PANEL RCPTCL W/SILKSCREEN
7	055920	2	SWITCH SPST SPADE PNL MNT	31	083895	8	SCREW HHC 1/4-20 X 1 SS
8	032990	2	BUMPER RUBBER	32	091150	1	DECAL RECEPTACLE PANEL
9	065511	12	PLUG BUTTON 1/2"	33	091149	1	DECAL CONTROL PANEL
10	0A2081	2	HASP LUG BOX DOOR	34	095910	1	WRENCH HEX 3/8" T-HANDLE (NOT SHOWN)
11	075207	2	CIRCT BRK 15 X 2 UL/CSA SANG MAO	35	046228	2"	SHRINK TUBING 3/8" ID CLEAR (NOT SHOWN)
12	083331	2	CIRCT BRK 50 X 2 240V SQUARE D	36	065852A	2	SPRING CLIP .37"- .62" VINYL (NOT SHOWN)
13	078436	16	SCREW PPHM #8-32 X 1/2 SS	37	0A9320	1	ASSEMBLY LUG BOX HIGH 8.1
14	078437	16	WASHER LOCK #8-M4 SS	38	0D5616	1	HARNESS PANEL CONTROL (NOT SHOWN)
15	078438	14	NUT HEX #8-32 SS	39	022259	4	NUT HEX 5/16-18 STEEL
16	080490	40	WASHER FLAT #8 SS	40	022145	8	WASHER FLAT 5/16 ZINC
17	040295	4	WASHER LOCK #10 SS	41	022129	4	WASHER LOCK M8-5/16
18	080410	1	RECEPTACLE BLANK FACE GFCI 20A	42	0A5073	1	PLATE DATA
19	080409	1	RECEPTACLE DUPLEX GFCI 20 AMP	43	0C1940	1	LOOSE WIRES GR-160, 190, 210 (NOT SHOWN)
20	079486	2	OUTLET 120/240 VOLT	44	026579	6	WASHER SHAKEPROOF EXT #8 STEEL
21	074190	1	OUTLET 20A 125V NEMA L5-20R				
22	090427	8	WASHER FLAT #10 SS				
23	040292	4	NUT HEX #10-32 SS				
24	022818G	4	SCREW IHHM #10-32 X 4-1/2				

Exploded View and Parts List

GR-210 Generator Set

Connection Panel – Drawing No. OD3450-A

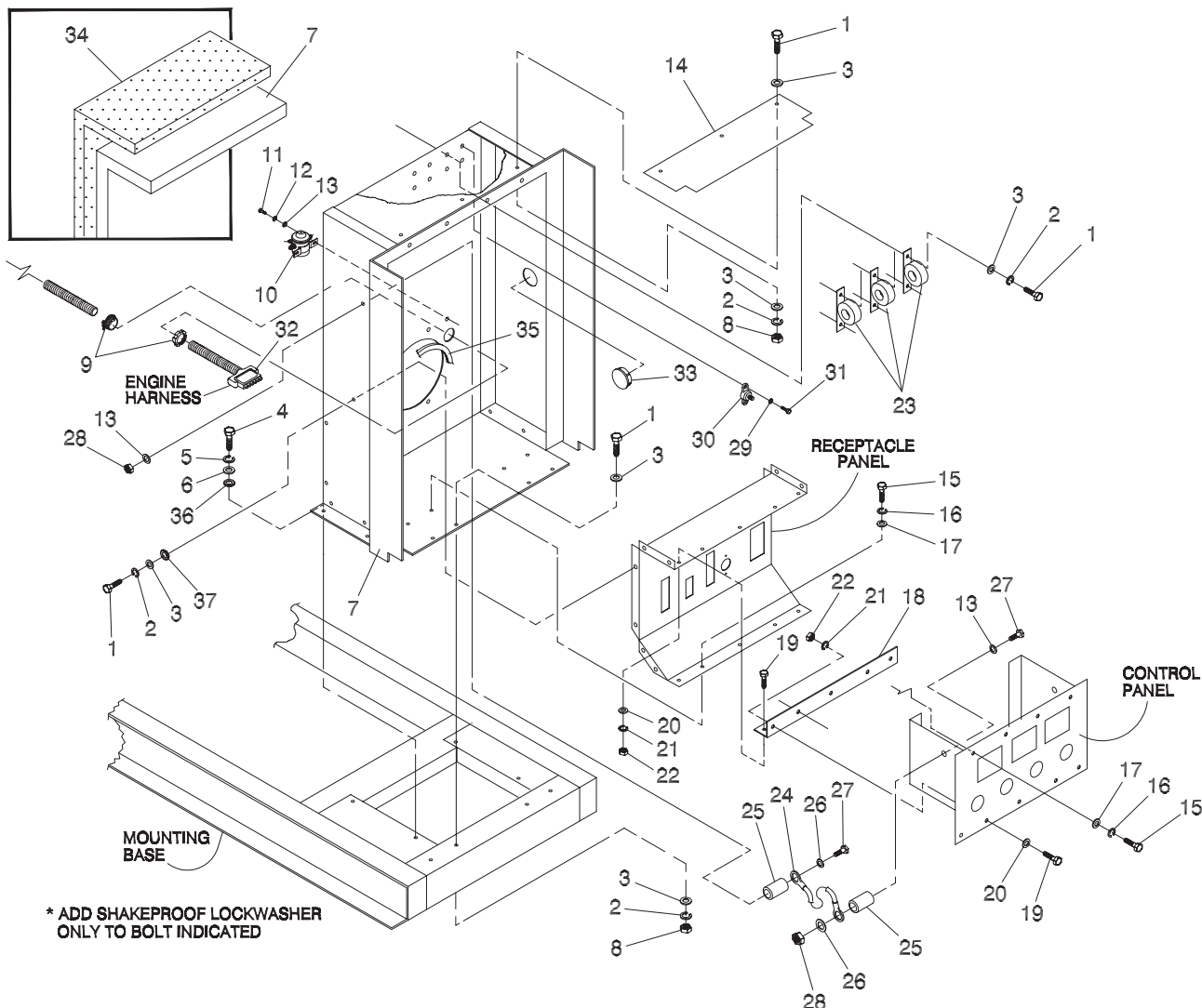
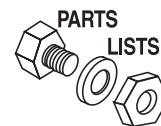

ITEM	PART NO.	QTY.	DESCRIPTION	ITEM	PART NO.	QTY.	DESCRIPTION
1	070013	23	SCREW HHC 5/16-18 X 3/4 SS VIB	20	090427	10	WASHER FLAT #10 SS
2	070006	23	WASHER LOCK M8 SSTL	21	040295	10	WASHER LOCK #10 SS
3	090977	32	WASHER FLAT .375 ID X .875 OD	22	040292	10	NUT HEX #10-32 SSTL
4	029745	4	SCREW HHC 3/8-16 X 1 G5	23	059926	3	TRANSFRM 800A TO 5A
5	022237	4	WASHER LOCK 3/8	24	090515	1	CABLE CONTROL PANEL
6	022131	4	WASHER FLAT 3/8-M10 ZINC	25	038196	2	SPACER .28 X .62 X .19 STL/ZNC
7	0A3864	1	ASSY CNTL BOX PANEL	26	054381	2	WASHER FLAT .266 ID X 1.0 OD
8	082351	9	NUT HEX 5/16-18 SSTL	27	022287	2	SCREW HHC 1/4-20 X 3/4 G5
9	034616	1	FITTING STRAIGHT 3/4	28	050993	2	NUT LOCK HEX INDENT 1/4-20
10	056739	1	RELAY SOLENOID 12VDC PNL MNT	29	023897	2	WASHER FLAT #10 ZINC
11	022507	2	SCREW HHC 1/4-20 X 1/2 G5	30	057073	1	BLOCK JUNCTION 3/8-16
12	022097	2	WASHER LOCK M6-1/4	31	033530	2	SCREW PHM #10-32 x 5/8 CAD
13	022473	4	WASHER FLAT 1/4 ZINC	32	055089	1	CONN PLUG PNL 15P AMP M-N-L
14	090425	1	BAFFLE UPPER RECEPTACLE PANEL	33	058221	1	PLUG PLASTIC 1.750 BLACK
15	085296	10	SCREW HHC 1/4-20 X 1/2 SS	34	0A8281000A	1	INSULATION CONTROL BOX
16	083896	10	WASHER LOCK 1/4-M6 SS	35	056326	13"	TRIM VINYL BLACK 1/8 GP
17	084929	10	WASHER FLAT 1/4 SS	36	022261	1	WASHER SHAKEPROOF INT 3/8
18	089487	1	HINGE CONTROL PANEL	37	026204	1	WASHER SHAKEPROOF INT 5/16
19	090426	10	SCREW PPHM #10-32 X 3/8 SS				



Exploded View and Parts List

GR-210 Generator Set

Radiator Assembly – Drawing No. 0A8316-C

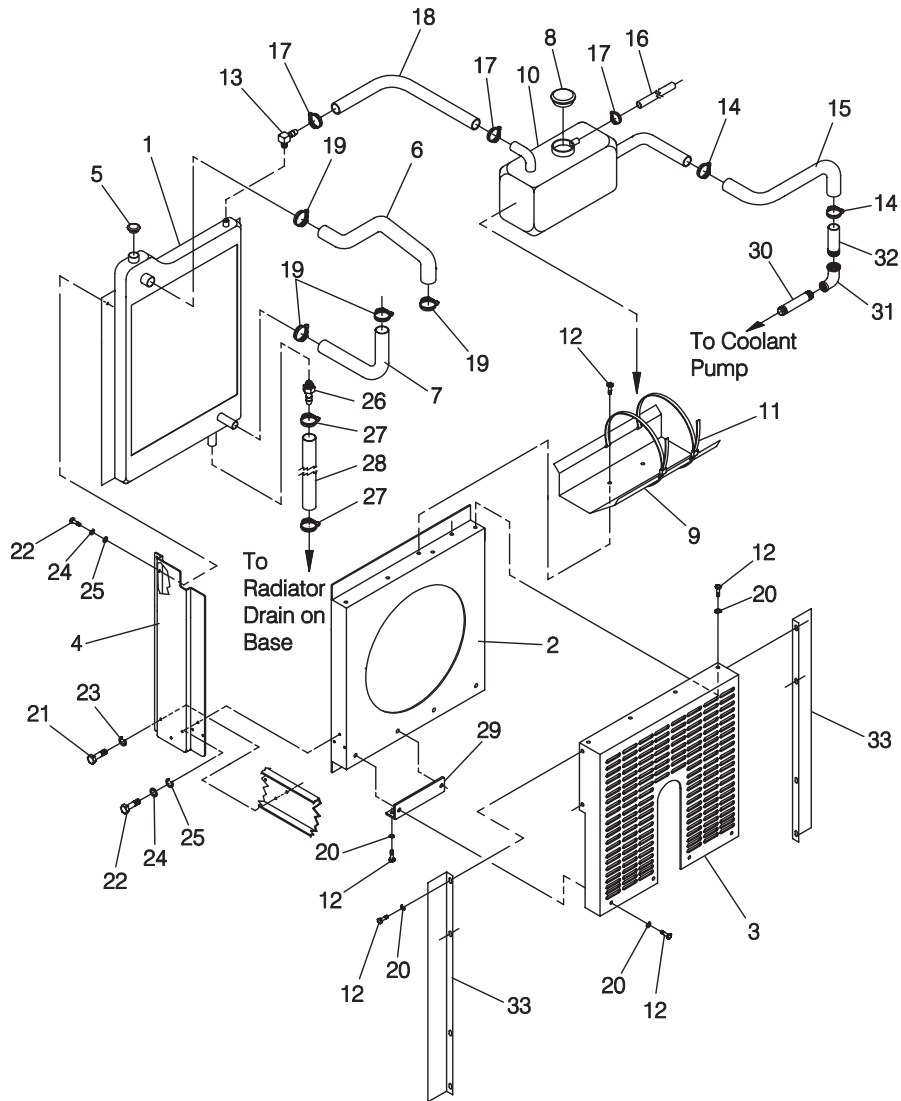

ITEM	PART NO.	QTY.	DESCRIPTION	ITEM	PART NO.	QTY.	DESCRIPTION
1	0A6485	1	RADIATOR, 8.1L J.D.	17	040173	3	CLAMP, HOSE #5.5 .62-.62
2	0A6296	1	VENTURI, 8.1L J.D.	18	029032	1	HOSE, 9/32 ID
3	0A6298	1	FAN GUARD, 8.1L J.D.	19	042561	4	CLAMP, #36 HOSE 1.88-2.75
4	0A6295A	1	RADIATOR SIDE SUPPORT, L.H.	20	022097	18	WASHER, LOCK M6-1/4
	0A6295B	1	RADIATOR SIDE SUPPORT, R.H.	21	039436	6	SCREW HHC, 1/2"-13 x 3/4" G5
5	046627	1	CAP, RADIATOR	22	029745	12	SCREW HHC, 3/8"-16 x 1" G5
6	0A6293	1	RADIATOR HOSE, OUTLET 8.1L	23	022195	6	WASHER, LOCK-1/2"
7	0A6292	1	RADIATOR HOSE, INLET 8.1L	24	022237	12	WASHER, LOCK-3/8"
8	090283	1	CAP, RADIATOR 13 PSI	25	022131	12	WASHER, FLAT-3/8" M10 ZINC
9	099448	1	SUPPORT, SURGE TANK	26	035461	1	BARBED ST-1/4" NPT x 3/8
10	090097	1	TANK, SURGE	27	035472	2	CLAMP, HOSE #6 .43-.78
11	058612	2	CLAMP, HOSE #88 5.12-6.00	28	047290	1	HOSE, 3/8" I.D. SINGLE BRAID
12	022287	18	SCREW HHC. 1/4"-20 x 3/4" G5	29	0A6428	2	LOWER FAN GUARD 8.1L
13	059502	1	BARBED EL 90 1/4" NPT X 5/16	30	030420	1	NIPPLE PIPE 1/2 NPT X 5
14	057824	2	CLAMP, HOSE-#16 .87-1.50	31	026739	1	ELBOW, RED STREET 3/4 X 1/2
15	035587	1	HOSE, 1" I.D. CVR NEOP SAE-20R3"	32	028641	1	NIPPLE TOE 3/4 NPT X 2
16	029032	1	HOSE, 9/32 ID	33	0C7447	2	RADIATOR BLOCK OFF

Exploded View and Parts List
GR-210 Generator Set
Block Heater – Drawing No. 0D3593

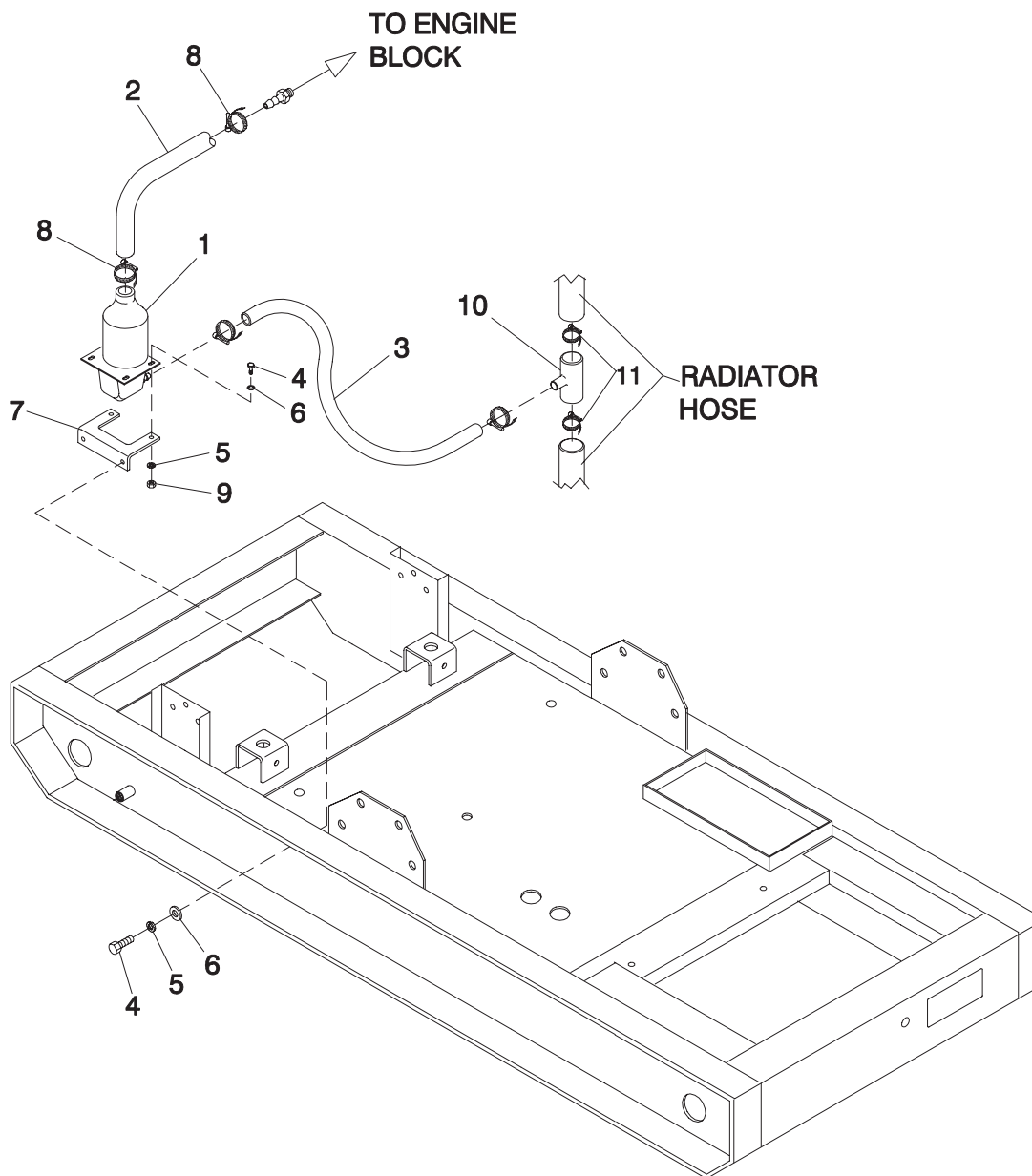
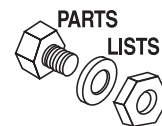

ITEM	PART NO.	QTY.	DESCRIPTION
1	084918C	1	HEATER ENGINE 1800W 120V
2	050967	20"	HOSE 5/8 ID RIA 250F
3	050967	24"	HOSE 5/8 ID RIA 250F
4	042568	4	SCREW HHC M6-1.0 X 20 G8.8
5	022097	4	WASHER LOCK M6-1/4
6	049811	4	WASHER FLAT M6
7	084427	1	BRACKET HEATER
8	057822	4	CLAMP HOSE #8 .53-1.00
9	049813	2	NUT HEX M6 -1.0 G8 YEL CHR
10	080723	1	HOSE CONNT. 1.75-.62
11	042561	2	CLAMP HOSE #36 1.88-2.75

NOTE: PUT ITEM #10 IN RADIATOR HOSE.

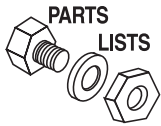

Exploded View and Parts List

GR-210 Generator Set

Battery Charger – Drawing No. 091237-H

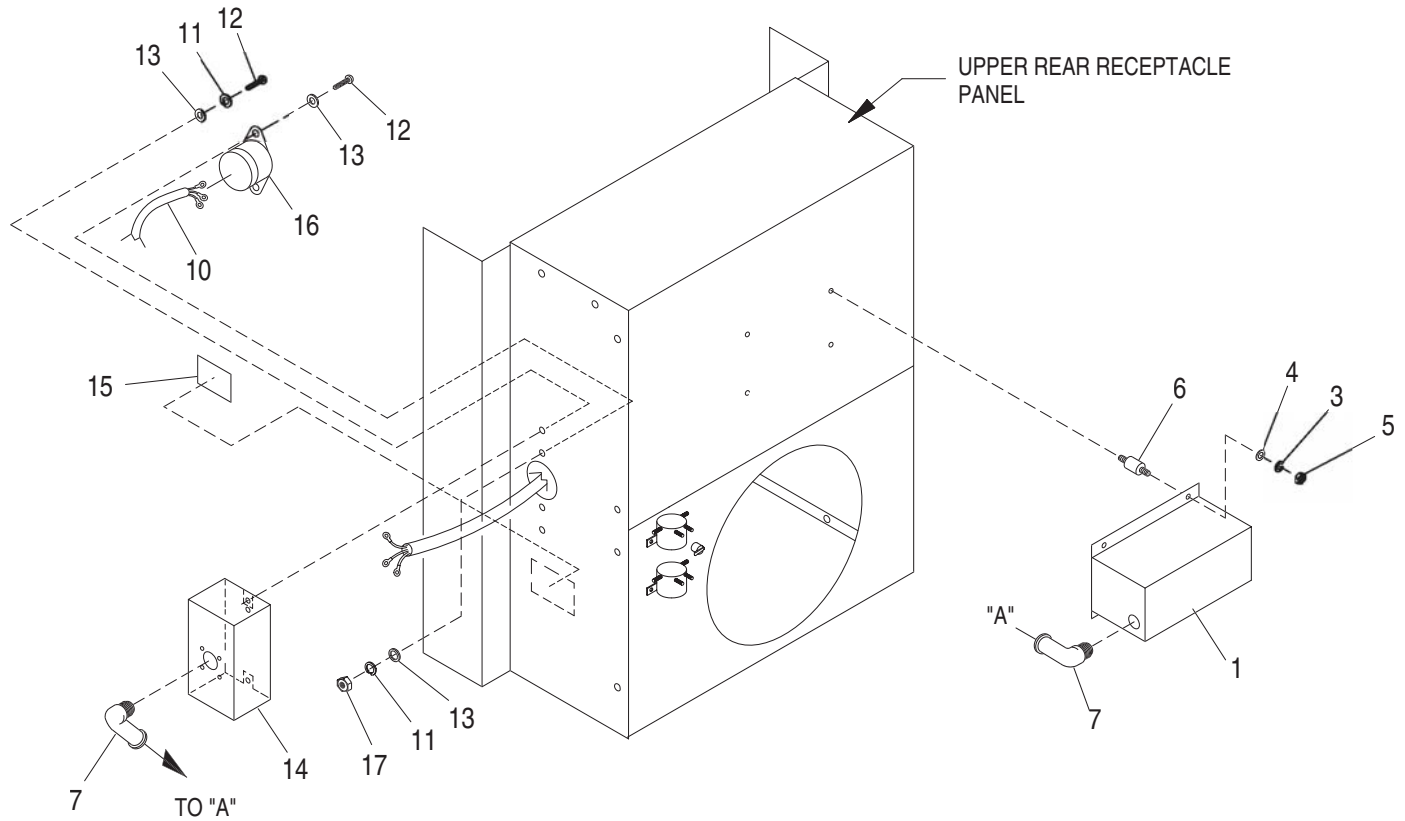

ITEM	PART NO.	QTY.	DESCRIPTION
1	0D3490	1	ASSY BATTERY CHAGER 12V 10AMP
	0D4687	1	BATTERY CHARGER ASSY,12V,2A,UL
3	022097	4	WASHER LOCK M6-1/4
4	022473	4	WASHER FLAT M6-1/4 ZINC
5	022127	4	NUT HEX 1/4-20 STEEL
6	027831	4	MOUNT VIBR .50 X 1.0 X .50
7	060015	2	FITTING 90 DEGREE 3/8
10	088670	1	ASSEMBLY WIRE-BATTERY CHARGER
11	081797	4	WASHER LOCK 6 SS
12	091198	4	SCREW PPHM #6-32 X 5/8 SS
13	081799	8	WASHER FLAT #6-M4 SS
14	062141	1	OUTLET BOX
15	091233	1	DECAL UTILITY CONNECTION
16	069174	1	RECEPTACLE MALE SS
17	081798	2	NUT HEX #6-32 SS
**	055934C	1	CLAMP VINYL .5 X .406 Z
**	090679	1	HARNESS BATTERY CHARGER

** NOT SHOWN



Warranty

GR-210 Generator Set

CALIFORNIA EMISSION CONTROL WARRANTY STATEMENT (CALIFORNIA ONLY)

Your Warranty Rights and Obligations

The California Air Resources Board (CARB) and John Deere are pleased to explain the emission control system on your new engine. In California, new heavy-duty engines must be designed, built, and equipped to meet the State's stringent anti-smog standards. John Deere must warrant the emission control system on your engine for the periods of time listed below provided there has been no abuse, neglect, or improper maintenance of your engine.

Your emissions control system includes:

- Fuel Metering System
 - Fuel Injection System
- Air Induction System
 - Intake Manifold
 - Turbocharger System
 - Charge Air Cooling System
- Miscellaneous Items used in above systems

Where a warrantable condition exists, i.e. failure due to defect in John Deere-supplied material and/or workmanship, John Deere will repair your heavy-duty engine at no cost to you including diagnosis, parts and labor.

JOHN DEERE'S WARRANTY COVERAGE:

The emission control system of your heavy-duty engine is warranted for five years or 3000 hours of operation, whichever occurs first. If any emission-related part on your engine is defective, the part will be repaired or replaced by John Deere. Warranties stated in this manual refer only to emissions-related parts and components of your engine. The complete engine warranty, less emissions-related parts and components, is provided separately as the "John Deere New Off-Highway Engine Warranty".

Part 2

**OWNER'S WARRANTY RESPONSIBILITIES:**

As the heavy-duty engine owner, you are responsible for the performance of the required maintenance as outlined in this Operation and Maintenance Manual. John Deere recommends that you retain all receipts covering maintenance on your heavy-duty engine, but John Deere cannot deny warranty solely for the lack of receipts or for your failure to ensure the performance of all scheduled maintenance.

However, as the heavy-duty engine owner, you should be aware that John Deere may deny you warranty coverage if your heavy-duty engine or a part has failed due to abuse, neglect, improper maintenance or unapproved modifications.

Your engine is designed to operate on diesel fuel only. Use of any other fuel may result in your engine no longer operating in compliance with California's emissions requirements.

You are responsible for initiating the warranty process. The CARB suggests that you present your heavy-duty engine to the nearest John Deere engine service dealer as soon as a problem is suspected. The warranty repairs should be completed by the service dealer as expeditiously as possible.

If you have any questions regarding your warranty rights and responsibilities, you should contact John Deere at 1-319-292-5400 or the State of California Air Resources Board, Mobile Source Operation Division, PO Box 8001, El Monte, CA 91731-2990.

The warranty period begins on the date the engine is delivered to an ultimate purchaser, or when otherwise put into service. John Deere warrants to the ultimate purchaser and each subsequent purchaser that the engine is designed, built, and equipped so as to conform with all applicable regulations adopted by the Air Resources Board, and that it is free from defects in materials and workmanship which would cause the failure of a warranted part.

Any warranted part which is scheduled for replacement as required maintenance by this Operation and Maintenance Manual is warranted by John Deere for the period of time prior to the first scheduled replacement point for that part. If the part fails prior to the first scheduled replacement point, the part shall be repaired or replaced under the warranty. Any such part repaired or replaced under warranty is warranted for the remainder of the period prior to the first scheduled replacement point for the part.

Any warranted part which is not scheduled for replacement as required maintenance, or which is scheduled only for regular inspection to the effect of repairing or replacing as necessary, is warranted for the warranty period.

Repair or replacement of a warranted part will be performed at no charge to you by a John Deere engine service dealer. You will not be charged for diagnostic labor which leads to the determination that a warranted part is defective, if the diagnostic work is performed by a John Deere engine service dealer.

John Deere is liable for damages to other engine components caused by the failure under warranty of any warranted part.

Any replacement part may be used in the performance of any maintenance or repairs, and such use will not reduce the warranty obligations of John Deere. However, the use of add-on or modified parts are grounds for disallowing a warranty claim.

Part 3



Warranty

GR-210 Generator Set

GENERAC POWER SYSTEMS STANDARD TWO-YEAR LIMITED WARRANTY FOR GR SERIES/PRIME POWER UNITS

NOTE: ALL UNITS MUST HAVE A STARTUP INSPECTION PERFORMED BY AN AUTHORIZED GENERAC DEALER.

For a period of 2 (two) years or 3,000 (three thousand) hours of operation from the date of sale, which ever occurs first, Generac Power Systems, Inc. will, at its option, repair or replace any part(s) which, upon examination, inspection, and testing by Generac Power Systems or a Generac Power Systems Authorized Warranty Service Facility, is found to be defective under normal use and service, in accordance with the warranty schedule set forth below. Any equipment that the purchaser/owner claims to be defective must be returned to, and examined by the nearest Generac Power Systems Authorized Warranty Service Facility. All transportation costs under the warranty, including return to the factory, are to be borne and prepaid by the purchaser/owner. This warranty applies only to Generac Power Systems Generators used in "Prime Power/Mobile" applications, as Generac Power Systems, Inc. have defined Prime Power/Mobile, provided said generator has been initially installed and inspected on-site by a Generac Power Systems Authorized Service Dealer or branch thereof. A scheduled maintenance agreement with a local Authorized Generac Power Systems Dealer is highly recommended to verify adequate service has been performed on the unit throughout the warranty period. Limited to, and available only on Liquid-cooled units.

WARRANTY SCHEDULE

YEAR ONE — 100% (one hundred percent) coverage on mileage*, labor, and parts listed.

• **ALL COMPONENTS**

YEAR TWO — 100% (one hundred percent) coverage on parts listed.

• **ALL COMPONENTS — *PARTS ONLY**

- *Travel allowance is limited to 300 miles maximum, or 7.5 hours maximum (per occurrence), **round trip**, to the nearest Generac Service Facility.
- A Generac Power Systems, Inc. Transfer Switch is highly recommended to be used in conjunction with the genset. If a Non - Generac Power Systems, Inc. Transfer Switch is substituted for use and directly causes damage to the genset, no warranty coverage shall apply.
- All warranty expense allowances **are** subject to the conditions defined in Generac Power Systems Warranty, Policies, and Procedures Flat Rate Manual.
- Trailer/Mobile units that have been resold **are** covered under the Generac Power Systems Warranty, as this Warranty **is** transferable. A transfer fee of \$100.00 plus a complete inspection report that indicates the unit has been maintained and is in proper working order, **must be** received within 30 days of the date of sale or all warranty on the unit **will be** null and void. The warranty time frame is from the original in-service/start-up date of the unit provided all fees and documentation have been completed.

THIS WARRANTY SHALL NOT APPLY TO THE FOLLOWING:

1. Any unit built/manufactured prior to January 1, 2002.
2. Unit enclosure is only covered against rust or corrosion the first year of the warranty provision.
3. Costs of normal maintenance i.e. tune-ups, associated part(s), adjustments, loose/leaking clamps, installation and start-up.
4. Use of Non-Generac replacement part(s) will void the warranty in its entirety.
5. Any failure caused by contaminated fuels, oils, coolants/antifreeze or lack of proper fuels, oils or coolants/antifreeze.
6. Units sold, rated or used for "Standby Power" applications as Generac Power Systems have defined Standby Power. Contact a Generac Power Systems Distributor for Standby Power definition and warranty.
7. Failures due, but not limited to, normal wear and tear, accident, misuse, abuse, negligence, or improper installation or sizing.
8. Failures caused by any external cause or act of God such as collision, fire, theft, freezing, vandalism, riot or wars, lightning, earthquake, windstorm, hail, volcanic eruption, water or flood, tornado, hurricane, terrorist acts or nuclear holocaust.
9. Products that are modified or altered in a manner not authorized by Generac Power Systems in writing.
10. Any incidental, consequential or indirect damages caused by defects in materials or workmanship, or any delay in repair or replacement of the defective part(s).
11. Failure due to misapplication, misrepresentation, or bi-fuel conversion.
12. Telephone, telegraph, teletype or other communication expenses.
13. Living or travel expenses of person(s) performing service, except as specifically included within the terms of a specific unit warranty period.
14. Rental equipment used while warranty repairs are being performed i.e. rental generators, cranes, etc..
15. Overtime labor or more than one person performing repairs.
16. Any and all expenses incurred investigating performance complaints unless defective Generac materials and or workmanship were the direct cause of the problem.
17. *Engine coolant heaters (block-heaters), heater controls and circulating pumps after the first year.
18. *Starting batteries, fuses, light bulbs, engine fluids, and overnight freight cost for replacement part(s).

THIS WARRANTY IS IN PLACE OF ALL OTHER WARRANTIES, EXPRESSED OR IMPLIED, SPECIFICALLY, GENERAC POWER SYSTEMS MAKES NO OTHER WARRANTIES AS TO THE MERCHANTABILITY OR FITNESS FOR A PARTICULAR PURPOSE. Some states do not allow limitations on how long an implied warranty lasts, so the above limitation may not apply to you.

GENERAC POWER SYSTEMS ONLY LIABILITY SHALL BE THE REPAIR OR REPLACEMENT OF PART(S) AS STATED ABOVE. IN NO EVENT SHALL GENERAC POWER SYSTEMS BE LIABLE FOR ANY INCIDENTAL, OR CONSEQUENTIAL DAMAGES, EVEN IF SUCH DAMAGES ARE A DIRECT RESULT OF GENERAC POWER SYSTEMS, INC. NEGLIGENCE. Some states do not allow the exclusion or limitation of incidental or consequential damages, so the above limitations may not apply to you. Purchaser/owner agrees to make no claims against Generac Power Systems, Inc. based on negligence.

This warranty gives you specific legal rights. You also may have other rights that vary from state to state.

GENERAC® POWER SYSTEMS, INC. · P.O. BOX 8 · WAUKESHA, WI 53187
PH: (262) 544-4811 · FAX: (262) 544-4851

Bulletin 0166300SBY / Printed in USA 5.02