

Barber-Colman Integrated Actuator for Stanadyne "D" Series Injection Pump — Model DYNA 70025

Installation Procedure

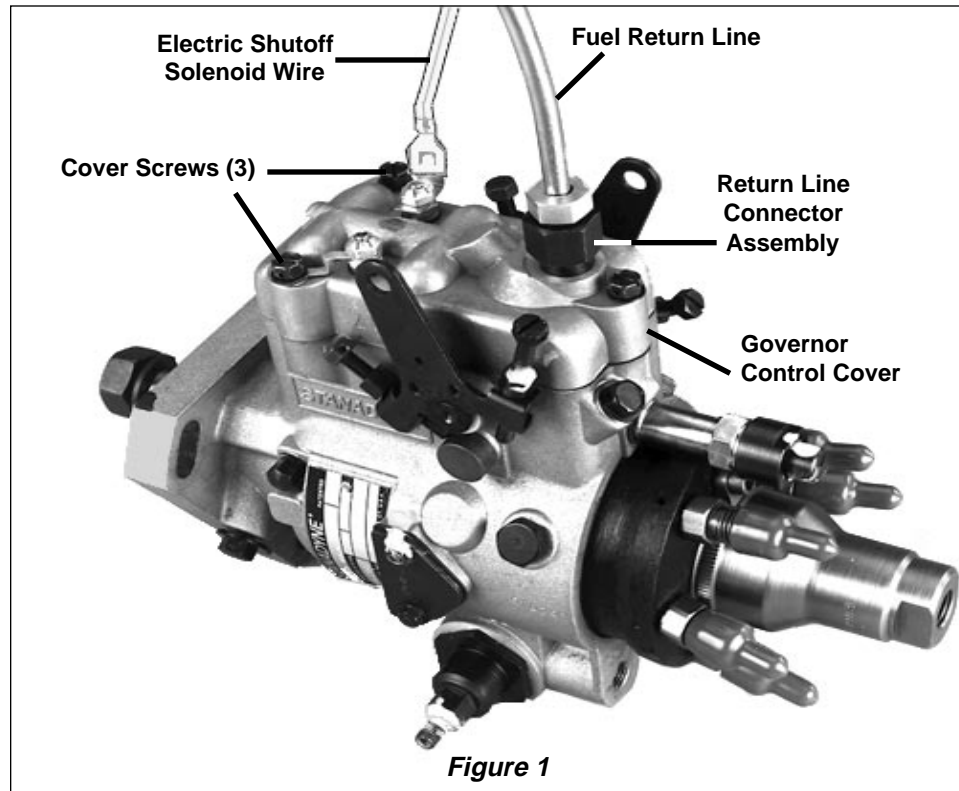

Figure 1

STEP I

REMOVAL OF EXISTING GOVERNOR CONTROL COVER

— NOTE —

Clean outside of pump with solvent and dry with compressed air prior to removing the GOVERNOR CONTROL COVER. A suitable container should be placed underneath the fuel injection pump to catch any fuel that may spill when removing the GOVERNOR CONTROL COVER.

1.0 Remove the FUEL RETURN LINE from the pump's RETURN LINE CONNECTOR ASSEMBLY. Use two wrenches to loosen. See Figure 1.

1.1 Remove the RETURN LINE CONNECTOR ASSEMBLY from the GOVERNOR CONTROL COVER using care not to allow dirt to enter the injection pump. Remove and discard the RETURN LINE CONNECTOR O-RING. Set aside the RETURN LINE CONNECTOR for later installation on the new INTEGRATED ACTUATOR COVER ASSEMBLY.

1.2 Remove the ELECTRIC SHUTOFF (ESO) SOLENOID WIRE from the GOVERNOR CONTROL COVER. Trace the solenoid wire back to its source. Remove and discard the wire.

CAUTION

Do not use this wire to power the new INTEGRATED ACTUATOR.

1.3 Loosen the three COVER SCREWS and remove the GOVERNOR CONTROL COVER ASSEMBLY from the pump. Save all three screws for later installation of the INTEGRATED ACTUATOR COVER ASSEMBLY.



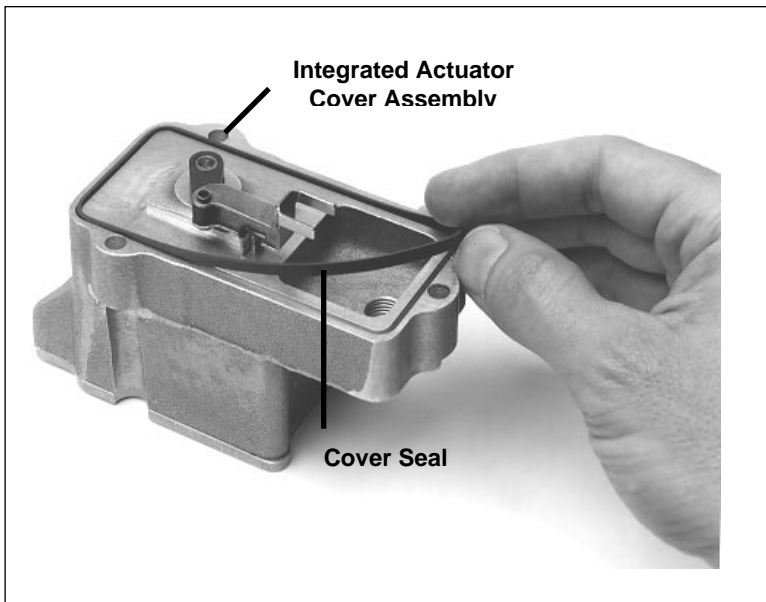

Figure 2

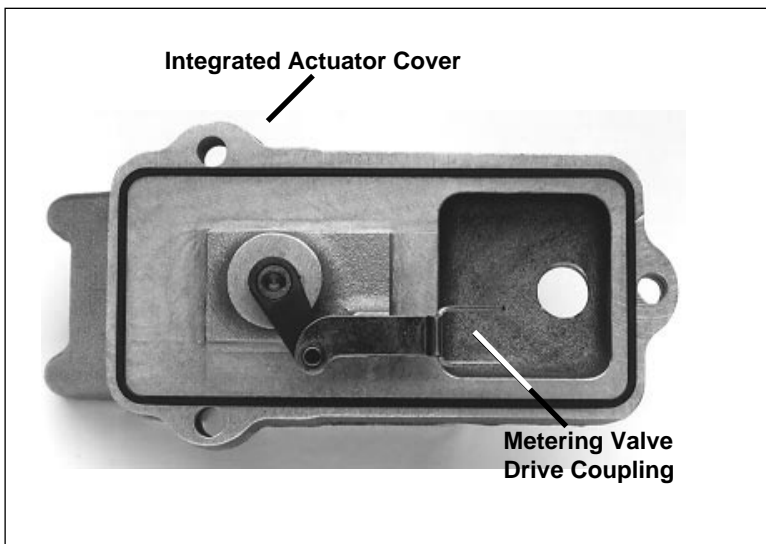

Figure 3

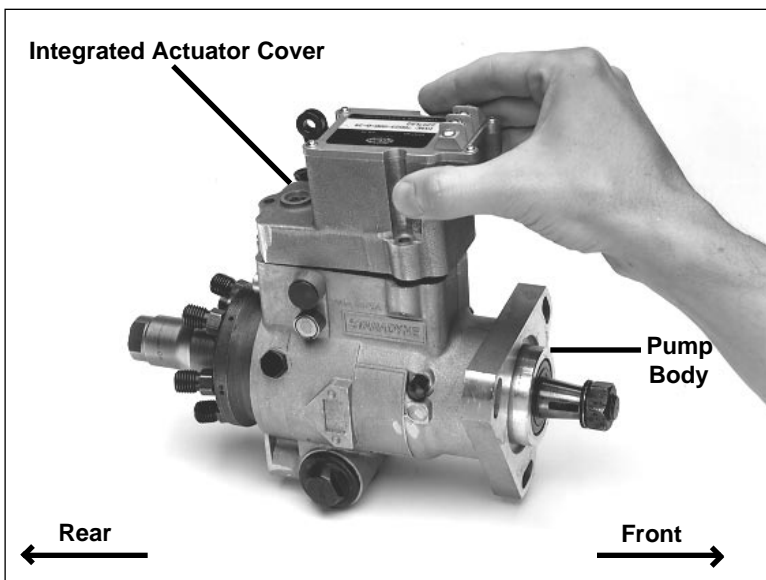

Figure 4

STEP 2

INSTALLING THE NEW INTEGRATED ACTUATOR COVER ASSEMBLY

2.0 Install new COVER SEAL — Item 2 from the parts list, into the groove of the INTEGRATED ACTUATOR COVER ASSEMBLY as shown in *Figure 2*.

2.1 Align and hold the METERING VALVE DRIVE COUPLING parallel to the side of the INTEGRATED ACTUATOR COVER as shown in *Figure 3*.

2.2 Position the INTEGRATED ACTUATOR COVER ASSEMBLY into the top of the pump while holding the METERING VALVE DRIVE COUPLING parallel to the PUMP BODY. Slightly lift the front portion of the INTEGRATED ACTUATOR COVER as shown in *Figure 4*.

2.3 Carefully slide the INTEGRATED ACTUATOR COVER toward the rear of the pump until the horseshoe portion of the METERING VALVE DRIVE COUPLING contacts the pump's GOVERNOR LINKAGE HOOK as shown in *Figure 5*. Once contact has been made, continue moving the INTEGRATED ACTUATOR COVER in the same direction until the mounting holes between the INTEGRATED ACTUATOR COVER and the PUMP BODY are aligned.

CAUTION

Failure to properly install the METERING VALVE DRIVE COUPLING to the pump's GOVERNOR LINKAGE can result in serious damage.

2.4 Obtain three COVER SCREWS retained from the original GOVERNOR CONTROL COVER. Assemble the INTEGRATED ACTUATOR COVER to the PUMP BODY with these screws. Tighten screws to 35 - 45 lbs/in.

2.5 Install a new O-RING — Item 3 from the parts list, on the RETURN LINE CONNECTOR ASSEMBLY retained from the original GOVERNOR CONTROL COVER. Apply a light coating of all purpose grease to the O-RING and install connector into the 7/16-20 UNF-2A threaded hole located in the INTEGRATED ACTUATOR COVER. Tighten to 43 - 53 lbs/in.

See **CAUTION** following on page 3.

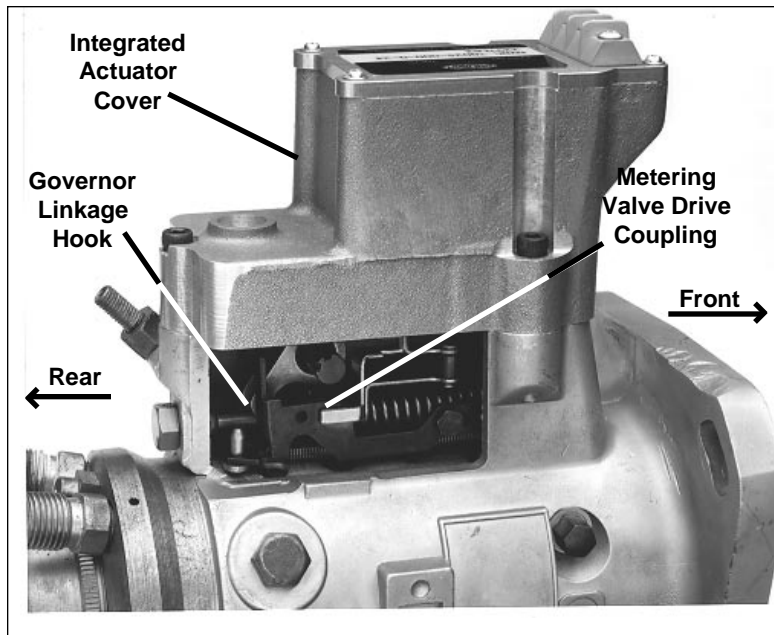

Figure 5

CAUTION

If the RETURN LINE CONNECTOR is a 7/16-20 UNF-2A, paragraph 2.5 can be completed. If the RETURN LINE CONNECTOR is not 7/16-20 UNF-2A, there are two possible solutions:

OPTION 1

A Stanadyne 21251 RETURN LINE CONNECTOR may be used to replace the RETURN LINE CONNECTOR ASSEMBLY on the return fuel line.

OPTION 2

A Stanadyne 24509 CONNECTOR BODY can be used to mate the 1/8-27 NPT RETURN LINE CONNECTOR ASSEMBLY to the 7/16-20 UNF-2A threaded hole located in the INTEGRATED ACTUATOR COVER.

2.6 Install the FUEL RETURN LINE to the RETURN LINE CONNECTOR. Hold RETURN LINE CONNECTOR in place and tighten FUEL RETURN LINE to engine manufacturer's specification.

STEP 3

PRELIMINARY SET-UP PROCEDURE

— NOTE —

The following method will be used to properly set up the mechanical governor for operation with the ELECTRONIC INTEGRATED ACTUATOR. Proper calibration of both the mechanical and electronic governor must be performed in order for the system to operate properly. Failure to perform this procedure properly may result in inability to provide maximum power or cause poor steady state speed control.

CAUTION

Steps 3.0 thru 3.3 are performed PRIOR to starting the engine.

3.0 Position the SHUT-OFF SHAFT ASSEMBLY (if equipped with one) in the "Fuel On" position by rotating it in the direction shown in Figure 6 until it reaches its limit of travel. Secure the SHUT-OFF SHAFT ASSEMBLY in place with existing mechanical linkage. A spring may be used to hold it in place when there is no linkage.

CAUTION

Do not attach springs to the engine's high pressure lines.

3.1 THROTTLE SHAFT ASSEMBLIES are often locked in the "High Idle" position on pumps equipped with speed droop governors. When this is the case, the LOW IDLE SCREW may be backed out a **maximum** of three (3) turns. This should only be done if the HIGH IDLE speed is known to be greater than 12% above the rated speed. Excessive backing out of the LOW IDLE SCREW may result in the disengagement of the pump's internal components.

— WARNING —

This procedure must be followed carefully in order to not overspeed the engine and cause damage to the generator or other load.

3.2 Adjust the droop by turning the DROOP ADJUSTING SCREW in a counterclockwise (CCW) direction until it stops. See Figure 6. Some pumps may not be equipped with a speed droop adjustment.

Turn the DROOP ADJUSTING SCREW clockwise (CW) two full turns. The mechanical governor is now set in a position that will permit starting the engine to calibrate the ELECTRONIC INTEGRATED ACTUATOR GOVERNOR. Do not operate the engine without the electronic governor connected and the system calibrated properly as described in Step 6.

Once this droop adjustment has been made, do not readjust.

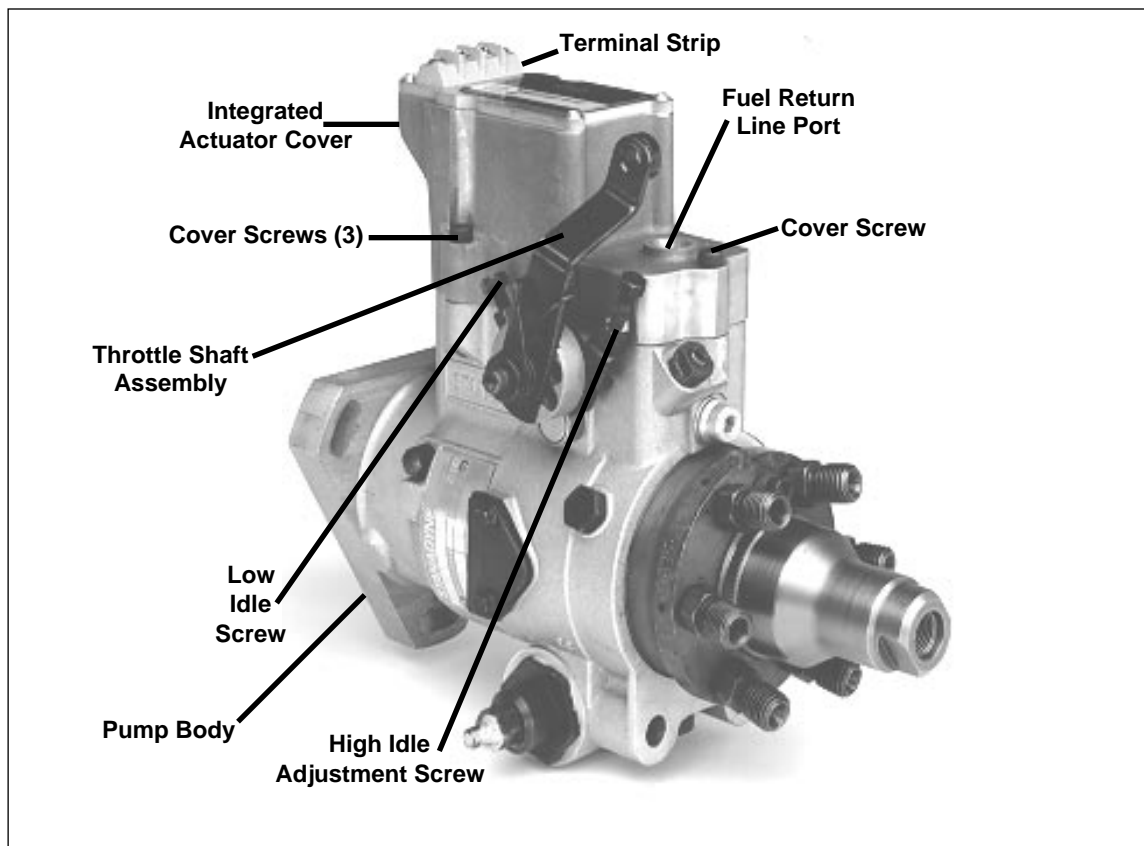

Figure 6

**STEP 4
MAGNETIC PICKUP INSTALLATION**

4.0 Refer to Bulletin Number 2, F-16457-1.

**STEP 5
GOVERNOR CONTROL BOX INSTALLATION**

CAUTION

Make certain that proper voltage (12 or 24 Vdc) GOVERNOR CONTROL BOX and INTEGRATED ACTUATOR ASSEMBLY are used.

5.0 Wire and pre-set the adjustments of the INTEGRATED GOVERNOR system as described in the wiring and calibration information for the controller's specific part number. Make certain to use the shielded wire and twisted cables as shown in the installation information.

Connect ACTUATOR WIRES to the two center terminals on the terminal strip. Do not connect any other wires to the actuator than the ones from the governor control box.

5.1 The mechanical governor is to be set 12% higher than the desired running speed. Calculate the maximum speed setting for the mechanical governor as follows:

EXAMPLE: If desired speed is 1800 RPM for electronic governing, then $1800 \times 0.12 = 216$ RPM; $1800 + 216 = 2016$ RPM.

**STEP 6
CALIBRATION PROCEDURE**

6.0 Make certain the electronic governor adjustments are set as stated in the proper governor literature.

The SPEED adjustment is a 20 turn potentiometer on the DYN1-10784 and DYN1-10794 control boxes. Turn it counterclockwise (CCW) 20 turns and then clockwise (CW) 5 turns.

6.1 Rotate and hold the THROTTLE SHAFT LEVER to maximum position as permitted by present high idle screw adjustment. Do not attempt at this time to adjust the high idle screw beyond its present setting.

6.2 Turn on the DC power to the system.

— NOTE —

Be sure Step 6.0 has been performed.

6.3 Start the engine. The engine should be operating on the INTEGRATED ACTUATOR COVER GOVERNOR. The speed should be below 1800 RPM or the desired speed.

— NOTE —

Check for fuel leaks.

6.4 Slowly using the GOVERNOR CONTROL BOX speed adjustment, increase the engine speed. (If the engine does not increase in speed, follow the troubleshooting procedure in the governor manual)

6.5 Keep increasing the speed until it is approximately 20 RPM higher than the speed calculated in Step 5.1. If this speed cannot be obtained, loosen the jam nut on the HIGH IDLE SPEED ADJUSTMENT SCREW of the THROTTLE LEVER and turn the HIGH IDLE ADJUSTMENT SCREW counterclockwise (CCW) until the calculated speed can be obtained. *See Figure 6.*

6.6 Set the speed with the electronic governor to the value calculated in Step 5.1. Then slowly turn the HIGH IDLE ADJUSTMENT SCREW on the THROTTLE LEVER clockwise (CW) until the speed just starts to decrease. Turn the HIGH IDLE ADJUSTMENT SCREW counterclockwise (CCW) until the speed just controls at the proper calculated speed. Tighten the HIGH IDLE adjusting screw locknut to 35-45 lbs/in.

6.7 Turn the LOW IDLE SCREW clockwise (CW) to lock the THROTTLE LEVER at this maximum position. Tighten the LOW IDLE adjustment screw locknut to 35-45 lbs/in.

— NOTE —

On some pump bodies, the LOW IDLE adjustment screw may not be able to position the throttle lever to the proper position. If it cannot hold the throttle to the proper position, use a spring to hold the throttle to the maximum position or maximum speed and power will not be obtainable.

CAUTION

Do not attach springs to the engine's high pressure lines.

6.8 Decrease the speed on the ELECTRONIC GOVERNOR CONTROL BOX until the desired run speed is obtained.

6.9 Properly calibrate the adjustments of the electronic governor.

Check the system for good response and stability at all possible loads and speeds.

STEP 7

SHUT OFF ENGINE

Parts List

Table 1: Governor Assembly
Specify voltage when ordering Items 1 and 4

Item	Description	Barber-Colman Part Number	Qty.
1	Integrated Actuator	DYNC-70025	1
2	Cover Seal	L5-162	1
3	O-Ring for Fuel Return	L5-163	1
4	Controller — See options below (Items 5 & 6)		

Table 2: Optional Control Components

Item	Description	Barber-Colman Part Number	Qty.
5	Controller — Analog without Remote Speed	DYN1-1078X	1
6	Controller — Analog with Remote Speed	DYN1-1079X	1
7	Magnetic Pickup — 3/8 In. Dia.	DYNT-17200	1
8	Remote Speed Potentiometer	DYNS-10000	1

"X" Specify operating frequency

Barber-Colman Company
Aerospace & Power Controls Division
DYNA Product Group

1354 Clifford Avenue Telephone (815) 637-3000
P.O. Box 2940 Facsimile (815) 877-0150
Loves Park, IL 61132-2940
United States of America

In Europe contact: Barber-Colman GmbH
Am Neuen Rheinhafen 4, D-67346 Speyer, Germany
Telephone 06232 1203, Facsimile 06232 12155, Telex 467 627

In Japan contact: Ranco Japan Ltd.
Shiozaki Bldg. 7-1, 2-chome, Hirakawa-Cho, Chiyoda-Ku
Tokyo 102, Japan
Telephone 3261 4293, Facsimile 3264 4691, Telex 0232 2087

CAUTION

As a safety measure, the engine should be equipped with an independent overspeed shutdown device in the event of failure which may render the governor inoperative.

NOTE

Barber-Colman believes that all information provided herein is correct and reliable and reserves the right to update at any time. Barber-Colman does not assume any responsibility for its use unless otherwise expressly undertaken.



CALIBRATION & WIRING FOR DYN1-10810 & DYN1-10840 CONTROLLERS

1.0 CALIBRATION PROCEDURE

- 1.1 Place SW1-1 in the "ADJUST 1" position.
- 1.2 Place SW1-2 to the desired generator frequency, 50 or 60 Hz.
- 1.3 Set SW1-3 to the correct number of engine cylinders.

— NOTE —

DYN1-10810 controller does not have SW1-3 switch.

- 1.4 SW2 is a rotary switch which rotates a continuous 360°, with "0" being MINIMUM and "F" being MAXIMUM GAIN. Set this switch at "4".
- 1.5 Place SW3-1 to the "P" position.
- 1.6 Place SW3-2 to the "I" position.
- 1.7 Place SW3-3 to the "D" position.

— CAUTION —

If SW1-3 is not set to the correct number of cylinders, overspeed may occur.

2.0 START THE ENGINE

- 2.1 With the engine running at the desired speed, slowly turn SW2 clockwise (CW) until the engine begins a quick audible hunt. Once the engine begins to hunt, turn SW2 counterclockwise (CCW) until stable. If the generator does not meet performance requirements, proceed through Step 3.

3.0 OPTIMIZE GOVERNOR PERFORMANCE

- 3.1 As in Step 2.1, turn SW2 clockwise (CW) until the engine begins to hunt.
 - 3.1.1 Once the engine begins to hunt, determine the frequency at which the actuator is oscillating. If the actuator is oscillating at a rate greater than 7 Hz (a fast hunt), change SW3-3 to the "D/2" position. If changing this position does not affect the hunt, reposition SW3-3 to "D" and proceed to step 3.1.2.
 - 3.1.2 If the actuator is oscillating at a rate between 3 to 6 Hz (a slower audible hunt), change SW3-1 to the "P/2" position. If the engine is now stable, proceed to step 3.1.3. If changing this position does not affect the hunt, reposition SW3-1 to the "P" position. Turn SW2 counterclockwise (CCW) until stable and proceed to step 3.3.
 - 3.1.3 With SW3 switches positioned, continue to turn SW2 clockwise until the engine begins to hunt. Once hunting, turn SW2 counterclockwise (CCW) until stable.
- 3.2 Shut off the engine. While watching a frequency meter, start the engine. If the overshoot is greater than the specified limit, change SW3-1 to the "ON" (1/2) position and repeat step 3.2 to ensure best performance.
- 3.3 If the governor does not meet the control specification, place SW1-1 on "ADJUST 2" position and repeat steps 2 through 3.2.

4.0 SPEED REFERENCE SIGNAL

Option I

Standard Coil Ignition — 1800 RPM

1. Jumper between terminals 5 & 6 must be in.
2. Terminal 6 should be connected to either tachometer output from coil or negative (-) terminal on coil. (Negative ignition pulse)

Wiring Diagrams — DYN1-10840

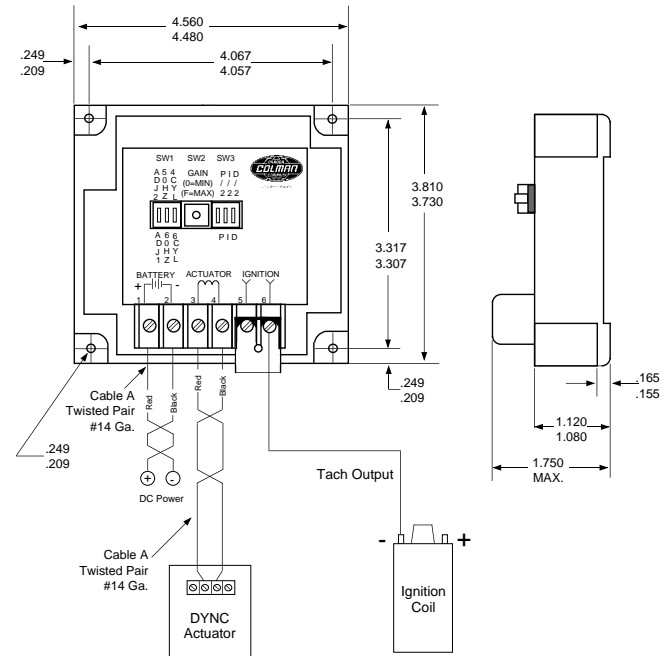

Option II

DIS (Distributorless) Ignition — 1800 RPM

1. Remove jumper between terminals 5 & 6.

— Note —

If jumper is not removed, the ignition module will be damaged.

2. Terminal 5 should be connected to one side of the DIS tachometer output and terminal 6 to the other output for tachometer.

— Note —

Ford 1.1 liter and 1.3 liter: Tachometer leads are yellow/black and yellow/white routed to coil. There should be connectors coming off of these leads. Terminals 5 & 6 would be connected to these connectors. (Not polarity sensitive)

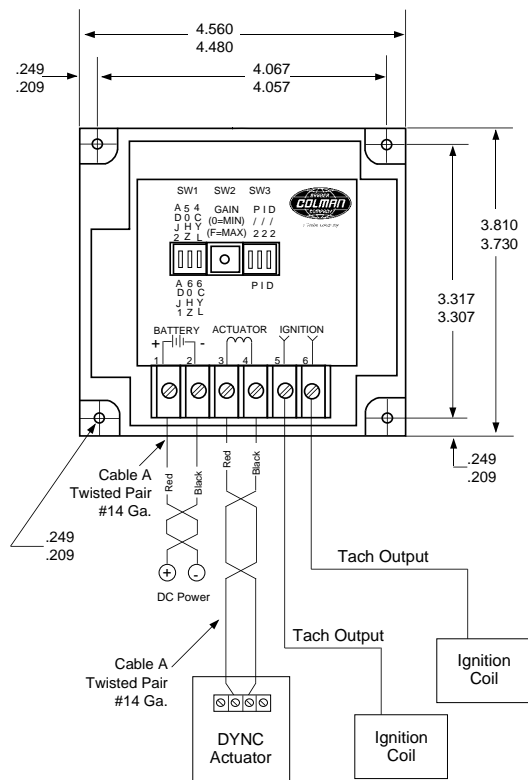

Option III

DIS (Distributorless) Ignition — 3600 RPM

1. Remove jumper between terminals 5 & 6.

— Note —

If jumper is not removed, the ignition module will be damaged.

2. Terminal 6 should be connected to one side of the DIS tachometer output and terminal 5 should be left open.

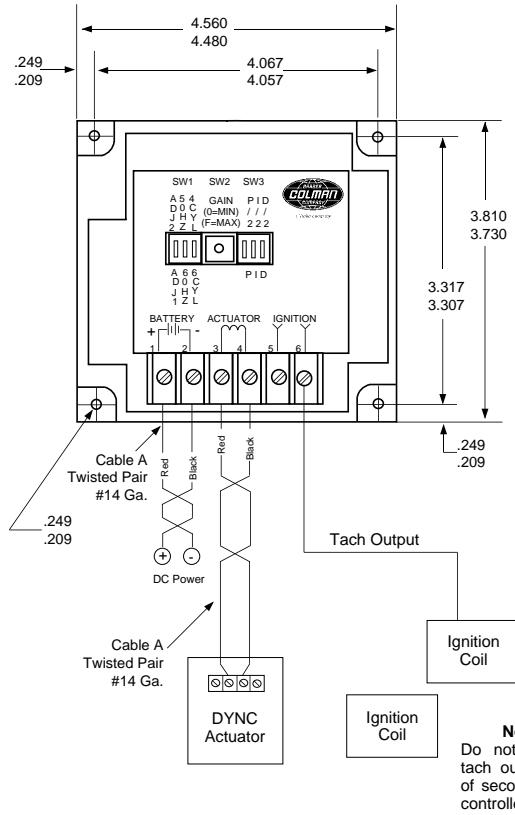

Wiring Diagram — DYN1-10810

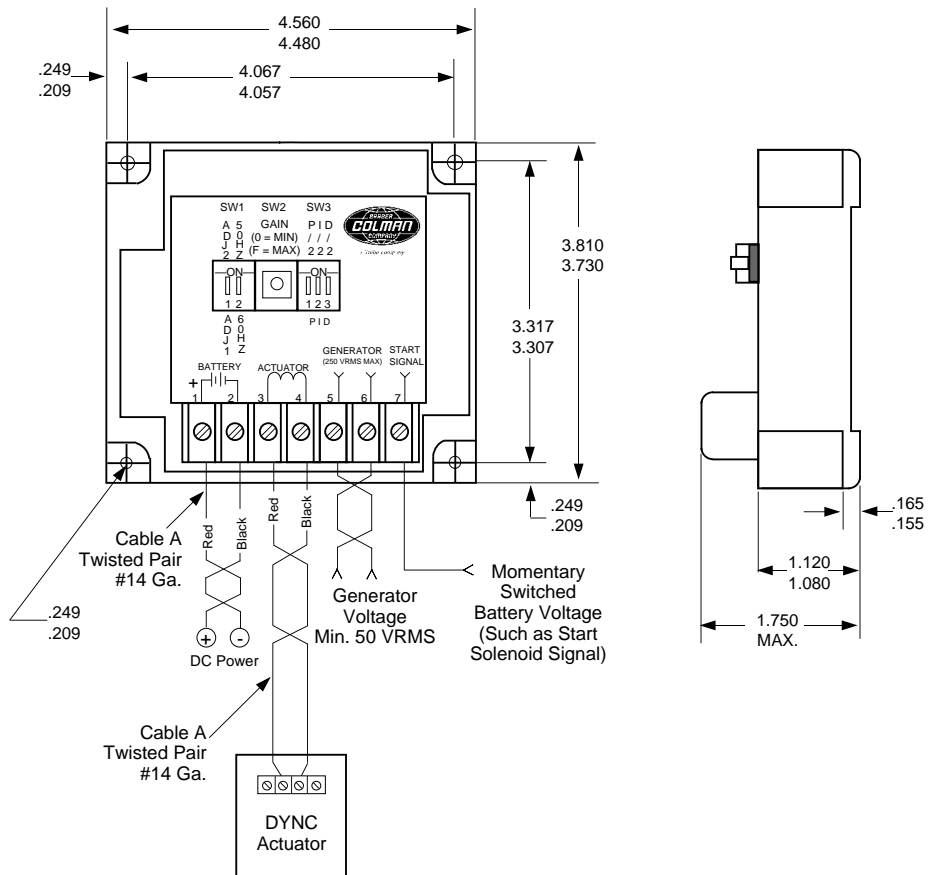

CAUTION

As a safety measure, the engine should be equipped with an independent overspeed shutdown device in the event of failure which may render the governor inoperative.

NOTE

Barber-Colman believes that all information provided herein is correct and reliable and reserves the right to update at any time. Barber-Colman does not assume any responsibility for its use unless otherwise expressly undertaken.

Barber-Colman Company
AEROSPACE & POWER CONTROLS DIVISION
DYNA Product Group

1354 Clifford Avenue
P.O. Box 2940
Loves Park, IL U.S.A. 61132-2940

Phone: (815) 637-3000
Fax: (815) 877-0150

In Europe contact: Barber-Colman GmbH
Am neuen Rheinhafen 4, D-6720 Speyer, West Germany
Tel: 06232-29903, Fax: 06232-299155

In Japan contact: Ranco Japan Ltd.
Shiozaki Bldg. 7-1, 2-chome, Hirakawa-Cho, Chiyoda-Ku
Tokyo 102, Japan
Tel: 3261-4293, Fax: 3264-4691



Troubleshooting Information for Stanadyne "D" Series Injection Pumps Equipped with Barber-Colman Integrated Actuator Assemblies

— Note —
See Section I for using test stand and Section II for testing cover only.

I. Checking out and Calibrating a New or Rebuilt Stanadyne Injection Pump, using an Injection Pump Test Stand.

In this situation, the Barber-Colman Integrated Actuator will be used like an energize-to-run solenoid for the Stanadyne injection pump and mechanical governor. The last two digits in the part number on the nameplate for the Barber-Colman Integrated actuator indicate the proper voltage to be used.

The voltage polarity to the two terminals on the cover does not matter. It is recommended that one of the two following methods be used to apply and remove the voltage to the actuator terminals.

The actuator is a coil with inductance. When applied voltage is suddenly removed, there is a large transient voltage at the actuator. When used in the complete Barber-Colman governing system, arc suppression is supplied in the electronic governor control box. This permits polarity free wiring from the governor control box to the actuator. For production test fixtures it would be wise to put a freewheeling diode on the terminal strip used to wire the power supply to the actuator connected with polarity as shown. Repeated transients could damage the dielectric characteristics of the actuator causing early failures. See Figure 1.

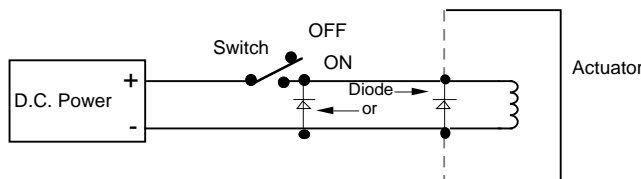

Figure 1

The diode, a Motorola MUR 810 or equivalent, could be used. It could be at the actuator terminal strip or at the switch.

Another method would be to slowly turn the DC voltage up and down.

As with the solenoid normally used, when the DC power is not applied to the actuator, the fuel is cut off from the engine. Use of the throttle lever and shut off lever have no effect.

When proper power is applied to the actuator, fuel is supplied to the engine as determined by the setting of the fuel shutoff lever and the combination of the throttle lever and input speed to the pump shaft. In this mode the throttle high and low speeds can be set as per the usual practice.

Checks to be made of the Integrated Actuator should be as follows:

1. Check the DC voltage shown on the integrated actuator cover for the specified DC voltage.
2. With all wires removed from the actuator terminals, use an ohmmeter to check for the proper resistance of the actuator coil. Measure between terminals of the terminal strip.

DC Voltage	Resistance in OHMS at normal room temp.
12 VDC	2.05 ± 0.25 OHMS
24 VDC	7.20 ± 0.50 OHMS

If easier, check the resistance of the coil by measuring current. The values would be as follows:

DC Voltage Of Unit	DC Voltage Applied	Current In Amps
12 VDC	12 ± 0.5 VDC	5.8 ± 0.5 Amps
24 VDC	24 ± 0.5 VDC	3.3 ± 0.4 Amps

3. With all wires removed, check the resistance between each of the two actuator terminals and case (ground). It must be 3 megohms or greater.
4. With the test stand operating on the mechanical governor, turn down the DC voltage to "0" and check that there is "0" fuel flow to the engine.



- If the test stand was not operating, energize and de-energize the actuator and listen for a “click”.

It should be noted that if the Integrated Actuator had considerable use and was worn or had been damaged to cause stickiness, the above testing probably would not detect the defect. This could only be done by operating the actuator on a computerized checkout system or an X-Y plotter using position or flow checkout with a feedback loop control.

II. Doing Basic Checkout of the Barber-Colman Integrated Actuator Cover when it has been removed from the Stanadyne Injection Pump

The Integrated Actuator Cover cannot be completely checked out unless performance checks are made. To do this requires a dedicated test fixture with a feedback control loop. This would check for stickiness and/or looseness detrimental for good governing performance.

Visual Checks (See Figure 2)

- Check or replace the Cover Seal.
- Check the terminal strip for breakage. If broken, unit must be returned to factory for repair.
- Check the internal wiring visually for frayed strands of wires at the terminal strip.
- Check that the actuator arm is tight to the actuator shaft, with no play.
- Check the pivot point of the actuator arm and metering valve drive coupling to see that it has free movement.

Electrical Checks

- Check the DC voltage shown on the integrated actuator cover for the specified DC voltage.
- Use an ohmmeter to check for the proper resistance of the actuator coil. Measure between terminals of the terminal strip.

<u>DC Voltage</u>	<u>Resistance in OHMS at normal room temp.</u>
12 VDC	2.05 ± 0.25 OHMS
24 VDC	7.20 ± 0.50 OHMS

If easier, check the resistance of the coil by measuring current. The values would be as follows:

<u>DC Voltage Of Unit</u>	<u>DC Voltage Applied</u>	<u>Current In Amps</u>
12 VDC	12 ± 0.5 VDC	5.8 ± 0.5 Amps
24 VDC	24 ± 0.5 VDC	3.3 ± 0.4 Amps

- Check the resistance between each of the two actuator terminals and case (ground). It must be three (3) megohms or greater.
- Take care that the actuator arm is free to travel and the metering valve drive coupling will not bind. Energize the actuator with the proper voltage and note that the lever arm moves to maximum mechanical position. Slowly de-energize the actuator (or use a diode as per Par. I, Figure 1) and determine that the lever arm returns to minimum position.

Figure 2

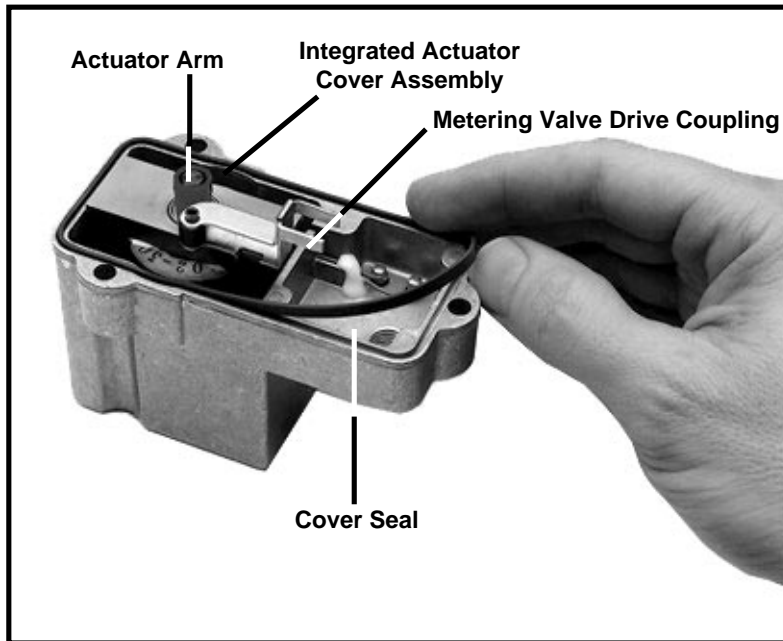

CAUTION
As a safety measure, the engine should be equipped with an independent overspeed shutdown device in the event of failure which may render the governor inoperative.

NOTE
Barber-Colman believes that all information provided herein is correct and reliable and reserves the right to update at any time. Barber-Colman does not assume any responsibility for its use unless otherwise expressly undertaken.

III. Troubleshooting an Engine Fueled by a Stanadyne Injection Pump Equipped with a Barber-Colman Integrated Actuator

1. PROBLEM: Engine does not crank over when start switch operated.

Means of Detection	Corrective Action
1.1 Check proper battery connections and voltage.	Repair, change or replace as required.
1.2 Check wiring to start switch and solenoid.	Repair or replace as required.
1.3 Check starter in accordance with engine manual.	Repair or replace as required.
1.4 Check tripped overspeed switch.	Re-set speed switch.

2. PROBLEM: Engine cranks but does not fire or start.

Means of Detection	Corrective Action
2.1 Check for fuel in tank.	Fill tank.
2.2 Carefully loosen nut at injector and crank engine, checking for fuel.	If fuel, check engine manual. If no fuel, proceed to Step 3.

3. PROBLEM: No fuel to injectors.

Means of Detection	Corrective Action
3.1 Loosen Return Fuel Line Connector and check for fuel while cranking.	If no fuel, check line to fuel pump and pressure supply, if any. If fuel, proceed to Step 4.

4. PROBLEM: No fuel to injectors, but fuel to pump.

Means of Detection	Corrective Action
4.1 While cranking engine, check for voltage at actuator terminals on fuel pump cover. Should be approximately 75% or greater of cranking voltage.	If have voltage, proceed to Step 5. If do not have voltage, proceed to Step 6.

5. PROBLEM: No fuel to injectors, have fuel to pump and have voltage to actuator terminals.

Means of Detection	Corrective Action
5.1 Place a low impedance 0-10 amp ammeter in one line to actuator. May need to check polarity first with voltmeter if polarized ammeter. Crank engine and check for 4.3 ± 1.5 amps for 12 VDC and 2.5 ± 1.3 amps for 24 VDC system.	If no current, internal wiring or coil open in cover assembly. Remove and replace. If shows proper current, check cover per Section II, or replace fuel pump assembly.

6. PROBLEM: No fuel to injectors, have fuel to pump and no voltage to actuator terminals.

Means of Detection	Corrective Action
6.1 Check for DC voltage at actuator output terminals of governor control box while cranking. Should be approximately 75% or greater of cranking voltage.	If have voltage, repair or replace wire from control box to actuator. If no voltage at actuator terminals while cranking, proceed to Step 7.

7. PROBLEM: No voltage at actuator terminal while cranking.

Means of Detection	Corrective Action
7.1 Check for proper DC supply voltage to governor control box while cranking.	If no voltage, check and repair wiring.
7.2 Check for 2.5 VAC minimum at magnetic pickup input terminal to governor control box while cranking.	If no voltage or low voltage, check or replace magnetic pickup and/or wiring. If voltage above 2.5 VAC, proceed to Step 8.

8. PROBLEM: DC voltage & magnetic pickup voltage are ok, but no voltage out actuator terminals when cranking.

Means of Detection	Corrective Action
8.1 Remove all wires but DC input power and magnetic pickup. While cranking engine slowly turn SPEED potentiometer on box clockwise (CW) at least ten (10) turns, checking for DC voltage at actuator terminals of control box with actuator leads disconnected. — WARNING — Turn SPEED potentiometer counterclockwise (CCW) ten (10) turns before connecting other wires and starting engine.	If no voltage, replace governor control box. If voltage present, check and correct wiring of disconnected wires.

9. PROBLEM: Engine runs but will not produce maximum power.

Means of Detection	Corrective Action
9.1 Check to determine that throttle shaft lever and/or shutoff lever are at proper position.	Shutoff lever must be at maximum position and throttle shaft lever 12% above maximum operating speed.
9.2 Check that DROOP is properly set.	Turn DROOP adjustment screw counterclockwise (CCW) until it stops. Turn the screw two full turns clockwise (CW).
9.3 Check that "L" pot is properly set on controller.	Note position of "L" pot. Turn slowly clockwise (CW) to increase current to actuator. If engine still does not produce full power, return "L" pot to original position.

10. PROBLEM: Engine speed erratic at high loads.

Means of Detection	Corrective Action
10.1 Make certain throttle shaft lever and DROOP are properly set.	Set per Step 9 above.

11. PROBLEM: Engine speed surges, jitters or operates erratically at all or some speeds and loads.

Means of Detection	Corrective Action
11.1 Refer to calibration and troubleshooting for the appropriate controller.	Follow procedure.

**Barber-Colman Company
Aerospace & Power Controls Division
DYNA Product Group**

1354 Clifford Avenue Telephone (815) 637-3000
P.O. Box 2940 Facsimile (815) 877-0150
Loves Park, IL 61132-2940
United States of America

In Europe contact: Barber-Colman GmbH
Am Neuen Rheinhafen 4, D-67346 Speyer, Germany
Telephone 06232 29903, Facsimile 06232 299155

In Japan contact: Ranco Japan Ltd.
Shiozaki Bldg. 7-1, 2-chome, Hirakawa-Cho, Chiyoda-Ku
Tokyo 102, Japan
Telephone 3261 4293, Facsimile 3264 4691



Calibration Procedure - DYN1 1078X Controllers For Stanadyne Pumps Using DYNC-70025 Integrated Actuator

Part Number	Input Signal Frequency Maximum
DYN1-10784-000-0-12/24	2500 to 5000 Hz
DYN1-10784-001-0-12/24*	
DYN1-10786-000-0-12/24	5000 to 9500 Hz
DYN1-10786-001-0-12/24*	

* CE

1.0 Calibration Procedure

1.1 With no power to the governor, adjust the GAIN to 9:00.

1.2 Start the engine and adjust the speed by turning the SPEED potentiometer clockwise (CW) to desired speed.

— NOTE —

Controllers are factory adjusted to minimum RPM. However, for safety, the engine should be capable of being disabled if an overspeed should exist.

1.3 At no load, turn the GAIN potentiometer clockwise (CW) until the engine begins to hunt. If the engine does not hunt, momentarily disrupt the governor power supply.

1.4 Turn the GAIN potentiometer counterclockwise (CCW) until stable. For optimum performance, the engine should oscillate 3 to 5 diminishing cycles.

2.0 Wiring

2.1 Non CE conformed controllers are wired as shown in Wiring Diagram, *Figure 1*.

1. Red to battery positive.
2. Black to battery negative.
3. White to one side of the magnetic pickup.
4. Black and white to the other side of the magnetic pickup, connected with the shield drain wire.
5. Purple to the actuator with no designated polarity.

2.2 Controllers with CE conformity are wired as shown in Wiring Diagram, *Figure 2*.

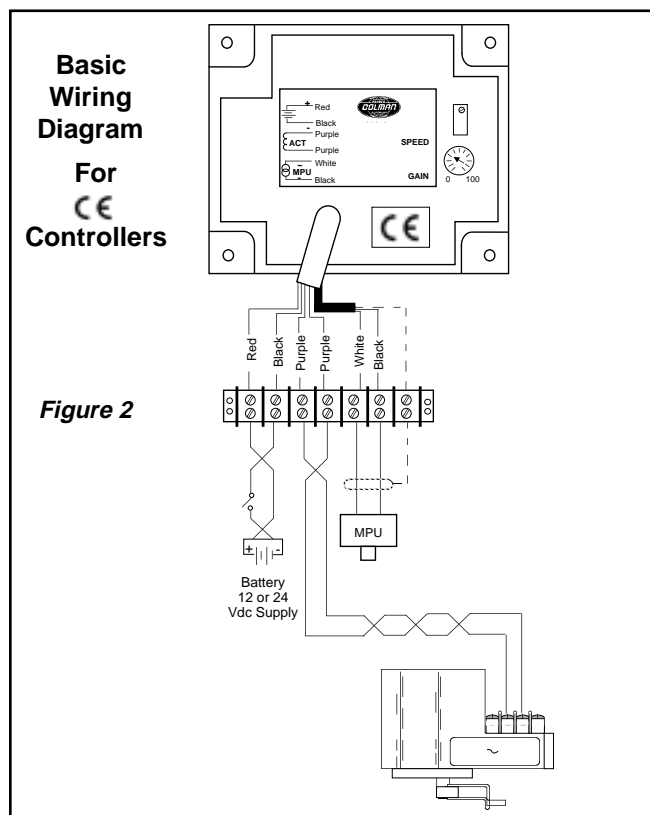
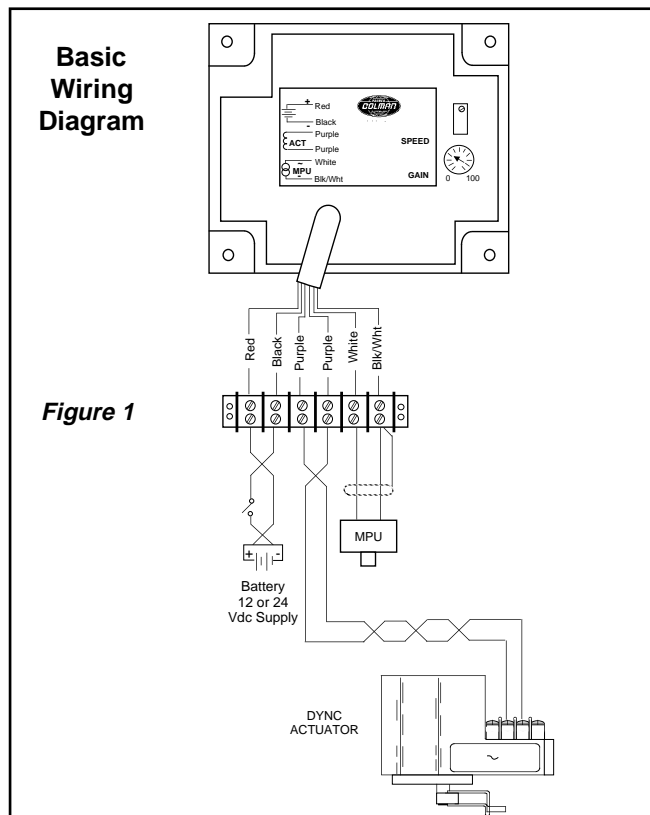

3.0 Troubleshooting Chart

Problem	Detection	Corrective Action
<p>I. System appears dead.</p>	<p>1. CHECK BATTERY VOLTAGE AT CONTROLLER with power switch "ON". Measure DC battery voltage between the Red (+) and Black (-) leads. Battery voltage should be present.</p>	<p>Check connections to battery.</p>
	<p>2. NO SIGNAL OR WEAK SIGNAL FROM MAGNETIC PICKUP. Measure AC voltage between the White and Black/White leads on controller while cranking engine. Voltage should be 2.5 volts RMS or greater. (AC input impedance of meter must be 5000 ohms/volt or greater.)</p>	<p>Check for damage to or improper adjustment of magnetic pickup. Replace or re-adjust.</p>
	<p>3. CHECK ACTUATOR with power "ON" to controller. Measure following terminals on control box with actuator wires connected. All points should read BATTERY VOLTAGE. (+0.00/-0.75 VDC)</p> <p>a. Purple lead to Black lead on controller.</p> <p>b. Second Purple lead to Black lead on controller. (Continue this test only if battery voltage is not present.)</p> <p>c. Following checks are terminals on the actuator and the Black lead on controller.</p> <p>1) Low voltage (1.0-2.0 VDC) at either actuator connector.</p> <p>2) Battery voltage at both actuator connectors.</p> <p>3) Battery voltage at one actuator lead but not at the other.</p>	<p>Replace controller if battery voltage is not present at both Purple leads.</p> <p>Check actuator leads for continuity. Repair or replace if needed.</p> <p>Replace actuator.</p>
<p>II. Actuator hunts during operation.</p>	<p>1. Improper governor adjustment.</p>	<p>Readjust calibration.</p>
	<p>2. Inadequate power supply voltage.</p> <p>a. Turn power switch "OFF".</p> <p>b. Connect a DC voltmeter to Red and Black leads at control box.</p> <p>c. Disconnect both leads to actuator at Purple leads of control box.</p> <p>d. Connect one actuator lead to the Red lead and one actuator lead to the Black lead of the control box.</p> <p>e. Momentarily turn "ON" the DC power. The actuator should go to full fuel and the DC voltage must be greater than 80% of supply.</p> <p>24 VDC @ 80% = 19.2 VDC 12 VDC @ 80% = 9.6 VDC</p> <p>Note: Reconnect actuator leads properly after completing this test.</p>	<p>If actuator doesn't get to full fuel, then check actuator leads. If voltage is less than specified, check for loose or poor connections to battery, or get larger supply leads or larger power supply.</p>

Barber-Colman DYNA Products

1354 Clifford Avenue Telephone +1 815 637-3000
P.O. Box 2940 Facsimile +1 815 877-0150
Loves Park, IL 61132-2940 www.dynaproducts.com
United States of America

In Europe contact: Barber-Colman GmbH
Am Neuen Rheinhafen 4, D-67346 Speyer, Germany
Telephone (49) 6232 29903, Facsimile (49) 6232 299155

In Japan contact: Ranco Japan Ltd.
Shiozaki Bldg. 7-1, 2-chome, Hirakawa-Cho, Chiyoda-Ku
Tokyo 102, Japan
Telephone (81) 3 3261 4293, Facsimile (81) 3 3264 4691

An Invensys company

NOTE

Barber-Colman believes that all information provided herein is correct and reliable and reserves the right to update at any time. Barber-Colman does not assume any responsibility for its use unless otherwise expressly undertaken.

CAUTION

As a safety measure, the engine should be equipped with an independent overspeed shutdown device in the event of failure which may render the governor inoperative.



TECHNICAL MANUAL FOR DYNA 8000, 8200 & 8400 ELECTRONIC GOVERNOR



DYNA 8000



DYNA 8200



DYNA 8400



DYNA 8000-400 & DYNA 8400-400

CONTENTS

<u>SECTION</u>	<u>DESCRIPTION</u>	<u>PAGE</u>
1	GENERAL INFORMATION	3
2	SPECIFICATIONS.....	3
3	FUNCTIONAL DESCRIPTION	5
4	INSTALLATION.....	6
5	CALIBRATION OF DYN1-1065X.....	9
6	CALIBRATION OF DYN1-1068X.....	11
7	TROUBLESHOOTING	13
8	INSTALLATION DIMENSIONS	15

1. GENERAL INFORMATION

1.1 INTRODUCTION

The DYNA 8000, DYNA 8200 and DYNA 8400 governor system provides an engine governor for speed and power control of piston and gas turbine engines or steam and water turbines.

The actuator is a simple, proportional, electric solenoid having a sliding armature whose magnetic force is proportional to input coil current. The armature glides on anti-friction bearings and is balanced between the force of its return spring and the magnetic force, thus providing a hysteresis-free linear movement. The linear motion is converted to an output shaft rotation by a crank arm.

The hazardous duty DYNA 8000 and DYNA 8400 actuators provide units that are UL listed for Class I, Division 2, Group D, hazardous duty applications that are often encountered in the petroleum or chemical industries. The hazardous duty actuators can be used to provide an engine governor for speed and power control of piston and gas turbine engines.

1.2 TYPICAL APPLICATIONS

Typical applications are speed governing, remote throttle control, generator sets, power carts and pump set applications.

1.3 STANDARD FEATURES

- All electric
- All engine compatible
- Mounts in any position
- Engine mounted (actuator only)
- High reliability due to few moving parts
- Proportional actuator
- No hydraulic or oil lines
- No special maintenance
- Spring returns output shaft to minimum position on removal of power or loss of magnetic pickup signal
- Precise repeatability

2. SPECIFICATIONS

2.1 CONTROLLER SPECIFICATIONS

2.1.1 Operating Voltage: 12 VDC or 24 VDC ±20%

2.1.2 Ambient Operating Temperature:

-40 to +180°F (-40 to +85°C).

2.1.3 Temperature Stability: Better than ±0.5% over a temperature range of -40 to +167°F (-40 to +75°C).

2.1.4 Steady State Speed Band: ±0.25%

2.1.5 Adjustments: Speed, Gain, Integral, and Droop.

2.1.6 Circuit Boards: Boards are covered with a heavy conformal coating for moisture and vibration protection.

2.1.7 Connection: Terminal strip.

2.1.8 Mechanical Vibration: Withstands the following vibration without failure or degraded performance: 0.06 inch double amplitude at 5 to 18 Hz; 1 G at 18 to 30 Hz; 0.02 inch double amplitude at 30 to 48 Hz; 2.5 G's at 48 to 70 Hz.

2.1.9 The same DYN1-1065X or DYN1-1068X Series can be used on a DYNA 8000, DYNA 8200 or DYNA 8400 actuator. The DYN1-1068X governor control box provides a wider range of adjustment than the DYN1-1065X. The DYN1-1068X can be used where maximum performance is desired or for some engines which are possibly more difficult to control.

2.1.10 DYNA 8000 CONTROLLER

Output Current @ 12 VDC	Nominal Quiescent Current	80 mA
	Maximum Amperes @ Stall	13 amps
Output Current @ 24 VDC	Nominal Quiescent Current	80 mA
	Maximum Amperes @ Stall	13 amps
Weight	Kilograms	0.863
	Pounds	1.9

2.1.11 DYNA 8000 CONTROLLER

INPUT SIGNAL FREQUENCY

$$\text{Input Signal Frequency in Hertz} = \frac{\text{Engine RPM} \times \text{Number of Gear Teeth on Flywheel}}{60 \text{ Seconds}}$$

Select controller for the correct input signal frequency range generated by the magnetic pickup at the maximum engine operated (RPM) speed.

2.1.12 AVAILABLE CONTROLLER MODELS

Controllers: Speed Input Signal Frequency

- DYN1-10652-000-0-12/24 250 - 1200 Hz
- DYN1-10653-000-0-12/24 1200 - 2500 Hz
- DYN1-10654-000-0-12/24 2500 - 5000 Hz
- DYN1-10656-000-0-12/24 5000 - 9500 Hz
- DYN1-10682-000-0-12/24 250 - 1200 Hz
- DYN1-10683-000-0-12/24 1200 - 2500 Hz
- DYN1-10684-000-0-12/24 2500 - 5000 Hz
- DYN1-10686-000-0-12/24 5000 - 9500 Hz

2.2. DYNA 8000 & DYNA 8000 UL APPROVAL, HAZARDOUS DUTY, CLASS 1, DIVISION 2, GROUP D ACTUATOR SPECIFICATIONS

2.2.1 Operating Voltage: 12 VDC or 25 VDC ±20%

2.2.2 Ambient Operating Temperature:

-65 to +255°F (-55 to +125°C).

2.2.3 Sealed Unit: Oil, water and dust tight.

2.2.4 Connection: Terminal strip or "MS" Connector.

2.2.5 Mechanical Vibration: 5 to 500 Hz, Curve F, per MIL-STD. 810D, Method 514-2.

2.2.6 DYNA 8000 ACTUATORS

Work	Joules	1.2
	Foot-Pounds	0.9
Torque	Newton-Meters	1.4
	Pound-Foot	1.0
Output	Rotary	35°
Weight	Kilograms	5
	Pounds	11.0
Current @ 12 VDC	Maximum Amperes @ Stall	12.5
	Nominal Steady State Amperes	3.5
Current @ 24 VDC	Maximum Amperes @ Stall	9.5
	Nominal Steady State Amperes	1.5
Nominal Response Time for 63% of Stroke (Seconds)		0.030

2.2.7 AVAILABLE DYNA 8000 ACTUATOR MODELS WITH CLOCKWISE OUTPUT SHAFT ROTATION (Standard Mounted Units)

- DYNC-11020-000-0-12 Standard Clockwise
DYNC-11020-000-0-24 Output Shaft Rotation
- DYNC-11021-000-0-12 Actuator Head Positioned 180°
DYNC-11021-000-0-24 from Standard DYNC-11020
- DYNC-11022-000-0-12 Actuator Head Positioned 90°
DYNC-11022-000-0-24 CCW from Standard DYNC-11020
- DYNC-11023-000-0-12 Actuator Head Positioned 90°
DYNC-11023-000-0-24 CW from Standard DYNC-11020

2.2.8 AVAILABLE DYNA 8000 ACTUATOR MODELS WITH CLOCKWISE OUTPUT SHAFT ROTATION (Side Mounted Units)

- DYNC-11020-300-0-12 Standard Clockwise
DYNC-11020-300-0-24 Output Shaft Rotation
- DYNC-11021-300-0-12 Actuator Head Positioned 180°
DYNC-11021-300-0-24 from Standard DYNC-11020
- DYNC-11022-300-0-12 Actuator Head Positioned 90°
DYNC-11022-300-0-24 CCW from Standard DYNC-11020
- DYNC-11023-300-0-12 Actuator Head Positioned 90°
DYNC-11023-300-0-24 CW from Standard DYNC-11020

2.2.9 AVAILABLE DYNA 8000 ACTUATOR MODELS WITH COUNTERCLOCKWISE OUTPUT SHAFT ROTATION (Standard Mounted Units)

- DYNC-11024-000-0-12 Standard Clockwise
DYNC-11024-000-0-24 Output Shaft Rotation
- DYNC-11025-000-0-12 Actuator Head Positioned 90°
DYNC-11025-000-0-24 CW from Standard DYNC-11024
- DYNC-11026-000-0-12 Actuator Head Positioned 180°
DYNC-11026-000-0-24 CCW from Standard DYNC-11024
- DYNC-11028-000-0-12 Actuator Head Positioned 90°
DYNC-11028-000-0-24 CCW from Standard DYNC-11024

2.2.10 AVAILABLE DYNA 8000 ACTUATOR MODELS WITH COUNTERCLOCKWISE OUTPUT SHAFT ROTATION (Side Mounted Units)

- DYNC-11024-300-0-12 Standard Clockwise
DYNC-11024-300-0-24 Output Shaft Rotation
- DYNC-11025-300-0-12 Actuator Head Positioned 90°
DYNC-11025-300-0-24 CW from Standard DYNC-11024
- DYNC-11026-300-0-12 Actuator Head Positioned 180°
DYNC-11026-300-0-24 CCW from Standard DYNC-11024
- DYNC-11028-300-0-12 Actuator Head Positioned 90°
DYNC-11028-300-0-24 CCW from Standard DYNC-11024

2.2.11 AVAILABLE DYNA 8000 HAZARDOUS DUTY ACTUATOR MODELS WITH CLOCKWISE OUTPUT SHAFT ROTATION (Standard Mounted Units)

- DYNC-11020-400-0-12 Standard Clockwise
DYNC-11020-400-0-24 Output Shaft Rotation
- DYNC-11021-400-0-12 Actuator Head Positioned 180°
DYNC-11021-400-0-24 from Standard DYNC-11020
- DYNC-11022-400-0-12 Actuator Head Positioned 90°
DYNC-11022-400-0-24 CCW from Standard DYNC-11020

2.2.12 AVAILABLE DYNA 8000 HAZARDOUS DUTY ACTUATOR MODELS WITH COUNTERCLOCKWISE OUTPUT SHAFT ROTATION (Standard Mounted Units)

- DYNC-11024-400-0-12 Standard Clockwise
DYNC-11024-400-0-24 Output Shaft Rotation
- DYNC-11025-400-0-12 Actuator Head Positioned 90°
DYNC-11025-400-0-24 CW from Standard DYNC-11024
- DYNC-11026-400-0-12 Actuator Head Positioned 180°
DYNC-11026-400-0-24 CCW from Standard DYNC-11024

2.2.13 AVAILABLE DYNA 8000 HAZARDOUS DUTY ACTUATOR MODELS WITH CLOCKWISE OUTPUT SHAFT ROTATION (Side Mounted Units)

- DYNC-11020-401-0-12 Standard Clockwise
DYNC-11020-401-0-24 Output Shaft Rotation
- DYNC-11021-401-0-12 Actuator Head Positioned 180°
DYNC-11021-401-0-24 from Standard DYNC-11020
- DYNC-11022-401-0-12 Actuator Head Positioned 90°
DYNC-11022-401-0-24 CCW from Standard DYNC-11020

2.2.14 AVAILABLE DYNA 8000 HAZARDOUS DUTY ACTUATOR MODELS WITH COUNTERCLOCKWISE OUTPUT SHAFT ROTATION (Side Mounted Units)

- DYNC-11024-401-0-12 Standard Clockwise
DYNC-11024-401-0-24 Output Shaft Rotation
- DYNC-11025-401-0-12 Actuator Head Positioned 90°
DYNC-11025-401-0-24 CW from Standard DYNC-11024
- DYNC-11026-401-0-12 Actuator Head Positioned 180°
DYNC-11026-401-0-24 CCW from Standard DYNC-11024

2.3 DYNA 8200 ACTUATORS

2.3.1 Operating Voltage: 12 or 24 VDC \pm 20%.

2.3.2 Ambient Operating Temperature: -65 to +255F (-55 to +125°C).

2.3.3 Sealed Unit: Oil, water and dust tight.

2.3.4 Connection: Terminal strip or "MS Connector.

2.3.5 Mechanical Vibration: 5 to 500 Hz, Curve F, per MIL-STD. 810D, Method 514-2.

Work	Joules	2.85
	Foot-Pounds	2.10
Torque	Newton-Meters	4.07
	Pound-Foot	3.00
Output	Rotary	45°
Weight	Kilograms	8.4
	Pounds	18.5
Current @ 12 VDC	Maximum Amperes @ Stall	14.75
	Nominal Steady State Amperes	4.5
Current @ 24 VDC	Maximum Amperes @ Stall	14.0
	Nominal Steady State Amperes	3.5
Nominal Response Time for 63% of Stroke (Seconds)		.138

2.3.6 AVAILABLE DYNA 8200 ACTUATOR MODELS WITH CLOCKWISE OUTPUT SHAFT ROTATION

- DYNC-12000-000-0-12 Standard Clockwise
DYNC-12000-000-0-24 Output Shaft Rotation
- DYNC-12001-000-0-12 Actuator Head Positioned 180°
DYNC-12001-000-0-24 from Standard DYNC-12000
- DYNC-12002-000-0-12 Actuator Head Positioned 90°
DYNC-12002-000-0-24 CCW from Standard DYNC-12000
- DYNC-12003-000-0-12 Actuator Head Positioned 90°
DYNC-12003-000-0-24 CW from Standard DYNC-12000

2.4 DYNA 8400 & DYNA 8400 UL APPROVAL, HAZARDOUS DUTY, CLASS 1, DIVISION 2, GROUP D ACTUATOR SPECIFICATIONS

2.4.1 Operating Voltage: 24 VDC ±20%.

2.4.2 Ambient Operating Temperature:
-65 to +255F (-55 to +125°C).

2.4.3 Sealed Unit: Oil, water and dust tight.

2.4.4 Connection: Terminal strip or "MS Connector.

2.4.5 Mechanical Vibration: 5 to 500 Hz, Curve F, per MIL-STD. 810D, Method 514-2.

2.4.6 DYNA 8400 ACTUATORS

Work	Joules	5.8
	Foot-Pounds	4.3
Torque	Newton-Meters	7.3
	Pound-Foot	5.4
Output	Rotary	45°
Weight	Kilograms	12.2
	Pounds	27
Current @ 24 VDC	Maximum Amperes @ Stall	13
	Nominal Steady State Amperes	2.0
Nominal Response Time for 63% of Stroke (Seconds)		0.104

2.4.7 AVAILABLE DYNA 8400 ACTUATOR MODELS WITH TERMINAL STRIP CONNECTION

- DYNC-14800-000-0-24 Through Output Shaft Making Available CW and CCW Output

2.4.8 AVAILABLE DYNA 8400 ACTUATOR MODELS WITH 2-PIN MS SCREW ON CONNECTOR

- DYNC-14801-000-0-24 Through Output Shaft Making Available CW and CCW Output

2.4.9 AVAILABLE DYNA 8400 HAZARDOUS DUTY ACTUATOR WITH TERMINAL STRIP CONNECTION INSIDE CAST IRON JUNCTION BOX

- DYNC-14800-400-0-24 Through Output Shaft Making Available CW and CCW Output

3. FUNCTIONAL DESCRIPTION

3.1 ACTUATOR

The actuator consists of an electro-magnet with an iron armature rolling on the center shaft bearings. The actuator is provided with a return spring which balances the magnetic force of the armature. When DC current flows in the coil, the magnetic force tends to move the armature in the stator and this linear motion is transformed into rotary motion through a crank arm that forms part of the output shaft.

3.2 CONTROLLER

The electronic controller is the information processing unit of the governor assembly. It contains electronic components which process the input signal from the magnetic pickup and control the engine to the desired speed/RPM set into the controller. Electronic adjustments are available on the controller for field adjusting the unit as necessary.

3.3 DC POWER SOURCE

The governor system receives its power from a battery or an AC to DC power supply supplying 12 or 24 VDC ±20% to match the governor voltage. The average operating current consumption is 2.5 to 3.5 amperes and the highest consumption is 14.75 amperes during engine start-up or during a large load change. The power source must be rated above maximum stall current.

3.4 COMPONENT LOCATION

The actuator of the governor assembly is mounted on the engine next to the fuel system. The magnetic pickup is normally mounted in the flywheel housing in such a way that it can count the teeth on the starter ring gear. The controller is off-mounted or installed in the engine control panel or cabinet.

3.5 ISOCHRONOUS OPERATION

Isochronous operation is obtained by setting droop potentiometer fully counterclockwise. The DYNA governor is all electric, and it is normally operated in the isochronous mode; i.e., engine RPM is constant ($\pm 0.25\%$) under steady state load conditions, up to the engine's maximum capability, regardless of load on the engine.

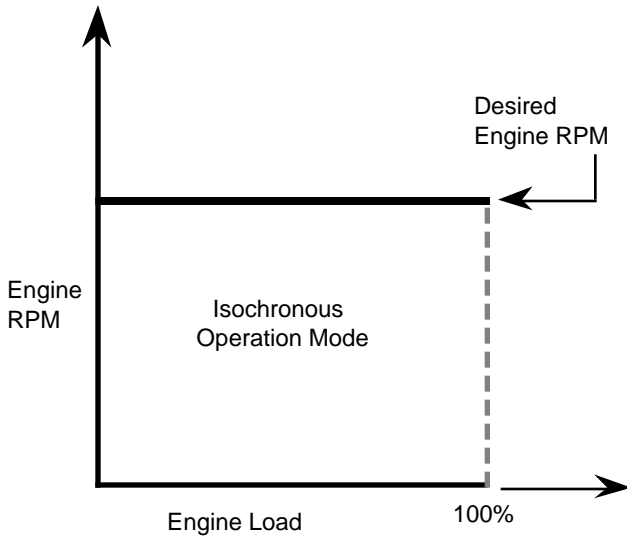

3.6 DROOP OPERATION

Droop operation is obtained by setting the droop potentiometer. Clockwise increases the droop. The amount of droop for a given setting depends on the magnetic pickup frequency and no load to full load actuator shaft rotation. A droop potentiometer setting of 10 o'clock will give about 4% droop, no load to full load when the pickup frequency is 4260 Hz and actuator shaft rotation is approximately 30 degrees from no load to full load. Lower pickup frequency or smaller shaft rotation results in less droop for the system.

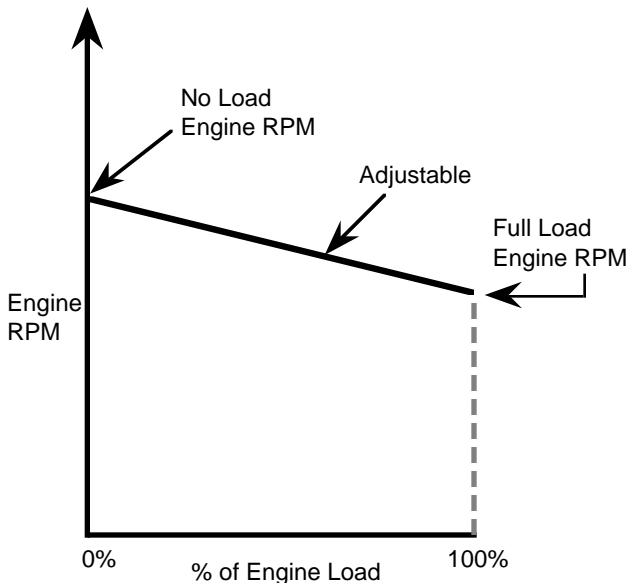

3.7 REMOTE SPEED ADJUSTMENT

An optional remote speed selector (DYNS-10000) is available for adjusting engine RPM from up to 90 meters (300 ft.) from the engine. See the Electrical Wiring Schematic. The potentiometer can be connected for a narrow (fine) or wide speed range control.

4. INSTALLATION

4.1 PROCEDURE

4.1.1 Mount the actuator on a suitable rigid steel bracket or plate.

NOTE

Mounting information and kits are usually available for a particular engine. Contact Sales Representative.

4.1.2 Set up the linkage and rod end bearings (see 4.2).

4.1.3 Install the speed sensor with SAE threads (magnetic pickup)*.

*Magnetic pickups with metric threads are available.
Thread — M16 x 1.5 — 6 g. Tap Drill Size — 14.5 ϕ mm.

4.1.3.1 Remove the inspection cover over the ring gear teeth. The teeth should be free of burrs, excessive grease or dirt.

4.1.3.2 The magnetic pickup should not be installed in inspection covers. Inspect the ring gear housing and pick a location where a 37/64" hole can be drilled such that the ring gear teeth will pass in front of the pickup pole face. After the 37/64" hole is drilled, use a 5/8-18 starting tap to cut threads for the magnetic pickup, then run a bottom tap through the hole.

NOTE

The tapped hole should be drilled as nearly perpendicular as possible over the center of the ring gear teeth.

4.1.3.3 Manually rotate the ring gear until a tooth face is directly in the center of the tapped hole. Gently turn the magnetic pickup clockwise into the hole until it bottoms on the tooth, and back off 1/4 turn. Tighten the jam nut firmly, maintaining the 1/4 turn position.

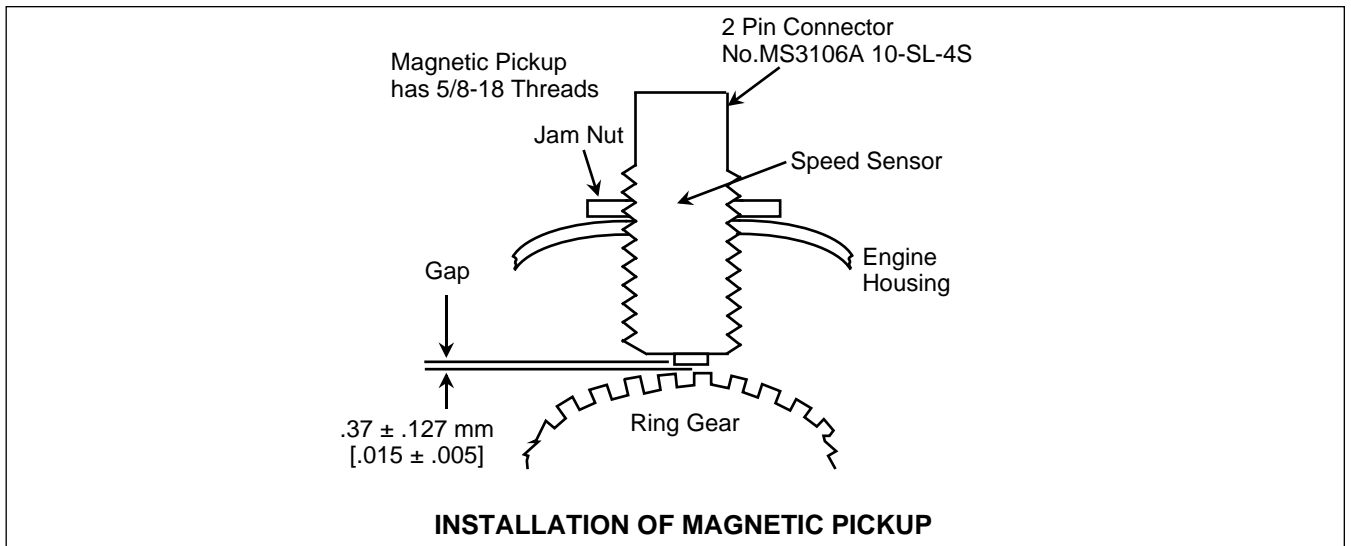

4.1.4 Mount the controller in the control panel.

4.1.5 Connect the wiring as shown in section 4.3 or according to your particular wiring diagram.

4.2 TYPICAL LINKAGE ARRANGEMENTS FOR THE ACTUATOR AND FUEL SYSTEM

4.2.1 ROTARY ACTUATOR TO ROTARY FUEL PUMP

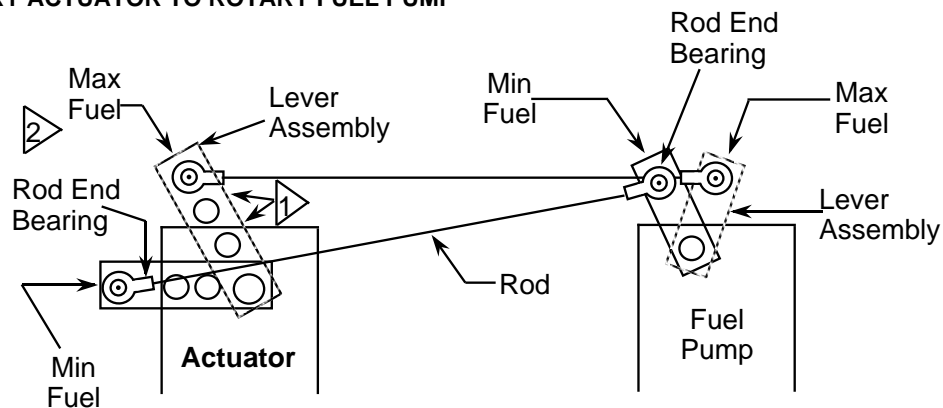

4.2.2 ROTARY ACTUATOR TO LINEAR FUEL PUMP

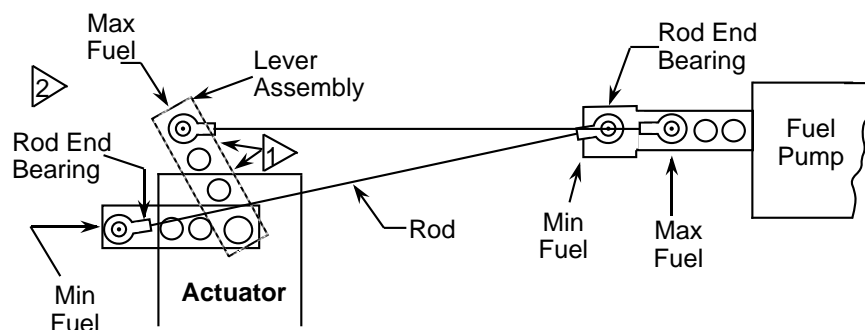

1 Choose hole in actuator lever which causes actuator to rotate through its maximum rotation to provide minimum to maximum fuel.

2 Non-Linear linkage to actuator is proper for best operation. Provides low GAIN at light loads and high GAIN at heavy loads.

4.3 TYPICAL WIRING DIAGRAM & CONTROLLER INSTALLATION DIMENSIONS
DIMENSIONS -- DYNA 8000 CONTROLLER -- DYN1 1065X and DYN1 1068X

Dimensions are in mm except as otherwise noted.
 Dimensions in [] are in inches.

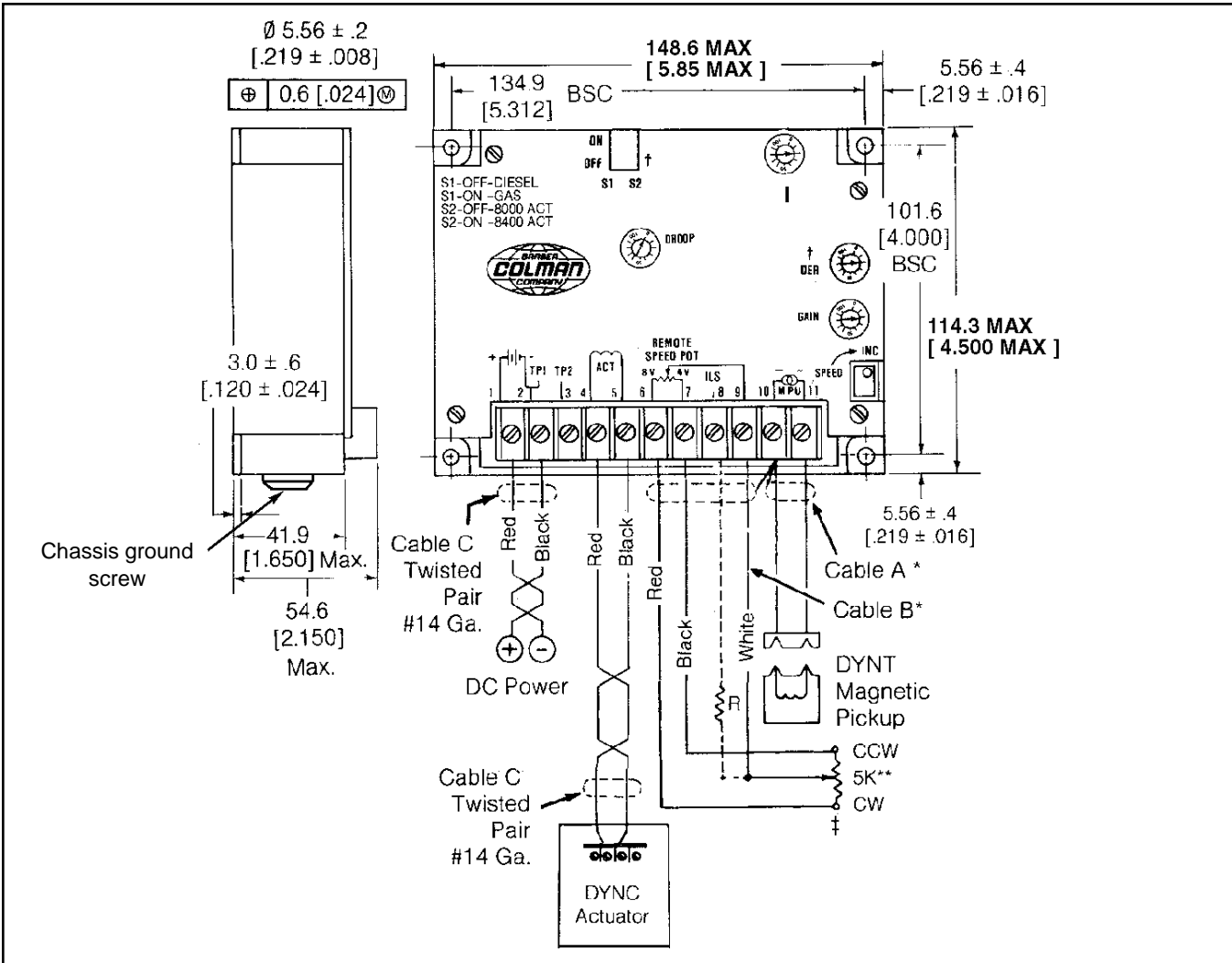

- Cable A -- DYNK-44-XX (specify length) (90° connector)
- Cable B -- E26-22 (specify length)
- Cable C -- DYNZ-70-4 (specify length) (terminal strip)
- Cable C -- DYNK-210 (specify length) (MS connector)

* Shielded cable -- Should be purchased from Barber-Colman or customer should purchase a cable with a wrapped mylar supported aluminum foil shield with a drain wire.

** Remote speed potentiometer and 499K ohm resistor is B-C P/N (DYNS-10000).

† The 5K remote speed potentiometer can be wired two different ways:

1. As shown by the solid line from the wiper of the 5K potentiometer and then connected to terminal #9 (no resistor required). Adjustable range is approximately ±5% at 1800 RPM.
2. As shown by the dashed line from the wiper of the 5K potentiometer through resistor R and then connected to terminal #8. Reducing the value of R increases the remote adjustable speed range.

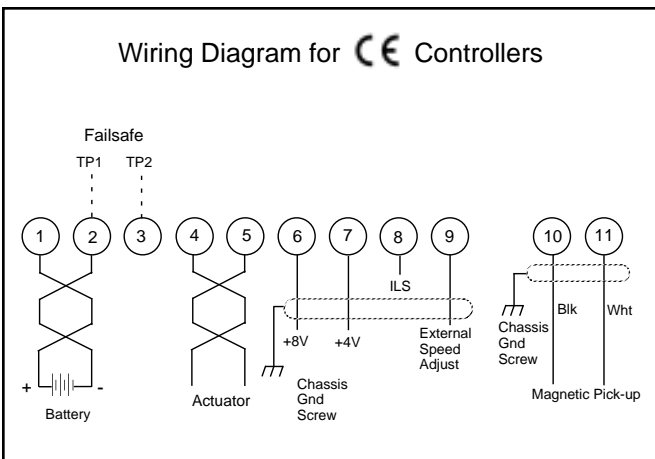

5. CALIBRATION OF DYNA 8000 SERIES CONTROLLER — DYN1-1065X

Part Number	Input Signal Frequency Maximum	Part Number	Input Signal Frequency Maximum
DYN1-10652-000-0-12/24] DYN1-10652-001-0-12/24*]	250 to 1200 Hz	DYN1-10654-000-0-12/24] DYN1-10654-001-0-12/24*]	2500 to 5000 Hz
DYN1-10653-000-0-12/24] DYN1-10653-001-0-12/24*]	1200 to 2500 Hz	DYN1-10656-000-0-12/24] DYN1-10656-001-0-12/24*]	5000 to 9000 Hz

* CE

NOTE

See Step 5.3 for proper procedures for setting switches S1 and S2, if you have a controller that has the two switches located on top of the controller.

5.1 CONNECTION INFORMATION

5.1.1 When using an ILS unit, the remote speed potentiometer may be left connected to the controller as shown.

5.1.2 When an ILS unit is used, connect 3-wire shielded cable to terminals 6, 7 and 8. Connect drain shield wire to terminal 10 at the controller only. Other end of drain shield wire is to be cut off and taped.

5.2 CALIBRATION AND ADJUSTMENTS

5.2.1 See diagram on page 8 for a reference guide before making any adjustments of the potentiometers, DROOP, I, GAIN and SPEED.

5.2.2 Power OFF - engine not operating.

5.2.3 Initial potentiometer settings:

5.2.3.1 Set the I adjustment three divisions from zero and the GAIN at the second division from zero.

5.2.3.2 For isochronous operation, set DROOP counterclockwise to minimum position as shown in paragraphs 3.5 and 3.6.

5.2.3.3 For DROOP operation, set DROOP potentiometer clockwise to obtain desired amount of DROOP from no-load to full load. Turning potentiometer clockwise increases DROOP.

NOTE

If the full 35° rotation of the actuator shaft is used and the linkage adjusted to use only the active fuel range, the maximum obtainable DROOP would be approximately 12% at full load.

5.3.3.4 See step 5.3 for setting switches S1 and S2.

5.2.4 If a remote speed potentiometer is used for narrow range, set it to mid-range. If the remote speed potentiometer is connected to terminals 6, 7 and 9, a resistor "R" in the wiper is not needed. This will provide approximately a ±5% adjustable speed range.

5.2.5 Start the engine.

5.2.5.1 Adjust the controller speed potentiometer until the engine is operating at the desired engine RPM. Clockwise increases engine RPM.

5.2.5.2 If the governor system is unstable, slightly reduce the GAIN setting.

NOTE

Except for the speed adjustment, the potentiometers have internal stops at the 0 and 100% positions.

5.2.6 With the engine unloaded, finalize the settings, I and GAIN adjustments as follows:

5.2.6.1 Turn the GAIN adjustment clockwise slowly until the actuator lever oscillates. (One may need to disturb actuator lever to cause oscillation.) Reduce the GAIN adjustment slowly counterclockwise until the lever is stable. Upset the lever by hand. If the lever oscillates 3 to 5 diminishing oscillations and stops, the setting is correct.

If system performance to load changes is satisfactory, omit step 5.2.6.2.

5.2.6.2 Reduce the GAIN setting counterclockwise one division. Next, turn the I adjustment fully clockwise while observing the actuator lever. If the lever does not become unstable, upset it by hand. When the lever slowly oscillates, turn the adjustment counterclockwise slowly until the lever is stable. Upset the lever again; it should oscillate 3 to 5 times and then become stable for optimum response.

NOTE

Use the settings of step 5.2.6.1 or step 5.2.6.2, whichever provides the best performance.

5.2.6.3 Unit is now calibrated.

5.3 ALL CONTROLLERS WITH REVISION J AND ABOVE HAVE SWITCHES S1 AND S2

These units have two new features now added to the DYN1 1065X series controllers. They are:

5.3.1 Two response ranges, for matching either the diesel or gas engine dynamics.

- Set S1 to the OFF position for diesel engine applications.
- Set S1 to the ON position for gas/gasoline engine applications.

5.3.2 Two actuator selections, so the same controller can be used on the DYNA 8000, DYNA 8200 or DYNA 8400 actuator.*

- Set S2 to the OFF position when using a DYNA 8000 actuator.
- Set S2 to the ON position when using a DYNA 8200 or DYNA 8400 actuator.

5.4. GENERAL INFORMATION ON S1 AND S2

- Switch S1 selects one of two integrating rate ranges. The diesel version integrates at twice the rate of the gas version
- Switch S2 selects the point at which actuator coil current level causes the integrator limit to be actuated. This level is nominally 6.3 amperes for the DYNA 8000 and 7.3 amperes for the DYNA 8200 and 8400 actuator.

* DYNA 8000 -- DYNC 11020 Series
DYNA 8200 -- DYNC 12000 Series
DYNA 8400 -- DYNC 14800 Series

These actuators do not have a potentiometer feedback transducer.

NOTE

For some diesel engines, better operation may be obtained by placing SW1 in "ON" position. If difficulty is experienced in "OFF" position, try SW1 ON and recalibrate.

5.5 PROPER PROCEDURES FOR SETTING SWITCHES S1 AND S2

Question: How do I know if the switches in the dual-in-line packages are correctly set as far as being in the OFF position or the ON position?

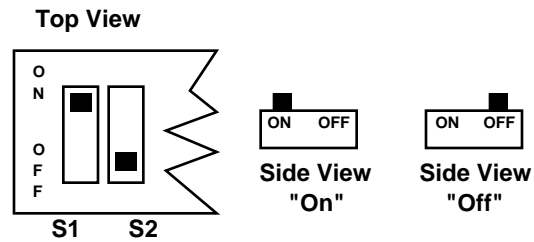

Answer: The drawings above should clarify any confusion about switch settings. The easiest way to set the switches is to apply pressure with a small pointed object until the switch clicks into position.

CAUTION

As a safety measure, the engine should be equipped with an independent overspeed shutdown device in the event of failure which may render the governor inoperative.

6. CALIBRATION PROCEDURE FOR 8000 GOVERNOR CONTROLLER — DYN1-10682, 10683, 10684, 10686

Part Number	Input Signal Frequency Maximum	Part Number	Input Signal Frequency Maximum
DYN1-10682-000-0-12/24] DYN1-10682-001-0-12/24*]	250 to 1200 Hz	DYN1-10684-000-0-12/24] DYN1-10684-001-0-12/24*]	2500 to 5000 Hz
DYN1-10683-000-0-12/24] DYN1-10683-001-0-12/24*]	1200 to 2500 Hz	DYN1-10686-000-0-12/24] DYN1-10686-001-0-12/24*]	5000 to 9000 Hz



NOTE

See Step 6.4 for proper procedures for setting switches S1 and S2, if you have a controller that has the two switches located on top of the controller.

6.1 CALIBRATION PROCEDURE

6.1.1 Observe that potentiometer settings are adjustable from zero to 100%. Each small division is 10%. The speed potentiometer is 10K, 20 turn.

6.1.2 Set the small dip switch, S1, for the correct engine. (See paragraph 6.4) Set switch S2 in the "OFF" position for actuator DYNA 8000 or in the "ON" position for DYNA 8200 and 8400.

6.1.3 If a remote speed potentiometer is used for narrow range, set to mid range.

6.2 INITIAL POTENTIOMETER SETTINGS

GAIN	20%
I	20%
D	30%
DROOP	Zero

6.2.1 For isochronous operation, set DROOP counterclockwise to minimum position as shown in paragraphs 3.5 and 3.6.

6.2.2 For DROOP operation, set DROOP potentiometer clockwise to obtain desired amount of DROOP from no-load to full load. Turning potentiometer clockwise increases DROOP.

6.3 START ENGINE (NO LOAD)

6.3.1 Adjust the controller speed potentiometer for desired engine speed.

6.3.2 Adjust the GAIN potentiometer clockwise until the engine begins to hunt. (If the engine remains stable at 100% GAIN, physically disrupt the actuator linkage by hand.) With the engine hunting, turn the GAIN potentiometer counterclockwise until stable.

6.3.3 Repeat step 6.3.2 for the "D" setting.

6.3.4 Repeat step 6.3.2 for the "I" setting.

6.3.5 After calibration, it may be necessary to readjust the speed.

6.3.6 Following the above calibration, conduct the following test. With the engine operating at rated speed, turn the electric governor off. When engine speed slows to approximately half of rated speed, turn the electric governor back on. Observe the overshoot. If there is a small hunt at steady state, slightly turn the "I" potentiometer counterclockwise until stable. In some cases, 2 to 3 Hz overshoot may be acceptable.

WARNING

For gas engines, make certain that method used does not put gas in exhaust which might result in an explosion.

If possible, operate the unit through various load ranges up to 100% to ensure stability.

6.4 CONTROLLERS HAVE SWITCHES S1 AND S2

These units have two new features now added to the DYN1 1068X series controllers. They are:

6.4.1 Two response ranges for matching either the diesel or gas engine dynamics.

- Set S1 to the OFF position for diesel engine applications.
- Set S1 to the ON position for gas/gasoline engine applications.

6.4.2 Two actuator selections, so the same controller can be used on the DYNA 8000, DYNA 8200 or DYNA 8400 actuator.*

- Set S2 to the OFF position when using a DYNA 8000 actuator.
- Set S2 to the ON position when using a DYNA 8200 or DYNA 8400 actuator.

6.5 GENERAL INFORMATION ON S1 AND S2

- Switch S1 selects one of two integrating rate ranges. The diesel version integrates at twice the rate of the gas version.
- Switch S2 selects the point at which actuator coil current level causes the integrator limit to be actuated. This level is nominally 6.3 amperes for the DYNA 8000 and 7.3 amperes for the DYNA 8200 and 8400 actuator.

6.6 PROPER PROCEDURES FOR SETTING SWITCHES S1 AND S2

Question: How do I know if the switches in the dual-in-line packages are correctly set as far as being in the OFF position or the ON position?

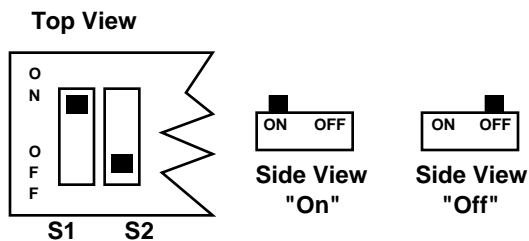

Answer: The drawings above should clarify any confusion about switch settings. The easiest way to set the switches is to apply pressure with a small pointed object until the switch clicks into position.

* DYNA 8000 -- DYNC 11020 Series
DYNA 8200 -- DYNC 12000 Series
DYNA 8400 -- DYNC 14800 Series

These actuators do not have a potentiometer feedback transducer.

NOTE

A warm engine is normally more stable than a cold one. If the governor is adjusted on a warm engine, turn the adjustment potentiometers counterclockwise 5% (1/2 div.) to ensure a stable engine when started cold.

CAUTION

As a safety measure, the engine should be equipped with an independent overspeed shutdown device in the event of failure which may render the governor inoperative.

7. DYNA 8000 SERIES TROUBLESHOOTING CHART

7.1 PROBLEM: GOVERNOR IS COMPLETELY DEAD AND ACTUATOR LEVER STAYS AT MINIMUM POSITION WHEN POWER IS APPLIED TO GOVERNOR.

	Means of Detection	Corrective Action
7.1.1	Check battery voltage at terminals 1 and 2 on controller. Terminal 1 is positive.	Check battery connections and contacts for turning power ON to the controller.
7.1.2	Check for proper linkage setup.	Correct and free linkage.
7.1.3	Magnetic pickup signal absent or too low. Measure AC voltage across terminals 10 and 11 while cranking the engine. Voltage should be min. 2.5 VAC. Note: The voltmeter should have an impedance of 5000 ohms/volts or higher.	Check pole tip gap over gear tooth. Should be .037 mm \pm 0.127 mm (0.015" \pm 0.005").
7.1.4	Measure the resistance of the magnetic pickup coil. This should be above 150 ohms.	If there is an open or shorted coil, replace the magnetic pickup.
7.1.5	Measure the resistance of each pin to the metal case of the magnetic pickup. No continuity should be evident.	If there is continuity to case, replace the magnetic pickup.
7.1.6	DC SUPPLY OFF. Place an insulated jumper between terminals 2 and 3 (TP1 & TP2). With DC ON, the actuator should go to full stroke. DC voltage at terminals 4 and 5 should be within 3 volts of the supply.	If the actuator still does not move to full stroke, continue with steps below.
7.1.7	Measure actuator coil resistance: <u>DYNA 8000</u> 12 VDC unit. Coil resistance 0.75 \pm 0.2 ohms. 24 VDC unit. Coil resistance 2.3 \pm 0.4 ohms. <u>DYNA 8200</u> 12 VDC unit. Coil resistance .710 \pm 0.2 ohms. 24 VDC unit. Coil resistance 1.600 \pm 0.4 ohms. <u>DYNA 8400</u> 24 VDC unit. Coil resistance 1.630 \pm 0.4 ohms.	If actuator coil is open or shorted to case, replace actuator. If governor still does not operate, continue with steps below.
7.1.8	Measuring the resistance of each coil lead to the actuator case should indicate an open circuit on a low scale of the ohm meter.	If continuity is detected, replace the actuator.
7.1.9	With the DC to the governor ON and the engine OFF, measure the DC voltage from terminal 6 (+) to terminal 2 (-). This should be approx. 8 VDC.	If 8 VDC is not present, replace the controller.
7.1.10	Between terminal 7 (+) to terminal 2 (-), the voltage should be approx. 4 VDC.	If 4 VDC is not present, replace the controller.

7.2 PROBLEM: ACTUATOR GOES TO FULL STROKE WHEN DC POWER IS TURNED ON (ENGINE IS NOT OPERATING).

	Means of Detection	Corrective Action
7.2.1	Check magnetic pickup leads for proper shielded wire or open shield.	Verify and correct wiring as necessary.
7.2.2	Be sure there is no jumper between terminals 2 and 3.	Verify and correct wiring as necessary.
7.2.3	Failsafe circuit in the controller may be damaged or defective.	Replace controller.
7.2.4	With DC power OFF remove leads at actuator. Check continuity of each terminal to case. There should be no continuity between any terminal and case of the controller.	If continuity is detected, replace the controller.
7.2.5	If remote speed potentiometer has been connected to terminals 6, 7 and 9 of the controller, DISCONNECT THESE LEADS.	Turn DC power ON to the governor if the actuator is now normal. Proceed to step 7.3.1.

7.3 PROBLEM: IMPROPER OPERATION FROM REMOTE SPEED POTENTIOMETER

	Means of Detection	Corrective Action
7.3.1	Investigate wiring to remote speed potentiometer for open or shorted circuits.	Check wiring.
7.3.2	If the leads at terminals 6 and 7 to the remote speed potentiometer are reversed, speed control by the remote speed potentiometer will be reversed.	Correct wiring.
7.3.3	Lead wire to remote speed setting potentiometer should be 3-wire shielded cable.	Verify that the drain shield wire is isolated from ground at the potentiometer.
7.3.4	If terminal 7 lead to the remote speed potentiometer is open, engine speed will go high.	Correct the wiring.
7.3.5	If lead 9 (wiper lead to remote potentiometer) is open, there will be no control by the remote speed potentiometer.	Verify and correct wiring.
7.3.6	If lead 6 to the clockwise terminal of the remote speed potentiometer is open, speed will remain at the value set in the controller.	

7.4 PROBLEM: ERRATIC GOVERNOR OPERATION

	Means of Detection	Corrective Action
7.4.1	Measure DC voltage at 1 and 2 on controller terminal strip. Normal battery voltage should be indicated.	If nominal voltage is present, wiring is correct.
7.4.2	Low battery voltage 20% below rated can cause erratic operation.	Check battery and charging system.
7.4.3	RFI noise due to incorrect shielding.	Correct wiring.
7.4.4	RFI noise fed through power supply leads.	Connect power leads directly to the battery.

7.5 PROBLEM: SLOW, SMALL AMPLITUDE HUNTING OF SPEED OR FREQUENCY

Means of Detection	Corrective Action
7.5.1 Sticking or very loose linkage.	Correct Linkage.

7.6 PROBLEM: FAST OSCILLATION OF GOVERNOR LINKAGE

Means of Detection	Corrective Action
7.6.1 Verify calibration settings of the controller.	Readjust settings as necessary.

7.7 PROBLEM: ENGINE WILL NOT START -- ACTUATOR GOES TO FULL FUEL DURING CRANKING

Means of Detection	Corrective Action
7.7.1 Make sure fuel is available.	Check fuel to engine. Check for correct wiring to the automatic shutdown circuits.
7.7.2 Air may be trapped in fuel line.	Check fuel lines for leaks.
7.7.3 Try to operate engine manually.	

8. ACTUATOR INSTALLATION DIMENSIONS

**DYNC-11020-000
STANDARD
ACTUATOR —
CLOCKWISE
ROTATION**

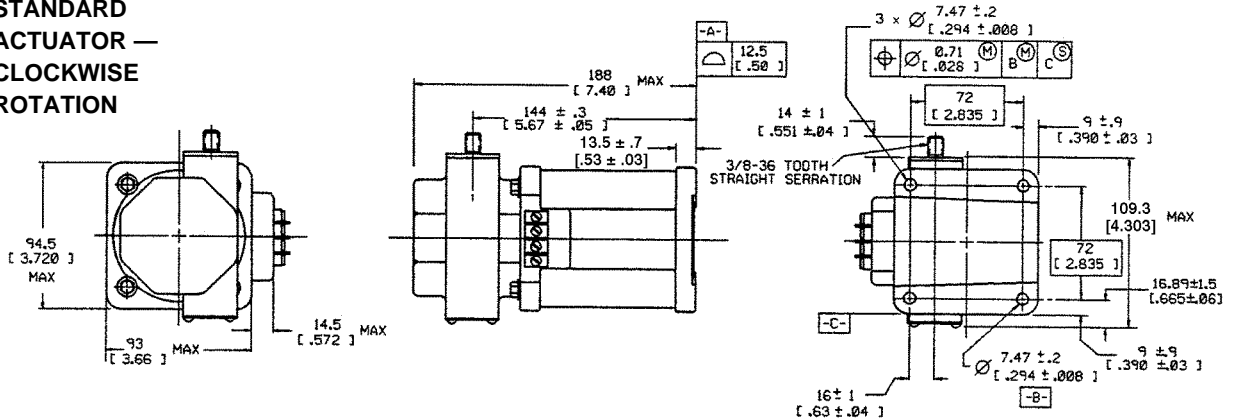

**DYNC-11020-300
SIDE MOUNTED
ACTUATOR —
CLOCKWISE
ROTATION**

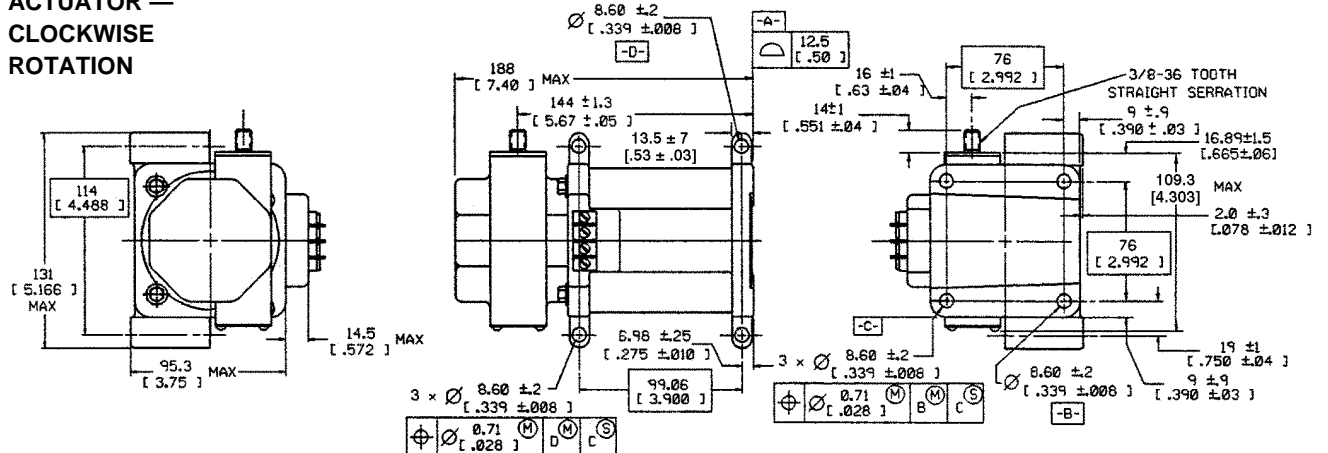

DYNC-11024-000

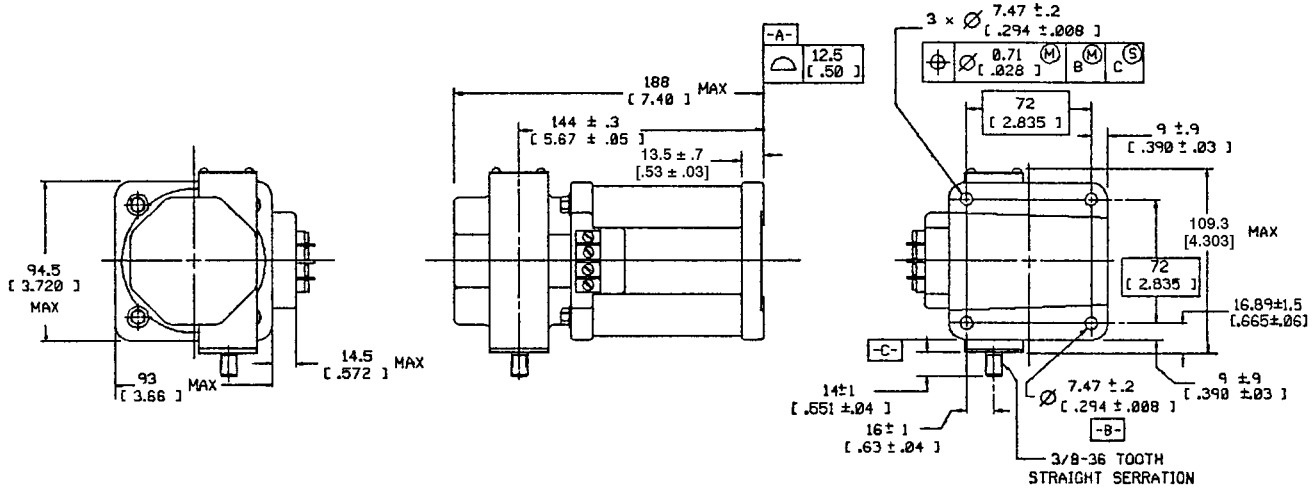

DYNC-11024-300
SIDE MOUNTED
ACTUATOR —
COUNTERCLOCKWISE
ROTATION

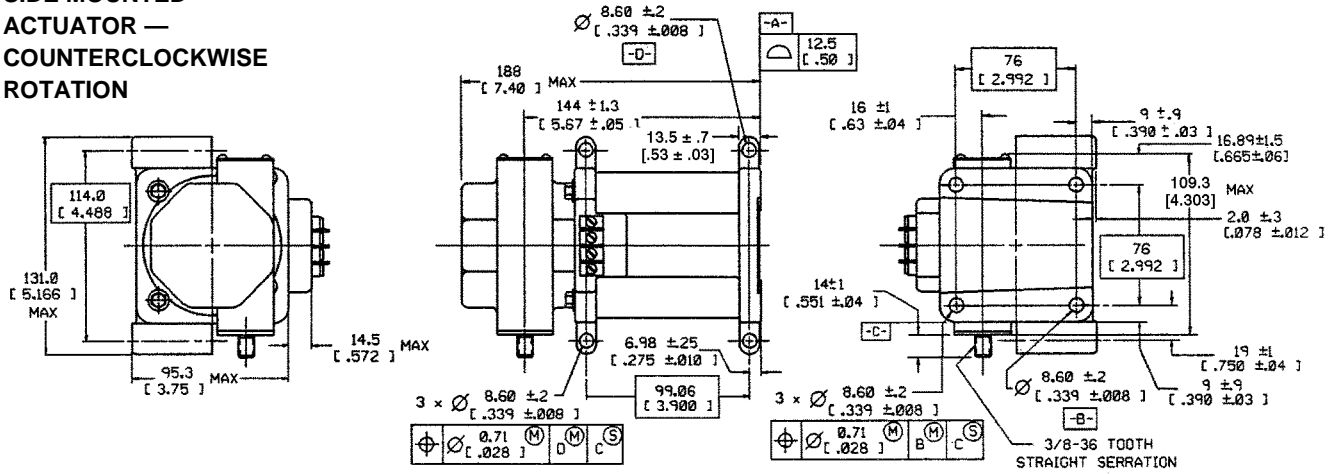

DYNC-12000-000

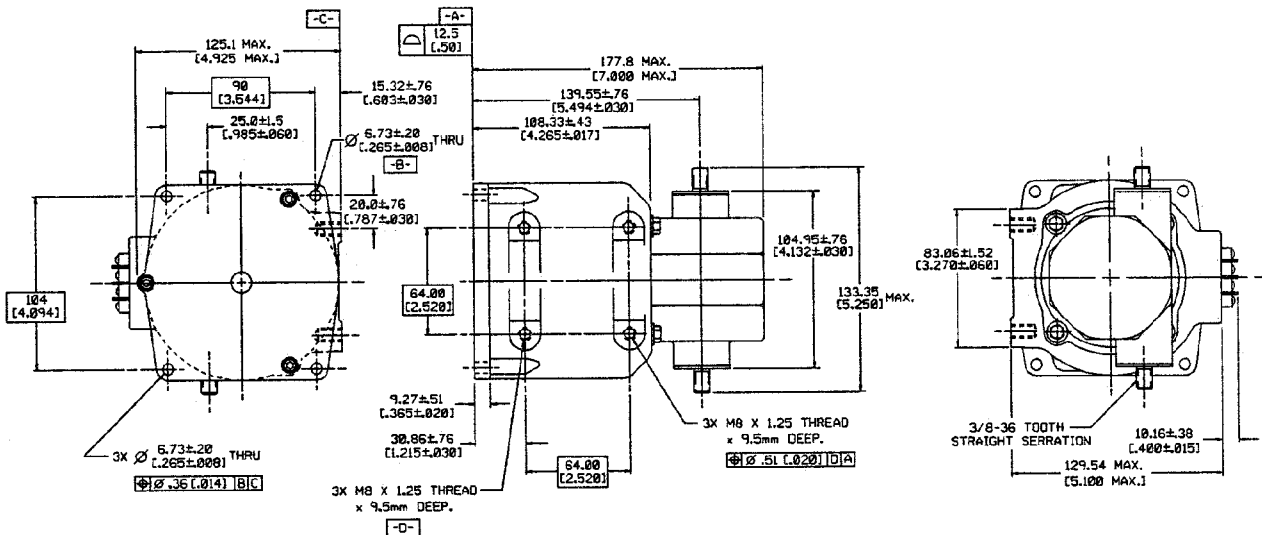

DYNC-14800-000
TERMINAL STRIP CONNECTION

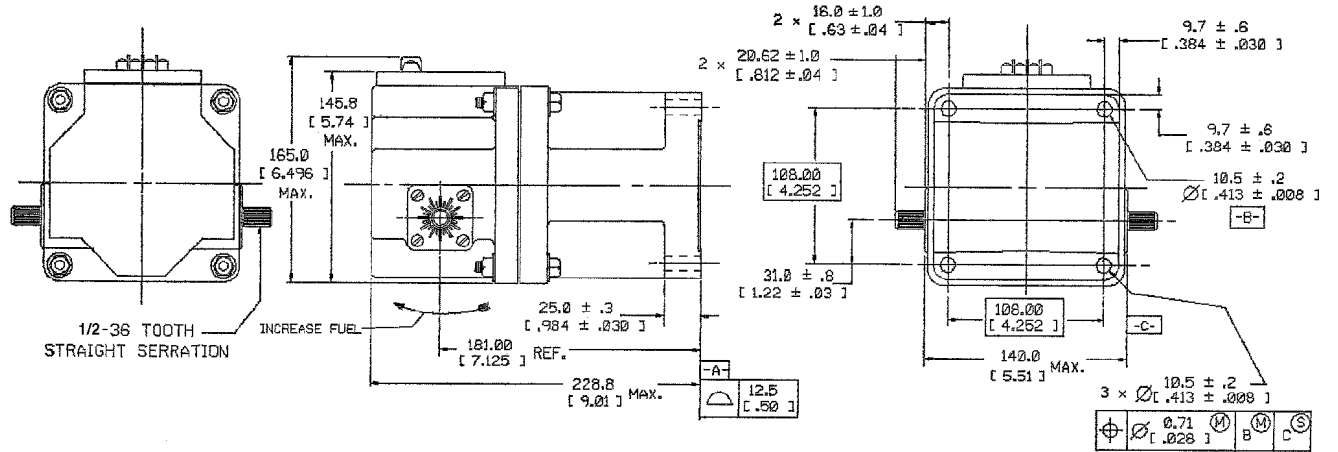

DYNC-14801-000
2-PIN MS CONNECTOR CONNECTION

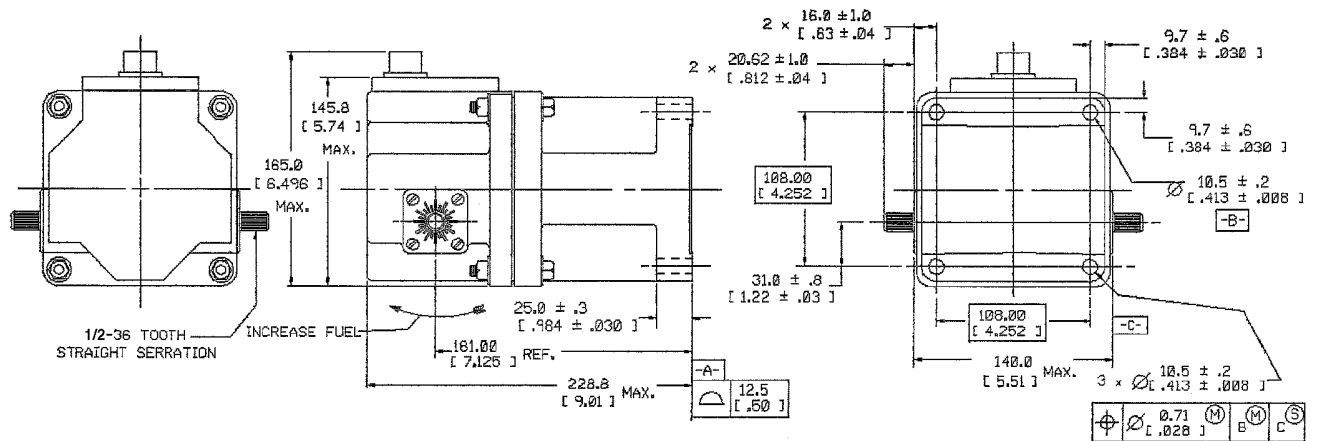

DYNC-11020-401
UL APPROVAL, HAZARDOUS DUTY, CLASS 1, DIVISION 2, GROUP D
CLOCKWISE UNIT

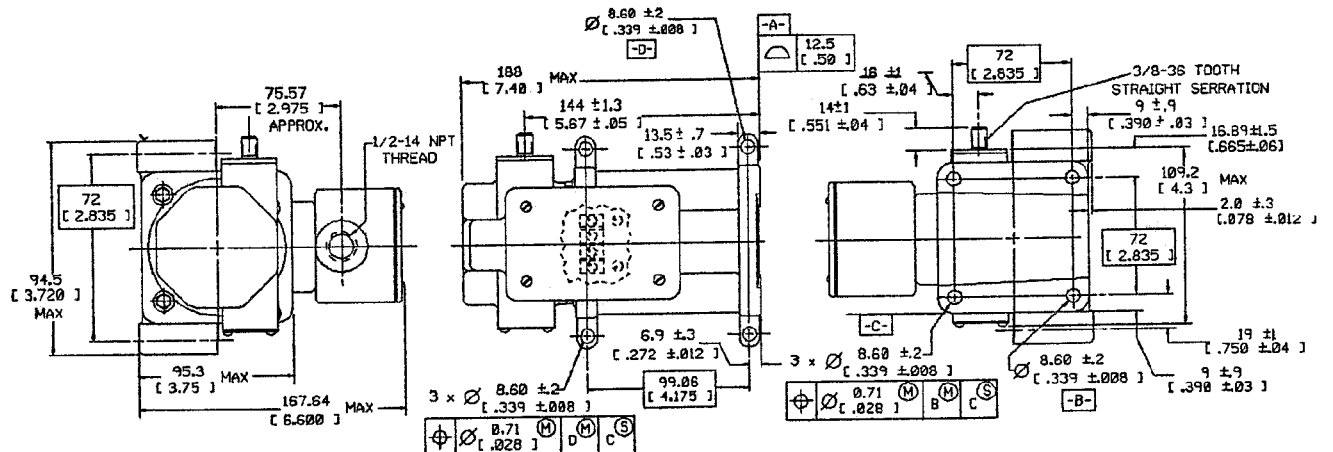



CALIBRATION PROCEDURE FOR DYNA 8000 SERIES GOVERNOR CONTROLLERS

Part Number	Input Signal Frequency Maximum	Part Number	Input Signal Frequency Maximum
DYN1-10682-000-0-12/24*	250 to 1200 Hz	DYN1-10684-000-0-12/24*	2500 to 5000 Hz
DYN1-10682-001-0-12/24*		DYN1-10684-001-0-12/24*	
DYN1-10683-000-0-12/24*	1200 to 2500 Hz	DYN1-10686-000-0-12/24*	5000 to 9000 Hz
DYN1-10683-001-0-12/24*		DYN1-10686-001-0-12/24*	

* C E

NOTE

See Step 4.0 for proper procedures for setting switches S1 and S2, if you have a controller that has the two switches located on top of the controller.

1.0 CALIBRATION PROCEDURE

1.1 Observe that potentiometer settings are adjustable from zero to 100%. Each small division is 10%. The speed potentiometer is 10K, 20 turn.

1.2 Set the small dip switch, S1, for the correct engine. (See paragraph 4) Set switch S2 in the "OFF" position for actuator DYNA 8000 or in the "ON" position for DYNA 8200 and 8400.

1.3 If a remote speed potentiometer is used for narrow range, set to mid range.

2.0 INITIAL POTENTIOMETER SETTINGS

GAIN = 20%	D = 30%
I = 20%	DROOP = Zero

2.1 For isochronous operation, set DROOP counterclockwise to minimum position as shown in Figure 1.

2.2 For DROOP operation, set DROOP potentiometer clockwise to obtain desired amount of DROOP from no-load to full load. Turning potentiometer clockwise increases DROOP.

3.0 START ENGINE (NO LOAD)

3.1 Adjust the controller speed potentiometer for desired engine speed.

NOTE

A warm engine is normally more stable than a cold one. If the governor is adjusted on a warm engine, turn the adjustment potentiometers counterclockwise 5% (1/2 div.) to ensure a stable engine when started cold.

CAUTION

As a safety measure, the engine should be equipped with an independent overspeed shutdown device in the event of failure which may render the governor inoperative.

3.2 Adjust the GAIN potentiometer clockwise until the engine begins to hunt. (If the engine remains stable at 100% GAIN, physically disrupt the actuator linkage by hand.) With the engine hunting, turn the GAIN potentiometer counterclockwise until stable.

3.3 Repeat step 3.2 for the "D" setting.

3.4 Repeat step 3.2 for the "I" setting.

3.5 After calibration, it may be necessary to readjust the speed.

3.6 Following the above calibration, conduct the following test. With the engine operating at rated speed, turn the electric governor off. When engine speed slows to approximately half of rated speed, turn the electric governor back on. Observe the overshoot. If the overshoot is too great, turn the "I" potentiometer clockwise to lessen the overshoot. If there is a small hunt at steady state, slightly turn the "I" potentiometer counterclockwise until stable. In some cases, 2 to 3 Hz overshoot may be acceptable.

WARNING

For gas engines, make certain that method used does not put gas in exhaust which might result in an explosion.

If possible, operate the unit through various load ranges up to 100% to ensure stability.

4.0 CONTROLLERS HAVE SWITCHES S1 AND S2

These units have two features now added to the DYN1 1068X series controllers. They are:

4.1 Two response ranges for matching either the diesel or gas engine dynamics.

- Set S1 to the OFF position for diesel engine applications.
- Set S1 to the ON position for gas/gasoline engine applications.

4.2 Two actuator selections, so the same controller can be used on the DYNA 8000, DYNA 8200 or DYNA 8400 actuator.*

- Set S2 to "OFF" position when using a DYNA 8000 actuator.
- Set S2 to "ON" position when using a DYNA 8200 or DYNA 8400 actuator.

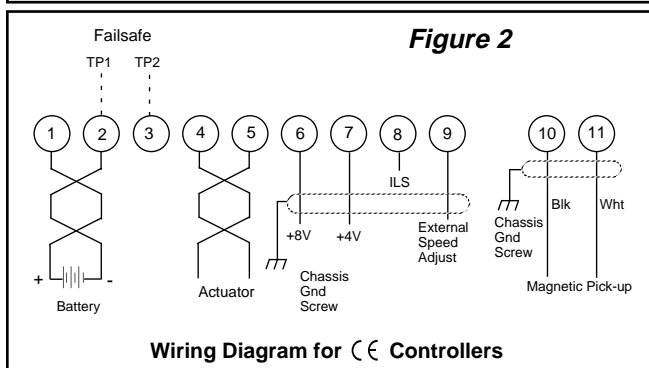
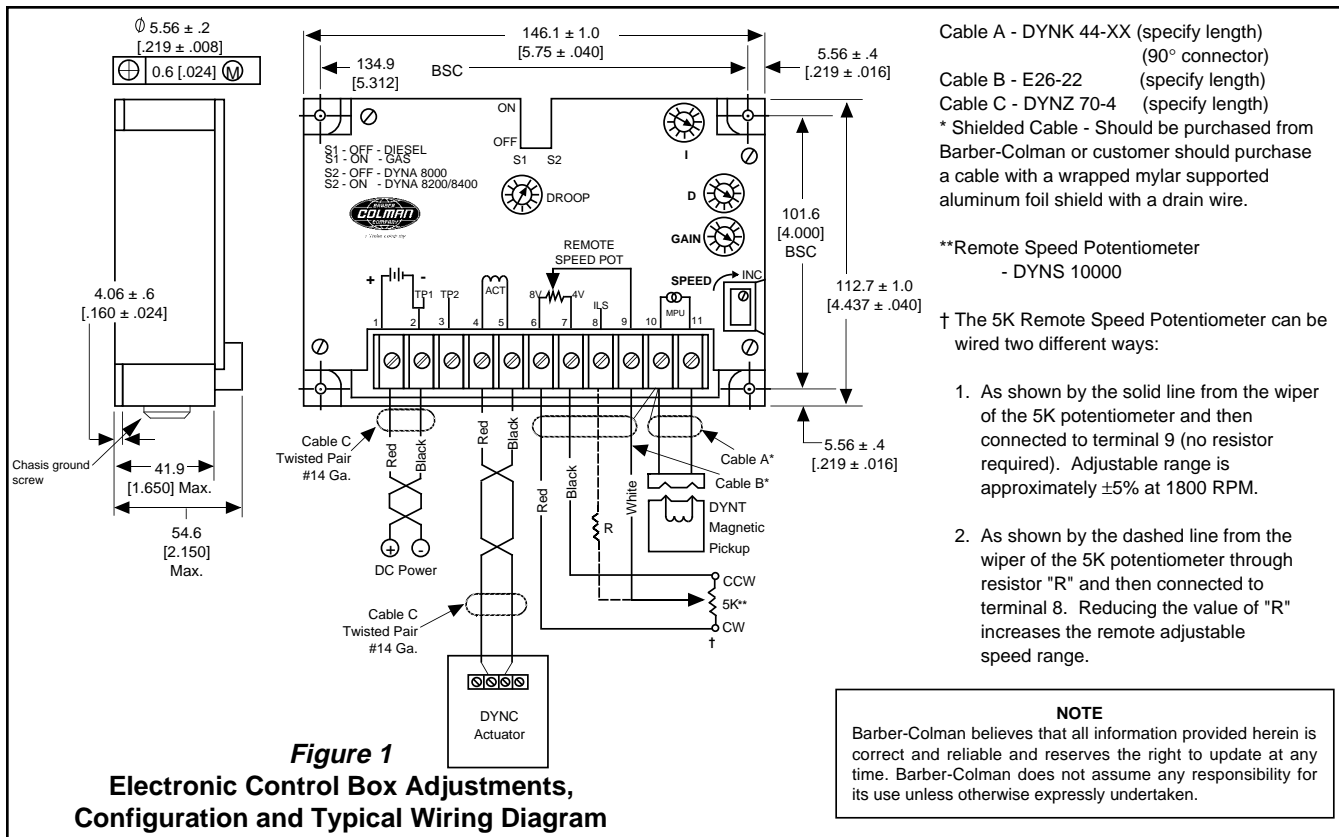

5.0 GENERAL INFORMATION ON S1 AND S2

- Switch S1 selects one of two integrating rate ranges. The diesel version integrates at twice the rate of the gas version.
 - Switch S2 selects the point at which actuator coil current level causes the integrator limit to be actuated. This level is nominally 6.3 amperes for the DYNA 8000 and 7.3 amperes for the DYNA 8200 and 8400 actuator.
- * DYNA 8000 — DYNC 11020 Series
 DYNA 8200 — DYNC 12000 Series
 DYNA 8400 — DYNC 14800 Series
- These actuators do not have a potentiometer feedback transducer.

6.0 PROPER PROCEDURES FOR SETTING SWITCHES S1 AND S2

Question: How do I know if the switches in the dual-in-line packages are correctly set as far as being in the OFF position or the ON position?

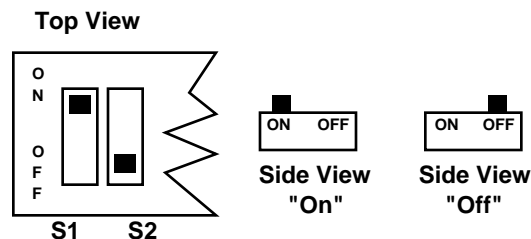

Answer: The drawings above should clarify any confusion about switch settings. The easiest way to set the switches is to apply pressure with a small pointed object until the switch clicks into position.

Barber-Colman DYNA Products

1354 Clifford Avenue (Zip 61111) Telephone (815) 637-3000
 P.O. Box 2940 Facsimile (815) 877-0150
 Loves Park, IL 61132-2940 www.dynaproducts.com
 United States of America

In Europe contact: Barber-Colman GmbH

Am Neuen Rheinhafen 4, D-67346 Speyer, Germany
 Telephone (49) 6232 29903, Facsimile (49) 6232 299155

In Japan contact: Ranco Japan Ltd.

Shiozaki Bldg. 7-1, 2-chome, Hirakawa-Cho, Chiyoda-Ku
 Tokyo 102, Japan
 Telephone (81) 3 3261 4293, Facsimile (81) 3 3264 4691



**CALIBRATION AND TROUBLESHOOTING
FOR BASIC LINEAR CONTROLLERS**

MODELS
DYN1-10704*
DYN1-10714
DYN1-10724*
DYN1-10734

*CE

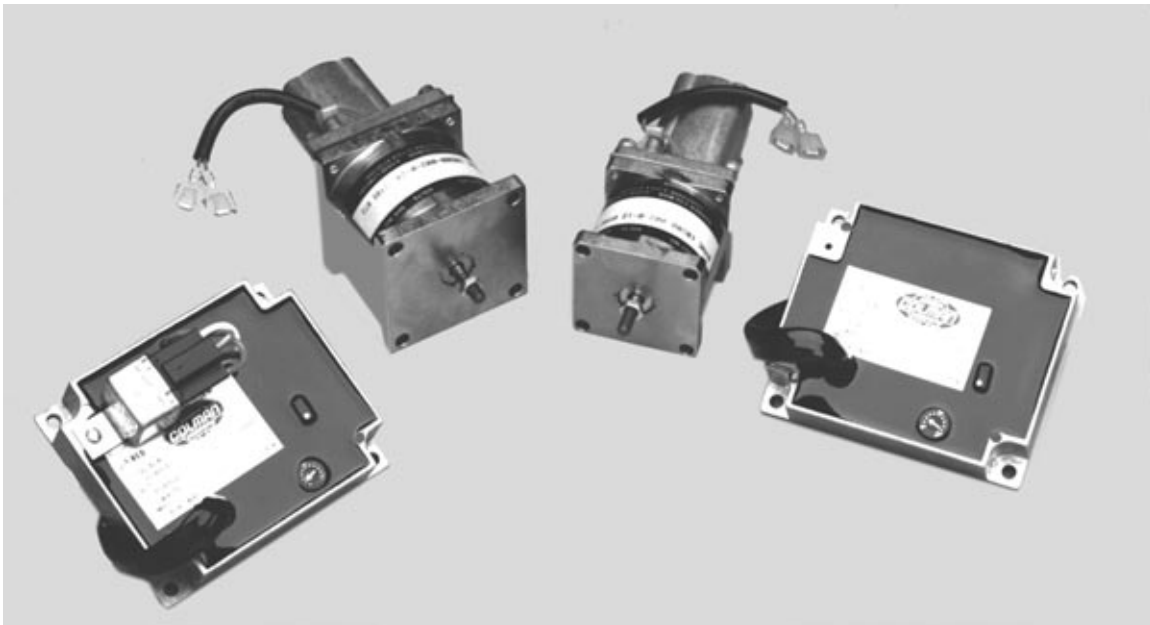

GENERAL INFORMATION

The DYN1-10704 and 10724 controllers are basic controllers without an overspeed. The 10704 controller is normally used on diesel engines and the 10724 is normally used on ignition engines.

The DYN1-10714 and 10734 controllers are also basic controllers with overspeed protection 12.5% above set speed. The 10714 controller is normally used on diesel engines and the 10734 controller is normally used on ignition engines.

TYPICAL WIRING DIAGRAM

General information, wiring and calibration procedure for the DYN1-10704, 10714, 10724 and 10734 controllers for the linear governor system.

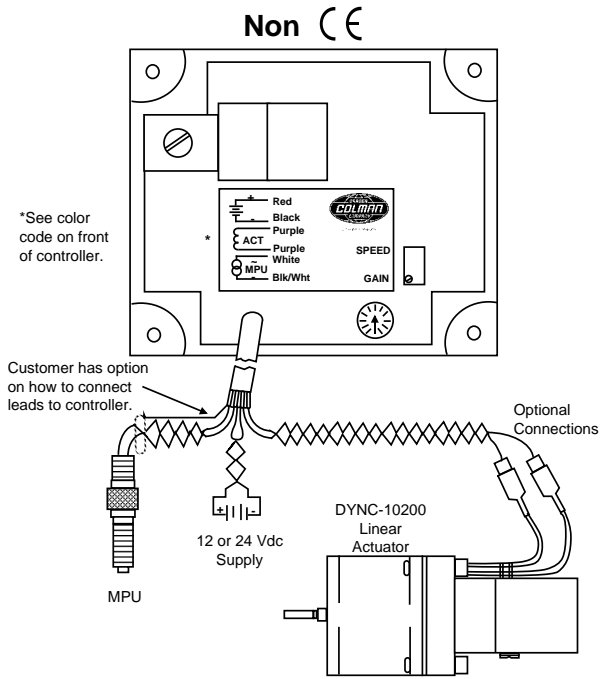

Note: The shield on the MPU is to be connected to the black wire along with one of the MPU conductors.

Figure 1

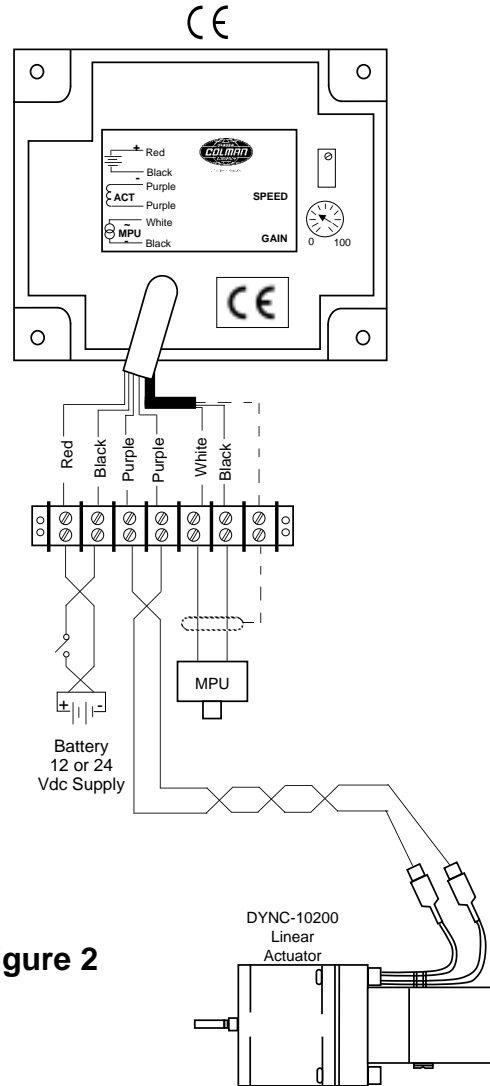

Figure 2

CALIBRATION

1. With no power to the governor, adjust the GAIN to 9:00 o'clock.
2. Start the engine and adjust the speed by turning the SPEED pot clockwise to desired speed.

NOTE

Controllers are factory adjusted to minimum RPM. However, for safety, one should be capable of disabling the engine if an overspeed should exist.

3. At no load, turn the GAIN potentiometer clockwise until the engine begins to hunt. If the engine does not hunt, physically upset the governor linkage.
4. Turn the GAIN potentiometer counterclockwise until stable.

WIRING

All four non CE controllers are wired as shown in Figure 1 Wiring Diagram.

1. Red to battery positive.
2. Black to battery negative.
3. Purple to the actuator, no polarity.
4. White to one side of the magnetic pickup.
5. Black and white to the other side of the magnetic pickup connected with the shield drain wire.

Controllers with CE conformity are wired as shown in Figure 2 Wiring Diagram.

LINEAR TROUBLESHOOTING CHART

Problem	Detection	Corrective Action
<p>I. System appears dead. (Actuator fails to move to full fuel)</p>	<p>1. CHECK BATTERY VOLTAGE AT CONTROLLER with power switch "ON". Measure DC battery voltage between the Red (+) and Black (-) leads. Battery voltage should be present.</p>	<p>Check connections to battery.</p>
	<p>2. CHECK LINKAGE. Manually operate linkage to see that it is not sticking or binding.</p>	<p>Free linkage.</p>
	<p>3. NO SIGNAL OR WEAK SIGNAL FROM MAGNETIC PICKUP. Measure AC voltage between the White and Black/White leads on controller while cranking engine. Voltage should be 2.5 volts RMS or greater. (AC input impedance of meter must be 5000 ohms/volt or greater.)</p>	<p>Check for damage to or improper adjustment of magnetic pickup. Replace or re-adjust.</p>
	<p>4. CHECK ACTUATOR with power "ON" to controller. Measure following terminals on control box with respect to the Black lead. All points should read BATTERY VOLTAGE. (+0.00/-0.75 VDC)</p> <ul style="list-style-type: none"> a. Purple lead to Black lead on controller. b. Second Purple lead to Black lead on controller. (Continue this test only if battery voltage is not present.) c. Following checks are terminals on the actuator and the Black lead on controller. <ul style="list-style-type: none"> 1) Low voltage (1.0-2.0 VDC) at either actuator connector. 2) Battery voltage at both actuator connectors. 3) Battery voltage at one actuator lead but not at the other. 	<p>Replace controller if battery voltage is not present at both Purple leads.</p> <p>Broken actuator lead.</p> <p>Broken actuator lead.</p> <p>Replace actuator.</p>
<p>II. Actuator lever goes to full fuel whenever the power is turned "ON" and engine is not running.</p>	<p>1. CHECK CONTROLLER by removing actuator lead to Purple lead and turning power "ON" to controller.</p> <ul style="list-style-type: none"> a. Actuator goes to full fuel. b. Actuator does not go to full fuel. <p>Note: Turn off power and reconnect Purple lead.</p>	<p>Check for shorted actuator lead.</p> <p>Replace Controller because it should not cause actuator lever to go to full fuel with engine not running.</p>
<p>III. Actuator hunts during operation.</p>	<p>1. Linkage or rod end bearings sticking or binding.</p>	<p>Lubricate or replace.</p>
	<p>2. Improper linkage arrangement. (Stroke too short or improper non-linear linkage used)</p>	<p>See installation information.</p>
	<p>3. Improper governor adjustment.</p>	<p>Readjust calibration.</p>
	<p>4. Inadequate power supply voltage.</p> <ul style="list-style-type: none"> a. Turn power switch "OFF". b. Connect a DC voltmeter to Red and Black leads at control box. c. Disconnect both leads to actuator at Purple leads of control box. d. Connect one actuator lead to the Red lead and one actuator lead to the Black lead of the control box. e. Momentarily turn "ON" the DC power. The actuator should go to full fuel and the DC voltage must be greater than 80% of supply. <p style="margin-left: 40px;">24 VDC @ 80% = 19.2 VDC 12 VDC @ 80% = 9.6 VDC</p> <p>Note: Reconnect actuator leads properly after completing this test.</p>	<p>If actuator doesn't get to full fuel, then check actuator leads. If voltage is less than specified, check for loose or poor connections to battery, or get larger supply leads or larger power supply.</p>

CAUTION

As a safety measure, the engine should be equipped with an independent overspeed shutdown device in the event of failure which may render the governor inoperative.

NOTE

Barber-Colman believes that all information provided herein is correct and reliable and reserves the right to update at any time. Barber-Colman does not assume any responsibility for its use unless otherwise expressly undertaken.

Barber-Colman DYNA Products

1354 Clifford Avenue (Zip 61111) Telephone (815) 637-3000
P.O. Box 2940 Facsimile (815) 877-0150
Loves Park, IL 61132-2940 www.dynaproducts.com
United States of America

In Europe contact: Barber-Colman GmbH

Am Neuen Rheinhafen 4, D-67346 Speyer, Germany
Telephone (49) 6232 29903, Facsimile (49) 6232 299155

In Japan contact: Ranco Japan Ltd.

Shiozaki Bldg. 7-1, 2-chome, Hirakawa-Cho, Chiyoda-Ku
Tokyo 102, Japan
Telephone (81) 3 3261 4293, Facsimile (81) 3 3264 4691

An Invensys company

F-24419-1



CALIBRATION PROCEDURE AND TROUBLESHOOTING FOR LINEAR GOVERNOR CONTROLLERS

Table with 4 columns: Part Number, Input Signal Frequency Maximum, Part Number, Input Signal Frequency Maximum. Lists part numbers and their corresponding frequency ranges.

NOTE

See Step 4.0 for proper procedures for setting switches S1 and S2 if you have a controller that has the two switches located on top of the controller.



1.0 CALIBRATION PROCEDURE

- 1.1 Observe that potentiometer settings are adjustable from zero to 100%. Each small division is 10%. The speed potentiometer is 10K, 20 turn.
1.2 Set the small dip switch, S1, for the correct engine. (See paragraph 4) Set switch S2 in the "OFF" position for actuator DYNC 10200 and DYNC 10202 or in the "ON" position for DYNC 10500 and DYNC 10502
1.3 If a remote speed potentiometer is used for narrow range, set to mid range.

3.2 Adjust the GAIN potentiometer clockwise until the engine begins to hunt. (If the engine remains stable at 100% GAIN, physically disrupt the actuator linkage by hand.) With the engine hunting, turn the GAIN potentiometer counterclockwise until stable.

NOTE

A warm engine is normally more stable than a cold one. If the governor is adjusted on a warm engine, turn the adjustment potentiometers counterclockwise 5% (1/2 div.) to ensure a stable engine when started cold.

2.0 INITIAL POTENTIOMETER SETTINGS

Table with 2 columns: Setting Name, Percentage. GAIN 20%, I 20%, D 30%, DROOP Zero

- 2.1 For isochronous operation, set DROOP counterclockwise to minimum position as shown in Figure 1.
2.2 For DROOP operation, set DROOP potentiometer clockwise to obtain desired amount of DROOP from no-load to full load. Turning potentiometer clockwise increases DROOP.

- 3.3 Repeat step 3.2 for the "D" setting.
3.4 Repeat step 3.2 for the "I" setting.
3.5 After calibration, it may be necessary to readjust the speed.
3.6 If the engine is a diesel, following the above calibration, conduct the following test. With the engine operating at rated speed, turn the electric governor off. When engine speed slows to approximately half of rated speed, turn the electric governor back on. Observe the overshoot. If the overshoot is too great, turn the "I" potentiometer counterclockwise to lessen the overshoot. If there is a small hunt at steady state, slightly turn the "I" potentiometer counterclockwise until stable. In some cases, 2 to 5 Hz overshoot may be acceptable.
3.7 If the engine is an ignition type using compressed fuel such as natural gas or LP, stop the engine and restart in the normal manner to check overshoot.

3.0 START ENGINE (NO LOAD)

3.1 Adjust the controller speed potentiometer for desired engine speed.

If possible, operate the unit through various load ranges up to 100% to ensure stability.



4.0 CONTROLLERS HAVE SWITCHES S1 AND S2

These units have two features now added to the DYN1 1075X series controllers. They are:

4.1 Two response ranges for matching either the diesel or gas engine dynamics.

- Set S1 to the OFF position for diesel engine applications.
- Set S1 to the ON position for gas/gasoline engine applications.

4.2 Two actuator selections, so the same controller can be used on the DYNA 2000 or DYNA 2500 actuator.*

- Set S2 to the OFF position when using a DYNA 2000 actuator or DYN1-1020X.
- Set S2 to the ON position when using a DYNA 2500 actuator or DYN1-1050X.

5.0 GENERAL INFORMATION ON S1 AND S2

- Switch S1 selects one of two integrating rate ranges. The diesel version integrates at twice the rate of the gas version.
- Switch S2 selects the point at which actuator coil current level causes the integrator limit to be actuated. This level varies for 12 and 24 volt as shown below.

	12 Volt	24 Volt
DYNA 2000 — S2 OFF	5.1A	2.3A
DYNA 2500 — S2 ON	7.2A	3.4A

* DYNA 2000 — DYNC 10200 and DYNC 10202
DYNA 2500 — DYNC 10500 and DYNC 10502

These actuators do not have a potentiometer feedback transducer.

6.0 PROPER PROCEDURES FOR SETTING SWITCHES S1 AND S2

Question: How do I know if the switches in the dual-in-line packages are correctly set as far as being in the OFF position or the ON position?

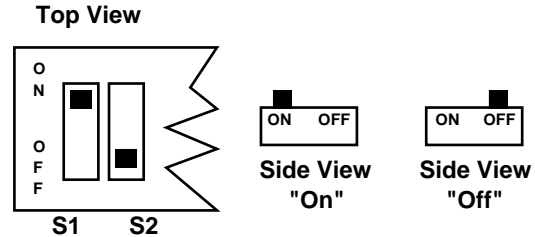

Answer: The drawings above should clarify any confusion about switch settings. The easiest way to set the switches is to apply pressure with a small pointed object until the switch clicks into position.

CAUTION

As a safety measure, the engine should be equipped with an independent overspeed shutdown device in the event of failure which may render the governor inoperative.

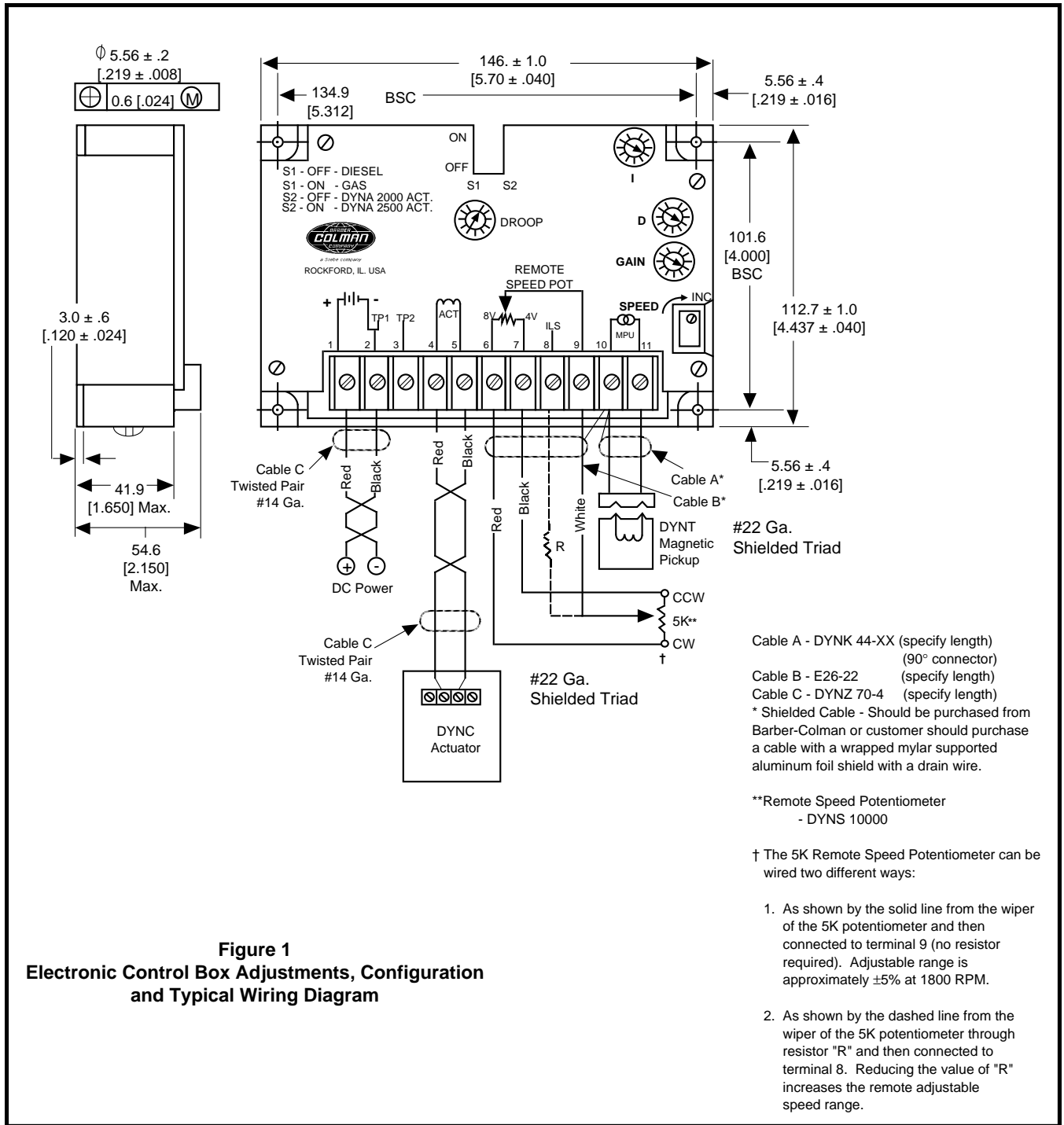

Figure 1
Electronic Control Box Adjustments, Configuration and Typical Wiring Diagram

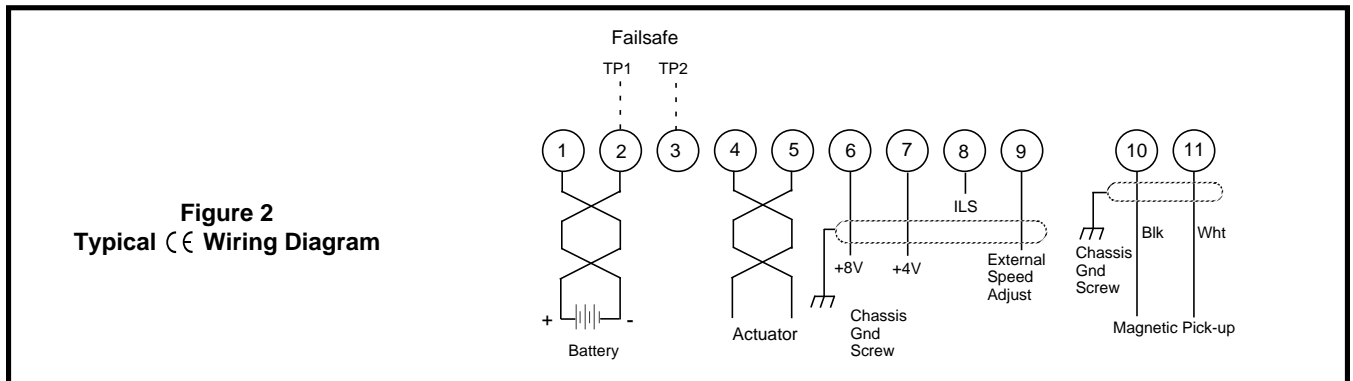

Figure 2
Typical CE Wiring Diagram

Linear Troubleshooting Chart for DYN1-1075X Controllers

1. PROBLEM: SYSTEM IS COMPLETELY DEAD. ACTUATOR LEVER STAYS AT MINIMUM.

Means of Detection		Corrective Action
1.1	Check for battery voltage at controller on terminals 1 and 2. Terminal 1 is positive.	Check battery connections and contacts for turning power "ON" to the controllers.
1.2	Check for proper linkage set up.	Correct and free linkage.
1.3	Magnetic pickup signal absent or too low. Measure AC volt across terminals 10 & 11 while cranking the engine. Voltage should be at least 2.5 VAC. NOTE: The voltmeter should have an impedance of 5000 ohms/volts or higher.	Check pole tip gap over gear tooth. It should be $0.37 \pm 0.127\text{mm}$ ($0.015" \pm 0.005"$) or adjusted to obtain 2.5 VAC or greater. Verify magnetic pickup wiring.
1.4	Measure the resistance of the magnetic pickup coil. This should be from 150 ohms (250 ohms max).	If there is an open or shorted coil, replace the magnetic pickup.
1.5	Measure the resistance of each pin to the metal case of the magnetic pickup. No continuity should be evident.	If there is continuity to case, replace the magnetic pickup.
1.6	DC SUPPLY OFF. Place an insulated jumper between terminals 2 & 3 (TP1 & TP2). With DC "ON" the actuator should go to full stroke. DC voltage at terminals 4 & 5 should be within 3 volts of the supply.	If the actuator still does not move to full stroke, continue with steps below.
1.7	Measure actuator coil resistance: <ul style="list-style-type: none"> • 12 VDC unit. Coil resistance 1.8 ± 0.2 ohms. • 24 VDC unit. Coil resistance 7.3 ± 1.0 ohms. 	If actuator coil is open or shorted to case, replace actuator. If governor still does not operate, continue with steps below.
1.8	Measuring the resistance of each coil lead to the actuator case should indicate an open circuit on a low scale of the ohm meter.	If continuity is detected, replace the actuator.
1.9	With the DC to the governor "ON" and the engine "OFF" measure the DC voltage from terminal 6 (+) to 2 (-). This should be approximately 8 VDC.	If 8 VDC is not present, replace the controller.
1.10	Between terminal 7 (+) to 2 (-), the voltage should be approximately 4 VDC.	If 4 VDC is not present, replace the controller.
1.11	The following should be found when measuring current in series with one of the actuator leads from terminal 4 or 5: 12 V Act. - 2.5A to 5.9A 24 V Act. - 1.0A to 3.0A (Values may indicate negative if polarity of meter reversed.)	If no output current, replace the controller.

2. PROBLEM: ACTUATOR LEVER GOES TO FULL STROKE WHEN DC POWER IS TURNED "ON" (ENGINE IS NOT OPERATING.)

Means of Detection		Corrective Action
2.1	Check magnetic pickup leads for proper shielded wire or open shield.	Verify and correct wiring as necessary.
2.2	Be sure there is no jumper between terminals 2 & 3.	Verify and correct wiring as necessary.
2.3	Fail-safe circuit in the controller may be damaged or defective.	Replace controller.
2.4	With DC power "OFF" remove leads at actuator. Check continuity of each terminal to case. There should be no continuity between any terminal and case of the controller.	If continuity is detected, replace the controller.
2.5	Check for shorted actuator lead.	Correct or replace actuator leads as necessary.
2.6	If remote speed potentiometer has been connected to terminals 6, 7 and 8, or 9 of the controller, DISCONNECT THESE LEADS.	Turn DC power "ON" to the governor if the actuator is now normal. Proceed as follows.

3. PROBLEM: IMPROPER OPERATION WITH REMOTE SPEED POTENTIOMETER CONNECTED

Means of Detection		Corrective Action
3.1	Investigate wiring to remote speed potentiometer for open or shorted circuits.	Check wiring.
3.2	If the leads at terminals 6 & 7 to the remote speed potentiometer are reversed, speed control by the remote speed potentiometer will be reversed.	Correct wiring.
3.3	Lead wire to remote speed setting potentiometer should be 3-wire shielded cable.	Verify that the drain shield wire is isolated from ground at the potentiometer.
3.4	If terminal 7 lead to the remote speed potentiometer is open, engine speed will go high.	Correct the wiring.
3.5	If wiper lead to remote potentiometer is open, there will be no control by the remote speed potentiometer.	Verify and correct wiring.
3.6	If terminal 6 lead to the clockwise terminal of the remote speed potentiometer is open, speed will remain at the value set in the controller.	Verify and correct wiring.

4. PROBLEM: ERRATIC GOVERNOR OPERATION

Means of Detection		Corrective Action
4.1	Measure DC voltage at 1 & 2 on controller terminal strip. Nominal battery voltage should be indicated.	If nominal voltage is present, wiring is correct.
4.2	Battery voltage must be 80% or greater for governor to operate.	Check battery and charging system.
4.3	RFI noise due to incorrect shielding.	Correct wiring per applicable wiring diagram.
4.4	RFI noise fed through power supply leads.	Connect twisted pair power leads direct to the battery.

5. PROBLEM: SLOW, SMALL AMPLITUDE, HUNTING OF SPEED OR FREQUENCY

Means of Detection		Corrective Action
5.1	Sticking or very loose linkage.	Correct linkage.
5.2	Improper linkage arrangement. (Stroke too short or improper.)	See installation information.

6. PROBLEM: FAST OSCILLATION OF GOVERNOR LINKAGE

Means of Detection		Corrective Action
6.1	Verify calibration settings of the controller.	Readjust settings.

7. PROBLEM: ENGINE WILL NOT START — ACTUATOR AT FULL STROKE DURING CRANKING

Means of Detection		Corrective Action
7.1	Make sure fuel is available. Air may be trapped in fuel line. Try to operate engine manually.	Check fuel to engine and check for correct wiring to shut downs.

**Barber-Colman Company
Aerospace & Power Controls Division
DYNA Product Group**

1354 Clifford Avenue Telephone (815) 637-3000
P.O. Box 2940 Facsimile (815) 877-0150
Loves Park, IL 61132-2940
United States of America

In Europe contact: Barber-Colman GmbH
Am Neuen Rheinhafen 4, D-67346 Speyer, Germany
Telephone 06232 29903, Facsimile 06232 299155

In Japan contact: Ranco Japan Ltd.
Shiozaki Bldg. 7-1, 2-chome, Hirakawa-Cho, Chiyoda-Ku
Tokyo 102, Japan
Telephone 3261 4293, Facsimile 3264 4691,

NOTE

Barber-Colman believes that all information provided herein is correct and reliable and reserves the right to update at any time. Barber-Colman does not assume any responsibility for its use unless otherwise expressly undertaken.

CAUTION

As a safety measure, the engine should be equipped with an independent overspeed shutdown device in the event of failure which may render the governor inoperative.



PRODUCT SERIES: DPG-2100

***DYNA Programmable Governor for Isochronous Generators
Calibration and Troubleshooting for DPG-2101, DPG-2102, DPG-2103, DPG-2104***



DPG-2100

The DPG-2100 governors are state of the art digital controllers. The controller can be used on both diesel and gas engines. The DPG-2100 series eliminates the need to have multiple controllers on the shelf. The governor can operate over a frequency range of 1000 to 11,000Hz, and over a nominal voltage range of 9 to 30 VDC

Actuators: DYNA 2000
DYNA 2500
Power Flows
DYNA 7000
DYNA 70025

Low Cost

User Friendly/Operator Adjustable

.25% Precision Frequency Control

Superior Temperature Stability

Reverse Battery Protection

9 - 30 VDC Input Voltage Range

Barber-Colman

Dyna
Products

**Barber-Colman
DYNA Products**
P.O. Box 2940
1354 Clifford Avenue
Loves Park, IL 61132
USA

Tel: (815) 637-3000
Fax: (815) 877-0150
www.dynaproducts.com

In Japan -
Ranco Japan
Shiozaki Bldg. 7-1
2-chome
Hirakawa-Cho, Chiyoda-Ku
Tokyo, 102, Japan

Tel: (81) 3 3261-4293
Fax: (81) 3 3264-4691

Table of Contents

1.0 INTRODUCTION	3
2.0 SPECIFICATIONS	3
3.0 USER INTERFACE	3 - 4
4.0 USER ADJUSTABLE PARAMETERS	4
5.0 SET SPEED AND GAIN SETTINGS	4
6.0 CALIBRATION	5
7.0 INTEGRAL LIMIT SETTING	6
8.0 ADJUSTING INTEGRAL LIMIT.	6
9.0 WIRING.	7
10.0 TROUBLESHOOTING.	8

1.0 INTRODUCTION

The DPG-2100 is a very versatile controller that provides 0.25% frequency control with superior temperature stability compared to an analog controller.

1.1 General Information

Engine governing is adjustable over a wide range of engine set speeds. An engine's set speed, also known as its target speed, can be any frequency from 1,000 Hertz to 11,000 Hertz. The following formula shows the relationship between engine RPM and Hertz.

$$(\text{MPU signal in Hertz}) = \frac{(\text{Engine RPM}) \times (\# \text{ of Flywheel Teeth})}{60 \text{ sec}}$$

A magnetic pickup or MPU provides the engine speed signal to the controller in Hertz. The controller compares this signal to the user programmed set speed, also in Hertz, to determine whether fuel to the engine needs to increase or decrease in order for the engine speed to equal the target speed.

The fuel flow is controlled with an actuator. The actuator may be part of a throttle body or connected to a separate throttle body with mechanical linkage. The controller provides a drive signal to the actuator to cause more or less fuel to flow through the throttle body thus affecting the engine's speed.

1.2 Actuator Compatibility

Actuators:

- DYNA 2000
- DYNA 2500
- Power Flows
- DYNA 7000
- DYNA 70025

2.0 SPECIFICATIONS

Operating Voltages:

9 VDC minimum to 30 VDC maximum

Maximum output current: 7 amps continuous,

14 amps ten seconds maximum

Steady State Speed Band: ± .25% over temperature range of -40°F to +180°F, -40°C to +85°C

Ambient Operating Temperature:

-40°F to +180°F, -40°C to +85°C

Sealing: Oil, water, and dust resistant via conformal coating and die cast enclosure

Connections: Euro-style terminal strip

Weight: .6lbs, .28kilograms

Input signal: 0-1000 Hz startup

1000-11,000 Hz normal operation

Mechanical Vibration: Suitable for mounting per SAE J1455; 1 to 500Hz, 5G amplitude

Input signal frequency from mag pickup:

Freq. (HZ) = (Engine rpm * flywheel teeth) ÷ 60 sec.

Controller Adjustment: Set speed using increase/decrease pushbuttons and Gain (270 degree adjustment)

Temperature Stability: .007 Hz @ 70°C

Input signal voltage from mag pickup:

2.5 VAC RMS minimum during cranking

Models (Replaces):

DPG-2101 (DYN1-1070x)

DPG-2102 (DYN1-1072x)

DPG-2104 (DYN1-1078x)

Diagnostic LED:

Off - no power or reverse battery exists

1Hz - power on

3Hz - receiving speed signal

On - service required

3.0 USER INTERFACE

The DPG-2100 provides two buttons for adjusting the engine set speed or selecting a setup mode:

3.1 Keypad

- INC - is used to increase the set speed
- DEC - is used to decrease the set speed
- Pressing INC and DEC at the same time and holding them for at least 5 seconds is done to switch between GAIN ADJUST MODE and INTEGRAL LIMIT ADJUST MODE. These modes are explained in the following sections.

NOTE: Whenever power is first applied to a controller that is off, it starts up in GAIN ADJUST MODE.

The DPG-2100 provides a potentiometer, labeled GAIN, used for two separate adjustments:

- Overall gain setting adjustments, or
- Integral limit setting adjustments.

3.2 LED

The LED (Light Emitting Diode) is used as a status and operating mode indicator.

- When the LED is off, it indicates that one of the following is true:
 - Not currently being powered.
 - Reverse powered (check polarity of supplied power).
 - Detecting an errorIf a voltage between 9 volts DC and 30 volts DC is being properly supplied across the BAT+ and BAT- terminals of the controller and the LED is off then refer to the troubleshooting section.
- A slow blinking LED indicates all of the following:
 1. The unit is powered.
 2. The unit is in the GAIN ADJUST MODE (the gain setting can be adjusted).
 3. There is no MPU (Magnetic Pick-Up) signal. This means the engine is not running. If the engine is running and the LED is blinking slow then refer to the troubleshooting section for help in diagnosing why the MPU signal to the controller is missing.
- A fast blinking LED indicates all of the following:
 1. The unit is powered.
 2. The unit is in the GAIN ADJUST MODE (the gain setting can be adjusted).
 3. There is an engine speed signal at the controller's MPU terminals.
- When the LED is on and not blinking it indicates the following:
 1. The unit is powered.
 2. The unit is in INTEGRAL LIMIT ADJUST MODE. The integral limit setting can be adjusted. In this operating mode it is not evident from the LED whether the engine is running or not.

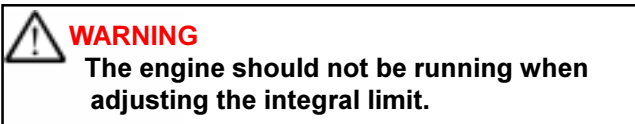

NOTE: The slow blink rate = ½ Hertz (the LED is turned on for 1 second followed by off for 1 second then on again and so on). The fast blink rate is 3 times faster than the slow blink rate.

4.0 USER ADJUSTABLE PARAMETERS

Parameter	Factory Setting	Minimum Setting	Maximum Setting
Set Speed	1,000 Hertz	1,000 Hertz	11,000 Hertz
Gain	20%	1%	100%
Integral Limit	75%	20%	100%

The following sections describe how to adjust these parameters as needed.

5.0 SET SPEED AND GAIN SETTINGS

The SET SPEED and GAIN adjustments work together. These adjustments are made while the engine is running.

NOTE: The factory setting for the SET SPEED is 1000 Hertz. The factory setting for the GAIN potentiometer is 20%.

The INC and DEC buttons are active whenever the controller is powered. The set speed is increased using the INC button. A momentary INC button press and release will increase the set speed by 1 Hertz. Press and hold the INC button to increase the set speed rapidly. The set speed is decreased using the DEC button.

The gain adjustment is used to modify how fast the controller responds to engine speed changes due to changing loads on the engine. Higher gain settings are more sensitive to changes in engine speed than are lower gain settings. Gain settings too high or too low can hinder the controller's ability to maintain a steady engine speed at the set speed.

As a general rule low set speeds require low gain settings. Likewise, higher set speeds require higher gain settings. For example: A set speed of 5040 Hertz will typically require a gain setting between 40% and 60% while a set speed of 3000 Hertz often works best with a gain setting between 20% and 40%.

GAIN ADJUST MODE is active when the LED is blinking either fast or slow. If the controller is powered and the LED is on and not blinking the controller is currently in INTEGRAL LIMIT ADJUST mode. To put the controller back in GAIN ADJUST MODE do one of the following:

- Turn the power to the controller off then back on, or
- Press and hold, for approximately 5 seconds, both the INC and DEC buttons until the LED starts blinking then release the buttons.

The following procedure describes how to adjust the engine set speed and the gain setting together.

6.0 CALIBRATION

The DPG-2100 is a very versatile controller. The speed range is 1000 Hz. to 11,000 Hz. The wide range of speed adjustment also has wide range of gain adjustments. The speed adjustment and gain adjustment ranges are in direct relationship with each other. Therefore, when adjusting the controller speed it will be necessary to adjust gain also.

NOTE: Controllers are factory adjusted to 1000 Hz.

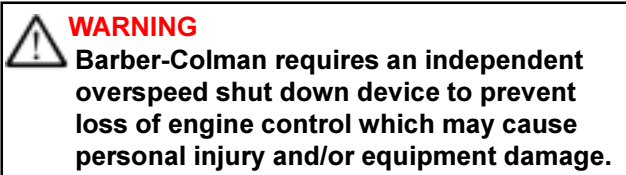

6.6 If after the engine governor has been upset, the engine begins to hunt, adjust the gain. For a slow hunt increase the gain; if the hunt is fast decrease the gain. If the engine response is slow, slowly increase the gain at ½ division increments. If the engine droops at full load, decrease the gain until the frequency is at target. When gain adjustments are made it will be necessary to recheck the performance of the engine by repeating step 5. This will help set the governor response to fuel burn rate of the engine.

- 6.1** Please read this entire procedure first before making any adjustments.
- 6.2** With no power to the governor, verify that gain is set to 20% or factory default.
- 6.3** Start the engine and adjust the speed by pressing increase/decrease speed buttons until targeted speed is achieved or engine begins to hunt. Use a customer-supplied tachometer or frequency meter to verify speed.
- 6.4** If the engine begins to hunt adjust the gain to remove the hunt. The isochronous governor holds a fixed speed. If the engine varies speed slowly (oscillation rate < 1Hz) then increase the gain (in small increments) until oscillation disappears. For a fast hunt, which is defined as a 1Hz or greater oscillation, decrease the gain in small increments. This adjustment may need to be made as engine speed is adjusted to the target speed.
- 6.5** Once the engine is set to the target speed it will be necessary to upset the engine governor to verify the performance of the system. This can be done by a very fast interruption (too long may cause shutdown) of the +MPU signal from the terminal or by bumping the linkage if available.

7.0 INTEGRAL LIMIT SETTING

The INTEGRAL LIMIT is another adjustment that is available. The integral limit setting should only be adjusted when the engine is not running.

NOTE: The factory setting for the integral limit equals 75% initially. The integral limit can be set anywhere between 20% and 100%.

The integral limit feature may be useful in minimizing engine speed overshoot related to integral windup. When the engine is unable to carry a load the integral term of the PID equation will continue to grow which can cause a delay in reducing fuel to the engine when the load is removed or reduced.

The INTEGRAL LIMIT setting is used to stop integration whenever the actuator drive signal is above a specific percentage of the maximum signal possible. In the INTEGRAL LIMIT ADJUST MODE the potentiometer is used to set the actuator drive signal percentage above which integration is stopped.

INTEGRAL LIMIT ADJUST MODE is active when the LED is not blinking and on. See the following procedure for instructions describing how to adjust the integral limit setting.

8.0 ADJUSTING THE INTEGRAL LIMIT



WARNING

The engine should not be running when adjusting the integral limit.

- 8.1 Apply power to the governor.
- 8.2 Record the current GAIN potentiometer setting.
- 8.3 Press both the DEC and INC buttons simultaneously for at least 5 seconds and the LED will stop flashing and remain turned ON.
- 8.4 The system is now in the INTEGRAL LIMIT adjust mode and the buttons can be released.
- 8.5 Turn the potentiometer to the desired position; for example to set the INTEGRAL LIMIT to 50% adjust the GAIN potentiometer to 50.
- 8.6 Press both the DEC and INC buttons simultaneously for at least 5 seconds and the LED will start flashing again.
- 8.7 The system has now been returned to the GAIN adjust mode and the buttons can be released.
- 8.8 Return the GAIN potentiometer to the setting recorded in step 3.
- 8.9 INTEGRAL LIMIT adjustment is complete.

NOTE: The INTEGRAL LIMIT is preset at the factory to 75%.

9.0 WIRING

9.1 TYPICAL WIRING DIAGRAM

General information, wiring and calibration procedure for the DPG-2100 Series controllers for the linear governor system.

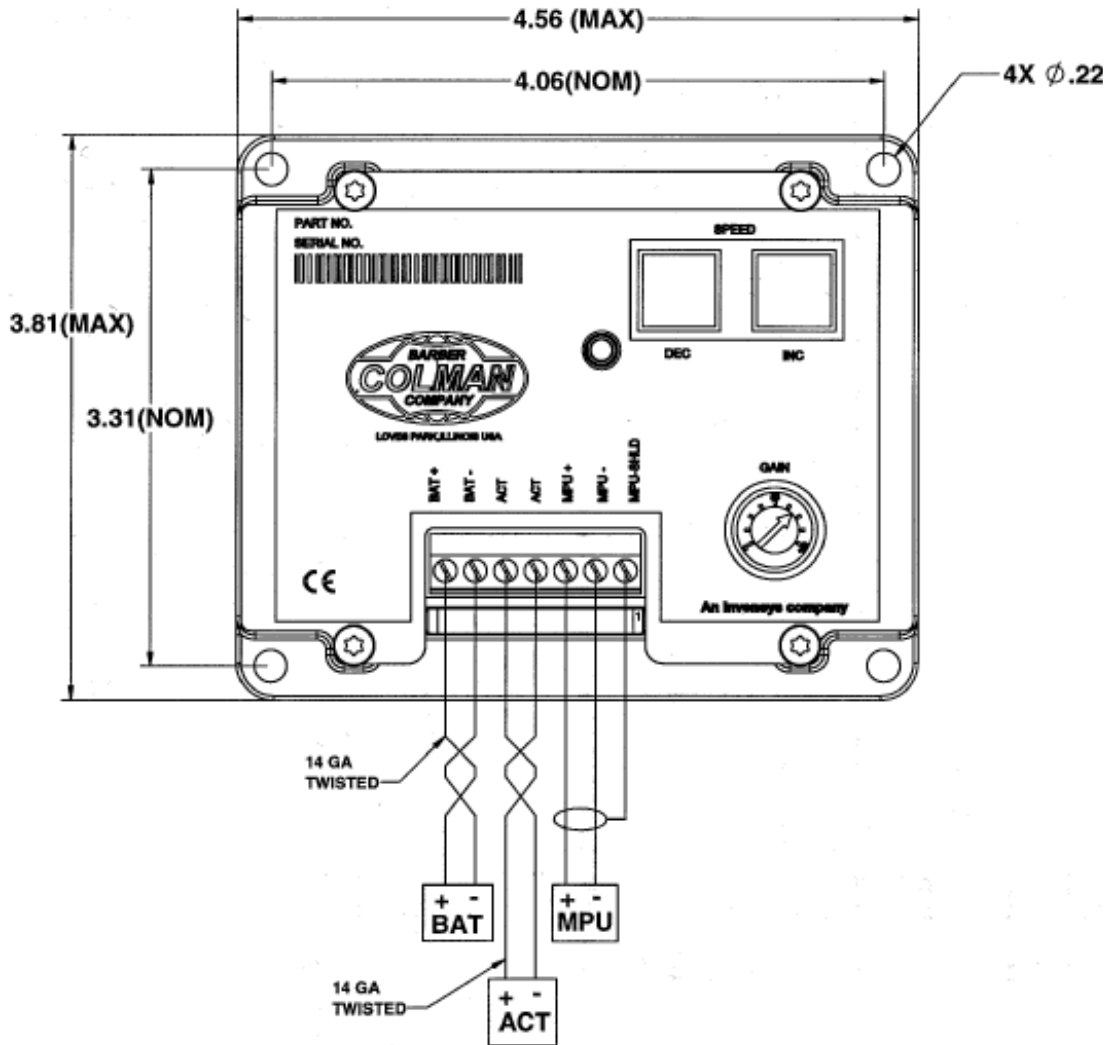

9.2 TERMINAL IDENTIFICATION

All four DPG-2100 model controllers are wired as shown in Figure 1 Wiring Diagram.

1. **BATT +** to battery positive
2. **BATT -** to battery negative
3. **ACT** to actuator lead, no polarity
4. **ACT** to actuator lead, no polarity
5. **MPU +** to positive lead of magnetic pickup
6. **MPU -** to negative lead of magnetic pickup
7. **MPU SHIELD** to drain wire

Controllers meet current CE directives for electromagnetic compliance (emc).

10.0 TROUBLESHOOTING

Normally governor LED flashes at a ½ Hz rate when CPU is functioning properly. Applying a starting speed will cause the actuator to go to full speed. LED flashes at 1 ½ Hz rate when an MPU signal is detected.

PROBLEM	DETECTION	CORRECTIVE ACTION
System appears dead. No LED, fails to move actuator.	<p>Check Battery Voltage at controller with power switch turned "ON". Measure DC battery voltage between (Bat.+ and Bat.-)</p> <p>Check polarity of the Battery + and Battery -</p>	<p>If no voltage, check connections to battery.</p> <p>Correct wiring</p>
LED blinking slow and engine being cranked.	<p>Check linkage. Manually operate linkage to see that it is not sticking or binding.</p>	Free Linkage.
	<p>No signal or weak signal from magnetic pickup. Measure AC voltage between terminals MPU + and MPU – on the controller while cranking engine. Voltage should be 2.5 volts RMS or greater. (AC input impedance of meter must be 5000 ohms.)</p>	Check for damage to or improper adjustment of magnetic pickup. Replace or readjust.
LED blinking fast but actuator does not move to open.	<p>Check Actuator output with power "on" to controller. Measure the following terminals on the controller box with respect to bat -. All points should read Battery (+/- 95%)</p> <p>A) 1. Act to Battery - = Battery voltage 2. Act to Battery - = Battery voltage (+ or - 1.5 VDC)</p> <p>B) Following checks are terminals on the actuator and battery– on the controller.</p> <p>1) Low voltage (1.0-2.0VDC) at either actuator terminal</p> <p>2) Battery voltage at both actuator connectors</p> <p>3) Battery voltage at one actuator lead but not at the other</p>	<p>Replace Controller if 95% of battery voltage is not present.</p> <p>Broken actuator lead</p> <p>Broken actuator lead</p> <p>Check actuator</p>
Actuator lever goes to full fuel whenever the power is turned "ON" and engine is not running	<p>Check controller and actuator wiring</p> <p>1) Turn power off to controller</p> <p>2) Remove wiring to actuator terminals on controller and measure resistance between each lead and chassis ground. 0.0- ohms indicates shorted leads.</p> <p>3) Normal resistance</p>	<p>Correct or replace actuator wiring.</p> <p>Replace controller because it should not cause actuator lever to go to full fuel with engine not running.</p>
Engine hunts during operation External linkage	<p>1) Linkage or rod end bearing sticking or binding.</p> <p>2) Improper linkage arrangement. (Stroke too short or improper non-linear linkage used)</p> <p>3) Improper governor adjustment</p>	<p>Lubricate or replace</p> <p>See installation information</p> <p>Readjust calibration</p>
Engine hunts during operation Internal/External linkage	<p>1) Inadequate power supply voltage.</p> <p>a) Turn power switch "OFF"</p> <p>b) Remove actuator leads from controller.</p> <p>c) Connect actuator leads to battery+ and battery- direct to battery.</p> <p>2) Actuator should go to full fuel.</p> <p>3) Internal style actuator should give a click noise when actuator hits the stops.</p> <p>4) External style actuator should be visibly in the fuel position.</p> <p>5) The actuator should go to full fuel and the DC voltage must be greater than 80% of supply.</p> <p>24 VDC @ 80% = 19.2 VDC 12 VDC @ 80% = 9.6 VDC</p> <p>Note: With the power switch in the "OFF" position when testing is completed remove actuator leads from battery and reconnect actuator leads to controller.</p>	<p>If actuator doesn't make full fuel, then check actuator leads. If voltage is less than specified, check for loose or poor connections to battery, or get larger supply leads or larger power supply.</p>



WARNING

Barber-Colman requires an independent overspeed shut down device to prevent loss of engine control which may cause personal injury and/or equipment damage.

- NOTE -

Barber-Colman believes that all information provided herein is correct and reliable and reserves the right to update at any time. Barber-Colman does not assume any responsibility for its use unless otherwise expressly undertaken.



DYNA "POWER FLOW 38"

GENERAL

The Barber-Colman PowerFlow 38 is an integrated valve actuator designed for throttling the intake of internal combustion engines. The system is designed to couple an Impco 55, 100 or 125 series mixer and a standard SAE 1-1/4" flanged intake manifold. This integrated throttle body is adaptable to a fuel injected engine for air control.

The throttle valve is a new, compact design available with and without position feedback sensor.

STANDARD FEATURES

- All Electric
- Fast Response
- Small and Compact
- Mounts in Any Position
- No Mechanical Linkage
- No Mounting Bracket
- Precise Repeatability
- Spring Return to Minimum Fuel

STANDARD MODELS

- DYNC-60000-001-0-12
- DYNC-60100-002-0-12

TYPICAL APPLICATIONS

- Speed Governing
- Generator Sets
- Forklift Trucks
- Power Carts
- Off-Road Vehicles
- Pump Sets
- Wood Chippers

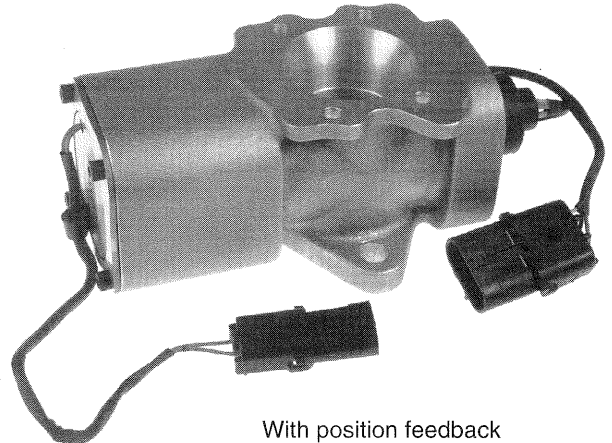

With position feedback
DYNC-60100-002-0-12

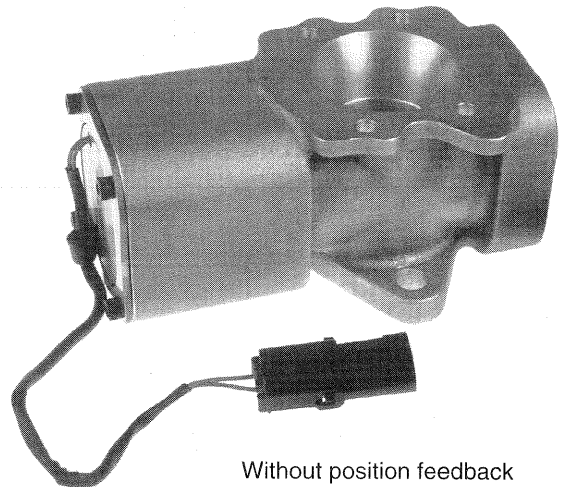

Without position feedback
DYNC-60000-001-0-12



INSTALLATION DIMENSIONS - DYNC-60000

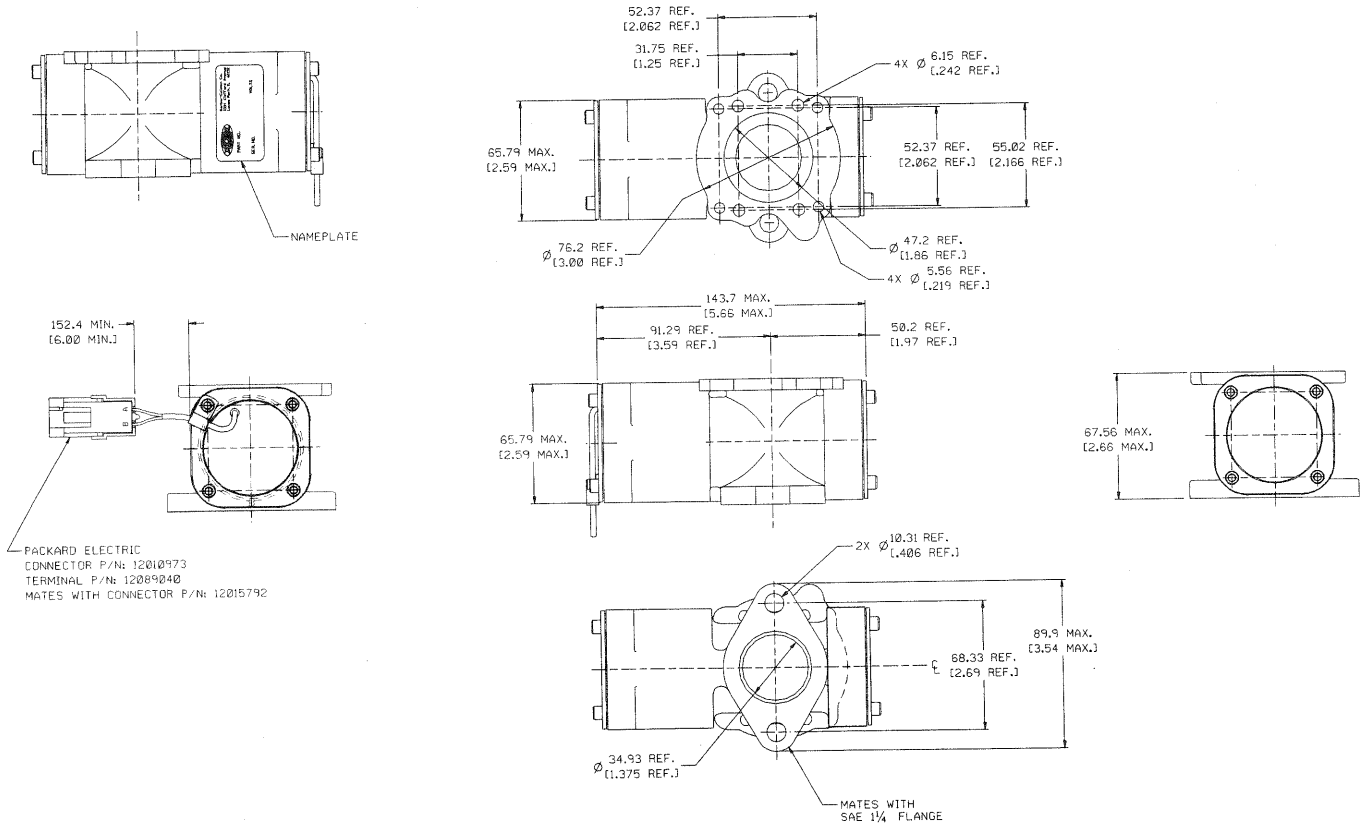

SPECIFICATIONS

Operating Voltage:	12 VDC ± 20%
Rotation:	65 degrees ± 5 degrees
Air/Fuel Flow:	202 cu. ft./min
Mounting Attitude:	Any Position
Approximate Weight:	3.5 Pounds/1.6 Kilograms
Current at 12 VDC:	Nominal Steady State Amperes: 2.1 A Maximum at Stall Amperes at 24 degrees C: 5.90 A
Operating Temperature:	-40 to 257 degrees F -40 to 125 degrees C
Mechanical Vibration	Per MIL-STD-810C 5-500 Hz Curve L
Sealing:	Unit is oil and dust resistant
Throttle Position Sensor Input Operating Voltage:	5.00 VDC ± 5% VDC
Throttle Position Sensor Output Operating Voltage:	1.00 VDC to 4.00 VDC

INSTALLATION DIMENSIONS - DYNC 60100

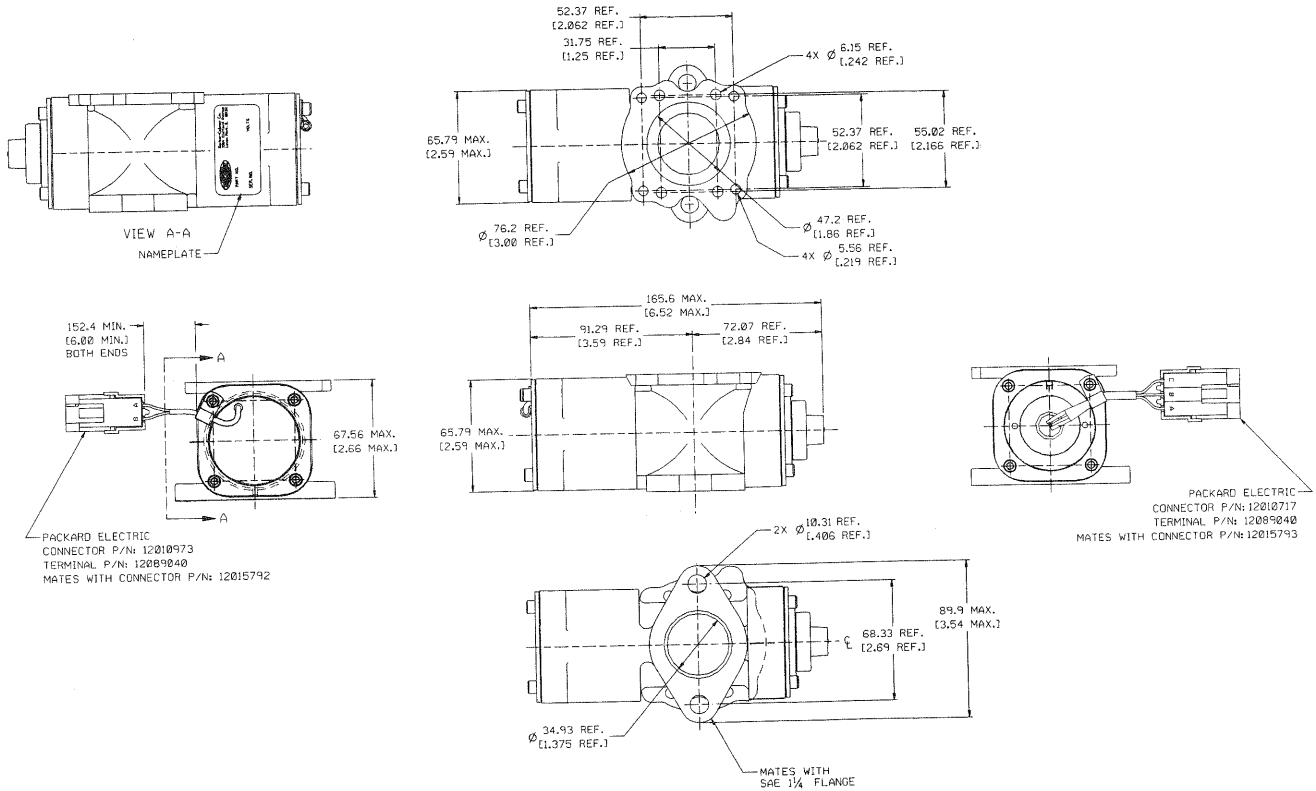

CAUTION

As a safety measure, the engine should be equipped with an independent overspeed shutdown device in the event of failure which may render the governor inoperative.

NOTE

Barber-Colman believes that all information provided herein is correct and reliable and reserves the right to update at any time. Barber-Colman does not assume any responsibility for its use unless otherwise expressly undertaken.

CAUTION

Always observe engine manufacturer's fuel and air filter requirements for the engine application. Do not operate without proper filtration.

This product is not intended for biogas applications. Do not operate with this fuel.

Power Flow 38 should only be used on naturally aspirated engines and should not be used for engine shutdown.

Barber-Colman Company
Aerospace & Power Controls Division
DYNA Product Group

1354 Clifford Avenue Telephone (815) 637-3000
P.O. Box 2940 Facsimile (815) 877-0150
Loves Park, IL 61132-2940
United States of America Website: www.dynaproducts.com

In Europe contact: Barber-Colman GmbH
Am Neuen Rheinhafen 4, D-67346 Speyer, Germany
Telephone 06232 29903, Facsimile 06232 299155

In Japan contact: Ranco Japan Ltd.
Shiozaki Bldg. 7-1, 2-chome, Hirakawa-Cho, Chiyoda-Ku
Tokyo 102, Japan
Telephone 3261 4293, Facsimile 3264 4691



CALIBRATION & WIRING FOR DYN1-10744-000-0-12

1.0 CALIBRATION PROCEDURE

- 1.1 Wire the system as shown.
- 1.2 Start the engine and adjust the speed by turning the speed potentiometer clockwise to increase speed.
- 1.3 At no load, turn the gain potentiometer clockwise until engine begins to hunt. If engine does not hunt, physically upset the governor linkage.
- 1.4 Turn the gain potentiometer counterclockwise until stable. If gain potentiometer is turned fully counterclockwise, and engine still hunts, remove wire from the controller gain change to battery negative.
- 1.5 Removing the controller gain change reduces the over-all gain by 25%. Repeat steps 1.3 through 1.6 until engine is stable.
- 1.6 Recheck engine speed and adjust the speed potentiometer accordingly.

NOTE

Controllers are factory set to minimum RPM, but for safety, it should be possible to disable the engine if overspeed should occur.



Wiring Diagram for a DYN1-10744-000-0-12

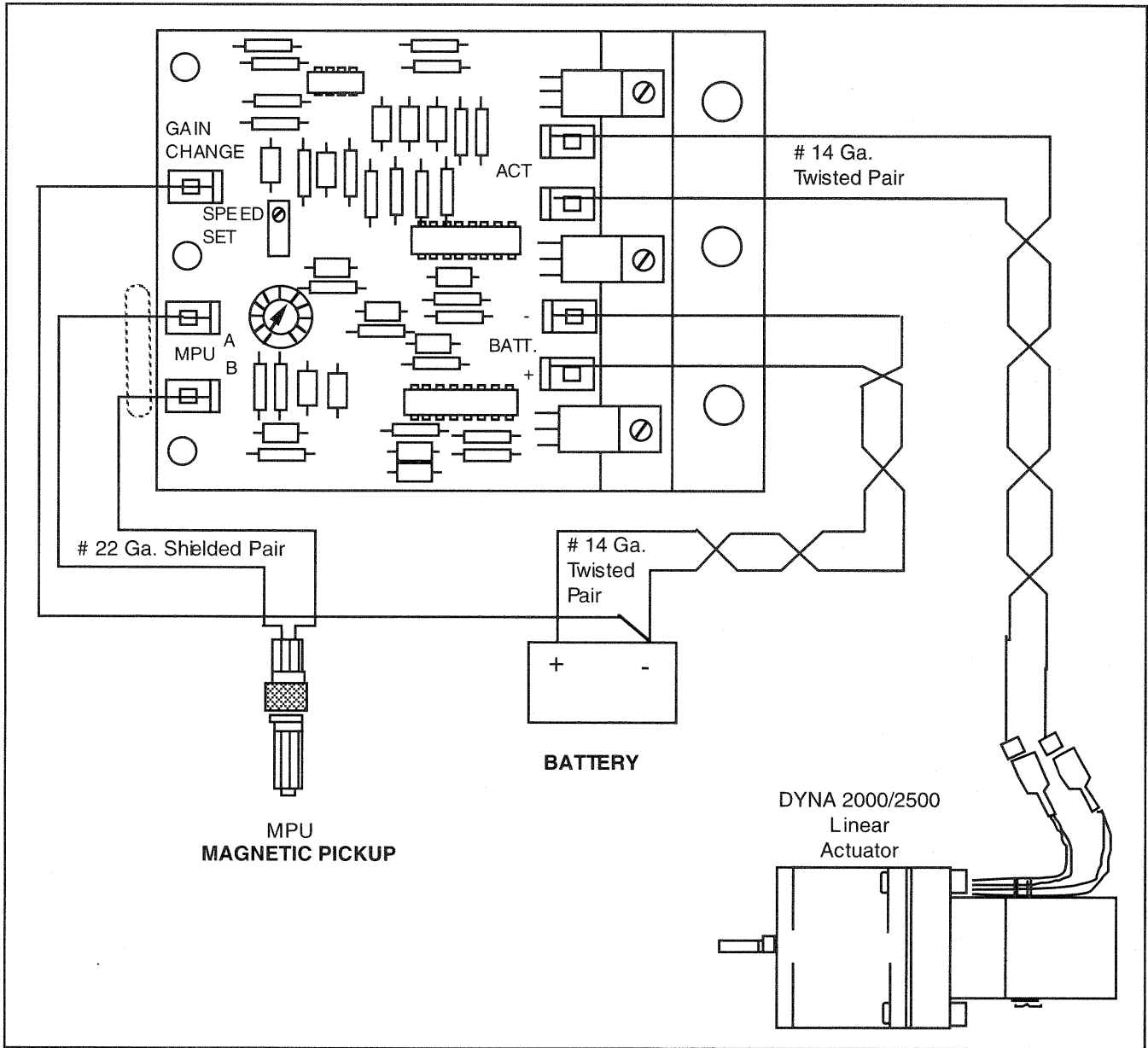

Linear Troubleshooting Chart for DYN1-10744-000-0-12

1. PROBLEM: SYSTEM IS COMPLETELY DEAD. ACTUATOR LEVER STAYS AT MINIMUM.

Means of Detection	Corrective Action
1.1 Check for battery voltage at controller on battery positive and battery negative.	Check battery connections and contacts for turning power "ON" to the controllers.
1.2 Check for proper linkage set up.	Correct and free linkage.
1.3 Magnetic pickup signal absent or too low. Measure AC volt across MPU A & B while cranking the engine. Voltage should be at least 2.5 VAC. NOTE: The voltmeter should have an impedance of 5000 ohms/volts or higher.	Check pole tip gap over gear tooth. It should be $0.37 \pm 0.127\text{mm}$ ($0.015" \pm 0.005"$) or adjusted to obtain 2.5 VAC or greater. Verify magnetic pickup wiring.
1.4 Measure the resistance of the magnetic pickup coil. This should be approximately 150 to 5000 ohms max.	If there is an open or shorted coil, replace the magnetic pickup.
1.5 Measure the resistance of each pin to the metal case of the magnetic pickup. No continuity should be evident.	If there is continuity to case, replace the magnetic pickup.
1.6 DC SUPPLY OFF. Remove actuator leads from terminals. Place actuator battery system power leads on. Actuator should go to full stroke.	If the actuator still does not move to full stroke, continue with steps below.
1.7 Measure actuator coil resistance: <ul style="list-style-type: none"> • 12 VDC unit. Coil resistance 1.4 ± 0.2 ohms. • 24 VDC unit. Coil resistance 7.3 ± 1.0 ohms. 	If actuator coil is open or shorted to case, replace actuator. If governor still does not operate, continue with steps below.
1.8 Measuring the resistance of each coil lead to the actuator case should indicate an open circuit on a low scale of the ohm meter.	If continuity is detected, replace the actuator.
1.9 While cranking the engine, the following should be found when measuring current in series with one of the actuator leads from actuator: 12 V Act. - 2.5A to 5.9A 24 V Act. - 1.0A to 3.0A (Values may indicate negative if polarity of meter reversed.)	If no output current, replace the controller.

2. PROBLEM: ACTUATOR LEVER GOES TO FULL STROKE WHEN DC POWER IS TURNED "ON" (ENGINE IS NOT OPERATING.)

Means of Detection		Corrective Action
2.1	Check magnetic pickup leads for proper shielded wire or open shield.	Verify and correct wiring as necessary.
2.2	With DC power "OFF" remove leads at actuator. Check continuity of each terminal to heat sink. There should be no continuity between any terminal and heat sink.	If continuity is detected, replace the controller.
2.3	Check for shorted actuator lead.	Correct or replace actuator leads as necessary.

3. PROBLEM: ERRATIC GOVERNOR OPERATION

Means of Detection		Corrective Action
3.1	Measure DC voltage at battery positive and battery negative on controller. Nominal battery voltage should be indicated.	If nominal voltage is present, wiring is correct.
3.2	Battery voltage must be 80% or greater for governor to operate.	Check battery and charging system.
3.3	RFI noise due to incorrect shielding.	Correct wiring per applicable wiring diagram.
3.4	RFI noise fed through power supply leads.	Connect twisted pair power leads direct to the battery.

4. PROBLEM: SLOW, SMALL AMPLITUDE, HUNTING OF SPEED OR FREQUENCY

Means of Detection		Corrective Action
4.1	Sticking or very loose linkage.	Correct linkage.
4.2	Improper linkage arrangement. (Stroke too short or improper.)	See installation information.

5. PROBLEM: FAST OSCILLATION OF GOVERNOR LINKAGE

Means of Detection		Corrective Action
5.1	Verify calibration settings of the controller.	Readjust settings.

6. PROBLEM: ENGINE WILL NOT START — ACTUATOR AT FULL STROKE DURING CRANKING

Means of Detection		Corrective Action
6.1	Make sure fuel is available. Air may be trapped in fuel line. Try to operate engine manually.	Check fuel to engine and check for correct wiring to shut downs.

Barber-Colman Company
Aerospace & Power Controls Division
DYNA Product Group

1354 Clifford Avenue
P.O. Box 2940
Loves Park, IL 61132-2940
United States of America

Telephone (815) 637-3000
Facsimile (815) 877-0150

In Europe contact: Barber-Colman GmbH
Am Neuen Rheinhafen 4, D-67346 Speyer, Germany
Telephone 06232 29903, Facsimile 06232 299155

In Japan contact: Ranco Japan Ltd.
Shiozaki Bldg. 7-1, 2-chome, Hirakawa-Cho, Chiyoda-Ku
Tokyo 102, Japan
Telephone 3261 4293, Facsimile 3264 4691,

NOTE

Barber-Colman believes that all information provided herein is correct and reliable and reserves the right to update at any time. Barber-Colman does not assume any responsibility for its use unless otherwise expressly undertaken.

CAUTION

As a safety measure, the engine should be equipped with an independent overspeed shutdown device in the event of failure which may render the governor inoperative.