

GENERAC®

POWER SYSTEMS, INC.

Owner's Manual



GTS "W" Type

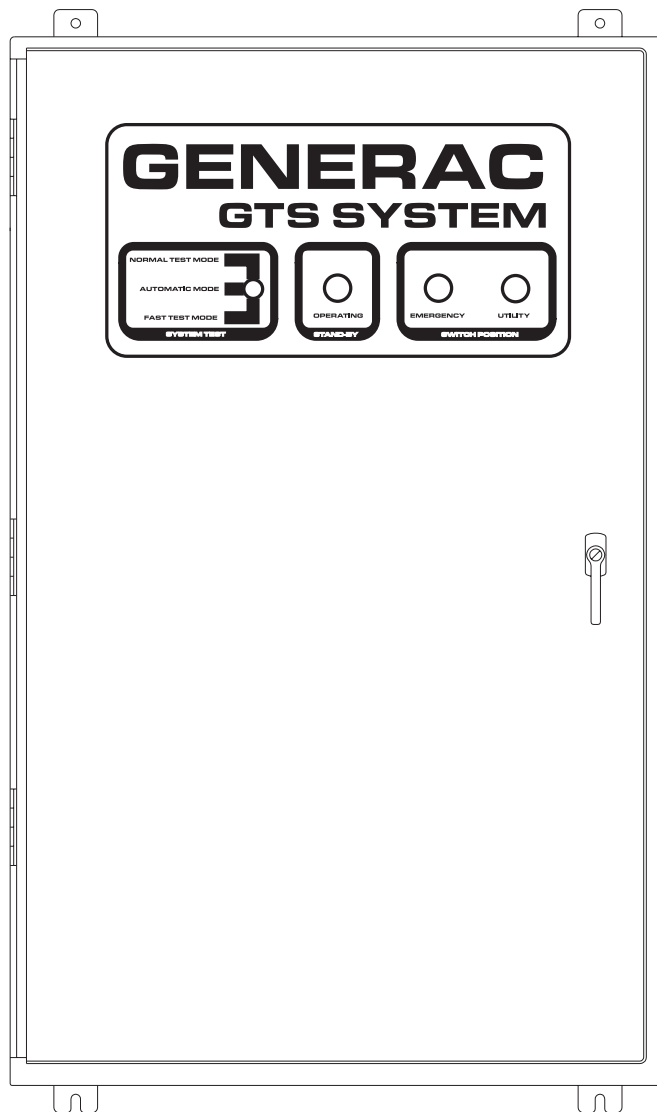

**Automatic
Transfer Switch**

100 thru 400 amp,
600 volts





 **Read the following information carefully before attempting to install, operate or service this equipment. Also read the instructions and information on tags, decals, and labels that may be affixed to the transfer switch. Replace any decal or label that is no longer legible.** 

 **DANGER! Connection of a generator to an electrical system normally supplied by an electric utility shall be by means of suitable transfer equipment so as to isolate the electric system from utility distribution system when the generator is operating (Article 701 Legally Required Standby Systems or Article 702 Optional Standby Systems, as applicable). Failure to isolate electric system by these means may result in damage to generator and may result in injury or death to utility workers due to backfeed of electrical energy.** 

Generac cannot possibly anticipate every possible circumstance that might involve a hazard. The warnings in this manual, and on tags and decals affixed to the unit are, therefore, not all-inclusive. If you use a procedure, work method or operating technique Generac does not specifically recommend, you must satisfy yourself that it is safe for you and others. You also must make sure the procedure, work method or operating technique that you choose does not render the transfer switch unsafe.

Throughout this publication, and on tags and decals affixed to the generator, DANGER, WARNING, CAUTION and NOTE blocks are used to alert you to special instruction about a particular operation that may be hazardous if performed incorrectly or carelessly. Observe them carefully. Their definitions are as follows:

—  **DANGER**  —

After this heading, you can read instructions that, if not strictly complied with, will result in personal injury or property damage.

—  **WARNING**  —

After this heading, you can read instructions that, if not strictly complied with, may result in personal injury or property damage.

—  **CAUTION**  —





After this heading, you can read instructions that, if not strictly complied with, could result in damage to equipment and/or property.

NOTE:

After this heading, you can read explanatory statements that require special emphasis.

These safety warnings cannot eliminate the hazards that they indicate. Common sense and strict compliance with the special instructions while performing the service are essential to preventing accidents.

Four commonly used safety symbols accompany the DANGER, WARNING and CAUTION blocks. The type of information each indicates follows:

-  This symbol points out important safety information that, if not followed, could endanger personal safety and/or property of you and others.
-  This symbol points out potential explosion hazard.
-  This symbol points out potential fire hazard.
-  This symbol points out potential electrical shock hazard.

 **GENERAL HAZARDS** 

- Any AC generator that is used for backup power if a NORMAL (utility) power source failure occurs, must be isolated from the NORMAL (utility) power source by means of an approved transfer switch. Failure to properly isolate the NORMAL and STANDBY power sources from each other may result in injury or death to electric utility workers, due to backfeed of electrical energy.
- Improper or unauthorized installation, operation, service or repair of the equipment is extremely dangerous and may result in death, serious personal injury, or damage to equipment and/or personal property.
- Extremely high and dangerous power voltages are present inside an installed transfer switch. Any contact with high voltage terminals, contacts or wires will result in extremely hazardous, and possibly LETHAL, electric shock. DO NOT WORK ON THE TRANSFER SWITCH UNTIL ALL POWER VOLTAGE SUPPLIES TO THE SWITCH HAVE BEEN POSITIVELY TURNED OFF.
- Competent, qualified personnel should install, operate and service this equipment. Adhere strictly to local, state and national electrical and building codes. When using this equipment, comply with regulations the National Electrical Code (NEC), CSA Standard; C22.1 Canadian Electric Code and Occupational Safety and Health Administration (OSHA) have established.
- Never handle any kind of electrical device while standing in water, while barefoot, or while hands or feet are wet. DANGEROUS ELECTRICAL SHOCK MAY RESULT.

- Because jewelry conducts electricity, wearing it may cause dangerous electrical shock. Remove all jewelry (such as rings, watches, bracelets, etc.) before working on this equipment.
- If you must work on this equipment while standing on metal or concrete, place insulative mats over a dry wood platform. Work on this equipment only while standing on such insulative mats.
- Never work on this equipment while physically or mentally fatigued.
- Keep the transfer switch enclosure door closed and bolted at all times. Only qualified personnel should be permitted access to the switch interior.
- In case of an accident caused by electric shock, immediately shut down the source of electrical power. If this is not possible, attempt to free the victim from the live conductor but **AVOID DIRECT CONTACT WITH THE VICTIM**. Use a nonconducting implement, such as a rope or board, to free the victim from the live conductor. If the victim is unconscious, apply first aid and get immediate medical help.
- When an automatic transfer switch is installed for a standby generator set, the generator engine may crank and start at any time without warning. To avoid possible injury that might be caused by such sudden start-ups, the system's automatic start circuit must be disabled before working on or around the generator or transfer switch. For that purpose, a **SAFETY DISCONNECT** is provided inside the transfer switch. Always set that switch to its **MANUAL** position before working on the equipment. Then place a "DO NOT OPERATE" tag on the transfer switch and on the generator.

Safety RulesInside Front Cover-1

Section 1 – General Information2

1.1 Introduction2

1.2 Equipment Description2

1.3 Transfer Switch Data Plate2

1.4 Transfer Switch Enclosure2

1.5 Safe Use Of Transfer Switch2

Section 2 – Installation3

2.1 Introduction to Installation3

2.2 Unpacking.....3

2.3 Mounting.....3

2.4 Connecting Power Source and Load Lines3

2.5 Connecting Start Circuit Wires4

2.6 Auxiliary Contacts5

2.7 Time Delay Neutral On-Off Switch6

2.8 Optional Accessories6

Section 3 – Operation6

3.1 Functional Tests & Adjustments6

3.2 Manual Operation6

3.3 Voltage Checks7-8

3.4 Electrical Operation8-9

3.5 Transfer Mechanism9

3.6 Main Contacts at Normal (Utility)9

3.7 Main Contacts at Neutral9

3.8 Main Contacts at Standby (Emergency)9-10

3.9 Switches and Advisory Lamps10

3.10 System Test Switch10

3.11 Standby-Operating Light10

3.12 Switch Position Light10

3.13 Sequence of Operation10-11

3.14 Sequence of Operation Settings12

3.15 Transfer Switch Options13-14

3.16 Sensor and Timer Adjustments - Sensing Circuit Board14

3.17 Adjustments On Inphase Monitor Control Circuit Board14-16

3.18 Calibrating the Inphase Monitor Control Circuit Board16-17

3.19 Circuit Board Switch SW117

3.20 Adjustments On 7-Day Exerciser Circuit Board18

3.21 Optional Deluxe Exercise Circuit Board Settings18

3.22 Calibrate Utility Voltage Sensing Circuit Board18-19

Section 4 – Maintenance.....19

4.1 Operate Transfer Switch19

4.2 Clean and Inspect Transfer Switch19

4.3 7-Day Exerciser19

4.4 Lubrication19

4.5 Main Current Carrying Contacts19

4.6 Nine-Volt Battery19

Section 5 – Mounting Dimensions20-22

Section 6 – Wiring Diagrams & Electrical Schematics23-32

Section 7 – Exploded Views & Parts Lists.....33-38

Section 8 – Notes39-41

Section 9 – WarrantyBack Cover

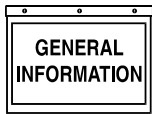

1.1 INTRODUCTION

This manual has been prepared especially for the purpose of familiarizing personnel with the design, application, installation, operation and servicing of the applicable equipment. Read the manual carefully and comply with all instructions. This will help to prevent accidents or damage to equipment that might otherwise be caused by carelessness, incorrect application, or improper procedures.

Every effort has been expended to make sure that the contents of this manual are both accurate and current. Generac, however, reserves the right to change, alter or otherwise improve the product at any time without prior notice.

1.2 EQUIPMENT DESCRIPTION

The automatic transfer switch is used for transferring critical electrical load from a NORMAL (utility) power source to a STANDBY (emergency generator) power source. Such a transfer of electrical loads occurs automatically when the NORMAL power source has failed or is substantially reduced and the STANDBY source voltage and frequency have reached an acceptable level. The transfer switch prevents electrical feedback between two different power sources (such as the NORMAL and STANDBY sources) and, for that reason, codes require it in all standby electric system installations.

The transfer switch consists of a solid state intelligence circuit, a transfer mechanism and a control panel.

1.3 TRANSFER SWITCH DATA PLATE

A DATA PLATE is permanently affixed to the transfer switch enclosure. Use this transfer switch only with the specific limits shown on the DATA PLATE and on other decals and labels that may be affixed to the switch. This will prevent damage to equipment and property.

When requesting information or ordering parts for this equipment, make sure to include all information from the DATA PLATE.

Record your Model and Serial numbers in the space provided below for future reference.

MODEL #
SERIAL #

1.4 TRANSFER SWITCH ENCLOSURE

The standard switch enclosure is a National Electrical Manufacturer’s Association (NEMA) 1 type. NEMA 1 type enclosures primarily provide protection against contact with the enclosed equipment and against a limited amount of falling dirt.

1.5 SAFE USE OF TRANSFER SWITCH

Before installing, operating or servicing this equipment, read the SAFETY RULES (inside front cover) carefully. Comply strictly with all SAFETY RULES to prevent accidents and/or damage to the equipment. Generac recommends you make a copy of the SAFETY RULES and post them near the transfer switch. Also, be sure to read all instructions and information you may find on tags, labels and decals affixed to the equipment.

Two publications that outline the safe use of transfer switches are the following:

- National Electrical Code
- UL 1008, STANDARD FOR SAFETY-AUTOMATIC TRANSFER SWITCHES

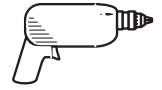

2.1 INTRODUCTION TO INSTALLATION

This equipment has been wired and tested at the factory. Installing the switch includes the following procedures:

- Mounting the enclosure.
- Connecting power source and load leads.
- Connecting the generator start circuit.
- Connecting any auxiliary contact (if needed)
- Installing/connecting any options and accessories.
- Testing functions.

2.2 UNPACKING

Carefully unpack the transfer switch. Inspect closely for any damage that might have occurred during shipment. The purchaser must file with the carrier any claims for loss or damage incurred while in transit.

Check that all packing material is completely removed from the switch prior to installation.

Attach any lifting device to the transfer switch mounting holes or brackets only. **DO NOT LIFT THE SWITCH AT ANY OTHER POINT.**

2.3 MOUNTING

Mounting dimensions for the transfer switch enclosure are in this manual. Enclosures are typically wall-mounted. Components are generally mounted in a standard NEMA 1-type enclosure. A NEMA 12, 3R, 4 & 4X are also available. See TRANSFER SWITCH OPTIONS, Section 3.15.



Handle transfer switches carefully when installing. Do not drop the switch. Protect the switch against impact at all times, and against construction grit and metal chips. Never install a transfer switch that has been damaged.

Install the transfer switch as close as possible to the electrical loads that are to be connected to it. Mount the switch vertically to a rigid supporting structure. To prevent switch distortion, level all mounting points. If necessary, use washers behind mounting holes to level the unit.

2.4 CONNECTING POWER SOURCE AND LOAD LINES



Make sure to turn OFF both the normal (Utility) and standby (generator) power supplies before trying to connect power source and load lines to the transfer switch. Supply voltages are extremely high and dangerous. Contact with such high voltage power supply lines causes extremely haz-

ardous, possibly lethal, electrical shock.

Wiring diagrams and electrical schematics are provided in this manual. Power source and load connections are made at a transfer mechanism, inside the switch enclosure.

◆ 2.4.1 2-POLE MECHANISM

This switch (Figure 2.1) is used with a single phase system, when the single phase NEUTRAL line is to be connected to a Neutral Lug and is not to be switched.

Figure 2.1 — Typical 2-Pole Transfer Mechanism (100 Amp Shown)

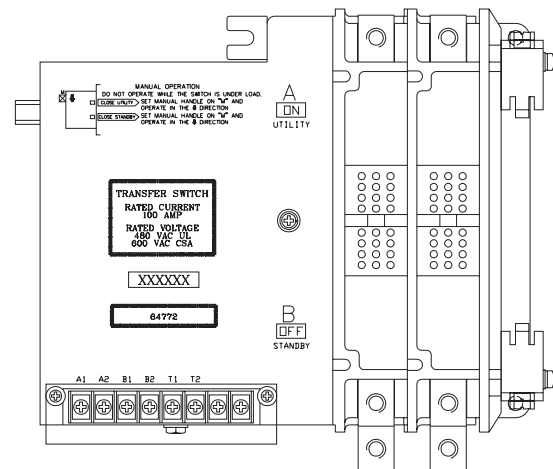

◆ 2.4.2 3-POLE MECHANISM

This switch (Figure 2.2) is used with a single phase system, when the single phase NEUTRAL line is to be switched during transfer; or with a 3-phase system, when NEUTRAL is not to be switched.

Figure 2.2 — Typical 3-Pole Transfer Mechanism (200 Amp Shown)

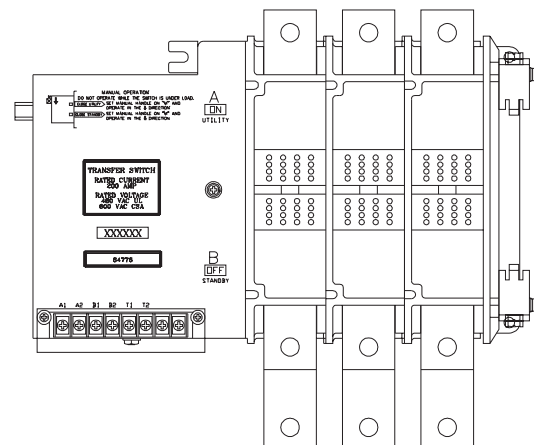

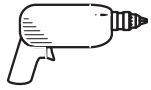

◆ 2.4.3 4-POLE MECHANISM

This switch (Figure 2.3) is used with a 3-phase system, when the NEUTRAL line is to be switched during transfer action.

Figure 2.3 — Typical 4-Pole Transfer Mechanism (400 Amp Shown)

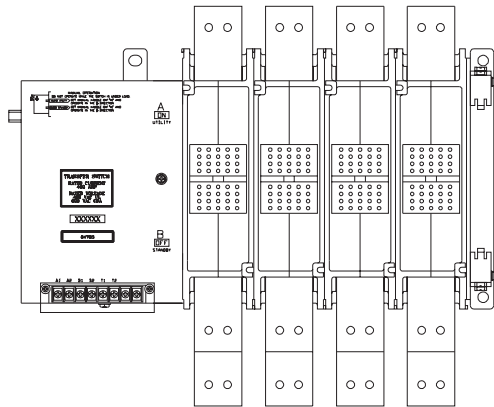

⚠ **DANGER** ⚠



All power voltage supplies must be turned off before attempting to connect power source and load lines. Failure to turn off power voltage supplies will result in extremely dangerous and possibly lethal electrical shock.

All power cables should enter the switch next to the transfer mechanism terminals. Standard terminal lugs on the transfer mechanism are solderless, screwtype.

Connect power source and load conductors to clearly marked terminal lugs on transfer mechanism as follows:

- LOAD leads: Connect to terminals T1, T2, T3, & T4*.
- NORMAL (utility) Source Leads: To terminals N1, N2, N3, & N4*.
- STANDBY (emergency) Source Leads: Connect to transfer mechanism terminal lugs E1, E2, E3, & E4*.

* The connection diagram (Figure 2.4) shows a typical 3-phase installation without switched neutral. T4, N4, and E4 are not used.

NOTE:

Unless otherwise specified, a NEUTRAL block is not supplied with transfer switch on single phase, 3-pole units where the NEUTRAL line is to be switched during transfer action. Similarly, a NEUTRAL block is not supplied on 3-phase, 4-pole units where the NEUTRAL line is to be switched during transfer.

Solderless, screw-type terminal lugs are standard. Conductor sizes must be adequate to handle the maximum current to which they will be subjected; based on the 75°C column of tables, charts, etc. used to size conductors. The installation must comply fully with all applicable codes, standards and regulations.

Before connecting wiring cables to terminals, remove any surface oxides from the cable ends with a wire brush. If ALUMINUM conductors are used, apply corrosion inhibitor to conductors. After tightening terminal lugs, carefully wipe away any excess corrosion inhibitor.

Tighten terminal lugs to the torque values as noted inside the transfer switch door.

⚠ CAUTION ⚠



Use a torque wrench to tighten the conductors, being sure not to overtighten, or damage to the switch base could occur. If undertightened, a loose connection would result, causing excess heat which could damage the switch base.

Be sure to maintain proper electrical clearance between live metal parts and grounded metal. Allow at least 1/2 inch for 100-400 amp circuits; at least 1 inch for circuits over 400 amps.

2.5 CONNECTING START CIRCUIT WIRES

Connect suitable, approved wiring to transfer switch terminals 178 and 183 (see chart below). Route these wires through suitable, approved conduit and connect to identically numbered terminals in the AC connection (lower) panel of Generac power systems (engine-generator set). See Figure 2.4.

Closure of Wire 178/183 circuit by switch circuit action must result in generator engine cranking and startup.

NOTE:

The preceding applies to the standard 2-WIRE START SYSTEM. If a generator having a 3-WIRE START SYSTEM is to be installed, using the optional 3-WIRE START SYSTEM. See TRANSFER SWITCH OPTIONS, Section 3.15.

Recommended wire gauge sizes for this wiring depends on the length of the wire, as recommended below:

MAXIMUM WIRE LENGTH	RECOMMENDED WIRE SIZE
460 feet (140m)	No. 18 AWG.
461 to 730 feet (223m)	No. 16 AWG.
731 to 1,160 feet (354m)	No. 14 AWG.
1,161 to 1,850 feet (565m)	No. 12 AWG.

Figure 2.4 — Connection Diagram - 3-Phase With Neutral Shown (Typical)

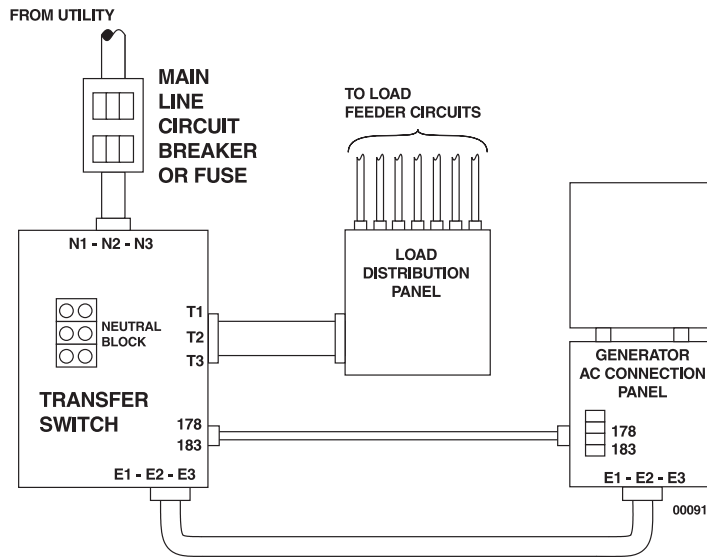

2.6 AUXILIARY CONTACTS

If desired, you have access to Auxiliary Contacts on the transfer switch to operate customer accessories, remote advisory lights, or remote annunciator devices. A suitable power source must be connected to the COMMON (C) terminal. The contacts shown as FACTORY in Figure 2.5 are connected at the factory for operating transfer switch advisory lights. The contacts shown as auxiliary are available for customer use.

Contact operation is shown in the following chart:

	Switch Position	
	Utility	Standby
Common to Normally Open	Closed	Open
Common to Normally Closed	Open	Closed

NOTE:

Auxiliary Contacts are rated 10 amps at 125 or 250 volts AC. DO NOT EXCEED THE RATED VOLTAGE AND CURRENT OF THE CONTACTS.

Figure 2.5 — Auxiliary Contact Diagram

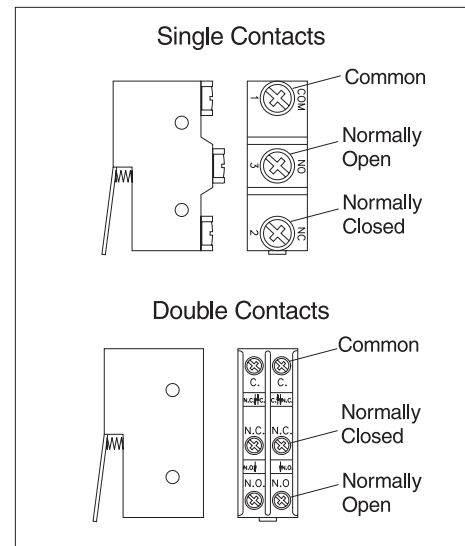
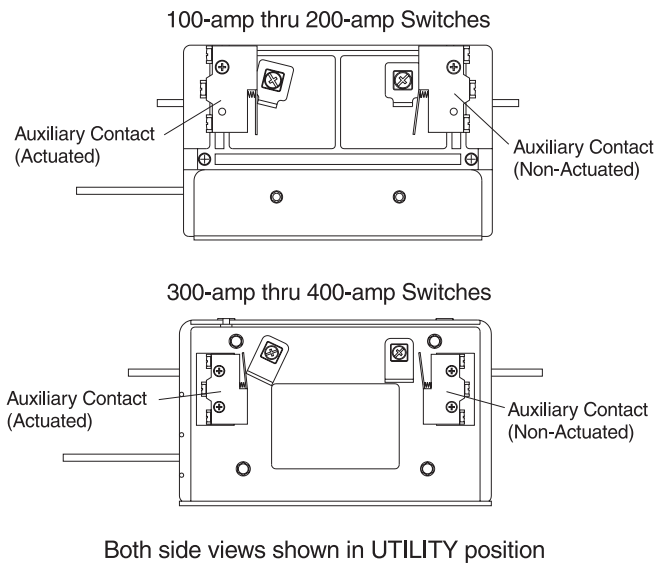

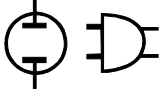

2.7 TIME DELAY NEUTRAL ON-OFF SWITCH

The Time Delay Neutral feature extends the time that the main contacts normally disconnect. By permitting the LOAD to remain disconnected from both power sources for a fixed time setting, residual voltages generated by heavy inductive loads will decay to a safe level before reconnecting. This provides some protection against nuisances such as blown fuses or circuit breakers that otherwise might occur during a rapid transfer of motor and other heavy inductive loads.

Units with the Time Delay Neutral feature are equipped with a Time Delay On/Off switch. To eliminate the time delay at neutral during a transfer action, set the switch to OFF.

Figure 2.6 — Time Delay Neutral Switch

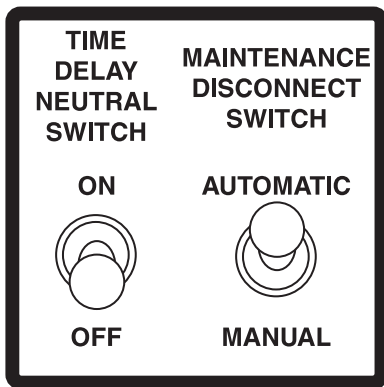

2.8 OPTIONAL ACCESSORIES

Note any optional accessories that may be installed on the transfer switch or are to be installed in the standby electric system in conjunction with the switch. Complete the necessary connections for these accessories.

3.1 FUNCTIONAL TESTS AND ADJUSTMENTS

Following transfer switch installation and interconnection, inspect the entire installation carefully. A competent, qualified electrician should inspect it. The installation should comply strictly with all applicable codes, standards, and regulations. When absolutely certain the installation is proper and correct, complete a functional test of the system. Perform functional tests in the exact order presented in this manual, or you could damage the switch.

IMPORTANT: Before proceeding with functional tests, read and make sure you understand all instructions and information in this section. Also read the information and instructions of labels and decals affixed to the switch. Note any options or accessories that might be installed and review their operation.

3.2 MANUAL OPERATION



Do NOT manually transfer under load. disconnect transfer switch from all power sources by approved means, such as a main circuit breaker(s).

A manual HANDLE is shipped with the transfer switch. Manual operation must be checked BEFORE the transfer switch is operated electrically. To check manual operation, proceed as follows:

1. In the transfer switch enclosure, set the Safety Disconnect switch to MANUAL. This prevents the generator from starting automatically as soon as you turn OFF the UTILITY power source.
2. If so equipped, turn the generator's Manual-Off-Auto switch to OFF.
3. Turn OFF both NORMAL and STANDBY power supplies to the transfer switch, with whatever means provided (such as the main line circuit breakers).
4. Note position of transfer mechanism main contacts by observing display windows in “A” and “B” in Figure 3.1 as follows:
 - Window “A” ON, Window “B” OFF - LOAD terminals (T1, T2, T3) are connected to NORMAL terminals (N1, N2, N3).
 - Window “A” OFF, Window “B” ON - LOAD terminals (T1, T2, T3) are connected to STANDBY terminals (E1, E2, E3).



Do not use excessive force when operating the transfer switch manually or you could damage the manual handle.

◆ 3.2.1 CLOSE TO NORMAL SOURCE SIDE

Before proceeding, verify the position of the switch by observing window “A” in figure 3.1. If window “A” reads “ON”, proceed with Step 1, and if it reads “OFF”, proceed with Step 2.

Step 1: With the handle attached to the actuating shaft, move handle in the direction of the arrow on the switch cover until it stops — DO NOT FORCE. Release handle slowly to allow the spring in the switch box to relax. “OFF” now appears in Window “A” and “ON” appears in Window “B”. (Proceed with Step 2).

Step 2: With the handle attached to the actuating shaft, move handle in the direction of the arrow on the switch cover until it stops — DO NOT FORCE. Release handle slowly to allow the spring in the switch box to relax. “ON” now appears in Window “A” and “OFF” appears in Window “B”. (Proceed with B: Close to STANDBY Source Side).

Figure 3.1 — Actuating Transfer Switch



DANGER: Do NOT manually transfer under load. Disconnect transfer switch from all power sources by approved means, such as a main circuit breaker(s).

Detail of instructions printed on transfer switch

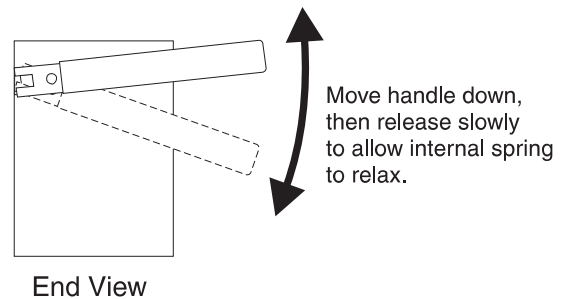
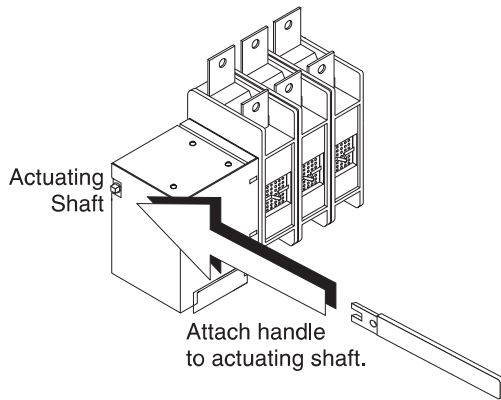
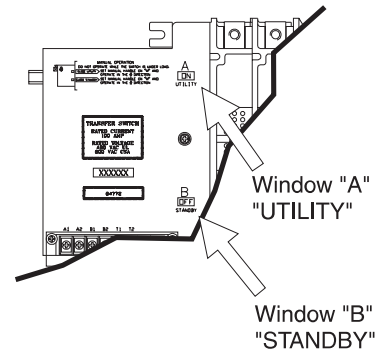
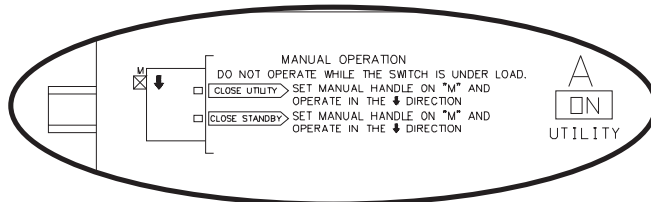

NOTE: Return handle to storage position in enclosure when finished with manual transfer

◆ 3.2.2 CLOSE TO STANDBY SOURCE SIDE

Before proceeding, ensure that the previous 3.2.1, “Step 2” Close to NORMAL Source Side is completed. See Figure 3.1. This will ensure that Window “B” on the switch reads “OFF”. With the handle attached to the actuating shaft, move the handle in the direction of the arrow on the switch cover until it stops - DO NOT FORCE. Release handle slowly to allow the spring in the switch box to relax. “OFF” now appears in Window “A” and “ON” appears in Window “B”.

◆ 3.2.3 RETURN TO NORMAL SOURCE SIDE

Manually actuate switch to return Window “A” to the “ON” position.

3.3 VOLTAGE CHECKS



Disconnect all loads from the transfer switch until all voltage checks and phase rotation checks have been completed to prevent possible injury to personnel and, or damage to equipment.



For safety, set the safety disconnect switch (inside transfer switch enclosure) to its manual position before proceeding with voltage checks.



Before proceeding, check the transfer switch data PLATE for switch rated voltage. Make sure the data plate voltage is compatible with NORMAL and STANDBY power source voltages.



Proceed with caution. Do not touch electrically hot terminals, wires, etc. During the voltage checks, the transfer switch is electrically energized.

Perform voltage checks as follows:

1. Inside the transfer switch enclosure, set the Safety Disconnect switch to MANUAL.
2. If generator is so equipped, set the Manual-Off-Auto switch to OFF.
3. On the switch enclosure door, set SYSTEM TEST switch to AUTOMATIC MODE position.
4. Check that the word “ON” is visible in Window “A”, the word “OFF” in Window “B”. See MANUAL OPERATION for location of “A” and “B” windows.

IMPORTANT: DO NOT PROCEED UNTIL STEPS 1, 2, 3, AND 4 HAVE BEEN COMPLETED.

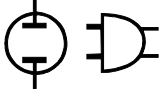

Before proceeding to voltage checks, manually connect the load to NORMAL power supply. window "A" must indicate ON, Window "B" must indicate OFF before proceeding.

- Turn ON the NORMAL (Utility) power supply to the transfer switch, with whatever means provided (such as the main line circuit breaker).



The transfer switch is now electrically hot. Proceed with caution.

- With UTILITY voltage available to the transfer switch, check that the SWITCH - POSITION UTILITY lamp on the enclosure door is ON. If the SWITCH - POSITION UTILITY lamp is OFF, turn off the utility power supply to the transfer switch by whatever means provided (such as the main line circuit breaker), then proceed back to Step 1 of "VOLTAGE CHECKS".
- Inside the transfer switch enclosure door, locate the Utility Voltage Sensor Circuit Board. The UTILITY ON light (LED) should be ON.
- With an accurate AC voltmeter, check the phase-to-phase (line-to-line) and phase-to-neutral (line-to-neutral) voltages present at transfer mechanism terminals N1, N2, N3 and neutral. SUPPLIED VOLTAGES MUST BE FULLY COMPATIBLE WITH TRANSFER SWITCH RATED VOLTAGE.



Ensure that the phase rotation of NORMAL (Utility) power lines and transfer switch load power lines are compatible.

- Refer to the standby generator instruction manual. Make sure the generator engine has been properly serviced and prepared for use, as outlined in that manual. Then start the generator engine manually. Let the engine stabilize and warm up for a few minutes.
- Turn ON the STANDBY (GENERATOR) power supply to the transfer switch by whatever means provided (such as the main line circuit breaker).
- With the generator running, check that the STANDBY - OPERATING light on the switch enclosure door is ON.
- With an accurate AC voltmeter, check phase-to-phase (line-to-line) and phase-to-neutral (line-to-neutral) voltages present at transfer mechanism terminals E1, E2 and E3. Also check AC frequency at those terminals. If frequency is incorrect, the engine governor may require adjustment. Generator AC output voltage and frequency must be compatible with transfer switch rated voltage and frequency.



Ensure that the phase rotation of STANDBY (GENERATOR) power lines and transfer switch NORMAL (UTILITY) and load power lines are compatible.

- If supplied voltage or frequency is incorrect, refer to standby generator Owner's Manual. If AC frequency is incorrect, adjust engine governed speed. If voltage is incorrect, adjust generator's voltage regulator or correct the problem.
- When supplied voltage and frequency is correct, shut down the engine manually.



Supplied voltages from both NORMAL (Utility) and STANDBY (Generator) power sources must be compatible with transfer switch rated voltage before proceeding.

- Connect the transfer switch load to the transfer switch when "voltage checks" section has been completed. Connect the load to the transfer switch by whatever means provided [such as circuit breaker(s)], then proceed with the "ELECTRICAL OPERATION" section.

3.4 ELECTRICAL OPERATION

Test transfer system electrical operation as follows:

- On the Utility Voltage Sensor circuit board, check that the UTILITY ON lamp (LED) is ON.
- On the enclosure door, check that the Switch Position-Utility lamp is ON.



The UTILITY ON lamp (on circuit board) and the SWITCH POSITION-UTILITY lamp (on enclosure door) must both be ON before proceeding to Step 3.

- Refer to the appropriate owner's manual. Be sure the standby generator is prepared for automatic operation.
- In the switch enclosure, set the Maintenance Disconnect switch to AUTOMATIC.
- Set the System Test switch to its NORMAL TEST MODE position. Generator startup and transfer to the STANDBY power source should occur. Refer to the SEQUENCE OF OPERATION, Section 3.13.

NOTE:

All systems are equipped with the Inphase Monitor Control board, and advisory lights on the circuit board will light up to indicate operation of the various solid state timers that control automatic operation. By observing these lights (LED’s), the operator can check the automatic operating sequences and times. See SENSOR AND TIMER ADJUSTMENTS, Section 3.16. For a detailed description of the automatic operating sequences, see SEQUENCE OF OPERATION, Section 3.13.

- When the test is complete, return the System Test Switch to its AUTOMATIC MODE position. Retransfer back to the UTILITY (normal) power source. The generator should shut down according to circuit board timers.

3.5 TRANSFER MECHANISM

- The transfer mechanism houses the main, current carrying contacts, along with other mechanical and electrical components required for operating the switch (Figure 3.2). Main contacts are actuated by a single solenoid, are electrically operated and mechanically held. Power for that coil’s operation is taken from the side to which the LOAD is being transferred. Thus, transfer to any power source cannot occur unless that power source is available to the switch.
- LOAD or “T” contacts, bolted to an insulated plastic pole piece are stationary. The NORMAL (utility) and STANDBY (emergency) contacts are moveable. The contacts are actuated by means of a closing coil and mechanical linkage. The pole assemblies which retain the stationary moveable main contacts are sandwiched together and retained by thru-bolts. Either 2, 3 or 4-pole assemblies may be used to form a 2, 3 or 4-pole mechanism.

Figure 3.2 — The Transfer Mechanism

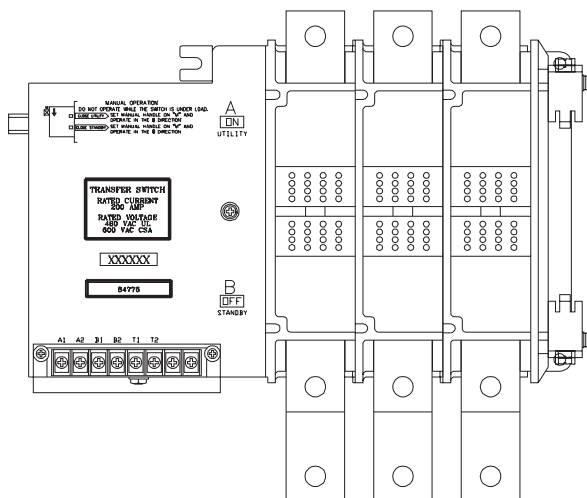

3.6 MAIN CONTACTS AT NORMAL (UTILITY)

The illustration shows the LOAD terminals connected to the NORMAL (utility) terminals. window “A” will display the word “ON”; Window “B” the word “OFF” (Figure 3.3).

Figure 3.3 — Main Contact at Normal (Utility)

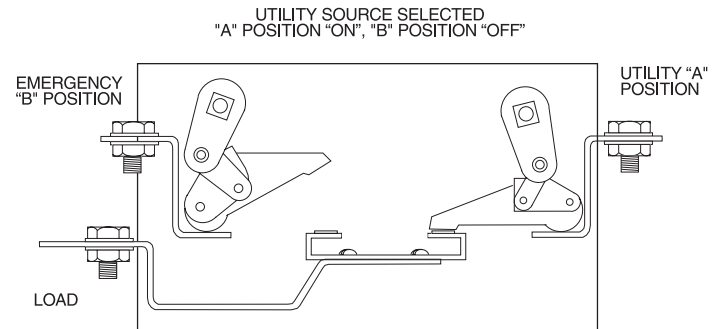

3.7 MAIN CONTACTS AT NEUTRAL

LOAD terminals are disconnected from both power supply terminals. The word “OFF” will be displayed in both Windows “A” and “B” (Figure 3.4).

Figure 3.4 — Main Contacts at Neutral

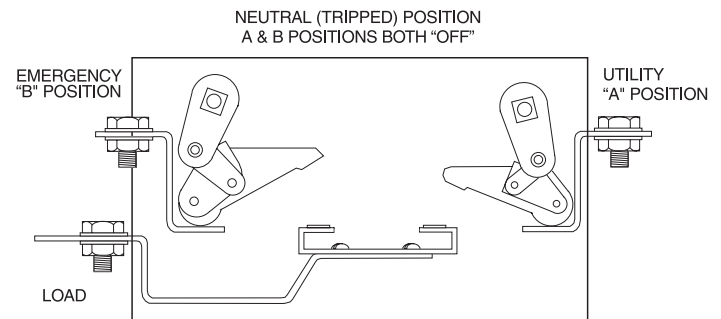

3.8 MAIN CONTACTS AT STANDBY (EMERGENCY)

LOAD terminals are connected to the standby (emergency) power supply. Window “B” will display the word “ON”; Window “A” the word “OFF” (Figure 3.5 on page 10).

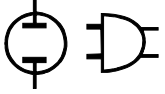

Figure 3.5 — Main Contacts at Standby (Emergency)

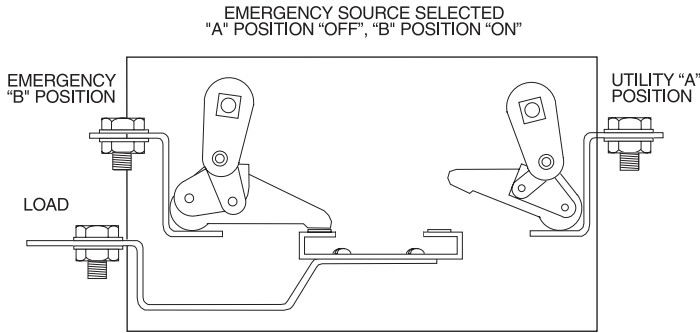
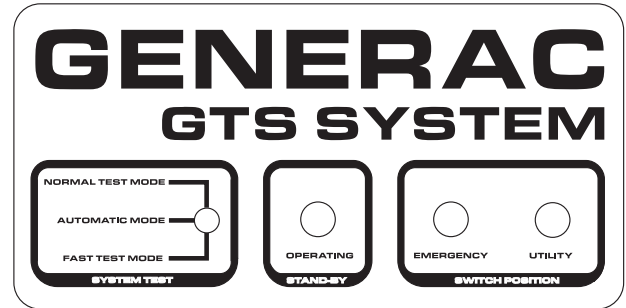

Figure 3.6 — System Test Switch, Standby Operating Light, and Switch Position Light



3.9 SWITCHES AND ADVISORY LAMPS

This section will familiarize the reader with switches and advisory lights on the transfer switch enclosure door, as well as with the Safety Disconnect Switch inside the switch enclosure.

Circuit board inside the switch door may also mount several switches. Operation of these switches will be covered in the section entitled SENSOR AND TIMER ADJUSTMENTS.

3.10 SYSTEM TEST SWITCH

This switch permits operator selection of AUTOMATIC, NORMAL TEST or FAST TEST mode as follows (Figure 3.6):

◆ 3.10.1 AUTOMATIC MODE

Use this switch position for all normal automatic operations. With AUTOMATIC MODE selected, any NORMAL source voltage that dropped below a pre-set value will result in the automatic sequence of events listed in the chart in Section 3.14.

◆ 3.10.2 NORMAL TEST MODE

Permits the operator to test automatic operations, just as though an actual drop in NORMAL source voltage had occurred. See the chart in Section 3.14. During the test, observe the lights (LED's) on the transfer switch circuit board to monitor automatic operating sequences.

◆ 3.10.3 FAST TEST MODE

Permits the operator to test system operation with all circuit board timers accelerated to less than five seconds. Switch is spring-loaded back to AUTOMATIC MODE, so continuously press the FAST TEST CONTROL. Following the generator startup, loads are transferred to the EMERGENCY (standby) power source as soon as EMERGENCY source voltage and frequency have reached the settings of STANDBY VOLTAGE and STANDBY FREQUENCY sensors on the SYSTEM CONTROL board.

3.11 STANDBY-OPERATING LIGHT

This light will go ON to tell the operator that the standby generator is running and that STANDBY (emergency) source power is available to the transfer switch.

3.12 SWITCH POSITION LIGHT

◆ 3.12.1 EMERGENCY

The light will go ON when main current-carrying contacts have actuated to their STANDBY (emergency) position and that power source is available to the transfer switch.

◆ 3.12.2 UTILITY

Light will go ON when main contacts have actuated to NORMAL (utility) position and that power supply is available to the transfer switch.

The switch is equipped with the Inphase Monitor Control circuit board. The sensors and timers are adjustable (see SENSOR AND TIMER ADJUSTMENTS).

3.13 SEQUENCE OF OPERATION

When acceptable NORMAL source voltage is available, you can observe the following:

- Utility voltage Sensor circuit board monitor's NORMAL source voltage and UTILITY ON lamp is ON.
- Switch Position - UTILITY lamp is ON.
- Transformer reduced LOAD (T) terminal voltage is delivered to the 7-day exerciser board to operate the 7-day exercise timer.

If you want, you can monitor automatic timers and sensors on the Inphase Monitor Control circuit board, by observing light emitting diodes (LED's) next to the sensor/timer adjustments.

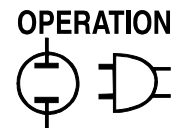

◆ 3.13.1 SEQUENCE 1 - VOLTAGE DROPOUT

- UTILITY source voltage drops below 75-95% of the Voltage Pickup Setting (factory set to about 80%). The UTILITY ON lamp goes OFF.
- Voltage Dropout sensor is factory set to about 80% of “pickup” voltage.
- Voltage dropout below this sensor’s setting triggers Sequence 2.

◆ 3.13.2 SEQUENCE 2 - LINE INTERRUPT DELAY

- UTILITY voltage dropout below setting of Voltage Dropout sensor turns on a Line Interrupt Delay Timer.
- Line Interrupt Delay may be set for 0.1 to 10 seconds; has been factory set to about 5 seconds.
- If voltage dropout lasts longer than Line Interrupt Delay setting, circuit board action closes the automatic start circuit (Wires 178 and 183). When that circuit closes, engine cranks and starts as controlled by a circuit board in the generator’s control panel.
- Once the standby generator starts, circuit board is turned ON (go to Sequence 3).

◆ 3.13.3 SEQUENCE 3 - ENGINE MINIMUM RUN AND WARMUP TIMERS

- This timer establishes the minimum length of time for the generator to run before you can shut it down. Timer prevents shutdown of a cold engine.
- Timer is adjustable from 5 to 30 minutes; factory setting is about 20 minutes.
- An engine warmup timer is also turned ON. This timer permits engine to stabilize and warm up before loads are transferred to STANDBY. Timer is adjustable from 5 seconds to 3 minutes; factory setting is about 1 minute.

◆ 3.13.4 SEQUENCE 4 - STANDBY VOLTAGE AND FREQUENCY SENSORS

- If generator AC output voltage and frequency is above the setting of these sensors, loads transfer to the STANDBY power source.
- Adjust Standby Voltage Sensor between 80% and 90% or nominal supply frequency; factory setting is about 90%.
- Adjust Standby Frequency Sensor between 80% and 90% or nominal supply frequency; factory setting is about 90%.

NOTE:

You can bypass the engine warmup timers by setting the Engine Warmup Timer Bypass switch to ON. Loads are transferred to STANDBY as soon as generator AC voltage and frequency have reached the settings of the Voltage and Frequency sensors without having to wait for the engine to warm up.

◆ 3.13.5 SEQUENCE 5 - VOLTAGE PICKUP

- If the UTILITY source voltage is restored above the setting of the Voltage Pickup sensor, Sequence 5 begins.
- Adjust Voltage Pickup between 85% to 95% of the normal supply voltage from the UTILITY source; factory setting is about 90%.

◆ 3.13.6 SEQUENCE 6 - RETURN TO UTILITY TIMER

- This timer prevents re-transfer that a Utility Source voltage surge or transient might cause.
- Adjust timer between 1 to 30 minutes; factory setting is about 5 minutes.
- If UTILITY voltage remains above the setting of the Voltage Pickup Sensor for the time interval of the Return to Utility Timer setting, loads are re-transferred back to the UTILITY source.

◆ 3.13.7 SEQUENCE 7 - ENGINE COOL DOWN TIMER

- After the switch re-transfers loads back to UTILITY, this timer starts. When the interval has “timed out”, the automatic start circuit (Wires 178/183) is opened, and the engine shuts down.
- Timer permits engine to run at no-load for a fixed time, so the engine internal temperature can stabilize before shutting down.
- Set the timer for 1-30 minutes; factory setting is about 10 minutes.

NOTE:

Actual time between re-transfer back to UTILITY and engine shutdown is whichever is longer of the Engine Cool Down timer setting or any time remaining on Engine Minimum run timer.

After the switch automatically re-transferred loads back to the UTILITY power source and generator has shut down, the system is “armed” for Sequence 1 again.

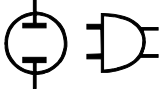

3.14 SEQUENCE OF OPERATION SETTINGS

Units with Inphase Monitor Control Circuit Board

SEQUENCE	ACTION	TIMER/SENSOR	ADJUST RANGE	FACTORY SETTING
—*	UTILITY volts available - no action	Voltage Dropout Sensor	75 - 95%	80%
A*	UTILITY voltage drops out	Voltage Dropout Sensor	75 - 95%	80%
B	Line Interrupt Delay Timer Starts	Line Interrupt Delay Timer	0.1 - 10 seconds	5 seconds
C	Line Interrupt Delay Timer Stops	Line Interrupt Delay Timer	.01 - 10 seconds	5 seconds
—	Engine cranks and starts			
D	Engine Minimum Run Timer starts	Engine Minimum Run Timer	5 to 30 minutes	20 minutes
E**	Engine Warmup Timer Starts	Engine Warmup Timer	5 sec. - 3 min.	1 minute
F	STANDBY ON lamp ON			
G**	Engine Warmup Timer stops	Engine Warmup Timer	5 sec. - 3 min.	1 minute
H	Is STANDBY voltage good?	Standby Voltage Sensor	75 - 95%	90%
J	Is STANDBY frequency good?	Standby Frequency Sensor	80 - 90%	90%
K	Time Delay at NEUTRAL	Time Delay Neutral Timer	0.1 - 10 seconds	5 seconds
L	Inphase Transfer	Inphase Transfer Select	None	
—	Transfer to STANDBY			
M	TRANSFER TO STANDBY lamp ON			
—	STANDBY source powers LOAD			
N	UTILITY voltage restored	Voltage Pickup Sensor	85 - 95%	90%
O	Return to UTILITY Timer ON	Return to Utility Timer	1 - 30 minutes	5 minutes
P	Timed Delay at NEUTRAL	Time Delay Neutral Timer	0.1 - 10 seconds	5 seconds
R	Inphase Transfer	Inphase Transfer Select	none	0.1 - 30 seconds
S	Signal Before Transfer LED lights	Signal Before Transfer Timer	1 - 30 seconds	10 seconds
—	Re-transfer to UTILITY source			
T***	Engine Cooldown Timer starts	Engine Cooldown Timer	1 - 30 minutes	10 minutes
U***	Engine Cooldown Timer stops	Engine Cooldown Timer	1 - 30 minutes	10 minutes
—	Engine shuts down			
—	UTILITY volts available - no action			

* 75 - 95% of the Voltage Pickup Sensor setting

** Engine Warmup Timer can be bypassed. See SENSOR AND TIMER ADJUSTMENTS

*** Following re-transfer to UTILITY source, engine shutdown will not occur until both Engine Minimum run and Engine Cooldown timers have timed out.

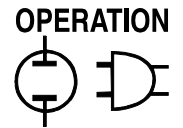

3.15 TRANSFER SWITCH OPTIONS

The transfer switch may be equipped with one or more of the following options:

- 3-wire Start System
- Instrument Package
- Deluxe Exerciser Circuit Board
- NEMA 3R, 4, 4X, or 12 Enclosure

◆ 3.15.1 3-WIRE START SYSTEM

The standard generator start circuit on Generac transfer switches is a “2-wire” type. If the standby generator being installed has a “3-wire” start/stop system, you may need to use a transfer switch with a 3-wire system.

The optional 3-wire start system includes a 6-point terminal strip, a control relay, terminal strip decal and required wiring (Figure 3.7). These components are shown in the REPAIR PARTS section. Terminal strip connections are shown below:

- Terminal 178 - + 12 volts DC supply. On Generac generators, connect to generator Terminal #15.
- Terminal 10 - Common ground. Connect to negative (-) side of the DC supply circuit (to Terminal #10 on Generac generators).
- Terminal 213 - Acts as the COMMON terminal for the normally-open (N.O.) START and the normally-closed (N.C.) STOP relay contacts.
- Terminal 136 - N.O. START terminal. On Generac generators, connect to generator Terminal #136.
- Terminal 18 - N.C. STOP terminal. On Generac generators, connect to generator Terminal #18.

Figure 3.7 — 3-Wire Start System

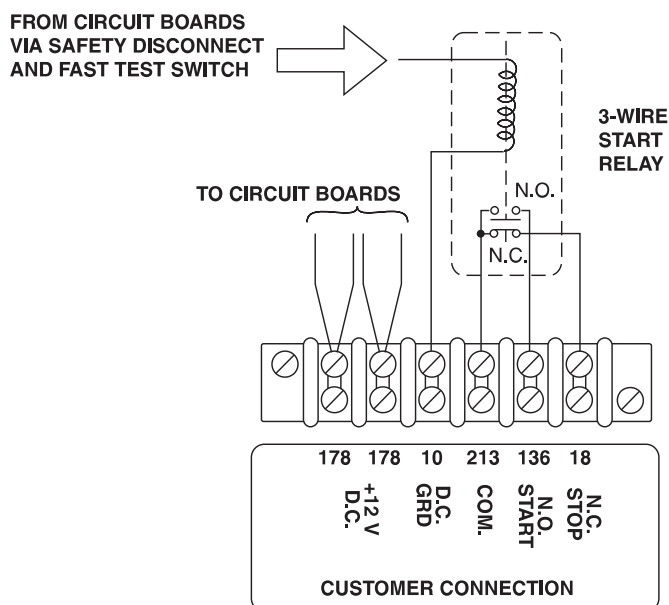

◆ 3.15.2 INSTRUMENT PACKAGE

The optional instrument package includes (a) an AC voltmeter, (b) an AC ammeter, (c) an AC frequency meter, (d) an hourmeter, and (e) a phase selector switch. Several current transformers are required to operate the instrument package, i.e., two for single phase systems, three for 3-phase systems. Use the phase selector switch to select the 1-phase voltage and current being read as follows:

For 3-phase systems use the switch as follows:

SWITCH OPERATION	CURRENT READING	VOLTAGE READING
1	Line 1	Line 1 to Neutral
2	Line 2	Line 2 to Neutral
3	No reading	Line 1 to Line 2
OFF	No reading	No reading

SWITCH OPERATION	CURRENT READING	VOLTAGE READING
1	Phase A	Phase A to Phase B
2	Phase B	Phase B to Phase C
3	Phase C	Phase C to Phase A
OFF	No reading	No reading

Figure 3.8 — Instrument Package

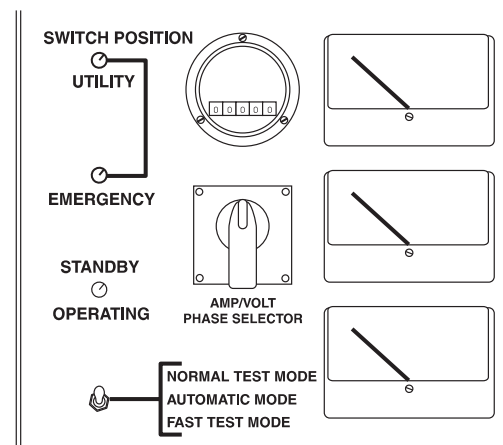

◆ 3.15.3 OPTIONAL DELUXE EXERCISER CIRCUIT BOARD

See OPTIONAL DELUXE EXERCISER CIRCUIT BOARD SETTINGS, Section 3.21.

◆ 3.15.4 NEMA 12 ENCLOSURE

National Electrical Manufacturer’s Association (NEMA) 12 enclosure. This type of enclosure is intended for use indoors to provide a degree of protection against dust, falling dirt, and dripping, non-corrosive liquids. Ask your Dealer/Distributor or consult the factory for details.

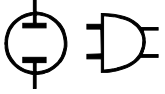

◆ 3.15.5 NEMA 3R ENCLOSURE

National Electrical manufacturer’s Association (NEMA) 3R enclosure. This type of enclosure is intended for use outdoors to protect enclosed parts from windblown dust and water. The enclosure is sealed for dust, rain or sleet and is ice resistant. Ask your Dealer/Distributor or consult the factory for details.

◆ 3.15.6 NEMA 4 ENCLOSURE

National Electrical Manufacturer’s Association (NEMA) 4 enclosure. This type of enclosure is intended for use indoors or outdoors to provide a degree of protection against windblown dust and rain, splashing water, and hose-directed water: undamaged by the formation of ice on the enclosure. Ask your Dealer/Distributor or consult the factory for details.

◆ 3.15.7 NEMA 4X ENCLOSURE

National Electrical Manufacturer’s Association (NEMA) 4X enclosure. This type of enclosure is intended for use indoors and outdoors to provide a degree of protection against corrosion, windblown dust and rain, splashing water, and hose-directed water: undamaged by the formation of ice on the enclosure. Ask your Dealer/Distributor or consult the factory for details.

◆ 3.15.8 ADDITIONAL OPTIONS

For information on additional options not covered in this manual, ask you Dealer/Distributor or consult the factory.

3.16 SENSOR AND TIMER ADJUSTMENTS – SENSING CIRCUIT BOARD

◆ 3.16.1 VOLTAGE DROPOUT SENSOR

This sensor (Figure 3.9) establishes the NORMAL power source voltage which generator startup and transfer to STANDBY (Emergency) power source occurs. Adjust the sensor to any voltage between 75-95% of the nominal voltage Pickup Sensor setting, by turning the adjusting knob to the desired setting (in percent). Sensor is factory set to about 80% of the Voltage Pickup Sensor setting.

◆ 3.16.2 VOLTAGE PICKUP SENSOR

Establishes the NORMAL power source voltage at which re-transfer back to that power source occurs. Turn knob to adjust setting to 85-95% of the nominal NORMAL source supply voltage. Sensor has been factory set to about 90% of nominal rated NORMAL source voltage.

◆ 3.16.3 LINE INTERRUPT DELAY TIMER

Established a definite time interval between NORMAL source voltage dropout below the setting of the Voltage Dropout Sensor and generator startup. This time interval is necessary to prevent false generator starts that voltage transients might otherwise cause. Adjust timer from 0.1 to 10 seconds; is factory set to about five seconds.

Figure 3.9 — Sensing Circuit Board Panel

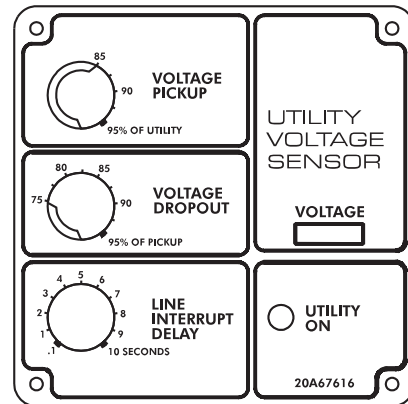

3.17 ADJUSTMENTS ON INPHASE MONITOR CONTROL CIRCUIT BOARD

The Inphase Monitor Control board is operational only when the generator set is running. Transfer will occur when UTILITY and GENERATOR voltage and phase are comparatively equal with a maximum difference of 20° between the power sources. To assure precision matching control, minimum voltage and frequency ranges are specified by the operator. In addition, each inphase control is programmed with the use of an onboard DIP switch to match the actuation time of the corresponding switch. Inphase transfer is used only between two live power sources and NOT during a UTILITY source failure. The Inphase Monitor Control board (Figure 3.10) is designed to transfer loads under the following conditions:

- When generator set frequency is between 58-62 Hz (48-52 Hz for 50 Hz systems).
- When generator set and utility power source frequencies are within 2 Hz.
- When the generator set and utility source voltage are within 85-100 percent of normal voltage.
- When both power sources are able to come into phase within 10 seconds.
- When less than 10 seconds has elapsed since the engine warmup timer has indicated “go ahead.”

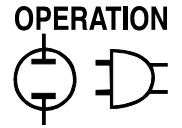

If any one of the preceding conditions are not met within 30 seconds, the system will automatically revert to Time delay Neutral (if selected). If Time Delay Neutral is not selected, the switch will transfer immediately after failing to do an inphase transfer within the 30 second window.

◆ **3.17.1 ENGINE WARMUP TIMER**

Permits the engine to warm up before transferring LOAD from NORMAL to STANDBY power. Reset timer to any time interval between 5 seconds and 3 minutes; factory set to about 1 minute.

◆ **3.17.2 ENGINE MINIMUM RUN TIMER**

Establishes the minimum length of time the generator must run before it can be shut down automatically. Timer prevents a cold engine from being shut down. It is factory set to about 20 minutes, but you can reset the interval between 5 and 30 minutes.

◆ **3.17.3 RETURN TO UTILITY TIMER**

Establishes time interval between restoration of NORMAL source voltage above the setting of the Voltage Pickup Sensor and re-transfer back to that source. This time interval is necessary, to prevent re-transfer that otherwise might occur as a result of transient voltages. Timer may be reset to any interval between 1 and 30 minutes; factory set to about 5 minutes.

◆ **3.17.4 ENGINE COOL DOWN TIMER**

Provides a time delay between automatic re-transfer back to the NORMAL source and engine shutdown. This permits internal engine-generator temperatures to stabilize at “no-load” prior to shutdown. Set timer between 1 and 30 minutes; factory set to about 10 minutes.

NOTE:

The actual time interval between re-transfer back to NORMAL and generator shutdown, is the time remaining on Engine Minimum Run timer or time setting of the Engine Cool Down Timer, whichever is longer.

◆ **3.17.5 STANDBY VOLTAGE SENSOR**

After engine starts automatically, the system does not transfer LOAD to STANDBY power source until generator AC output voltage has reached the setting of this sensor. Factory set to about 90% of the nominal rated voltage, but you can reset between 75% and 95% of the unit’s rated voltage.

◆ **3.17.6 STANDBY FREQUENCY SENSOR**

This adjustment allows the installer or operator to select the minimum required frequency of the standby power source. It is adjustable between 80-90%. Factory set to 90%.

Figure 3.10 — Inphase Monitor Control Panel

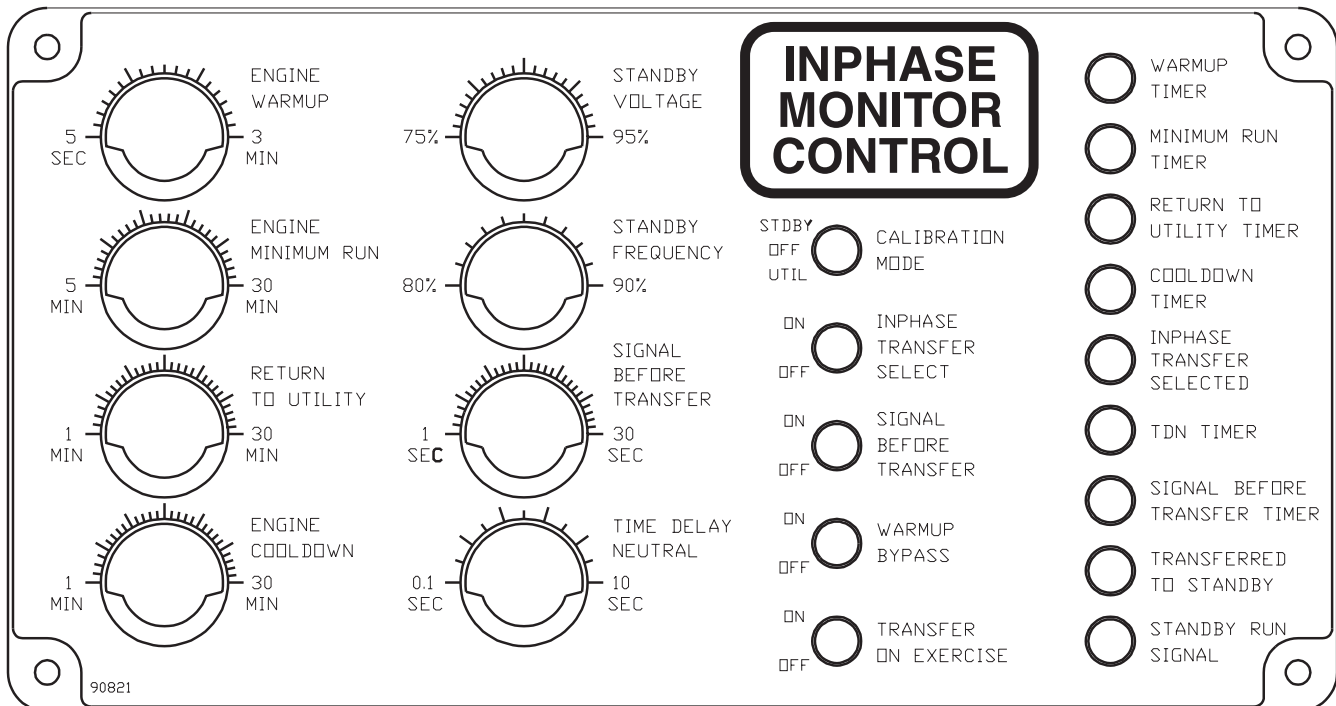

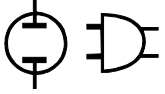

◆ 3.17.7 SIGNAL BEFORE TRANSFER TIMER

If you select this function, this timer will control the amount of time signal remains active. Timer is adjustable from 1 to 30 seconds; factory set to about 10 seconds.

NOTE:

The “Signal Before Transfer” feature provides a time delay that allows elevators to continue operating before transfer to another power supply occurs.

◆ 3.17.8 TIME DELAY NEUTRAL

This timer holds the transfer mechanism’s main contacts in the “Neutral” position for the time you have selected. “Neutral” is the main contacts position where the LOAD is disconnected from both UTILITY and STANDBY power supplies. Timer is adjustable from 0.1 and 10 seconds; factory set to about 5 seconds.

◆ 3.17.9 CALIBRATION MODE SWITCH

This switch has three positions, identified as “STDBY”, “OFF” and “UTIL”. The switch allows the installer or operator to calibrate the circuit board to the existing generator set output voltage and to the existing UTILITY power source voltage. The board must be calibrated to both power source voltages in order to initiate transfer and re-transfer at the correct voltages. To calibrate the circuit board to the correct voltage, see “Calibrating the Circuit Board.”

◆ 3.17.10 INPHASE TRANSFER SELECT SWITCH

This switch allows the operator or installer to select either “Inphase Transfer” or “Time Delay Neutral” operation. The switch may be positioned as follows:

- Switch at ON: Inphase transfer operation is selected.
- Switch at OFF: Time Delay Neutral is activated if selected.

◆ 3.17.11 SIGNAL BEFORE TRANSFER SWITCH

This switch allows the operator or installer to select the “Signal Before Transfer” feature or to turn OFF the feature. To activate the feature, set the switch to ON. To turn off the feature, set the switch to OFF.

◆ 3.17.12 ENGINE WARMUP TIMER BYPASS SWITCH

To bypass Engine Warmup Timer and transfer as soon as generator voltage and frequency have reached the setting of the Standby Voltage and Frequency Sensors, set switch to ON. To place engine warmup Timer back into the automatic operating system, set the switch to OFF.

◆ 3.17.13 TRANSFER ON EXERCISE SWITCH

For transferring LOAD to the STANDBY source during the 7-day exercise cycle, set switch to ON. For no transfer during the exercise, set switch to OFF.

◆ 3.17.14 ADVISORY LAMPS

The advisory lamps on the Inphase Control board consist of 9 LED’s (light emitting diodes) and include the following:

- The four red timer lamps will turn ON when their respective timers are activated.
- The “Inphase Transfer Selected” lamp goes ON when Inphase Transfer Select switch is set to ON, indicating the system will operate in its “Inphase” mode (and NOT in Time Delay Neutral mode).
- The Time Delay Neutral (TDN) Timer lamp will turn ON when the TDN timer is running.
- The Signal Before Transfer Timer lamp will turn ON for the duration of the Signal Before Transfer Timer, when it is turned ON.
- Transfer to Standby Lamp goes ON when LOAD has been transferred to STANDBY power source.
- Standby run Signal will go ON when the generator is running and the Inphase Monitor Control circuit board is operational and controlling the generator.

3.18 CALIBRATING THE INPHASE MONITOR CONTROL CIRCUIT BOARD

The Inphase Monitor circuit board must be calibrated to existing STANDBY and UTILITY source voltages if the system is to operate properly. To calibrate the circuit board, two adjustment potentiometers (R102 and R107) are provided in the lower left corner of the circuit board. The board must be calibrated as follows:

1. Check that UTILITY supply voltage is available to the system.
2. Start the generator, let it stabilize and warm up.
3. Set the Calibration Mode Switch to “STDBY” and observe the four top LED’s on the circuit board (Warmup Timer, Minimum Run Timer, Return to Utility Timer and Cool down Timer). These are the RED lamps.
 - If the two upper LED’s are illuminated, calibration is set too low.
 - If the two bottom LED’s are illuminated, calibration is set too high.
4. On the circuit board, adjust potentiometer R102 until only the two center LED’s are illuminated (Minimum Run and Return to Utility timers).
5. Now, set the Calibration Mode switch to “UTIL” and observe the four upper LED’s on the circuit board.

Figure 3.11 — Inphase Monitor Control Circuit Board

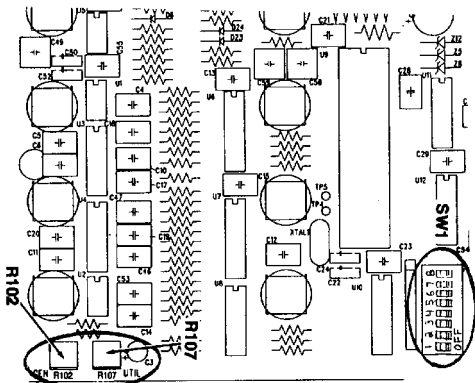

3.19 CIRCUIT BOARD SWITCH SW1

On the Inphase Monitor Control Board, a switch assembly consisting of a bank of eight miniature switches is identified as “SW1” is usually set up at the factory and should require no additional configuring (Figure 3.12).

NOTE:

On boards not installed at the factory, SW1 must be set by the installer. SW1 must be set to match the type of transfer switch in which the board is installed.

The individual switches on SW1 are numbered from “1” (bottom) through “8” (top), as shown in figures 3.11 and 3.12. To make the circuit board compatible to the specific transfer switch assembly, set the switches as indicated in the chart below. Improper settings may cause transfer outside the 20-degree specification.

Figure 3.12 — Circuit Board Switch SW1

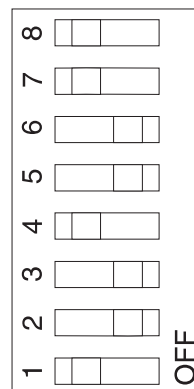

- Adjust potentiometer R107 until only two center LED's are illuminated (Minimum Run and Return to Utility).
- Set the Calibration Mode Switch to “OFF”. The Inphase Monitor Control board is calibrated.

NOTE:

With the Calibration Mode Switch set to “STDBY” or “UTIL”, the four top LED's should turn ON in sequence. That is, the lights should sweep on and off, from one light to the next. Calibration is obtained when the two center lamps of the four (Minimum Run and Return to Utility) are illuminated. This establishes 100% rated voltage.

NOTE:

The Inphase Monitor Control circuit board should be calibrated when the transfer switch has been installed as part of an operating system. Also, replacement circuit boards must be calibrated.

DIP Switch Settings - W-Type Transfer Switches

TRANSFER SWITCH	SWITCH RATED 100/200; 110/220; 115/200; 120/208; 220/380 VOLTS								SWITCH RATED 120/240; 231/400; 240/416 VOLTS								SWITCH RATED 277.480; 346/600 VOLTS							
	1	2	3	4	5	6	7	8	1	2	3	4	5	6	7	8	1	2	3	4	5	6	7	8
100 amps, 2-pole (64772)	*	on	off	off	on	off	off	on	*	on	off	off	on	off	off	on	*	on	off	off	on	off	on	off
100 amps, 3-pole (64773)	*	on	off	off	on	off	off	off	*	on	off	off	on	off	off	on	*	on	off	off	on	off	on	off
100 amps, 4-pole (64774)	*	on	off	off	on	on	off	off	*	on	off	off	on	on	on	off	*	on	off	off	on	on	on	off
150 amps, 2 pole (A8185)	*	on	off	off	on	on	off	on	*	on	off	on	off	off	off	on	*	on	off	off	on	on	on	off
150 amps, 3-pole (A8186)	*	on	off	off	on	on	on	off	*	on	off	on	off	off	off	on	*	on	off	on	off	off	off	off
150 amps, 4-pole (A8187)	*	on	off	on	off	on	on	off	*	on	off	on	on	off	off	on	*	on	off	on	off	on	on	off
200 amps, 2-pole (64775)	*	on	off	off	on	on	off	on	*	on	off	on	off	off	off	on	*	on	off	off	on	on	on	off
200 amps, 3-pole (64776)	*	on	off	off	on	on	on	off	*	on	off	on	off	off	off	on	*	on	off	on	off	off	off	off
200 amps, 4-pole (64777)	*	on	off	on	off	on	on	off	*	on	off	on	on	off	off	on	*	on	off	on	off	on	on	off
300 amps, 2-pole (64778)	*	off	on	off	on	on	on	off	*	off	on	on	off	off	off	on	*	off	on	off	on	on	on	on
300 amps, 3-pole (64779)	*	off	on	on	off	off	off	off	*	off	on	on	off	off	off	on	*	off	on	on	off	off	off	on
300 amps, 4-pole (64780)	*	off	on	on	off	off	off	on	*	off	on	on	off	on	on	on	*	off	on	on	off	on	off	off
400 amps, 2-pole (64781)	*	off	on	off	on	on	on	off	*	off	on	on	off	off	on	on	*	off	on	off	on	on	on	on
400 amps, 3-pole (64782)	*	off	on	on	off	off	off	off	*	off	on	on	off	off	on	on	*	off	on	on	off	off	off	on
400 amps, 4-pole (64783)	*	off	on	on	off	off	off	on	*	off	on	on	off	on	on	on	*	off	on	on	off	on	off	off

* Set Switch 1 to OFF for 60 Hz systems; set Switch to ON for 50 Hz systems

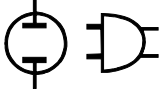

3.20 ADJUSTMENTS ON 7-DAY EXERCISER CIRCUIT BOARD

◆ 3.20.1 SET EXERCISE DAY AND TIME OF DAY

On the day and at the time of day you want the system to start and exercise, press the GENERATOR EXERCISE switch and hold it there for about 15 seconds. The generator will start and exercise 7 days later at the selected time of day.

Figure 3.13 — 7-Day Exerciser

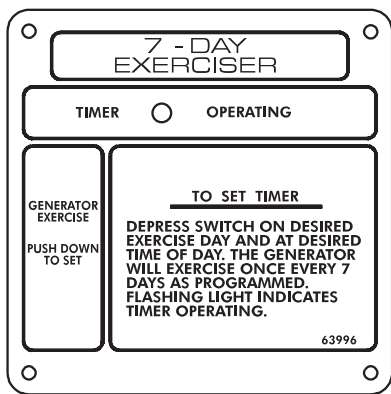

3.21 OPTIONAL DELUXE EXERCISE CIRCUIT BOARD SETTINGS

Always adjust the board in the exact order given (Figure 3.14).

1. Set Actual Day of Week: Locate the switch above which appears the words “ADVANCE DAY”. Press this Advance Day switch while watching the lighted DAY OF WEEK indicator. That indicator advances one day each time you press the switch. You can stop when the actual current day of the week is displayed.
2. Set Actual Time of Day: Hold FAST SET switch down while watching the lighted chronograph at left side of circuit board. When close to actual current time of day, release the FAST SET switch. Then, use the SLOW SET switch to complete adjustment of actual time of day.
3. Select Dat (or Days) of Exercise: A bank of eight miniature rocker switches is provided at right side of circuit board. Switches 1 through 7 correspond to days of the week (Sunday through Saturday respectively). Switch 8 is not used. To select a day of the week for system exercise, move the correct numbered switch to its ON position. A lighted band appears next to that day. In this manner, the system can be set to exercise one, two or more days each week.

4. Select Exercise Time of Day: Push down on switch below the words DISPLAY EXERCISE TIME. While holding that switch down, press FAST SET and SLOW SET switches until the time you want is displayed. A red dot next to the letters “PM” indicates p.m. times.

Figure 3.14 — Deluxe 7-Day Exerciser

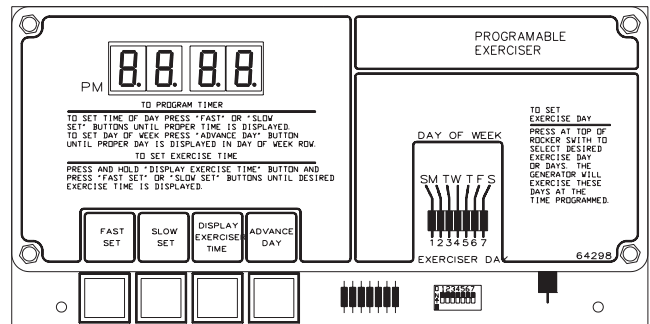

3.22 CALIBRATE UTILITY VOLTAGE SENSING CIRCUIT BOARD

The utility sensing interface reduces utility source voltage at a fixed ratio. Thus, if utility voltage varies from the nominal, sensing voltage to the circuit board also varies. For that reason, you may need to calibrate the circuit board to match the system.



The installed transfer switch must be rated at a voltage and phase that is compatible with the utility and standby power supplies. DO NOT attempt to calibrate any utility voltage sensor board on any non-compatible unit trying to make the unit compatible.

Once the circuit board has been properly calibrated, the voltage that was present during calibration establishes 100 percent utility voltage for “pickup” and “dropout” settings. Utility source voltage must be available to the transfer switch during calibration.

NOTE:

You must also use this procedure to calibrate a replacement circuit board. Follow these instructions:

1. In the transfer switch enclosure, set the Safety Disconnect Switch to “Manual”.
2. On the Utility Voltage Sensor circuit board, locate test points “TP3” and “TP4” and install a jumper lead.
3. Locate the small potentiometer “R10”. Turn the potentiometer fully counterclockwise.

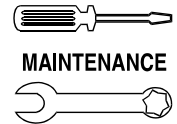

4. Now, turn the “R10” potentiometer SLOWLY clockwise until the “Utility On” light emitting diode (LED) just turns ON.
5. Remove the jumper wire from “TP3” and “TP4”.
6. Reset the Maintenance Disconnect switch to AUTOMATIC.

RESULTS:

- If the “Utility On” LED does NOT go on as described above, replace the utility voltage sensor board. Calibrate the new board and perform a “Normal Test” of the system.
- If the “Utility On” LED goes ON, discontinue the test.

Figure 3.15 — Utility voltage Sensing Circuit Board

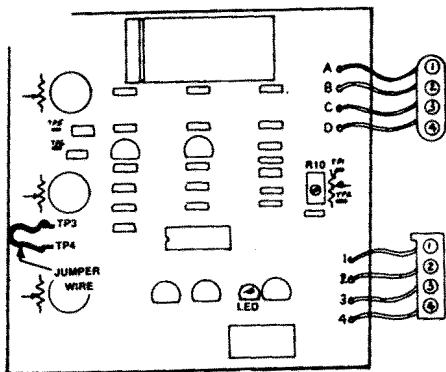

4.1 OPERATE TRANSFER SWITCH

Operate the transfer switch at least once each month. This can be done by performing a NORMAL TEST of the system. Because the System Test switch only simulates failure of the UTILITY power source, service will be interrupted only during the actual transfer of the load.

4.2 CLEAN AND INSPECT TRANSFER SWITCH

Protect the transfer switch against construction grit, metal chips, excessive moisture and other harmful dirt at all times. At least once each year turn OFF all power supplies to the switch, then brush and vacuum away dust and dirt that has accumulated inside the enclosure. After cleaning, inspect the transfer switch carefully. Look for evidence of arcing, burning, hot spots, charring and other damage. If any of these are found, have the switch assembly checked by an authorized service technician.

4.3 7-DAY EXERCISER

On each transfer action, the LOAD will be disconnected from both power sources for a brief interval. During such brief intervals, the exercise timer is powered by the 9 volt battery. However, the timer will not advance during the transfer. For that reason, it may be necessary to reset the exercise timer periodically.

4.4 LUBRICATION

Operating parts inside the transfer mechanism have been properly lubricated at the time of assembly. Under normal conditions no additional lubrication should be required. The service technician should lubricate all recommended points whenever major transfer mechanism components are replaced.



Use only specified greases to lubricate contactor parts. DO NOT USE ANY SUBSTITUTES.

Use the following lubricants for the:

1. Main Contacts (Between movable contact and bus-bars).
 - Dow Corning (Molykote) BR2 Plus; (Mfg. by Dow Corning Co., USA)
 - Liqui-Moly (Mfg. by DAI TO Co., Ltd., Japan)
2. Operating Mechanism (Used on the actuator and other parts of the contactors. Excluding the movable contacts).
 - Mobilgrease 28 (Mfg. by Mobil Oil Co.)
 - Mobiltemp SHC 32 (Mfg. by Mobil Oil Co.)
 - Polo Moly Complex Grease #NLG12 (Mfg. by Polo Lubricants, USA)
 - Rheolube 363 (Mfg. by Nye Lubricants Inc., USA)

4.5 MAIN CURRENT CARRYING CONTACTS

At least once annually, have an Authorized Service Technician check the main current carrying contacts in the transfer mechanism. He will repair or replace major components that have been found defective.

4.6 NINE-VOLT BATTERY

The transfer switch is equipped with an adjustable Inphase Monitor Control circuit board. The battery connects to a separate 7-day exerciser circuit board. Battery power for Exercise Timer operation is only needed during the short time interval when the transfer mechanism main contacts are at NEUTRAL position (LOAD disconnected from both power sources). It is recommended that the 9 volt battery be replaced once each year.



Section 5 – Mounting Dimensions

Generac GTS "W" Type Transfer Switch

100 Amp NEMA 1 Units

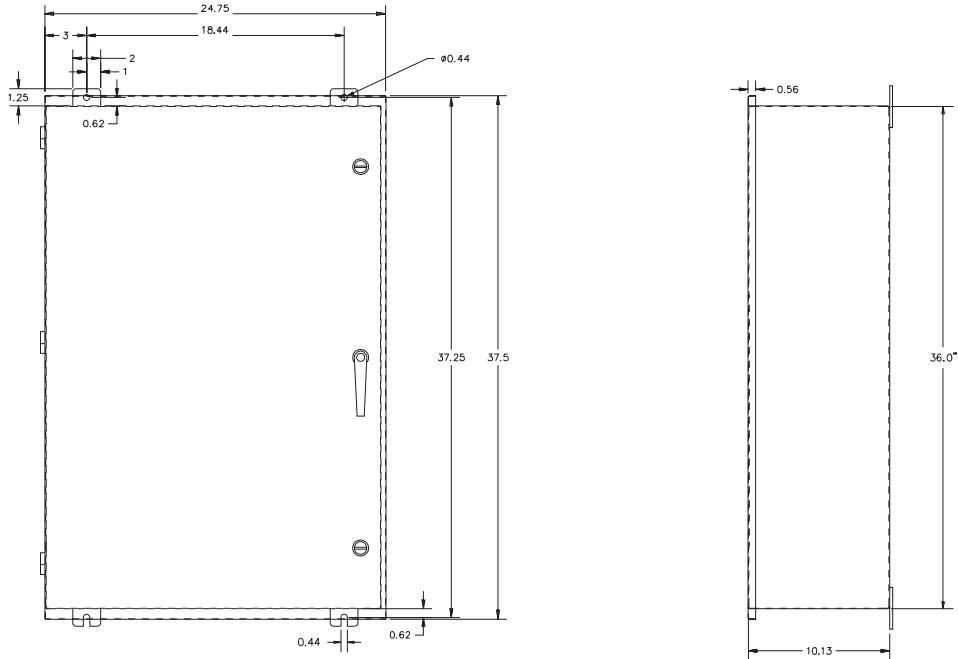

150-400 Amp NEMA 1 Units

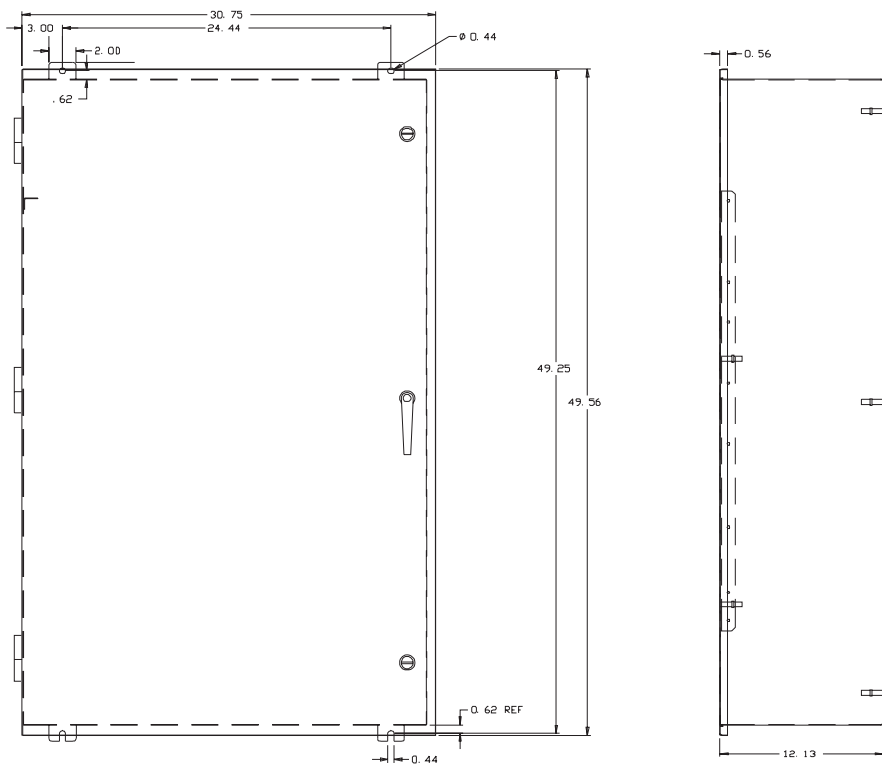

Section 5 – Mounting Dimensions
Generac GTS "W" Type Transfer Switch

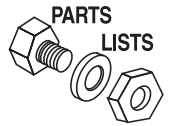

100 Amp NEMA 12, 3R, 4, and 4X Units (Typical)

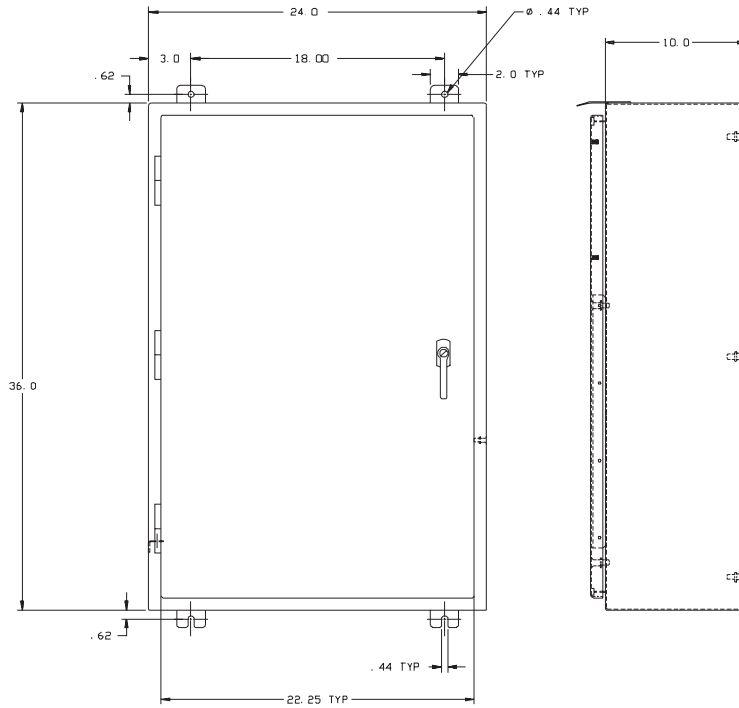

150-400 Amp NEMA 12, 3R, 4 and 4X Units (Typical)

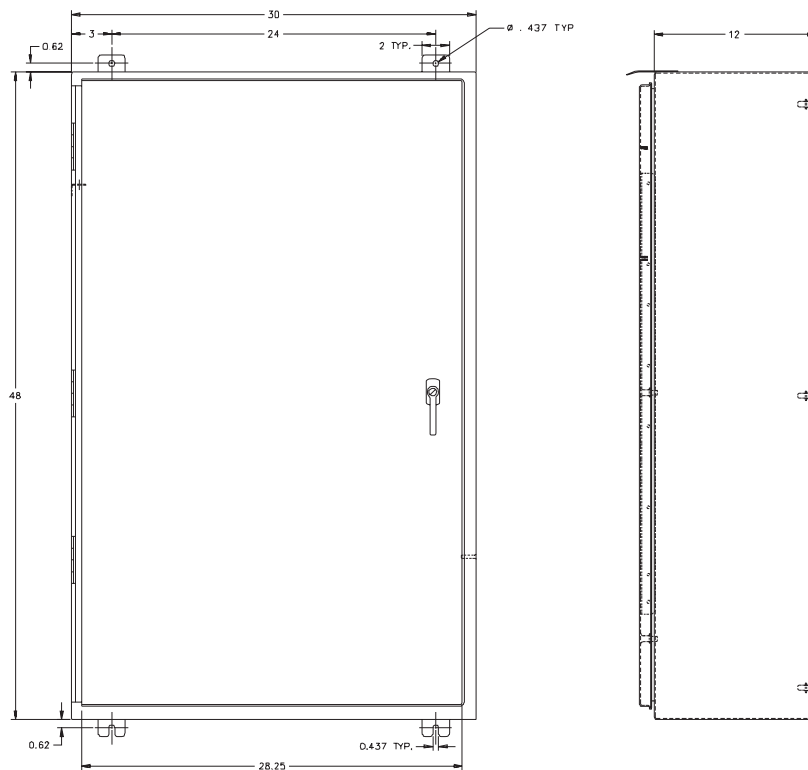

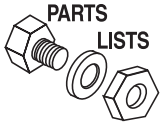

Section 5 – Mounting Dimensions
Generac GTS “W” Type Transfer Switch

100 Amp NEMA 12 Units With Instrument Package

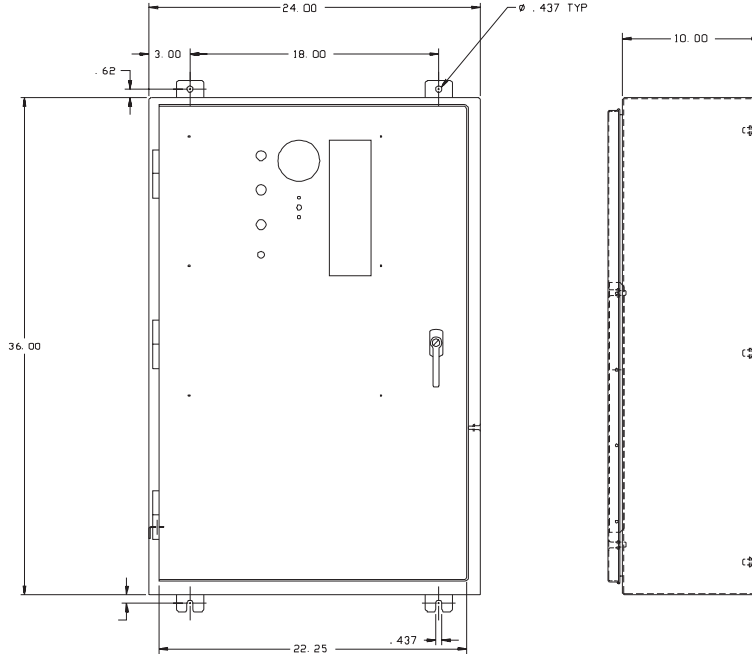

150-400 Amp NEMA 12 Units With Instrument Package

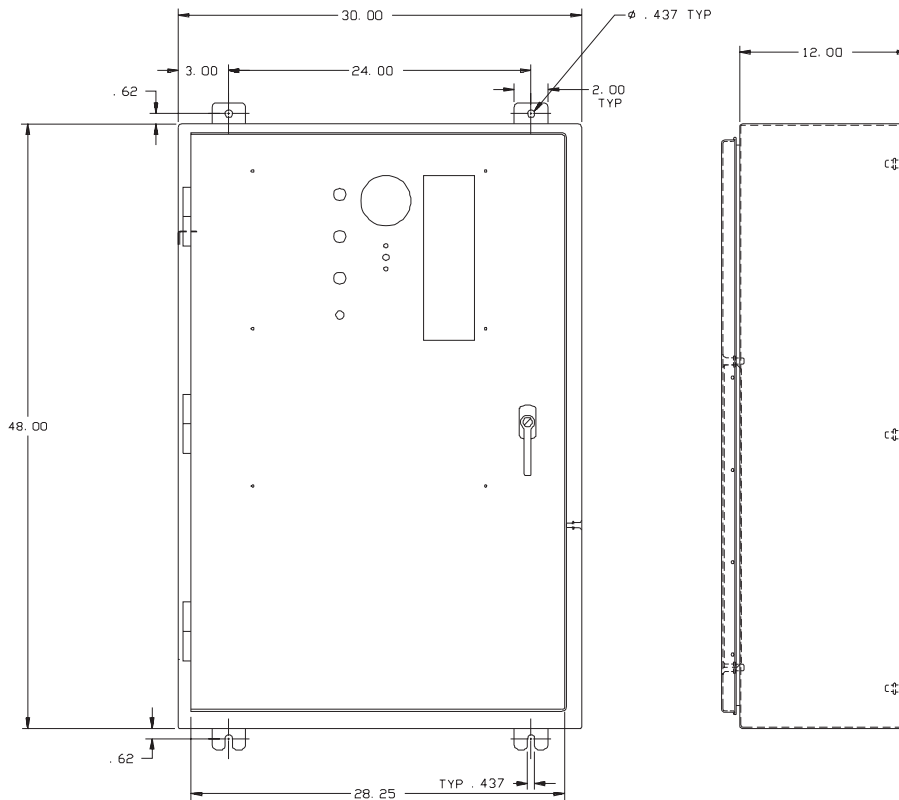

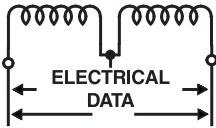

Section 6 – Wiring Diagrams & Electrical Schematics

Schematic - 208/240V with Inphase Monitor

Drawing No. A8835

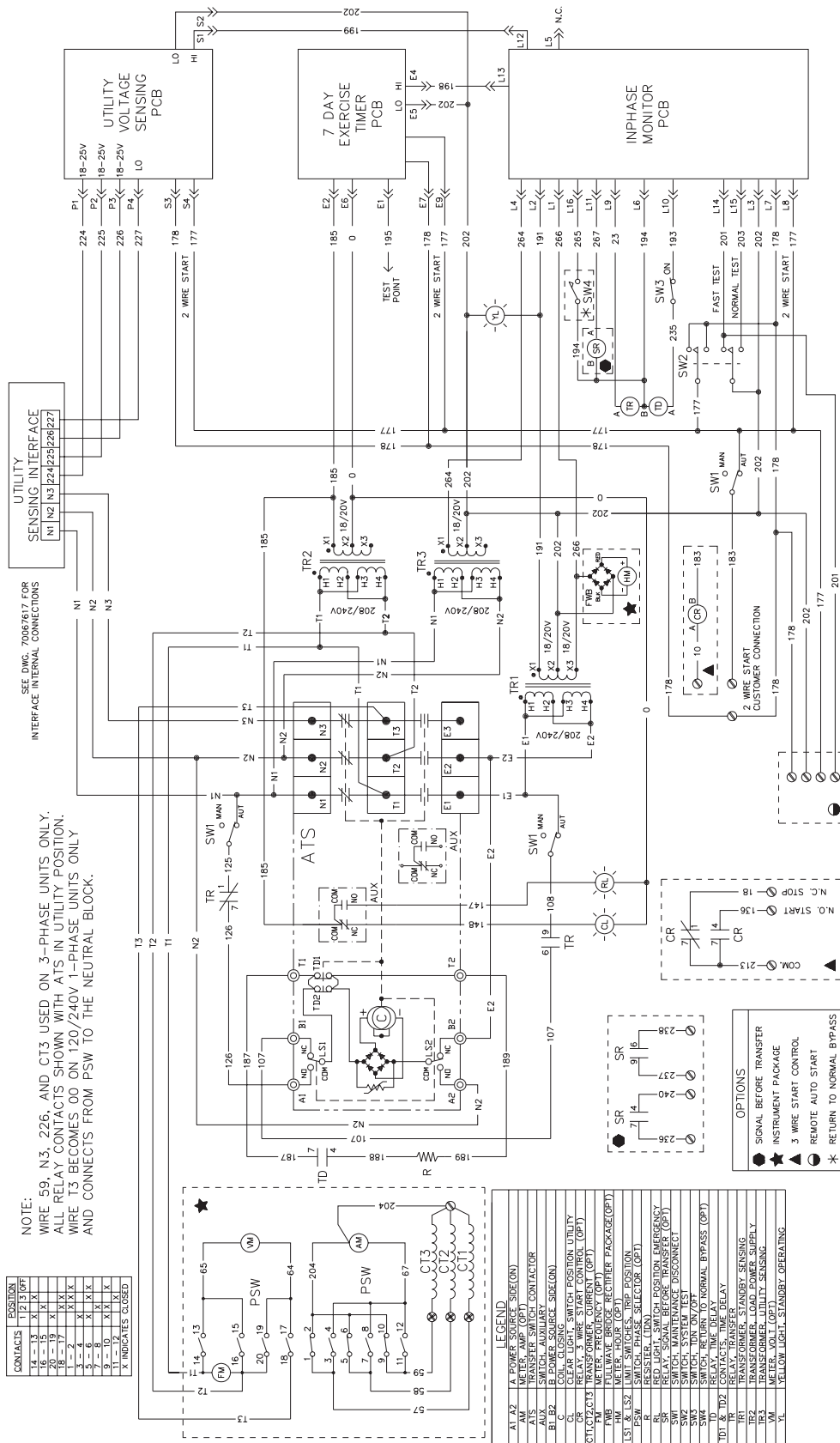

NOTE:
 WIRE 59, N3, 226, AND CT3 USED ON 3-PHASE UNITS ONLY.
 ALL RELAY CONTACTS SHOWN WITH ATS IN UTILITY POSITION.
 WIRE T3 BECOMES 00 ON 120/240V 1-PHASE UNITS ONLY
 AND CONNECTS FROM PSW TO THE NEUTRAL BLOCK.

CONTACTS	POSITION
14	1
15	2
16	3
17	4
18	5
19	6
20	7
21	8
22	9
23	10
24	11
25	12
26	13
27	14
28	15
29	16
30	17
31	18
32	19
33	20
34	21
35	22
36	23
37	24
38	25
39	26
40	27
41	28
42	29
43	30
44	31
45	32
46	33
47	34
48	35
49	36
50	37
51	38
52	39
53	40
54	41
55	42
56	43
57	44
58	45
59	46
60	47
61	48
62	49
63	50
64	51
65	52
66	53
67	54
68	55
69	56
70	57
71	58
72	59
73	60
74	61
75	62
76	63
77	64
78	65
79	66
80	67
81	68
82	69
83	70
84	71
85	72
86	73
87	74
88	75
89	76
90	77
91	78
92	79
93	80
94	81
95	82
96	83
97	84
98	85
99	86
100	87
101	88
102	89
103	90
104	91
105	92
106	93
107	94
108	95
109	96
110	97
111	98
112	99
113	100
114	101
115	102
116	103
117	104
118	105
119	106
120	107
121	108
122	109
123	110
124	111
125	112
126	113
127	114
128	115
129	116
130	117
131	118
132	119
133	120
134	121
135	122
136	123
137	124
138	125
139	126
140	127
141	128
142	129
143	130
144	131
145	132
146	133
147	134
148	135
149	136
150	137
151	138
152	139
153	140
154	141
155	142
156	143
157	144
158	145
159	146
160	147
161	148
162	149
163	150
164	151
165	152
166	153
167	154
168	155
169	156
170	157
171	158
172	159
173	160
174	161
175	162
176	163
177	164
178	165
179	166
180	167
181	168
182	169
183	170
184	171
185	172
186	173
187	174
188	175
189	176
190	177
191	178
192	179
193	180
194	181
195	182
196	183
197	184
198	185
199	186
200	187
201	188
202	189
203	190
204	191
205	192
206	193
207	194
208	195
209	196
210	197
211	198
212	199
213	200
214	201
215	202
216	203
217	204
218	205
219	206
220	207
221	208
222	209
223	210
224	211
225	212
226	213
227	214
228	215
229	216
230	217
231	218
232	219
233	220
234	221
235	222
236	223
237	224
238	225
239	226
240	227
241	228
242	229
243	230
244	231
245	232
246	233
247	234
248	235
249	236
250	237
251	238
252	239
253	240
254	241
255	242
256	243
257	244
258	245
259	246
260	247
261	248
262	249
263	250
264	251
265	252
266	253
267	254
268	255
269	256
270	257
271	258
272	259
273	260
274	261
275	262
276	263
277	264
278	265
279	266
280	267
281	268
282	269
283	270
284	271
285	272
286	273
287	274
288	275
289	276
290	277
291	278
292	279
293	280
294	281
295	282
296	283
297	284
298	285
299	286
300	287
301	288
302	289
303	290
304	291
305	292
306	293
307	294
308	295
309	296
310	297
311	298
312	299
313	300
314	301
315	302
316	303
317	304
318	305
319	306
320	307
321	308
322	309
323	310
324	311
325	312
326	313
327	314
328	315
329	316
330	317
331	318
332	319
333	320
334	321
335	322
336	323
337	324
338	325
339	326
340	327
341	328
342	329
343	330
344	331
345	332
346	333
347	334
348	335
349	336
350	337
351	338
352	339
353	340
354	341
355	342
356	343
357	344
358	345
359	346
360	347
361	348
362	349
363	350
364	351
365	352
366	353
367	354
368	355
369	356
370	357
371	358
372	359
373	360
374	361
375	362
376	363
377	364
378	365
379	366
380	367
381	368
382	369
383	370
384	371
385	372
386	373
387	374
388	375
389	376
390	377
391	378
392	379
393	380
394	381
395	382
396	383
397	384
398	385
399	386
400	387

LEGEND

AT2	A POWER SOURCE SIDE (ON)
ATS	TRANSFER SWITCH CONTACTOR
AUX	SWITCH, AUXILIARY
B2	TRANSFORMER, SECOND SIDE (ON)
CL	COIL
CL	CLEAR LIGHT, SWITCH POSITION, UTILITY
CT1, CT2, CT3	TRANSFORMER, CURRENT (OPT)
FM	METER, FREQUENCY (OPT)
FMB	FULL WAVE BRIDGE RECTIFIER PACKAGE (OPT)
PSW	SWITCH, PHASE SELECTOR (OPT)
SR	RELAY, SIGNAL BEFORE TRANSFER, EMERGENCY
SR	RELAY, SIGNAL BEFORE TRANSFER, DISCONNECT
SW2	SWITCH, SYSTEM TEST
SW3	SWITCH, TID ON / OFF
SW4	SWITCH, TID OFF / ON
T01	SWITCH, TIME DELAY
T02	CONTACTS, TIME DELAY
TR	RELAY, TRANSFER
TR1	TRANSFORMER, UTILITY SENSING
TR2	TRANSFORMER, LOAD POWER SUPPLY
TR3	TRANSFORMER, UTILITY SENSING
VI	MECHANICAL LOCK, STANDBY OPERATING

OPTIONS

●	SIGNAL BEFORE TRANSFER
★	INSTRUMENT PACKAGE
▲	3 WIRE START CONTROL
○	REMOTE AUTO START
✱	RETURN TO NORMAL BYPASS

Section 6 – Wiring Diagrams & Electrical Schematics

Drawing No. A8840

Wiring Diagram - 480/600V with Inphase Monitor

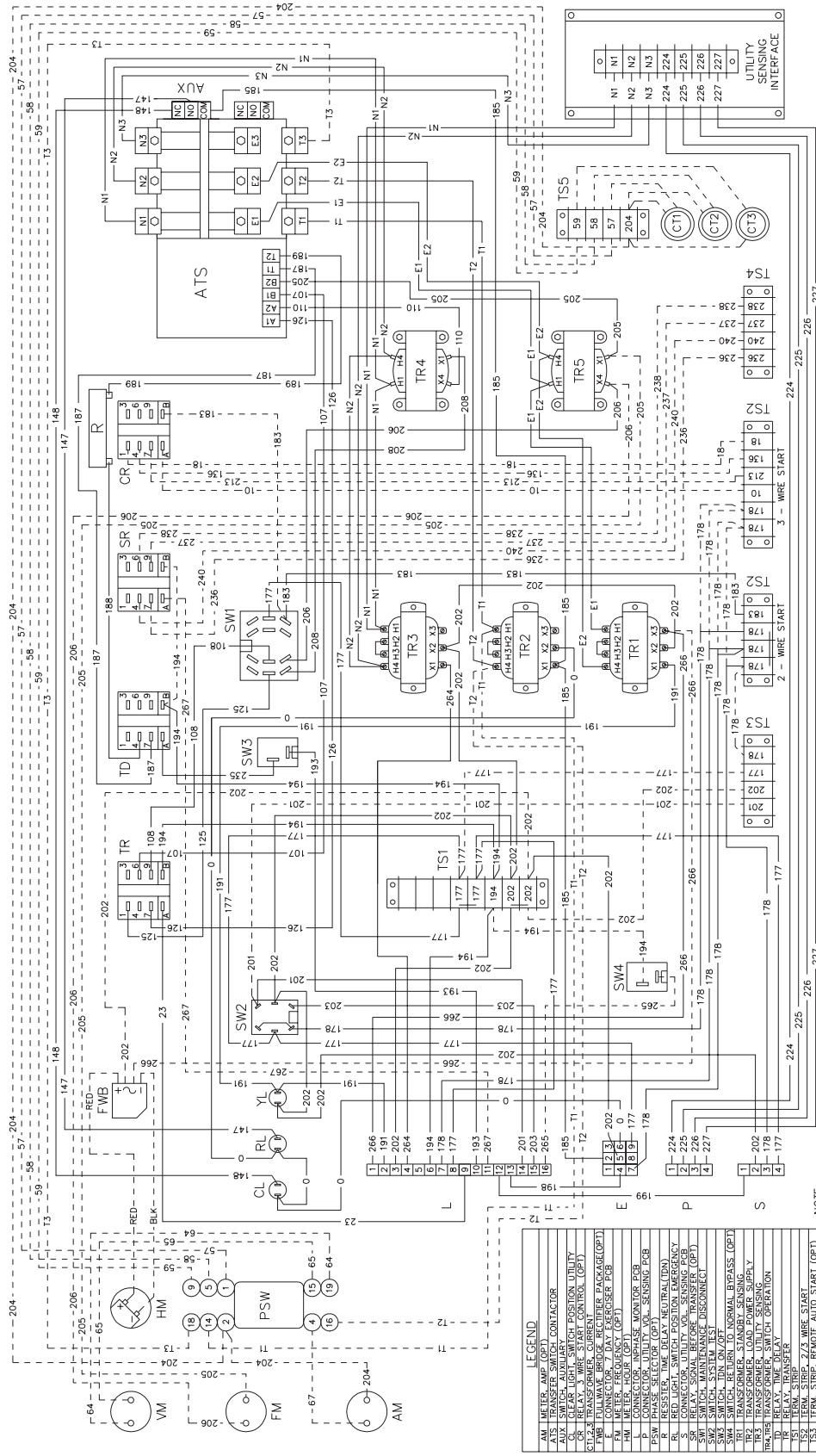
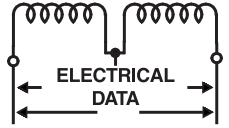

LEGEND

AM	METER, AMP (OPT)
AN	CONTACTOR
AUX	SWITCH, AUXILIARY
CL	CLAR, LIGHT, SWITCH POSITION, UTILITY
CT	CURRENT TRANSFORMER (OPT)
CT1,2,3	TRANSFORMER, CURRENT
F	FULLWAVE BRIDGE RECTIFIER PACKAGE (OPT)
FM	METER, HOUR (OPT)
FM	METER, FREQUENCY (OPT)
P	CONNECTOR, UTILITY, VOL. SENSING PCB
PSW	PHASE SELECTOR (OPT)
R	RELAY
S	CONNECTOR, UTILITY, VOL. SENSING PCB
RL	RELAY, LIGHT, SWITCH POSITION, EMERGENCY
SW1	SWITCH, MANUAL RANGE, DISCONNECT (OPT)
SW2	SWITCH, SYSTEM, ITSI
SW3	SWITCH, RETURN TO, NORMAL, BYPASS (OPT)
TR1	TRANSFORMER, STANDBY SENSING
TR2	TRANSFORMER, LOAD, UTILITY SUPPLY
TR3	TRANSFORMER, TRANSFER, UTILITY SUPPLY
TR4,TR5	TRANSFORMER, SWITCH OPERATION
TS1	TERMINAL STRIP
TS2	TERMINAL STRIP
TS3	TERMINAL STRIP
TS4	TERMINAL STRIP
TS5	TERMINAL STRIP
TS6	TERMINAL STRIP
TS7	TERMINAL STRIP
TS8	TERMINAL STRIP
TS9	TERMINAL STRIP
TS10	TERMINAL STRIP
TS11	TERMINAL STRIP
TS12	TERMINAL STRIP
TS13	TERMINAL STRIP
TS14	TERMINAL STRIP
TS15	TERMINAL STRIP
TS16	TERMINAL STRIP
TS17	TERMINAL STRIP
TS18	TERMINAL STRIP
TS19	TERMINAL STRIP
TS20	TERMINAL STRIP
TS21	TERMINAL STRIP
TS22	TERMINAL STRIP
TS23	TERMINAL STRIP
TS24	TERMINAL STRIP
TS25	TERMINAL STRIP
TS26	TERMINAL STRIP
TS27	TERMINAL STRIP
TS28	TERMINAL STRIP
TS29	TERMINAL STRIP
TS30	TERMINAL STRIP
TS31	TERMINAL STRIP
TS32	TERMINAL STRIP
TS33	TERMINAL STRIP
TS34	TERMINAL STRIP
TS35	TERMINAL STRIP
TS36	TERMINAL STRIP
TS37	TERMINAL STRIP
TS38	TERMINAL STRIP
TS39	TERMINAL STRIP
TS40	TERMINAL STRIP
TS41	TERMINAL STRIP
TS42	TERMINAL STRIP
TS43	TERMINAL STRIP
TS44	TERMINAL STRIP
TS45	TERMINAL STRIP
TS46	TERMINAL STRIP
TS47	TERMINAL STRIP
TS48	TERMINAL STRIP
TS49	TERMINAL STRIP
TS50	TERMINAL STRIP
TS51	TERMINAL STRIP
TS52	TERMINAL STRIP
TS53	TERMINAL STRIP
TS54	TERMINAL STRIP
TS55	TERMINAL STRIP
TS56	TERMINAL STRIP
TS57	TERMINAL STRIP
TS58	TERMINAL STRIP
TS59	TERMINAL STRIP
TS60	TERMINAL STRIP
TS61	TERMINAL STRIP
TS62	TERMINAL STRIP
TS63	TERMINAL STRIP
TS64	TERMINAL STRIP
TS65	TERMINAL STRIP
TS66	TERMINAL STRIP
TS67	TERMINAL STRIP
TS68	TERMINAL STRIP
TS69	TERMINAL STRIP
TS70	TERMINAL STRIP
TS71	TERMINAL STRIP
TS72	TERMINAL STRIP
TS73	TERMINAL STRIP
TS74	TERMINAL STRIP
TS75	TERMINAL STRIP
TS76	TERMINAL STRIP
TS77	TERMINAL STRIP
TS78	TERMINAL STRIP
TS79	TERMINAL STRIP
TS80	TERMINAL STRIP
TS81	TERMINAL STRIP
TS82	TERMINAL STRIP
TS83	TERMINAL STRIP
TS84	TERMINAL STRIP
TS85	TERMINAL STRIP
TS86	TERMINAL STRIP
TS87	TERMINAL STRIP
TS88	TERMINAL STRIP
TS89	TERMINAL STRIP
TS90	TERMINAL STRIP
TS91	TERMINAL STRIP
TS92	TERMINAL STRIP
TS93	TERMINAL STRIP
TS94	TERMINAL STRIP
TS95	TERMINAL STRIP
TS96	TERMINAL STRIP
TS97	TERMINAL STRIP
TS98	TERMINAL STRIP
TS99	TERMINAL STRIP
TS100	TERMINAL STRIP
TS101	TERMINAL STRIP
TS102	TERMINAL STRIP
TS103	TERMINAL STRIP
TS104	TERMINAL STRIP
TS105	TERMINAL STRIP
TS106	TERMINAL STRIP
TS107	TERMINAL STRIP
TS108	TERMINAL STRIP
TS109	TERMINAL STRIP
TS110	TERMINAL STRIP
TS111	TERMINAL STRIP
TS112	TERMINAL STRIP
TS113	TERMINAL STRIP
TS114	TERMINAL STRIP
TS115	TERMINAL STRIP
TS116	TERMINAL STRIP
TS117	TERMINAL STRIP
TS118	TERMINAL STRIP
TS119	TERMINAL STRIP
TS120	TERMINAL STRIP
TS121	TERMINAL STRIP
TS122	TERMINAL STRIP
TS123	TERMINAL STRIP
TS124	TERMINAL STRIP
TS125	TERMINAL STRIP
TS126	TERMINAL STRIP
TS127	TERMINAL STRIP
TS128	TERMINAL STRIP
TS129	TERMINAL STRIP
TS130	TERMINAL STRIP
TS131	TERMINAL STRIP
TS132	TERMINAL STRIP
TS133	TERMINAL STRIP
TS134	TERMINAL STRIP
TS135	TERMINAL STRIP
TS136	TERMINAL STRIP
TS137	TERMINAL STRIP
TS138	TERMINAL STRIP
TS139	TERMINAL STRIP
TS140	TERMINAL STRIP
TS141	TERMINAL STRIP
TS142	TERMINAL STRIP
TS143	TERMINAL STRIP
TS144	TERMINAL STRIP
TS145	TERMINAL STRIP
TS146	TERMINAL STRIP
TS147	TERMINAL STRIP
TS148	TERMINAL STRIP
TS149	TERMINAL STRIP
TS150	TERMINAL STRIP
TS151	TERMINAL STRIP
TS152	TERMINAL STRIP
TS153	TERMINAL STRIP
TS154	TERMINAL STRIP
TS155	TERMINAL STRIP
TS156	TERMINAL STRIP
TS157	TERMINAL STRIP
TS158	TERMINAL STRIP
TS159	TERMINAL STRIP
TS160	TERMINAL STRIP
TS161	TERMINAL STRIP
TS162	TERMINAL STRIP
TS163	TERMINAL STRIP
TS164	TERMINAL STRIP
TS165	TERMINAL STRIP
TS166	TERMINAL STRIP
TS167	TERMINAL STRIP
TS168	TERMINAL STRIP
TS169	TERMINAL STRIP
TS170	TERMINAL STRIP
TS171	TERMINAL STRIP
TS172	TERMINAL STRIP
TS173	TERMINAL STRIP
TS174	TERMINAL STRIP
TS175	TERMINAL STRIP
TS176	TERMINAL STRIP
TS177	TERMINAL STRIP
TS178	TERMINAL STRIP
TS179	TERMINAL STRIP
TS180	TERMINAL STRIP
TS181	TERMINAL STRIP
TS182	TERMINAL STRIP
TS183	TERMINAL STRIP
TS184	TERMINAL STRIP
TS185	TERMINAL STRIP
TS186	TERMINAL STRIP
TS187	TERMINAL STRIP
TS188	TERMINAL STRIP
TS189	TERMINAL STRIP
TS190	TERMINAL STRIP
TS191	TERMINAL STRIP
TS192	TERMINAL STRIP
TS193	TERMINAL STRIP
TS194	TERMINAL STRIP
TS195	TERMINAL STRIP
TS196	TERMINAL STRIP
TS197	TERMINAL STRIP
TS198	TERMINAL STRIP
TS199	TERMINAL STRIP
TS200	TERMINAL STRIP
TS201	TERMINAL STRIP
TS202	TERMINAL STRIP
TS203	TERMINAL STRIP
TS204	TERMINAL STRIP
TS205	TERMINAL STRIP
TS206	TERMINAL STRIP
TS207	TERMINAL STRIP
TS208	TERMINAL STRIP
TS209	TERMINAL STRIP
TS210	TERMINAL STRIP
TS211	TERMINAL STRIP
TS212	TERMINAL STRIP
TS213	TERMINAL STRIP
TS214	TERMINAL STRIP
TS215	TERMINAL STRIP
TS216	TERMINAL STRIP
TS217	TERMINAL STRIP
TS218	TERMINAL STRIP
TS219	TERMINAL STRIP
TS220	TERMINAL STRIP
TS221	TERMINAL STRIP
TS222	TERMINAL STRIP
TS223	TERMINAL STRIP
TS224	TERMINAL STRIP
TS225	TERMINAL STRIP
TS226	TERMINAL STRIP
TS227	TERMINAL STRIP
TS228	TERMINAL STRIP
TS229	TERMINAL STRIP
TS230	TERMINAL STRIP
TS231	TERMINAL STRIP
TS232	TERMINAL STRIP
TS233	TERMINAL STRIP
TS234	TERMINAL STRIP
TS235	TERMINAL STRIP
TS236	TERMINAL STRIP
TS237	TERMINAL STRIP
TS238	TERMINAL STRIP
TS239	TERMINAL STRIP
TS240	TERMINAL STRIP
TS241	TERMINAL STRIP
TS242	TERMINAL STRIP
TS243	TERMINAL STRIP
TS244	TERMINAL STRIP
TS245	TERMINAL STRIP
TS246	TERMINAL STRIP
TS247	TERMINAL STRIP
TS248	TERMINAL STRIP
TS249	TERMINAL STRIP
TS250	TERMINAL STRIP
TS251	TERMINAL STRIP
TS252	TERMINAL STRIP
TS253	TERMINAL STRIP
TS254	TERMINAL STRIP
TS255	TERMINAL STRIP
TS256	TERMINAL STRIP
TS257	TERMINAL STRIP
TS258	TERMINAL STRIP
TS259	TERMINAL STRIP
TS260	TERMINAL STRIP
TS261	TERMINAL STRIP
TS262	TERMINAL STRIP
TS263	TERMINAL STRIP
TS264	TERMINAL STRIP
TS265	TERMINAL STRIP
TS266	TERMINAL STRIP
TS267	TERMINAL STRIP
TS268	TERMINAL STRIP
TS269	TERMINAL STRIP
TS270	TERMINAL STRIP
TS271	TERMINAL STRIP
TS272	TERMINAL STRIP
TS273	TERMINAL STRIP
TS274	TERMINAL STRIP
TS275	TERMINAL STRIP
TS276	TERMINAL STRIP
TS277	TERMINAL STRIP
TS278	TERMINAL STRIP
TS279	TERMINAL STRIP
TS280	TERMINAL STRIP
TS281	TERMINAL STRIP
TS282	TERMINAL STRIP
TS283	TERMINAL STRIP
TS284	TERMINAL STRIP
TS285	TERMINAL STRIP
TS286	TERMINAL STRIP
TS287	TERMINAL STRIP
TS288	TERMINAL STRIP
TS289	TERMINAL STRIP
TS290	TERMINAL STRIP
TS291	TERMINAL STRIP
TS292	TERMINAL STRIP
TS293	TERMINAL STRIP
TS294	TERMINAL STRIP
TS295	TERMINAL STRIP
TS296	TERMINAL STRIP
TS297	TERMINAL STRIP
TS298	TERMINAL STRIP
TS299	TERMINAL STRIP
TS300	TERMINAL STRIP

NOTE:
DASHED LINES REPRESENT WIRING FOR OPTIONAL FEATURES.

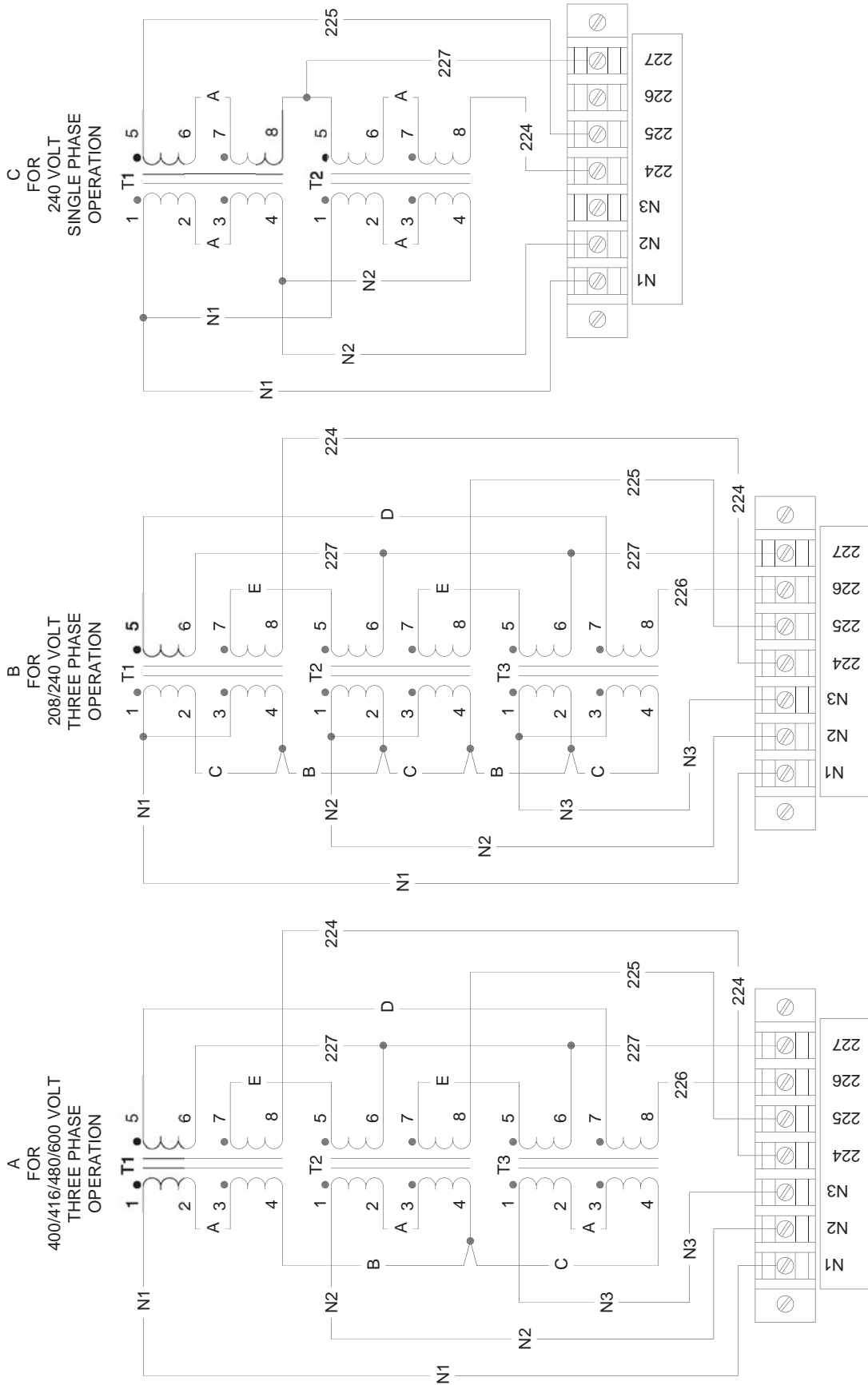
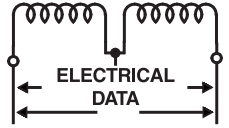

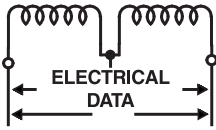

Section 6 – Wiring Diagrams & Electrical Schematics

Schematic - W-Type with Neutral Transfer Switch

Drawing No. A8047-A

- LEGEND**
- C = CLOSING COIL (DUAL COIL BOBBIN)
 - LS1 = SOURCE SELECTING LIMIT SWITCH
 - TD1 = POWER SWITCHING CONTACTS
 - TD2 = POWER SWITCHING CONTACTS
 - AUX1 = AUXILIARY SWITCHES
 - AUX2 = AUXILIARY SWITCHES

WIRE COLORS

- BLU = BLUE WIRE
- YEL = YELLOW WIRE
- RED = RED WIRE
- BLK = BLACK WIRE
- BRN = BROWN WIRE
- GRY = GREY WIRE
- GRN = GREEN WIRE
- DRN = DRANGE WIRE
- WHT = WHITE WIRE
- B/RED = BLUE INSUL. ON TER./ WITH RED WIRE
- B/WHT = BLUE INSUL. ON TER./ WITH WHITE WIRE
- Y/RED = YELLOW INSUL. ON TER./ WITH RED WIRE
- Y/WHT = YELLOW INSUL. ON TER./ WITH WHITE WIRE

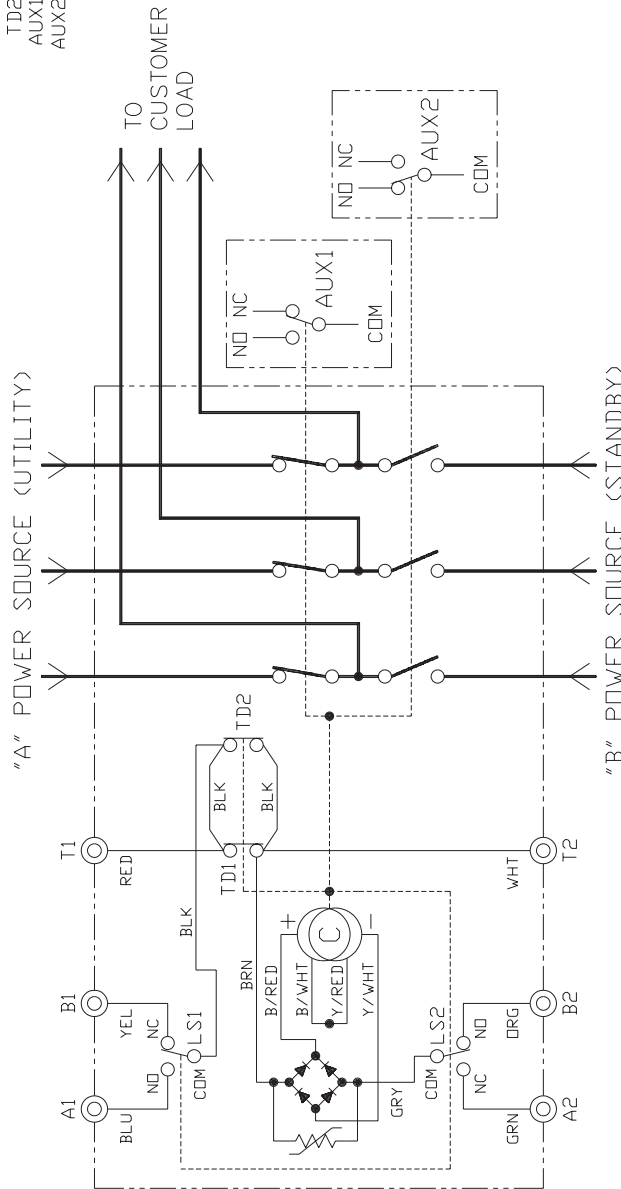

SWITCH POSITION	UTILITY	NEUTRAL	STANDBY
	AUX. 1	CDM-NC X	0
	CDM-ND 0	X	X
AUX. 2	CDM-NC 0	0	X
	CDM-ND X	X	0

X = CLOSED 0 = OPEN

NOTE:
ALL CONTACTS SHOWN WITH MAIN POWER CONTACTS CLOSED IN UTILITY POSITION

Section 7 – Exploded Views and Parts Lists

Transfer Switch Assembly



Drawing No. A9025-C

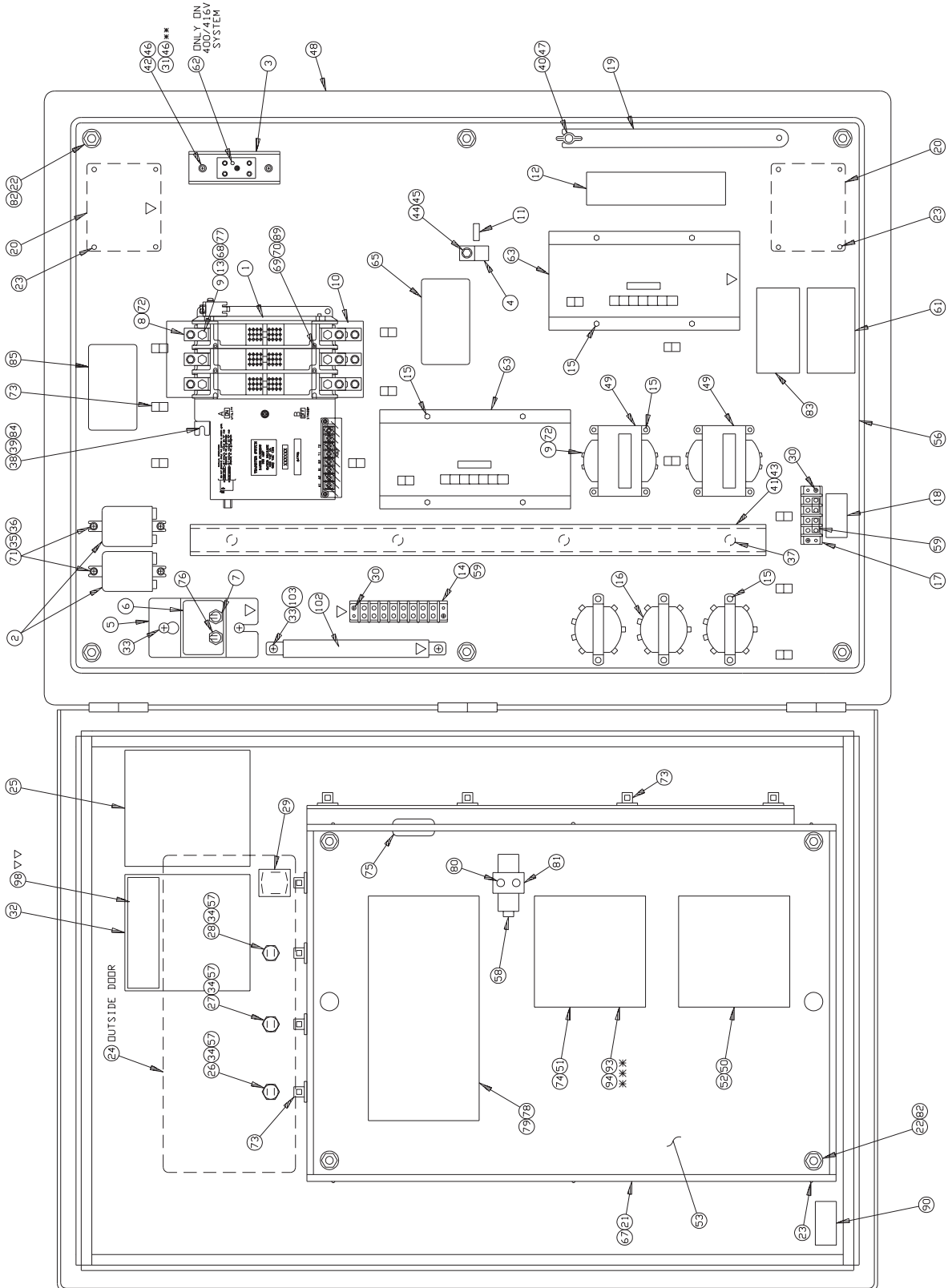



Section 7 – Exploded Views and Parts Lists

Transfer Switch Assembly

Drawing No. A9025-C

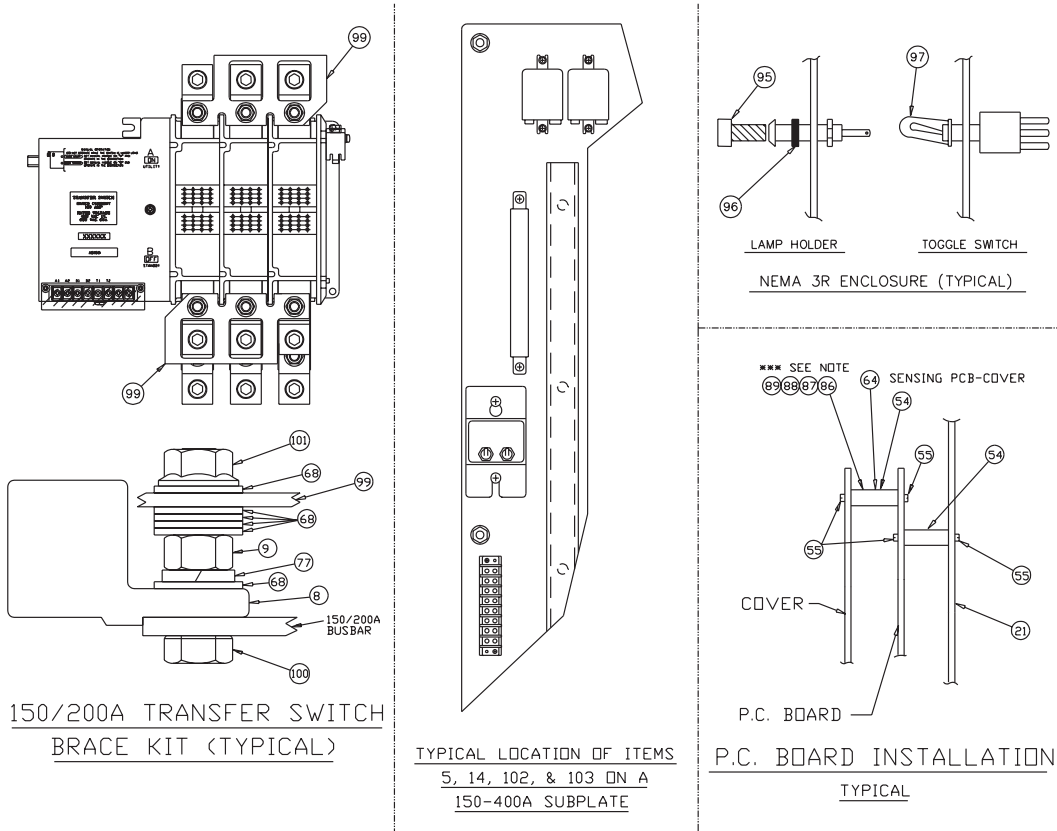

ITEM	PART NO.	QTY.	DESCRIPTION	ITEM	PART NO.	QTY.	DESCRIPTION
1	64772	1	XFER SW-W 100A600V2P	9	22241	-	HEX NUT 3/8-16 (150/200A)
	64773	1	XFER SW-W 100A600V3P	10	73662A	2	LUG COVER 2P 100AMP
	64774	1	XFER SW-W 100A600V4P		73662B	2	LUG COVER 3P 100AMP
	A8185	1	XFER SW-W 150A600V2P		73662C	2	LUG COVER 4P 100AMP
	A8186	1	XFER SW-W 150A600V3P		73662H	2	LUG COV2P 150/200AMP
	A8187	1	XFER SW-W 150A600V4P		73662D	2	LUG COV3P 150/200AMP
	64775	1	XFER SW-W 200A600V2P		73662E	2	LUG COV4P 150/200AMP
	64776	1	XFER SW-W 200A600V3P		73662J	2	LUG COV2P 300/400AMP
	64777	1	XFER SW-W 200A600V4P		73662F	2	LUG COV3P 300/400AMP
	64778	1	XFER SW-W 300A600V2P		73662G	2	LUG COV4P 300/400AMP
	64779	1	XFER SW-W 300A600V3P	11	67210A	1	DECAL-GROUND LUG
	64780	1	XFER SW-W 300A600V4P	12	74525	1	DECAL-MAN OPERATION
	64781	1	XFER SW-W 400A600V2P	13	REF.	-	8M DUAL SIM. SUP. W/XFER SW 100A
	64782	1	XFER SW-W 400A600V3P		29745	-	HHCS 3/8-16 x 1 (150-200A)
	64783	1	XFER SW-W 400A600V4P		A8261	-	HHCS 1/4-28 x 5/8 .625 TH (300-400A)
2	63617	2	RELAY, 12VDC 10A DPDT	14	57701	-	TERM BLK 8POS #6PNL
3	63384	1	LUG, 13/64 4-2/0 TO1 4(100 A)	15	56893	-	CRIMPTIT 10-24 x 1/2
*	63657	1	LUG, 9/32 4-350 TO 6(150-300 A)	16	90975	3	XFRMR-240/40V 25VA
	62633	1	NEUTRAL BLOCK-400 A		95394	3	XFRMR 600/40V 25VA
4	62684	1	LUG 11/32 1-2/0 TO1 4(100 A)	17	46689	-	TERM-BLK 4POS #6PNL
	57329	1	LUG, 13/32 1-350 TO 6(150-400A)	18	91466	1	DECAL 2 WR TERM STRP
5	74509	1	SWITCH BRACKET	19	63321	1	HNDLE XFER SW 1-400A
6	74511	1	DECAL-TDN, MAINT. SW.	20	63578	1	DATA PLATE-GTS
7	55868	1	SWITCH TOGGLE 4PDT	21	68212	1	PCB ENCLOSURE-GTS
8	99084	-	LUG 100 A WN/Y-TYPE(100A)	22	64101	10	NUT LOCKING 3/8-16
	62706	-	LUG 7/16 1-350 TO 6(150/200A)	23	36261	14	POPVRT 1/8 X .23 SSTL
	A7822	-	LUG; 600-4/2; 250-1/0(300/400A)	24	73681	1	DECAL, DOOR GTS

Section 7 – Exploded Views and Parts Lists

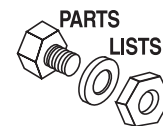

Drawing No. A9025-C

Transfer Switch Assembly

ITEM	PART NO.	QTY.	DESCRIPTION	ITEM	PART NO.	QTY.	DESCRIPTION
	56298	1	DECAL GENERAC 2IN HI		72158	1	INTRFC, 3PHS 600V
25	91478	1	DECAL, SWITCH OPER	64	68337	4	STANDOFF, HEX 1.00 LG
26	57328	1	LAMP LENS-CLEAR	65	54199	1	DECAL, HIGH VOLTAGE
27	57327	1	LAMP LENS-RED	66	64761	-	TIE-WRAP, 5-5/8" LG.
28	57325	1	LAMP LENS-AMBER	67	63981	2	SIDE GUIDE-PCB ENCL
29	55142	1	SWITCH TOGGLE DPDT	68	XXX	N/A	N/A 100A.
30	A1661	4	RIVET, POP .156 D x .5 LG.		22131	-	FLAT WASHER, 3/8" 150-200A.
**31	A2311	2	1/4-20-1" FASTENER		22473	-	FLAT WASHER, 1/4" 300-400A.
32	73619B	1	DECAL-TEST SEQ 100WN	69	BH-45761	4	SUPPORT, SWITCH COVER 150/200A.
	73619C	1	DECAL-TEST SEQ 150-200		BJ-45761	4	SUPPORT, SWITCH CVR 100, 300/400A.
	73619P	1	DECAL-TEST SEQ 300WN				
	73619R	1	DECAL TEST SEQ 400WN	70	63986	4	KNOB, HOLD-DOWN
33	A2111	4	10-32 x 5/16" FASTENER	71	22264	12	WASHER, LOCK #8
34	57514	3	LAMP HOLDER	72	26902	-	SCR., TAPTITE #8-32 x 1/4"
35	38150	4	FLAT WASHER #8-M4	73	63378	31	TIE-DOWN, CABLE
36	A2284	4	8-32 x 1/2 FASTENER	74	63996	1	CVR, EXERCISER CIR. BRD. (STD)
37	91477	5	RIVET, WIRE DUCT MNT		64298	1	CVR, EXERCISER CIR. BRD. (DLX)
38	90388	3	TAPTITE M6-1 x 12LG	75	72252	1	GROMMET
39	49811	3	WASHER FLAT M6	76	28199	1	SWITCH, TIME DELAY NEUTRAL BYPASS
40	58000L	1	TRIC-NUT M6 x 1.0 THD.				
41	91472	1	WRG DUCT 1 x 1.5 6FT(24.25" LG.)	77	XXX	N/A	N/A 100A.
		1	WRG DUCT 1 x 1.5 6FT(33.5" LG.)		22237	-	LOCK WASHER, 3/8" 150-200A
42	A2312	2	10-32 1" FASTENER		22097	-	LOCK WASHER, 1/4" 300-400A
43	91472A	1	WIRE DUCT COVR. 1 IN. (24.25" LG.)	78	92734	1	PCB, IN-PHASE MONITOR
		1	WIRE DUCT COVR. 1 IN. (33.5" LG.)	79	94446	1	COVER, IN-PHASE CONTROL
44	24526	1	TAPTITE 5/16 x 3/4	80	29357	2	RIVET
45	22129	1	LOCK WASHER 5/16-M8	81	63982	1	CLIP, BATTERY
**46	22678	1cc	LOC-TITE THRDLOKR 242	82	22131	10	WASHER, FLAT 3/8"
47	64113	1	M6 x 1.0 STUD WINGNUT	83	83736	1	DECAL, CSA
48	73961	1	ENCL-NEMA 1 100-150A	84	22097	3	WASHER, LOCK M6
	63558	1	NEMA 12 ENCL 100A	85	64510	1	DECAL, TERMINAL NOTE
	73959	1	NEMA 12 ENCL 150-400A	***86	33139	4	SCR., HEX HD. MACH. #6-32 x 3/4"
	73959C	1	ENCL-3R BLK DR 100A	***87	22188	4	NUT, HEX #6-32
	82950	1	NEMA 4 ENCL 100-150Y	***88	22155	4	LOCK WASHER, #6
	64535A	1	4X ENCL 100N&Y 150Y	***89	64210	-	TUBE, NYLON DIA. .17 x .43
	73962	1	ENCL-NEMA 1 2-400A	90	77228	1	DECAL, ENCLOSURE TYPE
	63559	1	NEMA 12 ENCL 200A	91	64153-A	4	WIRE, TRANSFORMER JUMPER (NOT SHOWN)
	73960	1	NEMA 12 ENCL 2-400A				
	73960C	1	ENCL-3R BLK DR2-400A	92	56326	-	TRIM, VINYL 1/8" GAP (NOT SHOWN)
	64540B	1	NEMA 4 150Y&2-400AWN	***93	64861A	1	RED PLEXI 1.5 x 3
	64540A	1	NEMA 4 x 150Y&2-400AWN	***94	64861B	1	RED PLEXI 1.5 x 1
49	64126	2	TRANS 480/240V 200VA	95	72829	3	GASKET-LAMP HOLDER LENS (NEMA 3R)
	72162	2	TRANS 600/240V 200VA				
50	67629	1	ASSY STANDARD SENSNG	96	74548	3	GASKET, LAMP HOLDER (NEMA 3R ENCL)
51	64217	1	ASSY 7-DAY EXERCISER				
	63919	1	ASSY DELUXE EXERCISER	97	72828	1	SWITCH BOOT-WATERPROOF (NEMA 3R)
52	20A67616	1	ASS'Y-STNDSNS CVRPLT				
53	63582	1	DOOR-PCB ENCL	98	95080A	1	DECAL, 600 V RATINGS 100 AMP.
54	64525	20	STAND-OFF HEX 3/4" SP		95080B	1	DECAL, 600 V RATINGS 150/200 A.
55	64526	48	HWHS #6 x 3/8 SELF TAP		95089A	1	DECAL, 600 V RATINGS 300/400 A.
56	A8239	1	SBPLATE 100A W-XFRSW	99	A9059	2	BRACE-150/200A W/WN SW 2-POLE
	A8269	1	SBPL150-400A W-XFRSW		A4753	2	BRACE 150/200A W/WN SW 3-POLE
57	40587	3	LAMP #757 28V 0.08A		A5326	2	BRACE-150/200A W/WN SW 4-POLE
58	63998	1	BATTERY-9V TRANSISTER	100	22746	-	HHC 3/8-16 x 1-3/4
59	46669	-	TERM BLK JUMPER TOP	101	64101	-	NUT, LOCKING 3/8-16
60	A8238	-	HARNESS, 100A W-XFRSW	102	63971	1	RESISTER 250R 5% 100W
	A8267	-	HAR 150-400A W-XFRSW	103	63324	2	MOUNTING BRCKT. #12 FORRES
61	62209	1	UL LABEL E84929-GTS				
62	26902	1	TAPTITE #8-32 x 1/4	*			NOT USED WITH 1-PHASE 3-POLE OR 3-PHASE, 4-POLE SYSTEMS
63	30A67617	1	INTRFC, 3PHS 416/480V	**			USED WITH 150, 200, 300, AND 400 AMP SWITCH
	30B67617	1	INTRFC, 3PHS 208/240V	***			USED ONLY WITH #63919 BOARD
	86961	1	INTRFC, 1PH 240V				
	72160	1	INTRFC, 1P 400V 50/60				

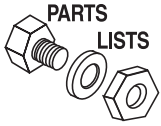

Section 7 – Exploded Views and Parts Lists

240V 1-Phase Interface

Drawing No. 86961M-B

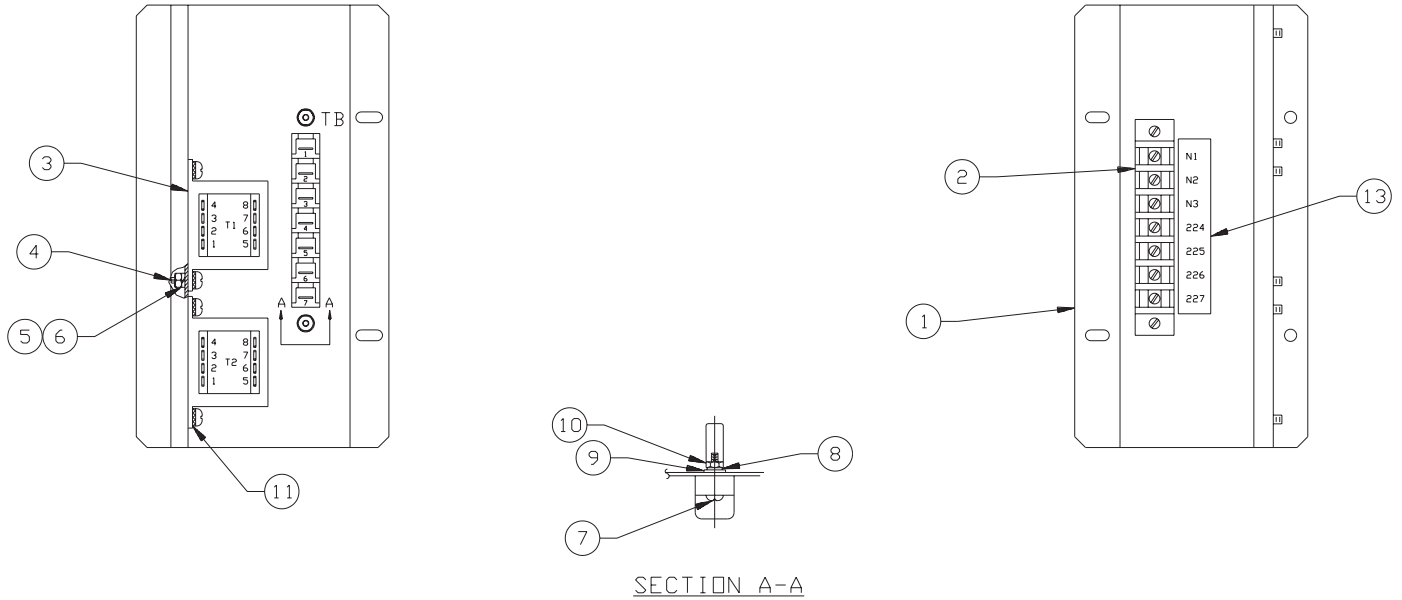

ITEM	PART NO.	QTY.	DESCRIPTION
1	20A67621	1	BRACKET, TRANS MNTG
2	20A67615	1	TERMINAL BLOCK .250
3	20A67614	2	TRNFMR 138.5V/12.5V
4	23965	4	RHMS #8-32 x 3/8
5	22264	4	LOCK WASHER #8-M4
6	22471	4	HEX NUT #8-32
7	33502	2	PHMS #6-32 x 3/4
8	22155	2	LOCK WASHER #6
9	22985	2	FLAT WASHER #6
10	22188	2	HEX NUT #6-32
11	26579	4	SHAKEPROOF EXT. #8
12	55199-A	3.8FT.	WIRE 18 AWG 600V BLU
13	20A67931	1	DECAL, INTRFC

Section 7 – Exploded Views and Parts Lists

Drawing No. 30A67617M-E, 72160M-C,
30B67617M-E & 72158M-C

208V, 240V, 400V, 416V, 480V & 600V 3-Phase Interface

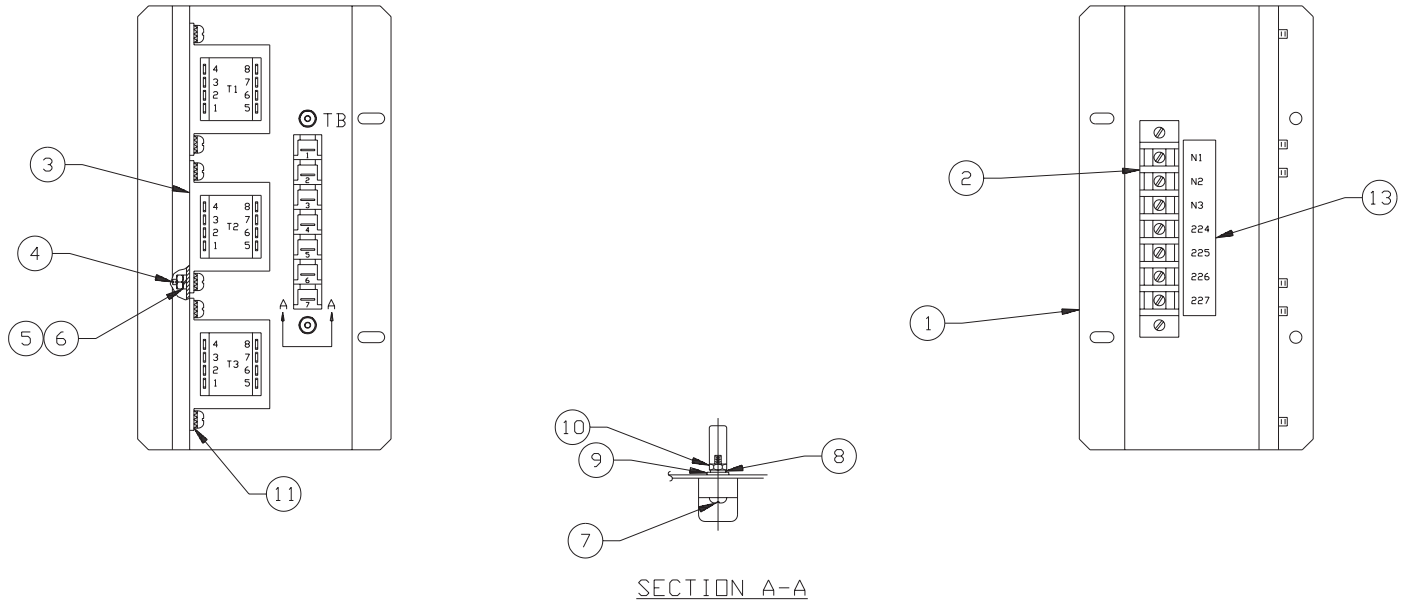
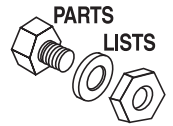

ITEM	PART NO.	QTY.	DESCRIPTION
1	20A67621	1	BRACKET, TRANS MNTG
2	20A67615	1	TERMINAL BLOCK .250
3	*20A67614	3	TRANS 138.5V/12.5V
	**75393	3	TRANS DUAL 120/12.5V
	***75388	3	TRANS DUAL 173/12.5V
4	23965	6	RHMS #8-32 x 3/8
5	22264	6	LOCK WASHER #8-M4
6	22471	6	HEX NUT #8-32
7	33502	2	PHMS #6-32 x 3/4
8	22155	2	LOCK WASHER #6
9	22985	2	FLAT WASHER #6
10	22188	2	HEX NUT #6-32
11	26579	6	SHAKEPROOF EXT #8
12	55199-A	6.2FT.	WIRE 18 AWG 600V BLU
13	20A67931	1	DECAL, INTRFC

USED ON INTERFACE

* 30A67617 & 30B67617

** 72160

*** 72158

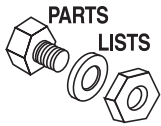

Section 7 – Exploded Views and Parts Lists

Deluxe Exerciser

Drawing No. 64862M

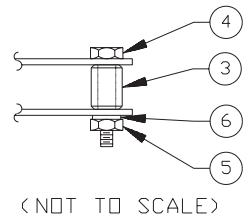
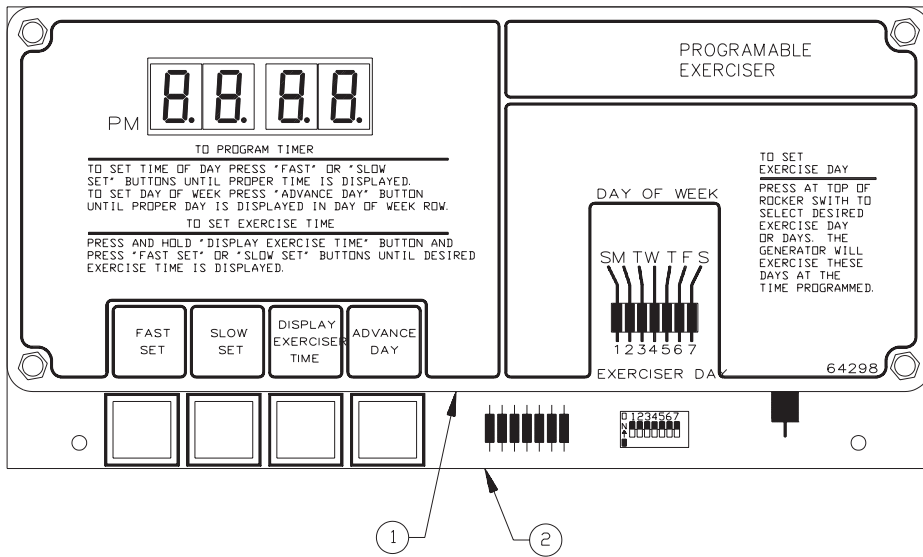

ITEM	PART NO.	QTY.	DESCRIPTION
1	64298	1	COVER PLATE DLX EXER
2	63919	1	ASSY DELUXE EXERCISER
3	64863	4	SPACER 1/4 O.D. x 3/4
4	33139	4	HHMS NUT #6-32 x 3/4
5	22188	4	HEX NUT #6-32
6	22155	4	LOCK WASHER #6



Section 9 – Warranty

Generac GTS "W" Type Transfer Switch

GENERAC POWER SYSTEMS' STANDARD ONE-YEAR LIMITED WARRANTY FOR TRANSFER SWITCH SYSTEMS

NOTE: ALL UNITS MUST BE INSTALLED BY GENERAC POWER SYSTEMS AUTHORIZED SERVICE FACILITIES.

For a period of 1 (one) year of operation from the date of original sale, Generac Power Systems, Inc. (Generac) will, at its option, repair or replace any part which, upon examination, inspection and testing by Generac or a Generac Authorized Warranty Service Facility, is found to be defective under normal use and service, in accordance with the warranty schedule set forth below. Any equipment that the purchaser/owner claims to be defective must be examined by the nearest Generac Authorized Warranty Service Facility. All transportation costs under the warranty, including return to the factory, are to be borne and prepaid by the purchaser/owner. This warranty applies only to Generac transfer switch applications, as Generac has defined transfer switch, provided said transfer switch has been initially installed and inspected on-site by a Generac Authorized Service Dealer or branch thereof.

WARRANTY SCHEDULE

YEAR ONE – 100% (one hundred percent) coverage on mileage*, labor and parts listed:

- **Transfer System** – All components

**Travel allowance is limited to 300 miles or 7.5 hours maximum, round trip, and applies only to permanently wired and mounted units.*

All warranty expense allowances **are** subject to the conditions defined in Generac's *Warranty Policies, Procedures and Flat Rate Manual*.

Units that have been resold **are not** covered under the Generac warranty, as this warranty is not transferable.

THIS WARRANTY SHALL NOT APPLY TO THE FOLLOWING:

- Costs of normal maintenance, adjustments, installation and start-up.
- Failures due, but not limited, to normal wear and tear, accident, misuse, abuse, negligence or improper installation.
- Failures caused by any external cause or act of God, such as collision, theft, vandalism, riot or wars, nuclear holocaust, fire, freezing, lightning, earthquake, windstorm, hail, volcanic eruption, water or flood, tornado or hurricane.
- Products that are modified or altered in a manner not authorized by Generac in writing.
- Any incidental, consequential or indirect damages caused by defects in materials or workmanship, or any delay in repair or replacement of the defective part(s).
- Failure due to misapplication.
- Telephone, telegraph, teletype or other communication expenses.
- Living or travel expenses of person(s) performing service, except as specifically included within the terms of a specific unit warranty period.
- Rental equipment used while warranty repairs are being performed.
- Overnight freight costs for replacement part(s).
- Overtime labor.
- Fuses and light bulbs.

THIS WARRANTY IS IN PLACE OF ALL OTHER WARRANTIES, EXPRESSED OR IMPLIED. SPECIFICALLY, GENERAC MAKES NO OTHER WARRANTIES AS TO THE MERCHANTABILITY OR FITNESS FOR A PARTICULAR PURPOSE. Some states do not allow limitations on how long an implied warranty lasts, so the above limitation may not apply to you.

GENERAC'S ONLY LIABILITY SHALL BE THE REPAIR OR REPLACEMENT OF PART(S) AS STATED ABOVE. IN NO EVENT SHALL GENERAC BE LIABLE FOR ANY INCIDENTAL OR CONSEQUENTIAL DAMAGES, EVEN IF SUCH DAMAGES ARE A DIRECT RESULT OF GENERAC'S NEGLIGENCE. Some states do not allow the exclusion or limitation of incidental or consequential damages, so the above limitation may not apply to you. Purchaser/owner agrees to make no claims against Generac based on negligence.

This warranty gives you specific legal rights. You also may have other rights that vary from state to state.