

GENERAC[®]

POWER SYSTEMS, INC.

Owner's Manual



Integrated Load Center

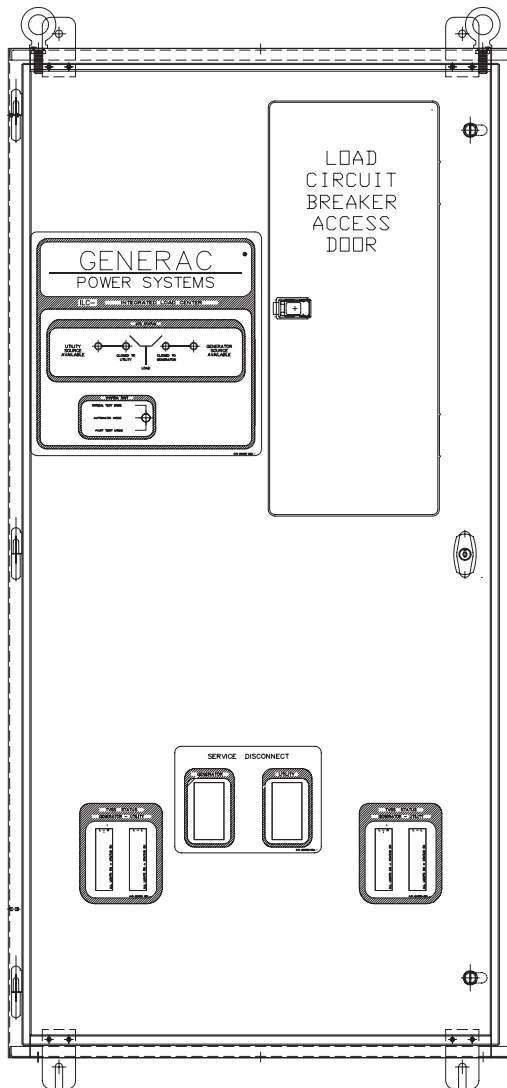

200 Amp, 600 Volts



This manual should remain with the unit.



 **Read the following information carefully before attempting to install, operate or service this equipment. Also read the instructions and information on tags, decals, and labels that may be affixed to the transfer switch. Replace any decal or label that is no longer legible.** 

 **DANGER! Connection of a generator to an electrical system normally supplied by an electric utility shall be by means of suitable transfer equipment so as to isolate the electric system from utility distribution system when the generator is operating (Article 702 Optional Standby Systems, as applicable). Failure to isolate electric system by these means may result in damage to generator and may result in injury or death to utility workers due to backfeed of electrical energy.** 

Generac cannot possibly anticipate every possible circumstance that might involve a hazard. The warnings in this manual, and on tags and decals affixed to the unit are, therefore, not all-inclusive. If you use a procedure, work method or operating technique Generac does not specifically recommend, you must satisfy yourself that it is safe for you and others. Also make sure the procedure, work method or operating technique chosen does not render the transfer switch unsafe.

Throughout this publication, and on tags and decals affixed to the generator, DANGER, WARNING, CAUTION and NOTE blocks are used to alert personnel to special instruction about a particular operation that may be hazardous if performed incorrectly or carelessly. Observe them carefully. Their definitions are as follows:

—  **DANGER**  —

After this heading, read instructions that, if not strictly complied with, will result in personal injury or property damage.

—  **WARNING**  —

After this heading, read instructions that, if not strictly complied with, may result in personal injury or property damage.

—  **CAUTION**  —

After this heading, read instructions that, if not strictly complied with, could result in damage to equipment and/or property.

NOTE:

After this heading, read explanatory statements that require special emphasis.

These safety warnings cannot eliminate the hazards that they indicate. Common sense and strict compliance with the special instructions while performing the service are essential to preventing accidents.

Four commonly used safety symbols accompany the DANGER, WARNING and CAUTION blocks. The type of information each indicates follows:

 This symbol points out important safety information that, if not followed, could endanger personal safety and/or property of others.

 This symbol points out potential explosion hazard.

 This symbol points out potential fire hazard.

 This symbol points out potential electrical shock hazard.

 **GENERAL HAZARDS** 

- Any AC generator that is used for backup power if a NORMAL (UTILITY) power source failure occurs, must be isolated from the NORMAL (UTILITY) power source by means of an approved transfer switch. Failure to properly isolate the NORMAL and STANDBY power sources from each other may result in injury or death to electric utility workers, due to backfeed of electrical energy.
- Improper or unauthorized installation, operation, service or repair of the equipment is extremely dangerous and may result in death, serious personal injury, or damage to equipment and/or personal property.
- Extremely high and dangerous power voltages are present inside an installed transfer switch. Any contact with high voltage terminals, contacts or wires will result in extremely hazardous, and possibly LETHAL, electric shock. **DO NOT WORK ON THE TRANSFER SWITCH UNTIL ALL POWER VOLTAGE SUPPLIES TO THE SWITCH HAVE BEEN POSITIVELY TURNED OFF.**
- Competent, qualified personnel should install, operate and service this equipment. Adhere strictly to local, state and national electrical and building codes. When using this equipment, comply with regulations the National Electrical Code (NEC), CSA Standard; C22.1 Canadian Electric Code and Occupational Safety and Health Administration (OSHA) have established.
- Never handle any kind of electrical device while standing in water, while barefoot, or while hands or feet are wet. **DANGEROUS ELECTRICAL SHOCK MAY RESULT.**

- Because jewelry conducts electricity, wearing it may cause dangerous electrical shock. Remove all jewelry (such as rings, watches, bracelets, etc.) before working on this equipment.
- If working on this equipment while standing on metal or concrete, place insulative mats over a dry wood platform. Work on this equipment only while standing on such insulative mats.
- Never work on this equipment while physically or mentally fatigued.
- Keep the transfer switch enclosure door closed and bolted at all times. Only qualified personnel should be permitted access to the switch interior.
- In case of an accident caused by electric shock, immediately shut down the source of electrical power. If this is not possible, attempt to free the victim from the live conductor but **AVOID DIRECT CONTACT WITH THE VICTIM**. Use a nonconducting implement, such as a rope or board, to free the victim from the live conductor. If the victim is unconscious, apply first aid and get immediate medical help.
- When an automatic transfer switch is installed for a standby generator set, the generator engine may crank and start at any time without warning. To avoid possible injury that might be caused by such sudden start-ups, the system's automatic start circuit must be disabled before working on or around the generator or transfer switch. For that purpose, a **SAFETY DISCONNECT** is provided inside the transfer switch. Always set that switch to its **MANUAL** position before working on the equipment. Then place a "DO NOT OPERATE" tag on the transfer switch and on the generator.

Safety RulesInside Front Cover-1

Section 1 – General Information2

1.1 Introduction2

1.2 Equipment Description2

1.3 Transfer Mechanism.....3

1.4 Ratings — Data Plate3

1.5 Panel Board Enclosure4

1.6 Safe Use of Panel Board4

Section 2 – Installation4

2.1 Introduction to Installation.....4

2.2 Unpacking4

2.3 Mounting4

2.4 Connecting Power Source and Load Lines4

2.5 Connecting Start Circuit Wires5

2.6 Auxiliary Contacts6

2.7 Time Delay Neutral On-Off Switch6

Section 3 – Operation7

3.1 Functional Tests & Adjustments7

3.2 Manual Operation.....7

3.3 Voltage Checks8

3.4 Electrical Operation9

3.5 Main Contacts at Normal (Utility)9

3.6 Main Contacts at Neutral10

3.7 Main Contacts at Standby (Emergency)10

3.8 Switches and Advisory Lamps10

3.9 System Test Switch.....10

3.10 Source Available LED11

3.11 Switch Position LED.....11

3.12 Sequence of Operation11

3.13 Sensor and Timer Adjustments -
Sensing Circuit Board12

3.14 Sequence of Operation Settings13

3.15 Adjustments On Inphase Monitor
Control Circuit Board.....14

3.16 Calibrating the Inphase Monitor
Control Circuit Board.....16

3.17 Circuit Board Switch SW116

3.18 Exercise Timer Display.....17

3.19 Exercise Times18

3.20 Pushbuttons18

3.21 Programming Examples18

Section 4 – Maintenance19

4.1 Operate Transfer Switch.....19

4.2 Clean and Inspect Transfer Switch.....19

4.3 Lubrication19

4.4 Main Current Carrying Contacts.....19

4.5 Nine-Volt Battery.....19

Section 5 – Installation Diagram20

Section 6 – Electrical Data.....22

Section 7 – Exploded Views & Parts Lists26

Section 8 – Warranty.....Back Cover

1.1 INTRODUCTION

This manual has been prepared especially for the purpose of familiarizing personnel with the design, application, installation, operation and servicing of the applicable equipment. Read the manual carefully and comply with all instructions. This will help to prevent accidents or damage to equipment that might otherwise be caused by carelessness, incorrect application, or improper procedures.

Every effort has been expended to make sure that the contents of this manual are both accurate and current. Generac, however, reserves the right to change, alter or otherwise improve the product at any time without prior notice.

1.2 EQUIPMENT DESCRIPTION

This Integrated Load Center (ILC) is a combination of individual components that perform four basic functions.

◆ 1.2.1 SERVICE DISCONNECT

This unit is equipped with a 200 amp circuit breaker for each source of supply, UTILITY and GENERATOR. This circuit breaker can serve as the service disconnect for each of the supplies.

◆ 1.2.2 TRANSIENT VOLTAGE SURGE SUPPRESSION (TVSS)

The TVSS is provided to protect the load from electrical surges and/or transient voltage spikes. This device is physically located next to the service disconnect circuit breakers and electrically connected to the load side of the service disconnect. A TVSS module is always supplied to protect the utility supply; the generator supply TVSS protection is provided in some models. A 30 amp circuit breaker is provided to disconnect the TVSS from the live ILC for maintenance or replacement.

The TVSS is made up of multiple solid state Metal Oxide Varistors (MOV) connected in parallel for each mode of protection. These devices are equipped with integrated short circuit and individual component level fusing. They are self-resetting and fully automatic.

◇ 1.2.2.1 Modes of Protection

The TVSS provides protection on all modes:

- Single Phase (6) - L-L, L-N, L-N, L-G, L-G and N-G.
- Three Phase (10) - L-L, L-L, L-L, L-N, L-N, L-N, L-G, L-G, L-G and N-G.

◇ 1.2.2.2 Ratings

- Surge Capacity: 88 kA per mode.
- Suppression Level (typical):
 - L-N = 330 V
 - L-G = 400 V
 - N-G = 400V
 - L-L = 700 V

◇ 1.2.2.3 Certification

The TVSS is UL recognized to the requirements of UL 1449 2nd edition.

◇ 1.2.2.4 TVSS Disconnect

Each TVSS is provided with a disconnect. The disconnect is a 30 amp circuit breaker, 2-pole for single phase and 3-pole for three phase. This is to allow replacement of the TVSS module without interruption of the electrical supply to the load.



 **REPLACEMENT OF THE TVSS MODULE WHILE THE ATS - ILC IS ENERGIZED SHOULD ONLY BE PERFORMED BY A QUALIFIED ELECTRICIAN.**



 **BE SURE TO TURN ON TVSS DISCONNECT CIRCUIT BREAKER WHEN THE PROCEDURE IS COMPLETE. IF THE CIRCUIT BREAKER IS NOT TURNED ON THE TVSS MODULE WILL NOT PROVIDE ANY SURGE PROTECTION FOR THE CUSTOMER LOAD.**

◇ 1.2.2.5 STATUS INDICATORS

Each TVSS module is equipped with a set of LED indicators that are on the cover of the individual module. The LED's are connected internally to indicate that the mode of protection is in working order and providing the indicated mode of protection. The LED's are on when the mode of protection is available and the power source is also available. For the power source to be available, the associated service disconnect circuit breaker must be ON, the associated TVSS disconnect circuit breaker must be ON and the associated source must be present.

The LED status indicators can be viewed from the outside of the enclosure or directly on the TVSS module with the enclosure door open. All four (4) LED's (single phase) or all six (6) LED's (three phase) should be on to indicate the TVSS module is ready to provide protection against surge voltages.

◇ 1.2.2.6 REMOTE ALARM CONTACTS

Each TVSS module is equipped with a set of alarm contacts. These alarm contacts are wired to a two-position terminal strip adjacent to the TVSS module. The internal contacts are normally closed to indicate normal operation. If one of the protection elements should become damaged, the contacts will open, indicating the failure.

Contacts are rated 2A @ 125 VAC.

◆ 1.2.3 AUTOMATIC TRANSFER SWITCH

The automatic transfer switch is used for transferring critical electrical load from a NORMAL (UTILITY) power source to a STANDBY (EMERGENCY) power source. Such a transfer of electrical loads occurs automatically when the NORMAL power source has failed or is substantially reduced and the STANDBY source voltage and frequency have reached an acceptable level. The transfer switch prevents electrical feedback between two different power sources (such as the NORMAL and STANDBY sources) and, for that reason, codes require it in all standby electric system installations.

The transfer switch consists of a solid state intelligence circuit, a transfer mechanism and a control panel.

◆ 1.2.4 PANEL BOARD

This unit is provided with a 42 position panel board (manufactured by Siemens) for mounting of individual branch circuit breakers. Single phase ILC's are equipped with a single phase panelboard. Three phase ILC's are equipped with a three phase panel board. It is factory wired and the customer connection is made here.

◇ 1.2.4.1 Voltage Rating

- 240 Volt maximum when used with BL, BLH, and QJH2 branch circuit breakers.

◇ 1.2.4.2 Amperage Rating

The panel interior has been tested to 250 amps, however is limited to 200 amp in this application. The limitation comes from the service disconnect circuit breakers ratings.

◇ 1.2.4.3 Recommended Circuit Breakers

- Only circuit breakers manufactured by Siemens Energy & Automation, Inc.
- This panel board is UL component recognized only when used with Siemens type BL, BLH, or QJH2 and at a suitable current rating for the branch circuit.
- Blank covers must be installed in all open spaces (no circuit breaker installed), before putting the system in service. Use ONLY Siemens catalog number QF-3.

1.3 TRANSFER MECHANISM

- The transfer mechanism houses the main, current carrying contacts, along with other mechanical and electrical components required for operating the switch (Figure 1.1). Main contacts are actuated by a single solenoid, are electrically operated and mechanically held. Power for that coil's operation is taken from the side to which the LOAD is being transferred. Thus, transfer to any power source cannot occur unless that power source is available to the switch.
- LOAD (or "T") contacts are bolted to an insulated plastic pole piece and are stationary. The NORMAL (UTILITY) and STANDBY (EMERGENCY) contacts are moveable. The contacts are actuated by means of a closing coil and mechanical linkage. The pole assemblies which retain the stationary moveable main contacts are assembled together and retained by through-bolts. Either 2, 3 or 4-pole assemblies may be used to form a 2, 3 or 4-pole mechanism.

Figure 1.1 — The Transfer Mechanism

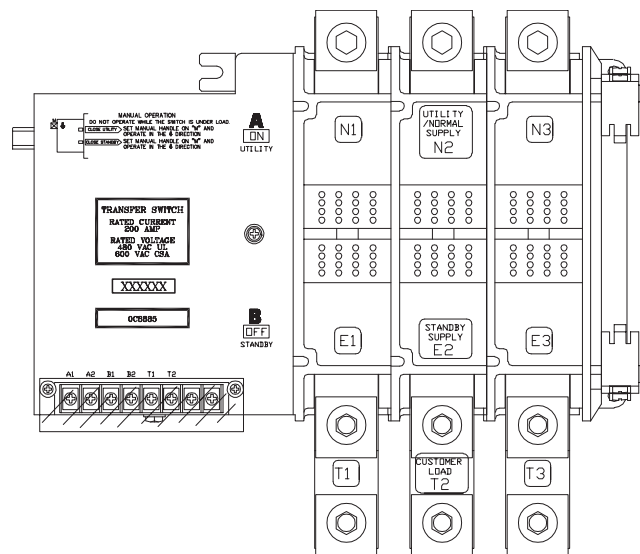

1.4 RATINGS – DATA PLATE

This ILC is rated 200 amp at 120/240 or 120/208 VAC single phase or 120/208 VAC three phase. A DATA PLATE is permanently affixed to the transfer switch subplate. Use this ILC only within the specific limits shown on the DATA PLATE and the application decal located on the inside lower left side of the cabinet.

When requesting information or ordering parts for this equipment, make sure to include all information from the DATA PLATE. Record the Model and Serial numbers in the space provided on the top of page 4 for future reference.

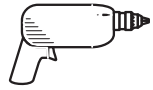

MODEL #
SERIAL #

1.5 PANEL BOARD ENCLOSURE

The standard switch enclosure is a National Electrical Manufacturer’s Association (NEMA) 1 type. NEMA 1 type enclosures primarily provide protection against contact with the enclosed equipment and against a limited amount of falling dirt.

1.6 SAFE USE OF PANEL BOARD

Before installing, operating or servicing this equipment, read the SAFETY RULES (inside front cover) carefully. Comply strictly with all SAFETY RULES to prevent accidents and/or damage to the equipment. Generac recommends making a copy of the SAFETY RULES and post them near the transfer switch. Also, be sure to read all instructions and information found on tags, labels and decals affixed to the equipment.

Three publications that outline the safe use of transfer switches are the following:

- NFPA 70; National Electrical Code
- UL 1008, STANDARD FOR SAFETY-AUTOMATIC TRANSFER SWITCHES
- UL 67, STANDARD FOR SAFETY-PANEL BOARDS

2.1 INTRODUCTION TO INSTALLATION

This equipment has been wired and tested at the factory. Installing the switch includes the following procedures:

- Unpacking the ILC.
- Mounting the enclosure.
- Connecting power source and load leads.
- Connecting the generator start circuit.
- Connecting any auxiliary contact (if needed)
- Installing/connecting any options and accessories.
- Testing functions.

2.2 UNPACKING

Carefully unpack the transfer switch. Inspect closely for any damage that might have occurred during shipment. The purchaser must file with the carrier any claims for loss or damage incurred while in transit.

Check that all packing material is completely removed from the switch prior to installation.

Attach any lifting device to the lifting eyes on top of the enclosure. **DO NOT LIFT THE SWITCH AT ANY OTHER POINT.**



CAUTION
 The ILC transfer switch weighs about 350 pounds. **DO NOT** attempt to lift without the proper equipment.

2.3 MOUNTING

Mounting dimensions for the transfer switch enclosure are in this manual. This enclosure is configured for wall-mounting. This enclosure is a NEMA/UL 1-type design, suitable for indoor installation only.



CAUTION
 Handle transfer switches carefully when installing. **Do not drop the switch. Protect the switch against impact at all times, and against construction grit and metal chips. Never install a transfer switch that has been damaged.**

Install the transfer switch as close as possible to the electrical loads that are to be connected to it. Mount the switch vertically to a rigid supporting structure. To prevent switch distortion, level all mounting points. If necessary, use washers behind mounting holes to level the unit.

2.4 CONNECTING POWER SOURCE AND LOAD LINES



DANGER
 Make sure to turn **OFF** both the **NORMAL (UTILITY)** and **STANDBY (GENERATOR)** power supplies before connecting to the power source and load lines to the transfer switch. **Supply voltages are extremely high and dangerous. Contact with such high voltage power supply lines causes extremely hazardous, possibly lethal, electrical shock.**

Wiring diagrams and electrical schematics are provided in this manual. Power source connections are made at the service disconnect circuit breakers located near the bottom of the enclosure. The individual load connections will be made at the panel board, inside the switch enclosure.

2.4.1 2 & 3-POLE MECHANISM

This switch (Figure 2.1) is used with a three phase system when **NEUTRAL** is not to be switched. The two pole switch is similar in construction with the N3, E3 and T3 pole removed.

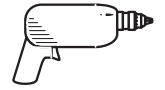
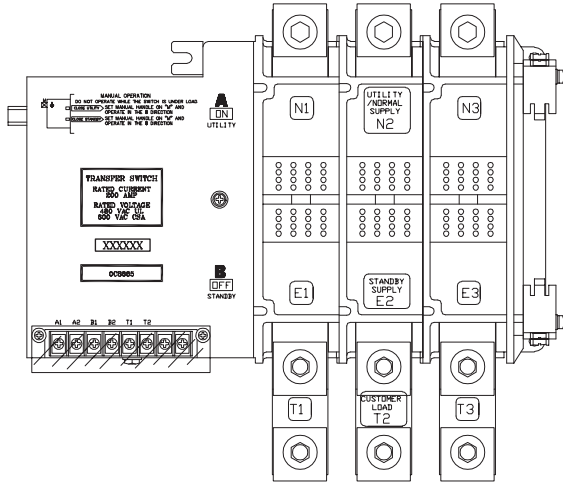

Figure 2.1 — Typical 3-Pole Transfer Mechanism (200 Amp Shown)



⚠ CAUTION ⚠

⚠ Use a torque wrench to tighten the conductors, being sure not to overtighten, or damage to the switch base could occur. If undertightened, a loose connection would result, causing excess heat which could damage the switch base.

Terminal Lug	Wire Range	Torque Value
Circuit Breaker	CU 2/0 AWG - 300 kcmil	250 in-lbs.
	AL 4/0 AWG - 300 kcmil	250 in-lbs.
Neutral Lug	#6 AWG - 350 kcmil	375 in-lbs.
Ground	#8 AWG	40 in-lbs.
	#4 - #6 AWG	45 in-lbs.
	#2 AWG	50 in-lbs.
Branch circuit breakers	Will vary with the size of the individual circuit breaker.	Consult the marking on the circuit breaker.

Be sure to maintain proper electrical clearance between live metal parts and grounded metal. Allow at least 1/2 inch for 100-400 amp circuits.

⚠ DANGER ⚠

⚡ All power voltage supplies must be turned off before connecting to the power source and load lines. Failure to turn off power voltage supplies will result in extremely dangerous and possibly lethal electrical shock.

All power cables should enter the switch next to the service disconnect circuit breaker terminals. Standard terminal lugs on the service disconnect are solderless, screw-type.

Connect power source and load conductors to clearly marked terminal lugs on the ILC as follows:

- LOAD leads: Connect to individual branch circuit breaker terminals.
- NORMAL (UTILITY) Source Leads: Connect to service disconnect circuit breaker.
- STANDBY (EMERGENCY) Source Leads: Connect to service disconnect circuit breaker.

Conductor sizes must be adequate to handle the maximum current to which they will be subjected, based on the 75°C column of tables, charts, etc. used to size conductors. The installation must comply fully with all applicable codes, standards and regulations.

Before connecting wiring cables to terminals, remove any surface oxides from the cable ends with a wire brush. If ALUMINUM conductors are used, apply corrosion inhibitor to conductors. After tightening terminal lugs, carefully wipe away any excess corrosion inhibitor.

Tighten terminal lugs to the torque values as noted inside the transfer switch door.

2.5 CONNECTING START CIRCUIT WIRES

Connect suitable, approved wiring to transfer switch terminals 178 and 183 (see chart below). Route these wires through suitable, approved individual conduit and connect to identically numbered terminals in the AC connection (lower) panel of the generator set. See Figure 2.2 on page 6.

Closure of Wire 178 and 183 circuit by switch circuit action must result in generator engine cranking and startup.

Recommended wire gauge sizes for this wiring depends on the length of the wire, as recommended below:

MAXIMUM WIRE LENGTH	RECOMMENDED WIRE SIZE
460 feet (140m)	No. 18 AWG.
461 to 730 feet (223m)	No. 16 AWG.
731 to 1,160 feet (354m)	No. 14 AWG.
1,161 to 1,850 feet (565m)	No. 12 AWG.

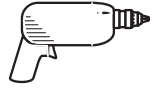

2.6 AUXILIARY CONTACTS

There is access to Auxiliary Contacts on the transfer switch to operate customer accessories, remote advisory lights, or remote annunciator devices. A suitable power source must be connected to the COMMON (C) terminal. The contacts shown as FACTORY in Figure 2.3 are connected at the factory for operating transfer switch advisory lights. The contacts shown as auxiliary are available for customer use.

Contact operation is shown in the following chart:

	Switch Position	
	Utility	Standby
Common to Normally Open	Closed	Open
Common to Normally Closed	Open	Closed

NOTE:

Auxiliary Contacts are rated 10 amps at 125 or 250 volts AC. DO NOT EXCEED THE RATED VOLTAGE AND CURRENT OF THE CONTACTS.

2.7 TIME DELAY NEUTRAL ON-OFF SWITCH (FIGURE 2.4)

The Time Delay Neutral feature extends the time that the main contacts normally disconnect the load from both sources. By permitting the LOAD to remain disconnected from both power sources for a fixed time setting, residual voltages generated by heavy inductive loads will decay to a safe level before reconnecting. This provides some protection against nuisances such as blown fuses or tripped circuit breakers that otherwise might occur during a rapid transfer of motor and other heavy inductive loads.

Units with the Time Delay Neutral feature are equipped with a Time Delay On/Off switch. To eliminate the time delay at neutral during a transfer action, set the switch to OFF.

Figure 2.4 — Time Delay Neutral Switch

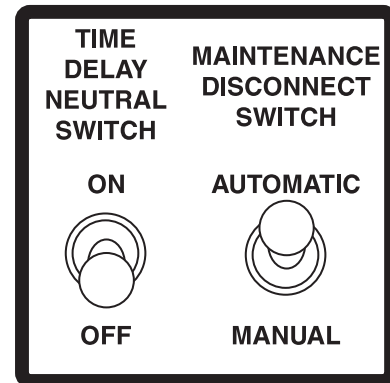
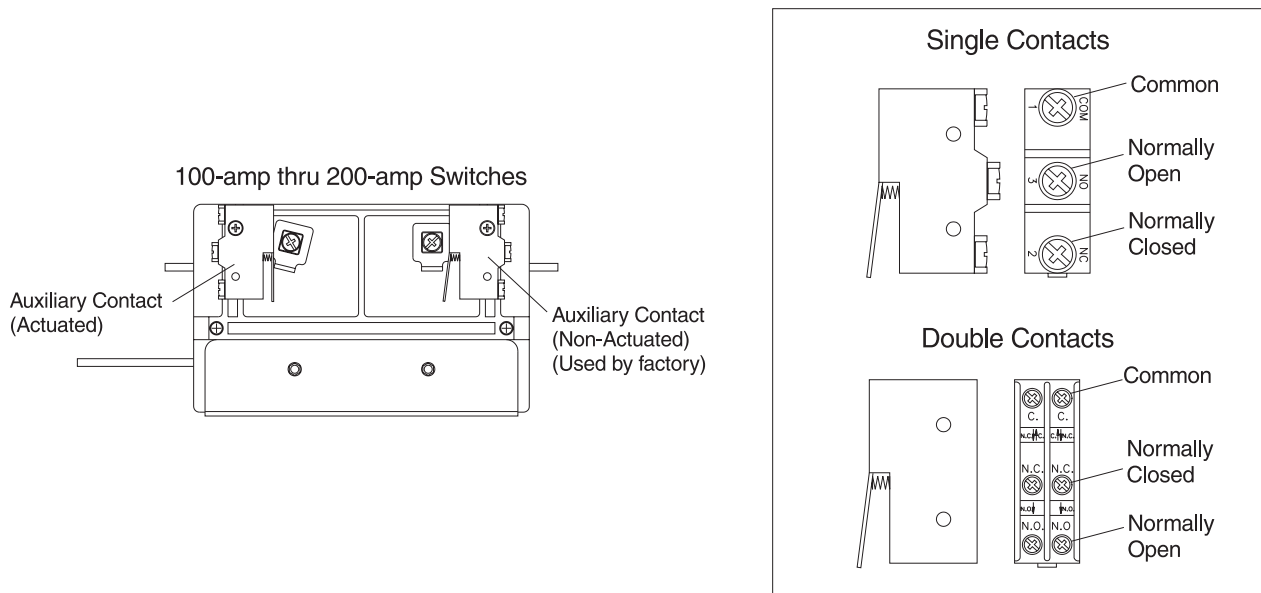

Figure 2.3 — Auxiliary Contact Diagram



3.1 FUNCTIONAL TESTS AND ADJUSTMENTS

Following transfer switch installation and interconnection, inspect the entire installation carefully. A competent, qualified electrician should inspect it. The installation should comply strictly with all applicable codes, standards, and regulations. When absolutely certain the installation is proper and correct, complete a functional test of the system. Perform functional tests in the exact order presented in this manual, or damage to the switch could result.

IMPORTANT: Before proceeding with functional tests, read and make sure to understand all instructions and information in this section. Also read the information and instructions of labels and decals affixed to the switch. Note any options or accessories that might be installed and review their operation.

3.2 MANUAL OPERATION



Do NOT manually transfer under load. Disconnect transfer switch from all power sources by approved means, such as a main circuit breaker(s).

A manual HANDLE is shipped with the transfer switch and attached to the inside of the door. Manual operation must be checked BEFORE the transfer switch is operated electrically. To check manual operation, proceed as follows:

1. In the transfer switch enclosure, set the Maintenance Disconnect switch to MANUAL. This prevents the generator from starting automatically as soon as the UTILITY power source is turned OFF.
2. If so equipped, turn the generator's auto-off-Manual switch to OFF.
3. Turn OFF both NORMAL and STANDBY service disconnect circuit breakers.
4. Note position of transfer mechanism main contacts by observing display windows in "A" and "B" in Figure 3.1 as follows:
 - Window "A" ON, Window "B" OFF - LOAD terminals (T1, T2, T3) are connected to NORMAL terminals (N1, N2, N3).
 - Window "A" OFF, Window "B" ON - LOAD terminals (T1, T2, T3) are connected to STANDBY terminals (E1, E2, E3).

Figure 3.1 — Actuating Transfer Switch



DANGER: Do NOT manually transfer under load. Disconnect transfer switch from all power sources by approved means, such as a main circuit breaker(s).

Detail of instructions printed on transfer switch

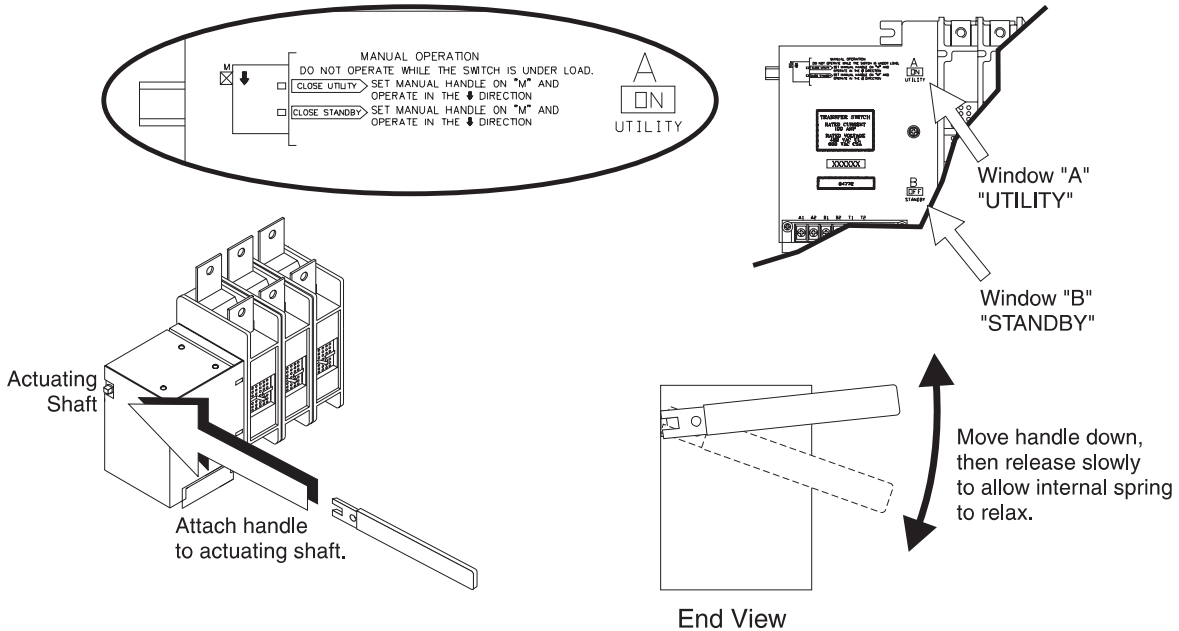

NOTE: Return handle to storage position in enclosure when finished with manual transfer

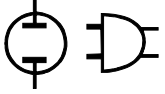

CAUTION



Do not use excessive force when operating the transfer switch manually or damage to the manual handle could result.

◆ 3.2.1 CLOSE TO NORMAL SOURCE SIDE

Before proceeding, verify the position of the switch by observing window “A” in Figure 3.1 on page 8. If window “A” reads “ON”, proceed with Step 1, and if it reads “OFF”, proceed with Step 2.

Step 1: With the handle attached to the actuating shaft, move handle in the direction of the arrow on the switch cover until it stops — DO NOT FORCE. Release handle slowly to release the spring in the switch box. “OFF” now appears in Window “A” and “ON” appears in Window “B”. (Proceed with Step 2).

Step 2: With the handle attached to the actuating shaft, move handle in the direction of the arrow on the switch cover until it stops — DO NOT FORCE. Release handle slowly to release the spring in the switch box. “ON” now appears in Window “A” and “OFF” appears in Window “B”. (Proceed with B: Close to STANDBY Source Side).

◆ 3.2.2 CLOSE TO STANDBY SOURCE SIDE

Before proceeding, ensure that the previous 3.2.1, “Step 2” Close to NORMAL Source Side is completed. See Figure 3.1. This will ensure that Window “B” on the switch reads “OFF”. With the handle attached to the actuating shaft, move the handle in the direction of the arrow on the switch cover until it stops - DO NOT FORCE. Release handle slowly to release the spring in the switch box. “OFF” now appears in Window “A” and “ON” appears in Window “B”.

◆ 3.2.3 RETURN TO NORMAL SOURCE SIDE

Manually actuate switch to return Window “A” to the “ON” position.

3.3 VOLTAGE CHECKS



DANGER



Disconnect all loads from the transfer switch until all voltage checks and phase rotation checks have been completed to prevent possible injury to personnel and, or damage to equipment.



For safety, set the maintenance disconnect switch (inside transfer switch enclosure) to its MANUAL position before proceeding with voltage checks.



Before proceeding, check the transfer switch data PLATE for switch rated voltage. Make sure the data plate voltage is compatible with NORMAL and STANDBY power source voltages.



Proceed with caution. Do not touch electrically hot terminals, wires, etc. During the voltage checks, the transfer switch is electrically energized.

Perform voltage checks as follows:

1. Inside the transfer switch enclosure, set the Maintenance Disconnect switch to MANUAL.
2. If generator is so equipped, set the ATUO-OFF-MANUAL switch to OFF.
3. On the switch enclosure door, set SYSTEM TEST switch to AUTOMATIC MODE position.
4. On the ATS mechanism, check that the word “ON” is visible in Window “A”, the word “OFF” in Window “B”. See MANUAL OPERATION for location of “A” and “B” windows.

IMPORTANT: DO NOT PROCEED UNTIL STEPS 1, 2, 3, AND 4 HAVE BEEN COMPLETED.



CAUTION



Before proceeding to voltage checks, manually connect the load to NORMAL power supply. window “A” must indicate ON, Window “B” must indicate OFF before proceeding.

5. Turn ON the NORMAL (UTILITY) power supply to the transfer switch, with whatever means provided (such as the main line circuit breaker).



DANGER



The transfer switch is now electrically hot. Proceed with caution.

6. With UTILITY voltage available to the transfer switch, check that the UTILITY SOURCE AVAILABLE and SWITCH - POSITION UTILITY LED on the enclosure door is ON. If either of these two LED's are OFF, turn off the utility power supply to the transfer switch by whatever means provided (such as the main line circuit breaker), then proceed back to Step 1 of “VOLTAGE CHECKS”.
7. Inside the transfer switch, next to the utility circuit breaker, locate the Utility Voltage/Frequency Sensing Module. The four LED's should be ON.
8. With an accurate AC voltmeter, check the phase-to-phase (line-to-line) and phase-to-neutral (line-to-neutral) voltages present at transfer mechanism terminals N1, N2, and N3 (if so equipped), and neutral. SUPPLIED VOLTAGES MUST BE FULLY COMPATIBLE WITH TRANSFER SWITCH RATED VOLTAGE.

⚠ DANGER ⚠

⚠ Ensure that the phase rotation of NORMAL (UTILITY) power lines and transfer switch load power lines are compatible.

9. Refer to the standby generator instruction manual. Make sure the generator engine has been properly serviced and prepared for use, as outlined in that manual. Then start the generator engine manually. Let the engine stabilize and warm up for a few minutes.
10. Turn ON the STANDBY (GENERATOR) power supply to the transfer switch by whatever means provided (such as the main line circuit breaker).
11. With the generator running, check that the GENERATOR SOURCE AVAILABLE LED on the enclosure door is ON.
12. Inside the transfer switch, next to the generator circuit breaker, locate the Generator Voltage/Frequency sensing module. The four LED's should be on.
13. With an accurate AC voltmeter, check phase-to-phase (line-to-line) and phase-to neutral (line-to neutral) voltages present at transfer mechanism terminals E1, E2 and E3 (if so equipped). Also check AC frequency at those terminals. If frequency is incorrect, the engine governor may require adjustment. Generator AC output voltage and frequency must be compatible with transfer switch rated voltage and frequency.

⚠ DANGER ⚠

⚠ Ensure that the phase rotation of STANDBY (GENERATOR) power lines and transfer switch NORMAL (UTILITY) and load power lines are compatible.

14. If supplied voltage or frequency is incorrect, refer to standby generator Owner's Manual. If AC frequency is incorrect, adjust engine governed speed. If voltage is incorrect, adjust generator's voltage regulator or correct the problem.
15. When supplied voltage and frequency is correct, shut down the engine manually.

⚠ DANGER ⚠

⚠ Supplied voltages from both NORMAL (UTILITY) and STANDBY (GENERATOR) power sources must be compatible with transfer switch rated voltage before proceeding.

16. Connect the transfer switch load to the transfer switch when "voltage checks" section has been completed. Connect the load to the transfer switch by whatever means provided [such as branch circuit, circuit breaker(s)], then proceed with the "ELECTRICAL OPERATION" section.

3.4 ELECTRICAL OPERATION

Test transfer system electrical operation as follows:

1. On the Utility Voltage/Frequency Sensing Module, check that all of the LED's are ON.
2. On the enclosure door, check that the door mounted CLOSED TO UTILITY and the UTILITY SOURCE AVAILABLE LED's are ON.
3. Refer to the appropriate owner's manual. Be sure the standby generator is prepared for automatic operation.
4. In the switch enclosure, set the Maintenance Disconnect switch to AUTOMATIC.
5. Set the Mode Switch to its NORMAL TEST MODE position. Generator startup and transfer to the STANDBY power source should occur with normal time delays. Refer to the SEQUENCE OF OPERATION, Section 3.12.

NOTE:

All systems are equipped with the Inphase Monitor Control board, and advisory LED's on the circuit board will light up to indicate operation of the various solid state timers that control automatic operation. By observing these LED's, the operator can check the automatic operating sequences and times. See SENSOR AND TIMER ADJUSTMENTS, Section 3.15. For a detailed description of the automatic operating sequences, see SEQUENCE OF OPERATION, Section 3.13.

6. When the test is complete, return the System Test Switch to its AUTOMATIC MODE position. Retransfer back to the NORMAL (UTILITY) power source should occur. The generator should shut down according to circuit board timers.

3.5 MAIN CONTACTS AT NORMAL (UTILITY)

The illustration shows the LOAD terminals connected to the NORMAL (UTILITY) terminals. window "A" will display the word "ON"; Window "B" the word "OFF" (Figure 3.2).

Figure 3.2 — Main Contact at Normal (Utility)

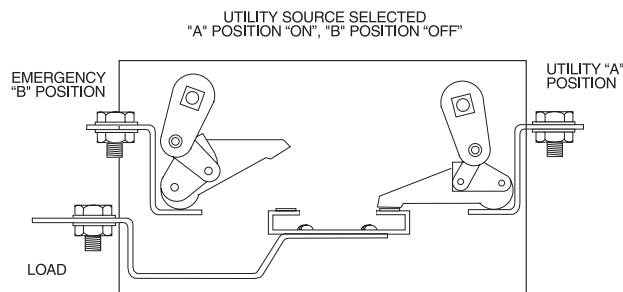

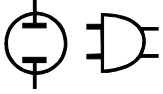

3.6 MAIN CONTACTS AT NEUTRAL

LOAD terminals are disconnected from both power supply terminals. The word “OFF” will be displayed in both Windows “A” and “B” (Figure 3.3). This occurs when the solenoid coil is kept energized.

Figure 3.3 — Main Contacts at Neutral

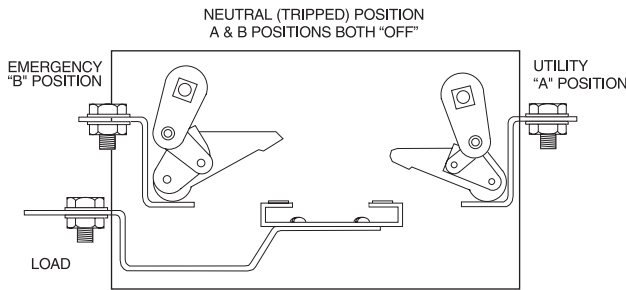

3.7 MAIN CONTACTS AT STANDBY (EMERGENCY)

LOAD terminals are connected to the standby (EMERGENCY) power supply. Window “B” will display the word “ON”; Window “A” the word “OFF” (Figure 3.4 on page 10).

Figure 3.4 — Main Contacts at Standby (Emergency)

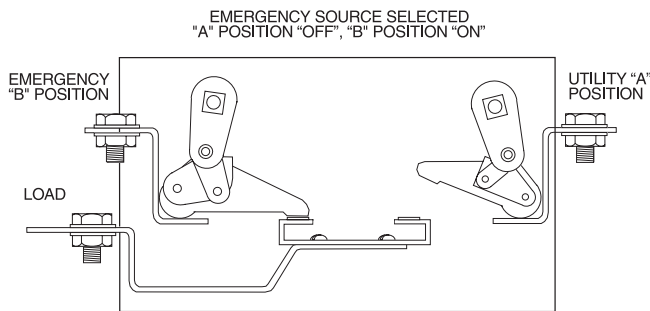

3.8 SWITCHES AND ADVISORY LAMPS

This section will familiarize personnel with switches and advisory lights on the transfer switch enclosure door, as well as with the Safety Disconnect Switch inside the switch enclosure.

Circuit board inside the switch door may also mount several switches. Operation of these switches is covered in the section entitled SENSOR AND TIMER ADJUSTMENTS.

3.9 SYSTEM TEST SWITCH

This switch permits operator selection of AUTOMATIC, NORMAL TEST or FAST TEST mode (Figure 3.5).

◆ 3.9.1 AUTOMATIC MODE

Use this switch position for all normal automatic operations. With AUTOMATIC MODE selected, any NORMAL source voltage that dropped below a pre-set value, results in the automatic sequence of events listed in the chart in Section 3.13.

◆ 3.9.2 NORMAL TEST MODE

Permits the operator to test automatic operations, just as though an actual drop in NORMAL source voltage had occurred. See the chart in Section 3.13. During the test, observe the LED’s on the transfer switch, and in-phase circuit board to monitor automatic operating sequences.

◆ 3.9.3 FAST TEST MODE

Permits the operator to test system operation with all circuit board timers accelerated to less than five seconds. Switch is spring-loaded back to AUTOMATIC MODE, so continuously hold the switch to the FAST TEST MODE. Following the generator startup, loads are transferred to the STANDBY (GENERATOR) power source as soon as GENERATOR source voltage and frequency have reached the settings of STANDBY VOLTAGE/FREQUENCY SENSING MODULE.

Figure 3.5 — System Test Switch and ATS Status

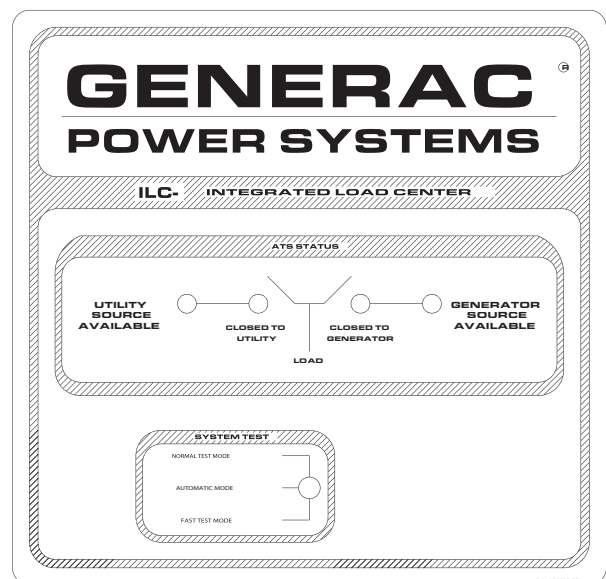

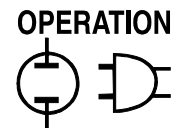

3.10 SOURCE AVAILABLE LED

◆ 3.10.1 UTILITY

This LED will go ON when the UTILITY (NORMAL) supply voltage is available to the transfer switch.

◆ 3.10.2 GENERATOR

This LED will go ON when the GENERATOR (STANDBY) supply voltage is available to the transfer switch.

3.11 SWITCH POSITION LED

◆ 3.11.1 CLOSED TO GENERATOR

This LED will go ON when main current-carrying contacts have actuated to their STANDBY (GENERATOR) position and that power source is available to the transfer switch.

◆ 3.11.2 CLOSED TO UTILITY

This LED will go ON when main contacts have actuated to NORMAL (UTILITY) position and that power supply is available to the transfer switch.

The switch is equipped with the Inphase Monitor Control circuit board. The sensors and timers are adjustable (see SENSOR AND TIMER ADJUSTMENTS).

3.12 SEQUENCE OF OPERATION

When acceptable UTILITY source voltage is available, observe the following:

- Utility/Frequency Sensing Module LED's are ON.
- CLOSED TO UTILITY LED is ON.
- Transformer reduced LOAD (T) terminal voltage is delivered to the 7-day exerciser board to operate the 7-day exercise timer.

Monitor automatic timers and sensors on the Inphase Monitor Control circuit board, by observing the LED's next to the sensor/timer adjustments.

◆ 3.12.1 SEQUENCE 1 - VOLTAGE DROPOUT

- UTILITY source voltage drops below 92% of the nominal voltage. The voltage LED is OFF.
- Voltage dropout below this sensor's setting triggers Sequence 2.

◆ 3.12.2 SEQUENCE 2 - LINE INTERRUPT DELAY

- UTILITY voltage dropout below 92% of nominal voltage sensor turns on a line Interrupt Delay Timer.
- Line Interrupt Delay is fixed at three seconds.
- If voltage dropout lasts longer than Line Interrupt Delay setting, circuit board action closes the automatic start circuit (Wires 178 and 183). When that circuit closes, engine cranks and starts as controlled by a circuit board in the generator's control panel.
- Once the standby generator starts and produces voltage, the inphase monitor circuit board is turned ON (go to Sequence 3).

◆ 3.12.3 SEQUENCE 3 - ENGINE MINIMUM RUN AND WARMUP TIMERS

- This timer establishes the minimum length of time for the generator to run before it can be shut down. The timer prevents shutdown of a cold engine.
- The timer is adjustable from five to 30 minutes; factory setting is about 20 minutes.
- An engine warmup timer is also turned ON. This timer permits engine to stabilize and warm up before loads are transferred to STANDBY. This timer is adjustable from five seconds to three minutes. Factory setting is about one minute.

◆ 3.12.4 SEQUENCE 4 - STANDBY VOLTAGE AND FREQUENCY SENSORS

- If generator AC output voltage and frequency is above the setting of these sensors, loads transfer to the GENERATOR power source.
- The GENERATOR voltage and frequency are monitored in two places.
 1. On the Inphase Monitor control PCB. The Inphase Monitor PCB senses under voltage (adjustable between 85 and 95%) and under frequency (adjustable between 80 and 90%).
 2. The Voltage/Frequency Sensing Modules will monitor under and over voltage and frequency. This module is set to accept Generator Voltage between 92% and 108%. Generator Frequency between 97% and 103%.

These modules are connected in series and must both be satisfied before transfer is allowed.

NOTE:

Bypass the engine warmup timers by setting the Engine Warmup Timer Bypass switch to ON. Loads are transferred to STANDBY as soon as generator AC voltage and frequency have reached the settings of the Voltage and Frequency sensors without having to wait for the engine to warm up.

OPERATION

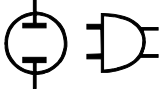

Section 3 – Operation

Generac ILC Type Transfer Switch

◆ 3.12.5 SEQUENCE 5 - VOLTAGE PICKUP

- If the Utility voltage is restored above 92% and is less than 108% of nominal voltage, and the Utility frequency is between 57 and 63 Hz, Sequence 5 will begin.

◆ 3.12.6 SEQUENCE 6 - RETURN TO UTILITY TIMER

- This timer prevents re-transfer that a Utility Source voltage surge or transient might cause.
- Adjust timer between one to 30 minutes. Factory setting is about five minutes.
- If UTILITY voltage remains above the setting of the Voltage/Frequency Sensing Module for the time interval of the Return to Utility Timer setting, loads are re-transferred back to the UTILITY source.

◆ 3.12.7 SEQUENCE 7 - ENGINE COOL DOWN TIMER

- After the switch re-transfers loads back to UTILITY, this timer starts. When the interval has “timed out”, the automatic start circuit (Wires 178 and 183) is opened, and the engine shuts down.
- The timer permits the engine to run at no load for a fixed time, so the engine internal temperature can stabilize before shutting down.
- The timer can be set anywhere between one to 30 minutes. Factory setting is about 10 minutes.

NOTE:

Actual time between re-transfer back to UTILITY and engine shutdown is whichever is longer of the Engine Cool Down timer setting or any time remaining on Engine Minimum run timer.

After the switch automatically re-transferred loads back to the UTILITY power source and generator has shut down, the system is “ready” for Sequence 1 again.

3.13 SENSOR AND TIMER ADJUSTMENTS - SENSING CIRCUIT BOARD

This sensor (Figure 3.6) establishes the acceptable range for the UTILITY power source voltage and frequency range. If the UTILITY voltage and frequency is outside of the preset range listed below, the generator will startup and transfer the load to the GENERATOR power source. The UTILITY voltage and frequency sensor is preset as follows:

- Under voltage 92% - 240 VAC L-L systems = 221 VAC, 208 VAC L-L systems = 191 VAC.
- Over voltage 108% - 240 VAC L-L systems = 259 VAC, 208 VAC L-L systems = 225 VAC.

- Under frequency 95% - 57 Hz.
- Under frequency 105% - 63 Hz.

Figure 3.6 — Utility Power Source Voltage and Frequency Range

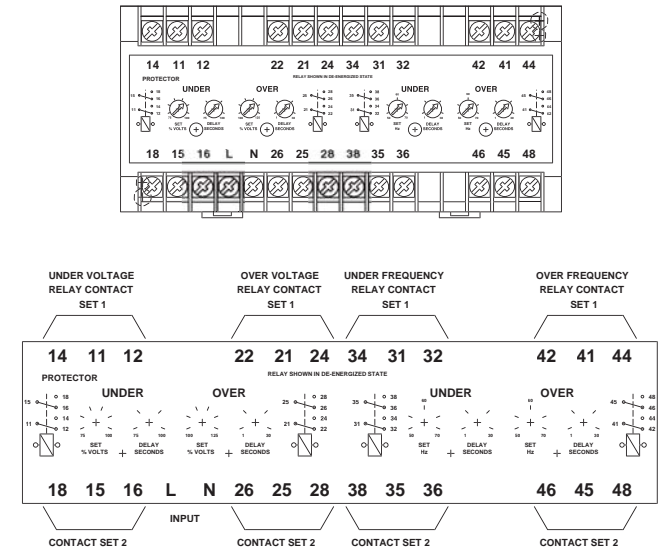

◆ 3.13.1 VOLTAGE AND FREQUENCY PICKUP AND DROPOUT

One setting is used for both pickup and dropout of each individual function.

The differential for each of the setting is as follows:

- Voltage - 1.5%
- Frequency - 0.3 Hz

This is typically referred to as the hysteresis. This is built in to prevent oscillation, should the actual voltage or frequency actually be at the limits of the preset band.

◆ 3.13.2 LINE INTERRUPT DELAY TIMER

This establishes a definite time between when the utility voltage drops below the preset minimum voltage and the time the generator start signal will occur. This is preset to three seconds. On a complete voltage failure, the time delay may be reduced. All other functions (over voltage, over/under frequency) will signal a generator start in two seconds.

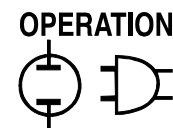

3.14 SEQUENCE OF OPERATION SETTINGS

Units with Inphase Monitor Control Circuit Board

SEQUENCE	ACTION	TIMER/SENSOR	ADJUST RANGE	FACTORY SETTING
—	UTILITY voltage available - no action*	Voltage/Frequency Sensing Module	Preset	
A*	UTILITY voltage drops out Voltage between 92% - 108% Frequency between 57 - 63 Hz	Voltage/Frequency Sensing Module	Preset	
B	Line Interrupt Delay Timer Starts	Line Interrupt Delay Timer	Preset	3 seconds
C	Line Interrupt Delay Timer Stops	Line Interrupt Delay Timer	Preset	3 seconds
—	Engine cranks and starts			
D	Engine Minimum Run Timer starts	Engine Minimum Run Timer	5 to 30 minutes	20 minutes
E**	Engine Warmup Timer Starts	Engine Warmup Timer	5 sec. - 3 min.	1 minute
F	Generator Source Available LED ON			
G**	Engine Warmup Timer stops	Engine Warmup Timer	5 sec. - 3 min.	1 minute
H	Is STANDBY voltage good?	Generator Voltage/Frequency	Preset	92 - 108%
J	Is STANDBY frequency good?	Generator Voltage/Frequency	Preset	57 - 63 Hz
K	Time Delay at NEUTRAL (if selected)	Time Delay Neutral Timer	0.1 - 10 seconds	5 seconds
L	Inphase Transfer	Inphase Transfer Select	None	
—	Transfer to STANDBY			
M	CLOSED TO GENERATOR LED ON			
—	GENERATOR source powers LOAD			
N	UTILITY voltage restored	Voltage/Frequency Sensing Module	Preset	92 - 108%
O	Return to UTILITY Timer ON	Return to Utility Timer	1 - 30 minutes	5 minutes
P	Timed Delay at NEUTRAL (if selected)	Time Delay Neutral Timer	0.1 - 10 seconds	5 seconds
R	Inphase Transfer (if selected)	Inphase Transfer Select	none	0.1 - 30 seconds
S	Signal Before Transfer LED lights	Signal Before Transfer Timer	1 - 30 seconds	10 seconds
—	Re-transfer to UTILITY source			
T***	Engine Cooldown Timer starts	Engine Cooldown Timer	1 - 30 minutes	10 minutes
U***	Engine Cooldown Timer stops	Engine Cooldown Timer	1 - 30 minutes	10 minutes
—	Engine shuts down			
—	UTILITY voltage available - no action			

* Voltage between 92% - 108%. Frequency between 57 - 63 Hz

** Engine Warmup Timer can be bypassed. See SENSOR AND TIMER ADJUSTMENTS

*** Following re-transfer to UTILITY source, engine shutdown will not occur until both Engine Minimum run and Engine Cooldown timers have timed out.

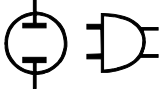

3.15 ADJUSTMENTS ON INPHASE MONITOR CONTROL CIRCUIT BOARD

The Inphase Monitor Control board is operational only when the generator set is running and producing voltage. Transfer will occur when UTILITY and GENERATOR voltage and phase are comparatively equal with a maximum difference of 20° between the power sources. To assure precision matching control, minimum voltage and frequency ranges are specified by the operator. In addition, each inphase control is programmed with the use of an onboard DIP switch (SW1) to match the actuation time of the corresponding switch. Inphase transfer is used only between two live power sources and NOT during a UTILITY source failure. The Inphase Monitor Control board (Figure 3.7) is designed to transfer loads under the following conditions:

- When generator set frequency is between 58-62 Hertz (48-52 Hertz for 50 Hertz systems).
- When generator set and utility power source frequencies are within two Hertz.
- When the generator set and utility source voltage are within 85-100 percent of normal voltage.
- When both power sources are able to come into phase within 10 seconds.
- When less than 10 seconds has elapsed since the engine warmup timer has expired.

If any one of the preceding conditions are not met within 30 seconds, the system will automatically revert to Time Delay Neutral (if selected). If Time Delay Neutral is not selected, the switch will transfer immediately after failing to do an inphase transfer within the 30 second window.

◆ 3.15.1 ENGINE WARMUP TIMER

Permits the engine to warm up before transferring LOAD from NORMAL to STANDBY power. Reset timer to any time interval between five seconds and three minutes. Factory setting is about one minute.

◆ 3.15.2 ENGINE MINIMUM RUN TIMER

Establishes the minimum length of time the generator must run before it can be shut down automatically. Timer prevents a cold engine from being shut down. Timer can be reset to any interval between five and 30 minutes. Factory setting is about 20 minutes.

◆ 3.15.3 RETURN TO UTILITY TIMER

Establishes time interval between restoration of NORMAL source voltage above the setting of the Voltage Pickup Sensor and re-transfer back to that source. This time interval is necessary, to prevent re-transfer that otherwise might occur as a result of transient voltages. Timer can be reset to any interval between one and 30 minutes. Factory setting is about five minutes.

◆ 3.15.4 ENGINE COOL DOWN TIMER

Provides a time delay between automatic re-transfer back to the NORMAL source and engine shutdown. This permits internal engine-generator temperatures to stabilize at “no-load” prior to shutdown. Set timer between one and 30 minutes. Factory setting is about 10 minutes.

NOTE:

The actual time interval between re-transfer back to NORMAL and generator shutdown, is the time remaining on Engine Minimum Run timer or time setting of the Engine Cool Down Timer, whichever is longer.

◆ 3.15.5 STANDBY VOLTAGE SENSOR

After engine starts automatically, the system does not transfer LOAD to STANDBY power source until generator AC output voltage has reached the setting of this sensor. Factory set to about 95% of the nominal rated voltage, but can be reset between 85% and 95% of the unit's rated voltage.

◆ 3.15.6 STANDBY FREQUENCY SENSOR

This adjustment allows the installer or operator to select the minimum required frequency of the standby power source. It is adjustable between 80-90%. Factory setting is 90%.

◆ 3.15.7 SIGNAL BEFORE TRANSFER TIMER

This optional timer controls the amount of time the signal remains active. Timer is adjustable from one to 30 seconds. Factory setting is about 10 seconds.

NOTE:

The “Signal Before Transfer” feature provides a time delay that allows elevators (for example) to continue operating before transfer to another power supply occurs.

◆ **3.15.8 TIME DELAY NEUTRAL**

This timer holds the transfer mechanism’s main contacts in the “Neutral” position for the time selected. “Neutral” is the main contacts position where the LOAD is disconnected from both UTILITY and STANDBY power supplies. Timer is adjustable from 0.1 and 10 seconds. Factory setting is about five seconds.

◆ **3.15.9 CALIBRATION MODE SWITCH**

This switch has three positions, identified as “STDBY”, “OFF” and “UTIL”. The switch allows the installer or operator to calibrate the circuit board to the existing generator set output voltage and to the existing UTILITY power source voltage. The board must be calibrated to both power source voltages in order to initiate transfer and re-transfer at the correct voltages. To calibrate the circuit board to the correct voltage, see “Calibrating the Circuit Board” (Section 3.16).

◆ **3.15.10 INPHASE TRANSFER SELECT SWITCH**

This switch allows the operator or installer to select either “Inphase Transfer” or “Time Delay Neutral” operation. The switch may be positioned as follows:

- Switch at ON: Inphase transfer operation is selected.
- Switch at OFF: Time Delay Neutral is activated (if selected).

◆ **3.15.11 SIGNAL BEFORE TRANSFER SWITCH**

This optional switch allows the operator or installer to select the “Signal Before Transfer” feature or to turn OFF the feature. To activate the feature, set the switch to ON. To turn off the feature, set the switch to OFF.

◆ **3.15.12 ENGINE WARMUP TIMER BYPASS SWITCH**

To bypass Engine Warmup Timer and transfer as soon as generator voltage and frequency have reached the setting of the Standby Voltage and Frequency Sensors, set switch to ON. To place engine Warmup Timer back into the automatic operating system, set the switch to OFF.

◆ **3.15.13 TRANSFER ON EXERCISE SWITCH**

For transferring LOAD to the STANDBY source during the 7-day exercise cycle, set switch to ON. For no transfer during the exercise, set switch to OFF.

Figure 3.7 — Inphase Monitor Control Panel

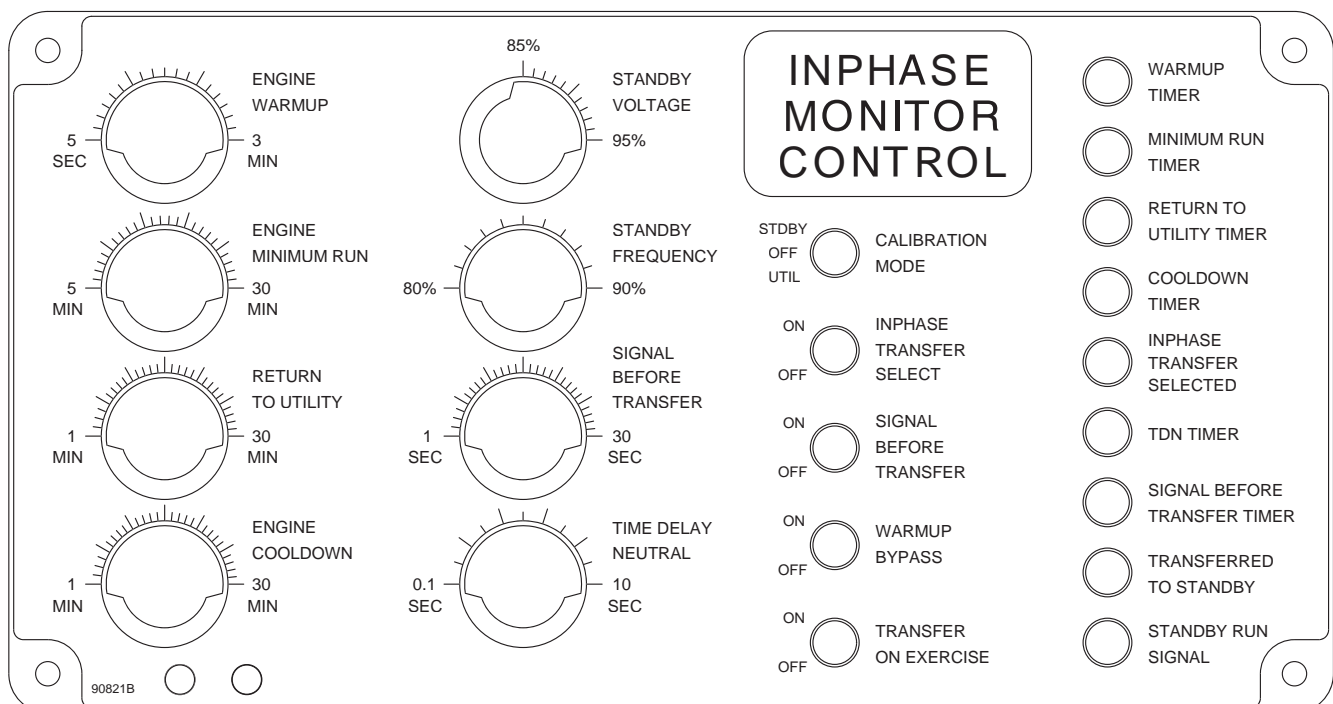

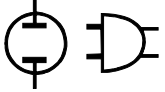

◆ 3.15.14 ADVISORY LAMPS

The advisory lamps on the Inphase Control board consist of nine LED's and include the following:

- The four red timer lamps will turn ON when their respective timers are activated.
- The “Inphase Transfer Selected” lamp goes ON when Inphase Transfer Select switch is set to ON, indicating the system will operate in its “Inphase” mode (and NOT in Time Delay Neutral mode).
- The Time Delay Neutral (TDN) Timer lamp will turn ON when the TDN timer is running.
- The Signal Before Transfer Timer lamp will turn ON for the duration of the Signal Before Transfer Timer, when it is turned ON.
- Transfer to Standby Lamp goes ON when LOAD has been transferred to STANDBY power source.
- Standby run Signal will go ON when the generator is running and the Inphase Monitor Control board is operational and controlling the generator.

3.16 CALIBRATING THE INPHASE MONITOR CONTROL CIRCUIT BOARD

The Inphase Monitor circuit board must be calibrated to existing STANDBY and UTILITY source voltages if the system is to operate properly. To calibrate the circuit board, two adjustment potentiometers (R102 and R107) are provided in the lower left corner of the circuit board (Figure 3.8). The board must be calibrated as follows:

1. Check that UTILITY supply voltage is available to the system.
2. Start the generator, let it stabilize and warm up.
3. Set the Calibration Mode Switch to “STDBY” and observe the four top LED's on the circuit board (Warmup Timer, Minimum Run Timer, Return to Utility Timer and Cool down Timer). These are the RED lamps.
 - If the two upper LED's are illuminated, calibration is set too low.
 - If the two bottom LED's are illuminated, calibration is set too high.
4. On the circuit board, adjust potentiometer R102 until only the two center LED's are illuminated (Minimum Run and Return to Utility timers).
5. Now, set the Calibration Mode switch to “UTIL” and observe the four upper LED's on the circuit board.
6. Adjust potentiometer R107 until only two center LED's are illuminated (Minimum Run and Return to Utility).
7. Set the Calibration Mode Switch to “OFF”. The Inphase Monitor Control board is calibrated.

Figure 3.8 — Inphase Monitor Control Circuit Board

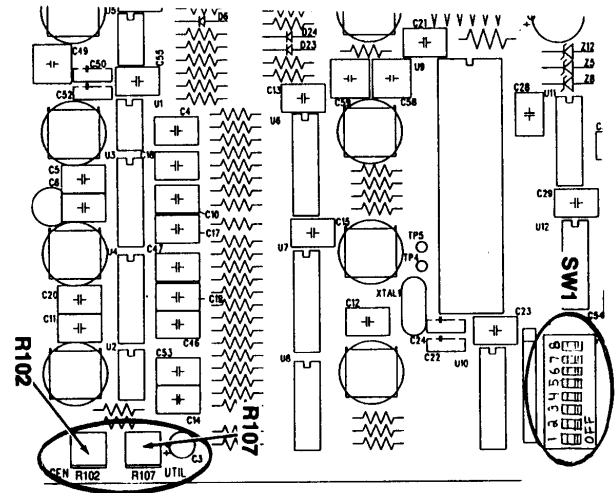

NOTE:

With the Calibration Mode Switch set to “STDBY” or “UTIL”, the four top LED's should turn ON in sequence. That is, the lights should sweep on and off, from one light to the next. Calibration is obtained when the two center lamps of the four (Minimum Run and Return to Utility) are illuminated. This establishes 100% rated voltage.

NOTE:

The Inphase Monitor Control circuit board should be calibrated when the transfer switch has been installed as part of an operating system. Also, replacement circuit boards must be calibrated.

3.17 CIRCUIT BOARD SWITCH SW1

On the Inphase Monitor Control Board, a switch assembly consisting of a bank of eight miniature switches is identified as “SW1” is usually set up at the factory and should require no additional configuring (Figure 3.9).

NOTE:

On boards not installed at the factory, SW1 must be set by the installer. SW1 must be set to match the type of transfer switch in which the board is installed.

The individual switches on SW1 are numbered from “1” (bottom) through “8” (top), as shown in figures 3.14 and 3.15. To make the circuit board compatible to the specific transfer switch assembly, set the switches as indicated in the chart at the bottom of this page. Improper settings may cause transfer outside the 20-degree specification.

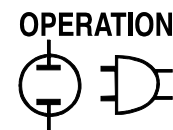

DIP Switch Settings - W-Type Transfer Switches

TRANSFER SWITCH	SWITCH RATED 100/200; 110/220; 115/200; 120/208; 220/380 VOLTS								SWITCH RATED 120/240; 231/400; 240/416 VOLTS								SWITCH RATED 277.480; 346/600 VOLTS							
	1	2	3	4	5	6	7	8	1	2	3	4	5	6	7	8	1	2	3	4	5	6	7	8
100 amps, 2-pole (0D7300)	*	on	off	off	on	off	off	on	*	on	off	off	on	off	off	on	*	on	off	off	on	off	on	off
100 amps, 3-pole (0D7301)	*	on	off	off	on	off	off	off	*	on	off	off	on	off	off	on	*	on	off	off	on	off	on	off
100 amps, 4-pole (0D7302)	*	on	off	off	on	on	off	off	*	on	off	off	on	on	on	off	*	on	off	off	on	on	on	off
150 amps, 2 pole (0C8881)	*	on	off	off	on	on	off	on	*	on	off	on	off	off	off	off	*	on	off	off	on	on	on	off
150 amps, 3-pole (0C8882)	*	on	off	off	on	on	on	off	*	on	off	on	off	off	off	off	*	on	off	on	off	off	off	off
150 amps, 4-pole (0C8883)	*	on	off	on	off	on	on	off	*	on	off	on	on	off	off	off	*	on	off	on	off	on	on	off
200 amps, 2-pole (0C8884)	*	on	off	off	on	on	off	on	*	on	off	on	off	off	off	off	*	on	off	off	on	on	on	off
200 amps, 3-pole (0C8885)	*	on	off	off	on	on	on	off	*	on	off	on	off	off	off	off	*	on	off	on	off	off	off	off
200 amps, 4-pole (0C8886)	*	on	off	on	off	on	on	off	*	on	off	on	on	off	off	off	*	on	off	on	off	on	on	off
300 amps, 2-pole (0D7297)	*	off	on	off	on	on	on	off	*	off	on	on	off	off	off	on	*	off	on	off	on	on	on	on
300 amps, 3-pole (0D7298)	*	off	on	on	off	off	off	off	*	off	on	on	off	off	off	on	*	off	on	on	off	off	off	on
300 amps, 4-pole (0D7299)	*	off	on	on	off	off	off	on	*	off	on	on	off	on	on	on	*	off	on	on	off	on	off	off
400 amps, 2-pole (0D7294)	*	off	on	off	on	on	on	off	*	off	on	on	off	off	off	on	*	off	on	off	on	on	on	on
400 amps, 3-pole (0D7295)	*	off	on	on	off	off	off	off	*	off	on	on	off	off	off	on	*	off	on	on	off	off	off	on
400 amps, 4-pole (0D7296)	*	off	on	on	off	off	off	on	*	off	on	on	off	on	on	on	*	off	on	on	off	on	off	off

* Set Switch 1 to OFF for 60 Hz systems; set Switch to ON for 50 Hz systems

Figure 3.9 — Circuit Board Switch SW1

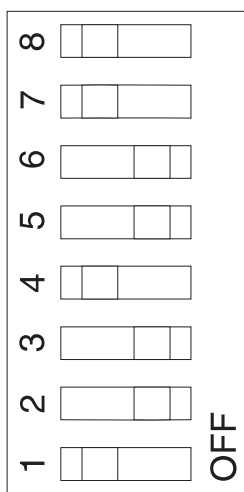

3.18 EXERCISE TIMER DISPLAY
(FIGURE 3.10)

◆ **3.18.1 CURRENT TIME**

The current time is selected with the time push-button and is displayed in 12:00 hour format on four, seven segment LED displays. The colon flashes at a rate of 0.5 seconds on/off to indicate normal operation and display of the current time.

◆ **3.18.2 EXERCISE TIME**

The exercise time is selected with the time push-button, the exercise time for the selected day is displayed in a similar format to current time, except that the colon does not flash but is always ON to indicate that the exercise time is being displayed.

To change the exercise day that is being displayed use the “day” push-button when in this mode.

◆ **3.18.3 PM (TIME)**

A single LED indicates PM (ON) time or AM (OFF).

◆ **3.18.4 DAY OF WEEK**

The day of the week is indicated on the seven individual day LEDs which represent Sunday through Saturday.

◆ **3.18.5 EXERCISE ON (EX)**

A single LED indicates that the relay output is switched ON (exercise period).

◆ **3.18.6 POWER SAVING**

To minimize the power consumption of the unit, the unit will switch to a “dim” display mode if there is no keyboard activity for five minutes. The display brightness is reduced to 50% of normal, but returns to 100% when any key is pressed.

◆ **3.18.7 DEFAULT TIMES**

When the exerciser is first powered up, or if power is removed from the unit and the battery backup has expired, the default times will revert to:

- Current time 9:00 am
- Current day Sunday
- Sun-Sat exercise 9:00 am
- Exercise period 20 minutes

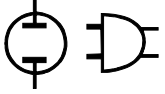
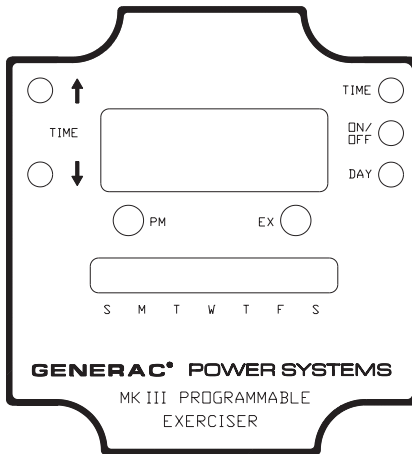
Figure 3.10 — Display

3.19 EXERCISE TIMES

Exercise times may be set individually on a day by day basis. Exercise periods can overlap days. For example, if a time is set for 11:55 pm Sunday for 20 minutes, it turns off at 12:15 am Monday.

The exercise period is globally programmable (common to all days), and is limited from 10-119 minutes.

3.20 PUSHBUTTONS (FIGURE 3.16)

◆ 3.20.1 UP ARROW ↑

The up arrow is used to step the time forward in increments of one minute. This feature has auto-acceleration such that if the button is held on, the step frequency will progressively increase to allow fast searching of a required time. As soon as the button is released, it will revert to normal speed.

◆ 3.20.2 DOWN ARROW ↓

The down arrow is used to step the time backwards in increments of one minute. It also has auto-acceleration.

◆ 3.20.3 TIME (TIME/ALARM TOGGLE)

This toggles the display between normal current time display and exercise time. When in exercise time mode the following happens:

1. The colon stops flashing to indicate exercise time mode.
2. The Sun LED flashes to indicate that it is initially selected. The rate of flashing is either:
 - 50/50% on/off to indicate exercise time is enabled.
 - 90/10% on/off to indicate exercise time is not enabled.

3. All other days that have exercise times enabled to ON are indicated by LED ON, days that are disabled are set to LED OFF.

If the display is inadvertently left in this mode with no keyboard activity for more than five minutes, it will revert back to normal (current time) display.

◆ 3.20.4 ON/OFF (ALARM SELECT TOGGLE)

When in exercise mode, this button will toggle the exercise enable/disable status of the displayed day. The rate of flashing will change as above.

◆ 3.20.5 DAY

The day button is used to step forward through the days in either the current time or exercise time:

- In current time mode, the days will step through seven states indicating Sunday to Saturday.
- In exercise time mode, the days will step through seven states indicating Sunday to Saturday and will then display state eight - all days LEDs flashing on/off together which represents the global exercise time period. In this mode, the exercise period may be changed using the up/down arrows as above but the on time is limited to between 10 and 119 minutes.

3.21 PROGRAMMING EXAMPLES

◆ 3.21.1 EXAMPLE 1 – CHANGE TIME FROM SUNDAY 9:00 AM TO WEDNESDAY 2:00 PM

1. Ensure that current time is displayed by flashing colon. If colon is not flashing, then press and release the “time” push-button once.
2. Press and hold the “Up arrow” push-button until the time steps to almost 2:00 pm - note that the pm LED will now be on.
3. Repeatedly press and release “Up arrow” push-button until exact time is obtained. If you go past 2:00 pm then use the “Down arrow” to step back to the required time.
4. Press the “Day” button to advance the day LED display until the LED next to “W” (Wednesday) is on.

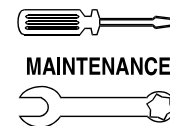

◆ 3.21.2 EXAMPLE 2 – SET EXERCISER ON FOR 14 MINUTES MON-FRI AT 10:00 AM

1. Press and release the “time push-button once to display the exercise time for Sunday, indicated by a static (ON) colon and a flashing “Sun” LED. If the colon is still flashing, then repeat this step.
2. The “Sun” LED should be flashing on/off 90:10, ON but briefly flashes OFF once every two seconds. This means that the exercise time is correctly set to OFF for Sunday. If it is 50:50, this indicates that the exercise time is set to ON, so press and release the “on/off” push-button once to toggle this state to OFF.
3. Press and release the “day” button to advance from Sunday to Monday, indicated by the “Mon” LED flashing.
4. Press and release the “on/off” push-button once to toggle the exercise state from OFF to ON. This will be indicated by the “Mon” LED now flashing on/off 50:50 approx. four times per second as described previously.
5. Repeat steps 3 and 4 for Tues., Wed., Thurs. and Fri. ensuring the correct on/off exercise status for each day.
6. Press and release the “day” button once more and the display will now show “0:20” which is the exercise period in minutes. This is common for all days and this display mode is indicated by all seven “day” lights flashing simultaneously.
7. Use the Up/Down arrows to change the exercise period to 14 minutes.
8. Press and release the “time” push-button once to return the display mode to the current time.

4.1 OPERATE TRANSFER SWITCH

Operate the transfer switch at least once each month. This can be done by performing a NORMAL TEST of the system. Because the System Test switch only simulates failure of the UTILITY power source, service will be interrupted only during the actual transfer of the load.

4.2 CLEAN AND INSPECT TRANSFER SWITCH

Protect the transfer switch against construction grit, metal chips, excessive moisture and other harmful dirt at all times. At least once each year, turn OFF all power supplies to the switch, then brush and vacuum away dust and dirt that has accumulated inside the enclosure. After cleaning, inspect the transfer switch carefully. Look for evidence of arcing, burning, hot spots, charring and other damage. If any of these are found, have the switch assembly checked by an authorized service technician.

4.3 LUBRICATION

Operating parts inside the transfer mechanism have been properly lubricated at the time of assembly. Under normal conditions no additional lubrication should be required. The service technician should lubricate all recommended points whenever major transfer mechanism components are replaced.



Use only specified greases to lubricate contactor parts. DO NOT USE ANY SUBSTITUTES.

Use the following lubricants for the:

1. Main Contacts (Between movable contact and busbars).
 - Dow Corning (Molykote) BR2 Plus; (Mfg. by Dow Corning Co., USA)
 - Liqui-Moly (Mfg. by DAI TO Co., Ltd., Japan)
2. Operating Mechanism (Used on the actuator and other parts of the contactors. Excluding the movable contacts).
 - Mobilgrease 28 (Mfg. by Mobil Oil Co.)
 - Mobiltemp SHC 32 (Mfg. by Mobil Oil Co.)
 - Polo Moly Complex Grease #NLG12 (Mfg. by Polo Lubricants, USA)
 - Rheolube 363 (Mfg. by Nye Lubricants Inc., USA)

4.4 MAIN CURRENT CARRYING CONTACTS

At least once annually, have an Authorized Service Technician check the main current carrying contacts in the transfer mechanism. They will repair or replace major components that have been found defective.

4.5 NINE-VOLT BATTERY

The transfer switch is equipped with an adjustable Inphase Monitor Control circuit board. The battery connects to a separate 7-day exerciser circuit board. Battery power for Exercise Timer operation is only needed during the short time interval when the transfer mechanism main contacts are at NEUTRAL position (LOAD disconnected from both power sources). It is recommended that the nine volt battery be replaced once each year.

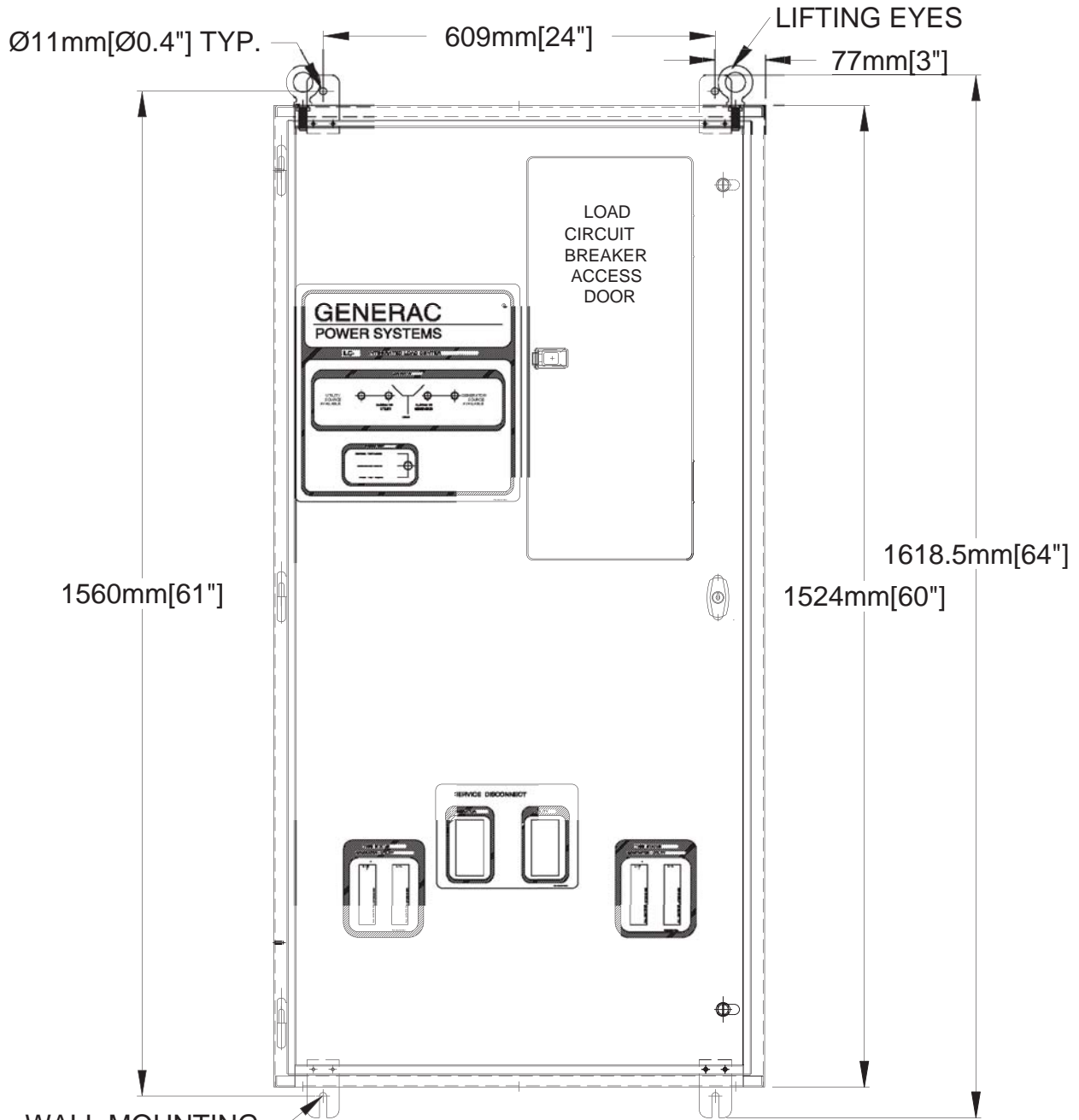
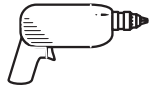

NOT TYPICAL FOR GENERAC MODEL NO'S. 0048760, 0048770

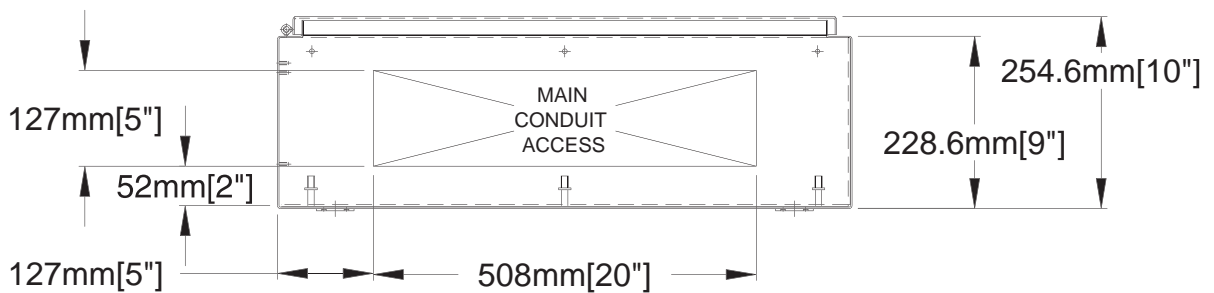

Section 5 – Installation Diagram
Generac ILC Type Transfer Switch
Drawing No. 0E4646

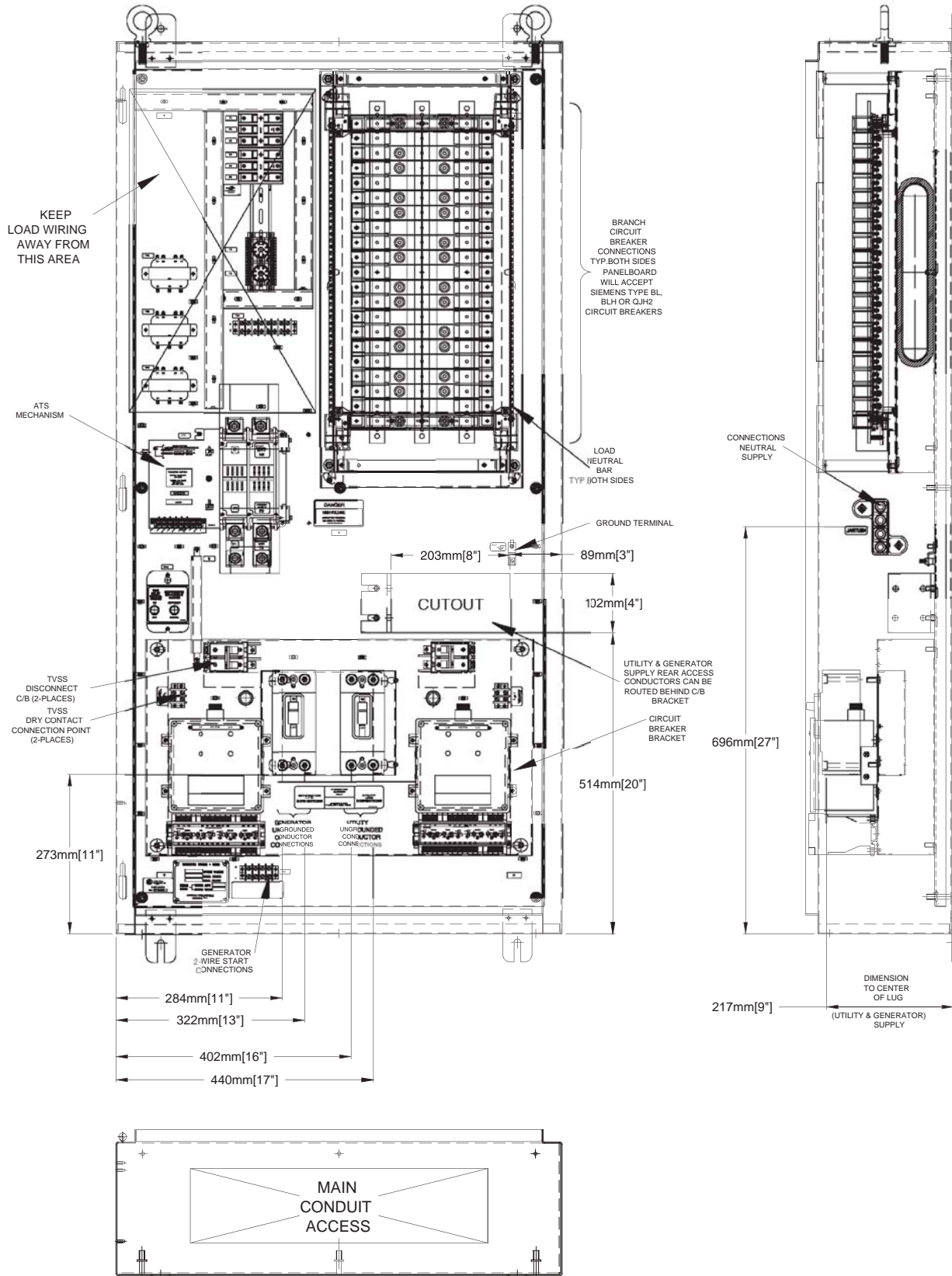

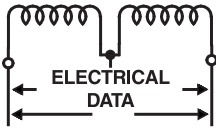

Section 6 – Electrical Data

Generac ILC Type Transfer Switch

Wiring Diagram - Drawing No. 0E4479

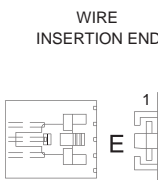
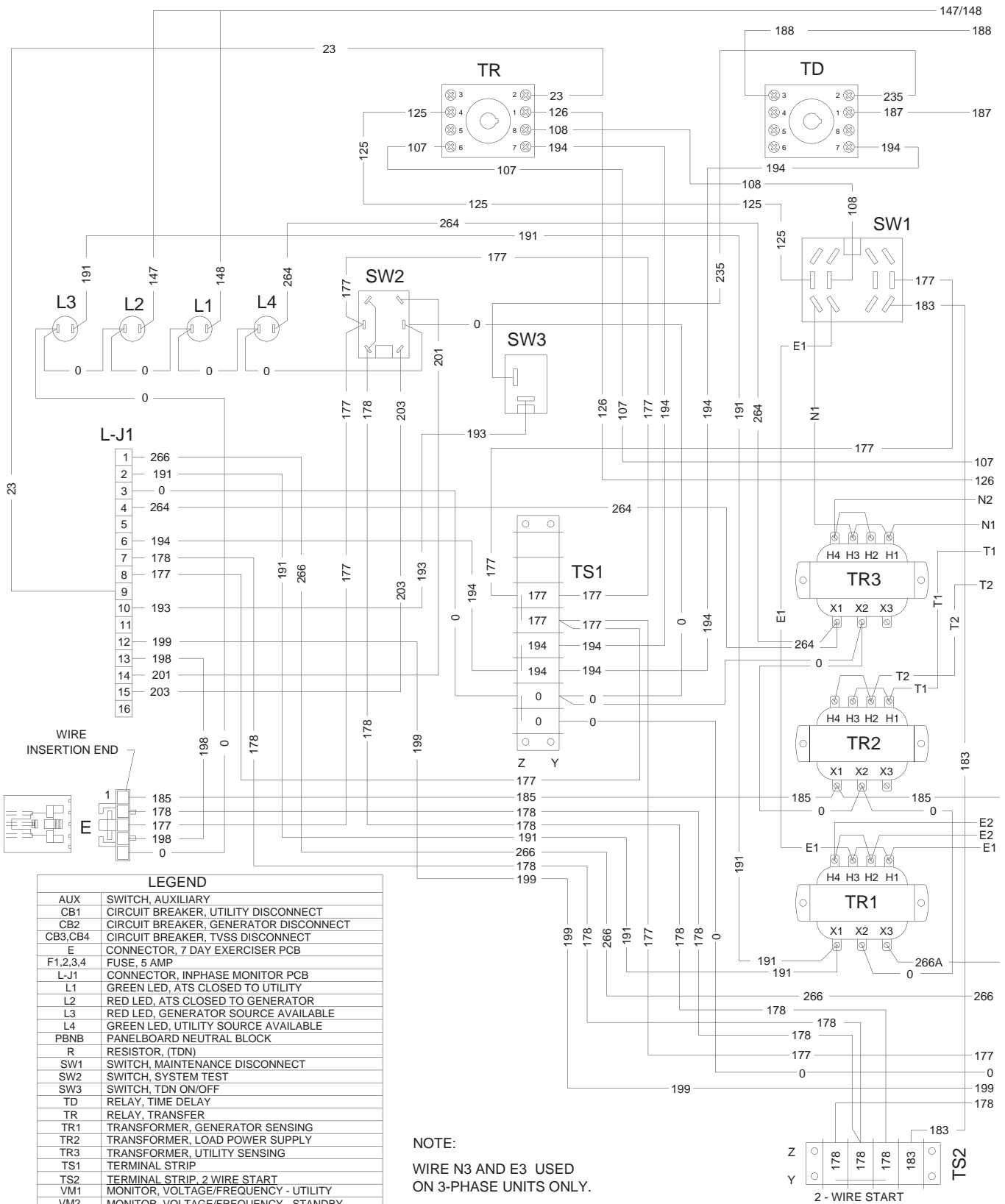

LEGEND

AUX	SWITCH, AUXILIARY
CB1	CIRCUIT BREAKER, UTILITY DISCONNECT
CB2	CIRCUIT BREAKER, GENERATOR DISCONNECT
CB3,CB4	CIRCUIT BREAKER, TVSS DISCONNECT
E	CONNECTOR, 7 DAY EXERCISER PCB
F1,2,3,4	FUSE, 5 AMP
L-J1	CONNECTOR, INPHASE MONITOR PCB
L1	GREEN LED, ATS CLOSED TO UTILITY
L2	RED LED, ATS CLOSED TO GENERATOR
L3	RED LED, GENERATOR SOURCE AVAILABLE
L4	GREEN LED, UTILITY SOURCE AVAILABLE
PBNB	PANELBOARD NEUTRAL BLOCK
R	RESISTOR, (TDN)
SW1	SWITCH, MAINTENANCE DISCONNECT
SW2	SWITCH, SYSTEM TEST
SW3	SWITCH, TDN ON/OFF
TD	RELAY, TIME DELAY
TR	RELAY, TRANSFER
TR1	TRANSFORMER, GENERATOR SENSING
TR2	TRANSFORMER, LOAD POWER SUPPLY
TR3	TRANSFORMER, UTILITY SENSING
TS1	TERMINAL STRIP
TS2	TERMINAL STRIP, 2 WIRE START
VM1	MONITOR, VOLTAGE/FREQUENCY - UTILITY
VM2	MONITOR, VOLTAGE/FREQUENCY - STANDBY

NOTE:
WIRE N3 AND E3 USED
ON 3-PHASE UNITS ONLY.

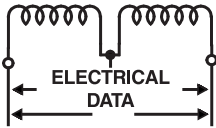

Section 6 – Electrical Data

Generac ILC Type Transfer Switch

Electrical Schematic - Drawing No. 0E4478

NOTE:

WIRE N3 AND E3 USED ON 3-PHASE UNITS ONLY.

ALL RELAY CONTACTS SHOWN WITH ATS IN UTILITY POSITION.

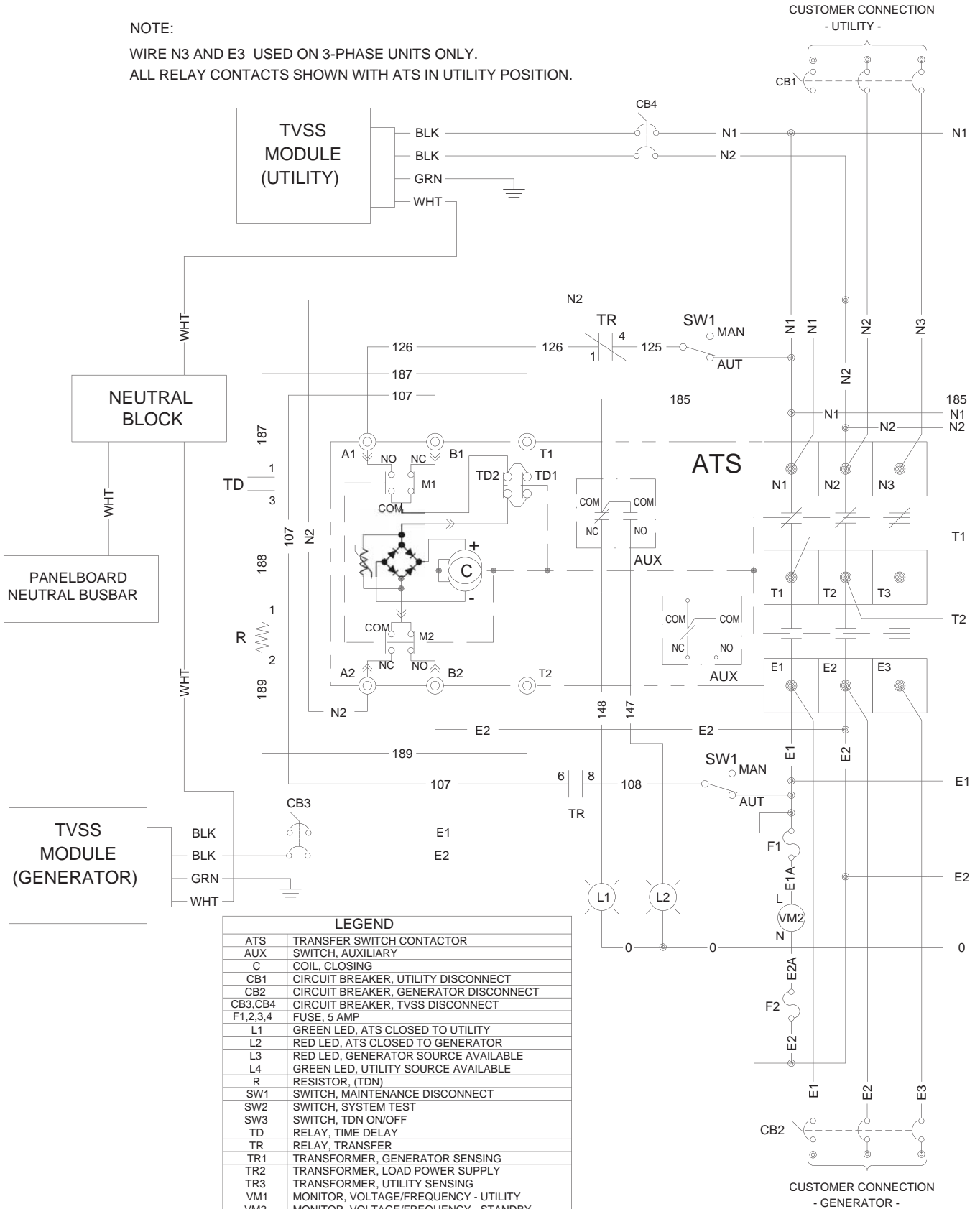

Section 6 – Electrical Data
Generac ILC Type Transfer Switch
Electrical Schematic - Drawing No. 0E4478

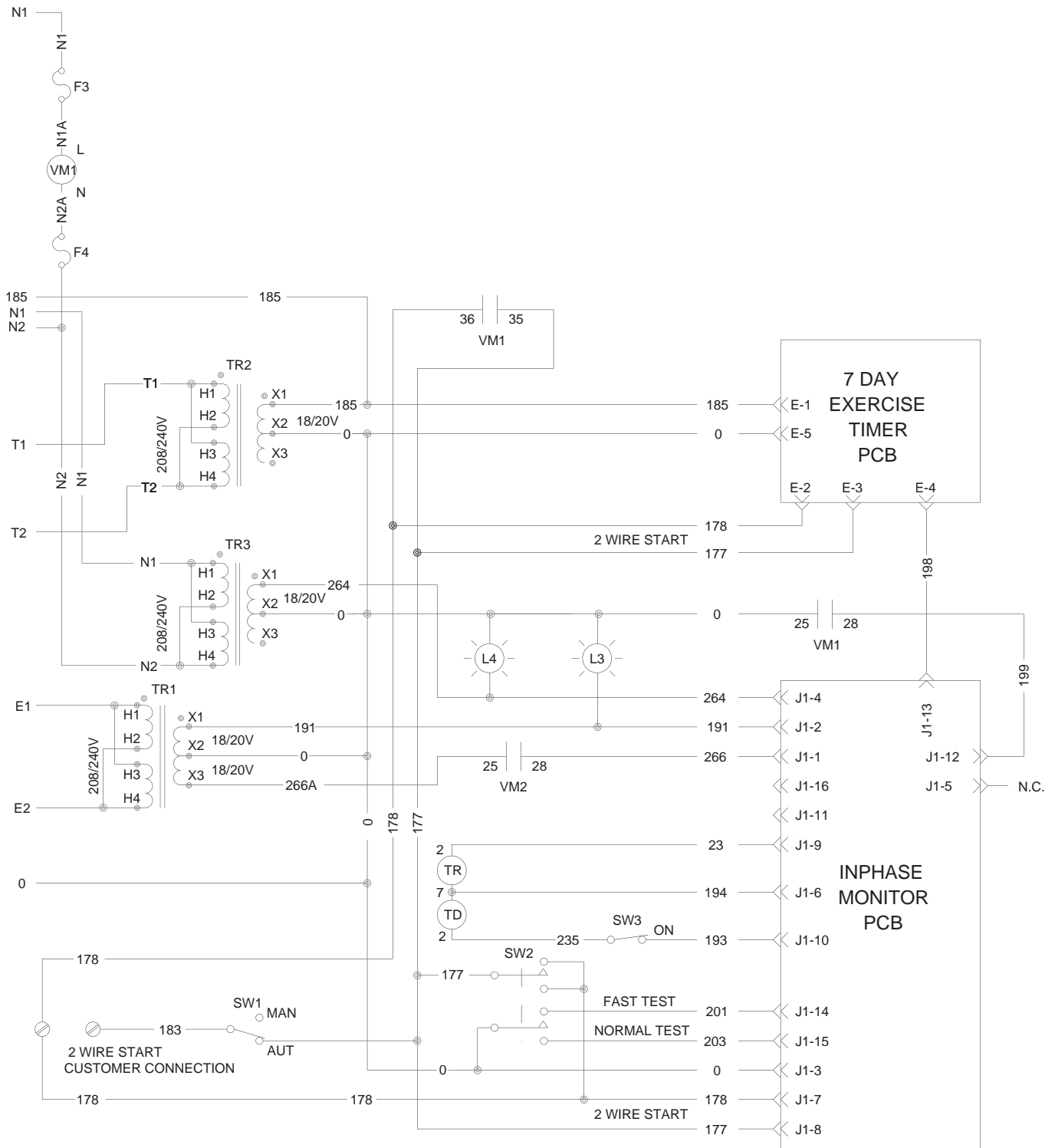
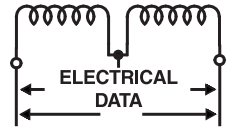



Section 7 – Exploded Views & Parts Lists

Generac ILC Type Transfer Switch

ILC Assembly- Drawing No. 0E4450

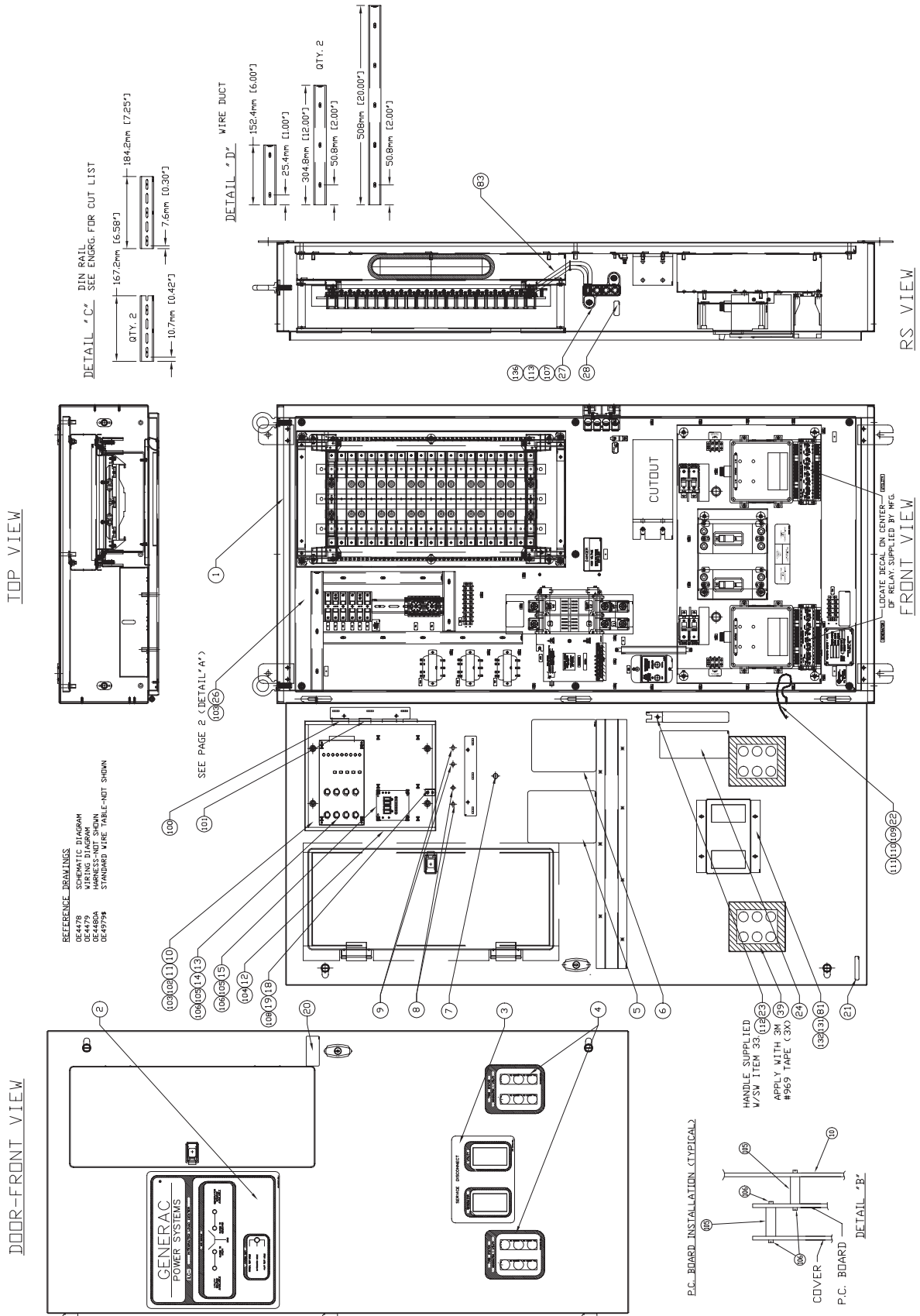

Section 7 – Exploded Views & Parts Lists

Generac ILC Type Transfer Switch

ILC Assembly- Drawing No. 0E4450

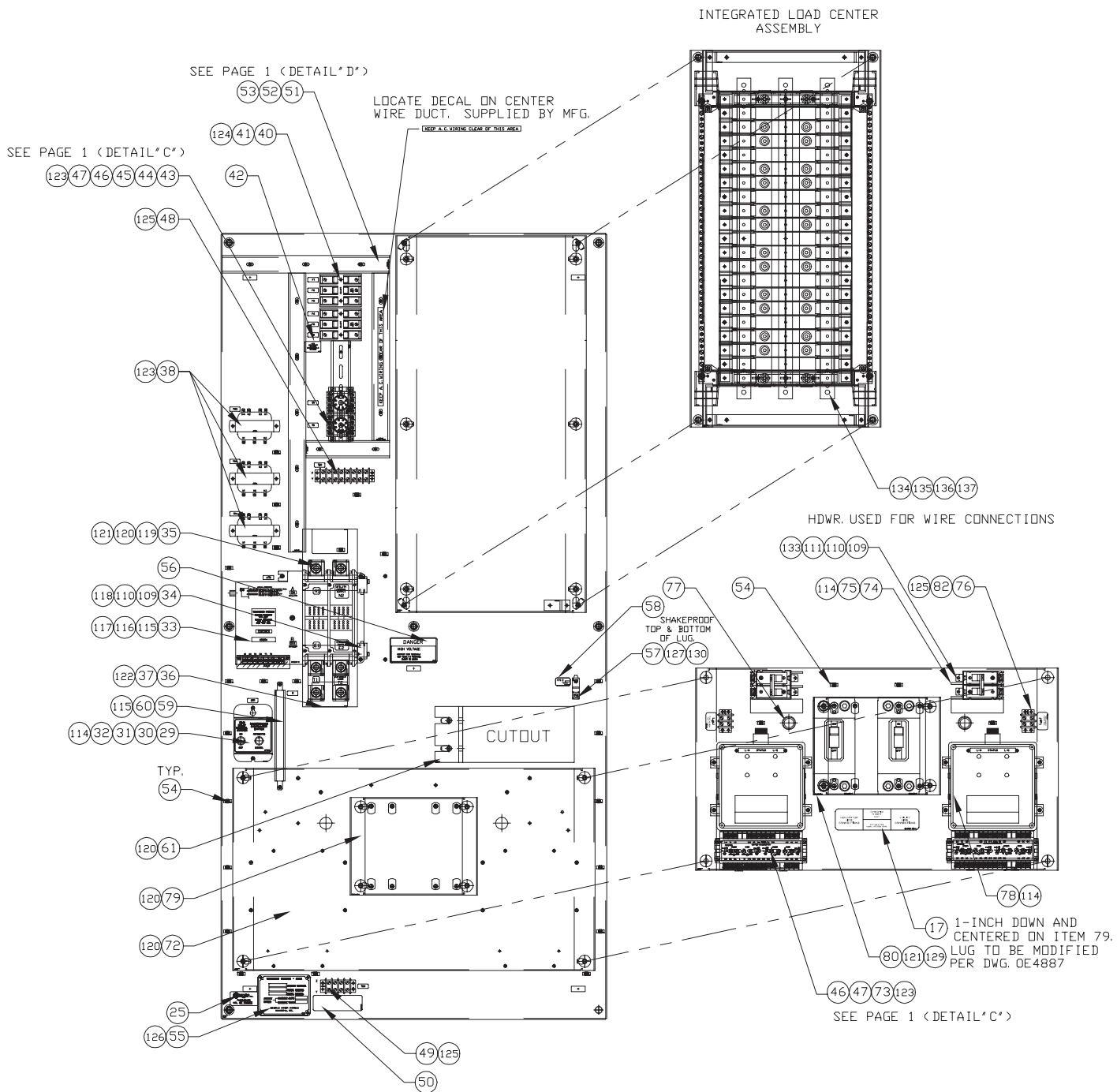

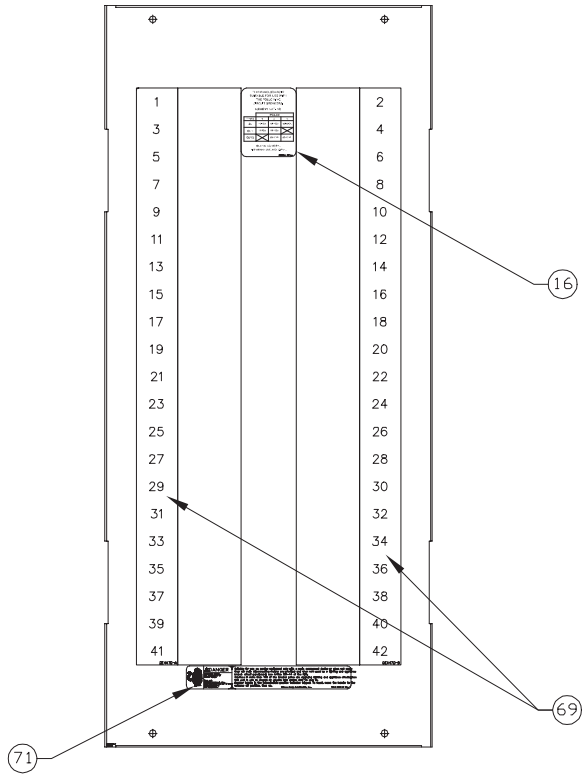

PRE-ASSEMBLY OPERATION

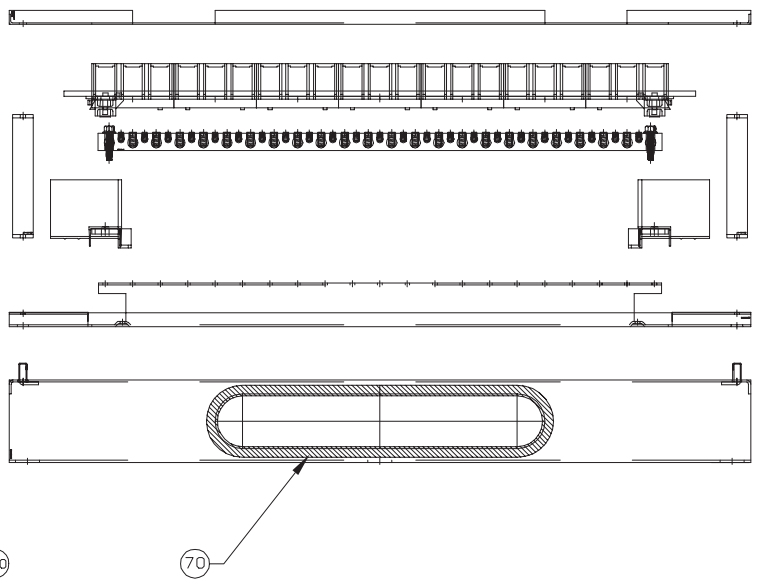
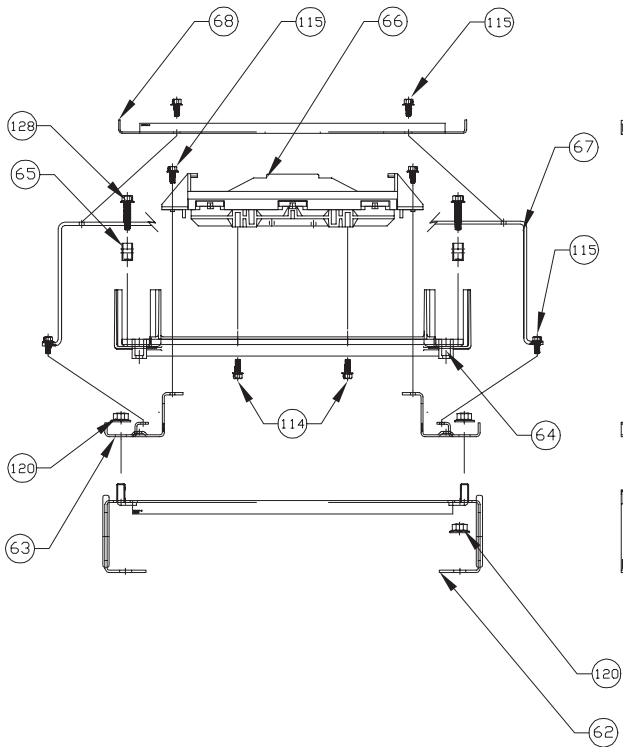
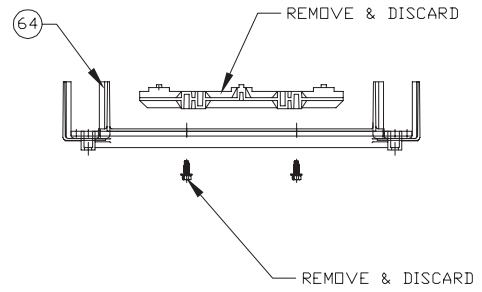

Section 7 – Exploded Views & Parts Lists

Generac ILC Type Transfer Switch

ILC Assembly- Drawing No. 0E4450

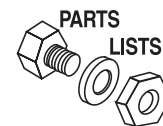

ITEM	PART NO.	QTY.	DESCRIPTION	ITEM	PART NO.	QTY.	DESCRIPTION
1	0E4448	1	ASSEMBLY ENCL. NEMA 1 30 X 60 X 10 1-TVSS	66	0E4466	1	INTEGRATED LOAD CENTER 42 POS.
	0E5100	1	ENCLOSURE NEMA 1 2-TVSS	67	0E4464	2	SUPPORT DEAD FRONT 42 POS.
2	0E4707	1	DECAL POSITION IND./TEST SW.	68	0E4463	1	DEAD FRONT 42 POS. PANELBOARD
3	0E4708	1	DECAL CIRCUIT BREAKER	69	0E4470	1	DECAL LOAD CENTER BRK 1-42
4	0E4709	1	DECAL 1-TVSS	70	056326	1	TRIM VINYL BLACK 1/8 GP 74" (52.8" LG)
	0E4709	2	DECAL 2-TVSS	71	0E4649	1	DECAL (DANGER) ILC
5	063385E	1	DECAL SWITCH INFO-VERIZON	72	0E4461	1	BRACKET CIRCUIT BREAKER W/TVSS
6	073619T	1	DECAL TEST SEQUENCE-VERIZON	73	0E4452	2	RELAY (4) TRIP 240VAC
7	055142	1	SWITCH TOG DPDT 15A MOM W/SEAL	74	0E4147	1	MTG TRACK BQ SIEMENS CB 1-TVSS
8	0C2163B	2	LED RED WITH HOLDER	0E4147	2	MTG TRACK BQ SIEMENS CB 2-TVSS	
9	0C2163A	2	LED GREEN WITH HOLDER	75	0D5535	1	CB 0030A 2P 240V S BQ2 LL 1-TVSS
10	0C1652	1	ENCLOSURE-PCB NEW	0D5535	2	CB 0030A 2P 240V S BQ2 LL 2-TVSS	
11	0C1721	1	DOOR NEW PCB ENC	76	048766	1	BLOCK TERM 20A 2 X 6 X 1100V 1-TVSS
12	0C1720	2	SD GUIDE-NEW PCB ENC	048766	2	BLOCK TERM 20A 2 X 6 X 1100V 2-TVSS	
13	092734	1	ASSEMBLY INPHASE MONITOR	77	023484D	2	BUSHING SNAP SB-875-11
14	094200A	1	ASSEMBLY-INPH COVR PLAT	78	0E4453	1	TVSS (1) MODULE 1PH ATLANTIC SC.
15	0A8637	1	ASSEMBLY MK3 EXERCISER	0E4453	2	TVSS (2) MODULE 1PH ATLANTIC SC.	
16	0E5010	1	DECAL-BREAKERS/BLANKS	79	0E4460	1	BRACKET CIRCUIT BREAKER
17	0E4985	1	DECAL-LINE CONNECTION	80	0E4458	2	CB 200A 240VAC 2P QJ22B200HL
18	063982	1	CLIP BATT-9V TRANSIS	81	0E5143	1	SHIELD CIRCUIT BREAKER
19	063998	1	BATTERY 9V	82	0E4872	1	DECAL TVSS ALARM CONTACTS
20	0E4984	1	DECAL-WARNING/LIVE CIRCUIT	0E4872	2	DECAL TVSS ALARM CONTACTS	
21	077228	1	DECAL-ENCLOSURE NOTE	83	0E5178	1	ASSEMBLY NEUTRAL CABLE
22	0536210193	1	GROUND WIRE-ENCLSR DOOR	100	072252	1	GROMMET 1.37 X .06 X 1.00
23	072164	1	MNL HNDL 6-1600A WN	101	038057	1	GROMMET 7/8 X 1/16 X 3/4
24	0D4545	1	DECAL MANUAL OPERATION	102	022131	4	WASHER FLAT 3/8-M10 ZINC
25	0E4987	1	DECAL-UL PANELBOARD	103	064101	11	NUT LOCK FL 3/8-16
26	0E4449	1	SUBPLATE - 200A 2P/3P	104	036261	4	RIVET POP .125 X .275 AL
27	0E3717A	1	ASSY-NEUT BLK 250-400A W/TAP	105	064525	12	STANDOFF HEX 3/4
28	0A9457	1	DECAL NEUTRAL	106	064526	24	SCREW S-THR PH #6-25 X 3/8 ZNC
29	074509	1	BRACKET SWITCH	107	022097	2	WASHER LOCK M6-1/4
30	074511	1	DECAL TDN MAINTENANCE SW	108	0D7505	2	RIVET POP .094 X .250 BLND AL
31	055868	1	SWITCH TOGGLE 4PDT 15A SPADE	109	038150	7	WASHER FLAT #8 ZINC 1-TVSS
32	028199	1	SWITCH TOGGLE SPST 6A TAB C-H	038150	11	WASHER FLAT #8 ZINC 2-TVSS	
33	0C8884	1	TRANSFER SW-W 200A600V2P	110	022264	5	WASHER LOCK #8-M4 1-TVSS
34	074604	1	AUX CNTCT N-TYPE SPDT	022264	7	WASHER LOCK #8-M4 2-TVSS	
35	0A9949	6	LUG SLDLSS 400-#4 X 1/4-20 CU7AL	111	022471	4	NUT HEX #8-32 STEEL 1-TVSS
36	0C7907H	2	COVER LUG 2P 150/200AMP	022471	6	NUT HEX #8-32 STEEL 2-TVSS	
37	0C8308	2	DECAL TERMINAL SHOCK HAZARD	112	025870	1	NUT WING 1/4-20
38	090975	3	TRANSFORMER 240/40V 25VA	113	022127	2	NUT HEX 1/4-20 STEEL
39	0E4999	1	SHIELD-1-TVSS MODULE	114	0C2267	12	SCREW HHTT M5-0.8 X 12 BP 1-TVSS
	0E4999	2	SHIELD-2-TVSS MODULE	0C2267	18	SCREW HHTT M5-0.8 X 12 BP 2-TVSS	
40	0D2572	2	FUSEBLOCK 30A 600V 3POS W/SQ	115	074908	27	SCREW HHTT M5-0.8 X 10 BP
41	073590A	4	FUSE 5A X BUSS	116	051713	3	WASHER FLAT M5
42	0E4415G	1	DECAL FUSE RATING 5A 600V	117	022152	3	WASHER LOCK #10
43	0C3211G	2	SOCKET RELAY 8 PIN	118	092980	1	SCREW PPHM M4-0.7 X 25
44	0C3211E	2	RELAY PNL 12VDC DPDT 8PIN	119	0C4896	6	SCREW FHM M8-1.25 X 20MM CR
45	0C3211H	4	SPRING RELAY RETAINING	120	067989	26	NUT LOCK FL M8-1.25 YEL CHR
46	0A9992B	6	BRACKET DIN TERM END	121	026902	8	SCREW HHTT #8-32 X 1/4 CZ 1-TVSS
47	0C3996	1	RAIL DIN ALUMINUM BULK	026902	10	SCREW HHTT #8-32 X 1/4 CZ 2-TVSS	
48	057701	1	BLOCK TERM 20A 8 X 6 X 1100V	122	0C8275	4	SCREW PPHM DSEMS M4-7 X 10 ZNC
49	046689	1	BLOCK TERM 20A 4 X 6 X 1100V	123	045764	14	SCREW HHTT M4-0.7 X 8 BP
50	091466	1	DECAL 2 WR TERM STRP	124	0C2265	4	SCREW PHTT M4-0.7 X 12 ZYC
51	091472	1	DUCT WIRING 1X1.5 6 FT	125	0A1661	6	RIVET POP .156 X .675 AL 1-TVSS
52	091472A	1	COVER WIRE DUCT 1 IN	0A1661	8	RIVET POP .156 X .675 AL 2-TVSS	
53	091477	13	RIVET WIRE DUCT MNT	0D6162	4	RIVET POP .156 X .362 AL	
54	063378	38	HOLDER CABLE TIE	127	026850	2	WASHER SHAKEPROOF EXT 1/4 STL
55	063578	1	PLATE DATA - GTS	128	092079	4	SCREW HHTT M6-1.0 X 25 BP
56	054199	1	DECAL DANGER HIGH VOLTAGE	129	036962	4	SCREW PPHM 1/4-20 X 2-3/4
57	0E5020	1	LUG SLDLSS #2-#8	130	052857	1	NUT LOCK FL M6-1.0
58	067210A	1	DECAL GROUND LUG	131	022769	4	WASHER SHAKEPROOF INT #10
59	063971	1	RES 250R 5% 100W	132	028430	4	NUT HEX #10-24 STEEL
60	063324	2	RES MTG BRACKET FOR 100W	133	036917	2	SCREW PPHM #8-32 X 3/8 1-TVSS
61	0E4650	1	SUPPORT GLASTIC	036917	4	SCREW PPHM #8-32 X 3/8 2-TVSS	
62	0E4462	1	BRACKET 42 POS. PANELBOARD	134	030795	2	SCREW HHC 5/16-18 X 1 G5
63	0E4465	2	Z-RAIL 42 POS. PANELBOARD	135	022259	2	NUT HEX 5/16-18 STEEL
64	0E4717	2	BUS SUPPORT ASSY P1-250	136	022473	4	WASHER FLAT 1/4-M6 ZINC
65	0E4469	2	NEUTRAL BAR 45 POS.	137	022129	2	WASHER LOCK M8-5/16



Section 8 – Warranty

Generac ILC Type Transfer Switch

GENERAC POWER SYSTEMS STANDARD TWO-YEAR LIMITED WARRANTY FOR GENERAC TRANSFER SWITCH SYSTEMS

NOTE: ALL UNITS MUST HAVE A START-UP INSPECTION PERFORMED BY AN AUTHORIZED GENERAC DEALER.

For a period of 2 (two) years from the date of sale/start date, Generac Power Systems, Inc. will, at its option, repair or replace any part(s) which, upon examination, inspection, and testing by Generac Power Systems or a Generac Power Systems Authorized Warranty Service Facility, is found to be defective under normal use and service, in accordance with the warranty schedule set forth below. Any equipment that the purchaser/owner claims to be defective must be returned to, and examined by the nearest Generac Power Systems Authorized Warranty Service Facility. All transportation costs under the warranty, including return to the factory, are to be borne and prepaid by the purchaser/owner. This warranty applies only to Generac Power Systems Transfer Switch applications, as Generac Power Systems, Inc. have defined Transfer Switch application, provided said Transfer Switch has been initially installed and inspected on-site by a Generac Power Systems Authorized Service Dealer or branch thereof. A scheduled maintenance agreement with a local Authorized Generac Power Systems Dealer is highly recommended to verify adequate service has been performed on the unit throughout the warranty period.

WARRANTY SCHEDULE

- **YEAR ONE** — 100% (one hundred percent) coverage on mileage*, labor, and parts listed.
- **ALL COMPONENTS**
- **YEAR TWO** — 100% (one hundred percent) coverage on parts listed.
- **ALL COMPONENTS — *PARTS ONLY**
- *Travel allowance is limited to 300 miles maximum, or 7.5 hours maximum (per occurrence), **round trip**, to the nearest authorized Generac Service Facility.
- A Generac Power Systems, Inc. Transfer Switch is highly recommended to be used in conjunction with the genset. If a non Generac genset is substituted for use and directly causes damage to the Generac Transfer Switch, no warranty coverage shall apply.
- All warranty expense allowances **are** subject to the conditions defined in Generac Power Systems Warranty, Policies, and Procedures Flat Rate Manual.
- Units that have been resold **are not** covered under the Generac Power Systems Warranty, as this Warranty **is not** transferable.

THIS WARRANTY SHALL NOT APPLY TO THE FOLLOWING:

1. Any unit built/manufactured prior to January 1, 2002.
2. Unit enclosure is only covered against rust or corrosion the first year of the warranty provision.
3. Costs of normal maintenance i.e. tune-ups, associated part(s), adjustments, loose/leaking clamps, installation and start-up.
4. Use of Non-Generac replacement part(s) will void the warranty in its entirety.
5. Any failure caused by contaminated fuels, oils, coolants/antifreeze or lack of proper fuels, oils or coolants/antifreeze.
6. Failures due, but not limited to, normal wear and tear, accident, misuse, abuse, negligence, or improper installation or sizing.
7. Failures caused by any external cause or act of God such as collision, fire, theft, freezing, vandalism, riot or wars, lightning, earthquake, windstorm, hail, volcanic eruption, water or flood, tornado, hurricane, terrorist acts or nuclear holocaust.
8. Products that are modified or altered in a manner not authorized by Generac Power Systems in writing.
9. Any incidental, consequential or indirect damages caused by defects in materials or workmanship, or any delay in repair or replacement of the defective part(s).
10. Failure due to misapplication, misrepresentation, or bi-fuel conversion.
11. Telephone, telegraph, teletype or other communication expenses.
12. Living or travel expenses of person(s) performing service, except as specifically included within the terms of a specific unit warranty period.
13. Rental equipment used while warranty repairs are being performed i.e. rental generators, cranes, etc..
14. Overtime labor or more than one person performing repairs.
15. Any and all expenses incurred investigating performance complaints unless defective Generac materials and or workmanship were the direct cause of the problem.
16. *Engine coolant heaters (block-heaters), heater controls and circulating pumps after the first year.
17. *Starting batteries, fuses, light bulbs, and engine fluids, tires, brakes and overnight freight cost for replacement part(s).

THIS WARRANTY IS IN PLACE OF ALL OTHER WARRANTIES, EXPRESSED OR IMPLIED, SPECIFICALLY, GENERAC POWER SYSTEMS MAKES NO OTHER WARRANTIES AS TO THE MERCHANTABILITY OR FITNESS FOR A PARTICULAR PURPOSE. Some states do not allow limitations on how long an implied warranty lasts, so the above limitation may not apply to you.

GENERAC POWER SYSTEMS ONLY LIABILITY SHALL BE THE REPAIR OR REPLACEMENT OF PART(S) AS STATED ABOVE. IN NO EVENT SHALL GENERAC POWER SYSTEMS BE LIABLE FOR ANY INCIDENTAL, OR CONSEQUENTIAL DAMAGES, EVEN IF SUCH DAMAGES ARE A DIRECT RESULT OF GENERAC POWER SYSTEMS, INC. NEGLIGENCE.

Some states do not allow the exclusion or limitation of incidental or consequential damages, so the above limitations may not apply to you. Purchaser/owner agrees to make no claims against Generac Power Systems, Inc. based on negligence.

This warranty gives you specific legal rights. You also may have other rights that vary from state to state.

GENERAC® POWER SYSTEMS, INC. · P.O. BOX 8 · WAUKESHA, WI 53187

PH: (262) 544-4811 · FAX: (262) 544-4851

Bulletin 0166260SBY / Printed in USA 5.02