

GENERAC®

POWER SYSTEMS, INC.

Owner's Manual

GTS "Wn" Type

Automatic Transfer Switch

100 thru 1600 Amp,
600 Volts
Trip-to-Neutral



This manual should remain with the unit.



- ⚠ SAVE THESE INSTRUCTIONS - This manual contains important instructions that should be followed during installation and maintenance of the generator and batteries.** ⚠
- ⚠ Read the following information carefully before attempting to install, operate or service this equipment. Also read the instructions and information on tags, decals, and labels that may be affixed to the transfer switch. Replace any decal or label that is no longer legible.** ⚠
- ⚠ DANGER! Connection of a generator to an electrical system normally supplied by an electric utility shall be by means of suitable transfer equipment so as to isolate the electric system from utility distribution system when the generator is operating (Article 701 Legally Required Standby Systems or Article 702 Optional Standby Systems, as applicable). Failure to isolate electric system by these means may result in damage to generator and may result in injury or death to utility workers due to backfeed of electrical energy.** ⚠

Generac cannot possibly anticipate every possible circumstance that might involve a hazard. The warnings in this manual, and on tags and decals affixed to the unit are, therefore, not all-inclusive. If a procedure, work method or operating technique is used that Generac does not specifically recommend, ensure that it is safe for others. Also, make sure the procedure, work method or operating technique chosen does not render the transfer switch unsafe.

Throughout this publication, and on tags and decals affixed to the generator, DANGER, WARNING, CAUTION and NOTE blocks are used to alert personnel of special instructions about a particular operation that may be hazardous if performed incorrectly or carelessly. Observe them carefully. Their definitions are as follows:

— **⚠ DANGER ⚠** —

After this heading, are instructions that, if not strictly complied with, will result in personal injury or property damage.

— **⚠ WARNING ⚠** —

After this heading, are instructions that, if not strictly complied with, may result in personal injury or property damage.

— **⚠ CAUTION ⚠** —

After this heading, are instructions that, if not strictly complied with, could result in damage to equipment and/or property.

NOTE:

After this heading, are explanatory statements that require special emphasis.

These safety warnings cannot eliminate the hazards that they indicate. Common sense and strict compliance with the special instructions while performing the service are essential to preventing accidents.

Four commonly used safety symbols accompany the DANGER, WARNING and CAUTION blocks. The type of information each indicates follows:

- ⚠ This symbol points out important safety information that, if not followed, could endanger personal safety and/or property.**
- ⚠ This symbol points out potential explosion hazard.**
- ⚠ This symbol points out potential fire hazard.**
- ⚠ This symbol points out potential electrical shock hazard.**

⚠ GENERAL HAZARDS ⚠

- Any AC generator that is used for backup power if a NORMAL (UTILITY) power source failure occurs, must be isolated from the NORMAL (UTILITY) power source by means of an approved transfer switch. Failure to properly isolate the NORMAL and STANDBY power sources from each other may result in injury or death to electric utility workers, due to backfeed of electrical energy.
- Improper or unauthorized installation, operation, service or repair of the equipment is extremely dangerous and may result in death, serious personal injury, or damage to equipment and/or personal property.
- Extremely high and dangerous power voltages are present inside an installed transfer switch. Any contact with high voltage terminals, contacts or wires will result in extremely hazardous, and possibly LETHAL, electric shock. **DO NOT WORK ON THE TRANSFER SWITCH UNTIL ALL POWER VOLTAGE SUPPLIES TO THE SWITCH HAVE BEEN POSITIVELY TURNED OFF.**

- Competent, qualified personnel should install, operate and service this equipment. Adhere strictly to local, state and national electrical and building codes. When using this equipment, comply with regulations the National Electrical Code (NEC), CSA Standard; C22.1 Canadian Electric Code and Occupational Safety and Health Administration (OSHA) have established.
- Never handle any kind of electrical device while standing in water, while barefoot, or while hands or feet are wet. **DANGEROUS ELECTRICAL SHOCK MAY RESULT.**
- Remove all jewelry (such as rings, watches, bracelets, etc.) before working on this equipment.
- If work must be done on this equipment while standing on metal or concrete, place insulative mats over a dry wood platform. Work on this equipment only while standing on such insulative mats.
- Never work on this equipment while physically or mentally fatigued.
- Keep the transfer switch enclosure door closed and bolted at all times. Only qualified personnel should be permitted access to the switch interior.
- In case of an accident caused by electric shock, immediately shut down the source of electrical power. If this is not possible, attempt to free the victim from the live conductor but **AVOID DIRECT CONTACT WITH THE VICTIM.** Use a nonconducting implement, such as a rope or board, to free the victim from the live conductor. If the victim is unconscious, apply first aid and get immediate medical help.
- When an automatic transfer switch is installed for a standby generator set, the generator engine may crank and start at any time without warning. To avoid possible injury that might be caused by such sudden start-ups, the system's automatic start circuit must be disabled before working on or around the generator or transfer switch. For that purpose, a **MAINTENANCE DISCONNECT** is provided inside the transfer switch. Always set the switch to its **MANUAL** position before working on the equipment. Then place a "DO NOT OPERATE" tag on the transfer switch and on the generator.

Safety RulesInside Front Cover

Section 1 – General Information2

1.1 Introduction.....2

1.2 Equipment Description2

1.3 Transfer Switch Data Plate2

1.4 Transfer Switch Enclosure2

1.5 Safe Use Of Transfer Switch2

Section 2 – Installation3

2.1 Introduction to Installation3

2.2 Unpacking3

2.3 Mounting3

2.4 Connecting Power Source and Load Lines3

2.5 Connecting Start Circuit Wires4

2.6 Auxiliary Contacts4

2.7 Time Delay Neutral On-Off Switch5

2.8 Optional Accessories6

Section 3 – Operation6

3.1 Functional Tests & Adjustments6

3.2 Manual Operation6

3.3 Voltage Checks.....8

3.4 Electrical Operation.....9

3.5 Transfer Mechanism9

3.6 Stationary and Moveable Main Contacts9

3.7 Main Contacts Operation9

3.8 Switches and Advisory Lamps9

3.9 System Test Switch9

3.10 Standby-Operating Light10

3.11 Switch Position Lamps10

3.12 Sequence of Operation.....10

3.13 Sequence of Operation Settings12

3.14 Transfer Switch Options12

3.15 Sensor and Timer Adjustments -
Sensing Circuit Board15

3.16 Adjustments On Inphase Monitor
Control Circuit Board16

3.17 Calibrating the Inphase Monitor
Control Circuit Board18

3.18 Circuit Board Switch SW118

3.19 Display.....19

3.20 Exercise Times20

3.21 Pushbuttons.....20

3.22 Programming Examples.....20

3.23 Calibrate Utility Voltage Sensing Circuit Board ...21

Section 4 – Maintenance21

4.1 Operate Transfer Switch21

4.2 Clean and Inspect Transfer Switch21

4.3 Lubrication21

4.4 Main Current Carrying Contacts22

4.5 Nine-Volt Battery22

Section 5 – Mounting Dimensions23

**Section 6 – Wiring Diagrams & Electrical
Schematics.....28**

Section 7 – Exploded Views & Parts Lists50

Section 8 – Warranty.....Back Cover

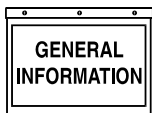

1.1 INTRODUCTION

This manual has been prepared especially for the purpose of familiarizing personnel with the design, application, installation, operation and servicing of the applicable equipment. Read the manual carefully and comply with all instructions. This will help to prevent accidents or damage to equipment that might otherwise be caused by carelessness, incorrect application, or improper procedures.

Every effort has been expended to make sure that the contents of this manual are both accurate and current. Generac, however, reserves the right to change, alter or otherwise improve the product at any time without prior notice.

1.2 EQUIPMENT DESCRIPTION

The automatic transfer switch is used for transferring critical electrical load from a NORMAL (UTILITY) power source to a STANDBY (EMERGENCY) power source. Such a transfer of electrical loads occurs automatically when the NORMAL power source has failed or is substantially reduced and the STANDBY source voltage and frequency have reached an acceptable level. The transfer switch prevents electrical feedback between two different power sources (such as the NORMAL and STANDBY sources) and, for that reason, codes require it in all standby electric system installations.

The transfer switch consists of a solid state intelligence circuit which consists of a utility voltage sensing PCB, an inphase monitor, a seven day exerciser, a transfer mechanism and a control panel.

This transfer switch has trip-to-neutral and transfer permissive capabilities. These features support the load shed and load permissive functions designed into the PowerManager™ controller that is used with MPS products.

◆ 1.2.1 TRIP-TO-NEUTRAL

The Trip-to-Neutral feature serves as a load shed function. A terminal strip is provided for customer connection. When a control circuit (e.g. PM-SC load shed) is closed across these terminals, the GTS contactor is transferred to and mechanically held in a neutral position, isolating the connected load. As long as the control circuit is closed, the transfer switch selector and actuation coils are disabled, keeping the contactor in the neutral position. If the load shed signal is removed, the contactor will transfer to the appropriate position based on available sources.

◆ 1.2.2 TRANSFER PERMISSIVE

The Transfer Permissive function works with the priority load step capability of the PM-SC, where transfer switches are permitted to close onto the MPS emergency bus as generator capacity comes on line. A set of wire terminals are provided on the transfer switch. The GTS will not transfer from utility to generator unless a control circuit (e.g. PM-SC permissive) is closed across these terminals. Note a GTS in the generator position will transfer back to the UTILITY position if utility power is restored, regardless of the transfer permissive signal.

1.3 TRANSFER SWITCH DATA PLATE

A DATA PLATE is permanently affixed to the transfer switch enclosure. Use this transfer switch only with the specific limits shown on the DATA PLATE and on other decals and labels that may be affixed to the switch. This will prevent damage to equipment and property.

When requesting information or ordering parts for this equipment, make sure to include all information from the DATA PLATE.

Record the Model and Serial numbers in the space provided below for future reference.

MODEL #
SERIAL #

1.4 TRANSFER SWITCH ENCLOSURE

The standard switch enclosure is a National Electrical Manufacturer's Association (NEMA) 1 type. NEMA 1 type enclosures (indoor installation only) primarily provide protection against contact with the enclosed equipment and against a limited amount of falling dirt.

1.5 SAFE USE OF TRANSFER SWITCH

Before installing, operating or servicing this equipment, read the SAFETY RULES (inside front cover) carefully. Comply strictly with all SAFETY RULES to prevent accidents and/or damage to the equipment. Generac recommends that a copy of the SAFETY RULES is made and posted near the transfer switch. Also, be sure to read all instructions and information on tags, labels and decals affixed to the equipment.

Two publications that outline the safe use of transfer switches are the following:

- National Electrical Code
- UL 1008, STANDARD FOR SAFETY-AUTOMATIC TRANSFER SWITCHES

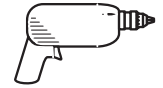

2.1 INTRODUCTION TO INSTALLATION

This equipment has been wired and tested at the factory. Installing the switch includes the following procedures:

- Mounting the enclosure.
- Connecting power source and load leads.
- Connecting the generator start circuit.
- Installing/connecting any options and accessories.
- Functional tests and adjustments.

2.2 UNPACKING

Carefully unpack the transfer switch. Inspect closely for any damage that might have occurred during shipment. The purchaser must file with the carrier any claims for loss or damage incurred while in transit.

Check that all packing material is completely removed from the switch prior to installation.

Attach any lifting device to the transfer switch mounting holes or brackets only. **DO NOT LIFT THE SWITCH AT ANY OTHER POINT.**

2.3 MOUNTING

Mounting dimensions for the transfer switch enclosure are in this manual. Enclosures are typically wall-mounted. Components are generally mounted in a standard NEMA 1-type enclosure. A NEMA 12, 3R, 4 & 4X are also available. See TRANSFER SWITCH OPTIONS, Section 3.14.



- ▲ Handle transfer switches carefully when installing. Do not drop the switch. Protect the switch against impact at all times, and against construction grit and metal chips. Never install a transfer switch that has been damaged.

Install the transfer switch as close as possible to the electrical loads that are to be connected to it. Mount the switch vertically to a rigid supporting structure. To prevent switch distortion, level all mounting points. If necessary, use washers behind mounting holes to level the unit.

2.4 CONNECTING POWER SOURCE AND LOAD LINES



- ▲ Make sure to turn OFF both the NORMAL (UTILITY) and STANDBY (EMERGENCY) power supplies before trying to connect power source and load lines to the transfer switch. Supply voltages are extremely high and dangerous. Contact with such high voltage power supply lines causes extremely hazardous, possibly lethal, electrical shock.

Wiring diagrams and electrical schematics are provided in this manual. Power source and load connections are made at a transfer mechanism, inside the switch enclosure.

◆ 2.4.1 TRANSFER MECHANISMS

The transfer mechanism may be either a 2-pole, 3-pole, or 4-pole type (Figure 2.1). The switch enclosure may include a NEUTRAL BLOCK for connection of the NEUTRAL line. Connect power source and load leads to transfer mechanism terminal lugs as follows:

- LOAD Leads: Connect to terminals T1, T2, T3, etc.
- NORMAL (UTILITY) Source Leads: To terminals N1, N2, N3, etc.
- STANDBY (EMERGENCY) Source Leads: Connect to transfer mechanism terminal lugs E1, E2, E3, etc.

Figure 2.1 — Transfer Mechanism

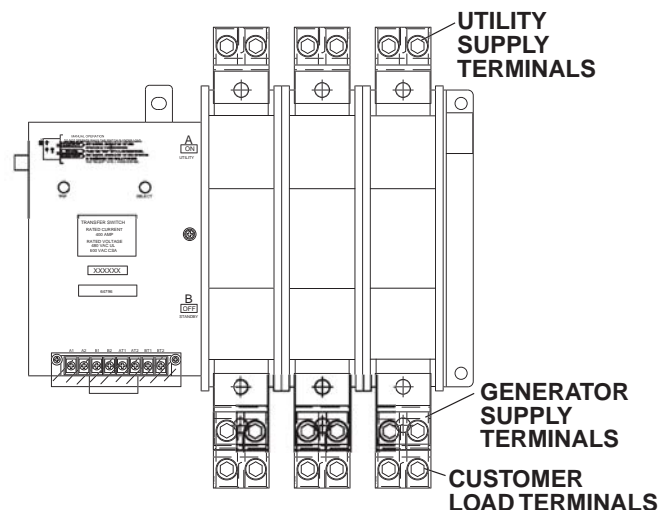

NOTE:

Unless otherwise specified, a NEUTRAL block is not supplied with the transfer switch on single phase, 3-pole units where the NEUTRAL line is to be switched during transfer action. Similarly, a NEUTRAL block is not supplied on three-phase, 4-pole units where the NEUTRAL line is to be switched during transfer.

Solderless, screw-type terminal lugs are standard. Conductor sizes must be adequate to handle the maximum current to which they will be subjected. The installation must comply fully with all applicable codes, standards and regulations.

Before connecting wiring cables to terminals, remove any surface oxides from the cable ends with wire brush. If ALUMINUM conductors are used, apply joint compound. Tighten terminal lugs to the torque values on page 4.

All power cables should enter the switch next to transfer mechanism terminals. Standard terminal lugs on the transfer mechanism are solderless, screw-type.

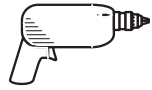

Section 2 – Installation

Generac GTS “Wn” Type Transfer Switch



Use a torque wrench to tighten the conductors, being sure not to overtighten, or damage to the switch base could occur. If not tightened enough, a loose connection would result, causing excess heat which could damage the switch base.

Recommended wire gauge sizes for this wiring depends on the length of the wire, as recommended below:

MAXIMUM WIRE LENGTH	RECOMMENDED WIRE SIZE
460 feet (140m)	No. 18 AWG.
461 to 730 feet (223m)	No. 16 AWG.
731 to 1,160 feet (354m)	No. 14 AWG.
1,161 to 1,850 feet (565m)	No. 12 AWG.

2.6 AUXILIARY CONTACTS

There is access to Auxiliary Contacts on the transfer switch to operate customer accessories, remote advisory lights, or remote annunciator devices. For connection details, consult the relevant annunciator or control panel manual. The contacts shown as FACTORY in Figure 2.3 (page 5) are connected at the factory for operating transfer switch advisory lights. The contacts shown as auxiliary are available for customer use.

Contact operation is shown in the following chart:

	Switch Position	
	Utility	Standby
Common to Normally Open	Closed	Open
Common to Normally Closed	Open	Closed

NOTE:

Auxiliary Contacts are rated 10 amps at 125 or 250 volts AC. DO NOT EXCEED THE RATED VOLTAGE AND CURRENT OF THE CONTACTS.

SWITCH RATING	WIRE SIZE	TORQUE TIGHTENING
100 AMP	#6-2/0 AWG	50 INCH-LBS
200 AMP	#4-400 MCM	375 INCH-LBS
400 AMP	(1) #4-600 MCM or (2) 1/0-250 mcm	375 INCH-LBS
600 AMP	500MCM-1/0	375 INCH-LBS
800/1000 AMP	500MCM-1/0	375 INCH-LBS
1200/1600 AMP	750MCM-1/0	500 INCH-LBS

Be sure to maintain proper electrical clearance between live metal parts and grounded metal. Allow at least one inch for circuits over 400 amps.

2.5 CONNECTING START CIRCUIT WIRES

Connect suitable, approved wiring to transfer switch terminals 178 and 183 (see chart below). Route these wires through suitable, approved conduit (separate from AC conduit) and connect to identically numbered terminals in the AC connection (lower) panel of Generac power systems (engine-generator set). See Figure 2.2.

Closure of Wire 178/183 circuit by switch circuit action must result in generator engine cranking and startup.

Figure 2.2 — Connection Diagram - Three-phase With Neutral Shown (Typical)

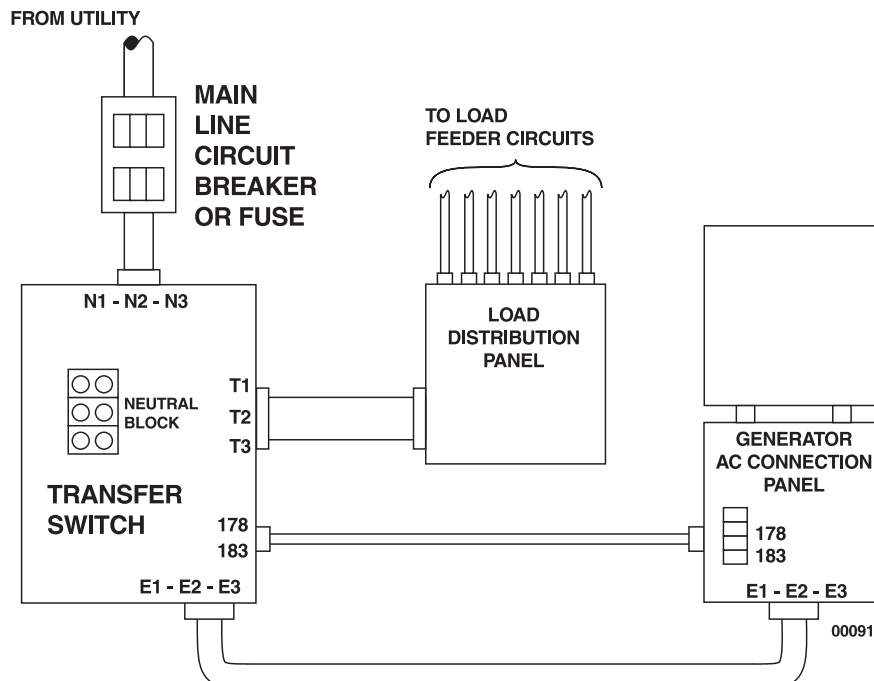



Figure 2.5 — 100A - 200A Auxiliary Contact Diagram

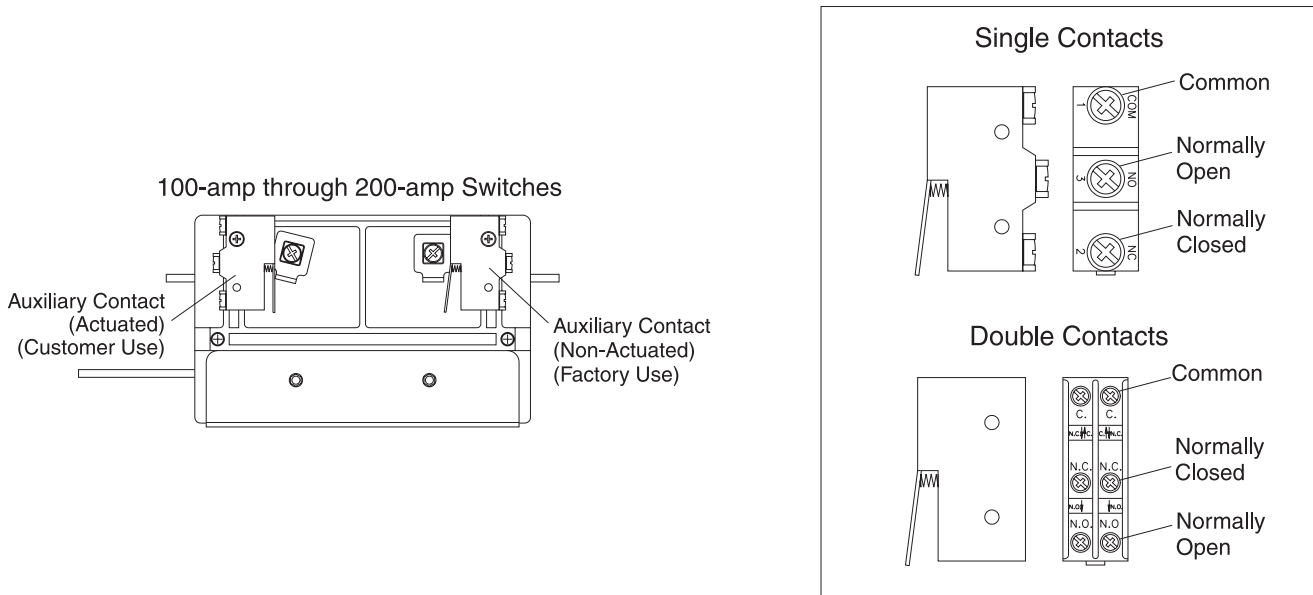
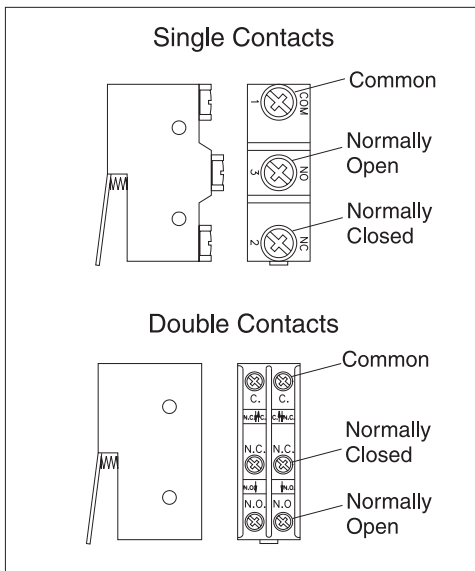
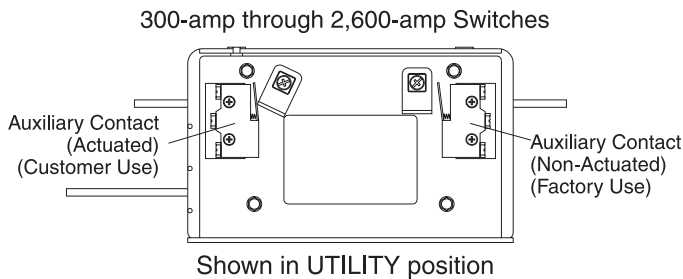

Figure 2.3 — 400 - 2600A Auxiliary Contact Diagram



2.7 TIME DELAY NEUTRAL ON-OFF SWITCH

The Time Delay Neutral feature extends the time that the main contacts normally disconnect. By permitting the LOAD to remain disconnected from both power sources for a fixed time setting, residual voltages generated by heavy inductive loads will decay to a safe level before reconnecting. This provides some protection against nuisances such as blown fuses or circuit breakers that otherwise might occur during a rapid transfer of motor and other heavy inductive loads (Figure 2.4).

Units with the Time Delay Neutral feature are equipped with a Time Delay ON/OFF switch. To eliminate the time delay at neutral during a transfer action, set the switch to OFF.

Figure 2.4 — Time Delay Neutral Switch

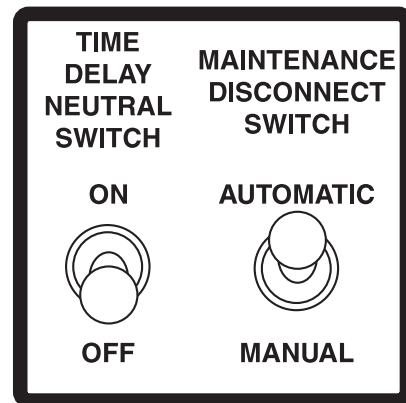

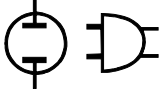

2.8 OPTIONAL ACCESSORIES

Note any optional accessories that may be installed on the transfer switch or are to be installed in the standby electric system in conjunction with the switch. Complete the necessary connections for these accessories.

3.1 FUNCTIONAL TESTS AND ADJUSTMENTS

Following transfer switch installation and interconnection, inspect the entire installation carefully. A competent, qualified electrician should inspect it. The installation should comply strictly with all applicable codes, standards, and regulations. When absolutely certain the installation is proper and correct, complete a functional test of the system. Perform functional tests in the exact order presented in this manual, or damage could occur to the switch.

IMPORTANT: Before proceeding with functional tests, read and make sure all instructions and information in this section are understood. Also read the information and instructions of labels and decals affixed to the switch. Note any options or accessories that might be installed and review their operation.

3.2 MANUAL OPERATION



Do NOT manually transfer under load. Disconnect transfer switch from all power sources by approved means, such as a main circuit breaker(s).

A manual HANDLE is shipped with the transfer switch. Manual operation must be checked BEFORE the transfer switch is operated electrically. To check manual operation, proceed as follows (Figure 3.1):

1. In the transfer switch enclosure, set the Maintenance Disconnect switch to MANUAL. This prevents the generator from starting automatically as soon as UTILITY power source is turned OFF.
2. If so equipped, turn the generator's AUTO-OFF-MANUAL switch to OFF.
3. Turn OFF both NORMAL and STANDBY power supplies to the transfer switch, with whatever means provided (such as the main line circuit breakers).
4. Note position of transfer mechanism main contacts by observing display windows in “A” and “B” in Figure 3.1 as follows:

Figure 3.1 — Actuating Transfer Switch



DANGER: Do NOT manually transfer under load. Disconnect transfer switch from all power sources by approved means, such as a main circuit breaker(s).

Detail of instructions printed on transfer switch

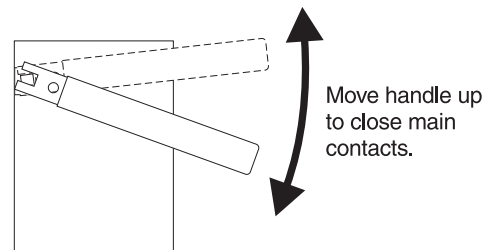
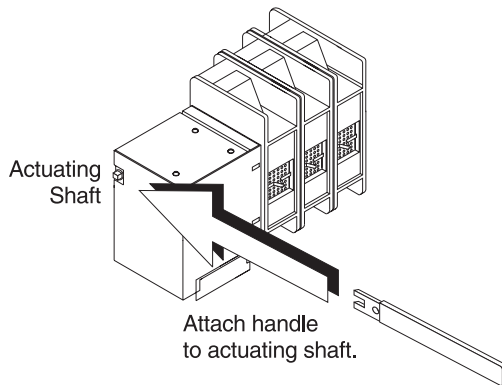
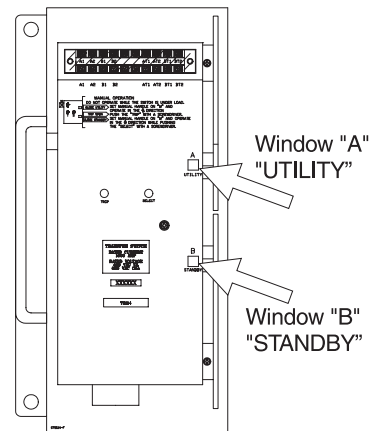
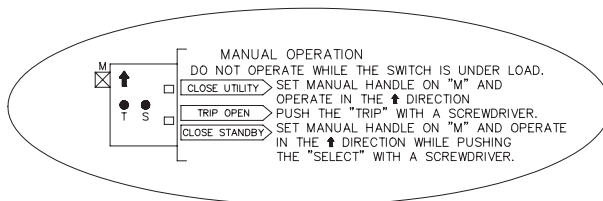

End View

NOTE: Return handle to storage location in enclosure when finished with manual transfer.

- Window “A” ON, Window “B” OFF - LOAD terminals (T1, T2, T3) are connected to NORMAL terminals (N1, N2, N3).
- Window “A” OFF, Window “B” ON - LOAD terminals (T1, T2, T3) are connected to STANDBY terminals (E1, E2, E3).

—▲ CAUTION ▲—

▲ Do not use excessive force when operating the transfer switch manually or damage to the manual handle could occur.

◆ 3.2.1 TRIP TO NEUTRAL POSITION

Remove handle from the square lug at the upper left corner of the switch. Insert a screwdriver into the “T” (Trip) hole and push inward. The main contact should trip to the neutral position and the word OFF should appear in both windows “A” and “B”. See Figure 3.2.

Figure 3.2 — Trip to Neutral

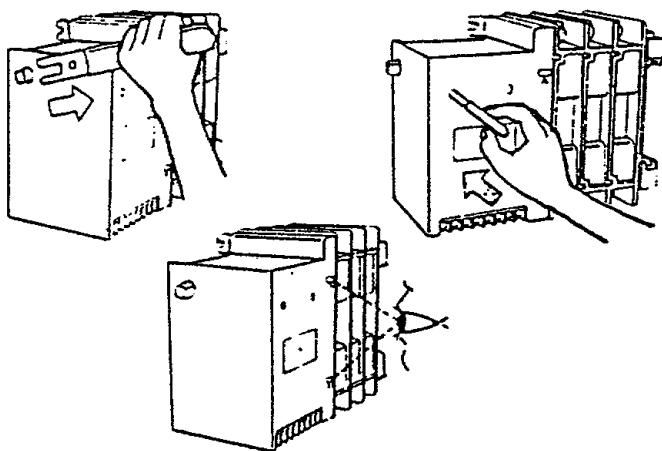

Disconnect manual handle from square shaft. Insert screwdriver into Hole “T” and push in. Confirm “trip” by word “OFF” in both windows “A” and “B”.

◆ 3.2.2 CLOSE TO EMERGENCY SOURCE SIDE

Before proceeding, verify the position of the switch by observing window “A” and window “B”. If window “B” displays ON the ATS is closed in the STANDBY position, with the LOAD connected to the STANDBY source. It is not necessary to manually close in the STANDBY position. See Figure 3.3.

If window “B” reads OFF and window “A” reads ON it will be necessary to trip the ATS to the neutral position. See section 3.2.1.

With handle attached to the actuating shaft. Insert screwdriver into hole marked “S” (Select). While pushing inward on screwdriver, move manual handle upward as indicated by arrow in illustration until it stops. DO NOT FORCE. Confirm main contacts close to STANDBY source when window “B” is ON and window “A” is OFF. Remove handle from switch.

Figure 3.3 — Closure to Emergency Source Side

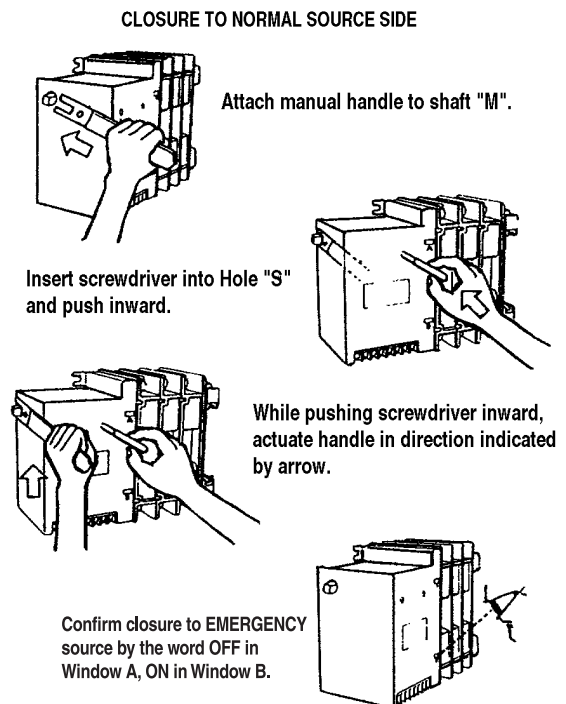

◆ 3.2.3 CLOSE TO NORMAL SOURCE SIDE

Before proceeding, verify the position of the switch by observing window “A” and window “B”. If window “A” reads ON the ATS is closed in the UTILITY position, with the LOAD connected to the NORMAL source. It is not necessary to manually close in the UTILITY position. See Figure 3.4.

If window “A” reads OFF and window “B” reads ON it will be necessary to trip the ATS to the neutral position. See section 3.2.1.

With handle attached to the actuating shaft. Move manual handle upward as indicated by arrow in illustration until it stops. DO NOT FORCE. Confirm main contacts close to UTILITY source when window “A” is ON and window “B” is OFF. Remove handle from switch.

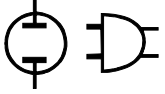
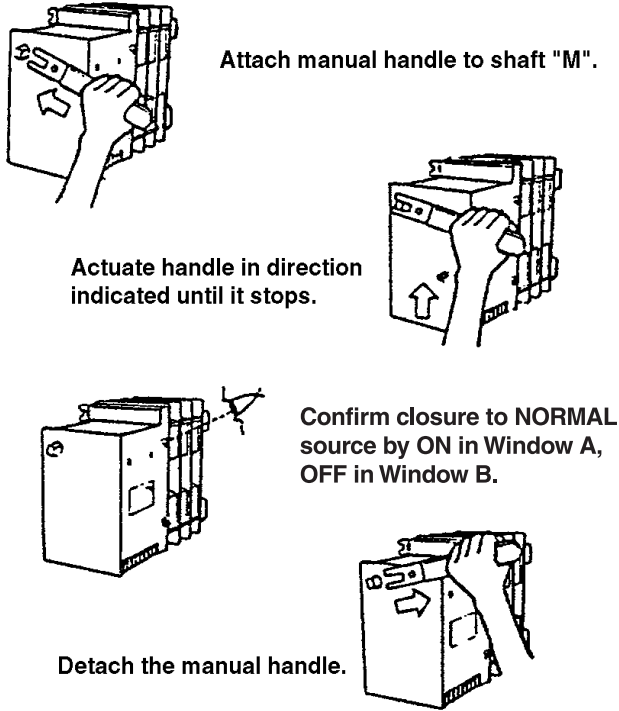

Figure 3.4 — Closure to Normal Source Side



4. Check that the ON indicator is visible in UTILITY Window “A”. See MANUAL OPERATION for location of “A” and “B” windows.

IMPORTANT: DO NOT PROCEED UNTIL STEPS 1, 2, 3, AND 4 HAVE BEEN COMPLETED.

— **CAUTION** —

- Before proceeding to voltage checks, manually connect the load to NORMAL power supply. Window “A” must indicate ON, Window “B” must indicate OFF before proceeding.

5. Turn ON the NORMAL (UTILITY) power supply to the transfer switch, with whatever means provided (such as the main line circuit breaker).

— **DANGER** —

- The transfer switch is now electrically hot. Proceed with caution.

6. With UTILITY voltage available to the transfer switch, check that the SWITCH - POSITION UTILITY LED on the enclosure door is ON. If the SWITCH - POSITION UTILITY LED is OFF, turn off the UTILITY power supply to the transfer switch by whatever means provided (such as the main line circuit breaker(s)), then proceed back to Step 1 of “VOLTAGE CHECKS”.

7. Inside the transfer switch enclosure door, locate the Utility Voltage Sensor Circuit Board. The UTILITY ON LED should be ON. If not, refer to Section 3.23 for calibration.

8. With an accurate AC voltmeter, check the phase-to-phase (line-to-line) and phase-to-neutral (line-to-neutral) voltages present at transfer mechanism terminals N1, N2, N3 and neutral. SUPPLIED VOLTAGES MUST BE FULLY COMPATIBLE WITH TRANSFER SWITCH RATED VOLTAGE.

— **DANGER** —

- Ensure that the phase rotation of NORMAL (UTILITY) power lines and transfer switch load power lines are compatible.

9. Refer to the standby generator instruction manual. Make sure the generator engine has been properly serviced and prepared for use, as outlined in that manual. Then start the generator engine manually. Let the engine stabilize and warm up for a few minutes.

10. Turn ON the STANDBY (GENERATOR) power supply to the transfer switch by whatever means provided (such as the main line circuit breaker).

11. With the generator running, check that the STANDBY - OPERATING LED on the switch enclosure door is ON.

3.3 VOLTAGE CHECKS

— **DANGER** —

- Disconnect all loads from the transfer switch until all voltage checks and phase rotation checks have been completed to prevent possible injury to personnel and, or damage to equipment.

- For safety, set the maintenance disconnect switch (inside transfer switch enclosure) to its MANUAL position before proceeding with voltage checks.

- Before proceeding, check the transfer switch data PLATE for switch rated voltage. Make sure the data plate voltage is compatible with NORMAL and STANDBY power source voltages.

- Proceed with caution. Do not touch electrically hot terminals, wires, etc. During the voltage checks, the transfer switch is electrically energized.

Perform voltage checks as follows:

1. Inside the transfer switch enclosure, set the Maintenance Disconnect switch to MANUAL.
2. If generator is so equipped, set the AUTO-OFF-MANUAL switch to OFF.
3. On the switch enclosure door, set SYSTEM TEST switch to AUTOMATIC MODE position.

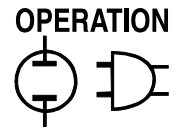

12. With an accurate AC voltmeter, check phase-to-phase (line-to-line) and phase-to neutral (line-to neutral) voltages present at transfer mechanism terminals E1, E2 and E3. Also check AC frequency at those terminals. If frequency is incorrect, the engine governor may require adjustment. Generator AC output voltage and frequency must be compatible with transfer switch rated voltage and frequency.
13. If supplied voltage or frequency is incorrect, refer to standby generator Owner’s Manual. If AC frequency is incorrect, adjust engine governed speed. If voltage is incorrect, adjust generator’s voltage regulator or correct the problem.
14. When supplied voltage and frequency is correct, shut down the engine manually.



Supplied voltages from both NORMAL (UTILITY) and STANDBY (GENERATOR) power sources must be compatible with transfer switch rated voltage before proceeding.

15. Connect the transfer switch load to the transfer switch when “voltage checks” section has been completed. Connect the load to the transfer switch by whatever means provided (such as circuit breaker(s)), then proceed with the “ELECTRICAL OPERATION” section.

3.4 ELECTRICAL OPERATION

Test transfer system electrical operation as follows:

1. On the Utility Voltage Sensor circuit board, check that the UTILITY ON lamp (LED) is ON.
2. On the enclosure door, check that the SWITCH POSITION-UTILITY LED is ON.



The UTILITY ON lamp (on circuit board) and the SWITCH POSITION-UTILITY LED (on enclosure door) must both be ON before proceeding to Step 3.

3. Refer to the appropriate owner’s manual. Be sure the standby generator is prepared for automatic operation.
4. In the switch enclosure, set the Maintenance Disconnect switch to AUTOMATIC.
5. Set the System Test switch to its NORMAL TEST MODE position. Generator startup and transfer to the STANDBY power source should occur. Refer to the SEQUENCE OF OPERATION, Section 3.13.

NOTE:

All systems are equipped with the Inphase Monitor Control board, and advisory lights on the circuit board will light up to indicate operation of the various solid state timers that control automatic operation. By observing these LED’s, the operator can check the automatic operating sequences and times.

See SENSOR AND TIMER ADJUSTMENTS, Section 3.16. For a detailed description of the automatic operating sequences, see SEQUENCE OF OPERATION, Section 3.13.

6. When the test is complete, return the System Test Switch to its AUTOMATIC MODE position. Retransfer back to the UTILITY (NORMAL) power source. The generator should shut down according to circuit board timers.

3.5 TRANSFER MECHANISM

The transfer mechanism main contacts are actuated by an electro-magnetic coil. Power for that coil’s operation is taken from the side to which the LOAD is being transferred. Therefore, transfer to any power source cannot occur unless that power source is available to the switch.

3.6 STATIONARY AND MOVEABLE MAIN CONTACTS

LOAD or “T” contacts, bolted to an insulated plastic sheet, are stationary. The NORMAL (UTILITY) and STANDBY (EMERGENCY) contacts are moveable. The contacts are actuated by means of a closing coil and mechanical linkage. The pole assemblies which retain the stationary and moveable main contacts are assembled together and retained by through-bolts. Either 2, 3 or 4-pole assemblies may be used to form a 2, 3 or 4-pole mechanism.

3.7 MAIN CONTACTS OPERATION

There are three coils inside a “Wn” switch that are used in transferring power to the respective load: a trip coil, a select coil and a closing coil. Working with these coils is a series of limit switches that allow voltage to go to the respective coil for actuation. Refer to the diagnostic repair manual 079247, Section 9.6, for complete operational analysis.

3.8 SWITCHES AND ADVISORY LAMPS

This section familiarizes personnel with switches and advisory lights on the transfer switch enclosure door, as well as with the Maintenance Disconnect Switch inside the switch enclosure.

Circuit boards inside the switch door may also mount several switches. Operation of these switches will be covered in the section entitled SENSOR AND TIMER ADJUSTMENTS.

3.9 SYSTEM TEST SWITCH

This switch allows operator selection of AUTOMATIC, NORMAL TEST or FAST TEST mode operations (Figure 3.5).

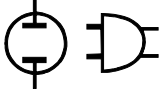

◆ 3.9.1 AUTOMATIC MODE

Use this switch position for all normal automatic operations. With AUTOMATIC MODE selected, any NORMAL source voltage that dropped below a pre-set value will result in the automatic sequence of events listed in the chart in Section 3.13.

◆ 3.9.2 NORMAL TEST MODE

Allows the operator to test automatic operations, just as though an actual drop in NORMAL source voltage had occurred. See the chart in Section 3.13. During the test, observe the LED's on the transfer switch circuit board to monitor automatic operating sequences.

Figure 3.5 — System Test Switch, Standby Operating Light, and Switch Position Light

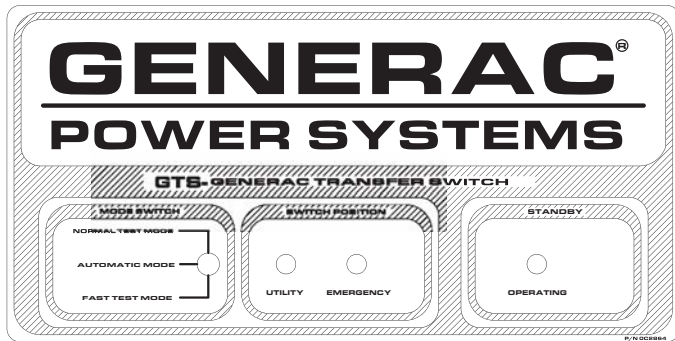

◆ 3.9.3 FAST TEST MODE

Allows the operator to test system operation with all circuit board timers accelerated to less than five seconds. Switch is spring-loaded back to AUTOMATIC MODE, so continuously press the FAST TEST CONTROL. Following the generator startup, loads are transferred to the EMERGENCY (STANDBY) power source as soon as EMERGENCY source voltage and frequency have reached the settings of STANDBY VOLTAGE and STANDBY FREQUENCY sensors on the inphase monitor board.

3.10 STANDBY-OPERATING LIGHT

This LED goes ON to tell the operator that the standby generator is running and that EMERGENCY (STANDBY) source power is available to the transfer switch.

3.11 SWITCH POSITION LAMPS

◆ 3.11.1 EMERGENCY

This LED goes ON when main current-carrying contacts have actuated to their STANDBY (EMERGENCY) position and that power source is available to the transfer switch.

◆ 3.11.2 UTILITY

This LED goes ON when main contacts have actuated to UTILITY (NORMAL) position and that power supply is available to the transfer switch.

3.12 SEQUENCE OF OPERATION

When acceptable NORMAL source voltage is available, observe the following:

- Utility Voltage Sensor circuit board monitor's NORMAL source voltage and UTILITY ON LED is ON.
- Switch Position - UTILITY NORMAL LED is ON.
- Transformer reduced LOAD (T) terminal voltage is delivered to the 7-day exerciser board to operate the 7-day exercise timer.

Automatic timers and sensors on the Inphase Monitor Control circuit board can be monitored by observing the LED's next to the sensor/timer adjustments.

◆ 3.12.1 SEQUENCE 1 - VOLTAGE DROPOUT

- UTILITY source voltage drops below 75-95% of the Voltage Pickup Setting (factory set to about 80%). The UTILITY ON lamp goes OFF.
- Voltage Dropout sensor is factory set to about 80% of “pickup” voltage.
- Voltage dropout below this sensor's setting triggers Sequence 2.

◆ 3.12.2 SEQUENCE 2 - LINE INTERRUPT DELAY

- UTILITY voltage dropout below setting of Voltage Dropout sensor turns on a line Interrupt Delay Timer.
- Line Interrupt Delay can be set for 0.1 to 10 seconds, (factory set to about 5 seconds).
- If voltage dropout lasts longer than Line Interrupt Delay setting, circuit board action closes the automatic start circuit (Wires 178 and 183). When that circuit closes, engine cranks and starts as controlled by a circuit board in the generator's control panel.
- Once the standby generator starts, circuit board is turned ON (go to Sequence 3).

◆ 3.12.3 SEQUENCE 3 - ENGINE MINIMUM RUN AND WARMUP TIMERS

- This timer establishes the minimum length of time for the generator to run before it shuts down. Timer prevents shutdown of a cold engine.
- Timer is adjustable from five to 30 minutes. Factory setting is about 20 minutes.
- An engine warmup timer is also turned ON. This timer permits engine to stabilize and warm up before loads are transferred to STANDBY. Timer is adjustable from five seconds to three minutes. Factory setting is about one minute.

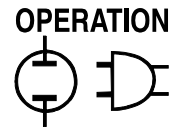

◆ 3.12.4 SEQUENCE 4 - STANDBY VOLTAGE AND FREQUENCY SENSORS

- If generator AC output voltage and frequency is above the setting of these sensors, loads transfer to the STANDBY power source.
- Adjust Standby Voltage Sensor between 85% and 95% or nominal supply voltage. Factory setting is about 90%.
- Adjust Standby Frequency Sensor between 80% and 90% or nominal supply frequency. Factory setting is about 90%.

NOTE:

Bypass the engine warmup timers by setting the Engine Warmup Timer Bypass switch to ON. Loads are transferred to STANDBY as soon as generator AC voltage and frequency have reached the settings of the Voltage and Frequency sensors without having to wait for the engine to warm up.

◆ 3.12.5 SEQUENCE 5 - VOLTAGE PICKUP

- If the UTILITY source voltage is restored above the setting of the Voltage Pickup sensor, Sequence 5 begins.
- Adjust Voltage Pickup between 85% to 95% of the normal supply voltage from the UTILITY source. Factory setting is about 90%.

◆ 3.12.6 SEQUENCE 6 - RETURN TO UTILITY TIMER

- This timer prevents retransfer that a Utility Source voltage surge or transient might cause.
- Adjust timer between one to 30 minutes. Factory setting is about five minutes.
- If UTILITY voltage remains above the setting of the Voltage Pickup Sensor for the time interval of the Return to Utility Timer setting, loads are re-transferred back to the UTILITY source.

◆ 3.12.7 SEQUENCE 7 - ENGINE COOL DOWN TIMER

- After the switch retransfers loads back to UTILITY, this timer starts. When the interval has expired, the automatic start circuit (Wires 178/183) is opened, and the engine shuts down.
- Timer permits engine to run at no-load for a fixed time, so the engine internal temperature can stabilize before shutting down.
- Adjust timer between one to 30 minutes. Factory setting is about 10 minutes.

NOTE:

Actual time between retransfer back to UTILITY and engine shutdown is whichever is longer of the Engine Cool Down timer setting or any time remaining on Engine Minimum run timer.

After the switch automatically retransferred loads back to the UTILITY power source and generator has shut down, the system is “armed” for Sequence 1 again.

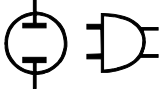

3.13 SEQUENCE OF OPERATION SETTINGS

◆ 3.13.1 UNITS WITH INPHASE MONITOR CONTROL CIRCUIT BOARD

SEQUENCE	ACTION	TIMER/SENSOR	ADJUST RANGE	FACTORY SETTING
—*	UTILITY voltage available - no action	Voltage Dropout Sensor	75 - 95%	90%
A*	UTILITY voltage drops out	Voltage Dropout Sensor	75 - 95%	90%
B	Line Interrupt Delay Timer Starts	Line Interrupt Delay Timer	0.1 - 10 seconds	5 seconds
C	Line Interrupt Delay Timer Stops	Line Interrupt Delay Timer	0.1 - 10 seconds	5 seconds
—	Engine cranks and starts			
D	Engine Minimum Run Timer starts	Engine Minimum Run Timer	5 to 30 minutes	20 minutes
E**	Engine Warmup Timer Starts	Engine Warmup Timer	5 sec. - 3 min.	1 minute
F	STANDBY ON lamp ON			
G**	Engine Warmup Timer stops	Engine Warmup Timer	5 sec. - 3 min.	1 minute
H	Is STANDBY voltage good?	Standby Voltage Sensor	85 - 95%	90%
J	Is STANDBY frequency good?	Standby Frequency Sensor	80 - 90%	90%
K	Time Delay at NEUTRAL	Time Delay Neutral Timer	0.1 - 10 seconds	5 seconds
L	Inphase Transfer	Inphase Transfer Select	None	
—****	Transfer to STANDBY			
M	TRANSFER TO STANDBY lamp ON			
—	STANDBY source powers LOAD			
N	UTILITY voltage restored	Voltage Pickup Sensor	85 - 95%	90%
O	Return to UTILITY Timer ON	Return to Utility Timer	1 - 30 minutes	5 minutes
P	Time Delay at NEUTRAL	Time Delay Neutral Timer	0.1 - 10 seconds	5 seconds
R	Inphase Transfer	Inphase Transfer Select	none	0.1 - 30 seconds
S	Signal Before Transfer LED lights	Signal Before Transfer Timer	1 - 30 seconds	10 seconds
—	Retransfer to UTILITY source			
T***	Engine Cooldown Timer starts	Engine Cooldown Timer	1 - 30 minutes	10 minutes
U***	Engine Cooldown Timer stops	Engine Cooldown Timer	1 - 30 minutes	10 minutes
—	Engine shuts down			
—	UTILITY voltage available - no action			

- * 75 - 95% of the Voltage Pickup Sensor setting
- ** Engine Warmup Timer can be bypassed. See SENSOR AND TIMER ADJUSTMENTS
- *** Following re-transfer to UTILITY source, engine shutdown will not occur until both Engine Minimum run and Engine Cooldown timers have timed out.
- **** Transfer will not occur until the transfer permissive contacts are closed.

3.14 TRANSFER SWITCH OPTIONS

The transfer switch may be equipped with one or more of the following options:

- Instrument Package, 3.14.1
- Signal Before Transfer, 3.14.2
- Remote Auto Control, 3.14.3
- Manual bypass for return to Normal, 3.14.4
- Preferred Source Selector, 3.14.5
- Manual Three-position Selector Switch (Normal-Auto-Standby) 3.14.6
- NEMA 3R, 4, 4X or 12 enclosure, 3.14.7 through 3.14.10

◆ 3.14.1 INSTRUMENT PACKAGE

The optional instrument package includes: (a) an AC voltmeter, (b) an AC ammeter, (c) an AC frequency meter, (d) an hourmeter, and (e) a phase selector switch (Figure 3.6). Several current transformers are required to operate the instrument package, i.e., two for single-phase systems, three for three-phase systems. Use the phase selector switch to select the single-phase voltage and current being read as follows:

SWITCH OPERATION	CURRENT READING	VOLTAGE READING
1	Line 1	Line 1 to Neutral
2	Line 2	Line 2 to Neutral
3	No reading	Line 1 to Line 2
OFF	No reading	No reading

For three-phase systems use the switch as follows:

SWITCH OPERATION	CURRENT READING	VOLTAGE READING
1	Phase A	Phase A to Phase B
2	Phase B	Phase B to Phase C
3	Phase C	Phase C to Phase A
OFF	No reading	No reading

Figure 3.6 — Instrument Package

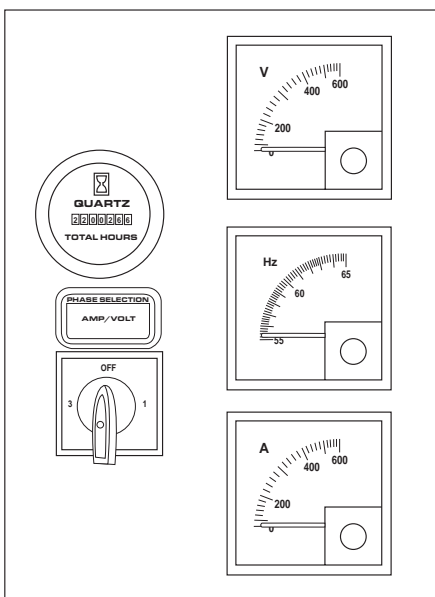

◆ 3.14.2 SIGNAL BEFORE TRANSFER

The Signal Before Transfer option includes a signal relay, customer connection terminal strip and the associated wiring. See Figure 3.7.

The logic for this option is a part of the Inphase Monitor Control PCB. The option is active when the Signal Before Transfer switch is ON. The delay time is adjustable from one to 30 seconds.

The basic operation of the option is to delay (for the period of time set on timer) the transfer of the GTS mechanism while a signal relay (SR) is energized. When the relay is energized, two sets of the dry contacts (wires 236 and 240, 237 and 238) are closed. These dry contacts can be connected to, via a terminal strip located on the bottom of the subplate. Reference wiring diagram - options drawing, for further details. The customer connections are made on terminal strip TS4.

Figure 3.7 — Signal Before Transfer

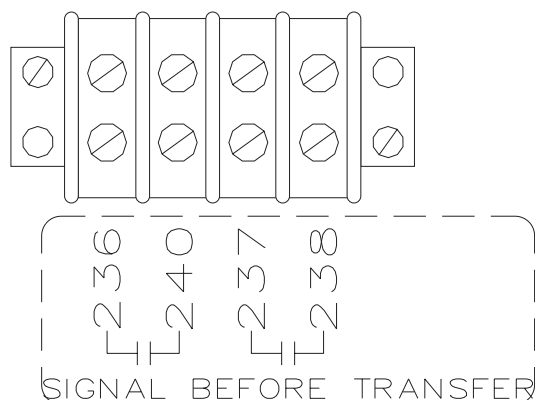

NOTE:

This delay is not active on a Normal source failure. Transfer during Normal source failure is immediate.

NOTE:

The “Signal Before Transfer” feature provides a time delay that allows elevators to continue operating before transfer to another power supply occurs.

◆ 3.14.3 REMOTE AUTO CONTROL

The Remote Auto Control option includes a customer connection terminal strip and the associated wiring (Figure 3.8).

This option allows for remote starting of the generator and transfer of the GTS to connect the LOAD to the EMERGENCY source. This is done by paralleling the Fast Test switch. A description of the Fast Test Mode function can be found in Section 3.9.3.

Reference wiring diagram - options drawing, for further details. The customer connections are made on TS3. The associated wire numbers are 0, 177, 178 and 201.

Figure 3.8 — Remote Auto Control

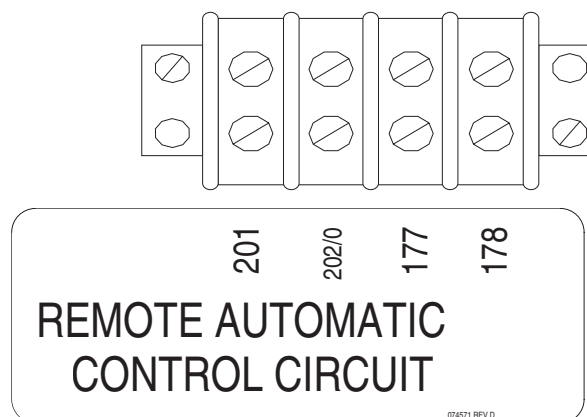

◆ 3.14.4 MANUAL BYPASS FOR RETURN TO NORMAL

The Manual Bypass for Return to Normal option includes a door mounted toggle switch and associated wiring (Figure 3.9).

This option will override the Return to Utility timer on the Inphase Monitor Control PCB. When the toggle switch is activated (pushed down), and the Return to Utility timer is active, the remaining time on the timer is cleared. Once the timer is cleared, the GTS mechanism transfers and the LOAD is connected to the UTILITY source.

If the toggle switch is not activated, the Return to Utility timer functions as normal. The retransfer of the GTS will be delayed until it expires.

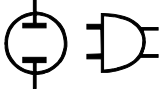
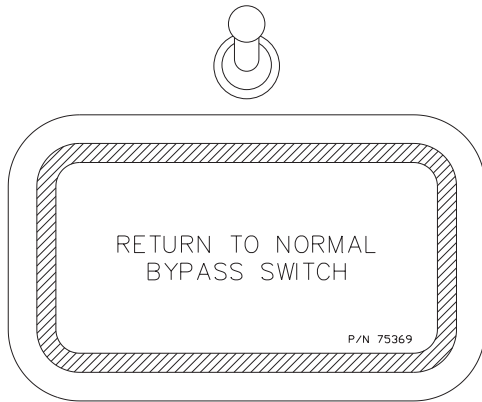

Figure 3.9 — Manual Bypass for Return to Normal



◆ 3.14.5 PREFERRED SOURCE SELECTOR SWITCH

The Preferred Source Selector Switch option includes a door mounted rotary two-position selector switch, customer connection terminal strip and associated wiring (Figure 3.10).

Figure 3.10 — Preferred Source Selector Switch

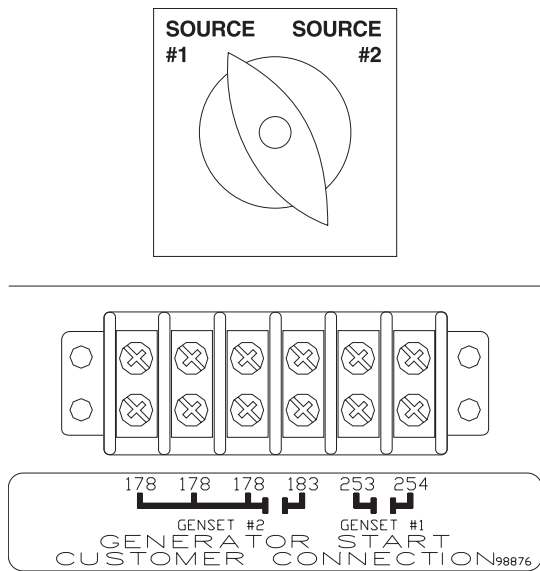

This option is normally used when there is not a UTILITY supply present and both sources are a generator. It may be used when it is desirable for either source of power to serve as the preferred source. The other power source then becomes the backup source. The selector switch is manually operated.

When the rotary switch is in position Source #1, the GTS performs as a normal system. Generator #1 is the primary source and generator #2 is the backup source.

When the rotary switch is in position #2, the GTS signals generator #2 to start and the GTS transfers the LOAD to generator #2. If Source #2 fails, Source #1 is signaled to start. The GTS mechanism transfers the LOAD to Source #1. When Source #2 returns to service, the GTS transfers the Load to Source #2.

Reference wiring diagram - options drawing, for further details. The customer connections are made on TS2. The associated wire numbers are 178, 183, 253 and 254.

◆ 3.14.6 MANUAL THREE-POSITION SELECTOR SWITCH (NORMAL-AUTO-STANDBY)

The Manual Three-position Selector Switch option includes a door mounted rotary three-position selector switch and associated wiring (Figure 3.11).

Under certain conditions, it may be necessary to manually select the active power source. This can be done by means of the door mounted selector switch. The NORMAL - AUTO - STANDBY, three-position selector switch provides the following:

1. When the switch is set to the NORMAL position, the LOAD will be connected to the NORMAL source and any other transfer is inhibited.
2. When the switch is set to the AUTO position, the ATS functions as normal. See the Sequence of Operation section 3.12.
3. When the switch is set to the STANDBY position, the LOAD is connected to the EMERGENCY source and any other transfer is inhibited.

Reference the wiring diagram - options drawing, for further details.

Figure 3.11 — Manual Three-position Switch

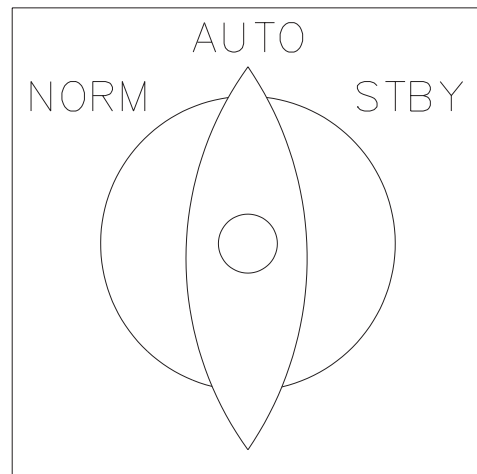

◆ **3.14.7 NEMA 12 ENCLOSURE**

This type of enclosure is intended for use indoors to provide a degree of protection against dust, falling dirt, and dripping, non-corrosive liquids. Contact a Dealer/Distributor for details.

◆ **3.14.8 NEMA 3R ENCLOSURE**

This type of enclosure is intended for use outdoors to protect enclosed parts from windblown dust and water. The enclosure is sealed for dust, rain or sleet and is ice resistant. Contact a Dealer/Distributor for details.

◆ **3.14.9 NEMA 4 ENCLOSURE**

This type of enclosure is intended for use indoors or outdoors to provide a degree of protection against wind-blown dust and rain, splashing water, and hose-directed water and is undamaged by the formation of ice on the enclosure. Contact a Dealer/Distributor for details.

◆ **3.14.10 NEMA 4X ENCLOSURE**

This type of enclosure is intended for use indoors and outdoors to provide a degree of protection against corrosion, windblown dust and rain, splashing water, and hose-directed water and is undamaged by the formation of ice on the enclosure. Contact a Dealer/Distributor for details.

◆ **3.14.11 ADDITIONAL OPTIONS**

For information on additional options not covered in this manual, contact a Dealer/Distributor.

**3.15 SENSOR AND TIMER ADJUSTMENTS
– SENSING CIRCUIT BOARD**

◆ **3.15.1 VOLTAGE DROPOUT SENSOR**

This sensor (Figure 3.12) establishes the NORMAL power source voltage which generator startup and transfer to STANDBY (Emergency) power source occurs. Adjust the sensor to any voltage between 75-95% of the nominal voltage Pickup Sensor setting, by turning the adjusting knob to the desired setting (in percent). Sensor is factory set to about 90% of the Voltage Pickup Sensor setting.

◆ **3.15.2 VOLTAGE PICKUP SENSOR**

Establishes the NORMAL power source voltage at which re-transfer back to that power source occurs. Turn knob to adjust setting to 85-95% of the nominal NORMAL source supply voltage. Sensor has been factory set to about 90% of nominal rated NORMAL source voltage.

◆ **3.15.3 LINE INTERRUPT DELAY TIMER**

Establishes a definite time interval between NORMAL source voltage dropout below the setting of the Voltage Dropout Sensor and generator startup. This time interval is necessary to prevent false generator starts that voltage transients might otherwise cause. Adjust timer from 0.1 to 10 seconds. Factory set to about five seconds.

Figure 3.12 — Sensing Circuit Board Panel

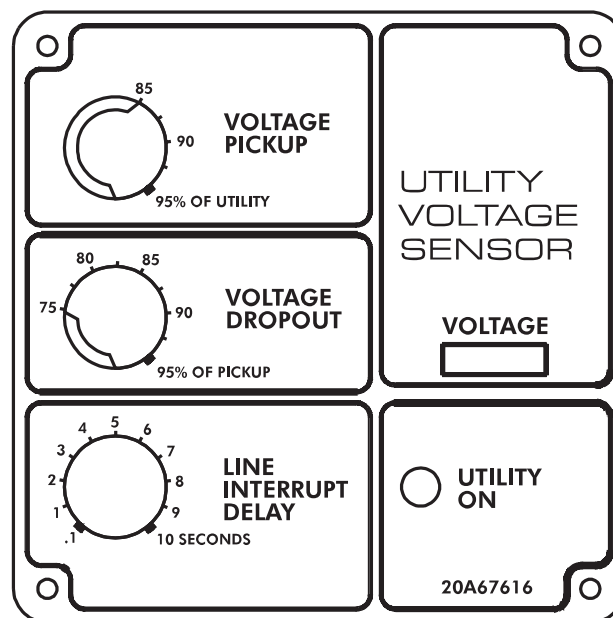

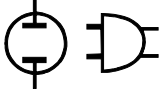

3.16 ADJUSTMENTS ON INPHASE MONITOR CONTROL BOARD

The Inphase Monitor Control board is operational only when the generator set is running and producing electricity. Transfer occurs when UTILITY and GENERATOR voltage and phase are comparatively equal with a maximum difference of 20° between the power sources. To assure precision matching control, minimum voltage and frequency ranges are specified by the operator. In addition, each inphase control is programmed with the use of an onboard DIP switch to match the actuation time of the corresponding switch. Inphase transfer is used only between two live power sources and NOT during a UTILITY source failure. The Inphase Monitor Control board (Figure 3.13) is designed to transfer loads under the following conditions:

- When generator set frequency is between 58-62 Hertz (48-52 Hertz for 50 Hertz systems).
- When generator set and utility power source frequencies are within two Hertz.
- When the generator set and utility source voltage are within 85-100 percent of normal voltage.
- When both power sources are able to come into phase within 10 seconds.
- When less than 10 seconds has elapsed since the engine warmup timer has expired.

If any one of the preceding conditions are not met within 30 seconds, the system automatically reverts to Time delay Neutral (if selected). If Time Delay Neutral is not selected, the switch transfers immediately after failing to do an inphase transfer within the 30 second window.

◆ 3.16.1 ENGINE WARMUP TIMER

Allows the engine to warm up before transferring LOAD from NORMAL to STANDBY power. Reset timer to any time interval between five seconds and three minutes. Factory set to about one minute.

◆ 3.16.2 ENGINE MINIMUM RUN TIMER

Establishes the minimum length of time the generator must run before it can be shut down automatically. Timer prevents a cold engine from being shut down. It is factory set to about 20 minutes, but can be reset to an interval between five and 30 minutes.

◆ 3.16.3 RETURN TO UTILITY TIMER

Establishes time interval between restoration of NORMAL source voltage above the setting of the Voltage Pickup Sensor and re-transfer back to that source. This time interval is necessary to prevent re-transfer that otherwise might occur as a result of transient voltages. Timer can be reset to any interval between one and 30 minutes. Factory set to about five minutes.

Figure 3.13 — Inphase Monitor Control Panel

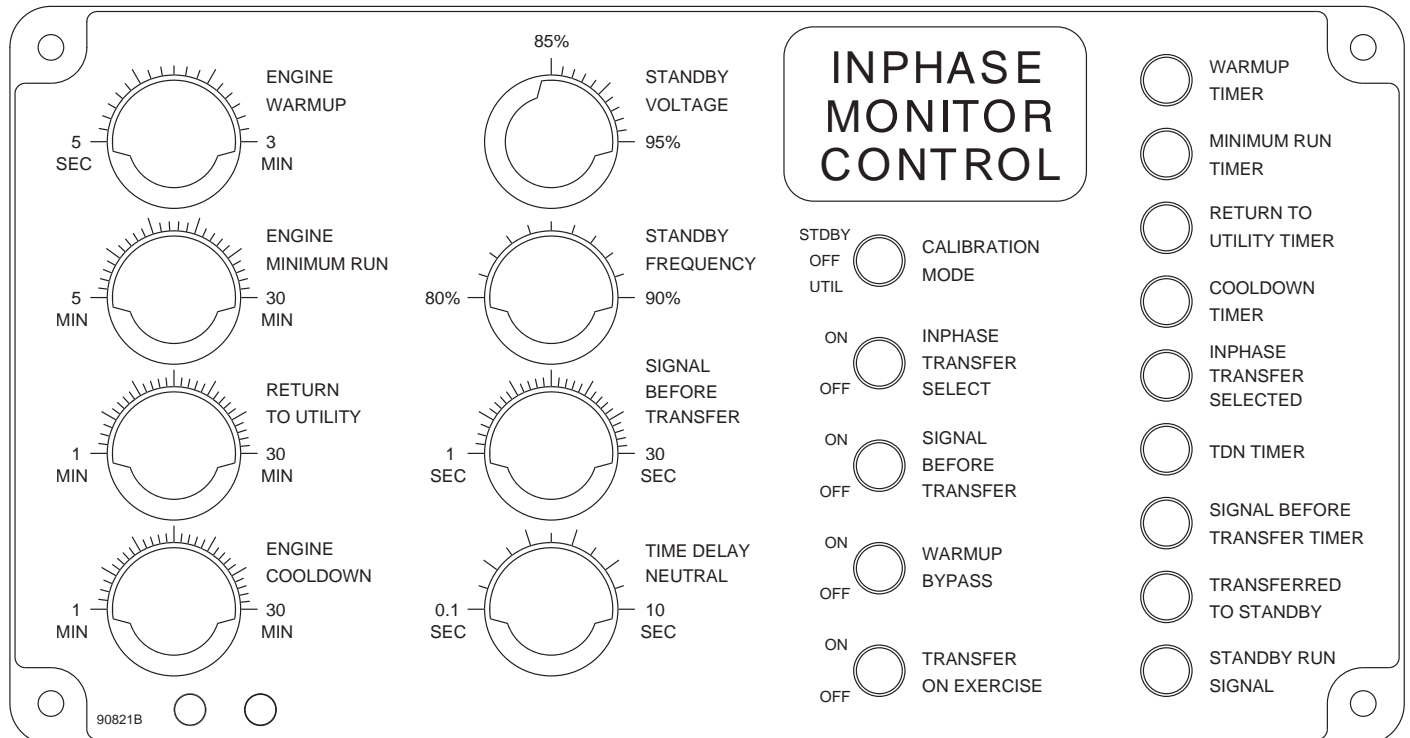

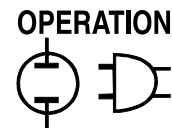

◆ 3.16.4 ENGINE COOL DOWN TIMER

Provides a time delay between automatic re-transfer back to the NORMAL source and engine shutdown. This permits internal engine-generator temperatures to stabilize at “no-load” prior to shutdown. Set timer between one and 30 minutes. Factory set to about 10 minutes.

NOTE:

The actual time interval between re-transfer back to NORMAL and generator shutdown, is the time remaining on Engine Minimum Run timer or time setting of the Engine Cool Down Timer, whichever is longer.

◆ 3.16.5 STANDBY VOLTAGE SENSOR

After engine starts automatically, the system does not transfer LOAD to STANDBY power source until generator AC output voltage has reached the setting of this sensor. Factory set to about 95% of the nominal rated voltage, but can be reset between 85% and 95% of the unit's rated voltage.

◆ 3.16.6 STANDBY FREQUENCY SENSOR

This adjustment allows the installer or operator to select the minimum required frequency of the standby power source. It is adjustable between 80-90%. Factory set to 90%.

◆ 3.16.7 SIGNAL BEFORE TRANSFER TIMER

If selected, this timer controls the amount of time signal remains active. Timer is adjustable from one to 30 seconds. Factory set to about 10 seconds.

NOTE:

The “Signal Before Transfer” feature provides a time delay that allows elevators to continue operating before transfer to another power supply occurs.

◆ 3.16.8 TIME DELAY NEUTRAL

This timer holds the transfer mechanism's main contacts in the “Neutral” position for the time selected. “Neutral” is the main contacts position where the LOAD is disconnected from both UTILITY and STANDBY power supplies. Timer is adjustable from 0.1 and 10 seconds. Factory set to about five seconds.

◆ 3.16.9 CALIBRATION MODE SWITCH

This switch has three positions, identified as “STDBY”, “OFF” and “UTIL”. The switch allows the installer or operator to calibrate the circuit board to the existing generator set output voltage and to the existing UTILITY power source voltage. The board must be calibrated to both power source voltages in order to initiate transfer and re-transfer at the correct voltages. To calibrate the circuit board to the correct voltage, see “Calibrating the Circuit Board.”

◆ 3.16.10 INPHASE TRANSFER SELECT SWITCH

This switch allows the operator or installer to select either “Inphase Transfer” or “Time Delay Neutral” operation. The switch can be positioned as follows:

- Switch at ON: Inphase transfer operation is selected.
- Switch at OFF: Time Delay Neutral is activated, if selected.

◆ 3.16.11 SIGNAL BEFORE TRANSFER SWITCH

This switch allows the operator or installer to select the “Signal Before Transfer” feature or to turn OFF the feature. To activate the feature, set the switch to ON. To turn off the feature, set the switch to OFF.

◆ 3.16.12 ENGINE WARMUP TIMER BYPASS SWITCH

To bypass Engine Warmup Timer and transfer as soon as generator voltage and frequency have reached the setting of the Standby Voltage and Frequency Sensors, set switch to ON. To place Engine Warmup Timer back into the automatic operating system, set the switch to OFF.

◆ 3.16.13 TRANSFER ON EXERCISE SWITCH

For transferring LOAD to the STANDBY source during the 7-day exercise cycle, set switch to ON. For no transfer during the exercise, set switch to OFF.

◆ 3.16.14 ADVISORY LAMPS

The advisory lamps on the Inphase Control board consist of nine LED's and include the following:

- The four red timer LED's turn ON when their respective timers are activated.
- The “Inphase Transfer Selected” LED goes ON when Inphase Transfer Select switch is set to ON, indicating the system will operate in its “Inphase” mode (and NOT in Time Delay Neutral mode).
- The Time Delay Neutral (TDN) Timer LED turns ON when the TDN timer is running.
- The Signal Before Transfer Timer LED turns ON for the duration of the Signal Before Transfer Timer, when it is turned ON.
- Transfer to Standby LED goes ON when LOAD has been transferred to STANDBY power source.
- Standby run Signal goes ON when the generator is running and the Inphase Monitor Control circuit board is operational and controlling the generator.

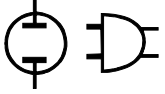

3.17 CALIBRATING THE INPHASE MONITOR CONTROL CIRCUIT BOARD

The Inphase Monitor circuit board must be calibrated to existing STANDBY and UTILITY source voltages if the system is to operate properly. To calibrate the circuit board, two adjustment potentiometers (R102 and R107) are provided in the lower left corner of the circuit board (Figure 3.14). The board must be calibrated as follows:

1. Check that UTILITY supply voltage is available to the system. Set the Maintenance Disconnect switch to the MANUAL position.
2. Start the generator, let it stabilize and warm up.
3. Set the Calibration Mode Switch to “STDBY” and observe the four top LED’s on the circuit board (Warmup Timer, Minimum Run Timer, Return to Utility Timer and Cool down Timer). These are the RED lamps.
 - If the two upper LED’s are illuminated, calibration is set too low.
 - If the two bottom LED’s are illuminated, calibration is set too high.
4. On the circuit board, adjust potentiometer R102 until only the two center LED’s are illuminated (Minimum Run and Return to Utility timers).
5. Now, set the Calibration Mode switch to “UTIL” and observe the four upper LED’s on the circuit board.

Figure 3.14 — Inphase Monitor Control Circuit Board

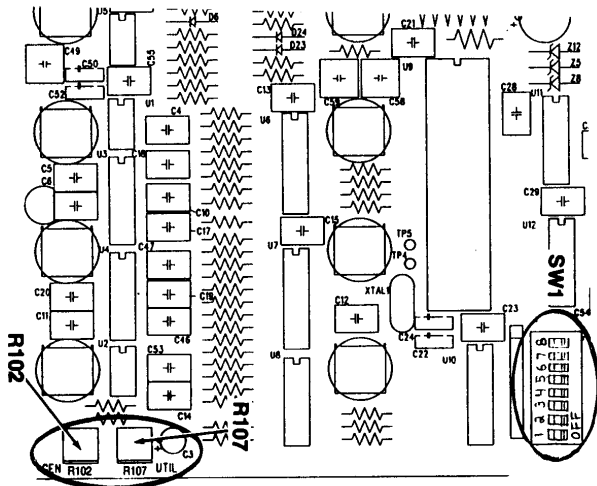

6. Adjust potentiometer R107 until only two center LED’s are illuminated (Minimum Run and Return to Utility).
7. Set the Calibration Mode Switch to “OFF”. The Inphase Monitor Control board is calibrated. Return the Maintenance Disconnect switch to the AUTO position.

NOTE:

With the Calibration Mode Switch set to “STDBY” or “UTIL”, the four top LED’s should turn ON in sequence. That is, the lights should sweep on and off, from one light to the next. Calibration is obtained when the two center lamps of the four (Minimum Run and Return to Utility) are illuminated. This establishes 100% rated voltage.

NOTE:

The Inphase Monitor Control circuit board should be calibrated when the transfer switch has been installed as part of an operating system. Also, replacement circuit boards must be calibrated.

3.18 CIRCUIT BOARD SWITCH SW1

On the Inphase Monitor Control Board, a switch assembly consisting of a bank of eight miniature switches is identified as “SW1” is usually set up at the factory and should require no additional configuring (Figure 3.15).

NOTE:

On boards not installed at the factory, SW1 must be set by the installer. SW1 must be set to match the type of transfer switch in which the board is installed.

The individual switches on SW1 are numbered from “1” (bottom) through “8” (top), as shown in Figures 3.14 and 3.15. To make the circuit board compatible to the specific transfer switch assembly, set the switches as indicated in the chart at the top of page 19. Improper settings may cause transfer outside the 20-degree specification.

Figure 3.15 — Circuit Board Switch SW1

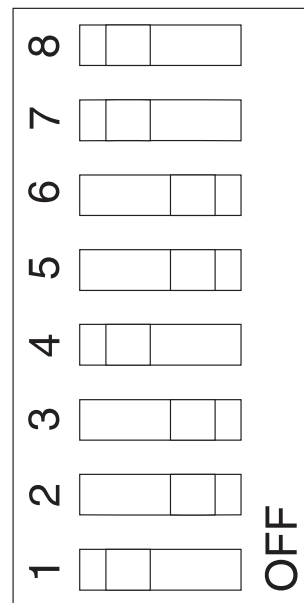

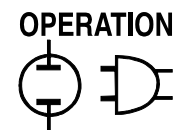

DIP Switch Settings - Wn-Type Transfer Switches

TRANSFER SWITCH	SWITCH RATED 208 VOLTS								SWITCH RATED 240/416/480/600 VOLTS							
	1	2	3	4	5	6	7	8	1	2	3	4	5	6	7	8
100 amps, 3-pole (064787)	*	on	on	off	on	off	on	off	*	on	on	off	on	on	on	on
100 amps, 4-pole (064788)	*	on	on	off	on	on	off	off	*	on	on	on	off	off	off	off
200 amps, 3-pole (0E4931)	*	on	on	off	on	on	off	on	*	on	on	on	off	off	off	on
200 amps, 4-pole (0E7505)	*	on	on	off	on	on	off	off	*	on	on	on	off	off	on	off
400 amps, 3-pole (0E4932)	*	on	on	off	off	on	off	on	*	on	on	off	on	off	off	on
400 amps, 4-pole (0E7506)	*	on	on	off	off	on	on	on	*	on	on	off	on	on	off	off
600 amps, 3-pole (072111)	*	on	off	off	on	on	on	on	*	on	off	on	off	on	on	off
600 amps, 4-pole (072117)	*	on	off	off	on	on	off	on	*	on	off	on	off	on	off	off
800 amps, 3-pole (072113)	*	on	off	off	on	on	off	off	*	on	off	on	off	off	on	off
800 amps, 4-pole (072119)	*	on	off	off	on	on	on	off	*	on	off	on	off	off	on	on
1000 amps, 3-pole (072113)	*	on	off	off	on	on	off	off	*	on	off	on	off	off	on	off
1000 amps, 4-pole (072119)	*	on	off	off	on	on	on	off	*	on	off	on	off	off	on	on
1200 amps, 3-pole (072114)	*	on	off	off	on	off	on	on	*	on	off	on	off	off	off	on
1200 amps, 4-pole (072120)	*	on	off	on	off	on	off	off	*	on	off	off	on	on	off	off
1600 amps, 3-pole (072114)	*	on	off	off	on	off	on	on	*	on	off	on	off	off	off	on
1600 amps, 4-pole (072120)	*	on	off	on	off	on	off	off	*	on	off	off	on	on	off	off

* Set Switch 1 to OFF for 60 Hz systems; set Switch to ON for 50 Hz systems

3.19 DISPLAY (FIGURE 3.16)

◆ 3.19.1 TIME

The time display is used to indicate the current time and exercise time(s) in 12:00 hour format on four, seven segment LED displays. The colon flashes ON/OFF once per second when the current time is displayed and remain ON when an exercise time is displayed. The TIME push-button is used to toggle between the current time and exercise time modes.

The DAY push-button is used to change the day of the week in both the current time and exercise time modes.

◆ 3.19.2 PM (TIME)

A single LED is used to indicate AM (OFF) or PM (ON).

◆ 3.19.3 S M T W T F S (DAY OF WEEK)

Seven individual LEDs are used to indicate the day of the week ('S'unday through 'S'aturday).

◆ 3.19.4 EX (EXERCISE ON)

A single LED is used to indicate when the relay output is switched ON (exercise period).

◆ 3.19.5 POWER SAVING

To minimize power consumption, the unit dims if no keyboard activity is noted for five minutes. The display brightness is reduced by 50% and returns to normal when any key is pressed.

◆ 3.19.6 DEFAULT TIMES

When the Exerciser is first powered up, or if power is removed from the unit and the battery backup has expired, the exerciser reverts to the following settings:

- Current Time: 9:00 AM
- Current Day: Sunday
- Sun through Sat Exercise Time: 9:00 AM
- Exercise Period: 20 minutes

NOTE:

The display flashes '9:00', 'S'unday at a rate of once per second to indicate that line power and battery backup power were lost and that the exerciser must be reprogrammed.

Figure 3.16 — Display

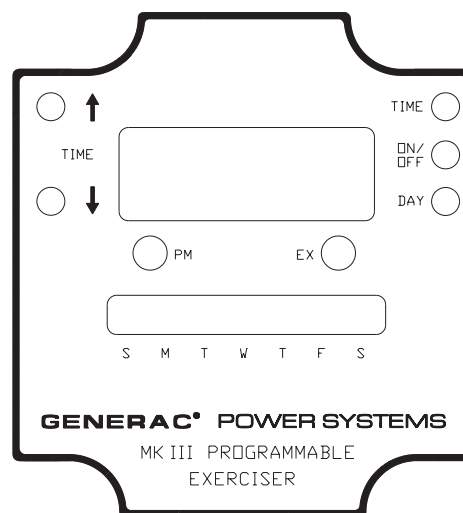

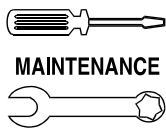

MAINTENANCE

Section 3 – Operation

Generac GTS “Wn” Type Transfer Switch

3.20 EXERCISE TIMES

Each day can be programmed with its own exercise time. Exercise periods can overlap days. For example, if an exercise time is set for 11:55 PM Sunday and the exercise period is set for 20 minutes, the exercise period ends at 12:15 AM Monday.

The exercise period is globally programmable (common to all days), and is limited from 10 to 119 minutes.

3.21 PUSHBUTTONS

◆ 3.21.1 ↑ (UP ARROW)

This push-button is used to increase the time in increments of one minute. This feature has auto-acceleration such that if the button is held down, the step frequency will progressively increase to allow fast setting of a required time. When the button is released and pressed again the step frequency will return to normal.

◆ 3.21.2 ↓ (DOWN ARROW)

This push-button is used to decrease the time in increments of one minute. It also has auto-acceleration.

◆ 3.21.3 TIME (TIME/EXERCISE TIME TOGGLE)

This push-button is used to toggle the display between the current time and exercise time modes. Enabling of the exercise time mode is indicated by the following:

1. The colon stops flashing.
2. The 'S'unday LED flashes to indicate that Sunday is selected. The rate of flashing is either:
 - a. Once per second to indicate the exercise time is disabled.
 - b. Four times per second to indicate the exercise time is enabled.
3. All other days which have their exercise time enabled are indicated by a solid ON LED. Days in which the exercise time is disabled are indicated by a solid OFF LED.

If the display is inadvertently left in the exercise time mode with no keyboard activity for five minutes, it reverts back to the current time mode.

◆ 3.21.4 ON/OFF (EXERCISE ENABLE TOGGLE)

When in exercise time mode, this push-button is used to enable or disable the currently selected day's exercise time. The rate of flashing will change as described in section 3.21.3 above.

◆ 3.21.5 DAY (DAY OF WEEK)

This push-button is used to step forward through the days of the week in both the current time and exercise time modes.

1. In current time mode the days will step through seven states indicating 'S'unday through 'S'aturday.
2. In exercise time mode the days step through seven states indicating 'S'unday through 'S'aturday, and will then display state eight in which all the day LEDs flash ON and OFF together, indicating the global exercise time period mode. In this mode the exercise period can be changed using the Up and Down arrows. The exercise period is limited from 10 to 119 minutes.

3.22 PROGRAMMING EXAMPLES

◆ 3.22.1 EXAMPLE 1: CHANGE THE CURRENT TIME AND DAY FROM 9:00 AM SUNDAY TO 2:00 PM WEDNESDAY

1. Ensure that the current time is displayed as indicated by a flashing colon. If the colon is not flashing, press and release the TIME push-button once.
2. Press and hold the ↑ push-button until the time steps to almost 2:00 PM. Note that the PM LED must be on.
3. Repeatedly press and release the ↑ push-button until '2:00' is displayed. If scrolled past '2:00', use the ↓ push-button to step back until '2:00' is displayed.
4. Press and release the DAY button to advance the day LED display until the 'W'ednesday LED is ON.

◆ 3.22.2 EXAMPLE 2: SET THE EXERCISER ON FOR 14 MINUTES AT 10:00 AM MONDAY THROUGH FRIDAY

1. Press and release the TIME push-button once to display the exercise time for Sunday, indicated by a solid ON colon and a flashing 'S'unday LED. If the colon is still flashing, repeat this step.
2. If the exercise time for Sunday is disabled (default) the 'S'unday LED is flashing once per second. If the LED is flashing four times per second the exercise time is enabled. In this case, press and release the ON/OFF push-button once to disable the exercise time.
3. Press and release the DAY button to advance from Sunday to Monday, indicated by the 'M'onday LED flashing.
4. If the LED is flashing once per second (exercise time disabled), press and release the ON/OFF push-button once. The LED should now be flashing four times per second, indicating that the exercise time is enabled.
5. Use the ↑ and ↓ push-buttons to set the exercise time to 10:00 AM. Once set, the time display should read '10:00' and the PM LED should be OFF.

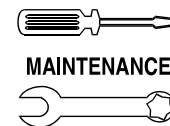

6. Repeat steps three to five for the remaining days of the week, setting and enabling the exercise time for 10:00 AM on Tuesday through Friday, and disabling the exercise time for Saturday.
7. Press and release the DAY button once more. All the day LEDs flash four times per second indicating that the exercise period is displayed (20 minutes default).
8. Use the ↑ and ↓ push-buttons to set the exercise period to 14 minutes (display will read ':14').
9. Press and release the TIME push-button once to return the display to current time mode.

3.23 CALIBRATE UTILITY VOLTAGE SENSING CIRCUIT BOARD

The Utility Sensing Interface reduces utility source voltage at a fixed ratio. Therefore, if utility voltage varies from the nominal, sensing voltage to the circuit board also varies. For that reason, the circuit board must be calibrated to match the system (Figure 3.17).



CAUTION
The installed transfer switch must be rated at a voltage and phase that is compatible with the utility and standby power supplies. DO NOT attempt to calibrate any utility voltage sensor board on any non-compatible unit trying to make the unit compatible.

Once the circuit board has been properly calibrated, the voltage that was present during calibration establishes 100 percent utility voltage for “pickup” and “dropout” settings. Utility source voltage must be available to the transfer switch during calibration.

NOTE:

Use this procedure to calibrate a replacement circuit board. Follow these instructions:

1. In the transfer switch enclosure, set the Maintenance Disconnect Switch to MANUAL.
2. On the Utility Voltage Sensor circuit board, locate test points “TP3” and “TP4” and install a jumper lead.
3. Locate the small potentiometer “R10”. Turn the potentiometer fully counterclockwise.
4. Now, turn the “R10” potentiometer SLOWLY clockwise until the “Utility On” LED just turns ON.
5. Remove the jumper wire from “TP3” and “TP4”.
6. Reset the Maintenance Disconnect switch to AUTOMATIC.

RESULTS:

- If the “Utility On” LED does NOT go on as described above, replace the Utility Voltage Sensor board. Calibrate the new board and perform a “Normal Test” of the system.
- If the “Utility On” LED goes ON, discontinue the test.

Figure 3.17 — Utility Voltage Sensing Circuit Board

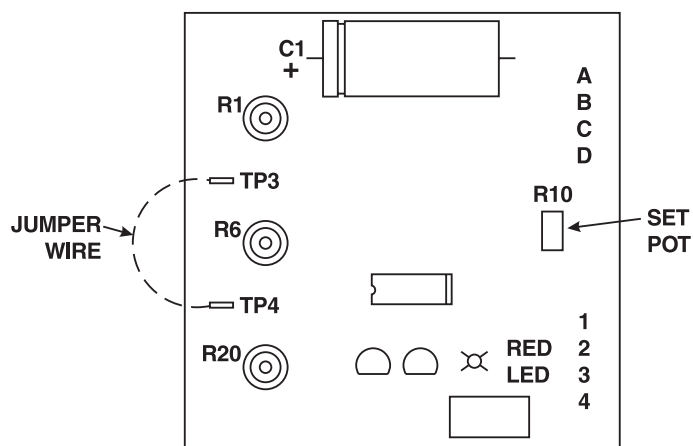

4.1 OPERATE TRANSFER SWITCH

Operate the transfer switch at least once each month. This can be done by performing a NORMAL TEST of the system. Because the System Test switch only simulates failure of the UTILITY power source, service is interrupted only during the actual transfer of the load.

4.2 CLEAN AND INSPECT TRANSFER SWITCH

Protect the transfer switch against construction grit, metal chips, excessive moisture and other harmful dirt at all times. At least once each year turn OFF all power supplies to the switch, then brush and vacuum away dust and dirt that has accumulated inside the enclosure. After cleaning, inspect the transfer switch carefully. Look for evidence of arcing, burning, hot spots, charring and other damage. If any of these are found, have the switch assembly checked by an authorized service technician.

4.3 LUBRICATION

Operating parts inside the transfer mechanism have been properly lubricated at the time of assembly. Under normal conditions, no additional lubrication should be required. The service technician should lubricate all recommended points whenever major transfer mechanism components are replaced.

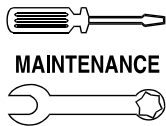

MAINTENANCE

Section 4 – Maintenance

Generac GTS “Wn” Type Transfer Switch



CAUTION



Use only specified greases to lubricate contactor parts. DO NOT USE ANY SUBSTITUTES.

Use the following lubricants for the:

1. Main Contacts (Between movable contact and bus-bars).
 - Dow Corning (Molykote) BR2 Plus; (Mfg. by Dow Corning Co., USA)
 - Liqui-Moly (Mfg. by DAI TO Co., Ltd., Japan)
2. Operating Mechanism (Used on the actuator and other parts of the contactors. Excluding the movable contacts).
 - Mobilgrease 28 (Mfg. by Mobil Oil Co.)
 - Mobiltemp SHC 32 (Mfg. by Mobil Oil Co.)
 - Polo Moly Complex Grease #NLG12 (Mfg. by Polo Lubricants, USA)
 - Rheolube 363 (Mfg. by Nye Lubricants Inc., USA)

4.4 MAIN CURRENT CARRYING CONTACTS

At least once annually, have an Authorized Service Technician check the main current-carrying contacts in the transfer mechanism. They will repair or replace major components that have been found defective.

4.5 NINE-VOLT BATTERY

The transfer switch is equipped with an adjustable Inphase Monitor Control circuit board. The battery connects to a separate 7-day exerciser circuit board. Battery power for Exercise Timer operation is only needed during the short time interval when the transfer mechanism main contacts are at NEUTRAL position (LOAD disconnected from both power sources). It is recommended that the nine-volt battery be replaced once each year.

Section Section 5 – Mounting Dimensions
Generac GTS “Wn” Type Transfer Switch

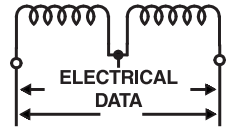

100 Amp (All voltages); 150-400 Amp (208 - 240VAC) NEMA 1 Units

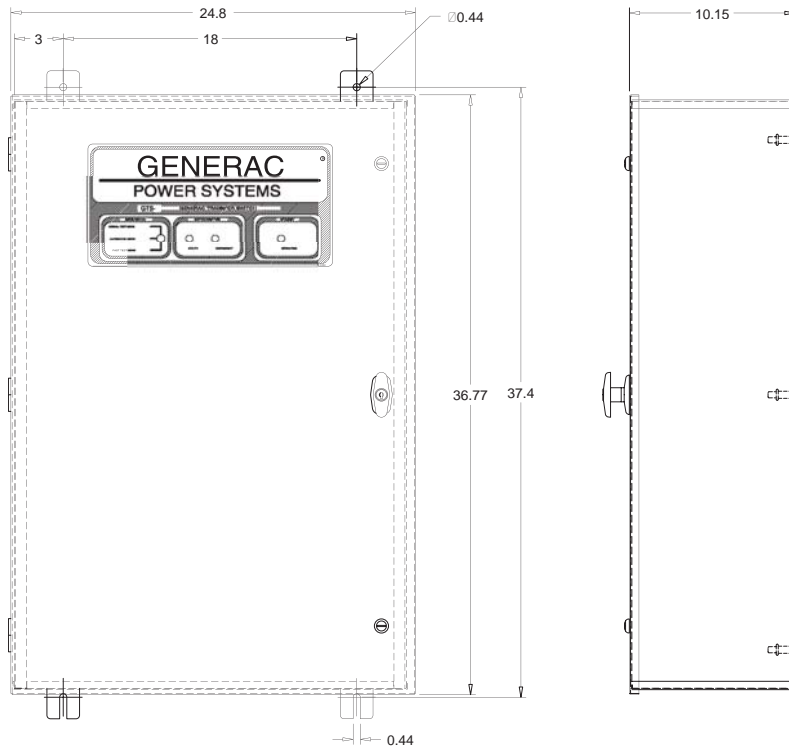

150-400 Amp (480 - 600VAC) NEMA 1 Units

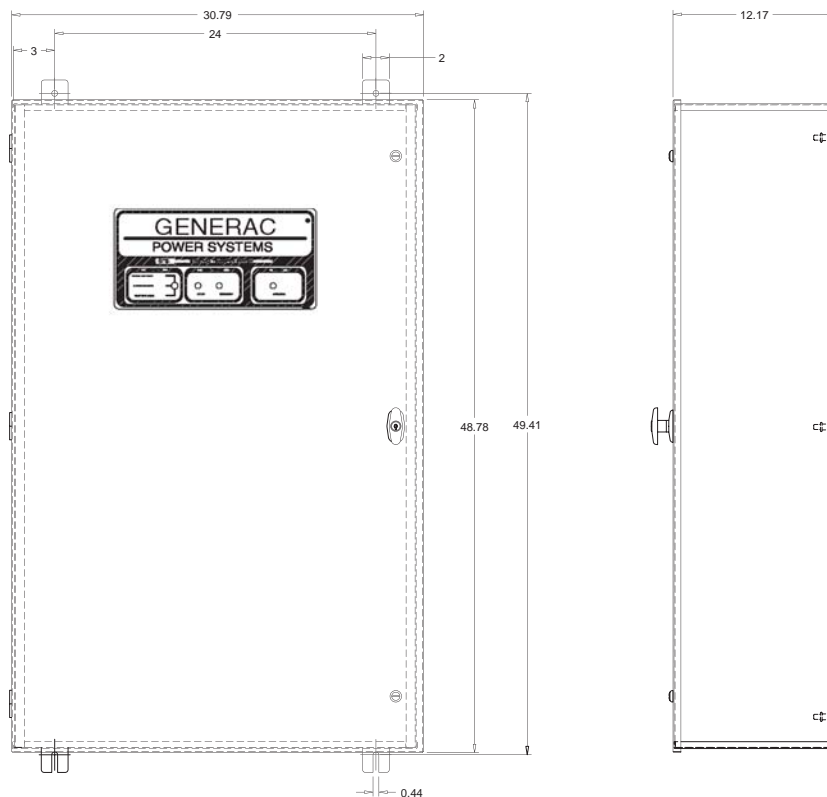

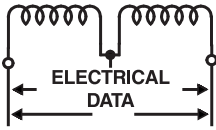

Section Section 5 – Mounting Dimensions

Generac GTS “Wn” Type Transfer Switch

100 Amp (All voltages); 150-400 Amp (208 - 240VAC) 3R, 4, and 4X Units (Typical)

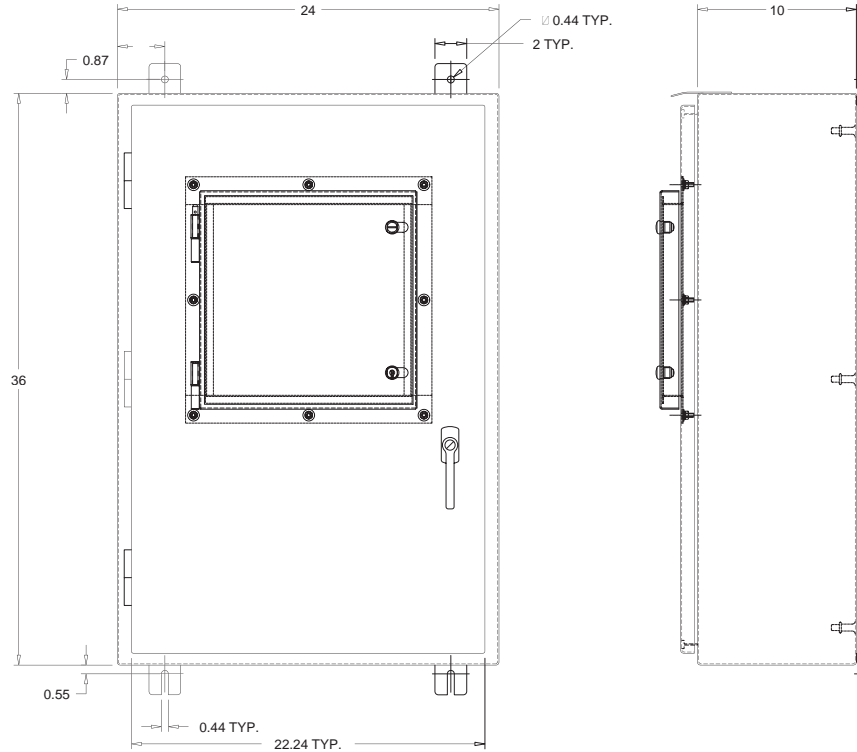

150-400 Amp (480 - 600VAC) 3R, 4 and 4X Units (Typical)

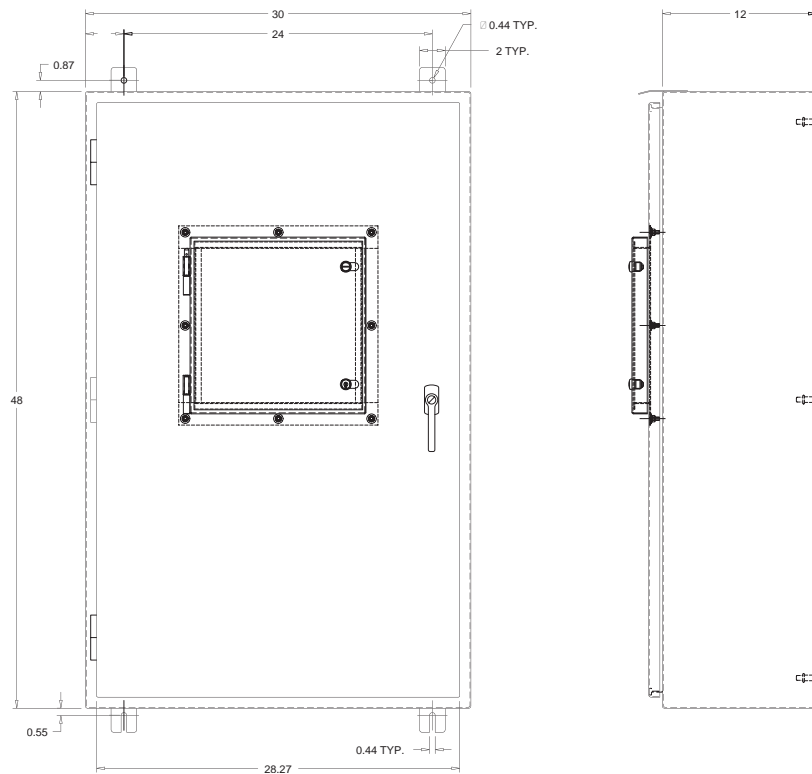

Section Section 5 – Mounting Dimensions
 Generac GTS “Wn” Type Transfer Switch

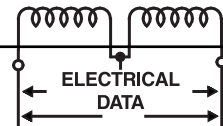

100 Amp (All voltages); 150-400 Amp (208 - 240VAC) NEMA 12 Units With Instrument Package

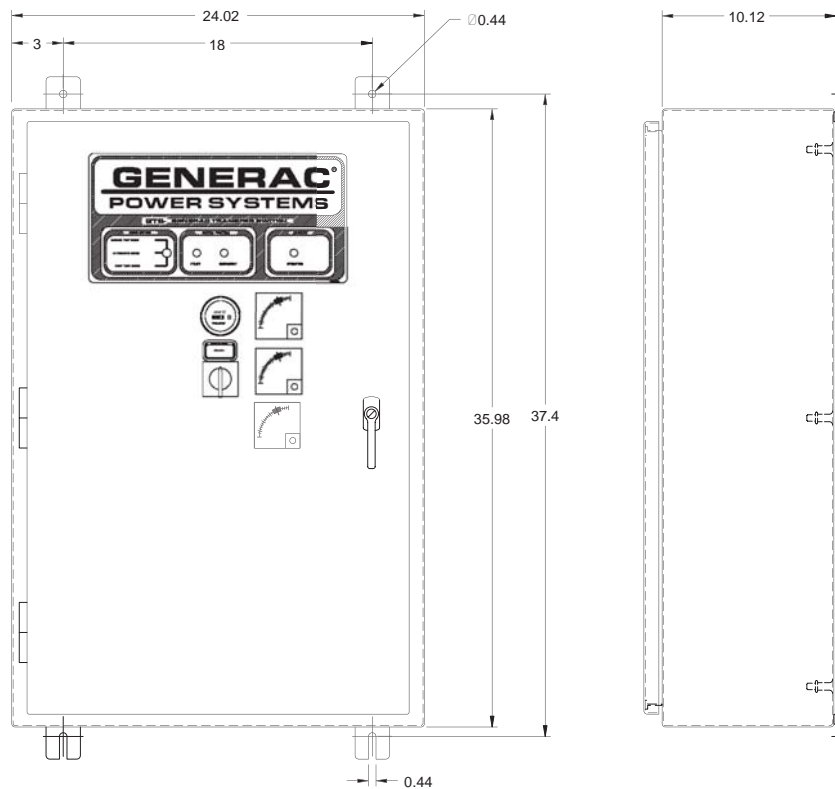

150-400 Amp (480 - 600VAC) NEMA 12 Units With Instrument Package

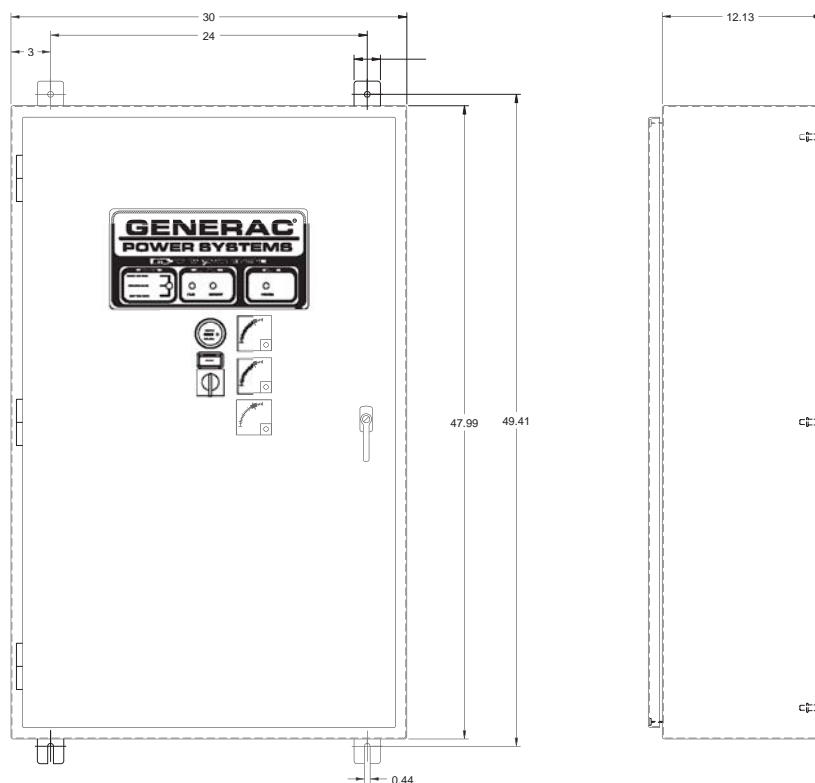

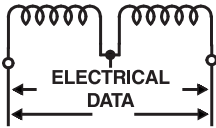

Section Section 5 – Mounting Dimensions

Generac GTS “Wn” Type Transfer Switch

600-1000 Amp NEMA 12 Units

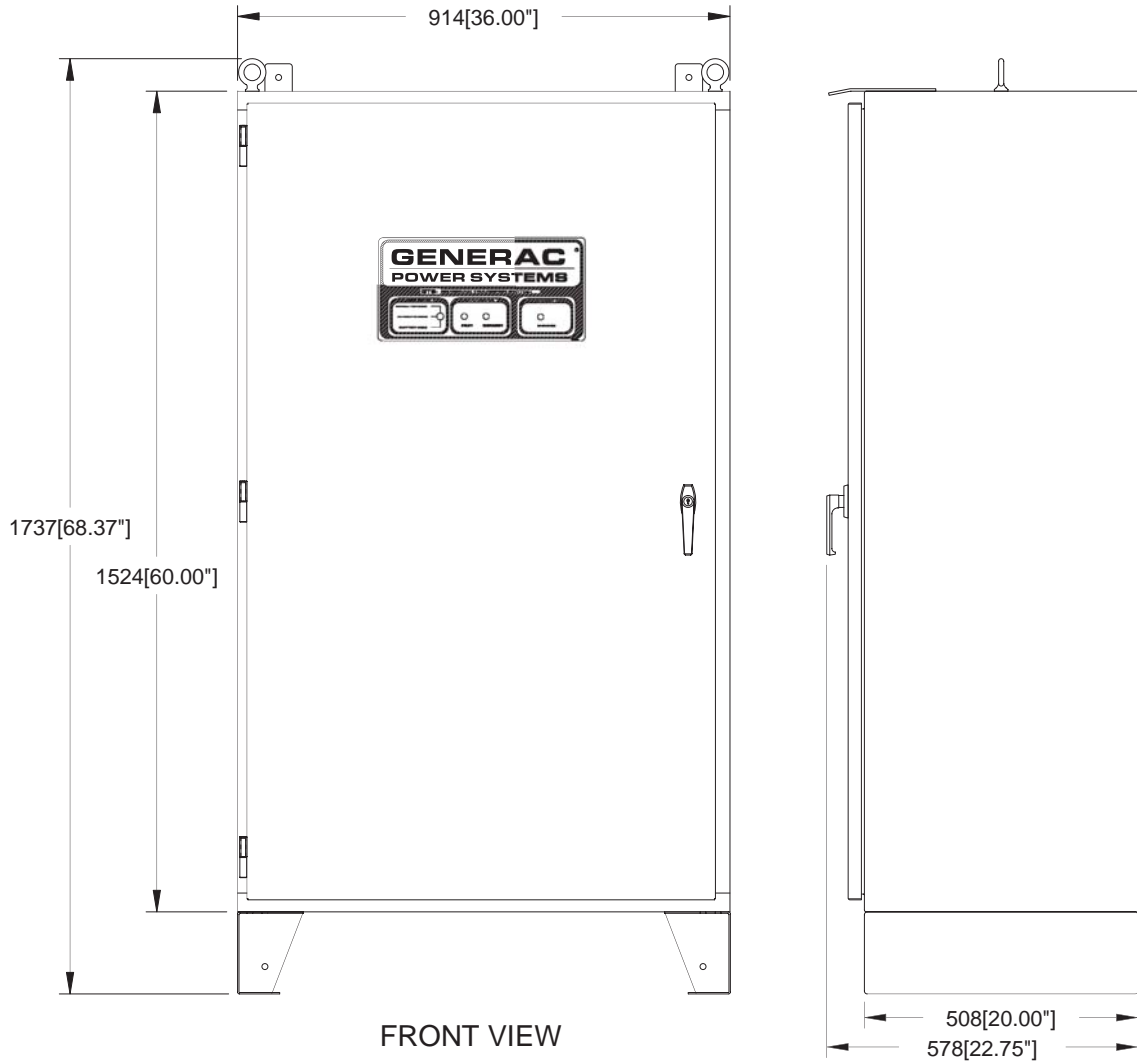

FRONT VIEW

RIGHT SIDE VIEW

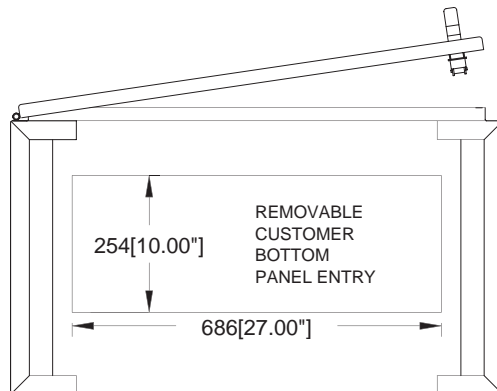

BOTTOM VIEW

Section Section 5 – Mounting Dimensions
Generac GTS “Wn” Type Transfer Switch

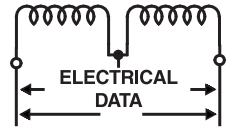

1600 Amp NEMA 12 Units

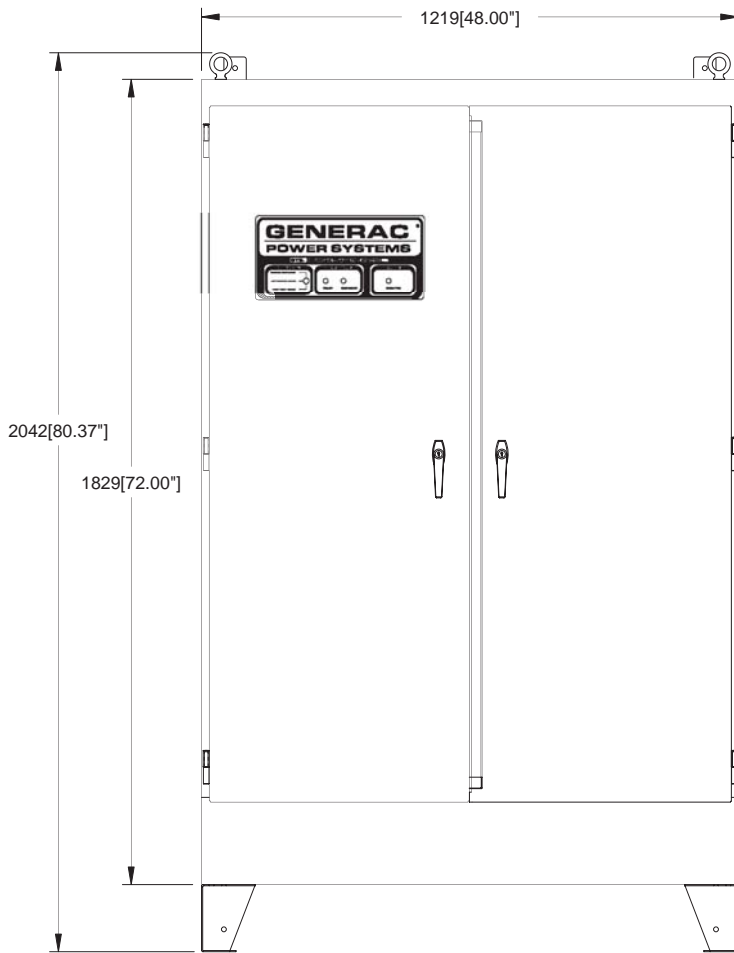

FRONT VIEW

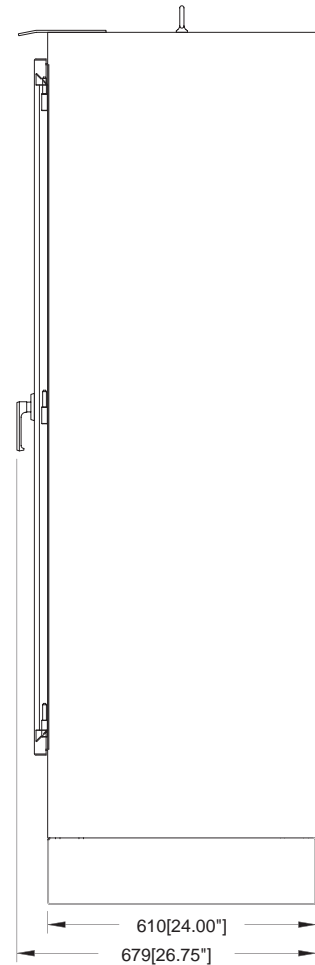

RIGHT SIDE VIEW

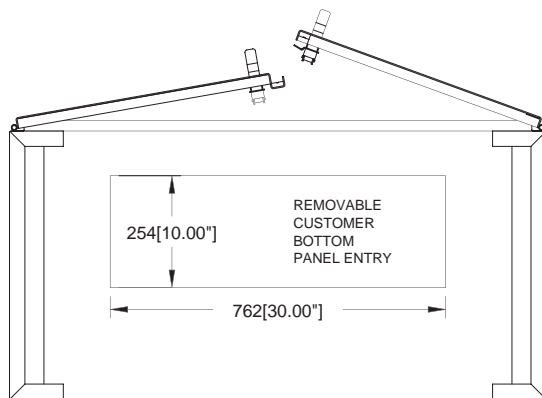

BOTTOM VIEW

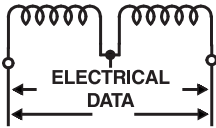

Section 6 – Electrical Schematics and Wiring Diagrams

Generac GTS "Wn" Type Transfer Switch

Electrical Schematic - 208/240V - Drawing No. 0E5321

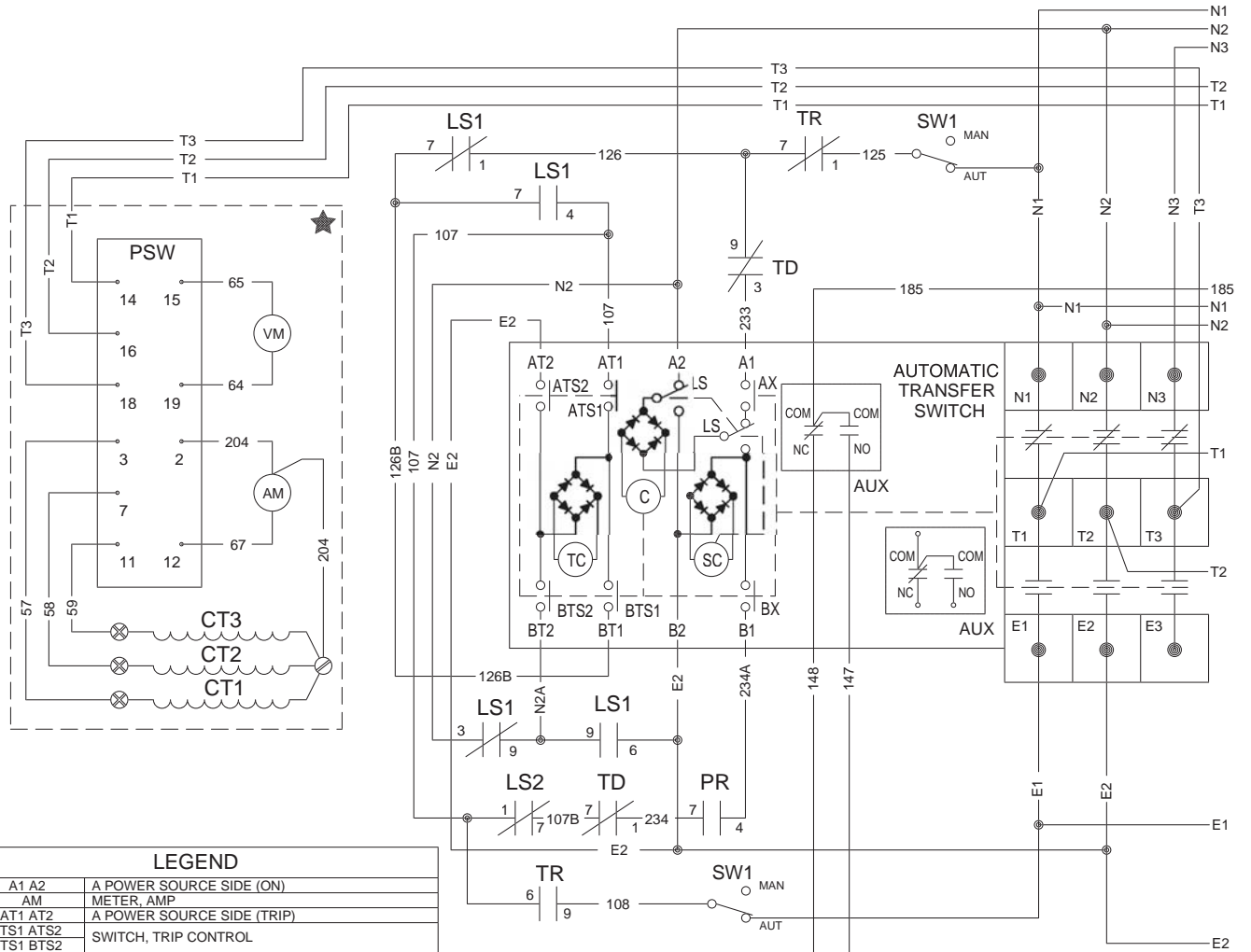

LEGEND	
A1 A2	A POWER SOURCE SIDE (ON)
AM	METER, AMP
AT1 AT2	A POWER SOURCE SIDE (TRIP)
ATS1 ATS2	SWITCH, TRIP CONTROL
BTS1 BTS2	SWITCH, TRIP CONTROL
AUX	SWITCH, AUXILIARY
Ax Bx	SWITCH, CONTROL
B1 B2	B POWER SOURCE SIDE (ON)
BT1 BT2	B POWER SOURCE SIDE (TRIP)
C	COIL, CLOSING
CT1, CT2, CT3	TRANSFORMER, CURRENT (OPT)
F1, 2	FUSE, 1 AMP
FM	METER, FREQUENCY
FWB	FULLWAVE BRIDGE RECTIFIER PKG
HM	METER, HOUR
L1	GREEN LIGHT, SWITCH POSITION UTILITY
L2	RED LIGHT, SWITCH POSITION EMERGENCY
L3	YELLOW LIGHT, STANDBY OPERATING
LS	SWITCH, SELECTIVE
LS1, 2	RELAY, LOAD SHED
PR	RELAY, PERMISSIVE
PSW	SWITCH, PHASE SELECTOR
SC	COIL, SELECTIVE
SW1	SWITCH, MAINTENANCE DISCONNECT
SW2	SWITCH, SYSTEM TEST
SW3	SWITCH, TDN ON/OFF
SW4	SWITCH, RETURN TO NORMAL BYPASS (OPT)
TC	COIL, TRIP
TD	RELAY, TIME DELAY
TR	RELAY, TRANSFER
TR1	TRANSFORMER, STANDBY SENSING
TR2	TRANSFORMER, LOAD POWER SUPPLY
TR3	TRANSFORMER, UTILITY SENSING
VM	METER, VOLT

PSW CONTACTS	POSITION			
	1	2	3	OFF
2 - 3		X	X	X
2 - 7	X		X	X
2 - 11	X	X		X
12 - 3	X			
12 - 7		X		
12 - 11			X	
15 - 14	X			
15 - 18		X	X	
19 - 16	X	X		
19 - 14			X	

X INDICATES CLOSED

OPTIONS	
★	INSTRUMENT PACKAGE
⊖	REMOTE AUTO START
*	RETURN TO NORMAL BYPASS

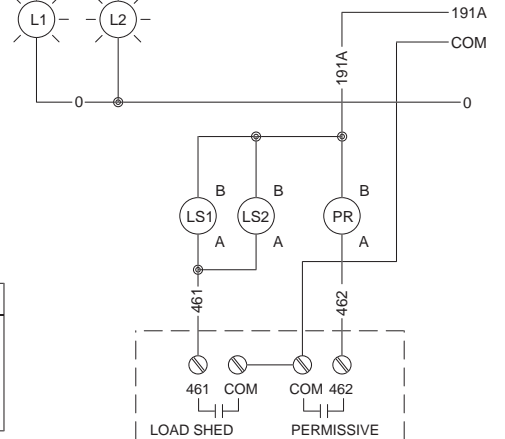

Section 6 – Electrical Schematics and Wiring Diagrams

Generac GTS "Wn" Type Transfer Switch

Electrical Schematic - 208/240V - Drawing No. 0E5321

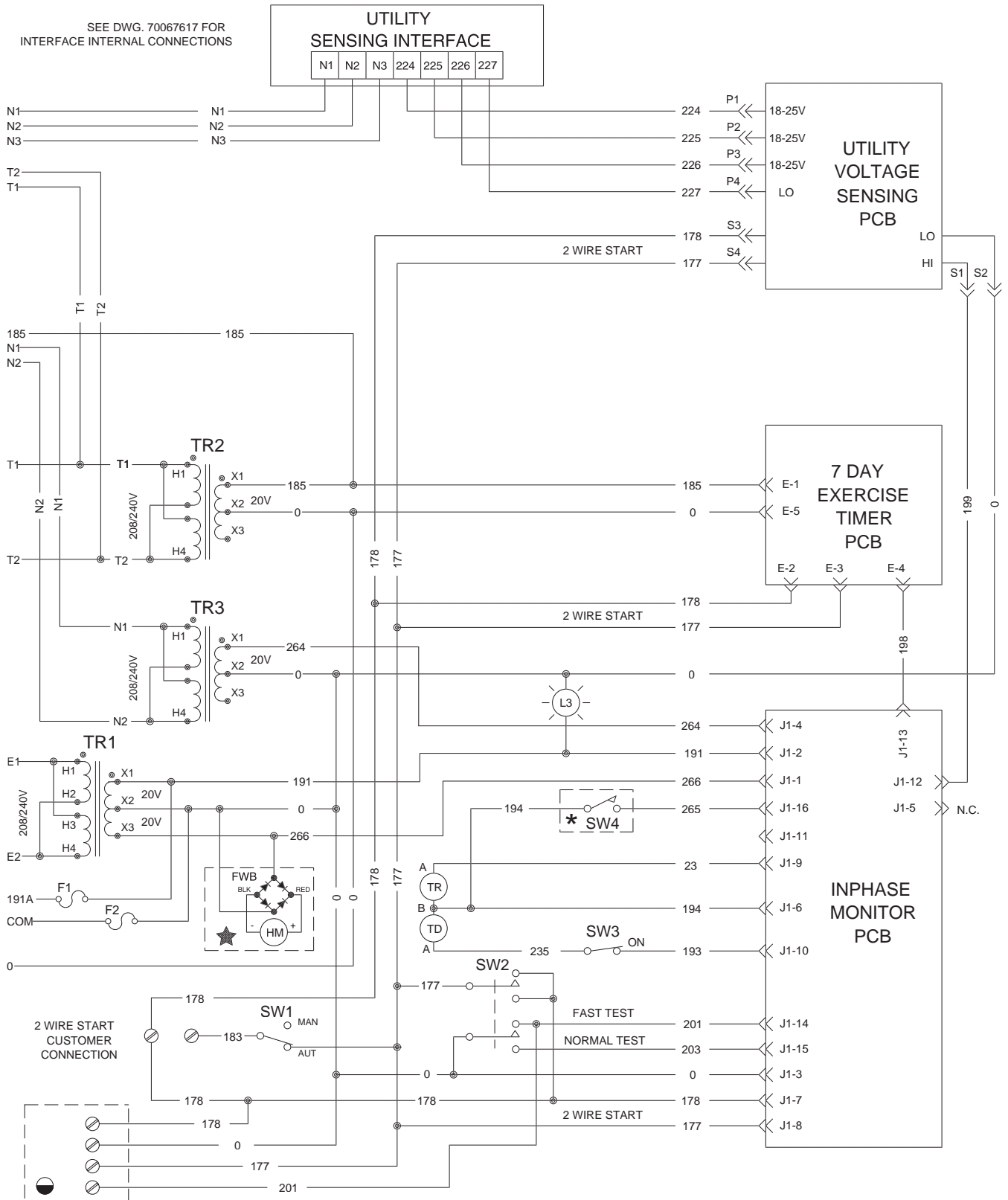
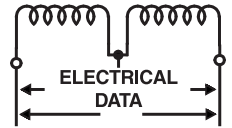

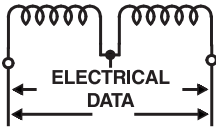

Section 6 – Electrical Schematics and Wiring Diagrams

Generac GTS "Wn" Type Transfer Switch

Wiring Diagram - 208/240V - Drawing No. 0E5317

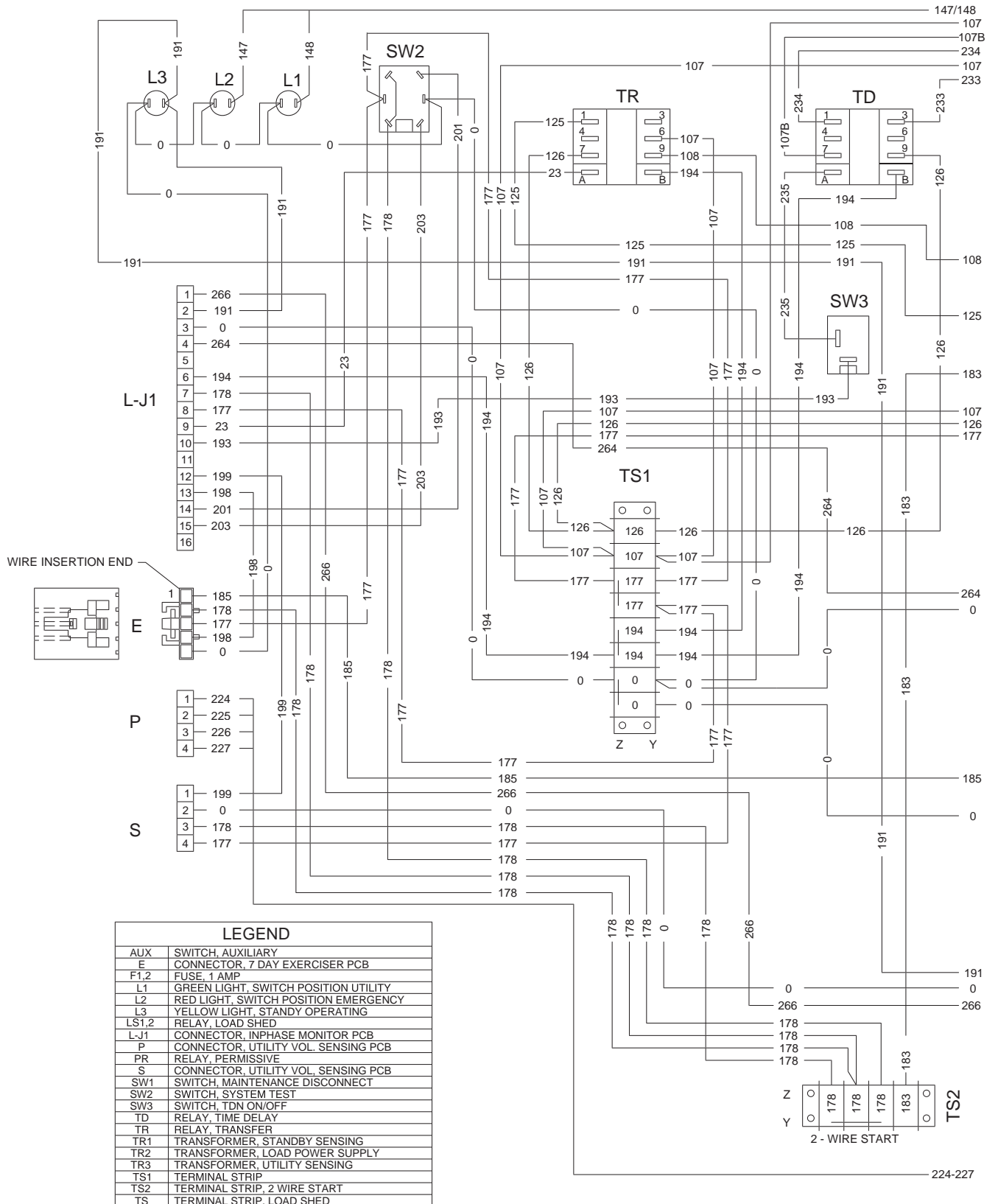

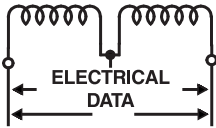

Section 6 – Electrical Schematics and Wiring Diagrams

Generac GTS "Wn" Type Transfer Switch

Electrical Schematic - 480/600V - Drawing No. 0E5322

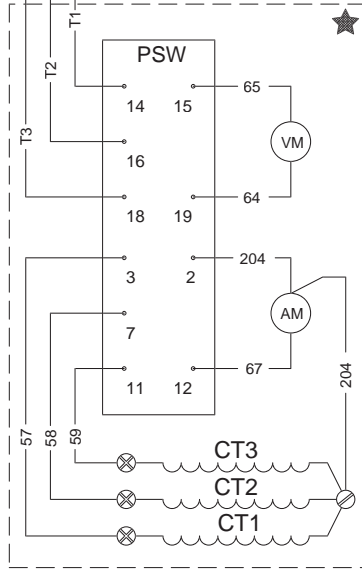
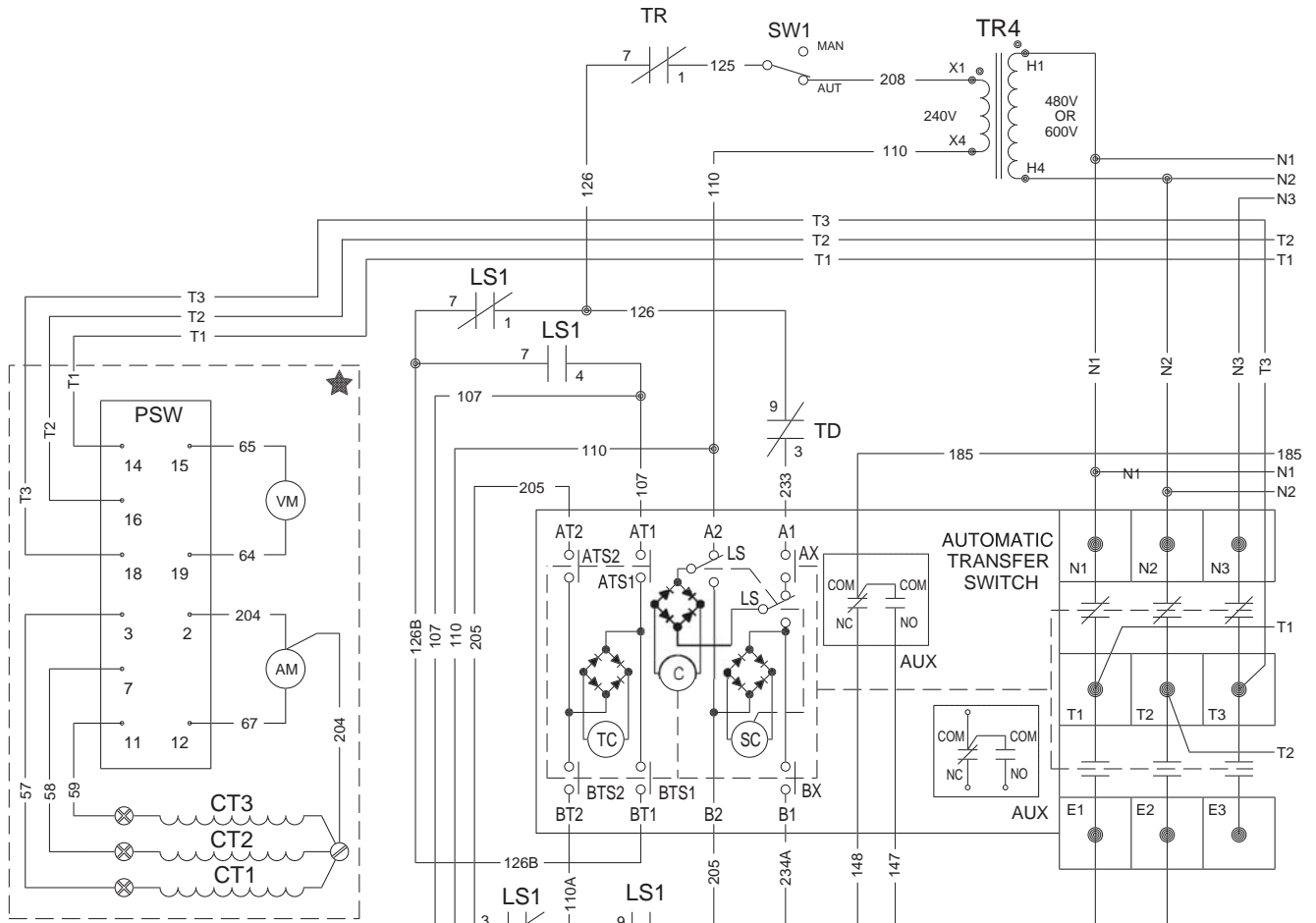

LEGEND	
A1 A2	A POWER SOURCE SIDE (ON)
AM	METER, AMP
AT1 AT2	A POWER SOURCE SIDE (TRIP)
ATS1 ATS2	SWITCH, TRIP CONTROL
BTS1 BTS2	SWITCH, TRIP CONTROL
AUX	SWITCH, AUXILIARY
Ax Bx	SWITCH, CONTROL
B1 B2	B POWER SOURCE SIDE (ON)
BT1 BT2	B POWER SOURCE SIDE (TRIP)
C	COIL, CLOSING
CT1,CT2,CT3	TRANSFORMER, CURRENT (OPT)
F1,2	FUSE, 1 AMP
FM	METER, FREQUENCY
FWB	FULLWAVE BRIDGE RECTIFIER PKG
HM	METER, HOUR
L1	GREEN LIGHT, SWITCH POSITION UTILITY
L2	RED LIGHT, SWITCH POSITION EMERGENCY
L3	YELLOW LIGHT, STANDBY OPERATING
LS	SWITCH, SELECTIVE
LS1,2	RELAY, LOAD SHED
PR	RELAY, PERMISSIVE
PSW	SWITCH, PHASE SELECTOR
SC	COIL, SELECTIVE
SW1	SWITCH, MAINTENANCE DISCONNECT
SW2	SWITCH, SYSTEM TEST
SW3	SWITCH, TDN ON/OFF
SW4	SWITCH, RETURN TO NORMAL BYPASS (OPT)
TC	COIL, TRIP
TD	RELAY, TIME DELAY
TR	RELAY, TRANSFER
TR1	TRANSFORMER, STANDBY SENSING
TR2	TRANSFORMER, LOAD POWER SUPPLY
TR3	TRANSFORMER, UTILITY SENSING
VM	METER, VOLT

PSW CONTACTS	POSITION			
	1	2	3	OFF
2 - 3		X	X	X
2 - 7	X		X	X
2 - 11	X	X		X
12 - 3	X			
12 - 7		X		
12 - 11			X	
15 - 14	X			
15 - 18		X	X	
19 - 16	X	X		
19 - 14			X	

X INDICATES CLOSED

OPTIONS

- ★ INSTRUMENT PACKAGE
- REMOTE AUTO START
- * RETURN TO NORMAL BYPASS

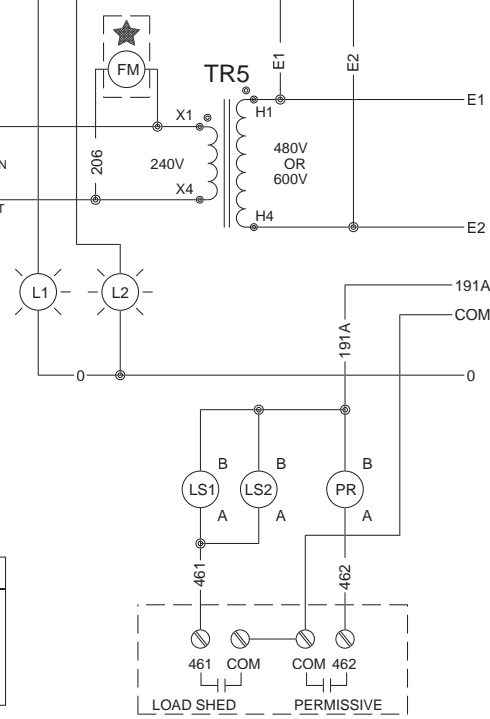

Section 6 – Electrical Schematics and Wiring Diagrams

Generac GTS "Wn" Type Transfer Switch

Electrical Schematic - 480/600V - Drawing No. 0E5322

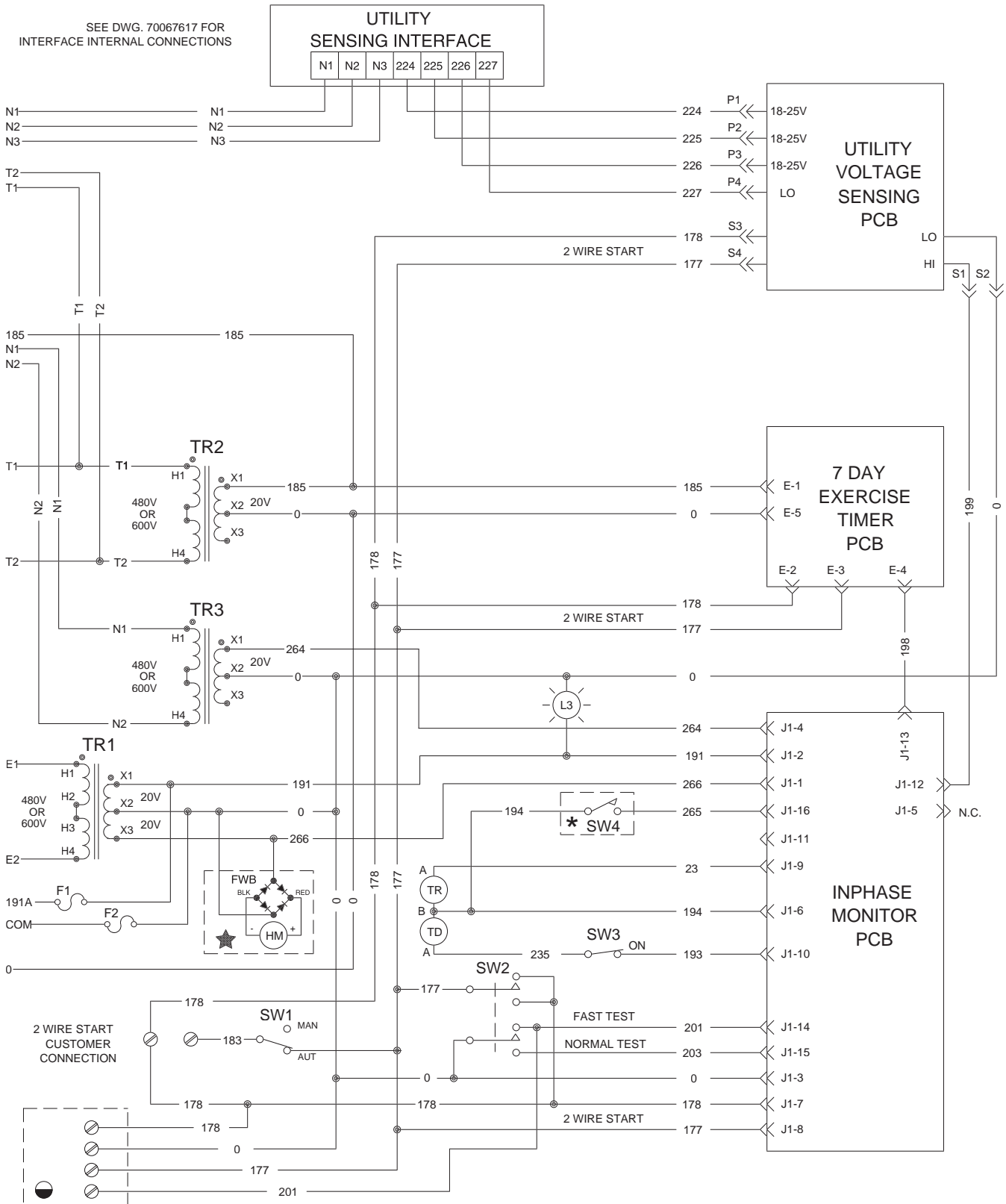
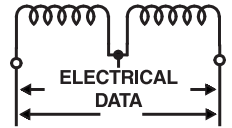

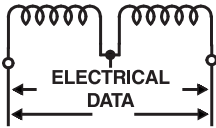

Section 6 – Electrical Schematics and Wiring Diagrams

Generac GTS "Wn" Type Transfer Switch

Wiring Diagram - 480/600V - Drawing No. 0E5318

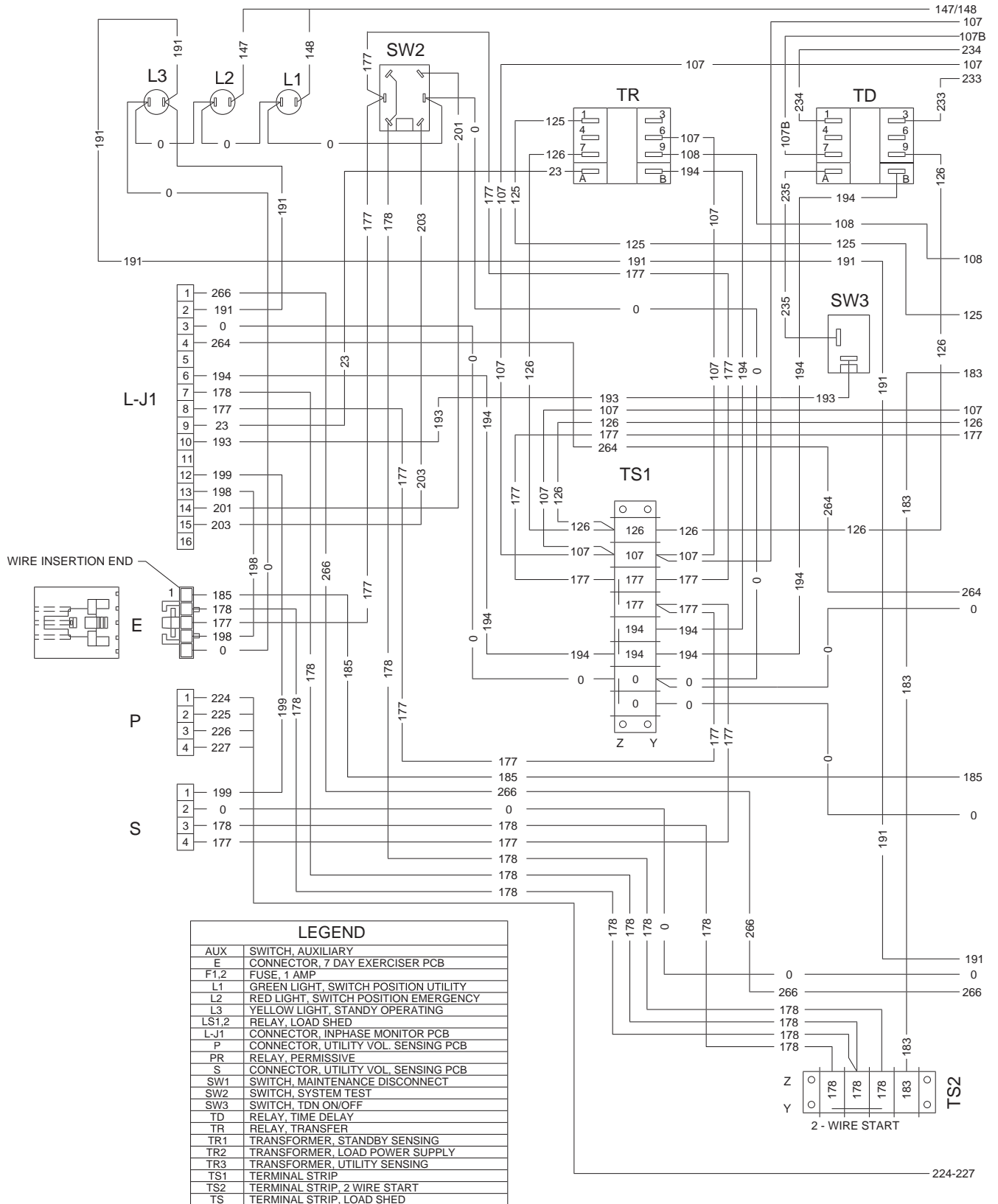

Section 6 – Electrical Schematics and Wiring Diagrams

Generac GTS "Wn" Type Transfer Switch

Wiring Diagram - 480/600V - Drawing No. 0E5318

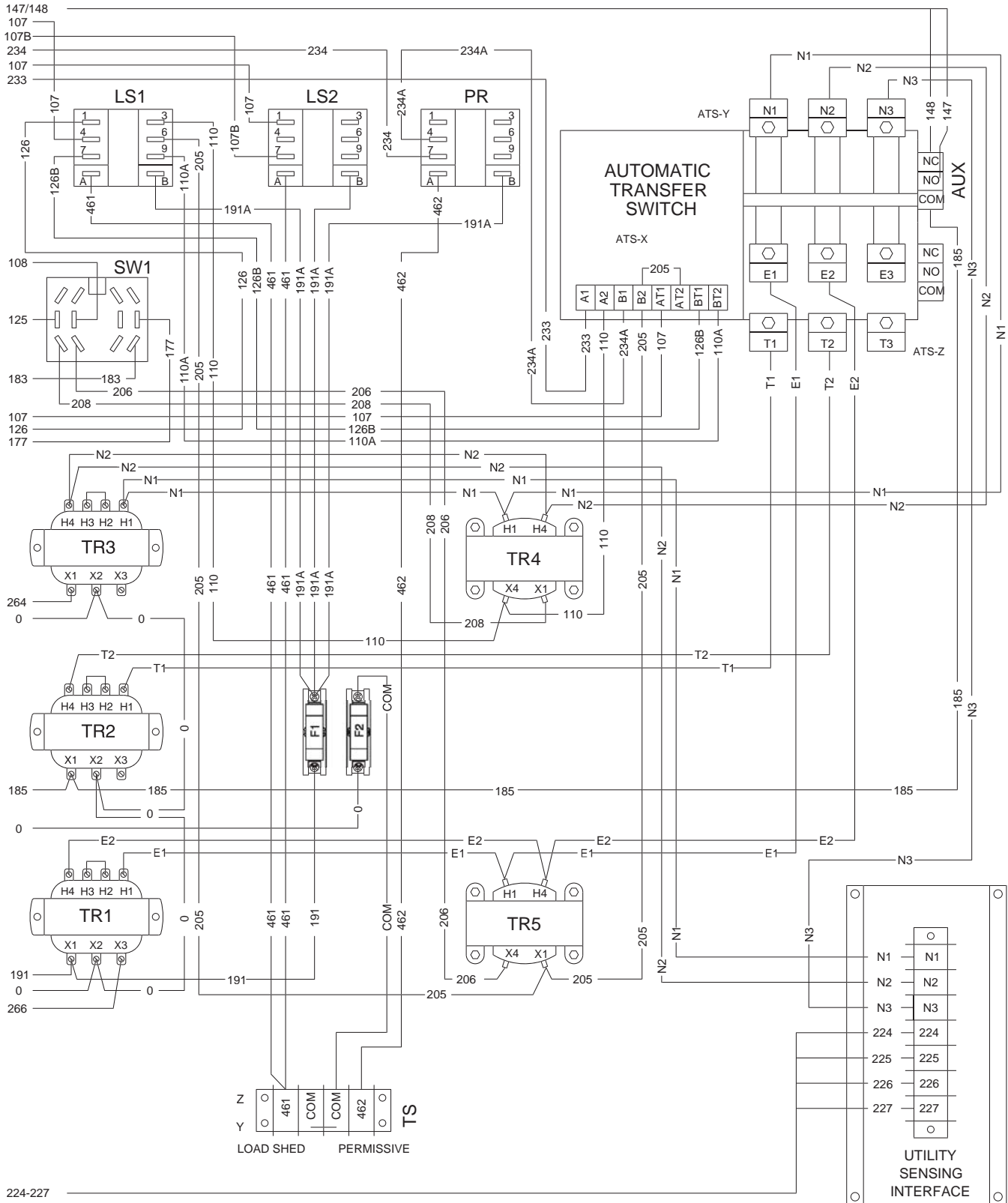
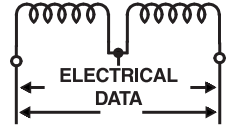

224-227

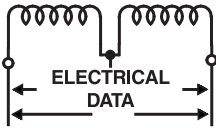

Section 6 – Electrical Schematics and Wiring Diagrams

Generac GTS “Wn” Type Transfer Switch

Wiring Diagram - Options - Drawing No. 0E5644

57,58
59,204,
T3

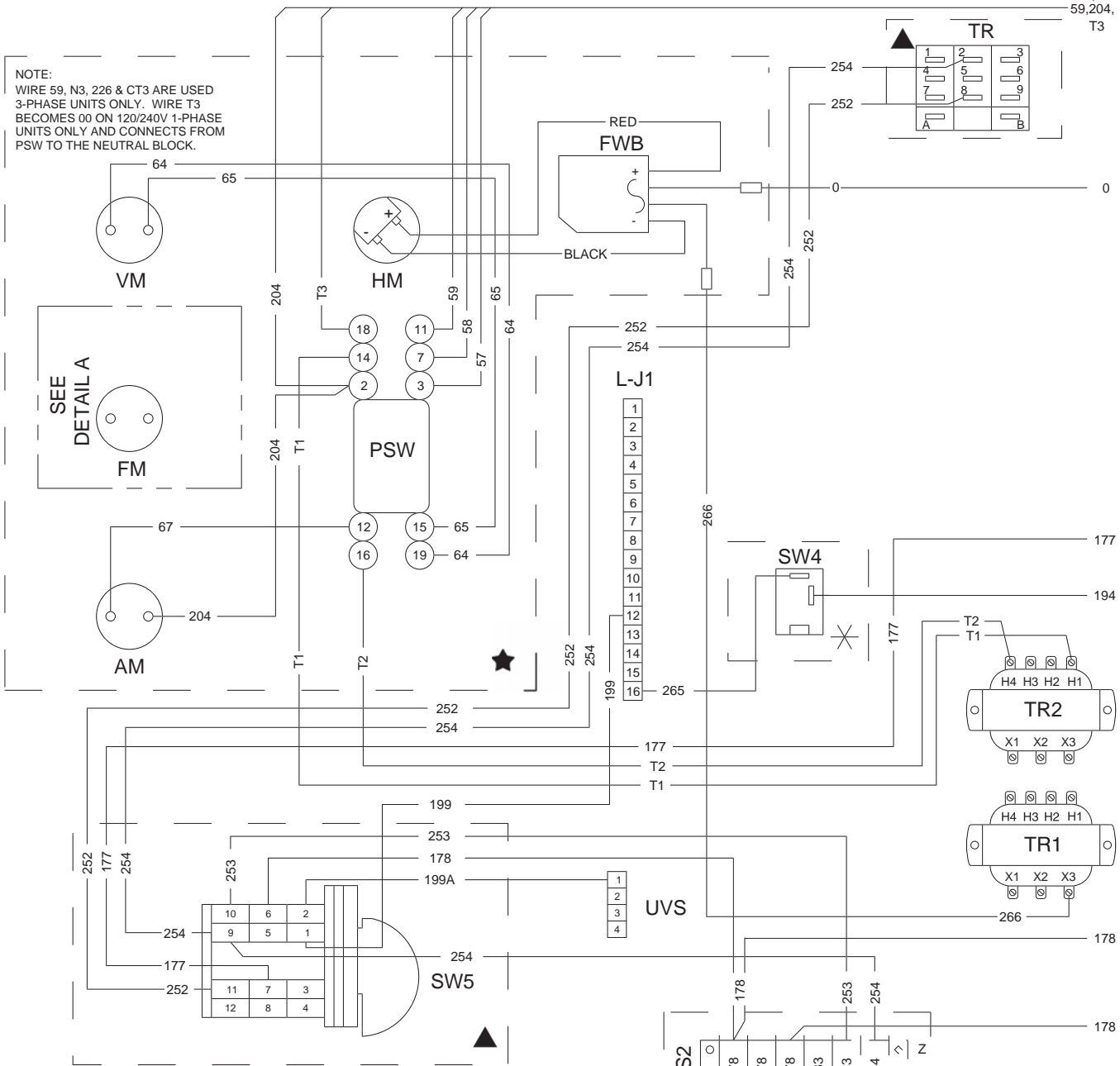

NOTE:
WIRE 59, N3, 226 & CT3 ARE USED
3-PHASE UNITS ONLY. WIRE T3
BECOMES 00 ON 120/240V 1-PHASE
UNITS ONLY AND CONNECTS FROM
PSW TO THE NEUTRAL BLOCK.

SEE
DETAIL A

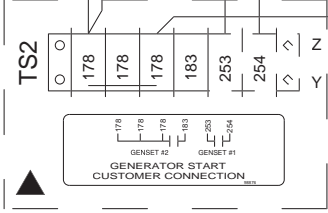
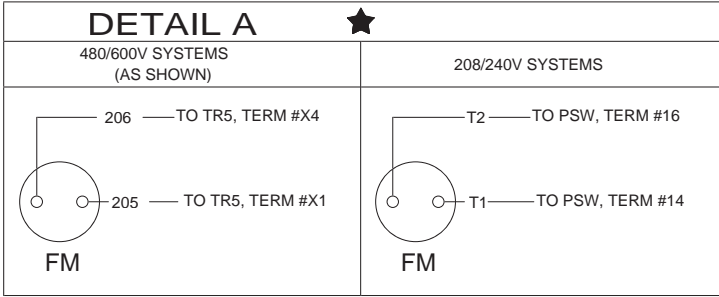

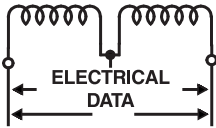

Section 6 – Electrical Schematics and Wiring Diagrams

Generac GTS "Wn" Type Transfer Switch

Electrical Schematic - 208/240V - Drawing No. 0E5323

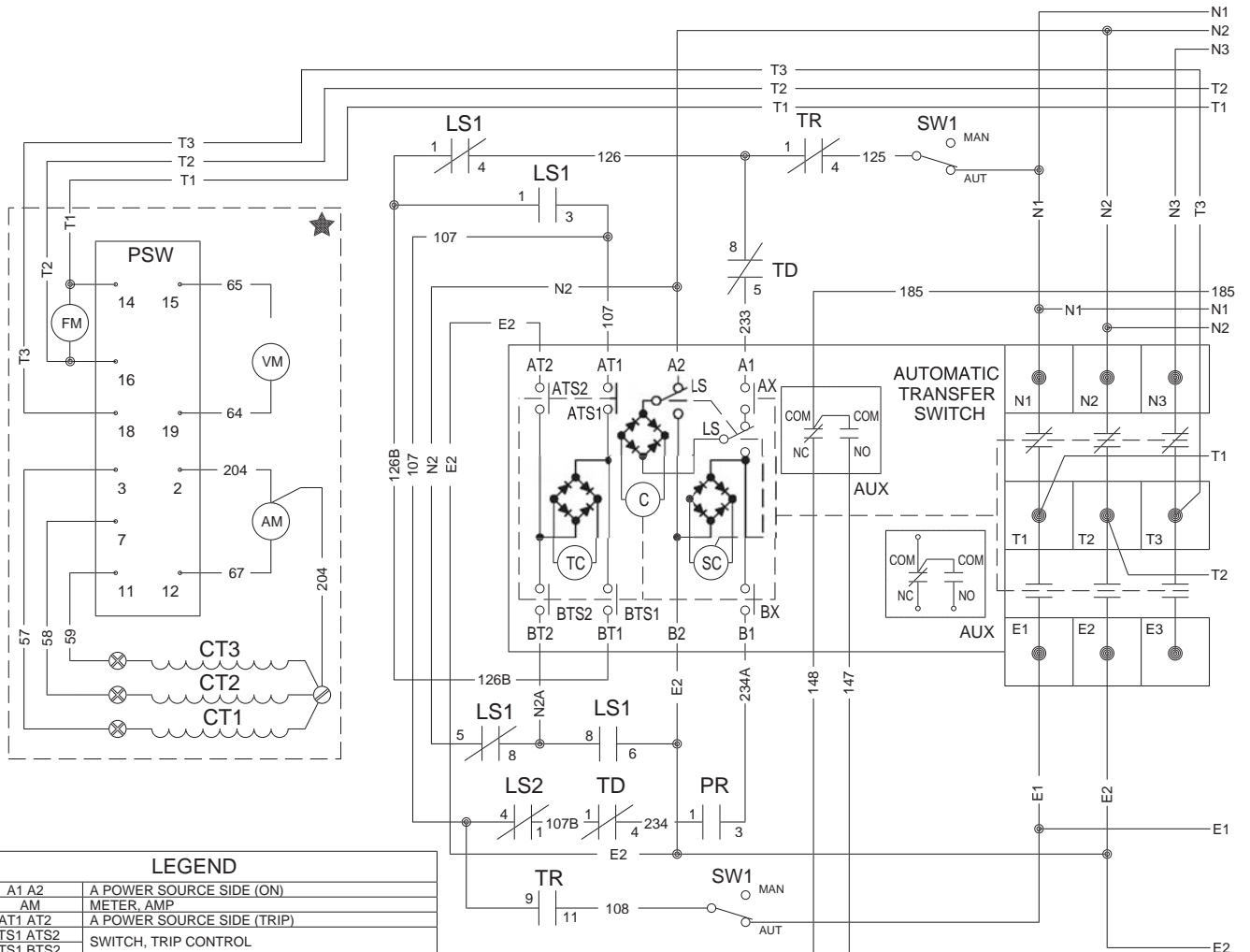

LEGEND	
A1 A2	A POWER SOURCE SIDE (ON)
AM	METER, AMP
AT1 AT2	A POWER SOURCE SIDE (TRIP)
ATS1 ATS2	SWITCH, TRIP CONTROL
BTS1 BTS2	SWITCH, TRIP CONTROL
AUX	SWITCH, AUXILIARY
Ax Bx	SWITCH, CONTROL
B1 B2	B POWER SOURCE SIDE (ON)
BT1 BT2	B POWER SOURCE SIDE (TRIP)
C	COIL, CLOSING
CT1,CT2,CT3	TRANSFORMER, CURRENT (OPT)
F1,2	FUSE, 1 AMP
FM	METER, FREQUENCY
FWB	FULL WAVE BRIDGE RECTIFIER PKG
HM	METER, HOUR
L1	GREEN LIGHT, SWITCH POSITION UTILITY
L2	RED LIGHT, SWITCH POSITION EMERGENCY
L3	YELLOW LIGHT, STANDBY OPERATING
LS	SWITCH, SELECTIVE
LS1,2	RELAY, LOAD SHED
PR	RELAY, PERMISSIVE
PSW	SWITCH, PHASE SELECTOR
SC	COIL, SELECTIVE
SW1	SWITCH, MAINTENANCE DISCONNECT
SW2	SWITCH, SYSTEM TEST
SW3	SWITCH, TDN ON/OFF
SW4	SWITCH, RETURN TO NORMAL BYPASS (OPT)
TC	COIL, TRIP
TD	RELAY, TIME DELAY
TR	RELAY, TRANSFER
TR1	TRANSFORMER, STANDBY SENSING
TR2	TRANSFORMER, LOAD POWER SUPPLY
TR3	TRANSFORMER, UTILITY SENSING
VM	METER, VOLT

PSW CONTACTS	POSITION			
	1	2	3	OFF
2 - 3		X	X	X
2 - 7		X	X	X
2 - 11		X	X	X
12 - 3	X			
12 - 7		X		
12 - 11			X	
15 - 14	X			
15 - 18		X	X	
19 - 16	X	X		
19 - 14			X	

X INDICATES CLOSED

OPTIONS	
★	INSTRUMENT PACKAGE
●	REMOTE AUTO START
*	RETURN TO NORMAL BYPASS

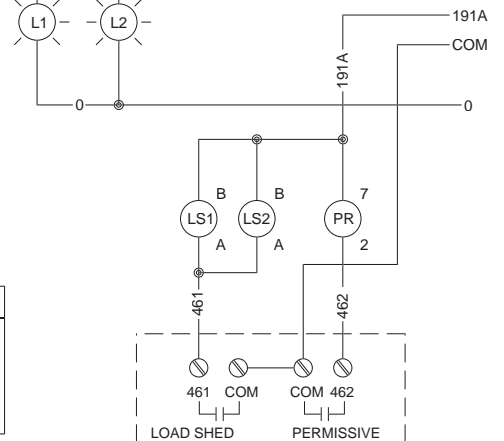

Section 6 – Electrical Schematics and Wiring Diagrams

Generac GTS "Wn" Type Transfer Switch

Electrical Schematic - 208/240V - Drawing No. 0E5323

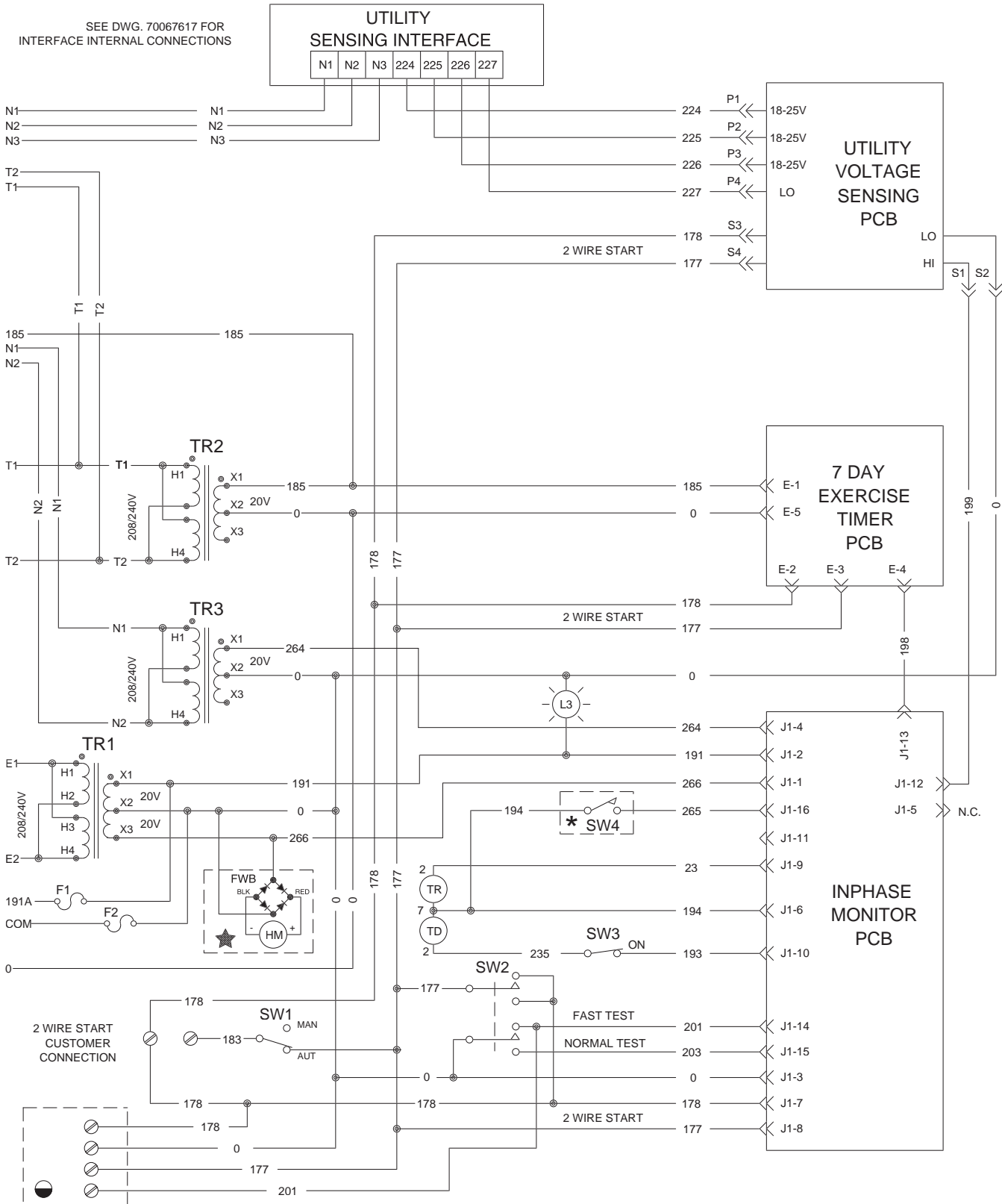
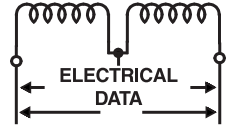

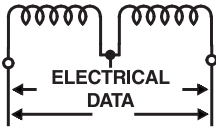

Section 6 – Electrical Schematics and Wiring Diagrams

Generac GTS "Wn" Type Transfer Switch

Wiring Diagram - 208/240V - Drawing No. 0E5319

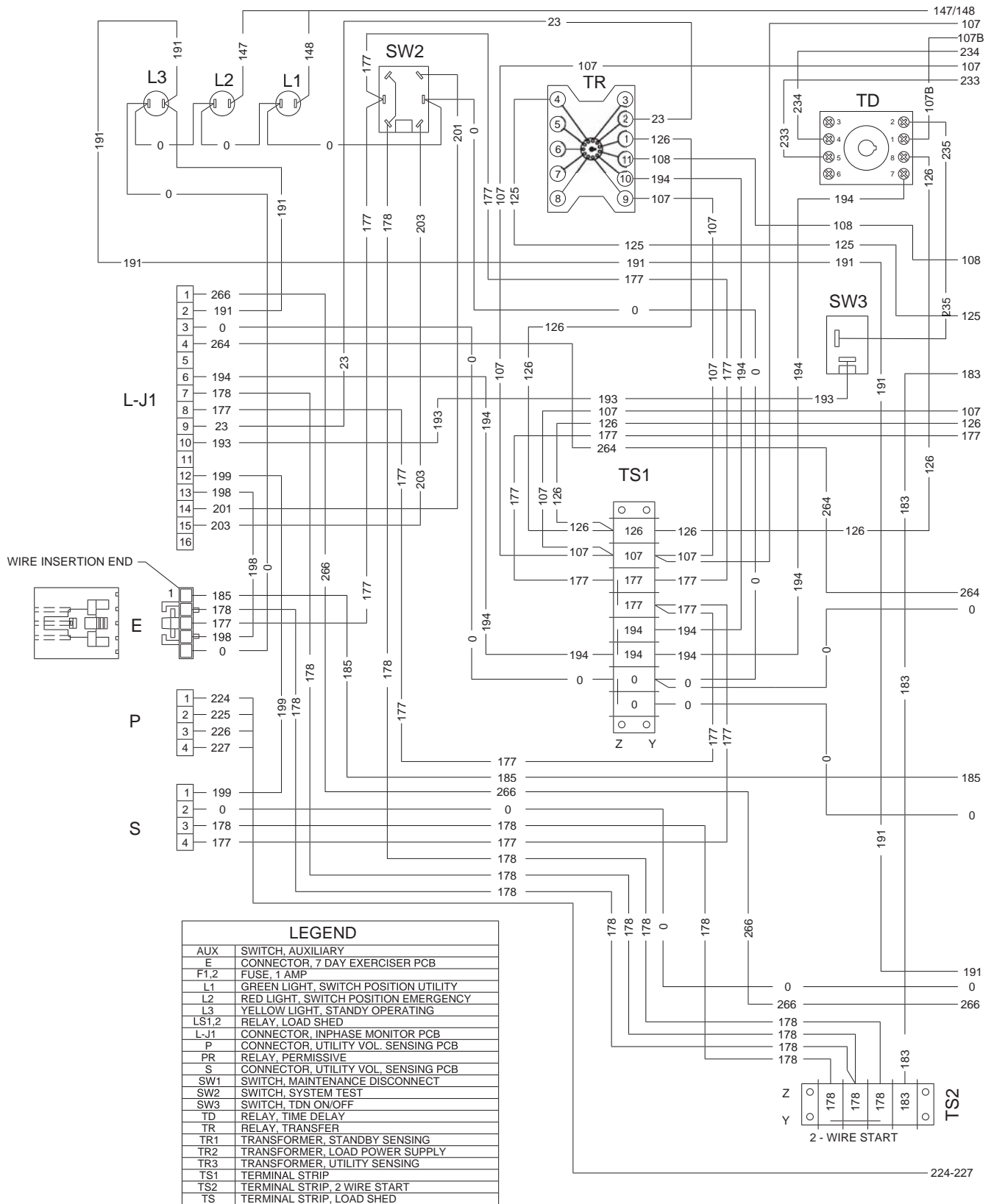

Section 6 – Electrical Schematics and Wiring Diagrams

Generac GTS "Wn" Type Transfer Switch

Wiring Diagram - 208/240V - Drawing No. 0E5319

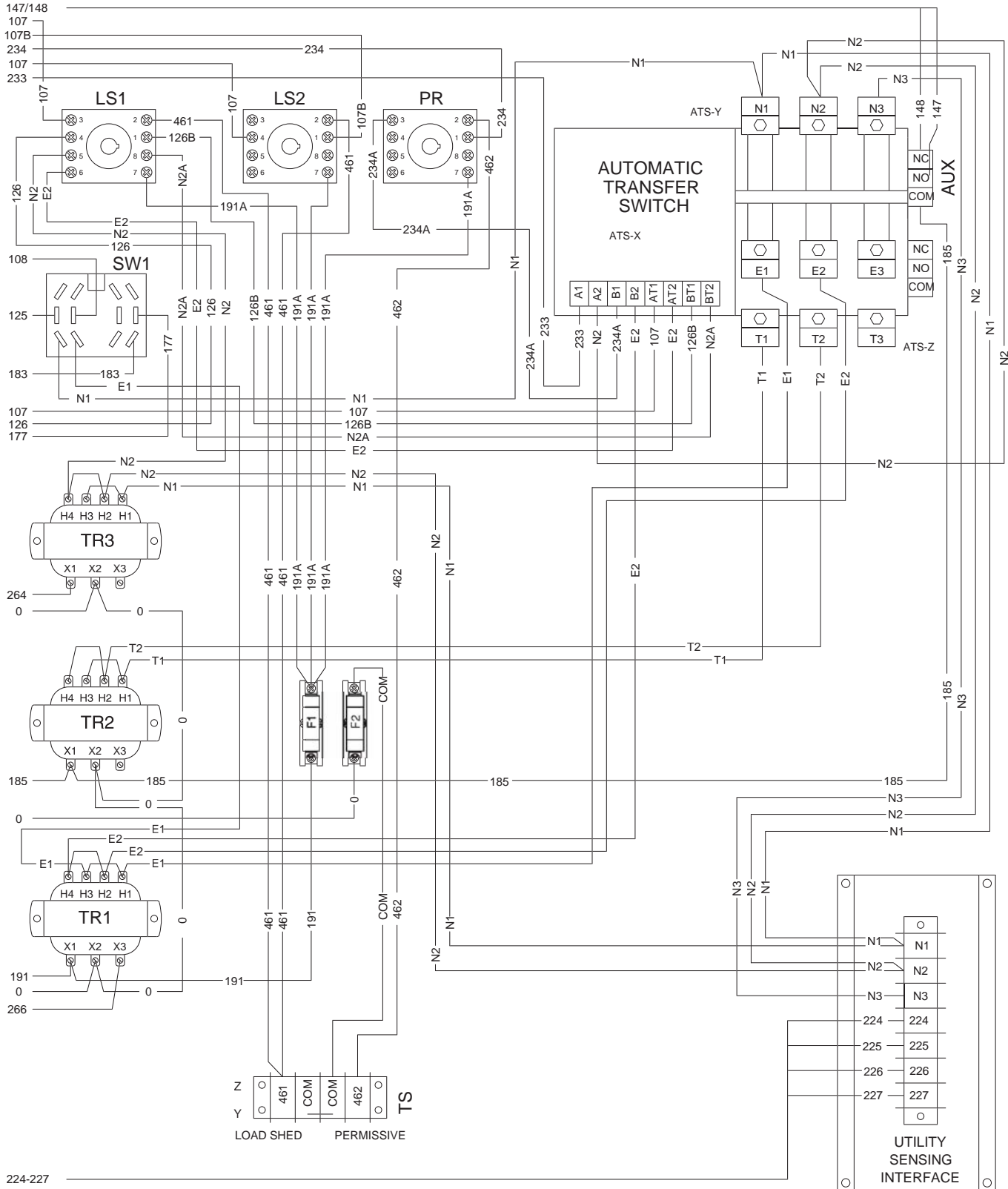
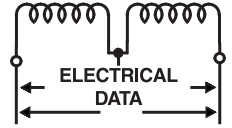

224-227

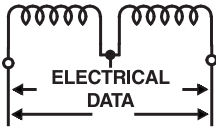

Section 6 – Electrical Schematics and Wiring Diagrams

Generac GTS "Wn" Type Transfer Switch

Electrical Schematic - 480/600V - Drawing No. 0E5324

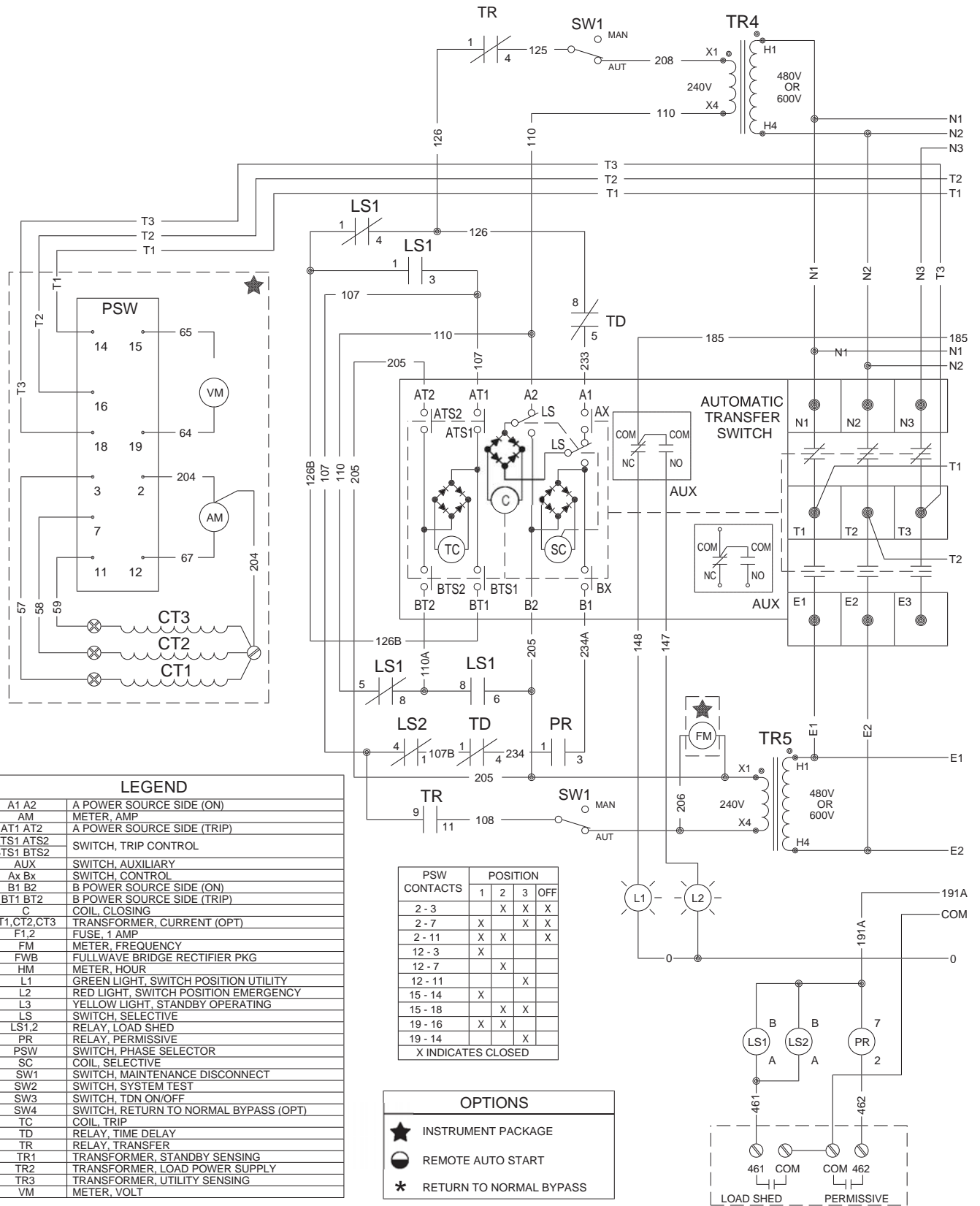

LEGEND	
A1 A2	A POWER SOURCE SIDE (ON)
AM	METER, AMP
AT1 AT2	A POWER SOURCE SIDE (TRIP)
ATS1 ATS2	SWITCH, TRIP CONTROL
BTS1 BTS2	SWITCH, TRIP CONTROL
AUX	SWITCH, AUXILIARY
Ax Bx	SWITCH, CONTROL
B1 B2	B POWER SOURCE SIDE (ON)
BT1 BT2	B POWER SOURCE SIDE (TRIP)
C	COIL, CLOSING
CT1, CT2, CT3	TRANSFORMER, CURRENT (OPT)
F1, 2	FUSE, 1 AMP
FM	METER, FREQUENCY
FWB	FULLWAVE BRIDGE RECTIFIER PKG
HM	METER, HOUR
L1	GREEN LIGHT, SWITCH POSITION UTILITY
L2	RED LIGHT, SWITCH POSITION EMERGENCY
L3	YELLOW LIGHT, STANDBY OPERATING
LS	SWITCH, SELECTIVE
LS1, 2	RELAY, LOAD SHED
PR	RELAY, PERMISSIVE
PSW	SWITCH, PHASE SELECTOR
C	COIL, SELECTIVE
SW1	SWITCH, MAINTENANCE DISCONNECT
SW2	SWITCH, SYSTEM TEST
SW3	SWITCH, TDN ON/OFF
SW4	SWITCH, RETURN TO NORMAL BYPASS (OPT)
TC	COIL, TRIP
TD	RELAY, TIME DELAY
TR	RELAY, TRANSFER
TR1	TRANSFORMER, STANDBY SENSING
TR2	TRANSFORMER, LOAD POWER SUPPLY
TR3	TRANSFORMER, UTILITY SENSING
VM	METER, VOLT

PSW CONTACTS	POSITION			
	1	2	3	OFF
2 - 3		X	X	X
2 - 7	X		X	X
2 - 11	X	X		X
12 - 3	X			
12 - 7		X		
12 - 11			X	
15 - 14	X			
15 - 18		X	X	
19 - 16	X	X		
19 - 14			X	

X INDICATES CLOSED

OPTIONS	
★	INSTRUMENT PACKAGE
●	REMOTE AUTO START
*	RETURN TO NORMAL BYPASS

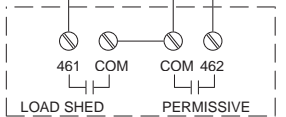

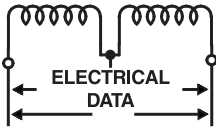

Section 6 – Electrical Schematics and Wiring Diagrams

Generac GTS "Wn" Type Transfer Switch

Wiring Diagram - 480/600V - Drawing No. 0E5320

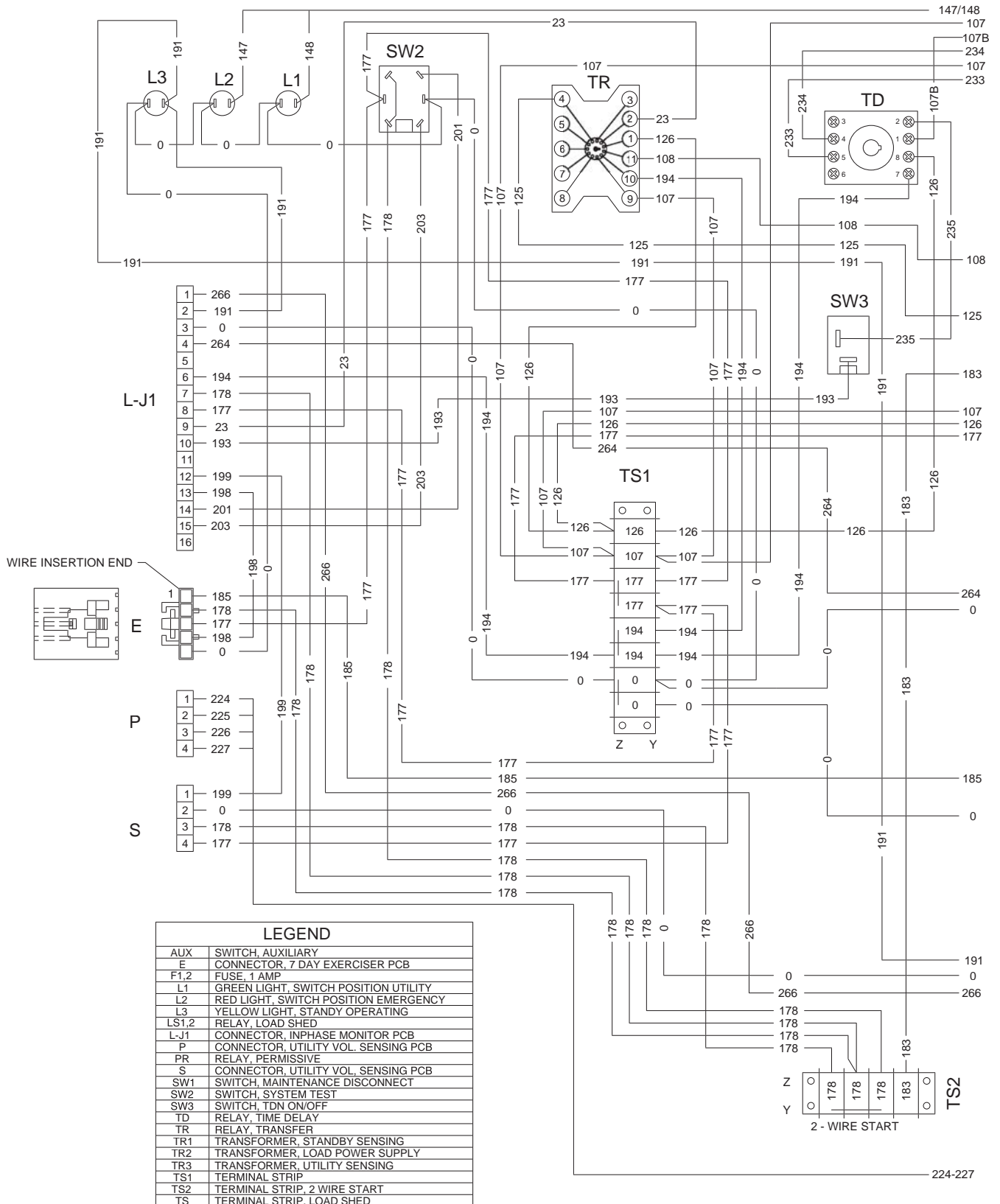

Section 6 – Electrical Schematics and Wiring Diagrams

Generac GTS "Wn" Type Transfer Switch

Wiring Diagram - 480/600V - Drawing No. 0E5320

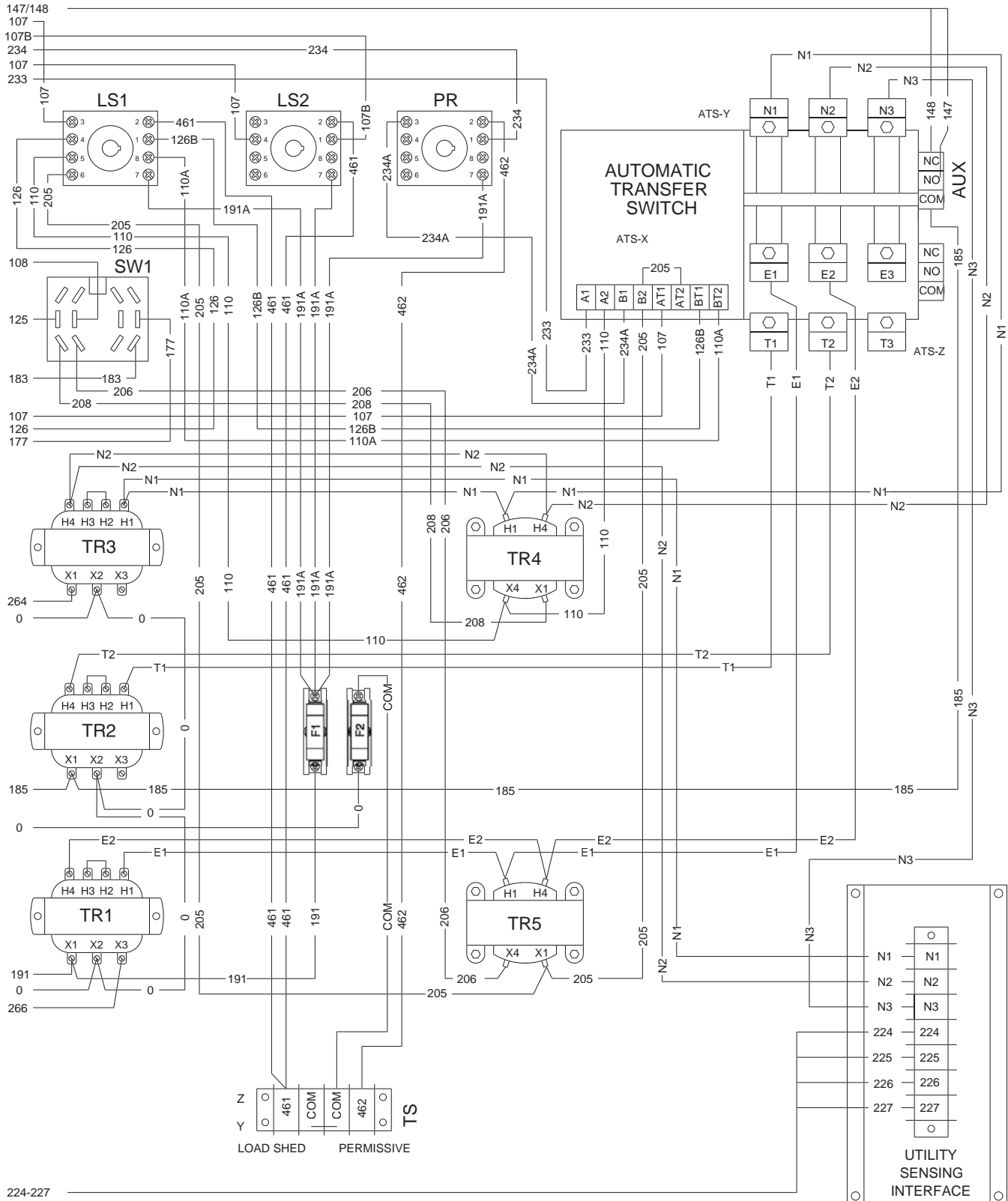
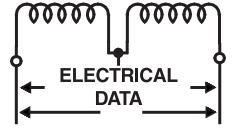

224-227

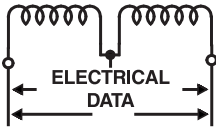

Section 6 – Electrical Schematics and Wiring Diagrams

Generac GTS "Wn" Type Transfer Switch

Wiring Diagram - Options - Drawing No. 0D8644-A

NOTE:
WIRE 59, N3, 226 & CT3 ARE USED
3-PHASE UNITS ONLY. WIRE T3
BECOMES 00 ON 120/240V 1-PHASE
UNITS ONLY AND CONNECTS FROM
PSW TO THE NEUTRAL BLOCK.

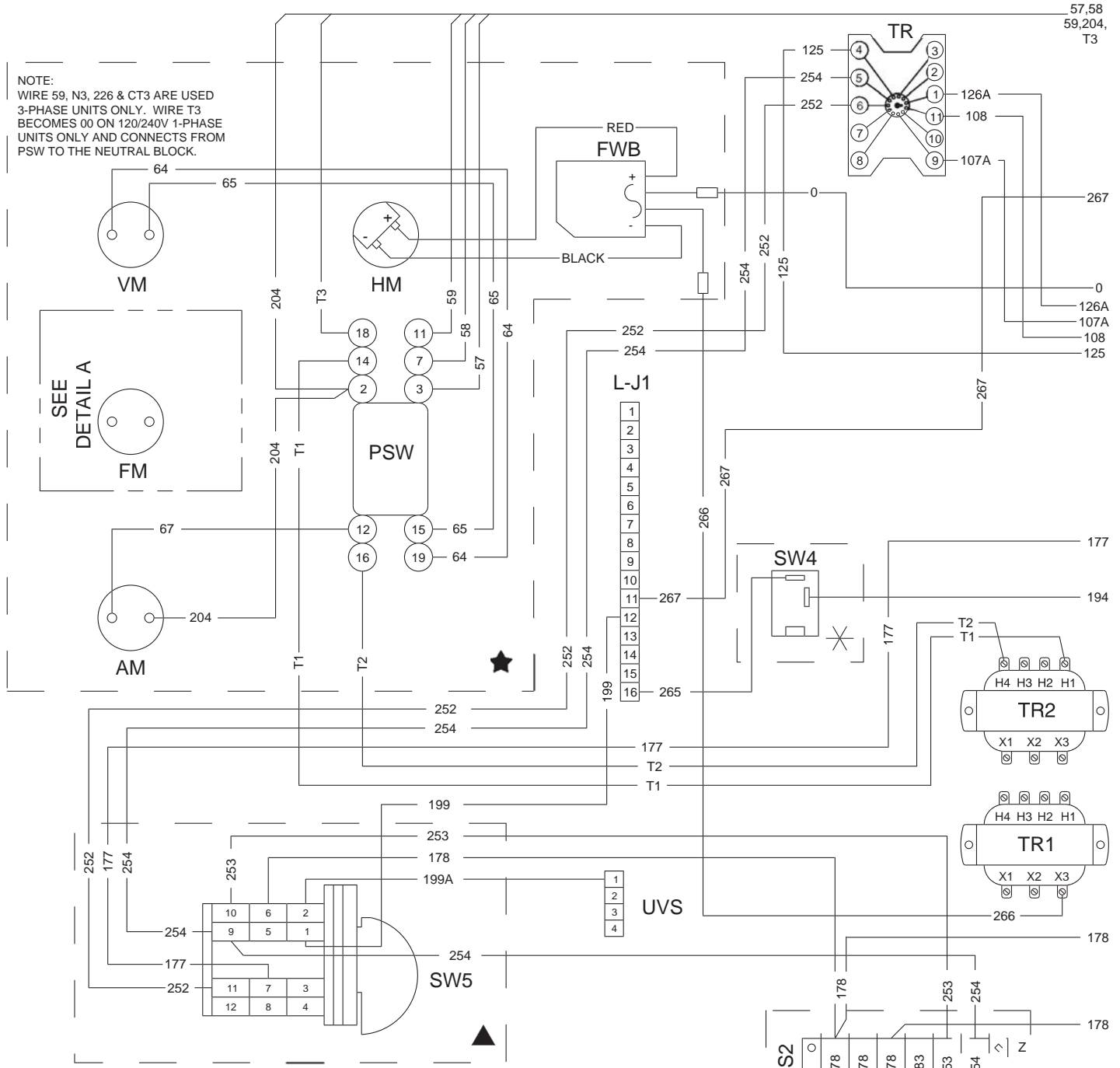

57,58
59,204,
T3

DETAIL A

480/600V SYSTEMS (AS SHOWN)	416V SYSTEMS (3 & 4-POLE)	208/240V SYSTEMS

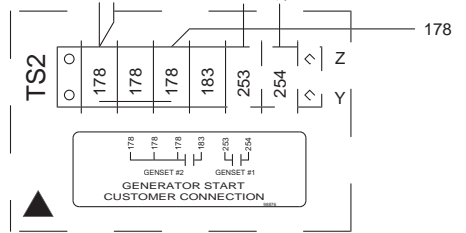

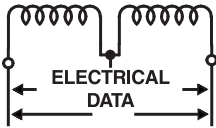

Section 6 – Electrical Schematics and Wiring Diagrams

Generac GTS "Wn" Type Transfer Switch

Connection Diagram - Drawing No. 073658

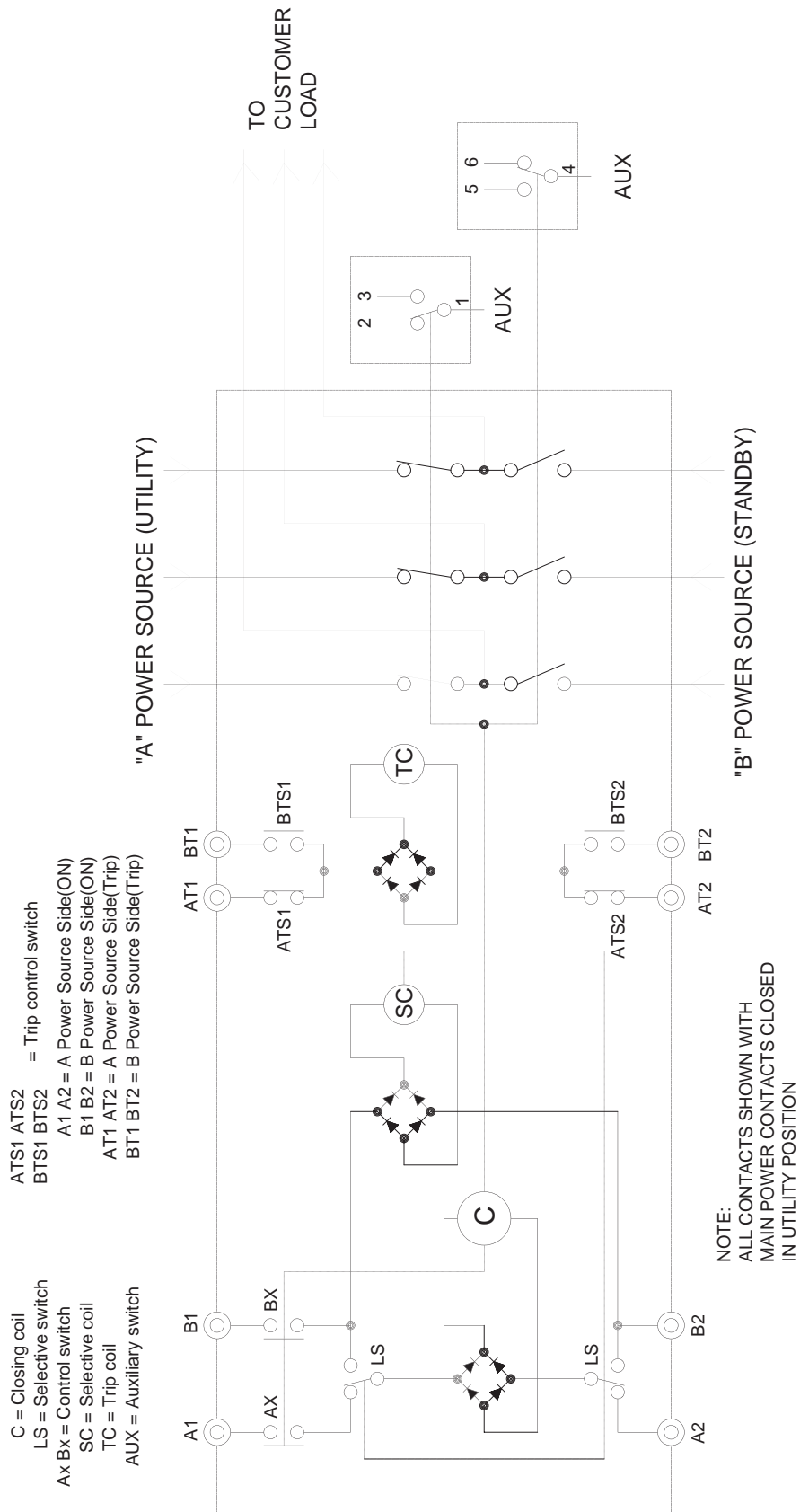

Section 6 – Electrical Schematics and Wiring Diagrams

Generac GTS "Wn" Type Transfer Switch

Electrical Schematic/Interface - Drawing No. 70067617-B

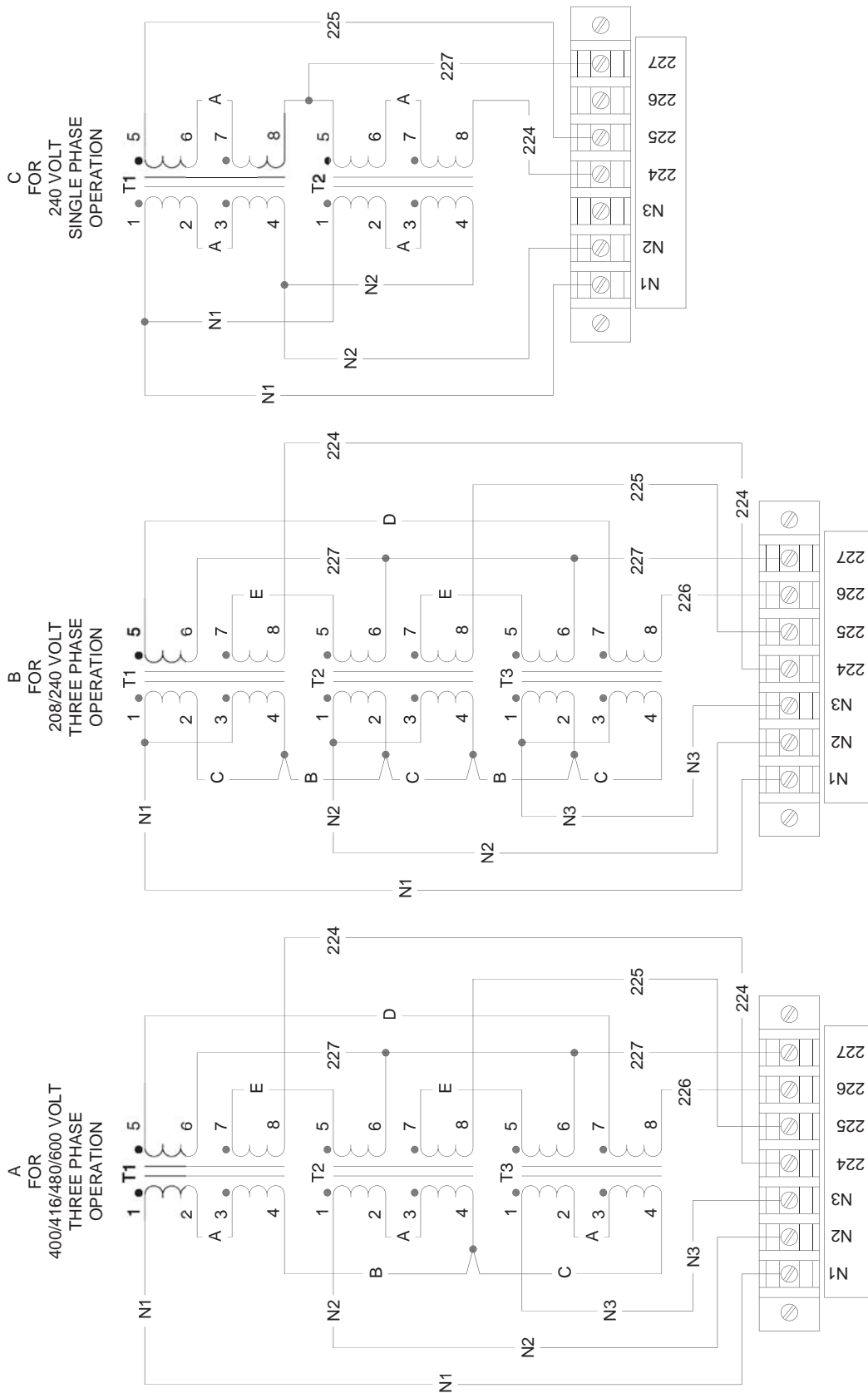
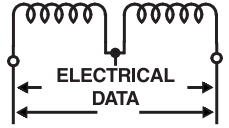

Section 7 – Exploded Views & Parts Lists

Generac GTS "Wn" Type Transfer Switch

100A Assembly - Drawing No. 0E7363\$ Part 1

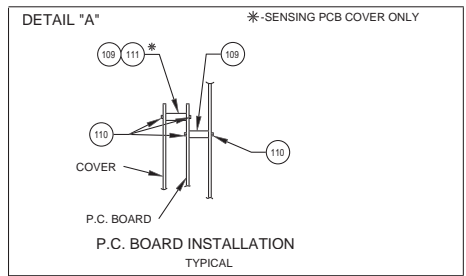
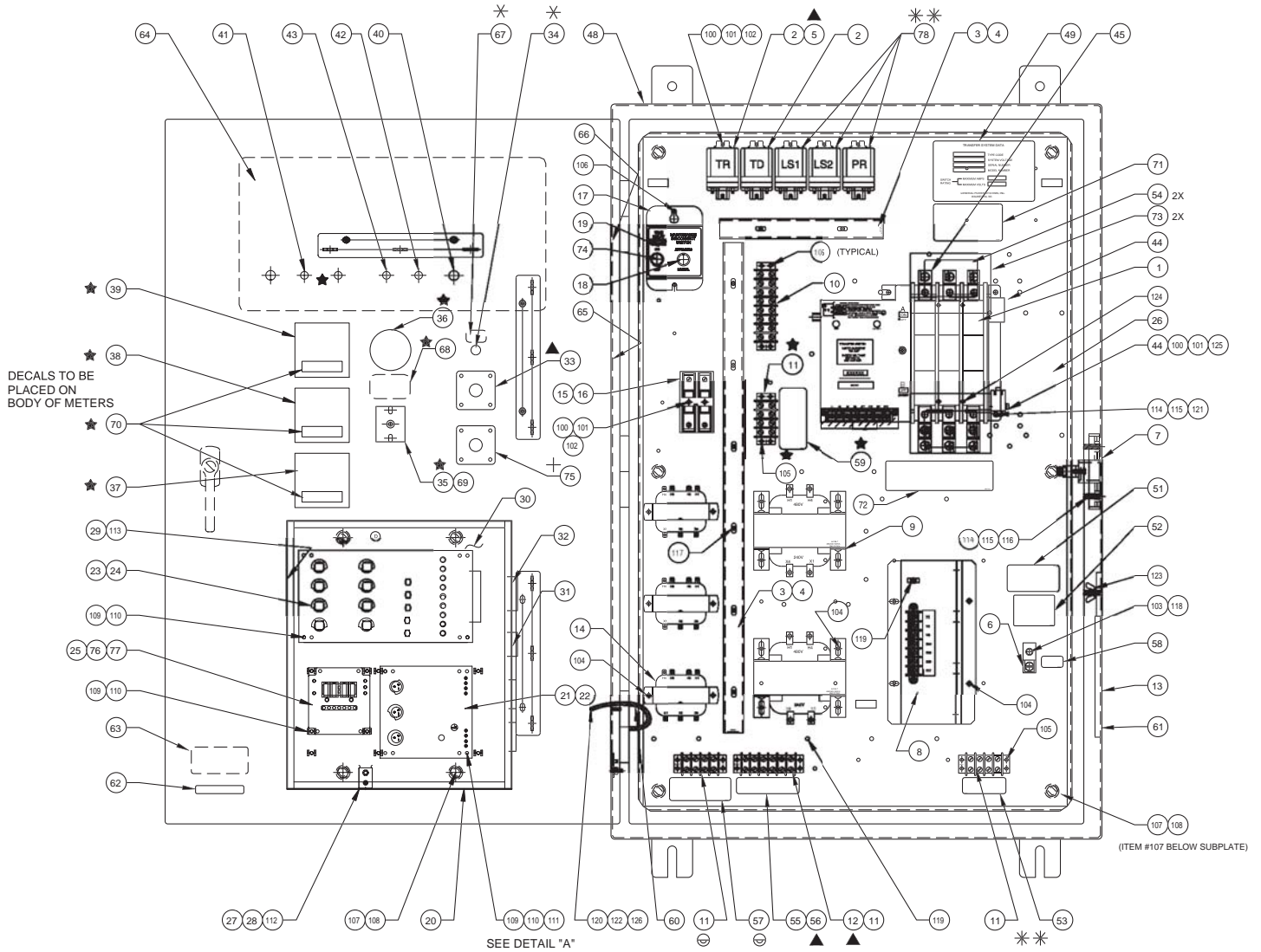

- LEGEND**
- ★ - INSTRUMENT PACKAGE
 - * - RETURN TO NORMAL BYPASS
 - ▲ - PREFERRED SOURCE SELECTOR (USE 3-POLE RELAY AND 6-POLE TERMINAL STRIP)
 - ⊖ - REMOTE AUTO CONTROL
 - ⊕ - AUTO/NORMAL/STANDBY SELECTOR
 - * - TRIP TO NEUTRAL

Section 7 — Exploded Views & Parts Lists

Generac GTS "Wn" Type Transfer Switch

100A Assembly - Drawing No. 0E7363\$ Part 1

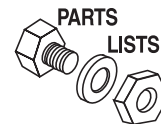

ITEM	PART NO.	QTY.	DESCRIPTION	ITEM	PART NO.	QTY.	DESCRIPTION
1	064787	1	XFRSW 100A 3P WN600V		0C3472B	1	ENCL-NEM4X 1-150A
	064788	1	XFRSW 100A 4P WN600V	49	063578	1	PLATE DATA - OEM
2	063617	REF	RELAY PNL 12VDC DPDT 10A@240VA		0E5495	1	DECAL DATA PRIVATE LABEL
3	091472A	REF	COVER WIRE DUCT 1 IN	50	064153A	REF	WIRE-XFMR JUMPER (NOT SHOWN)
4	091472	REF	DUCT WIRING 1X1.5 6 FT	51	083736	1	DECAL-CSA GTS (OPTIONAL)
5▲	057334	REF	RELAY PNL 12VDC 3PDT 10A FL MT	52	062209	1	DECAL UL LABEL E84929-GTS
6	062684	1	LUG SLDLSS 2/0-#12 X 11/32 CU	53**	0E5548	1	DECAL LOAD-SHED-PERMISSIVE
7	0C4449	1	ASSY NEUTRAL BLOCK 100A	54	0C8308	2	DECAL TERMINAL SHOCK HAZARD
8	072158	1	INTRFC,3PHS 600V	55	091466	1	DECAL 2 WR TERM STRP
	072160	1	INTRFC,3P 400V 50/60	56▲	098876	1	DECAL, DUAL START
	067617030A	1	INTRFC,3PHS 416/480V	57●	074571	1	DECAL-REM. AUTO CNTR
	067617030B	1	INTRFC,3PHS 208/240V	58	067210A	1	DECAL GROUND LUG
	086961	1	INTRFC,1PH 240V	59★	064114	1	DECAL-CUST CONN CTS
9	072162	2	TRANSFRM 600V TO 240V 200VA	60	0536210193	1	GND WIRE-ENCLSR DOOR
	064126	2	TRANSFRM 240/480V-120/240V	61	0D4545	1	DECAL, MANUAL OPERATION
10	057701	1	BLOCK TERM 20A 8 X 6 X 1100V	62	077228	1	DECAL-ENCLOSURE NOTE
11★**●	046689	REF	BLOCK TERM 20A 4 X 6 X 1100V	63	095282	1	DECAL-LIVE CIRCUIT
12▲	046357	REF	BLOCK TERM 20A 6 X 6 X 1100V	64	0C2864	1	ENC DEC-OEM XFER SW
13	063321	1	HANDLE XFER SWITCH 1-400A		0C8135	1	DECAL-OEM DR-IN-DR
14	090975	3	XFMR 240/40V 25VA (480V & UNDER)		0E5374	1	DECAL-ENCLOSURE PRIVATE LABEL
	095394	3	XFRMR 600/40V 25VA (600V ONLY)		0E5371	1	DECAL-DOOR IN DOOR PRIVATE LABEL
15	073590C	2	FUSE,BBS 1A 600V	65	063385A	1	SWITCH INFO DECAL
16	0D2806	1	FUSEBLOCK 30A 600V 2POS W/SQ	66	073619B	1	DECAL-TEST SEQ 100WN
17	074509	1	BRACKET SWITCH		095089H	1	DECAL 600V/100A W/WN
18	055868	1	SWITCH TOGGLE 4PDT 15A SPADE	67*	075369	1	DECAL-RET NML BYPASS
19	074511	1	DECAL TDN MAINTENANCE SW	68★	0C2603	1	DECAL PH SELECT A/V
20	0C1652	1	ENCLOSURE-PCB, NEW	69★	0E1301	1	AUX CONT INSULATOR
21	067616020A	1	ASSY-STNDSNS CVRPLT	70★	0C4895	4	DECAL SHOCK HAZARD
22	067629	1	ASSY STANDARD SENSNG	71	054199	1	DECAL HIGH VOLTAGE
23	092734	1	ASSY INPHASE MONITOR	72	064510	1	DECAL-TERMINAL NOTE
24	094200A	1	ASSY-INPH COVR PLAT	73	0C7907B	2	COVER LUG 3P 100AMP
25	0A8637	1	ASSY MK3 EXERCISER W/COVER		0C7907C	2	COVER LUG 4P 100AMP
	064217	1	ASSY 7-DAY EXERCISER (NOT SHOWN)	74	028199	1	SWITCH TOGGLE SPST 6A TAB C-H
26	0C3593	1	SBPL100A W/Y/C-XFRSW	75	074614	1	SW 3 POS NRM/ATO/STB
27	063982	1	CLIP BATT-9V TRANSIS	76	0E2651	1	CABLE, DLX-STD INTERFACE (NOT SHOWN)
28	063998	1	BATTERY 9V	77	063996	1	ASSY, COVER STANDARD EXERCISER (NOT SHOWN)
29	0C1720	1	SD GUIDE-NEW PCB ENC				
30	0C1721	1	DOOR, NEW PCB ENC	78	0E5820	3	RELAY PNL 24VAC DPDT 10A FL MT
31	038057	1	GROMMET 7/8 X 1/16 X 3/4	100	038150	REF	WASHER FLAT #8 ZINC
32	072252	1	GROMMET 1.37 X .06 X 1.00	101	022264	REF	WASHER LOCK #8-M4
33▲	074613	1	SW 2POS SOURCE SELCT	102	0A2284	REF	SCREW SWAGE 8-32 X 1/2 Z/YC
34*	072827	1	SWITCH TOG SPST 6A@125V SP MOM	103	024526	1	SCREW HHTT 5/16-18 X 3/4 CZ
35★	061945	1	SWITCH SELECTOR 6A AMP/V	104	056893	REF	SCREW CRIMPTITE 10-24 X 1/2
36★	070081	1	HOURMETER	105	0A1661	REF	RIVET POP .156 X .675 AL
37★	070045	1	AMMETER AC 0-200	106	0A2111	4	SCREW SWAGE 10-32 X 5/16 Z/YC
38★	070042	1	FREQUENCY METER 240V 55-65HZ	107	022131	10	WASHER FLAT 3/8-M10 ZINC
39★	070043	1	VOLTMETER AC 0-300	108	064101	10	NUT LOCK FL 3/8-16
★	070044	1	VOLTMETER AC 0-600	109	064525	16	STANDOFF HEX 3/4
40	055142	1	SWITCH TOG DPDT 15A MOM W/SEAL	110	064526	40	SCREW S-THR PH #6-25 X 3/8 ZNC
41	0C2163C	1	LED YEL WITH HOLDER	111+	068337	4	STANDOFF-HEX 1.00 LG
42	0C2163A	1	LED GRN WITH HOLDER	112	0D7505	2	RIVET POP .094 X .250 BLND AL
43	0C2163B	1	LED RED WITH HOLDER	113	036261	4	RIVET POP .125 X .275 AL
44	074604	REF	AUX CNTCT N-TYP SPDT	114	022473	REF	WASHER FLAT 1/4-M6 ZINC
	074672A	REF	LMT SW-WN SEL&AUX2PL	115	022097	REF	WASHER LOCK M6-1/4
45	099084	REF	LUG SLDLSS 2/0-#6X21/64 AL/CU (100A)	116	022127	2	NUT HEX 1/4-20 STEEL
46★	064117	REF	TRANSFRM 200A:5A 5VA	117	091477	8	RIVET, WIRE DUCT MNT
47	0E7598A	REF	GTS 100-200A TTN WRS-STNDRD	118	027482	1	WASHER SHAKEPROOF EXT 5/16 STL
48	0C3468	1	ENCL-NEM1 1-150A	119	063378	13	HOLDER CABLE TIE
	0C3468A	1	ENCL W/IN-NEM1 1-150A	120	028430	2	NUT HEX #10-24 STEEL
	0C3470	1	ENC W/IN-NEM12 100A CTTS	121	074906	3	SCREW HHTT M6-1.0 X 20 BP
	0C3470A	1	ENCL-NEM12 100A CTTS	122	023897	2	WASHER FLAT #10 ZINC
	0C3471A	1	ENCL W/IN-NEM3R 1-150	123	025870	1	NUT WING 1/4-20
	0C3471	1	ENCL-NEM3R 1-150A	124	0C8275	4	SCREW PPHM DSEMS M4-7 X 10 ZNC
	0C3472A	1	ENC W/IN-NEM4 1-150A	125	092980	1	SCREW PPHM M4-0.7 X 25
	0C3472	1	ENCL-NEM4 1-150A	126	022152	2	WASHER LOCK #10
	0C3472C	1	ENL W/IN-NEM4X 1-150				

Section 7 – Exploded Views & Parts Lists

Generac GTS "Wn" Type Transfer Switch

100A Assembly - Drawing No. 0E7363\$ Part 2

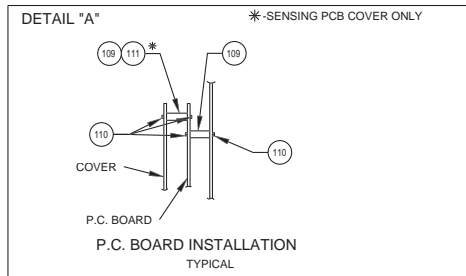
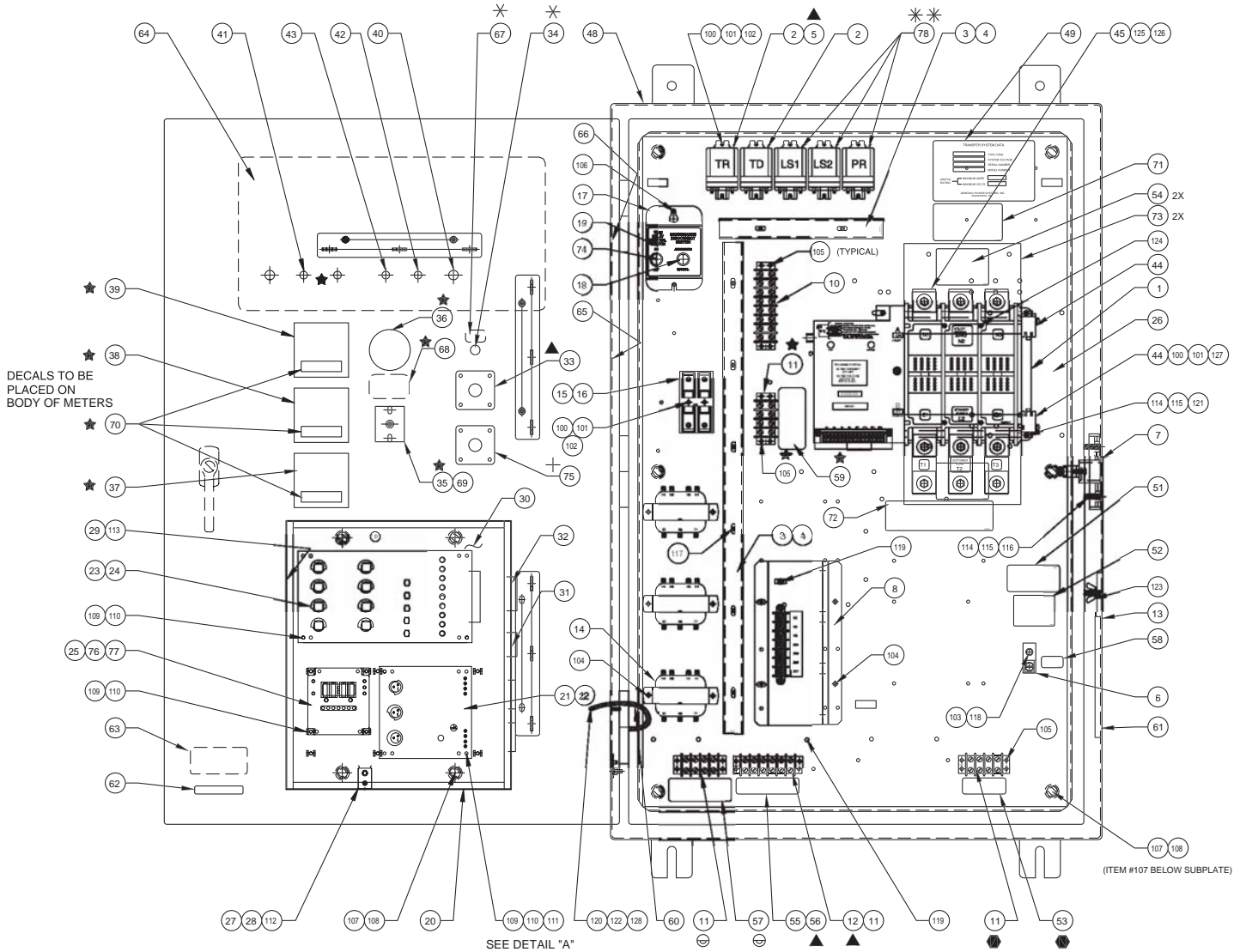

- LEGEND**
- ★ - INSTRUMENT PACKAGE
 - ✱ - RETURN TO NORMAL BYPASS
 - ▲ - PREFERRED SOURCE SELECTOR
(USE 3-POLE RELAY AND 6-POLE TERMINAL STRIP)
 - ⊕ - REMOTE AUTO CONTROL
 - ⊗ - AUTO/NORMAL/STANDBY SELECTOR
 - ✱⊗ - TRIP TO NEUTRAL

Section 7 – Exploded Views & Parts Lists

Generac GTS "Wn" Type Transfer Switch

100A Assembly - Drawing No. 0E7363\$ Part 2

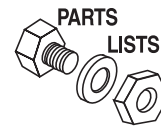

ITEM	PART NO.	QTY.	DESCRIPTION	ITEM	PART NO.	QTY.	DESCRIPTION
1	0E4931	1	XFER SW 200A600V 3P WN TYPE	51	083736	1	DECAL-CSA GTS
	0E7505	1	XFER SW 200A600V 4P WN TYPE	52	062209	1	DECAL UL LABEL E84929-GTS
2	063617	REF	RELAY PNL 12VDC DPDT 10A@240VA	53**	0E5548	1	DECAL LOAD-SHED-PERMISSIVE
3	091472A	REF	COVER WIRE DUCT 1 IN	54	0C8308	2	DECAL TERMINAL SHOCK HAZARD
4	091472	REF	DUCT WIRING 1X1.5 6 FT	55	091466	1	DECAL 2 WR TERM STRP
5▲	057334	REF	RELAY PNL 12VDC 3PDT 10A FL MT	56▲	098876	1	DECAL, DUAL START
6	062684	1	LUG SLDLSS 2/0-#12 X 11/32 CU	57●	074571	1	DECAL-REM. AUTO CNTR
7	0C4449	1	ASSY NEUTRAL BLOCK 100A	58	067210A	1	DECAL GROUND LUG
8	067617030B	1	INTRFC,3PHS 208/240V	59★	064114	1	DECAL-CUST CONN CTS
	086961	1	INTRFC,1PH 240V	60	0536210193	1	GND WIRE-ENCLSR DOOR
	057701	1	BLOCK TERM 20A 8 X 6 X 1100V	61	0D4545	1	DECAL, MANUAL OPERATION
10	046689	REF	BLOCK TERM 20A 4 X 6 X 1100V	62	077228	1	DECAL-ENCLOSURE NOTE
11★**●	046357	REF	BLOCK TERM 20A 6 X 6 X 1100V	63	095282	1	DECAL-LIVE CIRCUIT
12▲	063321	1	HANDLE XFER SWITCH 1-400A	64	0C2864	1	ENC DEC-OEM XFER SW
13	090975	3	XFMR 240/40V 25VA (480V & UNDER)		0C8135	1	DECAL-OEM DR-IN-DR
14	073590C	2	FUSE,BBS 1A 600V		0E5374	1	DECAL-ENCLOSURE PRIVATE LABEL
15	0D2806	1	FUSEBLOCK 30A 600V 2POS W/SQ		0E5371	1	DECAL-DOOR IN DOOR PRIVATE LABEL
16	074509	1	BRACKET SWITCH	65	063385A	1	SWITCH INFO DECAL
17	055868	1	SWITCH TOGGLE 4PDT 15A SPADE	66	073619N	1	DECAL-TEST SEQ150AWN
18	074511	1	DECAL TDN MAINTENANCE SW		073619C	1	DEC-TEST SEQ200AW/WN
19	0C1652	1	ENCLOSURE-PCB, NEW	67*	075369	1	DECAL-RET NML BYPASS
20	067616020A	1	ASSY-STNDSNS CVRPLT	68★	0C2603	1	DECAL PH SELECT A/V
21	067629	1	ASSY STANDARD SENSNG	69★	0E1301	1	AUX CONT INSULATOR__
22	092734	1	ASSY INPHASE MONITOR	70★	0C4895	4	DECAL SHOCK HAZARD
23	094200A	1	ASSY-INPH COVR PLAT	71	054199	1	DECAL HIGH VOLTAGE
24	0A8637	1	ASSY MK3 EXERCISER W/COVER	72	064510	1	DECAL-TERMINAL NOTE
25	064217	1	ASSY 7-DAY EXERCISER (NOT SHOWN)	73	0C7907D	2	COVER LUG 3P 150/200AMP
26	0C3593	1	SBPL100A W/Y/C-XFRSW		0C7907E	2	COVER LUG 4P 150/200AMP
27	063982	1	CLIP BATT-9V TRANSIS	74	028199	1	SWITCH TOGGLE SPST 6A TAB C-H
28	063998	1	BATTERY 9V	75	074614	1	SW 3 POS NRM/ATO/STB
29	0C1720	1	SD GUIDE-NEW PCB ENC	76	0E2651	1	CABLE, DLX-STD INTERFACE (NOT SHOWN)
30	0C1721	1	DOOR, NEW PCB ENC	77	063996	1	ASSY, COVER STANDARD EXERCISER (NOT SHOWN)
31	038057	1	GROMMET 7/8 X 1/16 X 3/4				
32	072252	1	GROMMET 1.37 X .06 X 1.00	78	0E5820	3	RELAY PNL 24VAC DPDT 10A FL MT
33▲	074613	1	SW 2POS SOURCE SELCT	100	038150	REF	WASHER FLAT #8 ZINC
34*	072827	1	SWITCH TOG SPST 6A@125V SP MOM	101	022264	REF	WASHER LOCK #8-M4
35★	061945	1	SWITCH SELECTOR 6A AMP/V	102	0A2284	REF	SCREW SWAGE 8-32 X 1/2 Z/YC
36★	070081	1	HOURMETER	103	024526	1	SCREW HHTT 5/16-18 X 3/4 CZ
37★	070057	1	AMMETER AC 0-300	104	056893	REF	SCREW CRIMPITITE 10-24 X 1/2
38★	070042	1	FREQUENCY METER 240V 55-65HZ	105	0A1661	REF	RIVET POP .156 X .675 AL
39★	070043	1	VOLTMETER AC 0-300	106	0A2111	4	SCREW SWAGE 10-32 X 5/16 Z/YC
40	055142	1	SWITCH TOG DPDT 15A MOM W/SEAL	107	022131	10	WASHER FLAT 3/8-M10 ZINC
41	0C2163C	1	LED YEL WITH HOLDER	108	064101	10	NUT LOCK FL 3/8-16
42	0C2163A	1	LED GRN WITH HOLDER	109	064525	16	STANDOFF HEX 3/4
43	0C2163B	1	LED RED WITH HOLDER	110	064526	40	SCREW S-THR PH #6-25 X 3/8 ZNC
44	074604	REF	AUX CNTCT N-TYP SPDT	111+	068337	4	STANDOFF-HEX 1.00 LG
	074672A	REF	LMT SW-WN SEL&AUX2PL	112	0D7505	2	RIVET POP .094 X .250 BLND AL
45	0A9949	REF	LUG SLDLSS 400-#4X1/4-20 CU7AL	113	036261	4	RIVET POP .125 X .275 AL
46★	064118	REF	TRANSFRM 300A TO 5A 7.5VA (200A ONLY)	114	022473	REF	WASHER FLAT 1/4-M6 ZINC
47	0E7598A	REF	GTS 100-200A TTN WRS-STNDRD (NOT SHOWN)	115	022097	REF	WASHER LOCK M6-1/4
				116	022127	2	NUT HEX 1/4-20 STEEL
48	0C3468	1	ENCL-NEM1 1-150A	117	091477	8	RIVET, WIRE DUCT MNT
	0C3468A	1	ENCL W/IN-NEM1 1-150A	118	027482	1	WASHER SHAKEPROOF EXT 5/16 STL
	0C3470	1	ENC W/IN-NEM12 100A CTTS	119	063378	13	HOLDER CABLE TIE
	0C3470A	1	ENCL-NEM12 100A CTTS	120	028430	2	NUT HEX #10-24 STEEL
	0C3471A	1	ENCL W/IN-NEM3R 1-150	121	074906	3	SCREW HHTT M6-1.0 X 20 BP
	0C3471	1	ENCL-NEM3R 1-150A	122	023897	2	WASHER FLAT #10 ZINC
	0C3472A	1	ENC W/IN-NEM4 1-150A	123	025870	1	NUT WING 1/4-20
	0C3472	1	ENCL-NEM4 1-150A	124	0C8275	4	SCREW PPHM DSEMS M4-7 X 10 ZNC
	0C3472C	1	ENL W/IN-NEM4X 1-150	125	0C4896	REF	SCREW FHM M8-1.25 X 20MM CR
	0C3472B	1	ENCL-NEM4X 1-150A	126	067989	REF	NUT HEX FL WHIZ M8-1.25
49	063578	1	PLATE DATA - OEM	127	092980	1	SCREW PPHM M4-0.7 X 25
	0E5495	1	DECAL DATA PRIVATE LABEL	128	022152	2	WASHER LOCK #10
50	064153A	REF	WIRE-XFMR JUMPER (NOT SHOWN)				



Section 7 – Exploded Views & Parts Lists

Generac GTS “Wn” Type Transfer Switch

200/400A H.V. Assembly - Drawing No. 0E5011

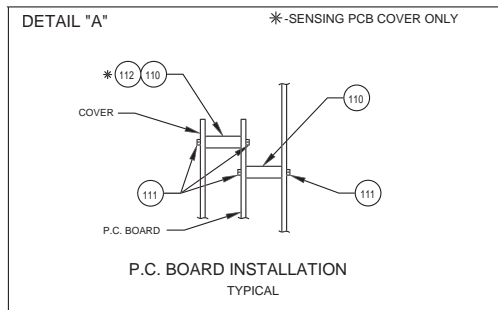
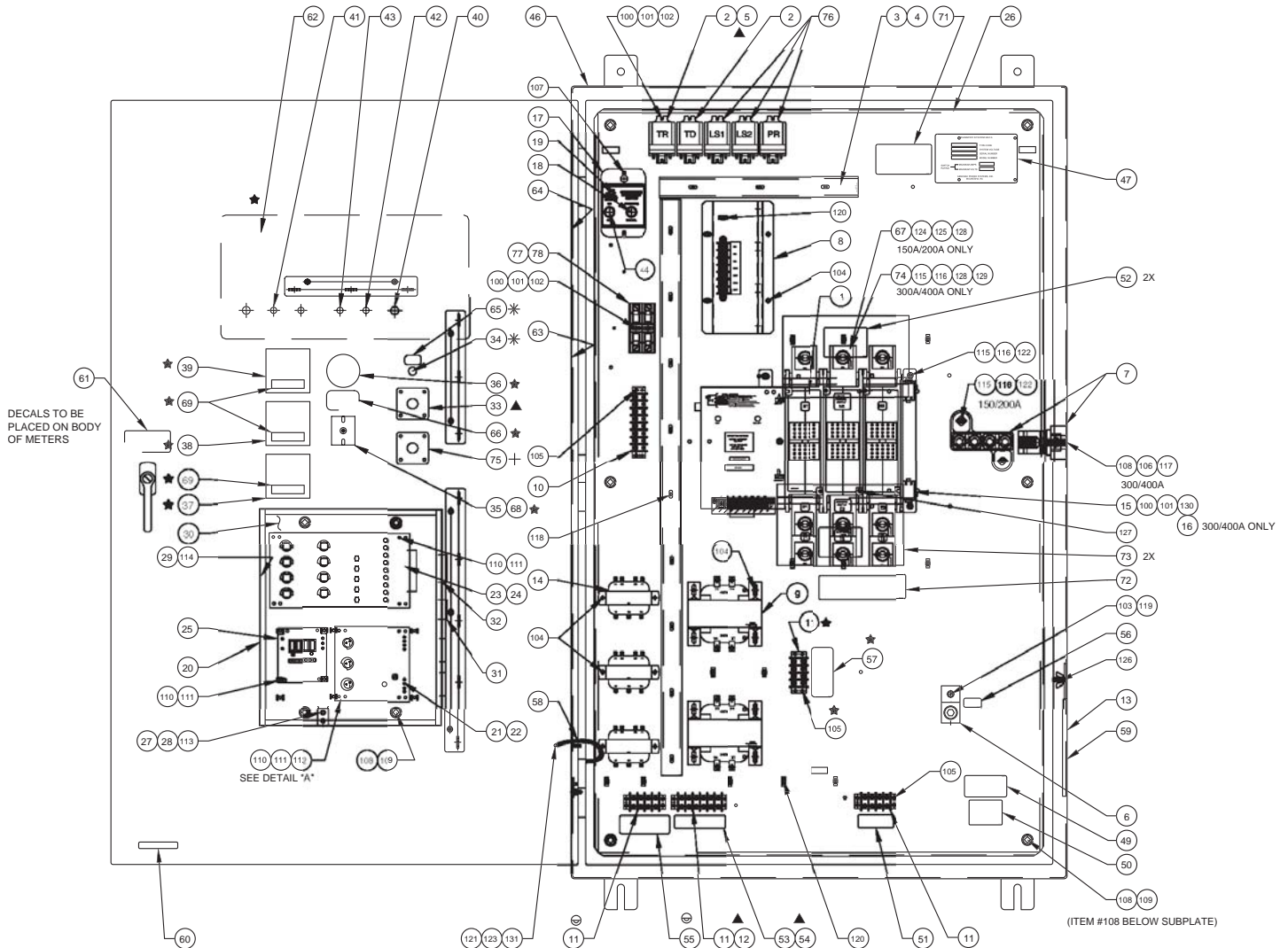

LEGEND

- ★ - INSTRUMENT PACKAGE
- * - RETURN TO NORMAL BYPASS
- ▲ - PREFERRED SOURCE SELECTOR (USE 3-POLE RELAY AND 6-POLE TERMINAL STRIP)
- ⊖ - REMOTE AUTO CONTROL
- + - AUTO/NORMAL/STANDBY
- * * - TRIP TO NEUTRAL

ITEM PART NO. QTY. DESCRIPTION

ITEM	PART NO.	QTY.	DESCRIPTION
1	0E4931	1	XFER SW 200A600V 3P WN TYPE
	0E7505	1	XFER SW 200A600V 4P WN TYPE
	0E4932	1	XFER SW 400A600V 3P WN TYPE
	0E7506	1	XFER SW 400A600V 4P WN-TYPE
2	063617	2	RELAY PNL 12VDC DPDT 10A@240VA
3	091472A	REF	COVER WIRE DUCT 1 IN
4	091472	REF	DUCT WIRING 1X1.5 6 FT
5▲	057334	REF	RELAY PNL 12VDC 3PDT 10A FL MT

ITEM PART NO. QTY. DESCRIPTION

ITEM	PART NO.	QTY.	DESCRIPTION
6	057329	1	LUG SLDLSS 350-#6X13/32 AL/CU
7	0C4449A	1	ASSY NEUTRAL BLOCK 200A
	0C2162	1	ASSY NEUTRAL BLOCK 300-400A
8	072158	1	INTRFC,3PHS 600V
	072160	1	INTRFC,3P 400V 50/60
	067617030A	1	INTRFC,3PHS 416/480V
	067617030B	1	INTRFC,3PHS 208/240V
	086961	1	INTRFC,1PH 240V

Section 7 — Exploded Views & Parts Lists

Generac GTS "Wn" Type Transfer Switch

200/400A H.V. Assembly - Drawing No. 0E5011

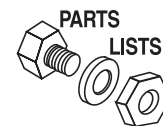

ITEM	PART NO.	QTY.	DESCRIPTION	ITEM	PART NO.	QTY.	DESCRIPTION	
9	072162	2	TRANSFRM 600V TO 240V 200VA	60	077228	1	DECAL-ENCLOSURE NOTE	
	064126	2	TRANSFRM 240/480V-120/240V	61	095282	1	DECAL-LIVE CIRCUIT	
10	057701	1	BLOCK TERM 20A 8 X 6 X 1100V	62	0C2864	1	ENC DEC-OEM XFER SW	
11★**	046689	REF	BLOCK TERM 20A 4 X 6 X 1100V		0C8135	1	DECAL-OEM DR-IN-DR	
12★	046357	REF	BLOCK TERM 20A 6 X 6 X 1100V	63	063385A	1	SWITCH INFO DECAL	
13▲	063321	1	HANDLE XFER SWITCH 1-400A	64	073619N	1	DECAL-TEST SEQ150AWN	
14	090975	3	XFMR 240/40V 25VA		073619C	1	DEC-TEST SEQ200AW/WN	
	095394	3	XFRMR 600/40V 25VA		073619P	1	DECAL-TEST SEQ 300 W	
15	074604	REF	AUX CONTACT N-TYP SPDT		073619R	1	DECAL-TEST SEQ 400 W	
	074672A	REF	LMT SW-WN SEL&AUX2PL		073619J	1	DECAL-TEST SEQ1200WN	
16	092979	1	AUX CONT INSULATOR		073619K	1	DECAL-TEST SEQ1600WN	
17	074509	1	BRACKET SWITCH		073619L	1	DECAL-TEST SEQ2000WN	
18	055868	1	SWITCH TOGGLE 4PDT 15A SPADE	65*	075369	1	DECAL-RET NML BYPASS	
19	074511	1	DECAL-TDN,MAINT. SW.	66★	0C2603	1	DECAL PH SELECT A/V	
20	0C1652	1	ENCLOSURE-PCB	67	0A9949	1	LUG SLDLSS 400-#4X1/4-20 CU7AL	
21	067616020A	1	ASSY-STNDSNS CVRPLT	68★	0E1301	14	COVER PHASE SELECTOR SW	
22	067629	1	ASSY STANDARD SENSNG	69★	0C4895	4	DECAL SHOCK HAZARD	
23	092734	1	ASSY INPHASE MONITOR	70★	064118	REF	TRNFR 300A TO 5A 7.5VA (200A ONLY) (NOT SHOWN)	
24	094200A	1	ASSY-INPH COVER PLATE		★	064119	REF	TRNFR 400A TO 5A 10VA (300A ONLY) (NOT SHOWN)
25	0A8637	1	ASSY MK3 EXERCISER		★	064120	REF	TRNFR 600A TO 5A 15VA (400A ONLY) (NOT SHOWN)
26	0C3938	1	SBPL15-400A W/Y/C-SW	71	054199	1	DECAL HIGH VOLTAGE	
27	063982	1	CLIP BATT-9V TRANSIS	72	064510	1	DECAL-TERMINAL NOTE	
28	063998	1	BATTERY 9V	73	0C7907D	2	COVER LUG 3P 150/200AMP	
29	0C1720	2	SD GUIDE-NEW PCB ENC		0C7907E	2	COVER LUG 4P 150/200AMP	
30	0C1721	1	DOOR, NEW PCB ENC		0C7907F	2	COVER LUG 3P 300/400AMP	
31	038057	1	GROMMET 7/8 X 1/16 X 3/4		0C7907G	2	COVER LUG 4P 300/400AMP	
32	072252	1	GROMMET 1.37 X .06 X 1.00	74	0A7822	REF	LUG SLDLSS 600/250-1/0X1/4-28	
33▲	074613	1	SW 2POS SOURCE SELCT		75	074614	1	SW 3 POS NRM/ATO/STB
34*	072827	1	SWITCH TOG SPST 6A@125V SP MOM	76	0E5820	3	RELAY PNL 24VAC DPDT 10A FL MT	
35★	061945	1	SWITCH SELECTOR 6A AMP/V	77	073590C	2	FUSE,BBS 1A 600V	
36★	070081	1	HOURMETER	78	0D2806	1	FUSEBLOCK 30A 600V 2POS W/SQ	
37★	070057	1	AMMETER AC 0-300 (200A ONLY)	100	038150	REF	WASHER FLAT #8 ZINC	
★	070058	1	AMMETER AC 0-400 (300A ONLY)	101	022264	REF	WASHER LOCK #8-M4	
★	070059	1	AMMETER AC 0-600 (400A ONLY)	102	0A2284	REF	SCREW SWAGE 8-32 X 1/2 Z/YC	
38★	070042	1	FREQUENCY METER 240V 55-65HZ	103	024526	1	SCREW HHTT 5/16-18 X 3/4 CZ	
39★	070043	1	VOLTMETER AC 0-300	104	056893	REF	SCREW CRIMPTITE 10-24 X 1/2	
★	070044	1	VOLTMETER AC 0-600	105	0A1661	REF	RIVET POP .156 X .160-.164#20	
40	055142	1	SWITCH TOG DPDT 15A MOM W/SEAL	106	022237	2	WASHER LOCK 3/8	
41	0C2163C	1	LED YEL WITH HOLDER	107	0A2111	2	SCREW SWAGE 10-32 X 5/16 Z/YC	
42	0C2163A	1	LED GRN WITH HOLDER	108	022131	REF	WASHER FLAT 3/8-M10 ZINC	
43	0C2163B	1	LED RED WITH HOLDER	109	064101	10	NUT LOCK FL 3/8-16	
44	028199	1	SWITCH TOGGLE SPST 6A TAB C-H	110	064525	16	STANDOFF HEX 3/4	
45	0E5342	1	HARNESS (NOT SHOWN)	111	064526	40	SCREW TAP HWH #6-25 X 3/8 ZINC	
46	0C3474	1	ENCL-NEM1 15-400A	112	068337	4	STANDOFF-HEX 1.00 LG	
	0C3474A	1	ENLW/IN-NEM1 15-400A	113	0D7505	2	RIVET POP .094 X .250 BLND AL	
	0C3475	1	ENLW/IN-NEM12 15-400	114	036261	4	RIVET POP .125 X .129-.133#30	
	0C3475A	1	ENCL-NEM12 15-400A	115	022473	REF	WASHER FLAT 1/4 ZINC	
	0C3477A	1	ENLW/IN-NEM3R 15-400	116	022097	REF	WASHER LOCK M6-1/4	
	0C3477	1	ENCL-NEMA,3R,GTS,150-400A	117	022241	2	NUT HEX 3/8-16 STEEL	
	0C3478A	1	ENLW/IN-NEM4 15-400A	118	091477	13	RIVET WIRE DUCT MNT	
	0C3478	1	ENCL-NEM4 15-400A	119	027482	1	WASHER SHAKEPROOF EXT 5/16 STL	
	0C3478C	1	ENLW/IN-NEM4X 15-400	120	063378	15	HOLDER CABLE TIE	
	0C3478B	1	ENCL-NEM4X 15-400A	121	028430	2	NUT HEX #10-24 STEEL	
47	063578	1	PLATE DATA - OEM	122	074906	REF	SCREW HHTT M6-1.0 X 20 BP	
	0E5495	1	PLATE DATA - PRIVATE LABEL	123	023897	2	WASHER FLAT #10 ZINC	
48	064153A	REF	WIRE-XFMR JUMPER (NOT SHOWN)	124	0C4896	REF	SCREW FHM M8-1.25 X 20MM CR	
49	083736	1	DECAL-CSA GTS (OPTIONAL)	125	067989	2	NUT HEX FL WHIZ M8-1.25	
50	062209	1	DECAL UL LABEL E84929-GTS	126	025870	1	NUT WING 1/4-20	
51**	0E5548	1	DECAL LOAD-SHED-PERMISSIVE	127	0C8275	4	SCREW PPHM DSEMS M4-7 X 10 ZNC	
52	0C8308	2	DECAL TERMINAL SHOCK HAZARD	128	026902	7	SCREW HHTT #8-32 X 1/4 CZ	
53	091466	1	DECAL 2 WR TERM STRP	129	0A8261	REF	SCREW HHC 1/4-28 X 5/8 .625TH	
54▲	098876	1	DECAL, DUAL START	130	092980	2	SCREW PPHM M4-0.7 X 25	
55●	074571	1	DECAL-REM. AUTO CNTR	131	022152	2	WASHER LOCK #10	
56	067210A	1	DECAL GROUND LUG					
57★	064114	1	DECAL-CUST CONN GTS					
58	0536210193	1	GND WIRE-ENCLSR DOOR					
59	074525	1	DECAL MANUAL OPERATION					

Section 7 – Exploded Views & Parts Lists

Generac GTS "Wn" Type Transfer Switch

400A L.V. Assembly - Drawing No. 0E7352

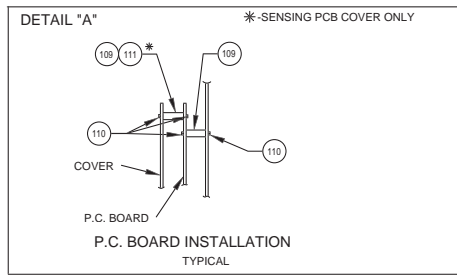
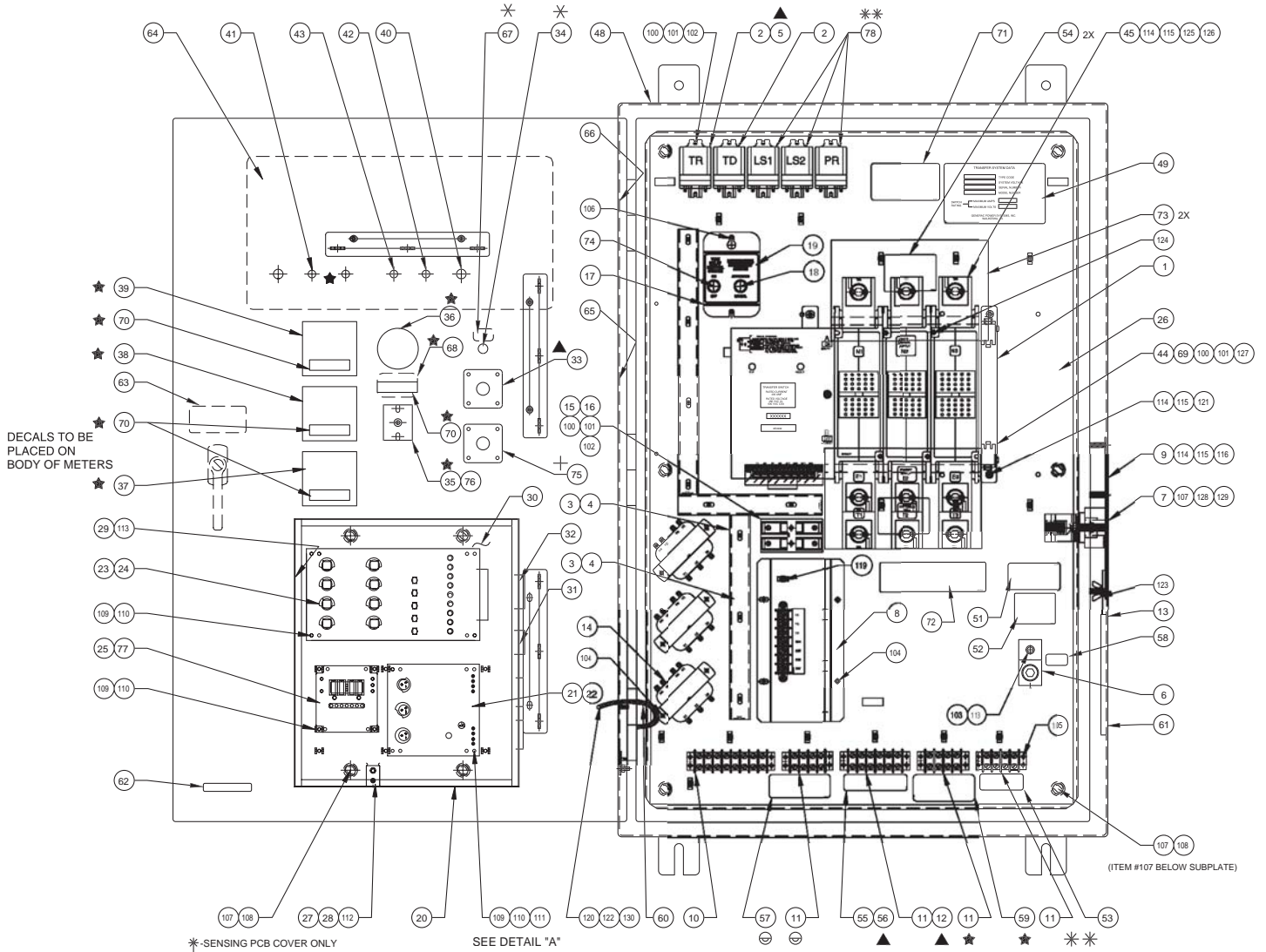

- LEGEND**
- ★ - INSTRUMENT PACKAGE
 - * - RETURN TO NORMAL BYPASS
 - ▲ - PREFERRED SOURCE SELECTOR (USE 3-POLE RELAY AND 6-POLE TERMINAL STRIP)
 - ⊖ - REMOTE AUTO CONTROL
 - ⊕ - AUTO/NORMAL/STANDBY SELECTOR
 - * * - TRIP TO NEUTRAL

Section 7 — Exploded Views & Parts Lists

Generac GTS "Wn" Type Transfer Switch

400A L.V. Assembly - Drawing No. 0E7352

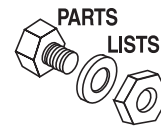

ITEM	PART NO.	QTY.	DESCRIPTION				
				51	083736	1	DECAL-CSA GTS
				52	062209	1	DECAL UL LABEL E84929-GTS
				53*	0E5548	1	DECAL LOAD-SHED-PERMISSIVE
				54	0C8308	2	DECAL TERMINAL SHOCK HAZARD
				55	091466	1	DECAL 2 WR TERM STRP
				56▲	098876	1	DECAL, DUAL START
				57●	074571	1	DECAL-REM. AUTO CNTR
				58	067210A	1	DECAL GROUND LUG
				59★	064114	1	DECAL-CUST CONN CTS
				60	0536210193	1	GND WIRE-ENCLSR DOOR
				61	0D4545	1	DECAL, MANUAL OPERATION
				62	077228	1	DECAL-ENCLOSURE NOTE
				63	095282	1	DECAL-LIVE CIRCUIT
				64	0C2864	1	ENC DEC-OEM XFER SW
					0C8135	1	DECAL-OEM DR-IN-DR
					0C1897	1	DECAL-OEM PWR SYST
					0E5374	1	DECAL-ENCLOSURE PRIVATE LABEL
					0E5371	1	DECAL-DOOR IN DOOR PRIVATE LABEL
					0E5372	1	DECAL- PRIVATE LABEL
				65	063385A	1	SWITCH INFO DECAL
				66	073619P	1	DECAL-TEST SEQ 300 W
					073619R	1	DECAL-TEST SEQ 400 W
				67*	075369	1	DECAL-RET NML BYPASS
				68★	0C2603	1	DECAL PH SELECT A/V
				69	092979	1	AUX CONT INSULATOR
				70★	0C4895	4	DECAL SHOCK HAZARD
				71	054199	1	DECAL HIGH VOLTAGE
				72	064510	1	DECAL-TERMINAL NOTE
				73	0C7907F	2	COVER LUG 3P 300/400AMP
					0C7907G	2	COVER LUG 4P 300/400AMP
				74	028199	1	SWITCH TOGGLE SPST 6A TAB C-H
				75	074614	1	SW 3 POS NRM/ATO/STB
				76	0E1301	14	COVER, PHASE SELECTOR SW
				77	0E2651	1	CABLE, DLX-STD INTERFACE
				78	0E5820	3	RELAY PNL 24VAC DPDT 10A FL MT
				100	038150	REF	WASHER FLAT #8 ZINC
				101	022264	REF	WASHER LOCK #8-M4
				102	0A2284	REF	SCREW SWAGE 8-32 X 1/2 Z/YC
				103	024526	1	SCREW HHTT 5/16-18 X 3/4 CZ
				104	056893	10	SCREW CRIMPTITE 10-24 X 1/2
				105	0A1661	REF	RIVET POP .156 X .675 AL
				106	0A2111	4	SCREW SWAGE 10-32 X 5/16 Z/YC
				107	022131	REF	WASHER FLAT 3/8-M10 ZINC
				108	064101	10	NUT LOCK FL 3/8-16
				109	064525	16	STANDOFF HEX 3/4
				110	064526	40	SCREW S-THR PH #6-25 X 3/8 ZNC
				111+	068337	4	STANDOFF-HEX 1.00 LG
				112	0D7505	2	RIVET POP .094 X .250 BLND AL
				113	036261	4	RIVET POP .125 X .275 AL
				114	022473	REF	WASHER FLAT 1/4-M6 ZINC
				115	022097	REF	WASHER LOCK M6-1/4
				116	022127	2	NUT HEX 1/4-20 STEEL
				117	091477	11	RIVET, WIRE DUCT MNT
				118	027482	1	WASHER SHAKEPROOF EXT 5/16 STL
				119	063378	16	HOLDER CABLE TIE
				120	028430	2	NUT HEX #10-24 STEEL
				121	074906	3	SCREW HHTT M6-1.0 X 20 BP
				122	023897	2	WASHER FLAT #10 ZINC
				123	025870	1	NUT WING 1/4-20
				124	0C8275	4	SCREW PPHM DSEMS M4-7 X 10 ZNC
				125	026902	REF	SCREW HHTT #8-32 X 1/4 CZ
				126	0A8261	REF	SCREW HHC 1/4-28 X 5/8 .625TH
				127	092980	2	SCREW PPHM M4-0.7 X 25
				128	022237	2	WASHER LOCK 3/8
				129	022241	2	NUT HEX 3/8-16 STEEL
				130	022152	2	WASHER LOCK #10
1	0E4932	1	XFER SW 400A600V 3P WN TYPE				
	0E7506	1	XFER SW 400A600V 4P WN-TYPE				
2	063617	REF	RELAY PNL 12VDC DPDT 10A@240VA				
3	091472A	REF	COVER WIRE DUCT 1 IN				
4	091472	REF	DUCT WIRING 1X1.5 6 FT				
5▲	057334	REF	RELAY PNL 12VDC 3PDT 10A FL MT				
6	057329	1	LUG SLDLSS 350-#6X13/32 AL/CU				
7	0C2162	1	ASSY NEUTRAL BLOCK 300-400A				
8	067617030B	1	INTRFC,3PHS 208/240V				
	086961	1	INTRFC,1PH 240V				
9	0E1719	1	PLATE,NEUTRAL BLK MOUNTING				
10	057701	1	BLOCK TERM 20A 8 X 6 X 1100V				
11★**●	046689	REF	BLOCK TERM 20A 4 X 6 X 1100V				
12▲	046357	REF	BLOCK TERM 20A 6 X 6 X 1100V				
13	063321	1	HANDLE XFER SWITCH 1-400A				
14	090975	3	XFMR 240/40V 25VA				
15	073590C	2	FUSE,BBS 1A 600V				
16	0D2806	1	FUSEBLOCK 30A 600V 2POS W/SQ				
17	074509	1	BRACKET SWITCH				
18	055868	1	SWITCH TOGGLE 4PDT 15A SPADE				
19	074511	1	DECAL TDN MAINTENANCE SW				
20	0C1652	1	ENCLOSURE-PCB, NEW				
21	067616020A	1	ASSY-STNDSNS CVRPLT				
22	067629	1	ASSY STANDARD SENSNG				
23	092734	1	ASSY INPHASE MONITOR				
24	094200A	1	ASSY-INPH COVR PLAT				
25	0A8637	1	ASSY MK3 EXERCISER				
	064217	1	ASSY 7-DAY EXERCISER				
26	0E1682	1	SUBPLATE GTS 400A W-SW				
27	063982	1	CLIP BATT-9V TRANSIS				
28	063998	1	BATTERY 9V				
29	0C1720	1	SD GUIDE-NEW PCB ENC				
30	0C1721	1	DOOR, NEW PCB ENC				
31	038057	1	GROMMET 7/8 X 1/16 X 3/4				
32	072252	1	GROMMET 1.37 X .06 X 1.00				
33▲	074613	1	SW 2POS SOURCE SELCT				
34*	072827	1	SWITCH TOG SPST 6A@125V SP MOM				
35★	061945	1	SWITCH SELECTOR 6A AMP/V				
36★	070081	1	HOURMETER				
37★	070058	1	AMMETER AC 0-400 (300A ONLY)				
	070059	1	AMMETER AC 0-600 (400A ONLY)				
38★	070042	1	FREQUENCY METER 240V 55-65HZ				
39★	070043	1	VOLTMETER AC 0-300				
40	055142	1	SWITCH TOG DPDT 15A MOM W/SEAL				
41	0C2163C	1	LED YEL WITH HOLDER				
42	0C2163A	1	LED GRN WITH HOLDER				
43	0C2163B	1	LED RED WITH HOLDER				
44	074604	REF	AUX CNTCT N-TYP SPDT				
	074672A	REF	LMT SW-WN SEL&AUX2PL				
45	0A7822	REF	LUG SLDLSS 600/250-1/0X1/4-28				
46★	064119	REF	TRANSFRM 400A TO 5A 10VA (NOT SHOWN)				
	064120	REF	TRANSFRM 600A TO 5A 15VA (NOT SHOWN)				
47	0E1720A	REF	GTS 400A LV WRS-STNDRD (NOT SHOWN)				
48	0C3468	1	ENCL-NEM1 1-150A				
	0C3468A	1	ENCL W/IN-NEM1 1-150A				
	0C3470	1	ENC W/IN-NEM12 100A CTTS				
	0C3470A	1	ENCL-NEM12 100A CTTS				
	0C3471A	1	ENCL W/IN-NEM3R 1-150				
	0C3471	1	ENCL-NEM3R 1-150A				
	0C3472A	1	ENC W/IN-NEM4 1-150A				
	0C3472	1	ENCL-NEM4 1-150A				
	0C3472C	1	ENL W/IN-NEM4X 1-150				
	0C3472B	1	ENCL-NEM4X 1-150A				
49	063578	1	PLATE DATA - OEM				
	0E5495	1	DECAL DATA PRIVATE LABEL				
50	064153A	REF	WIRE-XFMR JUMPER (NOT SHOWN)				



Section 7 – Exploded Views & Parts Lists

Generac GTS “Wn” Type Transfer Switch

600-1000A Assembly - Drawing No. 0D8774-D

Parts List on pages 60-61

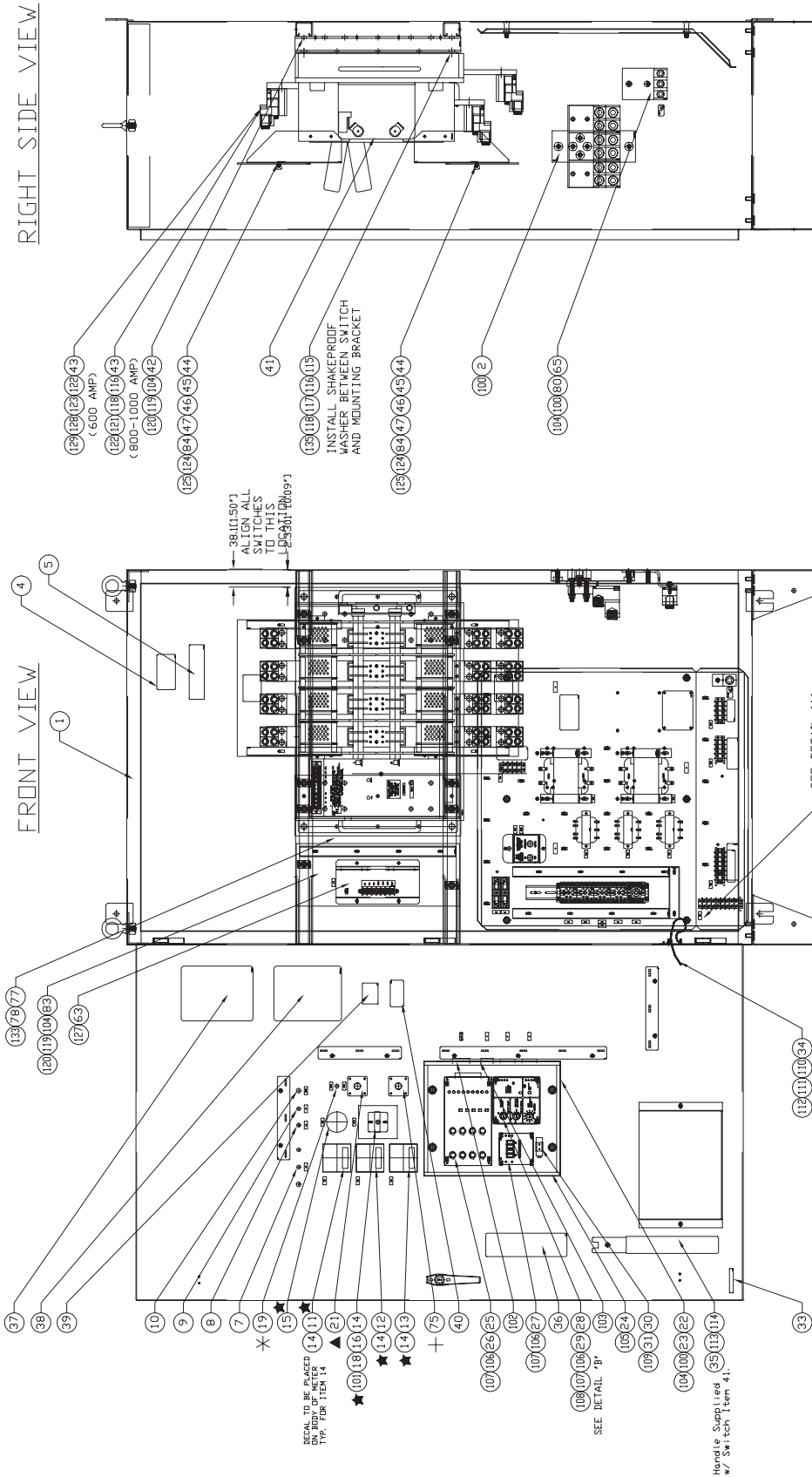

- LEGENDS**
- ★ - INSTRUMENT PACKAGE
 - * - RETURN TO NORMAL BYPASS
 - ▲ - PREFERRED SOURCE SELECTOR (USE 3-POLE RELAY AND 6-POLE TERMINAL STRIP)
 - - REMOTE AUTO CONTROL
 - - SIGNAL BEFORE TRANSFER
 - + - AUTO/NORMAL/STANDBY
 - * - TRIP TO NEUTRAL

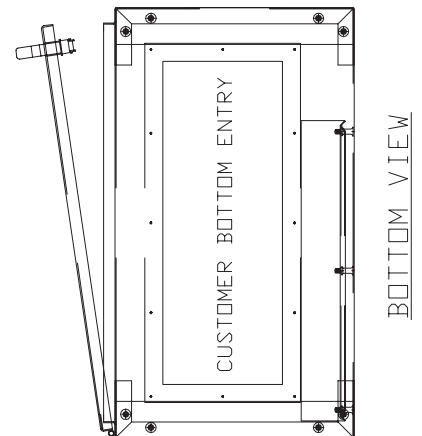
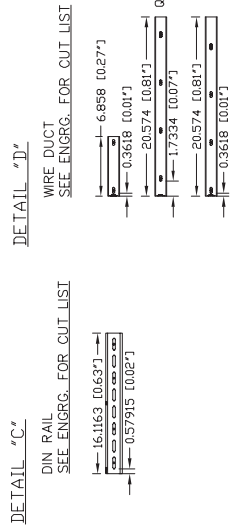

Section 7 – Exploded Views & Parts Lists
Generac GTS "Wn" Type Transfer Switch
600-1000A Assembly - Drawing No. OD8774-D

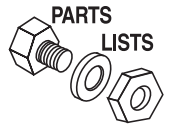

Parts List on pages 60-61

FRONT DOOR VIEW

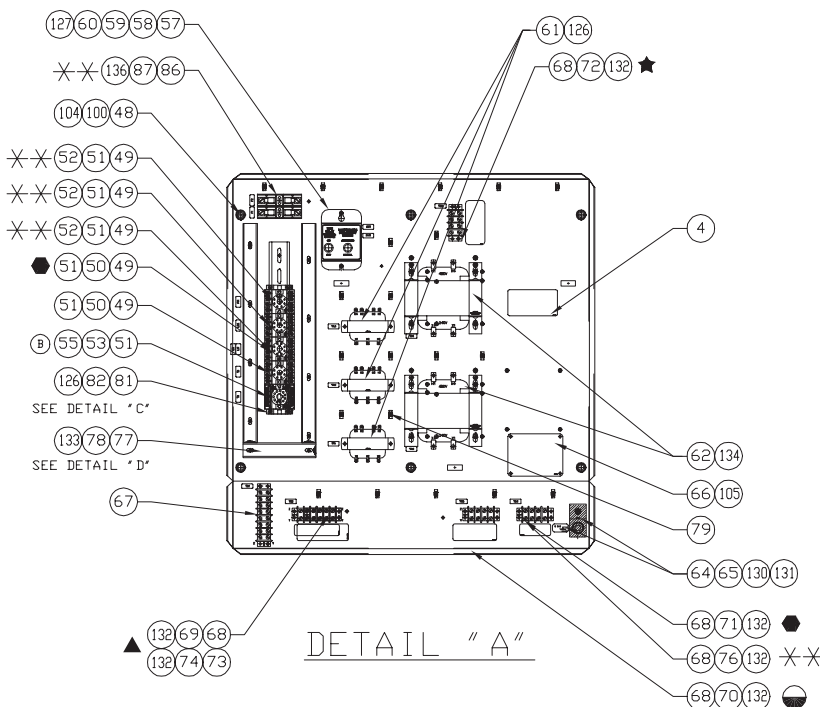
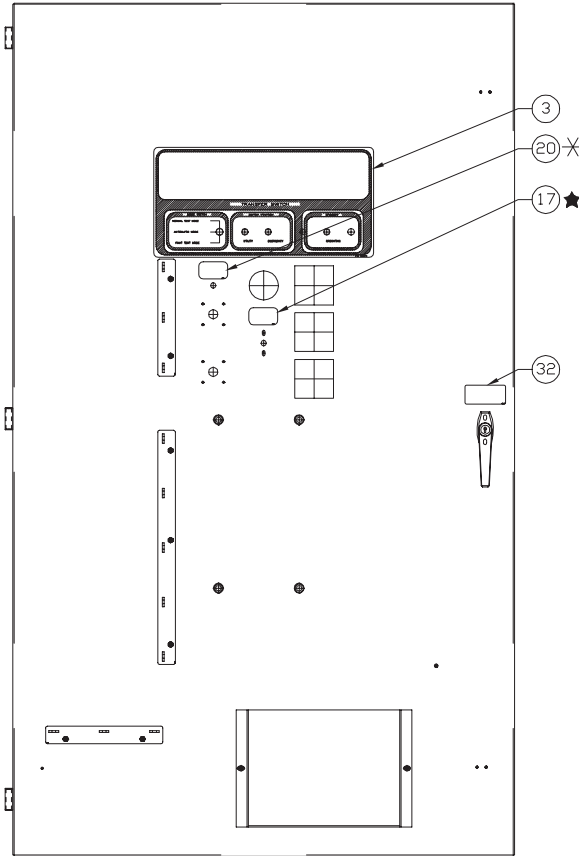

P.C. BOARD INSTALLATION (TYPICAL)

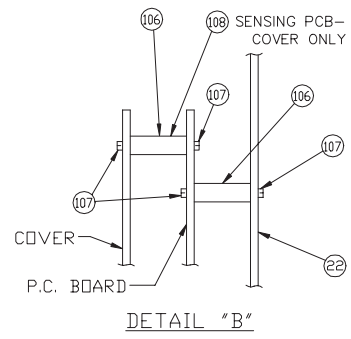

APPLY AN EVEN AMOUNT OF NOALOX (JOINT COMPOUND) ON MASK AREA.



Section 7 – Exploded Views & Parts Lists

Generac GTS “Wn” Type Transfer Switch

600-1000A Assembly - Drawing No. 0D8774-D

ITEM	PART NO.	QTY.	DESCRIPTION	ITEM	PART NO.	QTY.	DESCRIPTION
1	0D8646A	1	ENCL-600-1000A,OPT.NONE	40	083736	1	DECAL-CSA GTS
	0D8646B	1	ENCL-600-1000A,OPT.1	41	072111	1	XFRSW 600A 3P WN600V
	0D8646C	1	ENCL-600-1000A,OPT.2		072117	1	XFRSW 600A 4P WN600V
	0D8646D	1	ENCL-600-1000A,OPT.3		072112	1	XFRSW 800A 3P WN600V
	0D8646E	1	ENCL-600-1000A,OPT.4,5,6,7,8		072118	1	XFRSW 800A 4P WN600V
	0D8646F	1	ENCL-600-1000A,OPT.1,2		072113	1	XFRSW 1000A 3P WN600V
	0D8646G	1	ENCL-600-1000A,OPT.1,3		072119	1	XFRSW 1000A 4P WN600V
	0D8646H	1	ENCL-600-1000A,OPT.1,4,5,6,7,8	42	075099	2	MOUNTING BRACKET-WN
	0D8646J	1	ENCL-600-1000A,OPT.2,3	43	080433	12	LUG SLDLSS 500-#1X13/32 AL/CU
	0D8646K	1	ENCL-600-1000A,OPT.2,4,5,6,7,8		063925	12	LUG SLDLSS 500-4/0X17/32 AL/CU
	0D8646L	1	ENCL-600-1000A,OPT.3,4,5,6,7,8	44	074349A	2	SW CVR WN 600A 3P
	0D9118A	1	ENCL-3R-600-1000A OPT.1,2,3		074349B	2	SW CVR WN 600A 4P
	0D9118B	1	ENCL-3R-600-1000A OPT.1-8		074349C	2	SW CVR WN 800/1000A 3P
2	0D8700	1	ASSY NEUTRAL BLK 600-1000A ATS		074349D	2	SW CVR WN 800/1000A 4P
	0D4203	1	NEUTRAL BLOCK ASS'Y 1600A ATS	45	063986	4	KNOB,COVER HOLD-DOWN
3	0E5374	1	DECAL PRIVATE LABEL ENCLOSURE	46	074351	2	CVR BRCKT 600-1600A
	0C2864	1	ENC DEC-GEN XFER SW OEM	47	074351A	2	CVR BRCKT 600-1600 LH
4	054199	2	ENC DEC-GEN XFER SW	48	0D3110	1	SUBPLT CTTS 600-2600A
5	064510	1	DECAL-TERMINAL NOTE	49	0C3211G	4	SOCKET RELAY 8 PIN
7	0C2163C	1	LED YEL WITH HOLDER	50●	0C3211E	REF	RELAY PNL 12VDC DPDT 8PIN
8	0C2163B	1	LED RED WITH HOLDER	51●	0C3211H	REF	SPRING RELAY RETAINING
9	0C2163A	1	LED GRN WITH HOLDER	52*★	0C3211R	3	RELAY DPDT 24VAC 10A 8PIN
10	055142	1	SWITCH TOG DPDT 15A MOM W/SEAL	53	0C3211L	1	SOCKET RELAY 11 PIN
11★	070043	1	VOLTMETER AC 0-300	55	0C3211K	1	RELAY 12VDC 3PDT
★	070044	1	VOLTMETER AC 0-600	57	074509	1	BRACKET SWITCH
12★	070042	1	FREQUENCY METER 240V 55-65HZ	58	074511	1	DECAL-TDN,MAINT. SW.
13★	070060	1	AMMETER AC 0-800	59	055868	1	SWITCH TOGGLE 4PDT 15A SPADE
★	075323	1	AMMETER AC 0-1000	60	028199	1	SWITCH TOGGLE SPST 6A TAB C-H
★	075324	1	AMMETER AC 0-1600	61	090975	3	XFMR 240/40V 25VA
14★	0C4895	4	DECAL SHOCK HAZARD		095394	3	XFRMR 600/40V 25VA
15★	070081	1	HOURMETER	62	074652	2	TRANSFRM 600V TO 240V 250VA
16★	061945	1	SWITCH SELECTOR 6A AMP/V		064932	2	TRANSFRM 480/240V 250VA
17	0C2603	1	DECAL PH SELECT A/V	63	067617030A	1	INTRFC,3PHS 416/480V
18★	0C2060	1	COVER-PHASE SEL.SW.		067617030B	1	INTRFC,3PHS 208/240V
19*	072827	1	SWITCH TOG SPST 6A@125V SP MOM		072158	1	INTRFC,3PHS 600V
20*	075369	1	DECAL-RET NML BYPASS		072160	1	INTRFC,3P 400V 50/60
21▲	074613	1	SW 2POS SOURCE SELCT		086961	1	INTRFC,1PH 240V
22	0C1652	1	ENCLOSURE-PCB, NEW	64	057329	1	LUG SLDLSS 350-#6X13/32 AL/CU
23	0C1721	1	DOOR, NEW PCB ENC	65	067210A	2	DECAL GROUND LUG
24	0C1720	2	SD GUIDE-NEW PCB ENC	66	063578	1	PLATE DATA - OEM
25	092734	1	ASSY INPHASE MONITOR		0E5495	1	PLATE DATA - PRIVATE LABEL
26	094200A	1	ASSY-INPH COVR PLAT	67	057701	1	BLOCK TERM 20A 8 X 6 X 1100V
27	0A8637	1	ASSY MK3 EXERCISER	68★☉	046689	REF	BLOCK TERM 20A 4 X 6 X 1100V
28	067616020A	1	ASS'Y-STNDSNS CVRPLT	69	091466	1	DECAL 2 WR TERM STRP
29	067629	1	ASSY STANDARD SENSNG	70☉	074571	1	DECAL-REM. AUTO CNTR
30	063982	1	CLIP BATT-9V TRANSIS	71●	075355	1	DECAL-SGNL BFR XFER
31	063998	1	BATTERY 9V	72★	064114	1	DECAL-CUST CONN CTS
32	095282	1	DECAL-LIVE CIRCUIT	73▲	046357	1	BLOCK TERM 20A 6 X 6 X 1100V
33	077228	1	DECAL-ENCLOSURE NOTE	74▲	098876	1	DECAL, DUAL START
34	0536210193	1	GND WIRE-ENCLSR DOOR	75+	074614	1	SW 3 POS NRM/ATO/STB
35	072164	1	MNL HNDL 6-1600A WN	76*★	0E5548	1	DECAL, LOAD SHED
36	074525	1	DECAL-MAN OPERATION	77	091472	REF	DUCT WIRING 1X1.5 6 FT
37	063385A	1	SWITCH INFO DECAL	78	091472A	REF	COVER WIRE DUCT 1 IN
38	073619F	1	DECAL-TEST SEQ 600WN	79	063378	21	HOLDER CABLE TIE
	073619G	1	DECAL-TEST SEQ 800WN	80	0D6584	1	ASSY DWG GRD.TERM.1600-2600A
	073619H	1	DECAL-TEST SEQ1000WN	81	0A9992B	2	BRKT, DIN TERM END
39	062209	1	DECAL UL LABEL E84929-GTS	82	0C3996	REF	RAIL DIN ALUMINUM BULK

Section 7 – Exploded Views & Parts Lists

Generac GTS "Wn" Type Transfer Switch

600-1000A Assembly - Drawing No. 0D8774-D

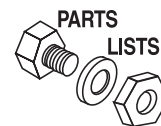

ITEM	PART NO.	QTY.	DESCRIPTION
83	0D8693	1	SUBPLATE, INTERFACE
84	0C8308	2	DECAL TERMINAL SHOCK HAZARD
85	064153A	REF	WIRE-XFMR JUMPER
86**	073590C	2	FUSE,BBS 1A 600V
87**	0D2806	2	FUSEBLOCK 30A 600V 2POS W/SQ
100	064101	14	NUT LOCK FL 3/8-16
101★	0C4979	2	SCREW TAP HWH #8-25 X 3/8 ZINC
102	072252	1	GROMMET 1.37 X .06 X 1.00
103	038057	1	GROMMET 7/8 X 1/16 X 3/4
104	022131	22	WASHER FLAT 3/8-M10 ZINC
105	036261	8	RIVET POP .125 X .129-.133/#30
106	064525	16	STANDOFF HEX ¼
107	064526	40	SCREW TAP HWH #6-25 X 3/8 ZINC
108	068337	4	STANDOFF-HEX 1.00 LG
109	029357	2	RIVET AVDEL3/32X1/8L
110	038150	2	WASHER FLAT #8 ZINC
111	022264	2	WASHER LOCK #8-M4
112	022471	2	NUT HEX #8-32 STEEL
113	022473	1	WASHER FLAT 1/4-M6 ZINC
114	025870	1	NUT WING 1/4-20
115	022304	4	WASHER FLAT 1/2 ZINC
116	022195	REF	WASHER LOCK ½
117	061342	4	SCREW HHC 1/2-13 X 1-1/4 G5
118	022196	REF	NUT HEX 1/2-13 STEEL
119	022237	10	WASHER LOCK 3/8
120	022511	10	SCREW HHC 3/8-16 X 1-1/4 G5
121	023316	REF	SCREW HHC 1/2-13 X 4 G5
122	026902	7	SCREW HHTT #8-32 X 1/4 CZ
123	022302	REF	WASHER LOCK 7/16
124	022152	8	WASHER LOCK #10
125	024469	8	SCREW HHTT #10-32 X 3/8 CZ
126	045764	10	SCREW HHTT M4-0.7 X 8 BP
127	0C2267	14	SCREW HHTT M5-0.8 X 12 BP
128	026209	REF	SCREW HHC 7/16-14 X 1-3/4 G5
129	022509	REF	NUT HEX 7/16-14 STEEL
130	022129	1	WASHER LOCK M8-5/16
131	083512	1	SCREW HHTT M8-1.2 X 16 YC
132	0A1661	REF	RIVET POP .156 X .160-.164/#20
133	091477	11	RIVET, WIRE DUCT MNT
134	090388	8	SCREW HHTT M6-1.0 X 12 YC
135	0D1557	4	WASHER SHAKEPROOF EXT 1/2 STL
136	0C2265	2	SCREW PHTT M4-0.7 X 12 ZYC



Section 7 – Exploded Views & Parts Lists

Generac GTS “Wn” Type Transfer Switch

1200-1600A - Drawing No. 0D9442-D

ITEM	PART NO.	QTY.	DESCRIPTION	ITEM	PART NO.	QTY.	DESCRIPTION
1	SEE TABLE**	1	ENCLOSURE-NEMA GTS 1200-1600A	52**	0C3211R	3	RELAY DPDT 24VAC 10A 8PIN
2	0D4203	1	NEUTRAL BLOCK ASS'Y 1600A ATS	53	0C3211L	1	SOCKET RELAY 11 PIN
3	0E5374	1	DECAL PRIVATE LABEL ENCLOSURE	55	0C3211K	1	RELAY 12VDC 3PDT
	0C2864	1	ENC DEC-OEM XFER SW	57	074509	1	BRACKET SWITCH
4	054199	2	DECAL HIGH VOLTAGE	58	074511	1	DECAL TDN MAINTENANCE SW
5	064510	1	DECAL-TERMINAL NOTE	59	055868	1	SWITCH TOGGLE 4PDT 15A SPADE
7	0C2163C	1	LED YEL WITH HOLDER	60	028199	1	SWITCH TOGGLE SPST 6A TAB C-H
8	0C2163B	1	LED RED WITH HOLDER	61	090975	3	XFMR 240/40V 25VA
9	0C2163A	1	LED GRN WITH HOLDER		095394	3	XFRMR 600/40V 25VA
10	055142	1	SWITCH TOG DPDT 15A MOM W/SEAL	62	074653	2	TRANSFRM 600V TO 240V 350VA
11★	070043	1	VOLTMETER AC 0-300		064929	2	TRANSFRM 240/480V-120/480V
★	070044	1	VOLTMETER AC 0-600	63	067617030A	1	INTRFC,3PHS 416/480V
12★	070042	1	FREQUENCY METER 240V 55-65HZ		067617030B	1	INTRFC,3PHS 208/240V
13★	075325	1	AMMETER AC 0-2000		072158	1	INTRFC,3PHS 600V
14★	0C4895	4	DECAL SHOCK HAZARD		072160	1	INTRFC,3P 400V 50/60
15★	070081	1	HOURMETER		086961	1	INTRFC,1PH 240V
16★	061945	1	SWITCH SELECTOR 6A AMP/V	64	057329	1	LUG SLDLSS 350-#6X13/32 AL/CU
17	0C2603	1	DECAL PH SELECT A/V	65	067210A	2	DECAL GROUND LUG
18★	0E1301	14	COVER, PHASE SELECTOR SW	66	063578	1	PLATE DATA - OEM
19*	072827	1	SWITCH TOG SPST 6A@125V SP MOM		0E5495	1	PLATE DATA - PRIVATE LABEL
20*	075369	1	DECAL-RET NML BYPASS	67	057701	1	BLOCK TERM 20A 8 X 6 X 1100V
21▲	074613	1	SW 2POS SOURCE SELCT	68★●	046689	4	BLOCK TERM 20A 4 X 6 X 1100V
22	0C1652	1	ENCLOSURE-PCB, NEW	69	091466	1	DECAL 2 WR TERM STRP
23	0C1721	1	DOOR, NEW PCB ENC	70●	074571	1	DECAL-REM. AUTO CNTR
24	0C1720	2	SD GUIDE-NEW PCB ENC	71●	075355	1	DECAL-SGNL BFR XFER
25	092734	1	ASSY INPHASE MONITOR	72★	064114	1	DECAL-CUST CONN CTS
26	094200A	1	ASSY-INPH COVR PLAT	73▲	046357	1	BLOCK TERM 20A 6 X 6 X 1100V
27	0A8637	1	ASSY MK3 EXERCISER	74▲	098876	1	DECAL, DUAL START
28	067616020A	1	ASS'Y-STNDSNS CVRPLT	75	074614	1	SW 3 POS NRM/ATO/STB
29	067629	1	ASSY STANDARD SENSNG	76**	0E5548	1	DECAL, LOAD SHED
30	063982	1	CLIP BATT-9V TRANSIS	77	091472	REF	DUCT WIRING 1X1.5 6 FT
31	063998	1	BATTERY 9V	78	091472A	REF	COVER WIRE DUCT 1 IN
32	095282	1	DECAL-LIVE CIRCUIT	79	063378	21	HOLDER CABLE TIE
33	077228	1	DECAL-ENCLOSURE NOTE	80	0D6584	1	ASSY GRD.TERM.1600-2600A
34	0536210193	1	GND WIRE-ENCLSR DOOR	81	0A9992B	2	BRKT, DIN TERM END
35	072164	1	MNL HNDL 6-1600A WN	82	0C3996	REF	RAIL DIN ALUMINUM BULK
36	074525	1	DECAL MANUAL OPERATION	83	0C8308	2	DECAL TERMINAL SHOCK HAZARD
37	063385A	1	SWITCH INFO DECAL	84	064153A	REF	WIRE-XFMR JUMPER (NOT SHOWN)
38	073619I	1	DECAL-TEST SEQ1200WN	85**	073590C	2	FUSE,BBS 1A 600V
	073619K	1	DECAL-TEST SEQ1600WN	86**	0D2806	2	FUSEBLOCK 30A 600V 2POS W/SQ
39	062209	1	DECAL UL LABEL E84929-GTS	100	064101	14	NUT LOCK FL 3/8-16
40	083736	1	DECAL-CSA GTS (OPT) (NOT SHOWN)	102	072252	1	GROMMET 1.37 X .06 X 1.00
41	072124	1	XFRSW1200A 3P WN600V	103	038057	1	GROMMET 7/8 X 1/16 X 3/4
	072125	1	XFRSW1200A 4P WN600V	104	022131	20	WASHER FLAT 3/8-M10 ZINC
	072114	1	XFRSW1600A 3P WN600V	105+	036261	8	RIVET POP .125 X .275 AL
	072120	1	XFR SW 1600A 4P WN600V	106	064525	16	STANDOFF HEX 3/4
42	075099	2	MOUNTING BRACKET-WN	107	064526	40	SCREW S-THR PH #6-25 X 3/8 ZNC
43	063963	REF	LUG SLDLSS 750-1/2X13/32 AL/CU	108	068337	4	STANDOFF-HEX 1.00 LG
44	074349E	2	SW CVR 1200/1600A 3P	109	029357	2	RIVET AVDEL3/32X1/8L
	074349F	2	SW CVR 1200/1600A 4P	110	038150	2	WASHER FLAT #8 ZINC
45	063986	4	KNOB,COVER HOLD-DOWN	111	022264	2	WASHER LOCK #8-M4
46	074351	2	CVR BRCKT 600-1600A	112	022471	2	NUT HEX #8-32 STEEL
47	074351A	2	CVR BRCKT600-1600 LH	113	022473	1	WASHER FLAT 1/4-M6 ZINC
48	0D3110	1	SUBPLT CTTS 600-2600A	114	025870	1	NUT WING 1/4-20
49	0C3211G	4	SOCKET RELAY 8 PIN	115	022304	4	WASHER FLAT 1/2 ZINC
50●	0C3211E	2	RELAY PNL 12VDC DPDT 8PIN	116	022195	4	WASHER LOCK 1/2
51●	0C3211H	4	SPRING RELAY RETAINING	117	061342	4	SCREW HHC 1/2-13 X 1-1/4 G5

Section 7 – Exploded Views & Parts Lists

Generac GTS "Wn" Type Transfer Switch

1200-1600A - Drawing No. 0D9442-D

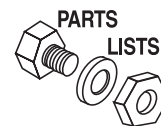

<u>ITEM</u>	<u>PART NO.</u>	<u>QTY.</u>	<u>DESCRIPTION</u>
118	022196	4	NUT HEX 1/2-13 STEEL
119	022237	REF	WASHER LOCK 3/8
120	022511	8	SCREW HHC 3/8-16 X 1-1/4 G5
121	022241	REF	NUT HEX 3/8-16 STEEL
122	022258	REF	SCREW HHC 3/8-16 X 2 G5
123	026902	7	SCREW HHTT #8-32 X 1/4 CZ
124	022152	8	WASHER LOCK #10
125	024469	8	SCREW HHTT #10-32 X 3/8 CZ
126	045764	10	SCREW HHTT M4-0.7 X 8 BP
127	0C2267	22	SCREW HHTT M5-0.8 X 12 BP
	090388	8	SCREW HHTT M6-1.0 X 12 ZINC
128	0D1557	4	WASHER SHAKEPROOF EXT 1/2 STL
130	022129	1	WASHER LOCK M8-5/16
131	083512	1	SCREW HHTT M8-1.2 X 16 YC
132	0A1661	REF	RIVET POP .156 X .675 AL
133	091477	11	RIVET, WIRE DUCT MNT
134**	0C2265	2	SCREW PHTT M4-0.7 X 12 ZYC



Section 8 – Warranty

Generac GTS “Wn” Type Transfer Switch

GENERAC POWER SYSTEMS STANDARD TWO-YEAR LIMITED WARRANTY FOR GENERAC TRANSFER SWITCH SYSTEMS

NOTE: ALL UNITS MUST HAVE A START-UP INSPECTION PERFORMED BY AN AUTHORIZED GENERAC DEALER.

For a period of 2 (two) years from the date of sale/start date, Generac Power Systems, Inc. will, at its option, repair or replace any part(s) which, upon examination, inspection, and testing by Generac Power Systems or a Generac Power Systems Authorized Warranty Service Facility, is found to be defective under normal use and service, in accordance with the warranty schedule set forth below. Any equipment that the purchaser/owner claims to be defective must be returned to, and examined by the nearest Generac Power Systems Authorized Warranty Service Facility. All transportation costs under the warranty, including return to the factory, are to be borne and prepaid by the purchaser/owner. This warranty applies only to Generac Power Systems Transfer Switch applications, as Generac Power Systems, Inc. have defined Transfer Switch application, provided said Transfer Switch has been initially installed and inspected on-site by a Generac Power Systems Authorized Service Dealer or branch thereof. A scheduled maintenance agreement with a local Authorized Generac Power Systems Dealer is highly recommended to verify adequate service has been performed on the unit throughout the warranty period.

WARRANTY SCHEDULE

- **YEAR ONE** — 100% (one hundred percent) coverage on mileage*, labor, and parts listed.
- **ALL COMPONENTS**
- **YEAR TWO** — 100% (one hundred percent) coverage on parts listed.
- **ALL COMPONENTS — *PARTS ONLY**
- *Travel allowance is limited to 300 miles maximum, or 7.5 hours maximum (per occurrence), **round trip**, to the nearest authorized Generac Service Facility.
- A Generac Power Systems, Inc. Transfer Switch is highly recommended to be used in conjunction with the genset. If a non Generac genset is substituted for use and directly causes damage to the Generac Transfer Switch, no warranty coverage shall apply.
- All warranty expense allowances **are** subject to the conditions defined in Generac Power Systems Warranty, Policies, and Procedures Flat Rate Manual.
- Units that have been resold **are not** covered under the Generac Power Systems Warranty, as this Warranty **is not** transferable.

THIS WARRANTY SHALL NOT APPLY TO THE FOLLOWING:

1. Any unit built/manufactured prior to January 1, 2002.
2. Unit enclosure is only covered against rust or corrosion the first year of the warranty provision.
3. Costs of normal maintenance i.e. tune-ups, associated part(s), adjustments, loose/leaking clamps, installation and start-up.
4. Use of Non-Generac replacement part(s) will void the warranty in its entirety.
5. Any failure caused by contaminated fuels, oils, coolants/antifreeze or lack of proper fuels, oils or coolants/antifreeze.
6. Failures due, but not limited to, normal wear and tear, accident, misuse, abuse, negligence, or improper installation or sizing.
7. Failures caused by any external cause or act of God such as collision, fire, theft, freezing, vandalism, riot or wars, lightning, earthquake, windstorm, hail, volcanic eruption, water or flood, tornado, hurricane, terrorist acts or nuclear holocaust.
8. Products that are modified or altered in a manner not authorized by Generac Power Systems in writing.
9. Any incidental, consequential or indirect damages caused by defects in materials or workmanship, or any delay in repair or replacement of the defective part(s).
10. Failure due to misapplication, misrepresentation, or bi-fuel conversion.
11. Telephone, telegraph, teletype or other communication expenses.
12. Living or travel expenses of person(s) performing service, except as specifically included within the terms of a specific unit warranty period.
13. Rental equipment used while warranty repairs are being performed i.e. rental generators, cranes, etc..
14. Overtime labor or more than one person performing repairs.
15. Any and all expenses incurred investigating performance complaints unless defective Generac materials and or workmanship were the direct cause of the problem.
16. *Engine coolant heaters (block-heaters), heater controls and circulating pumps after the first year.
17. *Starting batteries, fuses, light bulbs, engine fluids, tires, brakes, and overnight freight cost for replacement part(s).

THIS WARRANTY IS IN PLACE OF ALL OTHER WARRANTIES, EXPRESSED OR IMPLIED, SPECIFICALLY, GENERAC POWER SYSTEMS MAKES NO OTHER WARRANTIES AS TO THE MERCHANTABILITY OR FITNESS FOR A PARTICULAR PURPOSE. Some states do not allow limitations on how long an implied warranty lasts, so the above limitation may not apply to you.

GENERAC POWER SYSTEMS ONLY LIABILITY SHALL BE THE REPAIR OR REPLACEMENT OF PART(S) AS STATED ABOVE. IN NO EVENT SHALL GENERAC POWER SYSTEMS BE LIABLE FOR ANY INCIDENTAL, OR CONSEQUENTIAL DAMAGES, EVEN IF SUCH DAMAGES ARE A DIRECT RESULT OF GENERAC POWER SYSTEMS, INC. NEGLIGENCE.

Some states do not allow the exclusion or limitation of incidental or consequential damages, so the above limitations may not apply to you. Purchaser/owner agrees to make no claims against Generac Power Systems, Inc. based on negligence. This warranty gives you specific legal rights. You also may have other rights that vary from state to state.

GENERAC® POWER SYSTEMS, INC. · P.O. BOX 8 · WAUKESHA, WI 53187

PH: (262) 544-4811 · FAX: (262) 544-4851

Bulletin 0166260SBY / Printed in USA 5.02